





IV 1026



Digitized by the Internet Archive  
in 2016

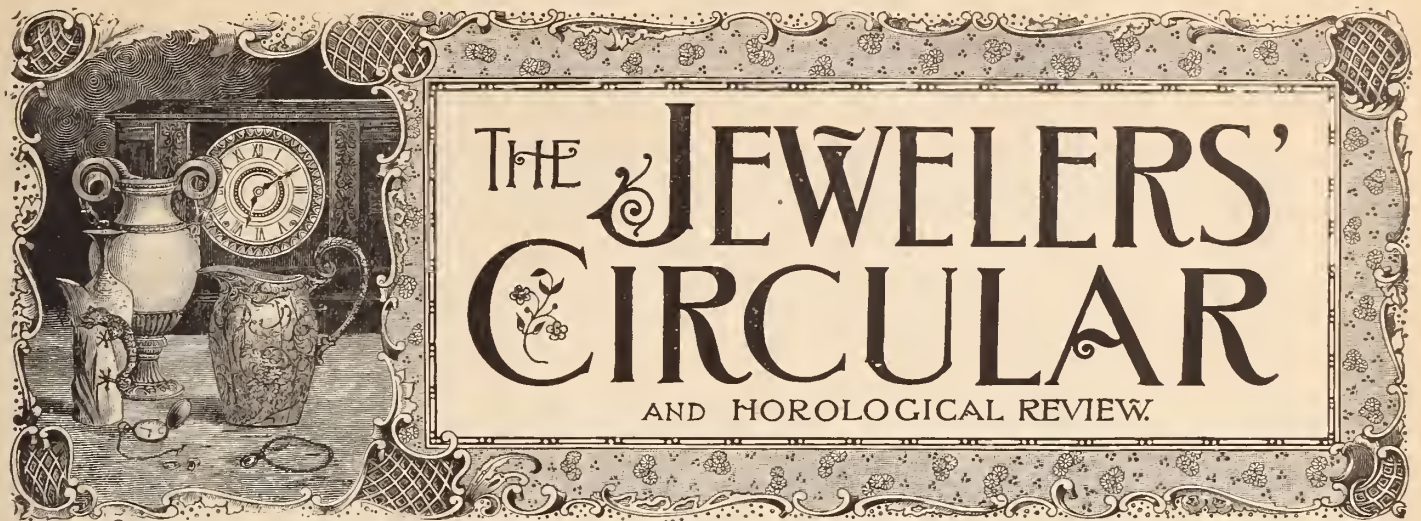

Copyright by THE JEWELERS' CIRCULAR PUB. CO.

189 Broadway, New York.

Entered at the Post Office in N. Y. as second-class matter.

VOL. XXIX.

NEW YORK, WEDNESDAY, OCT. 31, 1894.

No. 14.

### EMBLEMIZING IN SILVER A FASHIONABLE GAME.

THERE have just been delivered by Tiffany & Co., New York, two handsome solid silver challenge cups which were competed for at the Fall tournament of the Morris County Golf Club, beginning Oct. 17th and continuing throughout the week at the Club's grounds, Morristown, N. J. The prizes are both in the form of two handled loving cups,—one a prize for

against two men. The etching upon both trophies is a successful piece of work, as the players are not only full of action, but their positions are lifelike and very graceful. The ladies' cup is differently formed from the other, the body being larger and rounded off at the bottom in a fluted design. It weighs almost 27 ounces, stands 7½ inches high, and measures 5¼ inches across the

first trophies produced in America typifying the game of golf, which is now an overwhelming fad in certain circles of society.

At Leeds, England, is an electric clock which has been continually ticking off the time since 1840. It is without either



TIFFANY & CO. MAKERS

THE MORRIS COUNTY GOLF CLUB CHALLENGE CUPS.

ladies, the other for men. The ladies' cup is the gift of the club's president, Miss Nina Howland; and the one for the men was presented by the vice-president, Mrs. H. McK. Twombly.

Upon the front of each cup is a well executed etching of a field scene, picturing the players in the spirit of the game, the former with two women and one man in the field, and the latter with the order reversed, showing one woman contesting for the ball

top. The gentlemen's cup is of a different form, with a wider opening at the top. The bowl part rests upon a round silver base or foot, and in its entirety, there are suggestions of the rococo, the Louis Quinze, and the Roman periods of decoration. The cup weighs about twenty-six ounces, stands 7¾ inches high, and has a capacity of three pints.

The cups are mainly interesting to jewelers and silversmiths as being among the

springs or weights and has only three wheels. It was made by James Smith, an optician and a relative of the present owner, Edward Smith, jeweler. The motive power is "natural electricity," neither cell nor battery being used. It is kept going by a brass cylinder, containing 2½ miles of fine coiled copper wire, the whole being attached to the lower end of the pendulum, which moves back and forth over a magnetized steel bar.



★ **ROGERS & BRO. A1.**

**CAUTION!**

The name of "ROGERS" is stamped on all sorts of flatware, some of it common, worthless trash. If you keep the STAR brand you sell goods that will satisfy your customers and help build up your reputation as a reliable dealer.

The STAR brand is made by

**Rogers & Brother,**

...OF...

**Waterbury, Conn.**

**16 Cortlandt St., New York.**

The oldest manufacturers of  
"ROGERS GOODS" in existence.

# LÉON J. GLAENZER & Co.,

80 and 82 Chambers St., New York.

---

**Novelties and Specialties in every Department.**

---

**Clocks.** Gilt, Porcelain, Enameled and Bronze, Crystal Regulators, Traveling Clocks, Hall Clocks with English Chime Movements.

**Bronzes.** Busts and Statues in real and imitation art Bronze and all the Novel Decorations.

**Lamps.** Banquet, Piano, and Princess Lamps, in Decorated Porcelain, Gilt Bronze and Enamel and other combinations.

**Fine Decorated Porcelains and Glassware.**

Sèvres Vases, Plates, Candlesticks, Inks, Flower Holders, Card Receivers, Etc. Table and Decorative Glass.

**Toilet Articles.** All kinds of Brushes, Manicure Sets, Hand Mirrors, Etc.

**Onyx Pedestals and Tables, Bric-à-Brac Cabinets.**

ALL GERMAN POTTERIES.

Dresden, Royal Bonn, Carlsbad, Teplitz, Etc., Etc.

## Now that we have touched bottom



And business generally is improving every GOOD RETAIL JEWELER should make his stock attractive and so invite customers. He can buy nothing more sure of sale than



of standard quality, at moderate cost, and of new and taking styles. If not called upon by our travelers send your orders direct to

**M. B. BRYANT & CO.,**  
10 MAIDEN LANE, NEW YORK.

**WM. SMITH & CO.,**  
Manufacturers of Gold, Silver and Roll Plate Chains and Jewelry.



Novelties in Gold and Silver Bead Necklaces and Bracelets. Also a large line of Chain Trimmings and Silver Rings.

Office: 5 and 7 Maiden Lane, New York.      Manufacturing: 61 Peck Street, Providence, R. I.

## A. J. HEDGES & CO.,

MANUFACTURERS OF

Gold, Variegated and Enameled Jewelry.

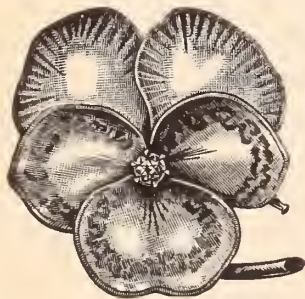

**BLACK AND WHITE ENAMELED GOODS**  
— A SPECIALTY. —

LACE PINS, SCARF PINS,  
BROOCHES AND PENDANTS,  
CHATELAINES AND BRACELETS,  
LINK BUTTONS AND STUDS,  
GOLD AND SILVER GARTERS

FACTORY;  
90 Mechanic St., Newark, N. J.

6 Maiden Lane, New York.

## L. SAUTER & CO.,

Dealers in Diamonds



... AND ...  
Makers of Fine Jewelry,

194 BROADWAY, NEW YORK.



Selection Packages sent on request. Mounting of Diamonds and other precious stones in new and original designs a specialty.

## Jewelry Fashions in Paris.

REPRODUCTIONS OF HISTORICAL CLOCKS—

THE GENIUS OF PLANCHON—JEWELRY FOR YOUNG WOMEN—THE FLEUR-DE-LIS AS A THEME—VARIOUS REIGNING STYLES.

PARIS, France, Oct. 25.—A Palais Royal clock maker (Planchon) who is known for his reproductions of historical clocks, has succeeded in executing all kinds of time pieces described or merely suggested in ancient books and manuscripts. He has reproduced most of the timepieces mentioned in Baron de Servièrè's book, published in the seventeenth century, although the aristocratic inventor, anxious to convey the belief that he had at his command supernatural means, carefully avoided giving an exact description of his works as regards the mechanism or acting power. Planchon, in solving these mechanical riddles, was led naturally to devise some thoroughly original pieces.

One of these consists of a hollow basin of oxidized silver containing water. The flat rim of this basin exhibits hour and minute marks running all round. Along the inside edge of the rim a tiny magnet moves regularly (by means of a hidden mechanism) so as to pass gradually near the different time divisions inscribed on the rim. A pretty little tortoise floating in the basin and provided with an unnoticeable piece of iron is attracted by the moving magnet, and consequently moves with it, thus pointing to the time.

The latest among these curious timepieces is constructed as follows: A sunflower of silver protrudes from a white crystal vase, graceful in shape and soberly decorated. The stalk is of brown gilt, the leaves green, the petals yellow and the heart of the flower deeply oxidized. Hour and minute marks are engraved around the heart of this sunflower which faces the looker-on. A lady-bird of spotted red enamelled gold apparently rests on the flower, on the line dividing the heart from the petals. This pretty insect, which moves imperceptibly by means of a mechanism hidden within the flower, shows the time. By only a close inspection can one detect the time divisions on this original dial which is granulated all over and is bluish black. As to the hollow circular line on which the lady-bird travels, it is completely invisible.

A pretty watch to wear hanging on the corsage consists of a lizard gracefully curled, and formed of emeralds. It holds in its mouth a diamond shell adorned with concentric rippling lines of rubies. In the center of this shell a tiny watch is half buried.

Articles of jewelry for young women do not admit of unlimited fancy. They ought as a rule to be of a perfect whiteness with subdued lustre. They may be slightly colored blue and pink, but the design must be very chaste or naïve. However, pretty articles sufficiently varied may be devised, even if we admit that the total ab-



*Point*

# MANUFACTURING GOLD AND SILVER PLATE.

COMPANY.

Rich  
Cut Glass.

*~ ~ ~*  
FINE  
DECORATED  
Art Wares.

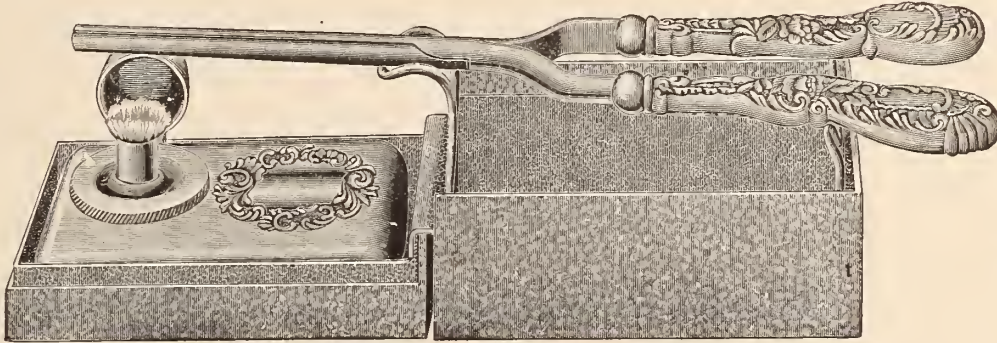

1880  
Flat Ware

*~ ~ ~*  
Our Latest Cata-  
logue [mailed to  
the TRADE upon  
[application. ]]

No. 6400. CURLING SET.

FACTORIES:  
New Bedford,  
Mass.

SALESROOMS: {  
New York, 46 Murray St.  
Chicago, 224 Wabash Avenue.  
San Francisco, 220 Sutter Street.  
Montreal, P. Q., St. James Street.

CROUCH & FITZGERALD.



Jewelry Trunks  
and Cases,  
161  
Broadway,  
Bet. Cortlandt and  
Liberty Sts.,  
688 B'way,  
701 6th Ave.,  
NEW YORK.

FLAT WARE AND  
HOLLOW WARE  
STAMPED



IS THE GENUINE.  
Manufactured by

WM. ROGERS M'F'G CO.,  
HARTFORD CONN.

ALBERT BERGER & CO.  
47 MAIDEN LANE, N. Y.  
Spectacles & Optical Goods,  
GROUND LENSES A SPECIALTY.

We sell to the legitimate Jewelry and Stationery  
trade only.



NEW YORK

CITY, U.S.A.

CHOICE PAPERS

MAKERS OF

FINE STATIONERY

For Correspondence, Wedding and Business Use, handsomely  
boxed, specially suited to the Jewelry Trade.

18 MURRAY STREET, NEW YORK.

# R. WALLACE & SONS MFG. CO.

## SILVERSMITHS,

WALLINGFORD, - - - - - CONN.



No. 20 CUTICLE KNIFE.



No. 20 CORN KNIFE.



No. 20 NAIL FILE.

Trade Mark.

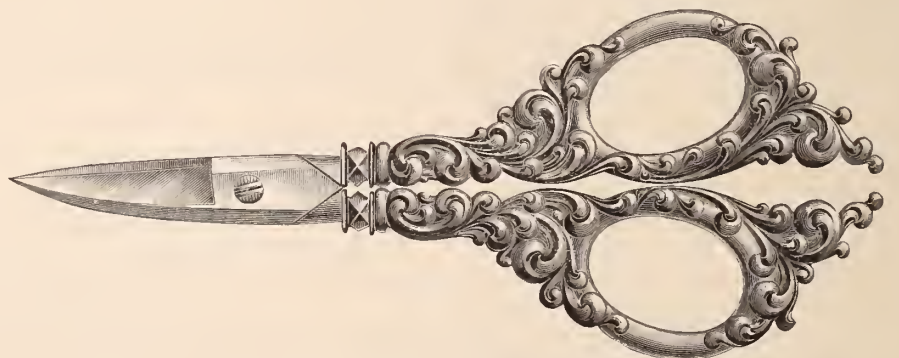

No. 20 NAIL SCISSORS.



No. 20 TWEEZERS.

NEW YORK,  
226 FIFTH AVENUE.

SAN FRANCISCO,  
120 SUTTER STREET.

CHICAGO,  
86 WABASH AVENUE.

sence of color is to be the rule. Sober rosacæ consisting of brilliants flatly set, and of tiny white pearls mounted on silver or platina, give the intended effect; the mounting should be coated with pure, snowy silver. A cherub's head with wings, caught within a narrow circle, or a plunging dove is also an appropriate pattern, as well as a myosotis formed of minuscule turquoises and brilliants, or the portrait of Joan of Arc faintly marked in frosted silver, bordered with seed-like pearls.

*Motifs* vaguely reminding us of a cross or a fleur-de-lis, in silver, with a tasteful opposition of frosting, *gratebossé*, and polishing, answer as well. A floweret reproduced in tender-colored enamel, soberly treated on a white ground, is also a suitable pattern. I have seen in this line some bracelets, brooches, earrings, shoe buckles, and hair combs, which, in spite of being remarkable pieces of jewelry, would not glitter at a *bal blanc*.

One of the themes on which a jeweler may constantly execute new variations, with unailing success, is the fleur-de-lis. Brooches in the shape of a fleur-de-lis are always fashionable. One is in frosted silver, the nerves of the flower being well marked, and the petals showing very faint longitudinal swellings true to nature; a large and well faceted diamond sparkles in the center. Another consists of elongated emeralds, one for each petal, bordered with brilliants. A third has its

petals in pale gold split from the base upwards, disclosing two rows of tiny pearls running close together in the empty space, so that the fleur-de-lis seems to frame a pearl cross.

Ladies' rings are adorned with a fleur-de-lis, each petal of which consists of a pear shaped diamond, excepting the top one, which is a turquoise or an opal. The unaccountable prejudice which so long caused the latter stone to be neglected is thoroughly overcome. We see, in some of the best jewelry stores, brooches, rings, earrings, studs, bracelets, buckles, umbrella tops, etc., exhibiting opals, circled with minuscule diamonds.

Fashionable gentlemen's rings are of dull pale gold, very massive and adorned with a large ruby, emerald or sapphire in *cabochon*, flanked with two diamonds.

A pretty ornament for the hair is a bird in varicolored stones with displayed wings, holding in its beak a diamond corn stalk or a small feather.

JASEUR.

#### Organized Plans to Make Our Coins Artistic.

The Joint Committee on the Improvement of the United States Coinage met Tuesday evening last at the rooms of the American Numismatic and Archaeological Society, 17 W. 43d St., New York. The committee has for its object the periodical adoption of artistic designs for the coins of the country,

symbolic of historical events. Daniel Parish, of the American Numismatic and Archaeological Society, presided at the meeting in the absence of Russell Sturgis. George F. Kunz, of the same society, secretary, stated that he had called upon Mr. Preston, superintendent of the Mint at Philadelphia, who said he was of the opinion that an open competition would secure the best results.

Mr. Kunz advocated that the committee use its influence to have \$5,000 appropriated for equal division for the ten best awards, the successful design to be chosen from among the ten. The suggestions made last April by the sub-committee were approved with some changes. The plan of the committee is to make a selection of ancient and current coins for the purpose of drawing a comparison between them and the Government coins, and to submit the result to a United States Senator. After the necessary enactments and appropriations, a jury composed of ten sculptors, two numismatists, and a Government official is to be selected to pass judgment upon the designs submitted.

The competition will be open to every artist in the world. The committee recommended that the changes in the designs be made at each change in the Administration, or every ten years. Mr. Kunz believes that the cost of producing artistic designs upon the coins would not amount to \$50,000 for every change.

The following societies and institutions



# RICE & HOCHSTER,

MANUFACTURERS OF

## Tortoise Shell Goods

No. 485 BROADWAY,

NEW YORK.

*Spanish High Top Combs and Side Combs  
Our Specialty.*

**NOTICE.—WE ARE THE ORIGINATORS OF  
TORTOISE SHELL HAIR ORNAMENTS WITH  
STERLING SILVER DEPOSIT.**

**WE ISSUE NO CATALOGUE.**

# JOS. F. CHATELLIER,

860 BROADWAY, NEW YORK,

## Manufacturer of GOLD AND SILVER JEWELRY.

The Only Manufacturer in Gold and Silver

OF THE

# BOSTON GARTER.



### OUR NEW PATENT CLASP

FOR

## Ladies' and Gentlemen's Hose Supporters,

(As Illustrated.)

Is the most practically perfect and convenient yet offered to the trade.

We are also the exclusive makers by secured rights of

## The Lindsay Patent Loop and Button Fastener.

MADE ONLY IN STERLING SILVER AND 14K. GOLD.

# CARBORUNDUM.

## Net Retail Price List of Carborundum Wheels.

ACEESON'S PATENT, February 28th, 1893.

Diam. in Inches	THICKNESS IN INCHES.																	Rev. per Minute.
	1/4	3/8	1/2	5/8	3/4	7/8	1	1 1/4	1 1/2	1 3/4	2	2 1/4	2 1/2	2 3/4	3	3 1/2	4	
1	\$.15	\$.18	\$.20	\$.23	\$.25	\$.28	\$.30	\$.35	\$.40	\$.45	\$.50	\$.55	\$.60	\$.65	\$.70	\$.80	\$.90	18,000
1 1/2	.18	.22	.25	.28	.31	.33	.35	.40	.45	.50	.56	.62	.67	.73	.78	.90	1.00	14,000
2	.20	.25	.30	.34	.37	.40	.42	.46	.52	.58	.65	.70	.77	.85	.90	1.00	1.20	11,000
2 1/2	.25	.30	.37	.42	.46	.48	.50	.55	.60	.67	.75	.80	.89	.98	1.05	1.20	1.40	8,800
3	.30	.38	.45	.50	.55	.58	.60	.65	.70	.78	.85	.95	1.05	1.15	1.25	1.45	1.65	7,400
4	.35	.40	.45	.50	.55	.58	.60	.65	.70	.78	.85	.95	1.05	1.15	1.25	1.45	1.65	6,400
5	.40	.45	.50	.55	.60	.65	.70	.75	.80	.85	.90	1.00	1.10	1.20	1.35	1.50	1.70	5,500
6	.45	.50	.55	.60	.65	.70	.75	.80	.85	.90	1.00	1.10	1.20	1.35	1.50	1.70	1.90	4,800
7	.50	.55	.60	.65	.70	.75	.80	.85	.90	1.00	1.10	1.20	1.35	1.50	1.70	1.90	2.10	4,200
8	.55	.60	.65	.70	.75	.80	.85	.90	1.00	1.10	1.20	1.35	1.50	1.70	1.90	2.10	2.30	3,700
9	.60	.65	.70	.75	.80	.85	.90	1.00	1.10	1.20	1.35	1.50	1.70	1.90	2.10	2.30	2.50	3,200
10	.65	.70	.75	.80	.85	.90	1.00	1.10	1.20	1.35	1.50	1.70	1.90	2.10	2.30	2.50	2.70	2,800
11	.70	.75	.80	.85	.90	1.00	1.10	1.20	1.35	1.50	1.70	1.90	2.10	2.30	2.50	2.70	2.90	2,400
12	.75	.80	.85	.90	1.00	1.10	1.20	1.35	1.50	1.70	1.90	2.10	2.30	2.50	2.70	2.90	3.10	2,000

CARBORUNDUM was awarded both a Medal and a Diploma at the World's Columbian Exposition in recognition of its merits as an Abrasive, the hardness being greater than any other abrasive material.

The wheels are made with a vitrified bond, and pressed under hydraulic pressure. Those over three inches in diameter are turned up after firing. The same numbers are used to designate the degrees of fineness, as are used with Emery, and the wheels are made in seven degrees of hardness, marked SSS, SS, S, M, H, HH, HHH, from extremely soft to extremely hard.

In ordering, state diameter, thickness, hole, number and hardness.

Monongahela, Pa., U. S. A.

THE CARBORUNDUM COMPANY.

Hones, Slabs, Files.

Cut = This = Out.

IMPORTERS OF  
**DIAMONDS.**

JOBBER'S IN

Watches, Jewelry, Chains,  
NOVELTIES, ETC.

Latest Designs. Lowest Prices.

**AIKIN-LAMBERT  
JEWELRY CO.,**

19 Maiden Lane, New York.

CHICAGO BRANCH: 103 STATE ST.

are represented in the work : The American Numismatic and Archæological Society, College of the City of New York, the the Architectural League of New York, National Academy of Design, the National Sculpture Society, the Society of American Artists, the Cincinnati Museum Association and the Pennsylvania Academy of Fine Arts of Philadelphia.

**It was Probably the Oldest Clock Factory in the United States.**

FORESTVILLE, Conn., Oct. 24.—The clock factory, in Forestville which workmen were engaged in tearing down last week, was probably the oldest in the United States. Wooden clocks were made there as early as 1811 by Chauncey Boardman and later by the firm of Boardman & Buckley.

The present owner is Thomas Ashworth. The building was very much dilapidated. The nails used in its construction were the old fashioned hand-made nails. The bushings and jewels of the clocks were then of bone. The clocks were sold as soon as made, if possible, and at one time a stock of four being unsold the company was in danger of being compelled to shut down.

**Impressive Memorial Exercises in Honor of Isaac C. Lewis.**

MERIDEN, Conn., Oct. 20.—The memorial services in St. Paul's Universalist Church last evening in honor of the late Isaac C. Lewis, who was president of the Meriden

Britannia Co. and one of the founders of that company, were very largely attended and were extremely interesting. Rev. Dr. Perkins paid a glowing tribute to the noble life of Mr. Lewis, and said that the church chime, about to be rung for the first time in this city, was the gift of Mrs. I. C. Lewis, who was only carrying out the principle followed by her husband, of seeking to do the greatest good to the greatest number. The chimes were made by Meneely and cost \$10,000. There are 13 bells, the largest weighing 3,500 pounds. The ringing of the chimes was a notable event in Meriden and the great topic of the evening. The chimes were rung on the first anniversary of Mr. Lewis' death.

**R. F. Simmons Makes Many Bequests.**

ATTLEBORO, Mass., Oct. 27.—The will of Robert F. Simmons was on Wednesday presented for probate in the Taunton court. In this as in his life, his tendencies toward benevolence are noticed. He remembered those who had been in his employ and faithful for any length of time. Joseph L. Sweet, Edward R. Price and George A. Adams are named as executors.

Some of the bequests are as follows: To Mrs. S. E. Fisher, \$5,000; to the town of North Attleboro \$8,000 on condition that it lays out, curbs and establishes a public park within two years on the triangle at Attleboro Falls, the same to be known as Simmons Park; to the trustees of Tuft's

College \$2,000 to establish a scholarship to be known as the Mary T. Simmons scholarship; also \$2,000 to the same college to establish the Robert F. Simmons scholarship; to S. E. Fisher \$2,000; for the care of his famous horse, Del Monte, \$3,000; to Mary Sleeper, employe of R. F. Simmons & Co., \$1,500; to Edward R. Richardson, book-keeper of the firm, \$500; to his next of kin \$15,000, share and share alike; Mrs. William Stanley, Milwaukee, Wis., in trust for her children \$8,000; Sadie Fisher, daughter of S. E. Fisher, \$2,500.

Other bequests were : Christian Klee, an employe \$500; Joseph Coddling, E. L. Evans, Sarah C. Clark, Mary, Louise and Helen Stone, Ada R. Evans, Frederick Burden, The Attleboro Agricultural Association, Lina Blackinton, E. F. Burden, Estelle Sloan, of New York, and Emma Blackinton, \$500 each. Joseph L. Sweet will receive \$5,000, George A. Adams and Edward R. Price \$1,000.

The trustees of the Mount Hope Cemetery are allowed \$1,250 for beautifying that place. His diamonds and library go to C. G. Emery and daughter, of New York, and the remainder of the estate, including fine art works, the mansion, etc., are to be sold or disposed of as the executors see fit.

Frank Fisher, for years with Reed & Barton, Taunton, Mass., has accepted a position as foreman of the silver room of the Howard Sterling Co., Providence.

ALL KINDS

FANCY WOOD

CHESTS

FOR

TEA SETS

AND

FLAT WARE.



FANCY KID,

CHAMOIS,

SILKS and

BROCADE

CASES,

FOR

SILVER WARE

AND

JEWELRY.

HEBBARD & BROTHER,

860 BROADWAY,

NEW YORK.

### May an Employe Substitute an Equivalent for an Article?

BALTIMORE, Md., Oct. 24.—Two of the five men who were arrested last August on the charge of being implicated in robbing the firm of Samuel Kirk & Son, of silverware variously estimated to be worth from \$5,000 to \$15,000, were tried in the criminal court yesterday. The case of Peter H. Keelan was first taken up. The case of Llewellyn Walker was also tried, and he was found not guilty, the court declining to hear any testimony produced by the defense as no evidence had been brought forward to prove that Mr. Walker was guilty.

Mr. Keelan is a spoonmaker, and was employed by Samuel Kirk & Son for nearly 10 years. He is charged with the larceny of half a dozen silver spoons. Henry C. Kirk, Jr., and Detective Miller were the principal witnesses against him. Mr. Kirk testified that the firm had lost a great deal of silver and suspected some of the workmen employed by them. On the night of July 31, after the men had gone, he went in company with the detective to the workroom and counted and weighed the contents of the unfinished work left by Mr. Keelan. The evening following they again went to the room and found that half a dozen silver spoons were missing from the bucket in which Keelan placed his work when he left the shop that night. Upon information received Detective Miller went to the house of Meary Kachele, an engraver,

who lives on Gay St., near Saratoga, and demanded the spoons. Six silver spoons were handed over to him and Mr. Keelan was arrested. He was released on bail.

Keelan, in his testimony, did not deny that he had taken the spoons to the house of Kachele. He said in explanation, however, that they were the property of Mrs. Kachele. She had given him eight ounces of silver filings, and he had made the spoons in his leisure hours when work was slack. He did not deny that he had used silver belonging to Mr. Kirk to make the spoons, but claimed that after having made them he put them in a balance and placed the filings given him by Mrs. Kachele on another balance. He then placed filings of the same weight in the box of silver filings belonging to Mr. Kirk. He declared emphatically that he had not robbed the firm of a pennyweight, but had given them value received. Mrs. Kachele corroborated the story told by the accused.

Mr. Kirk was recalled, and testified that even if eight ounces of filings had been put in those belonging to him it would not have repaid the firm for the silver used in making the spoons. Silver, he said, was worth 64 cents an ounce, and filings but 25 or 30 cents. The spoons weighed nearly seven ounces. When asked where she had procured the filings, Mrs. Kachele testified that her husband was an engraver on silver and she had saved the filings from his work bench for years for the purpose of having a set of spoons made.

The case was submitted to Judge Harlan without argument, and he held it under consideration. Admitting for the purpose of argument, he said, that Keelan had put the eight ounces of filings in the box of filings belonging to Mr. Kirk, in payment for the silver used in making the spoons, it was a question of law whether a man can take an article from his employer without his consent and leave something which he considered its equivalent in its place. It was a question whether this would constitute the crime of larceny. Robert Crain, the counsel for Keelan, said that he did not see how it could, as the law expressly provides that to constitute the crime of larceny there must be an intent to steal, and no such intent had been shown.

### Killed by an Electric Shock Intended for Burglars.

UTICA, N. Y., Oct. 25.—Stewart A. England, aged 17 years, was instantly killed tonight by a shock of electricity received from the combination knob of jeweler Bernard Goldstein's safe. The jeweler had connected the safe with the wire furnishing current to the motor running his lathe, as a protection against burglars.

England and a companion were in the store examining some goods, and the latter dared England to touch the knob. He touched the combination and immediately fell dead.

# PRINCETON WATCHES

ARE THE LATEST TRIUMPH IN WATCHMAKING,

And are especially designed for reputable watch dealers desiring a well made, finely finished and reliable watch, which will afford a fair return for time and capital invested, and which the public do not know more about than the dealer.

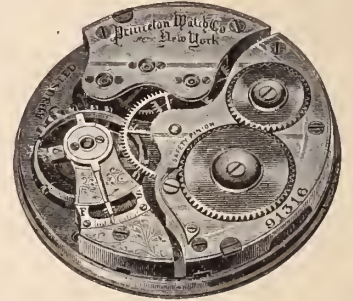
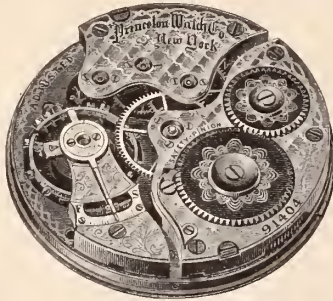
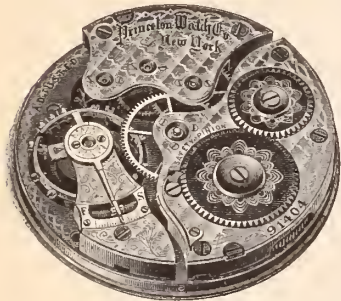

16 size, thin model, fitting Elgin size cases Open Face and Hunting S. W. Open Face are Pendant Set.

Three Grades—Solid Nickel Movement, beautifully damaskeened and finely finished throughout; 15, 16 and 17 Ruby Jewels in Settings; Accurately Adjusted to Temperature, Isochronism and Positions; Breguet Hair Spring; Exposed Pallets; Micrometer Regulator; Safety Center Pinion; Fine Glass Enamel Dial—and at prices which are attractive.

These movements are made in Geneva, Switzerland, by the most improved American automatic machinery, insuring accuracy and precision, and finished by Swiss skilled labor, giving to them that delicacy of finish so much admired. In the selection of jewels, dials and all material, everything is of the very best.

In placing Princeton Watches on the market, it is with full confidence that their superior construction, delicacy of finish and accuracy of performance will meet with the highest appreciation by the trade.

**THEY ARE SUPERIOR TO ANY WATCH IN THE MARKET, AND AT LOWER PRICES.**

Distributed to the Retail Trade through a limited number of Jobbers as Wholesale Agents, under contract governing sale and protecting the Retailer. Ask your jobber for them. If he does not keep them, write us and we will give you names of jobbers who do.

Illustrated and Descriptive Price Lists sent to Regular Jewelers upon application.

In selling Princeton watches you consult the best interests of your customers and at the same time

**MAKE PROFITS FOR YOURSELF.**

**A. C. SMITH WATCH CO.,**

**177 Broadway, New York.**

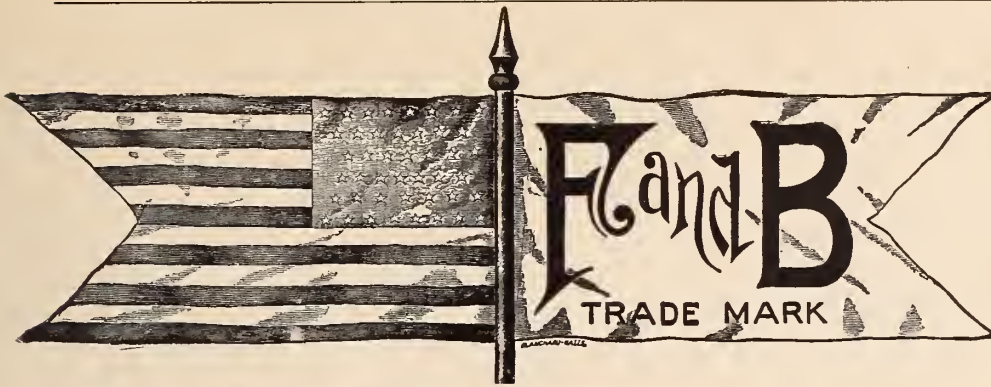

# FOSTER & BAILEY,

100 RICHMOND ST.,

PROVIDENCE, R. I.

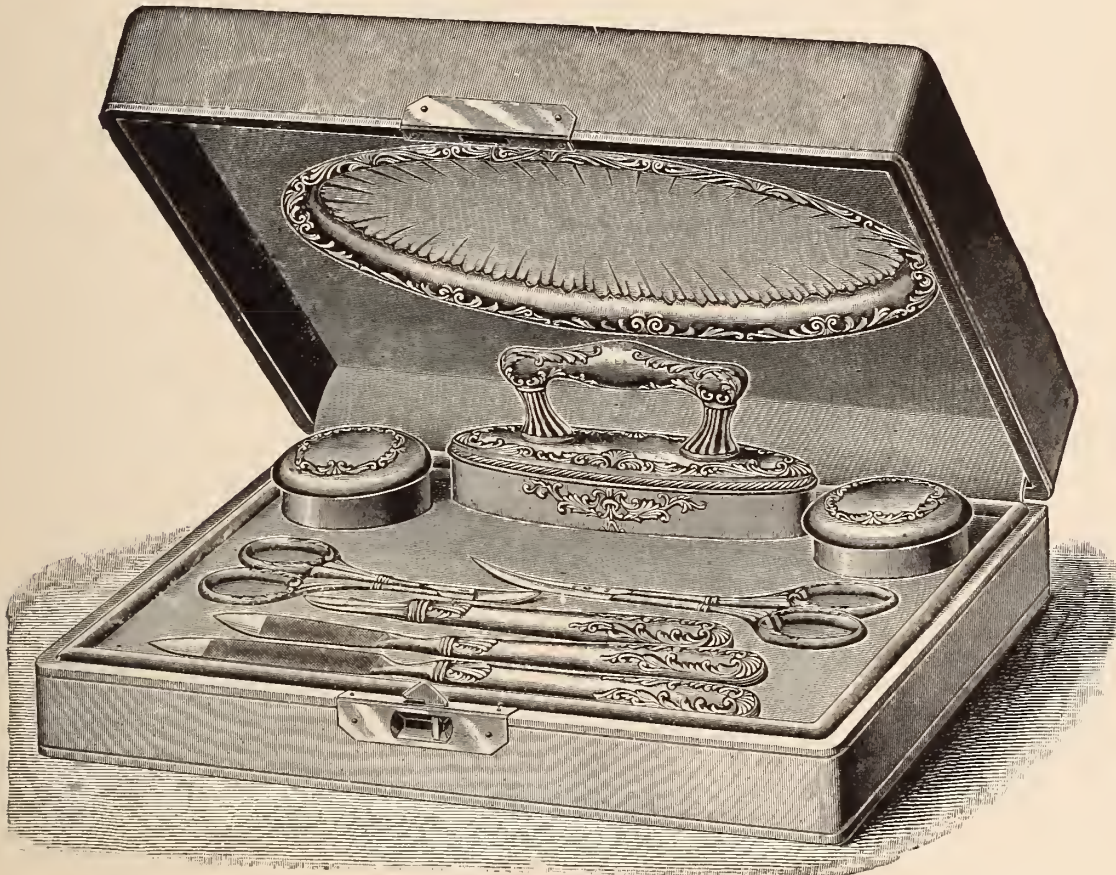

ONE QUARTER SIZE.

Be sure and see the Manicure Goods that we have just put out. This cut shows a set in a nice box, lined with Chamois, and is a quarter size. **Beautiful Goods.** The steel parts are made by the famous **Henckles**, of Germany, and are considered the best in the world. We make the goods in Sterling Silver and also in Tenth Gold, and at such a low price! The goods are boxed just right, so that a traveler can carry them in a trunk, and take up but little room. Sets without the large tray and buffer box and others with less pieces at low prices.

No. 1, 2, 3 is Sterling Silver. No. 4, 5, 6 Tenth Gold. Every piece is numbered and can be ordered separate, and at prices that will sell the goods. We make a specialty of Sterling Silver Novelties, comprising

Match Boxes, Manicure Articles, Shoe Buttoners, Embroidery Scissors, Garters, Paper Cutters, Ladies' Seals, Etc. All  $\frac{925}{1000}$  Fine.

#### Rolled Plate Watch Chains

Our Chains can be safely sold to the best trade, and guaranteed as superior quality. No chance of poor quality where chains are stamped F. & B.

#### Gold Vest and Dickens Chain

Soldered with 10 K. Gold Solder. Will assay 1-10 Gold.

#### Chain Mountings

We are headquarters, and make everything in this line.

#### "Mount Hope" Buttons

Superior to any button in the world. Easy to put in and take out of the cuff.

#### Solid Gold Locket

With Diamonds and without. This is a beautiful line and solid throughout.

#### Link Buttons

We are making some very pretty styles in Roman, chased, engraved and plain, with and without stones, Sterling Silver and Rolled Plate.

#### Locket and Charms

We make them in endless variety.

#### Sterling Silver Goods

Match Boxes, Manicure Articles, Shoe Buttoners, Embroidery Scissors, Garters, Paper Cutters, Ladies' Seals, and various novelties, all  $\frac{925}{1000}$  fine.

#### Bracelets

Curb Bracelets in all sizes, with padlocks and snaps, chased and plain polished, Roman, rolled silver plate and sterling silver. We make padlocks with keys and also with a push snap, which are very popular.

#### Neck Chains and Lorgnette Chains

#### Pins

Lace and Cuff Pins, with gold fronts, engraved; also trimmed pins, Scarf Pins. Baby Pins with Chain. Also Baby Buttons with Chain. Sword Pins with Scabbard and Chain. Belt Pins.

#### Glove Buttoners

#### Crosses

Four sizes of gold filled in plain, engraved, and set with stones.

#### Earrings

A nice line in engraved and trimmed. Eye Glass Chains in Gold and Plate. We received four awards and a medal at World's Fair.

## JEWELERS ORGANIZING THROUGHOUT NEW ENGLAND.

### The Connecticut Jewelers' and Opticians' Association Formed.

NEW HAVEN, Conn., Oct. 26.—Representatives of leading jewelry firms of Connecticut met at 11 o'clock yesterday morning at the New Haven House and formed a State association. About a month ago the leading jewelers of this city met and organized the New Haven Retail Jewelers' Association, with Gen. George H. Ford, of this city, as president. At that time and at a similar meeting of Hartford jewelers, a movement was proposed to secure legislative aid in protecting the trade against certain abuses, and in order to represent the jewelers of the whole State, it was decided to call a meeting of the principal jewelers of the State. Accordingly an invitation was sent out for such a meeting to be held in this city.

General Ford called the meeting to order and he was elected chairman, with Chas. R. Hansel, of Hartford, secretary. Among those present were the following:

Chris. Strobel, Waterbury; F. H. Brown, Meriden; Homer B. Hoyt, South Norwalk; R. N. Johnquest, Ansonia; S. H. Wood, New Britain; Scovill Hitchcock, Southington; Major C. H. Case, Hartford, who is president of the Hartford Association; S. H. Kirby, New Haven; Willis D. Upson, Waterbury; H. G. Oliphant, Bridgeport; J. C. Tracy, Willimantic; Andrew Tracy, J. H. G. Durant, C. E. Katsch, C. R. Welch, Mr. Wells, of Wells & Gunde, A. Silverthau, E. L. Glouskin, E. Zernitz, D. C. Winans, Benjamin Silverthau, C. M. Parker, all of New Haven; S. Kronholtz, Stamford; John H. Reid, Bridgeport; W. J. Steven, F. E. Shaw and H. A. Deming, Hartford; W. Austin, Norwalk; and W. F. Sternberg, New Haven.

The scope of the association was decided to be as follows: "This association is organized for the purpose of protecting the interests of the legitimate retail jewelers in the State of Connecticut against the evils and abuses that exist in the trade, and for the purpose of elevating and maintaining the profession of the jeweler to the highest standard in the mercantile world. To advocate in the Legislature of this State the passage of what is known as the sterling law—stamping of gold and silver. To assist other associations in advocating the passage of the law that will make it a misdemeanor for a manufacturer to stamp any article of gold of a higher karat or silver of a higher grade than it really is."

An address was made by Newton Dexter, of the New York State Jewelers' Association, in which he made these recommendations:

"Ask your Legislature to give you a law that will make the manufacturer stamp his sterling 925-1000 S. F. and his gold correct

karat under the penalty of a heavy fine or imprisonment, or both, in the discretion of the judge, such a law being in the interest of the purchaser. A law would make it impossible to palm off upon the public watch cases with only sixty-two cents' worth of gold in them; impossible to palm off a one-karat case under the name of pre-determined, or eight karat unless they assayed that minus the little lost in the assay."

General Ford commended the recommendations in the address and had no doubt that if carried into effect the trade would be greatly benefitted.

A motion was made to organize the Connecticut Jewelers' Association, but upon an amendment offered by Mr. Parker, of this city, it was decided to include opticians. A constitution was adopted for the Connecticut Jewelers' and Opticians' Association, and the members then adjourned for dinner.

The following officers were elected at the afternoon session: President, Gen. George H. Ford, New Haven; first vice-president, Major C. H. Case, Hartford; second vice-president, Chris. Strobel, Waterbury; secretary, C. R. Hansel, Hartford; treasurer, A. W. Austin, Norwalk; board of directors: S. H. Wood, New Britain; F. H. Brown, Meriden; C. M. Parker, New Haven; F. E. Harvey, Hartford; J. C. Tracy, Willimantic; F. J. Breckbill, Bridgeport.

### The Jewelers of Worcester Have the Fever of Organization

WORCESTER, Mass., Oct. 24.—At the Bay State House Friday evening, Oct. 19, members of nearly all the jewelry and optical firms in the city met and took preliminary steps toward the organization of an association for the protection of themselves and the public from the many abuses of the trade.

Newton Dexter, the promoter of the scheme, was present and outlined the plan of organization. It is desired to have the Legislature of each State enact laws requiring all auction sales of jewelry to take place between sunrise and sunset; to place the granting of peddlers' licenses in the hands of selectmen and city officials; to make it a crime for one dealer to libel another in his advertisements; to make all sterling silver grades put upon the market assay .925 fine. Congress will be asked to make a law making it a state prison offense to stamp goods with other than the actual karat and pennyweight.

A committee consisting of W. H. Robinson, Nelson H. Davis, Frank R. Hayden, William T. Pratt, Alvin C. Bruce and C. M. McFarland was chosen to send out circulars to every legitimate jeweler and optician in the county requesting them to

be present at a meeting which will be held in the city on the afternoon of Oct. 31, for final organization.

### An Organization Aimed at the Eastern Manufacturers.

PROVIDENCE, R. I., Oct. 25.—A meeting of the members of the local legitimate retail jewelers was held last evening, at Narragansett Hotel, for the purpose of forming an organization to correct existing trade abuses. In response to the call about forty gentlemen assembled, and at the appointed hour all those who were not representatives of the "legitimate retail trade" were requested to retire, newspaper men being barred with the rest, and the session was held with closed doors.

Newton Dexter called the meeting to order and officiated as chairman. He addressed the meeting at some length, discussing trade abuses and their remedies, as would be made possible through the united action of the retail dealers. Among the abuses mentioned were the selling of jewelry by the manufacturers to dry goods and fancy goods' dealers, and the selling of watches and diamonds by employes of manufacturing houses. He also touched upon the benefits New York retailers have received from legislation enacted in their behalf. In that State they have already laws that mean many thousands of dollars to them, and it is claimed that the retail jewelers of this State can have the same laws if they will but ask for them.

After outlining the work desired to be accomplished and the methods taken by other associations in organizing, the meeting was thrown open for a general discussion of trade abuses as experienced by those present. A majority of those present entered into the discussion and many funny things were elucidated. One of the most prominent features touched upon was that certain manufacturing concerns were in the habit of allowing their employes to have goods at the wholesale prices and that they sold the same to their friends at prices far below what the retailer could possibly afford to sell for. It was shown that another abuse that the retailers had to contend with was manufacturers who took watches from jobbers in payment for goods and then got rid of them in any way they could.

It was decided to form a permanent organization and the following committee was appointed to make the necessary preliminary arrangements: Saati Bros., Herman Ockel, George M. Kittredge, Thomas F. Mullen, D. C. Fink, Dexter Chevers, Jacob Farrington, L. D. Nelson, A. D. Wilson and B. F. Fox. It was voted to call another meeting on Friday evening, November 2d, to perfect arrangements for organization.



# VICTORIA.

PATENTED SEPTEMBER, 1894.

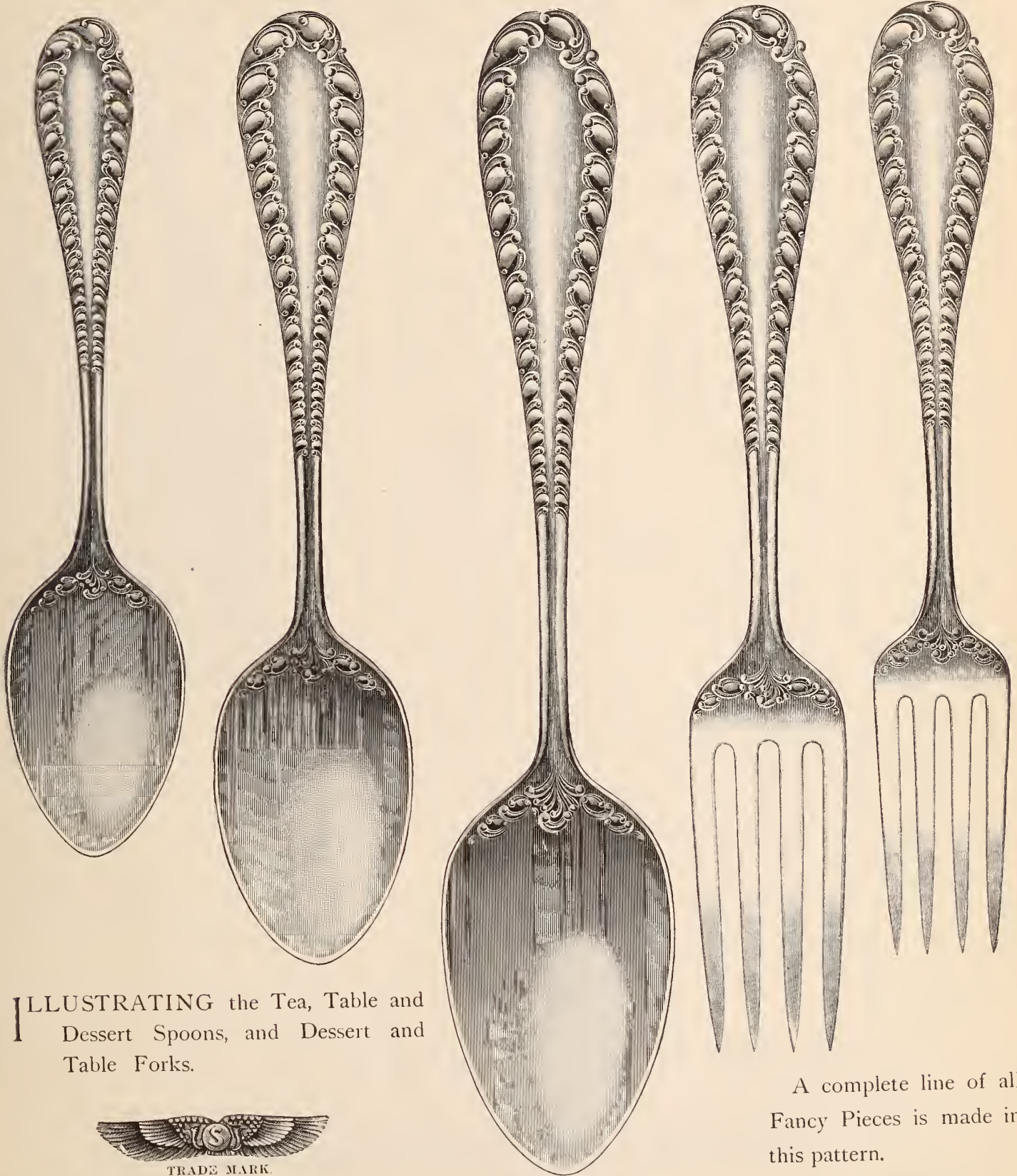

ILLUSTRATING the Tea, Table and  
Dessert Spoons, and Dessert and  
Table Forks.

A complete line of all  
Fancy Pieces is made in  
this pattern.



**Geo. W. Shiebler Co., Silversmiths, 179 Broadway, N. Y.**

ESTABLISHED 1843.

Highest Awards in Every Competition

# LEROY W. FAIRCHILD & Co.

3 Maiden Lane, New York City.

## Gold Pens, Gold and Silver Pencils and Pen Cases,

The Handsomest and Cheapest Line of Goods in the Market.

WORKS: 3D AVENUE AND OGDEN ST., NEWARK, N. J.

### FANCY

.. IN ..

SCARF PINS

AND LINKS.



### FIGURES

STERLING SILVER,

Enameled in Colors.

Dudes, Chinamen, Policemen, Sailors, Orators, Cadets, and all other Shapes Made.

SEND FOR SAMPLES.

QUICK SELLERS.

If your Stock does not include our **GOLCONDA GEM** Line you are losing sales. This Stone is Mounted in Studs, Scarf Pins, etc., in Solid Gold and Plate.

If your jobber doesn't keep these goods write us and we will send you the address of a jobber in your vicinity who does. Every card bears the words "THE GOI CONDA GEM, Reg'd." all others said to be "equally as good" are spurious. Bear this fact in mind.

R. L. GRIFFITH & SON, = PROVIDENCE, R. I.

..THE LATEST..

Sterling Silver Novelty,

CIGAR CUTTER

AND KEY RING COMBINED.

(Patent applied for.)

WITH OR WITHOUT CHAIN.

MADE ONLY BY

ENOS RICHARDSON & CO.,

23 Maiden Lane, New York.



### SAFES FOR JEWELERS.

MOSLER, BAHMANN & CO., 518 BROADWAY  
NEW YORK.

Patent Fire and Burglar Proof Safes.

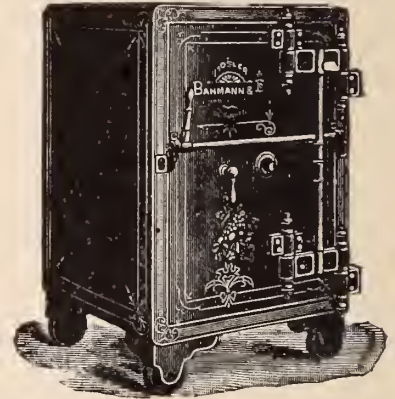

Large Assortment Always on Hand.  
Send for our Representative.  
Special Safes to Order.  
Jewelers' Safes a Specialty.

THEODORE C. STEINHAUS,

— MANUFACTURER OF —

Fine Cases and Trays

For JEWELRY, SILVERWARE, &c.  
SAMPLE CASES AND TRAYS FOR TRAVELERS.

Fancy Hard Wood Chests for Silverware, &c.  
Linings, Cushions, Mounting, etc., for Silver Novelties,

10 MAIDEN LANE, NEW YORK.

## AIKIN, LAMBERT & CO.,

CHICAGO BRANCH: 103 State Street.

No. 19 MAIDEN LANE, NEW YORK.

Manufacturers and Exporters  
Gold Pens, Holders, Pencils,



Toothpicks and Novelties.

MERCANTILE



FOUNTAIN PEN.

**The Death of Reuben Scott Middleton.**

An old and well known member of the jewelry trade passed away Monday, Oct. 22d, when Reuben Scott Middleton died of pneumonia at his residence, 14 E. 65th St., New York. Mr. Middleton, who was



REUBEN SCOTT MIDDLETON.

the senior member of the firm of Middleton & Brother, dealers in diamonds and watches, 10 Maiden Lane, had been in the jewelry business for about fifty years.

Deceased was a native of New York State being born at Black River, Jefferson Co., Feb. 16, 1822. When a young man he went to New York city about 1844, and found employment with Du Bois & Co., importers of watches, on Nassau St. He was subsequently employed by jewelry firms in New York and other cities until 1851, when he became a partner in the firm of Saltzman; Middleton & Co., importers of watches, 10 Maiden Lane. The company in this firm was a Mr. Pooler, with whom Mr. Middleton, three years later, in 1854, formed the firm of Middleton & Pooler which continued until 1865.

The next year Mr. Middleton and his brother John D. Middleton formed the partnership known as Middleton & Brother, which has continued ever since. The business, it is expected will be continued under the old firm name by Jno. D. Middleton and the executors of the deceased.

Mr. Middleton was known to his friends and associates as a man whose character was above reproach. He was a plain man, of modest temperament, who neither sought nor cared for notoriety in any degree. In business he had the reputation of being a careful and diligent worker whose word was as good as his bond. His strict honesty and sterling qualities gained for him the admiration and respect of all with whom he came in contact. He leaves a widow and two married daughters.

The funeral, which was private, took place from his late residence Thursday.

The remains were interred at the family plot in Greenwood Cemetery.

**The New York Jewelers' Board of Trade Will Hold Their Annual Banquet.**

The New York Jewelers' Board of Trade will hold their annual banquet this Winter. The matter was decided upon at a special meeting, Oct. 23d, and the following banquet committee was appointed: E. V. Clergue, of the E. Howard Watch & Clock Co., chairman; T. K. Benton, of the Courvoisier-Wilcox Mfg. Co.; Leo Wormser, of the Julius King Optical Co.; David Keller, of Keller, Ettinger & Fink; Geo. W. Vandeventer, of the Waterbury Clock Co.; Wm. I. Rosenfeld; Samuel Wallach, of Wallach & Schiele; August Oppenheimer, of Oppenheimer Bros. & Veith; and the president, A. J. G. Hodenpyl, of Hodenpyl & Sons, *ex-officio*.

At the same meeting the resignation of L. Lilienthal, as a director in the Board was accepted, and Samuel Wallach, of Wallach & Schiele, was elected in his place. The banquet committee has not yet decided upon the date for the banquet.

**The Jewelers' League.**

The last assessment sent out from the Jewelers' League on Oct. 12th, we note, can be paid in two instalments. Members wishing to avail themselves of this favor should keep it in mind. The assessment closes on Dec. 12th, and will no doubt be the last for the year.

**Burglars Have an Easy Time Robbing the United States Optical Co.**

DETROIT, Mich., Oct. 26—The building occupied by the United States Optical Co. was entered at an early hour yesterday morning, and a good sized haul made. It consisted of 52 dozen gold filled frame eyeglasses, valued at \$398.50.

The front of the building is only partially completed and it was an easy job for the burglars to cut out a pane of glass, move the catch and raise the window. They knew where to look for the most valuable goods in the shipping room. It is thought that they might have been some itinerant peddlers who frequently buy goods in person.

**The Shoplifters Were Frightened by an Advertisement.**

POTTSTOWN, Pa., Oct. 24.—The jewelry stores of Aaron Hartenstein, Jr., Wm. L. Stone, Edmund Kerper and C. W. Ritter were visited by two young women, who managed, while looking at goods, to carry off a lot of rings, chains and other jewelry.

After the loss was discovered a newspaper advertisement, pointedly threatening prosecution, frightened one of the females into a confession, and the shoplifters returned all the articles. On account of family connections who are quite respectable, the parties will not be arrested.

# KUTE

That is what everybody  
says about our

## Patented Cane.... Stick Pins,

which we have the exclusive  
right to make in

## Solid Gold and Sterling Silver Heads.

EVERYBODY likes them.

EVERYBODY wants them.

EVERYBODY buys them.

EVERYBODY wears them.

Order at once of your  
Jobber.

# WAITE, THRESHER COMPANY.



# Perfect Construction

AND

## SUPERIOR FINISH

MAKE OUR PRODUCTIONS OF  
HIGHEST GRADE.

JEWELERS and  
FANCY GOODS DEALERS  
will find in our new line of

### Art Metal Goods

many articles specially adapted  
to their trade.



#### The Finest Line of Banquet Lamps

EVER PRODUCED.

Fitted with the Celebrated "B. & H." Burner.

New and Attractive Designs and Finishes. Sure to be Ready Sellers.

We will send you our Little Book, giving more information, if you desire, and will be glad to have you visit our Salesrooms and see the Goods.

## BRADLEY & HUBBARD MFG. CO.,

NEW YORK, PHILADELPHIA, BOSTON, CHICAGO,  
28 PARK PLACE 710 BETZ BLD'G. 160 CONGRESS ST. 204 MASONIC TEMPLE  
TO 21 BARCLAY ST. FACTORIES AND OFFICES, MERIDEN, CONN.

# THE BOWDEN SEAMLESS RING

IS MADE ONLY BY

## J. B. BOWDEN & Co.,

Makers of Finger Rings of every Description.

REMOVED FROM BROADWAY AND JOHN STREET,

TO 3 MAIDEN LANE,

NEW YORK.

## TOWLE MFG. Co.,

Silversmiths.



OLD ENGLISH BUTTER SPREADER.

FACTORIES:

NEWBURYPORT,

MASS.

CHICAGO OFFICE, 149-151 STATE ST.

## LATEST STYLES

.. IN ..

## FINE JEWELRY.

GOLD BUCKLES,  
CZARINAS,  
HAIR PINS,  
BACK AND  
SIDE COMBS.

John A. Riley & Sloan Co.,

Broadway and 17th Street,

NEW YORK.

ESTABLISHED 1870.



TRADE MARK.

## SAMUEL C. JACKSON,

MANUFACTURER OF

FINE CASES FOR

Jewelry, Silverware, &c., also Hardwood  
Chests, Trays, and Sample Cases.

180 BROADWAY,

NEW YORK.

### "SECURITY PIN GUARD."

Can be Used on Scarf or Ladies' Pin.

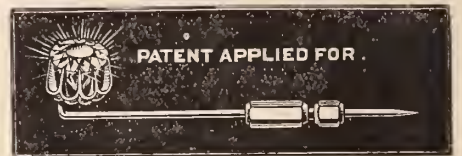

PATENT APPLIED FOR

85c. Dozen Gold, \$6.00 } Doz  
Net Cash. Silver, 3.00 } Net Cash

DISCOUNT TO JOBBERS.

Security Mfg. Co., 7 Astor House, B'way, N.Y

FERD. FUCHS & BROS.

## SILVERSMITHS,

MAKERS OF STERLING SILVERWARE,

808-810 Greenwich St., New York.



# WALTHAM

## 18-Size, 17 Jeweled

### Hunting or Open Face.

Center Pinion Jeweled in both Upper and Lower Plates.

CRESCENT STREET, Nickel.

APPLETON, TRACY & CO., Nickel.

APPLETON, TRACY & CO., Gilt Damaskeened.

No. 35 Nickel.

No. 25 Gilt, Damaskeened.

The manufacture of the above grades has been discontinued. The limited number on hand and in process are being refinished, ornamented and Center Jeweled in both Upper and Lower Plates, making them 17 Jeweled.

THEY ARE ENGRAVED "17 JEWELS."

No more of these movements will be obtainable after the present quantity is exhausted.

The advantages of Center Jewel in Lower as well as Upper Plate will be evident to all watchmakers.

SUPPLIED BY JOBBERS IN AMERICAN WATCHES.

# ADVERTISING HINTS FOR RETAIL JEWELERS.

BY CHARLES AUSTIN BATES.

The Editor of THE JEWELERS' CIRCULAR has asked me to contribute a series of articles on retail jewelry advertising.

It is my desire to make these articles as useful as possible and to that end, an invitation is extended to retailers to send to me any of their advertisements which they would like to have criticised. It may be that there are some questions which they will care to ask and that I can answer.

Each week I will give several examples of advertising, which will illustrate my ideas on the subject. I do not present these advertisements with the claim that they are perfect, but only with the hope that they will contain some useful suggestion, and that some dealer at least will find that by making slight changes in them, as local conditions require, they will be able to make use of them, and so relieve themselves of one detail of their business.

## PART IV.

**N**UMEROUS complimentary letters have come to me since the appearance of the first of my "hints." It is always gratifying to know that one is being useful, but it is more useful sometimes to be criticised. If I am able to give helpful hints I shall be glad to know it, and the more matter I receive for criticism the better I shall be pleased.

\*\*

Holiday time is coming right along. It is the time of all others when a jewelry stock offers opportunities for attractive advertising. The stock fairly bristles with advertising opportunities. It may be a little too soon to talk much about the holidays, but their approach should be borne in mind.

Advertisements should be suggestive of presents. Each ad. ought to deal with one thing and incidentally might be given a hint that it would make an acceptable gift for somebody.

\*\*

I notice in the New York Sun the advertisement of Lambert Bros. It is the same old tiresome story. It says: "Exclusive designs and largest assortment in diamonds, gold and silver jewelry, expressly manufactured and particularly appropriate for the coming holidays."

The space taken to make this astonishing statement is nearly an inch, and costs three or four dollars. Lambert Bros. might just as well have saved that much. The sentence quoted doesn't carry conviction with it. It is so general in character as to lose effectiveness. It is like a charge of bird shot. It scatters over too much surface and is too light to make any impression on the minds it strikes. Put one clear, clean solid shot about scarf pins, or diamond rings, or any other one thing, into the same space and it would hit somebody with sufficient force to make a buyer. It will do to add in a single line: "Holiday stock in —. Suggestions in plenty for pretty presents."

Mention holidays and presents incidentally, but in each advertisement try to sell some one thing. Try to make people see just how good it is, how artistic, how desirable and how reasonable in price.

Give exact and definite information about it. Talk about it just as if the reader were in the store. Get out of the old stereotyped

style. Don't be too dignified, but don't be flippant either. Talk business.

\*\*

This is a somewhat catchy idea for an advertisement from Providence R. I.:

**Welcome !**  
 Woman  
 Wife  
 Widow  
 Widower,  
 Why  
 Worry  
 Wonder  
 Wait  
 When  
**WHITTIER**  
 Willingly  
 Warrants  
 Worthy  
**WATCHES**  
 Which  
 Will  
**WEAR**  
 Wonderfully  
**WELL.**

All the latest novelties in jewelry and silverware.  
**No. 327 Westminster Street.**

The jewelry houses of Detroit are particularly good advertisers. I don't know of

**EBONY**  
 AND  
**SILVER** In Combination.

We have placed in stock to-day a complete line of Toilet Goods in Solid Ebony and Sterling Silver.

This new creation in Toilet Goods will recommend itself to those wishing to purchase something novel and beautiful.

The combination of wood and silver makes a very pleasing effect and gives promise of being more than simply a fad.

—:0:—

**WRIGHT, KAY & CO.,**  
 JEWELERS AND IMPORTERS,  
 140 and 142 WOODWARD AVE.

another city in which the jewelry ads. are so good. Those of Wright, Kay & Co. are probably better than any of the others. The typographical effect is always neat and clean, the display excellent, and the matter handled in a very pleasing way. I haven't seen any of their advertisements recently, but I reproduce an old one, which will serve to show the general style of all of them.

Here is another Detroit ad. that is very well displayed in a distinctly different style:

**A**  
**DOLLAR**  
**AN OUNCE.**

We begin to-day the sale of Sterling Silverware at the unheard of low price of One Dollar an Ounce. This brings Tea Spoons—say six ounces weight—at only \$6 a dozen. All other ware in the same proportion—One Dollar an Ounce.

Our stock is very complete in standard goods—Finest designs, staple patterns, best makers.

We've enough for everybody.

**F. ROLSHOVEN & CO.,**  
 ESTABLISHED 1855.  
**166 WOODWARD AVE.**

The one fault that I have to find with it, is that it doesn't tell how cheap silver is at \$1 an ounce. In spite of all the recent agitation about silver money and "ratios," and all that sort of thing, I believe there are really very few people who know what an ounce of silver means in money, or in spoons. Otherwise the advertisement is a good one.

## Louisville.

A jewelry auction store has been opened on Jefferson St., near Fourth Ave.

Moulenix, the auctioneer, who ran the jewelry auction on 4th St., has discontinued.

Geo. Boergershausen will commence an auction sale Nov. 1st.

Geo. Wolf & Co. have made extensive improvements in their store, and have had new paper hung on the walls.

Leonard Huber was thrown from his bicycle on the corner of Brook and Oak Sts. His knee cap was fractured and he was badly bruised. Mr. Huber will be laid up for some time.

Victor M. Lorch, the Market St. jeweler, has made extensive alterations in the front of his store. One of the entrances has been closed and the space thus obtained was utilized by the enlargement of the show windows. The front has been painted and a great improvement is noticeable.

**Joe Schwartz, the Diamond Colorer, Again in Evidence.**

The fact that a new jewelry concern known as John C. Ashton & Co. was recently opened at 9 S. 4th St., St. Louis, Mo., was made apparent to the New York trade last week by the orders for samples which several diamond importers and jewelry manufacturers received. In their orders, Ashton & Co. gave as reference J. Otis Stevens, whom they said was a banker at 200 N. 2d St., St. Louis.

Unfortunately for the would-be purchasers, none of the firms from whom they ordered could get satisfactory answers to the inquiries made to the mercantile agencies in reference to the financial condition of either Ashton & Co. or their banker. In fact neither was known at all. Among others who received orders but who did not fill them were Aikin, Lambert & Co., Oppenheimer Bros. & Veith and Alois Kohn & Co.

The order received by Kohn & Co. was for a dozen samples of 10 and 14 karat chains. On sending an inquiry to Bradstreet's they received word that not alone were Ashton & Co. not known but their reference appeared questionable. From another firm, prominent importers of diamonds, a CIRCULAR reporter was told that after receiving a similar order they telegraphed to their representative then in St. Louis to investigate, and he reported that Ashton & Co. were none other than Joe Schwartz, known for his painted diamond swindles and other notorious operations in the jewelry trade.

Their representative, said a member of this firm, was one who could be relied upon, and they had no doubt that Schwartz was again at work using as a cloak the name

of John C. Ashton & Co. Mr. Ashton is believed to have gone to St. Louis from Chicago. He was employed, it is said, by O. C. Sinclair, an instalment watch dealer.

**The Death of Hon. George H. Shearer.**

BAY CITY, Mich., Oct. 25.—The death occurred a few days ago of the Hon. Geo. H. Shearer, one of the oldest and most respected residents of Bay City, after an illness of two weeks.

Deceased was born in Albany, N. Y., July 9, 1825, and in 1845 removed to Detroit, where he operated a sash factory. Subsequently he sold out and engaged with his brother, the Hon. James Shearer, in the contracting business. In 1863 he came to Bay City, and engaged in the manufacture of lumber. Later he became a manufacturer of flour, remaining in that business until 1888. He then began traveling. In November, 1889, he started a jewelry store.

**A Brace of Professional Burglars Captured by One Policeman.**

CHICAGO, Ill., Oct. 27.—An officer passing through the alley in the rear of Jos. P. Wathier Co.'s jewelry store, 178 W. Madison St., surprised and captured two burglars in their efforts to pry open the rear door of the store. He was attracted by the noise of cracking wood. The door was protected by an electric system, but the thieves had not proceeded far enough when caught to ring the alarm.

They are professional thieves, who had been attracted by Mr. Wathier's handsome show window and well filled cases, but were seemingly ignorant of the electric protective system. Their names are Thos. Moran, alias Burns, and Mike Brennan.

**Last Week's Arrivals.**

*THE CIRCULAR has perfected arrangements for obtaining the names and hotel addresses of all the latest buyers visiting New York, and each day posts in its office, 189 Broadway, a bulletin which every member of the trade is cordially invited to copy.*

The following out-of-town dealers were registered in New York during the past week: J. S. MacDonald, Baltimore, Md., Imperial H.; Mrs. J. C. Nourse, Woodward & Lathrop, Washington, D. C., St. Denis H.; M. Freudenheim, Elmira, N. Y., Astor H.; A. L. Bearer, Boston, Mass., Murray Hill H.; H. C. Kachlein, Lafayette, Ind., Belvidere H.; A. Gennett, Binghamton, N. Y., Astor H.; L. S. Lowenthal, Bradford, Pa., Union Square H.; S. Lesser, Syracuse, N. Y., Imperial H.; O. Young, Chicago, Ill., Holland H.; J. T. Ellis, Toronto, Ont., Murray Hill H.; A. S. Goodman, Philadelphia, Pa., St. Cloud H.; M. Kohler, Hagerstown, Md., Sinclair H.; H. Schneider, Buffalo, N. Y., Morton H.; G. W. Fairchild, Bridgeport, Conn., Grand Union H.; E. Scheuer, Toronto, Ont., Astor H.; E. Zahm, Lancaster, Pa., Metropolitan H.; A. M. Field, Asheville, N. C., Imperial H.; T. A. Scott, Cadiz, O., Broadway Central H.; L. Emery, Jr., Bradford, Pa., Imperial H.; A. Anderson, Detroit, Mich., Astor H.; C. T. Anderson, Reading, Pa., Astor H.; F. S. Myers, Elmira, N. Y., Continental H.; M. Roseman, Elmira, N. Y., Union Square H.; J. A. Becker, for J. G. Myers, Albany, N. Y., Oriental H.; C. A. Potter, Houghton & Dutton, Boston, Mass., Murray Hill H.; M. S. Liberman, Syracuse, N. Y., Astor H.; H. Kohn, Hartford, Conn, Broadway Central H.

# INFORMATION



1070. MUCILAGE POT.

MAKERS OF HIGH GRADE AND ARTISTIC

## Bachrach & Freedman, STERLING SILVER WARES,

SAN FRANCISCO: 230 KEARNEY ST.

CHICAGO: 806 MASONIC TEMPLE.

1 & 3 UNION SQUARE, NEW YORK.

WRITE FOR ILLUSTRATED CATALOGUE OF NOVELTIES.



DE MARK



# The Jewelers' Circular

AND  
HOROLOGICAL REVIEW.

PUBLISHED EVERY WEDNESDAY BY

THE JEWELERS' CIRCULAR PUB'G CO.,

189 BROADWAY, NEW YORK CITY.

A JOURNAL DEVOTED TO THE INTERESTS OF JEWELERS, WATCHMAKERS, SILVERSMITHS. ELECTRO-PLATE MANUFACTURERS, AND ALL ENGAGED IN KINDRED BRANCHES OF INDUSTRY.

Our Editorial columns will contain our own opinions only, and we shall present in other columns only what we consider of interest or value to our readers. Advertising matter will not be printed as news.

Advertising rates in THE CIRCULAR are lower, considering the number of tradesmen reached by its large circulation, than in any other jewelry journal.

Notices of changes in standing advertisements must be received one week in advance; new matter can be received up to Monday.

## INFORMATION FOR SUBSCRIBERS

### Terms of Subscription, Postage Prepaid.

	PER ANNUM
United States and Canada, - - -	\$2.00
Foreign Countries in Postal Union, -	4.00
Single Copies, - - - - -	.10

New subscribers can commence at any time.

Payments for THE CIRCULAR, when sent by mail, should be made in a Post-Office Money Order, Bank Check or Draft, or an Express Money Order or Registered Letter. All postmasters are required to register letters whenever requested to do so.

Pay money only to authorized collectors having proper credentials.

Returning your paper will not enable us to discontinue it, as we cannot find your name on our books unless your address is given.

In changing address always give the old as well as new one. Your name cannot be found on our books unless this is done.

We will continue to send papers until there is a specific order to stop. In connection with which all arrearages must be paid; but such an order can be given at any time, to take effect at the expiration of the subscription. All such orders will be promptly acknowledged by mail.

The Courts have decided that all subscribers to journals are responsible until arrearages are paid in full and an order to discontinue has been received by the publisher.

Member of the American Trade Press Association

VOL. XXIX. Oct. 31, 1894. No. 14.

## The Extension of the Diamond Cutting Industry in America.

NO movement that has transpired in the jewelry trade of America has possessed greater significance than the extension of the diamond cutting industry which marks the present day. The increase in the tariff duty on cut diamonds from 10 per cent. to 25 per cent. has had an effect not calculated upon by our legislators in Washington, in stimulating on our shores this industry of cutting; we say not calculated upon, for it is the principle of protection that is at work, and it was the object of the Democratic Congress to destroy the operation of this principle as far as the United States is concerned. Though there were until comparatively recent days a few cutters in New York, Boston and Chicago who managed to make a livelihood, it is Stern Bros. & Co., New York, to whom the honor is due of having proved that the industry could be carried on

in America upon an extended scale. Since the inception of their experiment and its successful fruition, we have witnessed the removal from Amsterdam to Brooklyn of the large plant of Zilver Bros., the erection of other extensive plants by Sanders, Bruhl & Co. in Newark, by Arnstein Bros. & Co. and John N. Disselkoe in New York, while we learn that L. Tannenbaum & Co., New York, are projecting a factory, and that preparations are going forward for the removal of the establishment of George Kryn from Holland to this country. When these establishments alone are in activity, the diamond cutting industry of America will give employment to fully 700 operatives. These factories are fitted with machinery and appliances that combine all the improvements conceived up to the present time and it is proposed by the American cutters to give their Dutch confrères a few lessons in their craft. The dealers of cut diamonds and precious stones, we understand, do not consider their interests adversely affected by this extension of cutting by Americans, as the advantages of New York being a diamond center, such as London and Amsterdam have been, are manifold. Notwithstanding the aggressive attitude assumed by the De Beers Consolidated Mines Co., in reference to the American tariff, this corporation cannot overlook the importance of this country as a consumer of diamonds, and we do not doubt that if the exigencies of the case required that their market be transferred from London to New York, they would eventually fall in line. Cecil Rhodes has already weakened in his position, and is now arguing reciprocity, and lamenting the £10,000 voted by the shareholders of the company for an exhibit of diamonds in America. The permanent planting in America of an industry like diamond cutting will be desired by all broad minded persons, though it may in the initiative stage result in the immigration of foreign mechanics. Foreign labor, as far as diamond cutting is concerned does not compete with native labor, as the latter has necessarily been limited; and in the future, if the industry obtains a permanent footing, to which all signs point at present, these foreign workmen will give place to their American sons, and these again to their sons. It to be hoped, if the increased tariff on precious stones does not cause the industry generally to suffer through the operation of smugglers, regarding which it is too early to fully judge, that our National legislators will leave good alone.

**A Decision Relating to the Memorandum Principle.** THE decision of Judge McAdam, of the New York Superior Court, in the case of E. B. La Fetra, assignee of Charles Seale & Co., against William A. Glover, pawnbroker, bears pertinently upon the memorandum principle of business employed by jewelers. It is as follows:

## TO THE JEWELRY TRADE:

*THE JEWELERS' CIRCULAR has concluded its series of Four Special Fall Editions. With due appreciation of the sentiment of modesty, we cannot but feel that this series has proved eminently successful, the spontaneous and plenteous patronage from advertisers being evidence sufficient in support of this statement.*

*We have been applauded in our efforts by many advertisers who have considered their investment a profitable one; and it is with their satisfaction in view, that we consider the publication of a*

## Special Holiday Number

*to be issued at a propitious time in November, but a proper and essential supplement of these Special Fall Editions.*

*This HOLIDAY NUMBER will be a work of as high artistic and literary merit, as a liberal and ambitious policy insures.*

### THE JEWELERS' CIRCULAR PUB. CO.

That "no one can transfer to another a better title than he has himself, is a maxim," says Chancellor Kent, "alike of the common and civil law, and a sale *ex vi termini* imports nothing more than that the *bona fide* purchaser succeeds to the rights of the vendor."

In this case the jury, by their verdict, found that Seale & Co., the owners of the diamond pin, did not sell it to the Baroness Blanc, but loaned it to her, with the liberty of purchasing same on payment of a stated price. She never availed herself of the privilege of buying, never did buy, and the pin remained the property of Seale & Co. until it was transferred by their general assignment to the plaintiff.

The baroness had no title whatever to the property, and could not, therefore, convey or pledge it; and the fact that the defendant in good faith advanced \$800 upon the pin gives him no greater right than the baroness herself had. The latter had a mere naked possession; this has never been held to confer a power of disposition; and an unauthorized sale, although for a valuable consideration, and to one having no notice that another is the true owner, vests no title in the vendee (see authorities collated in *Smith v. Clews*, 114 N. Y., 190; *Heilbronn v. McAleenan*, 16 St. Rep., 957; *Anderson v. McAleenan*, 29 St. Rep., 406.)

Plaintiff's assignors never furnished the defendant with any *indicia* of title; nor have they or he been stopped in any way from asserting title.

Though the goods were charged to the baroness, it was proved that the entries were made without instructions from the principals, who testified that they would not have sold on credit to a stranger, without security, such goods as diamond ornaments. The jury evidently weighed these considerations in reaching a result. They found for plaintiff for the possession of the property, assessing its value at \$1,409.70.

The defendant, being a pledgee, was not "a subsequent purchaser or mortgagee" within the meaning of the act of 1884 ch. 315, in reference to the filing of conditional sale agreements; he was, therefore, entitled to no benefit thereunder.

The evidence sufficiently sustains the verdict, and, for the reasons stated, the motion for a new trial must be denied.

### New York Notes.

A judgment against Jno. B. Garcia for \$222.73 has been entered by C. Parker.

L. & M. Kahn & Co. have entered a judgment for \$487.82 against Louis Hein.

Louis Strasburger returned from Europe on *La Bretagne*, which arrived Sunday.

A judgment for \$1,523.05 has been entered against Elias M. Pilzer in favor of M. Weil.

Wightman & Hough Co. have entered a judgment for \$103.17 against Henry Carter.

A judgment against Edmund Heinecke for \$42.94 has been entered in favor of J. Rottkamp.

Isaac Gordon, 113 Eighth Ave., has given a bill of sale of jewelry fixtures to D. I. Lieffer for \$430.

Edward B. La Petra, assignee of Chas. Seale, has filed a judgment for \$1,663.78 against Wm. A. Glover.

Myer Saltzstein, 79 East Broadway, has renewed a chattel mortgage on office fixtures to A. Kohn & Co.

The Fahys Watch Case Co. have satisfied the judgment for \$7,894.38 entered July 30, 1894, by Horace G. Skidmore.

Judgments against Mordecai S. Kaufman, were entered Friday by A. Johnston for \$332.96 and by R. J. Elwood for \$448.32.

Wm. Schroeter, 198 Grand St., has given to Wm. H. Schroeter, a bill of sale of jewelry fixtures. The consideration is \$1,200.

At a special meeting of the New York Jewelers' Board of Trade, Oct. 23, Follmer, Clogg & Co. and Jos. H. Fink & Co. were elected to membership.

Judgments against Jno. B. Garcia have been entered by C. Parker for \$87.87, \$163.64 and \$233.89, by H. G. Fisk and others for \$166.03, and by Am. Net & Twine Co. for \$234.45.

E. H. Proudman, 42 Maiden Lane, has brought an action in this city against David Wolff, formerly of Auburn, N. Y., to recover \$99.70 and interest, the amount due on goods sold in 1889.

Reymond & Gottlob, proprietors of the New York Pure Aluminum Co., dealers in aluminum fancy goods, jewelry, tableware, etc., 830 Broadway, Wednesday opened a down-town branch store, at 18 Maiden Lane.

In the Supreme Court before Judge Beach Friday, Cammerden & Forster obtained a verdict for \$1,022.50 against Albert H. Moore, the value with interest of an article which Moore agreed to purchase from the plaintiffs. Moore denied the agreement.

Louis Jagielky, diamond setter, 176 Broadway, and Jno. P. Gantler, manufacturer of diamond jewelry, 8 John St., have consolidated their interests, and from Nov. 1st will carry on business at 176 Broadway under the firm name of Jagielky & Gantler.

Tiffany & Co. have placed on exhibition for a limited period the Zschille collection, consisting of several thousand pieces of antique armor, weapons, knives, forks, spoons, and various implements of steel and other metals. The collection is believed to be the largest and most comprehensive of its kind in existence.

Braverman & Bostleman, San Francisco, Cal., deny the report published in a contemporary last week that they have discontinued their New York office at 16 John St., R. F. J. Bostleman, father of one of the partners, who is in charge of the New York office, stated that he could not imagine how the report originated.

Numbers of people congregated in City Hall Park Monday afternoon to watch a workman remove the south face of the City Hall tower clock, which was cracked during a storm six months ago. The Seth Thomas Clock Co. put in the new dial which is of glass, six feet inches in diameter, and three-eighths of an inch thick. The figures are over a foot long.

Justice Cullen, in the Queens County Supreme Court, Long Island City, last week dismissed the suit of Mrs. Susie Pettit, to obtain an absolute divorce from her husband, Theodore Pettit, a jeweler of Inwood. Mrs. Pettit alleged various irregularities on the part of her husband, but Justice Cullen threw the action out of court because of a lack of evidence.

Judge Barrett, in the Supreme Court, Friday, heard the reargument of the motion to place on the short cause calendar for trial on Oct. 26th, one of the three actions of Horace Craighead against the Craighead & Kintz Co. The suit is to recover \$2,311.95 on two promissory notes against which the defendants set up a counterclaim. Judge Barrett denied the motion with \$10 costs to the defendant.

Martin Marcus, whose funeral was held from his late residence, 161 E. 63d St., Oct. 23d, was at one time a prominent figure in the jewelry trade. Among other firms he was connected with was the International Jewelry Co. which he established many years ago. Of late years he had been a commission merchant. Mr. Marcus was born in Hamburg, Germany, 50 years ago. His widow survives him.

Oscar Newman has succeeded to the plating and coloring business of his father, the late Louis Newman, who died at his residence 840 Halsey St., Brooklyn, Oct. 17. Mr. Newman who was born in Darmstadt, Germany, was 75 years old, and was known as one of the pioneer platers of the trade. Oscar Newman continues his father's business at the old address, 79 Nassau St., where it has been for nearly 30 years.

L. Tannenbaum & Co., 52 Nassau St., have decided to establish a diamond cutting and polishing plant and will shortly start cutting diamonds on a large scale. Lippman Tannenbaum stated Monday that though the location of the factory had not yet been definitely decided upon, it would be

started within a very short time. The firm have already purchased a large quantity of rough diamonds in anticipation of their venture.

Phillip Cohen, a merchant tailor, was a prisoner in the Tombs last week awaiting requisition to Philadelphia on the charge of grand larceny. The complainant is A. L. Millard, jeweler, 713 Sansom St., Philadelphia. Cohen, on Oct. 15th, said he wished to make his wife a birthday present and had the jeweler send to his place of business two pairs of diamond earrings which he promised to return the next day. Cohen failed to account for the gems. The police traced him to this city and arrested him at 174 Anthony St. Cohen admitted his guilt and told where the stolen jewelry was pawned.

### Chas. F. Wood & Co. Obtain a Judgment Against a Guarantee Co.

In the United States Circuit Court, Friday, before Judge Wallace and a jury, Charles F. Wood & Co., importers of diamonds, 14 Maiden Lane, New York, recovered a verdict against the Mercantile Credit Guarantee Co., of New York, for \$5,297. The action was brought by the firm upon a policy of insurance issued to them by the company in the early part of 1893, to recover the amount of certain losses incurred by the firm in that year.

The policy provided in the usual form that the insured should bear a certain initial loss, and also that the amount of a bond of indemnity held by the firm in the American Credit Indemnity Co., of New York, for \$10,000 should first be deducted, after which the policy of the Mercantile Credit Guarantee Co., of New York, was to become available. The latter company denied their liability for any substantial payment under their own construction of their policy.

The facts in the case were substantially undisputed. The defendant company's attorneys, A. J. Dittenhoefer and David Murray, however, claimed that the word "loss" throughout its policy referred to the limit of credit. For example, that the 30 per cent. individual limit of loss on debtors of a certain capital rating signified that the credit extended to any such debtor was limited to the amount of 30 per cent. of its lowest capital rating, and that where the debtor made a settlement, the company were entitled to be allowed a proportionate share of all amounts paid by the debtor.

The plaintiffs, through their attorneys, Albert Stickney and F. L. Crawford, maintained that the word "loss" in the policy had no reference to a limit of credit, but meant actual net loss after deducting all amounts received from the debtor, and that the company were not entitled to any allowance. The latter view was adopted by Judge Wallace and accordingly a verdict was directed for plaintiffs.

## Providence.

### BUSINESS CONDITIONS.

As a sure sign that the jewelry business is enjoying a healthy revival rather than a boom, is the fact that during the past few weeks the increase has been gradual until now most of the manufactories are running on full time, with a full complement of men, while some are obliged to work nights. In some lines, of course, the busy season does not open until later, but among novelty and general makers, everything seems to be humming. In one large shop 225 hands are busy at work, being an increase of 25 over the usual complement. In several of the smaller shops the help is being gradually increased and the prospects for a good Winter trade are said to be considerably better than for three years.

The styles in staple goods remain practically the same as last year. The exception to be noted is in chains. For women the old style guard chain to be worn about the neck is in vogue, and the greatest demand in men's chains is for large links and heavy seals. Plain gold band rings will be worn by both sexes more than usual perhaps, and the cane scarf and stick pins are to be exceedingly popular, judging from the large orders that have already been received for this latest novelty.

The most radical changes in the silver workers' novelties are few, but of an agreeable nature. The latest novelty is an orange peeler which will be appreciated by the

bashful and awkward who hesitate about eating an orange in company. In general design this peeler resembles a lady's shoe hook, except that the hook end is more like a large crochet hook with sharp edges to make incisions in the peel which is pulled off by the hook as neatly as you please. Silver buckles for belts of new and pretty design are being turned out in large quantities and tortoise shell side combs, silver mounted, are also very popular.

Schrelver & Fraser is the style of a new manufacturing concern who have commenced business at 109 Friendship St.

T. G. Frothingham & Co. have removed from North Attleboro, Mass., to the fourth floor of the Fitzgerald building, Eddy St., this city.

Foster & Bailey, S. & B. Lederer, and the Waite, Thresher Co. were among the firms that have been advertising for help the past week.

Howard Sterling Co. have been at work for some time upon the elegant silver trophy cup which was offered last June by the Country Club to the winner of an Agawam Hunt steeplechase.

Kent & Stanley Co. are having an electric plant put into their new building, corner of Aborn, Beverly, Sabin and Mason Sts., by the Western Traction Co., St. Louis. Plans have been made for the running of upward of 3,200 incandescent lights throughout the building.

At the 25th anniversary of Haggai Lodge, No. 132, Independent order of B'nai B'rith, last Monday evening at Music Hall, David Bernkopf was treasurer of the committee of arrangements and L. Dimond, David Frank, Benjamin Lederer and Sigmund Lederer were among the members of the various committees.

The entire plant and good will of the extensive manufacturing jewelry concern of the late firm of G. D. Willis & Co., 62 Page St., were sold at public auction at noon, 25th inst., by auctioneer Henry F. Ferrin, for the nominal sum of \$150. There were only about half-a-dozen gentlemen present and the business was bid in in a lump for the benefit of Ansel L. Sweet, one of the partners, by his son-in-law, Martin L. Grout. The sale was merely a formality for the purpose of legalizing the dissolution of the firm, owing to the mysterious disappearance of Mr. Willis in August last, as detailed at the time in THE CIRCULAR. From the time that he mailed his letter from Philadelphia, bearing date of Aug. 11, in which he stated that he was going upon a sea voyage, until the present nothing has been heard of the missing man.

Judge Harlan, in Baltimore, Md., decided that Peter H. Keelan, one of the men accused of robbing S. Kirk & Son, an account of whose trial is detailed in another part of this issue, was guilty of larceny. Sentence was suspended.

## THE INCREASED DUTY ON

# DIAMONDS

 HAS NOT INCREASED OUR PRICES.

Mr. L. Tannenbaum on his last trip having purchased and bought over under the old duty over five times his usual quantity of the finest Diamonds, Rubies, Sapphires, Emeralds, Opals, Pearls, and other Precious Stones and Melles, he will continue to sell to the trade for the next six months, at prices governed by the old rate of 10 per cent. being thus a clear gain of

 15 PER CENT. 

to dealers who place orders NOW.

This is an Opportunity of a Lifetime. These Goods are the Finest and Cheapest in the Market To-Day.

**L. TANNENBAUM & Co.,**  
 Importers and Cutters of Diamonds and Precious Stones,  
 COR. MAIDEN LANE & NASSAU ST., NEW YORK.

**The Attleboros.**

A late mail delivery to the shops is one of the Attleboro post office improvements. This has been petitioned for for years.

H. E. Cobb, of Attleboro, made what may be termed a record-breaking trip. In five days, two weeks ago, he visited his patrons in Des Moines, Omaha, Lincoln, Denver, Kansas City and St. Louis.

J. T. Ryan, who was at one time in business and has of late been with Watson, Newell & Co., died last week from injuries received in being thrown from a team in Pawtucket. He was 51 years of age.

Some night recently the Summer cottages of J. E. Tweedy, L. E. Morse, W. H. Fisher and William Smith were burglarized and considerable silverware taken. The cottages are at Lake Pearl, Wrentham.

Bell & Cobb on Oct. 24, dissolved partnership by mutual consent. William H. Bell is authorized to collect the accounts and pay all bills. The business will be continued by William H. Bell under the firm name of W. H. Bell & Co.

Chas. Cogswell, several years employed by G. W. Cheever & Co., Wednesday afternoon killed his wife and then committed suicide. Jealousy was the cause. Cogswell was noted as an expert and faithful worker, and was a prominent Odd Fellow. The bodies were found in the road late at night.

Attleborians evidently believe in getting ready for the 300th anniversary of the town as soon as possible. A popular subscription has been started for funds for the tri-centennial to be observed Oct. 18, 1994, and

already over \$400 has been subscribed, the conditions being that the names of those who have and will subscribe shall be printed on the official program one century from now. The promoter of this fund says it ought to amount to \$20,000 when needed.

The wedding of John E. Tweedy and Miss Maud Fisher, which took place Wednesday evening, was the society event of the year in the Attleboros. Mr. Tweedy is a member of the firm of E. Ira Richards & Co. and a grandson of late E. I. Richards. Miss Fisher is a daughter of Clarence Fisher, of E. I. Franklin & Co. The ceremony was in the Universalist Church, which was decorated from chancel rail to the doors. There were many guests from New York, Brooklyn, Boston, Providence and Chicago. The ushers were: C. Ray Randall, Louis E. Morse, William H. Pond and J. R. Gleason, Jr. The reception which followed at the Fisher homestead, was a brilliant affair. Mr. and Mrs. Tweedy will reside at the Richards mansion on Elm St.

**Connecticut.**

New hands are being employed every day now at the Thomaston watch factory.

Charles Casper, ex-president of the Meriden Silver Plate Co., was visiting in Meriden Tuesday last.

The factory of the Wm. L. Gilbert Clock Co., Winsted, is running until 8.30 o'clock every evening except Saturday.

C. H. Tibbits, of Wallingford, was elected a director of the First National Bank there, Oct. 24, vice Gurdon W. Hull, deceased.

G. G. Tibbals is home, in Meriden, from an extended tour through the west in the interests of Meriden Britannia Co. Mr. Tibbals reports things as on the improve in the west.

Howard Wadsworth, of the Winsted Optical Co., West Winsted, was married in Springfield, Mass., a few days ago, the bride being a Miss Lewis, of that city.

Deacon William B. Crampton and wife, of Madison, celebrated their golden wedding Tuesday last. Mr. Crampton is an eyeglass and spectacle case manufacturer.

James J. Grace and Mrs. R. E. Pomroy were married at the home of the bride, in Hartford, recently. Mr. Grace, for 26 years has been in the employ of David Mayer, the Hartford diamond merchant.

Henry L. Hart, for many years a trusted employe of the Wm. Rogers Mfg. Co., Hartford, was married recently to Miss Jessie G. Robertson, of that city. The wedding presents included a set of silver ware from President Watrous, of the Rogers Co., and a silver ice pitcher and a tea set from Mr. Hart's fellow employes.

The A. Gluck Jewelry Co., Dodge City, Kan., have incorporated with a capital of \$3,500. The directors are as follows: A. Gluck, Leo Gluck, Manta Gluck, Louis Loebner and Max Gluck.

Constable Doran, of South Bethlehem, Pa., last week received word that C. Lewis is suspected of having robbed Storm's jewelry store, in South Bethlehem, of seven silver watches about two weeks ago. Mr. Storm was having a public sale of his goods about that time.

The Weber Co., Milwaukee, Wis., have assigned to Thomas H. Brown who qualified in the sum of \$5,000. The company were incorporated under Wisconsin laws and had headquarters with O. L. Rosenkrans & Thatcher Co., Milwaukee, but carried no stock there. This concern is not the Weber Jewelry Co., of the same city.

**Paul Jeanne,** EIGHTEENTH STREET and 4<sup>TH</sup> AVE. N. Y.  
 (Bradley Building.)  
 MANUFACTURER OF  
 FINE DIAMOND JEWELRY.

**OPPENHEIMER BROS. & VEITH,**

OFFER TO THE TRADE

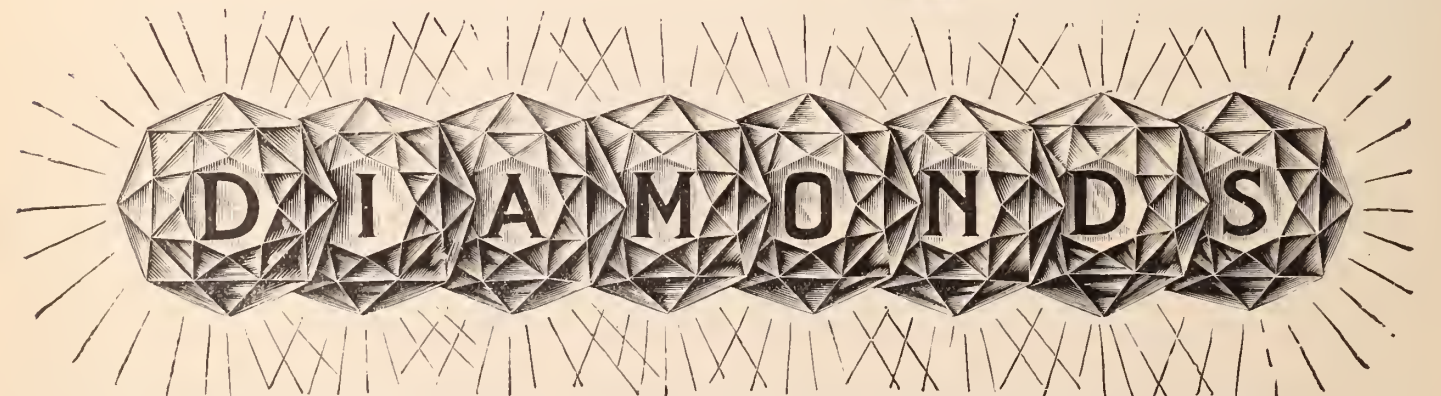

Cut by them according to scientific principles, at prices far below imported goods of the same quality.

NEW YORK, 35 MAIDEN LANE.

Amsterdam, 2 Tulpstraat.

London, Eng., 27 Holborn Viaduct.

### Pittsburgh.

J. C. Grogan has returned from an eastern trip.

W. H. Milchsack has rented half of his store on Fifth Ave.

J. Harvey Wattles has returned home from a month's trip abroad.

George L. West, of West, White & Hartman, is doing Ohio this week.

Max Arnheim has returned from a ten days' wedding trip through the eastern cities.

C. H. Weinhaus is in Chicago. J. Grafner is going east this week to buy holiday goods.

Goddard, Hill & Co. have issued an action on execution against Leopold Weil & Co., on Smithfield St.

Otto Heeren seriously injured his knee cap one day last week and has been laid up in consequence.

C. Hauch has lately added an electric plant to his store and has entered the manufacturing business.

B. Neville, Dawson, Pa.; J. W. Caler, Beaver, Pa.; and D. L. Cleeland, Butler, Pa., were here last week.

E. P. Roberts & Sons have been improving their art department. Steele Roberts has returned from his eastern trip.

Mrs. Hauch, mother of Chris. Hauch, died last week. Mr. and Mrs. Hauch recently celebrated their diamond wedding.

Russell Roddy, of Allegheny, who lately removed to new quarters, has been re-decorating and fixing up his store with new cases.

Alex. Fleming, the McKeesport jeweler, has removed to Fifth Ave., McKeesport, and pronounces the move to be for the better.

J. Arnheim & Son, Allegheny, have closed out their Ohio St. store, and have combined with 97 Federal St., and have taken up their residence in the same place.

Herman Heeren, brother of Otto and William Heeren, is now book-keeper for the firm. George Ruhl, lately with S. T. Little, has also been engaged.

Heckel, Bieler & Co. have been negotiating with their creditors for a settlement and it is likely that the firm will soon have their affairs in working order.

Weisser Bros., 1519 Penn. Ave., have dissolved partnership, A. H. Weisser continuing, while John Weisser will enter into other business. J. O. Slemmons and P. Bauman appraised the stock at \$4,500.

O. C. Lane, of Reed & Barton, reported to the Pittsburgh correspondent of THE CIRCULAR that his firm's factory is running 16 hours a day. Mr. Lane remained five days in Pittsburgh and reports a wonderful increase of trade there.

### Philadelphia.

John F. Brounley, formerly with P. F. Klemmer, has opened a retail store at 1530 S. 2d St.

The Fox Optical Co. have increased their facilities by the addition of a new building in the rear.

I. Bedichimer is preparing to move into his new quarters at the S. E. corner of 11th and Sansom Sts.

Miss Augusta Fichtel, daughter of Charles Fichtel, jeweler, was married to Dr. H. Baxter on the 17th inst.

J. Kennedy, formerly of 2d and Vine Sts., will open an establishment at 2d and Market Sts., about Nov. 6th.

Henry Stauntz, successor to H. Litchfield, 719 Sansom St., has returned to his old position with T. S. Mitchell.

A. C. White has purchased the business of George H. Mutchler, 34 N. 15th St. Mr. White was formerly a clerk in the Mutchler establishment.

Purchasers from adjoining places here during the week included: H. Watson, Manayunk; B. Foster, Bristol, Pa.; J. E. Steele, Carlisle, Pa.; R. G. Porter, Woodbury, N. J.

The material department of L. A. Scherr & Co. has been enlarged, owing to increased business, and a mailing department has been added for the convenience of out-of-town customers.

Letters of administration were last week granted by the Register of Wills in the estate of Rembrandt P. Davis, whose death was announced in last week's CIRCULAR. The value of the estate is placed at \$10,000.

A. P. Fritz, the alleged head of the "A. P. Fritz Watch Purchasing Club," was on Tuesday held in \$1,000 bail for court by Magistrate Pallinger, charged with obtaining money by false pretenses.

Orders were secured in Philadelphia by the following last week: Frank L. Wood, Carter, Sloan & Co.; Fred Clarkson, Snow & Westcott; C. F. Duffy, Enos Richardson & Co.; Mr. Brooks, Brooks & Pike; Henry K. Ingram, Alling & Co.

### Buffalo.

Fred King, returned from a three weeks' trip through Ohio, reports trade to be good.

Mr. Kirberger, buyer for Morck Bros., Warren, Pa., spent several days in town last week visiting his brother.

Mr. Schneider, formerly with C. P. Henn, and his brother have opened a jewelry store on Genesee St., corner of Hickory, under the name of Schneider Bros.

The following out-of-town jewelers were here last week: B. T. Sewell, Bradford, Pa.; F. E. Burton, Niagara Falls, N. Y.; Ira Adams, North Java, N. Y.; R. C. Holmes, Gowanda, N. Y.

### Remarkable Specimen of Die Work.

A HANDSOME medal which well illustrates the perfection which is now attained in artistic die work is the "Football Match" medal here illustrated. The design is from the celebrated painting of that name by W. H. Overend and L. Smythe. In the reproduction on the medal



the figures of the players are all in *bas relief* and though reduced to but one quarter of an inch high, they show perfect modeling and pronounced detail work. Though a magnifying glass is required to thoroughly perceive them, in the expression of the face and posture, emotion and excitement are depicted almost as well as in the painting itself. The 21 figures are contained in a space one inch long and one quarter of an inch high. The medal itself is but 1¼ inches in diameter.

The design on the reverse side combines a football, goal bars, American eagle and shield and branches of laurel and oak typifying victory and strength. Across the top is a ribbon for an inscription. The medal which is a venture of Victor B. Brenner, die cutter and medallier, New York, is intended for a football trophy or souvenir. It will be struck in bronze, silver, gold and other metals.

### The Old Game of Posing as a Priest is Worked Successfully.

PITTSBURGH, Pa., Oct. 27.—One day this week an individual in clerical garb entered the store of Weisser Bros., Penn Ave., and introduced himself as Father Cunnigham, a well known priest of Turtle Creek. He said that his Sunday school was trying to raise a special church fund and that it had been decided to purchase two watches, to be given as prizes to the best solicitors. As it was a church affair, the firm agreed to let him have the goods at cost price, and he selected two timepieces valued at \$45. They were to be paid for as soon as the fund was turned over to him by the collectors.

The firm waited until the appointed time for settlement, but the money was not forthcoming. A few days later one of the clerks saw a man coming out of a downtown saloon whom he was sure was the latter, except that he was not in clerical dress. One of the members of the firm went to Turtle Creek to see the real Father Cunnigham, and he was satisfied that the firm had been duped.



## Our Traveling Representatives

Traveling representatives may consider these columns open for the publication of any news or items of interest regarding themselves or their confreres.

THE following traveling salesmen passed through Detroit last week: Walter Shute, Day & Clark; W. C. Coombs, E. P. Sanford & Co.; J. A. Granbery, Reeves & Sillcocks; C. L. Joralemon, A. Joralemon & Co.; O. C. Lane, Reed & Barton; C. W. Cary, J. B. & S. M. Knowles Co.; E. P. Hutten, Geoffroy & Co.; William T. Gough, Carter, Sloan & Co.; Nat. D. Prentiss, Alling & Co.; H. J. Fink, Keller, Ettinger & Fink; A. A. Wood, Howard Sterling Co.; Charles E. Dorr, Gorham Mfg. Co.; David Kaiser, Lewis, Kaiser & Luthy; and a representative of the Metallic Art Works, Brooklyn.

Mr. Rockwell represented Rogers & Brother last week in Boston, Chris. Morgan being under the weather.

Manager Lyons, of Lazarus, Rosenfeld & Lehmann, art porcelain and cut glass, 66 E. Lake St., Chicago, has returned from his

Pacific coast trip. M. J. S. Hofman, traveler for the company, has completed his trips in Michigan, Indiana, Illinois and Iowa, and left the past week for Wisconsin cities.

Traveling men calling on Davenport, Ia., jewelers the past week were: E. A. Reed, Reed & Barton; Morris E. Wolfe, Lapp & Flershem; G. H. Linton, F. M. Whiting & Co.; F. L. Carpenter, Battin & Co.; J. W. Squire, E. Ira Richards & Co.; K. J. Bemis, Landers, Frary & Clark; Frank Thompson, F. Kroeber Clock Co.; S. Guggenheim.

Traveling men visiting the Indianapolis trade last week included the following: Fred Phillipps, A. & J. Plaut; J. T. Metcalf, R. Blackinton & Co.; E. A. Tyler, Ansonia Clock Co.; W. H. Guyre, Waterbury Clock Co.; J. J. Somers, T. Totten & Co. W. J. Miller, Seth Thomas Clock Co.; Mr. Fogg, Keystone Watch Case Co.; E. L. Mumford, Waite, Thresher Co.; M. L. Jacoby, Providence Stock Co.; Geo. C. Booth, Hutchison & Huestis; J. S. Richter, Bruhl Bros. & Co.; A. Marshuetz, Spencer Optical Mfg. Co.; C. E. Bates, R. L. Griffith & Son.

Travelers whose good nature indicated a successful business trip were seen in Chicago in the persons of W. F. Smith, Newark Tortoise Shell Novelty Co.; J. B. Beach, Wilcox Silver Plate Co.; representative G. L. Vose & Co.; Mr. Wilkinson, W. S. Hough, Jr. & Co.; Mr. Somers, Thomas Totten & Co.; J. G. Fuller, J. G. Fuller & Co.; Mr. Booth, Hutchison & Huestis;

Mr. Whiting, S. E. Fisher & Co.; Mr. Hodges, E. A. Potter & Co.; Mr. Pearce, Short, Nerney & Co.; Mr. Ripley, Watson, Newell & Co.; E. L. Mumford, Waite, Thresher Co.; Mr. Stern, Young & Stern; J. A. Granbery, Reeves & Sillcocks.

Traveling men in Boston the past week included: A. Adler, Boss Mfg. Co.; E. A. Woodmancy, Potter & Buffinton; A. C. Smith, A. C. Smith Watch Co.; John A. Abel, Lewis, Kaiser & Luthy; J. D. Pettengill, Derby Silver Co.; T. B. Wilcox, Pairpoint Mfg. Co.; Mr. Crandall, Crandall & Pardee; T. G. Frothingham; Nelson Davis; C. M. Robbins; F. H. Sadler; Mr. Rockwell, Rogers & Brother; A. Krower, Albert Lorsch & Co.; Mr. Bass and Mr. Kaufman, Bruhl Bros. & Co.; Frank Sherry, Joseph Fahys & Co.; Henry G. Thresher, Waite, Thresher Co.

Representatives of wholesale houses in Syracuse, N. Y., the past week were: A. N. Dorchester, Kent & Stanley Co.; Frank W. Harmon, M. B. Bryant & Co.; Jas. A. Cheney, Ludwig Nissen & Co.; R. T. Supple, for William B. Durgin; Mr. Smith, Smith & Knapp; Mr. Brooks, Brooks & Pike; Mr. Cook, Bergstein & Son; Harry R. Ingraham, Alling & Co.; Frank G. Moyer, Max Freund & Co.; L. H. Bosworth, Potter & Buffinton; Arthur Lape, Simpson, Hall, Miller & Co.; C. F. Goodwin; Mr. Rosenbaum, B. H. Davis & Co.; J. Bernstein; J. A. Watts, Meriden Silver Plate Co.; S. H. Sleeper, Stevens Silver Co.; C. E. Barber, Gorham Mfg. Co.; C. L. B. Snedeker, E. Aug. Neresheimer & Co.; H. Lederer, S. & B. Lederer; H. E. Kingman, G. A. Dean & Co.; Geo. F. Greene, Geo. F. Greene & Co.; H. H. Dillingham, N. H. White & Co.; L. T. Field, W. G. Clark and Co.; Frank Schonreek, Deitsch Bros.; L. E. Waterman, Jr., L. E. Waterman Co.; Otto H. Wolff, Bippart & Co.; Fred. Clarkson, Snow & Westcott.

### Syracuse.

Jeweler Charles E. Padelford, Victor, N. Y., was in town last week.

Geo. E. Wilkins returned Wednesday morning from a trip to New York.

W. P. Hitchcock, of Hitchcock & Morse, has returned from a three weeks' trip through Vermont, New Hampshire and Connecticut.

Simon Lesser, of A. Lesser's Sons, is in New York on business bent. S. H. Lesser, of the same firm, has returned from a trip through Ohio.

Eugene B. McClelland has just had placed in position four additional fixtures for electric lighting which are new and novel. The device consists of a brass standard located between the show cases and reaching from the floor to a convenient height above them. At the top of this is a large brass knob above which is a cone shaped globe and at the sides are two more globes, pendant from the branching arms of the standard. It is an effective and pleasing scheme for lighting up the contents of the show cases.

# NOVELTIES

IN

ROYAL WORCESTER,  
COALPORT, MINTON,  
POINTON, DOULTON,  
CROWN DERBY, Etc.

FRENCH FANCY GOODS, REAL <sup>AND</sup> IMITATION BRONZES,  
CLOCKS, PEDESTALS, ETC., ETC

Special attention is invited to our lines of TEA CUPS,  
CHOCOLATE CUPS, AFTER DINNER COFFEES and MOUS-  
TACHE CUPS.

## LE BOUTILLIER & CO.,

860 BROADWAY,

Northeast Corner of 17th Street,

NEW YORK.

**News Gleanings.**

W. W. Scudder will open a jewelry store in Decatur, Ill.

R. P. Starbuck will open a jewelry store in Grant City, Wyo.

C. E. Lewis will open a jewelry store in Niagara Falls, N. Y.

W. B. Greenland has opened his new jewelry store on Main St., Johnstown, N. Y.

Frank VanMarker, jeweler, Ludlow, Pa., and Miss Anna Lindgren, of the same place, were married recently.

Harry Harmon, Tingley, Ia., has sold his jewelry store to a gentleman named Martin, from Atlantic, Ia.

Benj. Spicer has opened a jewelry repair shop in the store of his brother, E. H. Spicer, Watkins, N. Y.

L. D. Achim, Spencer, Mass., will occupy a part of the lower floor of W. J. Heffernan's new block.

L. C. Show, Columbia City, Ind., has moved his watch repairing shop from his residence to William Meitzler's shoe store.

On Nov. 1st will occur the marriage of John S Baird, jeweler, Watertown, N. Y., and Miss Milly B. Stiles, of Middletown, Conn.

D. B. Strait has purchased an interest in the store of Olaus Thorsrud, Eureka, S. Dak., and the firm name is now Thorsrud & Strait.

The business of J. G. Willeke, Springfield, Mo., has been reorganized into the J. C. Willeke Jewelry Co., Paul Ellenberg continuing the business.

Two boys are supposed to have committed the robbery at the jewelry store of Gus Lanz, Norristown, Pa., and the police are following up the clue.

Oscar Yost, Shenandoah, Pa., will shortly remove to Bloomsburg, where he intends to locate. Mr. Yost has been a resident of the former place for more than 25 years.

The jewelry store of C. E. Bowers, Bristow, Ia., was recently entered by burglars and the safe blown open. Thirty watch cases, six gold watches and \$50 in money were stolen. The job was evidently done by professionals.

The jewelry store of T. L. Peck, Sinclairville, N. Y., was burglarized recently. Some valuable watch chains and bracelets were the only articles secured. Entrance to the store was effected by breaking a window.

Alton Deisher, jeweler, Harrisburgh, Pa., who was prevented from being married recently on account of illness, has returned home with his bride, the marriage having occurred on Friday, Oct. 19, at her home in Hamburg.

The store of L. Frank & Litotz, McKeesport, Pa., was burglarized during the night of Oct. 23d. A case in front of the store containing four dozen rings and other jewelry said to be valued at \$300 was rifled of its contents.

S. R. Cohen's jewelry store, 1929 Niagara St., Buffalo, N. Y. was entered by burglars Monday night last. The place was thoroughly ransacked. Three gold watches, a few gold rings, some plated chains and clothing were stolen.

The jewelry stock of D. E. Matthews, Atchison, Kan., which was packed for shipment, was attached some days ago by the sheriff, to satisfy a debt of \$175 due Alva C. Trueblood for services rendered. The matter was amicably settled in a few hours and the goods were released. Mr. Matthews has moved to Chicago.

A party broke into the jewelry store of E. Fry, Belleville, Kan., a short time since and stole a tray of jewelry and hid it under the railroad bridge that crosses the Rock Island railroad, where it was found last week by David Perry, who reported the facts to the officers. A watch was set upon the stolen goods and in about half an hour a young man about town was looking for the goods and was taken by the officers, when he confessed to the theft.

**CAMPBELL-METCALF SILVER CO.**

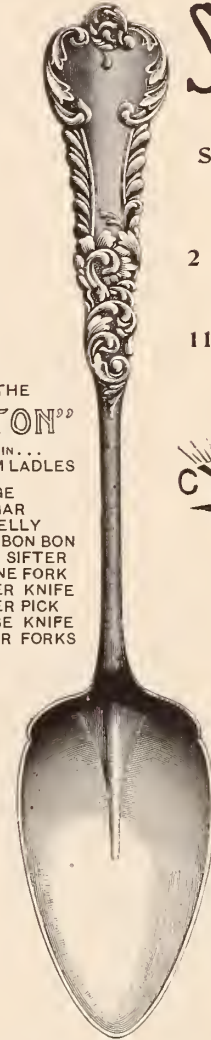

THE "ETON"  
... IN ...  
CREAM LADLES  
ORANGE SUGAR JELLY BON BON SUGAR SIFTER SARDINE FORK BUTTER KNIFE BUTTER PICK CHEESE KNIFE OYSTER FORKS ETC.

FACTORY:  
STEWART ST.,  
PROV., R. I.

N. Y. OFFICE:  
2 MAIDEN LANE.

SAN FRANCISCO:  
112 KEARNY ST.



OUR "ETON" AND "STUART" PATTERNS ARE IMMENSELY POPULAR AND SELL AT SIGHT WRITE DIRECT TO FACTORY FOR SAMPLES AND PRICES.

ARE YOU PUSHING THE SALE OF **TRENTON MOVEMENTS?**



6 Size, 7 Jewels.

For intrinsic value and great merits combined, with **LOWNESS of PRICE**, they far surpass any movements ever placed on the market.

A sample line will thoroughly convince you that it will be to your advantage to handle them extensively.

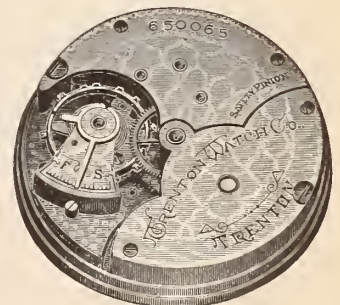

16 Size, 16 Jewels.

INSIST UPON HAVING THEM.

**TRENTON WATCH CO., TRENTON, N. J.**

E. Rose, Joplin, Mo., is selling out at auction.

Parker & Morse, Maynard, Mass., have dissolved.

Elias B. Berry, West Boylston, Mass., died recently.

James Eichel, Passaic, N. J., has given a mortgage for \$1,000.

I. M. Reynolds, Cohocton, N. Y., has given a mortgage for \$2,200.

John A. Beltzer, Ogden, Utah, has given a mortgage for \$300.

Charles Rueff, Louisville, Ky., has given a mortgage for \$757.

William Crippin has opened a jewelry store in Whitestown, N. Y.

J. L. Goldstein, Springfield, Va., has given a chattel mortgage for \$300.

Joseph Eckart, Brenham, Tex., has made an assignment to B. F. Teague. Liabilities, \$4,000; assets about \$6,000.

The jewelry stores of C. T. Tyler and J. Martin, New Carlisle, Ind., were damaged by fire on the morning of Oct. 24.

Miss Maud Church, daughter of jeweler C. H. Church, Logansport, Ind., was married last week to D. B. Johnson.

The factories of Southbridge, Mass., are very busy, large orders being received daily by the American Optical Co., the Southbridge Optical Co., and the Dupaul-Young Co.

The Sternberg Jewelry Co., Savannah, Ga., announce that they offer their entire stock at auction. J. H. French is the auctioneer. The sale commenced Oct. 24, at 10.30 o'clock A.M.

Samuel A. Patterson has been appointed administrator of the estate of Herman Schmidt, Asbury Park, N. J. The estate is valued at \$5,000, and consists of money in bank and business stock. There are five heirs, children of Mr. Schmidt, who reside in New York.

Bert L. Davis, New Richmond, Wis., committed suicide last Tuesday afternoon. He bought out a jewelry store here two weeks ago, having come from Spooner, where he formerly was engaged in business. He was about 22 years old.

The J. M. Donelson Jewelry and Manufacturing Co., of Minneapolis, Minn., filed articles of incorporation last week. The capital stock is placed at \$25,000 and the limit of liability at \$10,000. The incorporators are John B. Flannigan, Ezra W. Aldrich and Joseph M. Donelson.

Ever since the discovery of pearls in the Wabash River other Indiana streams have been explored for them with satisfactory results. They are found down in Big Pipe Creek valuing from \$2 to \$50; up in Eel river, and in the Maumee at Fort Wayne where a city officer has found and has in his possession at least \$500. worth.

"Our Salesman" for 1895, now ready and being sent out by F. M. Sproehnle & Co., Columbus Memorial building, Chicago, is worthy the close examination of every jeweler and properly used will answer in many requirements the purposes of a large and well selected stock. Starting with diamonds, which require many pages of the book, with numerous illustrations, the work comprises all the lines carried by well appointed jewelry stores. To present these lines in a manner attractive and valuable to the retail jeweler requires a volume of 640 pages. The prices given are those at which the jeweler sells the goods and the book left on the counter, wide opened, will prove a good salesman in itself. The prices quoted are subject to a uniform catalogue discount that will give a large margin of profit to the retailer. Send for the book and watch results.

**HAVE YOU RECEIVED OUR PRICE LIST? OF DIAMOND MOUNTINGS.**

If not, send your business card and we will send you one.



Manufacturing Jewelers. OFFICE AND FACTORY,

**LEONHARDT & CURRAN, 57 Maiden Lane, New York.**

**RICH CUT GLASS.**

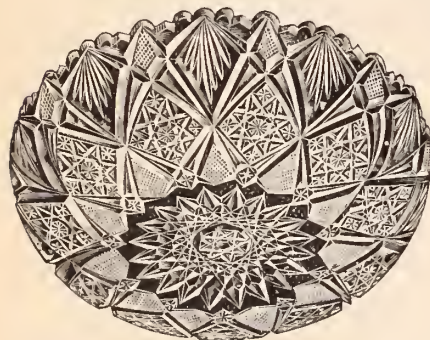

7 INCH NAPPY. SAVOY CUTTING. BOTTOM VIEW. The illustration does not fully show the handsomely scalloped edge.

The Pattern herewith shown is that long desired medium between the Strawberry Diamond Fan and the higher priced cuttings. The HURON and some other moderate priced patterns have been much liked by jewelers, but the SAVOY has taken them by storm. We specially recommend it to that trade.

**T. B. CLARK & CO., Inc., 860 BROADWAY, NEW YORK,**

Factories, HONESDALE, PA.

North East Cor. 17th St. and Broadway.



**ONE OF THE 400, AND VERY SWELL INDEED.**

**THE PERFECT FIT OF OUR No. 918 GOLD EYE GLASS, SWELL END EYE WIRE.**

Our Ambition to Make a FAULTLESS GOLD SPEC. and Eye Glass has been realized, and is appreciated. Strength and Beauty Joined Together WITHOUT SOLDER. You "see that hump" no longer. It's gone, and in its place, at ends and bridge, you find that GRACEFUL SWELL, as shown in cut. *This is the Modern and Perfect Frame the public are asking for, made in all weights, sizes, shapes and qualities.*

**WE MAKE ALL KINDS OF OPTICAL SPECIALTIES, AND TEACH HOW TO GET BEST RETURNS IN HANDLING THEM.**

Just Received our Fall Importation.

**THE AUDEMAIR OPERA GLASSES, SPENCER OPTICAL MFG. CO., 15 MAIDEN LANE, NEW YORK.**

**CALL OR WRITE. IT WILL DO YOU GOOD!**

The Best Made for the Least Money. Also Cheaper Grades. The Greatest Variety of Styles. Great Reductions to Correspond with New Tariff and Other Causes. SEND FOR NEW SUPPLEMENT.





**English Weights and Measures.**

**T**HE jewelers of the middle ages used in their delicate scales the hard brown seeds of the Moorish carob tree (*Ceratonia siliqua*), and the weight of diamonds is still reckoned by karats, each karat being equal to  $3\frac{1}{8}$  grains troy. The earliest attempt to regulate British weights and measures appears to have been suggested by this example. In 1266 it was declared by statute than "an English penny, called a sterling, round and without any clipping, shall weigh 32 wheat corns in the midst of the ear; and 20 pence do make an ounce, and 12 ounces one pound, and eight pounds do make a gallon of wine, and eight gallons of wine do make a London bushel, which is an eighth part of a quarter."

We have here the basis of the British system of reckoning as it survives to-day—the grain, pennyweight, ounce, pound, gallon, bushel, and ton, and 240 silver pence equal to a pound sterling. The British gallon is still used for both dry and liquid measure, and the traditional relation between the pound and the gallon is set forth in the old rhyme, which declares that

A pint's a pound  
The world around.

In 1324, the measures of length were defined by a similar statute providing that "three barleycorns, round and dry, laid end to end," shall make one inch, 12 inches a foot, and 3 feet a yard. The 32 wheat corns, adopted as the basis of the British system, appeared to have weighed  $22\frac{1}{2}$  grains troy, so that the pound of 1266 was equal to 5,400 grains troy. This is the old Saxon pound. The pound troy (pound *du roy*) is the Roman pound, and was doubtless in use simultaneously with the Saxton pound for hundreds of years, but first mentioned in the statutes in 1414, and was ordained as the standard weight for gold and silver in 1527. As 24 grains made a pennyweight troy, the new pound contained 5,760 grains, exceeding the old weight by 360 grains, or three-quarters of an ounce. The strict pound of 12 ounces was used only in weighing the precious metals, and, with different subdivisions, for the costly drugs and medicines dealt out by apothecaries. For heavy goods (*avoirs du poids*) a more liberal measure was given, like the baker's dozen, and 15 ounces were called a pound. In the same way 28 pounds were called a quarter, and 112 pounds a hundredweight, allowance being made for waste or wrapping.

The increase of the pennyweight to 24 grains in 1527 raised the value of the ounce

to 480 grains; and accordingly the pound of commerce, containing 15 ounces, was raised to 7,200 grains. As 250 grains of wine were reckoned equal to a cubic inch, the gallon containing eight of these pounds, or 57,600 grains, had a capacity of 230.4, or in even numbers 231 cubic inches. This is the wine gallon now in use in the United States. The ale or beer gallon, of 282 cubic inches, was originally a measure containing eight pounds of wheat at 204 grains to the cubic inch. The name avoirdupois was transferred at a very early date from the heavy goods, which it indicated, to the system by which they were weighed. It occurs first in the statutes of 1335 and 1353. The early pound of 15 ounces of 450 grains each, 6,750 grains, was raised by law, as has been shown, to 7,200 grains, making 16 of the old ounces. In practice, however, the pound seems to have fallen below this standard to about 7,000 grains, and this weight was finally declared to be a pound avoirdupois, the avoirdupois ounce, or sixteenth of the pound, being thus reduced to  $437\frac{1}{2}$  grains.

MISUNDERSTOOD THE TEXT.

"Now tell me what the trouble is," said a mother to her little girl whom she had just been obliged to take out of church because of a violent fit of weeping.

"He called me," said the child between her sobs, "a simple, little cross-eyed thing."

The child was cross-eyed, and the minister had just given out the hymn: "Simply to Thy Cross I Cling."—*Exchange*.

A SPITEFUL REMARK.

"Dorrible says he wouldn't have the nomination though it were offered to him on a silver platter."

"That may be so," said Dorrible's rival, "but I would hate to take any chances—with the platter."—*Cincinnati Tribune*.

POOR THING.

She was at Manhattan Beach, and seemed to be not more than three years old, but she was near sighted and wore spectacles. She wanted to paddle in the water and spoil her russet shoes. Her nurse had been forbidden to let her go barefoot, and baby began to sob. Then she cried:

"Take 'em off, Mary! Take 'em off!"

The reporter thought she referred to her shoes; but she went on:

"Take off my spettatles, Mary, so I can cry!"—*New York Recorder*.

**Movement to Establish a Massachusetts State Jewelers' Association.**

Boston, Mass., Oct. 30.—A movement is under way among Massachusetts jewelers to form a State organization for private purposes. County organizations of a similar character have been formed in Worcester, Hampden, and Berkshire counties, and if a few more can be got under way in Suffolk, and one or two other counties, it is expected that a State Association will be formed, with headquarters in this city.

Newton Dexter is said to be the prime mover in the work, and the object is to correct trade abuses, and incidentally oppose the encroachment of the department stores. Boston has a Jewelers' Club, but it is composed exclusively of manufacturers and wholesalers.

The commencement of the theatre season once more, gives rise to an increased demand for the "Mack" opera glass holders, the only articles of the kind on the market. Since the courts have decided that all similar holders are infringements on Judge Mack's patent, the only firm permitted to manufacture these holders has been the Julius King Optical Co., 14 Maiden Lane, New York, who control these patents. This company have lately added a number of new styles to their line and have made big reductions in prices, so that the demand for these goods will now be necessarily greater than ever before.



THE WAVE  
PATENTED.

Enamel Painted Portraits done by Photography and Hand Painted on Porcelain or Enamel at one-half the prices you used to pay. Pictures from Celebrated Galleries, Club Devices Applied in Enamel. Repairing.

Half Pearl, Diamond, Gold and Sterling Silver Scarf Pins, Brooches and Novelties.

**Clarence W. Sedgwick,**

11 EAST 20th STREET, NEW YORK.



**The St. Louis Ophthalmic College and Hospital**

A SCHOOL OF THEORETICAL AND APPLIED OPHTHALMIC OPTICS.

1655 SOUTH JEFFERSON AVENUE,

N. W. Corner Lafayette Avenue, - - ST. LOUIS, MO.

For the Announcement and further information, address Ignatz Mayer, M. D., President.

**Boston.**

TRADE CONDITIONS.

The railroads centering in the Hub have been running some excursions from various sections of New England during the past ten days and quite an influx of buyers has resulted. Trade has hardly kept up the pace that it was making at the beginning of the month, however, the volume of business being perceptibly lighter with the jobbers

as a rule. Retailers on the other hand, find business very fair and are hopeful regarding the holidays.

From a jobbing house that carries a line of gold spectacle and eyeglass frames, the information was imparted that it is very difficult at present to obtain gold goods from either the American Optical Co., Southbridge, Mass., or the Standard Optical Co., Geneva, N. Y., both being way behind

on orders. The foreman of a department at the factory in Southbridge was also quoted as saying that he never had so many orders in so short a time as he has received since August this year. This concern and its rush of business are held up as an example of returning prosperity, by the Democratic candidate for Governor of this State in his campaign speeches.

It should be said of the present situation that it is not discouraging, even though the lighter business above referred to might seem to be a setback. There is more inquiry and customers who put in an appearance at Boston jobbing houses are looking for goods that can be used to advantage during their holiday trade now so close at hand. In this respect the outlook is promising for a very satisfactory rush as soon as the Fall elections are out of the way.

A. W. Harmon, Canadian agent for the American Waltham Watch Co., was in town the past week.

J. F. Bartlett, L. H. Whitney, A. W. Ladd, jewelers of Clinton, Mass.; Jack Hollister, with the Luther Chain Co.; and F. L. Bennett, with E. A. Whitney Co., attended the cattle show at Sterling, Mass., last week.

The co-partnership heretofore existing between E. B. Floyd and W. H. N. Pratt has been dissolved by mutual consent, and Mr. Pratt retires from the business. Mr. Floyd will continue at the same location, and the firm name of Floyd, Pratt & Co. is superseded by that of E. B. Floyd & Co.

J. H. Rowell, Solon, Me., was cordially greeted by many friends in the trade last week. He was in town on his annual holiday buying trip. F. R. Cottrell, who has just opened a new store in Burlington, Vt., was another buyer in town. There were numerous other prominent retailers here, among them being: Charles Morse, Colebrook; B. P. Lamb, Greenville; W. I. Hatch and J. M. Kimball, Lancaster; W. M. Carr, Bradford; Charles Temple, of Temple & Farrington, Manchester; E. Flint, Littleton, N. H.; Mrs. E. N. Nelson, Craftsbury; J. L. Swasey, Newbury; L. F. Forten, Plainville; H. A. Belknap, St. Johnsbury; John Wyman and Benjamin Perkins, of Chas. Wyman & Co., St. Albans; C. E. Mudgett, Fairfax, Vt.; George H. Griffin, Portland; E. R. Bumps, Thomaston; J. B. Williamson, Camden; D. W. Springall, Dexter; O. W. Hall, South Norridgewock, Me.; L. H. Smith, North Easton; S. G. Beers, Taunton; H. A. Stone, Ayer, Mass.

**Springfield, Mass.**

Emery C. Watson, manager for O. W. Bullock & Co., the watch tool makers has been nominated by the Democrats for representative in the sixth district. The district is Republican but it is thought that Mr. Watson will make a strong run if indeed he does not secure an election.

**DIAMONDS.**

**Wm. S. Hedges & Co.,**

Importers of Diamonds.

And Manufacturers of DIAMOND JEWELRY.

170 Broadway, New York.

22 Holborn Viaduct, London.

**Alfred H. Smith & Co.,**

IMPORTERS

**DIAMONDS**

AND

**PRECIOUS STONES,**

182 BROADWAY, COR. JOHN STREET,

NEW YORK.

22 Holborn Viaduct, London, E. C.

**R. A. KIPLING,**

Precious Stones

AND Fancy Goods

Bought and Sold on Commission.

19 RUE DROUOT,

PARIS, FRANCE.

**O. NEWMAN,**

Successor to L. NEWMAN.

GOLD and...  
...SILVER **PLATER,**

75 & 77 Nassau St., N. Y.

Owing to the death of my father, I beg leave to notify our customers and the trade that the business will be continued by me at the old stand with new improvements, which will produce better results.

Etruscan Coloring a Specialty.

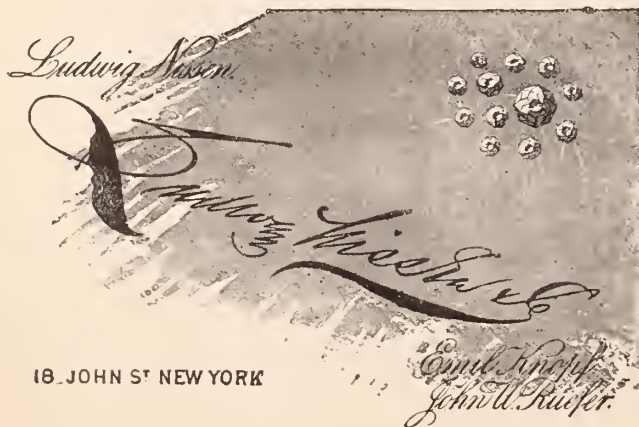

The jewelry store of Chauncey O. Knight, in Dalton, was broken into one night last week and the burglars secured a large amount of booty. The job was probably done by a gang of thieves who are operating in Berkshire county, for a number of places in neighboring towns were robbed at about that time. Fortunately Mr. Knight had his watches and more valuable goods locked up in his safe and the robbers secured only articles of lesser value, but took enough of these to make a good showing.

**Canada and the Provinces.**

The American Watch Case Co., Toronto, have a new 6-size gold filled hunting case on the market.

T. Fitton, of Exeter, visited Toronto last week and made extensive purchases of novelties for the Fall trade.

B. Chapman, formerly with P. W. Ellis & Co., Toronto, has accepted a position with Smith & Patterson, Montreal.

Charles Clarke, representing J. G. Cheever & Co., North Attleboro, Mass., was in Toronto with a choice assortment of new styles of chains recently.

H. K. Danford, representing H. & A. Saunders, Toronto, and James Robertson, representing T. H. Lee & Son, of the same place, are both stopping at the Balmoral, Montreal.

Capt. Spearing, a prominent jeweler of Sherbrooke, Que., has been doing some great rifle shooting lately, and it is likely he will be one of the members of next year's Brisley team.

W. K. McNaught, secretary-treasurer of the American Watch Case Co., Toronto, has been confined to his room the past two months by an accident to his knee-cap sustained while getting off an electric car.

H. Benham & Co., Toronto, have made extensive alterations in their premises and added a line of silver plated and sterling silver goods to their stock. H. Benham has started on a trip through western Ontario.

The authorities of the Canada Southern branch of the Michigan Central R. R., have ordered that every trainman employed on the road must possess a high grade watch. There are some 500 or 600 employes concerned. The Elgin-Raymond nickel or the Waltham Appleton-Tracy watch are the lowest grades that the time-keeper will pass.

Walter J. Barr, of the Goldsmiths' Stock Co., Toronto, who has lately returned from an extended trip through eastern Canada, and the jewelry centres of the United States reports business better in the eastern than in the western portion of Canada. The principal demand is for cheap silver novelties. The clock trade continues comparatively brisk and there is an active demand for "Brownie" jewelry. Purchasers are largely holding over until the holiday season, and the prospects are that December will be a good average month.

ESTABLISHED 50 YEARS.

**RANDEL, BAREMORE & BILLINGS,**

IMPORTERS OF

**DIAMONDS,**

AND OTHER PRECIOUS STONES.

**FINE PEARLS A SPECIALTY.**

MANUFACTURERS OF

**DIAMOND JEWELRY,**

IN THE LATEST DESIGNS.

Diamonds Recut in Modern Styles or Repaired on Premises.

58 Nassau Street,  
29 Maiden Lane,  
NEW YORK.

1 Tulp Straat,  
AMSTERDAM.

1 St. Andrews St.,  
Holborn Circus,  
LONDON, E. C.



TRADE MARK.

ESTABLISHED 1841.

**CARTER, SLOAN & CO.,**

**MANUFACTURERS OF GOLD JEWELRY.**

No. 15 MAIDEN LANE,

NEW YORK.

A. CARTER JR.  
A. K. SLOAN.  
C. E. HASTINGS.

GEO. R. HOWE.  
WM. T. CARTER.  
WM. T. GOUGH.

FACTORY, NEWARK, N. J.



**JOHN N. DISSELKOEN,**

Cutter and Importer of

**DIAMONDS**

FACTORY  
76 LANGEBLEEKERSPAD,  
AMSTERDAM.

19 East 16th St.,  
NEW YORK.



# CLASSIFIED INDEX TO ADVERTISEMENTS.

All Advertisements are entitled to one insertion under proper heading. Extra insertions, \$6.00 per annum  
Extra Headings, \$12.00 per annum.

<b>Art Pottery, Bric-a-brac, Etc.</b>	Page.	<b>Gold and Rolled Plate Jewelry.</b>	Page.	<b>Safes.</b>	Page.
Bing, Ferdinand & Co., 106 Grand St., N. Y. . . . .	48	Foster & Bailey, Providence, R. I. . . . .	9	Mosler, Bahmann & Co., 518 B'way, N. Y. . . . .	14
Bradley & Hubbard Mfg. Co., Meriden, Conn	16	Smith, Wm., & Co., 5-7 Maiden Lane, N. Y. . . . .	4	<b>Sample Trunks.</b>	
Glaenzler, Leon J. & Co., 80 & 82 Chambers St., N. Y. . . . .	3	Schwartz, W. H., & Co., Newark, N. J. . . . .	51	Crouch & Fitzgerald, 161 Broadway, N. Y. . . . .	5
Hinrichs & Co., 29 & 31 Park Place, N. Y. . . . .	51	<b>Gold and Silver Platers.</b>		<b>Show Cases.</b>	
Healey, M. & E., Washington, D. C. . . . .	41	.. Newman, O., 75-77 Nassau St., N. Y. . . . .	30	Smith, B. & W. B., 220 W. 29th St., N. Y. . . . .	52
Le Boutillier & Co., 860 Broadway, N. Y. . . . .	26	<b>Gold Jewelry.</b>		<b>Silver Plated Ware.</b>	
Vantine, A. A. & Co., 877 & 879 B'way, N. Y. . . . .	50	Carter, Sloan & Co., 15 Maiden Lane, N. Y. . . . .	31	Pairpoint Mfg. Co., New Bedford, Mass. . . . .	6
Straus, L. & Sons, 42 to 48 Warren St., N. Y. . . . .	47	Aikin, Lambert & Co., 19 Maiden Lane. . . . .	8-14	Rogers & Bro., 16 Cortlandt St., N. Y. . . . .	2
<b>Assayers &amp; Refiners.</b>		Cross & Beguelin, 17 Maiden Lane, N. Y. . . . .	3	The Wm. Rogers Mfg. Co., Hartford, Conn. . . . .	5
Baker, Geo. M., Providence, R. I. . . . .	40	Griffith, R. L. & Son, 129 Eddy St., Provi- dence, R. I. . . . .	14	Webster, G. A., Chicago, Ill. . . . .	37
Le Long, L. & Bro., Newark, N. J. . . . .	52	Hedges, A. J. & Co., 6 Maiden Lane . . . . .	4	<b>Sterling Silver Novelties.</b>	
U. S. Smelting & Refining Works, 25 John St., N. Y. . . . .	52	<b>Gold and Silver Jewelry.</b>		Bachrach & Freedman, 1 & 3 Union Sq., N. Y. . . . .	20
<b>Auctioneers.</b>		Chattellier, Jos. F., 860 Broadway. . . . .	8	Codding Bros. & Heilborn, North Attleboro Mass. . . . .	40
Boyle, Davis & Goodman, 63 5th Ave., N. Y., 611 Pennsylvania Ave., Washington, D. C. . . . .	17	<b>Gold and Silver Novelties,</b>		Hagan, White & Co., 243 W. 23d St., N. Y. . . . .	33
Comrie, A. J., 22 John St., N. Y. . . . .	40	Riley, John A. & Sloan Co., Broadway and 17th St., N. Y. . . . .	16	Richardson, Enos, & Co., 23 Maiden Lane. . . . .	14
French, J. H., P. O. Box 2775, N. Y. . . . .	35	<b>Guards, Scarf Pins.</b>		Sedgwick, C. W., 11 E 20th St., N. Y. . . . .	29
H. M. Rich & Co., 21 School St., Boston, Mass. . . . .	40	Security Mfg Co., 7 Astor House, N.Y. . . . .	16	<b>Sterling Silverware.</b>	
<b>Badges, Medals, Etc.</b>		<b>Horological Schools.</b>		Campbell-Metcalf Silver Co., Providence, R. I. . . . .	27
Stockwell, E. R., 19 John St. N. Y. . . . .	17	Chicago Watchmakers' Institute, Chicago, Ill. . . . .	38	Fuchs, Ferd. & Bros., 808-810 Greenwich St., N. Y. . . . .	16
<b>Carborundum.</b>		Parson's School for Watchmakers, Peoria, Ill. . . . .	37	Shiebler, G. W. Co., 179 Broadway, N. Y. . . . .	13
The Carborundum Co., Monongahela, Pa. . . . .	8	Philadelphia College of Horology, 623 Heed Building, Phila., Pa. . . . .	17	Towle Mfg. Co., Newburyport, Mass. . . . .	16
<b>Clocks, French, English and American.</b>		<b>Insurance.</b>		Wallace, R. & Sons Mfg. Co., 3 Park Place, . . . . .	6
Jacques, Chas., Clock Co., 22 Cortlandt St., N. Y. . . . .	52	Fidelity & Casualty Co., 140-146 Broadway. . . . .	51	Wood & Hughes, 16 John St., N. Y. . . . .	43
<b>Cut Glass.</b>		<b>Jewelry, Silverware and Optical Cases.</b>		<b>Spectacle and Eyeglass Cases.</b>	
Clark, T. B. & Co., 860 Broadway, N. Y. . . . .	28	Jackson, S. C., 180 Broadway, N. Y. . . . .	16	White, W. B. & Son, Boston, Mass. . . . .	43
<b>Diamond &amp; Precious Stone Importers.</b>		Steinhaus, T. C., 10 Maiden Lane, N. Y. . . . .	14	<b>'Thimbles.</b>	
Disselkoen, John N., 19 E. 16th St., N. Y. . . . .	31	Hebbard & Bros., 860 Broadway N. Y. . . . .	9	Ketchum & McDougal, 198 Broadway, N. Y. . . . .	41
Falkenau, Oppenheimer & Co., 40 Maiden Lane, N. Y. . . . .	52	<b>Jobbers, Watches, Diamonds, Etc.</b>		<b>Tortoise Shell Goods.</b>	
Friedlander, R., L. & M., Ltd. 30 Maiden Lane, N. Y. . . . .	41	Allen, Benj. & Co., Chicago, Ills. . . . .	16	Potter, W. K., Providence, R. I. . . . .	35
Hedges, Wm. S. & Co., 170 Broadway, N. Y. . . . .	30	Aikin-Lambert Jewelry Co., 19 Maiden Lane . . . . .	8-14	Rice & Hochster, 415 Broadway. . . . .	7
Kahn, L. & M. & Co., 172 Broadway, N. Y. . . . .	52	Brethauer Watch and Jewelry Co., Chicago, Ill. . . . .	37	<b>Tool Manufacturers and Dealers.</b>	
Kipling, E. E. 182 Broadway, N. Y. . . . .	52	Myers, S. F. & Co., 48 Maiden Lane, N. Y. . . . .	52	Allen, Benj. & Co., Chicago, Ill. . . . .	37
Kipling, R. A., Hays Bldg., N. Y. . . . .	30	Marquardt, G. W. & Sons, Chicago, Ill. . . . .	37	American Watch Tool Co., Waltham, Mass. . . . .	42
Lorsch, Albert & Co., 37 Maiden Lane, N. Y. . . . .	52	Oskamp, Nolting Co., Cincinnati, O. . . . .	37	Lowell Wrench Co., Lowell, Mass. . . . .	40
Nissen Ludwig & Co., 18 John St. . . . .	30	Oppenheimer Bros. & Veith, 35 Maiden Lane, N. Y. . . . .	24	Moseley & Co., Elgin, Ill. . . . .	37
Randel, Baremore & Billings, 29 Maiden Lane . . . . .	31	Sproehle, F. M. & Co., Chicago, Ill. . . . .	39	Oliver, W. W., Buffalo, N. Y. . . . .	52
Smith, Alfred H. & Co., 182 Broadway, N. Y. . . . .	30	<b>Musical Boxes.</b>		Swigart, E. & J., 101 W. 5th St., Cincinnati, O. . . . .	41
Tannenbaum, L., & Co., cor. Maiden Lane and Nassau St., N. Y. . . . .	23	Cuendet, L. J., 21 John St., N. Y. . . . .	40	<b>Trunks and Traveling Bags.</b>	
<b>Diamond Cutters.</b>		Jacot & Son, 39 Union Square, N. Y. . . . .	52	Crouch & Fitzgerald, 161 Broadway, N. Y. . . . .	5
Arnstein Bros., 45 John St., N. Y. . . . .	34	Wolfe, A., 194 Broadway, N. Y. . . . .	41	<b>Watch Manufacturers.</b>	
<b>Diamond Jewelry.</b>		<b>Ophthalmic College.</b>		A. C. Smith Watch Co., 177 Broadway . . . . .	0
Jeanne, Paul, Bradley Bldg., N. Y. . . . .	24	St. Louis Ophthalmic College, St. Louis, Mo. . . . .	29	American Waltham Watch Co., . . . . .	18
Leonhardt & Curran, 44 1/2 Maiden Lane, N. Y. . . . .	28	<b>Optical Goods.</b>		Trenton Watch Co., Trenton, N. J. . . . .	27
Sauter, L. & Co., 194 Broadway. . . . .	4	Berger, Albert & Co., 47 Maiden Lane, N. Y. . . . .	5	<b>Watch Case Repairers.</b>	
<b>Diamond Polishing Mills.</b>		Geneva Optical Co., Chicago, Ills. . . . .	38	The Planchamp & Becker Co., Chicago, Ill. . . . .	
Arthur Co., The, 86 John St., New York. . . . .	52	Queen & Co., Philadelphia, Pa. . . . .	40	<b>Watch Importers.</b>	
<b>Display-Window.</b>		Spencer Optical Mfg. Co., 15 Maiden Lane, N. Y. . . . .	28	Hyde's, J. E., Sons, 22 Maiden Lane, N. Y. . . . .	43
Pearce, Frederick, 77-79 John St., N. Y. . . . .	35	The Julius King Optical Co., 14 Maiden Lane, N. Y. . . . .	51	Racine, Jules, 180 Broadway, New York. . . . .	46
<b>Fine Stationery.</b>		<b>Pens, Pencils, etc.,</b>		<b>Watch Keys.</b>	
Parsons & Greene Co., 18 Murray St., N. Y. . . . .	5	Aikin, Lambert & Co., 19 Maiden Lane, N. Y. . . . .	8-14	Clark, A. N., Plainville, Conn. . . . .	52
<b>Furniture.</b>		Beaumel, D. W., 17 John St., N. Y. . . . .	40	<b>Watch Repairers.</b>	
Smith, Geo. Wm., 3907 Powelton Ave., Phila., Pa. . . . .	41	Diamond Point Pen Co., 7 Astor House' N. Y. . . . .	40	Henry, Peter, Cincinnati, O. . . . .	37
		LeRoy, Fairchild & Co., 3 Maiden Lane. . . . .	14		
		Smith, H. M. & Co., 83 Nassau St. . . . .	17		
		<b>Ring Makers.</b>			
		Bowden, J. B. & Co., 192 Broadway, N. Y. . . . .	16		
		Bryant, M. B. & Co., 10 Maiden Lane, N. Y. . . . .	4		
		Hildreth Mfg. Co., 53 Maiden Lane, N. Y. . . . .	17		
		Waite, Thresher Co., Providence R. I. . . . .	15		

## Special Notices.

Rates 75c. per insertion for notices not exceeding 3 lines (25 words); additional words 2 cents each. If answers are to be forwarded, postage stamps must be enclosed. Two insertions, 15 per cent. off; three insertions, 20 per cent. off; four insertions or more, 25 per cent. off. Payable strictly in advance. Display cards on this page will be charged at \$2.00 per inch for first insertion, subject to same discount as above for subsequent insertions.

Under the heading of **Situations Wanted** on this page advertisements will be inserted for **One Cent a Word**. This offer refers to **Situations Wanted only**. Payable strictly in advance. If answers are to be forwarded, postage must be enclosed.

## Situations Wanted.

*Notices under this heading ONLY are charged at one cent a word, payable strictly in advance. If answer are to be forwarded, postage must be enclosed.*

**WANTED** to represent in New York manufacture of gold or silver jewelry or sterling silver novelties; have New York office and acquaintance with both jobbing and retail trade. Address Old Traveler, care JEWELERS' CIRCULAR.

**WANTED**.—A position as expert watchmaker. Experience of 20 years on fine complicated watches. Best of city references. Address Hair-spring, care of JEWELERS' CIRCULAR.

**SALESMAN** wants situation on the road at once. Established trade in east. Manufacturer preferred. Best references. Address Hustler, care JEWELERS' CIRCULAR.

A **YOUNG** man, 22 years of age, wishes a position as watchmaker, jewelry repairer, and is a good salesman. For particulars address Alexander, care JEWELERS' CIRCULAR.

By a young man seven years' experience on watches, clocks and jewelry, have not worked at the business for over two years; would like a position with a good firm so as to get familiar with the business again; moderate salary. Address 23, care JEWELERS' CIRCULAR.

By an American watchmaker, jeweler and salesman with complete set of tools and eight years' experience. Best reference. Address Reliable, Box 202, Station A, Meriden, Conn.

**WATCHMAKER** would like position; can do fine and complicated watch work; also French clock work if required. Best references as to ability, etc. Address Curtis, care JEWELERS' CIRCULAR.

**PERMANENT** situation in Colorado. Montana or adjoining States by first-class watchmaker, salesman and fair engraver; complete set of tools; very best of reference; seven years' experience at bench; age 25 years; write stating salary, J. H. Lepper, Grinnell, Iowa.

**SITUATION** wanted by an A1 watchmaker and engraver: sober and reliable; 16 years' experience; A1 reference; have fine set of tools. P. B. L., P. O. Box 412, Winchester, Ill.

**SITUATION** wanted by a first-class watchmaker; will act as salesman if desired. Address K., care JEWELERS' CIRCULAR.

**FIRST-CLASS** watchmaker, jeweler and salesman wants position. Young man; single; 12 years' experience. Best of references. Address C. E. Hagy, Abingdon, Va.

**WANTED**.—A steady position by a first-class watchmaker. Twenty years' experience. Have my own tools. Best of references. A. L., care of JEWELERS' CIRCULAR.

**CAPABLE** young man wants position as watchmaker. Can do all kinds of bench work. Best of references. C. R. Keil, South Kaukauna, Wis.

**WANTED**—A position as optician. Can engrave and do watch, clock and jewelry repairing. Have trial case and tools. Address L. L. L., care JEWELERS' CIRCULAR.

**POSITION WANTED** by a young man 21 years of age, having three years' experience. Can do ordinary watch and clock repairing; also a first class salesman. Can speak German and English, and has some ability as an engraver. Can give best of reference. Address Louis Becker, 702 N. 24th St., Philadelphia, Pa.

**SITUATION WANTED**—By young man as clerk in a wholesale jewelry house; over three years' experience; can furnish A 1 reference. H. C. B., Box 24, Newark, N. J.

**YOUNG MAN** having been in the silverware and china business for himself for several years, wishes to take a position with some firm in the same line in New York or Newark. E. L. Kent, 114 Chestnut St., East Orange, N. J.

**WATCH** and chronometer maker, thoroughly experienced on complicated and plain watch work, seeks position in a first class house, as foreman or otherwise. Garnish, 1313 3d Ave., New York.

**YOUNG** man three years with wholesale jeweler would like a situation where he can advance himself. References. Address Jeweler, care JEWELERS' CIRCULAR.

**PRACTICAL** watch, clock and jewelry repairer wants situation. Has 10 years' experience and own tools. N. Goodman, 60 Cannon St., New York.

**PERMANENT** situation by first-class jeweler, diamond setter and engraver. Best of references. South preferred. Address A., care JEWELERS' CIRCULAR.

**WANTED**—A steady position by a first-class watchmaker, engraver and jeweler. Best of references. Address T. D. Knapp, 116 S. Howard St., Akron, O.

A **YOUNG** man having six years' experience in watchmaking and plain engraving, having American lathe and full set of tools, desires steady position. A1 references. Philadelphia, care JEWELERS' CIRCULAR.

### To Importers of Diamonds and Colored Stones:

A gentleman of many years' experience in the Diamond Trade and formerly representing one of the largest foreign diamond houses, is open for engagement. Address, W. M., care JEWELERS' CIRCULAR.

## Help Wanted.

**WANTED**—Salesman who has had experience in selling silver plated ware to the trade. State experience and full particulars confidentially. No other replies noticed. B., care of JEWELERS' CIRCULAR.

**MANUFACTURING** jeweler: a good all-around man. For full particulars write E. M. Blauvelt, 569 N. High St., Columbus, O.

**WANTED**—Young man as salesman for manufacturing jeweler, one acquainted with the wholesale trade. Address "L," stating particulars, care JEWELERS' CIRCULAR.

## Miscellaneous.

**I BUY JEWELRY STOCKS**—Manufacturers, jobbers and retailers desiring to dispose of surplus or entire stocks of diamonds, watches and jewelry can find quick cash buyer by addressing Stephen S. Harmon, 1240 Lexington Ave., New York City.

**THE NIAGARA FALLS JEWELRY STORE** was not sold last Spring. Have now reduced the stock so can sell at almost your own figures. Holiday trade is soon here; any decent offer will take the whole business. Hurry. Dr. Abiel Bowen, Medina, N. Y.

**DIAMONDS**—I want a line of small diamond rings to sell on commission in the Missouri valley and middle west. Have an established trade and can give satisfactory security on references. Flint Bowen, Room 415, Keith & Perry Building, Kansas City, Mo.

## Business Opportunities.

**ADVERTISER** who has a first-class modern jewelry factory and is a thoroughly practical man, wants partner with about \$5,000 to increase the business; fullest investigation courted. Factory, care JEWELERS' CIRCULAR.

**PARTNER WANTED**—In an established jewelry business in State of Illinois, located where crops are good and hard times not felt, doing the best business outside of Chicago. Population 12,000. Capital required about \$8,000; annual cash sales \$35,000. Investigation courted. Best of reference given and required. Prefer young man of some experience. Address F. E. B., care JEWELERS' CIRCULAR.

## For Sale.

**FOR SALE**—Fine electric engraving machine. Cost \$160. Will exchange or sell cheap. Make me offers. L. E. Hubbard, Park City, Utah.

**THREE** 10-foot black walnut side show cases at \$50 each; a bargain. H. C. Kachlein, La Fayette, Ind.

**PAYING** jewelry business in live town established 20 years. No competition. Bench work alone pays \$50 monthly. Clean stock. Ill health reason for selling. Will sell for \$1,500 cash. W. C. Bailey, Winthrop, Me.

**FOR SALE**—One pair new power rolls, double geared, 4 inch flat, to be sold cheap. Apply to H. M. Ryman, 51 Maiden Lane, New York City.

**TRIAL SET**, 29 pair convex and 29 pair concave running from 2 to 180, fitted in fine morocco case. Perfectly new. Has not been used one month. Value \$40. Will sell for \$20. E. Shipley, Greencastle, Ind.

## ... WALL CASE ...

32 ft. long, cherry finish, doors slide up. Plate glass mirror in center, 36x66. Base with cupboard and drawers.

**APPLY TO**  
E. P. WHEELER, 204 Market St., Paterson, N. J.

## FOR SALE.

The entire Plant of H. Muhr's Sons' Factory; one of the most complete in this country will be sold for reasonable price. Bids solicited.

**BROAD AND RACE STS.,  
PHILADELPHIA.**

## MEDALS AWARDED



Providence Shell Works, Providence, R. I.  
Correspondence Invited

S

**SPECIAL**  
IN  
**THE JEWELERS'  
CIRCULAR**

Produce the  
results desired.

N  
O  
T  
I  
C  
E  
S

**HAGAN, WHITE & CO.,**  
MANUFACTURERS OF  
**GOLD AND SILVER MOUNTED CANES, UMBRELLAS & NOVELTIES.**  
RICH AMERICAN CUT GLASS, SILVER MOUNTED.  
248 WEST 23D STREET, NEW YORK.

### Deitsch Bros.' Notable Catalogue.

THE description of the catalogue of Deitsch Bros., manufacturers of silver mounted leather goods, which appeared recently in THE CIRCULAR but suggested the unusual beauty and completeness of the volume. It may be positively asserted that no work covering the same field of art industry has ever been issued to the

book form. Having thus conveyed a general idea of the appearance of the catalogue, a summary of its contents will prove interesting to all dealers in fine goods.

Plate No. 1 shows silver mounted card cases and tuck pocket books of seal, silver mounted; No. 2, pocket books in seal, silver mounted; Nos. 3 and 4, combination card cases and pocket books of seal, silver mounted; No. 5, the same articles in the famous "Morocco Ecrasé;" No. 6, card

15, silver plate mounted chatelaine bags of seal; No. 16, chatelaine bags of various leathers, with sterling mountings; No. 17, chatelaine and shopping bags of seal, plated mountings; No. 18, photograph frames and calendars of leather and silver combined; No. 19, exquisite sterling silver photo frames; No. 20, sterling silver letters and monograms; No. 21, the fashionable silver mounted ebony goods, with monograms, as brushes, mirrors, powder boxes, etc.; No. 22, same, whisks, manicure articles; No. 23, the same, in the beautiful Rococco pattern, toilet brushes, combs, etc.; No. 24, same in the Florence pattern; Nos. 25, 26 and 27, the same, in the delicate and pretty Majorie pattern, toilet and manicure articles; No. 28, same, desk requisites, as blotters, racks, rules, paper cutters, inkstands, etc.; No. 29, same, trays in various shapes, as eclipse, parallelogram, trefoil, heart, circle, kidney, etc.

The field of fancy has been liberally drawn upon for the beautiful designs, and the illustrations depict the highest class of workmanship. This volume which has been published in a limited number, will be sent to those dealers only who deal or desire to deal in the finest grade of silver mounted leather goods.

Orders of the Court in the Affairs of  
Simon Rumpf.

SEATTLE, Wash., Oct. 24.—Judge Langley has signed an order in the case of the Rockford Watch Co. *vs.* Simon Rumpf *et al.*, ordering the receiver, Arthur E. Griffin, to segregate from the stock of goods now in his possession all goods identified as consigned to Rumpf and agreed on between J. K. Basye & Co. and the receiver as having been so consigned, and to deliver them to the respective consignors on their paying their *pro rata* share of costs.

The receiver is also authorized to sell the remainder, together with the fixtures and furniture, to A. R. McOmber. The judge also makes provision for paying rent and clerical hire.

## CATALOGUE



Deitsch Brothers  
MAKERS

NO 7 EAST 17<sup>TH</sup> ST

NEW YORK

trade which has approached it in any and all the essentials of fine catalogue making. In its ensemble it is an achievement which may stand as a model.

The title page, of which a reduced representation is here given, is illuminated and is a chaste and attractive specimen of designing. The entire letter press of the pages is in photogravure of the highest class, there being 29 plates or leaves about 15x11 inches. These pages are bound within a stiff cloth cover of maroon tint, the front bearing in gold the trade mark of the firm. A ribbon attaches the leaves to the cover, though the volume is bound in

cases, in Brazilian and Java lizard, boa, and water snake skins, silver mounted; No. 7, white Morocco, silver mounted card cases, tuck pocket books, combination card case and pocket book, full dress card case, gentlemen's card case, address book, visiting book, ladies' pocket book, watch card case; No. 8, seal memorandum books, and letter cases silver mounted; No. 9, seal silver mounted cigar and cigarette cases; No. 10 silver mounted purses in various fancy leathers; No. 11, silver mounted spectacle cases, umbrellas straps and eyeglass cases; No. 12, seal portfolios; Nos. 13 and 14 desk pads, silver mounted; No.

## WE DESIRE TO INFORM

the Trade that on November 5, we will remove our

## DIAMOND CUTTING WORKS

TO

..... 45 JOHN STREET,

where, with increased and superior facilities, we feel confident of producing the  
BEST CUT GOODS at the LOWEST possible PRICES.

FACTORY:  
45 John Street.

ARNSTEIN BROS. & CO.,

OFFICE:  
37 Maiden Lane, N. Y.

## MATTERS IN JEWELRY STOREKEEPING.

That this department shall prove mutually beneficial to our readers, it is desirable that the members of the trade generally communicate with THE CIRCULAR regarding any advantageous device or plan that they are utilizing in the conduction of their business.

### Monitions as to the Show Window.

THE approach of the holiday season, when the jeweler will have goods to offer which appeal especially to the taste for luxury, suggests renewed attention to the subject of window dressing.

There can be no doubt that the show window is an admirable variety of advertisement, and it may be expected to pay for the attention required to properly manage it in almost any locality. It is safer to have no window rather than a poor or dirty one, and best to have one that will invite the wayfarer to drop in.

The dressing of a show window is always a matter requiring some mental as well as physical labor, but in the case of the jeweler, draperies and mirrors almost universally used, render the production of good effects less difficult than in most other instances. As to the treatment of that portion of the window which must depend for its attraction on other means, the monitions of this article are rather general than particular—to argue for attention to a form of advertising which always seems to need more or less recommending—a means of rendering the store attractive which too often suffers neglect.

Those who may feel that this argument applies to them will find the holiday season a good time to especially try their hands on the show window; and when they have done this we recommend them not to forget to keep on with the work; for a holiday window will not be appropriate after the season has passed, and the best kind of a window is the one which shows that its owner is very much alive and promptly moving with the times and seasons.

### Some "Striking" Rhymes.

CHRIS. PAPST, a Canadian jeweler, believes in advertising, and the following is a specimen of his ads.:

Strikes are all right if struck against wrong,  
Strike not the weak because you are strong;  
Strike not your father, strike not your mother,  
Strike not your sister, strike not your brother,  
Strike down a cheap scheme wherever you find it,  
Strike at all trickery, don't be behind it;  
Strike a hard blow when the iron is hot,  
Strike a deal with Chris. Papst and you'll strike the right spot.

### Pertinent Points in Advertisement.

Jeweler I. Loeb, Selma, Ala., has on exhibition at his store a handsome opera glass to be voted to the most popular lady, at the low price of 10 cents a vote. The proceeds will go to the united charities, this society being in need of funds.

\*

Julius C. Walk & Son, Indianapolis, Ind., excel in handsome window displays. Recently they showed a very beautiful variety of rich cut glass, displayed on black velvet ground and back-ground. Later these windows were quite as attractive in an artistic and effective display of choice pieces of art pottery and decorated clocks.

\*

L. Hahn, who recently opened a retail store in Westerly, R. I., on the opening day adopted a novel method of advertising himself and attracting trade. Every visi-

tor to the store on that day was permitted to vote for some club or society, and the organization that received the largest number of these votes was presented with a handsome silver ice pitcher. The scheme was highly successful.

### Revolving Display Stands.

JEWELERS are aware that a moving display in a window always attracts far more attention than would a similar stationary display. A moving display that can be made without dirt, bother or disarrangement of the window is one that the trade will certainly find effective for a holiday attraction and this may be achieved by the use of a special electric revolving show stand manufactured by Frederick Pearce, 77 John St., New York.

These stands are made to carry any number of shelves or in special designs such as obelisk or steeple shaped, which when covered with black velvet, are especially adapted for displaying diamond pins, necklaces and other jewelry. They are also made to carry a bust or figure of any weight from 1 to 50 pounds. Two cells of a battery and all the necessary material for charging are furnished with each outfit besides full instructions for setting them up. The batteries will run three months without recharging. Where the incandescent current is used they can be wound specially for it and can be started or stopped by turning a switch in the same manner as for an incandescent lamp. The latter method seems to be the best where the current is available.

Opal brooches are shown with the opal nearly three inches in their longest diameter.

# A MOVING DISPLAY

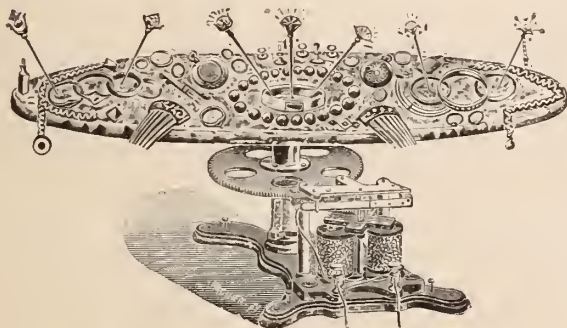

### FOR THE HOLIDAYS.

The Best Attraction in the World—a Moving Advertisement in a Window.

### OUR ELECTRIC REVOLVING SHOW STANDS

Are of various styles, made especially for jewelers. They are equivalent to a four fold increase of Show Window space. It runs steadily ten hours per day, at an expense of two cents per day. Made to be operated by either battery or electric light current.

Send for Circular of Illustrations.

FREDERICK PEARCE,

77 & 79 John St., N. Y.



SPECIALTY: SALES OF  
JEWELRY BRIC-À-BRAC  
AND  
ARTICLES OF VERTU

THE WESTERN TAKE ITS WAY

# WESTERN SUPPLEMENT

## of THE JEWELERS' CIRCULAR

**Chicago Office: Room 517, Inter-Ocean Building.**

VOL. XXIX.

CHICAGO, WEDNESDAY, OCT. 31, 1894.

No. 14.

### Chicago Notes.

#### TRADE CONDITIONS.

Buyers in town making selections of Fall stocks last week were more numerous than for a long time past and many large bills have been sold. The shipping rooms of jobbing houses are busy and mail examiners report orders more plentiful than for many months. This, they claim, is largely due to the fact that dealers are now receiving the Fall catalogues of the jobbing houses. After the elections have passed the trade look for a whirlwind of mail orders and business may already be said to be fairly launched on the sea of active operations. It were difficult to separate the various branches of the trade, all lines having shown a satisfactory increase.

M. A. Mead returned early the past week from Denver, Col.

M. Eisendrath, St. Louis, was numbered among the visitors here last week.

M. V. B. Elson, Freeport, Ill., has returned from a buying trip to New York.

Manager Loeb, of the Wadsworth Watch Case Co.'s Chicago office, left Thursday for principal western cities.

Mr. Katlinsky, of Katlinsky & Gatzert Co., is in Missouri with full jewelry and tool and material lines of the house.

E. D. Bardley, Harvard, Ill., will remove from his present store owing to damage resulting from lack of necessary repair to the building.

King & Co., have purchased the business of Smith & Newell, Harvard, Ill. It is understood the members of the new firm are Chicago men.

S. N. Jenkins, for Aiken, Lambert & Co., has returned from northern Illinois and southern Wisconsin with reports of good business in both States.

The Weber Co., jewelry dealers, have made an assignment to Thomas H. Brown, who gave \$5,000 bonds with A. L. Grootemat and James H. Moan as sureties.

The Rogers Park Silverware Co., of Chi-

cago, have incorporated with a capital stock of \$25,000. Incorporators, E. A. Barklew, Henry N. Frisbie and G. H. Lochr.

The junior member of J. Beale & Son, Rockford, Ill., enjoyed the week on a hunting expedition at Wisconsin lakes and woods. Albert E. Henry was also absent on a similar Wisconsin trip.

S. Goldsmith, of Goldsmith Bros., assayers and refiners, 67, 69 Washington St., returned Wednesday from California, after a month's trip. Trade on the coast, for a long time quiet, is reported to be now picking up.

O. G. Bryant has sold his flat building on Flounoy, near W. 48th St. on very favorable terms, \$3,500 cash. Mr. Bryant will shortly open a store near his old location on W. Madison St. for the purpose of reducing his jewelry stock, now in storage.

A. L. Smith, Geneva Optical Co., returned Monday from a ten days' trip to Geneva, N. Y., and the east. The factory is running full tilt and the company are over-run with orders, with a daily mail adding to these in a manner simply astonishing.

Jewelry engravers formed an association last week for the purpose of upholding prices for work and for the welfare of the trade. Twenty-two representatives of the largest business houses in the city met at the Great Northern Hotel and elected the following officers: M. D. Stecker, president; W. H. White, secretary; E. B. Bowden, treasurer. The association will be known as the Chicago Engravers' Association.

The meeting of the Jewelers' Council, National Union, Oct. 20, was well attended. Applications for membership were received from E. G. Smith, C. E. Tollefson and P. J. Hauswith. A series of dancing parties is in contemplation, having passed by a vote of the council. At the close of the session adjournment was had to the banquet room and refreshments partaken of, the entertainment concluding with singing, speech making and sleight of hand performance, which were thoroughly enjoyed.

The Massachusetts Society in Chicago will have luncheon and stereopticon enter-

tainment at the Grand Pacific Nov. 13. Among the members of this social organization are manager T. H. Purple, of the Holmes & Edwards and Manhattan Silver Cos., who is also a director of the society; Grove Sackett, manager for Wm. L. Gilbert Clock Co. and president of the Chicago Jewelers' Association; J. F. Talbot, manager of the Dennison Mfg. Co.; F. L. Merrick, Bradley & Hubbard Mfg. Co.; and John Gately.

Buyers in town last week looking forward to the trade of the holiday and Fall season included: L. H. Bauer, Elgin, Ill.; J. G. Bodenschatz, Lemont, Ill.; Geo. F. Beach, Valparaiso, Ind.; F. G. Bander, Elburn, A. Brown, Momence, Ill.; F. E. Burrigge, Erie, Ill.; O. V. Berry, Bismarck, N. D.; F. A. Bartlett, Lockport, Ill.; J. W. Burkitt, Arlington Heights, Ill.; The Chilton Jewelry Co., Braneville, Mo.; H. B. Clark, Rantoul, Ill.; W. W. Denny, Aurora, Ill.; W. D. Emerson, Aledo, Ill.; W. E. Southart & Co., Prophetstown, Ill.; Eggerman & Son, Aurora, Ill.; L. O. Gale, Mitchell, S. D.; F. Hoefer, Aurora, Neb.; J. F. Ingall, & Son, Waukegan, Ill.; Lyon & Kylling, Danville, Ill.; L. Luchtemeyer, Blue Island, Ill.; Albert Miller, Dundee, Ill.; E. Munson, Mendota, Ill.; W. R. McDowell & Co., Highmore, S. D.; D. O'Hara, Ottawa, Ill.; John Olson, De Kalb, Ill.; C. J. Petersen, St. Charles, Ill.; M. Putney, Ottawa, Ill.; W. A. Pratt, Pawpaw, Ill.; A. C. Parno, Greene, Ia.; J. W. Spence, Racine, Wis.; Mrs. F. J. Reemer, South Chicago, Ill.; Smyth & Lawrence, Elgin, Ill.; J. M. Scribner, Jr., Attica, Ind.; J. R. Scheider, Evanston, Ill.; R. Taussig, Washington Heights, Ill.; Mrs. P. M. Ward & Son, Arcola, Ill.; R. E. Winter, Ft. Sheridan, Ill.; H. J. Welch, Goodland, Ind.; C. J. Warner, Prophetstown, Ill.; W. P. Yeoman, Waukegan, Ill.; J. H. Allen and wife, Marseilles, Ill.; Richards & Park, Colorado, Tex.; H. A. Camp, Milwaukee, Wis.; J. H. Robertson, Morrison, Ill.; Julius Kahn, A. J. Kahn, Appleton, Wis.; I. J. Heath, Lansing, Mich.; I. J. Hayes, Austin, Minn.



# LOOK AT THESE PRICES!

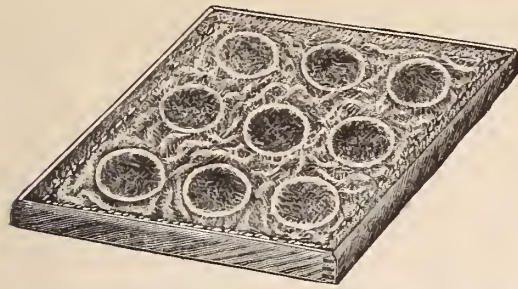

Show Case Trays with Solid Walnut Frames lined with Fine Red Silk Plush, with Old Gold Border, and made to stack one on top of the other. Size, 11 3/4 x 11 3/4.

For Gents' Watches, each . . . . . \$1.25  
For Ladies' Watches, each, . . . . . \$1.25  
For Rings, each . \$1.25. For Chains, each, . \$1.25  
For Charms, ea., \$1.25, for Card Jewelry, plain, ea., 80c.

Subject to the usual discount for cash.

## CHRISTMAS IS COMING.

Make your Stock Attractive and Fresh. It does not cost much and will add largely to your SALES.

## BENJ. ALLEN & Co.,

141 & 143 State St.,  
CHICAGO, ILL.

WATCHES, CLOCKS,  
DIAMONDS,  
SILVERWARE  
and JEWELRY.

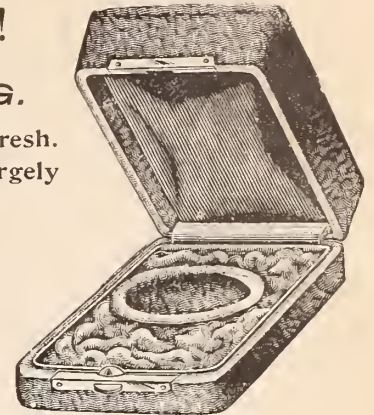

FINE PLUSH BOXES.

For Gents' Watches, per dozen, \$3.00 For Ladies' Watches, per dozen, \$3.00  
For Rings, per dozen, \$2.00 For Ear Drops, per dozen, \$3.50  
For Six Tea Spoons, per dozen, \$9.00 For Six Table Spoons, per dozen, \$15.00  
For Child's Set, per dozen, \$9.00 For Six Coffee Spoons, per doz., \$15.00  
For Sugar Shell, per dozen, \$9.00 For Butter Knife, per dozen, \$9.00

Subject to the usual discount for cash.

## 17 Jewel Dueber-Hampden Watches

ARE THE MOST RELIABLE WATCHES MADE.

A FULL LINE OF DUEBER CASES AND HAMPDEN MOVEMENT.

Write for New Price List.

**Brethauer Watch and Jewelry Co.,** Special Agents,  
71 WASHINGTON ST., CHICAGO, ILLS.



One of the best of the very best.

QUALITY IS THE STANDARD OF VALUE  
FOR WHICH WE COMPETE  
"THE MOSELEY."

"A Bread Winner" for the watchmaker. We furnish you good lathes and chucks, while the other fellow furnishes the wind.

MOSELEY & CO., Elgin, Ill.



No. 2 Moseley Wire Chuck has length, strength, accuracy.

EST. 1870.



DR. PETER HENRY  
SPECIALIST IN  
Watch Case Diseases

Key Winders changed to Stem Winders

Hunting Case changed to O.S.

English Case changed to fit American movements.

Can be cured at

53  
LONGWORTH ST.,  
Cincinnati, Ohio.

## G.A. WEBSTER

42 & 44 Madison St., Chicago, Ill.

Manufacturer,

AND WESTERN AGENT FOR  
E. G. WEBSTER & SON, of Brooklyn, N. Y.  
A. F. TOWLE & SON CO., of Greenfield, Mass.

No jeweler or watch repairer should be without a copy of "WORKSHOP NOTES," a new and very useful book for the workshop. Send for circular containing a complete index of the book, and judge of its merits for yourself.

## THE PLANCHAMP & BECKER CO.

Makers and Repairers of

### WATCH CASES,

Gold and Silver Plating

of Watch Cases a Specialty.

UNEXCELLED FACILITIES.

63 and 65 East Washington St., Chicago.

## PARSONS : SCHOOL

FOR

### WATCHMAKERS,

PEORIA, - - - ILL.

Send for Circular and Terms

## PARSONS & CO.



Little Late,  
About Nov. 1st.  
Wait for it Before You Buy.

This is our first Catalogue, nearly 500 pages. The reading on the cover explains all in a nutshell. If you are a practical Jeweler, or employ one, send us your address at once, and we will forward the book express paid. It will be dollars in your pocket. We give you this as our word, and our word is called good. All goods brand new, but the house was established in 1854. What we want are your mail orders; don't forget this.

G. W. MARQUARDT & SONS,  
Wholesale Jewelers, CHICAGO, ILL.

**WHAT**  
ARE YOU LOOKING FOR?  
QUICK SELLING GOODS?  
PROFIT MAKING STOCK?  
ORDER FROM  
**OSKAMP, NOLTING & CO.,**  
CINCINNATI, O.  
WE HAVE THOUSANDS OF NEW DESIGNS TO SELECT FROM.  
BE SURE AND GET OUR PRICES.  
CLOCKS AND SILVERWARE.

DIAMONDS.

WATCHES.

WATCHES.

NOVELTIES.

**Cincinnati.**

Lewis Ensey, Troy, O., is in Cincinnati taking the twenty-second degree of masonry.

Frank Herschede is making a fine display of Carrara marble pieces, which are much admired.

J. J. Davis, of Bedel & Co., Jackson, O., has been in Cincinnati several weeks learning engraving.

Oskamp, Nolting & Co. received Saturday a fine assortment of real tortoise shell hair ornaments, the prettiest ever seen in this market.

Eugene Swigart has left on an extended trip. John Swigart has just returned and reports an excellent business in materials, and an increasing demand for boxes and trays.

T. T. Kelley is a new traveler who will start out this week for O. E. Bell & Co. The Bell cases are having a good sized boom. They are becoming more popular every day.

Visitors in Cincinnati last week were: F. W. Ritchie, Piqua, O.; C. Helvey, Hamilton, O.; Chas. F. Held, Falmouth, O.; D. W. Brattin, Brazil, Ind. The latter is from a mining district, and reports business reviving. He will be in Cincinnati again before the holidays.

**Columbus, O.**

The Sutton jewelry store, in Stockport, was badly damaged by fire a few days ago. The firm carried no insurance.

M. Daniels, for six years in business on E. Long St., recently removed to a new room a few doors east of his former location.

O. S. Hofman, J. E. Howe, S. A. Hofman, Jacob Beelman and H. H. Beelman were last week granted articles of incorporation as the Hofman Supply Co., of Columbus, with a capital stock of \$25,000. The company will deal in watch makers' and jewelers' tools, materials and supplies of all kinds and do watch and jewelry re-

pairing and engraving. O. S. Hofman is president and treasurer and J. E. Howe, assistant secretary.

Hon. Philip H. Bruck, receiver of the Columbus Watch Co., has filed a partial report. It shows the list of stockholders who have paid the 30 per cent. assessment, the same paid by them aggregating \$37,526.23. Other receipts were as follows: Interest on assessments, \$410.71; merchandise sale, \$38,046.92, and rent for July, August and September, making a total of \$75,889.57. The total expenditures are \$61,991.03, leaving a balance of \$13,808.54 in money in the bank.

**Benj. Allen & Co.'s New Fall Catalogue.**

THE handsome new Fall catalogue of Benj. Allen & Co., Chicago, is a veritable encyclopedia of latest designs and choice patterns in gold and silver wares of everything required by the jeweler. From cover to cover there is not a page without its interest to some dealer, and the manner in which the numberless articles are clearly presented shows a degree of skill in composition and a knowledge of the requirements of the jewelry trade that come only from thorough study of the wants of the trade, and a wide experience in filling those wants.

The volume opens with some five score pages of watches, including diamond deco-

rated cases, which are followed by page upon page of diamonds, finely shown in white on a black background. Rings, chains and jewelry follow in numberless designs and varied qualities—each quality, by the way, selling for exactly what it is, the goods having been thoroughly tested by the firm. These require 228 pages. Silver in sterling and plated wares take up 233 pages for the proper display of both hollow and flat ware, and it would require a special order to secure a clock not to be found on its 114 pages devoted to this branch.

The last department, optical goods, has long since passed from one of minor importance, and will be of particular interest to both old established optical houses and those who are contemplating adding this department to their store. Taken all in all, the new Fall catalogue is a manual of knowledge jewelers.

Benj. Allen & Co. have issued a separate catalogue for tools and materials, embracing 464 pages, which together with the 768 pages above noted give a total of 1,232 pages of valuable printed matter which, if you are a legitimate jeweler, is yours for the asking.

The post office and Thomas Reploge's jewelry store at Roaring Springs, Pa., were robbed Thursday night. The post office safe was blown open with dynamite, and 13,000 stamps, money orders and cash amounting in all to \$433, were stolen. A big haul of watches was made at the store.

WRITE FOR NEW CATALOGUE.



**Chicago Watchmakers' Institute,**

SUITE, 913 A MASONIC TEMPLE, Our New and Enlarged Quarters.

A Modern Trade School for the Watchmaker, Jeweler and Engraver.

**E. & J. SWIGART,**  
JOBBER OF TOOLS & MATERIALS.

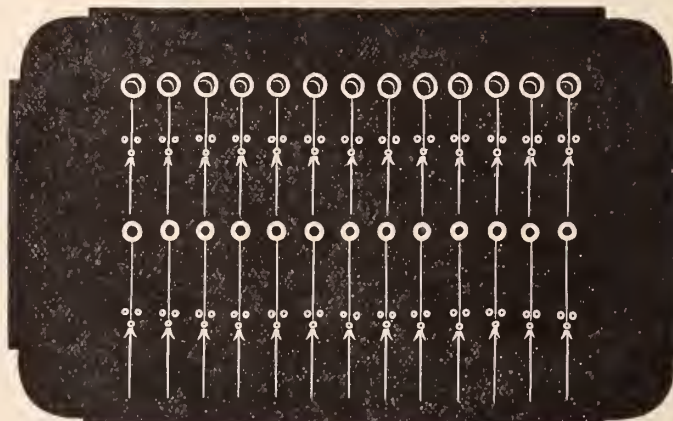

**14 K. Gold Watch Hands. QUALITY WARRANTED.**

The following Sizes in Stock.

18 Size, Waltham, S. W.	Htg.	Price per doz. pair, \$7.50	18 Size, Elgin, S. W.	Price per doz. pair, \$6.00
16 " " " "	" " " "	7.50	16 " " " "	" " " " 7.50
16 " " " "	P. S.	7.50	16 " " Int.	" " " " 7.50
6 " " " "	" " " "	7.50	6 " " S. W.	" " " " 6.00
0 " " " "	" " " "	6.00	0 " " " "	" " " " 6.00

14 K. Seconds to match, - Price per doz., \$2.50  
Send us your Material Orders, if you want good attention and prompt service.

101 WEST 5TH ST., CINCINNATI, O.

**GENEVA OPTICAL CO., CHICAGO.**  
CATALOGUES.

- PART 1—General Catalogue of Optical Goods.
- " 2—Microscopes and Accessories.
- " 3—Photographic Cameras, Stocks and Supplies.
- " 4—Thermometers, Barometers and Meteorological Instruments.

**PRESCRIPTION WORK** Made with Promptness and Accuracy.  
**OCULISTS' or OPTICIANS' OUTFITS.** Trial Cases, Ophthalmoscopes, Lens Measures.  
CORRESPONDENCE SOLICITED.

**San Francisco.**

J. H. Hoever, Willow, Cal., has been in town.

Ernest Block, representing W. & S. Blackinton, has been doing a good business in this city.

John Hammersmith, of Hammersmith & Field, has been taking a vacation in Santa Clara county with his family.

A. Houston, of the Spencer Optical Mfg. Co., New York, was here recently, and left for southern California.

Robt. Bonestell has left for the south, representing the California Jewelry Co. R. F. Allen has returned from the road.

Ott. Schwennicke, late of Lamos & Co., Chicago, has accepted the position with Nordman Bros., recently vacated by Gus Abrams.

A number of eastern travelers have been in San Francisco the past fortnight, A. Paul, representing E. I. Franklin & Co.; R. Wallace, R. Wallace & Sons Mfg. Co.; Chas. Gardner, Unger Bros.; Mr. Fielding, for A. Wittnauer, and Mr. Schwartzkopf, Bippart & Co., being among the latest.

**Pacific Coast Notes.**

Charles Noack, Sacramento, has been in San Francisco buying goods.

H. C. Hotfilter, Sacramento, has been in San Francisco on business.

James K. Bayse, jeweler, Seattle, Wash., has begun suit for divorce from his wife on the ground of intemperance and abusive conduct.

**Rockford, Ill.**

The Rockford Watch Co. are now running on full time.

A. Gunderson has purchased a building at Durand and will open a jewelry business.

The Rockford Watch Case Co. have just finished a contract for oxidizing in brass the metal trimmings for the interior of the new Second Congregational Church.

**Indianapolis.**

John Wimmer, optician, has remodeled his show window.

R. Miller, formerly with Wm. J. Eisele, is now connected with Heaton, Sims & Co.

Samuel F. Sipe, jeweler, Pittsburgh, Pa., has been visiting his brother, J. C. Sipe, at the Bates House.

S. J. Bradshaw, who recently sold out his Paris, Ill., jewelry store, is visiting relatives in Ohio.

C. E. Wasson, Thorntown, Ind., and Mr. Kersey, of Kersey & Campbell, Darlington, Ind., were in the city last week buying goods.

Heaton, Sims & Co. have been making some changes in their store room. The office has been moved from the rear to the front of the store.

The travelers for the Indianapolis jobbers left last week for their respective territories. D. J. Reagan, from Illinois, and Chas. W. Lauer, from Indiana, sent in some nice orders to Baldwin, Miller & Co. John Gardner visited western Indiana and Illinois trade for Heaton, Sims & Co. E. Sims, for the same house, found Indiana trade very good.

**Detroit.**

H. L. Baker, Reed City, Mich., has started a new jewelry store in the King block, in that place.

H. Loss, Wayne, Mich., purchased goods here last week. J. S. McLaughlan, Wyandotte, was also here.

The jewelry stock formerly owned by J. A. Jackson, Mancelona, Mich., has been consolidated with that of Herrick & Morse.

W. J. Higgins, Shelby, O., was recently in this city. He has purchased the jewelry business in that city which he sold to other parties.

Henry Wood, Leslie, Mich., who recently sold his jewelry business to Carl Newkirk, has again taken possession and will continue the same as heretofore.

Detroit jobbers last week closed out R. W. Macaulay, Ortonville, Mich., and Thomas E. Balkwill, Belding, Mich. The stocks will probably be brought to this city.

Dispatches to Detroit papers state that Geo. E. Johnston, jeweler, Lowell, Mich., was arrested last week in Grand Rapids, charged with taking undue liberties with eight-year-old Ethel Wingate, of Lowell. He says the charge is entirely untrue, and that the child is a notorious prevaricator. He alleges that it is a case of blackmail.

Carpenters last week commenced work on the new stores of F. G. Smith & Sons, recently vacated by Leonard & Carter, furniture dealers. They are located at the corner of Clifford St. and Woodward Ave. The partition between the two stores is being torn down, and, when finished, the firm will have the largest floor space of any house in Michigan or the west. They expect to get into their new quarters about Jan. 1.

One of the great needs of every well appointed dining table has been a carving knife sharpener. G.W. Marquardt & Sons, Columbus Memorial building, Chicago, will show in their new catalogue a sharpener that will not only sharpen the carver in one or two passes, but is also a handsome silver ornament to any table. The piece is illustrated, full size, in the new catalogue about to be sent out. The book contains many other novelties that will interest the jeweler and is being eagerly looked for by the trade as is shown from the fact that the firm are receiving applications for the work at the rate of 1,302 weekly.

**B**UILT FOR  
**U**SINESS

YES, THAT'S WHAT  
THESE PRICES ARE  
MADE FOR

**ELGINS REDUCED.**

THE FOLLOWING GRADES WILL  
BE CLOSED OUT AT PRICES  
QUOTED WHILE THEY LAST.



H. H. TAYLOR.

Compensation Balance, Breguet Hair-spring, adjusted, 15 Jewels (4 pairs setting), Patent Regulator, Hunting or Open Face.

- Gilded Movement, - - - - \$15.00
- Nickel Movement, - - - - 18.00
- No. 80. Gilt, Hunting, - - 15.00
- No. 76. Gilt, Open Face, - 15.00
- No. 33. Nickel, Hunting, - 18.00

**New 17-Jewel Elgin**

18-Size Movement.

B. W. RAYMOND.

Compensation Balance, Breguet Hair-spring, adjusted, D. S. Dial, 17 Jewels (4 pairs settings), Patent Regulator, Hunting or Open Face.

- Gilded Movement, - - - - \$28.00
- Nickel Movement, - - - - 32.00
- No. 70. Gilt, Hunting, - - 28.00
- No. 77. Gilt, Open Face, - 28.00
- No. 27. Nickel, Hunting, - 32.00
- No. 116. Nickel, Open Face, 32.00

Prices Subject to Catalogue Discounts.

**F. M. SPROEHNLE & Co.,**

CHICAGO.

PUBLISHERS  
OF **Our Salesman**

SEND AND GET OUR CATALOGUE.  
IT WILL PAY YOUR RENT.



## REORGANIZATION SALE OF Opera and Field Glasses.

We have for immediate sale the largest and best selected stock of Opera and Field Glasses in this country, and offer them at fully 25 per cent. below cost. A few specimen items:

- 75 Non-Achromatic Field Glasses**, 24 lines objective, in case,  
REGULAR PRICE, \$3.25, REDUCED TO.....\$2.00
- 50 Colmont Field Glasses**, 26 lines objective, in case,  
REGULAR PRICE, \$6.00, REDUCED TO.....\$4.90
- 85 Non-Achromatic Opera Glasses**, 15 lines objective, in case,  
REGULAR PRICE, \$9.00 per doz., REDUCED TO..... \$5.25 per dozen
- 50 Achromatic Opera Glasses**, leather covered and japanned, 15 lines objective, in case,  
REGULAR PRICE, \$1.75 each, REDUCED TO.....\$1.35 each.
- 50 Achromatic Opera Glasses**, leather covered and japanned, finer quality, 12 lines objective, in pocket book case, REGULAR PRICE, \$2.25 each, REDUCED TO.....\$1.55 each.
- 40 Achromatic Opera Glasses**, pearl covered, 15 lines objective, in case,  
REGULAR PRICE, \$3.75 each, REDUCED TO.....\$2.90 each.
- 36 Achromatic Opera Glasses**, pearl covered, 17 lines objective in case,  
REGULAR PRICE, \$4.50 each, REDUCED TO.....\$3.70 each

SEND FOR SAMPLES.

### QUEEN & CO., Opticians,

J. G. GRAY, Assignee.

1010 Chestnut St., Philadelphia.

SPECIAL SALESMAN OF

## WATCHES, DIAMONDS,

Bric-a-Brac

and Art Goods

FOR

Established Jewelers.

WRITE FOR PARTICULARS.

Communications Strictly Confidential.

References given in all parts of the United States from Retailers and Jobbers.



The Best  
Pin Vise  
Made.

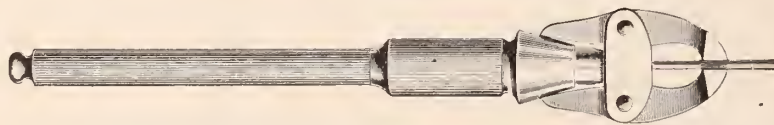

... Send to any Dealer or to THE LOWELL WRENCH CO., Worcester, Mass.

## THE IMPROVED RIVAL FOUNTAIN PEN.

Most reliable and guaranteed to give perfect satisfaction Over 75,000 in use.

Send for Price List and Liberal Discounts.



Export Trade Solicited.

D. W. BEAUMEL, 17 John St., N. Y., Inventor and Manufacturer. Repairing a Specialty. The Electric Stylographic Pen.

# MUSICAL BOXES

FACTORY AT AUBERSON, SWITZERLAND. ESTABLISHED 1828.

E. L. CUENDET, 21 John Street, New York City.

Send for our New Illustrated Catalogue for 1894, containing Full Particulars and Price Lists.

Fountain Pen 14 Kt. Solid Gold Net



**\$7.50** Net Cash  
DOZ. with Order.

Elegant Plush Lined Box FREE. Every Pen Warranted. Send for Catalogue.

DIAMOND POINT PEN COMPANY, 7 Astor House (Broadway), New York.



No. 3109. \$7.50 PER DOZ.

## COLLAR BUCKLE BROUCHES.

VERY STYLISH.

20 PATTERNS.

These Buckles can be attached to any collar as easily as a brooch and will be extensively worn this Fall and Winter. Made in Sterling Silver by

## CODDING BROS. & HEILBORN,

NORTH ATTLEBORO, MASS.

New York office, C. A. Vanderbilt, 178 Broadway, Chicago office, F. A. Buck, 103 State St.

H. M. RICH & CO.,  
Jewelry · Auctioneers,  
21 School Street,  
BOSTON, MASS.

## ONE TRIAL

OF OUR WORK ON REFINING OF ALL KINDS WILL CONVINCING YOU THAT OUR RETURNS ARE THE BEST



CONVINCE YOURSELF.

GEO. M. BAKER,  
Gold & Silver Refiner  
and Sweep Smelter,  
PROVIDENCE, R. I.

Queries by Circular Readers.

Editor of THE JEWELERS' CIRCULAR:

Being a subscriber to your valuable paper, I take the liberty to ask you to inform me, if possible, who the makers are of plated chains, stamped "A. F. & Co." on the swivel. As the stamp is close to the edge, it may be possible that it is "A. E. & Co.," but I think the first is right. S. J. SCHLESS.

ANSWER:—In all probability the stamp is of Albro, Eaton & Co., now S. Albro & Co., 61 Peck St., Providence, R. I. Albro, Eaton & Co. stamped A. E. & Co. on the swivels of their chains.

Editor of THE JEWELERS' CIRCULAR:

Would you please favor me with the address of the party that photographs souvenir buildings in silver trays, spoons, etc. I have seen some on the market, and should like to get the address of the party doing same. I have Leon Favre's address, but heard there is a party in New York that has a different process. WM. RETTENMEYER.

ANSWER: Wm. Barthman, 174 Broadway, New York, deals extensively in photographed souvenirs, and makes a specialty of photographs on silver and white metal trays. He has agents in a number of cities, and they are doubtless his productions you have seen.

Editor of THE JEWELERS' CIRCULAR:

Will you please give me the address of some reliable house from whom I can get the small mirror as described in article on Fall Productions in Silver Small Wares, page 22, issue of Sept. 26th, small plain mirror on one side with magnifying mirror on reverse side? Enclosed find subscription with enclosure of amount \$2 for one year beginning with Sept. 26th. The new novelties in issue of Sept. 26th make me feel that no live man should be without your paper W. H. REISNER.

ANSWER:—The firm making the mirrors you refer to is S. Cottle Co., 31 E. 17th St., New York, which is a reliable house.

Editor of THE JEWELERS' CIRCULAR:

One of my jeweler friends wishes to know the names and addresses of the manufacturers of cheap aluminum goods where he can have made one hundred thousand buttons for advertisements. If you will kindly forward to me this information, at your earliest convenience, I shall be pleased. DAVID E. MORTON.

ANSWER:—The Scovill Mfg. Co., Waterbury, Conn., we think will fill such an order.

English as She is Writ.

The following letter was received by a prominent silver house, and is given verbatim:

City of \_\_\_\_\_, Sept. 22nd, 1894.

.....

GENTLEMEN:

I am going to Organize a Whole-Sale Jewelry and Notion Establishment. Please send me a Catalogue of All the Good you manufacture so I can see your line of Good and Want to handle same.

Will you Please Send me the Name of any Mfg Factor of Brestpins, Color Button & etc.

if there a Mfg. of this Kind in your City send me name of Firm or any City you know of.

Except Many thank for Same.

Respt.

GEO. W. SMITH & CO.,

MAKERS OF

HIGH · ART · FURNITURE,

ESPECIALLY ADAPTED FOR

JEWELRY AND ART TRADE.

Cabinets, Pedestals, Jardineres Stands, Onyx Top Tables, 5 O'Clock Tea Tables, Curio and Souvenir Spoon Tables and Cabinets.

HALL CLOCK CASES.

FACTORIES,

3907-19 Powelton Ave., Phila.

NEW YORK SALESROOM,

818 Broadway, H. P. Vollmer, M'g'r.



KETCHUM & McDOUGALL, MANUFACTURERS GOLD & SILVER THIMBLES, GOLD COLLAR BUTTONS, AUTOMATIC EYE-GLASS HOLDERS 198 BROADWAY N. Y.

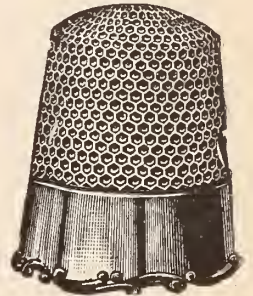

ILLUSTRATED CATALOGUE SENT ON APPLICATION

A Revolution in the Music Box Trade.



THE REGINA,

(Patented.)

It is an American music box, immeasurably superior in tone, execution and simplicity of construction to ordinary music boxes costing four times as much. By means of inter changeable metallic plates, obtainable at a trifling cost, it will play an unlimited number of tunes of every variety, including the latest operatic and popular airs.

Send for Illustrated Catalogue.

A. WOLFF,

194 Broadway,

NEW YORK.

CHRYSO-CERAMICS,

GOLD COVERED PORCELAIN.

M. & E. HEALEY,

1122 CONNECTICUT AVE.,

WASHINGTON, D. C

MEDAL AT WORLD'S COLUMBIAN EXPOSITION.

## Curious Timepieces of Former Centuries.

[BY GUSTAVE SPECKHART, IN DEUTSCHE UHRMACHER ZEITUNG.]

(Continued from June 13, p. 38.)

A QUEER case and clock is the so-called Zollern clock in the cathedral at Heilsbronn. To introduce the description with a short historical sketch: Heilsbronn is an old town, and lies near Nuremberg. St. Otto founded a monastery there

tery. To resume. The clock was built in 1513 and stood until 1866 in the monastery cathedral. It was then sent to the museum in Munich where it is shown as one of the curiosities of former centuries.

The illustration will sufficiently explain itself. Both lion and Death are of natural size, and carved of oak. The lion is still in the early Gothic style, He curves his back like a cat, in order to throw off the disagreeable rider on his back who, the right arm being movable, strikes a sound blow with the *tibia* upon his head, whereupon the poor animal issues a loud roar at every stroke of the hour. The rider Death is not in the shape as represented at present—a skeleton, but has sinews and muscles. This figure is gotten up admirably; it leans backward in order to strike a powerful blow with the bone. The lion's roar is produced by a metallic sheet fastened upon the head, by means of the stroke with his bone. The lion roars as often as is necessary to indicate the hours. The Death head opens the mouth every time a stroke is imparted, the lower jaw dropping downward and then shutting again.

The part of the clock case with this strange rider is simply a box embellished in Gothic style and suitably ornamented. Upon it, behind the lion, stands the actual clock case with dial. The front of the case behind the lion has a barred hole which has doubtless been cut in afterward for the better observation of the pendulum because it is almost certain that the old bar balance was replaced by a pen-

dulum. The clock movement is missing, but according to my opinion it was arranged as follows:

The frame as well as the train was of iron. Beside the going train the clock had an hour striking train; both were actuated by

weights. The case was sufficiently high to admit of them being placed within. The going train was calculated for 12 hours, like all the old clocks. The escapement was a verge with a horizontal bar balance to the saw like teeth of which small weights were hung for regulating the vibrations. The hammer arrangement of the striking train was connected with the movable parts of the figures; so that these were actuated at the striking.

## Workshop Notes.

**Equipoise.**—It is worthy of mentioning that a balance should not be equipped in the double califer, but in a good equipoising tool with well polished jaws.

**Tempering Cutting Instruments.**—When tempering cutting instruments, etc., it is necessary to thoroughly free the steel from the crust formed by forging; by this precautionary rule a very high degree of temper can be imparted, and this with a degree of heat inferior to that necessary if said rule has not been observed, because the hardening operates stronger and more uniformly on the bright steel than on the crust.

**Hardening Punches.**—When punches are to be hardened, which are for the purpose of being driven into steel matrices, they must be hardened until annealed blue; then rubbed with the fatty part of a beef sinew until covered with a thick coat, which excludes the air from the steel and conveys it to the carbon, instead of withdrawing it. For the same purpose, either small pieces of carpet or wool are to be laid upon the fire. The gases covering the body are permitted to develop fully, and when it has become sufficiently cherry red, it is dipped into cold water, which has previously been boiled and cooled again.

**The Barrel.**—When it is necessary to take down and repair the barrel, take notice of the following points: The side spring, which must not be too strong, should reach with certainty to the bottom of the space between the teeth of the ratchet, and this latter should be held steadily in position by the cap. The barrel may be made straight and true on its axis by the methods well known to repairers, the arbor having been previously put in order, if required. It is a good plan after making extensive repairs, to again test the barrel and center pinion depth, either by touch or by drilling a hole for observation. The screw of the female stop (star wheel, Maltese cross, etc.), must not project within the cover nor rub against the dial; it must be reduced if either case presents itself. The action of the stop work must be well assured, especially when the actual stop occurs; it is a good plan to, as it were, "round-up," the star wheel and finger-piece with an emery stick, supporting them on arbors. There must be no possibility of friction between the finger and the bottom of the sink.



THE ZOLLERN CLOCK AT HEILSBRONN.

in 1132, and even before this event the village boasted of a small church containing the sepulchre of the first Zollern count—the ancestor of the German *kaisers*. These Zollern counts were, beside being highway robbers, also the protectors of that monas-

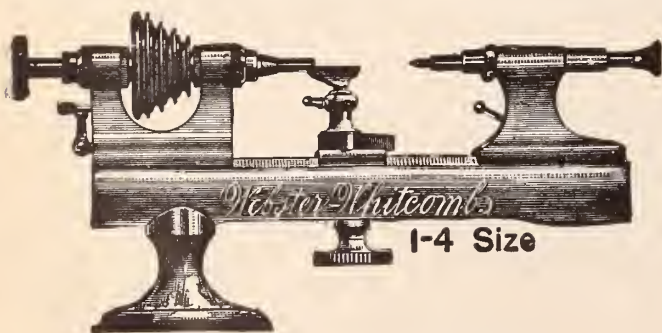

STRONGEST GUARANTEES.

Quality  
Maintained.

Prices to  
Suit the Times.

Ask for our New  
Prices and  
Terms for 1894.

American Watch Tool Company,  
Chymistry Dist., Waltham, Mass.. Stoney Batter Works.

**The Latest Patents.**

ISSUE OF OCT. 23, 1894.

**527,771. WATCH - MOVEMENT FRAME.**  
DUANE H. CHURCH, Waltham, Mass. — Filed May 26, 1892. Serial No. 434,444. (No model.)

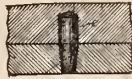

In a watch movement frame, the combination with superimposed arbor-supporting plates such as the upper and lower plates or the lower plate and the balance cock, of steady pins, removably secured to one of said plates and projecting from the inner side thereof, the projecting portion of each pin being tapering and entering a socket or orifice in the other plate, whereby the plates may be readily separated without liability of injury to the arbors, and attaching screws for holding the plates firmly assembled.

**527,772. WATCH-PLATE.** DUANE H. CHURCH, Newton, Mass.—Filed Jan. 25, 1892. Serial No. 419,251. (No model.)



The combination with a watch movement pillar plate having a case shoulder and having a recess of less diameter than the diameter of the pillar plate below the case shoulder, said shoulder being above the bottom of the recess of a dial fitted to said recess.

**527,786. SELF-WINDING ELECTRIC CLOCK.**  
EMIL G. HAMMER, Brooklyn, N Y.—Filed July 18, 1893.—Serial No. 480,825. (No model.)

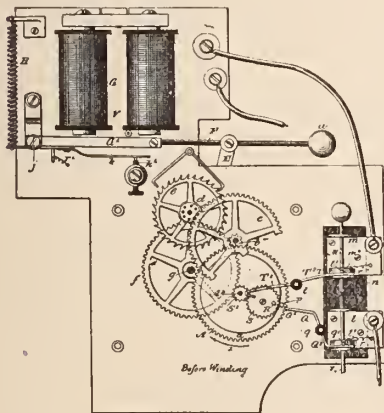

In a self-winding clock having an electric winding mechanism, a circuit-closer consisting of two movable contact terminals normally out of contact, a circuit-closing mechanism operated by the clock movement for closing said terminals together to start the winding, and a circuit-breaking mechanism comprising a wheel geared to the winding arbor of the clock movement and a connection from said wheel to one of said terminals for separating said terminals to break the circuit and stop the winding whereby the winding ceases upon the completion of a determined extent of winding movement.

**527,988. DIAL-SINKING MACHINE.** GEORGE E. HUNTER, Elgin, Ill., assignor to the Elgin National Watch Company, Chicago, Ill.—Filed Feb. 1, 1894. Serial No. 498,762. (No model.)

The combination of a work support, a tool, means for feeding the latter to its work, a stopping mechanism, and means controlled by the relative position of tool and work that set such stopping mechanism in mo-

tion before the work of the tool is to be stopped, whereby the operation of the tool may continue for an

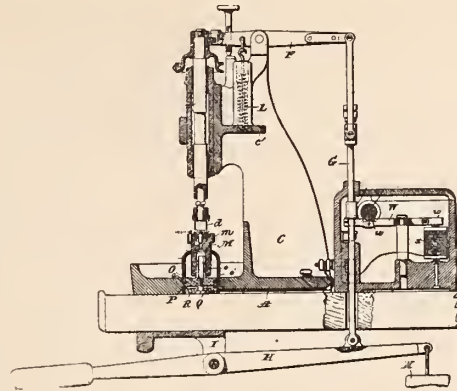

interval after said mechanism has been put in motion.

**527,999. FRUIT-HOLDER.** THOMAS LEACH, Taunton, Mass., assignor to the Reed & Barton Corporation, same place.—Filed April 4, 1894. Serial No. 506,332. (No model.)



The fruit-holder herein described, consisting of a receptacle for fruit having in its inner walls rigid vertical ribs *a* extending from the top to the bottom, and having a series of downwardly projecting ratchet teeth formed along their entire length.

**528,068. SPECTACLE-CASE.** GORDON W. BEGOLE, Stony Creek, assignor to Elijah A. Darling, Willis, Mich.—Filed April 28, 1893. Serial No. 472,151. (No model.)



A case for spectacles, consisting of a flat non-yielding integral block, having a cut out flat chamber in its center, open at one end and closed at the opposite end, a relatively narrow groove in one of its sides, of a length less than the length of the chamber, and a narrow closing strip for the groove formed separate from the block, secured to the case.

**DESIGN 23,716. STICK OR SCARF-PIN.**  
EDWARD B. THORNTON, Providence, R. I.—



Filed Aug. 17, 1894. Serial No. 520,631. Term of patent, 3½ years.

**DESIGN 23,717. SPOON, &C.** WILLIAM C. CODMAN, Providence, R. I., assignor to the Gorham

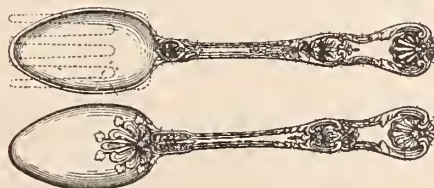

Manufacturing Company, same place.—Filed Sept. 28, 1894. Serial No. 524,403. Term of patent, 14 years.

**DESIGN 23,718. HANDLE FOR SPOONS, &C.**  
GILBERT L. CROWELL, Jr., Arlington, N. J.

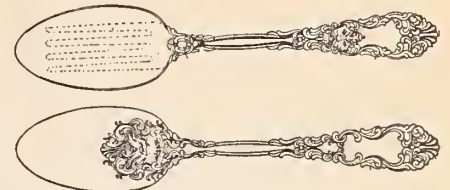

Filed July 23, 1894. Serial No. 518,399. Term of patent 14 years.

**DESIGN 23,719. HANDLE FOR SPOONS, &C.**  
LOUIS R. HORTON, Providence, R. I., assignor



to the J. B. & S. M. Knowles Company, same place. Filed Aug. 17, 1894. Serial No. 520,632. Term of patent 7 years.

**DESIGN 23,720. HANDLE FOR FORKS, &C.**  
CHARLES OSBORNE, New York, N. Y., assignor

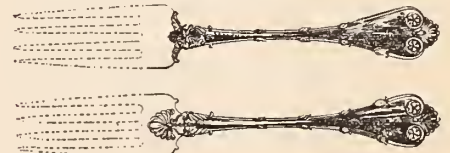

to the Whiting Manufacturing Company, same place. Filed Aug. 7, 1894. Serial No. 519,698. Term of patent 7 years.

**DESIGN 23,723. CLOCK-CASE.** JOHN HOPSON, Jr., New London, assignor to the Waterbury

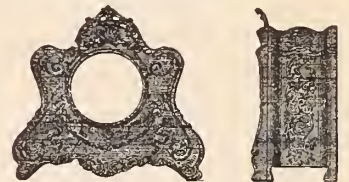

Clock Company, Waterbury, Conn. Filed Sept. 25, 1894. Serial No. 524,113. Term of patent 7 years.

WHITE'S EYE SHADE. **W. B. WHITE & SON**  
MANUFACTURERS OF  
Spectacle and Eye Glass  
CASES  
90 SOUTH STREET, BOSTON.

Special Cases made to order for Optical Trade. Cases for Trial Lenses. Opera Glasses recovered, etc. Chatelaine Spectacle Cases Metal Bound Leather Cases for combs, scissors, etc. Over forty kind of cases manufactured.

**WOOD & HUGHES,**  
STERLING SILVERWARE MANUFACTURERS  
New York Agents for the Derby Silver Co.'s  
FINE QUADRUPLE PLATED WARE,  
No. 16 JOHN STREET, NEW YORK  
206 Kearney St., San Francisco, Cal.  
HASKELL & MUEGGE, Agents.

**Jules Jürgensen**  
OF COPENHAGEN.

The reputation these watches have maintained for Fifty Years has never been equalled, being made on strictly scientific principles and no expense spared to give the Best results in mechanism and timekeeping qualities.

SOLE AGENTS.  
**John C. Hyde's Sons,**  
NO. 22 MAIDEN LANE.

DESIGN 23,721. CLOCK-CASE. JOHN HOPSON, Jr., New London, assignor to the Waterbury

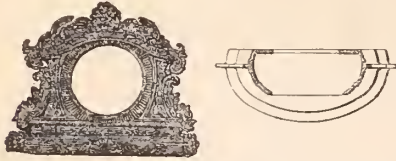

Clock Company, Waterbury, Conn. Filed Sept. 25, 1894. Serial No. 524,114. Term of patent 7 years.

DESIGN 23,727. GLASS VESSEL. HERMANN

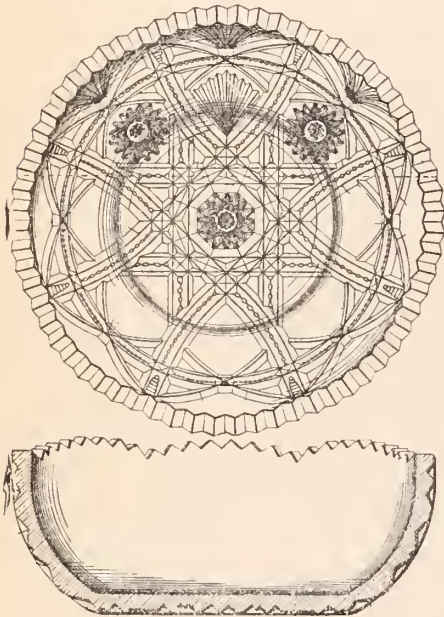

SIEGEL, New York, N. Y. Filed Sept. 24, 1894. Serial No. 523,983. Term of patent 7 years.

TRADEMARK 25,402. MECHANISM AND MATERIALS FOR WATCHES AND CLOCKS. HAMMEL, RIGLANDER & Co., New York, N. Y. Filed Sept. 22, 1894.

“UNICUS”

Essential feature.—The word “UNICUS.” Used since May 1, 1894.

Trade Gossip.

Do you look over L. Tannenbaum & Co.'s stock when you want anything in diamonds, colored stones and melles? You should do so.

Bates & Bacon report an excellent trade in their new Royal 14 karat goods. A new pattern just added is a six-size star and ver. in the Puritans.

R. L. Griffith & Son, Providence, R. I., have just added 12 new designs in their popular fancy figures. The line has proved very successful. The trade is reminded of the fact that this firm is the exclusive owner of the celebrated Golconda Gem line, mounted in studs, scarf pins, &c., in solid gold and plate. Each card and tissue on the genuine goods bears the words, “The Golconda Gem, Reg'd.”

One of the surprising features of the present general revival of business is the unexpectedly large demand for the finest and most expensive classes of goods. Among the manufacturers who have been able to take advantage of this demand to its fullest extent, is the John A. Riley & Sloan Co., 860 Broadway, New York, who in their new lines of gold and diamond mounted belts and hair pins, have introduced some of the richest and most artistic articles ever put before the jewelry trade. Among their latest designs in belts are those in which the openwork buckle surrounds a plain gold plate on which the wearer's initials are supposed to be engraved. Another design has as a centre detail, a gold network in which, at each crossing of the strands, is set a diamond, emerald or ruby. The extent of the variety may be judged by the range in the prices of the pieces, from about \$25 to \$500. A glance at the line of hair pins, mainly shell mounted in gold and set with diamonds, discloses the fact that the fashion is running to large pins, some of the newest being 2½ and others even 3 inches wide.

In the majority of these as well as the belts every junction of the gold scroll is set with diamonds and sometimes with pearls.

We are in receipt from the Pairpoint Mfg. Co., New Bedford, Mass., of two beautiful catalogues, one devoted to the silver and gold plate productions of the Pairpoint Mfg. Co., and the other to the rich cut glass and fine decorated art goods of the Mt. Washington Glass Co. The former contains 200 pages, 13x10 inches, and the latter 60 pages of the same size. One page shows the factory of the Pairpoint Co., the buildings being 1,200 feet long, 40 feet wide, representing a floor space equivalent in area to about 4½ acres. The larger volume illustrates and describes about 250 classes of articles, comprehending perhaps everything made in silver plate. The arrangement is systematic and attractive, and any line of goods is readily found by means of a complete index at the rear of the volume. The prices are printed under each article. A feature of the book is the part devoted to Pairpoint 1880 flat ware, containing a complete price list of this branch of their business. Among the lines illustrated are noted numerous novelties that must prove quick sellers. The volume in every respect is up to date, and should be in the hands of every dealer. The Mt. Washington catalogue illustrates the company's rich cut glassware in a most complete and attractive manner. Pages are devoted respectively to salad, ice and nut bowls, berry bowls, nappies and berries, butter tubs, water jugs, flat celeries, carafes and decanters, handled claret jugs, champagne, claret and whiskey jugs, flower globes, ice cream trays, plates, olive dishes, spoon trays and pickle dishes, bon bon dishes, upright spoons and celeries, sugars and creams, knife rests and sets, mounted goods, stemware, etc., etc. A price list appears opposite each page of illustrations. This catalogue will prove of advantage to the jeweler who possesses a copy.

R., L. & M. Friedlander,



Are now located on ground floor of

30 Maiden Lane, N. Y.

IMPORTERS OF  
DIAMONDS.

WHOLESALE  
JEWELERS.

JOBBERS IN  
American Watches.

We have made great reductions in the prices of Watch Glasses.

SEND FOR PARTICULARS

SEND FOR OUR NEW CATALOGUE.



The material department of Benj. Allen & Co. Chicago, is rushed with orders.

If you need anything in safes and want a good one at a low price, send for a representative from Mosler, Bahmann & Co., 518 Broadway, New York.

"Business is right good with us," said A. C. Becken, jobber, 6th floor Columbus building, Chicago, "and shows a good improvement in all directions. For some months past we have had a large business."

Some beautiful things in toilet cutlery, silver mounted, are illustrated on the handsome page of the R. Wallace & Sons Mfg. Co., Wallingford, Conn. The reputation of this house is the highest.

If you haven't looked at the manicure sets in sterling silver and in tenth gold, now being shown by Foster & Bailey, you are losing an opportunity for profit. See the announcement on another page.

Oskamp, Nolting & Co., Cincinnati, O., are a week behind in their orders. They have the direct trade with the best jewelers of the country because they are popular with this class for fair dealing and good goods at profit sharing prices.

Schauweker & Chalmers, Chicago, report things better in jobbing watch lines, with a marked improvement in country, business. "We do not look forward for much of a boom," said the senior member of the firm, "but expect a fair business for the remainder of the year."

A new line of berry spoons and sugar shells shown by Simpson, Hall, Miller & Co., Wallingford, Conn., has in the bowl a silver bright cutting showing through the gold lining. It presents an attractive and artistic appearance and many orders are being received.

E. & J. Swigart, Cincinnati, O., are making a specialty of genuine Moseley, Whitcomb and Rivett lathes, which they are selling at very low prices. They also have secured an immense stock of trays, boxes, etc., which they will offer at prices that are bound to be snapped at. Some of the handsomest trays ever made are in this lot.

The Waite, Thresher Co., Providence, R. I., have struck another phenomenal seller in the cane pins now being made by them and on which a patent has been allowed. These goods are really most excellent, being miniature canes with solid silver and gold handles, chased and engraved, the canes enameled to simulate wood and the sharpened ferrule serving as the point. Every jobber will find these goods quick sellers.

The Holmes & Edwards Silver Co., Bridgeport, Conn., are stirring up things with their new "gold aluminum" line of flat ware. The metal is a new one, resembling gold, and the ware attracts at first sight. The pieces are of solid metal, free from all trace of the baser metal used in high class plated ware, and, having no plating, it is said it will never wear nor lose its beautiful color, and is easily cleaned. "Gold" ware is thus placed within the

reach of all in all pieces of table flat ware except knives.

Attention is called to the fact that arrangements have been made whereby S. F. Myers & Co., 48-50 Maiden Lane, New York, will hereafter carry in stock a full line and display samples of 1847 Rogers goods, and the Meriden Britannia Co.'s wares. As the New York office of the Meriden Britannia Co. is located on Fifth Ave. near 25th St., nearly two miles north of the wholesale jewelry district, and as Myers & Co. will have on hand a full line of these celebrated wares, this will be an accommodation to the retailer visiting New York.

The new Princeton movements should receive the attention of every live dealer who is looking for some good, reliable watch, which he can sell with satisfaction to his customers and profit to himself. They are beautiful in model, artistic in finish and guaranteed accurate timekeepers, with prices which make them attractive to buyers. The time has come when retail jewelers for self-preservation are obliged to sell watches with which they are not brought into competition with persons outside the trade. Princeton watches offer this advantage.

The following letter received by the Spencer Optical Mfg. Co., 15 Maiden Lane, New York, serves to show the prompt methods of this company in filling prescription orders:

GLENS FALLS, N. Y., Oct. 16, 1894.

Spencer Optical Co.,

GENTLEMEN—The receipts sent you Friday night from here, and received by you Saturday morning, were back here Monday morning early, showing that in the space of a few hours you had attended to my orders and returned them on their homeward journey.

As the customer came from a distance of 30 miles to be fitted and had to wait for the glasses, you can readily judge how gladly the surprising short time it took to fill the complicated receipt made her. She desires to express her thanks, which I now do, and add mine for all they are worth.

Truly yours, L. P. JUVET.

Hardinge Bros., 1036 Lincoln Ave., Chicago, have doubled their capacity for chucks, the celebrated "Dale" being responsible for the increase. The brothers have a perfect plant, and are progressive young men of high degree of mechanical skill, as is shown in the fact that all the machinery of the plant, automatic and otherwise, is the product of their personal labor. "The 'Dale flat faced chuck,'" say the Messrs. Hardinge, "is the only scientifically designed chuck in the market. It possesses every advantage of the round faced with many that that does not, principally among them the fact that by bringing the bearing immediately under the head the tendency of springing is entirely eliminated—a main desideratum in a good chuck." Novelties of great utility being placed in the market by this factory, include a new carborundum grinding wheel, two new balance chucks—one for holding complete and the other for holding staff, without removing the roller—also a new stepping device constructed on scientific principles.

# Novelties .. IN .. Diamond Jewelry

.. FOR ..

## FALL SEASON, 1894.

RINGS, STUDS,  
LOCKETS, BROOCHES,  
LACE PINS, SCARF PINS,  
EAR RINGS, EAR STUDS,  
BRACELETS, NECKLACES,  
CORSAGE PINS,  
VICTORIAS,  
CHATELAINES,  
LINK BUTTONS,  
SLEEVE BUTTONS,  
COLLAR BUTTONS,  
CZARINAS, Etc., Etc.

Having imported a large reserve stock of Diamonds, we will not advance any of our prices at present. Dealers making their selections now will have the full advantage of the low tariff prevailing on Diamonds before the Wilson Bill went into effect.

Our stock of mounted goods is unusually complete.

You can save 15 per cent. by buying your Fall Stock now.

Write for a Selection Package.

## Cross & Beguelin

Loose—DIAMONDS—Mounted.

17 Maiden Lane,  
New York.

43 RUE MESLAY, PARIS.

### The Chambered Nautilus.

MANY admirers of the poems of the late Oliver Wendell Holmes think that "The Chambered Nautilus," which follows, is his best poem:

This is the ship of pearl which poets feign  
Sails the unshadowed main;  
The venturous bark that flings  
On the sweet Summer wind its purple wings  
In gulfs enchanted, where the siren sings  
And coral reefs lie bare;  
Where the cold sea-maids rise to sun their streaming  
hair.

Its webs of living gauze no more unfurl;  
Wrecked is the ship of pearl.  
And every chambered cell  
Where its dim dreaming life was wont to dwell  
As the frail tenant shaped his growing shell  
Before thee lies revealed.  
Its irised ceiling rent, its sunless crypt unsealed.

Year after year beheld the silent toil  
That spread his lustrous coil;  
Still, as the spiral grew,  
He left the last year's dwelling for the new,  
Stole with soft step its shining archway through;  
Built up its idle door;  
Stretched in its last found home and knew the old no  
more.

Thanks for the heavenly message brought by thee,  
Child of the wandering sea,  
Cast from her lap, forlorn!  
From thy dead lips a cleaner note is born  
Than ever Triton blew from wreathed horn!  
While on my ear it rings,  
Through the deep cares of thought I hear a voice that  
sings:

Build thee more stately mansions, Oh, my soul,  
As the swift seasons roll!

Leave thy low-vaulted past!  
Let each new temple, nobler than the last,  
Shut thee from heaven with a dome more vast,  
Till thou at length art free,  
Leaving thine outgrown shell by life's unresting sea!

### Pearls Made to Order.

IN an entertaining paper by A. J. Gibbins on "Curiosities of Pearls," in the *Gentleman's Magazine*, this striking incident in pearl making is recounted: "An extraordinary treasure illustrating the successful manner in which these precious gems can sometimes be produced by the 'strategical process,' was lately shown by the Smithsonian Institute. This was a pearl the size of a pigeon's egg, of an exquisite rose color, and the receptacle containing it was the original fresh water mussel in which it had been formed. The nucleus of this wonderful stone was nothing more nor less than an oval lump of bee's wax, which had been placed and left for a few years between the valves of the mollusk which had at once proceeded to coat it with the pink nacre it secreted for lining its shell. The mussel was kept in an aquarium while engaged in its lengthy task. It belonged to a species common in American rivers, and it is suggested that the result of the experiment opens to everybody the possibility of establishing a small pearl factory for himself by keeping a tank full of tame mussels and humbugging them into making 'great pink pearls' for him."

### The Other Side of Life.

LUCKY.

With dress suits they don't wear watches;  
And Augustus thinks that's prime,  
Because he never can manage  
To have both at the same time.

—Judge.

"I never heard such a girl for preaching punctuality," said Maud.

"It's a positive mania with her," replied Mamie; "yesterday she had the clocks taken out of her stockings because some one told her they were fast."—*Life*.

NO OCCASION FOR FORMALITIES.

"Is this your umbrella, sir?" inquired the stranger in the brown suit, hurrying after the stranger in the drab suit, who had just got off the train.

"My dear sir," answered the other, "there need be no formalities in this case. We both saw it in the vacant seat at the same time. You got it first. I see it is a gold handled affair and I congratulate you. Good-day."—*Chicago Tribune*.

SHE—How dare you kiss me sir?

HE—I'm awfully sorry, but—why did you encourage me?

SHE—And pray sir, how did I encourage you?

HE—Well—you took off your glasses?—*Pall Mall Gazette*.

# The Best Chatelaine is the Lady Racine.

## STEEL CASES & SILVER CASES.



10 LINE.

Made in 10 Line Open Face.

“ 11½ Line Open Face and Hunting.

“ 13 Line Open Face and Hunting.

THE SILVER CASES ARE 0.935 FINE.

THE MOVEMENTS HAVE 10 JEWELS

THE ENGRAVINGS ARE CHOICE.



3 LINE

## MADE IN 12 LINE OPEN FACE.

In Silver Cases only.

Case 0.800 Fine with a 6 Jewel Movement.

Expressly Gotten Up to Suit the Times.

A GOOD Chatelaine Watch at a LOW PRICE.

Do not fail to ASK YOUR JOBBER FOR THE NEW  
12 LINE LADY RACINE in 0.800 Cases.



12 LINE

IN BRIC-A-BRAC,

Rudolstadt

Art Porcelain

FOR WHICH WE ARE  
SOLE AGENTS,

LEADS THE WORLD.

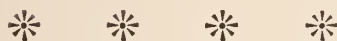

IT REPRESENTS MORE FOR THE MONEY, AND SELLS AT A BETTER  
PROFIT THAN ANY CLASS OF FANCY GOODS THAT CAN BE HANDLED.

A THOUSAND STYLES TO SELECT FROM.

SEE THAT EVERY PIECE IS LABELED:



L. Straus & Sons,

IMPORTERS AND MANUFACTURERS OF

CHINA, POTTERY AND GLASSWARE.

42, 44, 46 & 48 Warren Street . . . . .  
and 116 Chambers Street, New York.

# FERDINAND BING & Co.,

NEW YORK:  
106 GRAND ST.

PARIS:  
74 RUE D'HAUTEVILLE.

BERLIN, DRESDEN, VIENNA, ST. PETERSBURG, MOSCOW.

NOVELTIES IN ALL OUR WELL KNOWN LINES.

**New Goods. New Prices.**



A GROUP OF REPRESENTATIVE BRIC-A-BRAC IN OUR SHOW ROOMS.

## SPECIALTIES THIS SEASON:

RUSSIAN BRONZES, RUSSIAN ENAMELS, RUSSIAN LACQUERS,  
RUSSIAN NOVELTIES IN MALCHITE, LAPIS-LAZULI, QUARTZ, and PORPHYRY.

**CARVED IVORY STATUARY.**



### The Rambler's Notes.

WHAT THE RAMBLER SAW AND HEARD AMONG THE DEALERS IN ART POTTERY, CUT GLASS, BRONZES, ETC.

BRASS AND CUT GLASS.

**T.** B. CLARK & CO., 860 Broadway, N. Y., have a unique and most artistic combination of cut glass and solid cast brass work finished in matt and burnished gold effects. A special piece which will be illustrated in these pages shortly is a salad or fruit bowl in the handsome Bradstreet cutting. At the bottom of the bowl is a cylinder, also of glass, which fits snugly into a suitable socket in an artistic foot or pedestal of solid brass. These new bowls are now ready in 8 and 9 inch sizes, in combination with various patterns in bases.

POPULAR TERRA COTTA FIGURES.

**T**HE "Pickanniny Pair," here illustrated, are excellent representatives of the smaller pieces in the line of terra cotta figures carried by Levy, Dreyfus & Co., 11 Maiden Lane, New York. The pieces which stand about 8 inches high are



in natural colors. The workmanship is excellent and the details, as the facial ex-

pression, pose and other characteristics, are delineated with an exactness seldom seen in pieces of this kind. One of the merits of this line is that many of its subjects while thoroughly artistic, appeal to people of all tastes. There is in them the "touch of nature" which often does more to attract the buyer than does the artist's or the sculptor's skill. The line includes figures, single and in pairs, busts and groups, in sizes ranging from 6 inches to about 3 feet high.

RICH JEWEL GLASS.

**A** NEW assortment of jewel glass has been opened by Lazarus, Rosenfeld & Lehmann, 60 Murray St., New York. In flower tubes and vases the variety is now greatly enlarged, the new pieces adding much to the richness of the line. Rose color prevails in the finer new pieces which are vases, bottles, decanters and bon bon boxes especially. The greater number have appropriate rich gold ornamentations, while others have a decoration closely resembling white lace. Additions have also been made to the collection of vases and tubes with ring decorations. These are of plain, cut and corded crystal ornamented with one or more gold bands in which are set many different colored jewels.

AN UNUSUAL OPPORTUNITY.

**A**N opportunity to increase their holiday stock of art pottery at small cost is offered jewelers by Ach. & Chas. Gericot, 78 Murray St., New York. This firm are closing out their entire stock of Luneville (France) clocks, vases and jardinières, for which they are the sole agents in the United States. The trade will here undoubtedly find many bargains, as no reasonable offer for these goods will be refused.

RICH DESIGNS IN BANQUET LAMPS.

**A** VERY rich design in banquet lamps is the Rococo, which the Craighead Mfg. Co., 38 Park Place, New York, are about to introduce. As the name indicates, the style of the

heavy, rich stem and foot is distinctly rococo. It is finished in gilt and silver. In another new line of banquet lamps, the pieces have rich enameled bodies with gold and silver ornamentation on cast cupid heads.

ANTIQUE COLONIAL CLOCKS.

**T**HE introduction by the Chas. Jacques Clock Co., 22 Cortlandt St., New York, of reproductions of antique colonial hall clocks, as announced in these columns Sept. 19th, has already proved a successful venture. The cases which are ornamented with marquetry are of the color of antique mahogany and have the appearance of well preserved antiques. They are fitted with a striking or a special chiming movement controlled by this company. The illustration shows one of the designs which have proved most popular. It is simple, yet rich in appearance.

THE RAMBLER.

### An Exhibition of Ceramic Art.

**W**E lately availed ourselves of the courteous invitation which the Japanese Consul-General at Liverpool extended to us to inspect the lovely objects he has with such infinite pains collected, during many years, from every part of that strange land about whose warlike deeds so much is heard just now, says a writer in the *Pottery Gazette*, (London). Mr. Bowes' Museum is a world of delight, not to the scientific alone, but to all who love beauty of form and color and restful surroundings; and we could not help thinking what a world of information might be gleaned in a short time by our pottery manufacturers, especially those who are energetic enough to forsake stereotyped paths and are sufficiently far-seeing to seek



## The Connoisseur.

(Continued from page 49.)

newer thoughts. The cool, spacious rooms, spread with soft rugs, would be very inviting were no treasures of art to be explored. The whole history of Japan—and the history of a nation is best recorded by its arts and industries—is enclosed within these walls, and the effective method in which they are displayed is beyond praise. Every opportunity has been taken advantage of to render the collection of the greatest instruction to all who are intimately concerned in the ceramic manufacture, and the time and money which have been expended in the bringing together of such treasures can best be described as an ideal means for the acquisition by the community. As is well known, the HiZen ware was about the earliest pottery produced in Japan, and of this school there are many specimens of great value, among them pieces noticeable as being of the beautiful painted porcelain bearing the date 1504 A.D., some patterns of which clearly show the source from whence the famous Derby blue, red and gold decorations were derived. As was first observable in European pottery history, the initial productions of Japan are here shown to have been of white ware, the decoration in gold colors not being attempted in the early stages of the industry; still, only an inconsiderable period elapsed before their adoption,

as will be seen from the examples arranged in chronological order.

A decided feature of this age of the potter's art in Japan consists in the number of flower bowls of almost all sizes, many of which are of great beauty, not only as regards the shape, but also the decoration; particularly an oval and another a round one, the ornamentation being very unique. We also were much pleased with a hanging wall plate, perforated so as to show the exact shape of the daffodil flowers with which they were naturally painted; the delicate tinting of the flowers and foliage on the body was very praiseworthy. Tea bowls of all conceivable shapes and sizes from the Rakus period to the present time would be full of interest to the ceramic designer; our attention was drawn to one in a dark drab body with raised dragon ornamentation in gold, and colors, bearing date 1765.

The productions of another famed pottery, the Kaga, whose style of decoration is more familiar to Europeans, are to be found in the collection in great variety; they consist of two kinds, one, the most ancient, decorated in green, and the other first originated in the year 1706, when the pottery was ornamented so beautifully in red and gold. It would appear that the two styles we have mentioned were ultimately combined, forming the polychromatic style so largely used at the present time by Japanese potters.

The vases of this period are of great beauty, and show most decided novelty, both in shape and design; some of them, perforated, as is often seen in Worcester porcelain of modern times, would be found worthy of imitation by potters of the present day, particularly one covered with network, admirably portrayed in the body of the clay, with fish swimming behind, the latter being painted in the inimitable "blue poudre."

Perhaps the most valuable specimens in the collection to the student of pottery are the three slabs of porcelain, pieces of unusual size, without flaw or crack in the material or potting, and the decoration throughout being perfect in execution and color. They are painted to represent the three traditional dramas of that country.

Japanese pottery is also exhibited displaying every phase of the ware, including the inferior work recently made for export to Europe and America; although this description is not applicable to some of the imitations of early Satsuma ware manufactured in the province of Ota, nor to the beautiful ware known as Awaija faience, with its pendant fringes; to say nothing of the perfect vases in celadon china made in Tokio.

Manufacturers of pottery in this country will find it of inestimable advantage to spend a few hours in Mr. Bowes' Liverpool Museum of Japanese Art, where, too, they will find a most cordial and pleasing reception.

## There are few finer displays of Oriental Lamps

than that to be found "within our walls." The entire line is distinguished for novelty of design and artistic merit. Tokanabi lamps: library size, \$3.75 up; banquet size, \$6.50 up; floor size, \$27.50 up. Taizan lamps: library, \$9.00 up; floor, \$135.00. Ihrado blue and white lamps: Princess, \$1.75 to \$11.25; library, \$10.50 to \$25.00; banquet, \$12.50 to \$60.00; floor, \$90.00 to \$375.00. Japanese bronze lamps: library, \$14.50 to \$18.00; banquet, \$15.00 to \$75.00; floor, \$67.50 to \$100.00. Benares brass lamps: Princess, \$7.50 to \$16.50; library, \$25 to \$37.50; banquet, \$25.00 to \$125.00. These prices are subject to 25 per cent. discount on trade orders.



## A. A. Vantine & Co.

LARGEST IMPORTERS: JAPAN, CHINA, INDIA, TURKEY AND PERSIA.

Wholesale: 18, 20 and 22 East 18th St. Retail: 877 and 879 Broadway, N. Y.



# HINRICHS & CO.,

29 & 31 Park Place, N. Y.

## ART GOODS AND BRIC-À-BRAC.

CHINA LAMPS, FRENCH CHOCOLATE POTS,  
 CRACKER JARS, SOUVENIR CUPS, COMB  
 AND BRUSH TRAYS, FRENCH AND  
 BOHEMIAN BOUQUET HOLDERS,  
 CHRYSANTHEMUM VASES, CUT AND  
 ENGRAVED BOHEMIAN GLASSWARE,  
 DOULTON, ROYAL DRESDEN, ROYAL  
 VIENNA, TEPLITZ AND

ALL KINDS OF FANCY POTTERY.

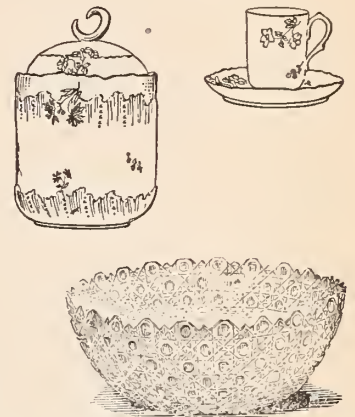

355 Mulberry Street.

IN GOLD AND SILVER.

Newark, N. J.

### BURGLARY INSURANCE.

### Fidelity and Casualty Co.

OF NEW YORK

INSURES Safes and their Contents

Against Burglary.

For Particulars, address the Company,

140-146 BROADWAY,

NEW YORK

## SOME \* NEW \* DEPARTURES.

AN AMALGAM Skeleton EYE GLASS made without drilling holes in the Lenses, stronger than any other style. Guaranteed not to come unfastened. Very neat



WE are the sole manufacturers of Opera Glass Holders in the United States, have added a number of new and desirable styles and made big reductions in prices. For sale by all leading jobbers.

AN "ANCHOR" Guard for Eye Glasses something new and practical. Cannot be shaken off. Made in all styles. Write for samples.

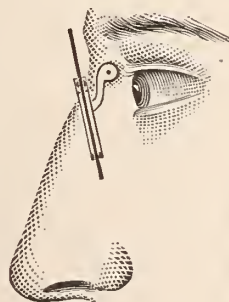

"KING'S ELITE" set of Test Lenses is the finest that skill and science can produce; has a number of new features.

WE are pleased to inform the Trade that R. H. KNOWLES, M. D., is now in our employ and has charge of our private instruction department. You can come to see us any time and get instructions, so as to be able to use our Elite Test Case and Optician's Outfit, and make your Optical business a big success.

OUR Jobbing Department has been increased and we can now do any kind of work and send it back to you by return mail. See new reduced price list. Write for clean charts, R blanks electrotypes for advertising and prices on our specialties.

### JULIUS KING OPTICAL CO.,

14 MAIDEN LANE, NEW YORK CITY,  
Diamond Exchange Building.

CLEVELAND, O. KANSAS CITY, MO.

**OPALS.**

**E. KIPLING,**

182 Broadway, New York.

ELEVATOR ENTRANCE, 2 JOHN ST.

**S. F. MYERS & CO.,**

Manufacturing and  
WHOLESALE JEWELERS,

1895 Issue, No. 39.

**OUR ROYAL CATALOGUE**

Illustrates all that is new, unique  
and desirable in

everything that pertains to jewelry  
Sent free to dealers. 600 pages, this size.

SEVEN DOUBLE FLOORS.  
TWENTY-TWO DEPARTMENTS.

Myers Buildings, 48-50 Maiden Lane,  
33-35 Liberty St., New York.



.. OUR ..  
**SPECIALTY**  
The Largest Stock of  
**CHIMING**  
AND  
**STRIKING**  
**HALL CLOCKS**  
ever shown.

**Chas. Jacques**  
CLOCK CO.,  
22 Cortlandt Street.  
NEW YORK.



**B. & W. B. SMITH,**  
220 W. 29th St., New York.

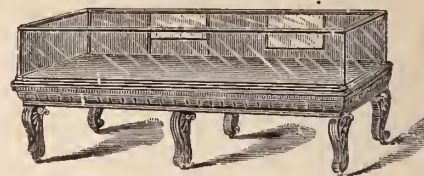

Improved Dust-Tight Counter Cases,  
Perpendicular Sliding Doors.

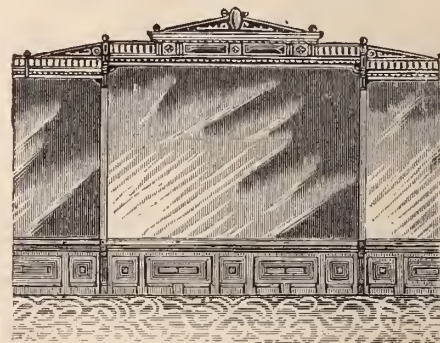

Improved Dust-Tight Wall Cases.  
Furnished with Improved Shelving and ar-  
ranged for Electric Lighting.

Sold by all whole-  
sale dealers at manu-  
facturer's price.

**A. N. CLARK & SON**  
PLAINVILLE  
CONN.

Manufacturer of the Celebrated  
**LOOP WATCH KEY.**

The Best for the Price in the World,  
CROSBY'S JEWELING TOOLS IMPROVED.

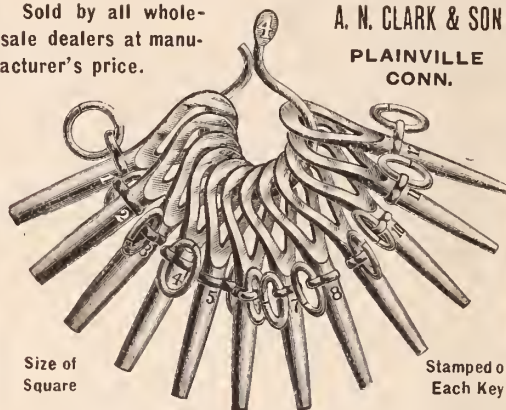

Size of  
Square

Stamped on  
Each Key.



Will quote royalty or price for the manufacturing of articles of real worth.

**L. LELONG & BRO.,**  
GOLD AND SILVER

**Refiners, Assayers AND Sweep Smelters,**

◇ SOUTHWEST CORNER HALSEY AND MARSHALL STREETS, ◇

**NEWARK, N. J.**

**SWEEPINGS A SPECIALTY.**



**U. S. SMELTING & REFINING WORKS.**

Sweep Smelting and Assaying. Platinum in Plate and  
Wire. Chemically Pure Copper. Ore and Bullion  
Assays a specialty.

Highest prices paid for old gold and silver.  
Sole manufacturers of Phoenix Flux  
and Eureka Alloy.

**M. WOLLSTEIN,** 25 John St., New York.

**Diamond Polishing Machines.**

We build these machines complete with latest improve-  
ments also polishing wheels, tongs, dousps, weights,  
shafting, belting, ventilating fans, gear-cutting, die blanks,  
etc., We do general repair work on jeweler's machinery.

**THE ARTHUR CO.,**

General Machine Works,

86 JOHN STREET NEW YORK.

**ALBERT LORSCH & Co.,**

37 MAIDEN LANE, NEW YORK.

Branch, 167 Weybosset Street, Providence. R. I.

IMPORTERS OF DIAMONDS,

Rose Diamonds, Rubies, Sapphires, Emeralds, Opals, Moonstones,  
Fancy and Imitation Stones, Novelties.

SOLE OWNERS AND IMPORTERS OF

*The Sumatra Gem.*

REG'D. UNEQUALLED IN  
BRILLIANCY AND  
HARDNESS

HIGHEST AWARD AT THE COLUMBIAN EXPOSITION, CHICAGO, 1893.

**IT PAYS** TO KEEP IN TOUCH WITH TRADE AFFAIRS. For 4c. a Week will do it. **Subscribe.**  
THE JEWELERS' CIRCULAR.

**DIAMONDS** Importers and Cutters. **L. & M. KAHN & Co.,** 172 Broadway, NEW YORK. **DIAMONDS**





Copyright by THE JEWELERS' CIRCULAR PUB. CO.

189 Broadway, New York.

Entered at the Post Office in N. Y. as second-class matter.

VOL. XXIX.

NEW YORK, WEDNESDAY, NOV. 7, 1894.

NO. 15.

## THE ART OF ETCHING ON SILVER.

**D**EACON Earle, of Tremont Temple Church, Boston, Mass., at the dedication of the corner stone for the new edifice, presented to Rev. Dr. Lorimer, the pastor, a silver and gold symbolic trowel, the gift of Reed & Barton, Taunton, Mass., to be used by him when laying the stone.

The blade of the trowel exhibits a remarkably fine specimen of etching, reproducing in accurate details the front elevation of the proposed new edifice. The work in every respect is commendable.

### Pearl Gathering.

**T**HE islands of Cubagua and Margarita were the principal seats of the pearl fishery, which was also carried on extensively in the Gulf of Paria itself, on the coast of Cumana. The deep water fishery—that is to say, the fishery in about twelve fathoms—is conducted now pretty much as it was in Columbus's time. Men accustomed from their infancy to an amphibious sort of life, and trained to be expert divers, are engaged at the work, and go down naked into the sea in order to pick up the marvelous pearl breeders which lie at the bottom. In Ceylon, the pearl fishers go out in company in their boats. Each boat carries twenty men, of whom ten are rowers and ten divers. The divers go down to a depth of from four to ten fathoms. To assist them in their descent they use a large stone of red granite,

having the smaller end bored so as to admit a rope, which is rove through it.

When about to dive, the diver seizes this rope with the toes of his right foot, and with the left foot secures a network bag for his oysters. He then takes hold of another rope with his hands and is let down from the boat to his diving ground, the stone helping to sink him. When at the bottom he casts himself loose from the stone, picks

danger the divers have to encounter, after the preliminary physical difficulties attendant upon diving and working at so great a

depth have been got over, is from ground sharks. The divers in the Persian Gulf are wont to resort to magic and to religious enchantments in the hope of guarding against these creatures; but as an additional and more effectual precaution, they are armed with a short stick, pointed at either end, which they thrust into the shark's mouth, they themselves getting away while the monster is engaged in

fretting over his uncomfortable meal.

A story is related of one diver who, having explored a rock on which he expected to find oysters, was about to return to the surface of the water, when, casting his eyes upwards, he saw a huge ground shark lying in wait for him and cutting off his retreat. Terrified at the sight, and unable to get out of range, he was beginning to give himself up for lost when a happy thought occurred to him. He took his sharpened stake, which was too small to stop the jaws of the shark, and going to a sandy nook in the rock began to stir up the mud, and to make such "a dust in the water" as to effectually obscure the enemy's vision. Having continued this till he was forced to quit for want of breath, he swam off hastily in another direction, and arrived at the surface exhausted, but in safety. At the top he was rescued by the boat in attendance, practically none the worse for his alarming experience. Numerous other hair breadth escapes could be cited.



SILVER TROWEL USED IN LAYING CORNER  
STONE OF TREMONT TEMPLE, BOSTON.

up his oysters, and when ready to return jerks the rope by which he was let down, and he is then hauled up, leaving the stone to be recovered by its own rope. The chief

FISH KNIFE.

FISH FORK.

# THE FLEMISH.

A Large Line of FANCY PIECES in this popular pattern, put up in beautiful PLUSH LINED BOXES, suitable for the HOLIDAY TRADE, NOW READY.

★ **ROGERS & BRO. A1.**

**CAUTION!**

The name of "ROGERS" is stamped on all sorts of flatware, some of it common, worthless trash. If you keep the STAR brand you sell goods that will satisfy your customers and help build up your reputation as a reliable dealer.

The STAR brand is made by

**ROGERS & BROTHER,**

...OF...

Waterbury, Conn.

16 Cortlandt St., New York.

THE OLDEST MANUFACTURERS OF "ROGERS GOODS" IN EXISTENCE.

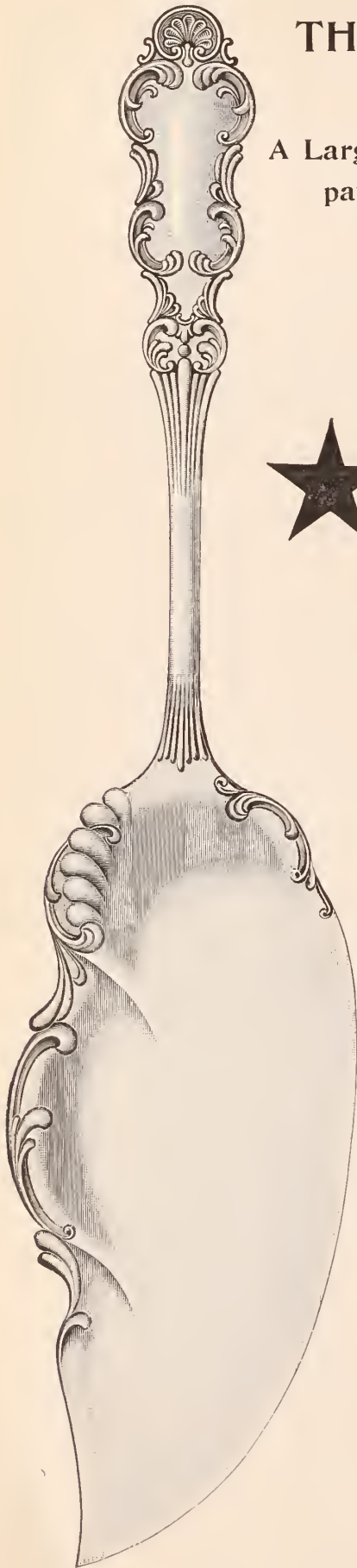

# LÉON J. GLAENZER & Co.,

80 and 82 Chambers St., New York.

—♦♦—  
**Novelties and Specialties in every Department.**  
—♦♦—

**Clocks.** Gilt, Porcelain, Enameled and Bronze, Crystal Regulators, Traveling Clocks, Hall Clocks with English Chime Movements.

**Bronzes.** Busts and Statues in real and imitation art Bronze and all the Novel Decorations.

**Lamps.** Banquet, Piano, and Princess Lamps, in Decorated Porcelain, Gilt Bronze and Enamel and other combinations.

**Fine Decorated Porcelains and Glassware.**

Sèvres Vases, Plates, Candlesticks, Inks, Flower Holders, Card Receivers, Etc. Table and Decorative Glass.

**Toilet Articles.** All kinds of Brushes, Manicure Sets, Hand Mirrors, Etc.

**Onyx Pedestals and Tables, Bric-à-Brac Cabinets.**

ALL GERMAN POTTERIES.

Dresden, Royal Bonn, Carlsbad, Teplitz, Etc., Etc.

## Now that we have touched bottom

And business generally is improving every GOOD RETAIL JEWELER should make his stock attractive and so invite customers. He can buy nothing more sure of sale than



of standard quality, at moderate cost, and of new and taking styles. If not called upon by our travelers send your orders direct to

**M. B. BRYANT & CO.,**  
10 MAIDEN LANE, NEW YORK.

**VACHERON & CONSTANTIN,**  
GENEVA, SWITZERLAND.



FINEST QUALITY OF WATCH MOVEMENTS, FITTING ALL SIZES OF AMERICAN CASES.



**EDMOND E. ROBERT,**

Agent for the United States and Canada

21 & 23 MAIDEN LANE.

NEW YORK.

## A. J. HEDGES & CO.,

MANUFACTURERS OF

Gold, Variegated and Enameled Jewelry.

**BLACK AND WHITE ENAMELED GOODS**

— A SPECIALTY. —

LACE PINS, SCARF PINS,  
BROOCHES AND PENDANTS,  
CHATELAINES AND BRACELETS,  
LINK BUTTONS AND STUDS,  
GOLD AND SILVER GARTERS

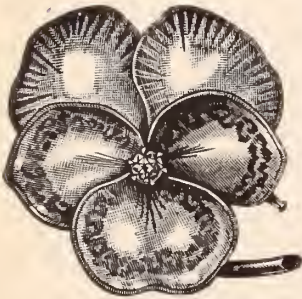

FACTORY:  
90 Mechanic St., Newark, N. J.

6 Maiden Lane, New York.

## MARINE CHRONOMETERS,

MANUFACTURED BY

**John Bliss & Co., 129 Front St., New York.**

We have on hand a number of Chronometers, by various good makers, not new, which have been in service for purposes of navigation, and are excellent instruments. They have been put in perfect repair and will give satisfactory results as to performance. We will sell these Chronometers at low prices, either for cash, or on accommodating terms to suit special cases, or will hire them at moderate rates and allow the hire to apply on purchase.

SEND FOR CIRCULAR GIVING PRICES AND TERMS.

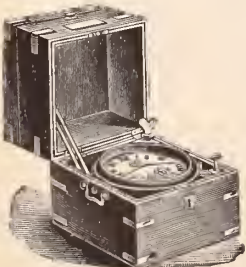

### A New Trial in the Weber Co.'s Suit Against the C. St. P. M. & O. R. R.

DES MOINES, Ia., Nov. 1.—In the suit of the Weber Co. vs. the Chicago, St. Paul, Minneapolis & Omaha Railway Co., in the O'Brien District Court, Judge Scott M. Ladd has reversed the decision of the lower court.

The plaintiff is a wholesale jewelry firm of Chicago and brought suit to recover \$1,800 for the loss of a jewelry sample trunk that had been checked over the railway from Le Mars, and there stolen. The defense was that the rule of the company was not to check jewelry sample cases, unless a permit from the general baggage agent was shown, indicating that a bond had been executed indemnifying the railway from liability for loss beyond \$50. Plaintiff had made several applications for such permits, but in answer to a special interrogatory the jury, in its determination to mulct the railway company, found that the plaintiff did not know that such permits were required. A new trial was asked, because this finding was wholly unsupported by the evidence.

The lower court overruled the motion, which the Supreme Court holds was error and reverses the decision.

### The New Silverware Works in Naubuc, Conn., Completed.

HARTFORD, Conn., Nov. 2.—Alderman William H. Watrous, of this city, who is president of the Wm. Rogers Mfg. Co., E. S. Stevens, of Wallingford, and Messrs. Turner, Goodrich and Welles, of Glastonbury, have completed the new silverware works at Naubuc, and will immediately begin business there. The tools and outfit for the manufacture of solid silverware, which were used by the Messrs. Pitkin, on Pearl St., this city, have been bought and removed to Naubuc.

A new shop has been built near the Connecticut, and a branch road from the electric line is to be laid, connecting directly with the works. The new road will extend from Station 34, the distance being half a mile. Nothing but solid silverware will be produced and a considerable number of hands will be employed. Mr. Stevens will be the superintendent of the works. The product of the shops will be used by the William Rogers Mfg. Co., of this city, who are interested in the project.

### Jeweler Frank's Political Enthusiasm Costs Him \$600.

JEANERETTE, La., Oct. 30.—A few nights ago, between 9.30 and 10 o'clock, a thief entered the jewelry store of Leo Frank and stole one tray of gold watches, one tray of sleeve buttons, a very handsome revolver and \$13 in cash. The entire loss is about \$600.

The thief entered by sawing the blinds of Mr. Frank's bedroom, which adjoins the store. The theft was committed while Mr. Frank was attending a political meeting. There is no clew to the perpetrator.



# "DELIBERATE CALCULATION"



IS ADMIRABLY PORTRAYED ON THIS FRENCH CHINA PLATE BY OUR DECORATOR,

BUT A BRIEF EXAMINATION of our CATALOGUES will convince you that he who plays a "winning game" with the Purchasing Public can do no better than select liberally from them.



ONE CENT

the price of the postal you send us, will bring back a book

TELLING WHAT \$50 WILL BUY IN

**CUT GLASS**

Then there is HOLLOW WARE of every description,

FLAT WARE, than which no better is made.

..... NOVELTIES INNUMERABLE. ....

## A WORD ABOUT CROWN PAIRPOINT FRENCH CHINA.

The JEWELER is not, generally speaking, an importer, yet he sells as nice a class of trade as exists. He can sell Fine China and Cut Glass as easily as Watches and Jewelry or Diamonds. Now we are importing genuine China blanks and decorating them here. We will import—you can buy from us. It will pay you well to talk with us about this.

SILVERWARE CATALOGUE No 10. CUT GLASS CATALOGUE No. 11.

## PAIRPOINT MFG. CO.,

BRANCH STORES: 46 Murray St., N. Y.; 224 Wabash Ave., Chicago; 220 Sutter St., San Francisco.

Factories and Studio: NEW BEDFORD, MASS.

## CROUCH & FITZGERALD.

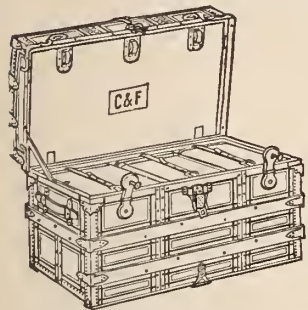

Jewelry Trunks and Cases, 161 Broadway, Bet. Cortlandt and Liberty Sts., 688 B'way, 701 6th Ave., NEW YORK.

FLAT WARE AND HOLLOW WARE STAMPED



IS THE GENUINE. Manufactured by

WM. ROGERS M'F'G CO., HARTFORD CONN.

We sell to the legitimate Jewelry and Stationery trade only.



CHOICE PAPERS

MAKERS OF

FINE STATIONERY

For Correspondence, Wedding and Business Use, handsomely boxed, specially suited to the Jewelry Trade.

18 MURRAY STREET, NEW YORK.

ALBERT BERGER & CO.  
47 MAIDEN LANE, N. Y.  
Spectacles & Optical Goods,  
GROUND LENSES A SPECIALTY.

# R. WALLACE & SONS MFG. CO.

## SILVERSMITHS,

WALLINGFORD, - - - - - CONN.



No. 20 CUTICLE KNIFE.



No. 20 CORN KNIFE.



No. 20 NAIL FILE.

Trade Mark.

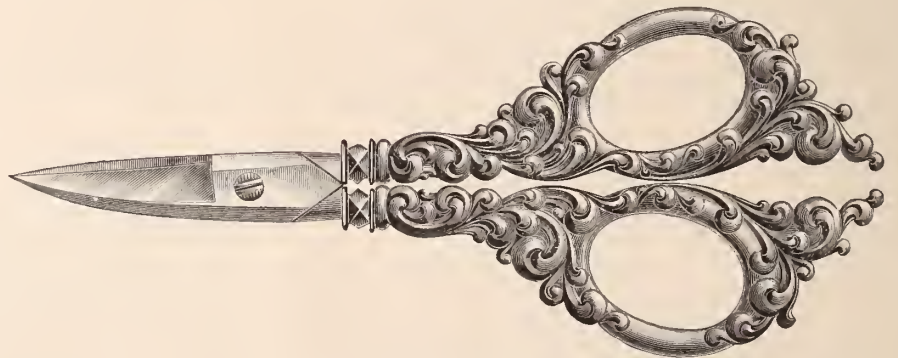

No. 20 NAIL SCISSORS.



No. 20 TWEEZERS.

NEW-YORK !  
226 FIFTH AVENUE. 5

SAN FRANCISCO,  
120 SUTTER STREET.

CHICAGO  
86 WABASH AVENUE.

### Canadian Jewelers Aroused on The Subjects of Gold and Silver Stamping.

TORONTO, Can., Nov. 2.—The agitation in the United States, looking toward the adoption of a common law in all the States compelling manufacturers to stamp the exact quality on gold and silver goods is exciting considerable attention among the trade here.

Monday evening a special meeting of the Retail Jewelers' Association of this city was held to consider the advisability of urging the Canadian government to take action on the matter. President E. M. Morphy pointed out that in case of the adoption of a National law in the United States it was altogether probable that the Canadian market would be flooded with an inferior class of American watches which could not be sold in the United States. At present, he said there are watches offered here for sale represented at 10 karats which are not more than 6 or 8 karats and matters will be much worse if such goods are practically driven out of the United States by law. It might be well to consider whether Canada should not adopt similar legislation.

The matter was fully discussed, the general opinion of the meeting being strongly in favor of compelling goods to be stamped as a guarantee of quality and a protection to the public. It was considered that as the question is one concerning all branches of the trade it was not desirable to take ac-

tion without the concurrence of the wholesale houses, and in order to secure united action it was resolved to call a general meeting of all branches of the trade for Nov. 12th.

A committee was appointed consisting of E. M. Morphy, J. Davis, Charles Spannar, J. Wanless and E. M. Trowern to wait on the wholesale and other jewelers and secure their co-operation.

### One of Mermod-Jaccard's Salesmen Accused of Heavy Theft.

ST. LOUIS, Mo., Nov. 2.—Thomas Rodgers, a salesman for the Mermod-Jaccard Jewelry Co., has been arrested on a charge of the larceny of \$2,000 worth of diamonds, consisting of two pairs of diamond earrings and one diamond stud. Rodgers refused to make any statement.

It has been the custom of the firm to go over the entire stock every morning to see that none of it has been lost. During the holidays last year this precaution was omitted. At the first stocktaking after the holidays the jewels were missed, and at different times since then pieces of jewelry have been abstracted until the value of the goods taken is said to exceed \$10,000.

President Goodman King said to a reporter: "At the request of the attorneys we have decided not to say anything for the present. Just say that Mr. Rodgers came to us three and a half years ago from Little Rock."

### Incorporation of the W. A. Graham Co.

MARLBORO, Mass., Oct. 31.—The W. A. Graham Co. have incorporated with a capital stock of \$2,500 in single shares of \$100, to "buy, sell and deal in watches, clocks, jewelry, silverware, optical goods, etc."

The promoters of the enterprise are Jas. E. Cunningham, Edwin A. Whitney and Clara E. Stiles.

### The Beautiful New Establishment of the Cowell & Hubbard Co.

CLEVELAND, O., Oct. 30.—The principal event of the Fall season in the jewelry trade here, was the change of location made last week by the Cowell & Hubbard Co. The firm left the old quarters on Superior St., which they had occupied since 1879, and where their business had grown to large proportions, and took up their position in the new ten-story Garfield building, on Euclid Ave., at the corner of Bond. The entire first floor of the new block is occupied by the Cowell & Hubbard Co., and nearly all the space is devoted to sales-rooms.

The opening was held the first of last week, and constant streams of visitors passed in and out and viewed with surprise one of the handsomest displays of jewelry west of the Alleghenies. The main sales-room, at the entrance on Euclid Ave. is 53 x 100 feet, and well lighted by large plate glass windows all along the Bond St. side. Mr. Hubbard's private office is immediately

# PRINCETON WATCHES

ARE THE LATEST TRIUMPH IN WATCHMAKING,

And are especially designed for reputable watch dealers desiring a well made, finely finished and reliable watch, which will afford a fair return for time and capital invested, and which the public do not know more about than the dealer.

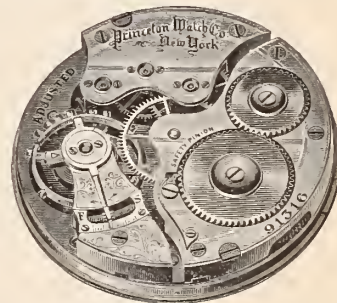
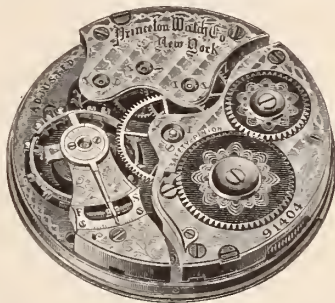
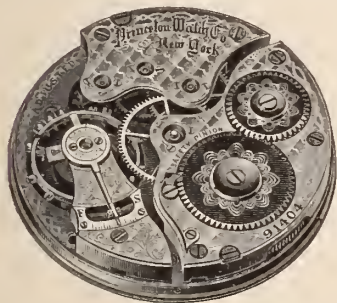

16 size, **thin model**, fitting Elgin size cases Open Face and Hunting S. W. Open Face are Pendant Set. Three Grades—Solid Nickel Movement, beautifully damaskeened and finely finished throughout; 15, 16 and 17 Ruby Jewels in Settings; Accurately Adjusted to Temperature, Isochronism and Positions; Breguet Hair Spring; Exposed Pallets; Micrometer Regulator; Safety Center Pinion; Fine Glass Enamel Dial—and at prices which are attractive.

These movements are made in Geneva, Switzerland, by the most improved American automatic machinery, insuring accuracy and precision, and finished by Swiss skilled labor, giving to them that delicacy of finish so much admired. In the selection of jewels, dials and all material, everything is of the very best.

In placing Princeton Watches on the market, it is with full confidence that their superior construction, delicacy of finish and accuracy of performance will meet with the highest appreciation by the trade.

**THEY ARE SUPERIOR TO ANY WATCH IN THE MARKET, AND AT LOWER PRICES.**

Distributed to the Retail Trade through a limited number of Jobbers as **Wholesale Agents**, under contract governing sale and protecting the Retailer. Ask your jobber for them. If he does not keep them, write us and we will give you names of jobbers who do.

Illustrated and Descriptive Price Lists sent to Regular Jewelers upon application.

In selling Princeton watches you consult the best interests of your customers and at the same time

**MAKE PROFITS FOR YOURSELF.**

**A. C. SMITH WATCH CO.,**

**177 Broadway, New York.**

CHICAGO, 1893. PHILADELPHIA, 1876. GENEVA, 1880. PARIS, 1889.

# ... EZRA KELLEY'S ... LUBRICATING OILS,

FOR WATCH, CLOCK AND CHRONOMETER MAKERS; ALSO TYPE WRITERS, MECHANICS AND SEWING MACHINE OILS  
**HAVE BEEN INVARIABLY VICTORIOUS.**

The discovery of a Lubricator for **Fine Machinery**, such as Watches, Clocks and Chronometers, that is free from gum and glutinous matter, has taxed the ingenuity of hundreds of men whose efforts have proved a failure; but we are happy to say (being largely interested) that such an article has been supplied by

**MR. EZRA KELLEY, OF NEW BEDFORD, MASS.,**



Who, after sixty years of study of the subject, perfected a lubricator that recommends itself to all who have used the **GENUINE**, there having been numerous counterfeits in the market, as witness also the *first class awards and diplomas* by the judges at the *Exhibition in Philadelphia in 1876, Geneva in 1880, in Paris in 1889*, receiving the only medal awarded to an American exhibitor of oils, and at the *World's Columbian Exposition, Chicago, last year.*

It is for the interest of every Watch, Clock and Chronometer Maker and Repairer to use in his work the **BEST**



oil obtainable, regardless of cost. EZRA KELLEY'S claims to be the **foremost manufacturer of the Best, Purest and Finest Oils**, giving the best results, is not based upon his own assertion, but is founded upon the fact that wherever his oils have been exhibited in competition with other makes subject to an examination by experts, they have received the highest award of merit. We have no hesitation in saying that his oils are the **best** manufactured, always uniform in quality and capable of standing all tests applied to lubricating oils.



P. S.—There are two grades of Clock Oil, the "Superior" and the "American." The Superior is adapted for lighter bearings, as found in French, German and Swiss Clocks. The American for American Clocks, Gun and Locksmiths' use, it having more body and being adapted for heavier bearings.

The above oils can be procured at all first-class wholesale Watch and Clock Establishments in the United States, as well as at wholesale of his only Agents,

**HENRY GINNEL & CO.,**  
21 MAIDEN LANE, NEW YORK.

**GRIMSHAW & BAXTER,**  
35 GOSWELL ST., LONDON, ENGLAND.

## CARBORUNDUM.

### Net Retail Price List of Carborundum Wheels.

ACESOF'S PATENT, February 28th, 1893.

Diam. in Inches	THICKNESS IN INCHES.																Rev. per Minute.	
	1/4	3/8	1/2	5/8	3/4	7/8	1	1 1/4	1 1/2	1 3/4	2	2 1/4	2 1/2	2 3/4	3	3 1/2		4
1	\$.15	\$.18	\$.20	\$.23	\$.25	\$.28	\$.30	\$.35	\$.40	\$.45	\$.50	\$.55	\$.61	\$.65	\$.70	\$.80	\$.90	18,000
1 1/2	.18	.22	.25	.28	.31	.33	.35	.40	.45	.50	.56	.62	.67	.73	.78	.90	1.00	14,000
2	.21	.25	.30	.34	.37	.40	.42	.46	.52	.58	.65	.70	.77	.85	.91	1.00	1.20	11,000
2 1/2	.25	.30	.37	.42	.46	.48	.50	.55	.60	.67	.75	.80	.91	.98	1.05	1.20	1.40	8,800
3	.30	.38	.45	.50	.55	.58	.60	.65	.70	.78	.85	.95	1.05	1.15	1.25	1.45	1.65	7,400
4	.35	.45	.55	.65	.75	.81	.85	.90	.95	1.10	1.30	1.50	1.65	1.80	2.00	2.15	2.35	5,500
5	.45	.60	.75	1.05	1.15	1.25	1.35	1.65	1.90	2.20	2.45	2.75	3.15	3.55	3.95	4.15	4.65	4,400
6	1.10	1.20	1.25	1.45	1.60	1.80	1.95	2.35	2.75	3.15	3.55	3.95	4.35	4.75	5.15	5.95	6.75	3,700
7	1.35	1.55	1.70	1.90	2.10	2.35	2.60	3.15	3.70	4.25	4.80	5.35	5.75	6.45	7.00	8.10	9.20	3,160
8	1.65	1.90	2.15	2.45	2.75	3.05	3.35	4.05	4.80	5.50	6.25	6.95	7.65	8.35	9.10	10.50	12.00	2,750
9	2.00	2.40	2.65	3.10	3.40	3.80	4.15	5.10	5.45	6.90	7.80	8.75	9.65	10.55	11.45	13.25	15.10	2,450
10	2.45	2.80	3.25	3.70	4.15	4.65	5.10	6.25	7.40	8.50	9.60	10.70	11.85	12.90	14.05	16.30	18.55	2,200
12	3.60	4.00	4.40	5.10	5.80	6.50	7.20	8.80	10.40	12.00	14.60	15.20	16.80	18.40	20.00	24.55	26.40	1,830

CARBORUNDUM was awarded both a Medal and a Diploma at the World's Columbian Exposition in recognition of its merits as an Abrasive, the hardness being greater than any other abrasive material.

The wheels are made with a vitrified bond, and pressed under hydraulic pressure. Those over three inches in diameter are turned up after firing. The same numbers are used to designate the degrees of fineness, as are used with Emery, and the wheels are made in seven degrees of hardness, marked SSS, SS, S, M, H, HH, HHH, from extremely soft to extremely hard.

In ordering, state diameter, thickness, hole, number and hardness.

Monongahela, Pa., U. S. A.

THE CARBORUNDUM COMPANY.

Hones, Slabs, Files.

Cut = This = Out.

JOBBER'S IN

IMPORTERS OF  
**DIAMONDS.**

Watches, Jewelry, Chains,  
NOVELTIES, ETC.

**AIKIN-LAMBERT  
JEWELRY CO.,**

Latest Designs. Lowest Prices.

19 Maiden Lane, New York.

CHICAGO BRANCH: 103 STATE ST.



to the right of the entrance. The show cases, center cases, counters and wall cases are of walnut and rosewood set with plate glass. All the cases are lighted from the interior by small electric lights, adding materially to the brilliancy and attractiveness of the display. In the corner of Euclid and Bond, between windows on both sides, is the display of diamonds.

At the rear of the main room is the optical department, which is under the supervision of the specialists, Drs. Clark and Jordan. A slight elevation leads through a 30 foot entrance to the china, glass and art department, (a new department for the firm, by the way) which is filled with exquisite china, cut glass, lamps and bric-à-brac. Frank Martin, for years with I. T. Bowman & Sons, will have charge of this department. In the rear and extending through to Vincent St., are the engraving and work rooms, which are equipped with every appliance known to the trade to facilitate and execute fine work.

President Hubbard has as his assistants: J. H. Danforth, secretary and treasurer; J. H. Vansant, retail manager; F. L. Haldy, Frank Patton, Fred. Van Buskirk, Frank Moore, W. D. McVitty, and J. H. McMillin.

**The Connecticut Retail Jewelers' Association Begin Their Crusade.**

HARTFORD, CONN., Oct. 31.—William J. Pierce, who has for the past year and a half conducted a watch club in this city, for the Standard Jewelry Co., of Meriden, was arrested last night on a warrant which was issued on complaint of the newly organized Retail Jewelers' and Opticians' Association of Connecticut.

Pierce is charged in the writ with conducting a watch scheme contrary to the statutes of the State, and with selling lottery tickets. Mr. Pierce's office is on Pearl St., and he has done quite an extensive business in the disposal of watches and jewelry through the club.

The clubs contain 100 members each. Each member agrees to purchase a watch or piece of jewelry, valued at \$35, by paying \$1 a week. Each ticket of membership is numbered. Every week, by means of a drawing, the holder of the ticket corresponding with the number drawn, is released from further payment. Consequently one man gets out the first week and gets his watch for \$1; the next week another man gets out for \$2, with a watch, and so on. Thirty-five drawings are held and at the end of that time, the remaining 65 members are given their watches outright, they having paid \$35 each.

The drawings are held in a real estate office. At the time of the arrest there were a few men behind the counter and perhaps 25 in the room.

Pierce says he is only a collector for the company and has no connection with the drawings. He was locked up after his arrest, but obtained bonds two hours later, one, Thomas R. Shannon going his surety for \$350.

# THE BOWDEN SEAMLESS RING

IS MADE ONLY BY

## J. B. BOWDEN & Co.,

Makers of Finger Rings of every Description.

REMOVED FROM BROADWAY AND JOHN STREET,

### TO 3 MAIDEN LANE,

NEW YORK.

## HAGAN, WHITE & CO.,

MANUFACTURERS OF

### GOLD AND SILVER MOUNTED CANES, UMBRELLAS & NOVELTIES.

RICH AMERICAN CUT GLASS, SILVER MOUNTED.

248 WEST 23D STREET, NEW YORK.

Sold by all wholesale dealers at manufacturer's price.

A. N. CLARK & SON  
PLAINVILLE  
CONN.

Manufacturer of the Celebrated  
**LOOP WATCH KEY.**

The Best for the Price in the World.  
CROSBY'S JEWELING TOOLS IMPROVED.

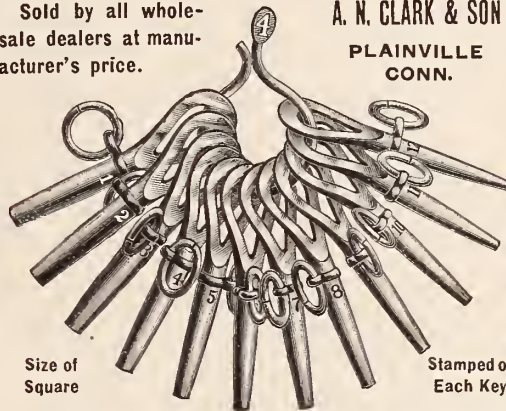

Size of Square

Stamped on Each Key.



Will quote royalty or price for the manufacturing of articles of real worth.



## REORGANIZATION SALE OF Opera and Field Glasses.

We have for immediate sale the largest and best selected stock of Opera and Field Glasses in this country, and offer them at fully 25 per cent. below cost. A few specimen items:

- 75 Non-Achromatic Field Glasses**, 24 lines objective, in case,  
REGULAR PRICE, \$3.25, REDUCED TO.....**\$2.00**
- 50 Colmont Field Glasses**, 26 lines objective, in case,  
REGULAR PRICE, \$6.00, REDUCED TO.....**\$4.90**
- 85 Non-Achromatic Opera Glasses**, 15 lines objective, in case,  
REGULAR PRICE, \$9.00 per doz., REDUCED TO..... **\$5.25** per dozen
- 50 Achromatic Opera Glasses**, leather covered and japanned, 15 lines objective, in case,  
REGULAR PRICE, \$1.75 each, REDUCED TO.....**\$1.35** each.
- 50 Achromatic Opera Glasses**, leather covered and japanned, finer quality, 12 lines objective, in pocket book case, REGULAR PRICE, \$2.25 each, REDUCED TO.....**\$1.55** each.
- 40 Achromatic Opera Glasses**, pearl covered, 15 lines objective, in case,  
REGULAR PRICE, \$3.75 each, REDUCED TO.....**\$2.90** each.
- 36 Achromatic Opera Glasses**, pearl covered, 17 lines objective in case,  
REGULAR PRICE, \$4.50 each, REDUCED TO.....**\$3.70** each

SEND FOR SAMPLES.

### QUEEN & CO., Opticians,

1010 Chestnut St., Philadelphia.

J. G. GRAY, Assignee.

## ADVERTISING HINTS FOR RETAIL JEWELERS.

BY CHARLES AUSTIN BATES.

The Editor of THE JEWELERS' CIRCULAR has asked me to contribute a series of articles on retail jewelry advertising.

It is my desire to make these articles as useful as possible and to that end, an invitation is extended to retailers to send to me any of their advertisements which they would like to have criticised. It may be that there are some questions which they will care to ask and that I can answer.

Each week I will give several examples of advertising, which will illustrate my ideas on the subject. I do not present these advertisements with the claim that they are perfect, but only with the hope that they will contain some useful suggestion, and that some dealer at least will find that by making slight changes in them, as local conditions require, they will be able to make use of them, and so relieve themselves of one detail of their business.

### PART V.

**T**HERE is no use advertising in a half-hearted way. Somebody, I don't remember just who, said: "He who asks timidly, courts denial." This is as true in advertising as in anything else. One of the best things an advertisement can do is to convince readers that the advertiser is in dead earnest about his business, that he means what he says, and expects to be believed.

A merchant ought to believe in his own goods. He ought to be in love with his business. If he states his belief clearly, forcibly, earnestly in his advertisements, it will kindle belief in others, and he will gain trade. One of the best advertisements I ever saw was that of an electrotyper. It was quite a good sized advertisement, and the biggest line in it was this: "I want your work." It was a direct appeal to every one who saw the advertisement.

There was no mistaking what that advertisement was for. The man was after business, and he didn't care who knew it. He went on to say why he ought to have the work he wanted. Of course, the jewelry business is a little bit different, but all businesses are more or less alike, and all advertising has one object. It is meant to sell goods. There is no use trying to disguise that, it is no use trying to make people believe that you are in business for any other reason than a desire to make money.

### FINE WATCH REPAIRING.

If you have a good watch you think lots of it.

If it stops you want it repaired by a competent man.

Take it to

**B. ROMBACH,**

East Side of Square.

He will repair it as good as  
[new at low prices.

I suppose there are a great many worse ads published than this one, which I clipped from a Paris, Tex., paper. The display isn't bad, and really the strongest criticism I have to make of it is that there is no snap about it. It was written to fill space, and sounds as if Mr. Rombach didn't really expect to get any business from it, but merely put it in because he had the space and had to put something in it.

\*\*

Just at this season probably the hard drive for business ought to be modified somewhat, but the advertising need be none the less earnest. The advertising for the next six weeks ought to be made attractively interesting, and it can be made so if the jeweler will take a little trouble. Let him forget that he is writing an advertisement, and remember that in reality he is only talking to one person at a time, that only one person can read his ad. at one time. Let him talk to that person just as if he was at his elbow.

There are a thousand things in a jewelry store that will furnish the theme for a readable, interesting, attractive advertisement. Take one article or one class of articles at a time and describe them as accurately as possible. Tell just exactly what you see about them that makes them good and desirable. Certainly when you bought them you had some idea that for a particular reason that particular thing would sell. That's the idea to put into the advertisement. It doesn't make much difference what the thing itself amounts to. Maybe you couldn't sell enough of them in a year to pay for the advertisement for a week, but put the whole strength of the "ad." on it just the same. If you have a heavy gold bracelet with big links and padlock, that would make a good present for a young man to give to his best girl, tell him about it, and make the description as accurate and attractive as you can. Next day take something else. The fashion columns of the papers often give a good cue for advertising. Quite frequently some little item appears in the miscellany matter in the local paper that could be turned to good advantage by making proper use of it. Fads are continually springing up, and should be made use of.

At this season of the year, more than any other, the ads. ought to be suggestive and

furnish ideas to those who haven't any—and there are a great many people of that sort. I think one of the best things that can be done is to change the advertisement as often as possible. Talk about only one thing at a time, and in every advertisement, give a good strong invitation to people to come in and look around. Tell them that there are a great many pretty things in your Fall stock, and that you are proud of them and glad to show them, and glad to have people see them, whether they buy or not. Let them understand that the goods are pretty enough and good enough to sell to *somebody* between now and the holidays. That you feel perfectly sure that they will be sold, so that it makes no difference whether the particular reader you are then addressing buys or not.

\*\*

The following suggestion for a jeweler's ad. appeared in *Printers' Ink*, recently:



**CAPTAIN  
CUTTLE'S  
WATCH**

Had to be pu-hed back a "half hour in the morning and a quarter of an hour in the afternoon," to make it a "watch seldom ekalled but never excelled."

Our new stock of watches have the Waltham movement, and consequently need no such operation.

**Diamonds and Silverware, too.**

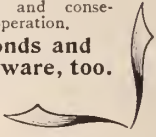

Many other interesting incidents in fiction are adaptable for effective advertising.

\*\*

### Suggestions for Pictorial Retail Jewelers' Ads.

The page of suggestions for pictorial retail jewelers' ads. published in THE CIRCULAR, Oct. 3, elicited considerable favorable comment from the trade, many dealers requesting electrotypes of the designs. This success has induced THE CIRCULAR to make such a page of ideas one of the many features of these columns. The essential parts of these advertising ideas are the illustrations. The reading portions, even the catch lines, are susceptible to change, depending upon local conditions, and the circumstances surrounding the jeweler's business. Some of the suggestions, however, may be worthy of reproduction in their entirety. Electrotypes of the pictures will be furnished at the rate of 50 cents each, which approximately covers the cost of electrotyping, mailing, etc.

It is said that window panes of porous glass are being made in Paris. The minute holes in the glass are too fine to permit of a draught and yet large enough to cause a pleasant and healthy ventilation in a room.

SUGGESTIONS FOR FALL PICTORIAL ADVERTISING.

SEE PAGE OPPOSITE.



LOVE AND BEAUTY

Are always allied, for love itself is beautiful, while the beautiful always inspires love. Love finds higher expression in jewelry than in any of the other art handiwork; the jeweler is essentially love's artificer.

The love of the beautiful has never been so universal as it is to-day; and the designers and manipulators of jewelry have never had their power of conception and their dexterity more taxed. The result is that the jewelry of to-day is in the highest sense artistic. It has assumed forms that are popular in all classes—Belt Buckles, Czarinas, etc.

Call and see

HART & BOOTY,  
213 Main Street.



A TON OF DIAMONDS

Is worth \$35,000,000, more or less.

We do not expect that you will favor us with such an order, but our fine line of

DIAMOND JEWELRY,

purchased to fill the requirements of the Fall and Holiday seasons, offers opportunities for the selection of the latest styles—to accommodate all tastes and purses, from the most simple and modest to the most elaborate and costly.

STERLING & GOODE,

125 Some Street.

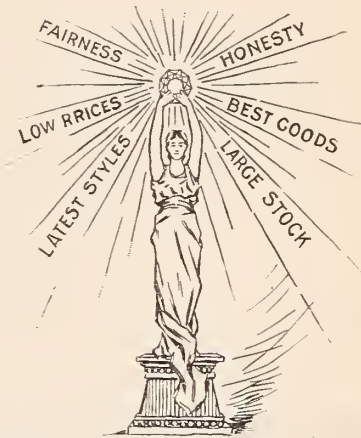

OUR GUIDING STAR,

Reflecting the mottoes as above, has, we feel assured, brought us into the harbor of confidence the public.

It is a temerarious undertaking to accept the diamond as the emblem of one's career; for this gem is the quintessence of purity and brilliancy.

The DIAMOND JEWELRY, in all its fashionable forms, just purchased for the Holiday season by us, shows these qualities to the highest extent—Clusters, Solitaires, Fancy Stone Combinations.

FIN DE SIECLE & CO.,

516 Any Street.



AFTER A TIME

We come to the conclusion that a clock is a nice present to make to your wife, or to a friend who is about to be married. No article combines beauty and utility more effectively.

(List of clocks, with prices.)

PORCELENE clocks, simulating porcelain perfectly.

MARBLOID clocks, simulating marble perfectly.

TIMELIE & CO.,  
130 Spring Street.

IT'S A LONG TIME

since the demand for fine jewelry has been so strong. In anticipation of a brisk holiday business, we have purchased a large and fine stock of the latest novelties in Jewelry; also of Silverware, Clocks, Bric-à-Brac.

The earlier orders are placed, the better may the selection be, though we are constantly adding to our stock.

J. J. JONES & CO.,  
16 Steenth St.



LOW PRICES  
RELIABLE GOODS  
LATEST STYLES  
BEST QUALITY

FRAMED WITH JEWELS.

The business principles cited above are worthy of being framed with jewels. They are ours. Have you seen our window display of jewels? If you have any sense of the artistic you are bound to be interested in it; if you contemplate giving your wife, daughter, son, mother, father, sister, brother, sweetheart, or other person dear to you, some token of regard or remembrance of the season, you will see in this display something that will fill the bill.

PUSHE & GOE,  
90 Onety-oneth St.

### Three Men Who Burglarized S. R. Bushby's Store Captured.

READING, Pa., Oct. 31.—Recently S. R. Bushby's store here was robbed of \$900 worth of jewelry. Officers have been working on the case ever since, and three men are now in custody for committing the robbery. Two of them, Frank Kessler and A. D. Haveracker, are already in jail here. The third, Henry O. Goetz, is locked up in the guardhouse of the Brooklyn navy yard, pending the arrival of requisition papers. Haveracker has made a clean breast of the affair. Goetz is 19 years of age, and the officers located him in the navy yard at Brooklyn. He had deserted from the marine service a year ago, but a few weeks ago returned to his post. Haveracker says

that most of the goods were sold in Philadelphia and Camden.

### Wilson Bros.' Salesmen Enjoy Their Annual Banquet.

BOSTON, Mass., Nov. 1.—The salesmen in the employ of Wilson Bros., this city, have an association which sits down annually to a feast of epicurean delights. Last evening their sixth annual banquet was enjoyed at Young's Hotel, and an election of officers followed the discussion of the menu with the following result: President, S. J. Byrne; vice-president, F. C. Babbitt; treasurer, G. W. Hopkins; secretary, G. T. Wilson.

Among the participants were: President S. J. Byrne, vice-president F. C. Babbitt,

who presided during the earlier portion of the evening, the president being unavoidably detained, George T. Wilson, G. W. Hopkins, who was chairman of the committee in charge, R. M. Cook, J. S. Martin, G. W. Foskett, George Murphy, C. S. Wilson, Henry S. Arnold, Arthur Muzzey, Charles De Voe, Thomas Kennedy, Albert Wood, George Weldon, M. Hennebury, A. L. Lawrence, W. F. Dunnell, T. A. Collins, M. Nicholson, and as guests W. O. Thiery J. Woodman, Louis J. Kleh, C. E. Young and Dean Southworth.

Letters of regret from C. S. Sweetland and I. W. Stelle were read. The after dinner exercises comprised brief addresses and vocal and instrumental solos by several of the members.



Enamel Portraits done by Photography and Hand Painted on Porcelain or Enamel at one-half the prices you used to pay.

Pictures from Celebrated Galleries. Club Devices Applied in Enamel. Repairing.

Half Pearl, Diamond, Gold and Sterling Silver Scarf Pins, Brooches and Novelties.

Clarence W. Sedgwick  
11 EAST 20th ST., NEW YORK.

### Kansas City.

Louis Meyer, president of the Meyer Jewelry Co., 1018 Main St., applied in the Probate Court a few days ago for letters of administration on the estate of his wife, Bertha Meyer, who died Dec. 30 last. Judge Guinotte appointed Mr. Meyer administrator.

C. B. Wilson and Thomas Morton have been arrested on a charge of stealing four watches from S. Lavene's showcase at 311 Main St. It is charged that Wilson occupied the jeweler's attention while Morton slipped behind the showcase and abstracted the watches. Three of the watches had been pawned when the men were arrested.

## H. M. SMITH & CO., MANUFACTURERS,

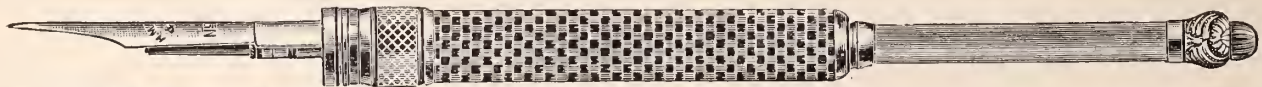

83 NASSAU STREET, - - NEW YORK CITY.  
New Catalogue Just Issued.

# OPPENHEIMER BROS. & VEITH,

OFFER TO THE TRADE

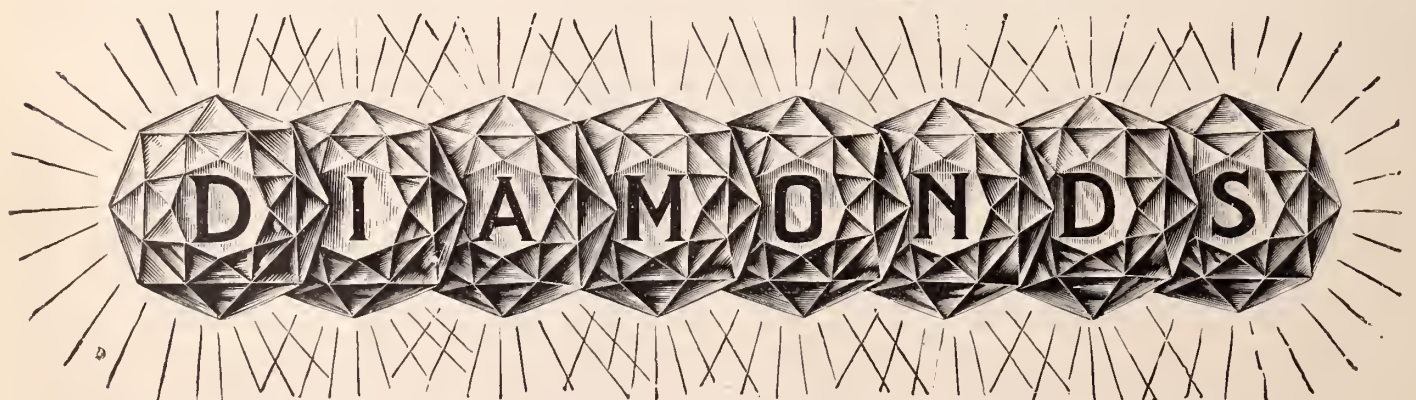

Cut by them according to scientific principles, at prices far below imported goods of the same quality.

NEW YORK, 35 MAIDEN LANE,

Amsterdam, 2 Tulpstraat,

London, Eng., 27 Holborn Viaduct.

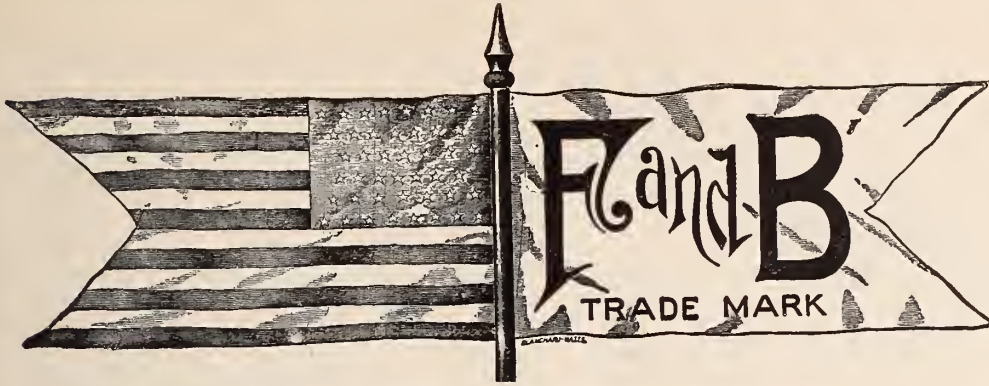

# FOSTER & BAILEY,

100 RICHMOND ST.,

PROVIDENCE, R. I.



ONE QUARTER SIZE.

Be sure and see the Manicure Goods that we have just put out. This cut shows a set in a nice box, lined with Chamois, and is a quarter size. Beautiful Goods. The steel parts are made by the famous Henckles, of Germany, and are considered the best in the world. We make the goods in Sterling Silver and also in Tenth Gold, and at such a low price! The goods are boxed just right, so that a traveler can carry them in a trunk, and take up but little room. Sets without the large tray and buffer box and others with less pieces at low prices.

No. 1, 2, 3 is Sterling Silver. No. 4, 5, 6 Tenth Gold. Every piece is numbered and can be ordered separate, and at prices that will sell the goods. We make a specialty of Sterling Silver Novelties, comprising

Match Boxes, Manicure Articles, Shoe Buttoners, Embroidery Scissors, Garters, Paper Cutters, Ladies' Seals, Etc. All  $\frac{925}{1000}$  Fine.

#### Rolled Plate Watch Chains

Our Chains can be safely sold to the best trade, and guaranteed as superior quality. No chance of poor quality where chains are stamped F. & B.

#### Gold Vest and Dickens Chain

Soldered with 10 K. Gold Solder. Will assay 1-10 Gold.

#### Chain Mountings

We are headquarters, and make everything in this line.

#### "Mount Hope" Buttons

Superior to any button in the world. Easy to put in and take out of the cuff.

#### Solid Gold Lockets

With Diamonds and without. This is a beautiful line and solid throughout.

#### Link Buttons

We are making some very pretty styles in Roman, chased, engraved and plain, with and without stones, Sterling Silver and Rolled Plate.

#### Locket and Charms

We make them in endless variety.

#### Sterling Silver Goods

Match Boxes, Manicure Articles, Shoe Buttoners, Embroidery Scissors, Garters, Paper Cutters, Ladies' Seals, and various novelties, all  $\frac{925}{1000}$  fine.

#### Bracelets

Curb Bracelets in all sizes, with padlocks and snaps, chased and plain polished, Roman, rolled silver plate and sterling silver. We make padlocks with keys and also with a push snap, which are very popular.

#### Neck Chains and Lorgnette Chains

#### Pins

Lace and Cuff Pins, with gold fronts, engraved, also trimmed pins, Scarf Pins. Baby Pins with Chain. Also Baby Buttons with Chain. Word Pins with Scabbard and Chain. Belt Pins.

#### Glove Buttoners

#### Crosses

Four sizes of gold filled in plain, engraved, and set with stones.

#### Earrings

A nice line in engraved and trimmed. Eye Glass Chains in Gold and Plate. We received four awards and a medal at World's Fair.



# Perfect Construction

AND

## SUPERIOR FINISH

MAKE OUR PRODUCTIONS OF  
HIGHEST GRADE.

JEWELERS and  
FANCY GOODS DEALERS

will find in our new line of

### Art Metal Goods

many articles specially adapted  
to their trade.



### The Finest Line of Banquet Lamps

EVER PRODUCED.

Fitted with the Celebrated "B. & H." Burner.

New and Attractive Designs and Finishes. Sure to be Ready Sellers.

We will send you our Little Book, giving more information, if you desire, and will be glad to have you visit our Salesrooms and see the Goods.

## BRADLEY & HUBBARD MFG. CO.,

NEW YORK, PHILADELPHIA, BOSTON, CHICAGO,  
26 PARK PLACE 710 BETZ BLD'G. 160 CONGRESS ST. 204 MASONIC TEMPLE  
TO 21 BARCLAY ST. FACTORIES AND OFFICES, MERIDEN, CONN.

## MATHEY BROS., MATHEZ & CO.

21 & 23 MAIDEN LANE, N. Y.  
BRASSUS, SWITZERLAND.

MANUFACTURERS OF  
THE SMALLEST,  
THE THINNEST,  
THE NEATEST AND  
THE BEST

### SPLITS.

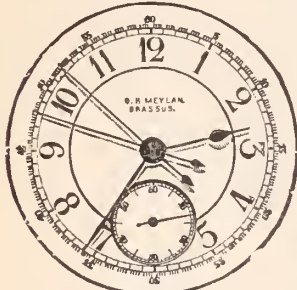

10 Size.



10 Size.

SOLE AGENTS FOR

## JAIQUES • LECOULTRE • RAZORS.

**J.B. & M. KNOWLES & CO.**  
MAKERS OF  
**STERLING SILVER WARE**  
FACTORY PROVIDENCE R.I. SALESROOM 860 BROADWAY N.Y.

### Organization of the Retail Jewelers' Association of Worcester County.

WORCESTER, Mass., Nov. 1.—The adjourned meeting of the retail jewelers of Worcester county, was held at the Bay State House Tuesday afternoon, Oct. 30. W. H. Robinson was made chairman and A. C. Bruce, secretary, *pro tem*. Newton Dexter spoke at length on the aims and objects of the organization, which is to look to the better protection of its members against trade abuses. He suggested the several reforms as enumerated in the reports of meetings in New England.

R. C. Eldridge, of Milford, spoke in favor of organization. He was convinced that one man was powerless to maintain his own rights. The jewelers are looked upon by a large part of the public as blacklegs and thieves, and they should organize to vindicate themselves.

After some time spent in general discussion, J. P. Weixler moved that those present organize the Retail Jewelers' Association of Worcester County. The motion was carried unanimously.

Mr. Dexter read a preamble and constitution, which were accepted temporarily. A committee was appointed to fill the blanks in the constitution, consisting of R. C. Eldridge, of Milford, J. P. Weixler and C. W. Wilcox.

A committee, consisting of Mr. Newcomb, of Fitchburg, Mr. King, of Southbridge and Mr. McFarland, of this city, brought in the following list of officers, who were unanimously elected: President, R. C. Eldridge, of Milford; vice-president, Nelson H. Davis, Worcester; treasurer, Charles E. Webber, Fitchburg; secretary, A. C. Bruce, Worcester. The election of a board of directors was postponed until the next meeting.

Mr. Hewey, of Winchendon, Mr. Wilcox, of Milford and J. P. Weixler were appointed to draw up by-laws. It was voted that circulars be sent to the craft in Worcester county to be present at the next meeting, which will be held in about two weeks.

The following jewelers were present: Bruce & Chapin, F. A. Knowlton & Co., N. H. Davis, Charles M. McFarland, Stockwell & Pratt, England & Leavitt, Herman Lucke, J. P. Weixler, Worcester; C. W. Wilcox, Milford; C. E. Monroe, Southbridge; G. W. Sayer, Spencer; J. W. MacVine, E. A. Chandler, West Gardner; F. W. Barnes, Uxbridge; G. W. Tewksbury, Westboro; C. W. Bergmann, Webster; G. S. Strout, Clinton; G. A. Bailey, West Brookfield; H. A. Hewey, Winchendon; Charles E. Webber, Fitchburg; R. C. Eldridge, Milford; Mr. Dewey, Winchendon; Mr. King, Southbridge.

Arthur Maltby, who has been superintendent for Maltby, Stevens & Curtiss Co., Wallingford, Conn., will take a responsible place at the Stevens' shop in Naubuc, manufacturing novelties. F. M. Chambers will succeed him in Wallingford.

LATEST STYLES  
 . . . IN . . .  
**FINE JEWELRY.**

GOLD BUCKLES,  
 HAIR PINS,  
 BACK COMBS,  
 SIDE COMBS,  
 NECK ORNAMENTS, Etc.

John A. Riley & Sloan Co.,  
 Broadway and 17th Street,  
 NEW YORK.

New Firm.

Latest Methods.

Best Results.

SEND US A TRIAL SHIPMENT

*And Convince Yourself.*

RESULTS TALK LOUDEST.

**GUILD & GARDINER,**  
 Assayers,  
 REFINERS AND SWEEP SMELTERS,  
 189 Eddy St., Providence, R. I.

**2 MEDALS AWARDED**



Wm. K. POTTER,  
 TORTOISE SHELL WORKS PROV. R. I.  
 AT  
 WORLD'S  
 FAIR,  
 1893.

Providence Shell Works, Providence, R. I.  
 Correspondence Invited

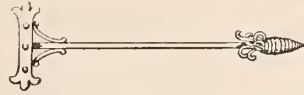

**MUSICAL BOXES**

**E. L. CUENDET,** 21 John Street, New York City.  
FACTORY AT AUBERSON, SWITZERLAND. ESTABLISHED 1828.

Send for our New Illustrated Catalogue for 1894, containing Full Particulars and Price Lists.

**\$3.00 FORMERLY \$6.00**

Ivory and  
 Enamel  
 Miniatures  
 Best  
 Workmanship.



Original  
 Inventor and  
 Patentee of

**Miniatures**

—OR—  
**Gold and  
 Silver.**

PATENTED  
 November 12, 1889

**LEON FAVRE,** 107 EAST 26TH STREET,  
 NEW YORK.

**H. M. RICH & CO.,**  
 Jewelry · Auctioneers,  
 21 School Street,  
 BOSTON, MASS.



SPECIAL SALESMAN OF

**WATCHES, DIAMONDS,**  
 Bric-a-Brac  
 and Art Goods  
 FOR  
**Established Jewelers.**

WRITE FOR PARTICULARS.

Communications Strictly Con-  
 fidential.

References given in all parts of the  
 United States from Retail-  
 ers and Jobbers.

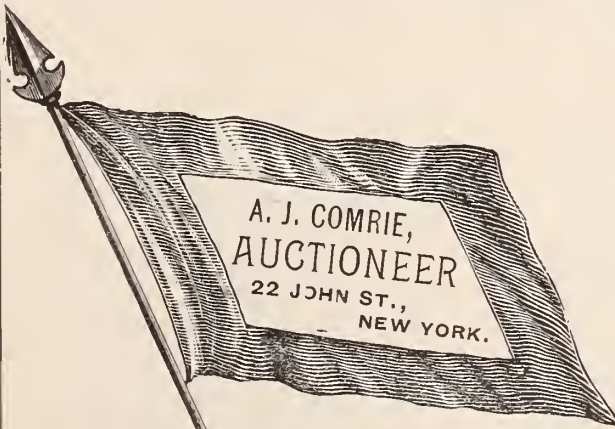

**Fountain Pen 14 Kt. solid Gold Nib**



**\$7.50** Net Cash  
 DOZ. with Order.

Elegant Plush Lined Box FREE. Every Pen Warranted. Send for Catalogue.

**DIAMOND POINT PEN COMPANY, 7 Astor House (Broadway), New York.**





**Jewelers of Hampden County, Mass., Organize.**

SPRINGFIELD, Mass., Nov. 5.—The jewelers of Hampden County met last week in the Board of Trade rooms and formed a permanent organization, to be known as the Retail Jewelers' Association of Hampden County. The following officers were elected: President, F. E. Ladd; vice-president, M. F. Robinson; secretary, F. A. Hubbard; treasurer, George Woods. The board of directors will include jewelers from nearly all of the cities and towns of the

county, and the members will be elected at a meeting to be held in about a week. Several committees will also be appointed at that time. A committee consisting of Jewelers Rand, of Holyoke, and Hubbard and Eldridge, of this city, was appointed to draw up a constitution and by-laws, which will be presented at the next meeting.

At the meeting held for organization, Newton Dexter was present and spoke at some length upon the value of such an organization as was being formed.

**The Death of Louis Lindemann.**

COLUMBUS, O., Nov. 3.—Louis Lindemann, who recently assumed control of the Columbus watch factory died Tuesday and was buried Thursday.

Mr. Lindemann by enterprise and thrift amassed a large fortune. Aside from being director of the New Columbus Watch Co., he was a stockholder and director of the Columbus Machine Co., Electric Light Co., and the first National Bank. The failure of the Columbus Watch Co., on Jan. 1st, was a severe blow to Mr. Lindemann and it is

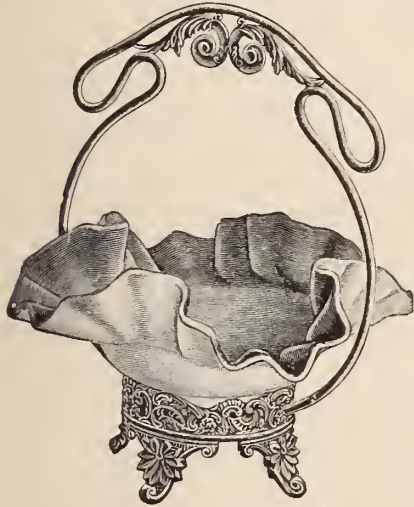

No. 961. JELLY OR OLIVE DISH.



No. 1920. BROWNIE CHILD'S PLATE.  
Illustration is  $\frac{1}{3}$  size.



No. 1999 $\frac{1}{2}$ . CUP.

IT IS WELL WORTH REPEATING that you should look very carefully into the matter of buying your **PLATED WARE FOR THE HOLIDAYS.**

We have said that our wares were the best in every way—best styles—best finish—best for the money—best sellers.

You'll never know the truth of this until you try them, just as many other jewelers have already done. They are now convinced—you will all be, in time.

**HOMAN & CO., SILVER PLATED WARE,**

OFFICE AND FACTORY:  
10 to 18 East 7th St., CINCINNATI.

CHICAGO SALESROOM:  
155 State Street.

ARE YOU PUSHING THE SALE OF -----

**TRENTON MOVEMENTS?**

IF NOT, WHY NOT?

For intrinsic value and great merits, combined with **LOWNESS OF PRICE**, they far surpass any movements ever placed on the market.

A sample line will thoroughly convince you that it will be to your advantage to handle them extensively.



6 SIZE, 7 JEWELS.



16 SIZE, 16 JEWELS.

INSIST UPON HAVING THEM.

**TRENTON WATCH CO.,**

TRENTON, N. J.

# “Pickanniny Pair.”



PRICE \$5.00 A PAIR.

ART GOODS  
FOR JEWELERS.

LEVY, DREYFUS  
& CO.,

9 & 11 Maiden Lane, N. Y.



READ WHAT THE JEWELERS' CIRCULAR SAYS:

“The ‘Pickanniny Pair,’ here illustrated, are excellent representatives of the smaller pieces in the line of decorated Majolica figures carried by Levy, Dreyfus & Co., 11 Maiden Lane, New York. The pieces, which stand about 8 inches high, are in natural colors. The workmanship is excellent and the details, as the facial expression, pose and other characteristics, are delineated with an exactness seldom seen in pieces of this kind. One of the merits of this line is that many of its subjects, while thoroughly artistic, appeal to people of all tastes. There is in them the ‘touch of nature’ which often does more to attract the buyer than does the artist’s or the sculptor’s skill. The line includes figures, single and in pairs, busts and groups, in sizes ranging from 6 inches to about 3 feet high.”  
—From *Jewelers' Circular*, Oct. 31, 1894.

believed it indirectly may have hastened his death. He was a heavy indorser of the company’s paper and lost many thousands.

When Mr. Lindemann assumed control of the watch works plant he incurred obligations amounting to \$100,000. The plant resumed operations under control of his nephew, Charles A. Klie.

Mr. Lindemann was a native of Zweibrucken in the Rheinkreis of Bavaria, where he was born Aug. 14, 1818. He had only been seriously ill a short time.

### Resolutions of Honor to Robert F. Simmons.

ATTLEBORO, Mass., Nov. 3.—During his long residence in North Attleboro, the late R. F. Simmons was a staunch supporter of the Attleboro Agricultural Association. For many years he was its president and at the time of death was a member of the Board of Directors. At the last meeting of the Board these resolutions were passed:

WHEREAS, The circle of our official board has been broken by the death of R. F. Simmons, duty and inclination prompt an acknowledgment of our loss, and of his worth therefore be it resolved that by his death the association has lost a good friend and a useful member, one who as President and Director, so long as his health permitted, gave his services freely, his wise counsel, and personal influence.

*Resolved*, That we mourn him as a man and a citizen, and shall ever hold him in grateful remembrance,

*Resolved*, That these resolutions be spread upon the records as a slight token of our high regard for him.

S. O. BIGNEY, President.  
GEO. RANDALL, Secretary.

WEST, WHITE & HARTMAN,  
80 FIFTH AVENUE,  
PITTSBURG'S NON-RETAILING JOBBING HOUSE.

DIAMONDS, WATCHES, JEWELRY,

ROGERS BROS.' 1847 FLAT WARE.

AGENTS DUEBER-HAMPDEN WATCHES.

WILL BE OPEN EVERY NIGHT IN DECEMBER.

# THE E. HOWARD WATCH & CLOCK CO.,

383 WASHINGTON ST., BOSTON. 34 WASHINGTON ST., CHICAGO.

41 MAIDEN LANE, NEW YORK.

◆◆◆◆◆

RETAIL JEWELERS:

GENTLEMEN--WE HAVE RECEIVED many letters from THE TRADE throughout the country from which we judge that an ERRONEOUS IMPRESSION has been given that HOWARD WATCHES cannot be obtained from Jobbers.

We therefore take this method of informing our friends, the Retail Jewelers, that any legitimate Jobber in the country can supply Howard Watches of ANY GRADE OR SIZE desired.

If your Jobber fails for any reason to fill your orders, write directly to us and we will see that you are supplied.

We have also received complaints that Retailers fail to get satisfaction when they send Howard Watches to their Jobbers for repairs, &c., and we earnestly request that any Retailer having trouble of any kind in regard to the PURCHASE, SALE or REPAIRING of our Watches, communicate directly with us.

We will gladly correspond with any dealer upon any point in connection with Howard Watches or Clocks.

The American Watch is the best watch in the world and WE HAVE ALWAYS MADE, ARE MAKING and WILL MAKE the finest American Watch.

We have a thoroughly organized Repair Department and will now do repair work on Howards at ACTUAL COST.

THE E. HOWARD WATCH AND CLOCK CO.

GENERAL MANAGER CARR,  
THE E. HOWARD WATCH CO.,  
383 Washington Street, Boston, Mass.:

} FALCON HARBOR, BOWDOIN BAY,  
} NORTH GREENLAND, Aug. 16, 1893.

DEAR SIR—It gives me much pleasure to acknowledge receipt of your three movements inclosed in aluminum cases as suggested by me. The three movements of your make which I used on the last year's trip to the Northern extremity of Greenland enabled me to return to the point of my departure, on the shore of McCormick's Bay, after a trip of some 1,300 miles, with a deviation of a trifle less than five miles. In the more compact and convenient form for the movements for the coming expedition I anticipate equally good results.

The fact that I take your movements again, is I think the strongest proof of my belief in them. I am,

Very sincerely yours,

Civil Engineer, U. S. N., Comd'g Expedition.

## Letters to the Editor.

EXPANSION OF THE DIAMOND CUTTING  
INDUSTRY IN AMERICA.

NEW YORK, Nov. 2, 1894.

Editor of THE JEWELERS' CIRCULAR:

Your editorial on the "Diamond Cutting Industry in America," in your issue of Oct. 31st, is full of interest and thoroughly exemplifies the present condition of the industry, and we fully concur in your opinion as to its future development.

It has by this time been clearly demonstrated, beyond any possible doubt, that diamonds for the American market can be cut and should be cut in the United States, and the introduction of such an important and valuable industry into the country should appeal to every merchant's patriotism and receive the encouragement which it deserves.

Yours truly,

STERN BROS. & Co.

THE POSITION OF FOREMAN POLISHER IN HOWARD STERLING CO.'S FACTORY.

PROVIDENCE, R. I., Nov. 2, 1894.

Editor of THE JEWELERS' CIRCULAR:

I see by announcement in your last issue of THE JEWELERS' CIRCULAR that Frank Fisher is reported as leaving Reed & Barton to take a position as foreman polisher at Howard Sterling Co; it is quite true that he is working at said place, but holds no position as reported, as I, Samuel Harrison hold the position as foreman polisher at the Howard

Sterling Co., Providence, R. I., and would like to have the mistake rectified. Likewise should be very much obliged if you would let me know where you got your information from. Hoping to hear from you, I remain  
Yours respectfully,

SAMUEL HARRISON.

### Providence Manufacturers who Retail Denounced.

PROVIDENCE, R. I., Nov. 2.—The second meeting of the legitimate retail jewelers of this city was held last evening at the Hotel Dorrance for the purpose of perfecting an organization. The meeting was well attended and was conducted by Newton Dexter.

The election of a president and five members of a board of directors was postponed until the next meeting, which is to occur a fortnight from last night on account of the absence of several out-of-town jewelers who are known to be in favor of this movement. The object is to have the county of Providence represented fully on the board of officers and for this reason elections to those positions were deferred. Jacob C. Farrington was elected vice-president, D. C. Fink, secretary and Sylvester Eastman, treasurer. A temporary constitution and by-laws were drawn up, but at the next meeting, permanent regulations will be presented and the plan of action discussed and mapped out.

Respecting the Providence manufacturers who retailed to the detriment of the jew-

eler, Mr. Dexter, said: "These men do not care whether they sell you their goods or not, as the bulk of their product is sold outside of the State, but when they begin to get protests, as they will, from the various retail associations throughout the country, they will realize that the craft means business."

### The Incorporation of the Jennings Mfg. Co.

NEWARK, N. J., Nov. 5.—The Jennings Mfg. Co. have incorporated with a capital stock of \$25,000 to manufacture, buy and sell jewelry and novelties.

The promoters are Chas. Michael, Chas. Hood, and John Jennings, of this city.

The partnership existing between Charles L. Dingler and William K. Rebert, Chester, Pa., has been dissolved. The business will be conducted by Mr. Dingler at the old stand, 824 Edgmont Ave.

A new jewelry store is to be opened in Palmer, Mass., in a short time. George W. Moore, formerly of Palmer, but now of Hartford, Conn., has engaged the vacant store in Holden's block and will put in a full line of jewelry.

Edward B. Fox has established himself at 1326 Chestnut St., Philadelphia, and will do a special optical business, namely filling prescriptions. He was formerly manager of Queen & Co.'s optical department, having held that post for the past ten years.

# Jno. W. Reddall & Co

*A Stock more attractive than ever.  
Replete with new and artistic conceptions in fourteen karat gold.*

MAKERS OF THE MOST POPULAR LINE OF  
SILVER MOUNTED BRACES AND BELTS.

107 HAMILTON STREET,  
Newark, N. J.

# The Jewelers' Circular

AND  
HOROLOGICAL REVIEW.

PUBLISHED EVERY WEDNESDAY BY

THE JEWELERS' CIRCULAR PUB'G CO.,  
189 BROADWAY, NEW YORK CITY.

A JOURNAL DEVOTED TO THE INTERESTS OF  
JEWELERS, WATCHMAKERS, SILVERSMITHS,  
ELECTRO-PLATE MANUFACTURERS, AND ALL  
ENGAGED IN KINDRED BRANCHES OF INDUSTRY.

Our Editorial columns will contain our own opinions only, and we shall present in other columns only what we consider of interest or value to our readers. Advertising matter will not be printed as news.

Advertising rates in THE CIRCULAR are lower, considering the number of tradesmen reached by its large circulation, than in any other jewelry journal.

Notices of changes in standing advertisements must be received one week in advance; new matter can be received up to Monday.

## INFORMATION FOR SUBSCRIBERS.

### Terms of Subscription, Postage Prepaid.

	PER ANNUM
United States and Canada, . . .	\$2.00
Foreign Countries in Postal Union, . . .	4.00
Single Copies, . . . . .	.10

New subscribers can commence at any time.

Payments for THE CIRCULAR, when sent by mail, should be made in a Post-Office Money Order, Bank Check or Draft, or an Express Money Order or Registered Letter. All postmasters are required to register letters whenever requested to do so.

Pay money only to authorized collectors having proper credentials.

Returning your paper will not enable us to discontinue it, as we cannot find your name on our books unless your address is given.

In changing address always give the old as well as new one. Your name cannot be found on our books unless this is done.

We will continue to send papers until there is a specific order to stop, in connection with which all arrearages must be paid; but such an order can be given at any time, to take effect at the expiration of the subscription. All such orders will be promptly acknowledged by mail.

The Courts have decided that all subscribers to journals are responsible until arrearages are paid in full and an order to discontinue has been received by the publisher.

Member of the American Trade Press Association

VOL. XXIX. Nov. 7, 1894. No. 15.

**T**HE Retail Jewelers' Association of Hartford have been prompt in entering upon their crusade against illegitimate practices militating against the probity and advantage of the jewelry trade. They have landed one watch lottery operator in court, and his case should possess for him a lugubrious hue. Keep up the good work, gentlemen, and have no mercy for any schemer who defies the law.

**The Demand for Fine Jewelry.** FROM a thorough inquiry among the jewelry manufacturers of Newark, N. J., it is to be inferred that business is very good, the factories working on full time with a full force of employes. Some of the factories are running till 9 o'clock at night and cannot fill orders fast enough. It is asserted that the jewelry business is better now than it had been for several years. The factories of Newark produce gold goods almost exclusively, and thus is given further evi-

dence of the truth of a statement in these columns recently, that it is a noticeable fact that there is a large business being done in the better and more expensive grades of jewelry.

### Protecting a Jeweler's Stock.

**T**HE circumstances surrounding the death of the boy, Stuart England, in the jewelry store of Bernard Goldstein, Utica, N. Y., have attracted a great measure of attention from the press. The incident illustrates the danger of meddling with electricity. This force has many uses, but it is a dangerous policy to try and multiply them beyond a reasonable point. An agent so swift in action and so certainly fatal as the current from an electric arc light should be guarded with more precaution than the most deadly of poisons. As we understand the case, Mr. Goldstein's store was burglarized last Spring, and seeking to guard against such mishaps in the future, he ran a strong current to the knob of his safe door. It was his custom to turn on the current when he left his store, thus setting a trap for enterprising felons. Young England visited the store and being "dared" by another lad to touch the knob, did so, receiving a shock that was instantly fatal. The mechanism of the electric appliance had become deranged. The jeweler has been arrested charged with manslaughter in the second degree, and the trial will be followed with interest by all jewelers who have the picture ever before their minds of awaking one morning to find their stock carried off. Mr. Goldstein was justified in taking precaution against the operations of the "enterprising burglar," but his anxiety led him to adopt means altogether too dangerous. If it were certain that only a burglar would suffer through such a contrivance as the jeweler constructed, he would have been fundamentally right in employing it, as in having a vicious dog on his premises. But electricity is a force whose mystery has not been entirely solved; the most seemingly perfect contrivances become deranged, and too often an innocent victim is found.

### What Constitutes Evil Intent.

**A** DECISION of interest to all manufacturers of jewelry and silverware was rendered in Baltimore, Md., a few days ago, by Judge Harlan, in the case of Samuel Kirk & Son against a former employe, Peter H. Keelan, charged with stealing six spoons. As last week reported in THE CIRCULAR, Keelan acknowledged that the six spoons were made by him from the firm's silver for the wife of a fellow employe, an engraver, but that he had no intention of stealing the spoons, and had returned to the firm eight ounces of silver clippings given him by the lady, as an offset. The legal point involved was that of felonious intent, which must be present to constitute larceny. The Judge

rendered a lengthy oral opinion, in which he ruled that it was clearly proven that the silver in the spoons belonged to Kirk & Son, and that the spoons had never, by the firm's consent, passed out of their possession. This constituted the two elements of taking and carrying away. As to the fraudulent intent, that was shown by the surroundings of the transaction. The prisoner had substituted, as he claimed, an equal amount of clippings, but he did it secretly and must have known that Kirk & Son would not have made any such exchange, if the firm had been asked to do so. And the man himself, as a silversmith, must have known he was taking something away for which he had not left equivalent value. As to its being shown that he did not intend to steal, by the fact of his leaving the clippings, he knew that he had to account, by weight, for silver received from the firm. Neither was there anything in the point advanced that he didn't intend to reap any benefit himself; it was just as much larceny to steal to make a present of the thing stolen as for himself. If he had no consciousness of wrong, he would have said at once just what he finally had to admit. The man was decided guilty.

### Jewelry and Department Stores

**T**HE objects of the Retail Jewelers' Association recently formed in Providence, R. I., seemed to be aimed particularly against those jewelry manufacturers who sell their products to the dry goods and notions trades. In a call upon several of the prominent manufacturers, for the purpose of obtaining their views upon the subject of this retail combine, it was learned that a majority of them could not understand what the retailers expected to gain or how they were going to work, when they had made up their minds to action. One gentleman stated that the three largest dry goods stores in Providence bought and used more jewelry in one month than all the retail jewelers of the city did in a whole year and, that they kept nearer a fair profit selling price than did the very ones who were now endeavoring to rectify so called abuses. These houses paid almost spot cash while the retailers invariably kept the manufacturers waiting for months for their money and then want to pay with an extension note. As a rule the manufacturers pooh-pooh at the movement. The truth of the foregoing statements is difficult to combat, and stands as an obstacle in the way of the realization of the jewelers' reform idea. Argument and combination can achieve little, for manufacturers will ever, as a rule, accept the readiest market for their products. We do not approve of the universal employment of this theory of business, and think, that the manufacturers who sell to the department stores, goods above certain grades will suffer ultimately for their enterprise.

### New York Notes.

Alois Kohn & Co. have entered a judgment for \$78.50 against Frank Simon.

A judgment against Jno. E. Jarck for \$154.27 has been filed by H. L. Judd & Co.

Helene Gordon, 113 Eighth Ave., has given a chattel mortgage on jewelry fixtures to D. I. Seiffer for \$200.

Antoine Le Coultré, watchmaker, has hired an office on the 11th floor of the Sheldon building, 68 Nassau St.

A judgment for \$117.50 against Samuel A. Prince and Geo. H. Schone has been entered by C. F. Nesler and Wm. G. Nerpel.

The engagement is announced of Mortimer Thiess, with J. Dreicer & Son, Fifth Ave. and 28th St., to Miss Jacobs, daughter of Mr. and Mrs. H. R. Jacobs.

A reception will be held by the Watchmakers' & Jewelers' Benevolent Association next Saturday evening at the Central Opera House, 67th St. and Third Ave.

Theodore Bloecher, with R., L. & M. Friedlander, has just been appointed a school commissioner in Carlstedt, N. J. He is a member of the Board of Councilmen, as well as Chief of Police in that town.

John R. Howard has succeeded S. H. H. Penton, as watch case maker and polisher, 38 Maiden Lane, having purchased the plant, good will, etc., of Mr. Penton's business. Mr. Howard was formerly employed by the St. Louis Watch Case Co.

S. L. Van Wezel, of the diamond cutting firm of that name in Amsterdam, Holland, was in this city last week. Mr. Van Wezel is here, it is said, with the view of making arrangements for the establishment of a diamond cutting plant in this country.

Judge Newberger, in the City Court, Thursday, granted a motion for a receiver for Isaac Boltansky, formerly a retail jeweler at 2659 3d Ave., in supplementary proceedings brought by Hipp Didisheim. Mr. Didisheim is a judgment creditor for \$532.90.

Three actions in the City Court against Wm. Downey have been settled. One by Carter, Sloan & Co. for goods sold and delivered, and two by Lippman Tannenbaum for money loaned and notes due, were discontinued Friday by Judge Newberger.

On Thursday morning the funeral of Charlotte Rhodes Fellows took place at her late residence, 166 W. 126th St. Mrs. Fellows died Tuesday, Oct. 30th. She was the widow of John P. Fellows, of Fellows & Co., whose death occurred about a year ago.

A leak in the water pipe in the basement of the building occupied by R., L. & M. Friedlander, 30 Maiden Lane, caused considerable damage last week. As all the goods were on shelves, the stock was uninjured. Plumbers soon arrived and the damage was repaired.

The suit in the City Court of the Jno. A. Roebbling's Sons Co. against the American Watchman's Time Detector Co. has been settled. An order discontinuing the action was signed by Judge Newberger, Oct. 30th. The action was to recover \$151 for wire sold the defendant company.

Tiffany & Co. are offering \$300 reward for a pear-shaped diamond in a light gold setting with a small hook at the back. It was lost about three weeks ago. They also offer \$20 for the return of a gold enamelled butterfly brooch, set with three rose diamonds, which was lost Oct. 29, on Fifth Ave. between 29th and 30th Sts.

Judge Townsend, in the United States Circuit Court Wednesday, signed his decree dismissing without costs the suit brought by Chas. M. Levy against Dattelbaum & Friedman. The action was to restrain the defendants from manufacturing an interchangeable initial ring patented by Otto Thie and Chas. M. Levy.

It is desirable to state that the judgment for \$103.17 reported obtained last week against Henry Carter by the Wightman & Hough Co., was granted by default, through the absence south of Mr. Carter. It was satisfied immediately upon his return to New York, and we feel assured the proceedings will not injure Mr. Carter's good credit in the trade.

On application of Gottfried C. Hartdegan, a judgment creditor for \$35.15, a motion for a receiver for Adolph Bechtold and Jos. J. Clairmont, partners in the defunct optical firm of Clairmont & Co., was granted by Judge Geigerich in the Court of Common Pleas last week. The motion was granted with \$15 costs and Jos. H. Spellman, the present receiver of Clairmont & Co., was appointed receiver in this action.

### The Attleboros.

C. E. Sandland, in the Draper building, has opened a shop in Providence.

David S. Manney and S. B. Segree, of New York, were buyers here last week.

For the Pawtucket city election the Democrats nominated David J. White, of the Standard Seamless Wire Co., for alderman.

Mr. and Mrs. Frank M. Sturdy have returned from their wedding tour in the west. Mr. Sturdy is a member of the firm of J. F. Sturdy & Sons.

The cutlery and table novelty manufactory of Matthew George, Mansfield, was destroyed by fire Wednesday. The loss was \$4,000, partially insured.

At the meeting of the Bi-Centennial committee Thursday night, the success of the affair was reported to the taxpayers and and the statement made that the expenditures were within the appropriation.

The *Adrian Weekly Press* of Nov. 2d, contained a highly complimentary notice regarding Wm. M. Sheldon and his optical and jewelry store in Adrian, Mich.

### Providence.

Louis Kern, formerly of Kern Bros., is now in the employ of S. & B. Lederer.

Ezra S. Dodge has been appointed administrator of the estate of E. Spencer Dodge; bonds \$1,000.

Nathan B. Barton, of Ostby & Barton Co. has been appointed a member of the finance committee of the Rhode Island Business Men's Association.

George C. McCormick & Co., 228 Butler Exchange, has the control in this city of the latest novelty, the Boston Baked Bean pepper and salt souvenir.

Louis Cohn has given a chattel mortgage on stock and fixtures at 667 Westminster St., to Solomon Hopman, of Lawrence, Mass. The amount is \$800.

The employes of the Kent & Stanley Co. have organized themselves into a social club and propose during the coming Winter to hold several festive gatherings.

Henry C. Tilden, son of Henry Tilden of the Tilden-Thurber Co. was united in marriage to Miss Flora B. Steiness, daughter of Justice John H. Steiness, Judge of the Rhode Island Supreme Court, on Thursday last.

Among the supervisors appointed for the municipal election were: Republicans, 1st Ward, P. S. Bliven; 5th Ward, Louis Schmitt; 4th, Edward Xavens and J. C. Harrington; 8th Ward, Telesford Stahl. Democratic, 6th Ward, Thomas W. Feeley.

The Kent & Stanley Co. announce the completion of their new manufacturing building on Aborn, Sabin, Mason and Beverly Sts., and extend a cordial invitation to the public to be present on the 8th inst., from 10 o'clock till 5, to attend the grand opening and inspect this, the largest building for rental in the State of Rhode Island. Reeve's American Band will give a band concert.

Attorney Clark H. Johnston, assignee of William L. Ballou & Co., completed taking an inventory of the stock and fixtures of the retail branch, at the corner of Westminster and Mathewson Sts., the past week. He will commence his labors on the manufactory, on Warren St., and expects to have his schedule of assets and liabilities ready in a few days. The retail store has been opened and an "assignee's marked down sale" is now in progress.

Dunn & Ellis, Jonesboro, Ark., have been succeeded by T. J. Ellis & Co.

Earnest Elmer, Muskegon, Mich., has received a mortgage for \$1,450.

R. L. Wells, Sprague, Wash., has given chattel mortgages for \$91 and \$206.

F. J. Hartley, Kansas City, Mo., has given a warranty deed on realty for \$1,200.

Valentine Gentner, Jr., Buffalo, N. Y., has a judgment entered against him for \$155.

The receiver of Simon Rumpf, Seattle, Wash., has given a bill of sale on stock for \$5,000.

**Last Week's Arrivals.**

*THE CIRCULAR has perfected arrangements for obtaining the names and hotel addresses of all the latest buyers visiting New York, and each day posts in its office, 189 Broadway, a bulletin which every member of the trade is cordially invited to copy.*

The following out-of-town dealers were registered in New York during the past week: C. H. Place, St. Albans, Vt., Astor H.; C. Spandau, Pittsburgh, Pa., Westminster H.; D. Benninger, Tamaqua, Pa., Sinclair H.; J. De Roy, Pittsburgh, Pa., Astor H.; E. H. True, Montrose, Pa., Astor H.; E. F. Jakeman, Norfolk, Va., St. Denis H.; L. C. Roessler, Cumberland, Md., St. Denis H.; W. E. Carter, Portland, Me., St. Denis H.; J. W. Spence, Racine, Wis., Astor H.; C. W. Bixler, Easton, Pa., Astor H.; J. Grafner, Pittsburgh, Pa., Imperial H.; H. Eliassof, Albany, N. Y., Imperial H.; J. McDonough, Albany, N. Y., Sinclair H.; C. H. Osgood, Lewiston, Me., Astor H.; J. R. Ferguson, St John, N. B., Astor H.; G. Rudisill, Altoona, Pa., Astor H.; G. H. Herrick, Attleboro, Mass., Astor H.; F. W. Bragg, Rutland, Vt., Astor H.; H. M. Rudert, York, Pa., Astor H.; W. Glover, Jr., Hazelton, Pa., Marlborough H.; J. A. Wetherell, Parkersburgh, W. Va., St. Denis H.; T. J. Wetherell, Parkersburgh, W.

Va., St. Denis H.; R. L. Galt, Washington, D. C., Imperial H.; J. T. Veil, Stamford, Conn., Grand Union H.; W. Bausch, Rochester, N. Y., Murray Hill H.; H. C. Tilden, Providence, R. I., Murray Hill H.; D. R. Brown, Stroudsburg, Pa., Broadway Central H.; A. Field, AsLeville, N. C., Astor H.; F. M. Dodge, Boston, Mass., Grand Union H.; M. F. Robinson, Springfield, Mass., St. Denis H.; L. S. Stowe, Springfield, Mass., Grand Union H.; J. B. Knight, Boston, Mass., Morton H.

**Pittsburgh.**

L. J. Selezvick has opened a store at 131 Fifth Ave.

Louis Weinburg, for 14 years manager for Kaufman Bros., is now with B. E. Arons.

George Thompson, whose father was killed by the traction road, has entered suit for \$20,000.

Maurice Baer will leave this week for a five weeks' eastern trip of business and pleasure combined.

Phillip Gillespie, one for Heeren Bros. & Co.'s old clerks, will leave this week to engage in other business.

J. M. Stoner, Jr., has entered suit against the Suburban Rapid Transit Railway for \$3,000 damages for injury to property.

Frank Weylman, Kittanning; Harvey Wallace, Smith's Ferry; W. W. Mather, Belle Vernon; Mr. Bygate, Bygate & Co.,

and Chas. Kennerdell, Freeport, were in the city last week.

Goddard, Hill & Co.'s suit against Leopold Weil & Co., of New York, not Leo Weil & Co., of Pittsburgh, as stated in local papers, was an action on an execution for \$1,600 held against John Black, of Allegheny. Weil & Co. sold out Black, while Goddard, Hill & Co. held his previous execution.

Travelers visiting Pittsburgh, last week were: Cliff Booth. Hutchison & Huestis; G. I. Benedict, Geneva Optical Co.; J. S. Roberts, Waterbury Watch Co.; W. Bippart, J. Ollendorf; Simon Adler, B. H. Davis & Co.; Mr. Kohn, S. Valfer & Co.; Lawrence H. Smith, Bippart & Co.; Mr. Sylvia, Mt. Washington Glass Co.; W. R. Bristol, C. Rogers & Bros.; Albert Zugsmith, J. N. Provenzano; Edward Todd, Jr., Edward Todd & Co.; D. Skutch, Waterbury Clock Co.; Geo. W. White, William S. Hicks' Sons; N. Herskovits, Empire Cut Glass Co.; Charles F. Ketcham, Riker Bros.; W. H. Bryant, T. G. Hawkes & Co.; Eph. A. Karelsen, M. D. Rothschild; Mr. Pickering, Shoemaker, Pickering & Co.; Mr. Melcher, Bennett, Melcher & Co.; Arthur Bradshaw, Meriden Britannia Co.; F. L. Goddard, Geo. W. Shiebler Co.; L. H. Bosworth, Potter & Buffinton; Mr. Posner, Wallach & Schiele; J. Williams, for G. Armeny; G. Hofman, Ansonia Clock Co.; W. R. Eliot, J. D. Bergen Co.; A. Peabody; E. C. Holbrook.

**THE INCREASED DUTY ON****DIAMONDS****HAS NOT INCREASED OUR PRICES.**

Mr. L. Tannenbaum on his last trip having purchased and bought over under the old duty over five times his usual quantity of the finest Diamonds, Rubies, Sapphires, Emeralds, Opals, Pearls, and other Precious Stones and Melles, he will continue to sell to the trade for the next six months, at prices governed by the old rate of 10 per cent. being thus a clear gain of

**15 PER CENT.**

to dealers who place orders NOW.

This is an Opportunity of a Lifetime. These Goods are the Finest and Cheapest in the Market To-Day.

**L. TANNENBAUM & Co.,**  
**Importers and Cutters of Diamonds and Precious Stones,**  
**COR. MAIDEN LANE & NASSAU ST., NEW YORK.**



## Our Traveling Representatives

Traveling representatives may consult these columns open for the publication any news or items of interest regard themselves or their conferees.

**T**RAVELING men calling upon Davenport, Ia., jewelers the past week were: Frank Thompson, F. Kroeber Clock Co.; E. Henry Silas, L. Manasse; and J. H. McCormick, Waterbury Clock Co.

Louis Moss, with R., L. & M. Friedlander, 30 Maiden Lane, New York, who is at present in Pennsylvania and Abe Harris, traveling for the same firm, report very good trade.

C. F. Coutts, for G. A. Webster, Chicago, left Thursday for a northwestern trip. The "Commodore" arrived at 9 A. M., after a two months' trip, and was again on the road at 9 P. M.

Travelers in Cincinnati last week homeward bound were: E. I. Rogers, Parks Bros. & Rogers; Clifford Borth, Hutchison & Huestis; H. A. Scofield, Lincoln, Bacon & Co.; Baron Kennion, H. D. Merritt & Co.; and Dr. Heffron, Riley, French & Heffron.

Salesmen who dropped into Philadelphia the past week were: Tom Frothingham; F. Woods, Carter, Sloan & Co.; Ed. Eck-

## THEODORE C. STEINHAUS,

— MANUFACTURER OF —

## Fine Cases and Trays

For JEWELRY, SILVERWARE, &c.  
SAMPLE CASES AND TRAYS FOR TRAVELERS.  
Fancy Hard Wood Chests for Silverware, &c.  
Linings, Cushions, Mounting, etc., for Silver Novelties.

10 MAIDEN LANE, NEW YORK.

feldt, W. B. Kerr & Co.; F. Day, Day & Clark; C. Imfeld, O. A. Hendricks & Co.; C. Duffy, Enos Richardson & Co.; Otto Wolff, Bippart & Co.; R. Thompson, for Henry Glorieux; D. Young, Cox, Cooper, Ward & Young; J. Parker, Bassett Jewelry Co. and F. Osborne, Wm. Smith & Co.

The following traveling salesmen passed through Detroit last week: C. C. Offerman, William Smith & Co.; P. Convert, of Convert & Maissiat, Paris; S. Young, Maybaum & Stein; Jule Franklin, L. Tannenbaum & Co.; Mr. Stern, Young & Stern; Mr. Colwell, Plainville Stock Co.; Mr. Cook, The Woodman-Cook Co.; Matthias Stratton, Jno. W. Reddall & Co.; F. H. Carpenter, Alfred H. Smith & Co.; F. C. Allen, for A. Wittnauer; Edward Todd, Edward Todd & Co.; O. C. Lane, Reed & Barton; W. F. Corey, Corey & Osmun; Harry Osborne, Whiting Mfg. Co.; C. Pettit, Hayden Mfg. Co.; Frank Schonreek, Deitsch Bros.; C. W. Cary, J. B. & S. M. Knowles Co.; and Mr. Arnstine, Arnstine Bros. & Mier.

Knights of the grip noticed in Syracuse, N. Y., during the past week were: S. D. McChesney, Wm. B. Kerr & Co.; J. Guntzburger, C. Cottier & Son and Martin Frank & Co.; Mr. Cobb, W. R. Cobb & Co.; Geo. W. Mindil, American Watch Case Co.; Wm. H. Pullman, for Charles Knapp; Mr. Van Pelt, for S. Lindenborn; Mr. Whiting, S. E. Fisher & Co.; J. R. Palmer, Palmer & Peckham; Chas. Van Ness, Reeves & Sillocks; V. W. Henderson, Enos Richardson & Co.; E. Horton, J. B. Bowden & Co.; F. Frank Davis, Hipp. Didisheim & Bros.; S. Cohn, Oppenheimer Bros. & Veith; J. N. Beckwith, Jos. H. Fink & Co.; Jas. Pantan, Mabie, Todd & Bard; E. H. Cox, Sussfeld, Lorsch & Co.; Henry Heyman, Koch, Dreyfus & Co.; Wm. S. Eaton, Aikin, Lambert & Co. and Spencer Optical Mfg. Co.; Frank A. Averbek, Averbek & Averbek; W. J. Carrow, Mandeville, Carrow & Crane; S. C. Corbin, Waterbury Clock Co.; John Blair, Blair's Fountain Pen Co.; Mr. Williams, Barstow & Williams; J. Fowler, Fowler Bros.; M. Adler; Mr. Wightman, R. F. Simmons & Co.; Mr. Miller, Pairpoint Mfg. Co. Riker Bros. and R. Fleig & Co. were also represented.

Among the travelers in the Hub the past week were: Henry Tallman, Irons & Russell; S. O. Bigney; Mr. Kurtz, G. W. Cheever & Co.; J. M. Fisher; Mr. Inman, J. T. Inman & Co.; Chris Morgan, Rogers & Brother; W. S. Metcalfe, Plainville Stock Co.; E. W. Martin, Martin, Copeland & Co.; Louis Jones, R. F. Simmons & Co.; W. J. Carrow, Mandeville, Carrow & Crane; Herbert Barker, J. W. Reddall & Co.; William H. Jones, Larter, Elcox & Co.; Mr. Cook, J. F. Fradley & Co.; Hermann A. Friese, Lewis, Kaiser & Luthy; Otto Wormser; G. B. Osborne, Wm. Smith & Co.

Among the jewelry men who have visited Springfield, Mass., within the past few days were: G. B. Osborne, Wm. Smith & Co., who, by the way, is a new man on this route, but an old one in the work; J. A. Cheney, Ludwig Nissen & Co.; E. Kubie, Levy, Drefus & Co.; Mr. Weil, S. Valfer & Co.; A. Rutherford, Kirby, Mowry & Co.; Geo. B. Nagle, Globe Optical Co.; H. Green, H. C. Hardy & Co.; C. H. Buxton, Gorham Mfg. Co.; L. Nolph, Louis Wolfsheim; John A. Abel, Lewis, Kaiser & Luthy; E. H. Eckfeldt, Wm. B. Kerr & Co.; A. Weilman, L. H. Keller & Co.; W. J. Campbell, Day & Clark; William H. Jones, Larter, Elcox & Co.; E. Horton, J. B. Bowden & Co.; Chas. W. Noyes, Ehrlich & Sinnock; R. T. Supple, Wm. B. Durgin; Mr. Baker, Reed & Barton, A. A. Wood, Howard Sterling Co.; G. B. Midlen, Gorham Mfg. Co.

### The Missouri Legislature Petitioned to Restrict Auctioneers.

ST. LOUIS, Mo., Nov. 1.—The Retail Jewelers' Association of Missouri have drafted resolutions asking the Legislature to more practically define the duties of jewelry auctioneers and to prohibit auctions at night in St. Louis stores.

Legal talent has been engaged to push the cause.

### Jeweler Goldstein Charged with Manslaughter.

UTICA, N. Y., Nov. 1.—Bernard Goldstein, the South St. jeweler, at whose store Stuart England met his death by electricity, was arrested and arraigned in the City Court charged with manslaughter in the second degree on complaint of Chief of Police Chas. M. Dagwell, upon the request of District Attorney Klock. Judge Morehouse presided, and District Attorney Klock appeared for the people. Goldstein pleaded not guilty, and was held until Dec. 4th for examination. Bail was fixed at \$2,000, and William Howarth and R. Owen Jones, both in business on South St., signed as sureties.



## The St. Louis Ophthalmic College and Hospital

A SCHOOL OF THEORETICAL AND APPLIED OPHTHALMIC OPTICS.

1655 SOUTH JEFFERSON AVENUE,

N. W. Corner Lafayette Avenue, ST. LOUIS, MO.

For the Announcement and further information, address Ignatz Mayer, M. D., President.

## Jules Jürgensen

OF COPENHAGEN.

The reputation these watches have maintained for Fifty Years has never been equalled, being made on strictly scientific principles and no expense spared to give the Best results in mechanism and timekeeping qualities.

SOLE AGENTS,

John C. Hyde's Sons,

NO. 22 MAIDEN LANE.



## H. H. HEINRICH,

14 John St., N. Y.

MARINE

## Chronometers

for Rent and Sale.

Large Stock on Hand.

Springing, Readjusting and Repairing for the trade.

Easy Terms. Send for Price List.



## THE PHILADELPHIA COLLEGE OF HOROLOGY

A practical school to learn watch-making, engraving, jewelry repairing and optics. One tuition pays for all branches. Send for prospectus.

F. W. SCHULER, Principal.

No. 623 HEED BUILDING, PHILADELPHIA, PA.



**Boston.**

A. D. Cairns has been elected secretary of the local British Charitable Society.

E. Frank Wilson is located at 351 Washington St., and has started as a jewelry trade auctioneer.

General Manager Rufus B. Carr, of the E. Howard Watch & Clock Co., is on a business trip to New York and Chicago.

George Howland, who was head of the silverware department at Wilson Bros., has left the firm's employ, and G. W. Hopkins takes his position.

Nathan Baer, the jeweler who twice attempted suicide recently, is still alive at the hospital. The bullet in his head has not been removed. His case is on the dangerous list.

George H. Whitford, who in addition to his Boston store has had an interest in a store at Waltham, in which city he resides, has disposed of his interest in the Waltham place to his partner, Mr. Johnson.

L. H. Green, formerly at 339 Washington St., and recently established in business in Boston, having removed to this city from Los Angeles, Cal., has taken quarters with Dr. D. J. Ingraham, optician, 367 Washington St.

Buyers in town the past week included: O. F. Hall, South Norridgewock, Me.; E. R. Blethen, Foxcroft, Me.; D. W. Moses, Plainfield, Vt.; Col. C. H. Osgood, of H. A. Osgood & Son, Lewiston, Me.; J. Ferguson of Ferguson & Page, St. Johnsbury, Vt.

In the case of the Archer & Pancoast Mfg. Co., of Illinois, against the Northwestern Hardware Co., of Pennsylvania and Schreve, Crump & Low Co., Boston, the Superior Court Justice has decided that receivers of a foreign corporation cannot prevail against another foreign corporation which has attached the property of their corporation within this State to have it applied to the payment of its claim.

Ralli Bros., jewelers, East Boston, are to have a post clock, 12 feet high, with two conspicuous dials. The timepiece will be of the E. Howard make. The E. Howard Watch & Clock Co. are to furnish a striking tower clock with four 7 feet dials for the Macon County Court House, at Oglethorpe, Ga. For Maicas & Co. the corporation is constructing a tower clock, chiming on four gongs, for shipment abroad. Still another order is for a tower clock with three 4 feet dials on Mt. St. Francis convent at Peekskill, N. Y. The clock is arranged so as to strike the Angelus. The largest clock recently ordered from the works however, is for the Union depot, at Denver, and will have four 11½ ft. illuminated dials.

The Baird building, Kansas City, Mo., was almost totally destroyed by fire on the night of Oct. 25. Among the occupants was B. Levin, jeweler.



OUR  
**CANE**  
Stick  
And  
Lapel  
Pins.

PATENTED  
OCT. 23,  
1894,  
ARE  
THE  
PROPER  
THING.  
HEADS  
ARE  
OF  
SOLID  
GOLD  
OR  
STERLING  
SILVER,  
Artistically  
CHASED.  
STICKS  
ARE  
ENAMELED  
TO  
REPRESENT  
NATURAL  
WOODS.

**WAITE,  
THRESHER  
COMPANY,  
PROVIDENCE, R. I.**

Waite,  
Thresher  
Company,  
Providence, R. I.

THEY SELL AT  
SIGHT.



**DIAMONDS.****Wm. S. Hedges & Co.,****Importers of Diamonds,**

And Manufacturers of DIAMOND JEWELRY.

**170 Broadway, New York.**

22 Holborn Viaduct, London.

**Alfred H. Smith & Co.,****IMPORTERS****DIAMONDS**

AND

**PRECIOUS STONES,****82 BROADWAY, COR. JOHN STREET,****NEW YORK.**

22 Holborn Viaduct, London, E. C.

**R. A. KIPLING,****Precious Stones**

AND Fancy Goods

**Bought and Sold on Commission.****19 RUE DROUOT,****PARIS, FRANCE.****O. NEWMAN,**

Successor to L. NEWMAN.

GOLD and...

...SILVER

**PLATER,****75 & 77 Nassau St, N. Y.**

Owing to the death of my father, I beg leave to notify our customers and the trade that the business will be continued by me at the old stand with new improvements, which will produce better results

Etruscan Coloring a Specialty.

**Philadelphia.**

James D. Hughes, of L. A. Scherr & Co., who has just returned from a business trip through the State reports business as "booming."

George W. Long, 118 S. 7th St., has been appointed to the agency for Pennsylvania of the United States Watch Co., Waltham, Mass.

Miss Clara Zeigler, who has been in the employ of L. A. Scherr & Co. for about seven years, has given up her position in that establishment.

Out-of-town purchasers here during the part week were: John Denver, Bryn Mawr, Pa.; C. F. Rudolph, Wilmington, Del.; E. Keifer, Pottstown, Pa.; John Steel, Carlisle, Pa.

**Syracuse.**

Jeweler C. M. Knowlton, of Cazenovia, was in town last week.

E. G. Seymour has returned from a ten days' stay in New York.

Northern New York has been receiving the undivided attention of W. P. Hitchcock, of Hitchcock & Morse, the past week.

Charles L. Becker returned Thursday afternoon with a smiling face and the best of luck from two days' duck shooting on Oneida Lake.

Chief Wright thinks that A. H. King, Charles M. Hastings and Marcus Marks are the men who stole the tray of diamonds from Becker & Lathrop's jewelry store, in Syracuse recently. They are believed to be in Washington. These men were registered at a Syracuse hotel at the time the robbery occurred and left immediately afterward.

C. E. Eager and twenty-four other jewelers entered a protest against an auction sale of jewelry at 334 N. Salina St., on the ground that such sale is being conducted against the law, as the stock was owned by out-of-town persons and was merely under the control of auctioneer D. D. Candee. The petitioners asked for an investigation and an enforcement of the laws applicable in the case. The matter was referred to the Corporation Counsel and the Committee on Rules and Ordinances.

Shortly after midnight on the morning of Oct. 29 a stone was thrown through the window of James Logan's jewelry store, 1115 St. Clair St., Cleveland, O., and a tray of rings taken by some unknown person. The rings were valued at \$6 and the window at \$100.

*Waterman and Schumann,*  
Manufacturers of  
**Diamond Jewelry**  
AND DEALERS IN  
**Diamonds.**  
*No 37 Maiden Lane*  
*New York.*

**KELLER, ETTINGER & FINK,**

SELECTION ORDERS SOLICITED.

**24 JOHN STREET, NEW YORK.**

DEALERS IN

MOUNTERS OF

IMPORTERS OF

**American Watches.****Fine Diamond Jewelry.****Diamonds.**

**Canada and the Provinces.**

C. L. Von Gunten, of the firm of Von Gunten Bros., jewelers, Chatham, Ont., died last week.

W. S. Walker & Co., Montreal, have the contract for putting clocks in the cars of the Montreal Street Railway and are filling as quick as possible.

Simpson, Hall, Miller & Co., through their Montreal manager, A. J. Whimby, have donated two magnificent silver trophies valued at \$250 to be contested for at the coming military competition in Montreal in aid of the Free Coal Fund.

Alexander Ward Haugh's store, Belleville, was entered last Thursday by burglars, who stole about \$400 worth of watches and jewelry. The police arrested William Conlin and H. D. Marseler on suspicion. They were remanded for a week.

The Winnipeg Electro-Plating Co. is no longer in existence. Mrs. R. E. Heaman was the only proprietor and her husband, James Heaman ran the business under her name. They have both recently skipped out and are believed to be in Duluth. The sheriff is in charge of the store.

Thomas J. Gardiner, late with George M. Baker, Providence, R. I., is now engaged in the refining business on his own account with Edgar W. Guild under the style of Guild & Gardiner. The location of the new firm is 189 Eddy St., Providence, and they promise quick returns and excellent result.

Irons & Russell, Providence, R. I., have ready and are distributing their 1895 catalogue of emblems. It is an exceedingly artistic and comprehensive book of 250 pages, bound in cloth boards and containing nearly 3,000 illustrations. Gold and plated emblems are shown and indexed separately, and in the matter of indexing the book leaves nothing to be desired. The user at once ascertains the number, quality and variety of any desired line of emblems. A vest pocket price list of 75 pages also handily indexed, is an excellent adjunct.

The Bixby Silver Co., Providence, R. I., report a rapidly increasing business. The house carry a full line of the J. B. & S. M. Knowles Co.'s excellent goods and report large sales of the popular Argo and the new Apollo which has taken buyers completely by storm.

For holiday trade there is nothing more desirable than a well selected line of tortoise shell goods. The handsome pieces shown by Glickauf & Newhouse, 86 State St., Chicago, a few of which are illustrated in this issue, should commend themselves to the wide-awake jeweler and at the prices named are trade winners at good profit to the retailer. The designs are of the latest and the rapid growth of tortoise shell into public favor bespeaks large sales of these goods during the holidays. Glickauf & Newhouse have a fine line at bottom prices.

ESTABLISHED 50 YEARS.

LANDEL, BAREMORE & BILLINGS,

IMPORTERS OF

DIAMONDS,

AND OTHER PRECIOUS STONES.

FINE PEARLS A SPECIALTY.

MANUFACTURERS OF

DIAMOND JEWELRY,

IN THE LATEST DESIGNS.

Diamonds Recut in Modern Styles or Repaired on Premises.

58 Nassau Street,  
29 Maiden Lane,  
NEW YORK.

1 Tulp Straat,  
AMSTERDAM.

1 St. Andrews St.,  
Holborn Circus,  
LONDON, E. C.



TRADE MARK.

ESTABLISHED 1841.

CARTER, SLOAN & CO.,

MANUFACTURERS OF GOLD JEWELRY,

No. 15 MAIDEN LANE,

NEW YORK.

A. CARTER JR.  
A. K. SLOAN.  
C. E. HASTINGS.

GEO. R. HOWE  
WM. T. CARTER  
WM. T. GOUGH.

FACTORY, NEWARK, N. J.



JOHN N. DISSELKOEN,

Gutter and Importer of

DIAMONDS

FACTORY  
76 LANGBLEEKERSPAD  
AMSTERDAM.

19 East 16th St.,  
NEW YORK.

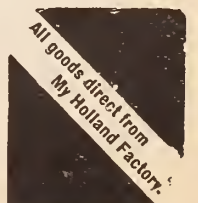

### News Gleanings.

W. W. Davis has opened a new store in Jersey Shore, Pa.

Henry Seele's store, Rolla, Mo., was destroyed by fire a few days ago.

J. A. McDonald has removed from Harper, Kan., to Anthony, Kan.

Harry F. Howe, Littleton, N. H., has removed to a better location in that town.

A. J. Rhein & Bros., San José, Cal., announce that they are going out of business.

Steward Laufer will remove from Wind Gap, Pa., to Quakertown, Pa.

H. C. Kachlein, Lafayette, Ind., has returned home from a business visit in New York.

George W. Custer, Du Bois, Pa., has been appointed watch inspector for the B. R. & P. railway.

H. G. Van Wagnen recently disposed of his interest in the jewelry business in Monroe, Wis., to N. A. Speck.

J. B. Keith, Jr., Spickards, Mo., has disposed of his stock of jewelry and notions to B. Lockheart, of Trenton, Mo.

E. Munson's new jewelry store, Earlville, Ill., of which N. O. Munson is the proprietor, was opened Oct. 30th.

Clark & Engle, manufacturing jewelers, Main St., Wilkesbarre, Pa., are making extensive improvements in their store.

Bernard Erb, a jeweler from Denver, Col., has opened a shop in the front part of the post office building, Alamosa, Col.

The American Waltham Watch Co. have restored the former rate of wages to the employes of the setting up department, about 100 in number.

Robt. Ernst, Vicksburg, Mass., has removed to a very commodious store in that city, formerly occupied by the National Bank.

Chas. Volkerts, Arton, Ia., now has a partner in the jewelry business, and says that they intend to put in a large stock of jewelry.

Col. Frank W. Stewart, Huntingdon, Pa., is on a trip to Randolph county, W. Va., to look after some interests in that wild country.

T. B. Zeller, jeweler, has purchased property on Walnut St., Brookville, Pa., and is improving it by erecting an addition thereto. He will occupy it soon.

Chas. K. Morgan, Titusville, Fla., died on the morning of Oct. 26, of typhoid fever. His mother left for Urbana, O., with the body, where it was interred.

Crisp & Henson, jewelers, Jefferson, O., have purchased a jewelry store in Cortland, N. Y., and G. L. Henson of the firm will soon move thither and take charge of the store.

Fred Crane has entered into partnership with his uncle, Hervey Crane, Mt. Pleasant, Ia. Mr. Crane has for some years been in Chicago, in partnership with Victor Rukgaber.

The interior of Frederick A. Fuller, Jr.'s jewelry store, Jamestown, N. Y., is being remodeled. When improvements are completed it will be one of the handsomest business places in the State.

At John Stark's factory, Waltham, Mass., 20 ballot boxes to be used in the State and municipal election, were last week completed. These boxes are known as the "Ideal," and were invented by John Quincy Adams.

Geo. Suhrer is making some repairs to the front of his jeweler's store on Central St., Fernandina, Fla., which, when completed, will still further enhance the beauty of what is already one of the handsomest show windows in town.

The Gloucester Electro-Plating Co. have formed in Gloucester, Mass., with quarters over Chrisholm's jewelry store. The officers of the company are: Walter H. Ropper, president; Thos. F. Counihan, secretary; John A. Cameron, treasurer and manager.

While the shades of night enveiled Washington, N. J., and while his creditors were sleeping soundly jeweler A. E. Saxton last Thursday night took French leave of that place. His goods were mortgaged for more than their full value. The stock of the store is in the possession of Chas. A. Miller.

While sowing rye in his field on the morning of Oct. 30th Samuel Harrison, an aged watchmaker of Vineland, N. J., dropped dead, and was found by his son an hour later. Mr. Harrison was a native of England, where for years he was employed as a railroad engineer.

To-day, Nov. 7, Mr. and Mrs. Edwin Styles, Rhinebeck, N. Y., celebrate their golden wedding. The Rhinebeck jewelry establishment was founded in 1794 by James Styles, Sr.; from 1820 to 1870 it was conducted by Wm. J. Styles, while the present proprietor is Edwin Styles. To our knowledge this is the oldest jewelry business in America.

Charles A. Aughinbaugh, Harrisburgh, Pa., has been at his home suffering with a broken nose, shoulder bone, two ribs and a two and a half inch gash in the side of his head. On the morning of Oct. 26th he was climbing a ladder to inspect his roof, which had been repaired, when the ladder broke and he fell over 15 feet, falling on his side on a cellar door, and he was unconscious for some time.

### Buffalo.

King & Eisele are sending out one of their snap lists and are working full time with full set of hands in their factory.

Crisp & Henson, Jefferson, O., have bought the business of Mrs. Gray, Cortland, N. Y., and intend to run it as a branch of their Ohio store.

King & Eisele last week obtained judgment against J. B. Woodbury as principal, and C. W. Griswold, as agent, both of Hornellsville, N. Y., for \$193.44 and costs, after a tedious trial of several days duration.

The following out-of-town jewelers were here last week: W. W. Tyrell, St. Catharines, Ont.; F. E. Burton, Niagara Falls, N. Y.; H. M. White, Castile, N. Y.; Geo. Engle, Springville, N. Y.; L. Wisner, Westfield, N. Y.; Mr. McCoy, Mundie & McCoy, Tonawanda, N. Y.; C. W. Griswold, Hornellsville, N. Y.; J. L. Thayer, Sherman, N. Y.

## "Fletcher Patent System of Trays."

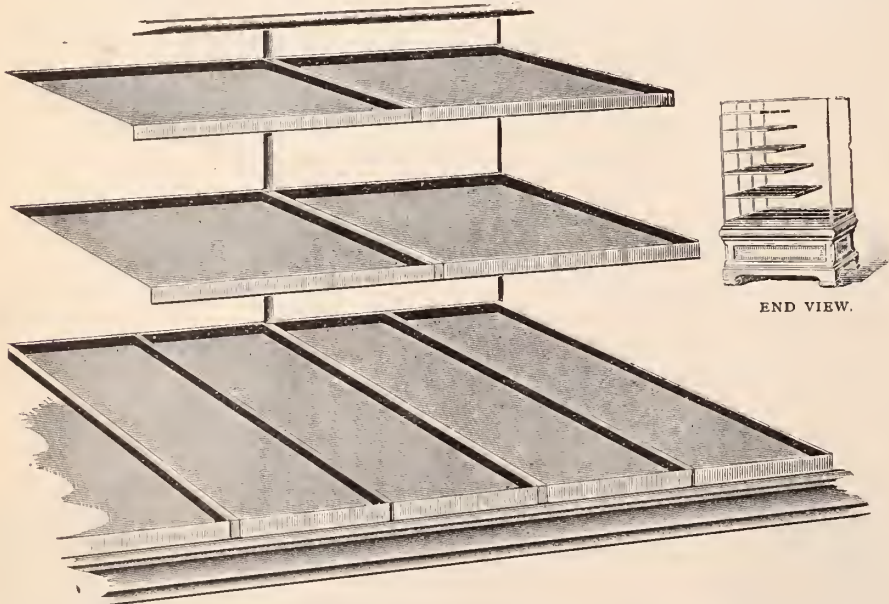

The Trays are invisibly supported and are all removable. The entire floor, also the space between the Trays is clear room to work in. Nothing can be seen nor touched but the Trays.

WILL INCREASE TRAY AREA 75 TO 100%.

### FLETCHER MFG. CO.

NEW CREATIONS THIS SEASON. 259 WEST 27th ST., NEW YORK. SEND FOR CATALOGUE.

# TORTOISE SHELL

## HAIR PINS AND COMBS, WITH STERLING SILVER ORNAMENTS.



No. 1. HAIR PIN.  
\$1.25 Each.



No. 2. HAIR PIN. \$1.50 each.



No. 4. SIDE COMBS. \$7.50 per Dozen Pair.  
VERY NOBBY.



No. 3. HAIR PIN. \$1.50 Each.

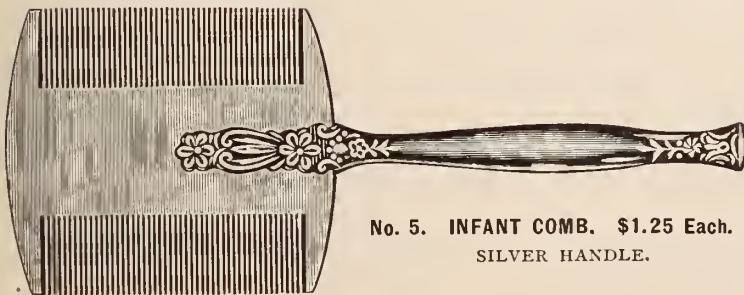

No. 5. INFANT COMB. \$1.25 Each.  
SILVER HANDLE.

All Prices are subject to 6 per cent. for cash.

**EVERY UP-TO-DATE JEWELER**  
Should have an assortment of above Goods.  
**BUY THEM "NOW."**

# GLICKAUF & NEWHOUSE, 84 and 86 State St., Chicago, Ill.

# CLASSIFIED INDEX TO ADVERTISEMENTS.

All Advertisements are entitled to one insertion under proper heading. Extra insertions, \$6.00 per annum  
Extra Headings, \$12.00 per annum.

<b>Art Pottery, Bric-a-brac, Etc.</b>	Page.	<b>Gold and Silver Platers.</b>	Page.	<b>Sample Trunks.</b>	Page.
Bawo & Dotter, 26-32 Barclay St., N. Y. ....	45	Newman, O., 75-77 Nassau St., N. Y. ....	30	Crouch & Fitzgerald, 161 Broadway, N. Y. ....	5
Bing, Ferdinand & Co., 106 Grand St., N. Y. ..	42	<b>Gold Jewelry.</b>		<b>Show Cases.</b>	
Bradley & Hubbard Mfg. Co., Meriden, Conn	14	Carter, Sloan & Co., 15 Maiden Lane, N. Y. ...	27	Smith, B. & W. B., 220 W. 29th St., N. Y. ....	48
Glaenger, Leon J. & Co., 80 & 82 Chambers		Aikin, Lambert & Co., 19 Maiden Lane. . . .	8-44	<b>Silver Plated Ware.</b>	
St., N. Y. ....	3	Cross & Beguelin, 17 Maiden Lane, N. Y. ....	39	Homan & Co., Cincinnati, Ohio. ....	17
Hinrichs & Co., 29 & 31 Park Place, N. Y. ....	47	Griffith, R. L. & Son, 129 Eddy St., Providence, R. I. ....	41	Pairpoint Mfg. Co., New Bedford, Mass. ....	5
Le Boutillier & Co., 860 Broadway, N. Y. ....	36	Hedges, A. J. & Co., 6 Maiden Lane ....	4	Rogers & Bro., 16 Cortlandt St., N. Y. ....	2
Levy, Dreyfus & Co., 9 & 11 Maiden Lane,		Larter, Elcox & Co., 21 and 23 Maiden Lane. .	37	The Wm. Rogers Mfg. Co., Hartford, Conn. . .	5
N. Y. ....	18			Webster, G. A., Chicago, Ill. ....	33
Straus, L. & Sons, 42 to 48 Warren St., N. Y. .	41	<b>Gold and Silver Novelties.</b>		<b>Sterling Silver Novelties.</b>	
<b>Assayers &amp; Refiners.</b>		Riley, John A., & Sloan Co., Ltd., Broadway		Codding Bros. & Heilborn, North Attleboro	
U. S. Smelting & Refining Works, 25 John St.,		and 17th Street. ....	15	Mass. ....	37
N. Y. ....	48	Reddall, John W. & Co., Newark, N. J. ....	20	Hagan, White & Co., 243 W. 23d St., N. Y. . .	9
Guild & Gardner, 189 Eddy St., Providence,		<b>Guards, Scarf Pins.</b>		Richardson, Enos. & Co., 23 Maiden Lane. ....	41
Providence, R. I. ....	15	Security Mfg. Co., 7 Astor House, N. Y. ....	46	Sedwick, C. W., 11 E 20th St., N. Y. ....	12
<b>Auctioneers.</b>		<b>Horological Schools.</b>		<b>Sterling Silverware.</b>	
Boyle, Davis & Goodman, 63 5th Ave., N. Y.,		Parson's School for Watchmakers, Peoria, Ill.		Campbell-Metcalf Silver Co., Providence, R. I.	
611 Pennsylvania Ave., Washington, D. C. . .	16	Philadelphia College of Horology, 623 Heed		Fuchs, Ferd. & Bros., 808-810 Greenwich St.,	
Comrie, A. J., 22 John St., N. Y. . . . .	15	Building, Phila., Pa. ....	24	N. Y. ....	46
H. M. Rich & Co., 21 School St., Boston,		<b>Insurance.</b>		Knowles, J. B. & S. M. Co., Silversmiths'	
Mass. ....	15	Fidelity & Casualty Co., 140-146 Broadway. . .	47	Hall, Union Square, N. Y. ....	14
<b>Badges, Medals, Etc.</b>		<b>Jewelry, Silverware and Optical Cases.</b>		Shiebler, G. W. Co., 179 Broadway, N. Y. ....	15
Stockwell, E. R., 19 John St. N. Y. ....	39	Steinhaus, T. C., 10 Maiden Lane, N. Y. ....	24	Towle Mfg. Co., Newburyport, Mass. ....	47
<b>Carborundum.</b>		<b>Jobbers, Watches, Diamonds, Etc.</b>		Wallace, R. & Sons Mfg. Co., 3 Park Place,	
The Carborundum Co., Monongahela, Pa. ....	8	Allen, Benj. & Co., Chicago, Ills. ....	16-33	Wood & Hughes, 16 John St., N. Y. ....	46
<b>Chronometers.</b>		Aikin-Lambert Jewelry Co., 19 Maiden Lane	8-44	<b>Spectacle and Eyeglass Cases.</b>	
Bliss, John & Co., 129 Front St., N. Y. ....	4	Keller, Ettinger & Fink, 24 John St. ....	26	White, W. B. & Son, Boston, Mass. ....	46
Heinrich, H. H., 14 John St., New York. ....	24	Myers, S. F. & Co., 48 Maiden Lane, N. Y. ....	48	<b>Tissue Paper.</b>	
<b>Clocks, French, English and American.</b>		Oppenheimer Bros. & Veith, 35 Maiden Lane,		Dexter, C. H., & Sons, Windsor Locks, Conn.	44
Jacques, Chas., Clock Co., 22 Cortlandt St.,		N. Y. ....	12	<b>Tortoise Shell Goods.</b>	
N. Y. ....	48	Sproehle, F. M. & Co., Chicago, Ill. ....	35	Glickauf & Newhouse, 84 & 89 State Street,	
Evans, W. F. & Sons, Hensworth, Birming-		West, White & Hartman, 80 5th Ave., Pitts-		Chicago, Ill. ....	29
ham, England. ....	46	burgh, Pa. ....	18	Potter, W. K., Providence, R. I. ....	15
<b>Cut Glass.</b>		<b>Musical Boxes.</b>		<b>Tool Manufacturers and Dealers.</b>	
Clark, T. B. & Co., 860 Broadway, N. Y. ....	46	Cuendet, L. J., 21 John St., N. Y. ....	15	Allen, Benj. & Co., Chicago, Ill. ....	16-33
<b>Diamond &amp; Precious Stone Importers.</b>		Jacot & Son, 39 Union Square, N. Y. ....	15	American Watch Tool Co., Waltham, Mass. . .	40
Cottier, C., & Son, 14 Maiden Lane, New York	48	<b>Oils.</b>		Moseley & Co., Elgin, Ill. ....	33
Disselkoeen, John N., 19 E. 16th St., N. Y. .	27	Kelley, Ezra, New Bedford, Mass. ....	8	Oliver, W. W., Buffalo, N. Y. ....	48
Falkenau, Oppenheimer & Co., 40 Maiden		<b>Ophthalmic College.</b>		<b>Trays.</b>	
Lane, N. Y. ....	48	St. Louis Ophthalmic College, St. Louis, Mo. . .	24	Fletcher Mfg Co., 259 W. 27th St., New York.	28
Hedges, Wm. S. & Co., 170 Broadway, N. Y. . .	26	<b>Optical Goods.</b>		<b>Trunks and Traveling Bags.</b>	
Kahn, L. & M. & Co., 172 Broadway, N. Y. . .	48	Berger, Albert & Co., 47 Maiden Lane, N. Y. .	5	Crouch & Fitzgerald, 161 Broadway, N. Y. ....	5
Kipling, R. A., Hays Bldg., N. Y. ....	26	Geneva Optical Co., Chicago, Ills. ....	33	<b>Watch Manufacturers.</b>	
Randel, Baremore & Billings, 29 Maiden Lane	27	Queen & Co., Philadelphia, Pa. ....	9	A. C. Smith Watch Co., 177 Broadway . . . . .	7
Smith, Alfred H. & Co., 182 Broadway, N. Y. .	26	Spencer Optical Mfg. Co., 15 Maiden Lane, N. Y.	37	Trenton Watch Co., Trenton, N. J. ....	17
Tannenbaum, L., & Co., cor. Maiden Lane and		<b>Pens, Pencils, etc.,</b>		The E. Howard Watch and Clock Co., 41	
Nassau St., N. Y. ....	23	Aikin, Lambert & Co., 19 Maiden Lane, N. Y.	8-44	Maiden Lane. ....	19
<b>Diamond Jewelry.</b>		Diamond Point Pen Co., 7 Astor House' N. Y.	15	<b>Watch Case Manufacturers.</b>	
Waterman & Lehman, 37 Maiden Lane, N. Y.,	26	LeRoy, Fairchild & Co., 3 Maiden Lane. ....	16	Wadsworth Watch Case Co., Newport, Ky. . .	33
<b>Diamond Polishing Mills.</b>		Smith, H. M. & Co., 83 Nassau St. ....	12	<b>Watch Case Repairers.</b>	
Arthur Co., The, 86 John St., New York. ....	48	<b>Photo-Miniature.</b>		The Planchamp & Becker Co., Chicago, Ill. . . .	33
<b>Display-Window.</b>		Favre Leon, 107 East 26th St., N. Y. ....	15	<b>Watch Importers.</b>	
Pearce, Frederick, 77-79 John St., N. Y. ....	38	<b>Ring Makers.</b>		Hyde's, J. E., Sons, 22 Maiden Lane, N. Y. . .	24
<b>Fine Stationery.</b>		Bowden, J. B. & Co., 192 Broadway, N. Y. ....	9	Mathey Bros., Mathez & Co., 21 & 23 Maiden	
Parsons & Greene Co., 18 Murray St., N. Y. . .	5	Bryant, M. B. & Co., 10 Maiden Lane, N. Y. . .	4	Lane, N. Y. ....	14
<b>Furniture.</b>		Hildreth Mfg. Co., 53 Maiden Lane, N. Y. ....	41	Racine, Jules, 180 Broadway, New York. ....	47
Smith, Geo. Wm., 3907 Powelton Ave., Phila.,		Waite, Thresher Co., Providence R. I. ....	25	Robert, Edmond E., 21 Maiden Lane, N. Y. . .	4
Pa. ....	46	Wood, J. R. & Sons, 14 John St., New York. . .	46	<b>Watch Keys.</b>	
<b>Gold and Rolled Plate Jewelry.</b>		<b>Safes.</b>		Clark, A. N., Plainville, Conn. ....	
Foster & Bailey, Providence, R. I. ....	13	Mosler, Bahmann & Co., 518 B'way, N. Y. ....	48		

## Special Notices.

Rates 75c. per insertion for notices not exceeding 3 lines (25 words); additional words 2 cents each. If answers are to be forwarded, postage stamps must be enclosed. Two insertions, 15 per cent. off; three insertions, 20 per cent. off; four insertions or more, 25 per cent. off. Payable strictly in advance. Display cards on this page will be charged at \$2.00 per inch for first insertion, subject to same discount as above for subsequent insertions.

Under the heading of **Situations Wanted** on this page advertisements will be inserted for **One Cent a Word**. This offer refers to **Situations Wanted only**. Payable strictly in advance. If answers are to be forwarded, postage must be enclosed.

## Situations Wanted.

*Notices under this heading ONLY are charged at one cent a word, payable strictly in advance. If answer are to be forwarded, postage must be enclosed.*

BY an American watchmaker, jeweler and salesman with complete set of tools and eight years' experience. Best reference. Address Reliable, Box 202, Station A, Meriden, Conn.

WATCHMAKER would like position; can do fine and complicated watch work; also French clock work if required. Best references as to ability, etc. Address Curtis, care JEWELERS' CIRCULAR.

SITUATION wanted by an A1 watchmaker and engraver: sober and reliable; 16 years' experience; A1 reference; have fine set of tools. P. B. L., P. O. Box 412, Winchester, Ill.

SITUATION wanted by a first-class watchmaker; will act as salesman if desired. Address K., care JEWELERS' CIRCULAR.

FIRST-CLASS watchmaker, jeweler and salesman wants position. Young man; single; 12 years' experience. Best of references. Address C. E. Hagy, Abingdon, Va.

WANTED.—A steady position by a first-class watchmaker. Twenty years' experience. Have my own tools. Best of references. A. L., care of JEWELERS' CIRCULAR.

CAPABLE young man wants position as watchmaker. Can do all kinds of bench work. Best of references. C. R. Keil, South Kaukauna, Wis.

POSITION WANTED by a young man 21 years of age, having three years' experience. Can do ordinary watch and clock repairing; also a first class salesman. Can speak German and English, and has some ability as an engraver. Can give best of reference. Address Louis Becker, 702 N. 24th St., Philadelphia, Pa.

AN experienced salesman in watches and jewelry wants a position to travel for a jobbing or manufacturing house in New England. Address M. B. care Jewelers' Circular.

BY a first-class watchmaker, jeweler and engraver. Can also do clock repairing. Speaks German and can give good reference. A permanent position desired. Address Box 253, Robinson, Ills.

WANTED.—Position by young man, age 22. Can do clock, watch and jewelry repairing. Four years' experience. Best of references. Box 1084, Meriden, Conn.

SITUATION wanted by a young lady in the business department of either watch, jewelry, silver or kindred trades. Several years' experience. First-class references. New York or Newark preferred. Address C. T. M., care of JEWELERS' CIRCULAR.

BY a practical watchmaker, 5 years' experience, to finish learning trade. Best of references. Address P. O. Box 290, Collinwood, O.

YOUNG MAN having been in the silverware and china business for himself for several years, wishes to take a position with some firm in the same line in New York or Newark. E. L. Kent, 114 Chestnut St., East Orange, N. J.

SITUATION wanted by lady stenographer and book-keeper with Chicago house. Experienced in wholesale jewelry. Address X. Y., care JEWELERS' CIRCULAR, Chicago office, 517 Inter-Ocean Building, Chicago, Ills.

PERMANENT situation by first-class jeweler, diamond setter and engraver. Best of references. South preferred. Address A, care JEWELERS' CIRCULAR.

WANTED—A steady position by a first class watchmaker, engraver and jeweler. Best of references. Address T. D. Knapp, 116 S. Howard St., Akron, O.

A YOUNG man having six years' experience in watchmaking and plain engraving, having American lathe and full set of tools, desires steady position. A1 references. Philadelphia, care JEWELERS' CIRCULAR.

## Help Wanted.

WANTED.—A good manufacturing jeweler; one that can do repair work, re-enameling, plating, and set stones. Address A. H. Furstnow & Co., Fond du Lac, Wis.

## Miscellaneous.

I BUY JEWELRY STOCKS—Manufacturers, jobbers and retailers desiring to dispose of surplus or entire stocks of diamonds, watches and jewelry can find quick cash buyer by addressing Stephen S. Harmon, 1240 Lexington Ave., New York City.

## Business Opportunities.

PARTNER WANTED—In an established jewelry business in State of Illinois, located where crops are good and hard times not felt, doing the best business outside of Chicago. Population 12,000. Capital required about \$8,000; annual cash sales \$35,000. Investigation courted. Best of reference given and required. Prefer young man of some experience. Address F. E. B., care JEWELERS' CIRCULAR.

## For Sale.

THREE 10-foot black walnut side show cases at \$50 each; a bargain. H. C. Kachlein, La Fayette, Ind.

PAYING jewelry business in live town established 20 years. No competition. Bench work alone pays \$50 monthly. Clean stock. Ill health reason for selling. Will sell for \$1,500 cash. W. C. Bailey, Winthrop, Me.

FOR SALE.—A rare opportunity for a practical watchmaker or jeweler; one of the oldest established jewelry businesses, on the leading avenue uptown, with a well selected and clean stock of diamonds, watches, jewelry, silverware and optical goods. Will invoice from \$10,000 to \$11,000. Repairing in all branches amounting to about \$3,000 yearly. Will reduce stock if desired. Good reference given. Address P. O. Box A. R. 443, New York City.

## FOR SALE.

The entire Plant of H. Muhr's Sons' Factory; one of the most complete in this country will be sold for reasonable price Bids solicited.

BROAD AND RACE STS.,  
PHILADELPHIA.

## 17 Jewel Dueber-Hampden Watches

ARE THE MOST RELIABLE WATCHES MADE.  
A FULL LINE OF DUEBER CASES AND HAMPDEN MOVEMENT.

Write for New Price List.

**Brethauer Watch and Jewelry Co.,** Special Agents,  
71 WASHINGTON ST., CHICAGO, ILLS.

## ... WALL CASE ...

32 ft. long, cherry finish, doors slide up. Plate glass mirror in center, 36x66. Base with cupboard and drawers.

APPLY TO

E. P. WHEELER, 204 Market St., Paterson, N. J.

## A RARE OPPORTUNITY

To Buy at a bargain Fixtures and Lease of a 16 years established Jewelry Store on the leading avenue up town in New York City.

Owner is compelled, on account of failing health, to close out the Stock of Diamonds, Watches, Jewelry and Silverware before January 1st.

Sales have averaged the last five years from \$16,000 to \$20,000, and the amount of repairing from \$3,000 to \$4,000 yearly.

Good reference given.

Address J. T. G., care Jewelers' Circular.

THE OLDEST,  
Newsiest,  
Most Thorough,  
Most Liberal,  
Best Illustrated,  
Handsomest,  
THE PAPER.

Features.

WORKSHOP NOTES. PARIS FASHIONS. FASHIONS IN JEWELRY. THE CONNOISSEUR. PRACTICAL LESSONS FOR OPTICIANS. TECHNICAL ARTICLES. LATEST PATENTS. SUGGESTIONS FOR WINDOW DECORATIONS.

IT PAYS

TO KEEP IN TOUCH WITH  
TRADE AFFAIRS.

DO SO

... BY ...

SUBSCRIBING TO

The Jewelers' Circular.

OF TRADE WESTWARD TAKES ITS WAY

# WESTERN SUPPLEMENT of THE JEWELERS' CIRCULAR

Chicago Office: Room 517, Inter-Ocean Building.

VOL. XXIX.

CHICAGO, WEDNESDAY, NOV. 7, 1894.

No. 15.

## Chicago Notes.

### TRADE CONDITIONS.

The jobbing trade last week was lighter in nearly all lines than in the previous week. The elections had a depressing influence on trade in drawing the attention away from business channels and the end of the month also tended to delay sales. As a rule orders from travelers were less in number, the country having gone politics-mad. Now that the excitement has passed a hopeful feeling is setting in and all predict a healthy volume of business from now on to the end of the year. Travelers are taking good orders in sterling silverware and the factories are reported to be behind the orders. Plated ware is holding its own with 1893. In this line the month of October shows a nice increase. There is a scarcity of staples. Dealers are confident of satisfactory business throughout the year.

While Chicago suffered from trade lethargy the past week, all reports to this center show that manufacturers are having all they can do to keep abreast of orders. Clock houses are doing a good business.

The silverware department of Otto Young & Co. is working three nights a week with additional number of helpers.

G. C. Creyk has given a bill of sale to J. J. Smith for \$2,000.

John Van Ess, who robbed F. M. Sproechnle & Co., has been sentenced to the reform school.

C. P. Jacobs, Chicago manager for Roman & Co., left Wednesday for a business trip east via Cincinnati.

Frank Schneider, son of H. F. C. Schneider, Dubuque, Ia., is taking a course of engraving with J. B. Wiggins, 44 Madison St.

C. P. Dungan, for the Meriden Britannia Co., returned from his western trip and left Sunday for new routes in the same territory.

Dewitt Bros., 43d St. and Calumet Ave., has confessed judgment to J. C. Christman,

Jr., for \$1,594. Christman sold the place to Dewitt Bros. about the 1st of last February.

James K. Wiggins, son of J. B. Wiggins, the well-known engraver, has returned from Matagalpa, Nicaragua, where he is engaged in coffee planting.

Seth E. Thomas, treasurer of the Seth Thomas Clock Co., visited the Chicago office of the company Wednesday, on his return from San Francisco.

With each recurring November and April Mr. Glickauf, of Glickauf & Newhouse resumes his duty as a judge of election. Mr. Glickauf yesterday presided over the 6th precinct of the 24th ward.

Manager Loeb, of the Chicago office, returned the fore part of last week from a western trip for the Wadsworth Watch Case Co. The vermicelli star is being made in 12 size case and is making a decided hit.

The R. Chester Frost & Co., of Chicago, have incorporated with a capital stock of \$50,000 in single shares of \$100 to manufacture, buy and sell watches, clocks, silver and plated ware and jewelry of all and every description. The promoters are R. Chester Frost, Geo. K. Harrington and Reuben W. Cohen.

The Chicago Engravers' Association will meet Nov. 7 for the adoption of by-laws and to discuss a scale of prices which it is claimed will be a benefit to the retailer, jobber and engraver alike. The association comprises the leading jewelry engravers of the city and its work should result in benefit to the trade.

Mr. Bardel, of Heller & Bardel, diamond mountings, New York, spent a few days with the Chicago trade. Frank Gibson, for William Kincherf, also showed here his line of mountings and white stone goods. G. W. Bleecker, of Bassett Jewelry Co., displayed a fine line of gold and silver novelties and met with success.

E. G. Webster & Son have just issued a supplement of their new goods which is a very creditable production. The book is filled with patterns never before presented

to the trade, which comprise a most excellent selection. The supplement can be had by addressing the home office, Brooklyn, N. Y., or the Western office, 44 Madison St., Chicago.

Rivell & Co. exhibit on their second floor the celebrated Columbian clock, manufactured by the Goldsmiths & Silversmiths Co., London, England. The clock was a center of attraction in the English section of Manufactures' building, at the World's Fair. It stands 15 feet high, and has moving figures and chimes. It was fully described in THE CIRCULAR'S World's Fair Supplement.

Had other States equaled in proportion the percentage of buyers in town from Iowa, the standard of increase would have been well kept up. Full Fall stocks were sold to quite a number of the following out-of-town jewelers, who made personal selection here last week: Mr. Baker, Fayette, Ia.; John L. Strow, Ft. Dodge, Ia.; J. J. Heath, Lansing, Mich.; Mr. Giddings, Clark & Giddings, Sterling, Ill.; F. E. Shortess, Traer, Ia.; A. R. Knights, Dubuque, Ia.; J. W. Neashan, Ottumwa, Ia.; D. E. Holland, Lapeer, Mich.; H. L. Chapin, Denver, Col., representative of Mrs. M. E. Briggs, Howell, Mich.; Charles E. Axt, Odell, Ill.; W. H. H. Horine, Carlinsville, Ill.; J. Jacobs, Winterset, Ia.; C. C. Kennedy, Hinckley, Ill.; L. Luchtemeyer, Blue Island, Ill.; E. C. Long, Shabbona, Ill.; Otto Wettstein, Rochelle, Ill.; C. J. Peterson, St. Charles, Ill.; F. S. Phillips, Ogden, Mich.; C. R. Stoops, Napanee, Ind.; G. R. Schafer, Morton, Ill.; Secord-Hopkins Co., Kensington, Ill.; J. W. Burkitt, Arlington Heights, Ill.; P. W. Clark, Rensselaer, Ind.; J. L. Davery, Elgin, Ill.; Eggerman & Son, Aurora, Ill.; W. D. Emerson, Aledo, Ill.; C. W. Gearhart, Oregon, Ill.; D. E. Herrington, Hebron, Ill.; J. F. Ingalls & Son, Waukegan, Ill.; P. Jagla, Kiel, Wis.; E. J. Johnson, Sandwich, Ill.; W. P. Zennan, Waukegan, Ill.; W. H. Murphy, Fox Lake, Wis.; W. H. Evans, Red Oak, Ia.; M. V. Cole, Michigan City, Ind.; C. C. Chase, Elroy, Wis.; Harry P. Holmes, Des Moines, Ia.; J. C. Van Slyke, Avoca, Ia.; Mr. Hunter, Bloomington, Ill.



# LOOK AT THESE PRICES!

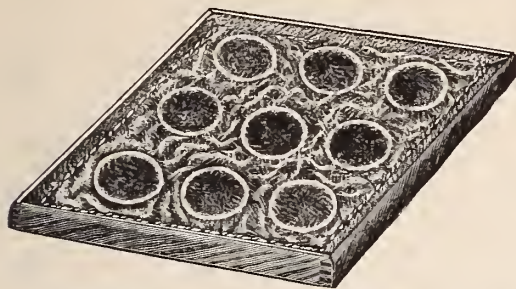

Show Case Trays with Solid Walnut Frames lined with Fine Red Silk Plush, with Old Gold Border, and made to stack one on top of the other. Size, 11¼ x 11¼.

For Gents' Watches, each . . . . . \$1.25  
 For Ladies' Watches, each, . . . . . \$1.25  
 For Rings, each . \$1.25. For Chains, each, . \$1.25  
 For Charms, ea., \$1.25, for Card Jewelry, plain, ea., 80c.

Subject to the usual discount for cash.

## CHRISTMAS IS COMING.

Make your Stock Attractive and Fresh. It does not cost much and will add largely to your SALES.

## BENJ. ALLEN & Co.,

141 & 143 State St.,  
 CHICAGO, ILL.

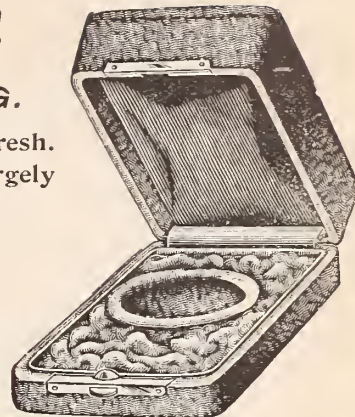

FINE PLUSH BOXES.

WATCHES, CLOCKS,  
 DIAMONDS,  
 SILVERWARE  
 and JEWELRY.

For Gents' Watches, per dozen, \$3.00  
 For Rings, per dozen . . . . . \$2.00  
 For Six Tea Spoons, per dozen, \$9.00  
 For Child's Set, per dozen . . . . \$9.00  
 For Sugar Shell, per dozen . . \$9.00  
 For Ladies' Watches, per dozen, \$2.00  
 For Ear Drops, per dozen . . . \$3.50  
 For S x Table Spoons, per dozen, \$15.00  
 For S x Coffee Spoons, per doz., \$15.00  
 For Butter Knife, per dozen . . \$9.00

Subject to the usual discount for cash.

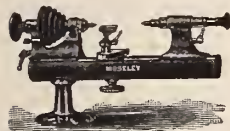

One of the best of the very best.

QUALITY IS THE STANDARD OF VALUE FOR WHICH WE COMPETE "THE MOSELEY."

"A Bread Winner" for the watchmaker We furnish you good lathes and chucks, while the other fellow furnishes the wind.

MOSELEY & CO., Elgin, Ill.



No. 2 Moseley Wire Chuck has length, strength, accuracy.

### THE PLANCHAMP & BECKER CO.

Makers and Repairers of

### WATCH CASES,

Gold and Silver Plating

— of Watch Cases a Specialty.

UNEXCELLED FACILITIES.

63 and 65 East Washington St., Chicago.

PARSONS : SCHOOL

— FOR —

WATCHMAKERS,

PEORIA, . . . . . ILL.

Send for Circular and Terms.

PARSONS & CO.

### G.A. WEBSTER

42 & 44 Madison St., Chicago, Ill.

Manufacturer,

AND WESTERN AGENT FOR

E. G. WEBSTER & SON, of Brooklyn, N. Y.

A. F. TOWLE & SON CO., of Greenfield, Mass.

No jeweler or watch repairer should be without a copy of "WORKSHOP NOTES," a new and very useful book for the workshop. Send for circular containing a complete index of the book, and judge of its merits for yourself.



## GENEVA OPTICAL CO., CHICAGO.

CATALOGUES.

- PART 1—General Catalogue of Optical Goods.
- " 2—Microscopes and Accessories.
- " 3—Photographic Cameras, Sticks and Supplies.
- " 4—Thermometers, Barometers and Meteorological Instruments.

**PRESCRIPTION WORK**  
**OCULISTS' or OPTICIANS' OUTFITS.**

Made with Promptness and Accuracy.

Trial Cases.  
 Ophthalmoscopes.  
 Lens Measures.

CORRESPONDENCE SOLICITED.

# THE WADSWORTH WATCH CASE CO.



774.

General Offices,  
 NEWPORT, KY.

Filled



793.

NEW 12 SIZE  
 TO FIT ALL 6S. P. S. MOVEMENTS.

Cases.



802.

Chicago Office,  
 COLUMBUS BUILDING.

### Cincinnati.

Jos. Noterman & Co. report order work very brisk, but trade is somewhat quiet.

C. Hellebush secured the Phoenix Club order for silver pieces. They are displayed in his large show window.

Ed. Hirsh, of Bene, Lindenberg & Co., will be married this month. The boys will remember him very handsomely.

D. Schroder & Co. are having a good trade. A. Herman started out, Monday, with a new line of rings, etc. Isa Schroder is on his way south. Eugene Frohmyer is west.

Frank Carey, jeweler, Lebanon, O., made an assignment last week; liabilities \$2,000, with \$1,500 assets. The failure the day before of his father, a dealer in notions and fancy goods, was the cause.

The Wadsworth Watch Case Co. are having a decided boom. They are working nights, and are behind with their orders. These facts go to prove that the Wadsworth case is growing in popularity daily.

C. H. Williams, of the Mossberg Wrench Co., manufacturer of novelties, Attleboro, Mass., was in Cincinnati last week and made Oskamp, Nolting & Co. sole agents in this section for their novelty, a silver knife sharpener for table use.

Gustave Fox & Co. had their opening, Nov. 1st, of their new store, which is located at 80 E. 4th St. They have a charming place, with oak fixtures and all the equipments of a modern diamond and fine jewelry establishment. They received two beautiful floral offerings, representing a marquise ring and a horse shoe. The weather was glorious and their opening was certainly smiled upon by Providence.

### Detroit.

Edward F. Roehm has returned from a four weeks' trip to eastern points.

Ernest Pudrith, representing Eugene Deimel, returned last week from a month's trip through the State.

W. E. Walton, representing John Segsworth & Co., Toronto, spent last week in the city visiting friends.

Eugene Deimel put in a very complete line of hollow ware in the back part of his wholesale establishment, last week.

W. D. Le Roy, for many years a jeweler in Coldwater, Mich., has removed his stock to Rockford, Ill., where he will start a new store.

Oscar B. Marx, with the United States Optical Co., was the candidate for Alderman from the 15th ward on the Republican ticket.

Wright, Kay & Co.'s store is being fitted with new patent space saving fixtures by the Fletcher Mfg. Co., 259 W. 27th Street, New York.

C. R. Smith, Albion, Mich., has sold out his interest in his grocery business

there and will shortly start a jewelry store in Huntington, Ind.

Charles D. Robinson, for the last 30 years a jeweler, has located in Cassnovia, Mich. He will do a repairing business at first and intends to put in a stock later.

Jacob F. Teichner, with F. G. Smith & Sons, last week received a telegram from Milan, Italy, announcing the death of his brother, Samuel Teichner. He was well known to the traveling fraternity of this country.

The demand for high priced watch movements continues strong. A large number were sold here last week by the leading retailers, and jobbers shipped many to interior cities. All the employes of the Michigan Central Railroad are required by the company to have timepieces of a certain standard.

The attention which has been bestowed upon election in this vicinity has materially affected business during the last two weeks. Mail orders were lighter and country dealers were more conservative in buying. Among those last week in the city from Michigan were: Mr. Henrich, Henrich & Anchor, Cass City; A. W. Kludt, Lennox; C. E. Montford, Utica; William Till, Columbiaville; W. K. Ambler, Northville.

### The Brethauer Watch & Jewelry Co. Daringly Robbed.

CHICAGO, Ill., Nov. 2.—A daring daylight robbery of a wholesale jewelry house is an innovation these days that shows the extremities of danger to jewelers from desperate classes of criminals. Yet this is what happened to the Brethauer Watch & Jewelry Co. at 2.20 o'clock P. M. Tuesday. G. W. Brethauer, Jr., the secretary of the company, was inditing a letter at that time at the office of the firm, second floor, 71 Washington St., when two decently dressed men, under middle age, one tall and lean and with dark mustache and the other short and stout, entered and asked the value of a ring he had. The valuation was given and the man offered the ring for sale.

Mr. Brethauer stepped to the jewelry safe for the money, and turned to find himself covered with a revolver held by the smaller man, while the stouter grappled him by the throat and thrust him into the vault, locking both doors. With an open field before them the robbers hastily gathered up watch cases, rings, and the better grades of jewelry and disappeared.

C. S. Shepherd, agent for Martin, Copeland & Co. and the Roy Watch Case Co., called at the office within ten minutes of the time of the robbery. He said to THE CIRCULAR correspondent, in speaking of the affair:

"As I stepped into the place I was surprised to find no one in the room and the stock in confusion. Several trays were on the show cases, a gold ring lay on the floor, and a sample roll of silver ware was on the floor near the vault door. The vault was

closed. Soon I heard what seemed to be at first thought some one putting up a stovepipe in an adjoining room or other part of the building, but on repetition it seemed to come from the vault. I swung open the outer vault door and found there was some one in the vault kicking on the door. I called out and young Brethauer answered. After some difficulty I raised the bar fastening the inner door and released him. He was pale and trembling and labored under great excitement, at times hysterical. I worked with him some time to quiet him and at the earliest opportunity rushed across the corner to the city hall and notified the detective bureau. I am thankful that I stood on the street below talking with Mr. Stern for several minutes, before entering the place, otherwise the robbers would have been under the necessity of 'taking care' of me, and that lead pipe they left behind was a dangerous weapon to run against."

A few minutes later G. W. Brethauer, the father, returned from a visit to a son employed in Marshall Field's, and was made acquainted with the facts. At the time the excitement was too great for a rational interview. The following day Mr. Brethauer estimated his loss at between \$2,500 and \$3,000. The inventory had not yet been taken, but it was known that 200 watches, some of them high grade movements and diamond ornamented cases; fully 200 rings, averaging about \$5 each in value; a lot of gold pens and lockets, all the 6 size movements, a full drawer and several partly filled drawers of chains, and the cash drawer in the safe, were taken. In the latter there was little money, but the thieves overlooked \$40 in gold, \$15 in bills, and some valuable papers in the desk drawer.

"I was going to put this money in the safe for safety as soon as I had finished my letter," said Mr. Brethauer, Jr. "I think the loss will have no effect on the business, other than temporary," said G. W. Brethauer. "It is too bad, for I was in as good shape as a man could be. Outside of a watch company I had but two accounts of any amount, one for \$160 and one for \$43.37, both to Providence manufacturers, and a few local accounts—perhaps \$300 in all, not to exceed that. The day previous I checked out \$601.22," and the check book stub was shown in verification.

Quite a large item of the loss was a shipment of 111 watch cases billed to the company on the 25th of October. The only clew left by the robbers so far discovered is the piece of lead pipe found on the floor near the vault, and the detectives have little to work on. The insinuations of one of the local papers that there was a touch of suspicion about the case are positively baseless and without other foundation than a sensation loving reporter's brain.

Rob Herre has purchased the jewelry stock of Dr. Atkinson, Dodge, Neb., and will engage in business there about the first of November.

**San Francisco.**

A boy has arrived in the family of Morris Van Vliet, the Market St. jeweler.

Trade has been spasmodic of late, with good and bad days, but it has averaged fair.

Chas. Weinsbank, of Armer & Weinsbank, has returned from his northern trip.

G. E. Wilkins, Red Bluff, and C. J. Noack, Sacramento, bought goods in San Francisco recently.

H. Hotfilter, Sacramento, and B. F. Winckler, Healdsburg, were recently in town on business.

H. C. Rowbotham, of Philadelphia, Pa., is in town closing out the jewelry department of H. Muhr's Sons.

Max Shirpser, formerly of the Max Shirpser Jewelry Co., has removed from 910 to 940 Market St., where he is now holding daily auction sales.

Among the latest arrivals of eastern travelers were: A. Limbach, Foster & Bailey; Mr. Williams, Ostby & Barton Co.; and Geo. Paine, E. I. Franklin & Co.

Harry Nordman, who is traveling south for the Standard Optical Co., found trade more than fair. This new firm are doing so well that they started last week another traveler north.

Mr. Huteson, of the Spencer Optical Mfg. Co., New York, has been in town. His brother, Thos. Huteson, who is traveling for Julius King Optical Co., Cleveland, O., is now doing southern California.

H. F. Wichman has returned to Honolulu. He has purchased a large stock of Christmas goods here and in the east. His trip was prolonged for the sake of the health of his wife and little boy, who accompanied him this year.

H. C. Ahlers last week paid his first dividend to his creditors. It amounted to 33.70 per cent. While some of the creditors who are managing this part of his business anticipate an ultimate return of 60 per cent., others believe it cannot possibly exceed 50.

**Pacific Coast Notes.**

W. T. Wright, Pocatello, Idaho, has discontinued his jewelry business.

Chas. Niner will occupy one of the rooms in W. L. Adams' new brick block, Santa Maria, Cal.

J. S. Baker, watchmaker, Riverside, Cal., will hereafter carry a line of watches, clocks and jewelry.

A closing out auction sale is proceeding at the New York Jewelry Store, 323 Morrison St., Portland, Ore.

F. R. Stearns, Petaluma, Cal., is enlarging the floor space of his jewelry store, and otherwise refitting his place of business.

Henry Buschne, jeweler, who has recently returned to Mayfield, Cal., from Honolulu, is erecting a new building to be used as a jewelry store.

The City Council of San Diego, Cal., has adopted an ordinance, in accordance with a petition presented by local jewelers, to impose a license of \$15 on auctioneers of jewelry.

**Tacoma, Wash.**

Louis Luchardt, a jeweler of Spokane, will open a store in North Yakima, Wash.

Tacoma jewelers report a good trade during the Inter-State Fair, which closed last week.

F. Maucke, of this city, recently sold a coffee and tea service which was presented to Director-General Bucey, of the Inter-State Fair.

Receiver Griffin has removed the Simon Rumpf stock to larger quarters at 900 Front St., Seattle, where it will be disposed of.

Joseph Mayer, wholesale jeweler, Seattle, has removed from the New York block to the Occidental block, and is now issuing a 600 page catalogue.

A man giving his name as "John Doe" was found guilty in Castle Rock last week of burglarizing the jewelry store in that town and was sentenced to three years in the penitentiary.

Some time since jeweler Joseph Schade, Portland, sold a costly calendar clock to a church in the country. A couple of weeks ago one of the trustees of the church called on him and stated that the calendar part of the timepiece was out of order and asked him to put it to rights. Mr. Schade, a couple of days later, was about to go when a farm wagon drove up in front of his place and a man came in with a bundle wrapped in a cloak, which, when unfolded, disclosed the church clock. The man said he was from Pendleton and wished to sell the timepiece. Schade remarked that it looked very much like the one he had sold the church people. The stranger grew indignant and told the jeweler to go out and see his wife, who would prove that it had not been stolen. Schade followed the man, and just as they reached the wagon the stranger jumped in and drove off hurriedly. Schade repaired the clock and turned it over to the trustees.

E. L. Jones, Sandusky, O., sends THE CIRCULAR the following list of names of students who took a course in optics at the Julius King Optical Co.'s establishment, Cleveland, O., in September: Murace Smith, Massillon, O.; A. T. Brady, Sharon, Pa.; A. Seidensticker, Hamilton, O.; G. G. Borlin, Middletown, O.; L. W. Blossom, Akron, O.; H. A. Tunehorst, Jerseyville, Ill.; C. D. Horton, Port Huron, Mich.; Geo. H. Dickinson, Geneva, O.; A. E. Axman, Franklin, O.; Earl F. Collins, Newark, O.; Fred. B. Rebman, Danville, Pa.; Frank B. Moore, Cleveland, O.; Ed. L. Jones, Sandusky, O.

**B**UILT FOR BUSINESS

YES, THAT'S WHAT THESE PRICES ARE MADE FOR.

**ELGINS REDUCED.**

THE FOLLOWING GRADES WILL BE CLOSED OUT AT PRICES QUOTED WHILE THEY LAST.



H. H. TAYLOR.

Compensation Balance, Breguet Hair-spring, adjusted, 15 Jewels (4 pairs setting), Patent Regulator, Hunting or Open Face.

- Gilded Movement, - - - - \$15.00
- Nickel Movement, - - - - 18.00
- No. 80. Gilt, Hunting, - - 15.00
- No. 76. Gilt, Open Face, - 15.00
- No. 33. Nickel, Hunting, - 18.00

**New 17-Jewel Elgin**

18-Size Movement.

B. W. RAYMOND.

Compensation Balance, Breguet Hair-spring, adjusted, D. S. Dial, 17 Jewels (4 pairs settings), Patent Regulator, Hunting or Open Face.

- Gilded Movement, - - - - \$28.00
- Nickel Movement, - - - - 32.00
- No. 70. Gilt, Hunting, - - 28.00
- No. 77. Gilt, Open Face, - 28.00
- No. 27. Nickel, Hunting, - 32.00
- No. 116. Nickel, Open Face, 32.00

Prices Subject to Catalogue Discounts.

**F. M. SPROEHNLE & Co.,**

CHICAGO.

PUBLISHERS OF **our Salesman**

SEND AND GET OUR CATALOGUE. IT WILL PAY YOUR RENT.

### Connecticut.

The Thomaston watch factory is running overtime every day at present.

The case department of the Winsted Optical Co., New Winsted, is overrun with orders.

Alderman William H. Watrous, of Hartford, has purchased the steam yacht *Judy*, built by Herreschoff, at Bristol, R. I.

C. H. Tibbits, of Simpson, Hall, Miller Co., was presiding officer at Wallingford's biggest Democratic rally of the campaign, Nov. 2d.

C. C. Carroll, the Wallingford jeweler, is preparing to remove to his new and handsome store in the fine new Judd block, just completed.

The employes of the Waterbury Watch Co. have organized a social club and have christened it the "Elfin Social Club," after the latest model of the company's make.

The Wm. L. Gilbert Clock Co., Winsted, are busy just now in getting out a large shipment of goods for China. The Gilbert and Winsted clock factories are both running 13 hours per day.

St. Paul's Parish Wallingford, has voted to accept the gift of \$2,000 given by the late Samuel Simpson to the church as a testimonial to his deceased daughter, M. De Etta Simpson, for the benefit of the Sunday School.

Mrs. Rogers, wife of W. F. Rogers, of C. Rogers & Bros., Meriden, was honored Tuesday last by being chosen its treasurer by the Connecticut Woman's Suffrage Association and Society for the Study of Political Science, at its annual session in Willimantic.

Frederick L. Tibbals, secretary of the Geo. H. Ford Co., by whose resolute stand the votes at Milford's town election were recounted, the result showing that the Republicans had carried the town and for the first time in many years, was enthusiastically nominated for representative to the Legislature, by the Milford Republicans.

The case of David Ullman, who was arrested last week in New Haven for peddling without a license, is likely to develop some interesting features. Ullman is the agent of the Metropolis Mfg. Co., of New York, and was selling goods when arrested. He was released and his case was continued. His attorney said that he would probably surrender his client, enter a demurrer and take the case to the Supreme Court to test the validity of the statute enacted at the last session of the Legislature against itinerant peddlers.

John R. Cottrill, Plattsburgh, N. Y., has removed to Burlington, Vt., and has fitted up one of the finest stores in the State.

### Trade Gossip.

O. E. Bell Co., Cincinnati, O., have 100,000 new circulars about ready to send out.

Albert Bros., Cincinnati, O., have issued a clock catalogue for the trade. They have also entered this season's campaign with an entirely new line of silver novelties.

Homan & Co., Cincinnati, O., are receiving orders from every direction. Their new novelties are in great demand. Jos. Homan has returned from a trip northwest on an inspection tour.

E. & J. Swigart, Cincinnati, O., are very busy filling orders. They have a real boom in trays and boxes. The dealers have realized that even old goods are brightened up when in new trays and that this house have an unusually assortment and therefore prices that are satisfactory.

All goods in the stock of Le Boutillier & Co., importers of art pottery and bric-à-brac, 860 Broadway, New York, are marked down to accord with the reductions in the new tariff. The stock contains the highest exponents of the potter's art as exemplified in the productions of the English and French establishments.

The last three circulars Nos. (802, 803 and 804), issued by Lapp & Flershem, Chicago, Ill., contain illustrations of timely novelties currently popular. In the clocks, watches and sterling silver, here described. Jewelers will find much to interest them, Lapp & Flershem announce that their 1895 catalogues will shortly be sent to their customers.

The new catalogues, the 15th of the Holmes & Edwards Silver Co. and the 30th catalogue of the Manhattan Silver Plate Co., are now being sent out rapidly. The Manhattan is a finely printed work of 144 pages bound in flexible leatherette covers and displays a full line of the company's wares. The Holmes & Edwards is a handy condensed edition showing half-size cuts of the flatware manufactured by the company including full size teas, and is fully illustrated. The Delsarte and Rialto, leading patterns of the company, are given the place of honor. It is a *multum in parvo* and a popular reference work.

After months of preparation, R., L. & M. Friedlander, 30 Maiden Lane, New York, have just issued an illustrated catalogue of watches exclusively which is replete with new and stylish goods, and has prices corrected up to Nov. 1, 1894. A great many of the designs here shown have been made exclusively for this firm. Those desiring this book can receive it by writing the firm, enclosing their business card or references. This firm also issue a very large book known as "Monarch Catalogue No. 50," which contains the latest illustrations of their watches, diamonds and jewelry. No jeweler should be without it.

# NOVELTIES

IN

ROYAL WORCESTER,  
COALPORT, MINTON,  
POINTON, DOULTON,  
CROWN DERBY, Etc.

FRENCH FANCY GOODS, REAL <sup>AND</sup> IMITATION BRONZES,  
CLOCKS, PEDESTALS, ETC., ETC.

GILT REGULATORS

With Plain, Pierced, Pearl and Rhine Stone Dials.

THE CHOICEST LINE IN THE COUNTRY.

## LE BOUTILLIER & CO.,

860 BROADWAY,

Northeast Corner of 17th Street,

NEW YORK.

**Fashions in Fall Jewelry and Silver Novelties.**

A LADY'S RAMBLES AMONG THE JEWELERS.

It is as difficult to follow the manifestations of the collar slide and the wreath brooch this season, as the chase of the bow-knot and the sword the two preceding seasons. The collar slide takes the following form: The curved oblong, the buckle, the wreath, the double slide, a center slide, rectilinear, oblong or oval wreath, with two smaller flanking ornaments to correspond. These range grave to gay, from lively to severe. They are of gold or enriched with carving, enamel and precious stones. The craze is on the increase and will probably rage with unabated fervor until the holidays.

The jewelers have turned milliners. Neither Francois nor Louise can turn out more artistic bows, rosettes, cockscombs and knots as the framing of the velvet or satin collar demands. In the proudest shop in town a man 6 feet high was holding a leaf green velvet collar daintily and saying to a perfumed dame:

"If you prefer I can make you two rosettes instead." The lady was balancing in her mind as in her fingers the green velvet with a diamond wreath in the center and two flyaway bows at the side held by smaller wreaths against a pale crushed pink velvet collar held down at intervals by diamond bars.

The wreath brooches grow lovelier and more costly. Two were seen with rubies and emeralds as tiny flowers with diamond leaves. Another was a wreath of emeralds and diamonds tied with a bow-knot of diamonds. Other wreaths are made of enameled flowers connected with rosettes. A daisy wreath was seen with an enameled pansy in the middle.

The approach of the social season brings out the costlier pieces of jewelry. Tiaras are evidently to be worn by the prosperous.

One seen was a slender band holding at an upright angle a diamond arrow. Others of gold were shaped like a duchess' crown. A magnificent ornament had a network sown with pale amethysts and a framework of diamonds held up large fire opals. Another of diamonds held bunches of wisteria of amethyst quartz.

Bows of pale satin ribbons have fine feathery aigrettes held by light diamond ornaments. These are for the hair.

Diamond bracelets are seen in their best state as lacework with a pearl or some other gem as the principal form.

The prettiest necklace observed was made of numerous strands of fine gold chain held together by diamond bars.

Certainly a novelty was a chatelaine pin made of mercury wings of seed pearls imbedded in gold, and instead of the usual cherub's head, a comical face in enamel under a silk hat.

ELSIE BEE.



No. 3109. \$7.50 PER DOZ.

**COLLAR BUCKLE BROOCHES.**

VERY STYLISH.

20 PATTERNS.

These Buckles can be attached to any collar as easily as a brooch and will be extensively worn this Fall and Winter. Made in Sterling Silver by

**CODDING BROS. & HEILBORN,**

NORTH ATTLEBORO, MASS.

New York office, C. A. Vanderbilt, 178 Broadway,  
Chicago office, F. A. Buck, 103 State St.

**Larler, Elcox & Co.**  
Manufacturers of Fine Gold Jewelry  
21 & 23 Maiden Lane, New York.



The Attention of the Trade is called to Our Line of . . .

**GENTLEMEN'S RINGS AND SEALS,**

with Intaglios, in **Jade, Jasper and Carnelian.** These goods are exceedingly desirable for this season's trade.

ALSO our full line of Misses' and Children's Rings finished in **Roman.**

See also our large line of **Low Priced Link Buttons,** in Solid Gold.

**Our Spring Back Studs,** improved in construction, are now as near perfect as can be, and never so complete in variety of patterns.



BUY ONLY THE L. E. & CO. STUD. SELECTION OF STUDS SENT ON APPLICATION.



Just Received Our Fall Importation.

**ONE OF THE 400, AND VERY SWELL INDEED.**

**THE PERFECT FIT OF OUR No. 918 GOLD EYE GLASS, SWELL END EYE WIRE.**

Our Ambition to Make a **FAULTLESS GOLD SPEC.** and Eye Glass has been realized, and is appreciated. Strength and Beauty Joined Together **WITHOUT SOLDER.** You "see that hump" no longer. It's gone, and in its place, at ends and bridge, you find that **GRACEFUL SWELL,** as shown in cut. *This is the Modern and Perfect Frame the public are asking for, made in all weights, sizes, shapes and qualities.*

WE MAKE ALL KINDS OF OPTICAL SPECIALTIES, AND TEACH HOW TO GET BEST RETURNS IN HANDLING THEM.

THE **AUDEMAYR OPERA GLASSES,**  
**SPENCER OPTICAL MFG. CO.,**  
15 MAIDEN LANE, NEW YORK.

CALL OR WRITE. IT WILL DO YOU GOOD!

The Best Made for the Least Money. Also Cheaper Grades. The Greatest Variety of Styles. Great Reductions to Correspond with New Tariff and Other Causes.



## MATTERS IN JEWELRY STOREKEEPING.

That this department shall prove mutually beneficial to our readers, it is desirable that the members of the trade generally communicate with THE CIRCULAR regarding any advantageous device or plan that they are utilizing in the conduction of their business.

### Harmony in Store Decoration.

THE table exposed herewith should be kept by jewelers for reference. It is axiomatic to say that harmony should prevail in the decoration of a jewelry store as

### This Ad. Was Effective.

ONE of our local jewelers recently had an advertisement inserted in the *Herald*, the cut of which showed a masked burglar with a club in one hand and a lantern in the

small amount of booty. The ad., it appears, was suggestive and timely, if nothing else, and also proves the value of the *Herald* as an advertising medium.—Norristown, Pa. *Herald*.

### Improvement in Wall Cases.

THE engraving herewith illustrates a new wall case which will prove of especial interest to jewelers.

The three upper rows show the Fletcher patent invisible supported shelving. The supporting power is neither visible nor tangible, and the shelving being adjustable, it forms from all standpoints

TABLE OF COLOR HARMONY WITH PAINTED WOODWORK.

WOODWORK.	WALLS.	FRIEZE.	CORNICE.	CEILING.	CARPET.	UPHOLSTERY.	DRAPERY.
Bluish green gray.	Medium robin's egg blue.	Deep robin's egg blue.	Bluish green grays and silver.	Light bluish green gray.	Bluish green grays, greenish blues.	Citron yellow or kept in tone.	As upholstery.
Cream.	Cream or light salmon.	Salmon pink.	Cream, salmon chamois and gold.	Cream and pale gold, white.	Cream.	Salmon, pink, chamois, gold.	As upholstery.
Gobelin blue.	Deep Drab and Gobelin blue.	Gobelin blue, reds and drabs.	Drabs and blue.	Light drab, warm drab, blue.	Russet yellow and blue.	Russet yellow and blue.	Russet yellow.
Golden Brown.	Deep red or olive.	Deep red or Gobelin blue.	Olives and golden browns.	Light golden tint.	Deep red or deep blue.	Deep red, deep blue deep olives and browns.	Deep golden brown or blue.
Ivory Green.	Greenish cream.	Light sea green and dully yellow with silver.	Very light greenish cream.	Sea green gold and creams.	Absinthe green.	Cream and absinthe green.	Absinthe green.
Lavender.	Lavender.	Deeper lavender, or light blue.	Lavenders and creams.	Very light cream.	Lavender, buff blue, salmon pink.	Lavender, silver, buff, gold blue, salmon pinks.	Yellow.
Light golden tint.	Pale blue.	Dark golden tint.	Medium golden tint, with some blue.	Very light golden tint.	Golden tints of several tones & tapestry colors.	Blue, with some light yellow.	Pale blue.
Olive.	Pompeian red.	Deep red.	Olives and old gold.	Light Olive.	Dark Olive, Reds, and dull deep blues.	Old red.	Old red.
Pale green.	Deep Green.	Greenish gray, with silver.	Silver, greenish gray, pale green.	Silver.	Pale greens, greenish grays, and silver.	Ecu, silver gray and green.	Old rose or green.
Pale straw color.	Golden tint.	Gold bronze and pale straw.	Golden tints, gold bronze & pale straw.	Pale Straw.	Old gold, olives and buffs.	Old gold, pale straw, deeper straw.	Old gold, pale straw and deeper straw.
Pearl gray.	Light blue or pink.	Deeper blue or pink.	Gray and light blue or pink, silver.	Light pearl gray.	Gray, buff and light blues.	Gray, buff, silver, and light pink or blue.	Old rose, old blue.
Salmon red.	Salmon red, pale green gray.	Cream, green gray or pink.	Cream, salmon & copper, greenish gray.	Light cream.	Salmon, cream, copper, gold and silver.	Greenish gray.	Greenish gray.
Sky Blue.	Deep ivory yellow or ecru.	Same tones blending into blue.	Blue and ivory yellow.	Ivory yellow.	Blue gray with yellow.	Ivory yellow, with blue.	Ivory yellow.
Yellow.	Robin's egg blue.	Peacock blue.	Yellows, gray and gold.	Gold or white cream.	Old gold, reddish gold, peacock blue.	Peacock and robin's egg blue.	Blue.
Yellow Orange.	Lemon yellow.	Yellow orange.	Orange and lemon yellow, gold.	Light lemon yellow.	Yellow orange and browns.	Yellow orange, cardinal reds, warm browns and a little olive or blue.	Blue, russet brown.

well as of a drawing room. The table has been devised by one whose knowledge on the subject, we take for granted, is complete, inasmuch as the table appeared in the pages of the *Decorator and Furnisher*.

other, examining a large safe. Below the cut were the words "Looking for Jewelry." A few nights after the ad. appeared in the paper the large glass in his show window was broken by a burglar who secured a

the most perfect system of shelving in existence.

Below these shelves is shown the latest application of the Fletcher patent system

# A MOVING DISPLAY

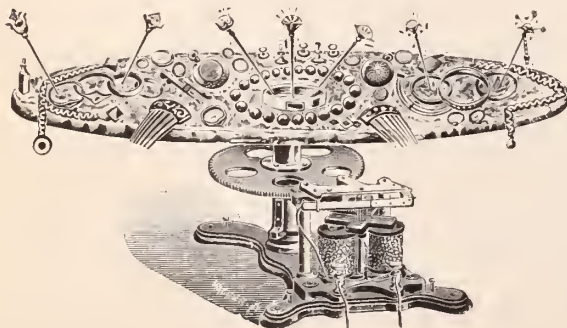

### FOR THE HOLIDAYS.

The Best Attraction in the World—a Moving Advertisement in a Window.

### OUR ELECTRIC REVOLVING SHOW STANDS

Are of various styles, made especially for jewelers. They are equivalent to a four fold increase of Show Window space. It runs steadily ten hours per day, at an expense of two cents per day. Made to be operated by either battery or electric light current.

Send for Circular of Illustrations.

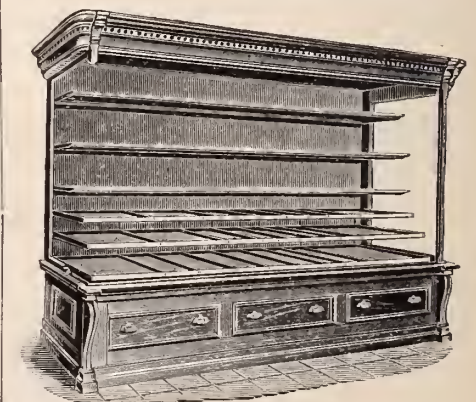

of trays to wall cases. This improvement is on a line with all the productions of the Fletcher Mfg. Co., 259 W. 27th St., New York.

FREDERICK PEARCE,

77 & 79 John St., N. Y.

## A Rare Early Horological Work.

TRAITÉ DE L'HORLOGERIE, MÉCANIQUE ET PRATIQUE. Approuvé par l'Académie Royale des Sciences. Par Thiout l'ainé, maître horloger, à Paris, etc. Avec figures, 2 vols. MDCCXLI [1741]. Avec approbation et privilège du Roy. [Treatise of Horology, Mechanical and Practical. Approved by the Royal Academy of Sciences. By Thiout, senior, master horologer in Paris. With plates, etc.]

Each volume is bound in hog skin, heavy pasteboard covers; Vol. I. opens with the dedicatory page to "His Serene Highness, the Duke of Orleans," whose court watchmaker Mr. Thiout is; next 4 pp. of preface; index, catalogue of authors cited in the work, approbation of the Academy of Sciences, in Paris, August 7, 1740, signed Fostenelle, permanent secretary; next the permission by the censor, and then the King's permission. That compositors then could not read manuscript any better than they can now, is demonstrated by the long list of "Errata." No. of pages in Vol. I, 175; of plates, 44; there should be 50, but 6 have been torn out. Vol. II. continues the paging up to 400; No. of plates, 41. Small 4to. Large type, printed with good black ink on rough paper.

If any of the readers of THE JEWELERS' CIRCULAR imagines that above two volumes are simply a collection of rule-o'-thumb and hodge-podge subjects, he is woefully mistaken. Of course, the very learned and skilful author, Thiout senior, lived at a time when horology still groped in darkness, but it was already groping its way toward the brightly illumined path along which the watchmakers of the present day are journeying—the path inclosed on either side by the thorny hedge of experience, which prevents them from straying into the jungles and morasses of experiment and guesswork. These inclosures were raised by the old masters: Thiout, Le Roy, Berthoud, Romilly, Graham, Arnold, Dent and others of that age, and to these the watchmaker of our times owes all his skill and knowledge in the field horological; they experimented, tested, studied and investigated, until they had evolved shape from chaos, and were pleased when they had successfully wrestled with nature to obtain knowledge of one of its secret laws by which it governs the universe.

It is perhaps proper that we should take, as it were, a retrospective view of what was being done at that epoch so extremely interesting in horology, because it was the period from which sprang that of our days. Huyghens had just applied Galileo's pendulum to the clock, sometime in 1680; Dr. Robert Hook had invented the balance spring in 1660, and the clock anchor or recoil escapement a few years later. Either Graham or Tompion invented the cylinder

escapement about 1698. (Mr. Thiout credits Graham with the invention, giving the cuts of the old style escapement). Harrison had invented the gridiron pendulum; in fact, this list of most valuable inventions would swell unnecessarily, by mentioning everyone. Suffice it to state that at the period of Mr. Thiout all the factors were present to evolve our present marvelously exact timepiece. Three escapements were in principal use; the old De Wyck clock escapement, which consisted of a train of wheels, driven by a weight; it had a vertical or verge escapement with a vibrating balance, but no spring; the balance, instead of being shaped like a fly-wheel, was in the form of a T, upon the two thin projecting arms of which were cut concentric notches, in which two small regulating weights were suspended; this escapement was about becoming obsolete, on account of the application of the pendulum; the second was the verge escapement; the third was the then recently invented cylinder escapement. That both scientists and skilful watchmakers were deeply engaged in the study of horology, is visible in the plates, by the great number of escapements—30—for clocks and watches; none of them, however, have survived the "shock of time," except the three just mentioned.

Happily, several French watchmakers have left us a record of their times and state of the art-milestones in the progress of horology. Perhaps the first of the kind—that is treating of horology in general—was written by Domenicho Martinelli Spolette, an Italian, entitled *Treatise of Elementary Timepieces*, and printed in Venice in 1663. The next was one by the Frenchman, R. P. Alexandre, published in Paris about 1700, who also named his work *Treatise of Horology*. The work under review bears the same title. It is, perhaps, strange that so many horological works should have been written in France about that time, and it might not be uninteresting to inquire into the reasons why.

Under the reign of Louis XIV., all the arts were perfected in France, except horology; it was then as it was until lately and until our American watches taught a different lesson, the universally entertained opinion "that the good old English lever could simply not be beaten by anything under the canopy of the heavens." This preconceived opinion was so deeply rooted that nobody tried to question its veracity. But the Regency finally made a change. Law, the highly intelligent French minister of finance, set about to perfect horology in France for the purpose of retaining the million of francs sent over to England annually for timepieces. He engaged English watchmakers, furnished a plant well

### For BADGES and MEDALS,

Flag Pins, Class Pins, Class Rings

and Special Work of all Descriptions,

SEND TO E. R. STOCKWELL, MANUF'R.

49 John Street,

New York.

# Novelties

.. IN ..

# Diamond Jewelry

.. FOR ..

## FALL SEASON, 1894.

RINGS, STUDS,  
LOCKETS, BROOCHES,  
LACE PINS, SCARF PINS,  
EAR RINGS, EAR STUDS,  
BRACELETS, NECKLACES,  
CORSAGE PINS,  
VICTORIAS,  
CHATELAINES,  
LINK BUTTONS,  
SLEEVE BUTTONS,  
COLLAR BUTTONS,  
CZARINAS, Etc., Etc.

Having imported a large reserve stock of Diamonds, we will not advance any of our prices at present. Dealers making their selections now will have the full advantage of the low tariff prevailing on Diamonds before the Wilson Bill went into effect.

Our stock of mounted goods is unusually complete.

You can save 15 per cent. by buying your Fall Stock now.

Write for a Selection Package.

# Cross & Beguelin

Loose—DIAMONDS—Mounted.

17 Maiden Lane,  
New York.

43 RUE MESLAY, PARIS

appointed in all its details, and placed it under the direction of an Englishman, Mr. Sully. But this excited the jealousy of the English, and the government soon after recalled its subjects, the larger part returning home, thereby leaving "an aching void" in the French watch factory. Just then Julien le Roy appeared, and being known to Mr. Sully, he was appointed director; able French watchmakers were engaged, and shortly after the factory ran under French mastership. It is unnecessary to eulogize the ability of le Roy, as his name stands indelibly recorded on the scroll of fame, and, although he was no finished watchmaker, he was perhaps the most inventive one in France at that time. The English watchmakers of that age were extremely jealous of the knowledge they possessed, and it would have been an act a little short of high treason to publish a work like that under review. The Germans were still endeavoring to recuperate from the effects of the Thirty Years' War, to immediately after plunge into the Seven Years' War, and were therefore no competitors in the art they had invented. Thus the French were undisputed masters in the literature treating of horology.

It would be a hopeless task to critically review these two rare old volumes—first, because watches have been fundamentally changed since that time, and second, the reader would after all gain no insight into the description of one without accompanying illustrations. Nearly every clock shown is encumbered with the complicated trains for showing phases of the moon, date, tides, &c., a custom well-nigh obsolete. Among the tools used are a number for cutting and rounding the teeth, pinion leaves, &c.; spring winders for watches and clocks; for cutting, polishing, dressing, &c.; a fusee; tool for cutting any number of teeth; for regulating the length of the pallets; for regulating depths; for cutting files, and an infinity of other labor saving devices. Among the various details of clocks we have "a pendulum rod which itself corrects the influence of heat and cold," being the gridiron pendulum; a pendulum with equal vibrations (isochronism); pendulum suspen-

sions; the irregularities of the pendulum; the cycloid; demonstrations anent the balance spring used in watches; concerning the rounding of teeth and leaves of pinions, to make the clock more perfect, and a large number of other devices. In fact, every part of the art of horology receives its merited attention, and the author, being a skilful watchmaker, incorporated into his work only those devices and movements which he considered to be the best of the kind and invented by able men.

It is well that men like Thiout have left a record of their times so that the reflective craftsman might turn around occasionally and ask, "How far have we journeyed on our road to perfection?"

The volumes above reviewed are the property of Henry P. Buckley, New Orleans, La., one of the oldest watchmakers in America.

### Movement With Divided Plates.

ACCORDING to the statement of the inventor, Ed. Kummer, of Bettlach, Switzerland, who received a Swiss patent for this novelty, the purpose of this invention is to offer various facilities to the watchmaker as well as repairer. A glance at the two figures, of which 1 represents the interior and 2 the exterior side of the plate, shows that the plate is bisected by a straight cross-section from *e* to *f*, where the two unequal parts A and B are formed. The smaller part A carries the escapement parts, the larger, B, the train. For connecting the two parts, serve the projections *cc* and the screws *dd*. After having loosened these two screws the parts of the plates may be separated.

This bi-partition of the plate renders it possible that the part A, with the escapement parts, and B, with the train, can be manufactured by two different workmen, and in two different factories even at the same time, which under circumstances may result in a considerable saving of time. The making of the train can in this manner be done by less skilful workmen, as it does not require the great precision neces-

sary for the escapement. This invention also favors the principle of division of labor.

This bi-partition is of advantage to the

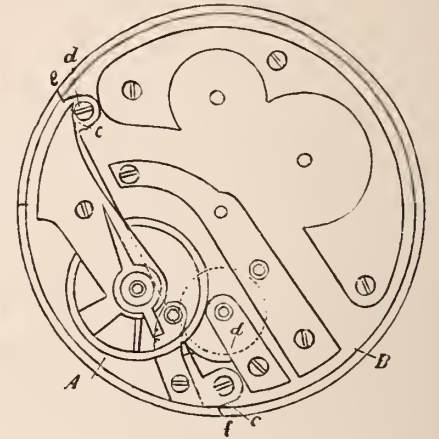

FIG. 1.

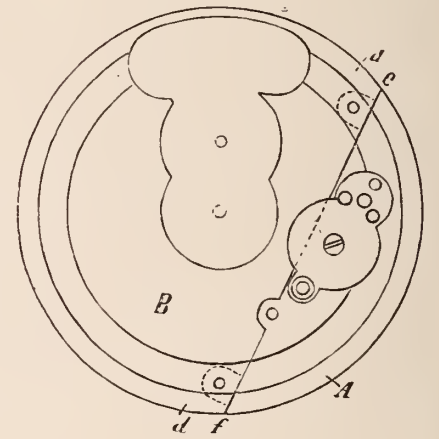
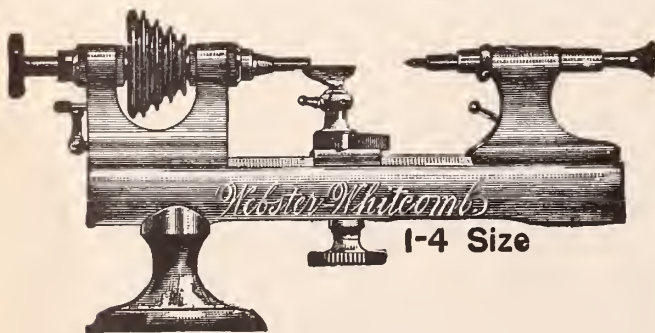

FIG. 2.

repairer, because he may take out part A with the escapement without disturbing the dial which is fastened to the larger part B. Finally, this arrangement does not at all make the watch thicker, which evil pertains to movements in which the escapement is arranged upon a special small plate, which again is screwed upon the main plate. This style calls for a thicker case—of importance in gold cases. The invention described above does away with all these objections and evils.

**Cleanliness in Polishing.**—Repairers never seem to understand the importance of cleanliness in polishing. Rouge which in other hands polishes beautifully, is with them no better than oil-stone dust. Burnishing with a clean brush is of no use in polishing. Nothing but soft bread, kneaded in the palm of the hand to a dirty paste, and the work to be cleaned imbedded in it, will remove dirt properly for polishing purposes; or if a pivot or arbor, polishing in the turns for burnishing, a clean card scraped on the edge with a knife and applied to the polished surface, will clean and dry sufficient for burnishing, or for observing what progress has been made in burnishing.



STRONGEST GUARANTEES.

Quality  
Maintained.

Prices to  
Suit the Times.

Ask for our New  
Prices and  
Terms for 1894.

American Watch Tool Company,  
Chymistry Dist., Waltham, Mass.. Stoney Batter Works.





# RUDOLSTADT

## ART POTTERY.

CONTAINS all the elements required as to designs, decorations and workmanship, in a high grade of Art Goods adapted to the Jewelry Trade, and yields a larger margin of profit than any other class of Pottery.

**L. Straus & Sons,**

SOLE AGENTS,  
42-44-46-48 Warren Street,  
116 Chambers Street,  
NEW YORK.



**..THE LATEST..**  
**Sterling Silver Novelty,**  
**CIGAR CUTTER**  
**AND KEY RING COMBINED.**  
(Patent applied for.)  
WITH OR WITHOUT CHAIN.

MADE ONLY BY  
**ENOS RICHARDSON & CO.,**  
23 Maiden Lane, New York.

## CAMPBELL-METCALF SILVER CO.

FACTORY:  
STEWART ST.,  
PROV., R. I.

N. Y. OFFICE:  
2 MAIDEN LANE.

SAN FRANCISCO:  
112 KEARNY ST.



THE  
"ETON"  
... IN ...  
CREAM LADLES  
ORANGE  
SUGAR  
JELLY  
BON BON  
SUGAR SIFTER  
SARDINE FORK  
BUTTER KNIFE  
BUTTER PICK  
CHEESE KNIFE  
OYSTER FORKS  
ETC.



OUR  
"ETON"  
AND  
"STUART"  
PATTERNS  
ARE IMMENSELY  
POPULAR  
AND SELL AT SIGHT  
WRITE DIRECT  
TO FACTORY FOR  
SAMPLES  
AND PRICES.

**FANCY**  
.. IN ..  
**SCARF PINS**  
AND LINKS.



**FIGURES**  
STERLING SILVER,  
Enameled in Colors.

Dudes, Chinamen, Policemen, Sailors, Orators, Cadets, and all other Shapes Made.  
SEND FOR SAMPLES. QUICK SELLERS.

If your Stock does not include our **COLCONDA GEM** Line you are losing sales. This Stone is Mounted in Studs, Scarf Pins, etc., in Solid Gold and Plate.  
If your jobber doesn't keep these goods write us and we will send you the address of a jobber in your vicinity who does. Every card bears the words "THE GOI CONDA GEM, Reg'd." all others said to be "equally as good" are spurious. Bear this fact in mind

**R. L. GRIFFITH & SON, = PROVIDENCE, R. I.**

**HILDRETH M'F'G CO.,**  
53 MAIDEN LANE, NEW YORK.

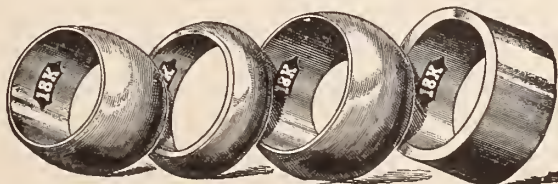

Standard Quality. Standard Prices. Finest Finish.  
**Plain Solid Gold Rings.**

# FERDINAND BING & Co.,

NEW YORK:  
106 GRAND ST.

PARIS:  
74 RUE D'HAUTEVILLE.

BERLIN, DRESDEN, VIENNA, ST. PETERSBURG, MOSCOW.

NOVELTIES IN ALL OUR WELL KNOWN LINES.

**New Goods. New Prices.**



A GROUP OF REPRESENTATIVE BRIC-A-BRAC IN OUR SHOW ROOMS.

## SPECIALTIES THIS SEASON:

RUSSIAN BRONZES, RUSSIAN ENAMELS, RUSSIAN LACQUERS,  
RUSSIAN NOVELTIES IN MALCHITE, LAPIS-LAZULI, QUARTZ, and PORPHYRY.

**CARVED IVORY STATUARY.**



## Recent Designs in Pottery.

IF the recent designs for pottery ware cannot be described as new it must be admitted that they are most varied, and many of them are pleasing to look upon, says an English authority. So many artists of talent have lent their aid to the decoration of the potter's art that it would appear almost an impossibility to construct a new school of art. As a matter of fact, the forms for ornamentation remain nearly the same as they were years ago, and the skill of the artist would appear to be directed mainly in fresh adaptations of them; and how this may be accomplished would puzzle many minds. Imagine for a moment the number of manufacturers, the numerous artists they have employed, and the thousands of patterns that year after year have been produced, and then we are face to face with the perplexity of the potter, in his endeavor to answer continually the everlasting cry for "something new."

Truly, the position of the manufacturer is not an enviable one when these things are borne in mind. And yet in adverse, as well as prosperous times, he has hitherto borne his lot with unexampled patience amongst industrial arts; and to his credit, be it said, has hitherto met the demands that have been made upon him. So it is that season in and season out we find that new designs of pottery decoration, as well as altered and sometimes original form, meet the eye. How it is accomplished it is difficult to explain, unless it be that the designer brings his own individuality to bear upon his work. Latterly, the teaching given in the art schools, and a widening knowledge of technique, must have had a great influence upon pottery design, from the fact that it has enabled the artist to understand the true aim of his work. It is but reasonable to suppose that the productions of a man without art knowledge must be very crude indeed, and would not at any rate meet with a market in the present age. And this our manufacturers thoroughly understand, and as a consequence seek to obtain the best artists procurable. Copyists there ever have and ever will be, and it is astonishing under all circumstances that such variety, such admixture of taking

styles, and such beauty of expression are produced.

But the modern potter has an advantage which his predecessors in the art did not possess. He has an almost endless variety in color, and new tints are constantly being added to his palette. The power these give to the designer and colorist is marvelous, and they enable him to give an attractiveness and a life to many a pattern which otherwise would be worthless. Throughout the world there would seem to be a growing appreciation of colored designs, and latterly this is very marked in the orders which reach our manufacturers from the west. Only a few years ago the demands from that quarter of the globe were mainly for white ware, but now a better class of goods, painted either under or on the glaze, is demanded, and this shows that the perseverance of the British potter is not without its reward. To put it otherwise—our manufacturers in improving their designs and in applying to them so extensively enameled tints, have created a market for a superior class of ware, and no doubt the demands for it will continue to expand.

In later decoration it will be noticed that our designers do not confine themselves exclusively, as they did a few years ago, to patterns of a geometrical character, but are looking to the wide field of nature for their ideas and inspiration. And their success has been great. Floral, animal, marine life and landscape now give a beauty and a charm to our pottery which is really wonderful to behold, and consequently we do not hear now of our pottery lacking in an art sense. That cry will not be heard again, for it does not seem at all probable that our manufacturers will make a retrograde movement. On the contrary, the advances which are being made in art culture in England go to show that the future generation of designers will be in a position to make still further progression in the decoration of the art ware of our native craftsmen.

The F. Kroeber Clock Co., 360 Broadway, New York, are showing little carriage clocks in four colors, in porcelene instead of brass cases. The alarm clocks in porcelene cases are proving highly successful.

## The Rambler's Notes.

WHAT THE RAMBLER SAW AND HEARD AMONG THE DEALERS IN ART POTTERY, CUT GLASS, BRONZES, ETC.

NOVELTIES IN FRENCH china novelties are LIMOGES PORCELAIN. being handled by the

jewelry trade more and more extensively every year and a glance at the many beautiful lines now on the market will make one understand that the jewelry trade is the logical channel through which goods of so rich a character should be disposed. One of the largest and richest assortments of Limoges novelties of which the metropolis



THE ROSE PATTERN.

can boast is that shown by P. H. Leonard at the showrooms, 76 Reade St. Here are displayed ice cream, tête-à-tête, after dinner coffee and other sets, desk appointments,



THE FOSTER PATTERN.

toilet articles, trays, cups and other table novelties in a variety too great to enumerate. Many are the artistic designs and decorations introduced this season, among

**The Connoisseur.**

(Continued from page 47.)

which are the three illustrated here. The brush and comb tray is in the new Richfield pattern, the pen tray in the Rose, while the dessert plate may give an idea



RICHFIELD PATTERN.

of the beauties of the Foster shape. Among the new designs particularly adaptable to pieces of this nature, are the Psyche, Lys, Louis XVI., Trocadero, Sevigne and Coquille.

**LAMPS, SHADES, TABLES, ETC.** AN interesting assortment of banquet and boudoir lamps is shown by A. M. Wilcox, 23 Park Place, the New York agent for the lamps and

metal fancy goods of the Craighead & Kintz Co. The styles are many and rich. Mr. Wilcox, who is the selling agent for the lamp shades of A. Feigl, and the brass tables, etc., of the Detroit Sheet Metal & Brass Works, is also showing at his ware-rooms a full assortment of each of these lines.

THE BEAUTIFUL

**I**N Cantagalli ware, Italian ware, large urns and vases are shown in great profusion at the New York ware-rooms of Ferdinand Bing & Co., 106 Grand St. The pieces range from two to about three feet high, and show various shapes with handles formed of snakes, dragons and odd figures. There are two decorations; one a rich blue, has grotesque figures and landscapes, while the other consists of multichrome floral decorations on a white ground. This ware also comprises candlesticks and a few other small pieces.

INTERESTING ALABASTER FIGURES, GROUPS ETC.

**M**ANY artistic pieces are to be found in the new line of alabaster figures, groups and busts which Bawo & Dotter have just put on display at their ware-rooms, 30 Barclay St., New York.

The greater number are large busts and statues from two and one-half to three and one-half feet high, though many medium and a few small sized pieces are also shown. Prominent among the large groups are "Paul and Virginia" and "Faust and Margaret." The large busts show many cupids, cherubs and a number of juvenile subjects.

THE RAMBLER.

**Plates With Portraits of Historical Personages.**

**"A** VERY great novelty and especially desirable for full services are our plates bearing portraits of famous historical men and women," said Manager Lyons, of the Chicago house of Lazarus, Rosenfeld & Lehmann, 66 E. Lake St., and the plates are indeed very desirable, either singly or in sets. The firm are also showing a fine line of Bohemian glass with gold decoration and bisque figures in artistic forms of jardinières, etc. Orders are numerous from all sections also, for cut glass, and novelties are selling well. Parties unable to go to Chicago for personal selection can with greatest confidence leave the selection to Mr. Lyons, a man of wide experience in art glass and porcelains and thoroughly competent to judge of the best needs of the various parts of the country.



**THE QUESTION**

WILL IT TARNISH ?

Need not be asked if your Tissue Paper bears this label.

MANUFACTURED BY

**C. H. Dexter & Sons,**

WINDSOR LOCKS, CONN.

◁ BE SURE YOU GET THIS BRAND ▷

It has been adopted and is now used by the leading manufacturers of this country.

**AIKIN, LAMBERT & CO.,**

CHICAGO BRANCH: 103 State Street.

No. 19 MAIDEN LANE, NEW YORK.

Manufacturers and Exporters  
Gold Pens, Holders, Pencils,



Toothpicks and Novelties.

**MERCANTILE**



**FOUNTAIN PEN.**

# BAWO & DOTTER,

IMPORTERS, MANUFACTURERS AND  
COMMISSION MERCHANTS,

26, 28, 30 & 32 Barclay Street, = = New York.

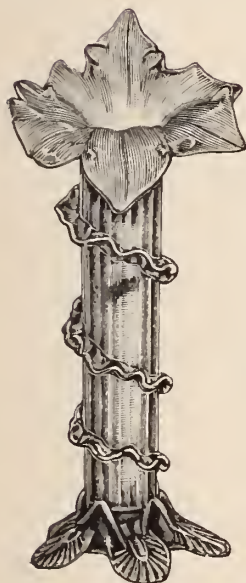
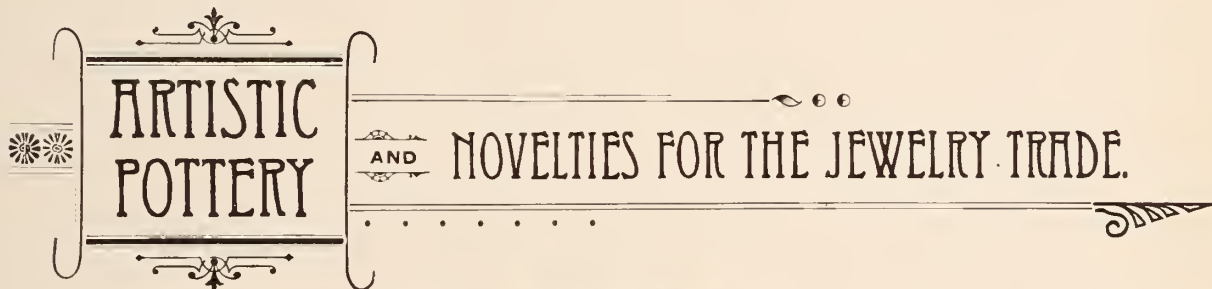

### Flower Tubes.

Fine English Crystal, Nürrenberg Green and Opalescent.

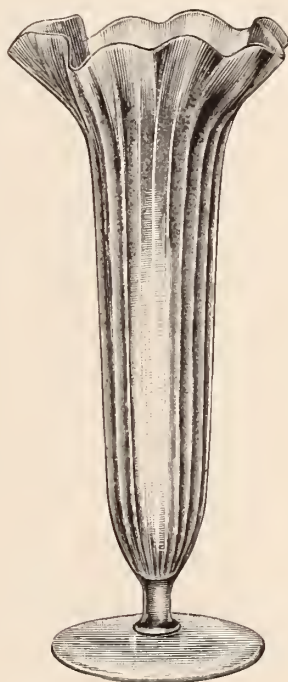

Also a large line in Fancy Shapes, richly decorated in gold. Suitable presents for the Holidays.

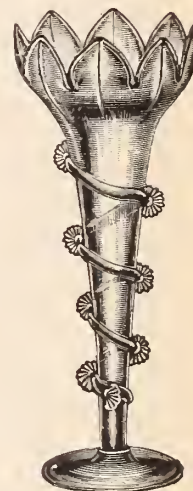

DRESDEN AND ROYAL TEPLITZ CENTRAL DRAFT LAMPS.  
THE LARGEST LINE IN THE CITY.

### PARIS SPECIALTIES.

A large line of gilt mounted VASES, CARD RECEIVERS, CANDLESTICKS, Etc., Etc., Etc. FAIENCE CLOCKS, and GILT BRONZE CLOCK SETS. SEVRES PLATES, CUPS and SAUCERS. BRONZES, newest designs and latest colors.

A full line of COALPORT, MINTON, DOULTON, ROYAL WORCESTER, COPELAND, WEDGWOOD, Etc., Etc., Etc., also ROYAL DRESDEN, ROYAL VIENNA, ROYAL BONN, TEPLITZ, ROYAL HAN-OVER, and other celebrated makes.

Just received, a large invoice of

### ITALIAN MARBLE STATUARY.

Never before have we been better prepared to meet the growing demands of Jewelers, for Artistic Novelties in Pottery than at the present season.

ALL TASTES CAN BE SATISFIED.

New York Warerooms and Office :

26, 28, 30 & 32 Barclay Street.

P. O. BOX, 1872.

### Factories :

Limoges, Steinschoenau and Carlsbad.

Paris, 32 Rue de Paradis.

Hamburg, Alter Wall, 74.

London, 44 Jewin Street,

Berlin, Commandanten Street, 60.

OUR MOTTO--Quality and Price Speaks Louder Than Words.

**"SECURITY PIN GUARD."**

Can be Used on Scarf or Ladies' Pin.

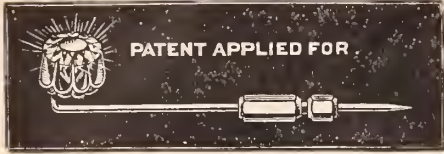

85c. Dozen Gold, \$6.00 } Doz.  
 Net Cash. Silver, 3.00 } Net Cash  
**DISCOUNT TO JOBBERS.**  
 Security Mfg. Co., 7 Astor House, B'way, N. Y.

**FERD. FUCHS & BROS.**

**SILVERSMITHS,**

MAKERS OF STERLING SILVERWARE,

808-810 Greenwich St., New York.

WHITE'S EYE SHADE. **W. B. WHITE & SON**  
 MANUFACTURERS OF



Spectacle and Eye Glass  
 CASES

90 SOUTH STREET, BOSTON.

Special Cases made to order for Optical Trade. Cases for Trial  
 Lenses. Opera Glasses recovered, etc. Chatelaine Spectacle Cases  
 Metal Bound Leather Cases for combs, scissors, etc. Over forty kind  
 of cases manufactured.

**The Other Side of Life.**

Doo D. (to jeweler)—I brought back this engagement ring that I bought yesterday.  
 Jeweler—Didn't it suit?  
 Doo D.—I didn't.—*Philadelphia Record.*

It is a sad spectacle to the non-advertising optician to see his rival's store crowded.—*Printer's Ink.*

THE SHOPPER—I'd like to buy that lovely lamp shade, but I can't afford to pay \$10 for it.

THE SALESMAN—Well, madam, I'll make the price \$9.99.

THE SHOPPER—Oh, how good of you! I'll take it.—*Chicago Record.*

WIFE—The price of the clock was \$10, but I got a discount, so it only cost me \$8.

HUSBAND—Yes; but you could have got the same thing at Beezle's for \$5.

"That may be; but then, Beezle wouldn't have taken off anything."—*Boston Post.*

MAUD—Have you a collection of spoons, dear?

MABEL—Yes, you will find their pictures in the album on the table.—*Truth.*

A STRATEGIST.

VAN COURTLAND PARK.—I have just bought my wife a diamond ring for \$250.

MURRAY HILL.—I had no idea you were so extravagant.

"Extravagant! My dear fellow I will save lots of money. That's why I have bought it."

"I don't catch on."

"Why, man alive, I'll save \$500 on kid gloves."—*Texas Siftings.*

MATRIMONIAL DANGERS.

A.—I hear that since you are married you are no longer attentive to your wife, that you never say a kind word to her.

B.—Well, she is to blame for it. I have had some sad experiences by being amiable and complimentary. Not long since I compared her teeth to pearls, and the result was she badgered me into buying her a \$200 pearl necklace, so you see I can't afford to be complimentary.—*Texas Siftings.*

**GEO. W. SMITH & CO.,**

MAKERS OF

**HIGH · ART · FURNITURE,**

ESPECIALLY ADAPTED FOR

**JEWELRY AND ART TRADE.**

Cabinets, Pedestals, Jardiniere Stands, Onyx Top Tables, 5 O'Clock Tea Tables, Curio and Souvenir Spoon Tables and Cabinets.

**HALL CLOCK CASES.**

FACTORIES,

NEW YORK SALESROOM,

3907-19 Powelton Ave., Phila.

818 Broadway, H. P. Vollmer, M'g'r.

**RICH CUT GLASS.**

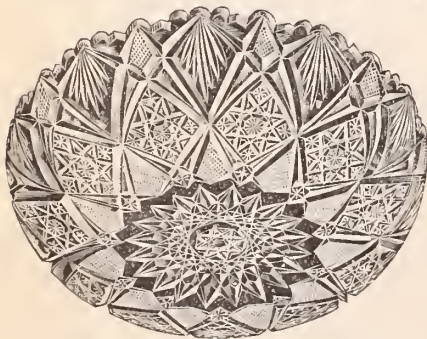

7 INCH NAPPY. SAVOY CUTTING. BOTTOM VIEW.  
 The illustration does not fully show the handsomely scalloped edge.

**T. B. CLARK & CO., Inc.,**

860 BROADWAY, NEW YORK,

Factories, HONESDALE, PA.

North East Cor. 17th St. and Broadway.

**W. F. Evans & Sons**

SOHO CLOCK FACTORY,

HANDSWORTH, BIRMINGHAM, ENGLAND.

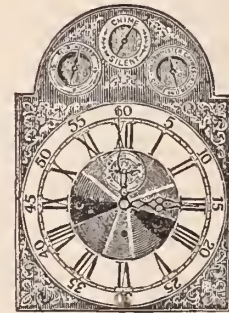

GRANDFATHER CLOCK.

Manufacturers of  
**CHURCH,  
 CHIME &  
 QUARTER  
 CLOCKS,  
 SCHOOL AND  
 HOUSE CLOCKS**

With arch brass dials to chime upon Bells, Gongs, and Harrington's Patent Tubes.

ESTABLISHED 1805.

**J. R. WOOD & SONS,  
 14 JOHN STREET, NEW YORK.**



**PLAIN SOLID GOLD RINGS.  
 SEAMLESS PLAIN SOLID GOLD RINGS.  
 ENGRAVED AND CHILD'S RINGS.**

No Ring Stamped Different from Quality. Send for Catalogue and Price List.

Old Gold and Silver received and estimated on: If amount allowed does not give satisfaction, notify at once and will return at our expense, in same condition as received.

**WOOD & HUGHES,  
 STERLING SILVERWARE MANUFACTURERS**

New York Agents for the Derby Silver Co.'s  
**FINE QUADRUPLE PLATED WARE,**  
 No. 16 JOHN STREET, NEW YORK  
 206 Kearney St., San Francisco, Cal.  
**HASKELL & MUEGGE, Agents.**



# HINRICHS & CO.,

29 & 31 Park Place, N. Y.

## HOLIDAY GOODS FOR JEWELERS.

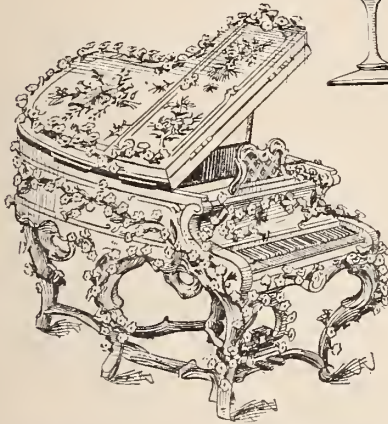

ITALIAN MARBLE BUSTS,  
PARIAN BUSTS and FIGURES,  
BISQUE FIGURES and GROUPS,  
FRENCH CHINA CRACKER JARS,  
CHOCOLATE POTS, TRAYS, BOWLS,  
SOUVENIR A. D. COFFEES, TEAS, Etc.



ST. GERMAIN AND GERMAN-AMERICAN STUDENT LAMPS.

### BRIC-A-BRAC AND ART POTTERY.

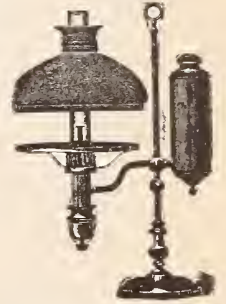

SEND FOR CATALOGUES.

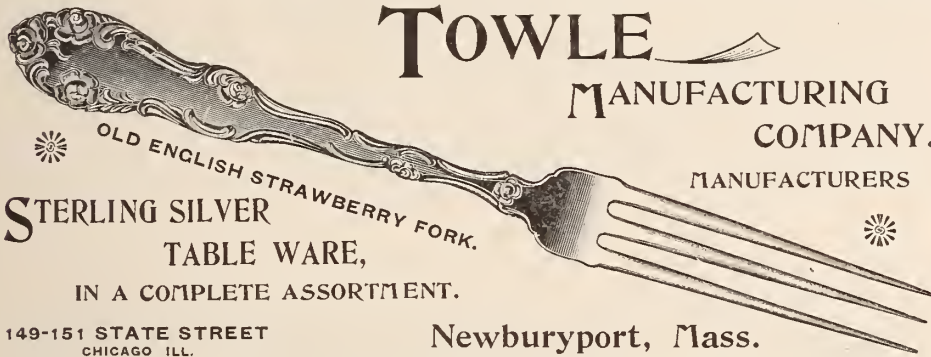

**TOWLE**  
MANUFACTURING COMPANY.  
MANUFACTURERS

OLD ENGLISH STRAWBERRY FORK.

STERLING SILVER TABLE WARE,  
IN A COMPLETE ASSORTMENT.

149-151 STATE STREET  
CHICAGO ILL.

Newburyport, Mass.

## BURGLARY INSURANCE.

**Fidelity AND Casualty Co.**  
OF NEW YORK

INSURES Safes and their Contents  
**Against Burglary.**

For Particulars, address the Company,  
140-146 BROADWAY, NEW YORK

# The Best Chatelaine is the Lady Racine.

## STEEL CASES & SILVER CASES.



10 LINE.

- Made in 10 Line Open Face.
- “ 11½ Line Open Face and Hunting.
- “ 13 Line Open Face and Hunting.

THE SILVER CASES ARE 0.935 FINE.  
THE MOVEMENTS HAVE 10 JEWELS  
THE ENGRAVINGS ARE CHOICE.



3 LINE.

### MADE IN 12 LINE OPEN FACE.

In Silver Cases only.  
Case 0.800 Fine with a 6 Jewel Movement.  
Expressly Gotten Up to Suit the Times.



12 LINE

## A GOOD Chatelaine Watch at a LOW PRICE.

Do not fail to ASK YOUR JOBBER FOR THE NEW  
12 LINE LADY RACINE in 0.800 Cases.

# B. & W. B. SMITH,

220 West 29th St., New York.

WE ISSUE NO  
PRICE LISTS.  
MAKE TO ORDER  
ONLY.

Estimates Given  
on Application.



CALL AND SEE  
US WHEN  
IN NEW YORK.

We have a  
FINE LINE OF  
Sample Cases  
ON EXHIBITION.

PORTION OF F. W. SIM & CO.'S STORE. TROY, N. Y.

FITTED UP ENTIRE BY B. & W. B. SMITH, 220 WEST 29TH STREET, NEW YORK.

## S. F. MYERS & CO.,

Manufacturing and  
WHOLESALE JEWELERS,  
1895 Issue, No. 39.

### OUR ROYAL CATALOGUE

Illustrates all that is new, unique  
and desirable in

everything that pertains to jewelry.  
600 pages, size of this publication.  
Free to dealers.

SEVEN DOUBLE FLOORS.  
TWENTY-TWO DEPARTMENTS.

Myers Buildings, 48-50 Maiden Lane,  
33-35 Liberty St., New York.

## U. S. SMELTING & REFINING WORKS.

Sweep Smelting and Assaying. Platinum in Plate and  
Wire. Chemically Pure Copper. Ore and Bullion  
Assays a specialty.

Highest prices paid for old gold and silver.  
Sole manufacturers of Phoenix Flux  
and Eureka Alloy.

M. WOLLSTEIN, 25 John St., New York.

## Diamond Polishing Machines.

We build these machines complete with latest improve-  
ments also polishing wheels, tongs, dousps, weights,  
shafting, belting, ventilating fans, gear-cutting, die blanks,  
etc., We do general repair work on jeweler's machinery.

THE ARTHUR CO.,

General Machine Works,  
86 JOHN STREET NEW YORK.

DIAMONDS.

**C. COTTIER & SON,** IMPORTERS OF  
PRECIOUS STONES,  
14 MAIDEN LANE, NEW YORK.

C. A. RICHARDS, Agt. 151 Weybosset St., Prov., R. I.

FANCY GEMS.

SEND FOR PRICE LISTS. **FOOT-LATHES BENCH-SHEARS** **JEWELERS' MACHINERY** DRAW BENCHES ETC. **W.W. OLIVER, BUFFALO, N.Y.**

OUR . . .  
**SPECIALTY**  
The Largest Stock of  
**CHIMING**  
AND  
**STRIKING**  
**HALL CLOCKS**  
ever shown.

**Chas. Jacques**  
CLOCK CO.,  
22 Cortlandt Street,  
NEW YORK.

**SAFES FOR JEWELERS.**  
**MOSLER, BAHMANN & CO.,** 518 BROADWAY  
NEW YORK.  
Patent Fire and Burglar Proof Safes.

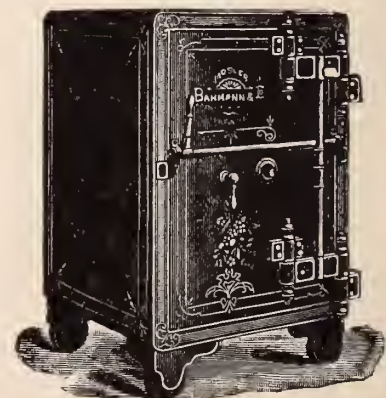

Large Assortment Always on Hand.  
Send for our Representative.  
Special Safes to Order.  
Jewelers' Safes a Specialty.

**IT PAYS** TO KEEP IN TOUCH WITH TRADE AFFAIRS. **THE JEWELERS' CIRCULAR,** For 4c. a Week will do it. **Subscribe.**

**DIAMONDS** and Cutters. **L. & M. KAHN & Co.,** 172 Broadway, **DIAMONDS**  
Cor. Maiden Lane, N. Y.



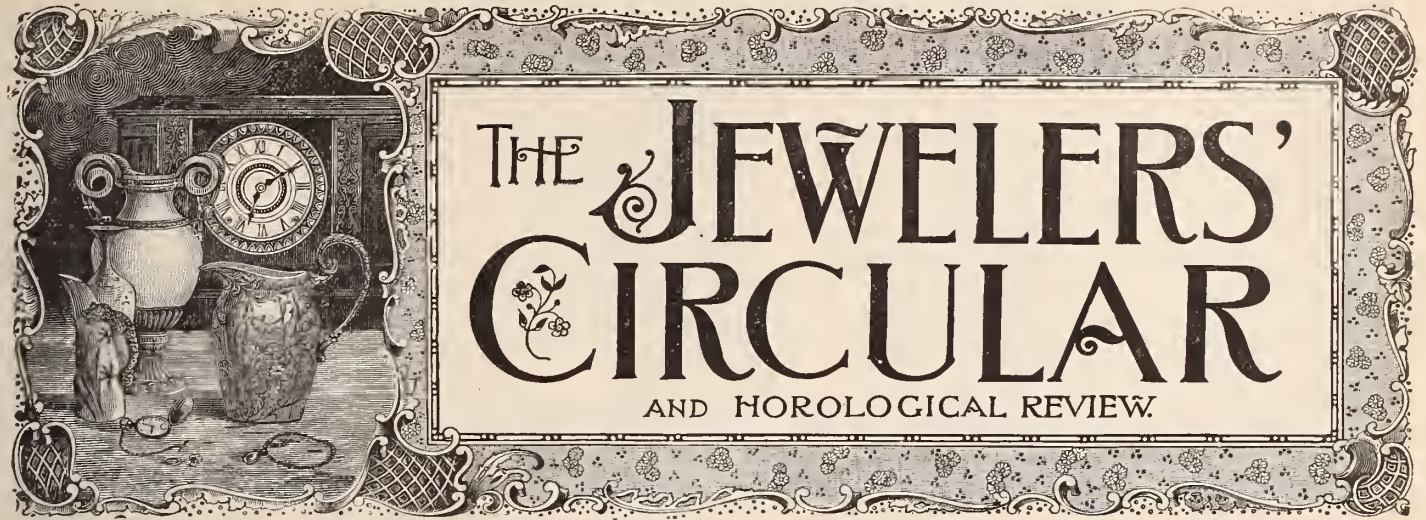

Copyright by THE JEWELERS' CIRCULAR PUB. Co.

189 Broadway, New York.

Entered at the Post Office in N. Y. as second-class matter.

VOL. XXIX.

NEW YORK, WEDNESDAY, NOV. 14, 1894.

No. 16.

### A REMARKABLE RELIC IN THE BRITISH MUSEUM.

THAT an object, unique as the most perfect specimen of a past art, and equally interesting on account of its historical associations, could so lose its identity as to go a-begging for a purchaser, at an almost nominal price, seems incredible in this epoch of ours, so interested in every scrap that belongs to the past. It looks too like the realization of every collector's dream to be true; for who is he, in the world of curiosity searchers, be his purse long or short, who has not fancied that some day he would be selected by fate to find the anonymous treasure that is to be bought for a song? However, during the Autumn of 1883 such an opportunity was offered to a score of the keenest of Parisian connoisseurs.

The exceptional object was a gold cup, with a lid, 11 inches in height from base to summit. It was profusely decorated with admirable compositions in enamel. On the lid and bowl these devices represented scenes from the life of St. Agnes, on the foot the emblems of the four evangelists; even the interior of the lid and bowl were ornamented with medallion motives—on the whole, a gorgeous piece of orfèvrerie, reflective of the æsthetic sentiment and style of the fourteenth century. But, apparently, a mood of distrust was then prevalent among our connoisseurs. "La mariée est trop belle," say the French, when the

fault of something is to be too handsome. So it was with the enameled chalice. The

Besides, there were other causes for suspicion. The interior of the chalice was decorated, and it is well known that the chalice serving to celebrate the mystery of the mass is not to be ornamented inside. Then there was, just below the bowl, a Latin inscription in characters of the seventeenth century; how could these letters agree with the Gothic Latin of the mottoes inscribed in the scrolls accompanying the scenes from the life of St. Agnes? This was a gross anachronism that betrayed the counterfeiter. So judged our connoisseurs. They who are generally so jealous about showing private initiative in matters of that kind seemed to have agreed with one another not to yield to temptation. The man who offered it for sale—a Spaniard who spoke French very imperfectly—had nothing to say tending to establish the authenticity of this rather strange objet de vertu. He simply presented it on its own merits; the only information he could advance was that he had brought it from his country, and he did not conceal the fact that he was very desirous of selling it. So he went hawking it about, from such authorities as M. Fr. Spitzer, M. du Sommerard, etc., to the

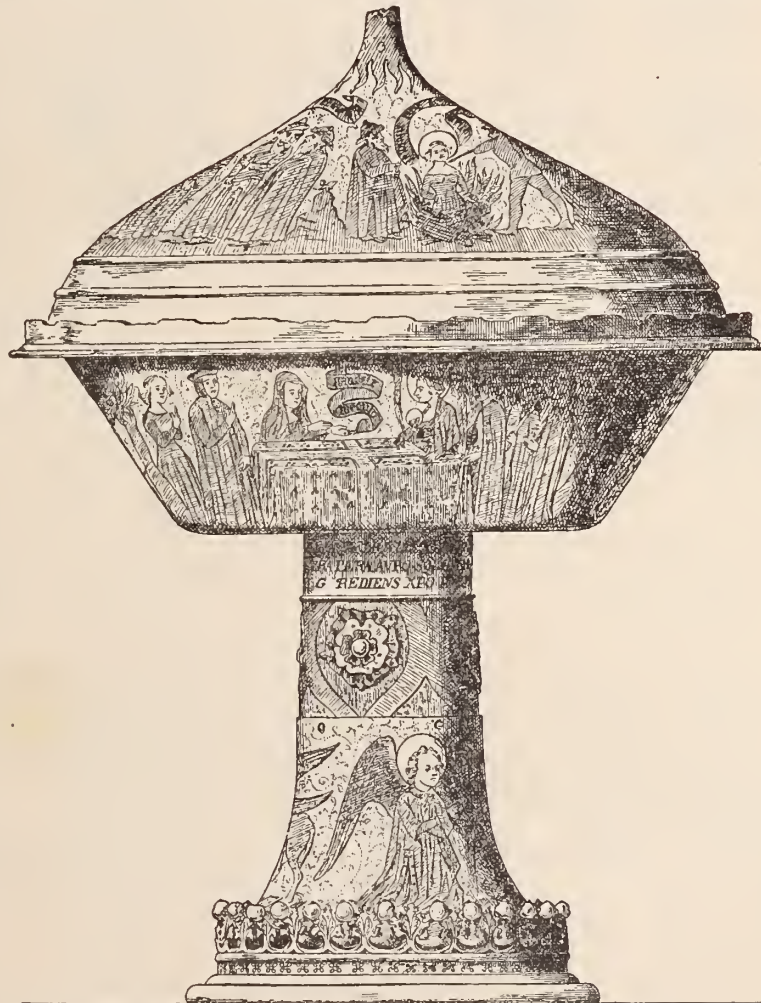

ENAMELED GOLD CUP OF THE KINGS OF FRANCE AND ENGLAND.  
ENGRAVING REPRODUCED FROM "THE COSMOPOLITAN."

enamels were pronounced too perfect, the quality of the workmanship too fine, to be connected with the antiquity the aspect of the object implied.

tribe of brokers in curios who people the neighborhood of the Rue LaFite—only to meet with refusal everywhere.

Finally, he was sent to Baron Jérôme

THESE SUPERIOR GOODS ARE SOLD, NOT CONSIGNED.

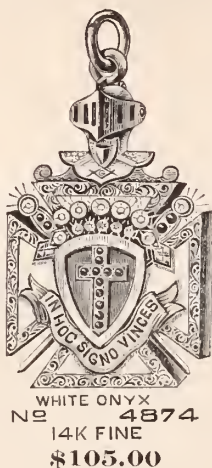

SEE THE TRADE MARK.



SOLID GOLD

LAPEL BUTTONS \$4.50 Each.

No 4870



SOLID GOLD EMBLEM GOODS CARRIED IN STOCK AND ...



SOLID SILVER.



ORDER NOW.

ALL PRICES HERE QUOTED ARE SUBJECT TO THE USUAL CATALOGUE DISCOUNTS.

Princess Ring Manufacturers, Hays Building, 21 & 23 MAIDEN LANE, N. Y.

# LÉON J. GLAENZER & Co.,

80 and 82 Chambers St., New York.

—♦♦—  
**Novelties and Specialties in every Department.**  
—♦♦—

**Clocks.** Gilt, Porcelain, Enameled and Bronze, Crystal Regulators, Traveling Clocks, Hall Clocks with English Chime Movements.

**Bronzes.** Busts and Statues in real and imitation art Bronze and all the Novel Decorations.

**Lamps.** Banquet, Piano, and Princess Lamps, in Decorated Porcelain, Gilt Bronze and Enamel and other combinations.

**Fine Decorated Porcelains and Glassware.**

Sèvres Vases, Plates, Candlesticks, Inks, Flower Holders, Card Receivers, Etc. Table and Decorative Glass.

**Toilet Articles.** All kinds of Brushes, Manicure Sets, Hand Mirrors, Etc.

**Onyx Pedestals and Tables, Bric-à-Brac Cabinets.**

ALL GERMAN POTTERIES.

Dresden, Royal Bonn, Carlsbad, Teplitz, Etc., Etc.

# Novelties

.. IN ..

# Diamond

# Jewelry

.. FOR ..

FALL SEASON,  
1894.

RINGS, STUDS,  
LOCKETS, BROOCHES,  
LACE PINS, SCARF PINS,  
EAR RINGS, EAR STUDS,  
BRACELETS, NECKLACES,  
CORSAJE PINS,  
VICTORIAS,  
CHATELAINES,  
LINK BUTTONS,  
SLEEVE BUTTONS,  
COLLAR BUTTONS,  
CZARINAS, Etc., Etc.

Having imported a large reserve stock of Diamonds, we will not advance any of our prices at present. Dealers making their selections now will have the full advantage of the low tariff prevailing on Diamonds before the Wilson Bill went into effect.

Our stock of mounted goods is unusually complete.

You can save 15 per cent. by buying your Fall Stock now.

Write for a Selection Package.

## Cross & Beguelin

Loose—DIAMONDS—Mounted.

17 Maiden Lane,  
New York.

43 RUE MESLAY, PARIS

Pichon, who owns one of the most remarkable collections of antique jewelry that exists. The moment Baron Pichon held the cup in his hands he saw in it what others had failed to see. This is not to say that the doubts evoked by the refusal of so many competent judges were entirely banished by a mere glance at the object; on the contrary, he also refused to purchase it. But scarcely had the Spaniard turned his back, when a servant was sent after him. The first impression had been the strongest; Baron Pichon asked to keep the cup until next day, and when the man came back for his answer, after some bargaining, the baron remained proprietor of it for the sum of nine thousand francs. This new acquisition to a collection reputed most exclusive was greeted with a pretty concert of astonishment, each note pitched according to the individual's idea of the baron's folly. To the rather ironical congratulations he had but one answer: "Que voulez vous? The cup pleases me sufficiently for the money I paid for it."

Indeed, what he had done was not so extravagant, after all. The cup weighed 2,105 grammes of gold; that is, represented a rough value of 6,700 francs. Therefore, in case he really had been taken in, a margin of not quite five hundred dollars was not an excessive sum to pay for the handiwork of a modern artist of such talent as the imagery in enamel indicated. On the other hand, if the object proved of real antiquity, then it was the most curious remnant of orfèverie decorated with translucent enamels that had reached our time.

The care of studying the quality of the enamels was secondary in Baron Pichon's estimation, to the fascinating problem that lurked in the inscription, which had frightened off the amateurs to whom the cup had been previously offered. It was much abbreviated, and, when completed, read thus:

"Gazæ sacrae ex Anglia reliquias pacis inter reges factæ monumentum cratera auro solidum Johannes Velasquius Comestabularius inde Regi Britanniae gratus re-

dieus Christo pacificatori dedicat."

In English: "John Velasco, constable, grateful to the King of Great Britain, consecrates, on his return from that country, to Christ, the pacifier, this cup of massive gold, remnant of the royal treasury of England, and monument of the peace concluded between the kings."

The more the new owner of the cup studied the wording of this dedication the more convinced he felt that no counterfeiter could have been so learned as to be familiar with the abbreviations proper to the time, or to have known the minor points of history to which the inscription referred. It was evident that this inscription was commemorative of an event, and that it had been added at a more recent epoch. Then, was it not possible that such an event as a peace concluded between the kings of England and Spain might be recorded somewhere, either in history or chronicles? If so, and the record could be found, it was probable that mention would be made also of the memento of that peace; surely, the gift was noble enough to have been registered! Such, at any rate, was the reasoning of a bibliophile like Baron Pichon, who believed that everything could be found in books, and with this belief he set to work to solve the problem.

For nearly ten years Baron Pichon remained the proud possessor of the cup. Finally, in 1892, after much negotiation, he ceded it to the British Museum, for the sum of £8,000. It stands to-day in the jewel room of the great museum, facing the Portland vase, with the following legend upon a label:

"Enamelled gold cup of the kings of France and England, with subjects from the life of St. Agnes, given to Charles VI. of France, in 1391, by his uncle, Jean Duc de Berry, afterward in the possession of the kings of England, from Henry VI. to James I., who gave it, in 1604, to Don Juan Velasco, constable of Castile.

"Purchased by subscription, with the aid of the treasury, 1892"

*From The Cosmopolitan.*

## THE BOWDEN

# SEAMLESS RING

IS MADE ONLY BY

## J. B. BOWDEN & Co.,

Makers of Finger Rings of every Description.

REMOVED FROM BROADWAY AND JOHN STREET,  
TO 3 MAIDEN LANE,  
NEW YORK.



# "DELIBERATE CALCULATION"



IS ADMIRABLY PORTRAYED ON THIS FRENCH CHINA PLATE BY OUR DECORATOR,



BUT A BRIEF EXAMINATION of our CATALOGUES will convince you that he who plays a "winning game" with the **Purchasing Public** can do no better than select liberally from them.

— ONE CENT —

the price of the postal you send us, will bring back a book  
TELLING WHAT \$50 WILL BUY IN]

**::: CUT GLASS :::**

Then there is **HOLLOW WARE** of every description,  
**FLAT WARE**, than which no better is made.  
. . . . . NOVELTIES INNUMERABLE. . . . .

## A WORD ABOUT CROWN PAIRPOINT FRENCH CHINA.

The **JEWELER** is not, generally speaking, an importer, yet he sells as nice a class of trade as exists. He can sell Fine China and Cut Glass as easily as Watches and Jewelry or Diamonds. Now we are importing genuine China blanks and decorating them here. We will import—you can buy from us. It will pay you well to talk with us about this.

SILVERWARE CATALOGUE No 10.

CUT GLASS CATALOGUE No. 11.

## PAIRPOINT MFG. CO.,

BRANCH STORES: 46 Murray St., N. Y.; 224 Wabash Ave., Chicago; 220 Sutter St., San Francisco.

Factories and Studio: NEW BEDFORD, MASS.

### CROUCH & FITZGERALD.

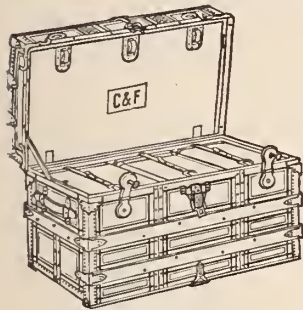

Jewelry Trunks  
and Cases,  
161  
Broadway,  
Bet. Cortlandt and  
Liberty Sts.,  
688 B'way,  
701 6th Ave.,  
NEW YORK.

**FLAT WARE AND  
HOLLOW WARE**  
STAMPED

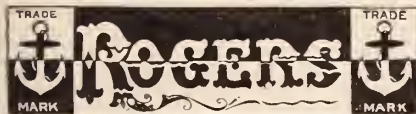

IS THE GENUINE.  
Manufactured by

**WM. ROGERS M'F'G CO.,**  
HARTFORD CONN.

**ALBERT BERGER & CO.**  
47 MAIDEN LANE, N. Y.  
Spectacles & Optical Goods;  
GROUND LENSES A SPECIALTY.

We sell to the legitimate Jewelry and Stationery trade only.



NEW YORK CITY, U.S.A.

**CHOICE PAPERS**

MAKERS OF

**FINE STATIONERY**

For Correspondence, Wedding and Business Use, handsomely boxed, specially suited to the Jewelry Trade.

18 MURRAY STREET, NEW YORK.]

# R. WALLACE & SONS MFG. CO.

## SILVERSMITHS,

WALLINGFORD, - - - - - CONN.



No. 20 CUTICLE KNIFE.



No. 20 CORN KNIFE.



No. 20 NAIL FILE.

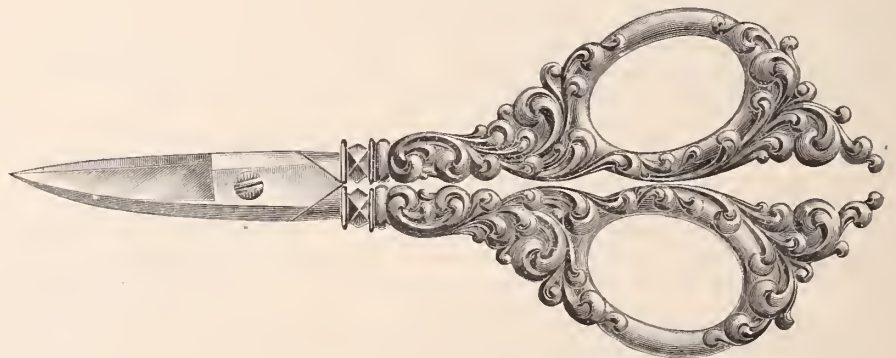

No. 20 NAIL SCISSORS.



No. 20 TWEEZERS.

NEW YORK  
226 FIFTH AVENUE.

SAN FRANCISCO  
120 SUTTER STREET.

CHICAGO  
86 WABASH AVENUE.

### The Shocking Death of Andrew H. Schilling.

SYRACUSE, N. Y., Nov. 6.—A fatality of unusual sadness in all its details occurred at the Delaware, Lackawanna & Western railroad station in this city at 5.30 o'clock, Saturday afternoon. While attempting to board a moving passenger train, Andrew H. Schilling, a prominent jeweler of Oswego, was thrown under the rear coach and instantly killed, the wheels passing over his neck and practically severing the head from the body.

Mr. Schilling came to Syracuse Saturday morning with his cousin. He had made arrangements with Joseph Seymour's Sons & Co. to go to work for them at an early date. An eye witness of the accident says that Mr. Schilling came rushing out of the station just as the train was moving away. He grabbed one of the hand guards on the front steps of the rear coach and at that moment the train gave a sudden jerk and Schilling was thrown directly under the wheels. The body was removed to Mullin's morgue in the dead wagon, a delegation from the Syracuse Lodge of Elks taking care of the remains.

Andrew H. Schilling was born in Oswego, 30 years ago and lived with his widowed mother and a sister, on the east side. He was employed in Wendell's jewelry store in Oswego for nine years. On the death of jeweler Fred Mongin, he bought Mr. Mongin's business and conducted it for

seven years, up to last July. He then sold out his business, having in view his connection with the Seymours, in this city. Mr. Schilling was soon to be married to Miss Carrie Mitchell, daughter of Edward Mitchell, ex-Mayor of Oswego.

### Government Proposals for Supplying Silver Plated Ware.

WASHINGTON, D. C., Nov. 8.—The War Department, through the Philadelphia Depot of the Quartermaster's Department, 1428 Arch St., is inviting proposals until Nov. 21, 1894, for a lot of table ware, among which are the following items:

One hundred and eighty-four dozen silver plated teaspoons, to be equal to Rogers' best triple plated silver plated ware, "Anchor" brand and "Windsor" pattern; plated on white metal, and to strip at least 10 1-2 dwts. of silver to each dozen. Length, 6 inches. To be indelibly marked on upper flat side of handle with the letters "Q. M. D.," and to be equal in every respect to the standard sample.

One hundred and fifty-seven dozen silver plated tablespoons, to be equal to Rogers' best triple plated silver ware, "Anchor" brand and "Windsor" pattern; plated on white metal and to strip at least 21 dwts. of silver to each dozen. Length, 8 1-16 inches. To be indelibly marked on upper flat side of handle with the letters "Q. M. D.," and to be equal in all respects to the standard sample.

72 dozen silver plated table forks to be equal to Rogers' best triple plated silver ware, "Anchor" brand and "Windsor" "Medium" pattern; plated on white metal, and to strip at least 21 dwts of silver to each dozen. Length, 7 10-16 inches. To be indelibly marked on handle with the letters "Q. M. D.," and to be equal in every respect to standard sample.

Two hundred and thirty-six dozen plated knives to be equal to Rogers' best triple plated silver ware, "Anchor" brand, "Medium" pattern, and square handles. Plated on steels, and to strip at least 12 dwts of silver to each dozen. Length, 9 3-16 inches. To be indelibly marked on handle with the letters "Q. M. D.," and to be equal in every respect to the standard sample.

One hundred and twenty-five dozen silver plated mustard spoons.

### War Against the Watch Club Schemes of the Pacific Coast.

LOS ANGELES, Cal., Nov. 7.—The Post Office authorities on this coast have taken decided action against watch clubs. They have notified a number of jewelry stores in this city who have been conducting these schemes that they are violating the law against using the mails for lottery purposes.

It is claimed that the prime cause for moving against this class of trade is that a number of unscrupulous adventurers hereabouts have been using the club plan in working up suit clubs and that in a number of instances the patrons have been swindled by the club breaking up before the last man got out; the postal authorities were asked not to allow the mails to be used for such purposes and they decided that in order to stop the suit club men they would have to stop all persons from working this kind of scheme, including the watch club jewelers.

# Jno. W. Reddall & Co

*A Stock more attractive than ever.*  
*Replete with new and artistic conceptions in fourteen karat gold.*

MAKERS OF THE MOST POPULAR LINE OF  
 SILVER MOUNTED BRACES AND BELTS.

107 HAMILTON STREET,  
 Newark, N. J.

# CARBORUNDUM.

## Net Retail Price List of Carborundum Wheels.

ACLESOR'S PATENT, February 28th, 1893.

Diam. in Inches	THICKNESS IN INCHES.																Rev. per Minute.	
	1/4	3/8	1/2	5/8	3/4	7/8	1	1 1/4	1 1/2	1 3/4	2	2 1/4	2 1/2	2 3/4	3	3 1/2		4
1	\$.15	\$.18	\$.20	\$.23	\$.25	\$.28	\$.30	\$.35	\$.40	\$.45	\$.50	\$.55	\$.61	\$.65	\$.70	\$.80	\$.90	18,000
1 1/2	.18	.22	.25	.28	.31	.33	.35	.40	.45	.50	.56	.62	.67	.73	.78	.90	1,000	14,000
2	.21	.25	.30	.34	.37	.40	.42	.46	.52	.58	.65	.70	.77	.85	.91	1.00	1,200	11,000
2 1/2	.25	.30	.37	.42	.46	.48	.50	.55	.60	.67	.75	.80	.91	.98	1.05	1.20	1,400	8,800
3	.30	.38	.45	.50	.55	.58	.60	.65	.70	.78	.85	.95	1.05	1.15	1.25	1.45	1,650	7,400
4	.35	.45	.55	.60	.65	.70	.75	.80	.90	1.00	1.10	1.20	1.30	1.40	1.55	1.70	2,000	5,500
5	.40	.50	.60	.70	.80	.90	1.00	1.10	1.20	1.30	1.40	1.50	1.65	1.80	2.00	2.15	2,350	4,400
6	.45	.55	.65	.75	.85	.95	1.05	1.15	1.25	1.35	1.45	1.55	1.70	1.85	2.05	2.20	2,450	3,700
7	.50	.60	.70	.80	.90	1.00	1.10	1.20	1.30	1.40	1.50	1.60	1.75	1.90	2.10	2.25	2,550	3,100
8	.55	.65	.75	.85	.95	1.05	1.15	1.25	1.35	1.45	1.55	1.65	1.80	1.95	2.15	2.30	2,650	2,750
9	.60	.70	.80	.90	1.00	1.10	1.20	1.30	1.40	1.50	1.60	1.70	1.85	2.00	2.20	2.35	2,750	2,450
10	.65	.75	.85	.95	1.05	1.15	1.25	1.35	1.45	1.55	1.65	1.75	1.90	2.05	2.25	2.40	2,850	2,200
12	.75	.85	.95	1.05	1.15	1.25	1.35	1.45	1.55	1.65	1.75	1.85	2.00	2.15	2.35	2.50	2,950	1,830

CARBORUNDUM was awarded both a Medal and a Diploma at the World's Columbian Exposition in recognition of its merits as an Abrasive, the hardness being greater than any other abrasive material.

The wheels are made with a vitrified bond, and pressed under hydraulic pressure. Those over three inches in diameter are turned up after firing. The same numbers are used to designate the degrees of fineness, as are used with Emery, and the wheels are made in seven degrees of hardness, marked SSS, SS, S, M, H, HH, HHH, from extremely soft to extremely hard.

In ordering, state diameter, thickness, hole, number and hardness.

Monongahela, Pa., U. S. A.

THE CARBORUNDUM COMPANY.

Hones, Slabs, Files.

Cut = This = Out.

**Paul Jeanne,** EIGHTEENTH STREET and 4<sup>TH</sup> AVE., N. Y.  
(Bradley Building.)

MANUFACTURER OF

≡ FINE ⊗ DIAMOND ⊗ JEWELRY. ≡

New Firm.

Latest Methods.

Best Results.

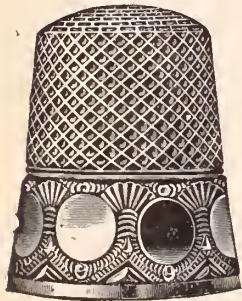

KETCHUM & McDOUGALL,  
MANUFACTURERS  
GOLD & SILVER THIMBLES,  
GOLD COLLAR BUTTONS,  
AUTOMATIC EYE-GLASS HOLDERS  
198 BROADWAY N. Y.



ILLUSTRATED CATALOGUE SENT ON APPLICATION

SEND US A TRIAL SHIPMENT

And Convince Yourself.

RESULTS TALK LOUDEST.

GUILD & GARDINER,

Assayers,

REFINERS AND SWEEP SMELTERS,

189 Eddy St., Providence, R.I.

THE IMPROVED RIVAL FOUNTAIN PEN. Most reliable and guaranteed to give perfect satisfaction. Over 75,000 in use.

Send for Price List and Liberal Discounts.



Export Trade Solicited.

D. W. BEAUMEL, 17 John St., N. Y., Inventor and Manufacturer. Repairing a Specialty. The Electric Stylographic Pen.



THE PHILADELPHIA COLLEGE OF HOROLOGY.

A practical school to learn watch-making, engraving, jewelry repairing and optics. One tuition pays for all branches. Send for prospectus.

F. W. SCHULER, Principal.

No. 623 HEED BUILDING, PHILADELPHIA, PA.

JOBBERS IN

IMPORTERS OF  
**DIAMONDS.**

Watches, Jewelry, Chains,  
NOVELTIES, ETC.

Latest Designs. Lowest Prices.

**AIKIN-LAMBERT  
JEWELRY CO.,**

19 Maiden Lane, New York.

CHICAGO BRANCH: 103 STATE ST.



**Notable Results in Railway Watch Examination.**

CHICAGO, ILL., NOV. 10.—In the examination of 1,236 watches on the C. & O., and the St. L. & S. F. Rys., but one watch was found to be unsafe for that hardest test of timekeeping quality—the railway service. This is the record presented by J. W. Forsinger, time inspector for the above railways in the reports recently rendered to the general superintendents. The summaries follow:

**CHESAPEAKE & OHIO RY.**

Watches inspected, . . . . .	843
Watches compared with standard time weekly, . . . . .	689
Average number of days run for rated watches, . . . . .	24
Average daily variation, in seconds, for rated watches, . . . . .	.7
Rejected as unsafe, . . . . .	1

**ST. LOUIS & SAN FRANCISCO RY.**

Watches examined, . . . . .	393
Watches compared weekly, . . . . .	342
Average number of days run for rated watches, . . . . .	46
Average daily variation in seconds for rated watches, . . . . .	.5

Competent inspectors who contributed to so favorable results include:

St. L. & S. F.—J. A. Droz, St. Louis, Mo.; Henry Seele, Newburg, Mo.; Wm. Brazeal, Pacific, Mo.; Frank Clark, Springfield, Mo.; J. L. Woolford, Monett, Mo.; M. T. Balsley, Joplin, Mo.; L. M. Smith, Pittsburg, Kan.; E. T. Tanquary, Neodesha, Kan.; H. W. Nunamaker, Ellsworth, Kan.; Klein & Fink, Fort Smith, Ark.; Noyes & Huber, Paris, Tex.; W. T. Danner, Burrton, Kan.; C. S. Poole, Anthony, Kan.

C. & O.—J. T. Allen & Co., Richmond, Va.; J. W. Lipop, Clifton Forge, Va.; Geo. A. Keller, Charlottesville, Va.; W. L. Fredeking & Co., Hiuton, W. Va.; Glenn Hilton, Huntington, W. Va.; F. Piepers, Covington, Ky.; Wm. Owen, Cincinnati, Ohio; J. Jones, Lexington, Ky.; I. N. Pollock, Ashland, Ky.

**Death of an Old-Time Jewelry Manufacturer.**

PAWTUCKET, R. I., NOV. 6.—Samuel G. Stiness was struck by a locomotive at the Broad St. crossing last evening and instantly killed. He endeavored to cross the tracks after the gates were down, but slipping, fell beneath the locomotive which mangled his body beyond recognition.

Samuel George Stiness was the son of the late Phillip Bessow Stiness and was a native of Smithfield, R. I., where he was born 65 years ago. At an early age he learned the jewelry business and for a few years previous to the breaking out of the war was a manufacturer of jewelry in Providence. He gave up this business in 1861 and enlisted and served as a dispatch bearer until he was disabled and compelled to leave the service.

The deceased was regarded as an eminent authority upon all matters bearing on gas or electric lighting. He was vice-president of the National Association of Gas Engineers. He occupied a high rank in Masonic circles and was a past presiding officer of the various branches of this fraternity.

**Another Daring Window Smashing Affair in Norristown, Pa.**

NORRISTOWN, Pa., NOV. 7.—Shortly after 5 o'clock yesterday evening a daring thief hurled a brick through the show window of Thad. S. Adle's jewelry store and snatching up a tray of rings, walked rapidly away, finally breaking into a run. Three men who saw the thief gave chase, but the fellow eluded them in the Reading Railroad freight yard, where a number of cars were standing.

The robbery was committed in the brilliantly lighted business center of the borough, while persons were passing the store. The plunder is valued at \$125. The damage to a number of articles struck by the missile will amount to as much more.

**The Jewelers' League.**

The regular monthly meeting of the executive committee of the Jewelers' League was held on Wednesday, Nov. 7th. There were present: President Hayes; Vice-Presidents Bowden and Greason; Messrs. Jeannot, Van Deventer, and L. Stevens,

**If You are In business For Profits**

You should sell the new

**"Princeton" Watch**

and not be obliged to compete with outsiders nor have your customers tell you prices.

**Three grades:**

16 size Nickel, Hunting and Open Face—15, 16 and 17 Jewels, Adjusted, Patent Regulator.

**Superior to any, and at less price.**

**Ask your Jobber.**

Price Lists with full information mailed to regular jewelers upon application.

**A. C. SMITH WATCH CO.,**  
Manufacturers,

177 BROADWAY, - NEW YORK.

ESTABLISHED 1843.

Highest Awards in Every Competition

**LEROY W. FAIRCHILD & Co.,**  
3 Maiden Lane, New York City,

**Gold Pens, Gold and Silver Pencils and Pen Cases,**

**The Handsomest and Cheapest Line of Goods in the Market.**

WORKS: 3D AVENUE AND OGDEN ST., NEWARK, N. J.

# GREAT BARGAIN!

**“A GOLD DOLLAR FOR ONLY 49 CENTS!”**

Such is the general character of the advertisements that take up the greatest space in the newspapers of the day, and the gulls flock in to buy the “great bargain,” but soon after, they discover it is only a BRASS IMITATION, a deception, a cheat, a fraud. Our attention was called the other day to the advertisement of a large dry goods house that they were selling

**ROGERS' TEA SPOONS ONLY 65 CENTS A SET.**

We sent and got a set which the glib saleslady said were “Rogers' BEST goods, warranted for five years,” and we analyzed them as follows:—

**The Pattern:**—An old discarded failure, of a concern that gave up the ghost of making flatware over ten years ago, coarse as to die work, and coarser in finish.

**The Plating:**—JUST ONE QUARTER the thickness of the genuine ★ Rogers & Bro. A 1, extra plate.

**The Metal:**—About one half the quality of the Nickel Silver used in the genuine Rogers & Bro., Star Brand Goods.

**The Stamp:**—A Bogus Rogers that never made a spoon in his life, and is not in the business except with his name.

**The warrant for five years:**—Would hardly cover five months.

**The Price:**—Less than half what the genuine brand ★ Rogers & Bro. A 1, can be retailed for by the honest dealer.

---

**Moral:**—Isn't the gold dollar for 100 cents the cheapest, and doesn't a man enjoy a good conscience when he sells it?

THE FLEMISH

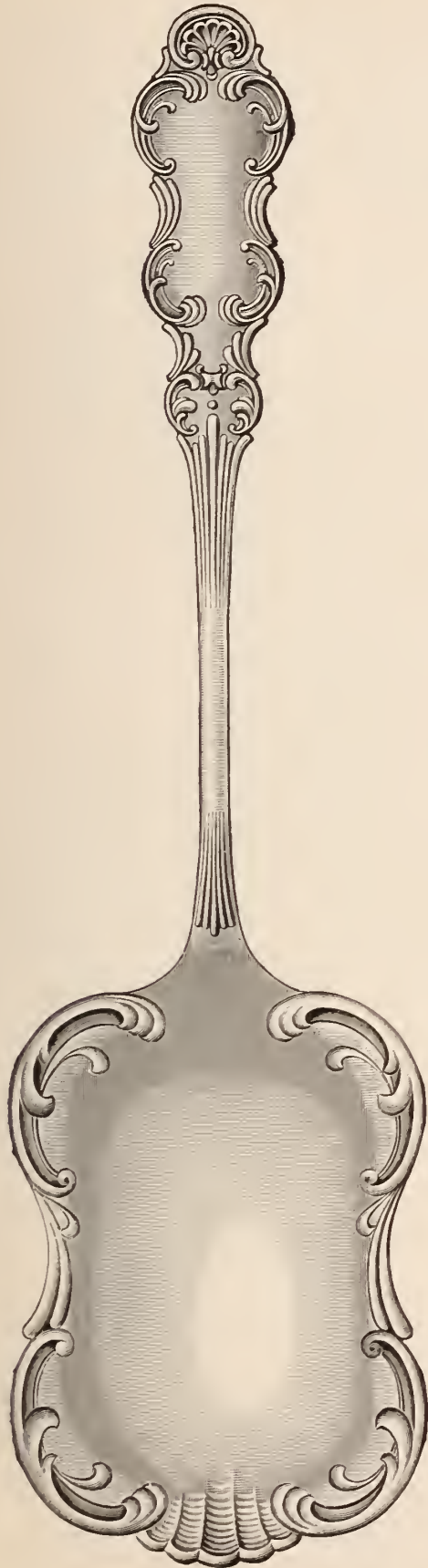

BERRY SPOON.

**The Genuine Rogers**  
**Electro Silver Plate**  
**Spoons, Forks, Knives, &c.**

**CAUTION!**

The name of **Rogers** is stamped on all sorts of **Electro Silver Plated Flatware**, some of it common and worthless. It is therefore necessary to **carefully examine** the **brand** in order to obtain the **right goods**.

THE ORIGINAL AND GENUINE  
**STAR ★ BRAND**

which has been made continuously for half a century, given perfect satisfaction and made the name of **Rogers** on Electro Silver Plate celebrated, is stamped

**★ ROGERS & BRO. A 1.**

If you want the genuine goods which will satisfy your customers, and build up your reputation as a reliable dealer buy those bearing the above trade mark.

For sale by the leading jobbers throughout the country, and manufactured exclusively by

**ROGERS & BROTHER,**

16 Cortlandt Street, N. Y. - - - - Waterbury, Conn.

The Oldest Makers of **ROGERS GOODS** in existence.

A Large Line of **FANCY PIECES** put up in beautiful **PLUSH LINED BOXES**, suitable for the **HOLIDAY TRADE, NOW READY.**

secretary. The minutes of the previous meeting were read and approved.

Six requests for change of beneficiary were received and granted and the following applicants were admitted to membership:

Section A.—C. H. Chaffee, New York city. Recommended by C. A. Starbuck and C. E. Leach.

Section A.—N. H. Davis, Worcester, Mass. Recommended by Geo. B. Osborn and Geo. W. Harlow.

Section A.—E. L. Gowen, Attleboro, Mass. Recommended by J. L. Sweet and C. L. Watson.

Section B.—H. N. Tuttle, Philadelphia, Pa. Recommended by H. G. Gill and F. B. Hurlburt.

The next meeting of the executive committee will be held on Friday, Dec. 7th.

**Imports and Exports for September, 1894, and the Preceding Nine Months.**

WASHINGTON, D. C., Nov. 10.—The summary statement of imports and exports for the month ending Sept. 30, 1894, and the nine months ending the same date, compared with the corresponding periods of 1893, has been issued, and contains the accompanying figures relative to the jewelry trade.

The comparative summary of values of merchandise imported and exported during the nine months ending Sept. 30, from 1889 to 1894, inclusive, shows the following amount the jewelry and kindred lines: Average of the preceding five periods, imports, clocks and watches and parts of, \$1,391,788, nine months ending Sept. 30, 1894, \$744,190; imports, jewelry, manufactures of gold and silver and precious stones, average of the five preceding periods, \$10,684,472; nine months ending Sept. 30, 1894, \$5,450,085; exports, clocks and watches, average of the five preceding periods, \$1,023,334; nine months ending Sept. 30, 1894, \$871,313.

	SEPTEMBER		AUGUST	NINE MONTHS ENDING SEPTEMBER.	
	1894.	1893.	1894.	1894.	1893.
<b>IMPORTS.</b>					
Diamonds and other precious stones, rough and uncut, including glaziers' and engravers' diamonds, not set, and jewels to be used in the manufacture of watches.	\$5 785	\$32 979	\$161 858	\$812 253	\$665 717
Clocks and parts of.	34 283	14 624	14 353	66 505	129 646
Watches, and parts of, and watch materials and movements.	86 706	99 312	69 664	677 625	1 139 962
Jewelry, and manufactures of gold and silver.	25 030	56 122	24 951	253 922	564 980
Precious stones, n. e. s. and imitations of, not set.	124 709	149 437	889 748	5 196 163	9 116 004
<b>EXPORTS.</b>					
Clocks, and parts of.	78 537	75 456	55 392	648 640	688 686
Watches, and parts of.	28 735	39 231	23 280	222 673	271 672
Jewelry, and manufactures of gold and silver.	48 679	66 583	53 524	545 936	797 942
Plated ware.	17 051	26 185	29 458	171 488	247 503
<b>EXPORTS OF FOREIGN MERCHANDISE.</b>					
Diamonds and other precious stones, rough and uncut, etc.				2 220	355
Clocks, and parts of.	52	30	60	318	654
Watches, and parts of, etc.	18	104	24	48 420	437
Jewelry, and manufactures of gold and silver.	1 196	3 495	29 891	49 297	10 981
Precious Stones, n. e. s. and imitations of, not set.	2 096			4 264	1 168



**REORGANIZATION SALE OF Opera and Field Glasses.**

We have for immediate sale the largest and best selected stock of Opera and Field Glasses in this country, and offer them at fully 25 per cent. below cost. A few specimen items:

- 75 Non-Achromatic Field Glasses**, 24 lines objective, in case, REGULAR PRICE, \$3.25, REDUCED TO..... **\$2.00**
- 50 Colmont Field Glasses**, 26 lines objective, in case, REGULAR PRICE, \$6.00, REDUCED TO..... **\$4.90**
- 85 Non-Achromatic Opera Glasses**, 15 lines objective, in case, REGULAR PRICE, \$9.00 per doz., REDUCED TO..... **\$5.25 per dozen**
- 50 Achromatic Opera Glasses**, leather covered and japanned, 15 lines objective, in case, REGULAR PRICE, \$1.75 each, REDUCED TO..... **\$1.35 each.**
- 50 Achromatic Opera Glasses**, leather covered and japanned, finer quality, 12 lines objective, in pocket book case, REGULAR PRICE, \$2.25 each, REDUCED TO..... **\$1.55 each.**
- 40 Achromatic Opera Glasses**, pearl covered, 15 lines objective, in case, REGULAR PRICE, \$3.75 each, REDUCED TO..... **\$2.90 each.**
- 36 Achromatic Opera Glasses**, pearl covered, 17 lines objective in case, REGULAR PRICE, \$4.50 each, REDUCED TO..... **\$3.70 each**

—SEND FOR SAMPLES.—

**QUEEN & CO., Opticians,**

1010 Chestnut St., Philadelphia.

J. G. GRAY, Assignee.

DON'T FORGET THE JEWELERS' CIRCULAR PUBLISHING CO.'S BOOK LIST when in want of any technical book in the Jewelry or Kindred Trades.

ESTABLISHED 1870.



TRADE MARK.

**SAMUEL C. JACKSON,**

MANUFACTURER OF

**FINE CASES FOR**

Jewelry, Silverware, &c., also Hardwood Chests, Trays, and Sample Cases.

**180 BROADWAY,**

**NEW YORK.**

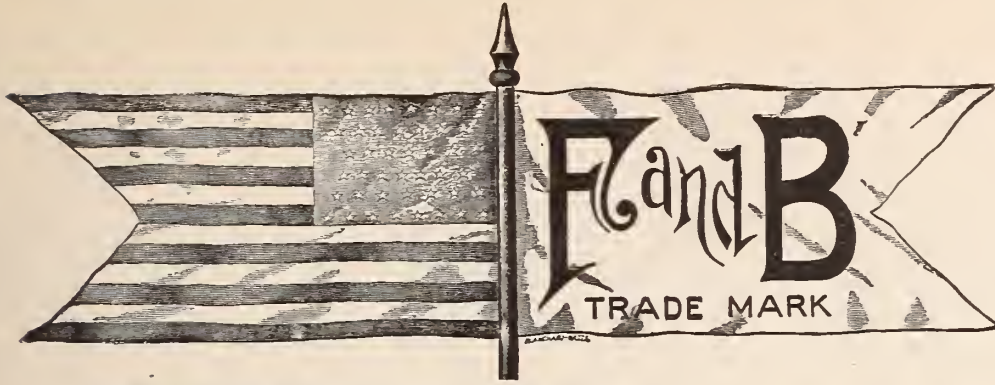

# FOSTER & BAILEY,

100 RICHMOND ST.,

PROVIDENCE, R. I.



ONE QUARTER SIZE.

Be sure and see the Manicure Goods that we have just put out. This cut shows a set in a nice box, lined with Chamois, and is a quarter size. Beautiful Goods. The steel parts are made by the famous Henckles, of Germany, and are considered the best in the world. We make the goods in Sterling Silver and also in Tenth Gold, and at such a low price! The goods are boxed just right, so that a traveler can carry them in a trunk, and take up but little room. Sets without the large tray and buffer box and others with less pieces at low prices.

No. 1, 2, 3 is Sterling Silver. No. 4, 5, 6 Tenth Gold. Every piece is numbered and can be ordered separate, and at prices that will sell the goods. We make a specialty of Sterling Silver Novelties, comprising

Match Boxes, Manicure Articles, Shoe Buttoners, Embroidery Scissors, Garters, Paper Cutters, Ladies' Seals, Etc. All  $\frac{925}{1000}$  Fine.

### Rolled Plate Watch Chains

Our Chains can be safely sold to the best trade, and guaranteed as superior quality. No chance of poor quality where chains are stamped F. & B.

### Gold Vest and Dickens Chain

Soldered with 10 K. Gold Solder. Will assay 1-10 Gold.

### Chain Mountings

We are headquarters, and make everything in this line.

### "Mount Hope" Buttons

Superior to any button in the world. Easy to put in and take out of the cuff.

### Solid Gold Locket

With Diamonds and without. This is a beautiful line and solid throughout.

### Link Buttons

We are making some very pretty styles in Roman, chased, engraved and plain, with and without stones, Sterling Silver and Rolled Plate.

### Locket and Charms

We make them in endless variety.

### Sterling Silver Goods

Match Boxes, Manicure Articles, Shoe Buttoners, Embroidery Scissors, Garters, Paper Cutters, Ladies' Seals, and various novelties, all  $\frac{925}{1000}$  fine.

### Bracelets

Curh Bracelets in all sizes, with padlocks and snaps, chased and plain polished, Roman, rolled silver plate and sterling silver. We make padlocks with keys and also with a push snap, which are very popular.

### Neck Chains and Lorgnette Chains

### Pins

Lace and Cuff Pins, with gold fronts, engraved also trimmed pins, Scarf Pins, Baby Pins with Chain. Also Baby Buttons with Chain. Sword Pins with Scabbard and Chain. Belt Pins.

### Glove Buttoners

### Crosses

Four sizes of gold filled in plain, engraved, and set with stones.

### Earrings

A nice line in engraved and trimmed. Eye Glass Chains in Gold and Plate. We received four awards and a medal at World's Fair.

secretary. The minutes of the previous meeting were read and approved.

Six requests for change of beneficiary were received and granted and the following applicants were admitted to membership:

Section A.—C. H. Chaffee, New York city. Recommended by C. A. Starbuck and C. E. Leach.

Section A.—N. H. Davis, Worcester, Mass. Recommended by Geo. B. Osborn and Geo. W. Harlow.

Section A.—E. L. Gowen, Attleboro, Mass. Recommended by J. L. Sweet and C. L. Watson.

Section B.—H. N. Tuttle, Philadelphia, Pa. Recommended by H. G. Gill and F. B. Hurlburt.

The next meeting of the executive committee will be held on Friday, Dec. 7th.

**Imports and Exports for September, 1894, and the Preceding Nine Months.**

WASHINGTON, D. C., Nov. 10.—The summary statement of imports and exports for the month ending Sept. 30, 1894, and the nine months ending the same date, compared with the corresponding periods of 1893, has been issued, and contains the accompanying figures relative to the jewelry trade.

The comparative summary of values of merchandise imported and exported during the nine months ending Sept. 30, from 1889 to 1894, inclusive, shows the following amount the jewelry and kindred lines: Average of the preceding five periods, imports, clocks and watches and parts of, \$1,391,788, nine months ending Sept. 30, 1894, \$744,190; imports, jewelry, manufactures of gold and silver and precious stones, average of the five preceding periods, \$10,684,472; nine months ending Sept. 30, 1894, \$5,450,085; exports, clocks and watches, average of the five preceding periods, \$1,023,334; nine months ending Sept. 30, 1894, \$871,313.

	SEPTEMBER		AUGUST	NINE MONTHS ENDING SEPTEMBER.	
	1894.	1893.	1894.	1894.	1893.
<b>IMPORTS.</b>					
Diamonds and other precious stones, rough and uncut, including glaziers' and engravers' diamonds, not set, and jewels to be used in the manufacture of watches.	\$5 785	\$32 979	\$161 858	\$812 253	\$665 717
Clocks and parts of.	34 283	14 624	14 353	66 565	129 646
Watches, and parts of, and watch materials and movements.	86 706	99 312	69 664	677 625	1 139 962
Jewelry, and manufactures of gold and silver.	25 030	56 122	24 951	253 922	564 980
Precious stones, n. e. s. and imitations of, not set.	124 709	149 437	889 748	5 196 163	9 116 004
<b>EXPORTS.</b>					
Clocks, and parts of.	78 537	75 456	55 392	648 640	688 686
Watches, and parts of.	28 735	39 231	23 280	222 673	271 672
Jewelry, and manufactures of gold and silver.	48 679	66 583	53 524	545 936	797 942
Plated ware.	17 051	26 185	29 458	171 488	247 503
<b>EXPORTS OF FOREIGN MERCHANDISE.</b>					
Diamonds and other precious stones, rough and uncut, etc.				2 220	355
Clocks, and parts of.	52	30	60	318	654
Watches, and parts of, etc.	18	104	24	48 420	437
Jewelry, and manufactures of gold and silver.	1 196	3 495	29 891	49 297	10 981
Precious Stones, n. e. s. and imitations of, not set.	2 096			4 264	1 168



**REORGANIZATION SALE OF Opera and Field Glasses.**

We have for immediate sale the largest and best selected stock of Opera and Field Glasses in this country, and offer them at fully 25 per cent. below cost. A few specimen items:

- 75 Non-Achromatic Field Glasses**, 24 lines objective, in case, REGULAR PRICE, \$3.25, REDUCED TO.....\$2.00
- 50 Colmont Field Glasses**, 26 lines objective, in case, REGULAR PRICE, \$6.00, REDUCED TO.....\$4.90
- 55 Non-Achromatic Opera Glasses**, 15 lines objective, in case, REGULAR PRICE, \$9.00 per doz., REDUCED TO.....\$5.25 per dozen
- 50 Achromatic Opera Glasses**, leather covered and japanned, 15 lines objective, in case, REGULAR PRICE, \$1.75 each, REDUCED TO.....\$1.35 each.
- 50 Achromatic Opera Glasses**, leather covered and japanned, finer quality, 12 lines objective, in pocket book case, REGULAR PRICE, \$2.25 each, REDUCED TO.....\$1.55 each.
- 40 Achromatic Opera Glasses**, pearl covered, 15 lines objective, in case, REGULAR PRICE, \$3.75 each, REDUCED TO.....\$2.90 each.
- 36 Achromatic Opera Glasses**, pearl covered, 17 lines objective in case, REGULAR PRICE, \$4.50 each, REDUCED TO.....\$3.70 each

—SEND FOR SAMPLES.—

**QUEEN & CO., Opticians,**

1010 Chestnut St., Philadelphia.

J. G. GRAY, Assignee.

DON'T FORGET THE JEWELERS' CIRCULAR PUBLISHING CO.'S BOOK LIST when in want of any technical book in the Jewelry or Kindred Trades.

ESTABLISHED 1870.



TRADE MARK.

**SAMUEL C. JACKSON,**

MANUFACTURER OF

**FINE CASES FOR**

Jewelry, Silverware, &c., also Hardwood Chests, Trays, and Sample Cases.

**180 BROADWAY,**

**NEW YORK.**

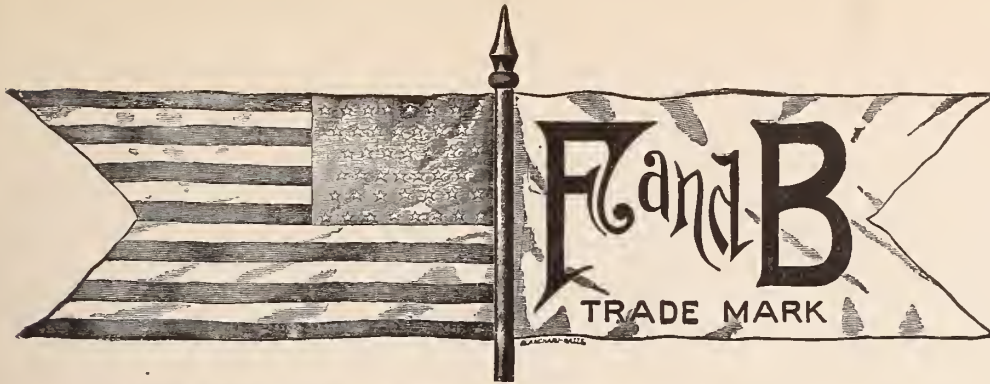

# FOSTER & BAILEY,

100 RICHMOND ST.,

PROVIDENCE, R. I.

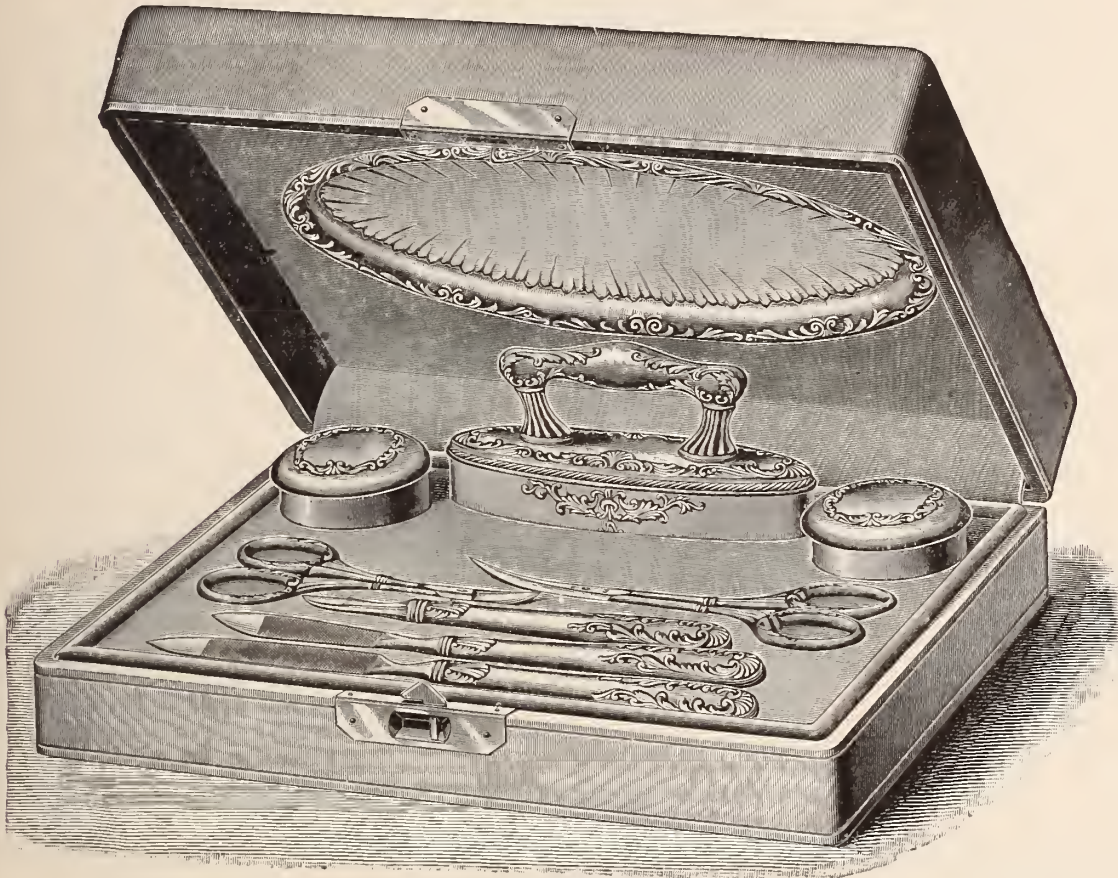

ONE QUARTER SIZE.

Be sure and see the Manicure Goods that we have just put out. This cut shows a set in a nice box, lined with Chamois, and is a quarter size. **Beautiful Goods.** The steel parts are made by the famous Henckles, of Germany, and are considered the best in the world. We make the goods in Sterling Silver and also in Tenth Gold, and at such a low price! The goods are boxed just right, so that a traveler can carry them in a trunk, and take up but little room. Sets without the large tray and buffer box and others with less pieces at low prices.

No. 1, 2, 3 is Sterling Silver. No. 4, 5, 6 Tenth Gold. Every piece is numbered and can be ordered separate, and at prices that will sell the goods. We make a specialty of Sterling Silver Novelties, comprising

Match Boxes, Manicure Articles, Shoe Buttoners, Embroidery Scissors, Garters, Paper Cutters, Ladies' Seals, Etc. All  $\frac{925}{1000}$  Fine.

#### Rolled Plate Watch Chains

Our Chains can be safely sold to the best trade, and guaranteed as superior quality. No chance of poor quality where chains are stamped F. & B.

#### Gold Vest and Dickens Chain

Soldered with 10 K. Gold Solder. Will assay 1-10 Gold.

#### Chain Mountings

We are headquarters, and make everything in this line.

#### "Mount Hope" Buttons

Superior to any button in the world. Easy to put in and take out of the cuff.

#### Solid Gold Locket

With Diamonds and without. This is a beautiful line and solid throughout.

#### Link Buttons

We are making some very pretty styles in Roman, chased, engraved and plain, with and without stones, Sterling Silver and Rolled Plate.

#### Locket and Charms

We make them in endless variety.

#### Sterling Silver Goods

Match Boxes, Manicure Articles, Shoe Buttoners, Embroidery Scissors, Garters, Paper Cutters, Ladies' Seals, and various novelties, all  $\frac{925}{1000}$  fine.

#### Bracelets

Curb Bracelets in all sizes, with padlocks and snaps, chased and plain polished, Roman, rolled silver plate and sterling silver. We make padlocks with keys and also with a push snap, which are very popular.

#### Neck Chains and Lorgnette Chains

#### Pins

Lace and Cuff Pins, with gold fronts, engraved; also trimmed pins, Scarf Pins. Baby Pins with Chain. Also Baby Buttons with Chain. Sword Pins with Scabbard and Chain. Belt Pins.

#### Glove Buttoners

#### Crosses

Four sizes of gold filled in plain, engraved, and set with stones.

#### Earrings

A nice line in engraved and trimmed. Eye Glass Chains in Gold and Plate. We received four awards and a medal at World's Fair.



# Perfect Construction

— AND —  
SUPERIOR FINISH

MAKE OUR PRODUCTIONS OF  
HIGHEST GRADE.

JEWELERS and  
FANCY GOODS DEALERS

will find in our new line of

## Art Metal Goods

many articles specially adapted  
to their trade.



### The Finest Line of Banquet Lamps

EVER PRODUCED.

Fitted with the Celebrated "B. & H." Burner.

New and Attractive Designs and Finishes. Sure to be Ready Sellers.

We will send you our Little Book, giving more information, if you desire, and will be glad to have you visit our Salesrooms and see the Goods.

## BRADLEY & HUBBARD MFG. CO.,

NEW YORK, PHILADELPHIA, BOSTON, CHICAGO,  
26 PARK PLACE 710 BETZ BLD'G. 160 CONGRESS ST. 204 MASONIC TEMPLE  
TO 21 BARCLAY ST. FACTORIES AND OFFICES, MERIDEN, CONN. ♣

## Now that we have touched bottom

And business generally is improving every GOOD RETAIL JEWELER should make his stock attractive and so invite customers. He can buy nothing more sure of sale than



1007

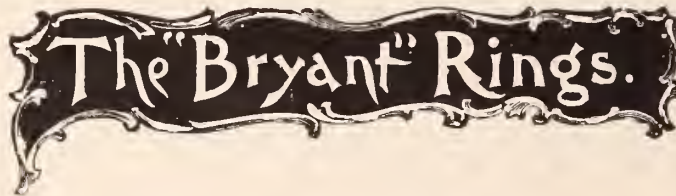

of standard quality, at moderate cost, and of new and taking styles. If not called upon by our travelers send your orders direct to

**M. B. BRYANT & CO.,**  
10 MAIDEN LANE, NEW YORK.

**WM. SMITH & CO.,**

Manufacturers of Gold, Silver and Roll Plate Chains and Jewelry.



Novelties in Gold and Silver Bead Necklaces and Bracelets. Also a large line of Chain Trimmings and Silver Rings.

Office: 5 and 7 Maiden Lane, New York. Factory: 61 Peck Street, Providence, R. I

### Richard Robinson & Co. Make an Assignment.

PROVIDENCE, R. I., Nov. 7.—Richard Robinson & Co., manufacturing jewelers, 227 Eddy St., made an assignment to Henry W. Harvey, of Harvey & Otis, Monday afternoon, which was recorded at City Hall shortly after 4 o'clock.

This concern commenced business Jan. 1, 1894, and consisted of Richard Robinson, P. H. Richards and Frank H. Purructer under the style of Richard Robinson & Co. They have done but a small business since starting, owing to the condition of the times.

Assignee Harvey stated that the only member of the firm was Richard Robinson and that the assignment was made simply because the firm had no money with which to continue. There have been no attachments placed upon the plant and there are no liens of any kind. Mr. Harvey will commence an immediate examination of the concern's affairs and expects to be able to give some idea of their standing the last of this week.

### A Clever Crook Proved Himself too Nery.

St. Louis, Mo., Nov. 8.—Chas. Wilson, a slick crook came to grief last Saturday through covetousness. Wilson went to the house of Mrs. Francis Molldring, 2,333 Pine St., and rented a down stairs room, paying \$1.50 for the first week's rent. He then went to the jewelry store of W. A. Gill, 616 Olive St., and selected a watch worth \$125. He told Mr. Gill to send the watch to 2,333 Pine St., to be examined by his mother, and if it suited her he would send the money back by the messenger. This was agreeable, and some time later Wm. Long was sent out to the house with the watch.

Wilson met Long at the door and conducted him to his room. Long handed him the watch and Wilson smilingly told him to take a seat and wait until he went upstairs to show the watch to his mother. Wilson said he would be back in a minute, but several minutes passed and no Wilson came. Finally, after waiting about half an hour, Long went upstairs and found Mrs. Molldring. He asked where her son was and Mrs. Molldring denied having a son. Explanations followed in rapid succession and a search resulted in the discovery that a window was up in the back parlor, showing how Wilson had escaped from the house.

Wilson was a nery crook and his nerve led him back to the vicinity of the house. Mrs. Molldring went to a butcher shop about 5 o'clock and one of the first persons she met was Wilson. She notified an officer and Wilson was placed under arrest. He confessed everything and the watch was recovered.

J. L. Seivert, Fulton, Mo., has been succeeded by J. Wolz & Son.



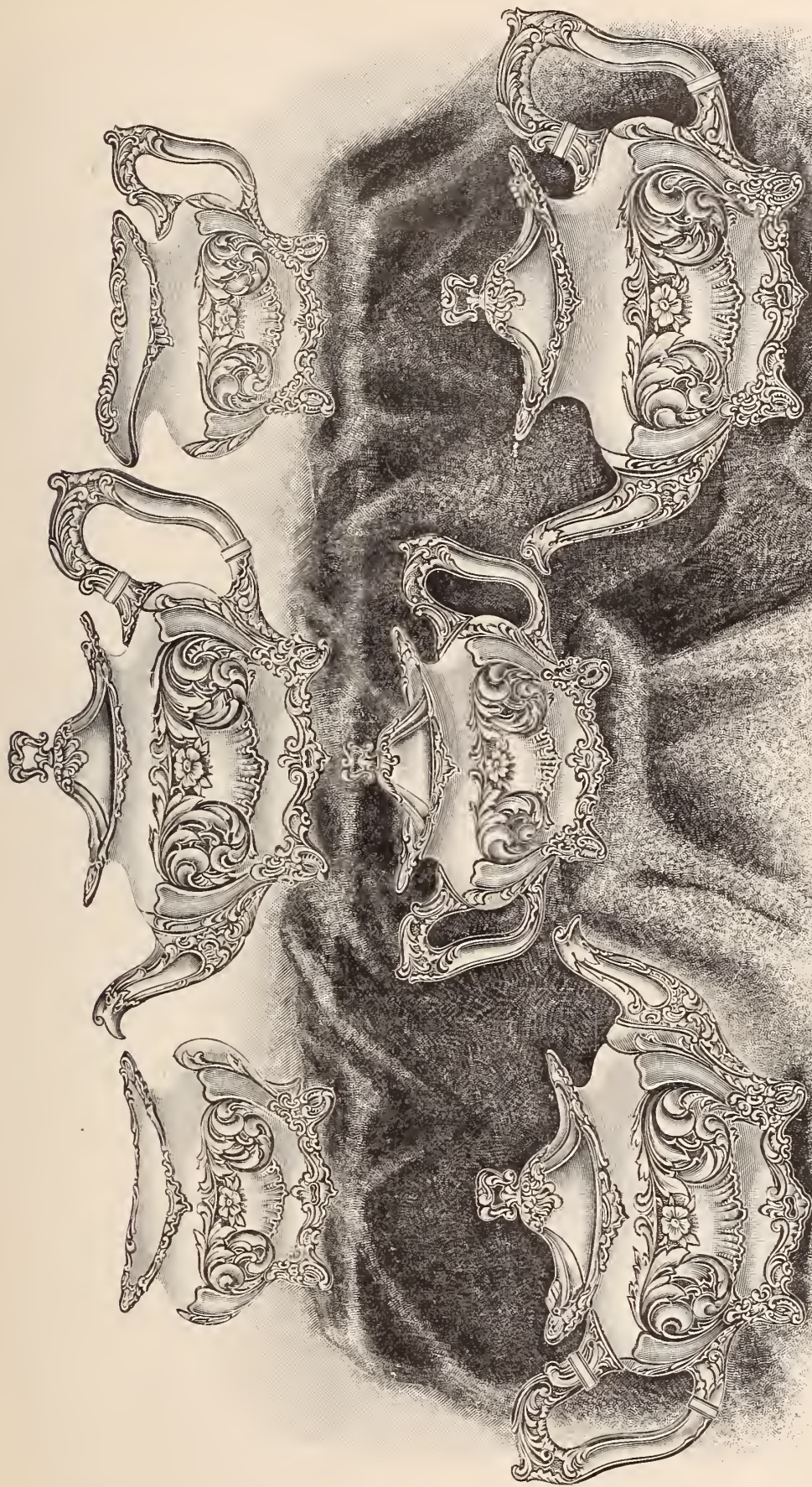

No. 1716 Embossed Tea Set. Butter, Syrup, Spoon Holder and Kettle to match.

We claim that the above cut represents *the most elegant set ever made in white metal.* We are making more elegant designs than ever. *Only the Best Quality of Plated Ware is cheap at any price.*

# THE MIDDLETOWN PLATE COMPANY,

22 John Street, New York.  
120 Sutter Street, San Francisco, Cal.

Middletown, Conn.

115 State Street, Chicago, Ills.



**The J. Ashton Jewelry Co. Comes to Grief and Disappears.**

ST. LOUIS, Mo., Nov. 7.—Three weeks ago two men rented the building formerly occupied by the Boatman's Saving Bank in 2d St., and set up the alleged banking firm of J. Otis Stevens & Co. Simultaneously the J. Ashton Jewelry Co. opened business at 9 S. 4th St. The partners of J. Otis Stevens & Co. were said to be Colonel "Bill" Traylor, Oscar St. Clair, formerly manager of the Hotel Vermont, in Chicago, and two silent partners, who were formerly connected with the Washington track. It was known that Oscar St. Clair, alias LeClaire, was both the manager of the jewelry concern and of the banking concern.

A representative of the jewelry company made an unsuccessful effort to effect large purchases in New York, as duly reported at length in THE CIRCULAR, using the fictitious bank's name. The bank likewise tried to purchase expensive office fixtures here, naming the jewelry firm as a backer and debtor. Saturday night all those concerned left the city, leaving their stenographers and other employes unpaid. St. Clair and Ashton are said to have operated a similar scheme in New Orleans and Chicago. It is not known how much money they took out of St. Louis.

There seem to have been four people interested as principals in the clever game planned by the schemers. Three of them

came to St. Louis some weeks ago; the other arrived within the last few days. The gentleman who has played the most prominent part thus far in the enterprise is O. C. St. Clair, alias Oliver Le Clare. His able lieutenant is Joseph Schwartz, alias "Diamond Joe Schwartz," alias "Frosty Joe," clerk and confidential adviser of the prospective jewelry establishment of John C. Ashton & Co. The third and the most modest of the quartet is John C. Ashton, alias "John Hadley," head of the firm of John C. Ashton & Co. And the fourth is the incomparable Bill Traylor, alias "Colonel William Traylor of Dinwiddle, Va.," alias "Mr. Evans, of Denver, Colo.," alias "Lord Ashcroft, of England," who arrived in the city last Thursday morning for the presumable purpose of playing the role of "J. Otis Stevens."

Besides these were countless "agents," men of good address, traveling in various parts of the country, who were to handle the bank's certificates; and in the prospective a horde of unsuspecting "suckers."

DIAMOND JOE SCHWARTZ' OPERATIONS IN CINCINNATI.

CINCINNATI, O., Nov. 8.—The exposure in St. Louis of the crooked operations of Colonel Bill Traylor, Diamond Joe Schwartz, Jack Ashton and a few others of the now-you-see-me-now-you-don't gang recalls the similar operations in this city of the firm of A. L. Dent & Co., just about a year ago.

# Scissors.

STERLING SILVER  
Scent Bottles,  
Manicure Articles.

## Novelties

IN LARGE VARIETY.

BACHRACH & FREEDMAN,  
SILVERSMITHS,

1 & 3 Union Square,

NEW YORK.



Trade Mark.

CHICAGO :  
800 Masonic Temple.

SAN FRANCISCO ;  
230 Kearney Street.

WRITE FOR ILLUSTRATED CATALOGUE.



### ELECTRIC TELEPHONE

Sold outright, no rent, no royalty. Adapted to City, Village or Country. Needed in every home, shop, store and office. Greatest convenience and best seller on earth.  
**Agents make from \$5 to \$50 per day.**  
One in a residence means a sale to all the neighbors. Fine instruments, no toys, works anywhere, any distance. Complete, ready for use when shipped. Can be put up by any one, never out of order, no repairing, lasts a life time. Warranted. A money maker. Write W. P. Harrison & Co., Clerk 10, Columbus, O.

OUR LINE OF

SILVER MOUNTED

## Ebony : Goods

Is the most artistic that has ever been shown.

We have produced the most elaborate line of Toilet and Manicure Articles on the market. These goods are mounted with Pierced Sterling Silver, artistically engraved. Also a line of Sterling Silver Pocket and Paper Knives, Scissors, Pen Wipers, Hair Pins, Filigree Coffee and Tea Spoons, Key Rings, Garter and Belt Buckles, Baby Rattles, Ink Stands, Curling Sets, Paper Files, &c. Also great variety of

Silver Mounted Pipes, Sterling Silver Scissors and Knives at low prices.

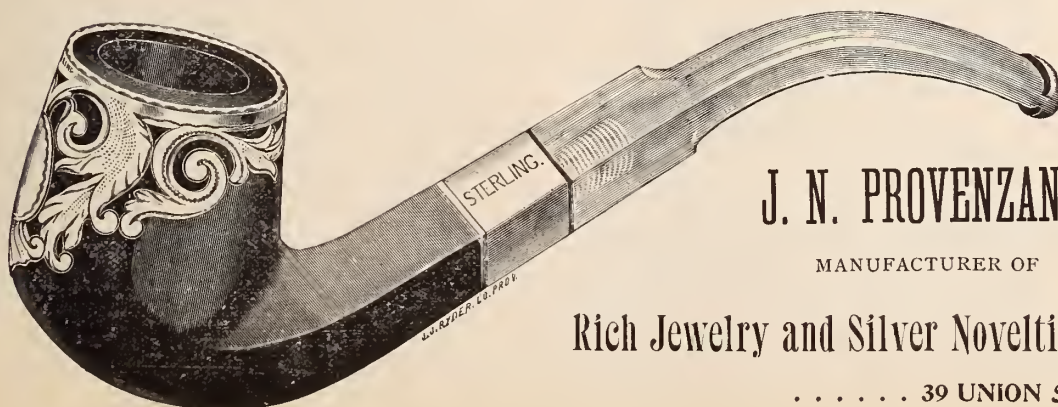
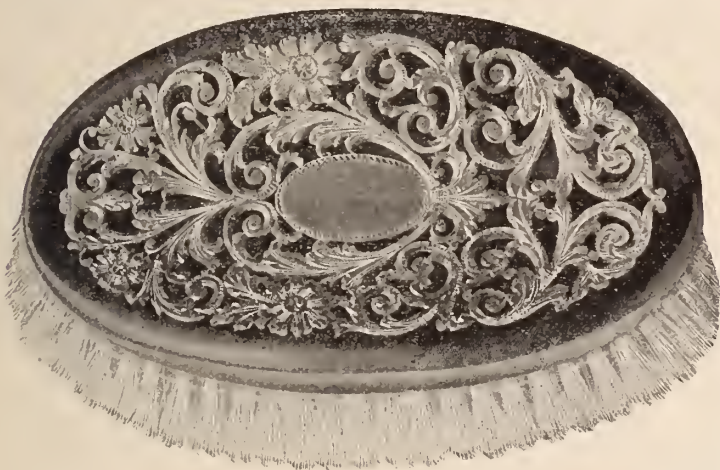

J. N. PROVENZANO,

MANUFACTURER OF

Rich Jewelry and Silver Novelties,

..... 39 UNION SQUARE, NEW YORK.

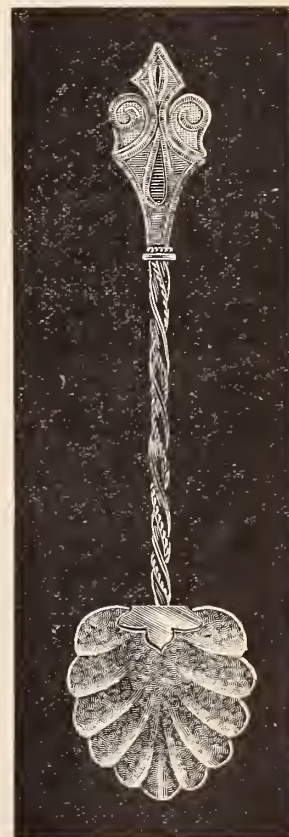

Schwartz was the head and tail of the operative department of the firm, and before his exposure sought to engage for his use the money of a number of acquaintances he made while here. The firm occupied quarters on the second floor of the Sinton building, corner of 5th and Vine Sts. and its operations in the business world consisted of trying to raise money on bogus diamonds.

An attempt to secure \$500 from Dr. De Johns, the dentist, upon some diamonds said to be worth \$1,800, but really not worth the cost of grinding the glass from which they were made, resulted in an exposure which helped Schwartz on in his decision to leave town. One Prof. Cham Ball, alias Bert Reese, a supposed accomplice of the man Schwartz, sniffed hostile air and also shook the dust of the city from his feet. The firm came to grief in a short time here and suspended operations for a continuation in more profitable fields.

#### Geo. W. Wells Discusses the Optical Business with Gov. Greenhalge.

BOSTON, Mass., Nov. 10.—To the statement made by Hon. George Fred. Williams that the American Optical Co.'s products were only affected by a 5 per cent. reduction, Gov. Greenhalge replies by pointing to the following tariff provisions on spectacles and lenses:

"Spectacles, eyeglasses, goggles, opera glasses and other optical instruments and

frames for the same, 40 per cent. ad. valorem. Wilson bill rate 35 per cent. Mills bill rate 40 per cent."

"Lenses of glass or pebble, wholly or partly manufactured, 35 per cent. ad valorem. Wilson bill rate 35 per cent. Mills bill rate 40 per cent."

His excellency received the following letter from George W. Wells, president of the American Optical Co:

Hon. Frederick T. Greenhalge.

DEAR SIR.—I understand that representations or misrepresentations are being made with regard to our business as compared with two years ago. However this may be the facts are that, taking 1892 as a basis, which was our most prosperous year, our sale fell off 14 per cent. in 1893 and our pay roll to \$47,000. Our sales in 1894 show a greater shrinkage than those of 1893, as compared with the previous year, and the pay roll in the same proportion. The average of help employed in 1893 and 1894 to the present day is 100 less than in 1892. We believe that all this was caused by the agitation of the tariff question, and we are also convinced that we have not yet experienced the full harmful effects of the serious changes of the schedules on our goods.

"From personal conversation with manufacturers in England, France and Germany the past Summer I am convinced that serious inroads are to be made by the importation of foreign-made goods in our line. The manufacturers and those interested, frankly stated that they were only waiting for the favorable changes in the tariff to enable them to ship large quantities of spectacles and eyeglasses to the States which was prevented by the McKinley bill. This can have but one effect, and that is to reduce the wages paid to American workmen on these goods, and I believe it will bring no corresponding advantage to the consumer.

"When I first came to Southbridge, I was one of 11 or 12 hands employed in this business. At the present

time, when business is at its normal condition there are over 1,000 hands employed in this town, and there never was a time when so good an article could be purchased for so small a price by the consumer as at present.

(Signed.)

GEO. W. WELLS.

#### Diamond Workers in Amsterdam on Strike.

On Thursday a prominent diamond cutting firm informed a CIRCULAR reporter that they had received advices from their representative in Amsterdam that a general strike of the diamond workers in Amsterdam occurred that day. The next day the following United Press dispatch appeared in some daily newspapers:

AMSTERDAM, Nov. 8.—More than 8,000 diamond workers struck here to-day for higher wages and 80 factories are closed. The employers will yield probably if the strikers hold out, but eventually will remove their business to another city, owing to their repeated difficulties with the men in this district.

The firm above referred to say that the boom in the diamond cutting industry in this country offers opportunity to as many striking workers to obtain good wages on this side of the Atlantic as desire to accept it.

#### Worked Many Philadelphia Jewelers With Bogus Checks.

PHILADELPHIA, Pa., Nov. 12.—William H. Hansell, of Fern Rock, Pa., was arrested here Wednesday evening last on the charge of obtaining goods by means of worthless checks. The warrant for his arrest was sworn out by jeweler George W. Russell, 22 S. 6th St., who alleged that Hansell got four unset diamonds valued at \$532 from him on a bogus check. At a hearing before Magistrate Mulligan the following day an avalanche of charges were made against Hansell by jewelers. He was accused with securing \$287 worth of diamonds from Westcott Bailey; \$1,025.62 worth of goods from H. Muhr's Sons; \$500 worth from Bailey, Banks & Biddle; \$250 worth from James Burdick; \$750 worth from Simons, Bro. & Co.; and diamonds valued at various other sums from S. W. & S. M. Friedenburgh, Kiefer & Deschamps, Kirchner & Son, and M. Kleckner.

The accused was held in \$3,000 bail, but a surprise developed later in the afternoon. Hansell's counsel appeared before the magistrate and expressed the belief that his client was of unsound mind. It was shown that two of his family had been insane, and on the promise of his friends that they would take care of him, Hansell was released from custody. In every case he had obtained the diamonds and jewelry on the presentation of checks which were dishonored.

The Ostby & Barton Co., Providence, are driven to their fullest capacity with orders and are working nights in order to supply the demand.

# NOVELTIES

IN

ROYAL WORCESTER,  
COALPORT, MINTON,  
POINTON, DOULTON,  
CROWN DERBY, Etc.

FRENCH FANCY GOODS, REAL AND IMITATION BRONZES,  
CLOCKS, PEDESTALS, ETC., ETC.

GILT REGULATORS

With Plain, Pierced, Pearl and Rhine Stone Dials.

THE CHOICEST LINE IN THE COUNTRY.

## LE BOUTILLIER & CO.,

860 BROADWAY,

Northeast Corner of 17th Street,

NEW YORK.

**Letters to The Editor.**

(It is THE CIRCULAR'S policy to publish letters addressed to the editor but it does not follow that he endorses the opinions expressed in them).

JEWELRY AND DEPARTMENT STORES.

ALBANY, N. Y., Nov. 10, 1894.

EDITOR OF THE JEWELERS' CIRCULAR:— Will you kindly permit me to take exception to your article "Jewelry and Department Stores" in your edition of Nov. 7th referring to the Providence Association. Your correspondent, upon whose information the article in question was based, has been misinformed. If I mistake not he interviewed me, and among the lesser evils I placed the department store as far as Providence was concerned. The Providence Association was not organized for the purpose of alone combatting the evil of manufacturers selling to department stores; although that is one of the evils organization has to contend with.

The Association was formed for the purpose of combatting the evil of manufacturers retailing; an evil that has almost wrecked the business of the retail jeweler, and that causes more injury to the retail trade than that of department stores combined. In no other place I have visited have I seen so little regard paid to the retail jeweler by the manufacturer, as in the city of Providence.

They, (the manufacturers), "pooh-pooh at the movement" as your article say they do, but let me assure them that there is an old adage they would do well to heed: "They laugh best who laugh last."

The Providence manufacturer is not dependent upon the trade of the Providence retailer, and he may laugh at the efforts these men make to protect their business from the greed of the manufacturer. Let them bear in mind that Newton Dexter when he tells the Providence retailer that there is a remedy for the evil of manufacturers retailing, is not making an empty boast. There are retailers in this country and their name is legion who stand ready to assist the Providence retailer. They are the men that the Providence manufacturer sells his goods to. I'll guarantee if THE CIRCULAR will furnish the names of those manufacturers who "pooh-pooh at this movement" that in six months the retail trade will see the shutters are placed upon the windows of their factories. Now that the manufacturers have thrown down the glove, in the name of the jewelers of Providence I'll pick it up.

As to the subject of the manufacturer selling the department stores I thoroughly agree in your opinion. Some years I had the honor of leading the retail drug trade of the country against a certain patent medicine manufacturer who catered for the trade of the dry goods store. When it reached the point that not a great gross of a certain medicine had been sold in three months between Chicago and the Pacific coast, the manufacturer was ready to call a halt. To-day some of those manufacturers are between the devil and the deep sea;

they can't sell the dry goods stores, nor can they sell the druggists. Out of the 40,000 retail druggists it can safely be said that 35,000 put up sarsaparilla under their own name. That crusade gave a boom to what is known as "Non-Secret Houses" that the manufacturer will never recover from.

The reputation that manufacturers' goods enjoy to-day was made by the retailer of jewelry and not dry goods stores, and I am inclined to believe the retailer still has it in his power to unmake, at the present time, as well as to make the reputation of the goods of any manufacturer, notwithstanding the "pooh-pooh" of the Providence manufacturer.—Very truly yours,  
NEWTON DEXTER.

**The Jewelers' Security Alliance.**

The regular monthly meeting of the executive committee of the Jewelers' Security Alliance was held at the Alliance office on the 9th inst. There were present: H. H. Butts, chairman; A. K. Sloan, president; J. B. Bowden, vice-president; Bernard Karsch, treasurer; Messrs. White and Wood, and Geo. H. Hodenpyl, secretary.

The following were admitted to membership: H. W. Carroll, Bennettsville, S. C.; Jules Renaud & Son, Keokuk, Ia.; Fred'k B. Morse, Cortland, N. Y.; Waltham Jewelry Co., Waltham, Mass.; Carl L. Rost, Crawfordsville, Ind.; Watson, Newell & Co., Attleboro, Mass.; H. E. Adams, Sanford, Fla.

A well-known optical house in Maiden Lane recently received an order from a western dealer for a pair of gold spectacles.

A pair sent with the order as sample in regard to size, etc., was a No. 2 eye. Not having a No. 2 eye spectacle frame in stock, the firm informed the westerner of this fact, stating they would send him a three eye spectacle unless otherwise advised. They received a letter countermanding the order, the dealer saying he had no use for three eye spectacles, as none of his customers had more than two eyes.

**THE FLETCHER PATENT  
Wall Case Tray System**

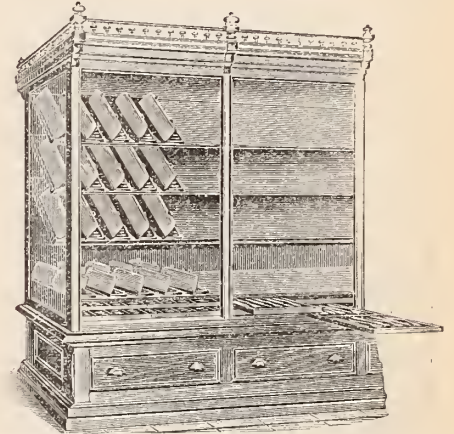

Complete line of goods displayed in Trays in one movement. Will increase carrying capacity one hundred per cent. Samples being shown in boxes on the shelves.

**FLETCHER MFG. CO.,**  
259 WEST 27th ST., NEW YORK.

New Creations this Season. Send for Catalogue.

**CHRYSO-CERAMICS, GOLD COVERED PORCELAIN.**  
**M. & E. HEALEY,**  
1122 CONNECTICUT AVE., WASHINGTON, D. C.  
MEDAL AT WORLD'S COLUMBIAN EXPOSITION.

A BEAUTIFUL AND ACCEPTABLE HOLIDAY PRESENT

**THE REGINA MUSIC BOX**

PLAYS ALL THE LATEST SONGS.

New tunes issued every week. Over one thousand are now ready including dances, operatic and all the popular airs of the day.

It is a musical novelty rendering on one or two accurately tuned steel combs the most beautiful music and playing an unlimited number of tunes.

It is the first and only music box manufactured in the United States and far surpasses the finest imported ones. The mechanism is of wonderful perfection and so strong and well finished that with ordinary care it will last for a life time. It runs fifteen minutes with one winding. All its parts are interchangeable. The cases are ornamental and highly polished. The tune-sheets are indestructible, being made of metal and are easily adjusted or changed. Send for illustrated catalogue.

**A. WOLFF,**  
194 Broadway, New York.

### The Death of Charles Constant Cottier.

A sad event last week was the death of Charles Constant Cottier, which occurred Nov. 7 at his late residence, 12 Congress



CHARLES CONSTANT COTTIER.

St., Jersey City, N. J. Mr. Cottier was the founder and senior member of the well known precious stone importing firm of C. Cottier & Son, and was generally considered

to be the foremost lapidary of his day. His death, which was due to old age and general debility, was not unexpected. Though severely ill but about one week, he had been ailing since his stroke of paralysis, 12 years ago.

Charles Constant Cottier was born in Gex, France, April 5, 1810. He started in the business which was destined to become the vocation of his life, when but a lad of 12 years. After serving his apprenticeship as a lapidary he continued in this work in his native village until his 20th year. Going to Paris he was employed by the then celebrated lapidary, David, now David Fières, and made Paris his home during his remaining years in France.

It was in 1840 that Mr. Cottier sailed to this country and immediately afterward established himself in business as a lapidary in Dey St., New York. Being one of the first, if not the only lapidary in the city, Mr. Cottier's business prospered and the year following he moved to 8 Cortlandt St., and shortly afterward commenced importing precious stones, being the second precious stone importer of New York, the first being Victor Bishop & Co. After occupying other locations in Cortlandt St., Mr. Cottier in 1857 moved to 171 Broadway, where his business remained until last May, when it changed to 14 Maiden Lane. In 1873 Mr. Cottier admitted his son, Jean J. C. Cottier, as a partner and changed the firm name to C. Cottier & Son.

Though widely known as an importer, Mr. Cottier was perhaps more famed throughout this country and Europe as a lapidary. He was the inventor of the

"Lake George" and "Star" cuts, which he brought out in the '70s, and which were used almost universally until about three years ago. He was also the recipient of a certificate of award for lapidary work exhibited at the Centennial Exposition at Philadelphia. Though naturally of a jovial and sociable disposition, Mr. Cottier never joined any societies, fraternities or benefit organizations, not even those in the jewelry trade. His only hobby outside his business was farming and to ride this he purchased and for many years operated a farm in Pike County, Pa., where he devoted his leisure time to experimenting.

It was here, in 1882 that Mr. Cottier received the paralytic stroke which practically forced his retirement from business and from work. Since then the business has been in charge of his son Jean, who now continues it under the old name. Mr. Cottier was married in 1843. His widow, son and a married daughter survive him.

The funeral services which were held Saturday morning at the Church of St. Paul and the Cross, Hancock Ave., Jersey City, were largely attended. The remains were interred at the family plot in Calvary Cemetery, Brooklyn.

Harris & Shafer are making improvements in their jewelry store at 1113 Pennsylvania Ave. N. W., Washington, D. C. So advantageous had the former venture proved that they are again adding more of the Fletcher patent system of trays, manufactured by the Fletcher Mfg. Co., 259 W. 27th St., New York.

# Great Sacrifice Watch Sale.

A RARE OPPORTUNITY TO BUY FINE WATCHES

BELOW THE PRICE OF ORDINARY.

Having decided to discontinue the "Complete Watch" branch of our business and to hereafter confine our trade exclusively to watch movements, we offer our large and superb stock of Paillard Non-Magnetic Ladies' and Gentlemen's Fine Gold Watches, Plain and Complicated, at prices less than manufacturing cost. These watches are high class and carry with them our full warrant and guarantee.

This entire stock must be closed out, regardless of cost, before January 1st, to make room for regular movements. If you have a trade in Fine Watches, or appreciate high class goods, or if you have a customer to whom you can sell a Fine Watch, this is the greatest opportunity ever offered and

ONE YOU SHOULD TAKE ADVANTAGE OF.

Selection Packages sent to responsible dealers. Parties unknown to us will please furnish New York references. Descriptive "Sacrifice Sale" Circular mailed upon application.

A. C. SMITH WATCH CO., 177 Broadway, New York.

# The Jewelers' Circular

AND  
HOROLOGICAL REVIEW.

PUBLISHED EVERY WEDNESDAY BY

THE JEWELERS' CIRCULAR PUB'G CO.,

189 BROADWAY, NEW YORK CITY

A JOURNAL DEVOTED TO THE INTERESTS OF JEWELERS, WATCHMAKERS, SILVERSMITHS, ELECTRO-PLATE MANUFACTURERS, AND ALL ENGAGED IN KINDRED BRANCHES OF INDUSTRY.

Our Editorial columns will contain our own opinions only, and we shall present in other columns only what we consider of interest or value to our readers. Advertising matter will not be printed as news.

Advertising rates in THE CIRCULAR are lower, considering the number of tradesmen reached by its large circulation, than in any other jewelry journal.

Notices of changes in standing advertisements must be received one week in advance; new matter can be received up to Monday.

## INFORMATION FOR SUBSCRIBERS.

### Terms of Subscription, Postage Prepaid.

	PER ANNUM
United States and Canada, . . .	\$2.00
Foreign Countries in Postal Union, . . .	4.00
Single Copies, . . . . .	.10

New subscribers can commence at any time.

Payments for THE CIRCULAR, when sent by mail, should be made in a Post-Office Money Order, Bank Check or Draft, or an Express Money Order or Registered Letter. All postmasters are required to register letters whenever requested to do so.

Pay money only to authorized collectors having proper credentials.

Returning your paper will not enable us to discontinue it, as we cannot find your name on our books unless your address is given.

In changing address always give the old as well as new one. Your name cannot be found on our books unless this is done.

We will continue to send papers until there is a specific order to stop, in connection with which all arrearages must be paid; but such an order can be given at any time, to take effect at the expiration of the subscription. All such orders will be promptly acknowledged by mail.

The Courts have decided that all subscribers to journals are responsible until arrearages are paid in full and an order to discontinue has been received by the publisher.

Member of the American Trade Press Association

VOL. XXIX. Nov. 14, 1894. No. 16.

WERE any signs wanting to tell us that the holiday season is coming, the numerous robberies throughout the country as reported in the news columns of THE CIRCULAR would prove all-sufficient.

THE official examinations of the watches of railroad employes are showing, as they follow each other, a more and more perfect quality of timekeepers in general use among these persons. In the latest tests of 1,236 watches of the Chesapeake & Ohio and St. Louis & San Francisco railroads but one watch was found to be unsafe.

THE Government Print has spells of erraticalness in the issuing of the *Official Patent Gazette*. The past few weeks have been one of them. For a fortnight no edition appeared, and then within two days, two editions overwhelmed us in rapid succession. Hence the latest patents in this number of THE CIRCULAR comprise the issues of Oct. 30 and Nov. 6.

### Pearls to be The Fashion

IF the dictates of the leaders of fashion in Paris are of any account, the pearl will be among the most fashionable of all ornaments this Winter. Strings of fine pearls will be twisted in and out among the coils of the hair, a happy revival of the styles in vogue in the days of Louis Quinze, when the ladies of France wore their hair powdered and decked with pearls. The use of pearls will not be confined to the hair, however, for they will be worn in every kind of necklace, from a single row to a wide collar made of rows of pearls caught together with a diamond clasp at intervals around the neck. A long, slender chain of pearls is another fancy, and this is worn twice around the throat, forming a kind of necklace. It falls in graceful loops to the waist, and is caught at one side of the corsage by a jeweled pin. For those who cannot afford the genuine article, there are surprisingly good reproductions of the most costly pearls.

### The Industrial Use of Aluminum.

FROM time to time this journal has taken occasion to consider the results of tests in the use of "the coming metal," aluminum, in various fields of industrial enterprise. By the promulgation of these results, aluminum as a competitor of silver, nickel and other metals employed in the arts may be readily valued by those who take an interest in the matter. The latest experiments with aluminum were the trials on the Thames River of a small torpedo boat, built with a steel framework and aluminum plates for the hull, which showed an unusual speed, which the makers state is partly owing to the use of the light metal and partly to the better balancing of the machinery, as well as the use of water tube boilers in place of the usual locomotive type. This and other tests reported from time to time, would lead to the belief that this metal may before long take an important place as a shipbuilding material, but they are offset by the recent tests made at the Norfolk navy yard in Virginia, where plates of pure aluminum and an aluminum-copper alloy were submerged in salt water for a considerable period, with very unfavorable results. Both the pure metal and the alloy were badly corroded and covered with barnacles. In the report submitted to the Navy Department it was stated as the opinion of the officers making the test that aluminum or such alloys as that used were unsuitable for use where subjected to the continued action of salt water, though they might answer in cases where they would come in contact with it for a short period, as with torpedo boats carried on board of men-of-war. On the other hand, the builder of the aluminum boats used on the Wellman polar expedition says, regarding these tests, that he considers them altogether incorrect, as the experience of this expedition showed that the metal was not

corroded, and that there was no trouble from barnacles adhering to it. There have not yet been sufficient tests of this metal under the varying conditions of actual service to supply data from which any reliable conclusions can be drawn. The metal undoubtedly presents many advantages for shipbuilding work, but, apart from the objections raised by the Norfolk test, the softness of the metal and its liability to be punctured by slight blows are serious objections to it. Some of the alloys are harder than the pure metal, but even these have not as great powers of resistance as a piece of steel of equal weight, so that the advantage due to the lightness of the metal is not then apparent.

WE understand that one New York importer alone has placed orders for \$2,000,000 worth of silk webbing for belts, for early delivery. It is to be inferred from this that belts, with their ornamental auxiliaries, the buckles, are to be again the rage next Spring and Summer.

### Opening of the Kent & Stanley Co. Building.

PROVIDENCE, R. I., Nov. 8.—The new Kent & Stanley Co. building, which is in a practically finished condition, was formally opened for the first time to the public today. The attendance during the forenoon was not as large as expected, the occasional showers keeping many away. By noon the visitors began to arrive in greater numbers and the commodious elevator was filled at every trip. Hundreds of working people from all over the city took advantage of the opportunity to inspect the great building during the noon hour. The entire six floors and basement were thrown open and the people wandered about at will, over the six acres of floor surface, inspecting this really noteworthy business structure. Later in the day large numbers of ladies and business men visited the building. In fact, it was a sort of holiday occasion.

On the topmost floor was an artistic display of finished jewelry; the offices of the Kent & Stanley Co. were attractive with ornamental flowers and potted plants, and the novelty (to very many) of seeing the actual manufacture of jewelry was permitted as the entire plant of the Kent & Stanley Co. was in full operation. Superintendent Clark was everywhere looking after the comforts of the thousands of visitors.

Reeves' American Band was in attendance all day, and gave two prolonged concerts, lasting all through the morning and afternoon, and including the best and most popular music this excellent organization is capable of producing. Every visitor departed feeling that he or she had seen the leading jewelry structure in this country.

Augustus Schmidt, Asbury Park, N. J., son of the late jeweler Herman Schmidt, who died recently very suddenly, died at the home of his brother, in New York, on Monday of last week, of consumption.

### New York Notes.

G. M. Thurnauer sailed for Europe, Saturday, on the *Etruria*.

A judgment for \$75.15 has been filed against Elias Pilzele in favor of E. L. Anrich.

Lewisohn & Co. have entered a judgment for \$,95.53 against Frank X. Schoonmaker.

Max Freund & Co. have secured and entered judgment for \$706.51 against Isaac Boltansky.

A judgment for \$96.29 has been entered by the Meriden Britannia Co. against Edward J. Solomans.

The Ostby & Barton Co., Providence, R. I., have entered a judgment in this city for \$2,197.05 against Caroline Kopelovich.

The Manhattan Supply Co., of this city, have been awarded the contract for furnishing the Weather Bureau, of Washington, D. C., with 10 regulator clocks at \$10.98 each, and 50 alarm clocks at \$1.27.

An order by Judge Bishoff, of the Court of Common Pleas, Thursday, discontinued without costs the action of the Jas. A. Welch Co., against the American Watchmen's Time Detector Co. The suit was over a disputed amount due for advertising and was settled out of court.

John Connors, in the Butler Street Police Court, Brooklyn, Wednesday, was sent to the penitentiary for six months by Police Justice Tighe. The night before he entered the jewelry store of Rachel Lyons, 170 Columbia St., and stole four watches, but was captured after a chase of several blocks.

Cross & Beguelin are renovating and redecorating their store, 17 Maiden Lane. This work was made necessary by the falling of part of the coping and ceiling which occurred over a week ago. Fortunately no one was in the store at the time and thus no harm was done beyond the damage to the ceiling and furniture.

Daniel O'Connell, assignee of Wm. Downey who assigned June 8th was discharged from that position on his own application by Judge Bookstaver, of the Court of Common Pleas, Thursday, Mr. Downey having settled with his creditors at 50 per cent. The bond of the assignee was cancelled and the sureties on it released from liability.

During a quarrel with some boys election night, Philip Rodenburg, jeweler, 1997 Second Ave., drew a revolver and to frighten them away, so he says, fired in their direction. The bullet struck 13 year-old Katie Boyer in the leg. Rodenburg was arrested, but the girl's parents refused to prosecute him, and he was discharged by Justice Burke Wednesday.

Max J. Lissauer, a member of the Committee of Seventy, was the recipient of an informal ovation last week. All day Wednesday Mr. Lissauer's friends and associates in the trade filled the store of

Lissauer & Co., 12 Maiden Lane, and showered congratulations upon him over the result of the election in this city, and the part his committee played.

Friday the police arrested Richard Kust, said to be a jeweler of 542 E. 85th St., who was indicted with Mrs. Annie Mobens for causing the death of Agnes Berthold. Miss Berthold died in October from the result of a criminal operation to which it is alleged Mrs. Mobens and Kust were parties. Mrs. Mobens, as a Lexow witness, corroborated Dr. Whitehead, who swore that he paid money to certain lawyers and detectives on many occasions.

Sinnock & Sherrill, 21 Maiden Lane, have withdrawn their action in the Supreme Court against Chas. S. Platt, refiner, 29 Gold St. The suit, the developments of which have been chronicled in these columns, was to recover the value of gold which Sinnock & Sherrill claim was stolen by Foreman Ackerman, in their factory in Newark, N. J., and sold by him to Platt. On consent of counsel for both parties, Judge Truax Friday signed an order discontinuing the suit.

Tiffany & Co. are exhibiting one of the most valuable collections of relics of the Napoleonic dynasty in the world. They were purchased by H. De Young, Director-General of the California Midwinter Exposition, for the Memorial Museum, and the collection consists of over eight hundred medals, jetons and coins, in gold, silver, bronze and copper, and memorializes the leading events of the Napoleonic periods. Among the curios secured by Mr. De Young for the museum is part of the famous collection of Alessandro Castellani, which was sold at the Hotel Drouot, Paris, in 1884.

Catherine Fagan, 50 years old, was committed to Raymond Street Jail, Brooklyn, Saturday by Justice Walsh on a charge of having stolen numerous articles from the jewelry store of Benjamin F. Spink, 433 Fulton St., where she had been employed in the capacity of charwoman. The prisoner had been working for the jeweler for 12 years. A week ago Hermann J. Meyers, the superintendent, saw her remove a pair of sleeve buttons from the showcase and when he accused her of the theft she tearfully confessed her crime. Mrs. Fagan was subsequently arrested. A detective recovered a quantity of Mr. Spink's property and fifty pawn tickets for jewelry pledged. The woman admitted that she had begun to steal the jewelry a year ago last June. Mrs. Fagan will be arraigned for sentence to-day.

#### The Death of Jacob Schmid.

NEWARK, N. J., Nov. 8.—Jacob Schmid, a well-known Newark goldsmith, died at his home, 468 Washington St., late Monday night. He was 80 years old and had been identified with the business interests of Newark since his arrival here from Germany 46 years ago. He is survived by a widow and one daughter.

### Miniature of Mary, Queen of Scots.

MONSIGNOR SETON has just loaned to Tiffany & Co., New York, to place on exhibition for a few days, an invaluable original miniature of Mary, Queen of Scots. This miniature, a relic of the 16th century, is one of the historic portraits of the unfortunate queen. Its interesting history, briefly traced in the inscription on the silver plate set in the little wooden case which protects the portrait, reads:

This original portrait of Queen Mary Stuart is an heirloom in the family of the Setons of Parbroath, now of New York, into whose possession it came through their ancestor, David Seton, of Parbroath, who was Comptroller of the Scottish Revenue from 1589 to 1595, and a loyal adherent of his unfortunate sovereign. It was brought to America in 1763 by William Seton, Esquire, representative of the Parbroath branch of the ancient and illustrious family of the forfeited Earls of Winton.

It is not positively known upon what the miniature is painted, or who the artist was; his name is believed to be upon the back of the miniature, but on account of the miniature's age and its great value, neither Monsignor Seton nor his immediate ancestors have ventured to take it from its oval wooden frame for examination. This frame is of dark wood, resembling walnut, and is, in all probability, as old as the portrait itself. In this portrait the queen, painted from life, appears about 35 years of age, which would make the date of the portrait 1577.

An interesting description of this miniature is contained in the little volume recently published by the Harpers, entitled, "From the Books of Lawrence Hutton," where, in the chapter "On the Portraits of Mary, Queen of Scots," the writer says:

"An interesting miniature of the Scottish Queen is now in America. As it has never been engraved or publicly exhibited, it is little known to collectors. It represents her at half length. The dress is black, trimmed around the neck, the arms and upon the bosom with eider down.

"Between the large ruff of the down about her neck, and the neck itself is a fine upright collar of stiff lace. On the head, and falling back over the neck is a black velvet coif. The hair is what is called 'Titian gold.' The background of the picture is dark-blue, and contains the legend 'Maria Regina Scotorum.' In the case of polished wood which holds it is a plate with the inscription (as quoted above).

"There is a tradition that this picture was the gift of the Queen to her faithful servant, David Seton who, although a member of the Kirk of Scotland, was never counted among her personal foes. A copy of it was presented by the late William Seton in 1855 to Prince Labanof, who believed it to be from life, and surmised that it was taken during her captivity. The face is beautiful, but no longer young."

Tiffany & Co. have just made an extra reproduction of the original miniature—frame, case and every detail—for Seton Gordon, of Orange, N. J., a cousin of Monsignor. It is said that Monsignor Seton was offered \$10,000 for the original, but it is not for sale. The original miniature may be seen in Tiffany's window, Union Square and 15th St.



L. TANNENBAUM & Co.,  
IMPORTERS AND CUTTERS OF

**Diamonds and Precious Stones.**

Cor. Maiden Lane & Nassau St.,

NEW YORK.

25 Hatton Garden, London.

TELEPHONE, LONG DISTANCE, 1959 CORTLANDT.

## Special Announcement.

Mr. L. Tannenbaum begs to notify his customers and the trade in general, that he has largely extended his facilities for cutting and polishing. Hereafter he will cut and polish not only RUBIES and SAPPHIRES, which has been done for the past 15 years with increasing and gratifying success, but

## DIAMONDS

and all other stones which undergo this process.

Modern machinery of the best and most approved pattern, and workmen of the highest class will enable Mr. Tannenbaum to offer, direct from the cutter's hands, that excellent workmanship demanded by American buyers, at

## PRICES THAT DEFY COMPETITION.

Nor will buyers of Diamonds be the only people benefited. Mr. Tannenbaum imported a five years' supply of rough Rubies and Sapphires DUTY FREE under the old tariff. These goods are now being cut and polished and it is very evident that in these particular stones he can make UNAPPROACHABLE PRICES.

New York as the future Diamond Market is not a phantasy. American cutters will be shown an assortment of rough, at prices which will perhaps cause them to believe that this has already been brought about. All arrangements have been made by the firm for enormous shipments of DIAMONDS, EMERALDS, PEARLS, SPINELS, CATSEYES, MELLEES and all kinds of Precious Stones, although to-day the assortment offered by L. Tannenbaum & Co. ranks second to none in this country.

## A Selling Novelty

### Cup and Saucer,

With Solid Silver Spoon that can  
be retailed complete for

**\$1.00.**



Discount to the trade in dozen lots,  
33½ per cent. Net Cash.

[Cup and Saucer are assorted decoration.

**LEVY, DREYFUS & CO.,**

9 and 11 Maiden Lane, New York.

ART GOODS FOR JEWELERS.

No jeweler or watch repairer should be without a copy of "WORKSHOP NOTES," a new and very useful book for the workshop. Send for circular containing a complete index of the book, and judge of its merits for yourself.

### Greenleaf & Crosby Suffer a \$4,000 Robbery in New York.

JACKSONVILLE, Fla., Nov. 9. — Damon Greenleaf, senior partner of Greenleaf & Crosby, says that the article in one of THE CIRCULAR's contemporaries, in which it is stated that they were robbed of \$10,000 worth of diamonds in New York, is untrue. "It is greatly exaggerated," said Mr. Greenleaf yesterday. "It was about \$4,000 that was stolen from Mr. Crosby's trunk, at the St. Denis Hotel, in New York. We import diamonds in large quantities. When Mr. Crosby is in New York he puts in his spare time sorting out the fine gems. These are then taken away for mounting. In this way his stock on hand was small, and he kept them in his trunk instead of having them locked in the hotel safe. One day, on his return to the hotel, he found that his room had been entered and his trunk robbed. They were all unset stones, and worth about \$4,000. We have offered a reward of \$1,000 for the return of the gems, and \$1,000 to the officer securing them. As the thieves cannot pawn them for more than half their value, we are willing to offer this sum, and maybe we can get them back."

### Incorporation of the John S. Allen Co.

MINNEAPOLIS, Minn., Nov. 12. —The John S. Allen Co., of Minneapolis, have incorporated with a capital stock of \$25,000 to "conduct, maintain and carry on a mercantile business in the buying, selling, trading, manufacturing and repairing of jewelry, watches, diamonds, etc."

The promoters are John S. Allen, John J. Salfinger, Frank J. Salfinger, all of Minneapolis.

The stock and plant of the Acme Silver Plating Co., Toronto, valued at \$70,000, were sold at auction Saturday to the Manhattan Silver Plate Co., Lyons, N. Y., for \$16,000.

### Last Week's Arrivals.

**THE CIRCULAR** has perfected arrangements for obtaining the names and hotel addresses of all the latest buyers visiting New York, and each day posts in its office, 189 Broadway, a bulletin which every member of the trade is cordially invited to copy.

The following out-of-town dealers were registered in New York during the past week: J. R. Nutt, Akron, O. Imperial H.; M. Weber, Chicago, Ill., Astor H.; C. S. Davis, Philadelphia, Pa., Astor H.; A. C. Anderson, Toronto, Ont.; Astor H.; D. Gregory, Jr., Washington, D. C., Colonnade H.; O. E. Bell, Cincinnati, O., Broadway Central H.; S. K. Zook, Lancaster, Pa., Coleman H.; J. D. Ryan, Middletown, Conn., Normandie H.; F. H. Gale, Norfolk, Va., Grand Union H.; C. E. Wigginton, Woodward & Lathrop, Washington, D. C., St. Denis H.; W. M. Sturdy, Chartley, Mass., Astor H.; C. E. Giles, Chicago, Ill., Astor H.; J. Gumbinger, Jacksonville, Fla., Continental H.; J. J. Freeman, Toledo, O., Imperial H.; E. W. Trask, Aurora, Ill., Astor H.; J. T. Wise, Elmira, N. Y., Gilsey H.; J. Nelson, Dunkirk, N. Y., St. Denis H.; M. I. Epstein, Savannah, Ga., Union Square H.; E. Oppenheimer, Baltimore, Md., Marlborough H.; W. T. Marcy, Indianapolis, Ind., Broadway Central H.; M. Cohen, Washington, D. C., Marlborough H.; J. A. Caldwell, Philadelphia, Pa., Broadway Central H.

A gratifying state of affairs exists at the Trenton Watch Co.'s factory. The steadily increasing popularity of the new Trenton movements makes it difficult even with a full force working full time, to keep pace with orders.

# OPPENHEIMER BROS. & VEITH,

OFFER TO THE TRADE

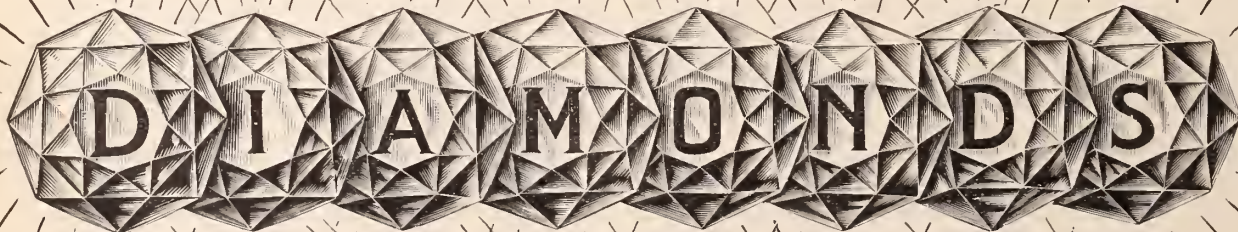

Cut by them according to scientific principles, at prices far below imported goods of the same quality.

NEW YORK, 35 MAIDEN LANE.

Amsterdam, 2 Tulpstraat.

London, Eng., 27 Holborn Viaduct.

**Providence.**

Samuel Moore has returned from an invigorating trip down on Cape Cod.

J. Stein, New York, was a visitor among the manufacturing jewelers the past week.

Tuck & McAllister, formerly of Bangor, Me., have removed to 112 Mathewson St., this city.

C. E. Sandland, of North Attleboro, Mass., has opened a branch enameling shop at 35 Potter St. this city.

Parks Bros. & Rogers are making preparations for their removal to quarters in the new Kent & Stanley Co. building.

John E. Leonhard, who has been doing engraving and etching for several years at his residence has now opened a shop at 98 Pine St.

J. W. Spence, president of the Racine Jewelry Mfg. Co., Racine, Wis., was in Providence last week visiting the manufacturing jewelers.

Henry H. Richardson, one of the oldest living manufacturers jewelers of this vicinity, has been confined to his house for several weeks with neuralgia. He is in the 80th year of his age.

Among the delegates to the Republican City Convention are: from the 6th Ward, Frederick Rueckert; 7th Ward, William H. Luther and William N. Otis; 9th Ward, John M. Buffinton.

The directors of the Manufacturing Jewelers' Board of Trade will meet on the 17th inst., for the last time previous to the regular annual meeting which occurs on the third Saturday in December.

Next Friday evening the Retail Jewelers' Association will meet for the purpose of completing their organization. Several of the officers are still to be elected, by-laws and a constitution to be adopted and plans laid for future work.

Ansel L. Sweet will continue the business of the late firm of George W. Willis & Co., under the firm name of A. L. Sweet & Co. He has placed a mortgage of \$5,500 upon his property. The disappearance of Mr. Willis left the condition of the firm in a somewhat discouraging condition, but Mr. Sweet gives the assurance that if he is not pressed that he will pull out of the present difficulties and soon be upon a sound basis.

The tax assessors of the Town of Cranston have just completed their labors and among the persons and corporations taxed for \$5,000 and over are the following: Dewey F. Adams, *et ux*, \$30,090; Arthur E. Austin, \$14,515; John Austin, \$104,230; George N. Babbington, \$6,700; Gustavus Bender, \$6,300; Chas. G. Bloomer, \$10,375; Chas. G. Bloomer, *et ux*, \$14,500; William W. Bloomer, \$6,200; Horace F. Carpenter, \$27,800; Stanton B. Champlin, \$36,955; Walter A. Griffith, \$5,780; Sylvester K. Merrill, \$7,530; Henry A. Hidden, \$7,000; Lorenzo Vaughn, *et ux*, \$11,500; Jonathan Wheeler, estate, \$12,150; Ellen E., wife of Walter E. White, \$6,555.

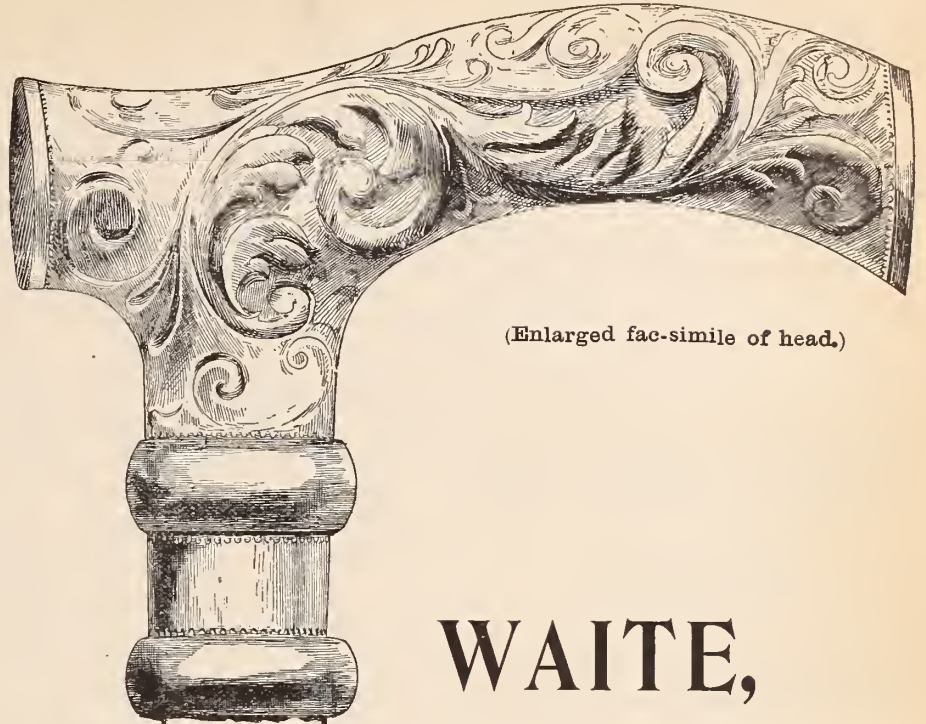

(Enlarged fac-simile of head.)

**WAITE,  
THRESHER**

**COMPANY,**

**Providence, R. I.**

OUR  
**CANE  
Stick  
And  
Lapel  
Pins.**

**PATENTED  
OCT. 23, 1894  
ARE  
THE  
PROPER  
THING.**

**HEADS  
ARE OF  
SOLID  
GOLD OR  
STERLING  
SILVER,**

**Artistically  
CHASED.  
STICKS  
ARE  
ENAMELED  
TO  
REPRESENT  
NATURAL  
WOODS.**

**THEY SELL AT  
SIGHT.**

**DIAMONDS.**

**Wm. S. Hedges & Co.,**

**Importers of Diamonds,**

And Manufacturers of **DIAMOND JEWELRY.**

**170 Broadway, New York.**

22 Holborn Viaduct, London.

**Alfred H. Smith & Co.,**

**IMPORTERS**

**DIAMONDS**

AND

**PRECIOUS STONES,**

**32 BROADWAY, COR. JOHN STREET,**

**NEW YORK.**

22 Holborn Viaduct, London, E. 1

**R. A. KIPLING,**

**Precious Stones**

AND **Fancy Goods**

Bought and Sold on Commission.

**19 RUE DROUOT,**

**PARIS, FRANCE.**

**ONE YEAR'S SUBSCRIPTION**

—TO—

**The Jewelers' Circular**

—At \$2.50,—

Entitles the subscriber to a copy of "WORKSHOP NOTES" free, a 200 page book, bound in cloth, containing a fund of information for the workshop that can be found in no other work.

The tools and machinery of the Utility Mfg. Co., 102 Orange St., are advertised for sale.

Fred. B. Ray, of the Darling Smelting & Refining Co., is making a business trip through Canada.

A. T. Wall & Co. are making preparations for an early removal to the Kent & Stanley Co.'s new building.

Greene & Knox Mfg. Co. are moving their heavier tools, machinery and safes to the new building of the Kent & Stanley Co., which they will in future occupy.

Assignee Henry W. Harvey, for Payton & Greene, states that the stock and property of that firm are being slowly disposed of at good advantage and expects to close up the firm's affairs shortly.

George F. Greene & Co. have been making extensive alterations and improvements in the office and factory at 111 and 113 Point St. They have taken additional shop room and have added numerous new tools and machinery.

The public will be interested in the announcement made Saturday that the New York, New Haven and Hartford Railroad managers have decided to run the 3 o'clock P. M. Shore Line express train between Boston and New York on seven days in the week in the future, beginning on Sunday, Nov. 18, thus affording two express passenger trains via the Shore Line on every Sunday, viz.: The Shore Line express at 3 P. M., and the Gilt Edge express at 5 P. M. This decision is the outcome of the long continued solicitation of prominent citizens of Providence headed by Nathaniel Barstow, of Barstow & Williams, and signed by a majority of the manufacturing jewelers of this city.

**Syracuse.**

E. C. Howe left Saturday for a week's stay in New York.

D. C. Draper, Fulton, and Chas. Morley, Jordan, were in town last week buying goods.

The funeral of Andrew H. Schilling, of Oswego, who was killed by the cars at the D. L. & W. station in this city on the 3d inst., was held from the home of ex-Mayor Mitchell, in Oswego, on Wednesday morning.

Fire in Louisville, Ky., last week damaged the business of D. E. Shoup, optician, to the extent of \$1,000.

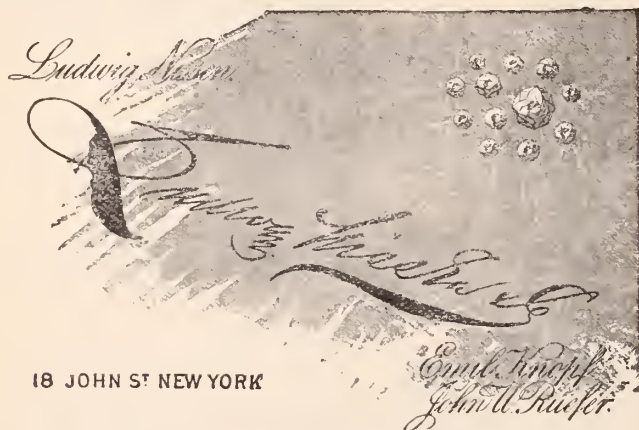

18 JOHN ST NEW YORK

**AIKIN, LAMBERT & CO.,**

CHICAGO BRANCH: 103 State Street.

No. 19 MAIDEN LANE, NEW YORK.

Manufacturers and Exporters  
Gold Pens, Holders, Pencils,



Toothpicks and Novelties.

**MERCANTILE**



**FOUNTAIN PEN.**

**Connecticut.**

E. J. Pierpont, the Naugatuck jeweler, has made arrangements to move to Arizona, and is selling out his stock.

C. C. Carroll, the Wallingford jeweler, moved into his fine new store in Wallingford's handsome block, Nov. 8th.

Alderman William H. Watrous, Republican, of Hartford, was elected to the General Assembly, as representative, Tuesday last, polling a large vote, his election being a gain of one Republican representative for that city.

President Arthur S. Goodman, of the National Retail Jewelers' Association, was in Hartford last week with Major C. H. Case, president of the Hartford Jewelers' Association and vice-president of the State organization.

Secretary F. L. Tibbals, Republican, of the Geo. H. Ford Co., New Haven, was elected on Tuesday one of Milford's representatives to the General Assembly, defeating a strong Democratic candidate, and triumphing in a town which for ages previous had gone Democratic.

Charles Teske, Hartford, has been appointed watch inspector of the Philadelphia, Reading and New England Railroad Co. Among certificates as to his ability in his line he has received one from C. M. Lawler, general manager of the Philadelphia, Reading and New England Railroad Co.

C. Rogers & Bros., silver plate manufacturers, Meriden, have petitioned the Meriden city government for authority to erect a frame addition to the factory. The same firm have been awarded \$1,500 damages by the city owing to a change of grade affecting their property. A like amount has been awarded the I. C. Lewis estate.

By a tremendous wash out on the Naugatuck R. R., at Ansonia, caused by the giving way of the banks of the canal, various manufactories were affected, among them the Phelps & Bartholomew Co. Their water power being cut off, the factory has had to cease work to a large extent for a few days pending the arrival and setting up of an engine which A. H. Bartholomew, of the company, ordered immediately.

Benjamin L. Hood, once a leading jeweler in Albany, N. Y., and one of the oldest men in the business, died Nov. 2. Many years ago he became twice the victim of robbers, who ransacked his store, and this crippled him financially. Since then he did business in a small way on South Pearl St. His son and two daughters survive him.

Early last Monday morning a robbery was committed at the jewelry store of H. Oberlin & Bro., Columbia, Pa. On Saturday night three gold chains and a locket were left in the window and were covered over with cotton. When the store was opened, Monday morning, it was noticed that a pane of glass on the side of the window was broken or cut out. The trinkets were not to be found.

ESTABLISHED 50 YEARS.

**RANDEL, BAREMORE & BILLINGS,**

IMPORTERS OF

**DIAMONDS,**

AND OTHER PRECIOUS STONES.

**FINE PEARLS A SPECIALTY.**

MANUFACTURERS OF

**DIAMOND JEWELRY,**

IN THE LATEST DESIGNS.

Diamonds Recut in Modern Styles or Repaired on Premises.

58 Nassau Street,  
29 Maiden Lane,  
NEW YORK.

1 Tulp Straat,  
AMSTERDAM.

1 St. Andrews St.,  
Holborn Circus,  
LONDON, E. C.



TRADE MARK.

ESTABLISHED 1841.

**CARTER, SLOAN & CO.,**

**MANUFACTURERS OF GOLD JEWELRY,**

No. 15 MAIDEN LANE,

NEW YORK.

A. CARTER JR  
A. K. SLOAN.  
C. E. HASTINGS.

GEO. R. HOWE  
WM. T. CARTER  
WM. T. GOUGH.

FACTORY, NEWARK, N. J.

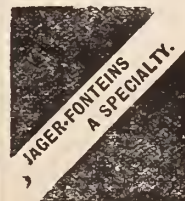

**JOHN N. DISSELKOEN,**

Cutter and Importer of

**DIAMONDS**

FACTORY  
73 LANGEBLEEKERSPAD  
AMSTERDAM.

19 East 16th St.,  
NEW YORK.



# A MODEL FACTORY BUILDING.

THE KENT & STANLEY CO.'S MAMMOTH NEW STRUCTURE, THE FINEST OF ITS KIND IN THE WORLD.

**P**ROMINENT among the many handsome factory buildings for which Providence is noted is the handsome structure built and occupied by the Kent & Stanley Co., on the Square bounded by Sabin, Aborn, Beverly and Mason Sts., in that

city. The property which it occupies was the location of the old-time popular skating rink, destroyed by fire last year. Mr. Edwin F. Kent, recognizing the advantages of the site, on his own responsibility purchased the property after the fire, though at that time the building occupied by the Kent & Stanley Co., at Eddy and Fountain Sts., was generally looked upon as a model factory, excellently planned and perfectly equipped.

Mr. Kent's foresight in the matter of the purchase of the new site was soon endorsed by his partners. Its proximity to the new railroad depot, which will be one of, if indeed not the finest, in the country is a guarantee of increasing values in that section of the city, while the increased shop room was something rendered imperative by the firm's constantly increasing business.

Work on the new structure which is depicted in one of the illustrations in this article, was begun on November 1, 1893, and October 1, 1894, the company was operating in its new quarters.

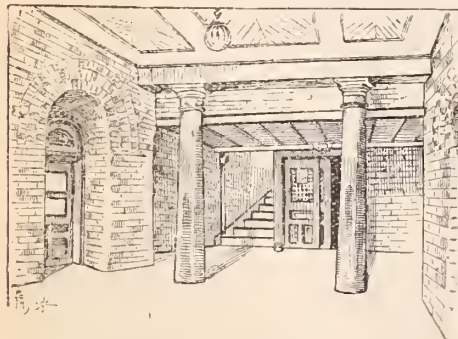

MAIN ENTRANCE ON SABIN ST.

The readers of the CIRCULAR can gather an idea of the immensity of the structure when it is borne in mind that it occupies an

acre of ground, rises seven stories above the foundation, has over 250,000 square feet of floor space, about 1,200 windows and required over five million bricks in its construction. While nearly all available space has already been leased, firms seeking modern quarters will do well to bear in mind that rentals are figured on a basis of 30 cents per square foot per annum, including power, steam heat water and elevator service.

The ground plan and character of the plot is excellently suited for the purpose to which it has been put. The L shaped formation gives it a frontage of 276 feet on Mason St., 221 feet on Aborn St., 106 feet on Sabin St., and 123 feet on Beverly St. A light well 40x200 feet extends from roof to basement in the main structure



THE KENT & STANLEY CO.'S BUILDING.

which with the additional advantage of four street frontages makes that great desideratum, good light, an assured fact for each tenant.

Red brick with brownstone trimmings was the material used for the walls, which rest on particularly solid foundations. At either corner on the Sabin St. facade are two handsome flag staffs held in place by artistic creations in wrought iron of dragons, one of which is incorporated in the initial letter beginning this article. Flags floating from these staffs bear, one, the company's trade mark on a white field and the other the national colors.

The two entrances to the building are well worthy of attention. Each shows a granite arch, while within enameled bricks of a light bluff tint please the eye and present an imperishable surface.

## THE KENT & STANLEY CO.

Our illustration shows the Sabin St. entrance with the handsome wrought iron elevator in the back ground, and two beautifully silvered supporting columns. The other entrance on Beverly St. is practically the same. Marble slabs for the names of the tenants is another feature not usually found in a factory building, and rapid running passenger elevators at either entrance afford quick access to, or egress from any floor. In the driveway running through from Sabin to Mason Sts., are two commodious freight elevators.

Floorings throughout are of maple, each floor being nearly an acre in area. The supporting columns are of iron, rising thirteen feet to the ceilings. Grinnell sprinklers and all other modern factory conveniences make the building a perfect one, whether from the view of the tenant, the insurance or the factory inspectors. Over 3,500 hands can find accommodation within its walls. Power and light are furnished by the company's private electric plant, one of the finest in the country.

The offices of the Kent & Stanley Co. are fitted up in oak, in the best taste, and pre-

sent an exceedingly attractive and handsome appearance. They occupy practically the whole of the Sabin St. wing on the sixth floor. Our illustration shows a view of the general office; adjoining it is the private office of Mr. E. F. Kent, which also connects with the director's suite.

The Kent & Stanley Co.'s shop, ever known as a model one, is in the new building better than ever. In one of the illustrations accompanying this article is shown a corner in the silver shop, a line in which the company is winning rapid recognition, and of which some of the productions, notably yachting trophies, have already been the subject of extended mention in the CIRCULAR.

A pioneer in selling its goods directly to the retail trade, the company, through its ten traveling salesmen and New York, Boston, Philadelphia and San Francisco offices offers a wide and varied line of goods. Some idea of its scope can be gathered from the fact that among them are:

**THE KENT & STANLEY CO.**

One-tenth and one-quarter Gold Seamless Wire Chains; Gents' Rolled Plate Vests, all Seamless Wire, 1, 2, 3, Strand Curbs; Dickens, Trace, Rope, Single Curb, Boston

**THE KENT & STANLEY CO.**

its predecessor, if that is possible. The business of the present Kent & Stanley Co. was first established in 1873 under the style of William H. Robinson & Co.,

**THE KENT & STANLEY CO.**

surviving partners, Edwin F. Kent and Arthur W. Stanley, under the old firm name. In 1887 these gentlemen purchased Mrs. Robinson's interest and continued under the style of Kent & Stanley. Under the new impetus, business during the two following years was doubled, but on Feb. 19, 1888, another fire once more interrupted operations by burning the factory entirely to the ground. Another shop was immediately found by Mr. Kent, and by noon of the day following the fire new machinery was already being put in position at the new shop, an instance of his indomitable will and prompt action in an emergency to which is due in a large measure the firm's success and high position to-day.

A lease of the ground on which the burned building had stood was quickly secured, and without the least unnecessary delay, Kent & Stanley began the erection of a building suitable to the needs of jewelry manufacturers which, when completed, ranked among the best factory buildings in the city. The firm took up its quarters in it and continued with increasing success. In February 1891, it was incorporated, under the title of the Kent & Stanley Co., being capitalized at \$300,000, represented in real property, and with charter rights for half a million. In November, 1893, the constantly increasing business necessitated larger quarters and the balance of the treasury stock was issued. In July, 1894, this additional stock had been issued, paid for in cash and invested in the new plant, which forms the subject of this article. It represents an investment of about \$350,000, and the total capital and surplus of the company in-



VIEW OF GENERAL OFFICE.

and Fancy Links; Red Gold and Platinum Links in all styles; Ladies' Lorgnette, Neck, Vest and Victoria Chains; 1,500 styles Gold, Silver and Plated Locketts and charms; White Stone Lace Pins and Brooches; Hair Ornaments; Chain Bracelets, Plate and Sterling Silver; Hat, Hair, Stick, Scarf and Bib Pins; Plated Sword Corsage Pins; Bracelet and Eye-Glass Chains.

In Sterling Silver Novelties, all warranted Sterling Silver are: Garters, Collarettes, Pocket Combs. Tie Holders; Belts with Silver, Pearl and Tortoise Shell Buckles, Paper Cutters and Weights, Match and Stamp Boxes, Trays, Letter Clips, Letter Openers, Book Marks, Prayer Book Marks, Thermometers and Calendars, Satchel Tags, Hat Marks, Coat Hangers, Souvenir Spoons, Umbrella Clasps, Pearl Teething Rings and Rattles, Glove Hooks, Button Hooks, Glove Stretchers, and Hat Buckles, Hair Pins in Celluloid, Real Tortoise Shell, Silver Mounted; Tooth Brushes, Shoe Horns and Letter Seals, Mirrors, Game Counters, Cigarette Cases, Sword Corsage Pins, Key Ring Chains, Bonbon Spoons, Pocket Knives, Scissors, Razors, Manicure Articles, Gold and Silver Mounted Suspenders, Novelties in Leather Card Cases, Memorandum Books, etc.; Stag Handle Cutlery Novelties, Corkscrews and many others.

The company issued last year one of the finest illustrated catalogues ever put out by a jewelry house and another is now in preparation which will be even better than

at 25 Calendar St. and the output consisted of chains. In 1882 Mr. Edwin F. Kent became a member of the firm and at once took an active interest in its welfare. In 1884 occurred the disastrous fire still remembered by the citizens of Providence, in

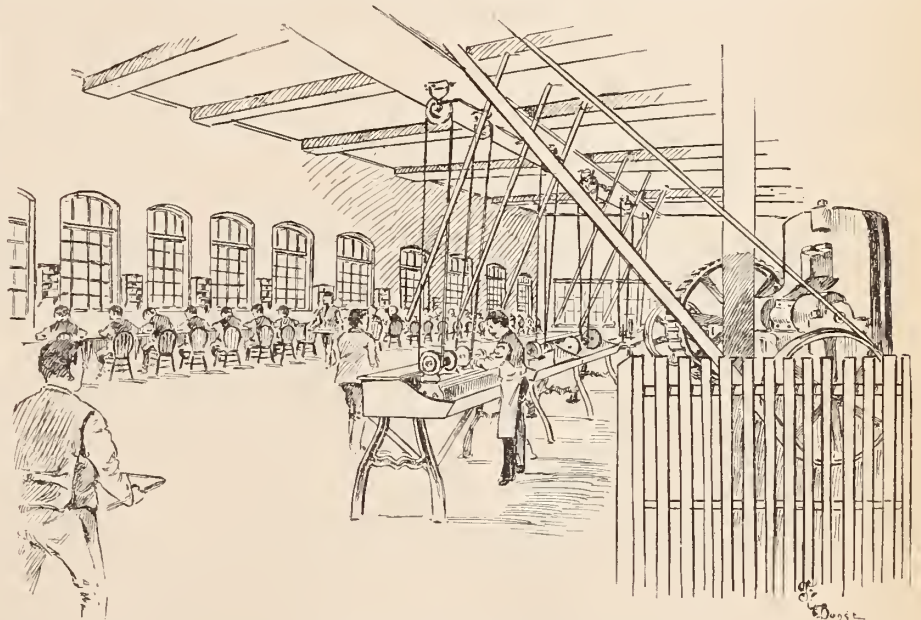

A CORNER IN THE SILVER SHOP.

which the factory was destroyed. New quarters were found at 7 Eddy St., and operations were again resumed. In 1885 Mr. Robinson died, and for nearly two years the business was conducted by the

vested in business is \$650,000. Its officers are: president, A. W. Stanley; treasurer, E. F. Kent; vice-president, J. S. Ingalls; secretary, J. D. Warren. George R. Clarke is superintendent and designer.

## Boston.

### TRADE CONDITIONS.

Many of the Boston jobbers are getting a more than satisfactory run of trade this month, and report that October business this year goes ahead of that in the corresponding month a year ago. One dealer states that his sales have approached 1892 figures. Nearly all the larger concerns are able to say that business is better with them than they anticipated. With the manufacturers in various parts of New England the slackness of a few months ago has to be balanced by over-time work now. This is learned from travelers for the prominent industries in the jewelry and silver lines. As a rule orders cover a wider range, variety being sought for to an unusual degree this season, with smaller volume in the items listed. There is considerable stocking up in progress, and holiday goods are moving with a fair degree of freedom.

A. D. Handy, formerly in the jewelry business in South Boston, has opened a place in the city proper as manufacturer and dealer in high grade stereopticons and supplies.

Richard Hills, who has been a watchmaker in Boston for upward of 50 years, was the subject of an illustrated biography in the *Boston Globe*, Nov. 2, being described as the oldest watchmaker in the city.

General Manager Carr, of the E. Howard Watch & Clock Co., who has just returned from a business trip to New York and Chicago, reports the clock department of the company's business booming at both cities, as well as here in Boston.

J. B. Humphrey is now the sole proprietor of the business carried on at the old stand of H. T. Spear & Son, the retirement of the joint purchasers with him of the stock having taken place at the beginning of the present month.

Buyers in Boston during the week included: James Holland, Concord, N. H.; J. Jefts, Fort Fairfield Me.; E. W. Folsom, Somersworth, N. H.; Everett S. Albee, Wolfboro, N. H.; Dana N. Coy, Windsor, Vt.; A. F. Grimes, Peterboro, N. H.; M. M. Genter, Rockland, Me.; W. P. Meyers, Derry Depot, N. H.; C. F. Pettengill, Quincy.

Herbert W. Smith, formerly in the jewelry business at Winter Hill, Somerville, Mass., has entered the employ of E. B. Floyd & Co. as traveling salesman. Mark B. Flanders is also back with the house, and Harry E. Chapman, who was for a number of years the bookkeeper for the old firm of Floyd, Pratt & Rounds, has been engaged by Mr. Floyd in his former capacity.

Alfred A. Marcus & Son, diamond brokers and real estate dealers, Exchange Place, have filed a petition in insolvency. The members of the firm are Alfred A. and Simeon Marcus. The former has a rather unique business career, and has figured in the insolvency court once before. He is

also said to have drawn a big prize at one time in a lottery. About two months ago he was the victim of an assault, the attacking party being a member of the Boston City Council. A very light fine was imposed, however, the court taking the ground that the affair was not entirely unprovoked by the plaintiff.

## The Attleboros.

S. O. Bigney and C. E. King have returned from the west.

The Curtin Jewelry Co. have enlarged their quarters in the Horton block.

A. M. Barden has been confined to his residence over a week with severe illness.

R. M. Walker and Helen Estelle Marsh were made Mr. and Mrs. Walker Friday evening.

Among the many suggestions for new names for North Attleboro are Sterling, Braston, Richdon, Draper and Richards.

During the past week there have been many advertisements inserted in the local papers for fine chainmakers which indicates an increase in this line.

David J. White, of the Standard Seamless Wire Co., was elected councilman in Pawtucket by a large vote and his success has made the Republicans talk strongly of making him their next candidate for Mayor.

## Philadelphia.

Benjamin Greenland, Manayunk, has returned from a gunning trip throughout the State.

C. R. Smith & Son have announced a general clearance sale preparatory to retiring from business.

Martin Sheridan, 10th and Chestnut Sts., has returned to business after being laid up with a severe attack of typhoid fever.

A. Koettnitz, formerly with Chris. Loefler, 1004 Girard Ave., has accepted a position with D. C. Schumo, 2258 N. Front St.

A colored youth named Percy Williams was held in \$500 bail on Wednesday for stealing a gold watch case from the store of William Silverstone.

Philip Cohen was arrested in New York last week, and brought to this city on the charge of stealing diamond ear-rings valued at \$165, from A. S. Millard, 713 Sansom St. He was committed for trial.

Out-of-town buyers here the past week included: R. G. Porter, Woodbury, N. J.; Jacob Braddock, Medford, N. J.; John Dewer, Bryn Mawr, Pa.; A. Dertinger, Egg Harbor City, N. J.; C. F. Rudolph, Wilmington, Del.

An opinion was filed in the United States Circuit Court, on Wednesday, by Judge Acheson, deciding the suit of Receiver Fisher, of the Spring Garden National Bank, against Simons, Bro. & Co., in favor of the firm. The action grew out of a claim to recover upon a renewed promissory note for \$5,000.

Early on Friday morning officer Ennis, captured John Broadhead while attempting

to break into the jewelry store of Milton M. Bovard, 4369 Cresson St., by a rear window. Before the magistrate Broadhead said he was full of whisky at the time, and didn't know what he was doing. He was held in \$1,500 to answer for attempted robbery.

## Springfield, Mass.

T. N. Glover, the optician, has been elected junior warden of Hampden Lodge of Masons.

Among the traveling men here within a week were: E. A. Bigelow, Hayden Mfg. Co.; H. C. Schwartz, Kremenz & Co.; Mr. Goldsmid, Leopold Weil & Co.

A. E. Hall's store, Williamstown, was burglarized one night last week and over \$200 worth of goods was stolen. The post office is located in the store and the burglars probably thought they could make a much larger haul than they did.

Harry Sanderson, a South Deerfield watchmaker, has been arrested on the charge of embezzling a gold watch case belonging to a Mrs. Childs. Sanderson was formerly employed in a Northampton jewelry store but recently has been engaged in watch repairing in South Deerfield. Failing to produce a case belonging to Mrs. Childs, a warrant was sworn out against him and he has been placed under bonds of \$500 for trial before Justice Malone in Greenfield next Saturday.

The embossed tea set shown in the artistic full page display of the Middletown Plate Co., elsewhere in this issue, will commend itself at once to all who see it. Butter, syrup, spoon holder and kettle all match, and the makers confidently assert that the set is the finest ever made in white metal. This is only in line with the recent productions of the Middletown Plate Co., which are all of more elegant design than ever before.

The manicure sets shown by Foster & Bailey, Providence, R. I., are meeting with the excellent success which they merit. The steel parts are all from the famous Henckles factory and the mountings are in tenth gold or sterling silver. Each piece is numbered and can be ordered separately and a particularly good feature is in the packing of the goods which are put up so that a traveler can put them in his trunk in a very small space.

The cane head illustrated on another page, by the Waite, Thresher Co., Providence, R. I., is a fac-simile of one of the heads on their cane pins. They are made in solid gold and in sterling silver, the sticks being enameled to represent natural woods. As stick and lapel pins they are meeting with enormous success, and the jobber who doesn't carry them is missing a quick selling and profitable article. These pins are fully protected by patents.



### News Gleanings.

E. Curtis is a new jeweler in Lemont, Ill.  
Frank H. Cary, Lebanon, O., has assigned.

Paul Helbert, Dayton, O., has sold out to quit business.

Elmer Brown has opened a jewelry store in Harrisburg, O.

Geo. F. Blakeslee has opened a jewelry stock in Marion, Ia.

E. E. Alexander will open a jewelry store in Delanson, N. Y.

William Boadenhamer, Hanover, Pa., is having his store improved.

Lyon & Kylling, Danville, Ill., have disposed of their jewelry store.

John H. LeRoy, Fairburg, Neb., has given a mortgage for \$1,200.

W. H. Kress, Elk Rapids, Mich., has removed into a renovated store.

The J. G. Willeke Jewelry Co., Springfield, Mo., opened for business Nov. 3d.

The assignee has sold the stock of N. B. Shyer & Co., Nashville, Tex., to Max Levy.

A. J. Clark, formerly of Dayton, Tenn., is now located at 135 E. Main St., Lexington, Ky.

C. C. Budd, jeweler, Valparaiso, Ind., moved into his new quarters, on Main St., last week.

Robert Graham, Rhinelander, Wis., will erect a jewelry store and residence before the Winter.

George H. Frees, jeweler, Reading, Pa., will open a place of business at 348 N. 9th St., in a few days.

A. R. Baldwin, of Baldwin & Martin, Winchester, Ky., has given a real estate mortgage for \$2,100.

Marshall & Bragg, Rutland, Vt., removed into their new store on the east side of Merchants' Row, Nov. 6.

J. Weber, jeweler, Montfort, Ill., has formed a partnership with his brother at Lancaster and has left Montfort.

Baldwin Wassmuss, jeweler, Holbrook, Long Island, died on the morning of Nov. 3, of pneumonia, aged 72 years.

T. A. Haney, recently of Lyons, Kan., has located in Springfield, Mo., and will engage in the jewelry business.

An optical parlor, at G. Lanz's jewelry store, Norristown, Pa., has been opened, and is in charge of a lady graduate optician.

The death occurred recently of Mrs. Elizabeth Whatnough, mother of John Whatnough, jeweler, 519 E. 18th St., Kansas City, Mo.

David F. Fero, who has been in business in Corning, N. Y., for 30 years, is closing out with the intention of retiring altogether from business.

Fire early on the morning of Nov. 2d slightly damaged the store occupied by Levy Segall, jeweler, Milwaukee, Wis. Insurance, \$500.

William Smith, charged with breaking and entering the jewelry store of M. J. Cohen, Jacksonville, Fla., has been turned over to the county authorities.

The board of directors of the First National Bank, Waynesboro, Pa., have elected E. Elden, jeweler, Chambersburgh, president of that institution.

William H. Joslin, once a prosperous business man of Grand Rapids, Mich., conducting a jewelry store in the Kendall block, died recently at the Soldiers' Home.

E. Kerper, Pottstown, Pa., has just completed a supplementary course of optics in the Philadelphia Optical College. He is also a graduate of the Easton School of Optics.

The jewelry store of J. E. Eckert, Marengo, Ia., was burglarized recently. The burglars effected an entrance through the back window and stole between \$75 and \$100 worth of goods.

J. F. E. Weiland has purchased the interest of his father in the jewelry store of Weiland & Son, Fremont, Neb., and Mr. Wieland, Sr., will leave for his old home at Vienna, Austria.

Mrs. A. E. Martin, of Cooke & Martin, Jacksonville, Fla., has had a return of the illness from which she

suffered all Summer. She is now able, however, to again attend to business.

B. F. Johnson will open a jewelry store Nov. 12th in Trumansburgh, N. Y. The store will be beautifully furnished in modern style. E. J. Kneeland has engaged with Mr. Johnson as watchmaker and optician.

A few days ago John Bartley, Jas. Cole and William Campbell were arrested charged with robbing a jewelry store at Green Castle, Mo. Several watches and other jewelry were found on the person of John Bartley.

Two boys aged 10 and 12 years broke into a jewelry store in Lima, O., and carried off a lot of jewelry. They escaped on a freight car to Bucyrus where they were arrested, and while in jail made a full confession of their guilt.

Burglars made a good haul at the jewelry store of Mrs. Mattie W. Parry, 1010 7th St., Washington, D. C., about 4 o'clock last Wednesday morning. The show window was smashed and about \$100 worth of jewelry taken.

A. J. Shriever, jeweler, 1308 7th St., Denver, Col., was arrested last week on a warrant charging him with receiving stolen goods. Mrs. J. H. Wright was the complaining witness, she having lost by theft a diamond and garnet ring valued at \$150, and a gold necklace worth \$15. Schriever purchased the goods from a 14-year-old girl for \$20.

## A. WITTNAUER,

Successor to I. EUGENE ROBERT & CO.,

19 MAIDEN LANE, - - NEW YORK.

## Swiss Watches and Movements

—OF—

ALL DESCRIPTIONS, STYLES AND SIZES

—AND—

IN VARIOUS GRADES.

## Split Seconds, Minute Repeaters and Novelties.



Traveling representatives may consider these columns open for the publication of any news or items of interest regarding themselves or their confreres.

**T**RAVELING men in Indianapolis last week included W. P. Hanford, Roseman & Levy; Fred. Philipps, A. & J. Plaut; L. Rauch, Strauss & Stern; M. Fairchild, Leroy W. Fairchild & Co.; M. Fowler, Fowler Bros.;

Robt. Moorhead, R. L. Moorhead & Co.; E. R. Bennett, Foster & Bennett; Ernest Block, W. & S. Blackinton; W. S. Creveling, Chas. Ahrenfeldt & Son; Jos. Hazelton, Jno. Holland Gold Pen Co.; Daniel Earl, and a representative of Baldwin, Ford & Co.

Flint Bowen, Kansas City, Mo., is on his western trip of six weeks. He will go as far as Helena, Mont.

E. H. Lowman, of Lissauer & Co., New York, returned Monday from a successful trip through the west. After replenishing his stock of samples he will start out again in a few days.

The following traveling salesmen passed through Detroit last week: F. C. Allen, for A. Wittnauer; G. W. Birnbaum, Ehrlich & Sinnock; Mr. Stine, Wendall Mfg. Co.; C. Pettit, Hayden Mfg. Co.; F. B. Brigham, for F. S. Gilbert; Mr. Frazer, H. S. Smith & Co.; Mr. Kenion, H. D. Merritt & Co.; Mr. Gallagher, Sinnock & Sherrill; Mr. Fowler, Fowler Bros.; W. S. Smith, Tor-

toise Shell Novelty Co.; F. C. Faxon, Royal Silver Novelty Co.; R. M. Woods, Dominick & Haff; C. W. Cary, J. B. & S. M. Knowles Co.; Mr. Arnstine, Arnstine Bros. & Mier; E. S. Shepherd, R. F. Simmons & Co.; William Jarchow, C. F. Rumpff & Sons; and G. W. Hull, Silver Plate Cutlery Co.

Travelers in Pittsburgh, Pa., last week were: H. D. Mix, Wightman & Hough Co.; Stephen B. Kent, Wm. H. Ball & Co. and Geo. O. Street & Sons; Jos. J. Sideman, Ferd. Fuchs & Bros.; Gus W. Strandberg, E. L. Spencer & Co.; Mr. Simons, Stern Bros. & Co.; A. A. Wood, Howard Sterling Co.; H. A. Scofield, Lincoln, Bacon & Co.; Hubert Somborn, Albert Berger & Co.; E. T. Hopkins, Meriden Silver Plate Co.; Harry B. Kennion, H. D. Merritt & Co.; A. Kaufman, Bruhl Bros. & Co.; Fred Baker, Hayden W. Wheeler & Co.; B. E. Osgood, Bioren Bros.; Edward C. Stone, James W. Gibson Co.; Monroe Engelsman, for Maurice Weil; G. W. Hull, Silver Plate Cutlery Co.; Mr. Schwab, New Haven Clock Co.; R. M. Woods, Dominick & Haff; Mr. Tinker, for W. B. Durgin; F. L. Mueller, for Reinholdt G. Ledig; Wm. W. Middlebrook, B. A. Ballou & Co.; and A. Peabody.

Energetic travelers noticed in Syracuse the past week were: W. H. Lee, W. E. Webster & Co.; R. E. Kehl, F. H. Noble & Co.; Harry C. Larter, Hayden W. Wheeler & Co.; W. S. Campbell, Day & Clark; Louis Lassner, Goodfriend Bros. & Lassner; W. R. Washburne; W. H. Bryant, T. G. Hawkes & Co.; Ernst Gideon Bek, for Richard Horstman; T. A. Ball, Montgomery & Co.; Mr. French, French & Franklin Mfg. Co.; Wm. Egerton Bliss, Meriden Sterling Co.; E. W. Dellar, Wm. S. Hicks' Sons; Mr. Smith, Smith &

Knapp; T. C. Faxon, Royal Silver Novelty Co.; Charles W. Hempel, Sandland, Capron & Co.; Robert Welch, Welch & Miller; Louis A. Scheuch, Jeannot & Shiebler; J. L. Granbery, D. D. Coddling; Geo. C. Moody, E. G. Webster & Son; F. O. Spencer, Seliger, Toothill Co.; J. S. Franklin, L. Tannenbaum & Co.; G. B. Osborn, Wm. Smith & Co.; S. Mathez for Edmond E. Robert; Frank H. Dana, G. E. Luther & Co.; Chas. F. Osgood, H. H. Curtis & Co.; Chas. N. Swift, Chas. N. Swift & Co.; Sam Cohn, H. E. Oppenheimer & Co.

Travelers who visited the Hub during the past week included: L. Jones, R. F. Simmons & Co.; Mr. Smith, S. Cottle Co.; W. S. Campbell, Day & Clark; Charles Medbury, F. M. Whiting & Co.; Mr. Joralemon, A. Joralemon & Co.; Henry Fera; Mr. Matschke, Kuhn, Doerflinger & Co.; J. E. Alexander, Frank W. Smith; George Beardsley, George W. Shiebler Co.; Eugene H. Cox, Sussfeld, Lorsch & Co.; Henry Thresher, Waite, Thresher & Co.; Herbert E. Slater, Champenois & Co.; James F. Barclay, R. Wallace & Sons Mfg. Co.; Mr. Call, Simpson, Hall, Miller & Co.; J. H. Messler, T. B. Clark & Co.; W. Wildprett, Wildprett & Saake; Eugene Thomas, Jr., Woodman-Cook Co.; Louis Busiere, Poole Silver Co.; A. W. Pierce, Winsted Optical Co.; Nelson Davis, B. S. Freeman & Co.; Mr. Noble, Payton & Kelley; C. S. Sweetland; C. Kaste, Kipper, Vogel & Co.; J. E. Blake, Blake & Clafin; A. H. Wade, Wade, Davis & Co.; George Hutchison, Hutchison & Huestis; Nat. Barstow, Barstow & Williams; T. B. Wilcox, Pairpoint Mfg. Co.; G. W. Cheever; Frank Sherry, Jos. Fahys & Co.; F. C. Cam, Mgr. Brooklyn Watch Case Co.; Mr. Tirrell, M. Fox & Co.



## SOMETHING NEW !

### Interchangeable Initial Watches.

We have placed on the market a line of "Charmilles" watches cased in steel, black oxydized with GOLD INITIALS in relief. These initials are interchangeable with the backs; are 10 karat gold, cost but little extra, and make

#### A VERY ATTRACTIVE WATCH.

INITIAL watches appeal to public sentiment and taste. The advantages of INTERCHANGEABLE Initial Watches at LOW PRICES will be appreciated by all.

Ask Your Jobber For Them.

A. C. SMITH WATCH CO, - 177 Broadway, New York.

## ADVERTISING HINTS FOR RETAIL JEWELERS.

BY CHARLES AUSTIN BATES.

The Editor of THE JEWELERS' CIRCULAR has asked me to contribute a series of articles on retail jewelry advertising.

It is my desire to make these articles as useful as possible and to that end, an invitation is extended to retailers to send to me any of their advertisements which they would like to have criticised. It may be that there are some questions which they will care to ask and that I can answer.

Each week I will give several examples of advertising, which will illustrate my ideas on the subject. I do not present these advertisements with the claim that they are perfect, but only with the hope that they will contain some useful suggestion, and that some dealer at least will find that by making slight changes in them, as local conditions require, they will be able to make use of them, and so relieve themselves of one detail of their business.

### PART VI.

I AM receiving quite a number of advertisements for criticism. This little local notice comes from St. Joseph, Mo. As it stands there is nothing about it to criticise. It is a mere statement of removal:

L. Burnett & Co., our jewelers, moved into their new quarters, Tuesday. They are now located in the building lately vacated by B. F. Harpster.

and I presume was not really intended to be much of an advertisement.

If it has not already been done, I should think that Burnett & Co. ought to have a complete write-up of their new place published in the papers. It should be interestingly written if possible, and should not be too glaring in its advertising features. To make a good advertisement out of a reading notice, it is not necessary to drag your own business into every other line. The notice should talk about jewelry in general, and then take up a dozen or more special things in the new store of Burnett & Co., calling the readers' attention to these things as items of interest and as things to be bought. Above all things, avoid the "spread eagle" style, and do not tell people how many square feet of floor space, how many show cases and how many gas jets there are in the room. A New York merchant recently said to me "Everybody knows that we have counters and show-cases and clerks and goods in the store. What we want is something different from that, something interesting about the goods themselves."

Nine reading notices out of every ten are spoiled by the frantic efforts of the advertiser to get advertising into every line.

Here is a little ad. from Indianapolis that, to a certain degree, demonstrates what I have been saying. It is a little bit

#### The Diamond Bank

pays the depositor hourly dividends in personal gratification; pays always "on demand" in gold, if gold is required or desired; pays it, too, in any country on the globe, without discount or identification. Call on J. C. Sipe, room 4. Old Sentinel Building, and examine his large stock of fine diamonds.

too sure to carry out my idea exactly, and it may be that some people would not find it quite plain. Of course you will say, any one of ordinary intelligence will know what it means at once, but just think over the

list of people you know, and see how many of them possess ordinary intelligence. You remember the old Quaker's remark to his wife—he said: "All the world are fools but me' and thee, and sometimes I think thou art a little queer."

There are a great many people in the world who do not know enough to go in out of the rain, and the money of these people is just as good as that of anybody else.

You cannot make your advertisements too plain. It is a great deal better to have them too plain than not plain enough. If you make the ad. so plain that even a fool can understand it, you are sure to be understood by the smart people.

\* \* \*

Another advertisement from Indianapolis is not good because it is apparently written merely to fill space. Walk & Son

#### SHIPS THAT PASS IN THE NIGHT

brought our celebrated Swiss Watches all the way from Switzerland. A finer line of time pieces are not to be found anywhere.

Come and see us.

## Julius C. Walk & Son,

Leading Jewelers,

12 East Washington St.

evidently had nothing in particular to say on that particular day. As a general thing their advertisements are exceptionally well written. Most all of them convey some information in a straightforward way. I remember several years ago they published a series of advertisements about the precious stones which were emblematic of the months of the year. I think I have mentioned this series before without giving the name of the advertiser.

\* \* \*

From Burnett & Co., St. Joseph, Mo., comes a display ad., which is about one hundred per cent. better than the other advertisement. It occupied a space three columns wide and about 15 inches long in its original form.

As an ante-election effort it is quite commendable. There is just enough humor

about it to make it please most people. The statement that money will be refunded for unsatisfactory goods is a very strong one, and I am surprised that it is not made use of a great deal oftener.

Perhaps the most successful clothing house in New York is that of Rogers, Peet & Co. They have made a sort of trademark out of the sentence, "Money back, if you want it." It has been a great drawing card for them, although, as a matter of fact, I suppose that almost any reputable dealer will refund money for unsatisfactory goods

## ?? ? QUESTIONS.

### WHAT IS A DEMOCRAT ?

A Democrat is a man who believes in Free Trade, but not to an alarming extent, especially if it hits on something that he is interested in. He has a special fondness for holding office.

### WHAT IS A REPUBLICAN ?

A Republican is a man who believes in Protection, but not to an alarming extent, especially if it hits on something that he is interested in. He has a special fondness for holding office.

### WHAT IS A POPULIST ?

A Populist is a man who believes that rich men ought to divide up with the poor men, but not to an alarming extent, especially if he is the one who has to divide with the other fellow. He has a special fondness for holding office.

## WHAT IS THE DIFFERENCE ?

There is not a bit of difference between a Democrat, a Republican, and a Populist. They are all human, all after the almighty dollar and the place to get the most for it. A great many of them have

## DISCOVERED

That ours is the best place. We are now selling

## Watches, Clocks, Jewelry,

AT A REDUCTION OF 25 PER CENT.

and give a guarantee with every article bought, and if it is not as represented, bring it back and your money will be refunded.

Try us and you will always trade with us.

Yours respectfully,

**L. BURNETT & CO.**  
Severance, Everest, St. Joseph, Mo.,  
Cor. 7th and Felix.

without quarrelling about it. Rogers, Peet & Co. carry the matter out in a very nice

## "CHECK."

If the bargain is not satisfactory, return the clothes within ten days and you shall have your money (dress suits and white goods excepted).

If they do not wear well, we shall be glad to pay for the loss at any time.

The price is the same to everybody, and as low as anybody anywhere sells such clothing for; and the quality is as stated.

This check identifies the transaction. Keep it.

Besides we ask as a favor that you inform us of any cause for dissatisfaction of any sort.

We are doing our best to make a perfect store and perfect salesmen and perfect merchants.

Help us by pointing out our shortcomings.

# CLASSIFIED INDEX TO ADVERTISEMENTS.

All Advertisements are entitled to one insertion under proper heading. Extra insertions, \$6.00 per annum  
Extra Headings, \$12.00 per annum.

	Page.		Page.		Page.
<b>Art Pottery, Bric-a-brac, Etc.</b>		<b>Ebony Goods.</b>		<b>Safes.</b>	
Bing, Ferdinand & Co., 106 Grand St., N. Y. . . . .	42	Provenzano, J. N., 39 Union Square, N. Y. . . . .	17	Mosler, Bahmann & Co., 518 B'way, N. Y. . . . .	45
Bradley & Hubbard Mfg. Co., Meriden, Conn	14	<b>Fine Stationery.</b>		<b>Sample Trunks.</b>	
Glaenger, Leon J. & Co., 80 & 82 Chambers St., N. Y. . . . .	3	Parsons & Greene Co., 18 Murray St., N. Y. . . . .	5	Crouch & Fitzgerald, 161 Broadway, N. Y. . . . .	5
Healey, M. & E., Washington, D. C. . . . .	19	<b>Furniture.</b>		<b>Show Cases.</b>	
Hinrichs & Co., 29 & 31 Park Place, N. Y. . . . .	47	Smith, Geo. Wm., 3907 Powelton Ave., Phila., Pa. . . . .	42	Smith, B. & W. B., 220 W. 29th St., N. Y. . . . .	48
Leonard, P. H., 76 & 78 Reade St., N. Y. . . . .	32c	<b>Gold and Rolled Plate Jewelry.</b>		<b>Silver Plated Ware.</b>	
Le Boutillier & Co., 860 Broadway, N. Y. . . . .	18	Foster & Bailey, Providence, R. I. . . . .	13	Middletown Plate Co., Middletown, Conn. . . . .	15
Levy, Dreyfus & Co., 9 & 11 Maiden Lane, N. Y. . . . .	24	Smith, Wm., & Co., 5-7 Maiden Lane, N. Y. . . . .	14	Bell, O. E. & Co., 51 E. 4th St., Cincinnati O. . . . .	36
Vantine, A. A. & Co., 877 & 879 B'way, N. Y. . . . .	45	<b>Gold Jewelry.</b>		Pairpoint Mfg. Co., New Bedford, Mass. . . . .	5
Straus, L. & Sons, 42 to 48 Warren St., N. Y. . . . .	41	Carter, Sloan & Co., 15 Maiden Lane, N. Y. . . . .	24c	Rogers & Bro., 16 Cortlandt St., N. Y. . . . .	10-11
<b>Assayers &amp; Refiners.</b>		Aikin, Lambert & Co., 19 Maiden Lane. . . . .	8-24b	The Wm. Rogers Mfg. Co., Hartford, Conn. . . . .	5
Baker, Geo. M., Providence, R. I. . . . .	39	Cross & Beguelin, 17 Maiden Lane, N. Y. . . . .	4	Webster, G. A., Chicago, Ill. . . . .	35
Goldsmith Bros., 63 & 65 Washington Chicago, Ill. . . . .	34	Hedges, A. J. & Co., 6 Maiden Lane . . . . .	45	<b>Sterling Silver Novelties.</b>	
Guild & Gardner, 189 Eddy St., Providence, Providence, R. I. . . . .	8	<b>Gold and Silver Novelties.</b>		Bachrach & Freedman, 1 & 3 Union Sq., N. Y. . . . .	17
Le Long, L. & Bro., Newark, N. J. . . . .	48	Riley, John A., & Sloan Co., Ltd., Broadway and 17th Street. . . . .	46	Codding Bros. & Heilborn, North Attleboro Mass. . . . .	42
U. S. Smelting & Refining Works, 25 John St., N. Y. . . . .	48	Reddall, John W. & Co., Newark, N. J. . . . .	7	Hagan, White & Co., 243 W. 23d St., N. Y. . . . .	16
<b>Auctioneers.</b>		<b>Guards, Scarf Pins.</b>		Kent & Stanley Co., Providence, R. I. . . . .	24d, 25
Boyle, Davis & Goodman, 63 5th Ave., N. Y., 611 Pennsylvania Ave., Washington, D. C. . . . .	16	Security Mfg. Co., 7 Astor House, N. Y. . . . .	42	Richardson, Enos, & Co., 23 Maiden Lane. . . . .	41
Comrie, A. J., 22 John St., N. Y. . . . .	31	<b>Horological Schools.</b>		<b>Sterling Silverware.</b>	
French, J. H., P. O. Box 2775, N. Y. . . . .	39	Chicago Watchmakers' Institute, Chicago, Ill. . . . .	33	Campbell-Metcalf Silver Co., Providence, R. I. . . . .	41
H. M. Rich & Co., 21 School St., Boston, Mass. . . . .	16	Parson's School for Watchmakers, Peoria, Ill. . . . .	33	Fuchs, Ferd. & Bros., 808-810 Greenwich St., N. Y. . . . .	45
<b>Brownie Novelties.</b>		Philadelphia College of Horology, 623 Heed Building, Phila., Pa. . . . .	8	Towle Mfg. Co., Newburyport, Mass. . . . .	47
Griffith, R. L. & Son, 129 Eddy St., Provid- ence, R. I. . . . .	41	<b>Insurance.</b>		Wallace, R. & Sons Mfg. Co., 3 Park Place, . . . . .	6
Wm. Hendricks Sons, Louisville, Ky. . . . .	32	Fidelity & Casualty Co., 140-146 Broadway. . . . .	47	Wood & Hughes, 16 John St., N. Y. . . . .	39
<b>Badges, Medals, Etc.</b>		<b>Jewelry, Silverware and Optical Cases.</b>		<b>Spectacle and Eyeglass Cases.</b>	
Stockwell, E. R., 19 John St. N. Y. . . . .	16	Jackson, S. C., 180 Broadway, N. Y. . . . .	12	White, W. B. & Son, Boston, Mass. . . . .	39
<b>Carborundum.</b>		<b>Jobbers, Watches, Diamonds, Etc.</b>		<b>'Thimbles.</b>	
The Carborundum Co., Monongahela, Pa. . . . .	8	Allen, Benj. & Co., Chicago, Ills. . . . .	16 33	Ketchum & McDougal, 198 Broadway, N. Y. . . . .	8
<b>Chains.</b>		Aikin-Lambert Jewelry Co., 19 Maiden Lane 8-24b	31	<b>Tortoise Shell Goods.</b>	
Kent & Stanley Co., Providence, R. I. . . . .	24d, 25	Brethauer Watch and Jewelry Co., Chicago, Ill. . . . .	31	Potter, W. K., Providence, R. I. . . . .	31
<b>Clocks, French, English and American.</b>		Myers, S. F. & Co., 48 Maiden Lane, N. Y. . . . .	48	<b>Tool Manufacturers and Dealers.</b>	
Jacques, Chas. Clock Co., 22 Cortlandt St., N. Y. . . . .	48	Oppenheimer Bros. & Veith, 35 Maiden Lane, N. Y. . . . .	24	Allen, Benj. & Co., Chicago, Ill. . . . .	16-33
<b>Cut Glass.</b>		Sproehhle, F. M. & Co., Chicago, Ill. . . . .	35	American Watch Tool Co., Waltham, Mass. . . . .	40
Clark, T. B. & Co., 860 Broadway, N. Y. . . . .	42	<b>Musical Boxes.</b>		Moseley & Co., Elgin, Ill. . . . .	33
<b>Diamond &amp; Precious Stone Importers.</b>		Cuendet, E. L., 21 John St., N. Y. . . . .	16	Oliver, W. W., Buffalo, N. Y. . . . .	48
Disselkoben, John N., 19 E. 16th St., N. Y. . . . .	24c	Jacot & Son, 39 Union Square, N. Y. . . . .	48	Swigart, E. & J., 101 W. 5th St., Cincinnati, O. . . . .	33
Falkenau, Oppenheimer & Co., 40 Maiden	48	Wolfe, A., 194 Broadway, N. Y. . . . .	19	<b>Trays.</b>	
Friedlander, R., L. & M., Ltd. 30 Maiden Lane, N. Y. . . . .	46	<b>Ophthalmic College.</b>		Fletcher Mfg Co., 259 W. 27th St., New York. . . . .	19
Hedges, Wm. S. & Co., 170 Broadway, N. Y. . . . .	24b	St. Louis Ophthalmic College, St. Louis, Mo. . . . .	35	<b>Trunks and Traveling Bags.</b>	
Kahn, L. & M. & Co., 172 Broadway, N. Y. . . . .	48	Chicago Ophthalmic College, Chicago, Ill. . . . .	33	Crouch & Fitzgerald, 161 Broadway, N. Y. . . . .	5
Kipling, E. E. 182 Broadway, N. Y. . . . .	48	<b>Optical Goods.</b>		<b>Watch Manufacturers.</b>	
Kipling, R. A., Hays Bldg., N. Y. . . . .	24b	Berger, Albert & Co., 47 Maiden Lane, N. Y. . . . .	5	A. C. Smith Watch Co., 177 Broadway . . . . .	9 20 28
Lorsch, Albert & Co., 37 Maiden Lane, N. Y. . . . .	48	Geneva Optical Co., Chicago, Ills. . . . .	33	Trenton Watch Co., Trenton, N. J. . . . .	32a
Nissen Ludwig & Co., 18 John St. . . . .	24b	Queen & Co., Philadelphia, Pa. . . . .	12	<b>Watch Case Repairers</b>	
Randel, Baremore & Billings, 29 Maiden Lane	24c	Spencer Optical Mfg. Co., 15 Maiden Lane, N. Y. . . . .	37	The Planchamp & Becker Co., Chicago, Ill. . . . .	33
Smith, Alfred H. & Co., 182 Broadway, N. Y. . . . .	24b	<b>Pens, Pencils, etc.,</b>		<b>Watch Importers.</b>	
Tannenbaum, L., & Co., cor. Maiden Lane and Nassau St., N. Y. . . . .	23	Aikin, Lambert & Co., 19 Maiden Lane, N. Y. 8-24b	8	Hyde's, J. E., Sons, 22 Maiden Lane, N. Y. . . . .	44
<b>Diamond Jewelry.</b>		Beaumont, D. W., 17 John St., N. Y. . . . .	8	Racine, Jules, 180 Broadway, New York. . . . .	47
Jeanne, Paul, Bradley Bldg., N. Y. . . . .	8	Diamond Point Pen Co., 7 Astor House' N. Y. . . . .	44	A. Wittnauer, 19 Maiden Lane, N. Y. . . . .	27
Leonhardt & Curran, 44 1/2 Maiden Lane, N. Y. . . . .	16	LeRoy, Fairchild & Co., 3 Maiden Lane. . . . .	9	<b>Watch Keys.</b>	
Sauter, L. & Co., 194 Broadway. . . . .	45	Smith, H. M. & Co., 83 Nassau St. . . . .	46	Clark, A. N., Plainville, Conn. . . . .	48
<b>Diamond Polishing Mills.</b>		<b>Ring Makers.</b>		<b>Watch Repairers.</b>	
Arthur Co., The, 86 John St., New York. . . . .	48	Bowden, J. B. & Co., 192 Broadway, N. Y. . . . .	4	Henry, Peter, Cincinnati, O. . . . .	33
<b>Display-Window.</b>		Bryant, M. B. & Co., 10 Maiden Lane, N. Y. . . . .	14		
Pearce, Frederick, 77-79 John St., N. Y. . . . .	38	Hildreth Mfg. Co., 53 Maiden Lane, N. Y. . . . .	41		
		Princess Ring Co., Hays Bldg., 21-23 Maiden Lane, N. Y. City. . . . .	2		
		Waite, Thresher Co., Providence R. I. . . . .	24c		

## Special Notices.

Rates 75c. per insertion for notices not exceeding 3 lines (25 words); additional words 2 cents each. If answers are to be forwarded, postage stamps must be enclosed. Two insertions, 15 per cent. off; three insertions, 20 per cent. off; four insertions or more, 25 per cent. off. Payable strictly in advance. Display cards on this page will be charged at \$2.00 per inch for first insertion, subject to same discount as above for subsequent insertions.

Under the heading of **Situations Wanted** on this page advertisements will be inserted for One Cent a Word. This offer refers to **Situations Wanted only**. Payable strictly in advance. If answers are to be forwarded, postage must be enclosed.

## Situations Wanted.

Notices under this heading **ONLY** are charged at one cent a word, payable strictly in advance. If answer are to be forwarded, postage must be enclosed.

**BY** an American watchmaker, jeweler and salesman with complete set of tools and eight years' experience. Best reference. Address Reliable, Box 202, Station A, Meriden, Conn.

**SITUATION** wanted by an A1 watchmaker and engraver: sober and reliable; 16 years' experience; A1 reference; have fine set of tools. P. B. L., P. O. Box 412, Winchester, Ill.

**FIRST-CLASS** watchmaker, jeweler and salesman wants position. Young man; single; 12 years' experience. Best of references. Address C. E. Hagy, Abingdon, Va.

**WANTED.**—A steady position by a first-class watchmaker. Twenty years' experience. Have my own tools. Best of references. A. L., care of JEWELERS' CIRCULAR.

**WANTED.**—Position by young man, age 22. Can do clock, watch and jewelry repairing. Four years' experience. Best of references. Box 1084, Meriden, Conn.

**SITUATION** wanted by a young lady in the business department of either watch, jewelry, silver or kindred trades. Several years' experience. First-class references. New York or Newark preferred. Address C. T. M., care of JEWELERS' CIRCULAR.

**SITUATION** wanted by lady stenographer and bookkeeper with Chicago house. Experienced in wholesale jewelry. Address X. Y., care JEWELERS' CIRCULAR, Chicago office, 517 Inter-Ocean Building, Chicago, Ills.

**WANTED.**—A steady position wanted as watchmaker, jeweler and engraver; 12 years' experience; speaks German and English; complete set of tools; can furnish good references; Michigan, Ohio and Indiana preferred. Address J. F. W., Box 540, Marshall, Mich.

**BY** a thoroughly competent and first-class watchmaker, jeweler and salesman; do fair engraving; capable of taking charge of retail store; complete set of full nickel tools; single; age 27; no bad habits; want a good steady job. Address John, care THE JEWELERS' CIRCULAR.

**WANTED.**—Position by practical watchmaker and jeweler, 20 years' experience in store and bench; wages not so much an object as good position; 40 years old; single; good reference. Address James Ferguy, care H. Rempe, Danville, Pa.

**WANTED.**—A position by a graduate of New York Horological Institute; is good watchmaker and script letter engraver; A1 references; own lathes and tools; New York City preferred. Address N. Y. C., care JEWELERS' CIRCULAR.

**WANTED.**—Position by young man, age 22, has had six years' experience as salesman in retail store; good window trimmer; best of references. Address X. G., care JEWELERS' CIRCULAR.

**AN** experienced jeweler, married, German, 36 years of age, seeks a situation preferably in a small city; first class repairer and engraver; sober and industrious. C. F. Keller, Louisville, Ky.

**ENGRAVER.**—Plain and fancy; thoroughly understands repairing and replating silverware; assistant salesman; reference A1. Address W., care JEWELERS' CIRCULAR.

**MANUFACTURING** jeweler and engraver; fair workman; sober and reliable; good references. Address S. C. J., care JEWELERS' CIRCULAR.

## Help Wanted.

**WANTED.**—A good manufacturing jeweler; one that can do repair work, re-enameling, plating, and set stones. Address A. H. Furstnow & Co., Fond du Lac, Wis.

**WANTED.**—First class watchmaker accustomed to complicated chronometers and fine grades of Swiss and American watches; only strictly responsible and competent watchmakers need apply; who is good engraver preferred; state salary wanted; send samples of engraving. Address General Watch Inspector, Northern Pacific, Grand Forks, N. Dakota.

**WANTED.**—First class watchmaker; one able to engrave, with a knowledge of optical work preferred; state age and wages expected. 8 Temple building, Montreal, Que.

**WANTED.**—Letter engravers on silverware. State experience and wages expected. Address B. C., care JEWELERS' CIRCULAR.

## Miscellaneous.

**I BUY JEWELRY STOCKS.**—Manufacturers, jobbers and retailers desiring to dispose of surplus or entire stocks of diamonds, watches and jewelry can find quick cash buyer by addressing Stephen S. Harmon, 1240 Lexington Ave., New York City.

## Business Opportunities.

**PARTNER WANTED.**—In an established jewelry business in State of Illinois, located where crops are good and hard times not felt, doing the best business outside of Chicago. Population 12,000. Capital required about \$8,000; annual cash sales \$35,000. Investigation courted. Best of reference given and required. Prefer young man of some experience. Address F. E. B., care JEWELERS' CIRCULAR.

**YOUNG** man, 27 years old practical watchmaker, good salesman and business correspondent; (English, French and German); has been employed five years in America; wants position as interested employe or partner in retail jewelry store or importer's office; can invest \$2,500; references. Address offers with all details as to salary, interest, security, etc., to L. R., poste restante (general delivery), Geneva, Switzerland.

## For Sale.

**\$500 BUYS** a well paying jewelry business in Illinois with branch agencies and watch club. Absolutely. No competition. Address Snap, JEWELERS' CIRCULAR.

**PAYING** jewelry business in live town established 20 years. No competition. Bench work alone pays \$50 monthly. Clean stock. Ill health reason for selling. Will sell for \$1,500 cash. W. C. Bailey, Winthrop, Me.

**MY** entire stock and fixtures consisting of watches, clocks, jewelry, silverware, showcases, etc.; with or without tools; prices to suit the buyer; must sell at once; best of reason for selling; bench work will average \$18 per week; rent \$8 per month; all modern improvements; plate glass front, brick building, center of business in the city; population about 2,000; rich farming country all around here; eastern Michigan. Address Michigan, care JEWELERS' CIRCULAR.

## A RARE OPPORTUNITY

To Buy at a bargain Fixtures and Lease of a 16 years established Jewelry Store on the leading avenue up town in New York City.

Owner retiring from business wishes to close out his Stock of Diamonds, Watches, Jewelry and Silverware before January 1st.

Sales have averaged the last five years from \$16,000 to \$20,000, and the amount of repairing from \$3,000 to \$4,000 yearly.

Good reference given.  
Address A. A., care Jewelers' Circular.

## FOR SALE.

The entire Plant of H. Muhr's Sons' Factory; one of the most complete in this country will be sold for reasonable price Bids solicited.

**BROAD AND RACE STS.,  
PHILADELPHIA.**

## DIAMOND CUTTING WORKS FOR SALE

12 Mills down-town, most improved, entirely new machinery, good light, could give possession at once. Rent of premises reasonable.

APPLY TO

**THE ARTHUR CO.**

86 John Street, New York.

## 17 Jewel Dueber-Hampden Watches

ARE THE MOST RELIABLE WATCHES MADE.

A FULL LINE OF DUEBER CASES AND HAMPDEN MOVEMENT.

Write for New Price List.

**Brethauer Watch and Jewelry Co.,** Special Agents,  
71 WASHINGTON ST., CHICAGO, ILLS.

SPECIAL SALESMAN OF

**WATCHES, DIAMONDS,**

Bric-a-Brac

and Art Goods

FOR

**Established Jewelers.**

WRITE FOR PARTICULARS.

Communications Strictly Confidential.

References given in all parts of the United States from Retailers and Jobbers.

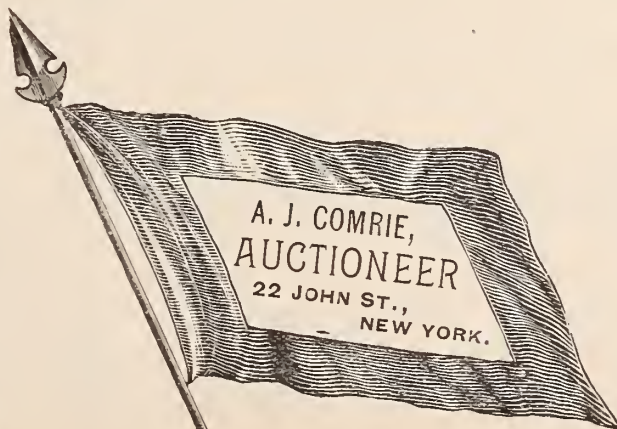

way. With every garment or article that is sold they give a check, which is numbered and dated. On it is printed the foregoing:

This check is a clincher, which is sure to make the recipient feel very kindly toward the house, and, as a matter of fact, he is much less likely to make a complaint than he would be if he did not have the guarantee slip.

#### The Legality of Watch Clubs in Connecticut.

HARTFORD Conn., Nov. 12.—William J. Pierce, a clerk for the Travelers' Insurance Co., was on trial in the police court this morning, charged with violating the lottery laws by managing a sale of gold watches on the weekly club system. Pierce is agent of the Standard Jewelry Co., of Meriden.

The prosecution was instigated by the Connecticut Retail Jewelers' and Opticians' Association, recently organized. Joseph L. Barbour defended Pierce and claimed that under the system there cannot be fraud, as each person obtains full value for his money. Judge Barbour reserved his decision until Wednesday. The case is regarded by jewelers as a test case.

G. A. Sauer, who has been engaged in the jewelry business in Millfintown, Pa., since April, last week sold out to John Sweger. Mr. Sauer has returned to Baltimore, and will hereafter travel for a music house.

Officers from Londonderry, Vt., were in Albany, N. Y., in search of a burglar who cracked a safe in the jewelry store of W. H. Landman, in that place, last Monday night, and stole 20 watches and about 60 rings. The person suspected of the burglary is a man who was in the jewelry store the day before and represented himself as an agent for a safe company. He examined the safe and then went off, promising to return again. The officers describe him as being about 55 years old, 5 feet 8 inches high, grey chin whiskers.

### Grown-Up Toys.

BY ELSIE BEE.

THE taste for frivolities so conspicuous to-day is not without reason. If the history of things could be written it would doubtless be found that interest in trifles tended to preserve the balance whenever the feverish haste of daily life taxed too greatly the energies of men and women. Marie Antoinette playing shepherdess at the Little Trianon had some philosophic basis.

Without these considerations it would be curious enough to find a demure matron seated at a table arranging a farmyard of bronze cows and chickens, and a club man over a counter buying a collection of china or bronze pussies, which he will install in his chambers for the entertainment of his friends.

This new phase which collecting has assumed was introduced through the silver tables. The proper silver table was a low spider legged affair covered with brocade and finished with gold gimp and lace. On these were set forth all sorts of curious or rare small pieces of silver. These silver tables were matters for social rivalry. Conversation immediately began over inspection of the silver table, as in rural communities it depends on the photograph album.

Silver, however, proves more costly, and by no means so amusing as the later and more grotesque phase has assumed. The art, spirit and humor that reside in these miniature travesties of human life to be found in French, German and Italian bronze and china are in fact worthy our higher consideration.

Since the days of Æsop, revived in Lafontaine, the human in animals appeals to almost every member of the human race. On almost any fine day it is possible to see a bank president and a messenger boy alike grinning at a cat orchestra, or a group of monkeys playing cards in some shop window.

The fidelity to nature in form, color and

action in these small pieces gives the dignity of an art to the representation. It is impossible to enumerate the forms they take. The figures are all detached and their attitudes suggest something of the proper grouping, but this can be varied and different humorous combinations can be worked out.

Monkeys, cats, dogs and horses are the favorite animals and playing musical instruments, waltzing, flirting, nursing babies are their favorite occupations. Some of the most amusing pieces are single; for example a cat seeing its master's hunting suit hanging on a rack, is taking revenge for his preference for dogs by beating the coat with a stick. The cat's earnestness would make a philosopher laugh.

The race course is figured in every shape with horses and jockeys. There are other more graceful and pastoral scenes with sheep, cows, chickens and horses together with such details as ploughs, stiles, old gates, hedges, watering troughs, etc. Such groups demand a separate table, or corner of a mantelpiece and sufficiently detached from other ornaments.

Animals are not the only form these trifles take. There are Oriental figures, bazaar keepers looking out from their windows, squatting groups making coffee with all their pretty implements and an Oriental square on which to group them. There are groups of all nations not forgetting the negro, all conceived with reference to some central motive. Various trades are represented, the varieties being the shoemaker, the porter and the bellows mender. There are, of course, convivial groups with costumed serving maids and German beer jerkers. There is, of course, a sufficiency of ballet girls, bathers, horsewomen dressed and undressed in the last touch of French fashion.

The politer accomplishments and the sentiments have their expression. These are chiefly in china and come from Germany while the bronzes are from France and Austria. Shepherdesses and their swains, maidens coquetting with love's flirtations among Watteau groups, sedan chairs with powdered dame inside and gallants at the windows, musical parties, are all to be found in Dresden ware. Other sorts of German wares have domestic groups with babies beruffled in fine laces wonderfully simulated in china.

The blue and white Delft is more devoted to domestic scenes, cows and milkmaids, mothers and their children. Italy produces beggars, peasants, Savoyards, street arabs.

Altogether it is an interesting turn in human interest. Now that the holidays are approaching, the shops are devoting more and more of their space to these amusing travesties of human experience. The jeweler has found in them a new method of beguiling his trade. In five well known houses different bronze groups of the most grotesque sort were found in the midst of a display of bursting suns and other heavenly bodies.

## "BROWNIES"

Have become very popular through the medium of the "Ladies' Home Journal" and the "St. Nicholas." The following illustration is a reproduction of a Souvenir Coffee Spoon designed by a Louisville lady and controlled by



WM. KENDRICK'S SONS, Jewelers,

336 4th Avenue, Louisville, Ky.

PRICES: Coffee Spoon, Plain, \$2.00; Gilt Bowl, \$2.25; all Gilt, \$2.50. Discount to Jewelry Trade. SPECIAL: Upon receipt of \$1.50 Spoon will be sent as sample.



**The Latest Patents.**

ISSUE OF OCT. 30, 1894.

**528,155. LENS FOR OPTICAL PURPOSES.** CARL P. GOERZ, Schöneberg and EMIL VON HÖEGH, Wilmersdorf, Germany.—Filed Feb. 11, 1893. Serial No. 461,972. (No model.)



In an objective, a compound lens consisting of three single lenses, the outer ones of which have a greater and less refractive power respectively than the intermediate lens, said intermediate lens having its surfaces curved in opposite directions and said outer lenses having their outer surfaces curved in the same direction.

**528,186. MATCH-BOX.** MAX STRAKOSCH, New York, N. Y., assignors of two-thirds to Frank Wolf and Leopold Salzer, same place.—Filed Nov. 7, 1893. Serial No. 490,257. (No model.)

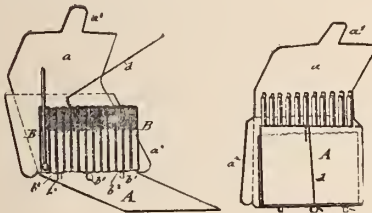

A match-box composed of a wrapper or case provided with a closing top-flap, and side-flaps, a corrugated partition having an igniting surface at each side of and secured to the wrapper, and a covering or finishing wrapper applied to the body of said main wrapper, and adapted to form a pocket for the tongue of the closing top-flap.

**528,197. EAR-RING.** GILBERT T. WOGLOM, New York, N. Y.—Filed Nov. 7, 1893. Serial No. 490,328. (No model.)



The combination with an ear-wire of a loop-shaped lug extending upward from the lower portion of the said ear-wire, to rest against the ear-lobe and by its pressure prevent the tilting of the ear-ring.

**528,207. WATCHCASE-SPRING.** CHARLES NOBS, Newark, N. J. Filed Dec. 15, 1893. Serial No. 493,728. (No model.)

A watch case spring provided with a tongue formed on the side thereof, said tongue being bent back and out to form a centrally arranged post on



the back of the spring, in combination with a sectional piece or backing provided with a slot or opening extending entirely through said piece or backing, whereby said piece or backing can be arranged upon said post and on the back of said spring.

**528,211. SLOW MOTION ATTACHMENT FOR MICROSCOPES.** HIRAM G. SEDGWICK, Nashville, Tenn.—Filed Feb. 10, 1894. Serial No. 499,783. (No model.)

**528,223. WORKMAN'S TIME-RECORDER.** DANIEL M. COOPER, Rochester, N. Y.—Filed May 14, 1894. Serial No. 511,223. (No model.)

**528,452. MEANS FOR ATTACHING KNIVES TO THEIR HANDLES.** JOSEPH WESTBY, Sheffield, and JOSEPH WHITFIELD, Menston, Wharfedale, England. Filed Oct. 16, 1893. Serial No. 488,319 (Model.) Patented in England, May 18, 1893, No. 9,977.

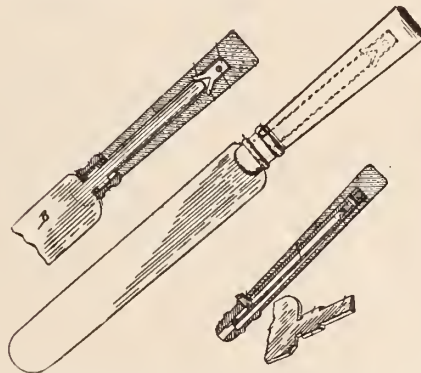

A knife blade provided with a tang having two lateral shoulders beveled on their inner ends, in combination with a knife handle which receives the said tang and a spring catch fastened to the said handle within the socket of the same and provided with raised lugs which are rounded for contact with the beveled ends of the said shoulders but adapted to hold the tang and blade in place when they spring into their former position after the shoulders are pressed in beyond them.

**528,469. DEVICE FOR HOLDING COLLARS OR CUFFS ON SHIRTS.** ADOLPH FEINER and THOMAS G. SEXTON, Lexington, Ky. Filed Feb. 10, 1894. Serial No. 499,822. (No model.)

A device for attaching collars or cuffs to shirts comprising a U shaped frame having two legs, 1 and 2, the front leg 1 being slotted as at *a*, a U-shaped collar or cuff holder made of resilient material and provided with roughened holding arms, mounted in said frame, a bent lever pivoted to said front leg pro-

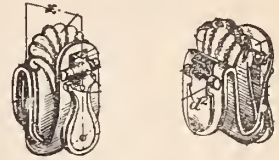

jecting into said slot *a* and adapted to press said holding arms together, an extension *A'* integral with said rear leg 2, bent over as shown, and slotted as at *a'*; a bent lever *D* pivoted in said slot, and a spring mounted on the inside of said extension and adapted to be pressed forward by said lever.

**DESIGN 23,747. SPOON, &C. HENRY J. ROBIN-**

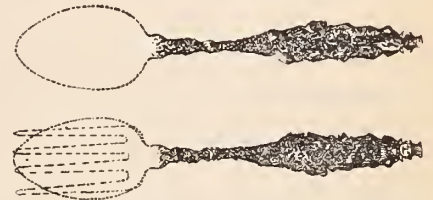

SON, Washington, D. C., assignor to Rieman & Dawson, same place. Filed Sept. 28, 1894. Serial No. 524,404. Term of patent 7 years.

**TRADEMARK 25,414. MEDALS.** GEORGE B. SOLEY, Philadelphia, Pa. Filed Sept. 18, 1894.



*Essential feature.*—The representation of Independence Hall. Used since November 1, 1887.

**TRADEMARK 25,415. MEDALS.** GEORGE B. SOLEY, Philadelphia, Pa. Filed Sept. 18, 1894.



*Essential feature.*—A representation of the Liberty Bell. Used since November 1, 1887.

ARE YOU PUSHING THE SALE OF

**TRENTON MOVEMENTS?**

IF NOT, WHY NOT?

For intrinsic value and great merits combined, with **LOWNESS of PRICE**, they far surpass any movements ever placed on the market.

A sample line will thoroughly convince you that it will be to your advantage to handle them extensively.



6 SIZE, 7 JEWELS.



16 SIZE, 16 JEWELS.

INSIST UPON HAVING THEM.

**TRENTON WATCH CO.,**  
TRENTON, N. J.

TRADEMARK 25,416. MEDALS. GEORGE B. SOLEY, Philadelphia, Pa. Filed Sept. 18, 1894.



*Essential feature.*—The representation of a cross and crown. Used since April 1, 1891.

ISSUE OF NOVEMBER 6, 1894.

528,528. SPECTACLES OR EYEGLASSES. JOHN L. BORSCH, Philadelphia, Pa.—Filed June 2, 1894. Serial No. 513,289. (No model.)



The combination with a spectacle or eyeglass lens, of a clasp B, secured by a screw to the same, and a four-armed cushion C, set between the lens frame and the glass so as to embrace and protect both the edge and the faces of the lens.

528,538. WATCHMAKER'S CALIPERS. GEORGE B. FARRELL, East Las Vegas, N. Mex.—Filed April 15, 1893. Serial No. 470,507. (No model.)

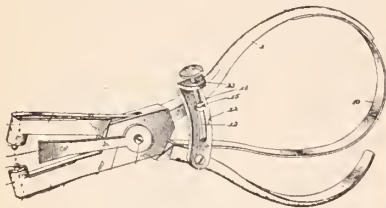

The combination with a tool having pivoted jaws and provided with handles, a segmental plate secured at one end to one of the handles and having intermediate of its ends a longitudinal slot, and provided at its other end with an outwardly extending flange or seat 13 arranged at right angles to the body of the plate and provided with a threaded opening, a headed stud projecting outward from the other handle and arranged in the slot of the plate, and a set screw mounted in the threaded opening of the flange or seat 13 and arranged to engage the head of said stud.

528,587. APPARATUS FOR ELECTRODE-POSITION. HENRY L. BRIDGMAN, Blue

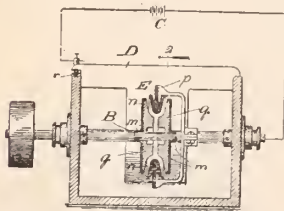

Island, Ill. Filed Oct. 3, 1893. Serial No. 487,115. (No model.)

528,651. FOUNTAIN-PEN. HARRY L. BRA-

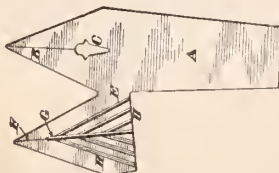

HAM, Cincinnati, Ohio. Filed Aug. 2, 1894. Serial No. 519,232. (No model.)

528,678. ELECTRIC ALARM - CLOCK. MICHAEL McDONNELL, New Bedford, Mass. Filed May 29, 1894. Serial No. 512,856. (No model.)

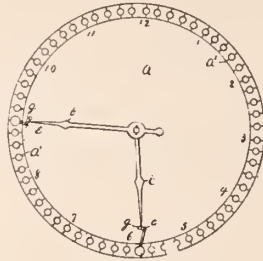

In an electric alarm clock, adjustable contact devices, consisting of the metallic posts *d d'*, having an arm *e*, bearing in its outer extremity a flat spring *g*, adapted to yield to the slight pressure of the hand of the clock in whose path it is adjusted.

528,715. CUFF - BUTTON OR STUD. CHARLES C. CHAMPENOIS, Newark, N. J. Filed June 5, 1894. Serial No. 513,597. (No model.)



The herein described button or stud, comprising therein a casing *c* and a disk *e* secured therein provided with a hub having a screw-threaded hole, a perforated disk in said casing, a pair of springs *d* and *d'* having spring-arms *d<sup>2</sup>* and *d<sup>3</sup>* respectively spurs *d<sup>4</sup>* on each spring resting against curved portions *d<sup>5</sup>* of said springs, a screw post adapted to be screwed into said hub to separate said spring arms *d<sup>2</sup>* and *d<sup>3</sup>* and slots on the opposite sides of said post at or near the screw threaded end thereof, adapted to engage with said spring-arms and cause the parts of the button to be locked.

528,716. OCULIST'S TESTING-FRAME. JOSEPH H. E. DE CELLES, Southbridge, Mass., assignor to the American Optical Company, same place.—Filed Jan. 3, 1894. Serial No. 495,512. (No model.)

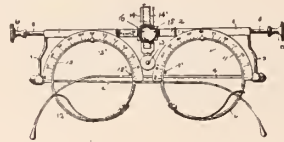

An oculist's testing frame, consisting of two flat bars with their outer ends bent rearwardly and downwardly to form downwardly extending arms to the lower ends of which are jointed the temples, and said temples, and the inner ends of said bars overlapping and adapted to slide longitudinally on each other to lengthen or shorten the frame, and a lens holding frame attached to each and to move therewith, to adjust simultaneously the lens holding frames and the temples.

527,717. OCULIST'S TESTING FRAME. JOSEPH H. E. DE CELLES, Southbridge, Mass.,

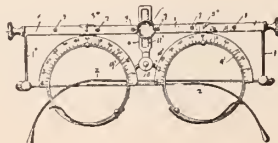

assignor to the American Optical Company, same place.—Filed Jan. 3, 1894. Serial No. 495,513. (No model.)

528,739. MUSICAL CLOCK. HENRY W. PORTER, Forestville, Conn., assignor of one-half to Frederick N. Manross, same place.—Filed Nov. 27, 1893. Serial No. 492,105. (No model.)

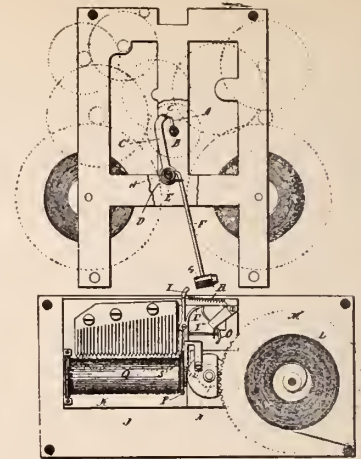

528,790. ALARM FOR WATCHES. JOHN W. NUNAMAKER, Chicago, Ill.—Filed June 29, 1894. Serial No. 516,113. (No model.)



DESIGNS 23,755, 23,760. SCARF - PINS. GEORGE F. GREENE, Providence, R. I.—Filed



Oct 6, 1894. Serial Nos. 525,163, 525,164, 525,166, 525,163, 525,165, 525,167. Term of patent 3 1/2 years.

DESIGN 23,761. GLASS VESSEL. THOMAS

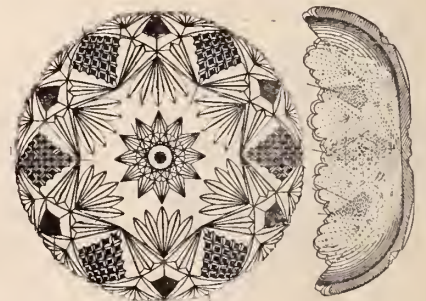

SINGLETON, Jr., New Bedford, Mass., assignor to the Pairpont Manufacturing Company, same place.—Filed Oct. 9, 1894. Serial No. 525,434. Term of patent 7 years.



**Canada and the Provinces.**

STATE OF TRADE.

Business has been quiet in Toronto of late but a good average holiday trade is anticipated with a demand more especially for cheap sterling silver novelties and fancy jewelry. Trade is better in the eastern section than the west where the depression caused by the low prices for grain is seriously felt. A good lumbering season is anticipated and business is considerably more buoyant in the lumbering districts than in the purely agricultural sections.

Inquiries among the Toronto wholesale houses indicate that sales of diamonds have considerably increased since the imposition of a higher duty on diamonds entering the United States, presumably on account of sales to American visitors. P. W. Ellis, of P. W. Ellis & Co., states that his anticipations of the effect of the change have been fully realized, their sales of diamonds having increased fully 20 per cent. since the United States duty was put on.

J. Luke, jeweler, Ingersoll, Ont., has sold out to Wm. Gibson.

G. Kleiser, jeweler, of Toronto, has been visiting in Nova Scotia.

R. W. Woodruff, Winnipeg, Man., paid Toronto a visit last week.

F. Saunders, Winnipeg, Man., is selling out and will leave the city.

W. A. Fenwick, late of Toronto, has opened a jewelry business in Guelph.

E. A. Woodmancy, representing Potter & Buffinton, Providence, R. I., was in Toronto last week.

Harper Allen's jewelry establishment, Port Elgin, N. B., was robbed last week of \$300 worth of goods.

George Chillas, Montreal, representing the Pairpoint Mfg. Co. was registered last week at the Rossin, Toronto.

E. F. Davis, jeweler, Mitchell, Ont., has bought out the book and fancy goods store of Robbins Bros., of that place.

W. Gibson, son of Postmaster Gibson, Ingersoll, Ont., has purchased the jewelry business of L. H. Luke, of that town.

C. H. A. Grant, of the Montreal Watch Case Co., and M. Schwob, of Schwob Bros., Montreal, were in Toronto last week.

Charles Robinson, late of the Sheffield House, one of the best known jewelers of Toronto, has accepted a position with P. W. Ellis & Co.

W. J. Harrison, representing A. H. Dewdney & Bro., Toronto, has started on a business trip to the eastern provinces. He will be absent until Christmas.

R. L. Meadows, formerly with E. & A. Gunther, and lately manager of the Winnipeg Jewelry Co., died on the 2d inst. He was about 30 years of age and unmarried.

The Toronto Jewel Case Co., Toronto, in order to enlarge their manufacturing facilities and accommodate additional plant

have removed to more commodious premises at 11 Wellington St. East.

J. F. Herlim, Wolfsville, N. S., is exhibiting in his window a collection of amethysts obtained at Blomidon, a few miles from the town of Wolfsville, cut into gems suitable for setting. The lapidary work was done in Canada.

A. J. C. MacKenzie, a jeweler who did business on Buckingham St., Halifax, N. S., over 30 years ago, is reported to have died recently in Amethyst, Col., worth considerable property, and inquiries are being made for his heirs in Halifax.

W. C. Gibson, jeweler, St. John, N. B., is offering to compromise at 35 per cent. at three and six months secured. His liabilities are \$5,300. He settled his debts in 1876 by paying one-half what he owed. The business has been running for about 25 years.

**Jeweler Drinkwater Gets Himself Into a Predicament.**

YOUNGSTOWN, O., Nov. 10.—E. H. Drinkwater, a jeweler of Toledo, had himself appointed a constable and came here to-day to collect a small bill for jewelry from Mr. and Mrs. L. A. Haulters, proprietors of Turkish bath parlors. When they did not settle he attempted to arrest them and take them to Toledo, but was prevented by a writ of habeas corpus.

A \$10,000 damage suit was immediately brought against him for false arrest.

**HOLIDAY COLLECTION FOR THE TRADE.**

**ORDER ONE.**

**NOVELTIES**

... FOR THE ...

**JEWELRY • TRADE.**



THE FOSTER PATTERN.



RICHFIELD PATTERN.



THE ROSE PATTERN.

Our \$75 assortments are a Specialty and form a complete collection.

**P. H. LEONARD, 76 & 78 Reade Street, NEW YORK.**

OF EMPIRE WESTWARD TAKES ITS WAY!

# WESTERN SUPPLEMENT OF THE JEWELERS' CIRCULAR

**Chicago Office: Room 517, Inter-Ocean Building.**

VOL. XXIX.

CHICAGO, WEDNESDAY, NOV. 14, 1894.

No. 16.

## Chicago Notes.

### TRADE CONDITIONS.

Trade was unsatisfactory last week. The snows and rains of the past week have tended to retard purchasers and the elections are of too recent date to show a reaction in favor of business houses. A satisfactory change is looked for the present week, and the future is regarded as full of encouragement.

H. F. Hahn returned from New York in time to cast his vote.

C. R. Raymond, Omaha, Neb., stopped off to see business friends here on his return home from New York.

C. E. Patterson, Towle Mfg. Co., came in from his trip, saw the handsome new lines, and went forth to Indiana to conquer.

V. E. Rukgaber is the title of the successor to Rukgaber & Crane, 280 E. 55th St., and the store on 53d St. will be discontinued. Mr. Crane has entered business in Mt. Pleasant, Iowa.

C. M. Welsh, Plymouth, Ind., is in Chicago attending Mrs. Welsh, who is under treatment here. Wednesday night it was not thought Mrs. Welsh could survive twenty-four hours.

The Maltby, Stevens & Curtis Co., Wallingford, Conn., have sent G. A. Webster, 44 Madison St., who carries their line here, a new Brownie child's set that combines the popularity of Brownie designs with low price.

"The factory is running full time and working hard to keep abreast of orders" is the report of Manager Loeb, of the Chicago office of the Wadsworth Watch Case Co. Mr. Loeb has returned from a visit to the factory.

Mr. and Mrs. G. W. Marquardt, Jr., are entertaining at their home a very popular young gentleman who arrived at the house Nov. 4. His last name is Marquardt and on arrival weighed nine pounds. He is Mr. and Mrs. Marquardt's first born.

Bixby & Hamilton, Danville, Ill., have

bought the stock of Lion & Kylling, of that city and will continue the business at the old stand. Mr. Bixby is an old-time jeweler of Danville and was in the employ of Lion & Kylling as watchmaker. Mr. Hamilton was connected with the Chicago & Eastern Illinois Railroad, for which the new firm have been appointed watch inspectors at Danville.

The regular monthly meeting of the Chicago Jewelers' Association was held at their rooms, Nov. 7. The committee on holidays reported favorably as to closing places of business all day on Thanksgiving, Christmas, New Year, Washington's Birthday, Decoration Day, and 4th of July; closing at 5.30 P. M. from Jan. 15 to Sept. 1, and closing at 12 noon Saturdays from April 1 to Sept. 1. No other important action came before the association.

A clew has been found that may possibly result in unearthing the robbers who held up George W. Brethauer, of the Brethauer Watch & Jewelry Co., and looted the store, but particulars are carefully withheld from the press through fear of publication interfering with the work of the city detectives on the case. A watch case has been located, but further details are denied reporters. Mr. Brethauer is completing his inventory, the checking up of memorandum goods having taken considerable time, and thinks his loss will not exceed \$2,000. This will have no serious effect on his business.

Despite the election buyers were fairly numerous in Chicago the past week, among whom were noticed: Harry Birely, Oshkosh, Wis.; Lyon & Scott, Ottumwa, Ia.; C. S. Corey, Lehigh, Ia.; Wm. Conley, Cresco, Ia.; J. J. Lowry, Cresco, Ia.; Mr. Thatcher, Milwaukee, Wis.; Frank Foote, Lake Mills, Wis.; H. B. Conyers, Chillecothe, Ill.; A. Helfrich, Burlington, Wis.; J. R. Schneider, Evanston, Ill.; Schmeltzer & Derleth, Centralia, Ill.; E. F. Schafer, Chesterton, Ind.; Smyth & Lawrence, Elgin, Ill.; J. N. Schaefer, Milwaukee, Wis.; Clarence Vail, Ransom, Ill.; R. E. Winter, Fort Sheridan, Ill.; W. P. Yeoman, Waukegan, Ill.; J. W. Burkett, Arlington Heights, Ill.; Baker & Son, Fay-

ette, Ia.; E. B. Boyne, Jr., Delton, Mich.; D. S. Bander, Elburn, Ill.; F. B. Crane & Co., Mt. Pleasant, Ia.; C. S. Dustin, Stillman Valley, Ill.; W. W. Denny, Aurora, Ill.; C. E. Dodge, Walnut, Ill.; Erickson & Newhouse, Mabel, Minn.; R. H. Haines, Indianapolis, Ind.; J. J. Heath, Lansing, Mich.; T. B. Holderness, Batavia, Ill.; J. F. Ingalls, Waukegan, Ill.; H. Laederach, Hammond, Ind.; L. Luchtemeyer, Blue Island; M. B. Messler, Canton, Ill.; W. I. McDonald & Co., Highmore, S. D.; Jos. Okoniewski, Milwaukee, Wis.; C. J. Peterson, St. Charles, Ill.; Irvin Runyeon, Redlands, Cal.

## Pittsburgh.

Maurice Baer is in New York, on a six weeks' visit.

William Harrison, formerly with R. L. McWatty & Co., is now with G. B. Barrett & Co.

Charles Lohman, a young jeweler of this city, is now with J. P. Steinman, Federal St., Allegheny.

James R. Brown, with G. B. Barrett & Co., has returned from a successful trip through Ohio.

C. C. Will & Co. have removed to their new quarters on Smithfield St., and have made a marked change for the better. The new rooms are larger and much lighter.

Some well known jewelers who visited Pittsburgh last week were: J. B. Bruce, Burgettstown; C. W. Collings, Niles, Ohio; E. H. Kennerdell, Tarentum; H. C. Morrison, Mt. Pleasant; Frank Worrell, Washington, Pa.; E. Kaiser, Brownville; R. Merrill, Jeannette; C. L. Clark, Blairsville; and Loy Hanna, New Castle.

Niel Kunkel, Oregon, Mo., has sold out to Jas. Payne.

O. P. Ragan, Ridgeway, Mo., will open a jewelry store in Grant City, Mo.

W. G. Green, of Saratoga, N. Y. and Rutland, Vt., will open a jewelry store on Glen St., Glens Falls, N. Y., in the store recently vacated by C. A. Hovey.

# LOOK AT THESE PRICES!

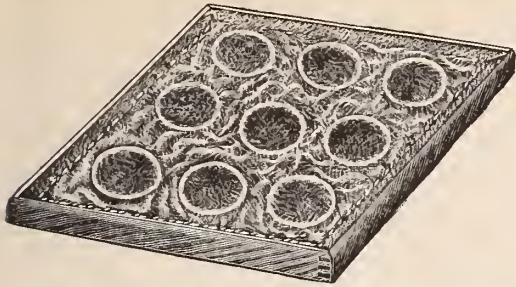

Show Case Trays with Solid Walnut Frames lined with Fine Red Silk Plush, with Old Gold Border, and made to stack one on top of the other. Size, 11 3/4 x 11 3/4.

For Gents' Watches, each . . . . . \$1.25  
For Ladies' Watches, each, . . . . . \$1.25  
For Rings, each . \$1.25. For Chains, each, . \$1.25  
For Charms, ea., \$1.25, for Card Jewelry, plain, ea., 80c.

Subject to the usual discount for cash.

## CHRISTMAS IS COMING.

Make your Stock Attractive and Fresh. It does not cost much and will add largely to your SALES.

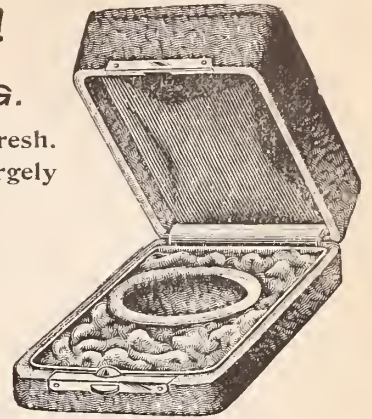

FINE PLUSH BOXES.

## BENJ. ALLEN & Co.,

141 & 143 State St.,

CHICAGO, ILL.

WATCHES, CLOCKS,  
DIAMONDS,  
SILVERWARE  
and JEWELRY.

For Gents' Watches, per dozen, \$3.00  
For Rings, per dozen, . . . . . \$2.00  
For Six Tea Spoons, per dozen, \$9.00  
For Child's Set, per dozen, . . . \$9.00  
For Sugar Shell, per dozen . . \$9.00  
For Ladies' Watches, per dozen, \$3.00  
For Ear Drops, per dozen, . . . \$3.50  
For Six Table Spoons, per dozen, \$15.00  
For Six Coffee Spoons, per doz., \$15.00  
For Butter Knife, per dozen, . . \$9.00

Subject to the usual discount for cash.

### PARSONS : SCHOOL FOR WATCHMAKERS, PEORIA, - - - ILL.

Send for Circular and Terms

PARSONS & CO.

### THE PLANCHAMP & BECKER CO.

Makers and Repairers of

### WATCH CASES, Gold and Silver Plating —

— of Watch Cases a Specialty.  
UNEXCELLED FACILITIES.

63 and 65 East Washington St., Chicago.

EST. 1870. DR. PETER HENRY  
SPECIALIST IN  
Watch Case Diseases



Key Winders changed to Stem Winders

Hunting Case changed to O.S

English Case changed to fit American movements.

Can be cured at  
53  
LONGWORTH ST.,  
Cincinnati, Ohio.

### GENEVA OPTICAL CO., CHICAGO.

CATALOGUES.

- PART 1—General Catalogue of Optical Goods.
- " 2—Microscopes and Accessories.
- " 3—Photographic Cameras, Stocks and Supplies.
- " 4—Thermometers, Barometers and Meteorological Instruments.

**PRESCRIPTION WORK** Made with Promptness and Accuracy.

**OCULISTS' or OPTICIANS' OUTFITS.** Trial Cases, Ophthalmoscopes, Lens Measures.

CORRESPONDENCE SOLICITED.

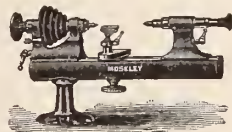

One of the best of the very best.

QUALITY IS THE STANDARD OF VALUE FOR WHICH WE COMPETE

"THE MOSELEY."

"A Bread Winner" for the watchmaker. We furnish you good lathes and chucks, while the other fellow furnishes the wind.

MOSELEY & CO., Elgin, Ill.



No. 2 Moseley Wire Chuck has length, strength, accuracy.

WRITE FOR NEW CATALOGUE.

## Chicago Watchmakers' Institute,

SUITE, 913 A MASONIC TEMPLE, Our New and Enlarged Quarters.

A Modern Trade School for the Watchmaker, Jeweler and Engraver.

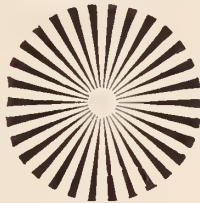

### OPTICIANS' SCHOOL.

If you want a GOOD ROOF over your head, come to our school. We want EARNEST STUDENTS, leave the rest to us, we do not want diploma hunters.

The Chicago Ophthalmic College and Hospital,

H. M. MARTIN M. D., PRESIDENT. 607 VAN BUREN ST., CHICAGO  
Being the oldest and most favorably known College of Theoretical and Applied Ophthalmic Optics in America, having more thoroughly qualified opticians in the field than all other so-called schools combined.

## E. & J. SWIGART, JOBBER OF TOOLS & MATERIALS.

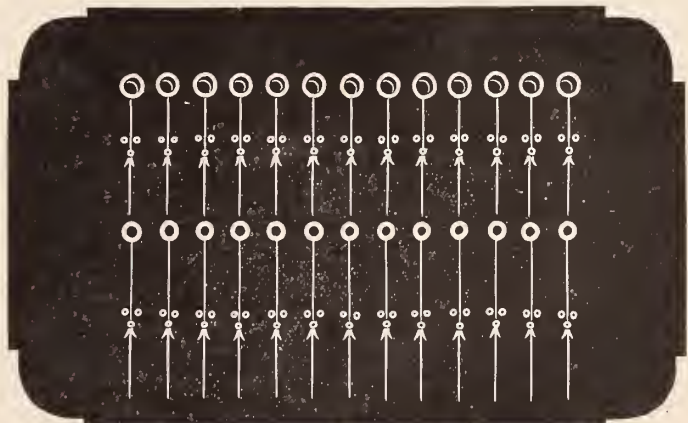

14 K. Gold Watch Hands. QUALITY WARRANTED.

The following Sizes in Stock.

18 Size, Waltham, S. W.	Price per doz. pair, \$7.50	18 Size, Elgin, S. W.	Price per doz. pair, \$6.00
16 " " " Htg.	" " " 7.50	16 " " " "	" " " 7.50
16 " " " P. S.	" " " 7.50	16 " " " Int.	" " " 7.50
6 " " " "	" " " 7.50	6 " " " S. W.	" " " 6.00
0 " " " "	" " " 6.00	0 " " " "	" " " 6.00

14 K. Seconds to match, - - - Price per doz., \$2.50

Send us your Material Orders, if you want good attention and prompt service.

101 WEST 5TH ST., CINCINNATI, O.

### Indianapolis.

E. T. Jordan, Harmony, Ind., was in the city last week buying stock.

Wm. T. Marcy is repainting the exterior of his store in black and gold.

The engagement of Norbert Gunzburger, of New York, and Miss Delia Rosenthal, of this city is announced.

H. M. Tourney, Bloomington, Ind., has recently taken a position as watchmaker with Wm. J. Eisele.

Ill health has obliged W. F. Harmon to give up work at the bench and to seek a change of climate in Tacoma, Wash.

Oscar Daringer is back from a trip through Illinois in the interests of the material house of Nichols, Pee & Co. He reports trade greatly stimulated by the fine corn crops.

Julius C. Walk & Son, of this city, have offered a beautiful silver cup to the individual or firm receiving the largest number of first premiums during the November Chrysanthemum Show.

In a series of articles the business houses in the retail portion of the city, *The Sentinel* mentioned William T. Burns, the oldest jeweler on Indiana Ave., and M. T. Campbell, the oldest jeweler on Massachusetts Ave.

Sam S. Goldsberry, formerly watchmaker for Dyer & Matsumoto, has taken a similar position with Jas. N. Mayhew, and Alfred F. Lick has given up his repair shop on

Indiana Ave., and is now watchmaker for Dyer & Matsumoto.

### St. Joseph.

J. C. Baldwin was married last week to Miss M. E. Lea, of this city.

Louis Burnett & Co., Severance, Kan., have moved their jewelry store to the bank building, formerly occupied by Banker B. F. Harker.

R. U. Hendrick is at his store again attending to business. Samuel Hewitz, for many years with Albrecht & Huber and R. U. Hendrick, has accepted a position with Louis Burnett & Co.

### Minneapolis and St. Paul.

F. D. Day, Duluth, Minn., has satisfied a mortgage for \$1,500.

Karl Rosell has opened a watch repairing establishment in North Branch, Minn.

Simon Jacobs, St. Paul, made a voluntary assignment Nov. 2d to Ed. Schurmeier. The liabilities and assets are not given.

A. H. Simon, St. Paul, has started an auction sale to reduce his large stock. Louis Dodd and H. F. Borroughs are the auctioneers.

Col. Dawson, a well-known jewelry auctioneer, is engaged by A. S. Weller, St. Paul, to manage and conduct daily auction sales in order to reduce surplus stock.

Jobbing trade in the Twin Cities is at present enjoying quite a boom. The firms

are working their forces night and Sundays to keep up with orders.

Emil T. Steinhaus, a watchmaker, has been in Minneapolis purchasing a stock of goods and store fixtures. He has opened a store in White, S. Dak.

Out-of-town jewelers visiting the Twin Cities recently: A. Anderson, Litchfield, Minn.; Mr. Day, Day & Nicholson, Worthington, Minn.; Jacob Stange, Kenyon, Minn.; L. J. Korstadt, Zumbrota, Minn.; Karl Rosell, North Branch, Minn.; E. T. Steinhaus, White, S. Dak.

B. Edelstein, manager of a jewelry store at 103 Nicollet Ave., Minneapolis, was fined \$5 for assaulting W. P. Harmon. Edelstein became incensed at Harmon after he had shown Harmon about 20 mouth organs and the latter was about to depart without making a purchase. Edelstein thought he would help Mr. Harmon out of the place, and he paid the above fine for doing so.

E. Lieberman and James Conner were arrested a few days ago in Minneapolis for working the yellow watch game upon O. M. Schow. Lieberman keeps the place on High St. where the game was played, and Conner, it is alleged, is an old time plugger. Schow claims that he purchased a watch for \$10 and found afterwards that it was fictitious goods and worth only \$2.50. Lieberman was released upon his own recognizance, and Conner was put under \$25 bail.

# Now IS THE TIME . . .

To look over your old style and unsalable jewelry, old plated jewelry, filings, sweeps, etc.

You want to put your stock in good shape for the holidays. The question is:

“Where shall I send my old gold and silver?”

Remember, that we pay 4c. per kt. for Gold and Highest Market

## Prices for Old Silver.

There is a well known maxim that “Experience makes perfect.” To accurately test and value a lot of old gold, etc., the requisite experience is absolutely necessary. Being the largest buyers of old gold and silver in the country, and having the exclusive patronage of the majority of the jewelers in the United States and Canada, we can guarantee to the trade accuracy in valuation and

**PROMPT AND HONEST RETURNS.**

**OUR PLAN**

Immediately upon receipt of shipment we will remit by cash or draft (as desired). If our offer should not prove satisfactory, we will return consignment in exactly same condition as received, and pay all charges. By this arrangement you are absolutely safe, as it is no sale unless our offer should prove satisfactory, and you run no more chances than if you were disposing of same right over your counter.

**GOLDSMITH BROS.,**

Mention the Jewelers' Circular.

Gold, Silver and Platinum Refiners and Assayers,

**FREE**—Send for our **LITTLE BOOK** giving pointers on preparing acids, testing and buying gold, etc., mailed free on application.

**63 & 65 Washington St., Chicago, Ill.**

**San Francisco.**

**TRADE CONDITIONS.**

The wholesale houses report trade to be in a spasmodic condition, but on the whole looking up better. Elections cut a considerable figure in business as most of the country customers waited till after election day before coming to town.

George Jordan, San Bernardino, Cal., has been in town.

O. Zitka, a member of the Standard Jewelry Co., was married last week.

Hampton S. Field, of Hammersmith & Field, has been enjoying a vacation in Santa Cruz.

Walter Green, of Carrau & Green, has arrived home from an extended trip in Europe.

J. A. Watson, auctioneer, has returned from Marysville, Cal., where he conducted a sale for Peter Engle.

Roland F. Allen has returned from a successful trip through southern California for the California Jewelry Co.

S. C. Eppenstein, of Chicago, stopped at the Baldwin last week. Fred. Roth, New York, was registered at the Palace.

George H. Doerr, Spokane, Wash., has been in town. On Nov. 8th he was wedded to a charming young lady of Oakland.

D. E. Mowry, of Kirby, Mowry & Co., Providence, R. I., and Alex. Noack, Sacramento, Cal., were among the latest arrivals in town.

**Pacific Coast Notes.**

E. M. Stanton has re-opened his jewelry store in Riverside, Cal.

Frank A. Conant, Santa Barbara, Cal., has retired from business.

Dupre & Lind have opened a jewelry store in San Luis Obispo, Cal.

Peter Hay, formerly of Sanger, Cal., has opened a store in Fresno, Cal.

Theodore Hansen will open a fine jewelry store at 271 Morrison St., Portland, Ore.

W. Wolf, San José, Cal., is preparing to retire from business the first of the year.

E. D. Foster, jeweler, Norwalk, Cal., has been confined to his home through serious illness.

E. B. Chambers, Santa Barbara, Cal., has just completed the erection of a beautiful residence.

J. H. Bayse is having an auction sale in his Seattle, Wash., establishment, conducted by G. G. J. Watson.

H. M. Funk, formerly a clerk with M. German, in San Diego, Cal., has opened a store of his own in that city.

M. Lessner will open a jewelry and optical establishment at the corner of 13th St. and Broadway, Oakland.

Whitley & Clock have bought out C. C. Hooper, Los Angeles, Cal. Mr. Clock was formerly of Funk & Clock, Seattle, Wash.

H. C. Warner, Fresno, Cal., has moved into the store formerly occupied by Bangle & Hansen, who removed to Tacoma, Wash.

George W. Collis, who was for a number of years with Platt & Harris, Los Angeles, Cal., has opened a store for himself at 58 E. Colorado St., Pasadena, Cal.

W. G. Walz Co. have opened a store at 321 S. Spring St., Los Angeles, Cal. They will deal principally in Mexican jewelry, Mexican opals and shell jewelry.

Maurice Kittredge, Santa Barbara, Cal., has returned from Rochester, N. Y., where he took a course in an optical school, and has taken charge of the optical department of the jewelry store of F. A. Conant.

Wm. J. Westphal, Alameda, Cal., was married last week to Miss Huldah M. Bradley, of East Oakland. The young couple, owing to parental objection to their union, had signed a marriage agreement some time ago, and it was a discovery of this which led to a formal marriage.

**Rockford, Ill.**

The Goodman & Riggs Cutlery Co. have opened a store in this city.

O. G. Dohlman has left on an extended trip through the west for the Rockford Watch Co.

G. D. Parsons opened his Watchmaker's Institute last week. About 50 students were enrolled.

John Ryan, who burglarized a jewelry store in Genoa, pleaded guilty and was sentenced to three years in the penitentiary.

Olaf Olson, jeweler, De Kalb, Ill., was arrested last Monday on the complaint of C. H. Knights & Co., Chicago, who charge him with having obtained \$200 of jewelry on false pretenses. He was held to the criminal court in the sum of \$1,000.

**G. A. WEBSTER**

42 & 44 Madison St., Chicago, Ill.

**Manufacturer,**

AND WESTERN AGENT FOR  
E. G. WEBSTER & SON, of Brooklyn, N. Y.  
A. F. TOWLE & SON CO., of Greenfield, Mass

**BUILT FOR BUSINESS.**

YES, THAT'S WHAT THESE PRICES ARE MADE FOR.

**Elgins Reduced.**

THE FOLLOWING GRADES WILL BE CLOSED OUT AT PRICES QUOTED WHILE THEY LAST.



H. H. TAYLOR.

Compensation Balance, Breguet Hairspring, adjusted, 15 Jewels (4 pairs setting), Patent Regulator, Hunting or Open Face.

- Gilded Movement, . . . . . \$15.00
- Nickel Movement, . . . . . 18.00
- No. 80. Gilt, Hunting, . . . . . 15.00
- No. 76. Gilt, Open Face, . . . . . 15.00
- No. 33. Nickel, Hunting, . . . . . 18.00

**New 17-Jewel Elgin**

18-Size Movement.

B. W. RAYMOND.

Compensation Balance, Breguet Hairspring, adjusted, D. S. Dial, 17 Jewels, (4 pairs settings), Patent Regulator, Hunting or Open Face.

- Gilded Movement, . . . . . \$25.00
- Nickel Movement, . . . . . 32.00
- No. 70. Gilt, Hunting, . . . . . 28.00
- No. 77. Gilt Open Face, . . . . . 28.00
- No. 27. Nickel, Hunting, . . . . . 32.00
- No. 116. Nickel, Open Face . . . . . 32.00

Prices Subject to Catalogue Discounts.

**F. M. SPROEBNLE & CO.,**

CHICAGO.

PUBLISHERS OF **our Salesman**

SEND AND GET OUR CATALOGUE. IT WILL PAY YOUR RENT.



**The St. Louis Ophthalmic College and Hospital**

A SCHOOL OF THEORETICAL AND APPLIED OPHTHALMIC OPTICS.

1655 SOUTH JEFFERSON AVENUE,

N. W. Corner Lafayette Avenue, - - - ST. LOUIS, MO.

For the Announcement and further information, address Ignatz Mayer, M. D., President.

Jeweler John T. Buker wears a handsome gold badge which he won for the best average in a recent tournament of crack shots at St. Louis.

George B. Kelley, manager of the Rockford Silver Plate Co., has purchased the Avery Beach Hotel, at South Haven, Mich. This is one of the most delightful Summer resorts in the State.

The National Cutlery Co. have been much hampered by an accident to their machinery, but the difficulty has been removed and the company will soon have five new machines in operation.

### Detroit.

E. L. Church, Union City, Mich., has opened a jewelry store in that place.

E. Rogers, representing Parks Bros. & Rogers, visited the trade here last week.

W. D. LeRoy, Cedar Springs, Mich., has moved his stock and fixtures to Rockford, Ill.

O. O. Forbush, Chesanning, Mich., has moved his jewelry store into more commodious quarters.

Oscar Marx, of the United States Optical Co., was elected Alderman from the 15th ward by a rousing majority.

G. W. Johnston, 121 Grand River Ave., has moved into handsome quarters at 93 Grand River Ave. in the new Vahy building.

J. F. Steere, of Arnold & Steere, left recently for Providence, R. I. He will return in time to attend to the holiday trade.

G. W. French, Sparta, Mich., has purchased the jewelry stock of T. U. Balkwill, Belding, Mich., and has removed it into the building formerly occupied by Blystone & Gooding, in that place.

H. M. Baxter, Birmingham, and George Chambers, Mt. Clemens, were the only Michigan country jewelers here last week. The jobbers report a dull week and assign the cause to politics. As soon as the agitation is finished, they look for a good business.

Last week burglars attempted to break into the jewelry store of C. W. Mosher, Holly, Mich. W. B. Nicholson, who sleeps in the store, heard them at work in the rear. He grabbed his revolver and fired twice at them and immediately ran down stairs where he found three men. He telephoned for help and held the would-be burglars at bay until it arrived. One of them escaped. The names of the two men who were arrested are James Walker and Thomas Donovan.

Five different jewelry houses of Chicago recently received orders for watches, chains etc., valued at \$400 to be sent C. O. D. to Alvardton, O. Two of the orders bore the names of A. J. Kempton, of Addison, Mich., and the late E. Conant, of Hudson, Mich. The Pacific Express office was broken open and the package stolen. A conference of officers was held in Hudson, Mich., last week to settle upon a plan to apprehend the

thieves. It is suspected that George Cleveland, an escaped prisoner from the Hillsdale jail, had something to do with the job. The names used in ordering the goods indicated a familiarity with the jewelry concerns of Addison and Hudson.

### Cincinnati.

There is to be a new Cincinnati silver plate factory this year.

S. G. Schwab is on the road and reports good trade. His sales in diamonds are the features of the Fall trade.

Jos. Gosling, of Jos. Noterman & Co., writes from Colorado Springs that he is gaining flesh daily and will return home in a few weeks a well man.

If you have not received O. E. Bell & Co.'s new circular called the "Holiday Ripper," send for it. It will prove advantageous in buying future bills.

Oskamp, Nolting & Co. will mail their holiday circular this week. Over 10,000 will be sent out. The circular is profusely illustrated with every novelty in the market.

Eugene Frohmyer, of D. Schroder & Co., who was ill on the road returned home Saturday morning the worse for wear. He brought in some good lists which redeemed his trip.

E. & J. Swigart are about the busiest people in town. Jewelers realize they must have new trays and boxes to display their holiday goods. The material business is also very good.

Homan & Co. are surprising not only the trade but their competitors with their new goods. They are turning out such quantities that everybody about the plant is kept on the jump. Business has increased to such an extent that another typewriter has been added to the office force.

### Buffalo.

E. A. Smith spent several days in Newark, N. Y., on pleasure and business.

Mr. and Mrs. A. H. Plimpton, Danville, N. Y., spent several days in town last week on pleasure and business.

J. B. Gumbinger, West Bay St., Jacksonville, Fla., left for New York Nov. 5. He will remain there a month to take a course of lectures on optics.

W. W. Parker, New York State representative of King & Eisele, has been home several days with an attack of influenza, but expects to be out again in a few days.

The retailers claim business is not picking up as fast as it ought to, but all look forward to doing all the business in December instead of before, as in former years.

There were few out-of-town jewelers here last week, everybody being busy with election. The following were among those that came in: F. D. Kelsey, East Aurora, N. Y.; Leon Kramer, Gowanda, N. Y.; E. F. Norton, Salamanca, N. Y.; Geo. Crandall, Holland, N. Y.

The Edholm & Akin Jewelry Co., Deadwood, S. Dak., have incorporated with a capital stock of \$4,000, in single shares of \$100, for the conducting and carrying on the jewelry business. The promoters are Arthur M. Akin and Nelson J. Edholm, of Deadwood, and Henry C. Akin, Omaha, Neb.

Some nights ago the store of M. I. Cohen, jeweler, Jacksonville, Fla., was entered by a robber, who was evidently only after money, for so far as known nothing was disturbed except the cash register, and that had nothing in it. An entrance was gained by breaking the transom over the rear door.

Damon Greenleaf and J. H. Crosby, of the firm of Greenleaf & Crosby, Jacksonville, Fla., returned to that city on Nov. 4, after an absence of several months. Mr. Greenleaf spent the greater part of the Summer on a ranch in New Mexico. Mr. Crosby has been north and in Europe, buying an extensive Winter stock of jewelry and fine bric-à-brac.

## THE • THING • FOR • A • XMAS • SELLER.



Finest Finish. Best Quadruple Plate.  
Any Style in Sterling Silver to Order.

### INDIVIDUAL BUTTER AND SOUVENIR PLATES.

Any Name or Initial Engraved to order.  
Any Style. Any Quantity. Order Sample.  
Send for Illustrated Circular.

EXCLUSIVE CONTROL TO LIVE JEWELERS.

½ doz., Plain or Satin, Square or Round, in Plush and Satin Case, complete ..... \$3.00  
Or with Leatherette Satin Lined Case ..... 2.75  
½ doz., Fancy or Initial Engraved Centers, in Plush and Satin Case ..... 3.63  
Leatherette Case ..... 3.38  
Without Plush Case, 75c. less; Leatherette, 50c. less.  
6 per cent. off for Cash with Order.

Also Made in All Styles with Gold Border.  
FOR SURE WINNER ORDER QUICK.

O. E. BELL & CO., Mfgs. Cincinnati, O.

**Trade Gossip.**

The new Princeton watch movements are forging their way into the hands of the trade and are very much admired by those who are able to judge. One thing in their favor is that they are not to be found outside the trade and pay the dealer a living profit. Dealers looking for such watches will do well to investigate the Princeton.

H. M. Rich & Co., jewelry auctioneers, 21 School St., Boston, Mass., made successful sales last month for W. V. Blair, Meriden, Conn.; C. P. Forbes, Greenfield, Mass.; C. G. Small, Easthampton, Mass.; and E. E. Cleveland, Athol, Mass. They have six auctioneers selling for retail jewelers and have only four open dates left for sales up to Christmas.

A very appropriate watch for the holidays and one which appeals to public sentiment and taste is the new initial "Charmilles" watch. These "initials" are made in 10 karat gold on black oxidized steel case and are interchangeable, by which means dealers can easily change the initials to supply the desired letter. This advantage, coupled with the attractiveness of the watch and its very low price, is bound to be appreciated and make it a ready seller.

A unique novelty in the way of hairpins is announced by Paul Jeanne, 18th St. and Fourth Ave., New York, and application has been duly made for a patent thereon. The new pin can be worn alone, making a very handsome ornament, or any brooch may be combined with it in such a manner that, while securely attached, the brooch is nevertheless free to revolve and always remains in full view, no matter what may be the position of the wearer's head. These pins are made by Paul Jeanne in gold, silver and enamel.

Jewelers contemplating taking a course in optics should obtain the announcement issued recently by the St. Louis Ophthalmic College and Hospital, 1655 S. Jefferson Ave.,

St. Louis, Mo. This is a school of theoretical and applied optics, for physicians and opticians, which can well be recommended. Its course of lectures which begins the first Monday of each month and continues for four weeks, embraces lectures on anatomy, physiology and pathology of the eye, physical and physiological optics, the use of the ophthalmoscope, retinoscope, perimeter, ophthalmometer, the adjusting of lenses and frames, errors of refraction, muscular innervations, etc.

As announced elsewhere the A. C. Smith Watch Co. have decided to discontinue the "complete watch" branch of their business and to hereafter confine their trade exclusively to watch movements handled through the jobbing trade. This change is due to the impracticability to handle two branches of business with two sets of customers and a desire to concentrate the manufacture on a special line of watch movements which the company are preparing to bring out. It is well known that the company's stock of complete watches is one of the finest in the country and the special offer they make is a great opportunity to buy fine watches at prices considerably less than manufacturing cost and one which should attract the attention of every jeweler having a trade in fine watches. This entire stock is advertised to be closed out regardless of cost by Jan. 1st. This special call, of course, does not include that marvel of simplicity the "Charmilles" watch in which the company's business is fairly booming.

The manufacturers of the "Princess" rings have in their special field a reputation second to none. In their attractive full page display on the second page of this issue dealers will find interesting reading. The lapel buttons in solid gold and in sterling silver are specially salable goods and the prices at which they are offered explains this very readily. These buttons are made for all known societies and are carried in stock. In emblems there is illustrated a thirty-second, a Knights' Templar, and a

Shrine. These goods the manufacturers confidently assert to be the very finest of their kind in the market. The silver monogram pins shown can be furnished in any desired combination of letters. Now a word about the patented Princess diamond initial rings. They are too widely and favorably known to make encomiums necessary and have been on the market for over twelve years *without a single complaint ever having been received* by the manufacturers. The simplicity of the interchangeable device in particular is a feature much appreciated. "It is the only initial ring worth having" wrote a well pleased customer recently when ordering more Princess rings.

The annual catalogue of the "Busiest House in America," Lapp & Flershem, Chicago, Ill., has again made its appearance. In this the 19th number, for 1895, the volume appears in an enlarged and improved form, consisting of 600 pages, 9 x 12½ inches instead of 6½ x 10 inches as heretofore. The thousands of cuts which adorn its pages illustrate and give prices of this firm's principal lines of silver plated hollow ware, table cutlery and novelties; aluminum ware; sterling silver ware; optical goods, cases; gold and silver headed canes; pens and pencils; onyx, marble, wood and nickel clocks; bronzes; watches, watch cases and movements; diamond, gold, silver and rolled plate jewelry and novelties; medals and emblem goods, etc. The catalogue, which is one of the largest and most complete of its kind issued in the jewelry trade, is neatly bound in cloth, and has the recipient's name in gold upon the cover. Like its predecessor, the book contains the name of Lapp & Flershem nowhere between its covers, and all the prices quoted are subject to discounts, for which a key is sent under a separate cover. The jeweler is thereby enabled to take orders directly from the catalogue, or permit it to be inspected freely by his customers without danger of their detecting the jobber from whom or the prices at which he buys his goods.



**ONE OF THE 400, AND VERY SWELL INDEED.**

**THE PERFECT FIT OF OUR No. 918 GOLD EYE GLASS, SWELL END EYE WIRE.**

Our Ambition to Make a **FAULTLESS GOLD SPEC.** and Eye Glass has been realized, and is appreciated. Strength and Beauty Joined Together **WITHOUT SOLDER.** You "see that hump" no longer. It's gone, and in its place, at ends and bridge, you find that **GRACEFUL SWELL**, as shown in cut. *This is the Modern and Perfect Frame the public are asking for, made in all weights, sizes, shapes and qualities.*

**WE MAKE ALL KINDS OF OPTICAL SPECIALTIES, AND TEACH HOW TO GET BEST RETURNS IN HANDLING THEM.**

**THE AUDEMAIR OPERA GLASSES,  
SPENCER OPTICAL MFG. CO.,  
15 MAIDEN LANE, NEW YORK.**

**CALL OR WRITE. IT WILL DO YOU GOOD!**

The Best Made for the Least Money. Also Cheaper Grades. The Greatest Variety of Styles. Great Reductions to Correspond with New Tariff and Other Causes. **SEND FOR NEW SUPPLEMENT.**



## MATTERS IN JEWELRY STOREKEEPING.

That this department shall prove mutually beneficial to our readers, it is desirable that the members of the trade generally communicate with THE CIRCULAR regarding any advantageous device or plan that they are utilizing in the conduction of their business.

### Suggestion for Window Decoration.

IDEA LXXVII.

THE illustration herewith depicts a display recently seen in the window of E. L. McDowell, Arkansas City, Kan., during the week of the Soldier's Reunion in that city. The engraving requires care-

carried out with good effect, as was attested by the attention the display attracted. A clever ad. uniquely arranged appeared simultaneously in the daily press; it read as follows: "Ahead of Palmer Cox. Brownies at War, in the window of the Crescent Jewelry Store."



WAR OF THE BROWNIES.

ful inspection before the full significance of the window decoration can be appreciated. The idea represents Palmer Cox's Brownies at War. The floor of the window is arranged to resemble a field of battle, with fortifications, outposts, tents, and all the "pomp and circumstance" of war. Numerous miniature figures are distributed in line of battle and look very terrible indeed. The conception is very clever and has been

### An Attack that Proved an Advertisement.

TWO jewelry firms of Westerly, R. I., A. E. Hahn and W. B. Smith & Co., have been indulging in a little competition bout in which the former seems to have come out somewhat ahead. Mr. Hahn advertised in the local papers a special sale of silverware for one week only, and as a leader quoted Rogers knives and forks at

\$3.75 per dozen. The following day this notice appeared in the papers:

**B**EWARE! Rogers & Bro. knives, forks and spoons are now on the market in second quality. They are sold at \$2.85 per doz. Tea spoons \$1.50 per doz. The reliable goods we sell at \$3.75 per doz. all the year round. Buy from reliable dealers always. Don't pay \$3.75 for the \$2.85 goods.—W. B. SMITH & Co., Westerly.

Hahn then advertised as follows:

**\$100** REWARD. In last evening's issue of your paper, a competitor of mine has a notice to the public, telling them to "beware" of the quality of Rogers' goods, which are now on the market. As I have now on sale Rogers' goods, and have advertised the same, I take it for granted that said notice reflects on my advertisement. I, therefore will give anybody, including my jealous competitor, the sum of \$100, if they, or he, can prove that the knives and forks I now have on sale, are not first-class, and the genuine Rogers' goods. HAHN, the Jeweler, Barber Memorial Building, Westerly, R. I.

He then procured from the bank a \$100 dollar bill, and with that placed his competitor's notice as well as his own notice of reward in his show window, the bill being attached to an upright nickel stand. The exhibit proved the means of attracting a great many people to the window, there being a constant crowd around it waiting to read the notices. This effective advertising aided the sale considerably. One of the local papers had the following notice:

"For those who are not in the habit of seeing such things, a glance into the window of Hahn's jewelry store, on High St., yesterday revealed a \$100 bill."

It may be said, in comment of the above controversy, that there is no second quality of the genuine ★Rogers & Bro. A 1 brand of flatware, and that we consider it wrong on the part of Smith & Co. that they should endeavor to lead the people of the town to believe that there is

**Care in Putting Up a Watch.**—The brass guard pin in the end of the fork should be perfectly upright or the watch will not run at the same rate in different positions, and should be near enough to the roller to just pass in the crescent, and after passing should have a sideshake of about the thickness of writing paper. The roller jewel should enter the fork well, but not touch the horn of the fork in entering. Put in the balance wheel and see that it has a perceptible end-shake, and that is all. If the balance jewels are too large, change them or put in new staff. If any of the pivots are cut, polish them in the lathe and put in smaller jewel holes, or insert new pivots. See that the hairspring is perfectly flat and true in the round, and, above everything, put the watch in beat.

## A MOVING DISPLAY

FOR THE HOLIDAYS.

The Best Attraction in the World—a Moving Advertisement in a Window.

OUR ELECTRIC REVOLVING SHOW STANDS

Are of various styles, made especially for jewelers. They are equivalent to a four fold increase of Show Window space. It runs steadily ten hours per day, at an expense of two cents per day. Made to be operated by either battery or electric light current.

Send for Circular of Illustrations.

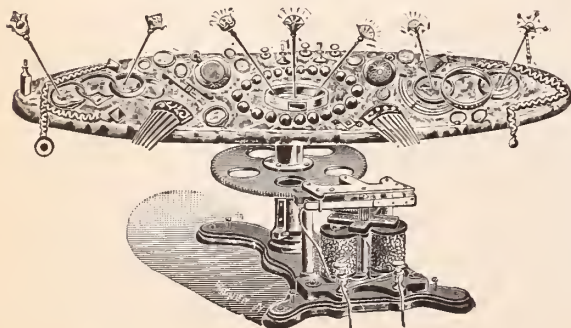

FREDERICK PEARCE,

77 & 79 John St., N. Y.



### Deadening the Loud Tick in American Clocks.

[From the *Deutsche Uhrmacher Zeitung*.]

SELDOM has an article of our industry met with so rapid and general a reception as the well known, American clock. It is cheap almost to a fault, of a pleasing exterior, and well calculated to gain public favor. To this may be added that in consequence of the practical construction, and in spite of the highly primitive tech-

In order to remedy this evil, Mr. C. Hahlweg, of Stettin, has contrived the following device: The several pins as well those serving as pallets, as the impulse pins, are elastic, being fairly long, and made weaker by filing near their point of fastening, whereby naturally care has to be taken that the safety of the depthing of the escape wheel into the pallets and from the impulse pin into the fork is not interfered with. Accompanying illustrations represent the escapement parts with these elastic pins, for which the inventor has received a German patent.

FIG. 1.

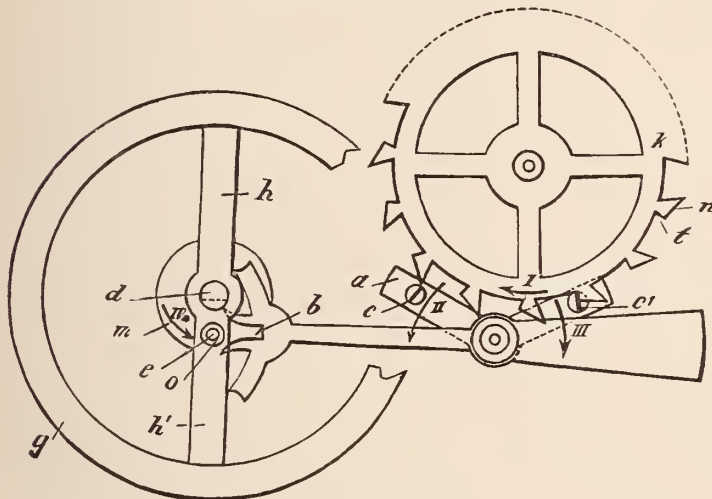

FIG. 2.

FIG. 3.

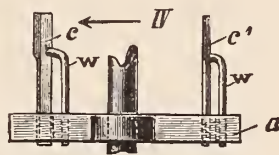
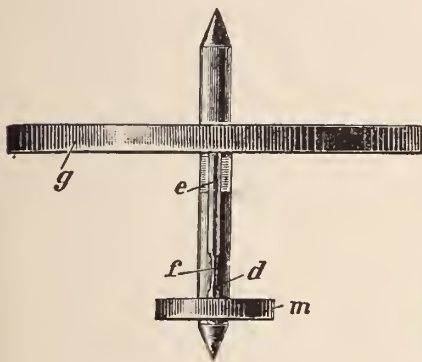
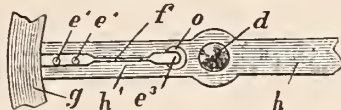

FIG. 4.



nical get-up, these clocks comply with all the reasonable demands made of them as alarm or room timepieces, and this is doubtless the principal reason why they may be found in nearly every room, house or shop of the civilized world.

But they are open to one great objection, and that is their hard, loud tick. This is caused by 1st: The excessive spring force of nearly all the springs in American watches or clocks; 2d: The very thin wheels, especially the escape wheels, the inertia of which, on account of their lightness, is extremely small, whereby the drop of the scape teeth upon the pallets, occasioned by the strong spring, is still increased; 3d: The thin cases will, on the one hand, deaden the sound but little, while on the other hand the movement is firmly and metallically, by direct screwing, fastened to the case, which, therefore, acts, as it were, as a bell to every tick of the clock.

of the escape wheel, which causes a proportionally powerful blow. By this is effected that the drop of the escape wheel, which otherwise produces a hard, ringing stroke on one of the rigid pins, becomes soft and soundless by the drop on an elastic spring blade.

received a German patent.

As will be seen from Figs. 1 and 3, into the pallet *a* are fastened in place of the ordinary round, rigid pins, two flat spring blades *cc'* of such a thickness that they partially yield when the escape wheel *k*, moving in the direction of the arrow *I*, drops with one of its teeth on one of the spring blades *cc'*. These blades, however, are not so weak that the quietly acting (that is, exerted during the rest) power of the escape wheel is able to bend them—they only yield for a moment during the drop

The spring blades, which are elastic only in the motion direction of the escape wheel, therefore in the direction of the arrow *4b*, I do not yield in the motion direction of the pallet arrow (II and III), therefore in the lifting of the pallet, because they stand at a high edge to the lifting planes *u* of the escape wheel and remain rigid in this direction. The lifting of the pallet consequently takes place just as safe and as powerful as if the pins were rigid.

Although the spring blades *cc'* are sufficiently stiff to stand free without brace,



SPECIALTY: SALES OF  
**JEWELRY BRIC-À-BRAC**  
AND  
ARTICLES OF VERTU

WHITE'S EYE SHADE. **W. B. WHITE & SON**  
MANUFACTURERS OF  
Spectacle and Eye Glass  
CASES  
90 SOUTH STREET, BOSTON.  
Special Cases made to order for Optical Trade. Cases for Trial Lenses. Opera Glasses recovered, etc. Chatelaine Spectacle Cases Metal Bound Leather Cases for combs, scissors, etc. Over forty kind of cases manufactured.

**WOOD & HUGHES,**  
STERLING SILVERWARE MANUFACTURERS  
New York Agents for the Derby Silver Co.'s  
FINE QUADRUPLE PLATED WARE,  
No. 16 JOHN STREET, NEW YORK.  
206 Kearney St., San Francisco, Cal.  
HASKELL & MUEGGE, Agents.

**We Know** THAT WE CAN GIVE YOU BETTER RETURNS ON YOUR OLD GOLD AND SILVER OR WASTE THAN ANY ONE ELSE. TO PROVE THIS STATEMENT GIVE US ONE TRIAL.

**GEO. M. BAKER,**  
GOLD AND SILVER REFINER AND SWEEP SMELTER. PROVIDENCE, R. I.

nevertheless for the sake of greater safety two pins  $w$  may be located immediately before these springs, as shown in Fig. 3. these pins are bent over at right angles at about three-quarters of the length of the spring blades, and made to lie loosely with their ends on the latter. This arrangement acts as a support and the blades stand steadier without disturbing their functions. The drop of the wheel teeth takes place at the outer end of the blades  $cc^1$ , in the direction of the arrow IV.

Another noise is caused by the circumstance that in the unlocking of the pallet from the locking, the lifting pin  $e$ , Figs. 1 and 2, strikes against the fork  $b$ . It is well known that with unelastic pins the balance must recoil the escape wheel a little in the unlocking, and since hereby not only the living force of the escape wheel must be overcome, but also its inertia, which two factors exert a fairly large resistance to the rapidity of the unlocking, it is necessary that the balance strikes fairly hard with the lifting pin  $e$  against the fork, whereby a hard tick and at the same time an essential loss of power for the vibration of the balance is generated. Both these errors are avoided by using the elastic pins, because at the moment when the balance strikes with the pin  $e$  against the fork to unlock the pallet, the escape wheel needs not be carried back, but one of the spring blades which is just then in locking, yields with an elastic motion in the concussion before the rising locking plane  $t$ , Fig. 1, of the escape wheel,\* whereby the unlocking of the pallet takes place much easier than if the escape wheel would have to be led back. It is evident, there-

\* The technical editor gives the wording of the patent writings, without, however, subscribing to the deduction expressed in it because he doubts the correctness of the statement, after it has been expressly stated above that the spring blades  $cc^1$ ,—as is evident—are so strong as to bend only at the drop of the escape wheel. But as this wheel stands in locking at the moment of the unlocking of the pallet, the spring blade (and he thinks the attentive reader will come to the same conclusion) against which the tooth lies at the time, will undoubtedly remain rigid, and the escape wheel, as is also the case with any other lever escapement withdraw, will experience a recoil.

fore, that by the elastic pins the hard stroke of the wheel on the pins, as well as that of the balance pin  $e$  on the fork is moderated quite extensively, and the ticking of the clock is exceedingly deadened thereby, while at the same time its escapement acts with greater force by reason of this ameliorated unlocking.

Beside these pins, the impulse pin  $e$  can also be made elastic, which may be done in different ways. Figs. 1 and 2 represent such a disposition of the pin  $e$ ;  $g$  is the balance,  $h$   $h$ , its arms,  $d$  the balance staff. The fork depths nearly underneath the balance  $g$ , Fig. 2, into the impulse pin  $e$ . At the lower end of the staff  $m$  is mounted a disc  $m$ , into which the extraordinarily prolonged pin  $e$  is fastened. This is near its fastening point, to wit, at  $f$ , filed flat on two sides in a radial direction toward the balance center, so that it will be elastic at this place, in a concentric direction only, however. To protect this pin against bending, its upper end is pushed through a hole  $o$ , Fig. 1, in the balance arm  $h$  which is large enough to permit the impulse pin  $e$ , to exert its full elasticity.

Another arrangement of the kind is shown in Fig. 4. Here also, the balance arm  $h^1$  is furnished with a hole  $o$ , through which passes the impulse pin  $e^3$ ; this, however, is at its upper end bent at right angles and filed out in form of a spring  $f$ , which is with two rivets  $e^1$  fastened to the arm  $h^1$ . With form of the spring, it is self-evident that the impulse pin can give way only in a direction concentric to the axis, but not radially. The safety of the depthing of the impulse pin into the fork is therefore not at all interfered with by the elasticity of the pin  $e^3$ , and the stroke of the pin on the inner sides of the fork is largely moderated.

In case, says the paper, that the disagreeably loud tick of these clocks can be modified, it will doubtless be hailed as an immense improvement of these universally popular timekeepers.

Isaac Fuller's jewelry store, Lone Rock Wis., was recently robbed of \$200 worth of goods.

## Workshop Notes.

**Shape of Pivots.**—Pivots should be cylindrical, well tempered, with a shoulder or bearing at right angles, but rounded at the end; the same may be said of the pivot holes. The material entering into their composition must not be easily oxidized by the action of the oil, and it is of advantage to have them somewhat olive shaped inside, with ends lemon shaped and extending beyond the oil links. They should bring the oil to the pivots, and for this the sharp angled pivot is the best.

**To Test the Stopwork.**—Take up the winding square of an arbor with the barrel, etc., in position, in a pair of sliding tongs or a Birch's key; hold the tongs between the last three fingers and the palm of the left hand, the first finger and thumb being applied to the circumference of the barrel so as to rotate it, first in one direction and then in the other. During this movement take a pegwood point in the right hand, and try to turn the star wheel *against* the direction in which it would be impelled by the finger.

**Order in Watch Cleaning.**—To facilitate the work by securing order in taking down the watch and cleaning it, preventing the screws from being mixed, it is a good practice to prepare beforehand one or more boards, in which grooves and holes are made in positions to correspond with those of the several pieces on the plate of the watch, and the young beginner should at once learn that in no department of watch repairing does order pay as well as in the taking down. At first he will find an advantage in noting on a slip of paper bearing the number of the watch, the successive operations that have to be done. He will then merely have to strike them out one by one as the work progresses. As he becomes more practical he can dispense with this auxiliary.

**To Clean With a Brush.**—This method is less used now than formerly, as it can be adopted with safety with the old fashioned gilding, but it is too severe for the thin galvanic coats that are applied at the present day. It may, however, be resorted to for getting up the surface of polished brass wheels, for example. Put some French chalk or powdered hartshorn (which can be bought at a chemist's or drug store) in pure alcohol. Shake the mixture and with a fine paint brush, coat the object with a small quantity of it, subsequently brushing the surface with a brush that is in very good condition. Polished wheels may be made to present a very brilliant appearance by this means, but their teeth and the leaves of pinions must be afterward carefully cleaned. The French chalk and hartshorn are all the more effective according as they have remained a longer time in the alcohol, doubtless owing to the fact that the hard grains met with in these agents are then more completely dissolved.

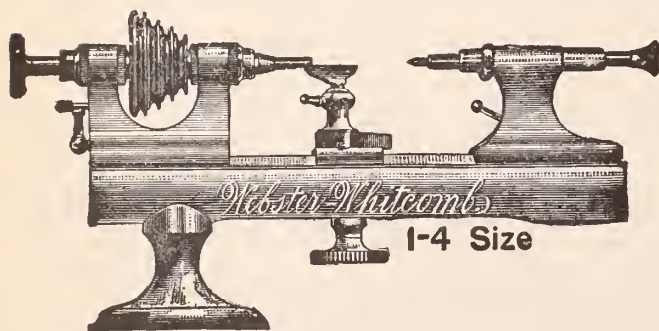

STRONGEST GUARANTEES.

Quality  
Maintained.  
Prices to  
Suit the Times.

Ask for our New  
Prices and  
Terms for 1894.

American Watch Tool Company,  
Chymistry Dist., Waltham, Mass.. Stoney Batter Works.

# RUDOLSTADT

HIGHEST  
AWARD  
WORLD'S  
COLUMBIAN  
EXPOSITION.



## ART POTTERY.

CONTAINS all the elements required as to designs, decorations and workmanship, in a high grade of Art Goods adapted to the Jewelry Trade, and yields a larger margin of profit than any other class of Pottery.



### L. Straus & Sons,

SOLE AGENTS,  
42-44-46-48 Warren Street,  
116 Chambers Street,  
NEW YORK.



**..THE LATEST..**  
**Sterling Silver Novelty,**  
**CIGAR CUTTER**  
**AND KEY RING COMBINED.**  
(Patent applied for.)  
WITH OR WITHOUT CHAIN.

MADE ONLY BY  
**ENOS RICHARDSON & CO.,**  
23 Maiden Lane, New York.

## CAMPBELL-METCALF SILVER CO.

FACTORY:  
STEWART ST.,  
PROV., R. I.

N. Y. OFFICE:  
2 MAIDEN LANE.

SAN FRANCISCO:  
112 KEARNY ST.

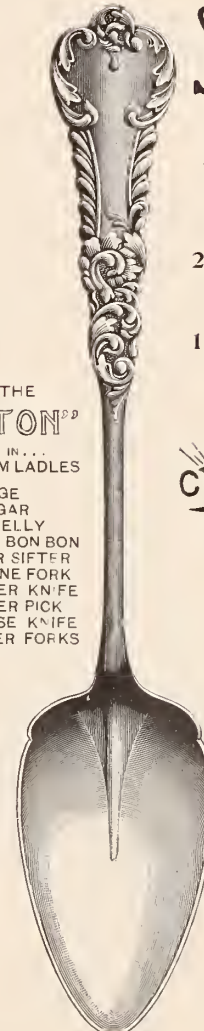

THE  
"ETON"  
... IN ...  
CREAM LADLES  
ORANGE  
SUGAR  
JELLY  
BON BON  
SUGAR SIFTER  
SARDINE FORK  
BUTTER KNIFE  
BUTTER PICK  
CHEESE KNIFE  
OYSTER FORKS  
ETC.



OUR  
"ETON"  
AND  
"STUART"  
PATTERNS  
ARE IMMENSELY  
POPULAR  
AND SELL AT SIGHT  
WRITE DIRECT  
TO FACTORY FOR  
SAMPLES  
AND PRICES.

## FANCY

.. IN ..

SCARF PINS

AND LINKS.



## FIGURES

STERLING SILVER,

Enameled in Colors.

QUICK SELLERS.

Dudes, Chinamen, Policemen, Sailors, Orators, Cadets, and all other Shapes Made.  
SEND FOR SAMPLES.

If your Stock does not include our **GOLCONDA GEM** Line you are losing sales. This Stone is Mounted in Studs, Scarf Pins, etc., in Solid Gold and Plate.

If your jobber doesn't keep these goods write us and we will send you the address of a jobber in your vicinity who does. Every card bears the words "THE GOI CONDA GEM, Reg'd." all others said to be "equally as good" are spurious. Bear this fact in mind

**R. L. GRIFFITH & SON, = PROVIDENCE, R. I.**

## HILDRETH M'F'G CO.,

53 MAIDEN LANE, NEW YORK.

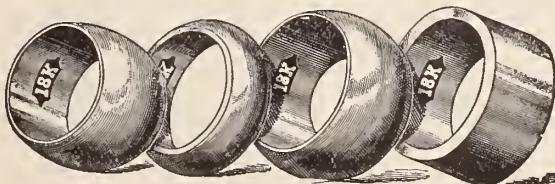

Standard Quality. Standard Prices. Finest Finish.  
**Plain Solid Gold Rings.**



# FERDINAND BING & Co.,

106 GRAND ST., N. Y.

NEW DESIGNS IN

China Clocks and Gilt Bronze Sets, Fine Painted  
 Dresden Goods in Vases, Cups and Saucers, and Plates;  
 Cararra Marble Statuary, French Cabinets and other  
 Fancy Furniture.

## GEO. W. SMITH & CO.,

MAKERS OF

# HIGH · ART · FURNITURE,

ESPECIALLY ADAPTED FOR

## JEWELRY AND ART TRADE.

Cabinets, Pedestals, Jardinere Stands, Onyx Top Tables, 5 O'clock Tea Tables, Cario and Souvenir Spoon Cases and Cabinets.

### HALL CLOCK CASES.

FACTORIES,

3907-19 Powelton Ave., Phila.

NEW YORK SALESROOM.

818 Broadway, H. P. Vollmer, M'g'r.

## RICH CUT GLASS.

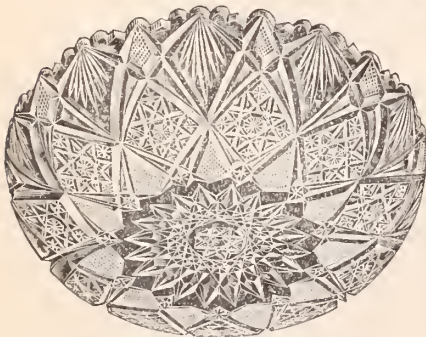

7 INCH NAPPY. SAVOY CUTTING. BOTTOM VIEW.  
 The illustration does not fully show the handsomely scalloped edge.

The Pattern herewith shown is that long desired medium between the Strawberry Diamond Fan and the higher priced cuttings. The HURON and some other moderate priced patterns have been much liked by jewelers, but the SAVOY has taken them by storm. We specially recommend it to that trade.

## T. B. CLARK & CO., Inc.,

860 BROADWAY, NEW YORK,

Factories, HONESDALE, PA.

North East Cor. 17th St. and Broadway.



CHASED, No. 1617, \$4.50 PER DOZ.  
 PLAIN, No. 1614, \$3.75 PER DOZ.

### ◆◆ OUR KEY RINGS ◆◆

are the best in the market for the price. They are quick sellers and make good card prizes. Our Czarinas, Collar Buckles and Belts are just as popular as ever. Shell Hair Pins and Side Combs with sterling trimmings in all styles. Watch Pockets and all the latest in sterling silver.

### CODDING BROS & HEILBORN,

NORTH ATTLEBORO, MASS.

New York office, C. A. Vanderbilt, 178 Broadway,  
 Chicago office, F. A. Buck, 103 State St.

### “SECURITY PIN GUARD.”

Can be Used on Scarf or Ladies' Pin.

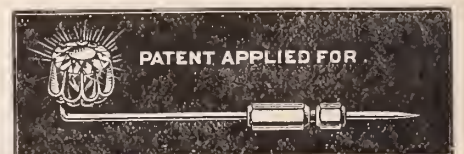

85c. Dozen Gold, \$6.00 } Doz.  
 Net Cash. Silver, 3.00 } Net Cash  
 DISCOUNT TO JOBBERS.  
 Security Mfg. Co., 7 Astor House, B'way, N.Y.



### New Goods in Rudolstadt.

THREE representative pieces of the Fall line of Rudolstadt pottery are to be seen in the illustrations herewith. The beauties of this ware which has often been described in these columns, are too well known to the jewelry trade to need further comment. It will be noticed in the pieces here shown that the shapes are new and though somewhat out of the usual style, are very graceful. The decoration which these pieces display is known as the "Cloisonné," and consists of artistically colored flowers outlined in gold on a cream ground. These pieces must be seen for one to obtain full appreciation of the delicacy of their finish and decoration.

"Cloisonné" decoration many smaller articles, such as teapots, sugars, creams, bonbon baskets and boxes, and candlesticks, which will be of interest to the jewelry trade.

### Good Prices for Keramics.

KERAMICS have increased in favor. and this season prices at various sales

A set of old Chelsea, 168 pieces, was very cheap at 200/, but the lot being unbroken, probably put it out of the means of the ordinary china maniac, who mostly picks up a piece at a time. Fourteen old Worcester plates have realized 83 guineas, an old Dresden service 110 guineas, a big clock in blue Sèvres porcelain 165 guineas, and two other pieces of Sèvres blue, 125 guineas.

The best prices of all have been made for Henri Deux ware, in which there is a remarkable advance, the craze being at least as violent in France as in England. Exact figures are not available, but over a



SPECIMENS OF RUDOLSTADT WARE—L. STRAUS & SONS.

As the trade well knows, this ware is controlled by L. Straus & Sons, 42 48 Warren St., New York, who are now showing one of the largest varieties of it that they have ever displayed. In addition to the vases, pitchers, urns and other pieces of pottery, there will be found in the

in England show a rise. A Rose del Barri jardiniere has fetched 320/, a piece of old majolica 81/, a lusted Gobbio dish illustrating the martyrdom of St. Sebastian, 126/, a large fan shaped china dish beautifully painted on a pale blue ground, 405/, and two vases of old Chinese porcelain, 252/.

thousand guineas for a single piece has been paid quite recently. Henri Deux "flourished" 1547-59, and represents the early "French" Renaissance.

John Yost & Son, of Fresno, Cal., have retired from business.

**The Connoisseur.**

(Continued from page 43.)

**The Rambler's Notes.**

WHAT THE RAMBLER SAW AND HEARD AMONG THE DEALERS IN ART POTTERY, CUT GLASS, BRONZES, ETC.

**J**EWELERS cannot fail to be interested in the line of Dresden novelties which Chas. Ahrenfeldt & Son, 52 Murray St., New York, are displaying. Among the pieces carried especially for the jewelry trade are the Dresden china backs for hat, clothes and hair brushes, and for combs. These are as light and delicate as is consistent with durability, and show gilt, Watteau and large and small flower decorations. Bonbonnières form another jewelry line. The shapes, mainly hearts, eggs and cradles, show a wide range in size and have decorations similar to those on the brush backs. Other similar novelties are the trays, lamps, photograph and miniature frames, calendar holders and tea caddies.

\* **T**HE handsome fruit bowl here illustrated is one of the special pieces in the new line introduced



CUT GLASS ON BRASS STAND.

by the T. B. Clark Co., 860 Broadway, New York, of brass and cut glass. This

**Jules Jürgensen**  
OF COPENHAGEN.

The reputation these watches have maintained for Fifty Years has never been equalled, being made on strictly scientific principles and no expense spared to give the Best results in mechanism and timekeeping qualities.

SOLE AGENTS,  
**John C. Hyde's Sons,**  
NO. 22 MAIDEN LANE.

line was spoken of in this column two weeks ago. As before stated these bowls, which come in eight and nine inch sizes, show unique and most artistic combinations of cut glass and solid cast brass work finished in matt and burnished gold effects.

gold and bright colors on a pale ground, are to be seen in the Taizan and Satsuma wares. Very rich looking lamps with perforated designs are those in Benares brass or Persian bronze. They show library, banquet and princess sizes in many queer



GROUP OF ORIENTAL BRONZE AND PORCELAIN LAMPS.

**R**ICH ORIENTAL LAMPS. IN probably no other article does the richness of the Japanese and Chinese art pottery and bronze work show to better advantage than lamps. This statement may easily be verified by a visit to the warerooms of A. A. Vantine & Co., 877 Broadway, New York, who show what is probably the largest assortment of these lamps in the United States. The illustration depicts a representative group from their warerooms. In Japanese bronze there will be found lamps of many styles in banquet, library and piano sizes. The shapes are principally vases, pedestals and koros. The greatest variety is to be seen in blue and white; of these one of the principal wares is the Itrado which shows library, princess and banquet pedestal lamps with raised dragon decorations on an underglazed blue and white ground. Other similar pieces in library and banquet sizes are in Hawthorne and Chinese blue and white. Brilliant decorations, mainly

designs. In one, a pedestal lamp, three cobras form the support of the fount. Among other desirable styles are the Cloisonné, Awayi ware and Tokanati. This last is a red terra cotta pottery with raised dragon decorations. In connection with the lamps a beautiful collection of lamp shades is shown in Chinese silk, lace, rogauze and chiffon. There is also a variety of lamp veils for small lamps. These are of lace richly embroidered.

\* **A** SEASONABLE line displayed by **FINE GLASS TUBES AND HOLDERS.** Hinrichs & Co., 31 Park Place, New York, includes glass chrysanthemum vases of many varieties. Green crystal tubes, green vases decorated with gold scrolls, Bohemian glass tubes and holders in varigated colors and many shapes, plain crystal with hand painted figures, and rich cut glass vases are among the most popular pieces shown.

THE RAMBLER.

**Fountain Pen 14 Kt. Solid Gold Nib**



**\$7.50** Net Cash  
DOZ. with Order.

Elegant Plush Lined Box FREE. Every Pen Warranted. Send for Catalogue.

**DIAMOND POINT PEN COMPANY, 7 Astor House (Broadway), New York.**

**Novelties in Bronze and Solid Silver**  
**Especially Suitable for Jewelers.**

Metal Pen Trays, gold lined silver and oxide figures; Sugar Tongs, wild rose, cowslip, violet, daisy patterns; Small Spoons, gold lined; Solid Silver Spoons, cloisonné enamel bowls and handles; Solid Silver Napkin Rings, gold inlaid; Silver Repoussé Teapots and Lamps; Gold Lacquer Tea Caddies; Fancy Shape Jewel Boxes; Fancy Shape Match Boxes; Fancy Shape Stamp Boxes; Metal Ink Wells; Fine Lacquer Work Boxes, Writing Tablets.

If you desire samples, we will be pleased to send you one piece of a kind.



**A. A. Vantine & Co.**

LARGEST IMPORTERS: JAPAN, CHINA, INDIA, TURKEY AND PERSIA.

Wholesale: 18, 20 and 22 East 18th St. Retail: 877 and 879 Broadway, N. Y.

**SAFES FOR JEWELERS.**

**MOSLER, BAHMANN & CO.,** 518 BROADWAY  
 NEW YORK.  
 Patent Fire and Burglar Proof Safes.

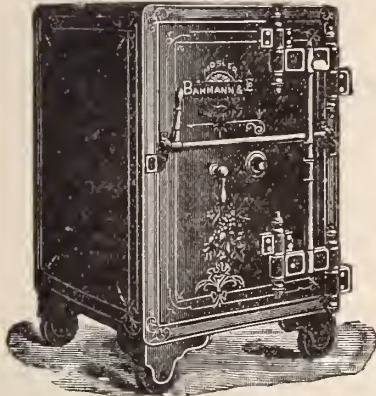

Large Assortment Always on Hand.  
 Send for our Representative.  
 Special Safes to Order.  
 Jewelers' Safes a Specialty.

**2 MEDALS AWARDED**



Providence Shell Works, Providence, R. I.  
 Correspondence Invited.

**FERD. FUCHS & BROS.**  
**SILVERSMITHS,**

MAKERS OF STERLING SILVERWARE,  
 808-810 Greenwich St., New York.

**A. J. HEDGES & CO.,**

MANUFACTURERS OF

Gold, Variegated and Enameled Jewelry.

**BLACK AND WHITE ENAMELED GOODS**  
 — A SPECIALTY. —

SIDE COMBS AND COLLARETTES, LACE PINS, SCARF PINS,  
 BROOCHES AND PENDANTS, CHATELAINES AND  
 BRACELETS, LINK BUTTONS AND STUDS, LADIES'  
 AND GENTLEMEN'S GOLD AND SILVER GARTERS.

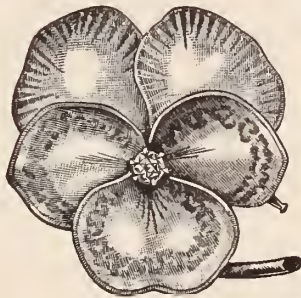

FACTORY;  
 90 Mechanic St., Newark, N. J.

**6 Maiden Lane, New York.**

**L. SAUTER & CO.,**

**Dealers in Diamonds**

... AND ...

**Makers of Fine Jewelry,**

194 BROADWAY, NEW YORK.



Selection Packages sent on request. Mounting of Diamonds and other  
 precious stones in new and original designs a specialty.

LATEST STYLES

.. IN ..

FINE JEWELRY.

GOLD BUCKLES,  
HAIR PINS,  
BACK COMBS,  
SIDE COMBS,  
NECK ORNAMENTS, Etc.

John A. Riley & Sloan Co.,

Broadway and 17th Street,  
NEW YORK.

No jeweler or watch repairer should be without a copy of "WORKSHOP NOTES," a new and very useful book for the workshop. Send for circular containing a complete index of the book, and judge of its merits for yourself.

Value of Royal Crowns.

REGAL crowns are an expensive luxury for the people of those backward countries which still prefer to have kings to presidents. One of the most costly crowns in existence is that of the King of Portugal. The jewels which ornament it are valued at \$8,000,000. The crown which the Czar of Russia wears on special occasions is also one of the most precious in the world. The cross which surmounts the crown is composed of five magnificent diamonds resting on a large uncut but polished ruby. The small crown of the Czarina contains, according to authorities, the finest stones ever strung.

The crown of the Queen of England, which is valued at \$1,800,000, contains a great ruby, a large sapphire, sixteen small sapphires, eight emeralds, four small rubies, 1,360 brilliants, 1,273 rose diamonds, four pearl formed pearls and 269 of other shapes. In his State clothes, including the crown, the Sultan of Johore wears diamonds worth \$12,000,000. His collar, his epaulets, his girdle and his cuffs sparkle with the precious stones. His bracelets are of massive gold, and his fingers are covered with rings which are almost priceless. The handle and the blade of his sword are covered with precious stones.

The most costly insignia of princely dignity, however, are those of the Sultan, or Maharajah, of Baroda, in India. The chief ornament is a necklace of five strings containing 500 diamonds, some of which are as large as hazel nuts. The upper and lower rows consist of emeralds of the same size.

The Other Side of Life.

One by one, like fleeting dreams,  
His fondest hopes took wing.  
She did not keep the tryst, alas!  
She did the diamond ring.

—Puck.

SHE—Are these ten-day clocks?  
HE—No, Ma'am; ten-dollar clocks.—  
*Yonkers Statesman.*

OFFICE-IMP—Please, sir, the fo'man says we're outen copy.

EDITOR—Out of copy? Well, tell him to mix up that tea tasting article with that Dresden China essay—head it "War over Corea," and let her go.—*Puck.*

"Ma," said a six-year-old, "can I wear your gold ring to-day?"

"No, dear."

"Why, you let Pa wear it."

"I know; but he won't lose it and you might. When I die you can have it."

"But you may not die for some time."—  
*Norristown Herald.*

At the boarding-school.

FIRST GIRL—What is the matter with these pickles?

SECOND GIRL—Don't they taste right?

FIRST GIRL—No; they're horrid.

THIRD GIRL—I'm sorry, girls; but I was just out of hairpins and so I took a fork to get them out of the bottle.—*Judge.*

R., L. & M. Friedlander,



We have made great reductions in the prices of Watch Glasses.

SEND FOR PARTICULARS

Are now located on  
ground floor of

30 Maiden Lane, N. Y.

IMPORTERS OF  
DIAMONDS.

WHOLESALE  
JEWELERS.

JOBBERS IN  
American Watches.

SEND FOR OUR NEW CATALOGUE.

H. M. SMITH & CO.,  
MANUFACTURERS,



83 NASSAU STREET, - - NEW YORK CITY.  
New Catalogue Just Issued.





# HINRICHS & CO.,

29 & 31 Park Place, N. Y.

## HOLIDAY GOODS FOR JEWELERS.

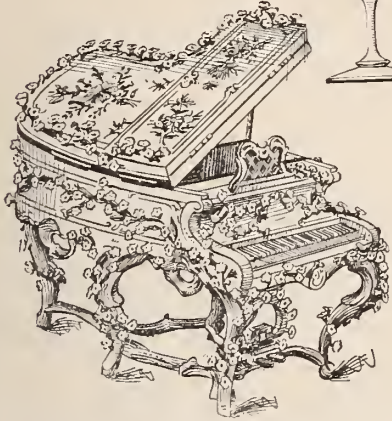

ITALIAN MARBLE BUSTS,  
PARIAN BUSTS and FIGURES,  
BISQUE FIGURES and GROUPS,  
FRENCH CHINA CRACKER JARS,  
CHOCOLATE POTS, TRAYS, BOWLS,  
SOUVENIR A. D. COFFEES, TEAS, Etc.  
ST. GERMAIN AND GERMAN-AMERICAN STUDENT LAMPS.

### BRIC-A-BRAC AND ART POTTERY.

SEND FOR CATALOGUES.



WE MANUFACTURE

## STERLING SILVER TABLE WARE, IN COMPLETE LINES.



TOWLE  
MANUFACTURING  
COMPANY,

OLD ENGLISH TE E-A-TETE TONGS.

CHICAGO, ILL.,  
49-151 STATE STREET.

NEWBURYPORT,



## BURGLARY INSURANCE.

### Fidelity AND Casualty Co.

OF NEW YORK

INSURES Safes and  
their Contents

### Against Burglary.

For Particulars, address the Company,  
140-146 BROADWAY, NEW YORK

# The Best Chatelaine is the Lady Racine.

## STEEL CASES & SILVER CASES.



10 LINE.

- Made in 10 Line Open Face.
- “ 11 1/2 Line Open Face and Hunting.
- “ 13 Line Open Face and Hunting.

THE SILVER CASES ARE 0.935 FINE.  
THE MOVEMENTS HAVE 10 JEWELS  
THE ENGRAVINGS ARE CHOICE.



3 LINE

### MADE IN 12 LINE OPEN FACE.

In Silver Cases only.

Case 0.800 Fine with a 6 Jewel Movement.

Expressly Gotten Up to Suit the Times.

## A GOOD Chatelaine Watch at a LOW PRICE.

Do not fail to ASK YOUR JOBBER FOR THE NEW  
12 LINE LADY RACINE in 0.800 Cases.



12 LINE



**RUBIES.**

**E. KIPLING,**

182 Broadway, New York.

ELEVATOR ENTRANCE, 2 JOHN ST.

**S. F. MYERS & CO.,**

Manufacturing and  
WHOLESALE JEWELERS,

1895 Issue, No. 39.

**OUR ROYAL CATALOGUE**

Illustrates all that is new, unique  
and desirable in

everything that pertains to jewelry.  
600 pages, size of this publication.  
Free to dealers.

SEVEN DOUBLE FLOORS.  
TWENTY-TWO DEPARTMENTS.

Myers Buildings, 48-50 Maiden Lane,  
33-35 Liberty St., New York.

**JACOT & SON**  
IMPORTERS AND  
MANUFACTURERS  
OF  
**MUSICAL BOXES** 39  
Union Sq  
New York.

**U. S. SMELTING & REFINING WORKS.**

Sweep Smelting and Assaying, Platinum in Plate and  
Wire. Chemically Pure Copper. Ore and Bullion  
Assays a specialty.

Highest prices paid for old gold and silver.  
Sole manufacturers of Phoenix Flux  
and Eureka Alloy.

**M. WOLLSTEIN,** 25 John St., New York.

**Diamond Polishing Machines.**

We build these machines complete with latest improve-  
ments also polishing wheels, tongs, doups, weights,  
shafting, belting, ventilating fans, gear-cutting, die blanks,  
etc., We do general repair work on jeweler's machinery.

**THE ARTHUR CO.,**

General Machine Works,

86 JOHN STREET

NEW YORK.



.. OUR ..  
**SPECIALTY**

The Largest Stock of  
**CHIMING**  
AND  
**STRIKING**  
**HALL CLOCKS**

ever shown.

**Chas. Jacques**

**CLOCK CO.,**  
22 Cortlandt Street,  
NEW YORK.



**B. & W. B. SMITH,**  
220 W. 29th St., New York.

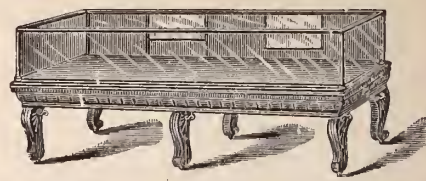

Improved Dust-Tight Counter Cases,  
Perpendicular Sliding Doors.

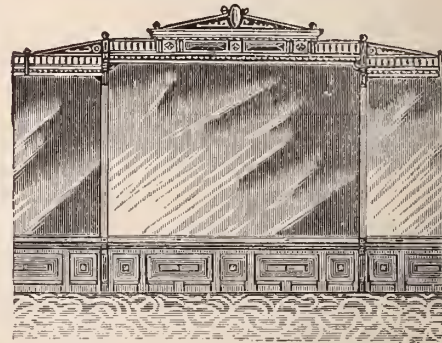

Improved Dust-Tight Wall Cases.  
Furnished with Improved Shelving and ar-  
ranged for Electric Lighting.

Sold by all whole-  
sale dealers at manu-  
facturer's price.

**A. N. CLARK & SON**  
PLAINVILLE  
CONN.

Manufacturer of the Celebrated  
**LOOP WATCH KEY.**

The Best for the Price in the World.  
CROSBY'S JEWELING TOOLS IMPROVED.

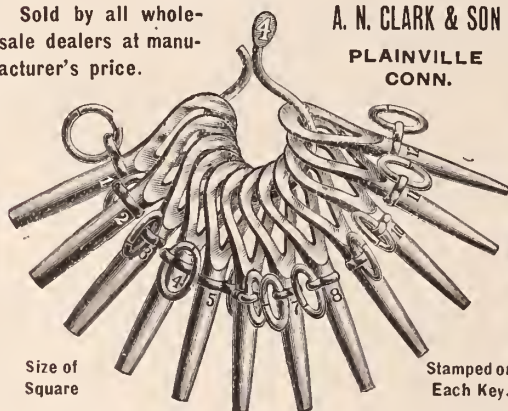

Size of  
Square

Stamped on  
Each Key.

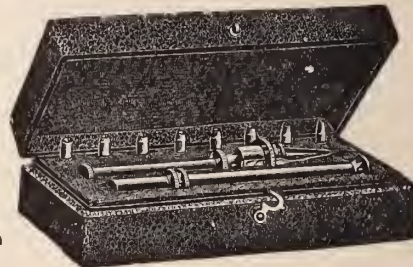

Will quote royalty or price for the manufacturing of articles of real worth.

**L. LELONG & BRO.,**

GOLD AND SILVER

**Refiners, Assayers AND Sweep Smelters,**

◁ SOUTHWEST CORNER HALSEY AND MARSHALL STREETS, ▷

**NEWARK, N. J.**

**SWEEPINGS A SPECIALTY.**

**ALBERT LORSCH & Co.,**

37 MAIDEN LANE, NEW YORK.

Branch, 167 Weybosset Street, Providence. R. I.

IMPORTERS OF DIAMONDS,

Rose Diamonds, Rubies, Sapphires, Emeralds, Opals, Moonstones,  
Fancy and Imitation Stones, Novelties.

SOLE OWNERS AND IMPORTERS OF

*The Sumatra Gem.*

REG'D. UNEQUALLED IN  
BRILLIANCY AND  
HARDNESS

HIGHEST AWARD AT THE COLUMBIAN EXPOSITION, CHICAGO, 1893.

IT PAYS TO KEEP IN TOUCH WITH TRADE AFFAIRS. For 4c. a Week will do it. **Subscribe.**

**DIAMONDS** Importers and Cutters. **L. & M. KAHN & CO.,** 172 Broadway, **DIAMONDS**

123 Park Place

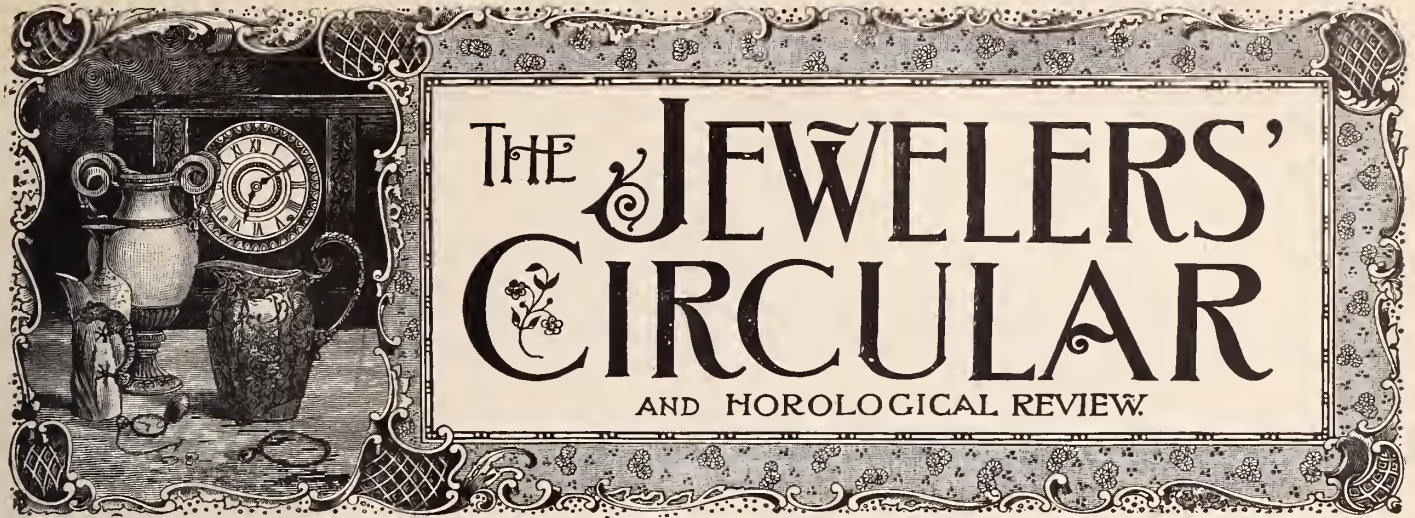

Copyright by THE JEWELERS' CIRCULAR PUB. CO.

139 BROADWAY, NEW YORK.

Entered at the Post Office in N. Y. as second-class matter.

VOL. XXIX.

NEW YORK, WEDNESDAY, NOV. 21, 1894.

No. 17.

ART IN ECCLESIASTICAL METAL WORK.

THE magnificent jeweled altar cross presented recently to St. Bartholomew's Protestant Episcopal Church, New York, was the product of the Gorham Mfg. Co. The cross, which is the gift of Mrs. Vermilye, in memory of her husband, William Edward Vermilye, is Byzantine in its design. It literally glows with jewels, which reflect the light in many colored rays from the 109 stones with which it is set. It is four feet two inches in height, and is, with one exception, the largest in the city. It is wrought in gilded brass and is of open tracery work from its octagonal base to its top. A topaz two inches in diameter rests at the junction of the arms in the center of the cross.

Jewelry in the Metropolitan Museum.

IN the gold room of the new wing of the Metropolitan Museum of Art, opened a few days ago, are many fine examples of Etruscan, Roman, and Longobardic jewelry and ornaments loaned by S. T. Baxter. The collection is full and complete, and intelligently displayed. One piece in particular, the miniature repoussé ring, from an art standpoint is likely to attract the gaze of the connoisseurs and public alike, as few antiquities have heretofore. This Etrusco-Roman gold ring is hollow; the bezel, bordered with filigree, has a relief of six figures on it in a space just five-eighths of an inch in length and three-quarters of an inch in width. The scene presents in a clear, free, yet low relief, a unique grouping, the incident being "The Judgment of Paris." The Phrygian shep-

herd is there, partly draped, seated on a rock. Behind him is earnest Eros, whisper-

fullest. Opposite sits Aphrodite, with uplifted hands, while from left to right are grouped Hera, Athene, and Hermes, standing in graceful pose, forming a tableau of exceeding interest.

Another exhibit of solid gold is the Longobard warrior ring. It is of extra large size and is set with a fine Etruscan intaglio in black and white onyx, the subject being two warriors sustaining a crippled comrade. The setting, two solid gold globules on each side of the bezel, is simple and rude in construction, though not in design or composition, often noticeable in Lombard work. A large Etruscan signet ring shows a fine intaglio in onyx, a fawn holding a goat, superior in cutting and character. An oval bezelled ring with intaglio in sard represents one of the Dioscuri leaning against a pillar, with his favorite horse beside him. Another intaglio, revolving, in rock crystal, displaying the head of a hare, upon which a bird is pecking, is rare in subject as well as finish.

Specially valuable, historically and artistically, are some of the Lombardic gold ornaments found at Chiusi, Tuscany, in a Christian tomb, as the five crosses discovered therein and a part of this collection would indicate. Their rarity of style and workmanship, attributed to the sixth or seventh century A. D., gives them great distinction. No. 170A shows the handle of a sword of solid gold, with the hilt of the steel blade rusted into a portion of the ivory scabbard, the gold surfaces being incised with fishes and dolphins. The two gold chapes or scabbard ends, part of the ivory sheath still adhering inside of the gold; a massive gold



ALTAR CROSS FOR ST. BARTHOLOMEW'S P. E. CHURCH, NEW YORK.

ing encouragement in his ears. Paris is about to bestow the Apple of Eris to the

ESTABLISHED 1842

*Samuel Little, Pres't* *Rufus B. Carr, Gen'l. Man'gr**Arthur M. Little, Treas'r*

OFFICE OF  
**THE E. HOWARD WATCH & CLOCK CO.**

**FINE WATCHES & CLOCKS**

383 WASHINGTON ST., BOSTON. 34 WASHINGTON ST., CHICAGO.

E.V. CLERGUE, Agent.

41 MAIDEN LANE, NEW YORK.

*New York!*

RETAIL JEWELERS,

GENTLEMEN--WE HAVE RECEIVED many letters from THE TRADE throughout the country from which we judge that an ERRONEOUS IMPRESSION has been given that HOWARD WATCHES cannot be obtained from Jobbers.

We therefore take this method of informing our friends, the Retail Jewelers, that any legitimate Jobber in the country can supply Howard Watches of ANY GRADE OR SIZE desired.

If your Jobber fails for any reason to fill your orders, write directly to us and we will see that you are supplied.

We have also received complaints that Retailers fail to get satisfaction when they send Howard Watches to their Jobbers for repairs, &c., and we earnestly request that any Retailer having trouble of any kind in regard to the PURCHASE, SALE or REPAIRING of our Watches, communicate directly with us.

We will gladly correspond with any dealer upon any point in connection with Howard Watches or Clocks.

The American Watch is the best watch in the world and WE HAVE ALWAYS MADE, ARE MAKING and WILL MAKE the finest American Watch.

We have a thoroughly organized repair department and will now do repair work on Howards at ACTUAL COST.

THE E. HOWARD WATCH AND CLOCK CO.

# LÉON J. GLAENZER & Co.,

80 and 82 Chambers St., New York.

—♦♦—  
**Novelties and Specialties in every Department.**  
—♦♦—

**Clocks.** Gilt, Porcelain, Enameled and Bronze, Crystal Regulators, Traveling Clocks, Hall Clocks with English Chime Movements.

**Bronzes.** Busts and Statues in real and imitation art Bronze and all the Novel Decorations.

**Lamps.** Banquet, Piano, and Princess Lamps, in Decorated Porcelain, Gilt Bronze and Enamel and other combinations.

**Fine Decorated Porcelains and Glassware.**

Sèvres Vases, Plates, Candlesticks, Inks, Flower Holders, Card Receivers, Etc. Table and Decorative Glass.

**Toilet Articles.** All kinds of Brushes, Manicure Sets, Hand Mirrors, Etc.

**Onyx Pedestals and Tables, Bric-à-Brac Cabinets.**

ALL GERMAN POTTERIES.

Dresden, Royal Bonn, Carlsbad, Teplitz, Etc., Etc.

# Novellies

.. IN ..

# Diamond Jewelry

.. FOR ..

## FALL SEASON, 1894.

RINGS, STUDS,  
LOCKETS, BROOCHES,  
LACE PINS, SCARF PINS,  
EAR RINGS, EAR STUDS,  
BRACELETS, NECKLACES,  
CORSAGE PINS,  
VICTORIAS,  
CHATELAINES,  
LINK BUTTONS,  
SLEEVE BUTTONS,  
COLLAR BUTTONS,  
CZARINAS, Etc., Etc.

Having imported a large reserve stock of Diamonds, we will not advance any of our prices at present. Dealers making their selections now will have the full advantage of the low tariff prevailing on Diamonds before the Wilson Bill went into effect.

Our stock of mounted goods is unusually complete.

You can save 15 per cent. by buying your Fall Stock now.

Write for a Selection Package.

## Cross & Beguelin

Loose—DIAMONDS—Mounted.

17 Maiden Lane,  
New York.

43 RUE MESLAY, PARIS.

buckle, with its tag, incised with a geometrical design, and another, designed with globules and cords in relief, showing on the under part three gold loops to attach it to the strap, complete the imperishable parts of the chieftains', or possibly dukes' swords.

There are several necklaces worthy of mention, among them being a brilliant series of alternating gold rings and flat beads, of rich blue glass oxidized, and from each ring hangs a pear shaped pendant of the same material. The rook and ring fastenings are still intact at the extremities. A gold necklace made with alternate cylinders and half globes has embossed center pieces showing figures of Pegasus, dolphin, oxen and Medusæ, and there is a gold chain formed of five cords of eight strands each, united into a single rope by transverse threads of gold with cylindrical clasps covered with fine filigree. An Etruscan necklace composed of garnet stars, acorns, and a fish's tooth makes a harmonious scheme of arrangement both in color and form.

Earrings are plentiful and many of them remarkable for design and workmanship. The pair of large, handsome cylindrical shapes (No. 42) shows ingenious working of the cords, granules, and filigree; in No. 34 there is some exquisite work formed of an ornamented disk of gold, with garnet center, from which is suspended an acorn of antique paste, mounted in gold, with finely wrought chains pendant on each side of it. No. 72, a massive Etruscan earring, displays a large oval ring with semi-globe attached; it is further ornamented with filigree and a star of globules. The center probably held a jewel, a pearl likely, other examples, as in No. 77, being mounted in this manner. There are plain gold circlets, others richly embossed, with raised gold work, shaped into drum forms; negroes heads in amber surrounded with filigree; fine Etruscan mosaics in a dirk with little birds in flight; Longobardic Gothic arches with gem compartments; acorn-shaped carbuncles with tassel orna-

mentations; a butterfly with enamel tracery and emerald beads, and so on.

The Etruscan gold pins are noteworthy; one group show clusters of globes covered with the finest granulation, pyramids of balls; lentil shapes, ornamented with granules and sunburst rays; garnets and sapphires with tassel and vase terminals. The most important in all phases is the Roman Fibula, once the property of the Emperor Valerius Maximianus, colleague of Diocletian. It is the only known authentic personal ornament remaining of any of the Roman Emperors. It is formed of an octagonal crossbar of gold, with a ball at each extremity. In the centre of this is another ball, from which springs the bow of the Fibula, two and one-half inches in length. In this is cut in Roman letters, HERCVLI AVGVSTE SEMPERVINCAS. Both arch and sheath show the remains of enamel in the engraved parts. There is also a unique pin in Etruscan gold, three and one-half inches long, covered with a design in the finest of granular, representing a huntsman, deer and dogs.

Among the miscellaneous articles are three funeral wreaths, one of which twelve and one-half inches long, and two and one-quarter wide. This is made with stamped golden leaves of two kinds; in the center is a flower, while the two ends are embossed in the form of owls. The other two are equally decorative in design, and effective in an ornamental sense. Mosaics of ruby glass and variegated Etruscan glass seen in a gold reliquary, heart shaped; intaglios in cornelian, niccolo sardonyx, amethysts, chalcedony, jade, green and red jasper and blackstone, with birds, horses, fawns, warriors, divinities, etc., cut upon them, help to swell not only the variety but the educational importance of the exhibit.

A burglar or burglars took advantage of the storm on the night of Nov. 2d, to rob Amsden & Kerr's jewelry store, Ashtabula, O., of silverware, jewelry, etc., said to be valued at \$1,000. A panel in the back door was bored out with a large auger.

## THE BOWDEN SEAMLESS RING

IS MADE ONLY BY

### J. B. BOWDEN & Co.,

Makers of Finger Rings of every Description.

REMOVED FROM BROADWAY AND JOHN STREET,  
TO 3 MAIDEN LANE,  
NEW YORK.



# "DELIBERATE CALCULATION"



IS ADMIRABLY PORTRAYED ON THIS FRENCH CHINA PLATE BY OUR DECORATOR,



BUT A BRIEF EXAMINATION of our CATALOGUES will convince you that he who plays a "winning game" with the Purchasing Public can do no better than select liberally from them.

— ONE CENT —

the price of the postal you send us, will bring back a book  
TELLING WHAT \$50 WILL BUY IN

**::: CUT GLASS :::**

Then there is HOLLOW WARE of every description,  
FLAT WARE, than which no better is made.  
. . . . . NOVELTIES INNUMERABLE. . . . .

## A WORD ABOUT CROWN PAIRPOINT FRENCH CHINA.

The JEWELER is not, generally speaking, an importer, yet he sells as nice a class of trade as exists. He can sell Fine China and Cut Glass as easily as Watches and Jewelry or Diamonds. Now we are importing genuine China blanks and decorating them here. We will import—you can buy from us. It will pay you well to talk with us about this.

SILVERWARE CATALOGUE No 10.

CUT GLASS CATALOGUE No. 11.

## PAIRPOINT MFG. CO.,

BRANCH STORES: 46 Murray St., N. Y.; 224 Wabash Ave., Chicago; 220 Sutter St., San Francisco.

Factories and Studio: NEW BEDFORD, MASS.

### CROUCH & FITZGERALD.

Jewelry Trunks  
and Cases,  
161

Broadway,  
Bet. Cortlandt and  
Liberty Sts.,  
688 B'way,  
701 8th Ave.,  
NEW YORK.

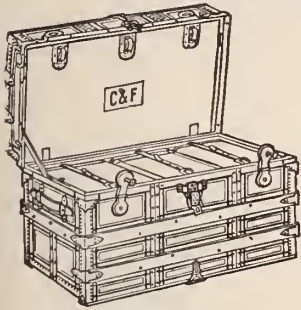

FLAT WARE AND  
HOLLOW WARE  
STAMPED

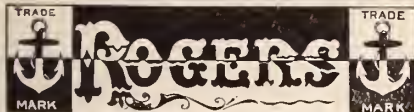

IS THE GENUINE.  
Manufactured by

WM. ROGERS M'F'G CO.,  
HARTFORD CONN.

We sell to the legitimate Jewelry and Stationery  
trade only.



CHOICE PAPERS

MAKERS OF

FINE STATIONERY

For Correspondence, Wedding and Business Use, handsomely  
boxed, specially suited to the Jewelry Trade.

18 MURRAY STREET, NEW YORK.

ALBERT BERGER & CO.

47 MAIDEN LANE, N. Y.

Spectacles & Optical Goods,

GROUND LENSES A SPECIALTY.

# R. WALLACE & SONS MFG. CO.

## SILVERSMITHS,

WALLINGFORD, - - - - - CONN.



No. 20 CUTICLE KNIFE.



No. 20 CORN KNIFE.



No. 20 NAIL FILE.

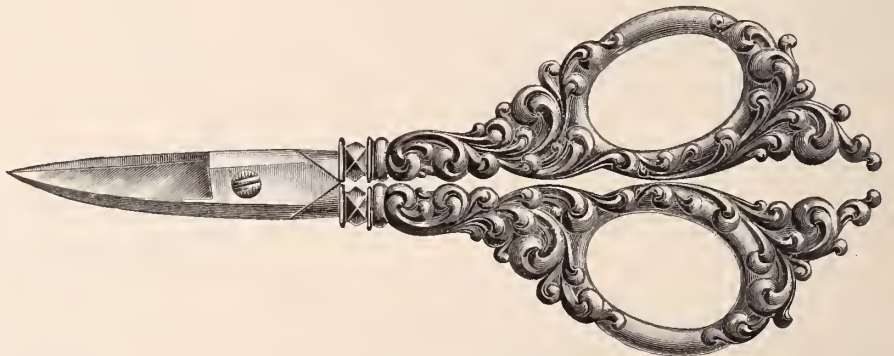

No. 20 NAIL SCISSORS.



No. 20 TWEEZERS.

NEW YORK /  
226 FIFTH AVENUE.

SAN FRANCISCO  
120 SUTTER STREET.

CHICAGO  
86 WABASH AVENUE.



## Among the African Diamond Mines.

DIAMOND MARKET IMPROVING—HOW THE DIAMOND CUTTING MOVEMENT IN AMERICA IS REGARDED—OUTPUT OF LAST YEAR.

KIMBERLEY, Oct. 10.—The market for diamonds seems to be slightly improving. The final adjustment of the American tariff law has doubtless had a steady effect, and we view with interest the intimation that arrangements, which a few months ago were only being talked of for the establishment of diamond cutting colonies in New York, Boston, Chicago and elsewhere in the United States, are now definitely settled. It is expected that the American market for rough goods will almost immediately receive a great impetus, in which case, of course, our productive industry will become appreciatively enlivened, the heavy stocks held in Hatton Garden will be got rid of, and there will be no necessity to limit the yield. At any rate that is the view of affairs here at present.

Cecil J. Rhodes is going to England next week and no doubt he will be one of the men of the fleeting hour when he reaches London.

The De Beers Co. will hold their annual meeting shortly. I learn that the value of the diamonds produced during the past year was £2,820,000. About £1,250,000 will be left for distribution among holders.

The company look forward to a more prosperous diamond market although they cannot expect a return to the old rates.

ST. GEORGE.

## Canadian Jewelers Discuss Stamping Legislation.

TORONTO, Canada, Nov. 15.—An adjourned meeting of the Toronto Retail Jewelers' Association to consider the question of the stamping of goods was held Monday evening, a number of manufacturers and wholesale dealers being present by invitation. E. M. Morphy, president of the Association, occupied the chair.

P. W. Ellis spoke at length opposing the proposition for a government hall mark on the ground that the forwarding of goods to a central point where they would be assayed and stamped would entail delay and expense. He contended that it was not the domestic manufacture of inferior goods that required to be guarded against so much as their importation, and urged that the comparatively small volume of Canadian production would not justify the government in going to the expense of establishing an assay office. The cost would in the end fall on the customer and would put the native industry at a disadvantage in competing with imported goods. They should seek legislation to stop spurious manufactures from being imported and to compel the adoption of a trade-mark by manufacturers.

E. M. Trowern thought that manufacturers should be numbered and registered and that the manufacturer's number stamped on each article would adequately protect the trade.

Thomas Roden favored the adoption of the New York law fixing the standard of "sterling" silver and making it a misdemeanor to sell as sterling goods, manufactures of inferior quality.

The general consensus of opinion was decidedly against a government hall mark and in favor of legislation fixing the standard of quality and providing for the stamping of goods by the manufacturer with his trade-mark or other distinguishing stamp. The question of organization was taken up. It was stated that the Retail Jewelers' Association was in a disorganized condition, having discontinued its meetings for about three years until called together to consider the present matter, and that it was desirable to widen its scope so as to include all branches of the trade.

On motion of Charles Spanner, seconded by Joseph Davis, the meeting organized as the Jewelers' Association of Toronto and appointed a committee comprising P. W. Ellis, Thomas Roden, Benjamin Kent, Joseph Davis, E. M. Morphy and E. M. Trowern to draft a constitution and report at their earliest convenience. The same committee was instructed to prepare and submit to the association resolutions dealing with the question of stamping goods.

 **Jno. W. Reddall & Co**  
*A Stock more attractive than ever.  
 Replete with new and artistic conceptions in fourteen karat gold.*

MAKERS OF THE MOST POPULAR LINE OF  
 SILVER MOUNTED BRACES AND BELTS.

107 HAMILTON STREET,  
 Newark, N. J.

## EXPANSION OF THE DIAMOND CUTTING INDUSTRY IN AMERICA.

IN the issue of THE JEWELERS' CIRCULAR of Oct. 31, the expansion of the diamond cutting industry in America was lengthily dwelt upon. No other movement that has transpired in the jewelry trade has possessed greater significance than this, which marks the present day. The increase in the tariff duty on cut diamonds from 10 per cent. to 25 per cent. has had an effect not calculated upon by our legislators in Washington, in stimulating on our shores this industry of cutting; we say not calculated upon, for it is the principle of protection that is at work, and it was the object of the Democratic Congress to destroy the operation of this principle as far as the United States is concerned.

Until within a few months the cutting of diamonds was an industry of little magnitude in America. J. B. Humphrey, who purchased the factory in Boston, Mass., of H. D. Morse and C. D. Foss, the former being the pioneer diamond cutter in this country, had been doing a prosperous business, with a force of about a dozen men, while Stern Bros. & Co., New York, had been giving employment to about 50 hands, nearly one half of the entire number of diamond workers in the United States.

This establishment was the only one in the country conducted on the European plan of buying large parcels of rough which were cut under the direct supervision of the firm. This firm proved that the industry under a fostering tariff could be carried on in America upon an extended scale. Other cutting establishments in New York were those of Randel, Baremore & Billings, Tiffany & Co., Chas. G. Browne, L. Tannenbaum & Co., D. De Sola Mendes & Co., Wallach & Schiele, M. D. Ferro, R. Rams-gate, J. Weiner, H. A. Groen & Bro., Norden & Co., H. Levy, and three or four

others employing but few men. There was some cutting being done in Chicago by the Stein & Ellbogen Co. Competent judges placed the number of men engaged in the cutting and polishing of diamonds at the beginning of the current year at less than 150.

Since the beginning of 1894 we have witnessed the removal from Amsterdam to Brooklyn of the large plant of Zilver Bros., the erection of other extensive plants by the Sanders & Bruhl Manufacturing Co., in Newark, by Arnstein Bros. & Co., in New York, while we learn that L. Tannenbaum & Co., and Goldsmith & Weil, New York, and Fox Bros. & Co., Cincinnati, O., are projecting factories, and that preparations are going forward for the removal of the establishments of George Kryn and S. L. Van Wezel from Holland to this country. When these establishments alone are in activity, the diamond cutting industry of America will give employment to fully 700 operatives.

Though the industry up to the beginning of this year was in almost an embryonic stage, it was gradually increasing as may be inferred from the following table of imports of rough diamonds for the 20 years ending June 30, 1893:

YEAR ENDING	VALUE.
June 30, 1873.....	\$176,426
“ “ 1874.....	144,629
“ “ 1875.....	211,920
“ “ 1876.....	186,404
“ “ 1877.....	78,033
“ “ 1878.....	63,270
“ “ 1879.....	104,158
“ “ 1880.....	129,207
“ “ 1881.....	233,596
“ “ 1882.....	449,513
“ “ 1883.....	443,996
“ “ 1884.....	367,816

June 30, 1885.....	371,679
“ “ 1886.....	302,822
“ “ 1887.....	262,357
“ “ 1888.....	322,356
“ “ 1889.....	250,187
“ “ 1890.....	513,617
“ “ 1891.....	804,626
“ “ 1892.....	1,109,429
“ “ 1893.....	1,066,586

For the eight months ending Aug. 31, 1894, the volume of imports of diamonds and precious stones uncut was \$806,468, or nearly ten per cent. greater than in the same period of the best previous year.

A certain minor proportion of this rough is of course used in the arts, for glazier's points, etc.

Commenting on the expansion of the diamond cutting industry in America, THE CIRCULAR, of Oct. 31, had the following to say, and the journal has since gleaned no definite reason why it should change its views:

“The permanent planting in America of an industry like diamond cutting will be desired by all broad minded persons, though it may in the initiative stage result in the immigration of foreign mechanics. Foreign labor, as far as diamond cutting is concerned does not compete with native labor, as the latter has necessarily been limited; and in the future, if the industry obtains a permanent footing, to which all signs point at present, these foreign workmen will give place to their American sons, and these again to their sons. It is to be hoped, if the increased tariff on precious stones does not cause the industry generally to suffer through the operations of smugglers, regarding which it is too early to fully judge, that our National legislators will leave good alone.”

## THE EQUIPMENT OF A DIAMOND CUTTING SHOP.

In the equipment of a diamond cutting and polishing plant, the main points of importance required in a diamond polishing mill are stiffness of structure to insure steady running, and ample elbow room for the operatives. When these two essentials are fulfilled it is only a question of how many conveniences can be procured for that most important part of the machine ensemble, the man. The style of diamond polishing mill now being mostly employed in the United States, has heavy iron frames and legs, as may be seen at A, Cut 1, iron cross beams B fitted with steel binding screws C and gibs D. The tables E, are of solid hard wood three inches in thickness bolted through and through with special countersunk carriage bolts, leaving a per-

fectly level, smooth surface upon which the steel protection plates F, are fastened. These are provided to give a metallic surface for the legs of the tongs to rest and slide on. An adjustable prong plate H, is set on the top of each protection plate which is used to guide and steady the tongs holding the stone.

The foregoing details practically constitute the mill proper, but, of course, there are numerous other conveniences attached for the workmen, such as drawers, lockers, water tub holders, pocket shelves for doup, foot rails, and racks for holding the grinding plates, the latter being sometimes provided with a locking bar which enables the operative at each mill to lock in his wheels.

Cut No. 2 represents the grinding or pol-

ishing plate. It is of the utmost importance that these plates be well built, as their speed when running is 2,000 to 3,000 revolutions per minute. It will be readily seen that they must be perfectly balanced. The spindles K are of the best steel with hardened points. The plates proper J are of close grained hard cast iron which, by the way, we have not yet succeeded in producing in this country, the best makers in America being compelled to import the rough castings. These spindle plates are driven with a finished and balanced iron pulley I in the foremost American shops.

Cut No. 4, shows the tong or holder into which doup L, is securely clamped by its soft copper shank. The doup in turn carries the stone, which is being operated

upon, embedded in a mixture of tin and lead, very much like the wiping solder used by plumbers, inasmuch as it sets

screws and lock nuts to take up wear and be well braced to prevent vibration. The best builders take as much care to

stated to the writer, that it is impossible to lay down hard and fast rules to cover all the details of equipping a plant and that the best mode of proceeding is to have an expert in the building and erecting of mills, approve the proposed premises and draw up a plan to scale showing the exact number of wheels that can be put in for successful operation, taking into consideration the floor beams, the rate of vibration of the building itself, the method of transmitting power, the question of light, stay guys, extra supports, etc. By this proceeding time and expense are saved to the owner of the plant, and he is enabled to start polishing in the promptest possible time.

The foregoing description of the machinery essential to a diamond cutting and polishing establishment refers to the several shops which have been fitted and are being fitted by the Arthur Co., 86 John St., New York, whose work in this line is being almost universally utilized in this country. However, a complete diamond works is not a simple place, and various additional details will be brought out in this and subsequent articles.

DESCRIPTIONS OF THE VARIOUS PROCESSES.

The process of cutting and polishing a diamond is full of interest. Wrested from the bosom of Mother earth and divested of its clay envelope, the irregular crystals, technically known as "rough," find a market first in London. Thence the major portion goes to Amsterdam, the center of the diamond cutting and polishing industry in the world, employing in that business over 10,000 workmen.

The primary operation in the larger stones is cleaving, which nearly all stones undergo in order to make them of the greatest commer-

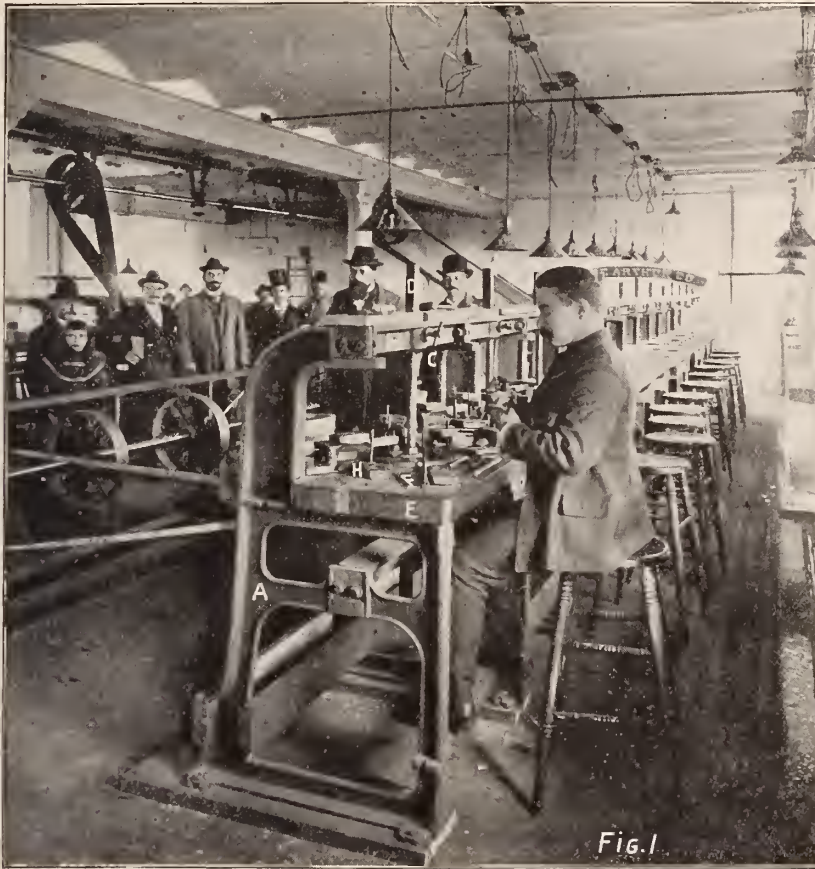

POLISHING MILL SHOWING DETAILS OF CONSTRUCTION.

slowly and thus enables the setter to adjust the stone to the exact position required while the solder is in the act of congealing. Each man usually handles four of these tongs, but some expert polishers can keep as many as six grinding away on his wheel at once, at the same time having others passing through the setter's hands.

It will readily be seen that when the work-day comes to a close, each polisher will have several stones in dousps in various stages of completion and as it would not do to remove them each night, the dousps and all are packed in iron boxes, which in turn are stowed away in the safe. This is why diamond works require a large safe with strong inside fittings. To persons not acquainted with the trade, it might sound odd when it is stated that as much as a thousand pounds of lead and brass must be stowed away in the safe of some diamond works every night, but it is, nevertheless, a fact.

Cut No. 5 is a general bird's eye view of a floor of Stern Bros. & Co.'s works, about to be formally turned over to them, by the Arthur Co.'s men.

The main line of shaft for driving the mills is usually of two inch steel supported from the floor by means of standards. See cut No. 3. These should have universal oints at the journal bearings, adjusting

prevent shake in their shafting as they do in their mills, inasmuch as the former will transmit vibration through the floor to the

mills if not carefully constructed. The most extensive builders in America of diamond cutting and polishing machinery

cial value. An expert examines the stone thoroughly, noting the formation and plan of the piece of rough. His judgment and

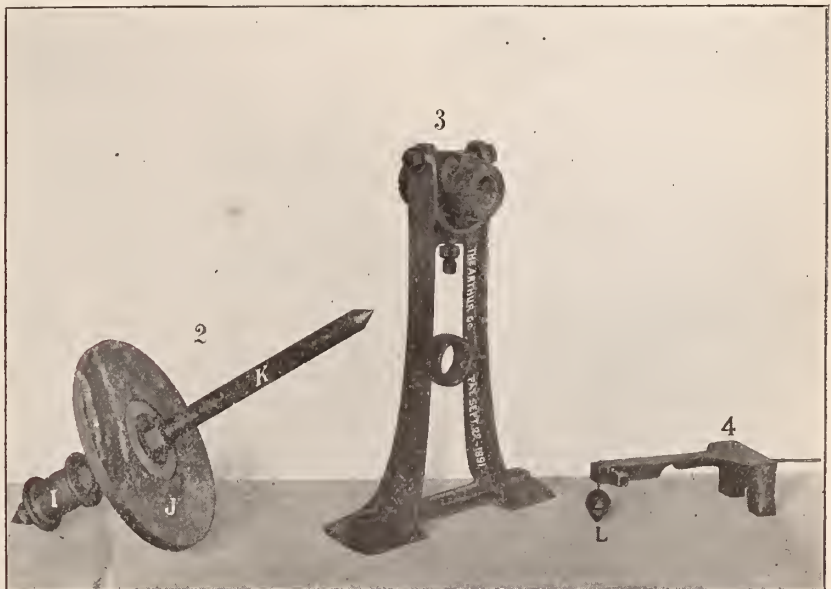

FIGS. 2, 3 AND 4, NECESSARY MACHINES AND TOOLS.

experience tell him the number of pieces into which the stone can best be cleft, and having completed his examination, the rough diamond, firmly imbedded in cement has scratched upon its faces, by means of another diamond, a line or lines along which it is proposed to make the contemplated division. With a sharper pointed diamond the first line is again gone over, and the cut made deeper, until it is con-

In its next stage, the cleft stone undergoes the cutting and begins to assume its general form as either a "brilliant" or a "rose." The old method, still in use in many European shops, is to rub together two rough diamonds, each embedded in cement at the end of a suitably shaped handle. In this country diamond cutters generally use a machine or lathe in which the stone in process of cutting is securely

state in which it is ready for the polisher.

This workman must bring judgment and experience into play in the final stage. He must determine the most advantageous method of polishing the stone, and if it have any defects, how best they may be remedied or minimized. Having determined on his first facets, the stone is embedded in molten composition metal contained in a hollow cone shaped bulb at the end of an iron arm having at the further end two small peg like projections or feet. The diamond embedded in metal and exposing only the small portion upon which the facet is to appear, forms the third "leg" of the iron when it is finally ready for the polishing. This is done on a disc or wheel of steel, about a foot in diameter and revolving at a very high rate of speed, usually about two thousand revolutions per minute.

On this disc, mixed with oil, is placed the diamond dust resulting from the cleaving and cutting, and when in motion the iron holding the diamond is fitted into its proper place at the bench in such a manner that the metal imbedded diamond rests upon the revolving disc. A polisher may have from one to half-a-dozen stones on the wheel at the same time, and must constantly watch the stones to note how the cutting progresses. In the larger shops he has an assistant, whose duty it is to remove the stone from its metal case when the desired facet has been cut, and reset it again in proper position for the next facet. As only three facets can be cut in one position, the stone must be reset again and again before it acquires the numerous angles, which, thanks to refraction, give the diamond its brilliancy, and make it, when in a completed state it finally leaves the polisher's hands, the peer of gems.

STERN BROS. & CO.

The diamond cutting works of Stern Bros. & Co. are located at 29 and 31 Gold St., New York, where they occupy three large commodious lofts, excellently lighted and

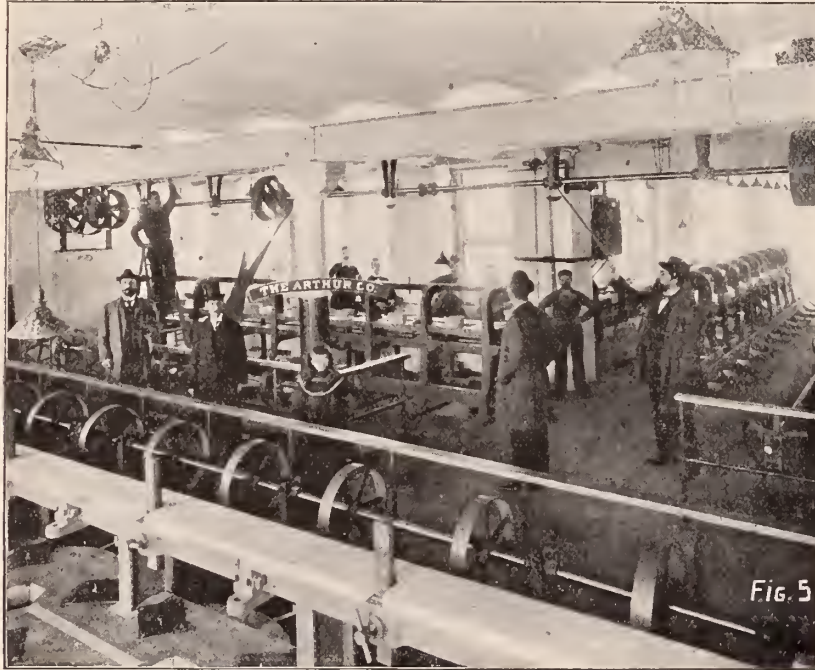

CUT 5—GENERAL VIEW OF STERN BROS. & CO.'S FACTORY.

sidered safe to deliver the final blow which will separate the stone. A fine steel blade is placed upon the scratch, and with a sharp quick tap upon the blade, the experienced cleaver finds his rough neatly split in twain.

held in a rapidly revolving chuck, while another rough diamond similarly fastened in an adjustable chuck and guided by the workman, is brought in contact with it. By attrition, the stone gradually assumes shape and outline and is soon brought to a



**W**ITH the increased facilities at our command, and since the removal to our new Factory, we are now better prepared than ever to supply the trade with the high grade of goods required by the American market, at prices which will interest the most critical buyers.

**ARNSTEIN BROS.,**

Cutting Works:

45 John Street.

37 Maiden Lane,

NEW YORK.

provided with all modern factory conveniences. The lower loft, which is this firm's latest acquisition, rendered necessary by increasing business has just been fitted up with the latest modern machinery by the Arthur Co. This factory was the first in

Two views of the shop of the Sanders & Bruhl Mfg. Co. are given herewith—one showing the installation of machinery, and the other a row of cutting machines. The works occupy the old factory of Tiffany & Co., in Newark, N. J., which forms a part

are 40 operatives engaged in the works.

In the official management, Ludwig Lilienthal who for about 25 years has been a member of the firm of Bruhl Bros. & Co., is the American manager, while in Europe Doris Sanders looks after the company's interests. The United States Diamond Cutting & Polishing Co. which as above stated are the selling agents for the Sanders & Bruhl Mfg. Co. have offices in the Hays building, 21-23 Maiden Lane.

(Series to be continued.)

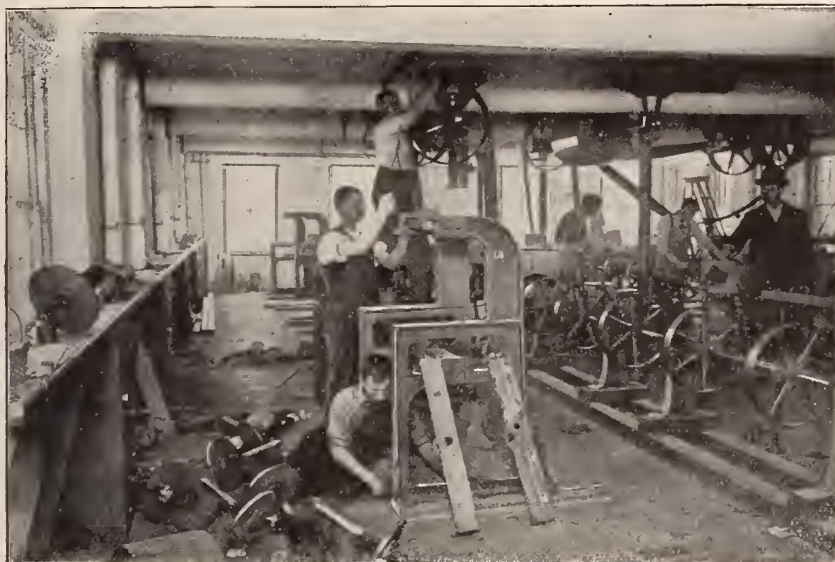

ERECTING DIAMOND MILLS IN THE SHOP OF SANDERS & BRUHL MFG. CO.

this country to introduce the European shop system and cut successfully on a large scale. About 100 men are employed and the capacity of the shops is 80 mills. The principal office of the firm is in the Sheldon building, corner John and Nassau Sts., New York.

THE UNITED STATES DIAMOND CUTTING AND POLISHING CO. AND THE SANDERS & BRUHL MFG. CO.

On November 5 the United States Diamond Cutting and Polishing Co. were incorporated under the laws of New York State, to import, sell, cut and polish diamonds in New York city. The capital stock is placed at \$10,000, and the directors of the company are: Ludwig Lilienthal, Emil R. J. Woywoth, and Julius Goldman, of New York city; Doris Sanders, of Amsterdam, Holland; and Paul Bruhl, of Paris, France.

On the same date the Sanders & Bruhl Mfg. Co., of Newark, N. J., were incorporated under the laws of the State of New Jersey, with a capital stock of \$100,000 in single shares of \$50, to "cut, polish, and purchase and sell diamonds." The promoters of this enterprise are: Ludwig Lilienthal and Emil R. J. Woywoth, of New York city; Doris Sanders, Amsterdam, Holland; Paul Bruhl, Paris, France; and Chas F. Wood, Summit, N. J.

These two corporations are essentially the same concern, the separate incorporation in New York being desirable in view of the taxation placed upon foreign incorporations by the revised statutes of New York State.

of the Carter, Sloan & Co. factory building, corner of Park and Mulberry Sts. The shop was opened about four weeks ago, the equipment being a rapid piece of work of three weeks' duration, of the Arthur Co., who built one-half of the machinery and erected all of it. The machinery is nearly all of American manufacture, and contains several mechanical improvements, as specified

#### Dunning With Postal Cards Costs Keating Dearly.

CHICAGO, Ill., Nov. 17.—James F. Keating, a dealer in rhinestone goods under the name of the Rhinestone Jewelry Co., was sentenced early in the week by Judge Allen to pay a fine of \$100 and the costs of the prosecution. The case was brought before the United States Court on the charge of using the mails for fraudulent purposes.

It seems Keating mailed packages of his jewelry to people in different sections of the United States, but not desiring to appear in the rôle of philanthropist he shortly after sent a circular and price list calling on his involuntary customers to remit. On failure of the recipient to send the money the process of collection was continued by means of dunning postal cards. He might have found smooth sailing yet but for the fact that J. L. Stahl, of Salisbury, N. Y., objected to receiving threatening postal cards and was willing to push the case.

There ought to be no compunction on the part of dealers in turning over threatening postal cards to the nearest United States

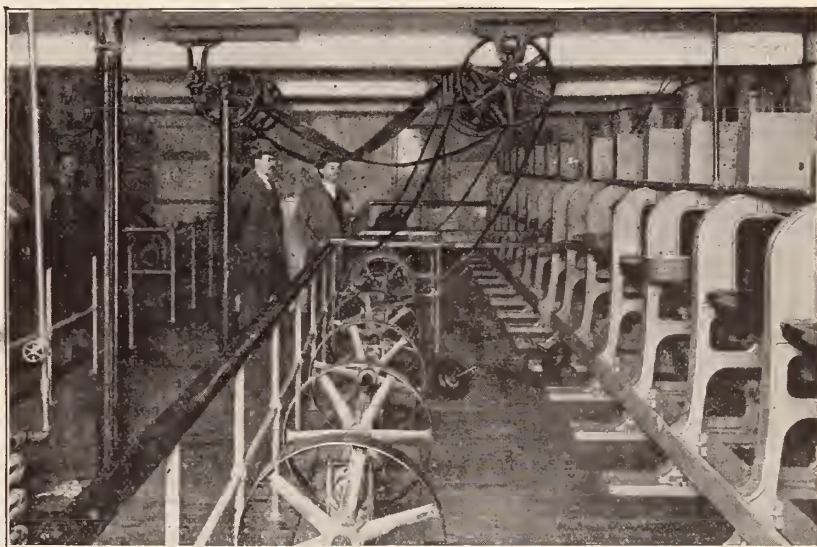

FLOOR OF SANDERS & BRUHL MFG. CO. WORKS.

in the preceding chapter of this article.

In the shop L. Bessie, who has had fifteen years experience in the business abroad, is the superintendent and cleaver. The shop accommodates 80 machines and is excellently lighted. At the present writing there

Commissioner and rooting out this method of conducting business.

R. A. Jiming, Peoria, Ill., has taken charge of the watch repairing part of the Trigg Jewelry Co., Albuquerque, N. M.



# Perfect Construction

— AND —

## SUPERIOR FINISH

MAKE OUR PRODUCTIONS OF  
HIGHEST GRADE.

JEWELERS and  
FANCY GOODS DEALERS  
will find in our new line of  
**Art Metal Goods**

many articles specially adapted  
to their trade.



### The Finest Line of Banquet Lamps EVER PRODUCED.

Fitted with the Celebrated "B. & H." Burner.

New and Attractive Designs and Finishes. Sure to be Ready Sellers.

We will send you our Little Book, giving more information, if you desire, and will be glad to have you visit our Salesrooms and see the Goods.

## BRADLEY & HUBBARD MFG. CO.,

NEW YORK, PHILADELPHIA, BOSTON, CHICAGO,  
28 PARK PLACE 710 BETZ BLD'G. 160 CONGRESS ST. 204 MASONIC TEMPL.  
TO 21 BARCLAY ST. FACTORIES AND OFFICES, MERIDEN, CONN.

## Now that we have touched bottom

And business generally is improving every GOOD RETAIL JEWELER should make his stock attractive and so invite customers. He can buy nothing more sure of sale than



1007



of standard quality, at moderate cost, and of new and taking styles. If not called upon by our travelers send your orders direct to

**M. B. BRYANT & CO.,**  
10 MAIDEN LANE, NEW YORK.

### Watch Clubs Adjudged to be Perfectly Proper in Connecticut.

HARTFORD, Conn., Nov. 14.—William J. Pierce, the Hartford agent of the Standard Jewelry Co., Meriden, who was recently arrested in this city for trying to form a watch club, and who was arraigned before Judge Barbour in the Police Court yesterday, was acquitted to day.

Judge Barbour stated that he could see nothing criminal in the business of watch clubs as conducted by this company, but rather that the clubs are a benefit to the community. This decision is directly in line with the legal opinion given by Judge Platt to the Common Council in relation to the clothing clubs.

### The Bridgeport Silver Plate Co.'s Building Project.

BRIDGEPORT, Conn., Nov. 14.—Among the permits just granted by the building commissioners was one for a factory on Mountain Grove St., issued to W. H. and T. E. MacFarlane. The Messrs. MacFarlane are proprietors of the Bridgeport Silver Plate Co., a concern which started in business on Golden Hill St., in '87 and has for three years past been located in the old organ factory. They employ 75 men and have outgrown their quarters and are compelled to build a new and more convenient factory.

The factory when completed will consist of one three-story building 100x40 and a one-story building 80x20. Ground has already been broken for the structures at the corner of Mountain Grove St. and Railroad Ave. and it is expected that they will be completed by Jan. 1. The force of employes will be increased from 75 to 150. The concern heretofore dealt only in plated ware, such as mirrors, coffin trimmings, and novelties, but when the new factory is occupied they will go into the manufacture of hollow ware.

### WOOD & HUGHES, STERLING SILVERWARE MANUFACTURERS

New York Agents for the Derby Silver Co.'s  
FINE QUADRUPLE PLATED WARE,  
No. 16 JOHN STREET, NEW YORK.  
206 Kearney St., San Francisco, Cal.  
HASKELL & MUEGGE, Agents.

### WHITE'S EYE SHADE. W. D. WHITE & SON MANUFACTURERS OF



Spectacle and Eye Glass  
CASES

90 SOUTH STREET, BOSTON.

Special Cases made to order for Optical Trade. Cases for Trial Lenses. Opera Glasses recovered, etc. Chatelaine Spectacle Cases Metal Round Leather Cases for combs, scissors, etc. Over forty kind of cases manufactured.

## AIKIN, LAMBERT & CO.,

CHICAGO BRANCH: 103 State Street.

No. 19 MAIDEN LANE, NEW YORK.

Manufacturers and Exporters  
Gold Pens, Holders, Pencils,



Toothpicks and Novelties.

# MERCANTILE



# FOUNTAIN PEN.

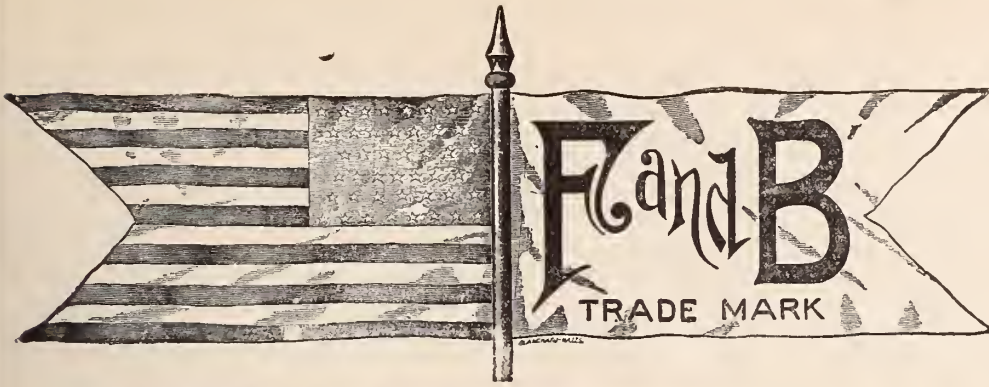

# FOSTER & BAILEY,

100 RICHMOND ST.,

PROVIDENCE, R. I.

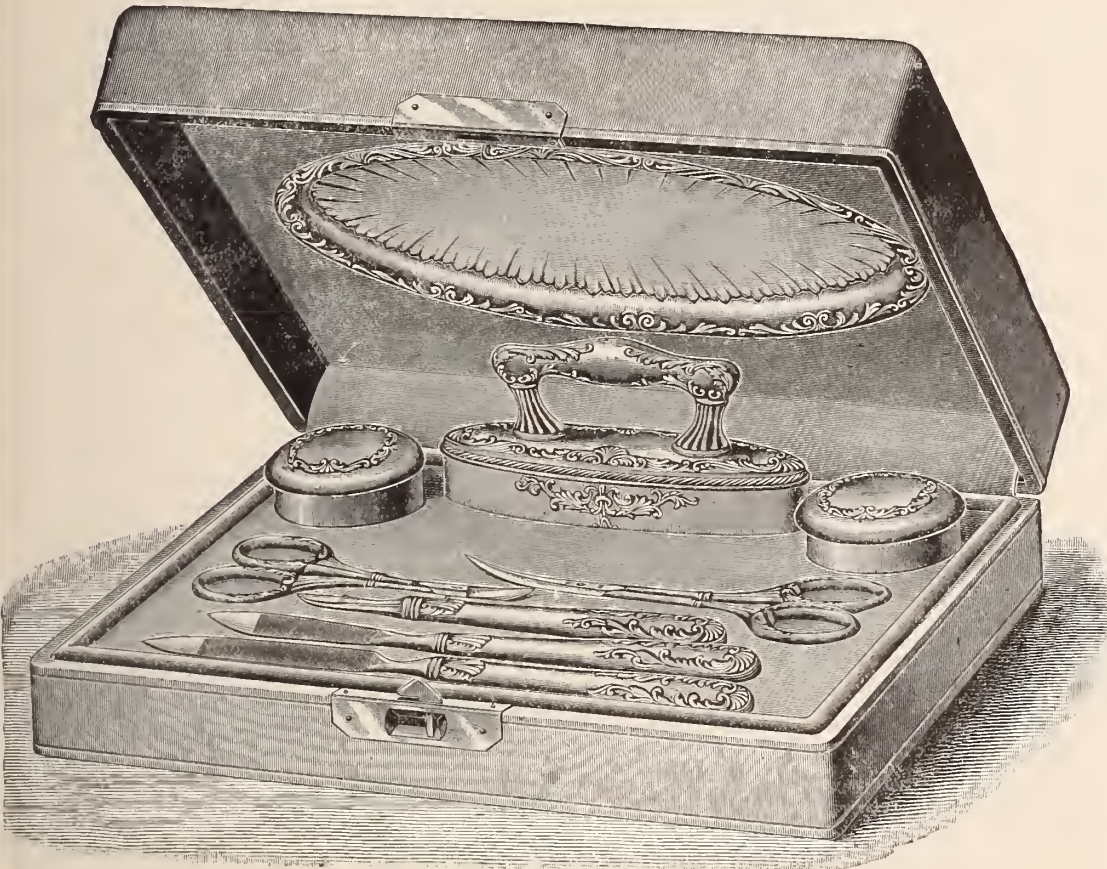

ONE QUARTER SIZE.

Be sure and see the Manicure Goods that we have just put out. This cut shows a set in a nice box, lined with Chamois, and is a quarter size. **Beautiful Goods.** The steel parts are made by the famous **Henckles**, of Germany, and are considered the best in the world. We make the goods in Sterling Silver and also in Tenth Gold, and at such a low price! The goods are boxed just right, so that a traveler can carry them in a trunk, and take up but little room. Set without the large tray and buffer box and others with less pieces at low prices.

No. 1, 2, 3 is Sterling Silver. No. 4, 5, 6 Tenth Gold. Every piece is numbered and can be ordered separate, and at prices that will sell the goods. We make a specialty of Sterling Silver Novelties, comprising

Match Boxes, Manicure Articles, Shoe Buttoners, Embroidery Scissors, Garters, Paper Cutters, Ladies' Seals, Etc. All  $\frac{925}{1000}$  Fine.

### Rolled Plate Watch Chains

Our Chains can be safely sold to the best trade, and guaranteed as superior quality. No chance of poor quality where chains are stamped F. & B.

### Gold Vest and Dickens Chain

Soldered with 10 K. Gold Solder. Will assay 1-10 Gold.

### Chain Mountings

We are headquarters, and make everything in this line.

### "Mount Hope" Buttons

Superior to any button in the world. Easy to put in and take out of the cuff.

### Solid Gold Locket

With Diamonds and without. This is a beautiful line and solid through out.

### Link Buttons

We are making some very pretty styles in Roman, chased, engraved and plain, with and without stones, Sterling Silver and Rolled Plate.

### Locket and Charms

We make them in endless variety.

### Sterling Silver Goods

Match Boxes, Manicure Articles, Shoe Buttoners, Embroidery Scissors, Garters, Paper Cutters, Ladies' Seals, and various novelties, all  $\frac{925}{1000}$  fine.

### Bracelets

Curb Bracelets in all sizes, with padlocks and snaps, chased and plain polished, Roman, rolled silver plate and sterling silver. We make padlocks with keys and also with a push snap, which are very popular.

### Neck Chains and Lorgnette Chains

### Pins

Lace and Cuff Pins, with gold fronts, engraved; also trimmed pins, Scarf Pins, Baby Pins with Chain. Also Baby Buttons with Chain, Sword Pins with Scabbard and Chain. Belt Pins.

### Glove Buttoners

### Crosses

Four sizes of gold filled in plain, engraved, and set with stones.

### Earrings

A nice line in engraved and trimmed. Eye Glass Chains in Gold and Plate. We received four awards and a medal at World's Fair.

## If You are In business For Profits

You should sell  
the new

### "Princeton" Watch

and not be obliged to  
compete with outsiders  
nor have your customers  
tell you prices.

### Three grades:

16 size Nickel, Hunting  
and Open Face—15, 16  
and 17 Jewels, Adjusted,  
Patent Regulator.

Superior to any,  
and at less price.

Ask your Jobber.

Price Lists with full  
information mailed to  
regular jewelers upon  
application.

A. C. SMITH WATCH CO.,  
Manufacturers,

177 BROADWAY, - NEW YORK.

## Jules Jürgensen

OF COPENHAGEN.

The reputation these watches have maintained for  
**Fifty Years** has never been equalled, being made  
on strictly scientific principles and no expense spared to  
give the **Best** results in mechanism and timekeeping  
qualities.

SOLE AGENTS,

John C. Hyde's Sons,  
NO. 22 MAIDEN LANE

### Another Batch of Diamond Workers Come to these Shores.

Immigration authorities last week caused 26 passengers on the *Friesland* which arrived Nov. 13th, to be detained, on the ground that they were under contract to work for diamond cutting concerns in the United States.

The information which caused the detention of the diamond cutters came from the Treasury Department at Washington to Dr. Senner. Edward Downes, the United States Consul at Amsterdam, had sent to the department the translation of an advertisement which had appeared in the *Algemeen Handelsblad* of that city, on Oct. 2, addressed to diamond polishers, who were informed that steady work and good wages awaited diamond cutters and polishers who were desirous of emigrating to this country. Two addresses were given in this city where workmen could apply for employment.

The information from the Consul was subsequently supplemented by a notice that Solomon and J. A. Hudmacher, two diamond cutters, had left Antwerp on Nov. 3 in charge of 24 journeymen diamond cutters, polishers and splitters. When the *Friesland* arrived the inspectors found the Hudmacher brothers in the first cabin and the rest of the party in the second cabin. Some of the men are married and have families. They were all comfortably clad and each had some money.

The entire party were taken to Ellis' Island where the men denied they were contract laborers, but said that, owing to the stagnation of their trade in Amsterdam, they had emigrated to this country in the hope of finding remunerative employment.

The Special Board of Inquiry, Wednesday, made a thorough examination of the cases of the detained men.

J. A. Hudmacher made affidavit that he had conducted a diamond polishing and

cutting shop in Amsterdam, but owing to the stagnation of business he had been compelled to give it up. He had turned all his possessions into cash and hoped to be able to engage in the diamond business here. He denied under oath that any of the detained immigrants were under contract to him, or any one else as far as his knowledge went. Solomon Hudmacher, his brother, made affidavit that he had formerly made good wages as a diamond polisher in Amsterdam, but he had been out of work for a long time and had come to America to seek employment. He denied that he was under contract to any one. While they were positive in their denials that they had anything to do with bringing the party over to this country, they could not account for the fact that so many of the same trade came over together in the same steamer.

As the board could find no evidence strong enough to hold them, all the men were released.

### Interesting Storage Case Decided Against Tiffany & Co.

An interesting suit involving a novel point, was tried before Judge Barrett and a jury in the New York Supreme Court circuit Nov. 13th. It was the action brought by Mrs. Myrtella F. Hart, to recover from Tiffany & Co., the value of a trunk full of articles which she stored with Tiffany & Co., and which they afterward delivered to her husband, from whom she had separated. The trunk was sent to Tiffany's July 1, 1891. The Harts were then living in New York. On the receipt given to Mrs. Hart for the trunk was a printed notice stating that the receipt must be given up before the trunk could be surrendered. Soon after the trunk was stored the Harts went to Charleston. From there Mr. Hart wrote to Tiffany & Co. for the trunk, and they sent it to him Feb. 9, 1892. In April, 1892, Mrs. Hart demanded the trunk and in reply Tiffany & Co. showed her her husband's receipt for it. She then brought this suit.

ESTABLISHED 1843.

Highest Awards in Every Competition

LEROY W. FAIRCHILD & Co.,  
3 Maiden Lane, New York City,

Gold Pens, Gold and Silver Pencils and Pen Cases,

The Handsomest and Cheapest Line of Goods in the Market.

WORKS: 3D AVENUE AND OGDEN ST., NEWARK, N. J.



Mrs. Hart testified that she had letters in the trunk which she intended to use in an action for divorce against her husband. Fearing that he might try to get these letters, she says she wrote to Tiffany & Co. telling them not to give up the trunk to her husband. The firm denied receiving such a letter. She alleged that the contents of the trunk were worth \$2,500, exclusive of the letters, consisting of silver, part of her trousseau, and point lace of much value.

Several experts, including employes of Tiffany & Co., testified as to the value of the contents of the trunk. The deposition of Hart, taken in Charleston, said that experts who had examined the contents of the trunk in Charleston had valued them at \$427.75. He admitted having the trunk and said his wife had never demanded it of him.

The point was also raised, but without avail, that by the law of South Carolina wedding presents belong to the husband. Justice Barrett said that if a person can give to a husband what is confided to him by the wife, he can give it to any other relative or to a stranger. The jury found a verdict awarding Mrs. Hart \$1,030, with interest, and an extra allowance of 5 per cent., making the verdict in all \$1,199.50.

#### Organization of Retail Jewelers' Association of the State of Massachusetts.

WORCESTER, MASS., Nov. 15.—The Retail Jewelers' Association of the State of Massachusetts was organized in this city Wednesday at a largely attended meeting of the members of the trade which was held in the Board of Trade rooms. The organization was conducted by Arthur S. Goodman, of Philadelphia, president of the National Retail Jewelers' Association.

There were present at the meeting the following Massachusetts jewelers: Charles M. McFarland, Bruce & Chapin, Herman Luke, Nelson H. Davis, J. P. Weixler, all of Worcester; R. E. Eldridge, Edward F. Lilly and Charles W. Wilcox, of Milford; F. E. Ladd, Eldridge & Penny, M. F. Robinson & Son, F. A. Hubbard of Springfield; W. W. Newcomb of Fitchburg; H. A. Hewey, of Winchendon; Joseph F. Bartlett, L. T. Wilner and G. S. Strout, of Clinton; G. O. Foye & Son of Athol; J. A. King, of Southbridge; Katelle & Son, of Boston; J. H. Connor, of Lynn; J. J. Frigault, of New Bedford; C. P. Forbes, of Greenfield; O. L. Brown & Co., of Hopkinton; S. J. Howell, of Orange; G. W. Tewksbury, of Westboro; F. W. Barnes, of Uxbridge; W. W. McAllister, of Whitinsville; G. W. Sawyer, of Spencer, and T. E. Dickinson, of North Adams; Monroe, Carter & Co., Southbridge; J. N. McVine, West Gardner; E. Chandler, West Gardner; C. W. Bergman, Webster, G. A. Bailey, West Brookfield; Frank Knowlton, Worcester; England & Leavitt, Worcester; M. F. Tallman, Worcester; Chas. Weber, Fitchburg.

The meeting was called to order at 2 o'clock by Mr. Goodman, who made a lengthy address, in which he pointed out the advantages of the formation of a State association to affiliate with the National organization. He spoke of many abuses and impositions which the jewelers had to suffer, but which might be averted by affiliation with organizations of this kind. Mr. Goodman gave the history of the National order. He stated advantages that would be derived from organizing a State association to affiliate with the National organization.

It was resolved, after Mr. Goodman's address, to organize immediately. In accordance with this resolution, Mr. Goodman finally instituted the association, with the charter members from the above list.

It was resolved to call the organization "The Retail Jewelers' Association of the State of Massachusetts," to be regarded as a branch of the National Association. Those who were present are members of county associations, and they signified the intention of the county association members to join the State organization.

Letters were read from other jewelers in the State, who said they would join if a State association were formed.

The officers were elected as follows: State president, R. E. Eldridge, Milford; vice-president, F. E. Ladd, Springfield; secretary and treasurer, W. W. Newcomb, Fitchburg. President Eldridge was authorized to appoint five directors, who, with the three officers, will constitute the di-

rectorate.

The meeting adjourned at 6 P. M., to meet again at the same place, January 3.

In the meantime organization will be perfected, and circulars will be sent to all the retail jewelers in the State.

Mr. Goodman left after the meeting to see the jewelers in Lynn, Lawrence and Lowell, in the interest of the new State organization. He will probably go, subsequently, to Providence.

#### Do This Couple Belong to the Utica Sneak Thieving Gang?

TROY, N. Y., Nov. 15.—A neatly attired man entered M. Timpane & Sons' jewelry store shortly before noon Tuesday and asked to see diamond rings. A member of the firm showed the stranger a tray of diamond rings, which were carefully examined. Miss Mary Shaw, who is connected with the store, suspected the man and counted the rings in the tray. She found that a \$70 ring was missing, and that an inferior diamond ring valued at \$20 had been put in the place. The stranger attempted to push the \$70 ring under a plush mat on the case. Another man, supposed to be an accomplice, hurriedly left the store about this time. The cheap diamond ring was kept by Mr. Timpane, and the stranger followed his companion.

The same two men entered E. Marks' jewelry store after leaving Timpane's. The stranger who examined the rings in Timpane's store asked if he could have a

# NOVELTIES

IN

ROYAL WORCESTER,  
COALPORT, MINTON,  
POINTON, DOULTON,  
CROWN DERBY, Etc.

FRENCH FANCY GOODS, REAL <sup>AND</sup> IMITATION BRONZES,  
CLOCKS, PEDESTALS, ETC., ETC.

GILT REGULATORS

With Plain, Pierced, Pearl and Rhine Stone Dials.

THE CHOICEST LINE IN THE COUNTRY.

## LE BOUTILLIER & CO.,

860 BROADWAY,

Northeast Corner of 17th Street,

NEW YORK.



lady's gold watch repaired. His companion, a young man handsomely attired, asked to see a set of ladies' diamond earrings and pin. Both men said that they would call again, and left the store without making any purchases.

J. M. Rockwell, employed as a jeweler by M. Timpane & Son, followed the men down River St. He took hold of the one who attempted to take the \$70 ring, and told him he must go to police headquarters. The fellow made no resistance, and went along with his captor. The stranger gave the name of Henry Morris. While acknowledging that he had been in Timpane's and Marks' stores, he denied that he had a companion and that he owned the inferior ring found in the tray. Morris said that he was a veteran and was a traveling man out of employment. It is suspected that both men are jewelry store sneak thieves, and that they were the men who stole jewelry from Wells' store in Utica, Oct. 27. Morris' companion wore a peculiar ring, which tallies in description with a ring which was among the stolen goods.

**The American Watch Tool Co. Incorporated.**

WALTHAM, Mass., Nov. 16.—The American Watch Tool Co., of Waltham, have incorporated with a capital stock of \$40,000 in single shares of \$100, for the manufacture and sale of tools and machinery for watchmaking and other mechanical work.

The promoters are Henry N. Fisher, John E. Whitcomb, Jas. A. Davis, and J. Albert Brackett.

**C. H. Solomon Fails After a Long Career.**

MACON, Ga., Nov. 16.—C. H. Solomon, jeweler, of this city, has made an assignment. The liabilities are \$14,000 and assets \$20,000; preferences \$7,000.

Mr. Solomon has been in the jewelry business 23 years.

**The Assets and Liabilities of the Weber Co., Milwaukee.**

MILWAUKEE, Wis., Nov. 16.—Assignee Alfred Church, of the Weber Co., jewelry dealers, has filed a report showing the assets and liabilities of the company. The assets are \$4,999.12 and liabilities are \$9,904.11.

Of the accounts scheduled as due the company \$3,293.93 are stated to be of no value leaving only \$234.34 of book accounts that are stated to be collectable.

**Five Executions Issued Against William H. Gilmore.**

UTICA, N. Y., Nov. 15.—On five executions issued against William H. Gilmore, jeweler, doing business at 168 Genesee St., the Sheriff levied upon the stock in the store. The executions aggregate \$13,812.49. One is in favor of W. K. Gilmore, father of William H., for \$8,984.60, one in favor of Clara Gilmore, a sister, for \$1,035.60 and the remaining three in favor of the Utica City National Bank for \$1,853.48, \$1,563.34 and \$375.47 respectively. The Sheriff has taken possession and will sell the stock to-morrow, beginning at 10 A.M.

Mr. Gilmore has been in the jewelry business in Utica for the past six or seven years.

**Double Murder in a Mississippi Town.**

LULA, Miss., Nov. 16.—Jacob W. Harman, Mayor of this town, and Henry Lawrence, jeweler, were assassinated in the street at noon to-day by John W. Boyd, a plantation overseer, and his younger brother, "Bob."

Mayor Harman and the elder Boyd had a dispute a year ago, when several shots were fired, and since that time bad blood had existed between them. The mayor met John W. Boyd on the street yesterday afternoon, drew his pistol and beat him over the head with it. The Boyd brothers came into town armed with rifles yesterday.

As Harman and Lawrence walked up the street to dinner at noon the Boyds confronted them and opened fire. Harman drew his revolver and fired a couple of shots ineffectually. Both the Mayor and Lawrence were killed on the spot.

The elder Boyd escaped on horseback and the younger on foot. They sent word they would surrender to the sheriff, but to no one else. The two men killed were each 35 years old. The elder Boyd is 25 and his brother 18 years old.

**A. L. Right's A. P. A. Sympathies not Fully Endorsed.**

ST. LOUIS, Nov. 15.—At 1613 Franklin Ave. is a jewelry store. At night the brightly lighted show window silhouettes with clean, cut distinctness the letters forming the name of the proprietor, A. L. Right. But with a certain class of citizens events have already proven with a similarly clean cut distinctness that he is not "all right."

One of the events referred to occurred about 6.30 o'clock a few evenings ago. The event was in the shape of a brickbat, which came crashing through his show window. In the before mentioned show window is an A. P. A. sign, and it is understood that A. L. Right admits his connection with that organization, and takes pleasure in displaying the aforesaid sign. His pride in the A. P. A. is liable to make a martyr of him not only in the loss of his property by the brickbat smashing process, but in the matter of personal injury, as the brickbat thrower is liable to hurl one at the proprietor some evening under the cover of darkness.

This is the third time that A. L. Right's brightly lighted show window and his A. P. A. sign have placed him in the position of being all wrong. The matter has, on every occasion, been reported to the police. But as the brickbats have always been thrown under the cover of darkness, the missile thrower has never yet been seen.

**OPPENHEIMER BROS. & VEITH,**

OFFER TO THE TRADE



Cut by them according to scientific principles, at prices far below imported goods of the same quality.

NEW YORK, 35 MAIDEN LANE.

Amsterdam, 2 Tulpstraat.

London, Eng., 27 Holborn Viaduct.

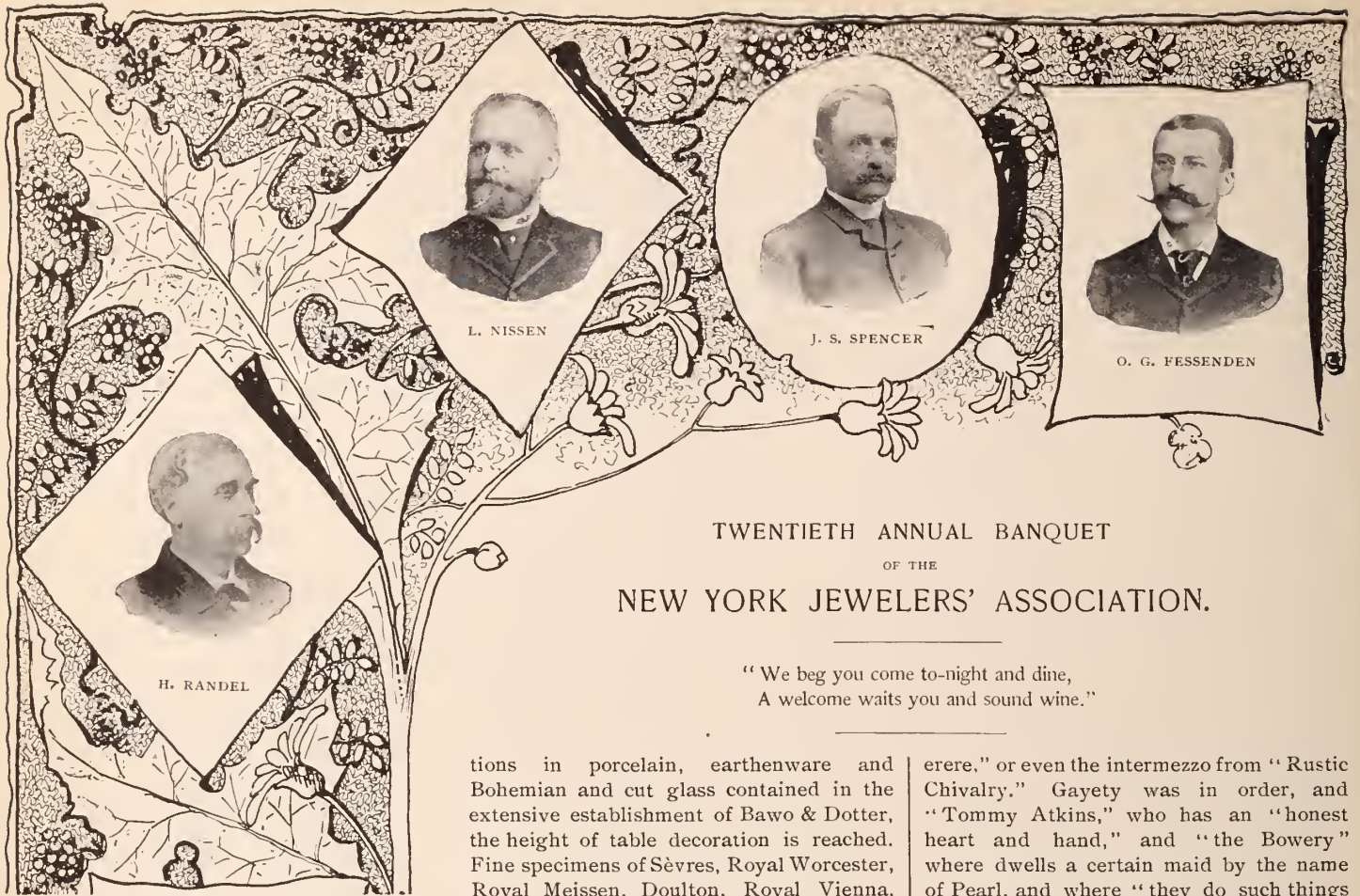

TWENTIETH ANNUAL BANQUET  
OF THE  
NEW YORK JEWELERS' ASSOCIATION.

"We beg you come to-night and dine,  
A welcome waits you and sound wine."

**A**FTER elaborate preparations, the 20th annual dinner of the New York Jewelers' Association transpired in the elegant banquet hall of Delmonico, 26th St. and Broadway, New York, on the night of Nov. 15. Previous similar occasions were characterized as glorious gems, but this last manifestation of good cheer and bonhomie was a veritable sunburst of diamonds. The convention of bon vivants was a pronounced success in all the elements that go to make up such an affair, and the gentlemen who supervised the various details may feel assured that their labors will be awarded with the fullest meed of praise by the organization.

In this assemblage were many of the representative jewelers of America, men who have created a national art in the working of gold and silver, and who have founded an industry that rears her head as high as do her sisters in the countries of Europe and the Orient.

The banqueters were seated at six tables arranged in parallel order, the invited guests' table being at the head of the room on a raised platform. The decoration and equipment of these tables evidenced the highest artistic discrimination, being beyond all precedent the richest Delmonico's has been favored with. Previous occasions may have called forth rich productions of silver, but when the most select wares of the two true silversmithing houses of George W. Shiebler Co. and Dominick & Haff are combined with the best produc-

tions in porcelain, earthenware and Bohemian and cut glass contained in the extensive establishment of Bawo & Dotter, the height of table decoration is reached. Fine specimens of Sèvres, Royal Worcester, Royal Meissen, Doulton, Royal Vienna, Royal Bonn, Pointons, Cauldon, Teplitz, Austrian Faience, and other famous wares intermingled with perfect expressions of repoussé silver in loving cups, vases,

ere," or even the intermezzo from "Rustic Chivalry." Gayety was in order, and "Tommy Atkins," who has an "honest heart and hand," and "the Bowery" where dwells a certain maid by the name of Pearl, and where "they do such things and they say such things," were the arias which tuned a light heart for a lighter head.

The body of festive men were treated to an unusually long list of speeches, though some of the speakers evidently coincided with Shakespeare when he remarked that "brevity is the soul of wit," for their discourses were brief though pertinent and interesting. The occasion may have been well termed the Convention of Mayors, for Strong, he who will soon be the administrator of New York, Schieren, of Brooklyn, and Lebkuecher, of Newark, were present and were an eloquent personification of the political reform movement of the past two years. Politics, however, were barred, for it was understood there were a few Democrats in the assemblage, and the jewelers of America are widely noted for their charitable instincts. The jewelers once more drank in the eloquence of Frederic Taylor whose acquaintance they made the year before. The Rev. Dr. Brown again proved himself eloquent and earnest. In fact, all the speeches were so good that it were invidious to discriminate.

In the reception-room was a large bronze bust of Charles L. Tiffany, by Paulding Farnham—a fine work in modeling and a fitting and lasting tribute to the veteran jeweler, whose absence from the banquet was regretted. He was an invited guest, but indisposition kept him to his room.

The menu souvenirs were beautiful specimens of the stationer's art. They were prepared specially by Tiffany & Co., and

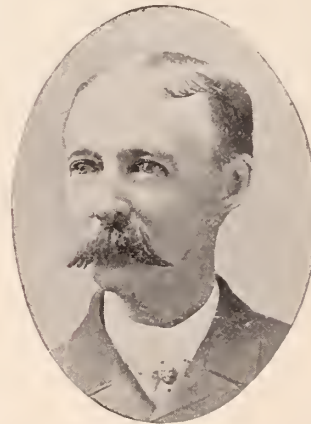

A. K. SLOAN,  
PRESIDENT NEW YORK JEWELERS' ASSOCIATION.

tankards, jardinières, in styles reflective of the exquisite beauties of the periods of the Louis, the Empire and Renaissance. Permeating all were the glorious tints of the rose, the chrysanthemum, the orchid, and the cool green of the fern, the smilax.

Enlivening as was the sight of this display of silver, pottery, and flowers, the soul was even more exalted when the strains of the 'cello, the violin, the oboe, came in dulcet cadences from the balcony above. The occasion did not call for the "Dead March from Saul," or the "Mis-



GEORGE W. SHIEBLER.

the front design represented the coat-of-arms of the association, in gold, laid on a bed of ivy leaves, with the name of the guest and a different device for each, hand painted in water-colors, on the face. The souvenir consisted of five cards, bound with ribbon—the front card being as described, the others showing the menu, the list of invited guests, the toasts, and the officers and banquet committee. The menu was as follows:

About 9 o'clock the president of the New York Jewelers' Association, Augustus K. Sloan, arose and said:

GENTLEMEN:—The time has arrived when it be-

comes my pleasant duty, as we good Masons say, to welcome you once more, and I think that the words of wisdom which we shall hear to-night will be of value to us for the year to come. We are all a band of brothers joined together for mutual protection and benefit, and it is one of the pleasant things in life to witness how each of us strives to see how much money he can put into the pockets of his fellow member. For

**== MENU. ==**

—

HUITRES. GRAVES.

POTAGES.

Consommé Daumout. Bisque d'écrevisses. SHERRY.

HORS D'ŒUVRE.

Brissotins au Suprême.

POISSON.

Filet de Sole à la Royale. Pommes de terre Viénoise. GRAVES.

RELEVÉ.

Selle de Chevreuil, Sauce Oporto.  
Choux de Bruxelles.

CHATEAU LAGRANGE.

ENTREES.

Ailes de poulet finoise.  
Petit pois, Parisiennes.

VEUVE CLICQUOT SEC.

Térapène à la Baltimore.

SORBET DALMATIÉ.

ROTS.

Perdreaux.  
Salade Romaine. MACON VIEUX.

ENTREMETS DE DOUCEUR.

Pêches à la Richelieu.  
Pièces Montées.

Glaces Fantaisies. Fruits. Petit Fours. LIQUEURS.  
Café.

- |                                                                                                                                                                                                                                                                                                                                                        |          |                                                                                                                                                                                                                                                                                                                                 |                                                                                                                                                                                                                                                                                                                                                                  |
|--------------------------------------------------------------------------------------------------------------------------------------------------------------------------------------------------------------------------------------------------------------------------------------------------------------------------------------------------------|----------|---------------------------------------------------------------------------------------------------------------------------------------------------------------------------------------------------------------------------------------------------------------------------------------------------------------------------------|------------------------------------------------------------------------------------------------------------------------------------------------------------------------------------------------------------------------------------------------------------------------------------------------------------------------------------------------------------------|
| <p>John C. Mount</p> <p>James Riley<br/>John R. Greason<br/>A. A. Webster<br/>H. C. Ostrander<br/>Sidney T. White<br/>Chas. Nobs, Jr.<br/>Alexander Lelong<br/>Edward Balbach<br/>Louis Lelong<br/>Isaac Champenois<br/>D. L. Safford<br/>J. P. Slattery<br/>W. N. Walker<br/>A. W. Caney<br/>A. L. Brown<br/>R. A. Robbins</p> <p>O. G. Fessenden</p> | <p>A</p> | <p>Wm. H. Hennege<br/>Chas. H. O'Bryon<br/>Chas. Diesinger<br/>L. S. Lewis<br/>Geo. Scherr<br/>John F. Saunders<br/>Henry E. Ide<br/>J. C. Grogan<br/>J. C. Tilden, Jr.</p> <p>N. C. Downs<br/>G. A. Carter, Jr.<br/>W. H. Wheeler<br/>W. H. Porter<br/>H. H. Butts<br/>F. E. Davis</p>                                         | <p>Geo. W. Shiebler</p> <p>Leon Barre<br/>Richard Horstmann<br/>Frank H. La Pierre<br/>G. A. Henckel<br/>Jos. H. Shafer<br/>Lewis Sunderlin<br/>F. S. Douglas<br/>A. O. Headley<br/>Frank T. Sloan<br/>H. W. Rupp<br/>James S. Franklin<br/>William C. Kendrick<br/>Geo. R. Howe<br/>Geo. B. Jaques<br/>S. B. Sanford<br/>Wm. H. Thurber</p> <p>Aaron Carter</p> |
| <p>Jos. B. Bowden</p> <p>G. M. Hard<br/>R. S. Ferguson<br/>J. T. Perkins<br/>E. M. Parker<br/>M. L. Bowden<br/>B. J. Schmauk<br/>C. Strobel<br/>W. F. Ackerman<br/>John Linherr<br/>John R. Keim<br/>F. B. Morse<br/>L. W. Ballou<br/>F. Keim</p> <p>John S. Spencer<br/>G. S. Noyes</p>                                                               | <p>C</p> | <p>J. H. Johnston<br/>H. P. Doremus<br/>H. T. Ketcham<br/>W. H. Strawn<br/>W. C. Kimball<br/>A. Johnston<br/>E. T. James<br/>W. H. Kaye<br/>Edward J. Spall<br/>W. M. Harker<br/>Geo. E. Stevens<br/>C. B. Churchill<br/>Edward Holbrook<br/>L. D. Cole<br/>Watson A. Miller<br/>R. W. Ryer</p> <p>James E. Spencer.</p>        | <p>Ludwig Nissen</p> <p>Wm. A. Thompson<br/>I. A. Lewis<br/>Emil Knopf<br/>C. F. Pierce<br/>James A. Cheney<br/>Thos. E. Rice<br/>P. L. V. Thiery<br/>S. Jaquette<br/>E. H. Eckfeldt<br/>Wm. H. Loug</p> <p>Harrison B. Smith<br/>Chas. Curie<br/>Francis H. Leggett</p> <p>Alfred H. Smith</p>                                                                  |
| <p>P. T. Tunison</p> <p>A. T. Maynard<br/>W. H. Jones<br/>Bernard Karsch</p> <p>Harry Crawford<br/>Theo. M. Woodland<br/>Chas. W. Wattles<br/>Frederick H. Larter<br/>J. R. Tennant<br/>Chas. G. Braxmar<br/>D. V. P. Cadmus<br/>Robert H. Klitz<br/>Harvey Huestis<br/>S. C. Howard<br/>J. F. Thomas<br/>W. H. Hayden</p>                             | <p>E</p> | <p>William H. Curtis<br/>John W. Reddall<br/>Chas. R. Hansel<br/>John T. White<br/>Herbert W. Richards<br/>John T. Howard<br/>Herbert Cockshaw<br/>S. Cottle<br/>F. Walter Lawrence<br/>Wm. Bryant<br/>Elmer E. Wood<br/>Geo. W. Hutchison<br/>Chas. F. Wood<br/>Horace W. Steere</p> <p>R. Gray, Jr.</p> <p>Geo. N. Wilcox</p> | <p>Geo. Kremenz</p> <p>Robert Leding<br/>John N. Taylor<br/>Frank A. Lebkuecher<br/>Frank Kremenz<br/>F. H. Bawo<br/>David Felter<br/>W. S. Ginnel<br/>Appleton Smith<br/>J. R. Gleason<br/>Stephen Avery<br/>E. V. Clergue<br/>John L. Shepherd<br/>L. J. Mulford</p> <p>William C. Rich<br/>James R. Armiger</p> <p>David C. Townsend</p>                      |

The guests at the main table were:

Mr. David C. Dodd, Jr.	Rev. John W. Brown, D. D.
Mr. Frederic Taylor	Hon. Franklin Bartlett
Judge Noah Davis	Mr. Chas. Stewart Smith
Hon. Chas. A. Schieren	Mr. Louis E. Bomeisler
Hon. Wm. L. Strong	Hon. Julius A. Lebkuecher
Mr. Augustus K. Sloan	Mr. Anthony J. G. Hodenpyl

who took their places shortly after 7 o'clock. Grace was pronounced by Rev. J. W. Brown, D. D. The diners sat as here presented.

# The Genuine Rogers

## Electro Silver Plate

### Spoons, Forks, Knives, &c.

# CAUTION!

The name of **Rogers** is stamped on all sorts of **Electro Silver Plated Flatware**, some of it common and worthless. It is therefore necessary to **carefully examine** the **brand** in order to obtain the **right goods**.

#### THE ORIGINAL AND GENUINE STAR ★ BRAND

which has been made continuously for half a century, given perfect satisfaction and made the name of **Rogers** on Electro Silver Plate celebrated, is stamped

#### ★ ROGERS & BRO. A 1.

If you want the genuine goods which will satisfy your customers, and build up your reputation as a reliable dealer buy those bearing the above trade mark.

For sale by the leading jobbers throughout the country, and manufactured exclusively by

## ROGERS & BROTHER,

16 Cortlandt Street, N. Y. - - - - Waterbury, Conn.

The Oldest Makers of ROGERS GOODS in existence.

THE FLEMISH

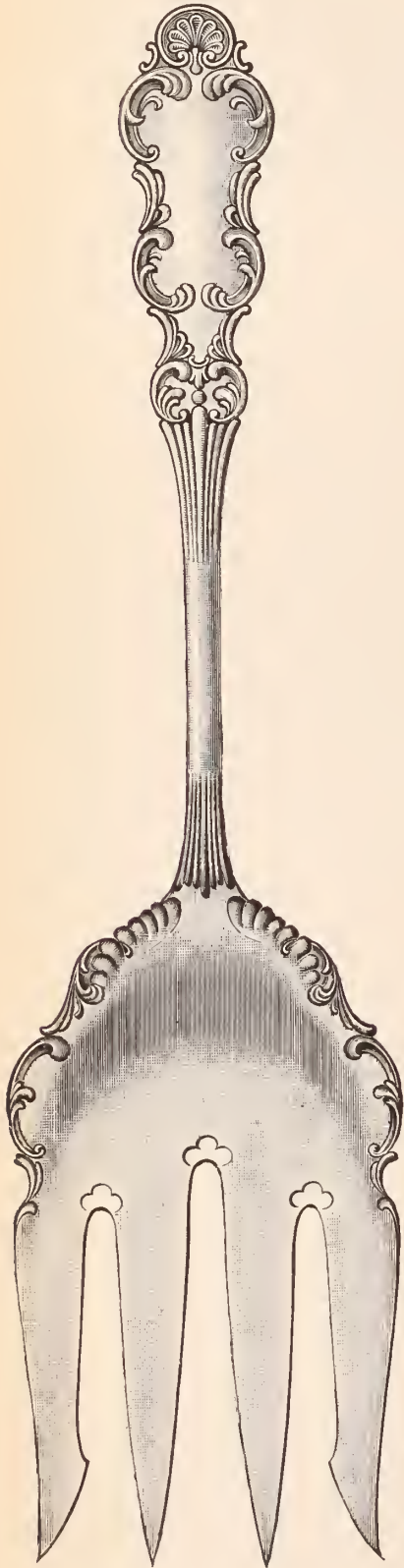

FISHER SALAD FORK.

A Large Line of FANCY PIECES put up in beautiful PLUSH LINED BOXES, suitable for the HOLIDAY TRADE, NOW READY.



JOHN R. KEIM.

the past nineteen years I have been content to sit down there and listen to you and I thank you for the honor you have conferred on me by electing me this year to preside over you and appreciate the fact that I never was in better company in my life than at this present moment. (Applause.) I give you all a hearty welcome. You have enjoyed the dinner but I know you will enjoy the good things in store for you. Our tables never were more beautiful than this evening. Gentlemen, please fill your glasses and rise.

**TOAST:**—*The President of the United States*, which was drunk standing.

**THE PRESIDENT** (continuing).—I want to introduce to you several distinguished gentlemen who have honored us with their presence this evening, who are not on the regular list of speakers, but I know you will be glad to know them and hear from them, if but a word. The first gentleman I have the honor to introduce is well known to you—his name has been a household word for the last two months—the Hon. William L. Strong, Mayor-elect of New York. (Great applause.)

Mr. Strong was received with great applause. He said:

*Mr. President and Gentlemen of the New York Jewelers' Association:*—I guess I've got the appellation right. I have been studying it ever since I sat down. When I received your invitation I made up my mind I would accept. But one of your worthy members came to me and said "The papers say you are no speaker," (laughter) "and we shall expect no speech from you, and I promise not to call upon you." I made up my mind that man would make a first-rate dry goods man. (Laughter.) In my business none of us has made any money for two years, and, on looking at the lusty faces I see here, there is only one business I would like to engage in—the jeweler's business. (Laughter.) I am well satisfied that I will not have any applications for office from any of you gentlemen after January 1st, because you dine like men who would not think a great deal of \$5,000 to \$6,000 a year. (Laughter.) I am delighted to have the honor of appearing here this evening. This is the first public dinner I have attended since November 6th, except one or two private snaps. (Laughter.) I notice you have selected my pastor, who takes care of my spiritual department, to make a speech. Up to this time I have been entirely satisfied with him. (Laughter.) I hope on your next 20th anniversary you will have as lusty a band of gentlemen as I see to-night. I know you don't want me to talk about anything else, as even your gentlemanly member himself told me, I am no speaker, and so I shall yield to gentlemen who will be more interesting. (Applause.)

**THE PRESIDENT**—"Last year we had an election in Brooklyn, but we good old Democrats were not happy, so we turned to and helped elect a man whom in all honor, I take great pleasure in introducing, the Hon. Chas. A. Schieren."

Mr. Schieren spoke as follows:

*Mr. President and Gentlemen of the New York Jewelers' Association:*—This is Mr. Strong's maiden dinner and maiden speech—as Mayor-elect. It he does as well for the next dinner and speech I think he will be fortunate. Once during my canvass I was presented with a hat at a hat factory, and strange to say that hat still fits (laughter), but if the people of Brooklyn are going to keep on, I shall have to visit that factory again. (Laughter.) It gives me great pleasure and I esteem it an honor to respond to your toast. The American jeweler is noted for his good taste and uniqueness. There is no shame about American jewelry—it is like our people, plain and solid. The people at the last election found a jewel and gave him such a brilliant setting that now they expect him to shine with an added lustre, in purity and honesty of purpose. The hard rapping which he may receive in the way of criticism will, I hope, like a good jewel, only add to his lustre. (Applause.) I can truly sympathize in his hard work, but if he is only steadfast to his purpose there will be no doubt of his success. (Applause.)

**THE PRESIDENT**—"Recently there was an election in Newark, N. J., and every one was made happy, as the people selected a man well known for his uprightness. He is a member of our profession and also of the New York Jewelers' Association. It is gratifying to me to introduce the Hon. Julius A. Lebkuecher, Mayor of Newark."

Mr. Lebkuecher said:

I had not been expected to be called upon on this occasion. I have been a member of this association for many years, I have attended a great many annual reunions and I have always looked forward to them with anticipation and great pleasure, but I have always expected to be a listener, and between us that is what I ought to be. I thank you very much for this greeting and trust you will excuse me from further remarks. (Applause.)

**THE PRESIDENT**: "I take great pleasure in introducing Mr. A. J. G. Hodenpyl, President of the New York Jewelers' Board of Trade."

Mr. Hodenpyl spoke at length as follows:

*Gentlemen, Members of the New York Jewelers' Association:* I was highly honored in receiving an invitation to dine with you, and to enjoy your always agreeable company. I immediately wrote as neat and beautiful an answer as I could, which I gave into the hands of a messenger to insure immediate delivery, because I was afraid that the committee feared I would not accept the invitation. (Laughter.) I looked upon the invitation with a great deal of pleasure, for two years ago is the last time that I really enjoyed a square meal. (Laughter.) Last year we gave up our money that the poor out of work might be assisted. I speak of this because every family here represented gave us a helpful hand, and I would not speak of it at all, but that you will remember how that good object was followed by other associations, notably the Chicago Jewelers'

Association, which came nobly to the front. Every effort that we made was successful, and for once the New York Jewelers' Association and the Board of Trade were united in a great and glorious work. The good that you have done, the homes that you have made happy, the joy and comfort that you have brought to many poor souls, the sun shine that you have made to shine in the homes of those poor mothers, and the little children that you have clothed and fed, I need not tell you of, but they are facts known to our Heavenly Father. (Applause.) But let us hope that those dark specks in our history have forever passed away, since Tuesday, Nov. 6, 1894, a day that we shall always remember. (Applause.) As we sit at our firesides we shall tell our children the story of how, under the leadership of Dr. Parkhurst, we turned the rascals out. (Applause.) But what surprised me most of all about this banquet was that last Sunday in the *Tribune* my name was mentioned as one of the speakers and on Monday morning my office was overflowed with reporters and shorthand writers desiring a copy of my speech. Public speaking, however, was never one of my virtues, but some people don't believe it until they see and hear it. (Applause.)

**THE PRESIDENT**—"I am sorry that Mr. Hodenpyl has not had a good square meal in two years, but I am a neighbor of his and will take him out to lunch some day. (laughter). We are very sorry indeed not to have Mr. Tiffany with us, as he fully expected to be until yesterday. A life sized bust model of Mr. Tiffany has been kindly loaned to us for the evening and is now on exhibition in one of the parlors. It is a work of love by the artist, and as the likeness is perfect, he deserves our highest praise (Three cheers for Mr. Tiffany, which were given). Judge Edward T. Bartlett was to have been with us, but a sudden illness in his family prevented him. Our next regular toast is

"OUR FLAG AND OUR COUNTRY."

*'A star for every State, and a State for every Star.'*

"It is with great pleasure I introduce the Hon. Franklin Bartlett."

HON. FRANKLIN BARTLETT'S SPEECH.

*Mr. Chairman and Gentlemen of the New York Jewelers' Association:*—I thank you very much for the honor which you have done me and the toast to which you ask me to respond. It is a difficult thing to ask a Democrat to speak on this occasion and to assign to him a proper toast. I can promise you as a Democrat that we shall remember Nov. 6th (laughter), and can assure you we shall tell our children and our grandchildren of that fatal day. If I am therefore somewhat sombre in my remarks you will pardon me, for our results have not been such as to promote a spirit of mirth, but I shall confine myself to my toast. If it be true that the drum beat of England commences with the rising sun and in the course of 24 hours circles the globe, it is equally true that there is no clime in this



F. H. BAWO.

world in which the stars and stripes do not unfold at the mast-head. Now you will pardon me if in speaking of the flag, I call attention to its history.

The speaker then gave an interesting account of the origin and gradual development of the stars and stripes; then continuing.

There are three things which the flag should teach us, the protection of our citizens wherever they be found on the globe, the extension of our domain within due limits, and the crushing out of all and every sort of anarchy and socialism and populism. (Applause). I don't think that I have any more to say except to thank you for your kind attention and to express my happiness at being here to-night. (Applause). Mr. Quigg, I believe, was to have been here, and I am sorry he is not present. I am glad that this honor has been extended to me by your committee and your President, and can only conclude with the sentiment of the poet:

"The stars have lit thy welkin dome,  
And all thy lines were born in heaven."

(Applause.)

The band played the "Red, White and Blue."

THE PRESIDENT: "Gentlemen, I forgot to mention the fact that Mr. Bartlett was one of our Democratic Congressmen. The next regular toast is

EDUCATION THE BASE OF FUTURE GREATNESS."

*'Education must be universal.'*

"The gentleman who responds to this toast is well known to you all and we have always been more than delighted to hear him speak. I will call upon the Rev. Dr. John W. Brown."

SPEECH OF REV. JOHN W. BROWN, D.D.

Gentlemen, and Members of this Organization: As an allusion has been made to me by my friend and parishioner, Col. Strong, it is fitting that I should say that having brought him so far on his way and with such success as has attended my efforts, there is not much danger in regard to his future. I desire to thank you again for what you have done for me, recognizing me in the same line of age and ancestry as Judge Noah Davis. If we keep on, we will probably both be foster fathers of this organization. But think not that the subject which has been accorded to me is trite because of its familiarity. Education is not only the basis of future greatness but has characterized the greatness of every age in the past, and has marked the development of every country. Men sometimes speak of instruction and education as synonymous, but they are not so. The first means to conjoin, to instill, to inform, while the second means to call out, to develop, to prepare the child for the character which it is to hold in the future, and with which it is to relate itself for weal or woe to the country and the community and the family. (Applause.) The environment is not created by the character but is

creative of the character. Pardon me if I speak earnestly, because every one of us must be identified with this true sense of education. We need to teach our children so that they shall become noble citizens, and to do this we must give our attention to two divisions of education, that of the physical man as well as that of the intellectual and moral. No matter how grand may be the intellect that impresses itself upon humanity, unless its humanity is supported by the principles of divine love, it is not educated. (Great applause.)

THE PRESIDENT—"Our next regular toast is

'THE GLADSOME LIGHT OF JURISPRUDENCE.'

*'Just laws are no restraint upon the freedom of the good, for the good man desires nothing which a just law will interfere with.'*

"It is hardly necessary to introduce a gentleman who has been one of us for the last nineteen years—our godfather, Judge Noah Davis."

SPEECH OF HON. NOAH DAVIS.

It is just my luck to be called upon after such a speech as the Rev. Dr. Brown's. If I could equal the eloquence of that speech and the sublimity of its sentiments, I should consider myself happy indeed, but I must give you what you would expect from an old godfather of 76. We have a splendid horse show in town, with the most speedy animals of their kind, and yet with all their speed in running we could match them to-night with our two Mayors (Laughter.) But I was a little astonished at Col. Strong's speech. I thought we had chosen him to smash the ring, and yet he proposes to join the ring-makers. (Laughter.) I enter my solemn protest against his joining any other class of ring-makers, and I hope that in our great city we shall have such a change that there will be no more need for rings—a change which will make us proud of it. This has been to me an evening of surprises, not the least of which is to see how rapidly you are growing young. Twenty years ago I saw, it seems to me, an older body of men than I see now. Where have they gone—that grand old hero, Gen. Sherman and the rest? I want to say to Brother Bartlett—we are brothers in LAW now—that he omitted to speak of one of the most beautiful incidents connected with the history of the flag. It is said that two ladies of Saratoga made the first flag out of two garments of red, white and blue—and how the boys did fight under that flag! (Laughter and applause.)

THE PRESIDENT—"The next regular toast is

'COMMERCIAL INTEGRITY—THE SECRET OF SUCCESS.'

*'Whatever anyone does or says, I must be good, just as if the Emerald were always saying this: Whatever anyone does or says, I must be Emerald and keep my color.'*

"I have the honor to introduce to you the gentleman who, when president of the Chamber of Commerce, has done so much for our beloved city, Mr. Charles Stewart Smith."

CHARLES STEWART SMITH'S SPEECH.

Mr. President and Gentlemen:—I thank you for the gravity of the sentiment given me, but I can best illustrate it by referring to Colonel Strong and Mr. Schieren, who have illustrated it in their lives. I am glad that you have given me as an inspiration a quotation from the grandest of all philosophers. There is no occupation more instructive than to contemplate the lives of men of the past, and the profession to which your association belongs is one of the oldest and most interesting. The workers in silver and gold have been, perhaps, more closely connected with the art progress of the world than any other profession. Two or three thousand years before the Christian era men of your profession wrought wonderful things in silver and gold—things which have been models for our artists five thousand years later. There has always been an intimate connection between commercial success and the cultivation of art. The country most advanced in fine arts is also most advanced in useful arts. Commerce is older than any patent of nobility, older than written history, and the merchant has been the patron and founder of the library, the school and the hospital.

In the last analysis character is the final test of all human conduct and marks success or failure in the life of any man or institution. A bill of exchange is but a certificate of character of its signers. Why did we have a change in our Government last election? Because Tammany, which belongs to no party except the party of plunder, was bankrupt of character. (Applause.)

THE PRESIDENT:—"Our next regular toast is

'WOMAN'

*'Loveliest of women, heaven is in thy soul,  
Beauty and virtue shine forever round thee,  
Brightening each other, thou art all divine.'*

"I take great pleasure in introducing Mr. Louis E. Bomeisler."

LOUIS E. BOMEISLER'S DISCOURSE.

We have partaken of a feast worthy of Lucullus, every sense is laden with delight; let us now with deep reverence honor the women of our hearts. Those twin sisters, New York and Brooklyn, have been heroically wooed and finally won to righteousness by those Siamese twins of virtue and those latter-day saints of municipal regeneration, Strong and Schieren. It has been common custom to mark the marriage ceremony by an exchange of rings; this is one instance where that ceremony was marked by the demolition of rings. (Laughter.) In the language of the curb, "rings are not in it." It is appropriate that we should dwell for one moment on the first lady of the land. I refer to the wife of Adam. (Laughter.) Eve was a woman of rare taste; she loved the seductive apple not wisely but too well; she was a "fruitful" woman. I regard this as the time and place to forever





GEO. W. STREET.

cast the mantle of charity over the shoulders of our erring ancestress and to pardon the only disgrace of her life in springing from the rib of such a man as Adam, who sought to shield himself at the cost of woman's heritage. I make free to say that had any one of you been in the garden, he would have plucked the fruit, saved the lady, and taken the consequences. (Laughter.) Woman has ever been the motive power of the world. Columbus would never have discovered America had it not been for Isabella and her jewels. That points a moral—that every woman should have a full line of jewelry. (Laughter.) The future of our Republic rests in the very lap of woman; the hearthstone is the cornerstone of the State; the cradle of the Republic is rocked by woman's hands. (Applause.)

THE PRESIDENT—"Our next regular toast is

'OUR FRIENDS'

*'See our guests approach;  
Address yourself to entertain them sprightly,  
And let's be red with mirth.'*

"It is with great pleasure that I introduce for the second time to you Mr. Frederic Taylor."

SPEECH OF FREDERIC TAYLOR.

Mr. Taylor who was received with great applause spoke as follows:

*Gentlemen:* I feel that I ought to make an apology for rising to say anything at so late an hour, and you will always, I am sure, be grateful to me that I refrain from making the speech I had intended and I hope you will accept my security for the fact that I intended to make a rattling good speech, lifting my glass and asking the guests who are here assembled to unite with me in drinking wealth, health, and happiness to the members of the Jewelers' Association. I might say just one word of warning to you jewelers with reference to future guests. Whenever you make a spread of this kind and don't want any of us guests to come bothering you, don't ask us, for if you do ask us you will find yourselves in a hole and will realize more than ever before the truth of that so popular song, "You can't lose me, Charley." (Laughter.) Next year I will be glad to make a speech, but at this late hour you will excuse me. (Mr. Taylor sat down amid cries of "no, no, we've been waiting for you," and great applause. Then continuing, he said—) What I had in mind to say if I had managed to get on the floor two or three hours earlier, was that when I received the invitation I thought that as I was permitted last year to enjoy your so delightful hospitality, I was asked this year merely out of compliment. ("Nothing of the sort"). I thought I should decline the invitation, but when I recollected last year's jamboree and the awfully good dinner, when I remembered all the genial jewelry gentlemen whom it was my pleasure to meet, and their exceeding courtesy to me, which, as some of you will remember, was the presentation of a whole large cold bottle all for my own use, when it was my misfortune to be seated between two such absorbent parties as young Tiffany and old Dodd, (Great laughter.)

I wanted so much to come that I didn't have the moral courage to say no. Of course you have all heard of that man who was invited to join in a midday snifter, but refused. They indignantly asked him if he had any reason for going back in that unfriendly way on a good ball, and he said he had two reasons. The first, 'When my poor old mother lay on her death bed, she said, "my boy I know your weakness; if you would promise never again to touch the nasty stuff I would die happy," and I promised.' 'But you said you had another reason.' 'Yes,' he replied, 'the other reason is this—I've just had a drink and don't want another.' (Great laughter.) As I made a speech at last meeting I feel that I don't want to make another so soon after. But I came here expecting to see you jewelers depressed about the difficulties that had come upon your 14th St valuable customer. I spoke to Mr. Dodd about it, and he told me that while you don't expect a large demand in watches and diamonds, you do expect a large demand in chains and bracelets. (Great laughter.) When we were last here we were rejoicing in the



JOSEPH B. BOWDEN,  
PRESIDENT, 1893.

manifestation of the people's power in the election of Judge Bartlett. Mr. Dodd tells me that since the last dinner Judge Bartlett has taken upon himself a wife, and the thought occurs to me that if the distinguished Counsellor of the Jewelers' Association did the square thing in the jewelry line by the lovely bride, if he furnished her with jewelry gew-gaws to a reasonable extent—it occurs to me that you jewelry gentlemen would get back from that poor judge in one fell swoop all the fees that he ever charged you for legal service. (Uproarious laughter.) To-night we are rejoicing in the still further manifestation of the people's power. It has demonstrated one thing to

everybody's satisfaction, and that is the truth of that old song which begins—

"Man wants but little here below,  
But wants that little *Strong*."

(Laughter.) Not only that, but New York men want it for longer by one year than any other Mayor yet has served. The fight to elect him has not been upon a party platform, but upon the ten commandments—of order against disorder, of virtue against vice; of the church, the schoolhouse and the home against the brothel and the dive—and because of the great triumph that we achieved the sunlight has been brighter, the laughter of our children has been more musical, and the inside of all our homes has been happier. (Applause.) My toast says something about being "sprightly and red with mirth." When you provide a lay-out like this you need never worry about doing the sprightly business under the leadership of such high rollers as Judge Davis. (Laughter.) You need not bother yourselves about "red" either. We will paint everything within reach vermilion, and we won't paint it with "mirth" either. (Laughter and applause.)

THE PRESIDENT—"Our next toast is

'OUR CRAFTSMEN—ARTISTS EVERY ONE.'

*'And the smith his iron measure, hammered to the anvil chime,  
Thanking God, whose boundless wisdom makes the flames of poetry bloom  
In the forge's dust and cinders, in the tissues of the loom.'*

"I have great pleasure in introducing Mr. David C. Dodd."

DAVID C. DODD'S ADDRESS.

*Mr. Chairman and Gentlemen:* I want to thank you for the kind invitation to be present on this your 20th annual dinner. My mind has taken in the early part of the evening something of a reminiscent turn as I have contemplated the rapid lapse of time. I remember well the meeting of the committee which drafted your constitution, I could recall most of their names, and I remember the common sentiment which actuated all, to bring together into fraternal community the members of the jewelers' trade. Some of them have gone; it is unnecessary that I should recall their names, but those who have attended these gatherings for the last 20 years can testify that the organization has been fruitful in results, has accomplished much in cementing the bond of brotherhood which should bind all trades. I am not going to talk of politics to-night, nor very much of the sentiment which you have assigned me. Politics is a dead issue, but I can hardly refrain from a word of congratulation, for I know the deep feeling which actuated the pure and noble men of your city when they viewed the inroads which were being made upon its integrity and honor. The consciousness entered the minds and hearts of the people that something must be done, and shoulder to shoulder they have given the assurance that New York city is indeed redeemed. (Applause.) It has been said that upon great occasions men have risen to grand results. It was a Presbyterian dominion on Madison Ave. (Great applause) who, bearding the

tiger in his den, at the risk of his reputation and his standing, challenged these men and led a fight of which I am certain not only the citizens of New York but every American citizen must be proud. We must admire that moral courage which, taking reputation, everything in hand, ventures in the fight with the determination that right shall triumph, and the name of Chas. H. Parkhurst stands to-day as one of the highest evidences of true moral courage which the world has ever furnished. (Applause.)

Now I did not mean to say that exactly. Let me see—what was I to talk about. Oh, yes, "Our Craftsmen—Artists All." Well, we ought to be artists, we some of us strive to be, and while I have listened with great pleasure to the gentlemen here to-night, they know but little of the environment with which the jewelry art has to contend. What wonderful advances have been made in forty years! And to-day American jewelry stands among the very first in workmanship, style and finish. (Applause.) But I sometimes think that our jewelers have not begun to keep pace with the silversmith. It is true that they have a wider range for the display of artistic taste, and there is scarcely a royal family in Europe that does not contain a large representation of American-made silverware. (Applause.) I want to say to the young manufacturers here to give the very highest ideal possible, not only in regard to the art as applied to your business, but also as to the character which you shall exhibit in the transaction. Michael Angelo's Moses has been the adoration of every visitor to the Eternal City, and will continue to be one of the greatest examples of art that the world has ever furnished. You may not be able to accomplish this, but you may produce some form of beauty that shall at least gratify the taste. Make this your ideal and ever remember the sentiment to which I am called upon to respond, "Our Craftsmen—Artists all." [Applause.]

THE PRESIDENT:—"I want to thank you all for the close attention you have paid to the speakers, and now the band will play 'Home, Sweet Home.'"

### Coroner's Jury Decide That Jeweler Goldstein Maintained a Death Trap.

UTICA, N. Y., Nov. 17.—The fourth and final hearing into the inquest into the death of Stuart A. England was held at the court house Monday night by Coroner Tefft. F. H. Pellham, of the General Electric Co., the only witness called, gave expert testimony at great length.

The jury brought in a verdict that Stuart A. England came to his death at 5.30 P. M., Oct. 25, in the jewelry store of Bernard Goldstein, 60 South St., from an electric shock received by coming in contact with the safe. The jury finds that Goldstein had tapped the wires of the Equitable Gas and Electric Light Co. and conveyed the current to his safe; that he had often asked frequenters of the store to test the force of the electricity and had led them to believe it came from a battery in the cellar; that Goldstein had made some study of electricity and its appliances, and the adroit manner in which he conveyed the current to his safe bears witness to his skill, and in connection with the cautious manner of the tests made by frequenters of the store leads to the belief he had some idea of the danger.

The jury finds that the current was controlled by a switch by which electrical connection with the safe could be easily made or broken, and that the safe was charged with electricity during the entire afternoon, England was killed; and while there is no malice shown, yet there is no excuse for

Goldstein maintaining a death trap in so public a place as his store, ready charged for the first person who happened to come into contact with it.

### Six Robbers Slug a Night Watchman and Crack Several Safes.

ASHLEY, Ill., Nov. 16.—This city was raided by six robbers about 2.30 o'clock Saturday morning. The night watchman, Harvey Woodrome, was knocked down from behind and told if he attempted to give the alarm they would cut off his head. He was bound and gagged and thrown through the window into the Opera House, where he was found about 6 o'clock. The robbers forced an entrance to the Post Office, drilled the safe, filled it with dynamite and completely destroyed it. Then they entered a grocery store and next the jewelry store of D. A. Carson and blew off the fire-proof door to his safe, but failed to get in the vault, which contained \$3,000 in money and jewelry.

The explosion awoke parties living near by, who gave the alarm. It was thought the intention was to blow all the safes in town. Several dwellings were entered, but nothing of value secured. There is a large reward offered.

Burglars at Virginia, Ill., entered C. F. Naecker's jewelry store, Nov. 9th, blew open the safe, and stole a quantity of goods. Loss not stated.

**ROY**  
TRADE MARK.

# WATCH CASE COMPANY.

MAKERS OF Fine Gold Watch Cases.

TO THE TRADE...



WHEN YOU SELECT YOUR HOLIDAY STOCK of Gold Watch Cases remember that you make no mistake by asking for

**ROY**  
CASES.

**ABOVE TRADE MARK**

in every Case, and you can depend on Quality of Gold as well as of workmanship.

**THROUGH JOBBING TRADE ONLY.**

REMEMBER that we have reduced our Photo Miniatures to \$2.00 each, and make nothing but first-class work.

# The Jewelers' Circular

AND  
HOROLOGICAL REVIEW.

PUBLISHED EVERY WEDNESDAY BY

THE JEWELERS' CIRCULAR PUB'G CO.,

189 BROADWAY, NEW YORK CITY.

A JOURNAL DEVOTED TO THE INTERESTS OF JEWELERS, WATCHMAKERS, SILVERSMITHS, ELECTRO-PLATE MANUFACTURERS, AND ALL ENGAGED IN KINDRED BRANCHES OF INDUSTRY.

Our Editorial columns will contain our own opinions only, and we shall present in other columns only what we consider of interest or value to our readers. Advertising matter will not be printed as news.

Advertising rates in THE CIRCULAR are lower, considering the number of tradesmen reached by its large circulation, than in any other jewelry journal.

Notices of changes in standing advertisements must be received one week in advance; new matter can be received up to Monday.

## INFORMATION FOR SUBSCRIBERS.

### Terms of Subscription, Postage Prepaid.

	PER ANNUM
United States and Canada, . . . . .	\$2.00
Foreign Countries in Postal Union, . . . . .	4.00
Single Copies, . . . . .	.10

New subscribers can commence at any time.

Payments for THE CIRCULAR, when sent by mail, should be made in a Post-Office Money Order, Bank Check or Draft, or an Express Money Order or Registered Letter. All postmasters are required to register letters whenever requested to do so.

Pay money only to authorized collectors having proper credentials.

Returning your paper will not enable us to discontinue it, as we cannot find your name on our books unless your address is given.

In changing address always give the old as well as new one. Your name cannot be found on our books unless this is done.

We will continue to send papers until there is a specific order to stop, in connection with which all arrearages must be paid; but such an order can be given at any time, to take effect at the expiration of the subscription. All such orders will be promptly acknowledged by mail.

The Courts have decided that all subscribers to journals are responsible until arrearages are paid in full; and an order to discontinue has been received by the publisher.

Member of the American Trade Press Association

Vol. XXIX. Nov 21, 1894 No. 17.

**The Jeweler**  
as a  
**Happy Man.**

**G**AZING over the aggregation of diners at the 20th annual banquet of the New York Jewelers' Association, the observer must have remarked characteristics that cause the jewelers to occupy a unique position in the industrial world. The jewelry industry is an industry of gentlemen. In the mind of the simplest and least successful jeweler resides an intellectual appreciation of art and a knowledge of one of the oldest, most universal and most lovely of handicrafts, which consciously or unconsciously, often lift his aspirations beyond material gain. Handling constantly the most precious of metals and gems, the quintessence of riches, the jeweler is seldom a rich man; but, if we can judge by externals, he is a fruition of Seneca's teachings—a happy man. Jewelry being essentially an expression of love and beauty, the artificer or dealer, always in contact with others' happiness, must come

at length to reflect some of the joy himself. The bridegroom, the friend, the doting father, the adoring wife, the lover, these are his customers, all happy at the moment of purchase. The jewelry store is Love's Mecca.

**"Not Responsible For Goods Left After 30 Days."**  
**T**HE following query sent to a daily newspaper brings up for consideration a subject that is of great interest to all jewelers who embody in their business the principle referred to:

What remedy, if any, have I in the following case: I left my watch and chain for repairs with a responsible jeweler; I was handed a card (as receipt) for the same, which bore at its head in prominent type, "Not responsible for goods left after thirty days." Through some oversight I did not make demand for my property until very nearly six months after the watch and chain were left with the jeweler. I am now told by the latter that he personally remembers this watch and chain were awaiting my pleasure for fully sixty days after it was left with him and though he had it amongst his regular finished job work, he cannot now find it or any trace of it, and sets up the plea that his responsibility ceased after thirty days.

It would be well for all jewelers to know that the answer of their brother craftsman is not sufficient. The notice printed at the head of his receipt releases him from the strict liability which would otherwise be imposed upon him, but it does not release him from all liability. It does not excuse him if the loss is the result of fraud upon his part or of his gross or willful negligence. Whatever the character of a bailment may be, the bailee is always bound to redeliver upon request, the thing bailed, after the purpose of the bailment is satisfied. If he would justify a refusal to return the property he must show affirmatively that he has exercised such care as his contract called for, and that the loss occurred in spite of such care. The demand and refusal make out a *prima facie* case of negligence against the bailee, unless he can give a valid excuse for not delivering the property. The correspondent has simply to sue for the value of his watch, when it will become the duty of the jeweler to show how it was lost, and that it was through no fault of his.

**A** CHICAGO so-called jeweler endeavored to levy a variety of blackmail upon involuntary customers by dueling them with postal cards. We are gratified to learn the jeweler came to grief, for his method of conducting business should be rooted out.

**W**E have had occasion before to remark upon the present almost universal tendency among jewelers to enter new fields in search of ideas to embody in their productions. Among the latest evolutions in jewelry designing are the scarabæus and the "horsey" jewelry and trinkets, described at length in this issue, the former being a development and extension of previous isolated patterns, and the latter a manifestation of contemporaneous social interests.

**N**OW that the Legislative sessions are soon to open jewelers of the various States should make preparations for concerted action in an endeavor to have a uniform measure passed in relation to the stamping of silverware. We are pleased to note that R. J. F. Roehm & Son, Detroit, Mich., are circulating a petition among their fellow tradesmen asking them to endorse the bill drafted by THE CIRCULAR and forwarded them recently.

**T**HAT part of Broadway, New York, extending from 14th to 34th Sts. represents industry on its highest plane. Here merchants handling the finest of industrial products find location, and set the pace for merchants of the principal thoroughfares of sister cities. Their methods of business are keenly and constantly investigated, and therefore the opinions expressed in favor of and against the marking of prices of jewelry in the show window, a practice that has obtained to some degree of late among the dealers in the American Rue de la Paix, will be read with interest by all jewelers. These will be found under the department Matters in Jewelry Storekeeping, in this issue of THE CIRCULAR.

### Benjamin Markson Closed by the Sheriff.

ELMIRA, N. Y., Nov. 19.—Benjamin Markson, 111 W. Water St., this city, was closed the past week by the sheriff on two chattel mortgages amounting to \$3,843. He carried a line of jewelry in stock with his clothing business, and numbers among his creditors several jewelers, namely: M. G. Levy, \$150; Roseman & Levy, \$50; M. Freudenheim & Bro., \$300; Freudenheim Bros. & Landy, \$35; L. Freudenheim & Bro., \$50. The stock of goods and fixtures are advertised for sale.

### Suit Over Use of the Word "Rogers" in Stamping Silver Plate.

HARTFORD, Conn., Nov. 19.—The Wm. Rogers Mfg. Co., of Hartford, through their attorneys, Chamberlain & Mills, and Alling, Webb & Moorehouse, the latter of this city, have commenced suit against R. Wallace & Sons Mfg Co., of Wallingford, demanding \$25,000 damages and asking for an injunction restraining them from using the stamp of "Wm. A. Rogers" and any stamp embracing the word "Rogers" in connection with silver plated table ware.

Judge Prentice, of the Superior Court, granted a temporary injunction which was served upon Henry J. Wallace, secretary of R. Wallace & Sons Mfg. Co., Saturday.

It was reported in the last issue of THE CIRCULAR that the Manhattan Silver Plate Co., Lyons, N. Y., had bought the plant and stock of the Acme Silver Plating Co., Toronto, Can., for \$16,000. This the Manhattan Co. say was erroneous, as they have not made the purchase, neither do they intend doing so.

### New York Notes.

Max Freund & Co. have entered a judgment for \$706.07 against Isaac Boltansky.

Among the departures for Europe last was R. Fenner Smith on the *Campania*.

A judgment for \$126.15 has been entered against Nathan Frank by Frederick Kaffe-man.

A. Schoen, 17 Alabama Ave., Brooklyn, has given a chattel mortgage on safe to D. Greenberg for \$75.

Duryea Jewelry Co., 180 and 212 Broadway, last week gave a bill of sale of jewelry fixtures to L. W. Pierce & Co., Providence, R. I., for \$1,200.

Thomas H. Seaman, a retail jeweler of Brooklyn, has removed his establishment from 679 Myrtle Ave. to the more central location at 341 Fulton St. Mr. Seaman was located for 25 years at his old store.

The General Term of the City Court, Wednesday, decided the appeal of Adolph Raduziner from the judgment of \$383.38, entered against him June 27th last by A. J. Pearl. The judgment was affirmed with costs.

The handsome "Chrysanthemum" vase, one of the finest pieces ever made in the shop of Ludwig, Redlich & Co., occupied a post of honor in one of the Broadway windows of the Gorham Mfg. Co., all last week. It attracted much attention.

Jno. L. Shepherd, the New York agent of the Keystone Watch Case Co., now has the honor of prefixing the title "Col." to his name. Mr. Shepherd was last week appointed aide-de-camp, with the rank of Colonel, to Commander-in-Chief Lawler, of the G. A. R.

George Karmel, dealer in fancy goods and jewelry, 281 Grand St., made an assignment Monday to Julius E. Mosheim, giving preferences to Abraham Beigenman, the Union Square Bank, Langfield Bros. & Co., and E. Wertheimer & Co. He had a department in Lichtenstein's Grand St. store. Liabilities about \$6,000.

Albert Lorsch & Co., 37 Maiden Lane, New York, and Providence, R. I., will on Jan. 1st give up their jewelry line and devote themselves wholly to their precious stone business, the latter having increased until it now requires their undivided attention. The firm will, therefore, immediately begin to close out their entire stock of jewelry.

In the Supreme Court, Brooklyn, Thursday, Francis Deacon, a manufacturing jeweler at 12 Maiden Lane, obtained a judgment against Callon H. Betts, a lawyer, for \$881.90. The action was brought on two notes given by Betts in payment for jewelry sold him. Betts gave a check on the First National Bank of Poughkeepsie, but it went to protest.

The trial of the actions against Chas. Seale, brought by the Gorham Mfg. Co., W. B. Durand and Max Freund & Co., commenced Monday before Judge Beach in

Special Term, Part I, of the Supreme Court. The suits which will probably extend over two or three days are brought to set aside Seale's assignment on the charge of fraudulent disposition of property and other allegations of fraud. An account of the trials and their outcome will be published next week.

The General Term of the Supreme Court Friday handed down its decision on the appeal of the case of Lippman Tannenbaum against Gyulo Armeny argued before it Aug. 8th. The action was brought by Tannenbaum to obtain an accounting between himself and Armeny in an alleged co-partnership in the Azure Mine. The Court below decided that the mine was partnership property of Armeny and Tannenbaum and ordered an accounting. The General Term has now affirmed its decision with costs.

Franklin Bien, on behalf of the Kimberley Diamond Co., formerly of 861 Broadway, obtained from Judge Truax in the Supreme Court, Friday, an order to show cause for the appointment of a receiver on proceedings for a voluntary dissolution of the company. The partners allege that there are no liabilities and no assets. The hearing was set down for Dec. 3. The company was incorporated on April 16, with a capital stock of \$25,000 to take up the business previously carried on by Benjamin S. Wise, who failed in March last and he became manager. The promoters named in the incorporation papers were Max Goldsmith, 315 E. 30th St., Hyman Hein, 209 Green St., and Harry Arnold, 12 Front St., New York. As previously stated in THE CIRCULAR, the company discontinued business about six weeks ago.

### Providence.

J. T. Fletcher has removed his retail store to 1854 Westminster St., where he has fitted up very fine quarters.

John T. Quayle has been appointed custodian of the estate of the late Thomas Quayle; bond \$50,000.

Hon. Hiram Howard will celebrate the 60th anniversary of his birth on the 26th inst. He is still hale and hearty and would hardly be taken for that age.

The first of a series of Winter socials was held last Monday evening by the members of the Kent & Stanley Social Club. About 150 people enjoyed the occasion.

A fire on the third floor of the Ostby & Barton Co.'s building was discovered at an early hour one morning last week, and before it was extinguished did damage to the extent of several hundreds of dollars.

George C. McCormick & Co. have been incorporated as the McCormick Co. with Dean Southworth as president, Walter S. Gardiner as secretary and George C. McCormick as treasurer. The capital stock is named at \$50,000.

### Last Week's Arrivals.

**THE CIRCULAR has perfected arrangements for obtaining the names and hotel addresses of all the latest buyers visiting New York, and each day posts in its office, 189 Broadway, a bulletin which every member of the trade is cordially invited to copy.**

The following out-of-town dealers were registered in New York during the past week: C. G. Fogg, Shephard & Co., Providence, R. I., Union Square H.; H. E. Kirstein, Rochester, N. Y., Imperial H.; L. R. Rosenstock, Petersburg, Va., 350 Broadway; F. M. Todd, New Haven, Conn., 118 North St.; J. K. Wright, Indianapolis, Ind., Broadway Central H.; W. V. Page, Boston, Mass., Grand Union H.; T. C. Tanke, Buffalo, N. Y., Imperial H.; J. W. F. Podmore, Troy, N. Y., Astor H.; J. T. Slattery, Manchester, N. H., Grand Union H.; F. E. Davis, Northampton, Mass., Murray Hill H.; C. W. Bixler, Easton, Pa., Coleman H.; W. C. Kendrick, Louisville, Ky., Bartholdi H.; A. D. Norton, Gloversville, N. Y., Park Ave. H.; H. A. Allan, Montreal, Que., Holland H.; M. Milhiser, Richmond, Va., Marlborough H.; H. A. Heath, Newport, R. I., Everett H.; L. Sunderlin, Rochester, Gilsey H.; F. A. Robbins, Pittsfield, Mass., Sturtevant H.; F. A. Hubbard, Springfield, Mass., Sturtevant H.; J. B. Mayer, Buffalo, N. Y., Plaza H.; J. C. Grogan, Pittsburgh, Pa.; St. James H.; F. B. Nourse, Cortlandt, N. Y., Union Square H.; C. W. Wattles, Pittsburgh, Pa., Westminster H.; R. Leding, Washington, D. C., St. Denis H.; J. P. Fleming, Pittsburgh, Pa., Astor H.; I. G. Dillon, Wheeling, W. Va., St. Denis H.; R. H. Galbreath, Cincinnati, O., Imperial H.; G. H. Ford, New Haven, Conn., Gerlach H.; W. H. Thurber, Providence, R. I., Murray Hill H.

W. D. Susten, Monroe, La., has sold out.

H. G. Booth, Rochester, N. Y., is selling out at auction.

William Koeppel, Kearney, Neb., has sold out for \$600.

Mr. Garsel has opened a new store in Fairmont, Minn.

A. Hazy, Lexington, Ky., has been attached for \$1,300.

Charles F. Dufue, Chillicothe, O., has sold realty for \$12,000.

John E. Bull has started a jewelry and fine stationery store in Billerica, Mass.

Clarence Gleason, Lyons, Wis., went to Butte Mon., last week where he will engage in the jewelry business.

Frank Williams, a noted Chicago crook, is under arrest in Buchanan, Mich. He will be taken back to Ohio, he having escaped from the Columbus Penitentiary, where he was serving a sentence for diamond robbing.

L. TANNENBAUM & Co.,

IMPORTERS AND CUTTERS OF

**Diamonds and Precious Stones,**

Cor. Maiden Lane & Nassau St.,

NEW YORK.

25 Hatton Garden, London.

TELEPHONE, LONG DISTANCE, 1959 CORTLANDT.

## Special Announcement.

Mr. L. Tannenbaum begs to notify his customers and the trade in general, that he has largely extended his facilities for cutting and polishing. Hereafter he will cut and polish not only RUBIES and SAPPHIRES, which has been done for the past 15 years with increasing and gratifying success, but

# DIAMONDS

and all other stones which undergo this process.

Modern machinery of the best and most approved pattern, and workmen of the highest class will enable Mr. Tannenbaum to offer, direct from the cutter's hands, that excellent workmanship demanded by American buyers, at

## PRICES THAT DEFY COMPETITION.

Nor will buyers of Diamonds be the only people benefited. Mr. Tannenbaum imported a five years' supply of rough Rubies and Sapphires DUTY FREE under the old tariff. These goods are now being cut and polished and it is very evident that in these particular stones he can make UNAPPROACHABLE PRICES.

New York as the future Diamond Market is not a phantasy. American cutters will be shown an assortment of rough, at prices which will perhaps cause them to believe that this has already been brought about. All arrangements have been made by the firm for enormous shipments of DIAMONDS, EMERALDS, PEARLS, SPINELS, CATSEYES, MELLEES and all kinds of Precious Stones, although to-day the assortment offered by L. Tannenbaum & Co. ranks second to none in this country.

 HIGHEST PRICE PAID for all AMERICAN PEARLS and OTHER PRECIOUS STONES.

# A MODEL FACTORY BUILDING.

THE KENT & STANLEY CO.'S MAMMOTH NEW STRUCTURE, THE FINEST OF ITS KIND IN THE WORLD.

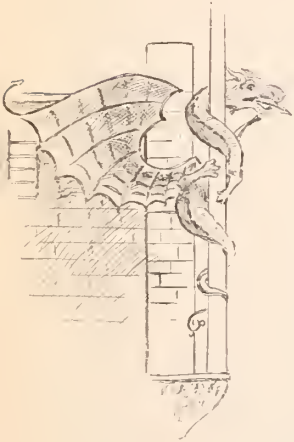

PROMINENT among the many handsome factory buildings for which Providence is noted is the handsome structure built and occupied by the Kent & Stanley Co., on the Square bounded by Sabin, Aborn, Beverly and Mason Sts., in that city. The property which it occupies was the location of the old-time popular skating rink, destroyed by fire last year. Mr. Edwin F. Kent, recognizing the advantages of the site, on his own responsibility purchased the property after the fire, though at that time the building occupied by the Kent & Stanley Co., at Eddy and Fountain Sts., was generally looked upon as a model factory, excellently planned and perfectly equipped.

Mr. Kent's foresight in the matter of the purchase of the new site was soon endorsed by his partners. Its proximity to the new railroad depot, which will be one of, if indeed not the finest, in the country is a guarantee of increasing values in that section of the city, while the increased shop room was something rendered imperative by the firm's constantly increasing business.

Work on the new structure which is depicted in one of the illustrations in this article, was begun on November 1, 1893, and October 1, 1894, the company was operating in its new quarters.

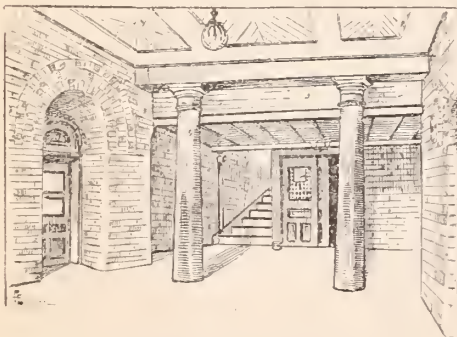

MAIN ENTRANCE ON SABIN ST.

The readers of the CIRCULAR can gather an idea of the immensity of the structure when it is borne in mind that it occupies an

acre of ground, rises seven stories above the foundation, has over 250,000 square feet of floor space, about 1,200 windows and required over five million bricks in its construction. While nearly all available space has already been leased, firms seeking modern quarters will do well to bear in mind that rentals are figured on a basis of 30 cents per square foot per annum, including power, steam heat water and elevator service.

The ground plan and character of the plot is excellently suited for the purpose to which it has been put. The L shaped formation gives it a frontage of 276 feet on Mason St., 221 feet on Aborn St., 106 feet on Sabin St., and 123 feet on Beverly St. A light well 40x200 feet extends from roof to basement in the main structure



THE KENT & STANLEY CO.'S BUILDING.

which with the additional advantage of four street frontages makes that great desideratum, good light, an assured fact for each tenant.

Red brick with brownstone trimmings was the material used for the walls, which rest on particularly solid foundations. At either corner on the Sabin St. facade are two handsome flag staffs held in place by artistic creations in wrought iron of dragons, one of which is incorporated in the initial letter beginning this article. Flags floating from these staffs bear, one, the company's trade mark on a white field and the other the national colors.

The two entrances to the building are well worthy of attention. Each shows a granite arch, while within enameled bricks of a light bluff tint please the eye and present an imperishable surface.

## THE KENT & STANLEY CO.

Our illustration shows the Sabin St. entrance with the handsome wrought iron elevator in the back ground, and two beautifully silvered supporting columns. The other entrance on Beverly St. is practically the same. Marble slabs for the names of the tenants is another feature not usually found in a factory building, and rapid running passenger elevators at either entrance afford quick access to, or egress from any floor. In the driveway running through from Sabin to Mason Sts., are two commodious freight elevators.

Floorings throughout are of maple, each floor being nearly an acre in area. The supporting columns are of iron, rising thirteen feet to the ceilings. Grinnell sprinklers and all other modern factory conveniences make the building a perfect one, whether from the view of the tenant, the insurance or the factory inspectors. Over 3,500 hands can find accommodation within its walls. Power and light are furnished by the company's private electric plant, one of the finest in the country.

The offices of the Kent & Stanley Co. are fitted up in oak, in the best taste, and pre-

sent an exceedingly attractive and handsome appearance. They occupy practically the whole of the Sabin St. wing on the sixth floor. Our illustration shows a view of the general office; adjoining it is the private office of Mr. E. F. Kent, which also connects with the director's suite.

The Kent & Stanley Co.'s shop, ever known as a model one, is in the new building better than ever. In one of the illustrations accompanying this article is shown a corner in the silver shop, a line in which the company is winning rapid recognition, and of which some of the productions, notably yachting trophies, have already been the subject of extended mention in the CIRCULAR.

A pioneer in selling its goods directly to the retail trade, the company, through its ten traveling salesmen and New York, Boston, Philadelphia and San Francisco offices offers a wide and varied line of goods. Some idea of its scope can be gathered from the fact that among them are:

**THE KENT & STANLEY CO.**

One-tenth and one-quarter Gold Seamless Wire Chains; Gents' Rolled Plate Vests, all Seamless Wire, 1, 2, 3, Strand Curbs; Dickens, Trace, Rope, Single Curb, Boston



VIEW OF GENERAL OFFICE.

and Fancy Links; Red Gold and Platinum Links in all styles; Ladies' Lorgnette, Neck, Vest and Victoria Chains; 1,500 styles Gold, Silver and Plated Locketts and charms; White Stone Lace Pins and Brooches; Hair Ornaments; Chain Bracelets, Plate and Sterling Silver; Hat, Hair, Stick, Scarf and Bib Pins; Plated Sword Corsage Pins; Bracelet and Eye-Glass Chains.

In Sterling Silver Novelties, all warranted Sterling Silver are: Garters, Collarettes, Pocket Combs, Tie Holders; Belts with Silver, Pearl and Tortoise Shell Buckles, Paper Cutters and Weights, Match and Stamp Boxes, Trays, Letter Clips, Letter Openers, Book Marks, Prayer Book Marks, Thermometers and Calendars, Satchel Tags, Hat Marks, Coat Hangers, Souvenir Spoons, Umbrella Clasps, Pearl Teething Rings and Rattles, Glove Hooks, Button Hooks, Glove Stretchers, and Hat Buckles, Hair Pins in Celluloid, Real Tortoise Shell, Silver Mounted; Tooth Brushes, Shoe Horns and Letter Seals, Mirrors, Game Counters, Cigarette Cases, Sword Corsage Pins, Key Ring Chains, Bonbon Spoons, Pocket Knives, Scissors, Razors, Manicure Articles, Gold and Silver Mounted Suspenders, Novelties in Leather Card Cases, Memorandum Books, etc.; Stag Handle Cutlery Novelties, Corkscrews and many others.

The company issued last year one of the finest illustrated catalogues ever put out by a jewelry house and another is now in preparation which will be even better than

**THE KENT & STANLEY CO.**

its predecessor, if that is possible. The business of the present Kent & Stanley Co. was first established in 1873 under the style of William H. Robinson & Co.,

**THE KENT & STANLEY CO.**

surviving partners, Edwin F. Kent and Arthur W. Stanley, under the old firm name. In 1887 these gentlemen purchased Mrs. Robinson's interest and continued under the style of Kent & Stanley. Under the new impetus, business during the two following years was doubled, but on Feb. 19, 1888, another fire once more interrupted operations by burning the factory entirely to the ground. Another shop was immediately found by Mr. Kent, and by noon of the day following the fire new machinery was already being put in position at the new shop, an instance of his indomitable will and prompt action in an emergency to which is due in a large measure the firm's success and high position to-day.

A lease of the ground on which the burned building had stood was quickly secured, and without the least unnecessary delay, Kent & Stanley began the erection of a building suitable to the needs of jewelry manufacturers which, when completed, ranked among the best factory buildings in the city. The firm took up its quarters in it and continued with increasing success. In February 1891, it was incorporated, under the title of the Kent & Stanley Co., being capitalized at \$300,000, represented in real property, and with charter rights for half a million. In November, 1893, the constantly increasing business necessitated larger quarters and the balance of the treasury stock was issued. In July, 1894, this additional stock had been issued, paid for in cash and invested in the new plant, which forms the subject of this article. It represents an investment of about \$350,000, and the total capital and surplus of the company in-

at 25 Calendar St. and the output consisted of chains. In 1882 Mr. Edwin F. Kent became a member of the firm and at once took an active interest in its welfare. In 1884 occurred the disastrous fire still remembered by the citizens of Providence, in

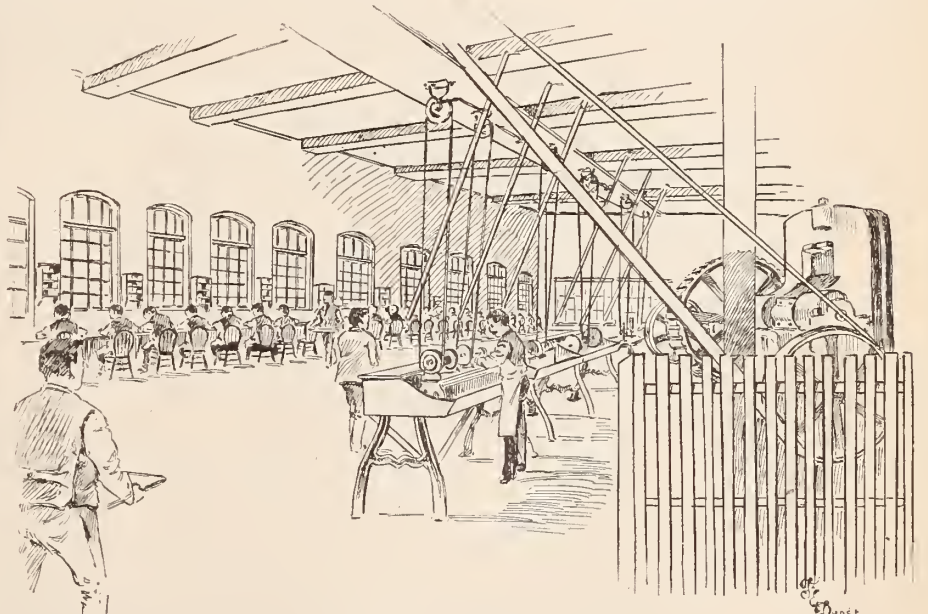

A CORNER IN THE SILVER SHOP.

which the factory was destroyed. New quarters were found at 7 Eddy St., and operations were again resumed. In 1885 Mr. Robinson died, and for nearly two years the business was conducted by the

vested in business is \$650,000. Its officers are: president, A. W. Stanley; treasurer, E. F. Kent; vice-president, J. S. Ingalls; secretary, J. D. Warren. George R. Clarke is superintendent and designer.

**DIAMONDS.****Wm. S. Hedges & Co.,****Importers of Diamonds,**

And Manufacturers of DIAMOND JEWELRY.

**170 Broadway, New York.**

22 Holborn Viaduct, London.

**Alfred H. Smith & Co.,****IMPORTERS****DIAMONDS**

AND

**PRECIOUS STONES,****82 BROADWAY, COR. JOHN STREET,****NEW YORK.**

22 Holborn Viaduct, London, E. C.

**R. A. KIPLING,****Precious Stones**AND **Fancy Goods****Bought and Sold on Commission.****19 RUE DROUOT,****PARIS, FRANCE.****ONE YEAR'S SUBSCRIPTION**

—TO—

**The Jewelers' Circular**

—At \$2.50,—

Entitles the subscriber to a copy of "WORKSHOP NOTES" free, a 200 page book, bound in cloth, containing a fund of information for the workshop that can be found in no other work.

**Philadelphia.**

Frank Rouse, of Bailey, Banks & Biddle, has been celebrating the appearance of a son and heir.

Edward Allen, successor to Isaac Dixon, has removed from 124 S. 11th St. to 13th and Walnut Sts.

J. E. Limeburner & Co., opticians, have removed to 1407 Chestnut St., three doors below their late location.

George W. Scherr and Chas. S. O'Bryon attended the New York Jewelers' Association banquet in New York.

Jacob Muhr has been appointed a member of the Jackson Day banquet committee of the Young Men's Democratic Association.

Simons, Bro. & Co. will distribute a unique '95 calendar on Thanksgiving Eve. The design is said to be a distinct innovation.

J. H. Kelly, James A. Barry and A. G. Lee are the committee having charge of the musical smoke at the Jewelers' Club, on Tuesday evening, Nov. 27.

F. L. Archambault, formerly in business on Market St., near 2d St., and afterwards on 11th St., is now in charge of a department with Bailey, Banks & Biddle.

Visiting jewelers on purchasing missions here the past week included: E. S. Morgan, Fogelsville, Pa.; A. Doran, Mount Holly, N. J.; John Fish, Bryn Mawr, Pa.; B. C. Foster, Bristol, Pa.

Percy Williams, colored, pleaded guilty in Quarter Sessions, last week, to the larceny of a gold watch case from the store of William Silverstein, and was sentenced to two years in the Eastern Penitentiary.

The window of H. R. Saunders' optical store, 133 S. 13th St., was smashed early on Tuesday morning last, and a number of gold spectacles were stolen. This is the second time that the store has been robbed in the same way within six months. John H. Williams, of New York, was subsequently arrested for the offence, and was held in \$1,200 bail for trial by Magistrate Pole.

A defective flue caused a \$1,000 fire on Sunday week at the optical store of Williams, Brown & Earle, 39 S. 10th St. A reserve officer saw the flames issuing from the second story window and he turned in a local alarm, but the flames spread so rapidly that other engines were sent for. After nearly half an hour's work the flames were extinguished. Almost all the damage was on the stock.

*Waterman and Lehmann,*  
Manufacturers of  
**Diamond Jewelry**  
AND DEALERS IN  
**Diamonds.**  
*No 37 Maiden Lane*  
*New York.*

**KELLER, ETTINGER & FINK,**

SELECTION ORDERS SOLICITED.

**24 JOHN STREET, NEW YORK.**

DEALERS IN

MOUNTERS OF

IMPORTERS OF

**American Watches.****Fine Diamond Jewelry.****Diamonds.**



**Boston.**

The collection of ancient Icelandic silver and silver gilt ornaments, exhibited by Mme. Sigride Magnusson at the World's Fair, has been placed for the present in the Boston Art Museum. The collection is to be sold for the benefit of the first college for women in Iceland.

The New England Association of Opticians held their regular monthly meeting at Young's Hotel, Monday evening. The meeting was addressed by Alvan G. Clark, of Cambridge, the famous telescope maker, and Dr. Lewis S. Dixson, of Boston, talked also on the use of the Javal ophthalmometer, and of homatropine.

At a recent experimental test, made by Prof. Hale, of the Yerkes observatory of Chicago University, the great 40-inch telescope now under construction by Alvan G. Clark, of Cambridge, was pointed at Mars, and the results were so satisfactory as to secure from Prof. Hale the assertion that the new telescope far exceeds in light collecting ability any instrument that he has previously turned upon the planet.

Buyers in town the past week included: George T. Springer, Saccarappa; E. E. Shedd, Eastport; G. R. Doak, Vinal Haven; A. W. Greely, Ellsworth, Me.; G. E. Ross, Vergennes, Vt.; Mr. McLaughlin, representing G. W. Darling, Whitefield, N. H.; S. A. Clark, North Brookfield; G. H. Foye, of George Foye & Son, Athol; Mr. Munroe, of Munroe, Carter & Co., Southbridge, Mass.; E. Jacot, of E. Jacot & Co., Quebec; D. McLean, Weston, N. S.

Louise Kaufman, known to the police in Chicago and other western cities, also in several southern sections, operating in times past at Louisville, Nashville, Atlanta and Charleston, and noted as a victimizer of jewelers by substituting worthless rings for diamonds shown her, was arrested Tuesday on the charge of shoplifting in several Boston stores.

G. W. Wells, president of the American Optical Co., was in town during the past week, being interested in the result of a case then pending in the Circuit Court. E. Kirstein's Sons & Co., Rochester, N. Y., obtained, as the outcome of the proceedings in court, Friday, a permanent injunction against Ernest De Celles, Southbridge, Mass., restraining him from manufacturing a so-called "four bar" spring, used on eyeglasses, which is an infringement on the Kirstein patents on a spring known to the trade as a "three bar."

In the United States Circuit Court of Appeals, last Wednesday, a decision was made in the case of the United States against Frank J. Wetherell, importer of iron and steel in this city, to the effect that cold rolled cast steel, for use in the manufacture of clock springs, was subject to an ad-valorem duty of 50 per cent. under the tariff act of 1890. This reverses the judgment of the Circuit Court, which held that the imported article was dutiable at 2 cents per pound. The invoice value is about 6½ cents per pound.

ESTABLISHED 50 YEARS.

LANDEL, BAREMORE & BILLINGS,

IMPORTERS OF

DIAMONDS,

AND OTHER PRECIOUS STONES.

FINE PEARLS A SPECIALTY.

MANUFACTURERS OF

DIAMOND JEWELRY,

IN THE LATEST DESIGNS.

Diamonds Recut in Modern Styles or Repaired on Premises.

58 Nassau Street,  
29 Maiden Lane,  
NEW YORK.

1 Tulp Straat,  
AMSTERDAM.

1 St. Andrews St.,  
Holborn Circus,  
LONDON, E. C.



TRADE MARK.

ESTABLISHED 1841.

CARTER, SLOAN & CO.,

MANUFACTURERS OF GOLD JEWELRY,

No. 15 MAIDEN LANE,

NEW YORK.

A. CARTER JR  
A. K. SLOAN.  
C. E. HASTINGS.

GEO. R. HOWE  
WM. T. CARTER  
WM. T. GOUGH.

FACTORY, NEWARK, N. J.

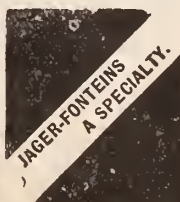

JOHN N. DISSELKOEN,

Cutter and Importer of

DIAMONDS

FACTORY  
76 LANGEBLEEKERSPAD  
AMSTERDAM.

19 East 16th St.,  
NEW YORK.

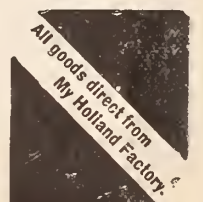



Traveling representatives may consider these columns open for the publication of any news or items of interest regarding themselves or their confreres.

**A**MONG the traveling men in Lancaster, Pa., the past week were: S. Aronsberg, John Scheidig & Co.; F. M. Wheeler, Dominick & Haff; F. W. Bliss, Unger Bros.; J. F. Crane, Mandeville, Carrow & Crane; John W. Sherwood; A. J. Lasher, Whiting Mfg. Co.; S. Glenn Walmsley, Tenner & Baum; M. Waterman, Waterman & Lehmann; L. A. Burt, R. Wallace & Sons Mfg. Co.; H. Allyn Parker, Bassett Jewelry Co.; J. W. Block, with Charles Knapp; Henry Ansley; Richard G. Ledig; J. H. Thompson, Bioren Bros.

H. L. Sherman, traveler for Simpson, Hall, Miller & Co., just returned to Chicago from Ohio, says the State seems to be in good shape and the condition of business much improved since the election.

Traveling salesmen visiting Davenport, Ia., jewelers during the past week were: Leo Henle, Sussfeld, Lorsch & Co.; Louis Hirsch, Lissauer & Co.; C. J. Roehr, Bassett Jewelry Co.; C. F. Livermore, Middletown Plate Co.; F. R. Horton, Carter, Sloan & Co.; John E. Bucher, Rogers, Smith & Co.; M. Hollister, Hayden W. Wheeler & Co.;

T. H. Pope, for Frank W. Smith, and D. Goldberg.

Traveling men in Indianapolis last week included: Wm. W. Middlebrook, B. A. Ballou & Co.; P. A. Porter, R. Wallace & Sons Mfg. Co.; G. W. Bleecker, Bassett Jewelry Co.; John S. Jepson, Byron L. Strasburger & Co.; J. E. Blake, Blake & Clafin; Geo. L. Paine, E. I. Franklin & Co.; Jos. Becker, Jos. Fahys & Co.; A. Marshutz, Spencer Optical Mfg. Co.; Mr. Keene, Ostby & Barton Co.; a representative of Hirsh & Hyman; F. W. Trewin, Keystone Watch Case Co.; John Lamb, T. I. Smith & Co.

The following traveling salesmen were in Louisville, Ky., last week: Mr. Dean, Reed & Barton; Richard M. Adler, The Adler Veneer Seat Co.; Robt. Wilcox, Wilcox & Evertson; I. W. Friedman; Mr. Ashton, Kent & Stanley Co.; W. C. Coombs, Edw. F. Sanford & Co.; C. B. Burgess, F. M. Whiting & Co.; Chas. Marx, Falkenau, Oppenheimer & Co.; J. Rothschild, for I. M. Berinstein; Harry Osborne, Whiting Mfg. Co.; Louis Lassner, Goodfriend Bros. & Lassner; Thos. H. Ryland, J. B. Bowden & Co.; J. N. Beckwith, Joseph H. Fink & Co.; Louis Bernheim, Leopold Weil & Co.; H. B. Vincent, Simpson, Hall, Miller & Co.; Fred Mockridge.

Representatives of wholesale houses calling on the trade in Syracuse the past week were: B. E. Osgood, Bioren Bros.; Fred Clarkson, Snow & Westcott; G. C. Booth, Hutchison & Huestis; Monroe Engelsman, for Maurice Weil; Geo. S. Melville, The Acme Silver Plate Co.; Mr. Keil, White, Howard & Major; J. L. Granbery, D. D.

Codding; Mr. Gregory, Strobell & Crane; Dan F. Pickering, for C. K. Colby; Wm. J. McQuillin, Hodenpyl & Sons; Chas. T. Dougherty, Sexton Bros.; Frank G. Moyer, Max Freund & Co.; Mr. Bride, S. Cottle Co.; J. Goldberg; F. M. Neefus, for William Link; Dayton W. Reed, Belknap, Johnson & Powell; Mr. Bixby, Frank W. Smith; P. R. Ketcham, Brooklyn Watch Case Co.; L. Laubheim, Adolph Goldsmith & Son; Floyd Neely, A. H. Smith & Co.; Mr. Sherry, Jos. Fahys & Co.; Mr. Beatty, Waite, Mathewson & Co.; Mr. Blake, Barden, Blake & Co.; J. J. Robinson, Greene & Knox Mfg. Co.; Theo. L. Parker.

Traveling salesmen swamped the trade in Detroit last week. Among them were the following: Fred A. Ray, Darling Smelting & Refining Co.; Mr. Battey, Waite, Mathewson & Co.; Mr. Davis, B. S. Freeman & Co.; S. Levy, S. Levy & Co.; C. O. E. Hartung, Sussfeld, Lorsch & Co.; George Payne, E. I. Franklin & Co.; Alfred Varian, Dennison Mfg. Co.; Stephen B. Kent, William H. Ball & Co. and George O. Street & Sons; Louis E. Smith, M. B. Bryant & Co.; John W. Case, for H. F. Carpenter; Frank E. Alden, Hayden W. Wheeler & Co.; Robert Welch, Welch & Miller; Chas. W. Hempel, Sandland, Capron & Co.; Mr. Schwab, New Haven Clock Co.; Geo. W. Bleecker, the Bassett Jewelry Co.; L. V. Benson, for Frank H. LaPierre; W. J. Carrow, Mandeville, Carrow & Crane; Thos. E. Rogers, Hayes Bros.; Mr. Brooks, Brooks & Pike; Wm. D. Elcox, Larter, Elcox & Co.; E. S. Shepherd, R. F. Simmons & Co.; G. W. Hull, Silver Plate Cutlery Co.; W. H. Bryant, T. G. Hawkes & Co.

## Great Sacrifice Watch Sale.

A RARE OPPORTUNITY TO BUY FINE WATCHES

BELOW THE PRICE OF ORDINARY.

Having decided to discontinue the "Complete Watch" branch of our business and to hereafter confine our trade exclusively to watch movements, we offer our large and superb stock of Paillard Non-Magnetic Ladies' and Gentlemen's Fine Gold Watches, Plain and Complicated, at prices less than manufacturing cost. These watches are high class and carry with them our full warrant and guarantee.

This entire stock must be closed out, regardless of cost, before January 1st, to make room for regular movements. If you have a trade in Fine Watches, or appreciate high class goods, or if you have a customer to whom you can sell a Fine Watch, this is the greatest opportunity ever offered and

ONE YOU SHOULD TAKE ADVANTAGE OF.

Selection Packages sent to responsible dealers. Parties unknown to us will please furnish New York references. Descriptive "Sacrifice Sale" Circular mailed upon application.

A. C. SMITH WATCH CO., 177 Broadway, New York.

Edward E. Hall, formerly traveling man for E. H. Saxton & Co., Boston, Mass., has accepted a position as salesman for J. B. Humphrey, successor to H. T. Spear & Son.

Traveling salesmen in Philadelphia Pa., the past week included: Frank L. Wood, Carter, Sloan & Co.; S. O. Bigney, S. O. Bigney & Co.; J. E. Simonson, A. J. Hedges & Co.; Frank I. Locklin, Unger Bros.; F. H. Cutler, Cutler & Lull; James A. Cheney, Ludwig Nissen & Co.; B. H. Noble, Payton & Kelley; Thos. Frothingham, Thos. Frothingham & Co.; Edward Eckfeldt, W. B. Kerr & Co.; Chas. Frances, Hancock, Baker & Co.; Leverett P. Lewis Randel, Baremore & Billings; William Arthur, Newark Watch Case Material Co.

Traveling men visiting the Hub the past week included: W. H. Tarleton, Wightman & Hough Co.; James F. Barclay, R. Wallace & Sons Mfg. Co.; Charles T. Gallagher, Sinnock & Sherrill; Mr. Somes, S. O. Bigney & Co.; D. Untermeyer, Keller & Untermeyer Mfg. Co.; Herbert C. Barker, J. W. Reddall & Co.; John Taylor, Kremenz & Co.; A. A. Wood, Howard Sterling Co.; Mr. Bartlett, Whiting Mfg. Co.; A. C. Van Houten, for C. Sydney Smith; E. W. Martin, Martin, Copeland & Co.; Mr. Stern, Young & Stern; J. D. Pettengill, Derby Silver Co.; C. Tiffany, F. H. Sadler & Co.; J. C. Wolstenholme; B. C. Crandall, Crandall & Pardee; J. W. Presbrey, Presbrey & Williams; Winfield S. Luther; B. S. Freeman, B. S. Freeman & Co.; H. Wexel; E. R. Crippen, Bates & Bacon; Fred. H. Carpenter, R. F. Simmons & Co.; George Whiting, S. E. Fisher & Co.; Charles L. Power, Ludeke & Power; Herman A. Friese, Lewis, Kaiser & Luthy; Frank Jeanne, William S. Hedges & Co.; Fred. I. Marcy.

Jacob Rosenbloom is under arrest in Elmira, N. Y., on a body execution. He is alleged to have sold a watch to a woman under the pretense that it was gold, when it was found to be brass. A judgment was secured against him in suit, and an execution was issued.

**Springfield, Mass.**

Woods & Hosley have been awarded the contract for furnishing the class pin for the sophomore class of the high school.

The Retail Jewelers' Association will probably meet this week to act upon the constitution and by-laws prepared by their special committee.

The jewelers of Pittsfield have adopted a uniform schedule of prices. They were represented at the Worcester convention of retail jewelers, by E. J. Spall.

**Syracuse.**

E. C. Howe returned Monday from a visit to the metropolis.

Hopper R. Hukins left on Sunday for New York where he is to take a position with the Whiting Mfg. Co. Mr. Hukins was for some years in business in Syracuse.

Among the out-of-town buyers in town the past week were: D. C. McKee, Corning; N. Nightengale, Marcellus; F. A. Phelps and wife, Cato; and C. R. Rogers, Waverly.

**A. WITTNAUER,**

Successor to I. EUGENE ROBERT & CO.,

19 MAIDEN LANE, - - NEW YORK.

**Swiss Watches and Movements**

—OF—

ALL DESCRIPTIONS, STYLES AND SIZES

—AND—

IN VARIOUS GRADES.

**Split Seconds, Minute Repeaters and Novelties.**

ARE YOU PUSHING THE SALE OF

**TRENTON MOVEMENTS?**

IF NOT, WHY NOT?

For intrinsic value and great merits combined, with **LOWNESS of PRICE**, they far surpass any movements ever placed on the market.

A sample line will thoroughly convince you that it will be to your advantage to handle them extensively.



6 SIZE, 7 JEWELS.

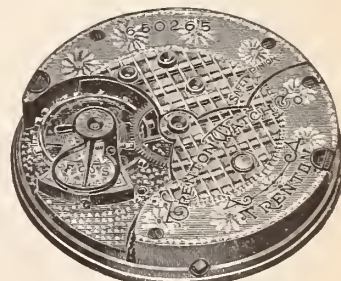

16 SIZE, 16 JEWELS.

INSIST UPON HAVING THEM.

**TRENTON WATCH CO.,**

TRENTON, N. J.

**Los Angeles, Cal.**

Jeweler J. A. Black is shortly to open a store in Phoenix, Ariz.

E. D. Foster, jeweler, Norwalk, Cal., has just passed through a serious illness.

Bailey Bros., Pomona, Cal., are conducting daily auctions of their stock.

The Mayor of San Diego has vetoed an ordinance whereby the city council of that place sought to impose a license of \$15 per day payable semi-annually in advance upon all resident jewelers who should conduct auctions, at the same time charging only \$50 per month for licenses for new establishments. The ordinance applied only to jewelers and seemed to have for its object the prohibition of auctions in the jewelry business.

M. C. Nettleton, jeweler, Albuquerque, N. M., suffered the loss recently of a number of valuable rings grabbed from a case he was showing to a Mexican man and woman. The party swiftly ran out of the store and eluded capture for some hours; meanwhile they had succeeded in selling some of the rings and probably concealing the others; two of the diamonds have been recovered from the parties to whom they were sold, and returned to Mr. Nettleton.

W. H. Speck, Palatka, Fla., has removed his jewelry establishment into the store in the Kean block, corner Lemon and Front Sts.

**Pittsburgh.**

J. Alex. Hardy is in New York buying holiday goods.

Samuel Till has opened an office corner of Fifth Ave. and Market St.

August Loch has been making many improvements in his Allegheny stores.

Hardy & Hayes are making additions to their Fletcher system of shelving in their store.

A. F. Fleming, McKeesport, Pa., and W. F. Brehm, Rochester, were in the city last week.

Emma Kaufman Cerf is the name of a dainty little maiden who recently came into the household of Herman Cerf.

Charles Wattles went east last week on business, to see the Horse Show, and to attend the jewelers' banquet.

Joseph M. Schaefer has removed to the rear of his former rooms and is now busily engaged in the jobbing trade.

J. F. Watt, who recently opened a store at Freeport, Pa., has been very ill lately, and will go south in a few days.

Al. Covert has been recently engaged by West, White & Hartman, to work city trade and that of surrounding towns.

H. Moore, manager for Kingsbacher Bros., has accepted a position with an eastern optical firm for a season upon the road.

Will Terheyden, a former partner with

Jos. M. Schaefer, is now with his brother, Henry Terheyden, and will shortly go east to learn the manufacturing business.

A very quiet marriage was that of Miss Catherine Beall, of Fremont St., Allegheny, to Ira Reidenbach, on Wednesday afternoon, Nov. 14. The groom is a jeweler of Riverton, Pa.

M. J. Smit and K. Smit, for many years engaged in the jewelry business here, have decided to sell out and enter other business. They opened an auction sale last week.

"T. P. Bedilion, agent," is the sign at 39 Sixth Ave. which has been attracting the attention of the trade during the last few days. Mr. Bedilion is a former Pittsburgh jeweler who will open a new store at the above location about the first of the month.

William H. Dawson, of the jewelry firm of Wallace & Dawson, Smith's Ferry, accidentally shot himself, on Nov. 14. His store had been robbed twice, as reported in THE CIRCULAR, and on last Tuesday night he arranged a gun in his store with wire attachments to the window, so that the gun would explode if the windows were disturbed. On Wednesday morning when Mr. Dawson opened his store he forgot about his deadly trap, and attempted to raise one of the windows. The contents of the gun entered his stomach. He died in Allegheny, while being brought to a hospital. Mr. Dawson was a single man, aged 30.

# WANTED

25 first-class **DIAMOND CUTTERS** and **POLISHERS.**

Also an **A No. 1 CLEAVER.** None except such that are capable of filling the position should call at the Astor House, Room 110, 2d floor, between 7 and 9 a. m., 1 and 2 p. m., and evenings from 6 to 7, up to December 1st.

**FOX BROS. & CO.**

**Genuine "Horsey" Jewelry and Silver.**

YEAR after year New York's aristocracy have patronized the Horse Show until the event has become a marked feature of the social season, and not to be seen at Madison Square Garden during the meet of the blooded horses is to abjure society. Naturally this show of fine stock has tended to bring out fashions in dress and equipage which shall brand the wearer as "horsey" without being sporty. The hunting crop laid by for a year is carefully dusted and carried instead of a cane. Top boots and riding gaiters are affected, and each visitor strives to rival his neighbor in the attempt to appear as if just from the stable or paddock.

In past years, however, little has been done by jewelers in recognition of this rapidly growing interest in "horsey" matters. A cigarette case now and then was seen with some ornamentation suggestive of the hunt or race track, or perhaps an imported match box or scarf pin would give its possessor the much coveted equine air. But to the Gorham Mfg. Co. belongs the credit of introducing a distinctively "horsey" line of trinkets which has created almost as great sensation in society as the thoroughbreds themselves.

For months expert silversmiths and the cleverest of designers have been quietly at work upon these novelties and the clubman or his fair companion now has a wonderful collection from which to choose a souvenir. And not only has fancy been given a loose rein in the way of odd conceits, but most remarkable of all, the details are as carefully carried out as if the delicate little ornaments were intended for models of actual trappings. The work is all applied so that each pattern shown in relief is really a miniature of the original. Again where leather is used in these goods, pigskin (used so extensively in harness and saddlery manufacture) is substituted for the more common leathers.

Silver stirrups, spurs, boot pulls, whip handles, flasks, etc., are among the more practical examples of the new departure, and some of them are elaborately decorated. A lorgnette having for a handle a tiny coach whip makes a very chic addition to the young society woman's jewelry case; also a watch, the case of which is decorated with a fanciful design showing bits, stirrup, straps or one of the many smaller bits of harness.

Cigarette or cigar cases in many instances have an enameled picture of hurdle jumping or the likeness of some world famous thoroughbred, whose curving neck and clean cut flank are so true to life that it seemingly needs only the crack of a coach whip to send him off at a gallop. On a stamp box is the representation of a saddle, not a fanciful design intended to fit the box, but an absolutely perfect bas-relief of an English racing saddle.

Dashboard clocks, corkscrews, scarf pins, brooches and a bewildering assortment of miscellaneous trinkets make up one of the most fascinating displays ever put on the counter of a house which is noted the world over for its beautiful ideas in metal work.

The Horse Show will go the way of its predecessors, a grand success, too soon forgotten in the whirl of a giddy Winter; but the "horsey" silverware of the Gorham Mfg. Co. has made such an impression that it is bound to become a staple line in the market.

**The \$10,000 Richard K. Fox Championship Belt Stolen.**

DAVENPORT, Ia., Nov. 17.—The theft of the Richard K. Fox championship belt, which was announced from the stage of the opera house Sunday evening by Prizefighter Corbett, was at first pronounced an advertising fake by many people. The evidences of the theft were indisputable, but it was said by these people that some hired men of Mr. Corbett's had broken into the drug store where the belt was on exhibition, and that pretty soon the trophy would turn up

all right and with its fame greatly enhanced. In short, it was alleged in pretty near so many words that Mr. Corbett had stolen the belt from himself.

But after personal talks with Mr. Corbett and G.E. Williams, a shrewd member of the secret service, who came here at once from Chicago in response to a request wired him by Mr. Fox, I believe that this theory is untenable, unless Mr. Fox is a partner to the scheme, which is hardly probable. A reward of \$500 and no questions asked has been posted here. It should be added that Corbett was very successful in concealing the concern that the ordinary man would feel at losing \$10,000 at one sitting, and if the belt turns up soon and no questions are asked it will be highly possible that the whole affair belongs in the class of fakes in which actresses and their jewelry have figured exclusively in the past.

C. E. Winslow, Crawford, Neb., has a suit in attachment against him for \$500. He has given a chattel mortgage for \$716 and his store is closed.

**THE FLETCHER PATENT Wall Case Tray System**

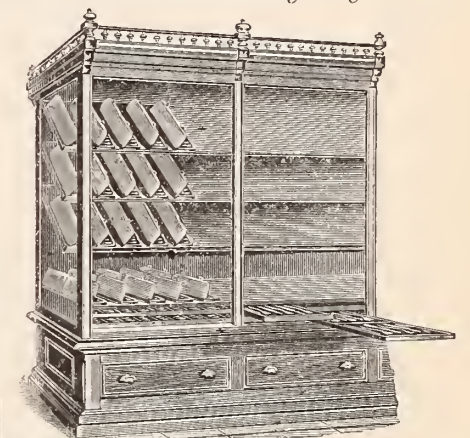

Complete lines of goods carried in the Trays. Samples shown in plush boxes on the shelves.

**FLETCHER MFG. CO.,**  
259 W. 27th ST., NEW YORK.



Just Received Our Fall Importation.

**THE AUDEMAIR OPERA GLASSES, SPENCER OPTICAL MFG. CO.,**

15 MAIDEN LANE, NEW YORK.

CALL OR WRITE. IT WILL DO YOU GOOD!

**ONE OF THE 400, AND VERY SWELL INDEED.**

**THE PERFECT FIT OF OUR No. 918 GOLD EYE GLASS, SWELL END EYE WIRE.**

Our Ambition to Make a FAULTLESS GOLD SPEC. and Eye Glass has been realized, and is appreciated. Strength and Beauty Joined Together WITHOUT SOLDER. You "see that hump" no longer. It's gone, and in its place, at ends and bridge, you find that GRACEFUL SWELL, as shown in cut. *This is the Modern and Perfect Frame the public are asking for, made in all weights, sizes, shapes and qualities.*

WE MAKE ALL KINDS OF OPTICAL SPECIALTIES, AND TEACH HOW TO GET BEST RETURNS IN HANDLING THEM.

The Best Made for the Least Money. Also Cheaper Grades. The Greatest Variety of Styles. Great Reductions to Correspond with New Tariff and Other Causes. SEND FOR NEW SUPPLEMENT.



# CLASSIFIED INDEX TO ADVERTISEMENTS.

All Advertisements are entitled to one insertion under proper heading. Extra insertions, \$6.00 per annum  
Extra Headings, \$12.00 per annum.

<b>Art Pottery, Bric-a-brac, Etc.</b>	Page.	<b>Gold and Rolled Plate Jewelry.</b>	Page.	<b>Sample Trunks.</b>	Page.
Bawo & Dotter, 26 to 32 Barclay St., N. Y...	53	Foster & Bailey, Providence, R. I.....	13	Crouch & Fitzgerald, 161 Broadway, N. Y....	5
Bing, Ferdinand & Co., 106 Grand St., N. Y..	50	<b>Gold Jewelry.</b>		<b>Show Cases.</b>	
Bradley & Hubbard Mfg. Co., Meriden, Conn	12	Aikin, Lambert & Co., 19 Maiden Lane..	12-54	Smith, B & W. B., 220 W. 29th St., N. Y.....	56
Glaenzer, Leon J. & Co., 80 & 82 Chambers St., N. Y.....	3	Carter, Sloan & Co., 15 Maiden Lane, N. Y...	31	<b>Silver Plated Ware.</b>	
Hinrichs & Co., 29 & 31 Park Place, N. Y....	55	Cross & Beguelin, 17 Maiden Lane, N.Y.....	4	Bell, O. E. & Co., 51 E. 4th St., Cincinnati O.	41
Leonard, P. H., 76 & 78 Reade St., N.Y.....	52	Hedges, A. J. & Co., 6 Maiden Lane	16	Pairpoint Mfg. Co., New Bedford, Mass. ....	5
Le Boutillier & Co., 860 Broadway, N. Y.....	15	Larter, Elcox & Co., 21-23 Maiden Lane, N.Y	50	Rogers & Bro., 16 Cortlandt St., N. Y.....	20
Levy, Dreyfus & Co., 9 & 11 Maiden Lane, N. Y.....	40	<b>Gold and Silver Novelties.</b>		The Wm. Rogers Mfg. Co., Hartford, Conn... 5	
Straus, L. & Sons, 42 to 48 Warren St., N. Y...	49	Cohen, L. H., 143-145 Elm St. N. Y.....	47	Webster. G. A., Chicago, Ill.....	41
<b>Assayers &amp; Refiners.</b>		Riley, John A., & Sloan Co., Ltd., Broadway and 17th Street.....	54	<b>Sterling Silver Novelties.</b>	
Goldsmith Bros., 63 & 65 Washington		Reddall, John W. & Co., Newark, N. J.....	7	Codding Bros. & Heilborn, North Attleboro Mass. ....	50
Chicago, Ill.....	42	Waite, Thresher Co., Providence R. I.....	46	Hagan, White & Co., 243 W. 23d St., N. Y... 56	
U. S. Smelting & Refining Works, 25 John St., N. Y.....	56	<b>Guards, Scarf Pins.</b>		Kent & Stanley Co., Providence, R. I.....	23-29
<b>Auctioneers.</b>		Security Mfg Co., 7 Astor House, N.Y	50	Richardson, Enos. & Co., 23 Maiden Lane.... 49	
Boyle, Davis & Goodman, 63 5th Ave., N. Y., 611 Pennsylvania Ave., Washington, D. C....	16	<b>Horological Schools.</b>		Royal Silver Novelty Co., 470 Broadway, N. Y	40
Comrie, A. J., 22 John St., N. Y.	45	Parson's School for Watchmakers, Peoria, Ill.	41	<b>Sterling Silverware.</b>	
H. M. Rich & Co., 21 School St., Boston, Mass.....	40a	Philadelphia College of Horology, 623 Heed Building, Phila., Pa.....	40a	Campbell-Metcalf Silver Co., Providence, R. I.	49
<b>Brownie Novelties.</b>		<b>Insurance.</b>		Fuchs, Ferd. & Bros., 808-810 Greenwich St., N. Y.....	48
Griffith, R. L. & Son, 129 Eddy St., Provi- dence, R. I	49	Fidelity & Casualty Co., 140-146 Broadway....	55	Knowles, J. B. & S. M. Co., Silversmiths' Hall, Union Square, N.Y.	39
Wm. Kendricks Sons, Louisville, Ky	50	<b>Jewelry, Silverware and Optical Cases.</b>		Towle Mfg. Co., Newburyport, Mass.....	55
<b>Badges, Medals, Etc.</b>		Steinhaus, T. C., 10 Maiden Lane, N. Y.....	45	Wallace, R. & Sons Mfg. Co., 3 Park Place,	6
Stockwell, E. R., 19 John St. N. Y.	54	<b>Jobbers, Watches, Diamonds, Etc.</b>		Wood & Hughes, 16 John St., N. Y.....	12
<b>Carborundum.</b>		Allen, Benj. & Co., Chicago, Ills.....	16-41	<b>Spectacle and Eyeglass Cases.</b>	
The Carborundum Co., Monongahela, Pa....	54	Aikin-Lambert Jewelry Co., 19 Maiden Lane	12-54	White, W. B. & Son, Boston, Mass.....	12
<b>Chains.</b>		Brethauer Watch and Jewelry Co., Chicago, Ill.	37	<b>Tortoise Shell Goods.</b>	
Kent & Stanley Co., Providence, R.I.....	28-29	Keller, Ettinger & Fink, 24 John St.	30	Potter, W. K., Providence, R. I.....	48
<b>Clocks, French, English and American.</b>		Myers, S. F. & Co., 48 Maiden Lane, N. Y....	56	<b>Tool Manufacturers and Dealers.</b>	
Jacques, Chas., Clock Co., 22 Cortlandt St., N. Y.....	56	Oppenheimer Bros. & Veith, 35 Maiden Lane, N. Y.....	17	Allen, Benj. & Co., Chicago, Ill.....	16-41
Self-Winding Clock Co., 26 Broadway, N. Y..	56	Sproehhle, F. M. & Co., Chicago, Ill.....	43	American Watch Tool Co., Waltham, Mass..	48
<b>Cut Glass.</b>		<b>Musical Boxes.</b>		Moseley & Co., Elgin, Ill.....	41
Clark, T. B. & Co., 860 Broadway, N. Y.....	45	Cuendet, E. L., 21 John St., N. Y.....	45	Oliver, W. W., Buffalo, N. Y.....	40a
<b>Diamond &amp; Precious Stone Importers.</b>		Jacot & Son, 39 Union Square, N. Y.....	40a	<b>Trays.</b>	
Cottier, C. & Sons, 14 Maiden Lane, N. Y....	56	Wolfe, A., 194 Broadway, N. Y.....	39	Fletcher Mfg Co., 259 W. 27th St., New York.	35
Disselkoen, John N., 19 E. 16th St., N. Y..	31	<b>Ophthalmic College.</b>		<b>Trunks and Traveling Bags.</b>	
Falkenau, Oppenheimer & Co., 40 Maiden	56	St. Louis Ophthalmic College, St. Louis, Mo...	41	Crouch & Fitzgerald, 161 Broadway, N. Y....	5
Hedges, Wm. S. & Co., 170 Broadway, N. Y...	30	Chicago Ophthalmic College, Chicago, Ill.....	41	<b>Watch Manufacturers.</b>	
Kahn, L. & M. & Co., 172 Broadway, N. Y....	56	<b>Optical Goods.</b>		A. C. Smith Watch Co., 177 Broadway ..	14-32-47
Kipling, R. A., Hays Bldg., N. Y.....	30	Berger, Albert & Co., 47 Maiden Lane, N. Y..	5	The E. Howard Watch and Clock Co., 141 Maiden Lane.....	2
Randel, Baremore & Billings, 29 Maiden Lane	31	Geneva Optical Co., Chicago, Ills.....	41	Trenton Watch Co., Trenton, N.J.....	33
Smith, Alfred H. & Co., 182 Broadway, N. Y..	30	Queen & Co., Philadelphia, Pa.....	56	<b>Watch Case Manufacturers.</b>	
Tannenbaum, L., & Co., cor. Maiden Lane and Nassau St., N. Y.....	27	Spencer Optical Mfg.Co., 15 Maiden Lane, N. Y.	35	Roy Watch Case Co.....	24
<b>Diamond Cutters.</b>		<b>Pens, Pencils, etc.,</b>		Wadsworth Watch Case Co., Newport, Ky. ..	44
Arnstein Bros., 45 John St., N. Y.....	10	Aikin, Lambert & Co., 19 Maiden Lane, N.Y.	12-54	<b>Watch Case Repairers.</b>	
<b>Diamond Jewelry.</b>		Diamond Point Pen Co., 7 Astor House' N.Y.	45	The Planchamp & Becker Co., Chicago, Ill....	41
Waterman & Lehman, 37 Maiden Lane, N. Y.,	30	LeRoy, Fairchild & Co., 3 Maiden Lane.....	14	<b>Watch Importers.</b>	
<b>Diamond Polishing Mills.</b>		Smith, H. M. & Co., 83 Nassau St.	45	Hyde's, J. E., Sons, 22 Maiden Lane, N. Y..	14
Arthur Co., The, 86 John St., New York.....	56	<b>Photo-Miniature.</b>		Mathey Bros., Mathez & Co., 21 & 23 Maiden Lane, N. Y.....	45
<b>Display-Window.</b>		Favre Leon, 107 East 26th St., N. Y.....	45	Racine, Jules, 180 Broadway, New York.....	55
Pearce, Frederick, 77-79 John St., N. Y..	40a	<b>Ring Makers.</b>		A. Wittnauer, 19 Maiden Lane, N. Y.....	33
<b>Fine Stationery.</b>		Bowden, J. B. & Co., 192 Broadway, N. Y.....	4	<b>Watch Keys.</b>	
Parsons & Greene Co., 18 Murray St., N. Y... 5		Bryant, M. B. & Co., 10 Maiden Lane, N. Y..	12	Clark, A. N., Plainville, Conn.....	38
<b>Furniture.</b>		Hildreth Mfg. Co., 53 Maiden Lane, N. Y....	49		
Smith, Geo. Wm., 3907 Powelton Ave., Phila., Pa.....	39	<b>Safes.</b>			
		Mosler, Bahmann & Co., 518 B'way, N. Y....	16		

## Special Notices.

Rates 75c. per insertion for notices not exceeding 3 lines (25 words); additional words 2 cents each. If answers are to be forwarded, postage stamps must be enclosed. Two insertions, 15 per cent. off; three insertions, 20 per cent. off; four insertions or more, 25 per cent. off. Payable strictly in advance. Display cards on this page will be charged at \$2.00 per inch for first insertion, subject to same discount as above for subsequent insertions.

Under the heading of **Situations Wanted** on this page advertisements will be inserted for **One Cent a Word**. This offer refers to **Situations Wanted only**. Payable strictly in advance. If answers are to be forwarded, postage must be enclosed.

## Situations Wanted.

*Notices under this heading ONLY are charged at one cent a word, payable strictly in advance. If answer are to be forwarded, postage must be enclosed.*

**BY** an American watchmaker, jeweler and salesman with complete set of tools and eight years' experience. Best reference Address Reliable, Box 202, Station A, Meriden, Conn.

**SITUATION** wanted by an A1 watchmaker and engraver; sober and reliable; 16 years' experience; A1 reference; have fine set of tools. P. B. L., P. O. Box 412, Winchester, Ill.

**WANTED**.—A steady position by a first-class watchmaker. Twenty years' experience. Have my own tools. Best of references. A. L., care of JEWELERS' CIRCULAR.

**SITUATION** wanted by a young lady in the business department of either watch, jewelry, silver or kindred trades. Several years' experience. First-class references. New York or Newark preferred. Address C. T. M., care of JEWELERS' CIRCULAR.

**BY** a thoroughly competent and first-class watchmaker, jeweler and salesman; do fair engraving; capable of taking charge of retail store; complete set of full nickel tools; single; age 27; no bad habits; want a good steady job. Address John, care THE JEWELERS' CIRCULAR.

**AN** experienced jeweler, married, German, 36 years of age, seeks a situation preferably in a small city; first class repairer and engraver; sober and industrious. C. F. Keller, Louisville, Ky.

**WANTED**, a position as salesman, after Jan. 1st, in a wholesale or retail jewelry business, by one who is at present engaged with one of the leading jewelry firms in this city. Best of references given. Address A. A. X., care JEWELERS' CIRCULAR.

**WANTED**, a position as expert watchmaker. Experience of 20 years of fine and complicated watches. Best of references. Address Adjustino, care JEWELERS' CIRCULAR.

**WANTED**, Situation as a watchmaker; twenty years' experience at bench work; thoroughly understand repairing of all fine imported and domestic watches and clocks; have own tools. Address James Cantor, 102 2d St., Brooklyn, N. Y.

**SITUATION**, by young man, 2½ years experience at bench in watch, clock and jewelry repairing. North Carolina or Virginia preferred. A1 reference address A. A. F., Ward's Hotel, Wilson, N. C.

**SITUATION** wanted, by practical watchmaker; thoroughly understands all kinds of clocks. Good city references. Address Archard, 208 West St., New York City.

**ENGRAVER** and designer A1, wishes to make an engagement January 1st, 1895. Address Engraver, care JEWELERS' CIRCULAR.

**POSITION** wanted by a first-class watchmaker. Full set of tools. Eighteen years' experience on fine and complicated work. Address C., care JEWELERS' CIRCULAR.

**WANTED**, by a practical jeweler. Experienced foreman and designer, especially diamond work, wishes a position by Jan. 1st. Address A. B., care JEWELERS' CIRCULAR.

**WATCHMAKER**—Eight years on watches and fine clocks (well up in both branches); A1 references; own tools and lathe. Wheel, 99 Clinton Place, New York City.

**SALESMAN**; thoroughly acquainted with western jewelry trade, jobbing and retail, wishes to make a change Jan. 1, have been with present house eight [8] years. Address X., JEWELERS' CIRCULAR, 189 Broadway.

**AN** experienced salesman in watches and jewelry wants a position to travel for a jobbing or manufacturing house in New England. Address M. B. care JEWELERS' CIRCULAR.

**SALESMAN**, with 16 years' established trade in south and west, is open for position as traveler. Address S. H., JEWELERS' CIRCULAR.

**AS OPTICIAN**, engraver or salesman. Best references. Proficient and experienced. Age 30. Address Prof., care JEWELERS' CIRCULAR.

## Help Wanted.

**WANTED**.—A good manufacturing jeweler; one that can do repair work, re-enameling, plating, and set stones. Address A. H. Furstnow & Co., Fond du Lac, Wis.

**WANTED**—First class watchmaker; one able to engrave, with a knowledge of optical work preferred; state age and wages expected. 8 Temple building, Montreal, Que.

**WANTED**—Letter engravers on silverware. State experience and wages expected. Address B. C., care JEWELERS' CIRCULAR.

**WANTED**, salesman, thoroughly acquainted with the large retail trade in the East and Middle States. Must be posted in the watch line. Address B. B., care JEWELER'S CIRCULAR.

**WANTED**, a good engraver for month of December, near New York City. Address M., care JEWELERS' CIRCULAR.

**WANTED**, good engraver, who can assist watchmaker when not busy engraving, for leading store in the southwest. Address, giving age and salary wanted, S. Charles, P. O., Memphis, Tenn.

**WANTED**, young man for manufacturing badges and repairing. One who wishes to improve and learn to do first-class work; can have good advantages. Steady work at moderate price. Address The George H. Ford Co., New Haven, Conn.

**A TRAVELING** salesman to handle a first-class line of jewelry on commission in New York State, Pennsylvania, Ohio or any one or two of the three, calling on the legitimate jewelry trade only in connection with his present line. Address T. 74, care JEWELERS' CIRCULAR.

**A FIRST-CLASS** watch maker and engraver, American born, and a good salesman. Two hours' ride from New York. Address J., care JEWELER'S CIRCULAR.

## Miscellaneous.

**I BUY JEWELRY STOCKS**—Manufacturers, jobbers and retailers desiring to dispose of surplus or entire stocks of diamonds, watches and jewelry can find quick cash buyer by addressing Stephen S. Harmon 1240 Lexington Ave., New York City.

**EXPERIENCED** optician wants space for optical department, with some leading retail jeweler. Address S., care Jewelers' Circular.

## For Sale.

**ASTRONOMICAL** Telescope, 3¼ inch glass, value \$150. Will exchange for diamonds or jewelry. Full description sent. Address Manufacturer, 940 Ave. D., Bayonne, N. J.

## Business Opportunities.

**THE BEST PAYING** jewelry store in Ohio on the money invested. The average profit for the past four years was \$4,343.01 per annum. The stock, with fixtures, will be reduced to \$3,000 by Jan. 1st. This business is the leading one and enjoys the best of reputation in a town of one thousand inhabitants. Must seek a milder climate at once, the reason for selling. Address at once C. W. Ernsting, Gallipolis, O.

**JEWELRY** and optical business, 20 years' stand ing. Best street in Chicago; stock and fixtures, about \$5,000. Can reduce to suit. Have three places, want to sell two and run one right. Good chance for good man. Address Optician, 70 Madison St., Room 11, Chicago, Ill.

**YOUNG** man, 27 years old, practical watchmaker, good salesman and business correspondent; (English, French and German); has been employed five years in America; wants position as interested employe or partner in retail jewelry store or importer's office; can invest \$2,500; references. Address offers with all details as to salary, interest, security, etc. to L. R., poste restante (general delivery), Geneva, Switzerland.

## A RARE OPPORTUNITY

To Buy at a bargain Fixtures and Lease of a 16 years established Jewelry Store on the leading avenue up town in New York City.

Owner retiring from business wishes to close out his Stock of Diamonds, Watches, Jewelry and Silverware before January 1st. Sales have averaged the last five years from \$16,000 to \$20,000, and the amount of repairing from \$3,000 to \$4,000 yearly. Good reference given.

Address A. A., care Jewelers' Circular.

## DIAMOND CUTTING WORKS FOR SALE

12 Mills down-town, most improved, entirely new machinery, good light, could give possession at once. Rent of premises reasonable.

APPLY TO

## THE ARTHUR CO.

86 John Street, New York.

To insure Publication of Advertisement in current week, copy should be received not later than Monday Night.

## OLDEST PUBLICATION

Of all the Jewelry Journals.

Jewelers' Circular Publishing Co.,

189 BROADWAY, NEW YORK.

ESTABLISHED 25 YEARS.

## 17 Jewel Dueber-Hampden Watches

ARE THE MOST RELIABLE WATCHES MADE.

A FULL LINE OF DUEBER CASES AND HAMPDEN MOVEMENT.

Write for New Price List.

**Brethauer Watch and Jewelry Co.,** Special Agents,  
71 WASHINGTON ST., CHICAGO, ILLS.

The Latest Patents.

ISSUE OF NOV. 13, 1894.

**528,960. SELF - WINDING ELECTRIC CLOCK.** ADAM LUNGEN, New York, N. Y., assignor of one-half to Robert Edwards, same place. Filed May 13, 1893. Serial No. 474,118. (No model.)

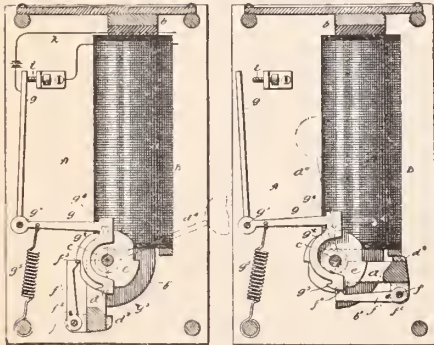

**529,103. ALARM - CLOCK.** THEODORE BIEDINGER and THOMAS J. KANE, New York, N. Y. Filed Nov. 3, 1893. Serial No. 489,898. (No model.)

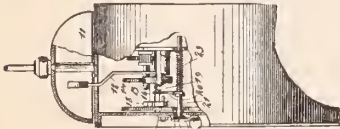

The combination, with an alarm clock having the usual setting or controlling spindle adapted to move in and out in the clock case, and means for automatically pushing the spindle outward on the sounding of an alarm of an external fastening device on the back of the case arranged to hold in the spindle.

**529,178. WATCHMAKER'S POISING-TOOL.** CARL H. LANDGRAF, New York, N. Y., assignor to Henry Zimmern & Co, same place.—Filed June 1, 1894. Serial No. 513,119 (No model.)



In a poising tool the combination with the table or support A, of the adjustable supports C adapted to move toward or from each other in parallel planes, a disk D provided with a handle or lever and indirectly connected with said supports C.

**529,181. JEWELRY-SETTING.** ZACHARIAS A. OPPENHEIMER, New York, N. Y.—Filed November 3, 1893. Serial No. 489,909. (No model.)

A setting for precious stones, etc., consisting of two half sections adapted to fit together and provided each with a shank section and with prongs bent over



to embrace the stone; combined with a base forming an article of jewelry and provided with a socket adapted to receive the shank and to hold the sections together upon the stone, and means as described for securing the shank within the base.

**529,333. ORANGE CUP AND PULP-RE-MOVER.** HENRY MAIER, Allegheny, Pa.—

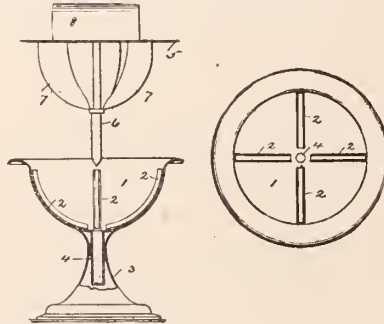

Filed March 14, 1894. Serial No 593,574. (No model.)

**DESIGN 23,788. BADGE.** CHARLES FRED. DORRANCE, Portland, Oreg. Filed Aug. 9, 1894.



Serial No. 519,882. Term of patent 7 years.

**DESIGN 23,789. BADGE.** ISAAC BEDICHIMER,



Philadelphia, Pa.—Filed Oct. 11, 1894. Serial No. 525,636. Term of patent 7 years.

**DESIGN 23,790. UMBRELLA OR CANE HEAD.**

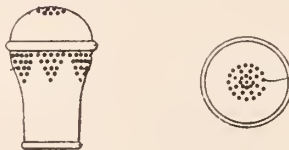

ADDISON CONKLING, Plainfield, N. J.—Filed Oct. 15, 1893. Serial No. 525,991. Term of patent 7 years.

**DESIGN 23,800. METALLIC PATTERN-STRIP.** FREDERICK L. THOMPSON, New Bedford, Mass.,



assignor to the Pairpoint Manufacturing Company, same place.—Filed Jan. 18, 1893. Serial No. 458,867. Term of patent 7 years.

**DESIGN 23,807. GLASS VESSEL.** JAMES J.

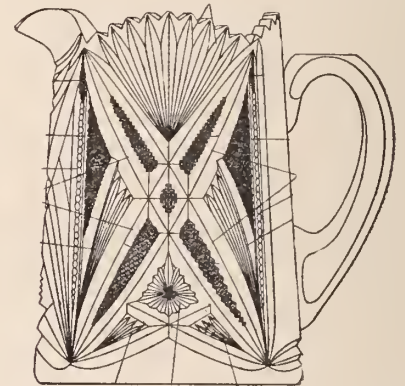

O'CONNOR, White Mills, assignor to C. Dorflinger & Sons, same place.—Filed Sept. 13, 1894. Serial No. 522,946. Term of patent 7 years.

Lewis Girard has started a jewelry store in Woodstown, N. J.

A. C. Kaufman, Carlisle, Pa., has removed from 117 to 22 W. Main St.

The jewelry store of Jacob Gartner, Linneus, Mo., was entered a few nights ago, and watches, rings, etc., valued at \$100, were taken.

Burglars entered the store of Pool Bros., Lamar, Mo., last week, blew open the safe, and took \$150 in cash, \$2,700 in notes, and \$1,500 worth of diamonds. A reward of \$500 has been offered.

Henry G. Booth, 1 State St., Rochester, N. Y., is closing out his stock at auction. The store has been established since 1837. Mr. Booth succeeded his father, E. B. Booth. The sale opened on Nov. 12th and is being conducted by A. J. Comrie, under whose able management Mr. Booth expects to realize cost or over for his entire stock.

The Oneida Silverware Mfg. Co., Limited, to manufacture table, hollow, flat, ornamented ware, silverware, silver plated ware and novelties, in Oneida, N. Y., have incorporated; capital, \$20,000; directors, Sidney W. Moore, of Oneida, Charles H. Wilkin, of Rochester; T. D. Wilkin, of Syracuse, William J. Baker, of Oswego, and Charles A. Simpson, of Munsville.

Sold by all wholesale dealers at manufacturer's price.

A. N. CLARK & SON  
PLAINVILLE  
CONN.

Manufacturer of the Celebrated  
**LOOP WATCH KEY.**

The Best for the Price in the World.  
CROSBY'S JEWELING TOOLS IMPROVED.

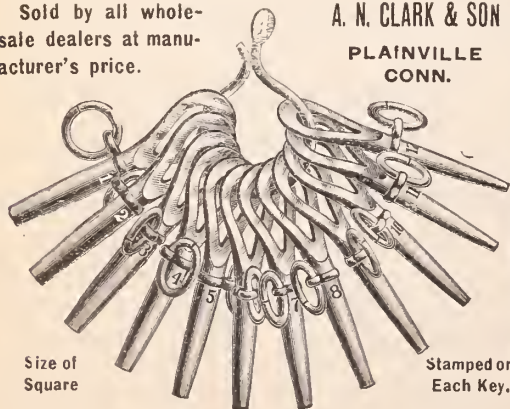

Size of Square

Stamped on Each Key.

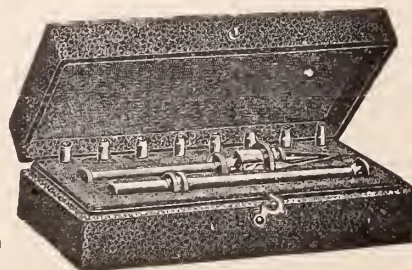

Will quote royalty or price for the manufacturing of articles of real worth.



**Trade Gossip.**

Trenton movements combine intrinsic value, great merits and lowness of price. Are you handling them?

The American Watch Tool Co., Waltham, Mass., report a very encouraging outlook for business. They are now gradually increasing their force and are running on full time.

An attractive novelty is illustrated elsewhere by Codding Bros. & Heilborn, North Attleboro, Mass. This enterprising firm has a large and varied line of quick selling goods in sterling silver novelties which will repay inspection.

Keller, Ettinger & Fink, 24 John St., New York, make a specialty of American watches. The firm are also large importers of diamonds and have a reputation second to none as mounters of fine jewelry. Selection orders are solicited.

L. Tannenbaum & Co., John Street and Nassau St., New York, make an announcement on another page which will prove of interest to every dealer in diamonds and precious stones. This enterprising house proposes to retain its present position in the trade and, if push and energy can do it, will climb still higher.

The illustrated catalogue of musical boxes carried by E. L. Cuendet, 21 John St., New York, should be in the hands of every jeweler who handles these articles. The pamphlet contains 32 pages devoted to descriptions and illustrations of the various styles of musical boxes and tools for repairing, together with many hints that will be of great interest to the dealer. With it is sent a wholesale price list of these articles and terms of discount.

**Canada and the Provinces.**

F. Spangenberg, Kingston, Ont., has moved into handsome new premises.

A. W. Garbutt, watchmaker, Pictou, Ont., has assigned.

Smith Bros., Napanee, Ont., have made extensive alterations to their establishment.

A. H. Harmon, representing the American Waltham Watch Co., was in Toronto Monday last.

A stock of gold and silver watches, clocks, etc., seized by the customs department at Toronto was sold last week at auction.

Joseph Tasker, representing the Canada Refining and Smelting Works, London, Ont., was in Montreal last week and is now doing the Ottawa district.

On Saturday last fire broke out in the roof of the Montreal Watch Case Co.'s building, 124 Vitre St., Montreal, and although the blaze was confined to the roof considerable damage was done by water. The Montreal Watch Case Co. roughly estimate their damages at \$3,000 and the Dominion Rolled Plate Co., who occupied the second story, suffered to the extent of \$500. The damage is fully covered by insurance.

**Details of James M. Reynolds' Mortgage.**

James M. Reynolds, Cohocton, N. Y., sends THE CIRCULAR the following details regarding the mortgage which he recently gave for \$2,200: He sold his old store which had on it a mortgage for \$1,900,

bought a lot and built a new store thereon. He calculates he made by the proceeding at least \$1,800, but had to take some securities that he could not turn into money very readily or to so good advantage as it would for him to give the mortgage.



**GEO. W. SMITH & CO.,**

MAKERS OF

**HIGH · ART · FURNITURE,**

ESPECIALLY ADAPTED FOR

**JEWELRY AND ART TRADE.**

Cabinets, Pedestals, Jardiniere Stands, Onyx Top Tables, 5 O'Clock Tea Tables, Curio and Souvenir Spoon Tables and Cabinets.

**HALL CLOCK CASES.**

FACTORIES,

NEW YORK SALESROOM,

3907-19 Powelton Ave., Phila.

818 Broadway, H. P. Vollmer, M'g'r.

A BEAUTIFUL AND ACCEPTABLE HOLIDAY PRESENT

**THE REGINA MUSIC BOX**

PLAYS ALL THE LATEST SONGS.



New tunes issued every week. Over one thousand are now ready including dances, operatic and all the popular airs of the day.

It is a musical novelty rendering on one or two accurately tuned steel combs the most beautiful music and playing an unlimited number of tunes.

It is the first and only music box manufactured in the United States and far surpasses the finest imported ones. The mechanism is of wonderful perfection and so strong and well finished that with ordinary care it will last for a life time. It runs fifteen minutes with one winding. All its parts are interchangeable. The cases are ornamental and highly polished. The tune-sheets are indestructible, being made of metal and are easily adjusted or changed. Send for illustrated catalogue.

**J. A. WOLFF,**  
194 Broadway, New York.

**The Attleboros.**

TRADE CONDITIONS.

Business has been quite good here the last seven days. There is a good demand for the latest Christmas novelties. At almost every factory there are goodly numbers at work and silverware is in favor particularly.

Thomas N. Smith and Miss Laura Todd were married Wednesday night.

S. H. Bugbee, of Bugbee & Niles, has been appointed inspecting officer of the G. A. R. in Bristol County.

The newest thing in the pin line is a flag pin of silver and enamel. These are for secret societies, clubs and colleges.

At the annual meeting of the Attleboro Agricultural Association Friday night, W. H. Wade, of Wade, Davis & Co., was elected president; J. G. Barden and G. H. French vice presidents; George Randall, secretary; L. M. Holman, treasurer; H. A. Clark, auditor. Among the directors are: E. I. Franklin, G. H. French, E. L. Hixon, C. T. Guild, T. A. Barden, J. G. Barden, W. H. Wade, S. O. Bigney, H. A. Clark,

J. J. Horton, John Thatcher, Henry Wexel, George Randall and F. J. Allen.

Those who departed the past week were: James E. Blake, of Blake & Claflin, for the west; J. J. Freeman, of Freeman & Saart, New England; W. F. Maintien, of J. B. Maintien & Son, New York; B. C. Crandall, of Crandall & Pardee, Maine; James Leary, of Co-Operative Mfg. Co., west; Louis C. Sweetland, Sweetland Bros., New York and the south. Arrivals were: C. H. Williams, Mossberg Co., who has been placing agencies for the American knife sharpener; George L. Sweet, of Hayward & Sweet.

Thursday the silver bi-centennial badges, which were voted at a previous committee of the Bi-Centennial Committee to be presented to President Cleveland and Governor Greenhalge were sent to the two distinguished men by president J. L. Sweet. Each was accompanied by a personal letter from Mr. Sweet. The badges are precisely the same in design as the official badge which was illustrated in THE CIRCULAR previous to the celebration. They are of sterling silver and suitably inscribed on the back. A third badge was struck for Mr. Sweet.

**A Jewelry Thief's Scheme Nipped in the Bud.**

BOSTON, Mass., Nov. 17.—The Boston police placed a man under arrest Tuesday on suspicion, who proved to be a professional thief, but, having no case against him on which he could be prosecuted, railroaded him back to New York. After a couple of inspectors in the retail section had been watching their suspect for some time on the day named, they saw him enter the store of W. J. Knowlton, dealer in gems, on Tremont St. When he emerged they took the liberty of marching him upstairs to the store and asked Mr. Knowlton if he missed anything from his stock. He answered in the negative, but the officers did not credit his story that he desired to purchase a diamond, but could not find one to suit him. At headquarters he admitted that he was a thief known as James Bolton, hailing from New York.

"A woman of very uncertain integrity," is the Bostonese description of a feminine sneak thief caught in the act of robbing a jewelry store, as set forth in the *Transcript*, of that town.

**A Selling Novelty**

**Cup and Saucer,**

With Solid Silver Spoon that can be retailed complete for

**\$1.00.**



Discount to the trade in dozen lots, 33 1/3 per cent. Net Cash, without ribbon.

Cup and Saucer are assorted decoration.

**LEVY, DREYFUS & CO.,**

9 and 11 Maiden Lane, New York.

ART GOODS FOR JEWELERS.

**SCISSORS**

**C FINE CUT GLASS SCENTS C**  
MOUNTED IN STERLING SILVER.  
LARGE AND VARIED ASSORTMENT OF PATTERNS  
.... AND SIZES ....

**E** We are showing New and Exclusive Designs of . . . . **E**  
**N** STERLING SILVER MOUNTED SCISSORS **N**  
AND MANICURE GOODS IN ENDLESS VARIETY.



THE FIDGET.

**T** **ROYAL SILVER NOVELTY Co.,**  
SILVERSMITHS,  
No. 470 Broadway, New York. **T**

**SCISSORS**

## MATTERS IN JEWELRY STOREKEEPING.

That this department shall prove mutually beneficial to our readers, it is desirable that the members of the trade generally communicate with THE CIRCULAR regarding any advantageous device or plan that they are utilizing in the conduction of their business.

### Tiffany's Horse Show.

TIFFANY'S windows, on Union Square, New York, always attract attention. The firm are not given to lavish displays of any kind, but they are students of contemporary events and their exhibits usually possess some special element of interest to the public. Last week, during the much discussed "Portrait Exhibit," fashionable shoppers stood several rows deep in front of Tiffany's window, anxious to get a glimpse of a famous miniature, over 300 years old, of Mary, Queen of Scots, and this week their "Horse Show" window is the subject of many flattering compliments.

The present display, while thoroughly "horsey," bears that elegant touch of refinement so characteristic of the house. The articles shown represent a wide variety of the firm's products of interest in connection with the "Horse Show. There are hand painted menus, with hunt scenes; bronze hackneys and other horses, for cabinets, etc.; riding crops, whips, silver spurs and stirrups, dashboard watches, fans with painted scenes of coaching parties, etc.; boot-pulls and novelties in gold and silver jewelry with horsey designs, etc.

Tiffany & Co. rank among the oldest and most conservative houses in America, and one of the secrets of their continued success is that they keep abreast of the times in their advertisements as well as the general management of their business.

Newton & Co. have one of the best lighted stores in Winsted, Conn. They have just put in three mammoth Juno lamps, nicked and embossed, which furnish a fine, brilliant white light. They are a great improvement.

### Marking Goods in the Show Window.

VISITORS on Broadway, New York, must have noticed recently an unusual sight. This is prices attached to jewelry of the handsomest description and exposed in the windows to the public view. It is customary to see such exhibitions on the Bowery, but Broadway has heretofore kept her price lists indoors.

After all human nature is much the same thing whether on the Bowery or Broadway. It did not seem unlikely that the methods which appealed to the one street might after all not be so far astray on the other. In any case it was interesting to see what the Broadway jewelers themselves thought of the matter. In the case of those who announce the prices the inference is that they believe the announcement advantageous. One dealer confessed that it was an experiment and whether it would prove valuable was yet undetermined. It interested him to make the experiment. Later it was quite possible that he might retire his price tags.

Another dealer said that he believed the frank acknowledgment of the price of his goods to the public to be in accordance with good business methods. "The public saw just what could be bought for the money. If a better bargain could be made elsewhere, the purchaser was at liberty to go elsewhere and no time was wasted by either party."

"Everybody in a big city is busy. A man wants to buy a piece of jewelry as a gift. He knows just about what he wants to pay for it. He can stop at a window and the price marks suggest what he can buy for his money. Then he goes in and buys it without wasting any time. Of course

there are people who like to do everything with deliberation, and enjoy going into a shop, having the contents brought out of their cases, and spending time over a counter. But there are just as many who do not. It is these the price tags in the window are intended to benefit.

"Moreover there are numbers of people who have an exaggerated idea of the cost of jewelry, and particularly of stones. The price marks to these are educational. They see that there is jewelry, pretty and attractive, that meets every one's price. When a purchaser sees a ring for \$25 and another for \$35 he thinks he would rather have the higher priced ring and ten to one gets it."

"I have observed" said one jeweler, "that since I have exposed my prices the numbers of people about the window are greater. Some I know are merely satisfying their curiosity. Everybody likes to know what things cost. Others I am sure are stimulated to buy. The secret of business is to induce people to buy the thing they did not intend to buy."

On the other hand there are jewelers who believe that to expose the prices is to cheapen the articles, and to injure trade. They feel a sense of mortification in having Broadway windows placed on the level of the Bowery. It moreover induces an undignified competition. One dealer knowing his neighbor's prices may undercut him. The entire business might be demoralized in this manner.

Thus the innovation was variously discussed with good reasons as it appears on both sides.



## A MOVING DISPLAY

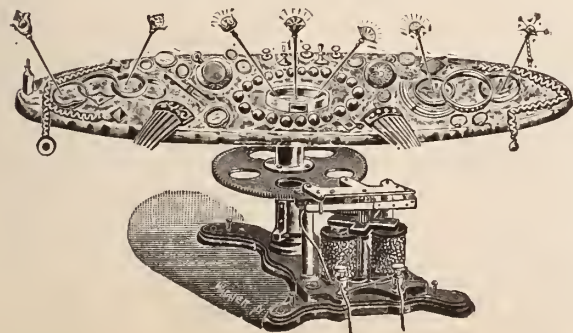

### FOR THE HOLIDAYS.

The Best Attraction in the World a Moving Advertisement in a Window.

### OUR ELECTRIC REVOLVING SHOW STANDS

Are of various styles, made especially for jewelers. They are equivalent to a four fold increase of Show Window space. It runs steadily ten hours per day, at an expense of two cents per day. Made to be operated by either battery or electric light current.

Send for Circular of Illustrations.

FREDERICK PEARCE,

77 & 79 John St., N. Y.

H. M. RICH & CO.,  
Jewelry · Auctioneers,  
21 School Street,  
BOSTON, MASS.

### Philadelphia College of Horology

Is not the largest but is the finest school in the country. A practical school to learn watch-making, engraving, and jewelry repairing. One tuition pays for all branches. Send for prospectus.

F. W. SCHULER, PRINCIPAL,  
1213 Filbert St., Philadelphia, Pa.  
Write for particulars of our corresponding course.

THE EMPIRE WESTWARD TAKES ITS WAY!

# WESTERN SUPPLEMENT

## OF THE JEWELERS' CIRCULAR

Chicago Office: Room 517, Inter-Ocean Building.

VOL. XXIX.

CHICAGO, WEDNESDAY, NOV. 21, 1894.

NO. 17.

### Chicago Notes.

#### TRADE CONDITIONS.

The first half of the week was quiet, but the last half equalled expectations and showed a strong improvement. Disturbing elements are now things of the past and a steadier trade is among the probabilities. While the year thus far has not been what it would be our pleasure to report, there is one bright side—the silver trade. Plated ware houses report that business is running close to '92, and sterling ware houses are fully busy. Nearly everything in the novelty line is a good seller, and factories cannot turn out the new Fall patterns fast enough to suit buyers. This is in lesser measure true of many standard lines. Case manufacturers and the majority of watch houses are not overemployed in filling orders. The general trade is brightening up but the fact that the purchasing power of the consumer has considerably diminished the past year tends to make the recovery less prompt than is usual at this season. Dealers now feel, however, that they can go ahead without fear of legislation interfering with business affairs.

A. L. Sercomb, manager Meriden Britannia Co.'s Chicago house, returned Monday from a visit to the factory.

Frank Cross, formerly with the Columbus Watch Co., is now associated with the Dueber interests as salesman.

Dewitt Bros. have satisfied the mortgage held by J. C. Christman, Jr., and have again taken possession of the store at 43d St. and Calumet Ave.

Mrs. C. M. Walsh, wife of a leading jeweler at Plymouth, Ind., died at her parents' residence in Ellis Park, a suburb of this city, Thursday week.

Henry Matther, who was two years ago in business with his brother at 18 Clybourn Ave., has opened a store on Washington St., near Fifth Ave.

E. J. Hoyer, 228 N. State St., has re-arranged his store, giving increased room, and added brilliancy is effected by new lighting arrangements.

John Baumer, Omaha, Neb., took the occasion of coming to Chicago to attend the wedding of a nephew as an opportune time for laying in a Fall stock.

G. W. Chatterton, Springfield, Ill., was last week in town regarding the settlement of claims against him, growing out of his failure on Dec. 30, 1893.

J. W. Bartlett, Las Vegas, N. M., who last Spring, as is usual with him, closed his store and sojourned in Michigan for the Summer, has returned to Las Vegas and reopened for the Fall and Winter tourist business.

E. J. Walz, Booneville, Mo., is in the city buying goods and expects to open up in that city with an entirely new outfit a few days before Dec. 1. Mr. Walz was for 10 years in the employ of Gimelich & Huber, Booneville.

The Inter-Ocean Wholesale Supply Co. have organized to deal in jewelry, sporting goods and other merchandise. The capital stock is \$10,000, and the promoters are Brode B. Davis, Andrew L. Winters and Frank M. Haradon.

The handsome salesrooms of the Towle Mfg. Co. present a busy appearance these days. The house is fully employed, and the new pattern, the "Empire," an exceptionally choice design, comes in for a large share of praise. Orders are in excess of factory output.

At a meeting of the public service committee of the Cook County Board of commissioners Nov. 9th an order was passed allowing the Pneumatic Clock Co. to put their clocks in the new Criminal Court building on trial. The system consists of secondary dials connected with a master clock, with air pressure as the motive power.

A new optical house (retail) making a specialty of prescription work has been opened at 44 Madison St., by L. L. Ferguson, under the firm name of Ferguson & Co. Mr. Ferguson who was formerly, for 18 months, head fitter for Almer E. Coe, has been connected with the optical business the past 12 years, and is well-known in the trade.

Henry Smythe, charged with using the

mails to defraud A. Coulter, of this city, and others, was arrested in San Francisco and Thursday week left that city in charge of United States Marshall Henry Miller. Smythe's wife asked permission to accompany her husband, which was granted. At Texarkana, Ark., Mrs. Smythe made coffee for the three. Later the marshal was overcome with a drowsy feeling and at Little Rock his prisoner escaped.

An encouragement of the times is shown in an increased number of buyers in town, among them leading tradesmen of their respective localities. Among the firms and individual buyers in the city last week were: John Baumer, Omaha Neb.; Miss Spencer, daughter of John Spencer, Edgerton, Wis.; H. Hartman, Wapokeneta, Ohio; P. H. Kuhn, agent, Quincy, Ill.; M. Homrighans, Tuscola, Ill.; E. Homrighans, Shelbyville, Ill.; J. M. Perkins & Co., Negaunee, Mich.; J. E. Walz, Booneville, Mo.; Geo. R. Strickland, Merrill, Wis.; J. M. Van Slyke, Madison, Wis.; E. W. Bassett, Jacksonville, Ill.; R. W. Chamberlain, Marshalltown, Iowa; E. Lines Mt. Pleasant, Iowa; Mr. Brown, Tiskilwa, Ill.; J. W. Nesham, Ottumwa, Ia.; Eggerman & Son, Aurora, Ill.; P. Harrod, Avon, Ill.; A. Hill, Crystal Lake, Ill.; S. P. Hall, Solomon, Ill.; C. C. Kennedy, Hinckley, Ill.; J. J. Lowrey, Cresco, Ia.; Lundgren & Wilson, St. Charles, Ill.; Albert Miller, Dundee, Ill.; Murray & Williams, Guthrie, Oklahoma; G. F. Mills, Woodstock, Ill.; C. J. Peterson, St. Charles, Ill.; Mrs. F. J. Reemer, South Chicago, Ill.; Stiller Bros., Farmer City, Ill.; W. B. Sherrath, Lake Park, Ia.; J. H. Schaefer, Milwaukee, Wis.; H. G. Tuttle, Otsego, Mich.; G. O. Warren, Sycamore, Ill.; T. H. Webb, Peoria, Ill.; Warley & Hester, Anchor, Ill.; E. Wehmhoff, Burlington, Wis.; W. P. Sloman, Waukegan, Ill.; H. H. Hicks & Son, Momeuce, Ill.; J. C. Avery, Grand Haven, Mich.; J. G. Bodenschatz, Lemont, Ill.; G. F. Beach, Valparaiso, Ind.; D. S. Bowen, Richland Centre, Wis.; J. W. Burkitt, Arlington Heights, Ill.; T. W. Campbell, Mazomanie, Wis.; Wm. Connolly, Cresco, Ia.; Isaac Dellar, Mineral Point, Wis.; W. W. Denny, Aurora, Ill.; W. W. Emerson, Aledo, Ill.

# LOOK AT THESE PRICES!

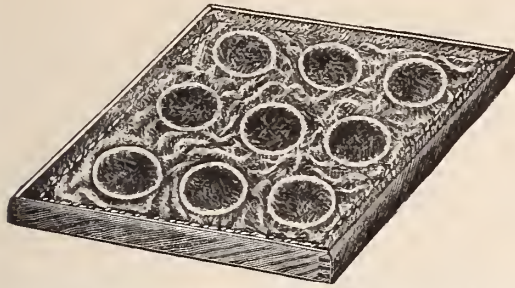

Show Case Trays with Solid Walnut Frames lined with Fine Red Silk Plush, with Old Gold Border, and made to stack one on top of the other. Size, 11 3/4 x 11 3/4.

- For Gents' Watches, each, . . . . . \$1.25
- For Ladies' Watches, each, . . . . . \$1.25
- For Rings, each . \$1.25. For Chains, each, . \$1.25
- For Charms, ea., \$1.25, for Card Jewelry, plain, ea., 80c.

Subject to the usual discount for cash.

## CHRISTMAS IS COMING.

Make your Stock Attractive and Fresh. It does not cost much and will add largely to your SALES.

## BENJ. ALLEN & Co.,

141 & 143 State St.,  
CHICAGO, ILL.



FINE PLUSH BOXES.

WATCHES, CLOCKS,  
DIAMONDS,  
SILVERWARE  
and JEWELRY.

- For Gents' Watches, per dozen, \$3.00
- For Ladies' Watches, per dozen, \$3.60
- For Rings, per dozen, . . . . . \$2.00
- For Ear Drops, per dozen, . . . . \$3.50
- For Six Tea Spoons, per dozen, \$9.00
- For Six Table Spoons, per dozen, \$15.00
- For Child's Set, per dozen, . . . . \$9.00
- For Six Coffee Spoons, per dozen, \$15.00
- For Sugar Shell, per dozen . \$9.00
- For Butter Knife, per dozen, \$9.00

Subject to the usual discount for cash.

### PARSONS & SCHOOL FOR WATCHMAKERS, PEORIA, ILL.

Send for Circular and Terms

PARSONS & CO.

THE PLANCHAMP & BECKER CO.  
Makers and Repairers of  
**WATCH CASES,**  
Gold and Silver Plating —  
— of Watch Cases a Specialty.  
UNEXCELLED FACILITIES.

63 and 65 East Washington St., Chicago.

**G.A. WEBSTER**  
42 & 44 Madison St., Chicago, Ill.  
**Manufacturer,**  
AND WESTERN AGENT FOR  
E. G. WEBSTER & SON, of Brooklyn, N. Y.  
A. F. TOWLE & SON CO. of Greenfield, Mass.

No jeweler or watch repairer should be without a copy of "WORKSHOP NOTES," a new and very useful book for the workshop. Send for circular containing a complete index of the book, and judge of its merits for yourself.

 **GENEVA  
OPTICAL Co.,  
CHICAGO.**  
CATALOGUES.

- PART 1—General Catalogue of Optical Goods.
- " 2—Microscopes and Accessories.
- " 3—Photographic Cameras, Stocks and Supplies.
- " 4—Thermometers, Barometers and Meteorological Instruments.

**PRESCRIPTION WORK** Made with Promptness and Accuracy.

**OCULISTS' or OPTICIANS' OUTFITS.** Trial Cases. Ophthalmoscopes. Lens Measures.

CORRESPONDENCE SOLICITED.

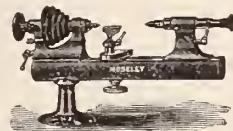

One of the best of the very best.

QUALITY IS THE STANDARD OF VALUE FOR WHICH WE COMPETE.

"THE MOSELEY."

"A Bread Winner" for the watchmaker. We furnish you good lathes and chucks, while the other fellow furnishes the wind.

MOSELEY & CO., Elgin, Ill.



No. 2 Moseley Wire Chuck has length, strength, accuracy.

## READ THE JEWELERS' CIRCULAR And keep informed on the latest Trade events. TRY A SIX MONTHS' SUBSCRIPTION OPTICIANS' SCHOOL.



If you want a GOOD ROOF over your head, come to our school. We want EARNEST STUDENTS, leave the rest to us, we do not want diploma hunters.

The Chicago Ophthalmic College and Hospital,

H. M. MARTIN M. D., PRESIDENT. 607 VAN BUREN ST., CHICAGO  
Being the oldest and most favorably known College of Theoretical and Applied Ophthalmic Optics in America, having more thoroughly qualified opticians in the field than all other so-called schools combined.



### The St. Louis Ophthalmic College and Hospital

A SCHOOL OF THEORETICAL AND APPLIED OPHTHALMIC OPTICS.

1655 SOUTH JEFFERSON AVENUE,

N. W. Corner Lafayette Avenue, - - - ST. LOUIS, MO.

For the Announcement and further information, address Ignatz Mayer, M. D., President.

## THE THING FOR A XMAS SELLER.



Finest Finish. Best Quadruple Plate. Any Style in Sterling Silver to Order.

INDIVIDUAL BUTTER AND SOUVENIR PLATES.

Any Name or Initial Engraved to order. Any Style. Any Quantity. Order Sample. Send for Illustrated Circular.

EXCLUSIVE CONTROL TO LIVE JEWELERS.

- 1/2 doz., Plain or Satin, Square or Round, in Plush and Satin Case, complete . . . . . \$3.00
- Or with Leatherette Satin Lined Case. . . . . 2.75
- 1/2 doz., Fancy or Initial Engraved Centers, in Plush and Satin Case . . . . . 3.63
- Leatherette Case . . . . . 3.38
- Without Plush Case, 75c. less; Leatherette, 50c. less. 6 per cent. off for Cash with Order.

Also Made in All Styles with Gold Border. FOR SURE WINNER ORDER QUICK.

O. E. BELL & CO., Mfgs. Cincinnati, O.

### San Francisco.

H. Judas is back from a two weeks' trip.

Rothschild & Hadenfeldt are renovating their offices.

Alfonse Hirsh was elected Supervisor of the 6th Ward.

Fred. Davis, who has returned from the north, reports that trade is looking up decidedly in Oregon and the northwest.

Louis Freund, of Max Freund & Co., New York, has been in town. Fred. Roth, of L. & M. Kahn & Co., New York, was also here.

Arthur Lord, a young jeweler from the east, who has been with Wells, Fargo & Co., has accepted a position with Vander-slice & Co.

In the new jewelry establishment in Oakland, of Lissner & Co., it is said that Cohn Bros., who run a store of their own in that city, are largely interested, as is also M. L. Levy, of this city.

Harry Nordman returned some few days ago from a very successful southern trip selling optical goods. He left again last week for northern California and Oregon. He will go as far as Portland.

Secretary Walter Camp, of the New Haven Clock Co., who is in California partly on business for the company and partly for coaching the Leland Stanford University eleven is receiving high en-

comiums from the leading San Francisco papers for his very successful handling of the football team.

H. L. Dodge and Wilfred Montague have filed their annual report as executors of the estate of Geo. C. Shreve, together with a petition for final distribution. They received from the other members of the firm of Geo. C. Shreve & Co. \$69,594 in cash, together with 950 shares of stock in the corporation, valued at \$95,000, all of which has been turned over to the widow.

### Pacific Coast Notes.

Chas. Martin, of Chicago, is registered at the Nadeau, Los Angeles, Cal.

Seth Thomas, of New York, is enjoying "the glorious climate" of Los Angeles.

Robert Norris has bought out J. G. Niemi, jeweler, 466 Commercial St., Astoria, Ore.

Travelers in the San Joaquin valley report trade exceptionally dull in that section.

F. W. Carter, San Luis Obispo, Cal., has moved into a fine corner store with larger and better quarters than of old.

The combined store of W. J. Pierce & Co., jewelers, and J. S. Glasscock, stationer, was opened in Pasadena, Cal., last week, with a concert.

J. K. Bayse, jeweler, Seattle, Wash., has entered into a combination, with a dry

goods and a grocery firm, whereby all will occupy one building in order to reduce rent and insurance.

Theo. W. Hansen, Portland, Ore., formally opened his new jewelry store at 271 Morrison St., Nov. 1. His establishment is said to be one of the most attractive in the northwest.

W. J. Pierce & Co., Pasadena, have fitted up a neat store in the Stowell Block. Mr. Pierce is from San Francisco where he has had twelve years' experience as a manufacturing jeweler.

Joseph Mayer, one of the defendants in the Rockford Watch Co., *vs.* Simon Rumpf *et al.*, of Seattle, Wash., has filed his notice of appeal from the order of the court refusing to dissolve the temporary restraining order granted against him.

John Doe, who recently attempted to burglarize N. G. Ingals' jewelry store, Castle Rock, Wash., tried to play the insanity dodge and succeeded in fooling nearly every one except the judge and jury. He was sentenced to three years in the penitentiary.

A number of new brownies have been added to the handsome line of sterling silver enameled fancy figures shown by R. L. Griffith & Son, Providence, R. I. They are offered at a remarkably low price. Does your stock include the "Golconda Gem" mounted exclusively by this house?

# NOW IS THE TIME . . .

To look over your old style and unsalable jewelry, old plated jewelry, filings, sweeps, etc  
You want to put your stock in good shape for the holidays. The question is:

"Where shall I send my old gold and silver?"

Remember, that we pay 4c. per kt. for Gold and Highest Market

## Prices for Old Silver.

There is a well known maxim that "Experience makes perfect." To accurately test and value a lot of old gold, etc., the requisite experience is absolutely necessary. Being the largest buyers of old gold and silver in the country, and having the exclusive patronage of the majority of the jewelers in the United States and Canada, we can guarantee to the trade accuracy in valuation and

**PROMPT AND HONEST RETURNS.**

 **OUR PLAN**

Immediately upon receipt of shipment we will remit by cash or draft (as desired). If our offer should not prove satisfactory, we will return consignment in exactly same condition as received, and pay all charges. By this arrangement you are absolutely safe, as it is no sale unless our offer should prove satisfactory, and you run no more chances than if you were disposing of same right over your counter.

**GOLDSMITH BROS.,**

Mention the Jewelers' Circular.

Gold, Silver and Platinm Refiners and Assayers,

**FREE**—Send for our **LITTLE BOOK** giving pointers on preparing acids, testing and buying gold, etc., mailed free on application.

63 & 65 Washington St., Chicgao, Ill.

**Detroit.**

Albert Schaub last week lost his wife by death.

C. A. Waterman, representing the Pair-point Mfg. Co., visited the trade here last week.

M. M. Dwilliard, with the United States Optical Co., has returned from a month's trip in the east.

Word was received here last week of the death of Mrs. E. J. Brown, wife of the jeweler in Reading, Mich.

Bert Born last week opened a new jewelry establishment in Otsego, Mich. He purchased a stock in Chicago.

J. J. Newell, for many years a jeweler in Adrian, Mich., died last week in Philadelphia. He was in business in Adrian for 34 years. He was 76 years old.

P. A. Walker, of Berrien Springs, Mich., has sold out his jewelry business to Frank Wiley, who will continue it. Mr. Walker will go on the road for an optical firm.

Fire last week broke out in the basement of Burt & Moody's jewelry store, Battle Creek, Mich. The whole cellar and part of the first floor were burned. The stock was considerably damaged by smoke and water and the loss will approximate \$1,000. Spontaneous combustion is said to have been the cause.

R. J. F. Roehm & Sons, to whom a draft of a silver stamping bill was sent by THE CIRCULAR, as mentioned in a recent issue of this journal, during the last week circulated a petition among the jewelers, which has been signed by nearly every one in the city, asking them to endorse the bill which will be presented to the Legislature this Winter in their behalf. The lawmakers will be requested to make it an offense for any manufacturer or dealer to stamp silverware with the word "sterling" when the facts will not warrant it. The consensus of opinion here is that it is an excellent idea.

Business with the jobbers brightened up some last week after the election. It is ahead of that of last year at this time. Among the Michigan country jewelers who were in the city last week were: H. Loss, Wayne; J. A. Burtis, Ypsilanti; C. E. Montford, Utica; John O. T. Edington, Orion; Mr. Merritt, Northville; C. G. Draper, Plymouth; W. T. Blashill, Oxford; John Webber, Wayne; R. E. Brackett, Lansing; Fred. Grimm, Mt. Clemens; T. Smith, Trenton, and S. A. Cleveland, Utica.

**Louisville.**

R. H. Clark, Shelbyville, Ky., was here last week.

Geo. H. Casperke, Brandenburg, Ky., was in the city last week.

Wm. C. Kendrick is in New York purchasing holiday goods.

Joseph G. Childs, with Buschemeyer & Seng, was married last week to a Portland belle.

Wm. M. Schmidt, who was until last week watchmaker for Mrs. Joseph Kern, is now with Buschemeyer & Seng.

Rodgers & Pottinger, 4th and Market Sts., are soon to move to 4th Ave., next door to Wm. Kendrick's Sons.

Mr. and Mrs. Geo. Wolf are at the bedside of their daughter, Mrs. Henry Lubber, who is critically ill in Quincy, Ill.

C. J. Rauch, traveling salesman for Geo. H. Kettmann & Co., was taken so ill that he was compelled to take to his bed.

Leonard Huber, who has been confined to his bed from a fractured knee cap the past three weeks, is able to be out on crutches.

B. F. Liker, watchmaker for Wm. Kendrick's Sons, will shortly place a new cylinder punch, invented by himself, on the market.

Business with the manufacturers is exceedingly good. Buschemeyer & Seng were compelled to work two nights last week. A great rush is reported in silverware by Fourth Ave. jewelers.

**Indianapolis.**

W. T. Marcy has returned from a purchasing trip to New York.

W. A. Winn, Newman, Ill., was in the city last week buying goods.

Elkhart, Ind., has a new jewelry store with Albert Allen as proprietor.

C. D. Tilson, Greengburg, Ind., has completed a handsome new store room.

D. F. Greene has opened a new jewelry store in Fort Wayne, Ind. Mr. Greene was formerly with R. S. Patterson & Son, Port Huron, Ind.

J. W. Vaughn, a graduate of the Chicago Ophthalmic College, has taken a position with W. J. Eisele. Mr. Vaughn formerly carried on the optical business in the room now occupied by Moses' Optical Institute, on East Market St.

E. R. Biggs, Goshen, Ind., has sold his old established jewelry business to J. H. Ralston and G. B. Kessler, who will continue it under the firm name of Ralston & Kessler. Mr. Ralston was formerly Mr. Biggs' assistant, and Mr. Kessler has held a position in Chicago.

An advertisement of the New York Dry Goods Store offering gold filled cases and Waltham movements "at prices to cause a sensation" aroused the Retail Jewelers' Association to take prompt and vigorous measures to ascertain from what source the dry goods houses can buy such goods. The local jobbers have heartily co-operated with the retail dealers.

The A. C. Smith Watch Co. discontinued the "complete watch" branch of their business and make a special offer to close it out. This is a rare chance to buy fine watches at the price of ordinary makes.



Our Salesman  
**Watch**  
 the results of  
 Our  
**Salesman**  
 640 Page Catalogue, 1895,  
**Open**  
 On your Show Case.

That will prove his value to you. He does not draw any salary but will double your sales. Open on your show case, as inquisitive people can't help but buy. Bottom prices and special drives are his strongest arguments why you should buy of him.

Send for our 640 Page Illustrated Catalogue if you haven't received it. It's a money maker for you.

OUR NAME DON'T APPEAR IN IT.

**F. M. Sproehne & Co.**

103 STATE ST., CHICAGO,

Wholesale Jewelers.

**YOU'LL SAVE MONEY**

by ordering your Holiday Stock from it.

**Cincinnati.**

B. Strang, of Jonas, Dorst & Co., returned last week to stock up and go out again.

Jos. Mehmert returned from his extended trip and has gone up through Ohio on a short trip.

Henry Hahn & Co. are sending out watch and ring circulars offering inducements to the trade.

A. G. Schwab has returned from a successful trip, and says he is confident of a good holiday trade.

D. Schroder & Co. are receiving daily inquiries for their catalogue, the edition of which is nearly exhausted.

Thomas Lovell has removed his street clock to his new place of business on Race St. It is the only clock on the street.

Jos. Gosling, of Jos. Noterman & Co., is still in Colorado. His wife returns this week, but he will remain until he has thoroughly recovered his health.

The late robbery of the Wells, Fargo Express, in Texas, caught O. E. Bell & Co., with a box of watches, etc., shipped to their traveling salesman at Fort Worth. The goods have not yet been recovered.

Charles Stern has been seriously ill for the past ten days with stomach trouble. He was removed to the Jewish Hospital to receive the best professional services. His travelers were summoned home last week, as he was thought to be in a critical condition, but he is now resting easier and the physician gives hope of his recovery.

E. J. Morris, manager of the bric-à-brac and art department of the Duhme Co., goes to New York this week to buy new goods for the holiday trade. Fred Cramer, who takes care of the silver department, made up some elegant lots for weddings the past week. Theodore Niehaus has distinguished himself the past week in win-

dow dressing. The Duhme Co.'s windows have been the attraction for days.

E. & J. Swigart, importers and jobbers of tools and materials, are as busy as they can be. Their trade in boxes and trays has been phenomenal this season. Eugene Swigart and Messrs. Solar and Francis are all on the road reporting splendid business.

O. E. Bell & Co.'s silver plate offers are meeting with success. The individual butters in the plush cases are a surprise to the trade for the money. The firm are now getting out other novelties.

**Rockford.**

C. B. Wilbur has opened a new jewelry store in Winnebago.

E. B. Kizer, of Chicago, has opened a jewelry store in Pecatonica.

The Union Nickel and Plating Co., at Freeport, have moved into new quarters and are doing a flourishing business. A meeting will be held soon at which the stockholders will vote on an increase of the capital stock.

Secretary G. B. Kelley, of the Rockford Silver Plate Co., has just obtained a patent on a new knife burnisher. Mr. Kelley, in the interest of the company, has spent much money the past seven years trying to perfect machines for rapid burnishing and at last his efforts have been crowned with success. About a year ago he patented a burnisher which puts the burnish on 18 blades at once. His new contrivance is probably the quickest working machine of the kind in the country. Two girls with three machines can burnish 150 dozen knives in a day and do better work than formerly.

Seth Thomas Clock Co., have completed a contract for a tow clock for Marinette, Wis., to be glass dals, hour strike, with large bell.

**Meeting of the Chicago Engravers' Association.**

CHICAGO, Ill., Nov. 17.—The meeting of the Chicago Engravers' Association, postponed from Nov. 7, was held at the rooms of the Chicago Jewelers' Association, Wednesday, and the schedule of rates, constitution and by-laws informally discussed. The meeting adjourned to meet Monday, Nov. 19, at the same place. The following engravers and manufacturing jewelers are members of the new association :

Engravers:—W. H. White, Jno. B. Wiggins, Chas. A. Norton, Martin B. Stetcher, L. Hadorn & Co., Herman Bischoff, C. H. E. Boughton, Louis Kasten, Richard H. Kandler, H. R. Gentsch, L. G. Boone and C. B. Smith.

Manufacturing Jewelers:—Juergens & Andersen Co., G. W. Hook, Spies & Co., Robt. M. Beygeh & Co., J. Milhening, R. M. Johnson, Wendell & Co., C. H. Bisson Co., and De Lacy Mfg. Co.

"Organized effort on the part of these leading firms," says secretary W. H. White, of the Association, "will result in benefit to all."

**A Swindling Scheme Being Worked in Michigan.**

DETROIT, Mich., Nov. 16.—The officers of this city have been notified that a scheme is being worked in Michigan in which Chicago jewelers are the sufferers. Five different consignments of jewelry from as many houses in Chicago were recently sent to the address of William G. Boyd, jeweler, Waldron. As Mr. Boyd never ordered the goods it is thought that the same game played on the express office, at Alfordton, O., was intended at the Michigan town. For some reason no attempt was made to rob the office.

**THE WADSWORTH WATCH CASE CO.**



774.

General Offices,  
NEWPORT, KY.



793.

NEW 12 SIZE  
TO FIT ALL 6S. P. S. MOVEMENTS.

Cases.

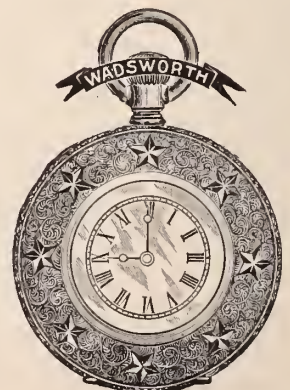

802.

Chicago Office,  
COLUMBUS BUILDING.



# H. M. SMITH & CO., MANUFACTURERS,



83 NASSAU STREET, - - NEW YORK CITY.  
New Catalogue Just Issued.

## MATHEY BROS., MATHEZ & CO.

21 & 23 MAIDEN LANE, N. Y.  
BRASSUS, SWITZERLAND.

MANUFACTURERS OF  
THE SMALLEST,  
THE THINNEST,  
THE NEATEST AND  
THE BEST

**SPLITS.**

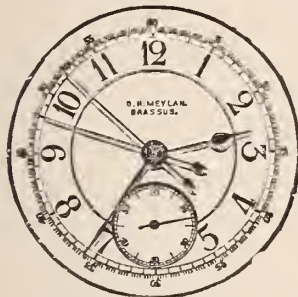

10 Size.



13 Size.

SOLE AGENTS FOR

**JAUQUES • LECOULTRE • RAZORS.**

**\$3.00**

**FORMERLY**

**\$6.00**

Ivory and  
Enamel  
Miniatures

Best  
Workmanship.



Original  
Inventor and  
Patentee of  
**Miniatures**

—OR—  
**Gold and  
Silver.**

PATENTED  
November 12, 1889

**LEON FAVRE, 107 EAST 26TH STREET,  
NEW YORK.**

## MUSICAL BOXES

FACTORY AT AUBERSON, SWITZERLAND.  
ESTABLISHED 1828.

**E. L. CUENDET, 21 John Street, New York City.**

Send our New Illustrated Catalogue for 1894, containing Full Particulars and Price Lists.

SPECIAL SALESMAN OF

**WATCHES, DIAMONDS,**

**Bric-a-Brac**

and Art Goods

FOR

**Established Jewelers.**

WRITE FOR PARTICULARS.

Communications Strictly Con-  
fidential.

References given in all parts of the  
United States from Retail-  
ers and Jobbers.

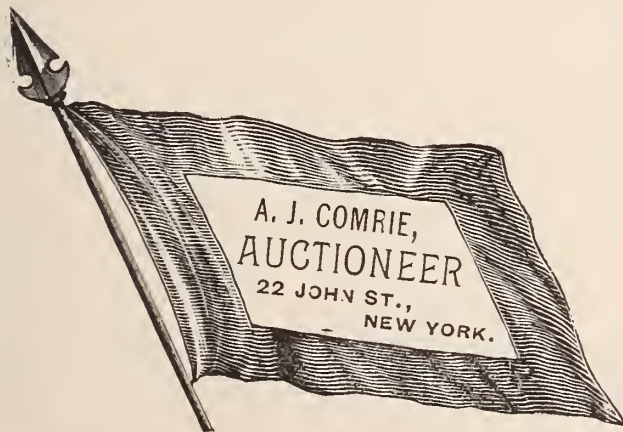

## A RICH COMBINATION.



Cut Glass Bowl on Artistic Solid Cast Brass Base. Fin-  
ished in Matt and Burnished Gold.

The Combination of Gold and Cut Glass  
shown above was a most daring one. Its  
INSTANT and INCREASING SUCCESS is a  
proof that the trade appreciates it as a  
SELLER. Write us at once for full partic-  
ulars and prices if you are not carrying it.

A Specially Good Thing for Jewelers.

**T. B. CLARK & CO., Inc.,**

860 Broadway, N. Y.,

Factories, HONESDALE, PA.

N. E. Cor. 17th St. & Broadway

**THEODORE C. STEINHAUS,**

— MANUFACTURER OF —

**Fine Cases and Trays**

For JEWELRY, SILVERWARE, &c.  
SAMPLE CASES AND TRAYS FOR TRAVELERS,  
Fancy Hard Wood Chests for Silverware, &c.  
Linings, Cushions, Mounting, etc., for Sil-  
ver Novelties.

10 MAIDEN LANE, NEW YORK.

**Fountain Pen 14 Kt. Solid Gold Nib**

**\$7.50**

Net Cash  
DOZ. with Order.



Elegant Plush Lined Box FREE. Every Pen Warranted. Send for Catalogue.

**DIAMOND POINT PEN COMPANY, 7 Astor House (Broadway), New York.**

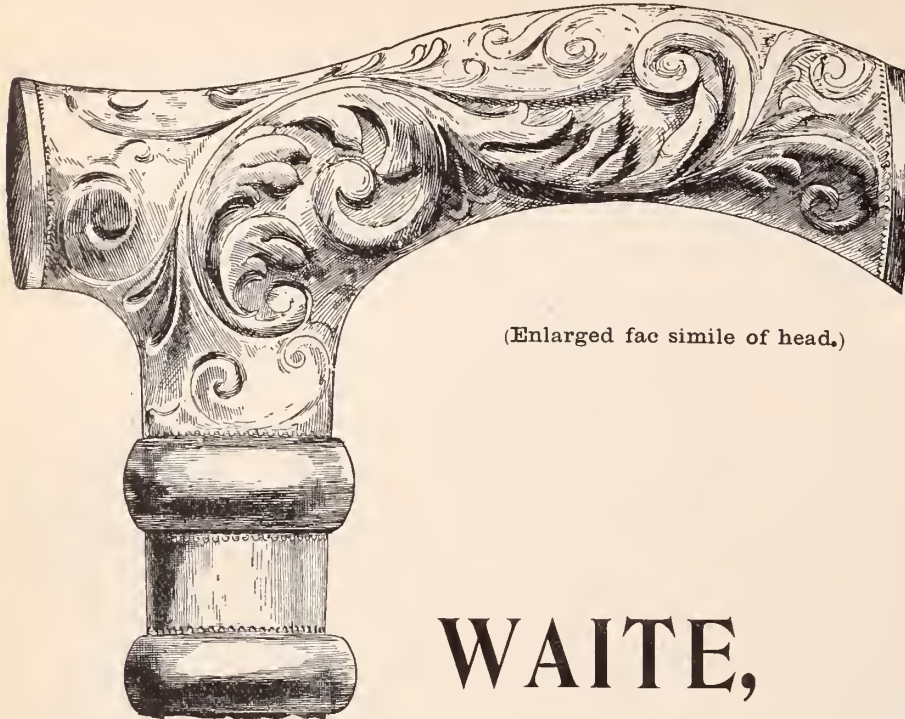

(Enlarged fac simile of head.)

OUR  
CANE  
Stick  
And  
Lapel  
Pins.

PATENTED  
OCT. 23, 1894  
ARE  
THE  
PROPER  
THING.

HEADS  
ARE OF  
SOLID  
GOLD OR  
STERLING  
SILVER,

Artistically  
CHASED.  
STICKS  
ARE  
ENAMELED  
TO  
REPRESENT  
NATURAL  
WOODS.

THEY SELL AT  
SIGHT.

# WAITE, THRESHER COMPANY, Providence, R. I.

## Connecticut.

C. C. Carroll, the Wallingford jeweler, is his new pleasant quarters in Judd's block.

Malcom Cameron, of Hartford, is to open a jewelry store in Cadoret's block, New Hartford.

Philip Stevens, Bristol, has leased a portion of a store and will shortly open a jewelry establishment.

The annual Fall opening of Henry Kohn & Sons, jewelers, of Hartford, occurred Nov. 15th, 16th and 17th.

President Watson J. Miller, of the Derby Silver Co., and wife left Nov. 12th on a trip to New York and other points.

New roads are to be built by the town of Glastonbury for the accommodation of the new silver company in that town.

The death occurred Nov. 12 of William Stuart Williams, one of the officers of the Williams Bros. Mfg. Co., Naubuc.

Jeweler and optician L. V. B. Hubbard, of Shelton, is conducting B. S. Hall's jewelry store in Shelton, during the latter's absence.

Salesman R. H. Miles returned Nov. 13th, to Meriden from a business trip to Columbus, O., and Indianapolis, Ind., for the Meriden Britannia Co.

The Westfield Plate Co., Thompsonville, are well supplied with orders, and have increased the working time of the employes to 60 hours per week.

W. E. Lamb, who has had a jewelry repairing room in Manchester, has gone to Wilmington, N. C., where he and his wife will spend the Winter.

The Wallingford Telephone Exchange has elected C. H. Tibbits, of Simpson, Hall, Miller & Co., vice-president, and Col. W. J. Leavenworth, a member of the executive committee.

Conrad Wissel, of Brooklyn, has again assumed a position with jeweler A. W. Austin, South Norwalk. Wissel was employed by Austin some ten years ago and left his employ to start a place for himself in Brooklyn.

The Simpson Nickel and Hall & Elton companies, Wallingford, are running their works 12 hours a day. Some departments are working over time. Simpson, Hall, Miller & Co.'s works are running evenings since election day.

C. B. Rogers, of C. Rogers & Bros., Meriden, Samuel Dodd, also of Meriden's silver plate interest, and George Rockwell, were elected members of the board of directors of the Meriden, Waterbury & Connecticut River Railroad Co., at the annual meeting just held.

Alderman William H. Watrous, the Republican representative-elect from Hartford to the General Assembly, said last week to a reporter: "I expect a general revival of business. This hand to mouth method that we have been obliged to adopt in our commercial relations will end and once more manufacturers will lay out work for the future. There is no danger of any more tariff tinkering by Congress this Winter. The lesson is too severe."

**Scarabæus Jewelry.**

**I**N an artistic pamphlet Carter, Sloan & Co., New York, illustrate a number of specimens of their Scarabæus and Wing jewelry which is a notable novelty in the lines of jewelry produced for the holiday trade. Scarabs have for many years been employed in jewelry to a greater or less de-

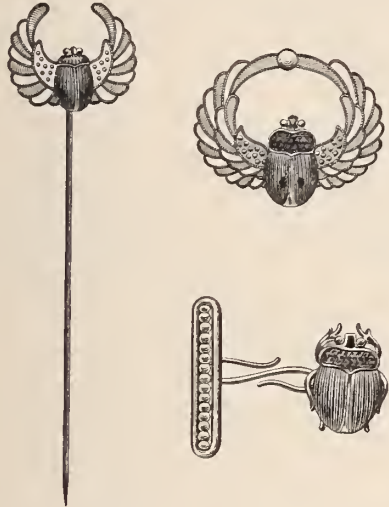

gree, but in the present instance they are seen in all the prevailing forms of jewelry, in distinct yet varied and attractive styles, and will doubtless attain a large measure of success.

The pamphlet contains the following historical sketch of the scarabæus :

“The Scarabæus, or Sacred Beetle of Egypt, is the most distinguished insect in history. A recent writer says of it, that it was the symbol of elevated religious ideas, such as a future life, a resurrection, and of reward and punishment hereafter. The

Egyptians believed the heart to be the seat of the intellect and the source of life, and when it was removed in process of mummification, a model of the scarabæus was put in its place.

It was supposed that the scarabæus was exclusively of the male sex, self-begotten, and therefore represented the Creator of the world.

As the representative of the Sun-god, it was worshiped by the other deities.

“The models of the scarabæus, use by the Egyptians, were usually made of such stones as green basalt, granite, lapis lazuli, jasper, cornelian, amethyst, sardonyx, agate and onyx ; many of them were very artistic.

“It was used as a religious symbol, a charm, a medal struck in honor of some event, and a coin. The Egyptians were troubled with no coinage question, for a sacred image on any piece of stone made it money. The scarabæus was worn as a charm by soldiers to increase their bravery, and by women as an ornament. It was a favorite talisman of the Romans, and has been extensively used in decorations at various times throughout the succeeding centuries.”

The great advances achieved by modern research in Egyptology have caused the scarabæus to be sought after, at the present time, especially in articles of personal adornment, and the effects of the scarabæus alone, or with the outstretched wings of the sphinx, in combinations of the precious metals, or in the varied and brilliant hues of enamel, combine to render these jewels peculiarly attractive to persons of refinement and cultivated taste.



bæus alone, or with the outstretched wings of the sphinx, in combinations of the precious metals, or in the varied and brilliant hues of enamel, combine to render these jewels peculiarly attractive to persons of refinement and cultivated taste.

SILVER AND GOLD PLATE

**PHOTO FRAMES and CALENDARS.**  
COLLEGE FOOTBALL FRAMES !

Harvard, Yale, Princeton, Columbia, Cornell, University of Pennsylvania, etc.



**L. H. COHEN,**   
...Maker...  
143 & 145 ELM ST., NEW YORK.

**SOMETHING NEW !**

**Interchangeable Initial Watches.**



We have placed on the market a line of “Charmilles” watches cased in steel, black oxydized with GOLD INITIALS in relief. These initials are interchangeable with the backs ; are 10 karat gold, cost but little extra, and make

**A VERY ATTRACTIVE WATCH.**

INITIAL watches appeal to public sentiment and taste. The advantages of INTERCHANGEABLE Initial Watches at LOW PRICES will be appreciated by all.

Ask Your Jobber For Them.

A. C. SMITH WATCH CO., - 177 Broadway, New York.

### News Gleanings.

W. Worthen has opened a jewelry store in Nauvoo, Ill.

W. J. Hanks will go into the jewelry business in Eldora, Ia.

Alfred Bolsta has opened a jewelry business in Ortonville, Minn.

E. B. Born, of Allegan, Mich., has opened a jewelry store in Otsego, Mich.

George H. Frees will open a new jewelry store at 248 N. 9th St., Reading, Pa.

Josiah B. Dennis will shortly open a stock of jewelry, etc., in Williamsport, Ind.

The business of Jeweler Chase, Caledonia, N. Y., was damaged by fire last week.

Geo. Peters, Tarkio, Mo., has sold his jewelry establishment to C. F. Jennings, of Iowa.

Frank Mayr, South Bend, Ind., is now located in his new store, 121 W. Washington St.

Frank Downey, jeweler, Chenoa, Ill., has removed to the location formerly of jeweler M. W. Jenks.

Joseph Leibson opened a new jewelry store Nov. 13th at 128 E. Market St., Wilkesbarre, Pa.,

Jeweler Offenhaeuser, Granville, N. Y., has removed to his new quarters in the Norton block.

Jeweler Smith Seeley, Bristol, Conn., will occupy the store corner of Main and Center Sts., Wallingford.

B. W. Richardson, Clayton, Ill., announces his intention of retiring from the jewelry business in that town.

Karl G. Ramberg's store, Rush City, Minn., was burglarized a fortnight ago and about \$40 in coin and jewelry secured.

F. Overstreet, Farmer City, Ill., has sold his jewelry stock to Charles Stiller, of Le-mont, formerly of Lexington and Bloomington.

Charles Gross, long with W. F. Robie, jeweler, Cuba, N. Y., will return to his home in Buffalo, where he will go into business for himself.

F. Roland, engraver and manufacturing jeweler, has opened business in connection with Joseph Loeb, jeweler and watchmaker, 710½ Penn St., Reading, Pa.

The residence of George W. Brown, jeweler, Cheyenne, Wyo., was damaged by fire recently. The blaze was started by the explosion of a gasoline stove.

A change has been made in the management of A. C. Thorpe's jewelry store, Wahpeton, N. Dak. Mr. Blinn has retired, and is succeeded by E. E. Bassett, of Polo, Ill.

A new jewelry store, to be managed by P. H. Stevens, will soon be opened at 7 N. Main St., Bristol, Conn. The firm name will be P. H. Stevens & Co. Mr. Stevens was formerly watch repairer with Lee Roberts, of that town.

The jewelry business of Charles K. Morgan, deceased, Titusville, Fla., has been sold out to Anthony Bros., and under that name will in future be run at the same stand.

The tray that contained the rings stolen from jeweler T. S. Adle's store, Norristown, Pa., was found where Patrick Mitchell, the thief, said it was, near the lower bridge, in Bridgeport. One ring was found with the tray.

In the Circuit Court, at Rochester, N. Y., Nov. 13th the jury case of the Ettenheimer

Jewelry Co., brought in a verdict of \$130.30 for the plaintiffs against Elijah Boyer. It was the third trial of the case and the costs amount to \$500, a total of \$630.30 on a note originally for \$100.

C. Preusser & Co., Milwaukee, Wis., on Nov. 18th celebrated the semi-centennial of their existence. For a half century the Preusser Jewelry Co. have been one of the substantial and progressive business institutions of the city and their golden anniversary was pleasantly observed.

Last Friday evening at 6 o'clock the employees of the Stevens Silver Co., Portland, Me., were called into the office and surprised to find an elegant spread, tendered to them by W. A. Cates and S. H. Sleeper, respectively the president and treasurer of the company. The firm have been working 13 hours a day for the past six weeks and the banquet was given in appreciation of the services rendered by the employees.

One morning at 1 o'clock recently, F. B. Eberhard, jeweler, 223 Hamilton St., Allentown, Pa., was awakened by the ringing of the burglar alarm bell in his sleeping room in the rear of the building. He jumped out of bed and seizing his revolver fired it out of the window and then proceeded downstairs. Wm. Krause, a neighbor, also heard the ringing of the burglar alarm and at the same time heard some one running rapidly away. He went down stairs and joined Mr. Eberhard. The two made a thorough examination of the premises, but nothing amiss was discovered. No marks on the front door were visible. The alarm is so arranged that the slightest pressure on the door sets it going.

The store of Judson Newing, 138 Court St., Binghamton, N. Y., was recently burglarized of goods valued at about \$200. Investigation showed that some one had taken a stone weighing about three pounds, wrapped it in a white handkerchief, and had thrown it against the lower right hand corner of the pane. By the aid of a stick the thief had pulled the jewelry in the window to the hole so that he might reach it from the outside. The stick, the handkerchief and stone were inside.

### Lancaster, Pa.

Edw. R. Zahm, a well known local jeweler, has connected himself with the jewelry store of Jack Straub.

Miller W. Fraim, proprietor of the Lancaster Silver Plating Co., died Wednesday morning at the Stevens' House, where he had lived for some years. Mr. Fraim was stricken with paralysis on Monday evening. Deceased was 35 years old and unmarried. He was a man of remarkable energy and fine business abilities. About five years ago, in partnership with A. H. Rosenstein, he established the Lancaster Silver Plating Co., and they met with remarkable success. Their principal product was ornamental umbrella handles. About six months ago, Mr. Rosenstein retired from the firm and since then Mr. Fraim conducted it himself.

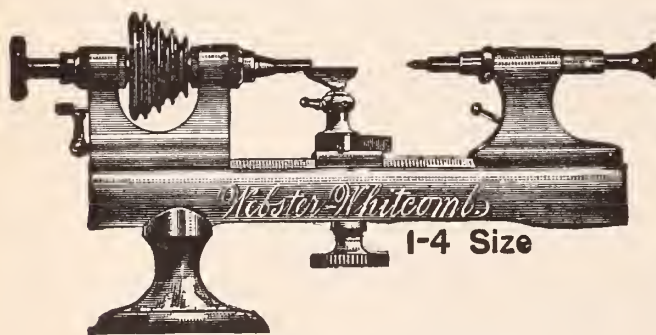

**STRONGEST GUARANTEES.**

**Quality  
Maintained.**

**Prices to  
Suit the Times.**

**Ask for our New  
Prices and  
Terms for 1894.**

**American Watch Tool Company,**

**Chymistry Dist., Waltham, Mass.. Stoney Batter Works.**

**2 MEDALS AWARDED**  
 Wm. K. POTTER,  
 TORTOISE SHELL WORKS PROV. R. I.  
 AT  
 WORLD'S  
 FAIR,  
 1893.  
 TRADE MARK  
 Providence Shell Works, Providence, R. I.  
 Correspondence Invited

**FERD. FUCHS & BROS.**  
**SILVERSMITHS,**  
 MAKERS OF STERLING SILVERWARE,  
 808-810 Greenwich St., New York.

# RUDOLSTADT

HIGHEST  
AWARD  
WORLD'S  
COLUMBIAN  
EXPOSITION.



## ART POTTERY.

CONTAINS all the elements re-  
quired as to designs, deco-  
rations and workmanship, in a high  
grade of Art Goods adapted to the  
Jewelry Trade, and yields a larger  
margin of profit than any other  
class of Pottery.

**L. Straus & Sons,**

SOLE AGENTS,  
42-44-46-48 Warren Street,  
116 Chambers Street,  
NEW YORK.



**..THE LATEST..**  
**Sterling Silver Novelty,**  
**CIGAR CUTTER**  
**AND KEY RING COMBINED.**

(Patent applied for.)

WITH OR WITHOUT CHAIN.

MADE ONLY BY

**ENOS RICHARDSON & CO.,**

23 Maiden Lane, New York.

## CAMPBELL-METCALF SILVER CO.

FACTORY:  
STEWART ST.,  
PROV., R. I.

N. Y. OFFICE:  
2 MAIDEN LANE.

SAN FRANCISCO:  
112 KEARNY ST.

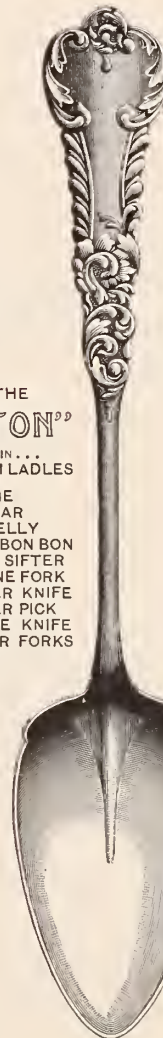

THE  
"ETON"  
... IN ...  
CREAM LADLES  
ORANGE  
SUGAR  
JELLY  
BON BON  
SUGAR SIFTER  
SARDINE FORK  
BUTTER KNIFE  
BUTTER PICK  
CHEESE KNIFE  
OYSTER FORKS  
ETC.



OUR  
"ETON"  
AND  
"STUART"  
PATTERNS  
ARE IMMENSELY  
POPULAR  
AND SELL AT SIGHT  
WRITE DIRECT  
TO FACTORY FOR  
SAMPLES  
AND PRICES.

## FANCY

.. IN ..

SCARF PINS

AND LINKS.



## FIGURES

STERLING SILVER,

Enameled in Colors.

Dudes, Chinamen, Policemen, Sailors, Orators, Cadets, and all other Shapes Made.

SEND FOR SAMPLES.

QUICK SELLERS.

If your Stock does not include our **GOLCONDA GEM** Line you are losing sales. This Stone is Mounted in Studs, Scarf Pins, etc., in Solid Gold and Plate.

If your jobber doesn't keep these goods write us and we will send you the address of a jobber in your vicinity who does. Every card bears the words "THE GOI CONDA GEM, Reg'd." all others said to be "equally as good" are spurious. Bear this fact in mind

**R. L. GRIFFITH & SON, = PROVIDENCE, R. I.**

## HILDRETH M'F'G CO.,

53 MAIDEN LANE, NEW YORK.



Standard Quality. Standard Prices. Finest Finish.

**Plain Solid Gold Rings.**



# FERDINAND BING & Co.,

106 GRAND ST., N. Y.

NEW DESIGNS IN

China Clocks and Gilt Bronze Sets, Fine Painted  
 Dresden Goods in Vases, Cups and Saucers, and Plates;  
 Cararra Marble Statuary, French Cabinets and other  
 Fancy Furniture.



## "BROWNIES"

Have become very popular through the medium of the "Ladies' Home Journal" and the "St. Nicholas." The following illustration is a reproduction of a Souvenir Coffee Spoon designed by a Louisville lady and controlled by



WM. KENDRICK'S SONS, Jewelers,

336 4th Avenue, Louisville, Ky.

PRICES: Coffee Spoon, Plain, \$2.00; Gilt Bowl, \$2.25; all Gilt, \$2.50. Discount to Jewelry Trade. SPECIAL: Upon receipt of \$1.50 Spoon will be sent as sample.



**Larter, Elcox & Co.**  
 Manufacturers of Fine Gold Jewelry  
 21 & 23 Maiden Lane, New York.

The Attention of the Trade is called to Our Line of . . .

### GENTLEMEN'S RINGS AND SEALS,

with Intaglios, in Jade, Jasper and Carnelian. These goods are exceedingly desirable for this season's trade.

ALSO our full line of Misses' and Children's Rings finished in Roman.

See also our large line of Low Priced Link Buttons, in Solid Gold.

Our Spring Back Studs, improved in construction, are now as near perfect as can be, and never so complete in variety of patterns.



BUY ONLY THE L. E. & CO. STUD.

SELECTION OF STUDS SENT ON APPLICATION.

CHASED, No. 1617, \$4.50 PER DOZ.  
 PLAIN, No. 1614, \$3.75 PER DOZ.

◆◆ OUR KEY RINGS ◆◆

are the best in the market for the price. They are quick sellers and make good card prizes. Our Czarinas, Collar Buckles and Belts are just as popular as ever. Shell Hair Pins and Side Combs with sterling trimmings in all styles. Watch Pockets and all the latest in sterling silver.

**CODDING BROS & HEILBORN,**  
 NORTH ATTLEBORO, MASS.

N Y W YORK OFFICE,  
 C. A. Vanderbilt, - 178 Broadway.

CHICAGO OFFICE,  
 F. A. Buck, - 103 State Street.

"SECURITY PIN GUARD."  
 Can be Used on Scarf or Ladies' Pin.



85c. Dozen Gold, \$6.00 } Doz  
 Net Cash. Silver, 3.00 } Net Cash  
 DISCOUNT TO JOBBERS.  
 Security Mfg. Co., 7 Astor House, B'way, N. Y.



### Porcelain Decorations in Art Furniture.

HIGH art furniture is essentially a production that jewelers should supply to a discriminating public. It is in line with the fine ceramics, rich cut glass, and other art products. Such wares as are seen in the New York showrooms of Geo. W. Smith & Co., at 818 Broadway, are especially adapted to the jewelry and art trades. The illustration here depicts the latest design in

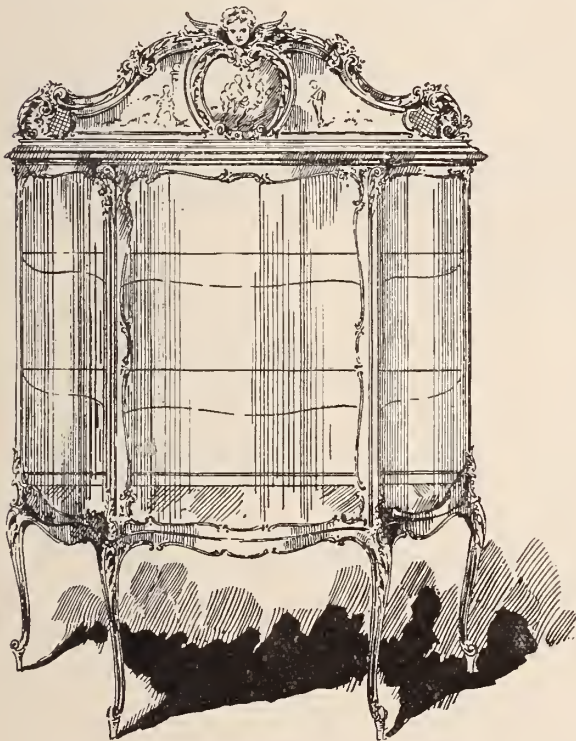

CABINET WITH PORCELAIN TOP.

cabinets, being entirely in gilt, with the exception of the panels at the top which are of fine porcelain painted with as true art as is applied to the finest of foreign ceramics. This paneling is American work, and with the elegant cabinet work of Geo. W. Smith & Co. produces an article that is the consummation of industrial art. Such combinations are a feature of the season's productions of Geo. W. Smith & Co.

### A Craze For Pottery.

POTTERY collecting is reviving, and is just now pushing itself forward. Heretofore women have been satisfied to express a sort of learned admiration for Sèvres and Dresden and Royal Worcester ware much as the average visitor in a foreign picture gallery does on the paintings which are distinguished by double stars in Baedeker's guide books. But things have changed.

The present pretty custom of giving to a young lady whose engagement has been announced a dainty cup and saucer may have started the craze, or it may be the result of it; but whatever its origin, the pottery fad has signalled its coming, and the real *fin-de-siècle* woman will know not only the ear-marks of the various kinds of pottery, but something of their history and of their real value. It will be a sorry day for some of the dealers in artistic pottery when their customers no longer admire their goods according to the price marks, for the careless habit some of them have fallen into of annexing an extra cipher to the price of a 10*l.* vase, for example, will have to be corrected. However, the honest dealer will get the benefit.

There is a good deal of mystery and a good deal of history associated with the evolution of artistic pottery. The connoisseur in the art can interpret into history scores of cabalistic signs that, if noticed

at all, are to the untutored as unintelligible as Phœnician hieroglyphics. An ancient Greek vase, for example, pictures the manner in which the Athenians played ball. The decoration illustrates the figures and attitudes of the players, and an inscription represents one of them shouting to another in the vernacular of the day, "Chresan moi tan sphalan," "I throw me the ball." Other vases bear the inscription in old

Attic "I am one of the prizes from Athens." An amphora found not many years ago at Orvieto is inscribed in early Attic characters, "Two obols and you have me."

The origin of vase painting and of ceramic decoration generally is lost in the oblivion of antiquity, but the modern development began with the eighteenth century. In 1700 a bright young chemist named Frederick Boettger, a native of Saxony, fled to Dresden under the accusation of practising magic arts. He was there taken under the protection of Augustus II., Elector of Saxony, who believed that the young chemist knew the secret of making gold. Boettger denied this, but the Elector set him at work with his own alchemist, hoping that the two together would discover the philosopher's stone. For nine years Boettger worked for his royal patron, part of the time at Dresden and part at the Castle of Meissen, carefully guarded and kept in seclusion almost like a prisoner, not only that his discoveries might remain a secret, but that he might not escape from the country. During all this time he produced only stoneware, though of a finer and harder quality than had hitherto been made.

In 1710 Boettger began to make porcelain but his paste was grey and poor, and there was little or no glaze upon it. Accidentally, however, in a most singular way, he discovered the source of the required paste. A rich ironmaster of Saxony, riding near Aue, observed that his horses' feet clung with considerable tenacity to the white clay. He took some of the clay home, dried it, and made it into hair powder. Boettger's hair dresser, having come into possession of some of it, used it on his master's hair, and Boettger, observing that it was heavy and a mineral, tried it for making porcelain. He found, to his great joy, that it was true kaolin. The Elector at once established a porcelain factory at Meissen, 15 miles from Dresden, and made Boettger its director. This establishment was more like a prison than a factory, being surrounded by high walls and shut in by portcullises. Employes were sworn to secrecy. The kaolin was brought in sealed bags.

## The Connoisseur.

(Continued from page 51.)

And thus began the manufacture of Royal Dresden porcelain.

At first the decorations of the Dresden ware were copied from Japanese and Chinese designs, but after 1725 this practice was superseded by elaborate miniature paintings of flowers and insects, or copies from Dutch and Flemish painters. All notion of true ceramic decoration was absent, and the porcelain was regarded only as a ground on which to place an imitation of an oil painting. The chief characteristics of Dresden are its statuettes and groups of figures, the best of which were made between 1731 and 1756 under a sculptor named Kaendler.

Paul Hannog, a deserter from the Dresden factory, tried to make porcelain at Paris in the reign of Louis Quinze, but was unsuccessful because of the lack of kaolin. In 1761 Mme. Darnet discovered kaolin in a ravine at St. Yrieux, near Limoges, after a severe storm, and after repeated experiments hard paste porcelain was first made in France in 1768. In 1780 jeweled Sèvres began to be made at the factory. This ware generally has a ground of ultramarine. It is richly set with imitation jewels, chiefly turquoises, pearls and transparent rubies, made of colored enamel paste, and so natural that they looked like real gems.

## The Rambler's Notes.

WHAT THE RAMBLER SAW AND HEARD AMONG THE DEALERS IN ART POTTERY, CUT GLASS, BRONZES, ETC.

FINE SEVRES,  
DRESDEN, ETC.

A VISIT to the  
warerooms of  
Leon J. Glaenzer &

Co., 80-82 Chambers St., New York, will disclose one of the richest and most extensive assortments of Sèvres to be found in the market. In addition to their various sizes and styles of vases, this firm also show plates, candlesticks, inkstands and other Sèvres novelties of many descriptions. Almost an equally fine assortment will here be found of Dresden, Royal Bonn, Carlsbad, Teplitz and other wares from the finest French, German and English potteries.

NEW PRODUCTIONS IN  
VICTORIA.

THE Victoria ware of Lazarus, Rosenfeld & Lehmann, 60 Murray St., New York, now comprises a new line of white china pieces, decorated with busts of men and women prominent in French history. Among these are Mme. de Montespan, Louis XVI., Louis XV., Cinq Mars, Mme. de Montpensier, Grand Dauphin Philippe D'Orleans, Marie Leczinska, and others. The pieces on which these are shown are principally plates of various sizes, with either embossed or open-work borders; individual and large size teapots, sugars and

creams; cracker jars, tea caddies and pin, pen and brush trays. Similar pieces are also shown with cupid and figure panel decorations.

THREE-PIECE  
BOUDOIR SETS.

AMONG the latest goods opened by the Chas. Jacques Clock Co., 22 Cortlandt St., New

York, are three-piece boudoir sets, consisting of a French chinaclock and two candlesticks. These dainty clocks range from five to seven inches in height, and show a variety of colors and decorations principally cupid, gilt floral designs. About six different shapes are shown in pink, blue, green and other colors, with candlestick side pieces.

VIENNA TABLES.

LEVY, DREYFUS & CO., 11 Maiden Lane, New York, are getting in a line of Vienna tables which they say will greatly interest the jewelry trade. These have painted porcelain tops decorated in Watteau style and with mythological and allegorical subjects, principally reproductions of famous paintings. Their variety of figures, busts and groups has been greatly augmented by two consignments just opened. One of these consists of finely decorated Austrian majolica, and contains pieces ranging in size from six inches to three feet high. The other, Cararra marble figures and large statues, comprises many new and famous subjects.

THE RAMBLER.

# HOLIDAY COLLECTION FOR THE TRADE.

## ORDER ONE.

### NOVELTIES

... FOR THE ...

### JEWELRY • TRADE.



THE FOSTER PATTERN



RICHFIELD PATTERN.



THE ROSE PATTERN.

Our \$75 assortments are  
a Specialty and form a  
complete collection.

P. H. LEONARD, 76 & 78 Reade Street, NEW YORK.



# BAWO & DOTTER,

IMPORTERS, MANUFACTURERS AND  
COMMISSION MERCHANTS,

26, 28, 30 & 32 Barclay Street, = = New York.

ARTISTIC POTTERY AND NOVELTIES FOR THE JEWELRY TRADE.

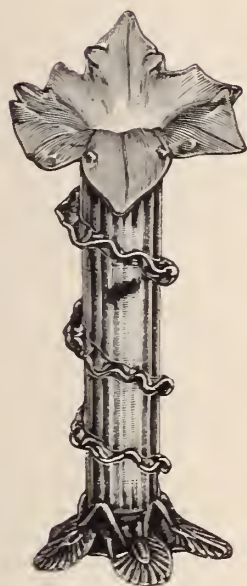

**Flower Tubes.**

Fine English Crystal, Nürrenberg Green and Opalescent.

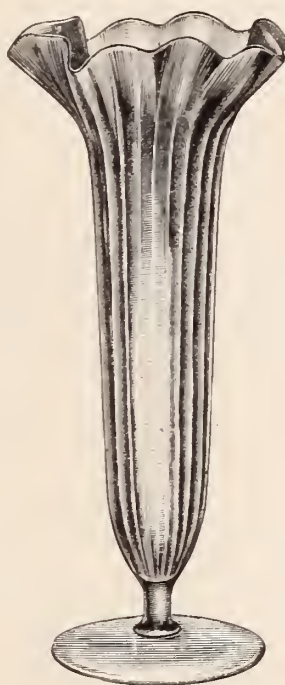

Also a large line in Fancy Shapes, richly decorated in gold. Suitable presents for the Holidays.

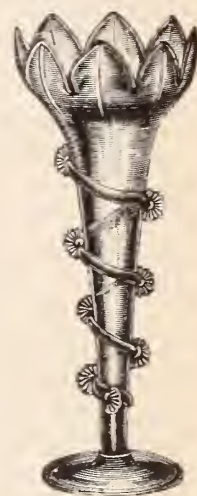

DRESDEN AND ROYAL TEPLITZ CENTRAL DRAFT LAMPS.  
THE LARGEST LINE IN THE CITY.

**PARIS SPECIALTIES.**

A large line of gilt mounted VASES, CARD RECEIVERS, CANDLESTICKS, Etc., Etc., Etc. FAIENCE CLOCKS, and GILT BRONZE CLOCK SETS. SEVRES PLATES, CUPS and SAUCERS. BRONZES, newest designs and latest colors.

A full line of COALPORT, MINTON, DOULTON, ROYAL WORCESTER, COPELAND, WEDGWOOD, Etc., Etc., Etc., also ROYAL DRESDEN, ROYAL VIENNA, ROYAL BONN, TEPLITZ, ROYAL HAN-OVER, and other celebrated makes.

Just received, a large invoice of

**ITALIAN MARBLE STATUARY.**

Never before have we been better prepared to meet the growing demands of Jewelers, for Artistic Novelties in Pottery than at the present season.  
ALL TASTES CAN BE SATISFIED.

New York Warerooms and Office :

26, 28, 30 & 32 Barclay Street.

P. O. BOX, 1872.

**Factories:**

Limoges, Steinschoenau and Carlsbad.

Paris, 32 Rue de Paradis.

Hamburg, Alter Wall, 74.

London, 44 Jewin Street,

Berlin, Commandanten Street, 60.

OUR MOTTO--Quality and Price Speaks Louder Than Words.

# LATEST STYLES ... IN ... FINE JEWELRY.

GOLD BUCKLES,  
HAIR PINS,  
BACK COMBS,  
SIDE COMBS,  
NECK ORNAMENTS, Etc.

John A. Riley & Sloan Co.,  
Broadway and 17th Street,  
NEW YORK.

For **BADGES and MEDALS,**  
Flag Pins, Class Pins, Class Rings  
and Special Work of all Descriptions,  
SEND TO **E. R. STOCKWELL, MANUF'R,**  
19 John Street, New York.

## THE SOUL OF A WATCH.

**L**ITTLE watch, fast ticking out  
All the hours of pain and doubt,  
All the tumult, toil, and strife  
Making up our span of life;  
All the heart wrung sighs and tears  
Falling faster with the years,  
As the petals drop and fade  
From the bloom life's Summer made,  
Ah! what thoughts each other chase  
As I look upon your face.

Every tick your motions give,  
One tick less have I to live.  
Did I realize this thought,  
With such solemn meaning fraught,  
When some new-born joy drew nigh  
In the happy days gone by,  
And your slight hands all too slow  
Round about your face did go?  
Ah! those tardy hours have passed,  
Would they were not now so fast!

Never stopping in your flight,  
Never pausing day or night;  
Not a moment's rest you crave  
From the cradle to the grave.  
With a never ceasing motion,  
Steadfast as the tides of ocean;  
Seeming evermore to hurry,  
Yet without a moment's flurry;  
Till our worn hearts almost pray  
That you would a moment stay.

All things rest—the clouds at noon,  
And the leaves in nights of June;  
And the grief bewildered brain  
When sleep falls like softest rain;  
And the stars when day awakes,  
And the day when Hesper shakes  
Gleams of gold from out the skies  
Into wandering lovers' eyes.  
You alone speed on your way,  
Never resting night or day.

Yet what joy those hands have brought:  
Golden days with rapture fraught;  
Golden days by sunlit fountain;  
Golden days on breezy mountain;  
Days made more divine by love  
Than by radiance from above.  
Ah! those hands that to the sense  
Bring such joys and bear them hence;  
Could we know what Time conceals  
'Neath those little ticking wheels!

Yet when those slight hands shall mark  
That last hour when all grows dark,  
And shall still keep ticking on  
When earth's light from me is gone,  
Little watch, your face shall be  
Still a memory sweet to me,  
Though diviner light may shine  
On these opened eyes of mine,  
For your hands that never cease  
Bring at last the perfect peace.

—Temple Bar.

The Bostonians never speak of money as  
"rocks." They refer to it as "precious  
stones."—Yonkers *Statesman*.

"Do you find any trouble in getting good  
milk, now that you are housekeeping?"

"We don't buy milk. Our bric-à-brac is  
only large enough to hold cream."—Detroit  
*Free Press*.

BACON.—I understand your wife has  
picked out a diamond ring at the jeweler's  
with thirteen stones in it. Don't you think  
thirteen an unlucky number?

EGBERT.—Well, I think she'll be lucky if  
she gets it.—Yonkers *Statesman*.

# CARBORUNDUM.

## Net Retail Price List of Carborundum Wheels.

ACLESON'S PATENT, February 28th, 1893.

Diam. in Inches	THICKNESS IN INCHES.																Rev. per Minute.		
	1/4	3/8	1/2	5/8	3/4	7/8	1	1 1/4	1 1/2	1 3/4	2	2 1/4	2 1/2	2 3/4	3	3 1/2		4	
1	\$.15	\$.18	\$.20	\$.23	\$.25	\$.28	\$.30	\$.35	\$.40	\$.45	\$.50	\$.55	\$.60	\$.65	\$.70	\$.75	\$.80	\$.90	18,000
1 1/2	.18	.22	.25	.28	.31	.33	.35	.40	.45	.50	.56	.62	.67	.73	.78	.85	.90	1.00	14,000
2	.21	.25	.30	.34	.37	.40	.42	.46	.52	.58	.65	.70	.77	.85	.91	1.00	1.20	1.40	11,000
2 1/2	.25	.30	.37	.42	.46	.48	.50	.55	.60	.67	.75	.80	.91	.98	1.05	1.20	1.40	1.80	8,800
3	.30	.38	.45	.50	.55	.58	.60	.65	.70	.78	.85	.95	1.05	1.15	1.25	1.45	1.65	2.00	7,400
4	.65	.70	.75	.80	.85	.90	.95	1.10	1.30	1.50	1.65	1.80	2.00	2.15	2.35	2.70	3.05	3.50	5,500
5	.85	.90	.95	1.05	1.15	1.25	1.35	1.65	1.90	2.20	2.45	2.75	3.05	3.30	3.55	4.15	4.65	5.00	4,400
6	1.10	1.20	1.25	1.45	1.60	1.80	1.95	2.35	2.75	3.15	3.55	3.95	4.33	4.75	5.15	5.95	6.75	7.00	3,700
7	1.35	1.55	1.70	1.90	2.10	2.35	2.60	3.15	3.70	4.25	4.80	5.35	5.75	6.45	7.00	8.10	9.20	9.50	3,160
8	1.65	1.90	2.15	2.45	2.75	3.05	3.35	4.05	4.80	5.50	6.25	6.95	7.65	8.35	9.10	10.50	12.00	12.50	2,750
9	2.01	2.40	2.65	3.10	3.40	3.80	4.15	5.10	5.45	6.90	7.80	8.75	9.65	10.55	11.45	13.25	15.10	15.50	2,450
10	2.45	2.80	3.25	3.70	4.15	4.65	5.10	6.25	7.40	8.50	9.60	10.70	11.85	12.90	14.05	16.30	18.55	19.00	2,200
12	3.60	4.00	4.40	5.10	5.80	6.50	7.20	8.80	10.40	12.00	14.60	15.20	16.80	18.4	20.00	24.55	26.40	27.00	1,830

CARBORUNDUM was awarded both a Medal and a Diploma at the World's Columbian Exposition in recognition of its merits as an Abrasive, the hardness being greater than any other abrasive material.

The wheels are made with a vitrified bond, and pressed under hydraulic pressure. Those over three inches in diameter are turned up after firing. The same numbers are used to designate the degrees of fineness, as are used with Emery, and the wheels are made in seven degrees of hardness, marked SSS, SS, S, M, H, HH, HHH, from extremely soft to extremely hard.

In ordering, state diameter, thickness, hole, number and hardness.

Monongahela, Pa., U. S. A.

THE CARBORUNDUM COMPANY.

Hones, Slabs, Files.

Cut = This = Out.

IMPORTERS OF  
**DIAMONDS.**  
JOBBER'S IN  
Watches, Jewelry, Chains,  
NOVELTIES, ETC.  
Latest Designs. Lowest Prices.

**AIKIN-LAMBERT**  
JEWELRY CO.,  
19 Maiden Lane, New York.  
CHICAGO BRANCH: 103 STATE ST.

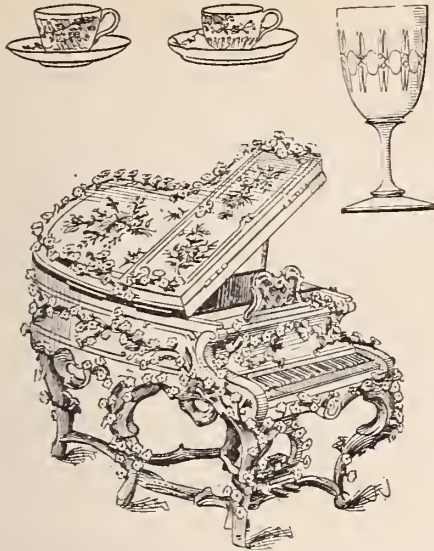

# HINRICHS & CO.,

29 & 31 Park Place, N. Y.

## HOLIDAY GOODS FOR JEWELERS.

ITALIAN MARBLE BUSTS,  
 PARIAN BUSTS and FIGURES,  
 BISQUE FIGURES and GROUPS,  
 FRENCH CHINA CRACKER JARS,  
 CHOCOLATE POTS, TRAYS, BOWLS,  
 SOUVENIR A. D. COFFERS, TEAS, Etc.

ST. GERMAN AND GERMAN-AMERICAN STUDENT LAMPS.

### BRIC-A-BRAC AND ART POTTERY.

SEND FOR CATALOGUES.



**TOWLE**  
 MANUFACTURING  
 COMPANY.  
 MANUFACTURERS

OLD ENGLISH STRAWBERRY FORK.

**STERLING SILVER**  
 TABLE WARE,  
 IN A COMPLETE ASSORTMENT.

149-151 STATE STREET  
 CHICAGO ILL.

Newburyport, Mass.

### BURGLARY INSURANCE.

## Fidelity & Casualty Co.

OF NEW YORK

INSURES Safes and their Contents

Against Burglary.

For Particulars, address the Company,  
 140-146 BROADWAY, NEW YORK

# The Best Chatelaine is the Lady Racine.

## STEEL CASES & SILVER CASES.



10 LINE.

- Made in 10 Line Open Face.
- “ 11½ Line Open Face and Hunting.
- “ 13 Line Open Face and Hunting.

THE SILVER CASES ARE 0.935 FINE.  
 THE MOVEMENTS HAVE 10 JEWELS  
 THE ENGRAVINGS ARE CHOICE.



3 LINE

### MADE IN 12 LINE OPEN FACE.

In Silver Cases only.

Case 0,800 Fine with a 6 Jewel Movement.  
 Expressly Gotten Up to Suit the Times.

## A GOOD Chatelaine Watch at a LOW PRICE.

Do not fail to ASK YOUR JOBBER FOR THE NEW  
 12 LINE LADY RACINE in 0.800 Cases.



12 LINE

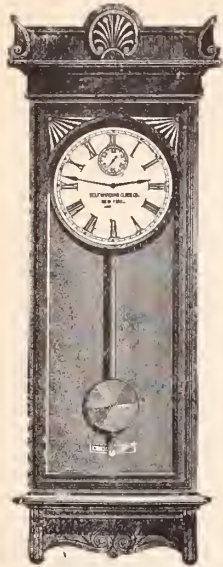

**SELF WINDING CLOCK CO.**

NEW YORK-CHICAGO.

**HALL CLOCKS,  
OFFICE CLOCKS,  
Synchronized Time Plants.**

No Winding. Corrected Hourly

BY TELEGRAPH SIGNALS OVER WESTERN UNION TEL. CO.

Wires from U. S. Naval Observatory, Washington, D. C.

General Office: **26 BROADWAY, N. Y.** Branch Office: **Columbus Memorial Bldg, Chicago.**



**REORGANIZATION SALE OF  
Opera and Field Glasses.**

We have for immediate sale the largest and best selected stock of Opera and Field Glasses in this country, and offer them at fully 25 per cent. below cost. A few specimen items:

- 75 Non-Achromatic Field Glasses**, 24 lines objective, in case,  
REGULAR PRICE, \$3.25, REDUCED TO.....**\$2.00**
- 50 Colmont Field Glasses**, 26 lines objective, in case,  
REGULAR PRICE, \$6.00, REDUCED TO.....**\$4.90**
- 85 Non-Achromatic Opera Glasses**, 15 lines objective, in case,  
REGULAR PRICE, \$9.00 per doz., REDUCED TO.....**\$5.25 per dozen**
- 50 Achromatic Opera Glasses**, leather covered and japanned, 15 lines objective, in case,  
REGULAR PRICE, \$1.75 each, REDUCED TO.....**\$1.35 each.**
- 50 Achromatic Opera Glasses**, leather covered and japanned, finer quality, 12 lines objective, in pocket book case, REGULAR PRICE, \$2.25 each, REDUCED TO.....**\$1.55 each.**
- 40 Achromatic Opera Glasses**, pearl covered, 15 lines objective, in case,  
REGULAR PRICE, \$3.75 each, REDUCED TO.....**\$2.90 each.**
- 36 Achromatic Opera Glasses**, pearl covered, 17 lines objective in case,  
REGULAR PRICE, \$4.50 each, REDUCED TO.....**\$3.70 each**

SEND FOR SAMPLES.

**QUEEN & CO., Opticians,**

J. G. GRAY, Assignee.

1010 Chestnut St., Philadelphia.

**DIAMONDS.**

**C. COTTIER & SON,** IMPORTERS OF PRECIOUS STONES,  
14 MAIDEN LANE, NEW YORK.

C. A. RICHARDS, Agt. 151 Weybosset St., Prov., R. I.

**FANCY GEMS.**

**HAGAN, WHITE & CO.,**

MANUFACTURERS OF

**GOLD AND SILVER MOUNTED CANES, UMBRELLAS & NOVELTIES.**

RICH AMERICAN CUT GLASS, SILVER MOUNTED.  
248 WEST 23D STREET, NEW YORK.

**Diamond Polishing Machines.**

We build these machines complete with latest improvements also polishing wheels, tongs, dousps, weights, shafting, belting, ventilating fans, gear-cutting, die blanks, etc., We do general repair work on jeweler's machinery.

**THE ARTHUR CO.,**

General Machine Works,

86 JOHN STREET NEW YORK.

**U. S. SMELTING & REFINING WORKS.**

Sweep Smelting and Assaying, Platinum in Plate and Wire. Chemically Pure Copper. Ore and Bullion Assays a specialty.

Highest prices paid for old gold and silver. Sole manufacturers of Phoenix Flux and Eureka Alloy.

M. WOLLSTEIN, 25 John St., New York.

**S. F. MYERS & CO.,**

Manufacturing and

WHOLESALE JEWELERS,

1895 Issue, No. 39.

**OUR ROYAL CATALOGUE**

Illustrates all that is new, unique and desirable in

everything that pertains to jewelry. 600 pages, size of this publication. Free to dealers.

SEVEN DOUBLE FLOORS.  
TWENTY-TWO DEPARTMENTS.

Myers Buildings, 48-50 Maiden Lane, New York, 33-35 Liberty St.,



OUR SPECIALTY

The Largest Stock of

CHIMING

AND

STRIKING

HALL CLOCKS

ever shown.

**Chas. Jacques**

CLOCK CO.,

22 Cortlandt Street,  
NEW YORK.

**B. & W. B. SMITH,**

220 W. 29th St., New York.



Improved Dust-Tight Counter Cases, Perpendicular Sliding Doors.

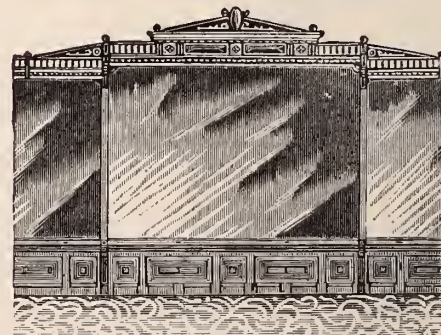

Improved Dust-Tight Wall Cases. Furnished with Improved Shelving and arranged for Electric Lighting.

**IT PAYS** TO KEEP IN TOUCH WITH TRADE AFFAIRS. **THE JEWELERS' CIRCULAR,** For 4c. a Week will do it. **Subscribe!**

DIAMONDS and Cutters. L. & M. KAHN & CO., 172 Broadway, NEW YORK.



# THE JEWELERS CIRCULAR

AND HOROLOGICAL REVIEW.

Copyright by THE JEWELERS' CIRCULAR PUB. CO.

189 Broadway, New York.

Entered at the Post Office in N. Y. as second-class matter.

VOL. XXIX.

NEW YORK, WEDNESDAY, NOV. 28, 1894.

No. 18.

## THE MAIDEN LANE OF PARIS.

SEVEN months out of twelve the Rue de la Paix is, from 2 o'clock to 4 o'clock and from 5.30 to 7 o'clock P. M., the most animated street in Paris. I mean animated, not bustling. Ladies step out of

lingering in preference before the jewelers' displays. English and American visitors to Paris cast a hasty glance at the most striking articles, like people who know the value of time and its equivalent, money.

every day, at least in the best places—some articles in the windows being replaced in turn by others taken from the glass cases—so that the general effect of the show window is frequently renewed. What makes a



VIEW OF THE RUE DE LA PAIX FROM THE PLACE DE L'OPERA.

their carriages on both sides of the street to pay a visit to their dressmaker, milliner, or jeweler, and very often favor each in turn. Elegantly dressed loiterers walk leisurely along, stopping in front of every shop, but

Nothing is more pleasant for people of taste, who happen to have an hour to spare every day, than to take a stroll in the evening in the Rue de la Paix. The arrangement of the jewelry displays is altered

review of all these jewelry stores still more interesting is that every jeweler gives, perhaps unconsciously, a characteristic feature to his display, depending upon his individual taste. The result is, that while they all

ESTABLISHED 1842

*Samuel Little, Pres't**Rufus B. Carr, Gen'l Man'gr.**Arthur M. Little, Treas'r*

OFFICE OF  
**THE E. HOWARD WATCH & CLOCK CO.**

**FINE WATCHES & CLOCKS.**

383 WASHINGTON ST., BOSTON. 34 WASHINGTON ST., CHICAGO.

E.V. CLERGUE, Agent.

41 MAIDEN LANE, NEW YORK.

*New York!*

RETAIL JEWELERS,

GENTLEMEN--WE HAVE RECEIVED many letters from THE TRADE throughout the country from which we judge that an ERRONEOUS IMPRESSION has been given that HOWARD WATCHES cannot be obtained from Jobbers.

We therefore take this method of informing our friends, the Retail Jewelers, that any legitimate Jobber in the country can supply Howard Watches of ANY GRADE OR SIZE desired.

If your Jobber fails for any reason to fill your orders, write directly to us and we will see that you are supplied.

We have also received complaints that Retailers fail to get satisfaction when they send Howard Watches to their Jobbers for repairs, &c., and we earnestly request that any Retailer having trouble of any kind in regard to the PURCHASE, SALE or REPAIRING of our Watches, communicate directly with us.

We will gladly correspond with any dealer upon any point in connection with Howard Watches or Clocks.

The American Watch is the best watch in the world and WE HAVE ALWAYS MADE, ARE MAKING and WILL MAKE the finest American Watch.

We have a thoroughly organized repair department and will now do repair work on Howards at ACTUAL COST.

THE E. HOWARD WATCH AND CLOCK CO.

# LÉON J. GLAENZER & Co.,

80 and 82 Chambers St., New York.

---

**Novelties and Specialties in every Department.**

---

**Clocks.** Gilt, Porcelain, Enameled and Bronze, Crystal Regulators, Traveling Clocks, Hall Clocks with English Chime Movements.

**Bronzes.** Busts and Statues in real and imitation art Bronze and all the Novel Decorations.

**Lamps.** Banquet, Piano, and Princess Lamps, in Decorated Porcelain, Gilt Bronze and Enamel and other combinations.

**Fine Decorated Porcelains and Glassware.**

Sèvres Vases, Plates, Candlesticks, Inks, Flower Holders, Card Receivers, Etc. Table and Decorative Glass.

**Toilet Articles.** All kinds of Brushes, Manicure Sets, Hand Mirrors, Etc.

**Onyx Pedestals and Tables, Bric-à-Brac Cabinets.**

ALL GERMAN POTTERIES.

Dresden, Royal Bonn, Carlsbad, Teplitz, Etc., Etc.

exhibit nearly the same lines of articles, yet we always believe that we see something different in every one of the stores. Boucheron shows his preference for *joaillerie*, yet his *bijouterie* is refined and perfectly finished. Vever has an evident foible for enamel work, although we could not find in any store purer stones than his.

Most of the jewelers' show windows, not only in the Rue de la Paix, but also at the Palais Royal and on the boulevards, are lined with deep red or sapphire blue velvet, gracefully draped at the top and on the sides, with tassels here and there. Articles are arranged on white velvet boards of various shapes. Bracelets exhibiting pearls and cabochon stones which only run half round, the other half being chain work, rest on a kind of roller, so that the jeweled part shows as it would on the arm. Bracelets which are entirely formed of a succession of *motifs* giving all the same artistic effect are laid flat on a slanting ground or propped up on a board. The pure jewelry (*joaillerie*) display is generally arranged on three shelves of different length, retreating like steps, so that the most important piece or pieces placed on the top shall be seen at a suitable prospective distance. Medium sized articles are placed on the next shelf, and those which are either small or adorned with a fine artistic mounting are laid on the lower shelf or on the ground part of the show window.

Let us go down the Rue de la Paix, on the right hand side, coming from the Place de l'Opera. We cast a glance at Hamelin's display, noticing a handsome necklace formed of snowdrops which are big pearls with well known diamond leaves.

We linger awhile before Vever's store. On the left hand side of the entrance are exhibited some fine jewelry: a set of diamonds and turquoises, the diadem consisting of oval rings of diamonds diminishing in size from the center to the sides, the empty space of each ring being partly filled up with an almond shaped turquoise bound with brilliants; the necklace is formed of flat circular rings linked together, each ring containing a pear shaped turquoise hanging from a wire caught in the setting. A train of diamonds and pearls, sets of sapphires, rubies and amethysts arranged with brilliants are exhibited on separate boards at a well calculated distance from each other. On the right hand side of the entrance the display is extremely varied. We see here scattered in a tasteful arrangement, a blue

bell in well shaded blue enamel with rows of brilliants running up the flower in symmetrical lines; a cornflower of enamel flattened and slightly faded, as if it had been kept in a book, this being a bookmark; a scent bottle of rock crystal wrapped with a gold foliage; another in smoked glass with brilliants sunk in the glass and forming pretty arabesques; a fan handle of chased gold and pierced work; a prayer book whose cover is adorned with a scene of a religious character in translucent enamel on various reliefs; an album with an ivory cover inlaid with enameled gold and gems.

A curious piece is a dull gold brooch consisting of a crescent the two ends of which are connected with two thin wires divided by a diamond star; above the wide part of the crescent rises a band of chased gold



BOUCHERON'S, RUE DE LA PAIX AND PLACE VENDÔME.

imitating waves, over which a tiny ship is sailing as if ready to disappear from the horizon; the star sparkles above it. There is also an opera glass mounted in carved ivory, exhibiting ogival escutcheons framing varied flowers in enamel which look like mosaic work. An original inkstand in pale gold is placed at the back of the display, and exhibits a graceful female lying down on the ground, her knees bent in a way to divide the ground in two parts, one to receive the ink bottle and the other the powder.

In continuing along the street, we notice in Morgan's show window some pretty jeweled garters and buckles. In Ravant's display we see a diamond bird giving chase to a butterfly made of rubies, emeralds and brilliants; the bird and the insect are to be held on wires fixed in the hair and will thus appear to move freely above the head. At Mellerio's we especially remark his portrait frames in dark tortoise shell inlaid with translucent enamel flowers.

Let us cross over on the other side of the way and stop before Boucheron's corner store, with its three arched bays on the Rue de la Paix, and three on the Place Vendôme. Articles are exposed in glass cases resting on Louis XIV. tables which stand in front of each window. The entrance occupies one of the bays on the Rue de la Paix. The first show window is devoted to triumphs of the queen of stones. These diadems, necklaces, multifolded bow-knots, sprigs of ferns, fleur-de-lis showing dented slits, corn-poppies with their soft petals closing and waving as if under the action of a gentle breeze, etc., seem formed of assembled diamonds held together by a mysterious power of attraction, so entirely invisible is the frame work. In the next show window we note a few colored stones associated with diamonds, so as to form either classical motifs of various styles, or floral ornaments prettily curled and entwined.

The first show window on Place Vendôme contains dainty articles of chased gold with a few stones sparkling on them here and there. The next display consists of various artistic works. A small enameled gold clock in the shape of a scent burner in the Louis XVI. style; a dagger finely damascened; another in its sheath which is chased in a way to remind us of wicker basket work; a hand mirror adorned at the back with a Watteau scene in aqua fortis *ramolayé*, which looks as if it were

chased; another mirror with a platina frame decorated with pierced arabesques over which run light gold festoons; a bon bon box in violet colored crystal with a cover in cloisonné enamel, looking like refined marquetry and introducing ivory together with particles of precious woods. At the third window on the Place Vendôme, an elegant tea set in silver, in Regence style, rests on a table.

Going back to the Place de l'Opera, we pass by several jewelry stores which all deserve notice. Philip, Ancoc, Bréant et Coulbaux, Coulon & Co. have varied displays, including hair combs, dress holders, tippet fasteners, stay hooks, hat pins in jeweled gold, besides bracelets, brooches, studs, rings in gold and platina finely worked, jewel caskets of artistic designs, and also fancy crystal vases and cups overhung with enameled gold festoons or adorned with metallic stains producing a weird, glowing effect.

MEURICE DUVAL.

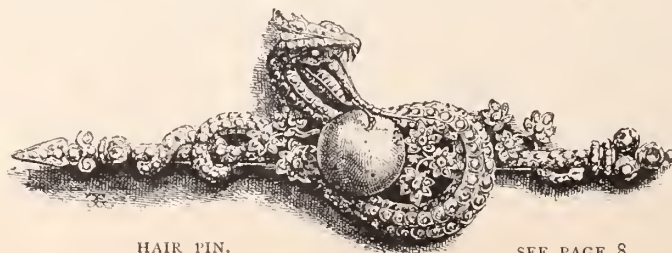

HAIR PIN.

SEE PAGE 8.





# “DELIBERATE CALCULATION”



IS ADMIRABLY PORTRAYED ON THIS FRENCH CHINA PLATE BY OUR DECORATOR,



BUT A BRIEF EXAMINATION of our CATALOGUES will convince you that he who plays a “winning game” with the Purchasing Public can do no better than select liberally from them.

— ONE CENT —

the price of the postal you send us, will bring back a book

TELLING WHAT \$50 WILL BUY IN

**::: CUT GLASS :::**

Then there is HOLLOW WARE of every description,

FLAT WARE, than which no better is made

..... NOVELTIES INNUMERABLE. ....

## A WORD ABOUT CROWN PAIRPOINT FRENCH CHINA.

The JEWELER is not, generally speaking, an importer, yet he sells as nice a class of trade as exists. He can sell Fine China and Cut Glass as easily as Watches and Jewelry or Diamonds. Now we are importing genuine China blanks and decorating them here. We will import—you can buy from us. It will pay you well to talk with us about this.

SILVERWARE CATALOGUE No 10.

CUT GLASS CATALOGUE No. 11.

## PAIRPOINT MFG. CO.,

BRANCH STORES: 46 Murray St., N. Y.; 224 Wabash Ave., Chicago; 220 Sutter St., San Francisco.

Factories and Studio: NEW BEDFORD, MASS.

### CROUCH & FITZGERALD.

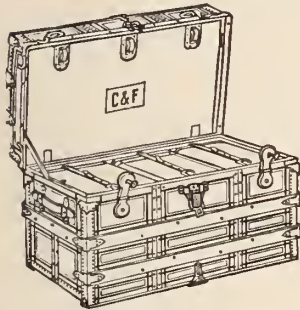

Jewelry Trunks and Cases, 161 Broadway, Bet. Cortlandt and Liberty Sts., 688 B'way, 701 6th Ave., NEW YORK

FLAT WARE AND HOLLOW WARE STAMPED

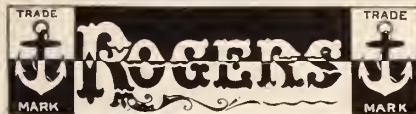

IS THE GENUINE. Manufactured by

WM. ROGERS M'F'G CO., HARTFORD CONN.

**ALBERT BERGER & CO.**  
47 MAIDEN LANE, N. Y.  
Spectacles & Optical Goods,  
GROUND LENSES A SPECIALTY.

We sell to the legitimate Jewelry and Stationery trade only.



CHOICE PAPERS

MAKERS OF

**FINE STATIONERY**

For Correspondence, Wedding and Business Use, handsomely boxed, specially suited to the Jewelry Trade.

18 MURRAY STREET, NEW YORK,

# R. WALLACE & SONS MFG. CO.

## SILVERSMITHS,

WALLINGFORD, - - - - - CONN.



No. 8. TEA BALL AND No. 39. TEA BALL HOLDER.

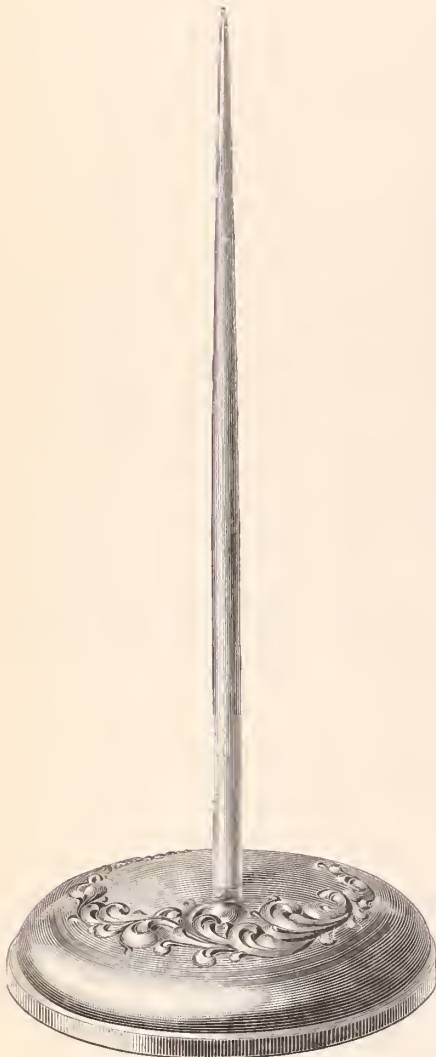

No. 10. PAPER FILE.

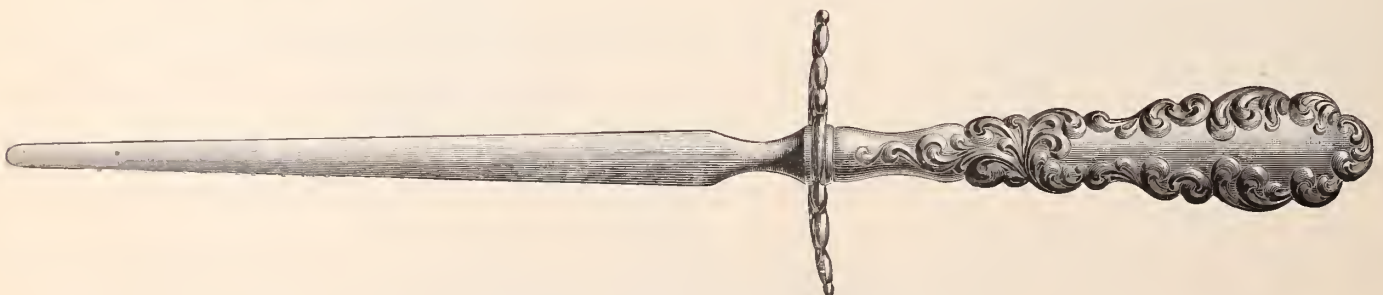

WAVERLEY MEDIUM PAPER KNIFE.

NEW YORK  
226 FIFTH AVENUE.

SAN FRANCISCO  
120 SUTTER STREET.

CHICAGO  
86 WABASH AVENUE.



## THE HOLIDAY SEASON AMONG PARISIAN JEWELERS.

BY PAUL TONNELIER.



CAMEO PENDANT.

**D**URING the holiday season some Parisian jewelers go out of town for several weeks, paying only occasional visits to their stores. They leave experienced and trustworthy salesmen in charge of the business. However, I know several jewelers of mark who would never think of leaving their place more than six and thirty hours from Saturday to Monday every week excepting under special circumstances. I have often seen Boucheron, on a hot Summer day, seated by his elegant table, eagerly examining sparkling novelties in *joaillerie* spread before him, and bending almost amorously over his lovely gems; I have seen also one of the brothers Vever inspecting with a contented smile masterpieces in translucent enamel.

During the holiday season, jewelers have to display a great deal more patience and eloquence to sell a few small articles, than they need to call forth, in the hymeneal months, to obtain important orders for aristocratic *corbeilles de mariage*.

The holiday visitors to Paris are of two sorts: foreigners, and French people from the provinces. The former, as a rule, do not much trouble the jewelers, as they do not desire the articles to be highly praised. When they see in the show window a pretty brooch, an elegant scent bottle, or a quaint bonbon box which takes their fancy, they walk in to ask the price, and if it is exactly what they meant to spend or nearly so, they decide at once upon taking the article. The French *provinciaux* tax to the utmost the patience of the salesman. A store is often invaded by six or eight people together. The girls must know the price of almost everything in the glass cases. They must have a royal necklace and a diadem to match placed on the table in front of them. They admire leisurely a magnificent necklace consisting of diamond leaves and large white pearls forming herries. They believe that the costly diadem showing diamond *fleurons* diminishing in size from the center to the sides, and rising above a band composed of diamond laurel leaves interspersed with pearls, would suit them to a nicety. The sales-

man who has time to spare and is fond of showing the treasures, points out to them how pretty turquoises look when surrounded by brilliants and arranged in a floral design for a corsage garniture, or a shoulder-piece.

The salesman shows them a bracelet consisting of white, pink, gray, and black pearls, divided with emeralds, rubies, topazes, sapphires cut in cabochon, looking like so many round colored pebbles picked up from the sand at the seaside of a fairy land. The girls then examine brooches, some of which are in chased gold, some in enamel, others in *joaillerie*, etc.; one is a medal faintly marked, showing the pure profile of a young saint, with a floweret or a fleur-de-lis in diamond, sunk in the medal near the edge. Another as in the cut is a lovely piece of jewelry in the Renaissance style. The center part shows a large, well

the base, the whole being framed with an oval course of medium sized diamonds, which forms a pretty arrangement for a finger ring. On each side a graceful female in enamel in a *gaine*, holds a band con-

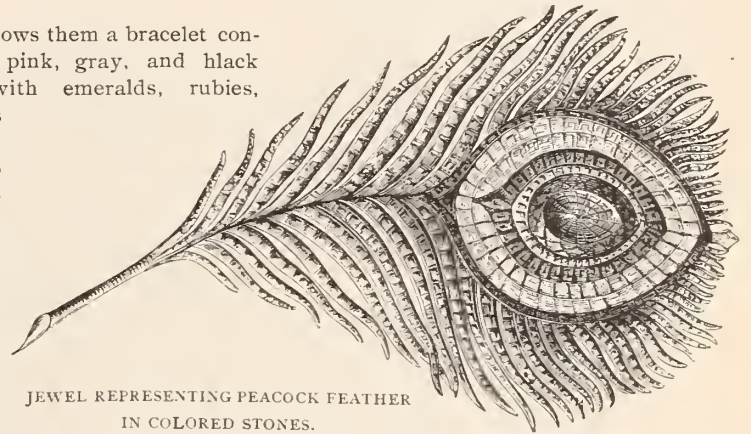

JEWEL REPRESENTING PEACOCK FEATHER  
IN COLORED STONES.

sisting of diamonds which falls and is caught by a curling ornament. The light gold work at the top and at the base completes the harmony of the ensemble, and so do the uppermost pearl and the five pearl drops.

Another diamond brooch of a Greek design, (page 8) also attracts the attention of the girls. They find it rather elaborate, but they can see that the outlines are well balanced, and the general effect very light and harmonious. They look with interest at a pendant, which exhibits a fine cameo soherly yet tastefully mounted. The girls thought cameos were thoroughly out of fashion, but they must acknowledge that those exhibited here and there in the Rue de la Paix are far from looking out of place. They are perfect masterpieces.

In the meantime, a young fellow in the party examines some cane tops, and is quite amazed at the variety of these articles. One is in godroned gold with a cat's eye at the top, another is in lapis-lazuli with a snake curling round it and resting on the knob its flat head with a ruby sunk in it. One cane top opens and discloses a cigar holder in amber decorated with light *motifs* made of brilliants; another, of a long horizontal shape, contains ivory slabs a gold pencil, etc.

The visitors who have been a long time in the store making a complete inventory of its contents, dare not go out without purchasing something. They tell the salesman that, for the present they will just buy a hatpin for one of the girls, as a *souvenir* of their visit to the store. But there are so



JEWEL IN RENAISSANCE STYLE.

faceted sapphire surrounded by brilliants set in dents divided with pearls; a fine gold foliage spreads at the top and underneath

many patterns in these articles that to choose is not an easy matter. Will they

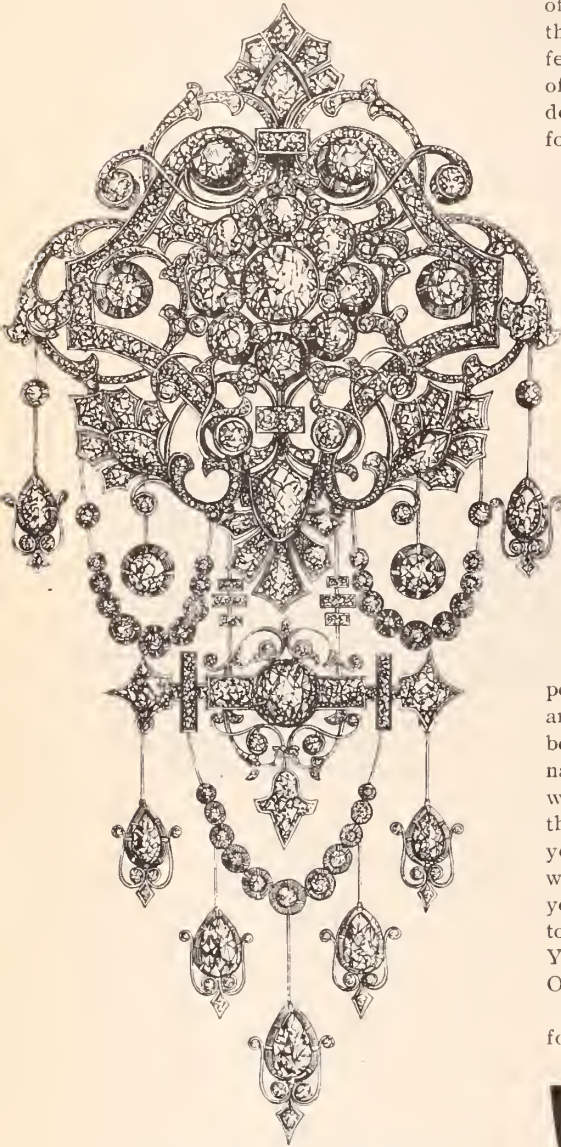

DIAMOND BROOCH IN GREEK DESIGN.

take a diamond caduceus with rubies and peridots here and there, an arrow of ivory adorned with colored stones, a bird of enamel with displayed wings, a hand of chased gold holding a pearl, a tiny bunch of violets formed of amethysts, a Harlequin's head, a cupid cut out of a moonstone? They choose an original pattern, namely, a chestnut with its prickly shell of green gold partly off, so that the chestnut, a ruby in cabochon, shows prettily inside the shell.

The holiday season ends at the beginning of November. Therefore it is during the last fortnight in October that the jewelers' displays are especially attractive. Particularly is this so after 6 o'clock in the evening; then the *joaillerie proprement dite*, well arranged and exposed to a proper light, neither too dull nor too glaring, has its maximum of effect. Such pieces of pure jewelry like the necklace formed of diamonds and pearls reproduced in our cut (so clear that no description is wanted), surrounded with other articles exhibiting the

same refined taste, and sufficiently distant from each other not to force themselves at once upon the attention, form certainly one of the most magnificent sights. Among these articles, let us mention a peacock feather (page 7), whose center or eye consists of oval lines of sapphires, rubies and peridots, the radiating part of the feather being formed of brilliants; and a handsome pin to thrust into the hair (page 4), showing a crawling chimera in colored stones with its tail curled around a diamond bar and its claws resting on a large pearl.

### The Three Watches.

THE captain had just been presented with a handsome watch—a testimonial from his passengers for his presence of mind and untiring devotion to duty in extreme danger. "Speech! speech!" was the demand.

So, laying the case in front of him, he spoke as follows:

"Ladies and gentlemen, my first watch was stolen. I stole it. It happened in this way. I was a captain's son, and sailed around the world with my father before my head was as high as the binnacle. We were in southern seas when I was promoted to knickerbockers and thought myself an A. B. full blown, I assure you. You think the danger through which we have just passed was extreme, but I fear you have rewarded far too generously a man to whom this storm was but half a gale. You should have been with me in the Indian Ocean the day I stole my first watch.

"The bo'sun had piped all hands on deck, for the glass had dropped in ominous fashion and there was no time to be lost. I answered the summons and when the order to furl all sails was

given, I sprang to the lanyards and before any one could catch me was up the mast and out on the yard arm, tugging at the ropes and determined to do a man's duty before a man could interfere. The bo'sun stood aghast, but my father's quick eye saw me in an instant. 'Come down,

handle covered with a tracery of silver. They will be a conspicuous feature of the 5 o'clock tea table this season. The cups to be used with the Rookwood teapots each reflect in color one of its varying tints, and are harmonious in design, and pretty in shape.

sir,' he thundered. Though my legs had not trembled till that moment I could have dropped headlong from terror. I obeyed, but before I reached the deck the vessel gave a mighty lurch, for the storm was upon us. I clutched the lanyards and held on but it must have been my guardian angel who prevented me from being hurled into the sea.

"I leave it to you fathers to picture the agony my father must have suffered when he saw me descending. Scared and miserable I crept to his side. But the storm had come and if he would save his ship there was no time to look after his son. I got up and followed him step by step across the quarter deck, back and forth, watching every movement, echoing every order. I don't think he knew that I was there for a long time, for every nerve was at full strain. Suddenly he turned and saw the forlorn little figure that I must have presented. Catching me by the ear and lifting me to the ship's ladder he said, 'To your cabin, sir, it's not your watch!'"

Before the laughter had subsided, the captain continued: "My second watch was a sell. It was sold to me and I was sold to the tune of \$12. 'It was a fool sheveled, it was a pe-a-u-tiful watch and der mon dot zold it to me toldt me dot he would not bart mit it only dot his fader was det and der widow needte to money padly.' He wore crape on his hat, he looked mournful and he kept a shop on Chatham Square. How was I to know that he was a fraud? I was not a subscriber to Dun or Bradstreet. It was a case of Watch and Prey.

"And now, ladies and gentlemen, for my third watch I have but to say, Thank you. May it never be stolen; it shall certainly never be sold, and once more, thank you."



NECKLACE OF DIAMONDS AND PEARLS.

given, I sprang to the lanyards and before any one could catch me was up the mast and out on the yard arm, tugging at the ropes and determined to do a man's duty before a man could interfere. The bo'sun stood aghast, but my father's quick eye saw me in an instant. 'Come down,

handle covered with a tracery of silver. They will be a conspicuous feature of the 5 o'clock tea table this season. The cups to be used with the Rookwood teapots each reflect in color one of its varying tints, and are harmonious in design, and pretty in shape.

# H. M. SMITH & CO.'S LATEST SUCCESS.

Sales exceed our most sanguine expectations.



Cut about one-half size of Tray.

Send for our New Catalogue, just issued.

**\$9.00**  
EACH  
LESS CASH DISCOUNT

**\$9.00**  
EACH  
LESS CASH DISCOUNT

## 83 Nassau St., New York City.

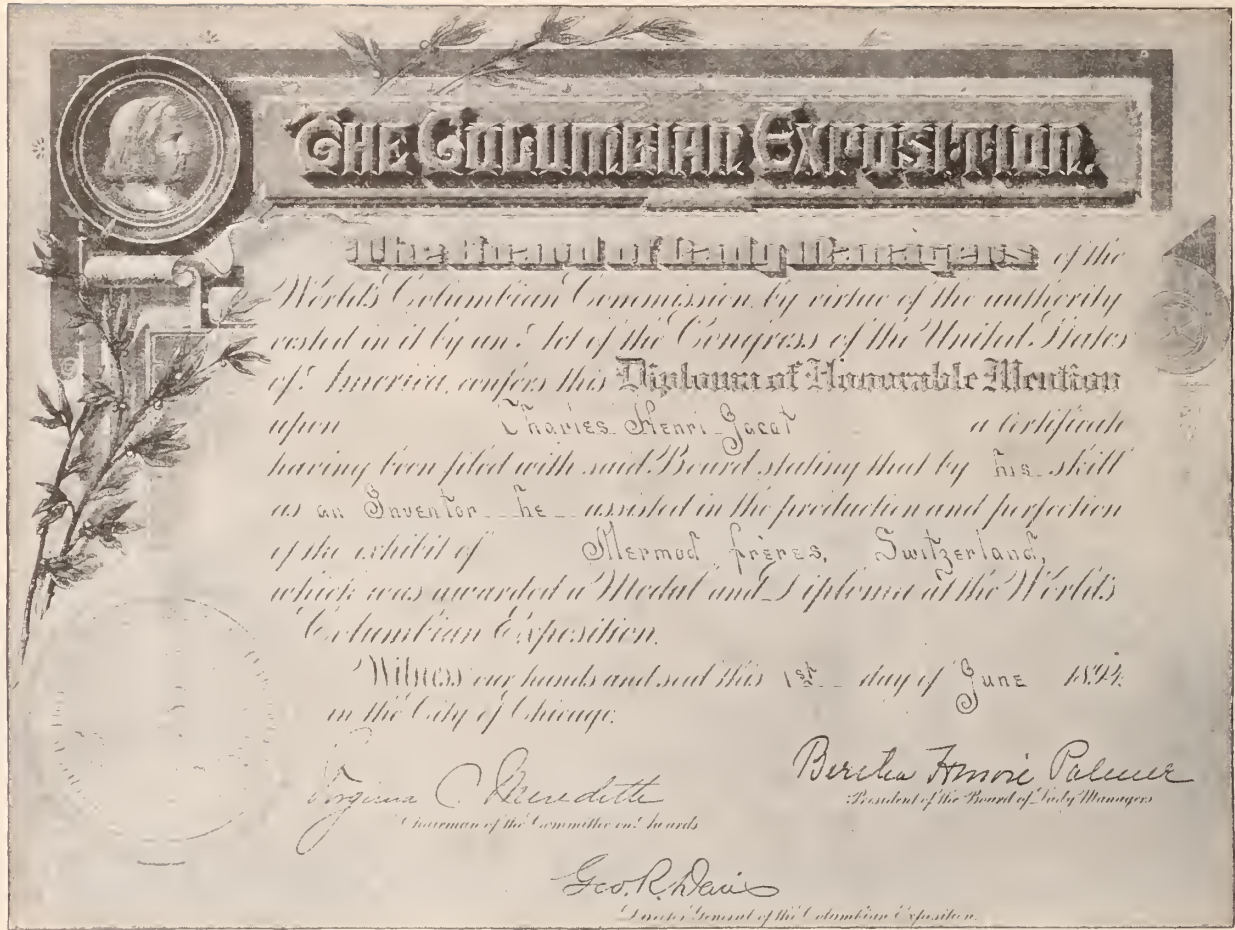

**TESTIMONIAL TO JACOT & SON.**

JUST OUT,

**THE PEERLESS FORTE PICCOLO.**

Send Business Card for Catalogue and Prices to the Trade.

**JACOT & SON, 39 UNION SQUARE, NEW YORK.**

**Paul : Jeanne's : Revolving : Hairpin.**

THE LATEST NOVELTY.

220 Fourth Ave., cor. 18th St.,

NEW YORK.

**WOOD & HUGHES,**  
**STERLING SILVERWARE MANUFACTURERS**  
 New York Agents for the Derby Silver Co.'s  
**FINE QUADRUPLE PLATED WARE,**  
 No 16 JOHN STREET, NEW YORK.  
 206 Kearney St., San Francisco, Cal.  
**HASKELL & MUEGGE, Agents.**

**AIKIN, LAMBERT & CO.,**

CHICAGO BRANCH: 103 State Street.

No. 19 MAIDEN LANE, NEW YORK.

Manufacturers and Exporters  
Gold Pens, Holders, Pencils,



Toothpicks and Novelties

**MERCANTILE**



**FOUNTAIN PEN.**

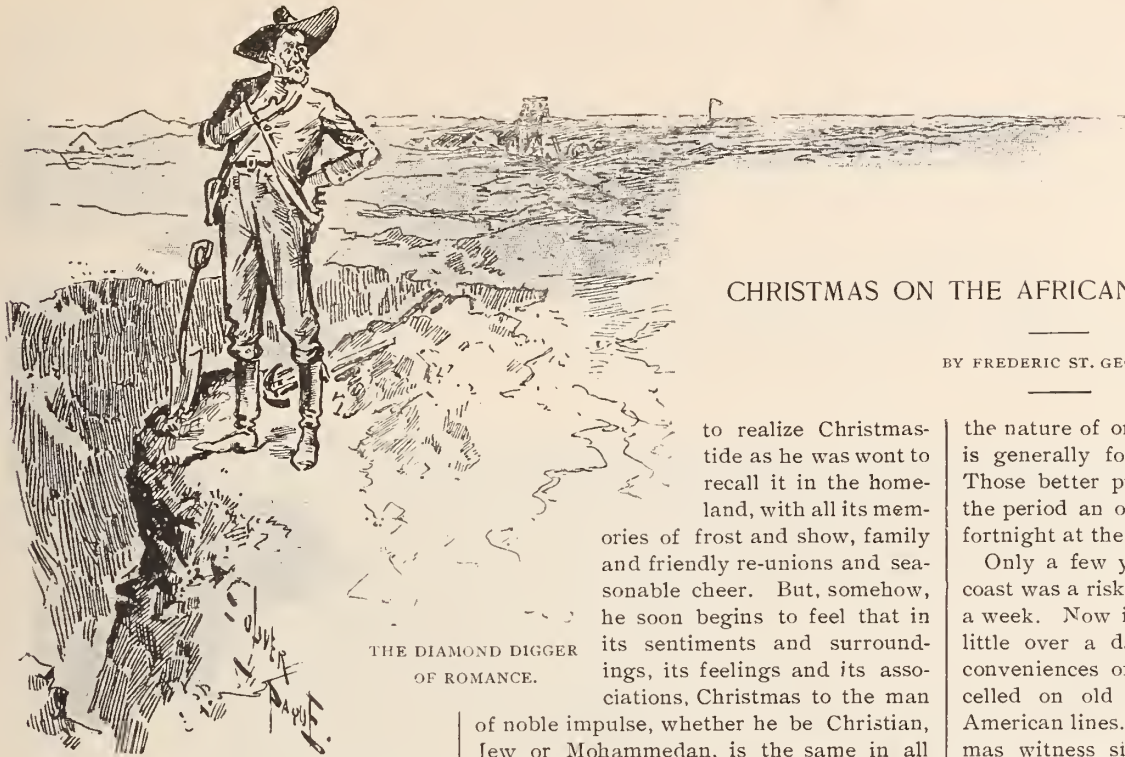

THE DIAMOND DIGGER OF ROMANCE.

With the thermometer at ninety degrees in the shade,  
And the servants in linen jackets arrayed.  
One with a brush to keep off the flies,  
Still the traditions of Christmas we prize.  
The pudding is carved; each eats a slice,  
And we think of such things as snow and ice,  
And we envy our friends at home—are we silly?—  
The delightful sensation of feeling chilly.

NO less an authority than Leigh Hunt has hazarded the opinion that there is absolutely nothing new to be said or written regarding Christmas. From an Old World point of view the subject is doubtless hackneyed, but still amid the varying conditions and phases of South African life the period seems always to re-invest itself with novel and generally pleasurable feelings and associations. We are a remarkably cosmopolitan community on the South African Diamond Fields, and we have been so ever since the news really got abroad, about 1870, of the finding of the first glittering pebbles on the banks of the sluggish, yellow vaal. Laplanders excepted, there are to-day on these Fields, representatives of every European nationality, besides a few Americans, Indians, Chinese, Arabs and nondescript colored races other than African.

The great majority of us are from climates where Christmas weather bears a marked contrast to that usually prevailing here at the festive season. Indeed, here in this sunny clime, with the temperature perchance at ninety degrees in the shade the average European at first finds it difficult



SEEN ON THE STREET ON CHRISTMAS EVE.

to realize Christmas-tide as he was wont to recall it in the homeland, with all its memories of frost and snow, family and friendly re-unions and seasonable cheer. But, somehow, he soon begins to feel that in its sentiments and surroundings, its feelings and its associations, Christmas to the man of noble impulse, whether he be Christian, Jew or Mohammedan, is the same in all times and in all climes.

From the records of careful observers in Europe and America one is led to think—somewhat sadly I confess—that Christmas has become much of a season of “make believe” utterances and conventional inanities, and that there is little left of the old and glorious traditions which the best of our poets and writers strove to keep alive. I am glad to be able to observe that the modern fashion has not yet reached us and that the visitor from Europe or America may yet find a people mainly of the English speaking race, who continue to prize the glorious traditions of the season and still conserve in their minds and hearts all its pathetic memories and sympathies, its ideal consummations and its divine fulfillments. Residents of the crowded centers of the Old or New World may have forgotten the idea that the men and women on the South African diamond and gold fields are a rough lot, and that the amenities of life are not observed in such kindly fashion as in communities where there is more polish and veneer. In that they are greatly mistaken. I have lived half my life in Europe, during which I saw much of men and their customs under many varied conditions. The latter half has been spent under South African skies, and I honestly affirm that I know of no commendable attribute of the British race which has degenerated in this region of sand and sunshine. On the contrary if I was looking for a display of the noble instincts of humanity at the Christmas period I would feel more certain of finding them here than in any European community with which I am acquainted. How we generally spend Christmas, you would probably like to know. Well, there is no stereotyped fashion here or elsewhere. For one thing, we suspend everything of

CHRISTMAS ON THE AFRICAN DIAMOND FIELDS.

BY FREDERIC ST. GEORGE.

the nature of ordinary labor. The holiday is generally for a period of three days. Those better provided for who can make the period an opportunity for a week or a fortnight at the seaside, do so.

Only a few years ago a journey to the coast was a risky and disagreeable affair of a week. Now it can be accomplished in a little over a day and with comforts and conveniences of railway traveling only excelled on old established European or American lines. A few days before Christmas witness sights and incidents at the railway station almost exactly similar to what are customary features in Europe during the height of Summer. The period is, of course, our Mid-Summer and pater and mater at the head of the jubilant hopefuls, is a common sight. Then there are arrivals from the coast. In South Africa the dweller in an inland town generally wants his holiday by the briny; the dweller by the briny usually comes to the interior, and, above all other centers, Kimberley is particularly popular. There are pleasant reunions of old friends and families, and the sights and sounds on Christmas Eve are invariably suggestive of festivity. At no time during the quarter of a century of Diamond Fields history has depression been so prevalent as to prevent the masses from honoring the period to a full and reasonable extent. Too often, in times of real, genuine prosperity, it has been honored in characteristically profuse fashion, and the libations to Bacchus have been memorable.

At the present day, however, there is nothing observable in Kimberley at Christmas-tide to denote that the liquor traffic is not controlled by licensing laws founded upon those determined by wise jurists in reputedly the most highly civilized centers. Any new arrival from Europe or America reaching this spot on Christmas Eve might find himself beneath an almost peerless moon. On every hand he would hear the reports of fire-works and observe fantastic rockets ascend. Whence came this curious Summer custom, he might find it hard to



DOWN ON HIS LUCK ON CHRISTMAS EVE.

AN INTERIOR VIEW SHOWING PART OF THE

THE **WELDING ROOM**

IN THE **TORTOISE SHELL FACTORY OF**

**Rice & Hochster,** 485 BROADWAY,  
.....NEW YORK.

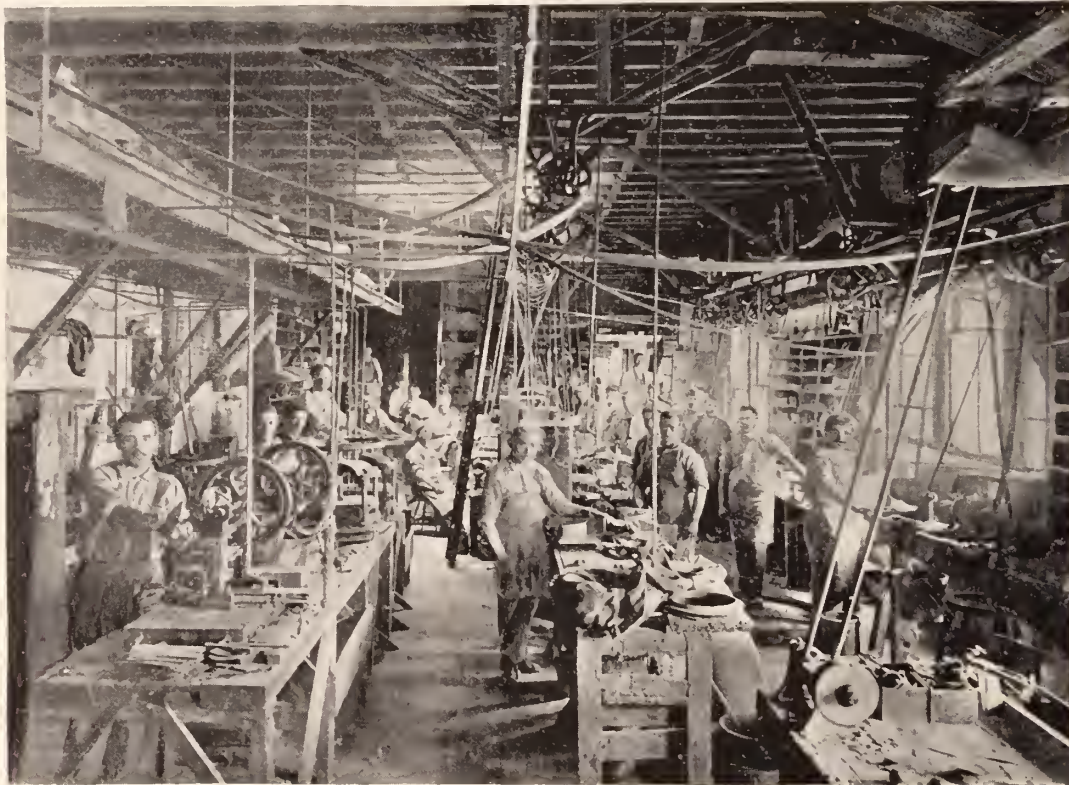

# Facts



We employ more men than any Tortoise Shell Factory in the world.

Highest Award at the World's Fair in Chicago.

We manufacture anything that can be made of Tortoise Shell.

We consume more than half the annual catch of Tortoises in the world.

We make the greatest variety of Rich Designs and are the Leaders of Fashion in our line.

Our new Spring Designs will be out in January.

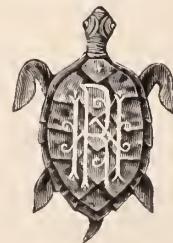

TRADE MARK.



ascertain. It is peculiar in South Africa, though perhaps it is as much the vogue in other sub-tropical climes. He would find the streets thronged with people whose chatter was mostly the English tongue, but whose faces and apparel suggested far distant regions.

The brilliant lights—Kimberley by the way was one of the first places abroad to adopt the electric lights—and the contented, happy look upon most faces would strike him strongly, and the fashionable clothes and costumes would make him rub his eyes and wonder whether he was in Paris,

have made him a stranger. He might then shake hands with three hundred people whom he had never seen before, not one of whom would be impolitely inquisitive as to his business amongst them, and he would probably have a score of invitations to join at the dinner table next day. At midnight three familiar melodies would greet his ear at every turn. These would be "Christians, Awake," "While Shepherds Watched Their Flocks by Night," and "Auld Lang Syne." Here and there might be faint echoes of great national airs such as "The Watch on the Rhine," "The Marseillaise,"

pathetic individual indeed who does not in some way respond. Their musical performances cannot be chronicled as high class, but they are in a sense romantic and remind the intelligent observer how much akin is humanity, no matter what its creed or color.

Altogether, from what I have seen of the African native in his festal or his fatal mood I feel honored to subscribe to the lines:

"Yet let us not these simple folks despise,  
Just such our sires appeared in Cæsar's eyes,  
And in the course of Heaven's evolving plan,  
By truth made free, the long scorned African,  
His maker's image radiant in his face,  
Amongst earth's noblest sons shall find his place.

Possibly I may be a few years in advance of my time in regard to the last line, but I happen to believe it. To hear those of the better sort sing the most approved Christian Christmas carols and with sentiment and pathos would convince the most indifferent that there are wonderful possibilities for the South African natives.

And what would be the Christmas fare in a well appointed Kimberley household? More than you would anticipate. The viands would be nearly equal to the best Paris, London or New York has ever been known to supply. Under local associations, that is, if you were in the exact mood and fully realized what Shakespeare wrote about good digestion waiting on appetite and health or both, you would find that Champagne, Sauterne and Burgundy, with Claret. Port and Sherry, touched light, will help digestion and leave you bright and merry.

That, of course, is one side of human life here. But the poor, and there are none as the word is understood in Europe or America, get grand times. No question is asked as to nationality or creed, they are all well served. We have not reached that acme of civilization, the Union Workhouse. The Kimberley Hospital, I think one of the noblest institutions under the sun, is one of our receptacles, and the others—well we should not be worthy of being considered good Christians if we allowed one hand to know much about the other. I shall not proceed much further, but conclude by remarking that on the South African diamond fields you will find white humanity fully up to the average.

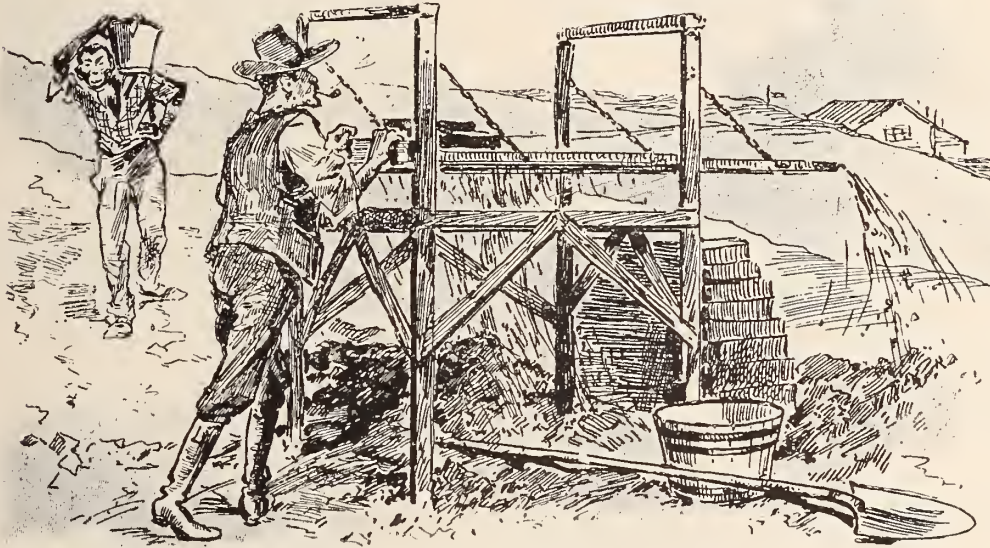

WORKING A "BABY" SIEVE AT THE "RIVER."

London, or New York. If he stepped into one of the hotel bars he would see hand-shaking and hear old fashioned toasts which might remind him of what he had read of old country customs half a century ago. Should he feel disposed to stay there till midnight he would probably have more offers of hospitality than he would have in any other city in the world. And if he "joined in" and proved to be a genial Freemason and a man of good record elsewhere he would probably, under a glorious South African sky, be singing "Auld Lang Syne" with greater fervor than he had ever warbled it hitherto.

If the said visitor entered any of the numerous churches or chapels he would hear noels and carols from the best of sources in Europe and rendered with Christmas feeling to which modern fashion might long

or "Haydn's Hymn," which, you will be aware, is the Austrian national anthem. Nowhere, however, would he be likely to hear anything that would jar upon his national susceptibilities; his difficulty would be to assimilate with such varied national colors and such frank good humor and *bonhomie*. He would see but little of the native population, such an interesting feature of Diamond Fields life, until next morning when the spectacle might be one to remember. I doubt if the African natives have the sense of the grotesque or the love of melody so prominent in the American negro, but they can make themselves most amusing and entertaining subjects. Dressed in nearly every known color and fashion their applications for "Kessmes Boxes" are generally accompanied with so much that is human that he is a cold, unsym-

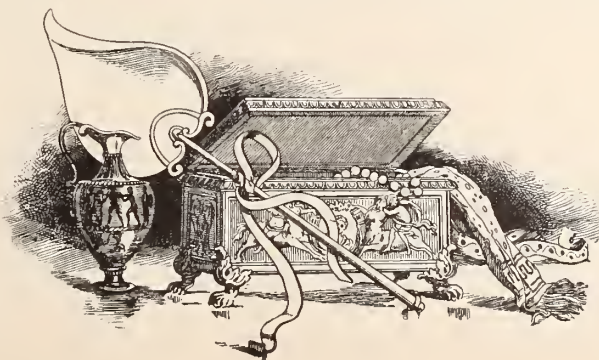

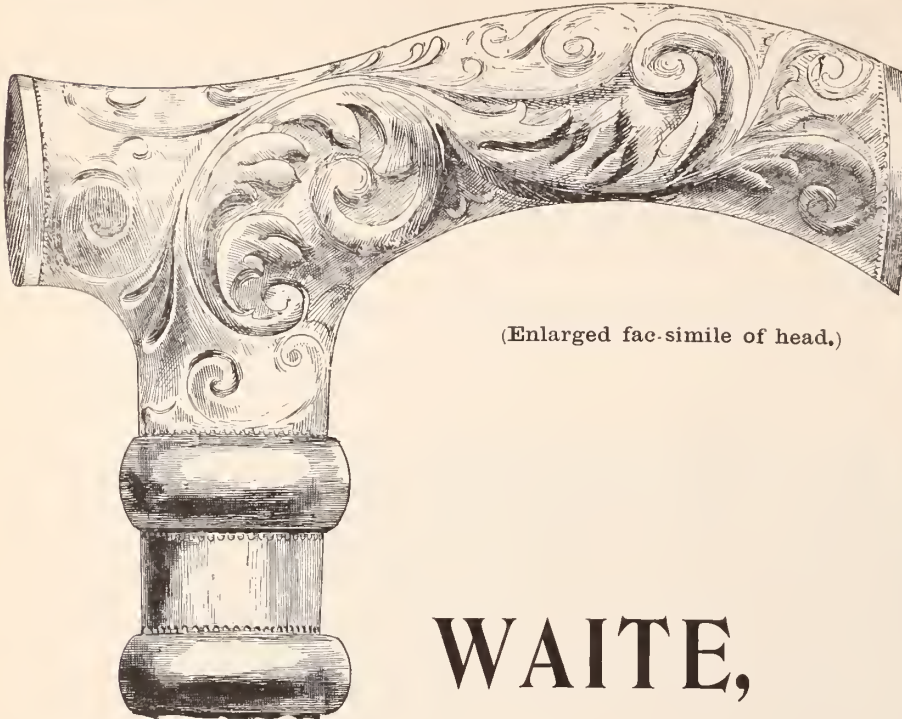

(Enlarged fac-simile of head.)

OUR  
CANE  
Stick  
And  
Lapel  
Pins.

PATENTED  
OCT. 23, 1894  
ARE  
THE  
PROPER  
THING.

HEADS  
ARE OF  
SOLID  
GOLD OR  
STERLING  
SILVER,

Artistically  
CHASED.  
STICKS  
ARE  
ENAMELED  
TO  
REPRESENT  
NATURAL  
WOODS.

THEY SELL AT  
SIGHT.

WAITE,  
THRESHER  
COMPANY,

Providence, R. I.

ONE TRIAL

OF OUR WORK ON REFINING OF  
ALL KINDS WILL CONVINCING YOU  
THAT OUR RETURNS ARE THE BEST



CONVINCE YOURSELF.

**GEO. M. BAKER,**  
Gold & Silver Refiner  
*and* Sweep Smelter.  
PROVIDENCE, R. I.



SPECIALTY: SALES OF  
**JEWELRY BRIC-À-BRAC**  
AND  
ARTICLES OF VERTU

**BURGLARY  
INSURANCE.**

**Fidelity and Casualty Co.**  
OF NEW YORK

**INSURES** Safes and  
their Contents  
**Against Burglary.**

For Particulars, address the Company,  
40-146 BROADWAY, NEW YORK.



# The Best Chatelaine is the Lady Racine.

## STEEL CASES & SILVER CASES.



10 LINE.

Made in 10 Line Open Face.  
 " 11½ Line Open Face and Hunting.  
 " 13 Line Open Face and Hunting.

THE SILVER CASES ARE 0.935 FINE.  
 THE MOVEMENTS HAVE 10 JEWELS  
 THE ENGRAVINGS ARE CHOICE.



3 LINE.

## MADE IN 12 LINE OPEN FACE.

In Silver Cases only.

Case 0.800 Fine with a 6 Jewel Movement.  
 Expressly Gotten Up to Suit the Times.



12 LINE

A GOOD Chatelaine Watch at a LOW PRICE.

Do not fail to ASK YOUR JOBBER FOR THE NEW  
 12 LINE LADY RACINE in 0.800 Cases.



TRADE MARK.

# WATCH CASE COMPANY.

MAKERS OF Fine Gold Watch Cases.

TO THE TRADE...

WHEN YOU SELECT YOUR HOLIDAY STOCK  
 of Gold Watch Cases remember that  
 you make no mistake by asking for



CASES.

ABOVE TRADE MARK

in every Case, and you can depend on Quality of Gold as  
 well as of workmanship.

THROUGH JOBBING TRADE ONLY.

REMEMBER that we have reduced our Photo Miniatures to  
 \$2.00 éach, and make nothing but first-class work.





## THE GEMS OF THE CHRISTMAS MONTH.

BY ELSIE BEE.



**A** POETICAL conceit that has been handed down through countless generations is one that assigns to each month of the year a precious stone. The source of this conceit it has pleased archæologists to place in Aaron's breastplate with its twelve gems symbolical of the twelve tribes of Israel. Like other inheritances from remote ages, this allotment of gems for the months comes to us surrounded by a halo of mystery which enhances its attractiveness with beguiling vagueness and affords not only occasion for mistaken identity but a choice oftentime, in consequence of its refractions, of more than one stone. For instance the month of April viewed through a Hebrew's horoscope, discovers the sapphire as the gem for this month, while a Pole would agree with the eighteenth century archæologists in proclaiming the diamond as the true and only April stone.

In some instances the selection of gems for the months has been exceedingly suggestive; in example of which may be cited the assignment of the emerald for the month of June with its brilliant greenery, and the topaz with its gold and green apportioned to November in the sere and yellow leaf.

It is a fortunate circumstance for all who have regard for this appeal to the fancy, that December with its great Christmas festival is favored with two stones, and such stones, the turquoise blue and the ruby blood red. The felicity of the glowing ruby for December is attested by the fact that it is thus apportioned in six out of eight so-called authenticated lists representing different nations and ages. The refraction in the remaining two lists is the turquoise of the Poles, Russians and many of our own mineralogists. As the turquoise is at the present moment a *prîme* favorite, very fashionable, and sufficiently abundant to come within the reach of the average buyer, it goes without saying that it is the winning December stone in the race after popularity against the rarer and costlier ruby.

The fine turquoises all came formerly from Persia, and jewelers experienced

great difficulty in disposing of other than Persian stones. But of late years extensive finds of turquoise in this country has wrought a wonderful change: American turquoises in many instances rival all others, with their unexceptionable color; this is especially true of the turquoise of Mexico and Arizona. Along with this abundance of fine specimens has come, very naturally, a largely increased demand that places the turquoise among the most popular of the colored stones. It is interesting to note, in this connection, that, in spite of the financial depression \$143,136 worth of American turquoise was sold in 1893, a greater amount probably, according to as good authority as George F. Kunz, than has been sold from Persian mines in a single year. Turquoise is found varying from white to a fine azure blue, occasionally greenish, but it is only the fine blue stones that are of value.

This favorite has, unfortunately, the peculiarity of changing its hue in a very rapid and mysterious manner. A fine blue stone will often turn to a sickly green or whitish tint, especially when brought into contact with acids, musk, camphor and other pungent scents. The fact that turquoise does vary in its color in an unaccountable manner gave rise probably to the old superstition that the gem by its changes indicates the state of health of the wearer.

"A compassionate turquoise that doth tell  
By looking pale, the wearer is not well."

In some portions of Germany the turquoise is the gem appropriated to the *gage d'amour*. Presented by the lover on the acceptance of his suit, the permanence of its color is believed to depend upon the constancy of his affection. This stone being as liable to change and caprice as the human heart itself, the omen it gives is verified with sufficient frequency to maintain its reputation for infallibility.

Among the virtues formerly ascribed to the turquoise is one that would spare the now frequent shame of the divorce court, as it was believed to take away all enmity and to reconcile man and wife. Among the ancients, the turquoise was accepted as a monitor of poison. Pliny shared in the Oriental belief that this gem was lucky and brought health and fortune to the wearer. Fragments of turquoise which appear to have been parts of amulets are frequently met with in the ruins of ancient towns in Egypt.

"Friends and lovers for December, fortune, fame,  
If an amulet of turquoise bear her name."

The sentiment attached to the turquoise in these modern days is prosperity. As a birthday stone, we are told:

"If cold December gave you birth,  
The month of snow and ice and mirth,  
Place on your hand a turquoise blue,  
Success will bless what e'er you do."

The turquoise is at the present time popularly worn as a central stone in finger rings, brooches and scarf pins, being surrounded or otherwise associated with diamonds.

The value of the ruby, when perfect, exceeds that of other gems. The rare occurrence of specimens of the desired vivid "pigeon's blood" color of any size, causes the value to increase in an even greater proportion than that of the diamond. We have been taught to believe that in Burmah alone this gem is unearthed in its purest and most fiery form. The intense "pigeon's blood" color and peculiar fire of the Burmese ruby give it extraordinary value as compared with other red stones which come into rivalry with it.

Our own mineralogists have been greatly interested of late in the finding of small rubies of fairly good color in North Carolina, for this find indicates the possibilities of larger and better stones by more extended development.

Owing to the rarity of a fine ruby, this peerless gem is not popular, for popularity necessitates abundance; but it is always sought for and greatly prized by all who can afford luxuries, and, like the emerald, is never out of fashion. There are, however, rubies which are either flawed, specky, or of too deep or too pale a color, which cost far less and to all but connoisseurs are attractive. These imperfect rubies, along with stones known in the trade as spinels and Balas rubies, are largely employed in jewelry with and without brilliants. In ancient times the words "ruby" and "carbuncle" were applied indiscriminately to all red stones and even now these terms are frequently applied to various stones. The *tourmaline* for instance is called a Brazilian ruby, when of a red color; the same term is also occasionally given to the artificially colored topaz. This loose nomenclature is liable to deceive the inexperienced.

The ruby is not without its so-called magical properties. The Greeks and Romans wore it as an amulet against poison, plague, and evil spirits. It was also supposed that it kept the wearer in

Ferd. Fuchs & Bros., Makers of Sterling Silverware,  
 808 AND 810 GREENWICH STREET, NEW YORK.



NO. 56—TWO-THIRDS SIZE.

THIS LINE OF  
SCISSORS IN ALL  
SIZES.



NO. 56—FULL SIZE 6 1/2 INCHES.

Toilet Sets  
 COMPLETE.

ARNSTEIN

BROS. & CO.,

IMPORTERS AND

DIAMONDS.

CUTTERS OF

CUTTING WORKS,  
45 JOHN STREET.

37 MAIDEN LANE, N. Y.

health and good spirits, and it was believed that if he or the donor were in danger of any kind, the gem would become black or obscure and would not re-assume its pristine color until the peril had passed away.

At one period the ruby was a favorite gem for lovers to give to their sweethearts, as the song intimates :

"'Tis redder than the rose is  
When first it bursts the bud ;  
'Tis brighter than the light is  
With all the east afood ;  
It tells her I would shed for her  
The last drop of my blood."

When a ruby exceptionally fine and of considerable size is to be worn in a finger ring, it will show to greatest advantage if set as a solitaire with as little gold as possible visible. Its beauty being beyond compare, it requires neither enhancement nor a foil.

Smaller rubies are set in a variety of ways, such as the central gem of a diamond cluster or a marquise ring. Many of the cross head or two stone rings employ a ruby in one of the overlapping ends and a diamond in the other. Very small rubies are of frequent occurrence in regard and name rings, also in the three hoop rings.

Ira D. Reidenbach, son of Squire A. B. Reidenbach, Lititz, Pa., was married last week, in Pittsburgh, Pa., to Miss Katharyne Beale. After the ceremony the couple left for Riverton, N. J., where the groom has a jewelry store.

**A Pleasing Announcement to the Whiting Mfg. Co.'s Employees.**

The employes of the Whiting Mfg. Co., New York, upon opening their wages envelopes, a few days ago, found a slip of paper upon which the following, which is a fac-simile of the original, was printed :

*We are glad to announce that the brighter outlook warrants the restoration of wages to former rates, and take pleasure in informing you that this change will take effect from this date.*

*Whiting Mfg. Co.*

*Nov. 15th, 1894.*

The announcement, it is almost unnecessary to say, brought happiness to almost 600 persons, forming the force of the Whiting Mfg. Co.

**Extension of the Plant of the Carborundum Co.**

MONONGAHELA CITY, Pa., Nov. 21.—The Carborundum Company are engaged in the erection of a new plant at Niagara Falls,

N. Y., consisting of five buildings, containing floor space of over 27,000 square feet. The buildings are substantial brick, iron truss, slate roofs, and will cost \$30,000. The company will use the power to be furnished by the Niagara Falls Power Co., and will begin operations with 1,000 electrical horse power, having an option on an additional

9,000, making it the largest plant of its kind in the world.

The demand for carborundum for jewelers' use has increased to such an extent that it has been found necessary to issue a special jewelers' list.

H. E. Adams, jeweler and optician, Sanford, Fla., has returned from a business trip of four weeks north, mostly in Philadelphia and New York.

**Jno. W. Reddall & Co**  
*A Stock more attractive than ever.  
 Replete with new and artistic conceptions in fourteen karat gold.*

MAKERS OF THE MOST POPULAR LINE OF  
 SILVER MOUNTED BRACES AND BELTS.

107 HAMILTON STREET,  
 Newark, N. J.



LEON C. SWEETLAND.

LOUIS I. SWEETLAND.

## SWEETLAND BROS.,

MANUFACTURERS OF **Jewelry Novelties,**

*NORTH ATTLEBORO, MASS.*

CORSAGE  
HAIR  
STICK  
HAT

# PINS



CZARINAS,  
COLLARETTES,  
WATCH POCKETS,  
LINK BUTTONS.

IN STERLING SILVER, PLATE AND ROMAN.

◆ ◆ ◆ NOVELTIES CONSTANTLY IN PREPARATION. ◆ ◆ ◆

## YOUR HOLIDAY TRADE

.. WILL REQUIRE ..

### Muff Holders.

**WE HAVE THEM!**

Prices range from \$12 to \$20 per dozen. All complete. Sterling Silver Mountings, Satin Ribbons, stylish and taking.

OUR LINE OF

**QUICK SELLING NOVELTIES**

INCLUDES

CZARINAS, BELTS,  
GARTERS, SUSPENDERS,  
BON BON SPOONS, Etc.

All in Sterling Silver. Write us!

**CODDING BROS. & HEILBORN,**  
NORTH ATTLEBORO, MASS.

NEW YORK OFFICE, CHICAGO OFFICE,  
C. A. Vanderbilt, 178 Broadway, F. A. Buck, 103 State St.



# Diamonds

.. AND ..

# Diamond Jewelry

.. FOR THE ..

## HOLIDAYS.

We have an unusually large stock of mounted goods all set in the latest designs of mountings and at prices that cannot be beaten.

We have imported a large reserve stock of Diamonds, and will not advance any of our prices at present. Dealers making their selections now will have the full advantage of the low tariff prevailing on Diamonds before the Wilson Bill went into effect.

You can save 15 per cent. by buying your Holiday Stock now.

If inconvenient to call upon us, or if you have a call for some special article not in your stock, let us send you a selection package.

## Cross & Beguelin

Loose—DIAMONDS—Mounted.

17 Maiden Lane,  
New York.

43 RUE MESLAY, PARIS.



## MAIDEN LANE OF THE PAST AND PRESENT.

BY MARY GAY HUMPHREYS.

IN one of Henry James' stories he says "the city of New York is like a tall sum in addition and the streets are like columns of figures." The most enthusiastic citizen will admit a want of imagination alike in First St. and One Hundred and Fifty-fifth, in Fifth Ave. and Avenue A. To these, however, are some notable exceptions, and Maiden Lane is chief.

A woman in the west who had never then been to this city once said that the association of her engagement ring with Maiden Lane gave her a distinct sensation of pleasure. It seemed fitting that the diamond sparkling in its white satin box should have come from a street so ideally named. She had afterward stood in this narrow busy thoroughfare, but nothing ever effaced that pleasant memory.

J Maadji Paatji, the Maidens' Path, as the Dutch called it, ran through Jan van Damen's farm. It was a shady umbrageous path through the valley. Along it the Dutch girls led their cows to the fresh water ponds. In the brook that tumbled between the sloping sides of the hills they held their washing carnivals, such as now

sociated with the domestic and homely social life of the town. There was a famous brewery of that day convenient to Pearl St., which was then Broadway and Fifth Ave. in one, and a lane led over to Crown St. When these pathways were dignified by city ordinance into streets, this lane became Cart and Horse St., and after the revolt of the colonies Crown St. became Liberty, and Cart and Horse was known, and ever since, as Gold St.

Some unexpected vein of sentiment in the aldermanic breast has preserved the name of Maiden Lane. This is rare good fortune, for after the city had grown into greater prominence through its misdemeanors and crimes, Maiden Lane had more than its share of ignominy to bear. The procession during the negro riots that ended in its barbarous butcheries marched through Maiden Lane.

One of the early entries of the Corporation of the City of New York, dated June 20, 1756, relates how on Thursday between the hours of nine and eleven, Mrs. Johanna Christiana Young and another lady, her associate, from Philadelphia, being found guilty of grand larceny at the Mayor's court are to be set on two chairs exalted on a cart, with their heads and faces uncovered and to be carted from the City Hall, past the old English Church, thence down Maiden Lane to Whitehall and the whipping post,

where each of them are to receive thirty-nine lashes, to remain in jail one week and then to depart the city.

There are several of such processions noted down Maiden Lane when it arrived at the dignity of a city street, not to mention the case of a lame old woman who having some words with a soldier, he raised his sword and cut her down the back. These stories contrast unhappily with the idyllic character of the earlier days of

Maiden Lane.

Meanwhile it was gathering importance and respectability. After the restoration of peace and the independence of the colonies, Maiden Lane reappears dedicated to commerce. Thither came the ladies from Pearl St. mansions to buy their laces and

tape. Madam Knight, a Boston lady who came to town like Macaroni, riding a pony, writes of them wearing "mutches, which are like a cap and headband in one, leaving the ears bare, and earrings and finger rings in abundance."



FROM MAIDEN LANE.

At this time we hear of no jewelers or goldsmiths on Maiden Lane, but of dealers in lead, steel and iron.

One wonders where was the shop of Simeon Sirimane. This is the first goldsmith mentioned in the colony. On March 23, 1727, John Stevens got up a lottery at Perth Amboy and Simeon Sirimane furnished the prizes. The first prize was an "8 square teapot"—note the "8 square" for octagonal—skimmer, sugar tongs and 6 teaspoons valued, it is interesting to note, at £18, 3s., 6d. The lowest prize was silver of 12 shillings in value. It is noteworthy that there were but five blanks. In lotteries at least, we have not profited over the colonial days.

The ladies of the colony, it is told by one of their historians, rarely wore gold chains. But they made up for this lack by the silver chains worn at their girdles and on their prayer-books. On these prayer-books was lavished much fine silver work. Mrs. Montgomery Schuyler has the prayer-book of Madame De Lancey. This is heavily bound in silver, ornamented at the corners, with a silver clasp bearing her name and coat-of-arms. A silver chain is added, by which it was carried hung over the arm.

One of the early records contains the sale of clothes and jewelry of Mrs. Dr. de Lange after her death. A black pendant, with



SCENE ON THE MAADJI PAATJI.

entertains us to see abroad. In the evening they walked under the trees with their swains. On the other side lay the rich clover pastures. These were laid out in streets, and Crown St., which we now know as Liberty, became an important thoroughfare, while the Maidens' Path was still as-

gold hooks, apparently being meant for ear-rings, brought 10s.; 1 gold boat attached to a white coral and diamond necklace, £16; 1 pair gold studs, with ten diamonds, £25; gold ring, with clasp back, 10s.; 1 gold hoop ring, with diamonds, £2 10s. One would like to have seen that white coral necklace, with diamonds, and a gold boat as a pendant.

In the early part of this century the goldsmiths got a footing in Maiden Lane. For now a period of 60 years they have held the street. To-day notwithstanding the march of business up town they are more strongly entrenched than ever. It is a curious inversion of the natural trend of affairs that the retail trade of Maiden Lane is greater than it ever was. As a commercial center Maiden Lane got its footing with retail shops. These followed the population up town. The jewelry trade began, one of the oldest dealers being authority for this statement, with jobbing houses. To these the manufacturers of Providence and other outlying places used to send their wares. The move of the manufacturers themselves on Maiden Lane was a subsequent development. The opening of retail shops by the manufacturers has followed their wholesale trade—a process of trade evolution that finds its parallel in no other business. In the natural development the gay and varied aspect of the retail shop leaves behind grim buildings and barren windows. But the jewelry and silver trade has been cunning enough to cling to the money-breeding

centers. The man flushed with the success of the day is in the mood to reward himself with a piece of luxury, or to carry home a

much broader is the range than in the jewelry displays uptown.

Maiden Lane may not rival the magnificence of the Rue de la Paix, but with that alone can it be compared in the concentration of one interest. But even the Rue de la Paix has not its unique features. These lie in its varied population, in the nature and diversity of the human tide that flows up and down its narrow channel day by day.

The banker and the office boy may have their noses pressed at the same glass window. The Jersey farmer and the opulent widow touch elbows. The typewriter and the rich westerner are fixed in silent admiration on the same glittering bauble. It is amusing to watch the detour of the street procession from window to window; boot-blacks, messenger boys, swagger young men, dignified old men, rich, poor, without distinctions of race, color, or sex, are moved by the same impulse down Maiden Lane. It is safe to say that probably no other street in the town has given birth to more generous emotions. No other street has prompted more self sacrifice. Of all articles of commerce



A FAMILIAR GROUP SEEN ON MAIDEN LANE.

jeweled trinket as a trophy to some one of his womankind. The opportunity for the exercise of this very human trait is offered freely in the tempting window shows of Maiden Lane and its neighbors. The discriminating observer will note how clever is the appeal to masculine tastes, and how

and art jewelry and silver suggest others. The rich man peering in the tempting windows of Maiden Lane finds his pleasure in fruition; the office boy gives himself up to the delights of hope. To each his own, and who shall decide which is the happier.

## THE CHINESE JEWELER AND HIS WORK.

*Wing Chiu Foo*

CHINESE women started the fashion of wearing jewelry, and the Chinamen have kept the ball rolling ever since, until even the Americans consider it a fashion. According to Chinese history their women wore rings and anklets ever since there was a Chinese woman, and that's before Mr. Noah was born. Seriously speaking the first Chinese jewelry store was started in the City of Chang On about 3 000 years ago, when Empress Wo Chi Tien (the only female tyrant China ever had) decorated herself and her court with its precious pearls and jades, and in turn decorated the enterprising jeweler with the "Yellow Jacket"

Jewelry was first worn by the women upon their ankles, later about their waists, around their necks, and finally at the

top of their heads; but the men beat the women one point by wearing jewelry upon the top of their hats, so that now a man's wealth in China is frequently measured by the amount of cost of the button on top of his official hat, which is always of coral. Some of these buttons cost as high as \$10,000 (so I was told.)

No Chinese woman is considered complete in her toilet unless at least she wears her earrings. No matter how poor she may be, she is expected to possess at least this much ornament. They are just as necessary as the conventional American girl's hair pins. (I don't mean curly or short haired girls.)

Girls as soon as they can toddle about must have their little pink ear lobes pierced to receive its allotted amount of jewelry,

without which they would be laughed at by their little playmates. The fashion of wearing clumsy anklets is still in vogue in a few of the southern provinces, notably the province of Kwong Tung where most of the American Chinese hail from. Some of these leg ornaments are very costly, being made of pure gold studded with expensive gems; more commonly they are only of twisted silver, or jade. These are large enough to go over the foot easily; when worn they give their owners much trouble in locomotion. This peculiar custom has long ago been abolished in northern China, where rings are only worn upon the fingers, and bracelets upon the wrists. The latter are as widely worn by men as by women, but they then differ in size and material, those of women.

# ★ ROGERS & BRO., A I.

## ORANGE SEASON....

### ORANGE KNIVES.



Pearl, Ivoride or Plated Handles,  
Cutting Edge, Saw Back Blades.  
*(A feature first introduced by us),* making  
a good all round Fruit Knife.

### ORANGE SPOONS.

- FLEMISH
- COLUMBIA
- SAVOY
- TUXEDO
- HARVARD
- YALE
- PRINCETON
- STOCKBRIDGE
- FLORIDA
- SHELL

PATTERNS.

Put up in sets of 6 in Plush Lined Boxes.

### ORANGE SETS.

1 Knife and 1 Spoon, or  
6 Knives and 6 Spoons.  
Put up in Plush Lined Boxes.

### ORANGE PEELERS.

..... POCKET OR TABLE SIZES.

### ORANGE HOLDERS.

Also a Large Line of Fancy Pieces put up in Beautiful  
Plush Lined Boxes. Suitable for the Holiday Trade.

FLEMISH ORANGE SET, No. 5.



# ROGERS & BROTHER,

16 Cortlandt St., New York.  
WATERBURY, CONN.

THE OLDEST MANUFACTURERS OF ROGERS' GOODS IN EXISTENCE.

# A MODEL FACTORY BUILDING.

THE KENT & STANLEY CO.'S MAMMOTH NEW STRUCTURE, THE  
FINEST OF ITS KIND IN THE WORLD.

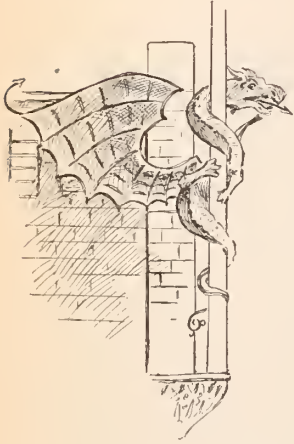

**P**ROMINENT among the many handsome factory buildings for which Providence is noted is the handsome structure built and occupied by the Kent & Stanley Co., on the Square bounded by Sabin, Aborn, Beverly and Mason Sts., in that

city. The property which it occupies was the location of the old-time popular skating rink, destroyed by fire last year. Mr. Edwin F. Kent, recognizing the advantages of the site, on his own responsibility purchased the property after the fire, though at that time the building occupied by the Kent & Stanley Co., at Eddy and Fountain Sts., was generally looked upon as a model factory, excellently planned and perfectly equipped.

Mr. Kent's foresight in the matter of the purchase of the new site was soon endorsed by his partners. Its proximity to the new railroad depot, which will be one of, if indeed not the finest, in the country is a guarantee of increasing values in that section of the city, while the increased shop room was something rendered imperative by the firm's constantly increasing business.

Work on the new structure which is depicted in one of the illustrations in this article, was begun on November 1, 1893, and October 1, 1894, the company was operating in its new quarters.

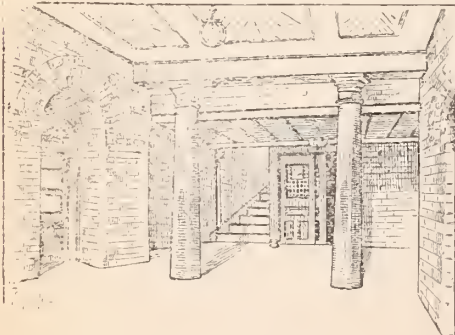

MAIN ENTRANCE ON SABIN ST.

The readers of the CIRCULAR can gather an idea of the immensity of the structure when it is borne in mind that it occupies an

acre of ground, rises seven stories above the foundation, has over 250,000 square feet of floor space, about 1,200 windows and required over five million bricks in its construction. While nearly all available space has already been leased, firms seeking modern quarters will do well to bear in mind that rentals are figured on a basis of 30 cents per square foot per annum, including power, steam heat water and elevator service.

The ground plan and character of the plot is excellently suited for the purpose to which it has been put. The L shaped formation gives it a frontage of 276 feet on Mason St., 221 feet on Aborn St., 106 feet on Sabin St., and 123 feet on Beverly St. A light well 40x200 feet extends from roof to basement in the main structure



THE KENT & STANLEY CO.'S BUILDING.

which with the additional advantage of four street frontages makes that great desideratum, good light, an assured fact for each tenant.

Red brick with brownstone trimmings was the material used for the walls, which rest on particularly solid foundations. At either corner on the Sabin St. facade are two handsome flag staffs held in place by artistic creations in wrought iron of dragons, one of which is incorporated in the initial letter beginning this article. Flags floating from these staffs bear, one, the company's trade mark on a white field and the other the national colors.

The two entrances to the building are well worthy of attention. Each shows a granite arch, while within enameled bricks of a light bluff tint please the eye and present an imperishable surface.

## THE KENT & STANLEY CO.

Our illustration shows the Sabin St. entrance with the handsome wrought iron elevator in the back ground, and two beautifully silvered supporting columns. The other entrance on Beverly St. is practically the same. Marble slabs for the names of the tenants is another feature not usually found in a factory building, and rapid running passenger elevators at either entrance afford quick access to, or egress from any floor. In the driveway running through from Sabin to Mason Sts., are two commodious freight elevators.

Floorings throughout are of maple, each floor being nearly an acre in area. The supporting columns are of iron, rising thirteen feet to the ceilings. Grinnell sprinklers and all other modern factory conveniences make the building a perfect one, whether from the view of the tenant, the insurance or the factory inspectors. Over 3,500 hands can find accommodation within its walls. Power and light are furnished by the company's private electric plant, one of the finest in the country.

The offices of the Kent & Stanley Co. are fitted up in oak, in the best taste, and pre-

sent an exceedingly attractive and handsome appearance. They occupy practically the whole of the Sabin St. wing on the sixth floor. Our illustration shows a view of the general office; adjoining it is the private office of Mr. E. F. Kent, which also connects with the director's suite.

The Kent & Stanley Co.'s shop, ever known as a model one, is in the new building better than ever. In one of the illustrations accompanying this article is shown a corner in the silver shop, a line in which the company is winning rapid recognition, and of which some of the productions, notably yachting trophies, have already been the subject of extended mention in the CIRCULAR.

A pioneer in selling its goods directly to the retail trade, the company, through its ten traveling salesmen and New York, Boston, Philadelphia and San Francisco offices offers a wide and varied line of goods. Some idea of its scope can be gathered from the fact that among them are:

**THE KENT & STANLEY CO.**

One-tenth and one-quarter Gold Seamless Wire Chains; Gents' Rolled Plate Vests, all Seamless Wire, 1, 2, 3, Strand Curbs; Dickens, Trace, Rope, Single Curb, Boston

**THE KENT & STANLEY CO.**

its predecessor, if that is possible. The business of the present Kent & Stanley Co. was first established in 1873 under the style of William H. Robinson & Co.,

**THE KENT & STANLEY CO.**

surviving partners, Edwin F. Kent and Arthur W. Stanley, under the old firm name. In 1887 these gentlemen purchased Mrs. Robinson's interest and continued under the style of Kent & Stanley. Under the new impetus, business during the two following years was doubled, but on Feb. 19, 1888, another fire once more interrupted operations by burning the factory entirely to the ground. Another shop was immediately found by Mr. Kent, and by noon of the day following the fire new machinery was already being put in position at the new shop, an instance of his indomitable will and prompt action in an emergency to which is due in a large measure the firm's success and high position to-day.

A lease of the ground on which the burned building had stood was quickly secured, and without the least unnecessary delay, Kent & Stanley began the erection of a building suitable to the needs of jewelry manufacturers which, when completed, ranked among the best factory buildings in the city. The firm took up its quarters in it and continued with increasing success. In February 1891, it was incorporated, under the title of the Kent & Stanley Co., being capitalized at \$300,000, represented in real property, and with charter rights for half a million. In November, 1893, the constantly increasing business necessitated larger quarters and the balance of the treasury stock was issued. In July, 1894, this additional stock had been issued, paid for in cash and invested in the new plant, which forms the subject of this article. It represents an investment of about \$350,000, and the total capital and surplus of the company in-



VIEW OF GENERAL OFFICE.

and Fancy Links; Red Gold and Platinum Links in all styles; Ladies' Lorgnette, Neck, Vest and Victoria Chains; 1,500 styles Gold, Silver and Plated Locketts and charms; White Stone Lace Pins and Brooches; Hair Ornaments; Chain Bracelets, Plate and Sterling Silver; Hat, Hair, Stick, Scarf and Bib Pins; Plated Sword Corsage Pins; Bracelet and Eye-Glass Chains.

In Sterling Silver Novelties, all warranted Sterling Silver are: Garters, Collarettes, Pocket Combs. Tie Holders; Belts with Silver, Pearl and Tortoise Shell Buckles, Paper Cutters and Weights, Match and Stamp Boxes, Trays, Letter Clips, Letter Openers, Book Marks, Prayer Book Marks, Thermometers and Calendars, Satchel Tags, Hat Marks, Coat Hangers, Souvenir Spoons, Umbrella Clasps, Pearl Teething Rings and Rattles, Glove Hooks, Button Hooks, Glove Stretchers, and Hat Buckles, Hair Pins in Celluloid, Real Tortoise Shell, Silver Mounted; Tooth Brushes, Shoe Horns and Letter Seals, Mirrors, Game Counters, Cigarette Cases, Sword Corsage Pins, Key Ring Chains, Bonbon Spoons, Pocket Knives, Scissors, Razors, Manicure Articles, Gold and Silver Mounted Suspenders, Novelties in Leather Card Cases, Memorandum Books, etc.; Stag Handle Cutlery Novelties, Corkscrews and many others.

The company issued last year one of the finest illustrated catalogues ever put out by a jewelry house and another is now in preparation which will be even better than

at 25 Calendar St. and the output consisted of chains. In 1882 Mr. Edwin F. Kent became a member of the firm and at once took an active interest in its welfare. In 1884 occurred the disastrous fire still remembered by the citizens of Providence, in

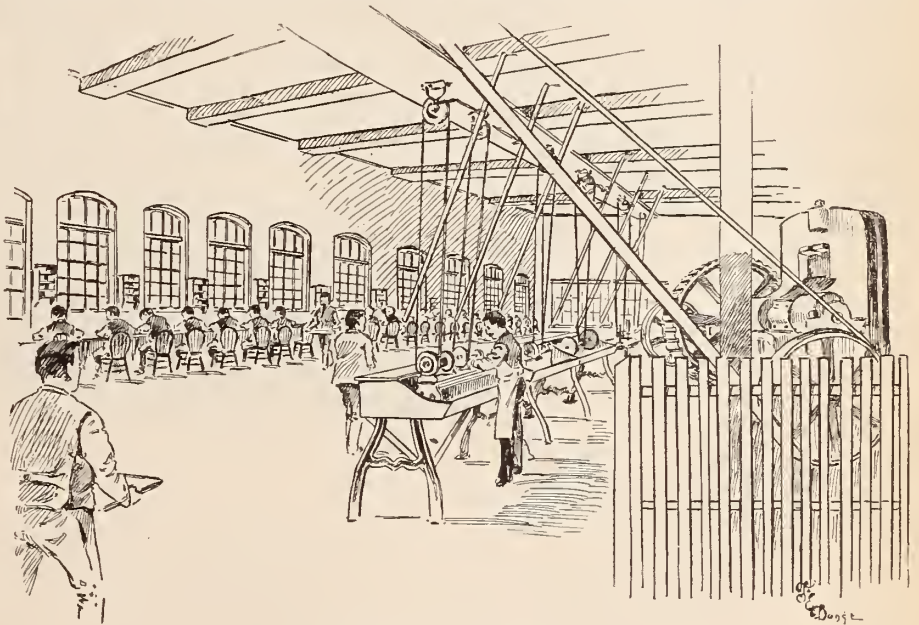

A CORNER IN THE SILVER SHOP.

which the factory was destroyed. New quarters were found at 7 Eddy St., and operations were again resumed. In 1885 Mr. Robinson died, and for nearly two years the business was conducted by the

vested in business is \$650,000. Its officers are: president, A. W. Stanley; treasurer, E. F. Kent; vice-president, J. S. Ingalls; secretary, J. D. Warren. George R. Clarke is superintendent and designer.



# Foster & Bailey,

MANUFACTURING JEWELERS AND SILVERSMITHS,

100 Richmond St., Providence, R. I.



**S**TERLING SILVER  
**S** MANICURE SETS,

925-1000 Fine,

With Shoe Horn and Shoe Buttoner.

MADE OF THE BEST STEEL PARTS.

Pul up in Fine Leather Roll, Lined with Dark Green Velvet and Having Beautiful Silk Flaps to fold over.

When Rolled Up it is Soft, Pliable, and Just the Thing to Pack in a Grip.

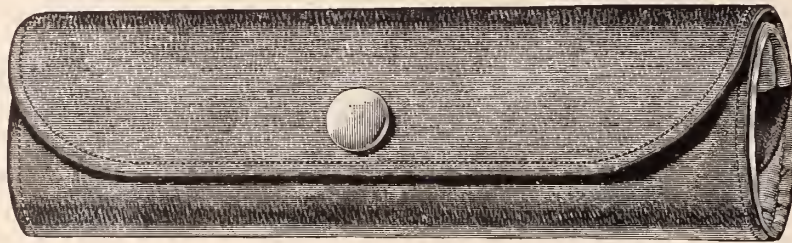

SET ROLLED UP—REDUCED ONE HALF EACH WAY.

Manicure Goods, Emery Strawberries, Pen Wipers, Garters, Paper Cutters, Pocket Combs, Match Boxes, Knives, Embroidery Scissors, Collarettes, Seals, Key Rings and Chains, Shoe Buttoners and Glove Buttoners, and lots of other nice things,

Rolled Plate Watch Chains, 1-10 Gold Vest and Dickens Chain, Chain Mountings, "Mount Hope" Buttons, Link Buttons, Locketts and Charms, Solid Gold Locketts, Bracelets, Neck Chains, Pins, Crosses, Earrings.

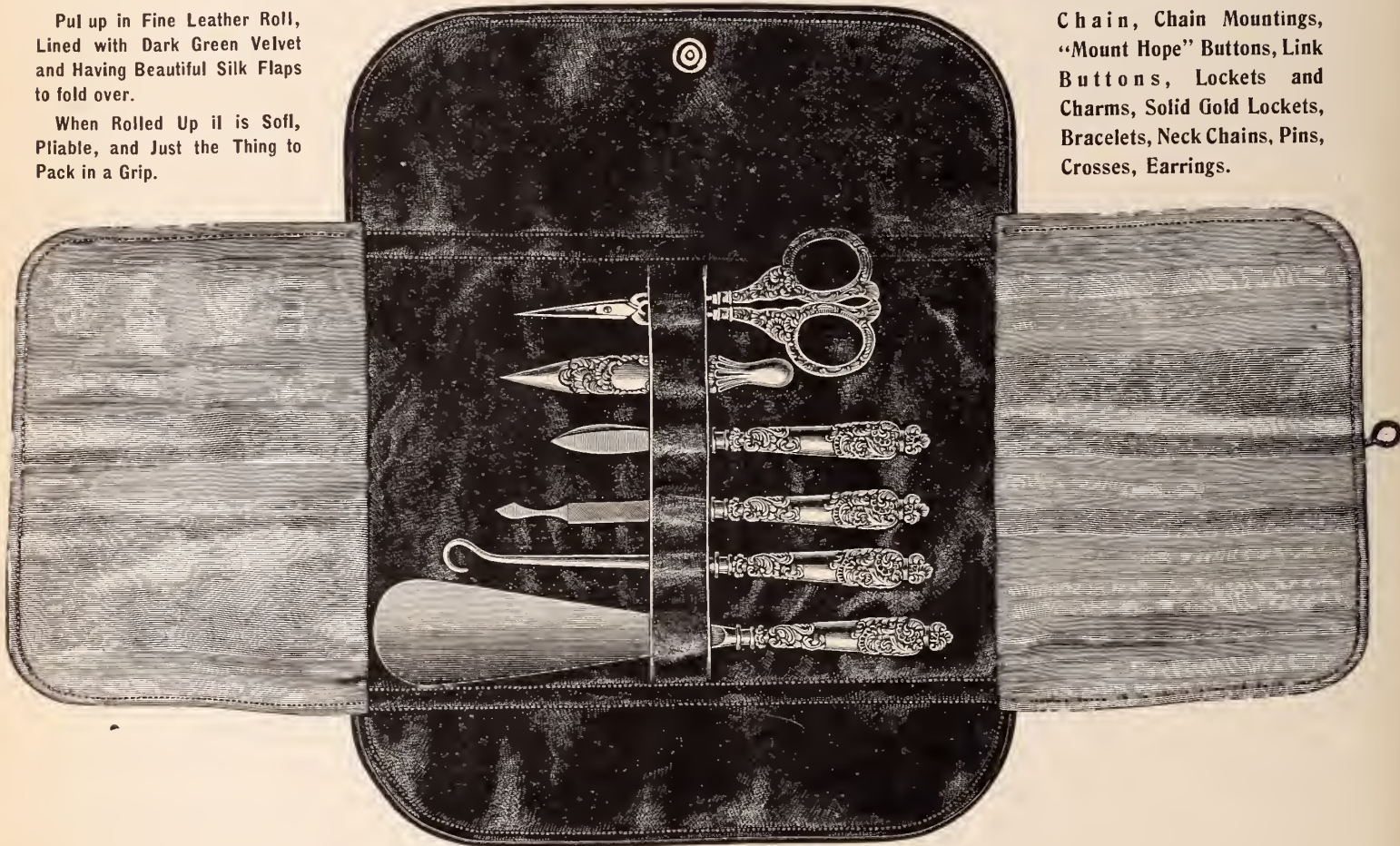

NO. 7 SET—REDUCED ONE HALF EACH WAY.

No. 138 File and Cuticle Knife Combined.  
" 139 Corn Knife.

No. 140 Button Hook.  
" 141 Shoe Horn.

No. 142 Nail Cleaner and Ear Spoon.  
" 143 Curved Scissors.

MANICURE SETS IN FINE KID CASES.

## STERLING SILVER SET No. 1, CONTAINS :

No. 54 = Tray.  
" 55 = Polisher Box.  
56 = Polisher.

No. 57 = = Paste Box.  
" 57 = = Powder Box.  
" 58 = = File.

No. 59 = Corn Knife.  
" 60 = Cuticle Knife.  
" 61 = Short Scissors

No. 70 = Long Scissors.  
Box.

No. 2 and No. 3 also in Sterling Silver, with less pieces, therefore cheaper in price. Nos. 4, 5 and 6 are in 1-10 Gold. All parts can be ordered separately, and all steel is of the best.

being more delicate and being of silver or gold, while the bracelets of the men are invariably of jade or a species of rare rattan. This jewelry is worn more because of a national superstition, than as ornaments, either as a talisman of good luck or as a cure for rheumatism.

Diamonds as jewelry are not yet as fashionable among the Chinese as jade, pearls, ruby, coral, silver and gold. Pearls and jades are the most popular. When describing one's wealth the Chinese do not say he is covered with "glittering diamonds," but with "jades and pearls."

The most exalted artisans of China are the jewelers and carpenters, one of the most formidable organizations of the trades union in the world being that of the Jeweler's Brotherhood of China, which claims a membership of several millions. Every member must be an expert metal worker of some sort. All Chinese jewelers are selected from childhood for their neatness in appearance as well as their natural adaptation for the skill of a mechanic. Then they serve a seven years' apprenticeship; the first three years they must pay to their masters for the privilege of giving their services to him.

The most expensive jewelry is worn upon the head of the Chinese ladies, instead of neck and hands as is the custom of Europeans. As the Chinese thoroughly believe the hair is a woman's glory, all endeavors are exercised to beautify it. The style of hair-dressing of the women of the Middle Provinces has long been conceded even by American tourists to be the most beautiful and artistic in the world; and the amount of small but expensive jewelry they manage to put into their jet black hair makes even an old maid attractive. The fashionable and fastidious girl has no less than 72 pieces of jewelry in her hair alone, and every piece has its distinct name and place. Their positions upon the head are so exact that a lady of fashion would instantly detect when one of the 72 pieces is stuck in the wrong portion of the hair.

Rings of all colors and styles are worn by ladies of the upper classes only. Poor and humble females are laughed at as vain when they make any such attempt. As a rule men never wear rings upon their hands except they be Chinese dudes. Then, they get a ring big enough to go upon their thumb. This is the only way they wear rings.

### AUTUMN COLORS.

One great glory of broad gold pieces appears the aspen,  
And the jewels of gold that were hung in the hair of  
the birch tree.  
Pendulous here and there, her coronet, necklace and  
ear-rings,  
Cover her now, o'er and o'er; she is weary and scatters  
them from her.

ARTHUR HUGH CLOUGH.

A silver lining in your pocket is more encouraging than one in the clouds.—*Puck*.



Reproduced from the English Illustrated Magazine.

### THE BRACELET TO JULIA.

Why I tie about thy wrist,  
Julia, this my silken twist?  
For what other reason is't,  
But to show thee how in part  
Thou my pretty captive art?  
But thy bond-slave is my heart;

'Tis but silk that bindeth thee,  
Snap the thread and thou art free  
But 'tis otherwise with me;  
I am bound, and fast bound so,  
That from thee I cannot go;  
If I could, I would not so.—HERRICK.

### HERE AND THERE A JEST.

MISS ROSEBUD—"Why is it they put a diamond in the engagement ring and none in the wedding ring?"

OLD CYNIC—"Because all the glitter ends with the marriage."—*Philadelphia Record*.

VISITOR—Have you any watch-dogs here?

JOHNNY SUBURB—No'm; but we've got some alarm-clock roosters.—*Street & Smith's Good News*]

"There was a lovely lot of fellows down at the beach," said Jeanette.

"Why didn't you come home engaged, then?" asked her friend.

"I did; that's my engagement ring."

"Why, my dear, just let me congratulate you. Which of the men is it?"

"It's all of 'm. They clubbed together and bought this solitaire."—*Harper's Bazar*.

# TOWLE

Manufacturing Company,

SILVERSMITHS,

Newburyport,

MASS.

CHICAGO,

149 & 151 STATE STREET.

REVERSE.

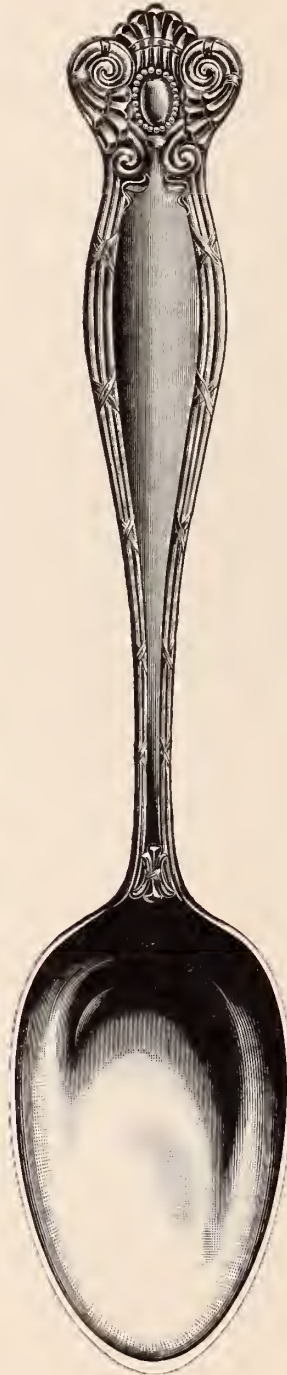
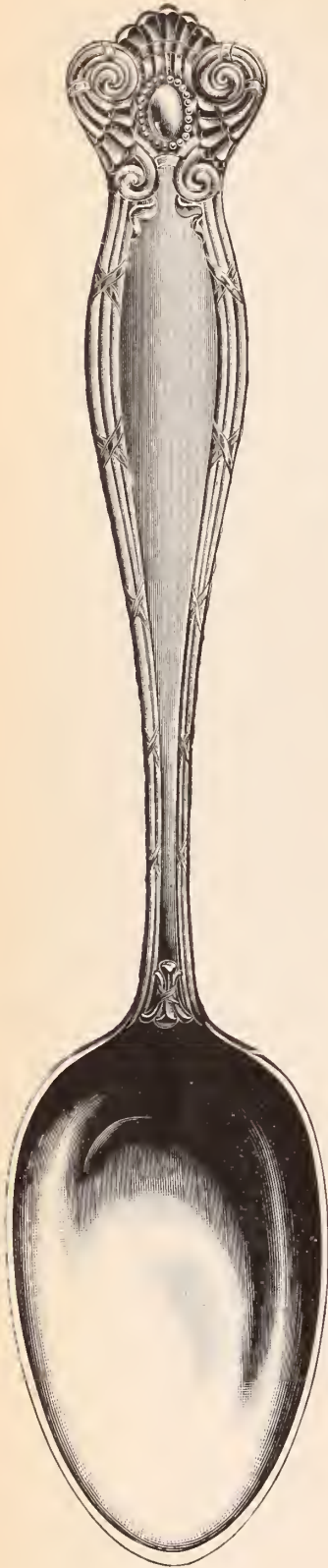

# EMPIRE . . .

In substantial weights for durable table service.





## CHRISTMAS POETRY AS AN ADVERTISEMENT.

THERE is, indeed, no new thing under the sun. The Christmas poem, employed as an advertisement, was in use over a quarter of a century ago. A very curious example of it is called "Annie and Willie's Prayer." It was used as a hand-bill by Garret T. Dorland, jeweler, who, in those days, had a famous store at the northwest corner of 5th and Main Sts., Cincinnati, O. One copy of this curious old bill still exists.

The poem is introduced in the original bill thus: "The following poem, written by Mrs. Sophia P. Snow, is one of the most exquisitely touching and beautiful that we ever read. It cannot fail to reach the hearts of all who peruse it, besides being peculiarly appropriate to the holidays."

At the end of the poem is the jeweler's advertisement setting forth a list of this, that and the other, "suitable for all dear little darlings, wives, mothers, sisters, brothers, sweethearts." The text of the poem is as follows:

'Twas the eve before Christmas; "good night" had been said,  
 And Annie and Willie had crept into bed;  
 There were tears on their pillows, and tears in their eyes.  
 And each little bosom was heavy with sighs—  
 For to-night their stern father's command had been given  
 That they should retire precisely at seven,  
 Instead of eight; for they troubled him more  
 With questions unheard of than ever before;  
 He had told them he thought this delusion a sin,  
 No such being as "Santa Claus" ever had been,  
 And he hoped, after this, he should never more hear  
 How he scrambled down chimneys with presents each year.  
 And this was the reason that two little heads  
 So restlessly tossed on their soft, downy beds  
 Eight, nine, and the clock on the steeple tolled ten;  
 Not a word had been spoken by either till then.  
 When Willie's sad face from the blanket did peep,  
 And whispered, "Dear Annie, is you fast asleep?"  
 "Why, no, Brother Willie," a sweet voice replies,  
 "I've tried it in vain, but I can't shut my eyes;  
 For somehow, it makes me so sorry, because  
 Dear papa has said there is no Santa Claus;  
 Now we know there is, and it can't be denied,  
 For he came every year before mamma died.  
 But then, I've been thinking that she used to pray,  
 And God would hear everything mamma would say,  
 And perhaps she asked Him to send Santa Claus here  
 With the sacks full of presents he brought every year."  
 "Well, why tan't we pay dest as mamma did then,  
 And ask Him to send him with presents aden?"  
 "I've been thinking so, too," and without a word more  
 Four little bare feet bounded out on the floor.  
 And four little knees the soft carpet pressed,  
 And two tiny hands were clasped to each breast;

"Now, Willie, you know you must firmly believe  
 That the presents we ask for we're sure to receive;  
 You must wait just as still 'till I say the 'Amen,'  
 And by that you will know that your turn has come then.

Dear Jesus, look down on my brother and me,  
 And grant us the favor we are asking of Thee.  
 I want a wax dolly, a tea set and ring.  
 And an ebony work-box 'that shuts with a spring;  
 Bless papa, dear Jesus, and cause him to see  
 That Santa Claus loves us far better than he.  
 Don't let him get fretful and angry again  
 At dear brother Willie and Annie, Amen!"  
 "Please, Desus, 'et Santa Taus tum down to night  
 And bring us some presents before it is light.  
 I want he should dive me a nice little sled,  
 With bright shiny runners and all painted yed;  
 A box full of tandy, a book and a toy.  
 Amen, and then, Desus, I'll be a good boy."  
 Their prayers being ended, they raised up their heads,  
 And with hearts light and cheerful, again sought their beds;  
 They were soon lost in slumber, both peaceful and deep,

And with fairies in Dreamland were roaming in sleep,  
 Eight, nine, and the little French clock had struck ten,

Ere the father had thought of his children again.  
 He seems now to hear Annie's half suppressed sigh  
 And to see the big tears stand in Willie's blue eyes.  
 "I was harsh with my darlings," he mentally said,  
 "And should not have sent them so early to bed;  
 But when I was troubled my feelings found vent,  
 For bank stock to-day has gone down 10 per cent.  
 But, of course, they've forgot their troubles ere this;  
 And then I denied them the thrice-asked-for kiss;  
 But, just to make sure, I'll steal up to their door,  
 For I never spoke harsh to my darlings before."  
 So saying, he softly ascended the stairs,  
 And arrived at the door to hear both of their prayers.  
 His Annie's "bless papa" draws forth the big tears,  
 And Willie's grave promise falls sweet on his ears.  
 "Strange, strange I'd forgotten," said he with a sigh,  
 "How I longed, when a child, to have Christmas draw nigh."

"I'll atone for my harshness," he inwardly said,  
 "By answering their prayers ere I sleep in my bed."  
 Then he turned to the stairs and softly went down.  
 Threw off velvet slippers and silk dressing gown—  
 Donned hat, coat and boots, and was out on the street,  
 A millionaire facing the cold, driving sleet.  
 Nor stopped he until he had bought everything,  
 From the box full of candy to the tiny gold ring.  
 Indeed, he kept adding so much to his store,  
 That the various presents outnumbered a score.  
 Then homeward he turned with his holiday load,  
 And, with Aunt Mary's aid in the nursery, 'twas stowed;

Miss Dolly was seated beneath a pine tree,  
 By the side of a table spread out for her tea;  
 A workbox, well filled in the center was laid,  
 And on it a ring for which Annie had prayed.  
 A soldier in uniform stood by a sled,  
 "With bright shining runners and all painted red."  
 There were balls, dogs and horses, books pleasing to see,  
 And birds of all colors were perched in the tree;

While Santa Claus, laughing, stood up on the top,  
 As if getting ready more presents to drop.  
 And as the fond father the picture surveyed,  
 He thought for his trouble he had amply been paid.  
 And he said to himself, as he brushed off a tear,  
 "I'm happier to-night than I've been for a year.  
 I've enjoyed more true pleasure than ever before,  
 What care I if bank stock falls 10 per cent. more!  
 Hereafter I'll make it a rule, I believe,  
 To have Santa Claus visit us each hristmas Eve."  
 So thinking he gently extinguished the light,  
 And tripped down the stairs to retire for the night.  
 As soon as the beams of the bright morning sun  
 Put the darkness to flight, and the stars, one by one,  
 Four little blue eyes out of sleep opened wide,  
 And at the same moment the presents espied;  
 Then out of their beds they sprang with a bound,  
 And the very gifts prayed for were all of them found.  
 They laughed and they cried in their innocent glee,  
 And shouted for "papa" to come quick and see  
 What presents old Santa laus brought in the night,  
 (Just the things that they wanted) and left before light.

About a year ago C. C. Paule, Burlington, Ia., offered a diamond ring to the scholar composing the best poem on the subject of the Paule's jewelry store. The first prize was awarded to the author of the following:

### A LOOK IN PAULE'S STORE.

At Four Hundred and Five on Jefferson Street,  
 A store is found to which the feet  
 Of scores of people do daily haste,  
 To view the riches of art and taste.

The windows are wide and high and deep,  
 Wherein are shown wares rich and cheap;  
 And mirrored sides the scenes repeat,  
 To charm the eye; to buy, entreat.

The walls within enchanting beauty hold;  
 And clocks of pattern attractive and new,  
 With chimes of cathedral, and song of cuckoo.

On shelving high, the eye still glancing,  
 Scans wares with polished beauty dancing;  
 Tea sets and pitchers in form symmetric,  
 Reflecting back the light electric.

In bordering cases on either hand,  
 Are rings and pins, and jeweled watches grand;  
 Pearls and rubies encircled by diamond rays,  
 For maidens to envy, and matrons to praise.

With mirrored aid the scene's extended,  
 The Real, into the picture's blended;  
 Ah me! could dollars thus be multiplied,  
 I'd buy these gems for Christmas-tide.

All lands pay tribute to this place,  
 A veritable, royal jewel case;  
 'Bove all's a Moorish fret work screen,  
 Where . . . PAULE'S name is seen.

Burglars carried away 60 watches from the jewelry store of C. W. Garwood, Urbana, Ill., recently.

### Proceedings of the American Horological Society.

CHICAGO, Ill., Nov. 23.—The regular monthly meeting of the society was held on Nov. 12, President Parsons presiding. The applications of A. Wedeking and Joseph Bachmer, Chicago, and O. P. Memhard, Spokane, Wash., having been approved, they were duly elected to membership. Notice having been given of a proposed change in the constitution and by-laws, to the effect that on and after Nov. 12 all meetings of the society will be held on the second Wednesday evening of each month, instead of the second Monday evening, the motion was carried unanimously.

On motion, unanimously carried, the secretary was instructed to serve notice on all members in arrears for dues for one year or more, to appear at the next regular meeting and show cause why they shall not be suspended for non-payment of dues, according to the constitution and by-laws.

A number of applications have been received from watchmakers who desired to be examined, with a view of securing the society's certificate, and the necessary blanks are ready and the judges commenced examinations by sending out the questions on Nov. 21. Applications for examination can be secured by addressing the secretary.

On motion of J. H. Purdy, carried unanimously, it was resolved that hereafter the "Question Box" of the society be opened to the trade at large, and the members of the society will discuss at the regular meetings and answer to the best of their ability all questions of a practical nature that may be submitted, and the questions and answers will be given to the trade papers for publication if they so desire. All questions are to be mailed to the secretary, and must bear the writer's full name and address. A *nom de plume* or initials may be used, however, where the writer wishes his name withheld, but his full name must also accompany the question.

The question selected for the discussion of the evening was:

"What is a good rule for determining the strength of hair springs?"—W. S. B., Cordele, Ga.

A. W. Johanson said that he made it a rule to first ascertain whether the watch was a fast or slow train, *i. e.*, 18,000 or less vibrations an hour. In most cases it was found that it beat 300 per minute, or 18,000 per hour, but, occasionally, a slow train was met with still. To ascertain the beat, proceed as follows: Count the teeth in the fourth wheel, where the watch has a second hand, and divide by the number of leaves in the escape pinion. For example, there are 60 teeth in the fourth wheel, divided by 6, the number of leaves in the scape pinion, equals 10, or there are ten revolutions of the escape pinion to one of the fourth wheel. Now multiply this result by double the number of teeth in the escape wheel. Teeth in escape wheel,  $15 \times 2 = 30 \times 10 = 300$ , the number of vibrations per minute, and  $300 \times 60 = 18,000$  the vibrations per hour. In slow trains, we find 63 teeth in fourth wheel and 7-in. escape pinion, and we then proceed as before:  $63 \div 7 = 9 \times 30 = 270 \times 60 = 16,200$  beats per hour. Having determined the number of beats, he determined the strength of the spring approximately, by setting one at random and trying it. To do this, hang the balance on the end of spring, and if it covers the spring about one half the diameter of the balance, or a little less, it is approximately right. He then held the inner end of spring between the collet and balance and the outer end in the tweezers and moved the tweezers in or out as the case demanded, until the requisite number of beats was secured.

### The C. Preusser Jewelry Co. Celebrate Their Semi-Centennial.

MILWAUKEE, Wis., Nov. 21.—Fifty years ago yesterday, Christian Preusser first opened his jewelry store in Milwaukee, and his many friends among Milwaukee's foremost citizens called on him at the elegant store of the C. Preusser Jewelry Co. to express their heartfelt congratulations.

During his 50 years' residence in Milwaukee Mr. Preusser has been identified with the business and educational progress of the city. He was one of the founders of the German-English academy of this city, and what is now the public museum. He was also one of the founders of the German

Teachers' Seminary, and has long been a member of the Milwaukee Mechanics' Fire Insurance Co., being in fact, one of the incorporators. Mr. Preusser has been successful in everything he has undertaken, and is accounted one of Milwaukee's wealthiest business men.

The Preusser jewelry store was established on the site of the present Kirby House, or rather just where the Kirby House barber shop is now located. The jewelry store was in a dwelling which, by a partition, was divided into two stores, one occupied by Mr. Preusser and the other being used as a shoe shop. Mr. Preusser was 18 years old when he came to Milwaukee and opened the business. He was born in Itzstein, Nassau, in 1826. He came to America in the Summer of 1844, with the family of the late Philip Best, landing in New York in July. From New York Mr. Preusser went direct to Detroit, where he joined his brother, Gustav Preusser, and the two then came to Milwaukee, landing here in October, 1844. Nov. 20, 1844, the Preusser jewelry store was opened on E. Water St.

In 1847 Mr. Preusser bought the two lots at the northeast corner of Mason and Market Sts., where the store is now located. On the lots he erected two frame buildings, the building at the corner being occupied by the jewelry store. In 1855 the two frame buildings were torn down and made way for the present brick building. For many years the jewelry and watch business was confined to a narrow space at the corner, and in 1890 the store was remodeled and extended, and now is one of the finest stores of its kind in the northwest.

In 1858 Mr. Preusser took into partnership his brother, Gustav Preusser. In 1887 the Preusser jewelry business was organized into a stock company, under the name of the C. Preusser Jewelry Co., the members of Mr. Preusser's family becoming stockholders.

### Sale of a Notable Collection of Jewels.

SAN FRANCISCO, Cal., Nov. 20.—During the past week the trustees of Mary's Help Hospital have been selling at auction, the marbles, bronzes, porcelains, jewels, rugs and carvings of the late Mrs. Kate Johnson,

DIAMOND CUTTERS and POLISHERS looking for desirable and permanent positions should apply direct to

**FOX BROS. & CO.,**

68 and 70 West 4th Street,

CINCINNATI, OHIO.

which had been bestowed by her will for a perpetual benefit of the institution. The prices obtained were not entirely satisfactory, and local dealers made many safe investments.

Loose corals, ordinarily salable for \$25 and \$30, went for \$3.50. Twenty-eight old watches, which cost \$750, were knocked down to a dealer for \$130. The lively bidding came on the finer jewelry and gems. A pair of cuff buttons, containing 16 diamonds set in polished onyx, for which Mrs. Johnson paid \$800, went to Jeweler Greenbaum for \$185. Col. Andrews paid \$230 for a \$500 diamond ring, and \$210 for another containing one large black diamond, a large and two small white ones. A wonderful set of pin and ear-rings of enormous moonstones surrounded by diamonds, valued at \$1,275, went to Mrs. Dingee for \$610.

Col. Andrews secured the collection of solitaire diamonds for \$1,020 and Mrs. Johnson had paid \$3,750 for them. The famous Empress Eugenie necklace of seventeen square cut diamonds, variously valued at from \$3,400 to \$4,000, went to Col. Andrews for \$950.

A \$2,000 clock brought \$250 and mantel clocks, silver sets, ivory carvings, and in fact every article in the great collection sold at about the same proportionate price.

Beardsley & Staples, Hamburg, N. Y., have dissolved partnership. Mr. Beardsley will carry on the business.



# A. WITTNAUER,



Successor to J. EUGENE ROBERT & CO.,

19 MAIDEN LANE, - - NEW YORK.

## Swiss Watches and Movements

—OF—

ALL DESCRIPTIONS, STYLES AND SIZES

—AND—

IN VARIOUS GRADES.

### SPLIT SECONDS, MINUTE REPEATERS AND NOVELTIES.

## Entirely New Cloak Clasps.



Made in Heavy  
Sterling Silver in  
many designs.  
All sizes.  
All Prices.



### Ebony Goods

The most artistic that have ever been shown.

We have produced the most elaborate line of Foilet and Manicure Articles on the market. These goods are mounted with Pierced Sterling Silver, artistically engraved. Also a line of Sterling Silver Pocket and Paper Knives, Scissors, Pen Wipers, Hair Pins, Filigree Coffee and Tea Spoons, Key Rings, Garter and Belt Buckles, Baby Rattles, Ink Stands, Curling Sets, Paper Files, &c. Also great variety of

Silver Mounted Pipes, Sterling Silver Scissors and Knives at low prices.

PHOTO FRAMES IN EBONY AND STERLING SILVER.

MANUFACTURER OF

# J. N. Provenzano,

## RICH JEWELRY AND SILVER NOVELTIES.

39 UNION SQUARE, NEW YORK,



**SOMETHING NEW !**

**Interchangeable Initial Watches.**

We have placed on the market a line of "Charmilles" watches cased in steel, black oxydized with GOLD INITIALS in relief. These initials are interchangeable with the backs; are 10 karat gold, cost but little extra, and make

**A VERY ATTRACTIVE WATCH.**

INITIAL watches appeal to public sentiment and taste. The advantages of INTERCHANGEABLE Initial Watches at LOW PRICES will be appreciated by all.

Ask Your Jobber For Them.

A. C. SMITH WATCH CO., - 177 Broadway, New York.

**MANICURE GOODS**

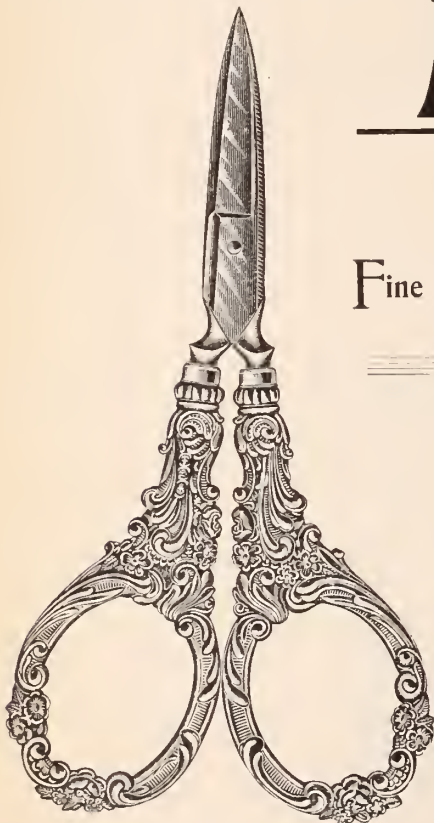

"THE PRINCESS."

Fine Cut Glass  
**SCISSORS.**

Mounted in Sterling Silver, Large and Varied Assortment of Patterns and Sizes.

We are showing Complete Lines of Sterling Silver Mounted

In an Endless variety of  
NEW AND EXCLUSIVE DESIGNS.

Royal  
Silver  
Novelty  
Co.,  
Silversmiths

470 Broadway,  
... NEW YORK.

The Cutest, Quickest  
Selling Novelty of  
the Season.



THE MIDGET.

**SCISSORS.**

Fountain Pen 14 Kt. Solid Gold Nib



**\$7.50**  
DOZ.

Net Cash  
with Order.

Elegant Plush Lined Box FREE. Every Pen Warranted. Send for Catalogue.

**DIAMOND POINT PEN COMPANY, 7 Astor House (Broadway), New York.**

### William H. Hansell Unsuccessfully Tries to Get Goods in New York.

William H. Hansell, a former jeweler of Philadelphia, Pa., who, as stated in THE CIRCULAR, Nov. 14th, was arrested in that city on the charge of obtaining goods from Geo. W. Russell and other jewelers by means of worthless checks, was in New York last week attempting to buy goods. The dispatch from Philadelphia stated that Hansell's counsel put in a plea that his client was of unsound mind, and that on his friends' statement that they would take care of him Hansell was released from custody. Some members of the trade in New York who had read this were surprised by receiving a visit from Hansell during the latter part of last week.

Among the firms on whom Mr. Hansell called were Hodenpyl & Sons, 170 Broadway, E. Aug. Neresheimer & Co., 20 Maiden Lane, H. C. Hardy & Co., 12 Maiden Lane, Jos. Frankel's Sons, Sheldon building, E. Ira Richards & Co. and Stern Bros. & Co., also in the same building, and Ludeke & Power, 23 John St. From all but E. Ira Richards & Co., Hansell attempted to obtain diamonds on credit. Owing to the fact that his Philadelphia episode was generally known and that the New York Jewelers' Board of Trade had sent out word warning dealers not to sell him, Hansell obtained no goods from them.

Mr. Hansell made the following statement to a CIRCULAR reporter Saturday, in explanation of his arrest: "Before issuing the checks, I consulted my friend, District Attorney Graham, of Philadelphia, and asked him if it would be illegal to issue checks for more than I had in the bank; he said no, provided I made the amount good within a few days. This I intended to do and was, therefore, greatly surprised at my arrest. I had orders for all the goods I bought, and expected to sell them and deposit the money for the checks. I was forced to do this because I was unable to get credit. In all I got about \$1,500 worth of goods. My bank balance was about \$100. After I was arrested I returned all the goods and the charges were not pressed. Since then I've inherited about \$10,000, and intend to go into the diamond business as soon as I can buy some goods."

Wm. H. Hansell was employed by Butler, McCarty & Co. and started in business in Philadelphia about 20 years ago as Hansell & Suddards. This firm, which dissolved in 1877, was at one time favorably regarded in the trade. Since that time Hansell continued alone in a small way.

### No Technical Charge of Embezzlement Against Thomas Pendergast.

LANCASTER, Pa., Nov. 24.—The trial of Thomas Pendergast, proprietor of the American Horological Institute, of this city, on the charge of embezzlement, was begun yesterday and concluded this morning, the jury rendering a verdict of not guilty.

The prosecutor was C. H. Specht, of

Huntingdon, Pa., who testified that he sent \$210 worth of tools and watch materials to Pendergast with the understanding that the latter was to sell them and remit the proceeds. The goods were sold by Pendergast, but Specht received no money. The general opinion was that the technical charge of embezzlement had not been made out. The grand jury this week ignored another charge of embezzlement against Pendergast in which W. W. Appel, jeweler, of this city, was the prosecutor.

Robert E. Locher, of this city, on Tuesday issued an execution for \$163 against Thomas Pendergast.

### The Mysterious Drowning of M. G. Linsley.

CHICAGO, Ill., Nov. 24.—Wednesday morning a laborer passing the foot of 98th St. on the lake shore discovered a body floating on the lake. The corpse was drawn upon the beach and an examination showed it to be that of M. G. Linsley, the well known diamond salesman for Hyman, Berg & Co. Mr. Linsley left the store the Friday evening previous in his usual good spirits. Saturday he sent word to the firm that he was ill. Monday Mr. Hyman thought of calling at the Hotel Metropole to inquire as to the salesman's health, but deferred, expecting his return the following day. Tuesday he did not report for duty, and Wednesday came the startling news of his body being recovered from the lake.

Mr. Linsley was a genial, affable gentleman, moved in the best society and was held in high regard by all with whom he came in contact. His personal following was large. Coming to Chicago some ten years ago from Geo. H. Ford & Co., New Haven, Conn., he was for several years with Giles, Bro. & Co. and 18 months ago entered the employ of Hyman, Berg & Co. He had always been a high salaried man and had lived fully up to his income. Friends have kindly admonished him to look after the years that are to come but he seemed to regard the future lightly.

It is possible that a sense of what the future might have in store produced a temporary dementia which resulted in the taking of his life. Whatever the cause, there is no known sufficient reason for the deed. The body was forwarded Thursday night to his parents at Meriden, Conn., the coroner's jury having rendered a verdict of accidental death by drowning.

### The Death of Joseph Bevan.

BALTIMORE, Md., Nov. 23.—Joseph Bevan, Sr., died at 521 N. Carrollton Ave., yesterday morning, from gastric trouble, aged 79 years.

The deceased was born in this city, and had been engaged in the jewelry business all his life. He was in this business for 18 years in Williamsport, Pa., and for the past 10 years in Winston, N. C. He had been sick about three months. A wife and one son survive him.

# WE LEAD



## IN Royal Worcester.

### We Are Offering To-Day

Lines of shapes and decorations intended by the Royal Worcester Porcelain Company for next spring. We can sell you OUT OF STOCK goods which will be shown as novelties in February by other houses.

## LE BOUTILLIER & Co.,

### 860 BROADWAY,

### NEW YORK.

Northeast Corner of Seventeenth Street.

### Action to have Charles Seale's Assignment Set Aside.

Judge Beach in the New York Supreme Court Special Term, Wednesday, heard the arguments in the joint action brought by the Gorham Mfg. Co. and W. B. Durand, against Chas. Seale, formerly a jeweler at 20th St. and Broadway, who assigned May 31, 1893, to Edward B. La Fetra. The action was brought by the plaintiffs as judgment creditors to set aside the assignment on the ground that Seale had fraudulently concealed and disposed of property prior to his assignment. The plaintiffs introduced witnesses who testified that according to the books there was a discrepancy of \$80,000 in the assets and that 160 articles valued at \$18,000 were unaccounted for. W. B. Durand testified that in December, 1892, Seale's stock which he then saw was in his opinion worth about \$100,000. Another witness testified that shortly before the failure he saw displayed in Seale's office stock worth \$25,000.

Seale's schedules filed June 29, 1893, showed liabilities of \$96,285 and actual assets of \$28,844. Of these the merchandise on hand was worth but \$2,030, while \$14,771 was the actual value of goods pledged as collateral and merchandise on consignment was nominally worth \$23,338, and actually valued at \$696.

Mr. Seale and his assignee, Mr. La Fetra, took the stand for the defence. They testified that the books showed no discrepan-

cies as the plaintiffs claimed and introduced the books in evidence. Judge Beach granted 15 days in which the counsel, Geo. C. Comstock, for the plaintiffs, and Jno. C. Robinson, for the defendants, are to hand up briefs.

### The Death of Charles Schuetz.

Charles Schuetz, formerly a member of the firm of Knoeller & Schuetz, manufacturers of diamond mountings, 61 Nassau St., New York, was buried Wednesday last at the New York Bay Cemetery. Mr. Schuetz died of apoplexy Nov. 18th, at his residence in Jersey City. He had been ailing for about two years.

Mr. Schuetz was born in New York, July 31st, 1844. He started in the jewelry business in 1857 as an apprentice. Later in 1857 he went with Bailey & Huntington, where, with his future partner, Jno. H. Knoeller, he completed his apprenticeship. The two latter became employed by Huntington & Earle, 15 John St., where they remained until 1877. Then with O. P. Ganter they started the firm of Knoeller, Schuetz & Ganter. Mr. Ganter retired in 1883 and Knoeller & Schuetz continued until September, 1892, when Mr. Schuetz retired.

Mr. Schuetz was a veteran of the late war, having served 14 months in the 1st N. J. Battery. He was a former member of the G. A. R., and a member of the Royal Arcanum.

### Bad Business Causes E. B. Schiller to Assign.

Eugene B. Schiller, dealer in plated jewelry and novelties, 415 Broadway, New York, made an assignment Thursday to Aaron Morris, lawyer, 235 Broadway, giving a preference of \$1,000 to Levy & Kadane.

Mr. Schiller was a retailer and did a small wholesale business. His assignee, Mr. Morris, stated to a CIRCULAR reporter Friday that the assignment was due to bad business and poor collections. His schedules, he said, would surely be filed some time this week. He could not say what the assets and liabilities were as he had not yet examined the books or stock. He believed that Mr. Schiller intended to call a meeting of his creditors just as soon as a complete statement could be made to them. The bulk of Mr. Schiller's indebtedness is to firms outside of New York city.

E. B. Schiller was formerly employed by J. J. Cohn whom he left to start in business for himself. On May 1, 1883 with Abraham Kadane he formed the firm of E. B. Schiller & Co. Since the dissolution of this firm, Mr. Schiller continued alone.

O. L. Rosenkrans, of the O. L. Rosenkrans & Thatcher Co., Milwaukee, Wis., is selling the old Weber Co. stock out at auction, in the store formerly occupied by the Weber Co., at the corner of Wisconsin and E. Water Sts.

## THE SOUL OF THE DIAMOND.

A PASTEL IN PROSE.

### I.

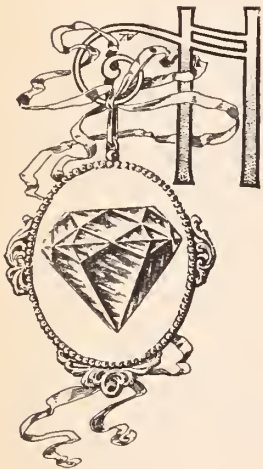

HUNDREDS of uncounted years it lies hidden from eye of man, enclosed in the baser mould in the bosom of Mother Earth, little dreaming that within its soul resides the quintessence of brilliancy and purity, and that man prizes it above all things of material value.



### II.

In the seeking for riches, after the prospector has discovered its lair, after organized labor has delved for it and unearthed it, from a nameless pebble it is a modicum of wealth, though in aspect but a dirty mite of quartz.

### III.

Traveling over the main, thousands of miles, it reaches the works of **OPPENHEIMER BROS. & VEITH, NEW YORK**, whose cutters and polishers lend their art, bringing forth its true nature and making it "a gem of purest ray serene," the superlative of beauty, the zenith of purity, emblem of riches, token of innocence.



# The Jewelers' Circular

AND  
HOROLOGICAL REVIEW.

PUBLISHED EVERY WEDNESDAY BY  
**THE JEWELERS' CIRCULAR PUB'G CO.,**  
189 BROADWAY, NEW YORK CITY.

A JOURNAL DEVOTED TO THE INTERESTS OF  
JEWELERS, WATCHMAKERS, SILVERSMITHS,  
ELECTRO-PLATE MANUFACTURERS, AND ALL  
ENGAGED IN KINDRED BRANCHES OF INDUSTRY.

Our Editorial columns will contain our own opinions only, and we shall present in other columns only what we consider of interest or value to our readers. Advertising matter will not be printed as news.

Advertising rates in THE CIRCULAR are lower considering the number of tradesmen reached by its large circulation, than in any other jewelry journal.

Notices of changes in standing advertisements must be received one week in advance; new matter can be received up to Monday.

## INFORMATION FOR SUBSCRIBERS.

### Terms of Subscription, Postage Prepaid.

	PER ANNUM
United States and Canada, . . .	\$2.00
Foreign Countries in Postal Union, -	4.00
Single Copies, . . . . .	.10

New subscribers can commence at any time. Payments for THE CIRCULAR, when sent by mail, should be made in a Post-Office Money Order, Bank Check or Draft, or an Express Money Order or Registered Letter. All postmasters are required to register letters whenever requested to do so.

Pay money only to authorized collectors having proper credentials. Returning your paper will not enable us to discontinue it, as we cannot find your name on our books unless your address is given.

In changing address always give the old as well as new one. Your name cannot be found on our books unless this is done.

We will continue to send papers until there is a specific order to stop, in connection with which all arrearages must be paid; but such an order can be given at any time, to take effect on the expiration of the subscription. All such orders will be promptly acknowledged by mail.

The Courts have decided that all subscribers to journals are responsible until arrearages are paid in full and an order to discontinue has been received by the publisher.

## Member of the American Trade Press Association.

Vol. XXIX. Nov. 28, 1894. No. 18.

THIS is our Holiday Number. We consider it as near approach to an art and literary magazine as the arbitrary limits of industrial journalism permit.

THE sixth assessment of the Jewelers' League for the year 1894, will close on Dec. 12th. Members should bear in mind that assessments will be made the first of each month beginning Jan. 1, 1895. This change will make the assessments regular and small in amount, a desideratum indeed.

ONE need only to have been present at the opening of the Italian opera season at the Metropolitan Opera House, New York, to have been thoroughly convinced that the profuse wearing of expensive jewelry is *au fait* in even the most exclusive social circles. The display of rich gowns and jewels was most elaborate.

ALVAN G. CLARK said, in response to an inquiry as to whether he should some time try to produce a telescope glass

still larger and more effective than the one regarding which he addressed the New England Association of Opticians last week, as fully reported in this issue of THE CIRCULAR: "When I started on this latest one I thought I should never attempt another of greater size, but I have come to the conclusion that, under certain conditions, I would." It would seem that one's ambition would be satisfied with producing a glass which brings to sight over 100,000,000 stars, but evidently the American spirit of competitive effort is insatiable.

FOR the past two or three years there have been numerous complaints made to the police authorities by manufacturing jewelers in Providence of the mysterious disappearance of considerable amounts of gold scraps and filings. A few culprits have been apprehended, but the police have been at a loss to discover what disposition was made of the stolen property. The discovery that John Nelson had been buying gold from two thieves may lead to a rapid solution of the problem.

### Watch Manufacturing in Japan.

WE have on two occasions referred in these columns to the prospective establishment of an extensive watch factory in the land of the Mikado. Later advices in this connection point to Phil. Wheeler as being the prime spirit in this movement. This gentleman will be remembered as the erstwhile watch factory and real estate boomer who managed the Otay watch manufacturing enterprise which died a painful death a couple of years ago. It was supposed that henceforth he would be found among the "innocuous desuetudes," but fate has been kinder to him than to his victims. In a communication from a member of the defunct Otay shop, now in San Francisco, it is stated that a number of American and foreign capitalists have formed a company to move the Otay plant to Japan, where one of the largest watch factories in the world will be built and run by American workmen. Japan has no watch factory, and Wheeler, who is to be superintendent of the new concern, says there is no reason why an enormous business could not be done there if properly managed. A scheme to establish a watch manufacturing plant in Japan may be feasible, but with Phil. Wheeler as its propounder, we are inclined to infer there is a nigger in the woodpile somewhere or t'other.

### Foreign Restrictions of Trade.

THE new tariff bill which has been submitted by the Spanish Minister of Finance to the Cortes numbers among its salient features some provisions dealing with the trade of the United States with Cuba and Porto Rico. This trade has been seriously affected by the provisions of the

new tariff law of the United States abolishing reciprocity. The advices at hand do not indicate just what the provisions of the proposed Spanish tariff are. We only know that the minister in submitting the new bill expressed the hope that the proposed tariff revision would not interfere with the treaties of commerce already ratified, and that the import duties would not be reduced below the scale of the treaties not yet voted by the Cortes. In addition, it is proposed that the government be authorized to extend revised import duties to nations willing to grant reciprocity. According to the cabled summary, Portugal and the Spanish-American republics alone will enjoy special treatment which will not be extended to other nations. The latest movements abroad, taken as a whole, seem to point to an extension of restrictions upon trade.

### Prize Competition for the Timing of Pocket Chronometers.

The Industrial and Commercial Department of the Society of Arts, of Geneva, Switzerland, has resolved to organize a second international competition for the timing of pocket chronometers.

Since the first competition of that kind, held in Geneva in 1876, the art of timing pocket chronometers has much improved. Official chronometric services are now to be found in the observatories of many countries, and in some places special prizes are awarded for the best results. Therefore an international competition will be highly interesting, provided the makers of highest class watches avail themselves of that opportunity of testing their abilities. In order to give them the best chances of success the rules of competition have been framed eighteen months in advance.

The trial will last from May 15 to June 29, 1896, at the Geneva Observatory. Each competitor must send a minimum of three chronometers, but may send a maximum of fifteen. He may obtain only one reward, rated on the mean performance of his three best chronometers. The sum of \$1,000 will be awarded in prizes. Each chronometer having performed satisfactorily will be entitled to a special certificate. Further particulars will be sent free on application to M. Dupuis, Athénée, Geneva, Switzerland.

### The Thistle Watch Case Co. Decide to Disband.

NEWARK, N. J., Nov. 21.—The Thistle Watch Case Co., after having expended some \$5,000 in litigation of certain patents owned by the company, on which they depended to build up a large business, have decided to dissolve their organization.

The company have never manufactured watch cases, the backers deciding to establish their legal status first. The present action affects but few people, as the chief stockholders are R. J. Quigley and W. K. McNaught, of Toronto, Canada, and Alexander Milne, of this city.

### New York Notes.

The Gorham Mfg. Co. have entered a judgment for \$96.68 against Marie R. Legendre.

Elias Pitzele has satisfied the judgment for \$394.50 entered Sept. 19th. last by E. L. Anrich.

Joseph Rundbach, 2168 Third Ave., has given a chattel mortgage to Amelia Rundbach for \$1,000.

The judgment for \$476.27 entered by E. M. Gattle, Sept. 8, 1894, against Adolph L. Roeder has been satisfied.

Among the passengers sailing for Europe on *La Touraine*, which left Saturday, were Chas. L. Dwenger and J. R. Paillard.

H. H. Lambert, of Aikin, Lambert & Co., 19 Maiden Lane, has started on his last trip for the year through the Eastern States.

P. E. Robinson, for many years a traveler for Aikin, Lambert & Co., is again in their office, 19 Maiden Lane, and will be pleased to have his old friends call on him.

N. H. White, of N. H. White & Co., was one of the five citizens and tax-payers of this city who preferred the charges to the Court of Common Pleas on which Police Justice Patrick J. Divver is to be tried.

The annual dinner of the New York Jewelers' Board of Trade, said E. V. Clergue, chairman of the committee having the matter in charge, will be held at the Hotel Waldorf, 32d St. and Fifth Ave., Tuesday evening, Jan. 29th, 1895.

Tiffany & Co. have satisfied the judgment for \$1,415.27 mentioned in THE CIRCULAR last week, which was obtained in the Supreme Court Nov. 16th by Myrtella F. Hart, in a suit to recover the value of a trunk full of articles stored by her with Tiffany & Co., and delivered to her husband by the firm.

The Jewelers' Security Alliance have notified the trade that two gangs of burglars are operating in the vicinity of New York. One gang has been working in towns in the southern part of the State, Long Island and western Connecticut, while the other has operated in Belvidere, Elizabeth and other towns in New Jersey.

A new firm, Benedict & Warner, importers of precious stones, was formed recently. The partners are H. R. Benedict and J. L. Warner, and the firm will continue at 21 Maiden Lane, the business formerly conducted at that address by Mr. Benedict.

Judge Cowing, in General Sessions Wednesday suspended sentence on Adolf Roller, a young man who a few days ago pleaded guilty to an indictment for grand larceny preferred against him by Marcus & Co., jewelers, at 857 Broadway, from whom he had obtained on memorandum a pair of diamond ear-rings valued at \$200 which he never returned.

The suit of Bechtold against Clairmont came up for trial before Judge Beach in the Supreme Court, Special Term, Tuesday

The action which is for a dissolution of the partnership of Adolph Bechtold and Joseph J. Clairmont known by the firm name of Clairmont & Co., opticians, 535 Fifth Ave., and 143 E. 23d St., was brought about a year ago by Mr. Bechtold, who also asks for an accounting. On Dec. 5th last J. H. Spellman was appointed receiver for the firm and from him Mr. Bechtold later purchased the assets of the concern. The partnership was formed over two years ago.

James T. Clark, a diamond broker, who makes his headquarters with Alfred H. Smith & Co, 182 Broadway, Friday caused the arrest of William M. Post, whom he charged with larceny. Post, according to the complaint, has possession of a diamond weighing  $1\frac{3}{4}$  carats and valued at \$185, which he obtained on the pretense of having a purchaser for it. Clark left it with him, he says, with the understanding that he should return it or its value within a reasonable time. Clark claims to have waited a week, and demanding a settlement of Post, was put off from time to time.

#### The Establishment of D. Gruen & Son.

D. Gruen & Son, manufacturers of all kinds of complicated watches, recently started in business in Columbus, O. The partners, D. and F. G. Gruen, are both thoroughly conversant with all the details of the watch business, particularly the practical side. D. Gruen is well known to the trade by reason of his connection with Gruen & Savage, in which he was the senior partner, and also as having been president of the Columbus Watch Co. for several years.

His son, F. G. Gruen, returned from Europe Saturday on the *Saale*, having spent six months in Glashütte, Germany, in the interests of his firm, perfecting a new watch which they have now introduced in 18 size. A 16 size will soon follow. D. Gruen & Son, have their offices at 935 Denison Ave., Columbus, O., and their factory in Glashütte, Germany.

#### Strike of the Diamond Cutters of New York.

America's infant industry, diamond cutting, is now affected by the same trouble that has paralyzed its parent in Amsterdam, a strike. Monday was the time that it commenced to take effect and at the time of THE CIRCULAR'S going to press the strike had not, it seemed, reached its full proportions.

From what a CIRCULAR reporter learned it appears that in some establishments there has been a disagreement between employers and employes over the amount paid per mill to setters. This has been generally \$2.50, but a demand for \$3.00 and even \$3.50 has been made, and, as the setters are paid by the polishers, the demand necessitates that the latter in turn be paid more. The strike commenced at the factory of Wallach & Schiele, 128 Mott St., New York, about 35 of the 40 men employed

going out. The men of Arnstein Bros. & Co.'s factory at 45 John St., followed and the strike quickly became general. Men from Wallach & Schiele's went to the factory of Stern Bros. & Co., 29 Gold St., and soon induced about 80 of the polishers and setters there employed to join them. The number was also increased by the 25 hands employed in the factory of Herman Levy, 15 Dutch St., and six of the 15 employes of D. De Sola Mendez & Co., 61 Maiden Lane.

A meeting of the strikers was later held at their headquarters in Bleecker St., where preparations, it is said, were made for the formation of a union, and a scale of prices agreed to. A CIRCULAR reporter was told that representatives from the employes of Zilver Bros.' factory, in Brooklyn and the Sanders & Bruhl works, Newark, N. J., attended this meeting. This however, could not be verified. Mr. Lilienthal, manager of the latter concern, refused to be interviewed about the strike.

When a CIRCULAR reporter called at Stern's factory he found the upper floors deserted, but the lower floor which is run for the firm by Solomon and J. H. Hudemacher was working full blast, none of these workmen having, up to that time, joined the strikers. Leopold Stern characterized the strike as the work of foreign socialistic agitators. His men, he said, were getting good wages and steady work and must have been intoxicated by their own prosperity when they thought of joining in the movement. The men were steadily employed for the last 12 months and were thoroughly satisfied. The setters had recently demanded \$3.00 per mill instead of \$2.75, but an amicable arrangement had been made Saturday last to which all the employes agreed. He had received no further demands and had no intimation of the strike. During a temporary stop of the machinery, the strikers happened to come in and soon induced about 75 of their men to join the movement.

At the Arnstein factory H. M. Heyderman, the superintendent, stated that the employes must have struck through "sympathy" as his firm was paying the setters the amount they demanded from other factories, namely, \$3.00 per mill.

At the office of Wallach & Schiele it was stated also that no grievance existed among the men, or was any known. They knew nothing further than the fact that their men had "just walked out" Monday noon.

D. De Sola Mendez said his men must have struck through sympathy, as he had adjusted with them the scale for the setters.

None of the employers whom the reporter saw had, up to 11 o'clock Tuesday morning, received any word or delegation from the strikers, though it was generally expected that a committee from the men would wait upon the various firms sometime during the day.



**L. TANNENBAUM & Co.,**  
IMPORTERS AND CUTTERS OF

**Diamonds and Precious Stones,**

Cor. Maiden Lane & Nassau St.,

**NEW YORK.**

25 Hatton Garden, London.

TELEPHONE, LONG DISTANCE, 1959 CORTLAND .

## Special Announcement.

Mr. L. Tannenbaum begs to notify his customers and the trade in general, that he has largely extended his facilities for cutting and polishing. Hereafter he will cut and polish not only RUBIES and SAPPHIRES, which has been done for the past 15 years with increasing and gratifying success, but

# DIAMONDS

and all other stones which undergo this process.

Modern machinery of the best and most approved pattern, and workmen of the highest class will enable Mr. Tannenbaum to offer, direct from the cutter's hands, that excellent workmanship demanded by American buyers, at

## PRICES THAT DEFY COMPETITION.

Nor will buyers of Diamonds be the only people benefited. Mr. Tannenbaum imported a five years' supply of rough Rubies and Sapphires DUTY FREE under the old tariff. These goods are now being cut and polished and it is very evident that in these particular stones he can make UNAPPROACHABLE PRICES.

New York as the future Diamond Market is not a phantasy. American cutters will be shown an assortment of rough, at prices which will perhaps cause them to believe that this has already been brought about. All arrangements have been made by the firm for enormous shipments of DIAMONDS, EMERALDS, PEARLS, SPINELS, CATSEYES, MELLÉS and all kinds of Precious Stones, although to-day the assortment offered by L. Tannenbaum & Co. ranks second to none in this country.

HIGHEST PRICE PAID for all AMERICAN PEARLS and OTHER PRECIOUS STONES.

### Alvan G. Clark Talks on Telescopy to Opticians.

BOSTON, Mass., Nov. 24.— The possibility that he will some day try to produce a telescope more powerful than the great glass now in hand was admitted by Alvan G. Clark last Monday evening in his talk to the New England Association of Opticians. This may or may not be an indication that he has been consulted by any of the big observatories on the subject. The Chicago glass is likely to provoke some rivalries in the future, however, and it would surprise no one, presumably not even Mr. Clark himself, if an order for a larger lens should be received by him.

"I thought at first that I would have something to say about the eye as an optical instrument," said Mr. Clark when he began his address, "but probably many of you know as much as I do about that subject, and a physician could talk on it better than I can, so I have come to the conclusion that nothing I can speak about would interest you more than what might be called a history of the great glasses we have made."

He proceeded to outline the processes through which the modern telescope passes,

describing the difficulties incident to the production of objectives that will give absolutely round images of stars. In the making of large glasses it was his practice in all cases, he said, to produce a small glass first and copy that on an enlarged scale. Every glass made by him was in a certain sense an experiment. A distinguished German mathematician and astronomer had once importuned him to divulge the formula by which he computed the curves for the glass manufactured for a certain observatory. He had replied that there was no formula. The scientist, however, said there wasn't a mathematician in the world who could arrive at a result so nearly perfect by his calculations.

The big glass that he has been at work upon for the University of Chicago, Mr. Clark said, is nearly finished. It was taken out a few weeks ago and through it some very fine views of Mars were obtained. The focus is about 63 feet, and varies very slightly from what the maker intended at the outset.

To get all the light which strikes on an area having 40 inches diameter, which is the size of this glass, refracted down 63 feet, from a point of light at what is known

as infinite distance, so as to come to a point, and nothing but a point, seemed difficult the speaker said. It was difficult, too, but the work was done so exactly that a human hair placed at the focus would cover up a number of stars.

In the making of great glasses a number of things had to be considered. Extreme care had to be used lest when one viewed a stellar object through the telescope it should appear angular, square, elliptical, or anything but round. For locating spherical aberration he used the mirror test. As the glass neared completion, any work upon it, such as rubbing down the surface for the purpose of correcting errors in its curvature, affected it to a certain degree by making its temperature uneven. Before the result of any such work was tested he allowed the glass to rest until the effect of the disturbances had been overcome by a return to the normal temperature. Sometimes two or three hours time would be adjudged necessary for the lens to resume its condition. Progress was necessarily slow. It might take a year and one-half to complete a large lens.

Jeweler Ordway, Lowell, Mass., is closing out his business.

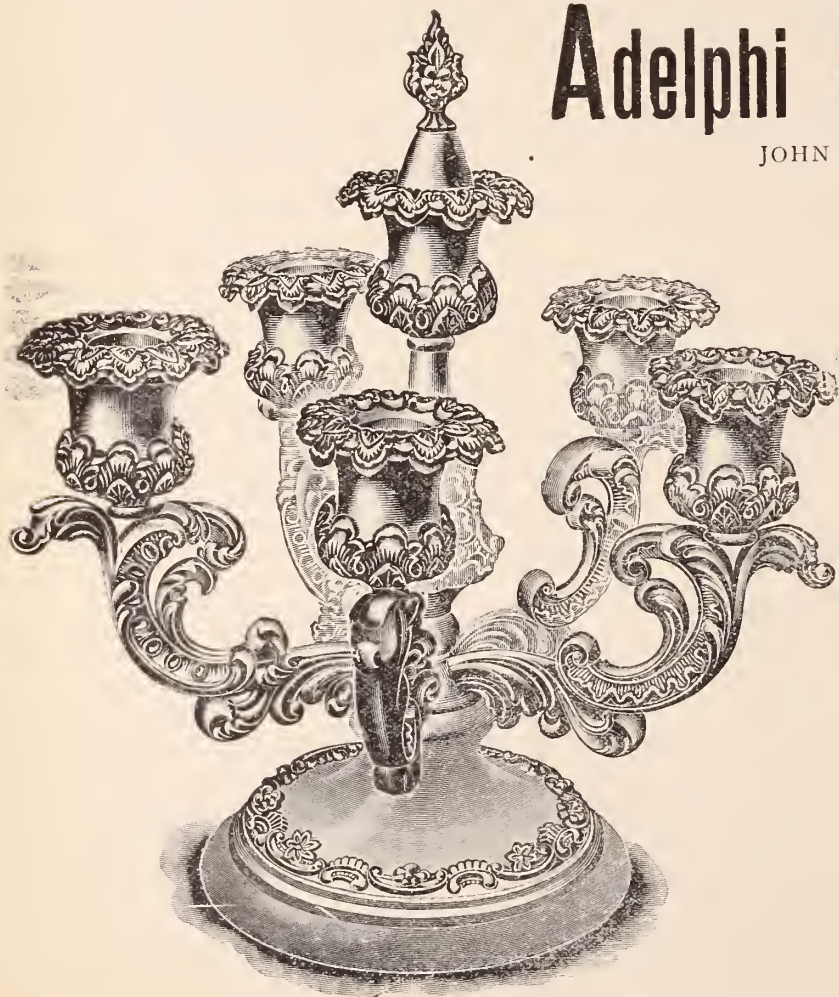

NO. 6—CANDELABRUM.

We have a full line of CANDELABRA IN FANCY ROCCOCO and other styles, also a full line of HOLLOW WARE and NOVELTIES, comprising the best sellers in the market.

# Adelphi Silver Plate Co.,

JOHN SCHIMPF & SONS, Proprietors.

Manufacturers of  
Finest Grades of

Electro  
— Silver  
AND . . . . .  
Gold  
Plated Ware.

All goods are of our own design.

OFFICE,  
62 John Street, New York.

FACTORY,  
Brooklyn, N. Y.

BRANCH OFFICE,  
34 Monroe St., Chicago, Ill.

THE LARGEST AND FINEST LINE OF  
FERN DISHES, BREAD TRAYS, ETC.,  
EVER SHOWN.

# STERN BROS. & CO.,

Cor. John and Nassau Streets, = = = NEW YORK.

CUTTING WORKS: 29 & 31 Gold St.

LONDON OFFICE: 29 Ely Place.

## Our Diamond Cutting Works

were established two years ago, and this was the first attempt to cut diamonds on an extensive scale in the United States.

## Our Factory

is to-day the largest and most complete of its kind in this country and rivals the best equipped establishments in Europe.

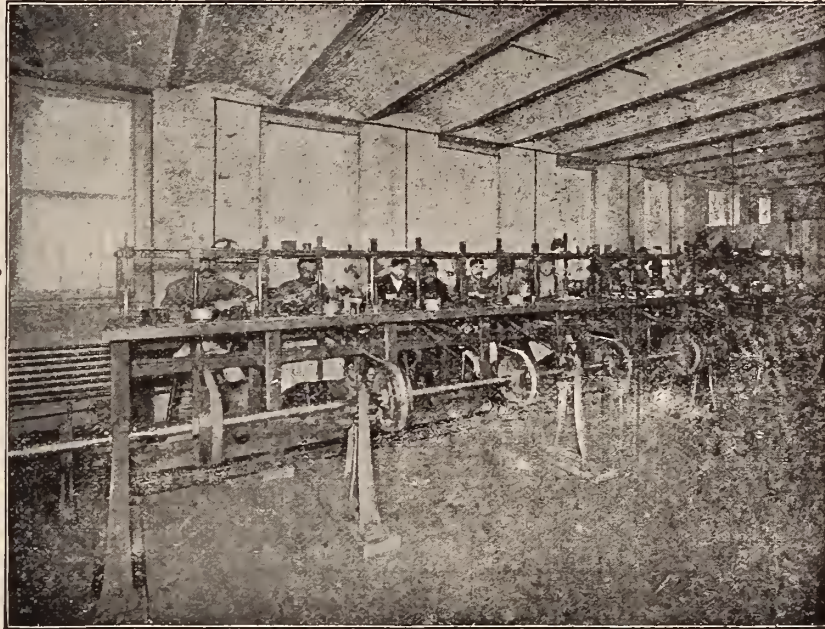

PART OF EAST WING ON THE MIDDLE FLOOR.

## Our Workmen Are All Skilled Artisans,

having had years of experience in their respective departments.

For finish and cut our goods bear the closest scrutiny of the most critical buyer.

## These Statements are Absolute Facts

and not used for the mere purpose of advertisement.

# Birth-Month Jewelry.

.....THE NEWEST AND MOST EXCLUSIVE NOVELTY. MADE ONLY IN 14 KT.

THE NOVELTY IN JEWELRY FOR THIS SEASON IS WHAT IS FITTINGLY CALLED

!!!!!! BIRTH-MONTH JEWELRY. !!!!!

IT IS MADE AFTER DESIGNS COMBINING THE ZODIACAL SIGN AND THE FLOWER EMBLEMATIC OF EACH RESPECTIVE MONTH AND THUS TELLS THE STORY OF THE MONTH OF BIRTH AND MAKES A VERY INTERESTING BIRTHDAY SOUVENIR, AND ALSO AN APPROPRIATE GIFT INDEPENDENT OF ANY SUCH ASSOCIATION.

THIS JEWELRY WILL BE MADE IN THE FORM OF BROOCHES, SLEEVE-LINKS AND SCARF PINS.

IN ORDER THAT THEY MAY NOT BECOME TOO GENERAL OR COMMON THE MANUFACTURER HAS DECIDED TO LIMIT THE PRODUCTION OF THE ARTICLES TO 300 OF EACH LINE.

DURAND & Co.,

MAKERS OF JEWELRY AND IMPORTERS OF PRECIOUS STONES.

FACTORY, NEWARK, N. J.

44 EAST 14TH STREET, NEW YORK.

# The "TRAJAN" Pattern.

DESIGN PATENTED.



Table Spoon.  
Average Weight to the Dozen,  
28 oz.

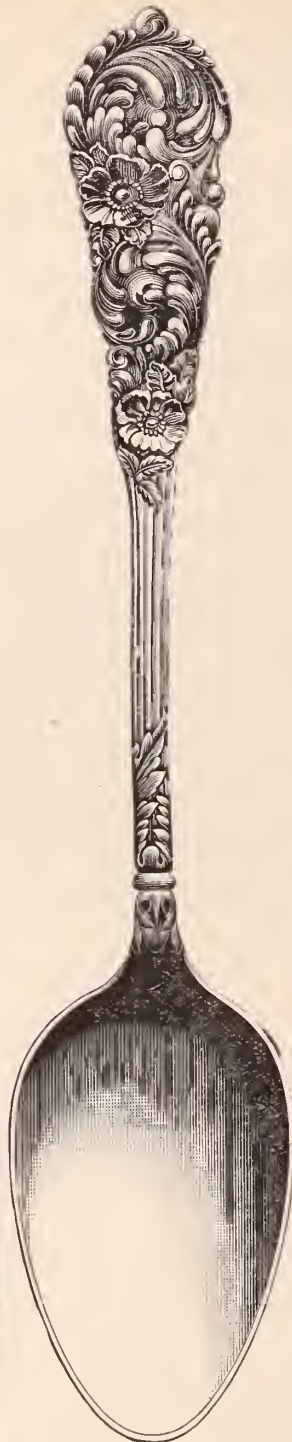

Dessert Spoon.  
Average Weight to the Dozen,  
20 oz.



Tea Spoon.  
Average Weight to the  
Dozen,  
12 oz.



Trade Mark  
Sterling  
 $\frac{925}{1000}$  FINE.



Dessert Fork.  
Average Weight to  
the Dozen,  
20 oz.



Table Fork.  
Average Weight to the Dozen,  
28 oz.

The TRAJAN Pattern is universally accepted as the richest in design and execution of any highly ornamented pattern ever offered to the trade.

It is furnished regularly in weights as specified above, and in heavier weights to order. The fancy pieces, numbering over one hundred, are artistic in design, and include all the latest ideas in Table Service.

REED & BARTON, Silversmiths, TAUNTON, MASS.

NEW YORK OFFICE,

37 UNION SQUARE.

CHICAGO,  
34 WASHINGTON STREET.

PHILADELPHIA,  
925 CHESTNUT STREET.

Our Goods are Widely Advertised in the Maga

# REED & BARTON, Silversmiths,

37 UNION SQUARE, NEW YORK CITY.  
OFFICES AND FACTORIES, TAUNTON, MASS.

Trade Mark



CHICAGO OFFICE,  
34 WASHINGTON STREET.

PHILADELPHIA OFFICE,  
925 CHESTNUT STREET.

Sterling

925  
1000 FINE.

## “LA REINE”

Design Patented.



Table Fork.

Average Weight to the Dozen,  
28 oz.



Dessert Fork.

Average Weight to the Dozen,  
20 oz.



Tea Spoon.

Average Weight to the Dozen,  
12 oz.



Dessert Spoon.

Average Weight to the Dozen,  
20 oz.



Table Spoon.

Average Weight to the Dozen,  
28 oz.

The “LA REINE” is one of the most popular patterns ever furnished to the trade.

The design is brought out in high relief, and for beauty and excellence of workmanship it stands unrivaled.

It is furnished in weights as mentioned under each article, and in heavier weights to order.

A complete variety of fancy pieces is made in this pattern, numbering over one hundred, and embracing the latest ideas in Silver Service, worked into the most pleasing and practical forms.

zines, a Feature which Dealers will appreciate.

### Their Plan for Stealing Scraps Brought Them to Grief.

PROVIDENCE, R. I., Nov. 24.—Felix McLaughlin and William I. Wallace were arrested last evening by Detectives Swan, Merrill and Parker, in the retail jewelry establishment of John Nelson, while in the act of selling stolen gold scraps amounting to about 30 pennyweights.

McLaughlin, who is about 20 years of age, has, since Sept. 19, worked for the Waite, Thresher Co. The police authorities say that almost the first day he worked there he began stealing gold scraps and filings, and for a long time his thefts have amounted to from 25 to 50 pennyweights of gold each day. During the noon hour when the workmen had abandoned their benches for the midday meal, McLaughlin would move about from bench to bench, and while seemingly carelessly lounging over the trays containing the filings and scraps produced by the morning's work, would abstract a small quantity of the gold. This in the end amounted to considerable each day. Every evening, after the shop had closed, he was in the habit of meeting a friend, William Wallace, who is a jeweler in the employ of the Kent & Stanley Co. He is about the same age as McLaughlin.

Wallace received from his friend the gold that he had stolen during the day and took it to the jewelry establishment of John Nelson. Thence, the police say, Nelson took the gold to a room in the rear of his shop fitted up as an office, and weighed and paid for it. The police claim that the price paid was much under the market value; in one instance, in return for 50 pennyweights of gold, Nelson paid Wallace only \$5, which

is only 10 cents a pennyweight. Having disposed of his booty, Wallace would rejoin his companion, and the men divided the proceeds.

The Waite, Thresher Co. became satisfied some time ago that they were being systematically robbed of gold stock and the police have been investigating the case. They soon became satisfied that McLaughlin was the thief, and Wallace was shortly discovered as his accomplice. It was thought that the two men had other accomplices and accordingly no arrests were made immediately in hopes that the whole gang might be apprehended. Becoming satisfied that the two were operating as one, it was decided to arrest them. It is estimated that the thefts would amount to about \$2,500 or more, as McLaughlin has been stealing on an average between 25 and 50 pennyweights a day, four days in a week, since he began to work for the Waite, Thresher Co.

Mr. Nelson asserts his innocence of any criminal relations with the young men, and claims to have done but a comparatively small business with them. It is a part of his regular business to buy and dispose of old gold. He claims to do a business of upwards of \$20,000 every year and buying old gold is the principal part of it.

At a late hour this afternoon Mr. Nelson was arrested, charged with feloniously receiving from William Wallace gold clippings. He pleaded not guilty, and was held in the sum of \$500. Mr. Nelson is an expert in handling gold. He served four years as an assayer at the refinery of John Austin, and it is claimed by the authorities that he has been doing a very extensive business in purchasing stolen scrap gold for several months.

### Premier Rhodes, of Cape Colony, Hints at Revenge for the Diamond Duty.

LONDON, Nov. 17.—Regarding the diamond trade, Premier Cecil Rhodes, of Cape Colony, said to-day in an interview:

"We went to Chicago and spent \$10,000 at the World's Fair. The only thing America did in return was to impose a prohibitive duty. America has usually taken about one-third of the export of Cape diamonds, but during the last two years of the depression in the United States, the sale has been much reduced. The output of diamonds is regulated. We could mine three times the quantity of diamonds produced, but we could not use them and there is no advantage in producing beyond a certain amount.

"I am a free trader; but if any country persistently shuts out the products of another country, I believe the country discriminated against is perfectly justified in shutting out the products of the country which first imposes the discriminating duties."

### Jeweler Dilger's Brave Fight With Two Bad Men.

CHICAGO, Ill., Nov. 26.—Robert Good and Edward Moore were arraigned before Justice Severson at the West Chicago Ave. Police Court, Nov. 19, to answer to charges of robbery, burglary and assault with deadly weapons, and are each held to the Criminal Court in bonds aggregating \$5,000, and were also fined \$50 and costs for carrying concealed weapons.

Last Saturday afternoon George Dilger, jeweler, 419 W. Chicago Ave., had a desperate fight with the two men, who had entered his store for the purpose of robbing him. When they approached him they commanded him to throw up his hands and submit to being robbed. Instead of obeying their command, however, he stooped down behind the counter and took his revolver from the cash drawer. He rushed upon the two men, and pressing the revolver to Moore's head pulled the trigger, but the hammer struck an empty shell. Dilger then seized hold of the barrel of the weapon and struck Moore a powerful blow on the head, which laid the scalp open.

Seeing that it was useless trying to rob Dilger, the two men ran from the store with Dilger in hot pursuit. His cries for help attracted the attention of a number of men and also officers Ryan and Maschon of the West Chicago Avenue Station, who after a short chase succeeded in putting them under arrest. When taken to the station and searched, a revolver was found in Moore's possession and a large billy on Good. Each had a coat pocket filled with ground red pepper.

Fred. G. W. Weihe, Ocala, Fla., the pioneer jeweler of the place, Nov. 23 made a bill of sale of his entire stock of jewelry to Hennegen, Bates & Co., Baltimore, Md. Consideration unknown.

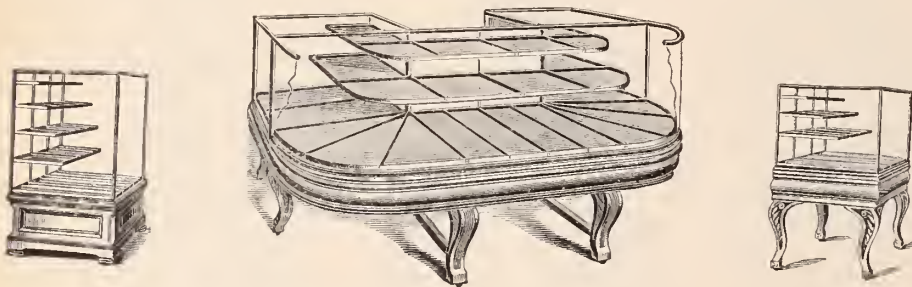

**WHEN** in the rush of the *Holiday Trade* you find there is not half room enough to display *Stock* and your *Store* is in disorder,  
**THINK**  
 of the advantages of the various forms of the Fletcher Patent Systems, and after Jan. 1st,  
**ACT**

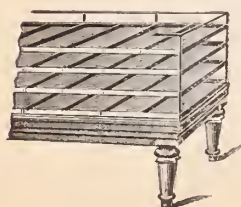

**FLETCHER MFG. CO.,**

259 WEST 27th ST., NEW YORK.

New Creations this Season. Send for Catalogue.

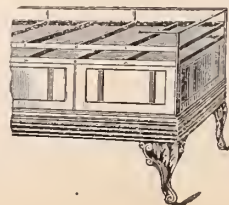

**News Gleanings.**

John Babbage, Antwerp, O., has sold out.

V. G. Kittle has a new jewelry store in Ute, Ia.

Mr. Kizer, of Rockford, Ill., has opened a jewelry store in Pecatonica, Ill.

Ingalls, of North East, N. Y., opens a branch jewelry store in Ripley, N. Y.

In a destructive fire in Sheffield, Ia., recently, the store of E. L. Boucher, jeweler, was burned out.

A. J. Rice, Columbus, O., has opened up a jewelry store next door to the post-office in Magnetic Springs, O.

L. D. Merrill, jeweler, Sparta, Wis., has purchased the stock of P. Scholler, Tomah, Wis., and will continue the business.

In a fire a few days ago, in Belton, Tex., the jewelry store of U. F. Hiatt was burned out; loss \$5,000; insurance \$1,000.

The store of John Steitz, jeweler, Kinderhook, N. Y., was entered by burglars last Sunday and jewelry valued at about \$300, was stolen.

Wm. Franz's jewelry store in Pottsville, Pa., was entered by burglars last week through a rear window. Goods valued at \$500 were stolen.

William S. Manning, Saugerties, N. Y., who has been confined to his home by illness, has so far recovered as to be able to attend to business again.

In a destructive fire Nov. 18th in Houston, Tex., the business of L. Lechinger, jeweler, was damaged to the extent of \$2,000: insurance, \$4,500.

Bell Bros. Co., Ogdensburgh, N. Y., commenced an auction sale, Nov. 26, to close out their present stock of bric-à-brac, china, cut glass, etc., and to reduce their other lines.

The stock of W. H. Gilmore, Utica, N. Y., was bid in 40 cents on the dollar, by W. K. Gilmore, and the fixtures at 25 cents. The inventory showed a valuation of \$10,300 and fixtures \$500.

H. A. Potter, who has been in the jewelry business in Pittsfield, Mass., for 10 years, has just returned from a trip to San Diego, Cal. While there he purchased a place, and intends going there Jan. 1 and making it his home.

A prominent social event in Pottsville, Pa., last week was the wedding of Miss Ray Rubinsky, daughter of I. Hyman Rosenthal, wholesale dry goods dealer, and I. Hyman Rosenthal, son of Harris Rosenthal, dealer in jewelry, New York.

A noticeable improvement on Montgomery St., Jersey City, N. J., is a large clock in front of C. G. RoCHAT's jewelry store at No. 73. It is a big clock which stands on a post 20 feet high. The clock was made by the E. Howard Watch & Clock Co.

Dr. W. C. Gilliam, Spartansburg, S. C.,

an oculist of some note, jumped, early on the morning of Nov. 13th, from a third story window of the Ocala House, Ocala, Fla. in his sleep. He never regained consciousness, and died at 10.15 on the morning of the 14th.

**Philadelphia.**

Jos. D. Hughes, of L. A. Scherr & Co., has started on a business trip south.

Adolphus Sickles, of M. Sickles & Sons, returned last week from a Pennsylvania trip and started immediately after on a tour of New Jersey.

In Common Pleas Court on Friday Wm. McFarland obtained a verdict of \$102 from Lewis J. Fabian. The plaintiff purchased a watch on the guarantee that it was 18 karat gold. It wasn't.

John H. Williams was convicted in quarter sessions, last week, of entering the store of R. H. Saunders, S. 13th St., and stealing gold spectacles and other articles valued at \$35. He was sentenced to one year in the Penitentiary.

Trade visitors during the past week who were on buying missions included: C. Rudolph, Wilmington, Del.; C. S. Hunsberger, Sonderton, Pa.; B. C. Foster, Bristol, Pa.; John Lowe, Mauch Chunk, Pa.; John Denver, Bryn Maur, Pa.; Louis Pfleger, Trenton, N. J.; Chas. Kohler, Norristown, Pa.; Frank H. Barnett, Slatington, Pa.

M. B. Alebach, Walnut St., above 13th, was the victim of an unfortunate and painful accident last week. He tripped at the street railway switch-off at 7th and Sansom Sts., his foot catching on a rail, and being a heavily built man he fell with terrible force on his face. His nose received the brunt of the blow, but medical attendance, he hopes, will restore his features to their formerly at ractive expression and appearance.

**Omaha.**

E. S. Burbank has removed from S. 16th St. to 214 S. 13th St.

Rising City has a jewelry suit. W. E. Burlingim sues the Omaha National Bank for a conversion of stock.

A suspicious character, by name Mike Boler, was found by officers Hayes and Kissane, with more jewelry stock about him than he could honestly account for.

The Van Cott Jewelry Co. have moved from their late quarters on 16th St. to the first floor, of the Barker block, corner of 15th and Farnam St., where they have a salesroom more than three times as large as the place they leave.

Pat Crow, who has just been arrested in Milwaukee for stealing \$600 worth of diamonds from a Denver jewelry store, used to flourish in Omaha. He was once arrested here for arson. He was a bad black-bird, was this Crow, and soon brought up in the penitentiary at Joliet, Ill., for the boldest kind of a daylight robbery in Chicago, in which he shot three persons, one a policeman, and escaped for a time.



**THE BATHER.**

23 Inches High.

**THE FINEST AND MOST STRIKING PRODUCTION SEEN THIS**

**SEASON.**

PRICE **\$17.00** NET CASH.

**LEVY, DREYFUS & CO.,**  
9 & 11 Maiden Lane,  
New York.

Dealers who contemplate buying Fancy Porcelain Goods may leave the selection to us. \$50 or \$100 will make a fair beginning. Strangers to us should send check with order. Correspondence freely answered.

## Our Traveling Representatives

Traveling representatives may consider these columns open for the publication of any news or items of interest regarding themselves or their confreres.

**R**ICHARD Everett, formerly with the Dennison Mfg. Co., now travels for Clarence W. Sedgwick, 11 E. 20th St., New York.

Louis Berger, formerly with L. H. Keller & Co. and Henry Zimmern &

Co., New York, is now hustling through New York State and New Jersey in the interest of H. B. Peters, 177-179 Broadway, New York.

Among the travelers in Kansas City, Mo., last week were: Herbert Somborn, Albert Berger & Co.; Maj. Brooks, Brooks & Pike; E. Block, W. & S. Blackinton.

Among the many traveling salesmen who last week passed through Detroit were: C. L. Ferre, O. W. Bullock & Co.; Mr. Crowley, with A. Schwob; R. L. Moorhead, R. L. Moorhead & Co.; Mark Franklin, D. L. Roe & Co.; Gus W. Strandberg, E. L. Spencer & Co.; Mr. Harris, Ansonia Clock Co.; V. Jacobi, Providence Stock Co.; Mr. Barlow, J. T. Inman & Co.; Mr. O'Connor, Essex Watch Case Co.; W. W. Middlebrook, B. A. Ballou & Co.; Mr. Gregory, Strobell & Crane; W. C. Coombs, M. B. Bryant & Co.; John W. Case, H. F. Carpenter; Frank Alden, H. W. Wheeler & Co.; Stephen B. Kent, William H. Ball & Co.; J. H. Granbery, Reeves & Sillocks; S. W. Abbey, E. Ira Richards & Co.; I. S. Richter, Bruhl Bros. & Co.; and Alfred Varian, Dennison Mfg. Co.

The following representatives of wholesale houses were in Louisville, Ky., last week: Geo. W. Mindil, American Watch Case Co.; F. L. Davies, C. G. Alford & Co.; Morris Lissauer; Mr. Gratteman, Snow & Westcott; Mr. Crane, Strobell & Crane; Thos. H. B. Davis, Middletown Plate Co.; Jos. Beach, Wilcox Silver Plate Co.; Harry Osborne, Whiting Mfg. Co.;

Arthur Totten, Rogers & Bro; Robert Welch, Welch & Miller; A. H. Bogani, L. H. Keller & Co.; Thos. E. Rogers, Hayes Bros.; Mr. Van Pelt, for S. Lindernborn; Fred L. Baker, Hayden W. Wheeler & Co.; Wm. Smith, Newark Tortoise Shell Novelty Co.; Benj. Eichberg, Eichberg & Co.; Charles W. Hughes, Wood & Hughes; F. H. Carpenter, Alfred H. Smith & Co.; Mr. Cook, Bergstein & Son; Frank H. Dana, G. E. Luther & Co.; V. L. Burgesser, Kremenetz & Co.

Traveling men in the Hub last week included: W. S. Campbell, Day & Clark; William H. Jones, Larter, Elcox & Co.; Fred H. Carpenter, R. F. Simmons & Co.; Samuel L. Howland, Eisenmann Bros.; Chris Morgan, Rogers & Brother; G. B. Osborn, William Smith & Co.; A. C. Lord, Lord Bros. Mfg. Co.; Mr. Woodman, Woodman, Cook Co.; Col. John L. Shepherd, Keystone Watch Case Co.; Mr. Miller, Seth Thomas Clock Co.; Mr. Springfels, Springfels Mfg. Co.; T. B. Wilcox, Jr., Pairpoint Mfg. Co.; Pembroke S. Eddy; Chas. Bennett, Jacob Bennett & Son; A. Kaufman, Bruhl Bros. & Co.; E. A. Karelson for M. D. Rothschild; J. E. Karelson, E. Karelson & Co.; Leverett S. Lewis, Randel, Baremore & Billings; David S. Townsend, E. A. Neresheimer & Co.; D. F. Adams; Nat Barstow, Barstow & Williams.

Energetic hustlers noticed in Syracuse, N. Y., the past week were: Simon Goldsmith, Arthur J. Kahn & Co.; Frank F. Gibson, for William Kinscherf; W. W. Williams, Arnold & Steere; George W. Smith, Carter, Sloan & Co.; A. Rutherford, Kirby, Mowry & Co.; Wm. G. Lenhart, Cross & Beguelin; A. T. Sansbury, Hayes Bros.; Mr. Sylvia, Mt. Washington Glass Co.; James F. Barclay, R. Wallace & Sons Mfg. Co.; Mr. Waterman, Waterman & Lehmann; C. A. Vanderbilt, Coddling Bros. & Heilborn; Henry B. Hall, The Biggins-Rodgers Co.; John W. Sherwood; Mr. Snedeker, E. Aug. Neresheimer & Co.; Mr. Koehn, for Alfred Koehn; C. E. Barber, Gorham Mfg. Co.; A. L. Halstead, The Barbour Silver Co.; H. D. Mix, Wightman & Hough Co.; M. Baum, Rothschild Bros.; S. Glenn Walmsley, Tenner & Baum; O. S. Clark, C. G. Alford & Co.; Mr. Davidson, Harrison Bros. & Howson; Geo. B. Caldwell, Plainville Stock Co.; E. L. Mum-

ford, Waite, Thresher Co.; M. L. Jacoby, Providence Stock Co.; G. W. Strandberg, E. L. Spencer & Co.; L. Combremont.

James R. Brown, traveler for G. B. Barrett & Co., has been ill during the past week, but bravely started out on Monday.

"C. T.'s" in Pittsburgh, Pa., during the week of Nov. 19, were: R. A. Thompson, for Henry Glorieux; Mr. Crane, Strobell & Crane; S. M. Levy, Adolph Schwob; James A. Cheney, Ludwig Nissen & Co.; George S. Pollitz, Rice & Hochster; M. Baum, Rothschild Bros.; Mr. Ashton, Kent & Stanley Co.; Stephen Woods, Battin & Co.; Charles W. Hughes, Wood & Hughes; J. W. Block, for Charles Knapp; C. J. Suplee, Belknap, Johnson & Powell; Monroe Engelsman, for Maurice Weil; Geo. S. Melville, Acme Silver Plate Co.; C. A. Cuppia, Ludwig, Redlich & Co.; Thos. E. Rogers, Hayes Bros.; Fred J. Foster, Unger Bros.; C. A. Vanderbilt, Coddling Bros. & Heilborn; Wm. D. Elcox, Larter, Elcox & Co.; J. E. Alexander, for Frank W. Smith; J. E. Simonson, A. J. Hedges & Co.; O. C. Lane, Reed & Barton; F. M. Neefus, for William Link; H. A. Bliss, Kremenetz & Co.; S. P. Arnold, for Theodore Haviland; Mr. Bardel, Heller & Bardel; Geo. W. Blecker, Bassett Jewelry Co.; H. V. Lenuau, G. W. Cheever & Co.; W. R. Bristol, C. Rogers & Bros.; Wm. Copeland, Martin, Copeland & Co.; Simon Sichel, Eichberg & Co.; Ernest Block, W. & S. Blackinton; and John A. Abel, Lewis, Kaiser & Luthy.

Salesmen in Philadelphia the past week had among them: M. Lawton, S. B. Champlin & Sons; Harry Dougherty, E. Howard Watch & Clock Co.; H. D. Miller, Pairpoint Mfg. Co.; J. H. Cheney, Ludwig Nissen & Co.; B. Osborn, Jr., J. A. Riley & Sloan Co.

## O. NEWMAN,

Successor to L. NEWMAN,

GOLD and... **PLATER,**

...SILVER **PLATER,**

75 & 77 Nassau St., N. Y.

Owing to the death of my father, I beg leave to notify our customers and the trade that the business will be continued by me at the old stand with new improvements, which will produce better results than heretofore.

—Etruscan Coloring a Specialty.—

### I Will Instruct You

How to tell genuine PEARLS from imitations for 25 cents.

**I. BROADBENT,**

No. 4 So. 42d St., Philadelphia.

A. A. MARGOT.

**MARGOT BROTHERS,**

E. F. MARGOT.

Watch Case Manufacturers, Engine Turners and Jobbers.

11 FRANKLIN ST. (FORMERLY 23 WATER ST.) BOSTON, MASS.

Special Attention to Watch Case Repairing, Springing, Re-engine Turning, Engraving, Polishing, etc. Flat Glasses Fitted. Jewelry, Silverware, Dies, etc., engine turned.

Particular Attention to Orders by Express.

# THE ARTHUR CO.,

## DIAMOND MACHINERY

LEADING DESIGNERS  
AND BUILDERS OF

IN THE UNITED STATES.

Machine Works, 86 John Street and 188-190 Front Street, NEW YORK.



**Fox Bros. & Co.'s Plan for a Diamond Cutting Works.**

Sol Fox, of Fox Bros. & Co., Cincinnati, O., has been in New York, the past fortnight, making arrangements for the establishment of a diamond cutting shop in the Queen City. The Arthur Co., 86 John St., New York, will set up the plant which will contain all the improvements in diamond cutting and polishing machinery and appliances to date. This company have *carte blanche* in the matter.

The works will give employment to about 50 operatives, superintending whom will be a general manager with a foreman over each department. Sol. Fox will have an office in connection with the works, and will manage this branch of Fox Bros. & Co.'s business. He will sail for Europe early in December to arrange with one of the most prominent diamond cutters of Amsterdam to serve as the firm's European representative, and as soon as these preliminaries are effected the plant will start up.

**I Will Instruct You**

How to tell genuine PEARLS from imitations for 25 cents.

**I. BROADBENT,**

No. 4 So. 42d St., Philadelphia.

**G. B. BARRETT & Co.,** 101 FIFTH AVE., PITTSBURG, PA.  
... JOBBERS IN ...  
**WATCHES, DIAMONDS AND JEWELRY,**

STRICTLY WHOLESALE.

We invite special attention to our very large and complete stock.

DIAMONDS, Loose and Mounted, a Specialty.



**..THE LATEST..**

**Sterling Silver Novelty,**

**CIGAR CUTTER**

**AND KEY RING COMBINED.**

Patented Nov. 20th, 1894.

WITH OR WITHOUT CHAIN.

MADE ONLY BY

**ENOS RICHARDSON & CO.,**

23 Maiden Lane, New York.



# CLASSIFIED INDEX TO ADVERTISEMENTS.

All Advertisements are entitled to one insertion under proper heading. Extra insertions, \$6.00 per annum  
Extra Headings, \$12.00 per annum.

	Page.		Page		Page.
<b>Art Pottery, Bric-a-brac, Etc.</b>		<b>Ebony Goods.</b>		<b>Sample Trunks.</b>	
Borgfeldt, Geo. & Co., 18 20 & 22 Washington Place New York.....	Front Cover	Provenzano, J. N., 39 Union Square, N. Y.....	31	Crouch & Fitzgerald, 161 Broadway, N. Y.....	5
Bing, Ferdinand & Co., 106 Grand St., N. Y.....	64	<b>Enamellers.</b>		<b>Show Cases.</b>	
Bradley & Hubbard Mfg. Co., Meriden, Conn	67	Wild, S. S. & Son, 179 Eddy St., Providence, R. I.....	68	Smith, B. & W. B., 220 W. 29th St., N. Y.....	72
Glaenger, Leon J. & Co., 80 & 82 Chambers St., N. Y.....	3	<b>Fine Stationery.</b>		<b>Silver Plated Ware.</b>	
Healey, M. & E., Washington, D. C.....	71	Parsons & Greene Co., 18 Murray St., N. Y....	5	Adelphi Silver Plate Co., 62 John St., N. Y....	38
Hinrichs & Co., 29 & 31 Park Place, N. Y.....	71	<b>Gold and Rolled Plate Jewelry.</b>		Bell, O. E. & Co., 51 E. 4th St., Cincinnati O.....	1
Leonard, P. H., 76 & 78 Reade St., N. Y.....	67	Foster & Bailey, Providence, R. I.....	26	Homan & Co., Cincinnati, Ohio.....	52
Le Boutillier & Co., 860 Broadway, N. Y.....	33	Smith, Wm., & Co., 5-7 Maiden Lane, N. Y....	71	Pairpoint Mfg. Co., New Bedford, Mass. . . .	5
Levy, Dreyfus & Co., 9 & 11 Maiden Lane, N. Y.....	43	<b>Gold and Silver Platers.</b>		Rogers & Bro., 16 Cortlandt St., N. Y.....	23
Straus, L. & Sons, 42 to 48 Warren St., N. Y....	63	Newman, O., 75-77 Nassau St., N. Y.....	44	The Wm. Rogers Mfg Co., Hartford, Conn... 5	
Vantine, A. A. & Co., 877 & 879 B'way, N. Y.	66	<b>Gold Jewelry.</b>		Webster, G. A., Chicago, Ill.....	51
<b>Assayers &amp; Refiners.</b>		Aikin, Lambert & Co., 19 Maiden Lane... 10-63		<b>Sterling Silver Novelties.</b>	
Baker, Geo. M., Providence, R. I.....	14	Carter, Sloan & Co., 15 Maiden Lane, N. Y....	61	Codding Bros. & Heilborn, North Attleboro Mass.....	20
Le Long, L. & Bro., Newark, N. J.....	72	Cross & Bequelin, 17 Maiden Lane, N. Y.....	20	Hagan, White & Co., 243 W. 23d St., N. Y....	69
U. S. Smelting & Refining Works, 25 John St., N. Y.....	72	Durand & Co., 44 East 14th St., N. Y.....	39	Kent & Stanley Co., Providence, R. I.....	28-29
<b>Auctioneers.</b>		Hedges, A. J. & Co., 6 Maiden Lane.....	69	Provenzano, J. N., 39 Union Square, N. Y....	31
Boyle, Davis & Goodman, 63 5th Ave., N. Y., 611 Pennsylvania Ave., Washington, D. C....	70	Marcy, Fred. I. & Co., 59 Page St., Providence R. I.....	58	Richardson, Enos. & Co., 23 Maiden Lane....	45
Comrie, A. J., 22 John St., N. Y.....	70	Schwartz, W. H., & Co., Newark, N. J.....	60	Royal Silver Novelty Co., 470 Broadway, N. Y	32
French, J. H., P. O. Box 2775, N. Y.....	14	<b>Gold and Silver Novelties.</b>		<b>Sterling Silverware.</b>	
H. M. Rich & Co., 21 School St., Boston, Mass.....	62	Riley, John A., & Sloan Co., Ltd., Broadway and 17th Street.....	69	Campbell-Metcalf Silver Co., Providence, R. I.	71
<b>Brownie Novelties.</b>		Reddall, John W. & Co., Newark, N. J.....	19	Fuchs, Ferd. & Bros., 808-810 Greenwich St., N. Y.....	18
Griffith, R. L. & Son, 129 Eddy St., Providence, R. I.....	71	Sweetland Bros., North Attleboro, Mass.....	20	Shiebler, G. W. Co., 179 Broadway, N. Y....	20
Wm. Kendrick Sons, Louisville, Ky.....	48a	Waite, Thresher Co., Providence R. I.....	14	Towle Mfg. Co., Newburyport, Mass.....	28, 71
<b>Badges, Medals, Etc.</b>		<b>Guards, Scarf Pins.</b>		Wallace, R. & Sons Mfg. Co., 3 Park Place, Wood & Hughes, 16 John St., N. Y.....	6
Stockwell, E. R., 19 John St. N. Y.....	70	Security Mfg Co., 7 Astor House, N. Y.....	60	<b>Spectacle and Eyeglass Cases.</b>	
<b>Carborundum.</b>		<b>Horological Schools.</b>		White, W. B. & Son, Boston, Mass.....	63
The Carborundum Co., Monongahela, Pa.....	70	Chicago Watchmakers' Institute, Chicago, Ill.	51	<b>Thimbles.</b>	
<b>Chains.</b>		Parson's School for Watchmakers, Peoria, Ill.	51	Ketchum & McDougal, 198 Broadway, N. Y....	63
Hamilton & Hamilton Jr., P. O. B. 754, Providence, R. I.....	Back Cover	Philadelphia College of Horology, 623 Heed Building, Phila., Pa.....	62	<b>Tortoise Shell Goods.</b>	
Kent & Stanley Co., Providence, R. I.....	24 25	<b>Insurance.</b>		Potter, W. K., Providence, R. I.....	67
<b>Clocks, French, English and American.</b>		Fidelity & Casualty Co., 140-146 Broadway....	14	Rice & Hochster, 415 Broadway.....	12
Jacques, Chas., Clock Co., 22 Cortlandt St., N. Y.....	72	<b>Jewelry, Silverware and Optical Cases.</b>		Glickauf & Newhouse, 84 & 89 State Street, Chicago, Ill.....	57
<b>Cut Glass.</b>		Jackson, S. C., 180 Broadway, N. Y.....	67	<b>Tool Manufacturers and Dealers.</b>	
Clark, T. B. & Co., 860 Broadway, N. Y.....	69	<b>Jobbers, Watches, Diamonds, Etc.</b>		Allen, Benj. & Co., Chicago, Ill.....	15
<b>Diamond &amp; Precious Stone Importers.</b>		Allen, Benj. & Co., Chicago, Ills.....	15 51	Aikin-Lambert Jewelry Co., 19 Maiden Lane	10-63
Disselkoben, John N., 19 E. 16th St., N. Y..	61	Barrett, G. B. & Co., 101 5th Ave., Pittsburg, Pa.....	45	Brethauer Watch and Jewelry Co., Chicago, Ill.	51
Falkenau, Oppenheimer & Co., 40 Maiden Friedlander, R., L. & M., Ltd. 30 Maiden Lane, N. Y.....	72	Heeren Bros. & Co., Pittsburg, Pa.....	45	Myers, S. F. & Co., 48 Maiden Lane, N. Y....	72
Hedges, Wm. S. & Co., 170 Broadway, N. Y....	60	Oppenheimer Bros. & Veith, 35 Maiden Lane, N. Y.....	34	Schroder, D. & Co., 252 Race St., Cincinnati, O.....	54
Kahn, L. & M. & Co., 172 Broadway, N. Y....	72	Sproehle, F. M. & Co., Chicago, Ill.....	53	<b>Musical Boxes.</b>	
Kipling, E. E. 182 Broadway, N. Y.....	72	Cuendet, E. L., 21 John St., N. Y.....	18d	Jacot & Son, 39 Union Square, N. Y.....	10-67
Kipling, R. A., Hays Bldg., N. Y.....	60	Wolfe, A., 194 Broadway, N. Y.....	59	<b>Ophthalmic College.</b>	
Lorsch, Albert & Co., 37 Maiden Lane, N. Y.	72	St. Louis Ophthalmic College, St. Louis, Mo... 51		<b>Optical Goods.</b>	
Nissen Ludwig & Co., 18 John St.....	60	Berger, Albert & Co., 47 Maiden Lane, N. Y..	5	Geneva Optical Co., Chicago, Ills.....	51
Randel, Baremore & Billings, 29 Maiden Lane Smith, Alfred H. & Co., 182 Broadway, N. Y..	61	Queen & Co., Philadelphia, Pa.....	72	Spencer Optical Mfg. Co., 15 Maiden Lane, N. Y.	48a
Tannenbaum, L., & Co., cor. Maiden Lane and Nassau St., N. Y.....	37	<b>Pens, Pencils, etc.,</b>		Aikin, Lambert & Co., 19 Maiden Lane, N. Y.	10-63
<b>Diamond Cutters.</b>		Diamong Point Pen Co., 7 Astor House' N. Y.	32	LeRoy, Fairchild & Co., 3 Maiden Lane.....	15
Arnstein Bros., 45 John St., N. Y.....	18	Smith, H. M. & Co., 83 Nassau St.....	9	<b>Ring Makers.</b>	
Fox Bros. & Co., 68 W. 4th St., Cincinnati, O.	30	<b>Safes.</b>		Bowden, J. B. & Co., 192 Broadway, N. Y.....	58
Stern Bros. & Co., Cor. John & Nassau St., N. Y.....	39	Mosler, Bahmann & Co., 518 B'way, N. Y....	63	Bryant, M. B. & Co., 10 Maiden Lane, N. Y..	48
<b>Diamond Jewelry.</b>				Haskell, H. C., 11 John St., N. Y.....	48
Fox, Gustave & Co., 148 W. 4th St., Cincinnati, O.....	55			Hildreth Mfg. Co., 53 Maiden Lane, N. Y....	69
Jeanne, Paul, Bradley Bldg., N. Y.....	10			<b>Sample Trunks.</b>	
Leonhardt & Curran, 44 1/2 Maiden Lane, N. Y.	48d			Crouch & Fitzgerald, 161 Broadway, N. Y.....	5
Schwab, A. G. & Bro., 61 W. 5th St., Cincinnati, O.....	54			<b>Watch Manufacturers.</b>	
<b>Diamond Polishing Mills.</b>				A. C. Smith Watch Co., 177 Broadway ... 32-48d-49	
Arthur Co., The, 86 John St., New York....	44-72			The E. Howard Watch and Clock Co., Maiden Lane.....	2
<b>Display-Window.</b>				Trenton Watch Co., Trenton, N. J.....	59
Pearce, Frederick, 77-79 John St., N. Y.....	68			<b>Watch Case Manufacturers.</b>	

## Special Notices.

Rates 75c. per insertion for notices not exceeding 3 lines (25 words); additional words 2 cents each. If answers are to be forwarded, postage stamps must be enclosed. Two insertions, 15 per cent. off; three insertions, 20 per cent. off; four insertions or more, 25 per cent. off. Payable strictly in advance. Display cards on this page will be charged at \$2.00 per inch for first insertion, subject to same discount as above for subsequent insertions.

Under the heading of **Situations Wanted** on this page advertisements will be inserted for One Cent a Word. This offer refers to **Situations Wanted only**. Payable strictly in advance. If answers are to be forwarded, postage must be enclosed.

## Situations Wanted.

*Notices under this heading ONLY are charged at one cent a word, payable strictly in advance. If answer are to be forwarded, postage must be enclosed.*

BY an American watchmaker, jeweler and salesman with complete set of tools and eight years' experience. Best reference Address Reliable, Box 202, Station A, Meriden, Conn.

WANTED.—A steady position by a first-class watchmaker. Twenty years' experience. Have my own tools. Best of references. A. L., care of JEWELERS' CIRCULAR.

SITUATION wanted by a young lady in the business department of either watch, jewelry, silver or kindred trades. Several years' experience. First-class references. New York or Newark preferred. Address C. T. M., care of JEWELERS' CIRCULAR.

WANTED, a position as expert watchmaker. Experience of 20 years of fine and complicated watches. Best of references. Address Adjustino, care JEWELERS' CIRCULAR.

ENGRAVER and designer A1, wishes to make an engraving January 1st, 1895. Address Engraver, care JEWELERS' CIRCULAR.

POSITION wanted by a first-class watchmaker. Full set of tools. Eighteen years' experience on fine and complicated work. Address C., care JEWELERS' CIRCULAR.

WANTED, by a practical jeweler. Experienced foreman and designer, especially diamond work, wishes a position by Jan. 1st. Address A. B., care JEWELERS' CIRCULAR.

WATCHMAKER wants situation, eight years' city reference. Moderate salary. Archard, 229 W. 38th St., New York.

BY an American watchmaker and jeweler. Plain letter engraver, salesman, stockkeeper; 12 years at bench; 28 years of age; single; moderate salary. Address H., care John Burgess, Bloomfield, Iowa.

EXPERIENCED TRAVELER would like to represent an eastern manufacturer, Jan. 1st. Address Traveler, care H. B. Peters, 177 Broadway, New York.

BOOKKEEPER, absolutely reliable and competent to take charge of office, credits and collections, desires to make a change: for number of years in similar position in watch and diamond line; excellent references. Address Amiable, 170. Care JEWELERS' CIRCULAR.

YOUNG Irishman wants a situation as watch and clockmaker; wages no object; a start required. Address "Watclock," care JEWELERS' CIRCULAR.

POSITION desired by young man of good address and ability, where 12 years' business experience and acquaintance with New England, Middle States, and southern jewelry trade will enable him to advance; highest references. W. A. L. S., P. O. Box 1276, New York.

SALESMAN; thoroughly acquainted with western jewelry trade, jobbing and retail, wishes to make a change Jan. 1, have been with present house eight (8) years. Address X., JEWELERS' CIRCULAR, 189 Broadway.

## Help Wanted.

WANTED—Letter engravers on silverware. State experience and wages expected. Address B. C., care JEWELERS' CIRCULAR.

WANTED, salesman, thoroughly acquainted with the large retail trade in the East and Middle States. Must be posted in the watch line. Address B. B., care JEWELERS' CIRCULAR.

WANTED, young man for manufacturing badges and repairing. One who wishes to improve and learn to do first-class work; can have good advantages; steady work at moderate price. Address The George H. Ford Co., New Haven, Conn.

A TRAVELING salesman to handle a first-class line of jewelry on commission in New York State, Pennsylvania, Ohio or any one or two of the three, calling on the legitimate jewelry trade only in connection with his present line. Address T. 74, care JEWELERS' CIRCULAR.

WANTED at once first class watchmaker and salesman, fair engraver, good appearance and habits. Send photo and references in first letter. Industrious, all-round man can get steady position; single man preferred. P. M. Childress & Co., Valdesta, Ga.

WANTED—Young man experienced in tools, materials and optical goods; references. Address 1894, care THE JEWELERS' CIRCULAR.

WANTED—Watchmaker and engraver; give reference and wages wanted. Address H. M., care JEWELERS' CIRCULAR.

FIRST CLASS designer for manufacturing jeweler in Newark. Address, with references, M. Z., care JEWELERS' CIRCULAR.

## Miscellaneous.

WANTED—Second hand balance for gold; capacity 300 ounces each pan. Address V. S. M., care JEWELERS' CIRCULAR.

FOR SALE OR EXCHANGE—One Barnes foot lathe with all attachments, also universal slide rest and cutters, length of bed 34 inches; one new muffled gas enameling oven, never used; one W. W. Oliver hand press punch with plates and punches never used. Will swap for jewelry material or anything I can use; will sell one-third off manufacturing prices. C. E. Blue, Atlanta, Ga.

## For Sale.

ASTRONOMICAL Telescope, 3½ inch glass, value \$150. Will exchange for diamonds or jewelry. Full description sent. Address Manufacturer, 940 Ave. D., Bayonne, N. J.

FOR SALE—Fine set of watchmaker's tools, "Comfort" watch glass case with full assortment of glasses, Whitcomb lathe, roll top bench, cost \$325; will sell for \$150. Address Box 2621, West Chester, Pa.

FOR SALE—Tools, fixtures and machinery of a manufacturing jeweler; can be seen in working order. Address King & Co., 355 Mulberry St., Newark, N. J.

FOR SALE—Jewelry store established 36 years in one of the best business streets in Troy. Reasons for selling wish to settle estate. Further particulars address Mrs. E. H. Platt, Troy, N. Y.

## Business Opportunities.

JEWELRY and optical business, 20 years' standing. Best street in Chicago; stock and fixtures, about \$5,000. Can reduce to suit. Have three places, want to sell two and run one right. Good chance for good man. Address Optician, 70 Madison St., Room 11, Chicago, Ill.

A RARE OPPORTUNITY—For sale in one of the prettiest and best towns of the Connecticut valley, a jewelry and stationery store combined or either department sold separate if so desired. It is an old established business of 35 years. A good stock, in fine condition, the best of location with comparatively no competition in a town of 5,000 inhabitants; fixtures in first class shape; both branches of business would require from \$8,000 to \$9,000; could be reduced considerably if necessary; jewelry department about three-fourths of whole cost. Reasons for selling going into the manufacturing business. Best of references if requested. Address Chance, care JEWELERS' CIRCULAR.

## A RARE OPPORTUNITY

To Buy at a bargain Fixtures and Lease of a 16 years established Jewelry Store on the leading avenue up town in New York City.

Owner retiring from business wishes to close out his Stock of Diamonds, Watches, Jewelry and Silverware before January 1st.

Sales have averaged the last five years from \$16,000 to \$20,000, and the amount of repairing from \$3,000 to \$4,000 yearly.

Good reference given.

Address A. A., care Jewelers' Circular.

## DIAMOND CUTTING WORKS FOR SALE

12 Mills down-town, most improved, entirely new machinery, good light, could give possession at once. Rent of premises reasonable.

APPLY TO

## THE ARTHUR CO.

86 John Street, New York.

DESK ROOM TO RENT—In Columbus Memorial Building, State and Washington Streets, Chicago. Address, X. Y., care JEWELERS' CIRCULAR, Western Office, 517 Inter-Ocean Building.

## WHEEL CUTTING.

We make a specialty of Wheel Cutting, Demagnetizing and Watch Repairing for the trade. Complete plant. Send for price list.

## THE WINSLOW & PENNEY CO.

608 Masonic Temple, - CHICAGO.

## I Will Instruct You

How to tell genuine PEARLS from imitations for 25 cents.

## I. BROADBENT

No. 4 So. 42d St., Philadelphia.

## THE SPECIAL

COLUMNS

— OF THE —

## Jewelers' Circular

Bring Better Results for a Small Outlay of money than any medium in the Jewelry Trade.

TRY THEM.

THE NOTICE

Hiram Ferguson, 822 Grape St., who has sold jewelry throughout the country districts for many years, committed suicide last Monday morning at his home by shooting himself in the right temple. He was ill and despondent. Mr. Ferguson was 51 years old and had been a resident of this city for 28 years. He leaves a wife and five children.

Henry Morris, who was arrested in Troy on the charge of attempting to steal a diamond ring from the jewelry store of M. Timpane and also with attempting a "flim flam" game in the jewelry store of E. Marks, was brought to this city on Tuesday last by Detective Sheppard. He was thought to be the man who stole the diamonds from Becker & Lathrop, on Oct. 17th, and also \$4,000 worth of jewelry in Utica on the Monday preceding. Mr. Lathrop failed to identify the man, however, and he is being held at police headquarters until his record can be investigated. If nothing is proven against him here he will be taken back to Troy to answer the charge of larceny brought against him in that city.

#### The Jewelers' Fifteen Puzzle.

All the jewelers in Chicago arose and tore their hair one Sunday morning when they read the advertisements and saw that a big dry goods house advertised a certain brand of watches for sale at \$10.

"Now," they shouted, "trickery! treason! Why, we have to pay the manufacturers \$12 ourselves at wholesale! Can these things be?"

Then they sat down and wrote various furious letters to the manufacturers accusing them of underselling to this particular dry goods store. "We won't stand it!" they sobbed in postscript.

"We didn't sell them cheaper!" howled back the manufacturers, hotly in type-written characters.

Then a rival watch manufacturer plunged into the sizzling arena with a circular to all the abused Chicago retailers in the jewelry line, wherein he lamented and remarked on the perfidy of certain manufacturers who coquetted falsely with two prices and played it low. "Come, oh, come with me," he advised. "To thee I will be true."

And all this anguish and suspicion and waste of paper was caused by the dry-goods house choosing to sell the watches for less than cost simply to draw trade.

But what puzzles and incidentally annoys the jewelers and druggists and grocers is what department it is in which these combination stores make enough money to enable them to sell for less than cost in all the other departments. It is as bad as a thirteen puzzle.—ELAINE GENET in Chicago *News*.

Opera glasses and holiday trade have become synonymous terms. Jewelers who have not placed orders for their opera glass stock should notice the advertisement of Queen & Co., Philadelphia, Pa., on another page. They state that selection packages will be sent to any reputable dealer.

#### Industrial Notes.

Deutsch Bros., 7 E. 17th St., New York, are receiving orders daily for goods illustrated in their catalogue. They cheerfully forward these fine books to the legitimate trade.

The young and enterprising firm of Sweetland Bros., North Attleboro, Mass., show an excellent and salable line of novel ties in hair, stick and hat pins, link buttons, etc., etc. The designs are taking and the prices at which they are offered make the goods quick sellers.

We doubt very much if there is a jeweler in this country but what will find that he will be cramped for room to display what stock he may want to carry during the holiday season, which fact only emphasizes that the old time way of showing goods does not meet with all emergencies; and the many houses who have long used the Fletcher Patent System still continue to add to it in some of its various forms, thereby proving the way out of all difficulties—being able to handle and show more goods in one-third the time.

A good selling specialty is to be found in the gold pen line in a fan shaped easel tray containing one dozen pens and pearl holders. These are sold at the very low price of \$9 for the entire lot, and are outselling anything before offered in this line. H. M. Smith & Co., 83 Nassau St., New York, are receiving orders for these from all parts of the country. An illustration of the tray and goods is to be seen on another page of this issue. The firm's new catalogue has just been issued and is very complete. Dealers should send for a copy.

Thomas W. Lind, Providence, R. I., shows on another page of few of his latest offerings in Czarinas. The popularity of Mr. Lind's goods was well attested from the fact that his recent handsome double page display in THE CIRCULAR brought him orders from all over the country, some even coming to him from Europe. In the manufacture of trimmings Mr. Lind claims to be the leader. Experienced die cutters and designers are constantly producing something artistic and his prices make competitors few. Write for a sample sheet.

A timely and novel conceit is the Brownie cup here shown, manufactured by Homan

& Co., Cincinnati, O. This cup represents eight of Palmer Cox's leading sprites, the Irishman, Dutchman, Policeman, Dude,



Scotchman, Indian, Russian and the Major. Each Brownie is in relief and the characteristic features are faithfully portrayed, even the legs and feet, which Palmer Cox has said no one could imitate, being true reproductions of the originals. As a piece of fine die work, we consider the Brownie cup an eminent example. It has already received many substantial compliments.

#### Artistic Conceptions in Sterling Silver Table Ware.

WE illustrate elsewhere one of the richest patterns both in design and in execution ever offered in sterling silver table ware. In their Trajan, the manufacturers, Reed & Barton, Taunton, Mass., have combined many of the best decorative features of the artist minds which have been applied to the subject. In appearance, massive, yet graceful, the scrolls, the flowers and the reeding all produce an harmonious whole which received the instant endorsement of silver buyers. The approximate weights of the various pieces are specified beneath each illustration and heavier weights may be had on order. Trajan fancy pieces in stock number over 100 pieces, each artistic in conception and fitted for the purpose intended. In this category are included all the latest ideas in modern table service.

In the companion pattern, La Reine, Reed & Barton have one of the most popular patterns ever handled by the trade. For excellence of workmanship the manufacturers claim La Reine stands without a peer. The design stands clearly out in high relief and its beauty is apparent from a casual inspection of the engravings. A complete line of fancy pieces in this pattern is also carried in stock and heavier weights in the line are made on order.



#### A FEW THINGS YOU WILL HAVE CALLS FOR.

UMBRELLA STRAPS.  
UMBRELLA CLASPS.  
HAT PLATES.

KEY RINGS.  
SNAKE RINGS.  
STONE RINGS.

#### ORAZZLE DAZZLE PUZZLE RINGS.

BOOK MARKS.  
CZARINAS.

EYEGLASS CLEANERS  
ETC., ETC., ETC.

HENRY C. HASKELL, Maker, 11 John Street, N. Y.

**Boston.**

Henry C. Cady, of the American Optical Co., was among the callers upon the Boston trade last week.

A. A. Abbott, manager of Smith & Patterson's Montreal establishment, was in Boston the past week.

The E. Howard Watch & Clock Co. will equip the State House extension with fine clocks for the halls of legislation.

By the will of the late Francis Buttrick, of Waltham, the watch city will receive nearly half a million dollars in public bequests.

Joseph C. Davis, who died Nov. 23, was in his younger days known to the trade as a jewelry manufacturer, but of late years had conducted a banking and loan business on School St. He was 70 years of age.

Buyers from a distance in town last week included: C. B. Duckworth, Pawtucket, R. I.; Mr. Curtis, of Curtis, Rand & Co., Contoocook, N. H.; Pollard Bros, Proctorsville, Vt.; Merritt Welch, Norway, Me.; Mr. Flint, of Flint Bros., St. Johnsbury, Vt.

An unsuccessful attempt was made to break into Keene's jewelry store, 1301 Washington St., last Tuesday night. Mrs. Keene was sitting in the window early in the evening when a man rushed across the street with a brick wrapped up in a newspaper. He made a smash at the window with the brick, while his followers attempted to run a stick through the door handles to keep the clerks in. The man did not strike hard enough to break the glass. A pistol is kept by the window, and this in the hands of a clerk scared the gang from the door before any harm was done.

**Pittsburgh.**

A. Kingsbacker is on a western trip, and will be out for a couple of weeks.

Charles N. Wattles and J. C. Grogan have returned from their eastern trips.

Wm. McCormick has recently opened up

a new store over G. B. Barrett & Co.'s place.

Harry Heeren, Albert Heeren and George Showers left last week on a three weeks' hunting trip.

Miss Clara Heeren and John Neisser have lately been enrolled on Heeren Bros. & Co.'s staff of employes.

W. F. Brehm, a well-known jeweler, has started up anew in Rochester, Pa., with a fine stock lately purchased here.

The Diamondtine Jewelry Co. have started up at 137 Fifth Ave. with a capital stock of \$10,000. Louis Selezwick will be manager of the concern.

The banquets of the Western Pennsylvania Consistory and of the Mystic Shriners on Thursday and Friday nights of last week were largely attended. Prominent among the knights was S. F. Roberts.

G. B. Barrett & Co. and their many clerks have been kept busy during the last few weeks running day into night. The present rush of work augurs auspiciously for a fine holiday trade.

The factory employes of Heeren Bros. & Co. are now engaged in transferring the

remains of the famous old Arsenal cannon into a miniature cannon to be placed in the Carnegie Library Museum.

Henry Terheyden entered suit Nov. 20th against Charles Scheib, of Aspinwall, to recover the price of two diamonds valued at \$500 which the defendant is alleged to have fraudulently appropriated on Nov. 24, 1892. A capias was issued and bail fixed at \$300.

Visiting jewelers during last week were: George C. Hayes, Morgantown, W. Va.; F. C. Hayes, Washington, Pa.; A. A. Poole, Washington, Pa.; F. H. Marshall, Derry Sta.; C. Springer, New Castle, Pa.; D. L. Cleland, Butler; Harry Janowitz, Johnstown and W. J. Lukens, Wheeling, W. Va.

Sheriff Ingram was the defendant in a case in Common Pleas Court in West Chester, Pa., Nov. 22d, brought by August Kruger, jeweler, Phoenixville, who charges that the Sheriff illegally levied upon his goods in January last, which action so shattered his nerves and undermined his health that he has lost much of his business in consequence. He fixed damages at \$2,000 and was awarded \$1,000.

**"BROWNIES"**



Have become very popular through the medium of the "Ladies' Home Journal" and the "St. Nicholas." The following illustration is a reproduction of a Souvenir Coffee Spoon designed by a Louisville lady and controlled by



**WM. KENDRICK'S SONS, Jewelers,**

336 4th Avenue, Louisville, Ky.

PRICES: Coffee Spoon, Plain, \$2.00; Gilt Bowl, \$2.25; all Gilt, \$2.50. Discount to Jewelry Trade. **SPECIAL:** Upon receipt of \$1.50 Spoon will be sent as sample.



Just Received Our Fall Importation.

**THE AUDEMAIR OPERA GLASSES,  
SPENCER OPTICAL MFG. CO.,  
15 MAIDEN LANE, NEW YORK.**

CALL OR WRITE. IT WILL DO YOU GOOD!

**ONE OF THE 400, AND VERY SWELL INDEED.**

**THE PERFECT FIT OF OUR No. 918 GOLD EYE GLASS, SWELL END EYE WIRE.**

Our Ambition to Make a **FAULTLESS GOLD SPEC.** and Eye Glass has been realized, and is appreciated. Strength and Beauty Joined Together **WITHOUT SOLDER.** You "see that hump" no longer. It's gone, and in its place, at ends and bridge, you find that **GRACEFUL SWELL,** as shown in cut. *This is the Modern and Perfect Frame the public are asking for, made in all weights, sizes, shapes and qualities.*

**WE MAKE ALL KINDS OF OPTICAL SPECIALTIES, AND TEACH HOW TO GET BEST RETURNS IN HANDLING THEM.**

The Best Made for the Least Money. Also Cheaper Grades. The Greatest Variety of Styles. Great Reductions to Correspond with New Tariff and Other Causes. **SEND FOR NEW SUPPLEMENT.**



## ADVERTISING HINTS FOR RETAIL JEWELERS.

BY CHARLES AUSTIN BATES.

The Editor of THE JEWELERS' CIRCULAR has asked me to contribute a series of articles on retail jewelry advertising.

It is my desire to make these articles as useful as possible and to that end, an invitation is extended to retailers to send to me any of their advertisements which they would like to have criticised. It may be that there are some questions which they will care to ask and that I can answer.

Each week I will give several examples of advertising, which will illustrate my ideas on the subject. I do not present these advertisements with the claim that they are perfect, but only with the hope that they will contain some useful suggestion, and that some dealer at least will find that by making slight changes in them, as local conditions require, they will be able to make use of them, and so relieve themselves of one detail of their business.

### PART VII.

**T**HE Christmas campaign is now fairly opened, and until after the first of January, jewelry advertising should have more attention than it gets at any other time of the year.

This advertisement from Providence has good and bad features, both distinctly marked.

The style of display is all right, but the type used was entirely too black. A jewelry advertisement ought, by its appearance, to convey some suggestion of the goods. It ought to be light and pretty and dainty. Artistic illustration will help it very materially, but I am not a believer in the use of semi-comic illustrations. The illustrations should illustrate the goods, and not some catchy phrase which is used for the headline.

This advertisement of Tilden-Thurber Co.'s is good because of its suggestiveness. The list of articles may seem too general

very suggestive and helpful to those who are looking for presents, and I believe they are very effective in bringing direct small orders. Local jewelers may well pattern after these advertisements, because it is very much harder to secure an order by mail, where the money has to be sent in advance, and the goods selected from the picture, than it is to draw people into the store where they can see the actual goods.

You cannot make an advertisement too plain, and the right sort of illustrations will help. Sometimes their expensiveness precludes their use, but quite often the most expensive expense is the one that is not incurred. Sometimes it is really extravagant not to spend money.

If you have a ten dollar space in the paper, you had better spend five dollars more, if necessary, to make it attractive and effective. If the additional five dollars only influences one watch or diamond cus-

is. That is to say, if the two dollar advertisement will result in a ten dollar sale, the twenty dollar advertisement will bring more than ten times as much.

There is no use publishing an ad. that is so small nobody will see it. At the same time, I would rather have an ad. of reasonable size in a fixed and desirable position, properly illustrated and well constructed, than to have a great, big, overgrown space mixed up with a lot of other big, overgrown spaces. I would rather have a small, "swell" store on the principal corner of the town than to have a ten-story warehouse in an alley.

\* \* \*

An example of the use of too many words, and words that are unnecessary, is furnished in this ad. of Whittier's:

### WEDDING BELLS

Invite joyous greetings. Their subtle charm fascinates. They delight and satisfy as the dainty, delicate perfume of a

### FORGET-ME-NOT.

A gentle reminder from us to you for them is, when in doubt about suitable

### WEDDING

### PRESENTS

COME SEE US.

There is pleasure in surprise at the inexpensive elegance of our

### JEWELRY.

All worthy quality, in many styles, of the newest, choicest novelties, to please the eye, delight the taste, and fit every purse.

HENRY C.

### WHITTIER & SON,

327 WESTMINSTER ST.

Bag Tags  
Bangles  
Belt Buckles  
Blotters  
Bonbon Dishes  
Book Marks  
Button Hooks  
Card Cases  
Emeries  
Floss Boxes  
Flower Pins  
Garter Buckles  
Glove Buttoners  
Glove Darners  
Napkin Rings  
Orange Spoons  
Paper Cutters  
Pen Knives  
Pin Trays  
Powder Puffs  
Salts Bottles  
Scarf Pins  
Shoe Horns  
Tea Balls  
Thimbles  
Velvet Brushes

## STERLING SILVER NOVELTIES

The list gives some suggestions, but conveys no idea of the variety.

# TILDEN THURBER CO.

New designs are being added constantly to the assortment.

From 25c. to \$2.00 and upward.

Cigar Cutters  
Coat Hangers  
Collapsion Cups  
Coin Lockets  
Cork Screws  
Cuff Buttons  
Flasks  
Ink Stands  
Match Boxes  
Moustache Combs  
Nail Brushes  
Necktie Holders  
Paper Cutters  
Pen Holders  
Pencils  
Pen Trays  
Pocket Knives  
Pocket Rules  
Scarf Pins  
Scarf Holders  
Sleeve Holders  
Stamp Boxes  
Thermometers  
Tooth Brushes  
Whisks  
Whistles

and too much a catalogue of a store, but I believe it is a good idea. People are beginning to think about presents now, and the mere mention of an article is about all that is needed if it happens to strike their ideas.

A better plan than this is exemplified in the advertisements which several jewelry houses are publishing in the principal literary magazines. They contain exact representations of the articles advertised and give the price of each. They are

tomers, it will certainly be very profitable. The price of newspaper space is just the same whether the advertisement that is put into it is a good advertisement or a bad one. An advertisement that costs twenty dollars and pays, is a good deal better than an advertisement that costs two dollars and does not pay. As a general thing I believe that the twenty dollar advertisement is more likely to bring really profitable results than the two dollar advertisement

It is quite well displayed and has the advantage of readability. One sentence in this advertisement is fearfully and wonderfully made. It is the one which says: "A gentle reminder from us to you for them is, when in doubt about suitable wedding presents, come see us." There are too many words and not enough meaning in this advertisement. Whoever wrote it was burdened with the idea that he was writing an advertisement, and that he must say something smart or die in the attempt. That's the trouble with a great deal of the advertising that is written now-a-days. The writer forgets all about the point he wants to make, or the idea he wants to convey, and wastes his time and newspaper space by trying to say something cute or flowery. When an inexperienced writer commences to use similes and metaphors he is in a "pretty bad row for stumps" and had better look out a little. He had better take "Punch's" advice to those about to marry—"Don't."

**Providence.**

TRADE CONDITIONS.

The general business among the manufacturers during the past six weeks has been the best for a long time. Novelty lines have enjoyed the more marked increase and nearly every shop has been run at its fullest capacity. Makers of standard goods have experienced some improvement, as is naturally to be expected just previous to the holidays. During the past week, however, there has been a slight decrease in the amount of new orders, but generally speaking, a majority of the manufacturers have orders enough to keep running full time until the first of the year. The prospects for Spring are thought to be very encouraging.

Horace W. Steere, of Arnold & Steere, has returned from an extended and successful business western trip.

Edgar L. Richards, manufacturer of jewelry settings, has removed from 77 Somerset St. to 87 Providence St.

E. A. Woodmancy has been making a business trip through Canada in the interests of Potter & Buffinton.

By the recent failure of E. B. Schiller, New York, manufacturers in this vicinity are interested for \$5,000 to \$8,000.

The Hope Silver Mfg. Co. have opened a retail branch at 395 Westminster St., Room 1, with a line of silver holiday novelties.

J. B. Wentworth, who has been dangerously ill with congestion of the lungs, for the past ten days, has so far recovered as to be out of danger.

Charles W. Pierce, for a number of years a prominent salesman for Flint & Co., has accepted a responsible position with the Mossberg Wrench Co.

Additional bonds of \$50,000 of the guardian of the estate of Thomas Lind, was accepted and approved in the Municipal Court on Friday.

Clark Johnston, assignee of William L. Ballou & Co., is still engaged in straightening out the affairs of that concern and expects to have the schedules ready in a few days.

The Tilden-Thurber Co. have received a large consignment of the newest and most unique conception of the season, scarabæus jewelry. These peculiar patterns are destined to become a fad among the fashionables.

Henry W. Harvey, assignee of Richard Robinson & Co., has finished his inventory of the stock, etc., of the concern, and will present his schedules in a few days. A meeting of the creditors will probably be called in about a week.

**Canada and the Provinces.**

E. S. Cole, Niagara Falls, Ont., has given up business.

T. A. Simonds, jeweler, St. Thomas, advertises giving up business.

Geo. Chillas, Canadian agent for the Pairpoint Mfg. Co., is in Toronto.

W. R. Roberts, jeweler, Vancouver, B. C., is moving his stock to Nanaimo, B. C.

The Toronto Silver Plate Co. are opening up a branch establishment on St. Catherine St., Montreal.

Wm. Mills, Truro, N. S., has returned home from a three weeks' visit to New York and Boston.

P. G. Melanson, Middleton, N. S., has been ill, the result of an accident, but is now recovering.

Julian Schwob, of Schwob Bros., Montreal, has been stopping at the Rossin House, Toronto.

E. A. Skinner, representing M. S. Brown & Co., Halifax, N. S., is doing the principal cities of New Brunswick.

C. A. Olmstead, Ottawa, has taken a partner, the name of the new firm being Olmstead & Hurdman.

A. R. Harmon, manager of the Canadian branch of Robbins & Appleton, has just returned from a trip to Toronto.

R. W. Woodroffe, jeweler, Winnipeg, Mon., advertises retiring from business and selling off at reduced prices at retail.

W. J. Barr, of the Goldsmiths' Stock Co., Toronto, left for Montreal last week. He will be absent about three weeks.

F. T. Trebilcock, president and manager of the Canada Smelting & Refining Co., London, Ont., was in Montreal recently.

O. W. Coleman, representing Jas. Eastwood, manufacturing jeweler, New Glasgow, N. S., visited the firm's customers in Cape Breton last week.

W. R. Jackson, jeweler, St. Thomas, Ont., has just returned from an extended

tour in the United States and Mexico, greatly improved in health.

J. A. St. Jean, representing Alfred Eaves, Notre Dame St., Montreal is doing the Quebec district with a lot of new samples, and W. Hayes of the same establishment is drumming up the Eastern Townships.

Jobbers here are complaining of the confusion arising from so many new watch movements being put on the list, and so many old ones being reduced in price and think it about time that a new price list was issued.

Samuel Fowler, jeweler, Clinton, Ont., one of the oldest residents of that town, died recently. He was a native of Doncaster, England, and came to America when a boy. After living for many years in Chicago and St. Paul he established himself in Clinton about 20 years ago, and built up a thriving jewelry business. He was greatly respected for his upright and conscientious character. Mr. Fowler leaves two sons and one daughter.

**Syracuse.**

J. H. Morse, of Hitchcock & Morse, left Monday for an eastern trip. F. J. Hollister is looking after the firm's interests in western New York.

Burt Noble, representing Payton & Kelley, Providence, who reached Syracuse on Thursday, is confined to his room at The Vanderbilt by illness. Sympathetic traveling friends are in attendance.

The inquest into the death of Andrew H. Schilling, jeweler, of Oswego, who was killed by a train at the D. L. & W. railroad station in this city on Nov. 3d, was held at the Court House on Wednesday evening. The coroner's jury find that no one was to blame for the fatality.

**SOME OF MY LATEST :::::**

**CZARINAS**

TWO-THIRDS SIZE.



325

326

324

282

**IN SILVER, GOLD, PLATE OR BRASS.**

Send for my Specimen Sheet, showing nearly 200 Patterns of Ornaments, Trimmings, Etc., in Full Size.

**THOMAS W. LIND,**

**Jewelers' Findings,**

67 Friendship Street, PROVIDENCE, R. I.

**If  
You are  
In business  
For Profits**

You should sell  
the new

**"Princeton"  
Watch**

and not be obliged to  
compete with outsiders  
nor have your customers  
tell you prices.

**Three grades:**

16 size Nickel, Hunting  
and Open Face—15, 16  
and 17 Jewels, Adjusted,  
Patent Regulator.

**Superior to any,  
and at less price.**

**Ask your Jobber.**

Price Lists with full  
information mailed to  
regular jewelers upon  
application.

**A. C. SMITH WATCH CO.,**  
Manufacturers,

177 BROADWAY, - NEW YORK.

**Connecticut.**

N. Olsen, Bridgeport, is closing out his jewelry business.

The jewelry stock of E. N. Foote, Rockville, is being sold at auction.

P. Stevens & Co., Bristol, opened their new jewelry store Nov. 20th.

F. A. Clark, of the Winsted Optical Co., was in New York last week on business for the company.

L. P. Call, the well-known representative of Simpson, Hall, Miller & Co., was in Wallingford Tuesday last.

Samuel Yudkin, jeweler and pawnbroker, Ansonia, went to New York Friday night to buy goods for the holidays.

Samuel Barry, southern traveling salesman of the Meriden Britannia Co., was in Meriden for a few days' visit last week.

The new silver company of Glastonbury have adopted the name, Eagle Sterling Company, and are turning out some goods.

The Wilcox Silver Plate and Miller Bros. Cutlery companies, Meriden, report good business and that they are running full time every day.

C. Rogers & Bros., silver plate factory, Meriden, are working full time and occasionally have to work evenings to catch up with their trade.

Corporation return: New Haven Clock Co., capital \$500,00; real estate, \$210,000;

personal estate, \$559,700; debts, \$507,800; credits, \$206,300.

George J. Strobel, of Waterbury, has just returned from a seven weeks' trip through the west in the interest of the Waterbury Watch Co.

The E. A. Bliss Co. report that they are working until 9 o'clock at night in nearly every room, and state that large orders are being constantly received.

Joseph E. Cary died at his home in Danbury, Nov. 16, of consumption aged 21. In 1892 he went to Chicago to take a position as bookkeeper in C. D. Peacock's jewelry store.

A fire at the Winsted clock factory late Friday afternoon was subdued by the fire apparatus of the factory and the use of hand grenades. The factory fire brigade did good service.

By the giving way of water pipes at the Waterbury Watch Co.'s factory Thursday, the cellar and basement rooms of the main building were flooded before the water could be shut off. The accident happened in the night.

John H. Lee, assignee, began Saturday, Nov. 24, a sale at auction under order of the Probate Court of the stock of goods of jeweler J. J. Dunlap, of Bridgeport, insolvent debtor. Charles Lee officiates as auctioneer. The sale is for closing the estate.

Major C. H. Case, the Hartford jeweler, who designed the medal for bravery issued by the Connecticut Humane Society, has made fifty-three of the medals, and they are now in the hands of the society managers to be awarded from time to time to persons in the State who have distinguished themselves by an act of heroism in saving life.

Charley Smith, formerly of Peru, Ind., has decided to locate at Huntington and engage in the jewelry and china ware trade.

George Oberlin has moved his gallery and jewelry store from Hudson, Ind., to Montpelier.

**MUSICAL BOXES**

FACTORY AT AUBERSON, SWITZERLAND.  
ESTABLISHED 1828.

**E. L. CUENDET, 21 John Street, New York City.**

Send our New Illustrated Catalogue for 1894, containing Full Particulars and Price Lists.

**HAVE YOU RECEIVED OUR PRICE LIST?  
OF DIAMOND MOUNTINGS.**

If not, send your business card and we will send you one.



Manufacturing Jewelers.  
OFFICE AND FACTORY,

**LEONHARDT & CURRAN, 57 Maiden Lane, New York.**

THE AMERICAN KNIFE AND  
SCISSORS SHARPENER.

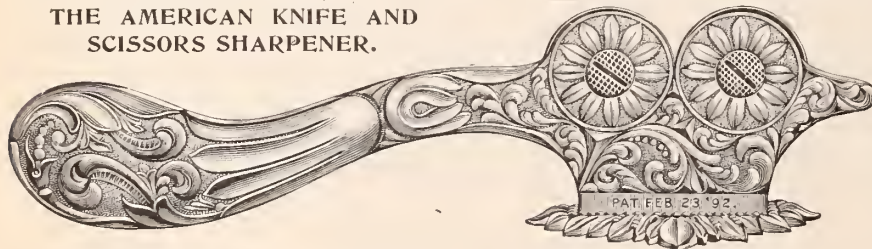

TWO-THIRDS SIZE.

**Special Inducements to Jobbers**

... Manufactured only by the **MOSSBERG WRENCH CO.,**

ATTLEBORO, MASS.

MAKERS OF

Novelties in Silver and Hardware.

**Practical and Handsome.**

A Silver Plated Knife and Scissors Sharpener, retailing at a popular price. Perfect in action, nothing to wear out. Cutting discs of finest hardened steel. An ordinary sharpness or a RAZOR EDGE can be acquired in a few moments.



TWO-THIRDS SIZE.  
FOR DESK USE.



## Fashions in Holiday Jewelry and Silver Novelties.

### A LADY'S RAMBLES AMONG THE JEWELERS.

No manifestations in the way of jewelry are so dainty and poetical as those of the brooch.

Imagine a circlet made of tiny butterfly wings brilliant with color and separated by tiny gems.

If the jewelers' windows speak true stick pins and hat pins will be the popular offerings this season.

A little silver spoon which shuts up as pocket scissors are made to do is a new device for filling a pipe.

Wreaths supported on long pins are used for hats. Another favorite design is branching rays each supporting a pearl.

Perforated bulbs, stained with enamels, are among the new designs. Others have little upright sections of enamel overlaid with ornament and joined together.

The round brooches take the form of wreaths, and these wreaths are so varied, beautiful, and of such exquisite workmanship that nothing prettier has been seen in a long time.

A beautiful necklace seen has four rows of small pearls caught together every inch or so by pierced emeralds. The medallion is flat and covered with tracery in which are sunk colored stones.

The filigree bon-bon spoons that are got out for the holidays are the prettiest things imaginable. The newest designs are in

silver gilt touched with colored enamel, and enamel flowers wreathing the handles.

A brooch of white enamel leaves with pearls as berries would make an ideal ornament for a bride. Black ivy leaves separated by pearls is intended for mourning. A holly wreath with ruby berries is a fascinating emblem of the approaching season.

The back combs keep their importance. A novelty was seen in amber shell in which the moon and stars were inlaid with diamonds. Intersecting lines in the Italian style, with ornamental foliations introduced in the center, and the edges unmounted combine in the newest designs.

Hat pins arrive at the dignity of such important articles of dress as brooches and bracelets. The new designs are bewildering in their variety. Swords, mace crooks, mitres, all the emblems of civil and military authority, are suborned to fasten on those wonders of beads and lace that women call bonnets.

A new drapery pin constructed on the principle of the sheathed sword with chain connecting the two parts, takes the form of a flower with a long stem and a few leaves. The stem has the waving lines of a tendril, and the counterfeit of nature is excellent. A number of flowers with jeweled centers are produced in these new pins.

Dressing cases suitable for the marriage season have all the implements mounted in ivory with medallions of beautiful dames framed in silver gilt and applied to the back. It would be impossible for women

with long hair to use these or any brush so ornamented as the raised parts would catch in the hair. No woman would, however, decline such a gift for any such trivial reason.

ELSIE BEE.

## Minneapolis and St. Paul.

N. P. Frederickson, Minneota, Minn., is advertising jewelry business for sale.

E. W. Storer, Minneapolis, moved to California with his family last week.

E. C. Bennett, Red Wing, Minn., has gone to Pine Island, Minn., and will open up for business there the present month.

Out-of-town jewelers visiting the Twin Cities recently were: Tom Kibbee, Drayton, N. Dak.; M. L. Madsen, Jamestown, N. Dak.; Mr. Larson, Belgrade, Minn.; E. C. Bennett, Red Wing, Minn.

Eastern jobbers and manufacturers represented in the Twin Cities recently were: O. W. Bullock & Co., by C. L. Ferre; Simpson, Hall, Miller & Co., by W. F. Adams; A. Goldsmith & Son, by S. A. Goldsmith; Amberg & Co., by I. Gittleston; G. A. Webster & Co., by C. G. Coutts; Meriden Britannia Co., by W. C. Wood.

A useful card, issued by J. Schawel & Co., refiners, sweep smelters and assayers, 29 John St., New York, has been issued to the trade. It contains, in clear blue type, a table of sizes and weights of platinum wire, sheet and foil, which will prove an aid to many jewelers.

# Great Sacrifice Watch Sale.

A RARE OPPORTUNITY TO BUY FINE WATCHES

BELOW THE PRICE OF ORDINARY.

Having decided to discontinue the "Complete Watch" branch of our business and to hereafter confine our trade exclusively to watch movements, we offer our large and superb stock of Paillard Non-Magnetic Ladies' and Gentlemen's **Fine Gold Watches**, Plain and Complicated, at **prices less than manufacturing cost**. These watches are **high class** and carry with them our **full warrant and guarantee**.

This entire stock must be closed out, **regardless of cost**, before January 1st, to make room for **regular movements**. If you have a trade in **Fine Watches**, or appreciate **high class goods**, or if you have a customer to whom you can sell a Fine Watch, **this is the greatest opportunity ever offered** and

**ONE YOU SHOULD TAKE ADVANTAGE OF.**

Selection Packages sent to responsible dealers. Parties unknown to us will please furnish New York references. Descriptive "Sacrifice Sale" Circular mailed upon application.

A. C. SMITH WATCH CO., 177 Broadway, New York.

THE STAR OF EMPIRE WESTWARD TAKES ITS WAY

# WESTERN SUPPLEMENT

## of THE JEWELERS' CIRCULAR

Chicago Office: Room 517, Inter-Ocean Building.

VOL. XXIX.

CHICAGO, WEDNESDAY, NOV. 28, 1894.

No. 18.

### Chicago Notes.

#### TRADE CONDITIONS.

Business recovers slowly, though surely. The number of houses requiring night work of employes is increasing in number, but the trade at large is only fair. No special lines are deserving of distinction. The present week is looked to confidently for a changed business aspect.

Mr. Hickok, of the La Grande Hardware Co., La Grande, Ore., bought silverware here the past week.

Mr. Schauweker, of Schauweker & Chalmers, put in a week socially at Cleveland, the family home.

Mr. Gluck, proprietor of the Gluck Jewelry Co., Fort Dodge, Kan., and Mayor of that city, placed his Fall orders here the past week.

Mr. Todd, of Everson & Todd, Madison, Ind., is visiting in Florida. Mr. Everson, the senior partner, spent several days here buying.

A telegram states that the pawnshop of H. M. White, Decatur, Ill., was robbed of watches and jewelry valued at 1,500. The safe was broken open.

G. Musin, who some three months ago removed from 258 N. Clark St. to Louisville, Ky., has returned to this city and opened a store at 330 Milwaukee Ave.

Fred H. Allen returned Friday from a successful business visit to Davenport, Freeport, Rockford, Janesville, etc., in the interests of Simons, Bro. & Co.

The entire product of the No. 45 United States Waltham has been purchased by Schauweker & Chalmers, watch jobbers, Venetian building. This is an 18 size jeweled movement.

S. K. Huston has returned to his early love, the New Columbus Watch Co., and has temporary quarters on the sixth floor, Columbus building. Permanent quarters will shortly be established.

The following firms have been made honorary members of the Chicago Engravers' Association: Juergens & Andersen Co., G. W. Hook, Spies & Co., Robt. Beygeh &

Co., J. Milhenning, Theo. Schrader & Co., R. M. Johnson, Wendell & Co., and C. H. Bisson Co.

The well-known horological school which has heretofore been known as the Chicago Watchmakers' Institute in their advertisement announce their removal from Chicago to Rockford, where they have secured greater advantages and are in a position to give the best class of instruction at less cost.

W. C. Sommer, in charge of the optical department of Hyman, Berg & Co., who two weeks ago became entangled with a moving train which he attempted to board at 51st St., has recovered sufficiently to resume his duties. Mr. Sommer sustained severe injuries to his legs by being dragged by the train.

The original study of the Ada Rehan statue of Justice, cast in aluminum and resting on a brass base, was displayed the past week in one of Hyman, Berg & Co.'s windows and attracted much attention. A coronet of diamonds and scales bearing jewelry enhanced its natural beauty. Good taste is shown by E. P. Albright in his window decorations for the firm.

U. E. Penney has purchased the interest of L. E. Winslow in the Winslow & Penney Co., 608 Masonic Temple, and will continue the business. The company have a complete plant for wheel cutting and demagnetizing and make a specialty of watch repairing for the trade. The plant is finely equipped for turning out special gears and models of every class.

"Largest November business we ever had," reports the Towle Mfg. Co., 149-151 State St. "We have shipped more goods than in any previous November in the history of the house." In this record their handsome new pattern, "The Empire," has held a commanding place, with sales of "Old English" unusually large. The Empire is in serviceable weights, and cannot fail to please a customer at sight.

M. S. Fleishman, formerly of 176-178 Market St., has completed his removal to the Masonic Temple. The firm has quarters on the second floor directly over the Main St. entrance. The room is 30

feet in height, extending to the floor of the fourth floor, with a bronze gallery on three sides on a level with the third floor of the building. The glass front takes in the entire arch of the main entrance to the building, giving exceptionally good light. The gallery is used for shipping and stock purposes, and the main floor admits of unique arrangement.

Firms represented last week by buyers in Chicago included: Mr. Gluck, Gluck Jewelry Co., Fort Dodge, Kan.; Mr. Everson, Everson & Todd, Madison, Indiana; W. J. Keating, Watertown, S. D.; Carl Oesterle, Joliet, Ill.; C. N. Frazier, Norwalk, Ohio; N. H. Knowles, Humboldt, Iowa; Mr. Hickok, La Grande, Ore.; C. H. Haney, of Haney & Pierce; S. Thompson, Remington, Ind.; W. A. Bowen, Kewanee, Ill.; G. F. Schermund, Greenville, Ohio; H. H. Bisbee, Ludington, Mich.; H. B. Clark, Rantoul, Ill.; W. W. Denny, Aurora, Ill.; J. W. Spence, Racine, Wis.; W. A. Kirkham, Leavenworth, Kan.; Mr. Utley, of Utley & McLaughlin, Bancroft, Ia.; J. G. Bodenschatz, Lemont, Ill.; D. S. Bowen, Richland Center, Wis.; Albert Miller, Dundee, Ill.; M. C. Knudson, Kenosha Wis.; L. Buysse, South Bend, Ind.; J. F. Ingalls & Son, Waukegan, Ill.; L. H. Bauer, Elgin, Ill.; J. E. Carlson, Arthur, Ill.; A. Hooper, Lodi, Kan.; Julius Taussig, Hammond, Ind.; R. Taussig, Chicago Heights, Ill.; H. A. Oesterreich, Watertown, Wis.; C. J. Peterson, St. Charles, Ill.; Secord-Hopkins Co., Kensington, Ill.; P. Pfeiffer, Lemont, Ill.; Reinhart & Mittendorf, Lincoln, Ill.; J. R. Schneider, Evanston, Ill.; Jno. Spencer and daughter, Edgerton, Wis.; Racine Jewelry Mfg. Co. Racine, Wis.

The Yale football team which played Harvard, Saturday, Nov. 24, anxiously hoped for the return of Walter Camp, secretary and treasurer of the New Haven Clock Co., from California, but inquiry of the company elicited the information that a letter just received in New Haven stated that he was still in California, coaching the Leland Stanford university football eleven, and would not leave there till Dec. 1.

# LOOK AT THESE PRICES!

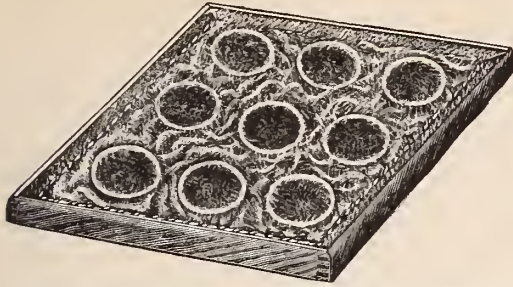

Show Case Trays with Solid Walnut Frames lined with Fine Red Silk Plush, with Old Gold Border, and made to stack one on top of the other. Size, 11 3/4 x 11 3/4.

- For Gents' Watches, each, . . . . . \$1.25
- For Ladies' Watches, each, . . . . . \$1.25
- For Rings, each . \$1.25. For Chains, each, . \$1.25
- For Charms, ea., \$1.25, for Card Jewelry, plain, ea., 80c.

Subject to the usual discount for cash.

**CHRISTMAS IS COMING.**  
 Make your Stock Attractive and Fresh.  
 It does not cost much and will add largely to your SALES.

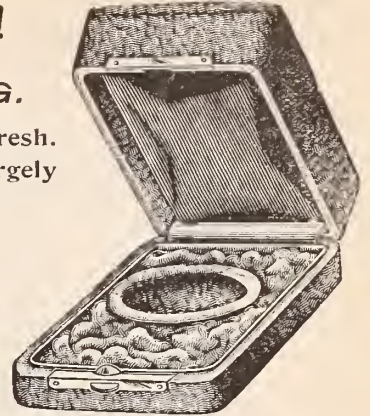

FINE PLUSH BOXES.

## BENJ. ALLEN & Co.,

141 & 143 State St.,  
 CHICAGO, ILL.

WATCHES, CLOCKS,  
 DIAMONDS,  
 SILVERWARE  
 and JEWELRY.

- For Gents' Watches, per dozen, \$3.00
- For Rings, per dozen, \$2.00
- For Six Tea Spoons, per dozen, \$9.00
- For Child's Set, per dozen, \$9.00
- For Sugar Shell, per dozen, \$9.00
- For Ladies' Watches, per dozen, \$2.00
- For Ear Drops, per dozen, \$2.50
- For Six Table Spoons, per dozen, \$15.00
- For Six Coffee Spoons, per doz., \$15.00
- For Butter Knife, per dozen, \$9.00

Subject to the usual discount for cash.

### PARSONS : SCHOOL —FOR— WATCHMAKERS, PEORIA, ILL.

Send for Circular and Terms.

PARSONS & CO.

THE PLANCHAMP & BECKER CO.  
 Makers and Repairers of  
**WATCH CASES,**  
 Gold and Silver Plating —  
 — of Watch Cases a Specialty.  
 UNEXCELLED FACILITIES.

63 and 65 East Washington St., Chicago.

### G.A. WEBSTER

42 & 44 Madison St., Chicago, Ill.  
**Manufacturer,**  
 AND WESTERN AGENT FOR  
 E. G. WEBSTER & SON, of Brooklyn, N. Y.  
 A. F. TOWLE & SON CO. of Greenfield, Mass.

No jeweler or watch repairer should be without a copy of "WORKSHOP NOTES," a new and very useful book for the workshop. Send for circular containing a complete index of the book, and judge of its merits for yourself.

### GENEVA OPTICAL Co., CHICAGO.

CATALOGUES.

- PART 1—General Catalogue of Optical Goods.
- " 2—Microscopes and Accessories.
- " 3—Photographic Cameras, Stocks and Supplies.
- " 4—Thermometers, Barometers and Meteorological Instruments.

**PRESCRIPTION WORK** Made with Promptness and Accuracy.  
**OCULISTS' or OPTICIANS' OUTFITS.** Trial Cases. Ophthalmoscopes. Lens Measures.  
 CORRESPONDENCE SOLICITED.

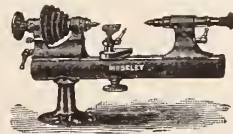

One of the best of the very best.

QUALITY IS THE STANDARD OF VALUE  
 FOR WHICH WE COMPETE  
 "THE MOSELEY."

"A Bread Winner" for the watchmaker  
 We furnish you good lathes and chucks,  
 while the other fellow furnishes the wind.

MOSELEY & CO., Elgin, Ill.



No. 2 Moseley Wire Chuck has length, strength, accuracy.

MORE ADVANTAGES—LESS COST.

## CHICAGO ROCKFORD Watchmakers' Institute

211-20 WALNUT ST., ROCKFORD, ILL.

Write for New Terms : G. D. PARSONS, Principal

### 17 Jewel Dueber-Hampden Watches

ARE THE MOST RELIABLE WATCHES MADE.

A FULL LINE OF DUEBER CASES AND HAMPDEN MOVEMENT.

Write for New Price List.

**Brethauer Watch and Jewelry Co.,** Special Agents,  
 71 WASHINGTON ST., CHICAGO, ILLS.

## A GOOD SELLER!



SOMETHING NEW, BADLY WANTED.  
 Popular Prices. Highest Grade Finish.  
 Best Quadruple Plate on Solid White Metal.

### Individual BUTTER and SOUVENIR PLATES.

Any Name or Initial Engraved to order.  
 Put up in Single Pieces or in Sets, as desired.  
 Order Samples.  
 Send for Illustrated Circular of Quick Sellers.  
**EXCLUSIVE CONTROL GIVEN TO LIVE JEWELERS ON GOOD ORDERS.**

- 1 Set (1/2 doz.), Plain Polish or Satin Center, Round or Square, in Enamelled Case, complete . . . \$2.25
  - 1 Set (1/2 doz.), in Fancy Design or Initial Engraved Center, Square or Round, in Case. . \$2.88
- Plush Cases for the above, 75c. each extra.  
 All prices subject to 6 per cent. off for cash with order.  
 These are also finished in Gold Borders.

A nice idea is a Plate with single name engraved to give to individuals.  
 They are Sure Trade Winners. ORDER QUICK.

## O. E. BELL & CO., Mfgs., Cincinnati, O.

The St. Louis Ophthalmic College and Hospital

[A SCHOOL OF THEORETICAL AND APPLIED OPHTHALMIC OPTICS.]

1655 SOUTH JEFFERSON AVENUE,

N. W. Corner Lafayette Avenue, ST. LOUIS, MO.

For the Announcement and further information, address Ignatz Mayer, M. D., President.





A concern standing on a platform which embraces **HIGH CHARACTER OF ITS PRODUCTIONS, TRUTHFULNESS OF ITS ASSERTIONS, RELIABILITY OF ITS SERVICE, POSITIVE CERTAINTY OF ITS RIGHT PRICES,** a concern embodying **BRAINS, EXPERIENCE, CAPITAL and ORGAN-**

**IZATION** must succeed, and its productions constantly grow in favor.



**THE EMINENT POSITION** we now hold in the **PLATED-WARE WORLD** has been gained only by intelligent and unremitting work, and by a strict adherence to those principles without which there can be no success.

Having a clear knowledge on all points of manufacturing, a plant equipped with every facility, manufacturing every article on an extensive scale, we have proven and will continue to prove the possibilities of selling **HIGH CLASS PLATED WARE** at comparatively **SMALL COST**, and we are confident the trade will continue to reward us with that appreciation which insures success.

Thus, by the employment of every known mercantile force our position has been changed from the commonplace to the extraordinary,



AND THIS TRADE

MARK

known throughout the length and breadth of the land, is recognized as the **MARK OF MERIT** and **RELIABILITY**.

It is, therefore, but the natural result of our success in the past, that we look forward with particularly bright expectations to the future.

As a means of still further promoting trade relations, we have deemed it essential to have **PERMANENT REPRESENTATION IN NEW YORK CITY**, and we take pleasure in informing our friends, and the trade in general that in January next we shall establish an agency there, at

**Nos. 304 & 306 Fourth Ave., cor. Madison Square.**

This agency will be under the direction of **MR. ROBERT LEFFERTS**, whose high character and solid reputation are widely known; his associate, **MR. ROBERT W. WHITE, Jr.**, scarcely needs an introduction—his familiarity with plated ware, and ability as a salesman, being well known by all the trade. It is further purposed to associate with our agency capable representatives to look after the trade in New York City, Brooklyn and adjacent cities, and likewise to bring our line to the attention of all **BUYERS IN THE EASTERN SECTION**, and **VISITING BUYERS** from any part of the country. We feel convinced that this step will enable us to cater better than ever to the requirements of our patrons and the trade at large and will tend to promote our common interests.



**HOMAN & COMPANY,**

**CINCINNATI.**



### Pacific Coast Notes.

H. Hauschildt, Hayward, Cal., is making extensive improvements in his store.

F. W. Parker, Ukiah, Cal., has been in San Francisco buying his holiday goods. A. Thuman, Healdsburg, Cal., was in that city on a similar errand.

John Cedarstrom, jeweler, of Portland, Ore., was arrested a few days ago charged with the larceny of some jewelry left in his care to repair. He was arrested at Sycamore, and states he had no intention of keeping the property.

The new store of M. Lissner & Co. has been opened in Oakland. The Standard Optical Co. state that they are in no wise interested in this new establishment and that if they open a branch in Oakland it will not be in connection with any jewelry house.

### San Francisco.

E. H. Adams, of New York, was a guest at the Lick a few days ago.

The Chicago Clock Co., 1622 Market St., have reopened with a new stock.

A. L. Hammersmith has been absent from his business on account of an attack of rheumatism.

G. G. Brooks, Colusa, and C. H. Tully, Middletown, have been here from the country on business.

R. Bostleman, of Bostleman & Braverman, has arrived from New York with his family, and will establish himself here permanently.

J. L. Lombard, 622 Kearney St., made an assignment a few days ago. No statement has yet been made. The liabilities amount to about \$5,000. Chicago and New York houses are the main losers. There is a large stock, but it is mainly of an unstable character.

Shreve & Co. have increased their force by J. Beatty, formerly with Manning & Co.; F. S. Wilson, formerly with Phelps & Miller R. Glockey, late of Bostleman & Braverman. Sylvan Winkheim, formerly with Max G. Franklin & Co., is now with Emile Hirshfeld & Co., a new jobbing house who have started in rooms 59-60 Crocker building.

### Rockford.

E. L. Carpenter has opened a jewelry business at 426 E. State St.

The Rockford Silver Plate Co. are now running nights to fill orders.

John T. Buker, jeweler, carried off the honors at the annual shoot of the Oregon Gun Club.

The Secretary of State has issued a charter to the Rogers Silver Plate Co. to do business in this city. The incorporators are three men of the Rockford Silver Plate Co. The company are now making so-called "Rogers" silver plate.

The Rockford Silver Plate Co. have turned out a piece of work which has at-

tracted much attention and won much praise for the makers. It is a set of resolutions engraved on a silver sheet and enclosed in an envelope of silver with a gold lining. On the front of the envelope besides the regular address and stamp is engraved a G. A. R. badge, while on the back is a camp kettle and fire. The envelope is fastened with the regulation Grand Army button. It is to be presented by Commander-in-Chief T. G. Lawler, of this city, to Past Commander-in-Chief Robert B. Beath, of Philadelphia, on his coming eastern trip.

### Kansas City.

F. O. Hadley, for 10 years located at 1010 Main St., has sold out.

H. Freund, of Max Freund & Co., New York, was in town the 21st inst. E. A. Reed, of Reed & Barton, was also here last week.

W. D. Elcox, of Larter, Elcox & Co., who has not been on the road since last March, has again started out and will be here about Dec. 12th.

W. L. Nason, of R. Wallace & Sons Mfg. Co., Chicago, was well pleased with the numerous orders he secured while in town last week.

The C. E. Russell Jewelry Co., of this city, have the contract for five thousand buttons for the Mid-Continent Poultry Show, which meets here this week. These buttons are being made by the Meyer Jewelry Co.

The store of A. Goldman, St. Joseph, Mo., was, I learn, robbed of over \$600 worth of watches and jewelry by a gang of tramps, who have been committing depredations for some time with unusual boldness. They gained an entrance by forcing the rear door.

Woodstock, Barger & Hoefler, wholesale jewelers, report the following of their country customers in town last week: I. L. Grady, Slater, Mo.; A. Gluck, Dodge City, Kan.; W. W. Whitsit, Liberty, Mo.; O. Kolttsbad, Liberty, Mo.; and A. B. Regvein, Henington, Kan.

An important event of the Fall season in Kansas City was the holiday opening of the Jaccard Watch & Jewelry Co., on Nov. 21. Their beautiful store on Main St. is especially adapted for the display of fine goods, and from the immense crowds which filled their aisles during the day and evening, the firm can rest assured that they scored a decided success. All the windows were covered with black cloth and the new incandescent lights studded in the ceiling threw a most agreeable light. Good music was furnished and the whole store was decorated with palms. A small souvenir, "My Christmas List," which contains suggestions for Xmas shopping, was given to every visitor. This firm occupy the whole of the building where they are located, the second and third floors being occupied by the watchmakers and the stationery shop.



Our Salesman

# Watch

the results of

# Our Salesman

640 Page Catalogue, 1895,

# Open

On your Show Case.

That will prove his value to you. He does not draw any salary but will double your sales. Open on your show case, as inquisitive people can't help but buy. Bottom prices and special drives are his strongest arguments why you should buy of him.

Send for our 640 Page Illustrated Catalogue if you haven't received it. It's a money maker for you.

OUR NAME DON'T APPEAR IN IT.

## F. M. Sproehne & Co.

103 STATE ST., CHICAGO,

Wholesale Jewelers.

YOU'LL SAVE MONEY

by ordering your Holiday Stock from it.

C. C. Hoefler, of Woodstock, Barger & Hoefler, has just returned from a trip through Texas. He reports a very favorable outlook in the jewelry trade in that locality.

The Baird building, having been entirely condemned since the recent fire, Ben Levin has moved to 114 W. 6th St. Mr. Levin did not lose very heavily, his principal loss being from water.

The Jaccard Watch & Jewelry Co. have just finished alterations on their store. Stained glass has been placed in the upper part of the windows and also in the ceiling. It is of a color that will counteract the light reflected from the buildings across the street. They have also had numerous incandescent lights imbedded in the ceiling which thro' a much smoother light than the hanging electroliers did before.

### Detroit.

I. O. Chapman has moved his stock of jewelry from Stanton, Mich., to Lake View, Mich.

John Johnson, Manistee, Mich., left his home last week and has not been heard from since.

Beach & Co., of this city, have dissolved partnership. Morgan Beach will continue the business as heretofore.

Beard Bros. have purchased the jewelry stock of A. B. Clark, Morrice, Mich., and will continue the business.

The following Michigan country jewelers visited Detroit jobbers last week: Mrs. E. A. Cress, Minden City; F. T. Barbour, Oxford; and C. E. Montford, Utica.

Burglars last week entered the store of Alfred Milnes, at Coldwater, and stole \$50

from the money drawer and 12 watches. Mr. Milnes was elected Lieutenant-Governor at the recent election.

The United States Optical Co. were recently robbed of several hundred dollars' worth of gold eyeglasses. The thieves have successfully escaped detection, but a clue may rest in the fact that during the past two or three weeks several agents have struck different places in the State selling glasses that they allege were found. One stopped at Port Huron and another at Imlay City.

An eastern novelty in hotel supper table decoration was introduced at the Hotel Cadillac last week. It consisted of a silver candelabrum with two lighted candles in the middle of each of the 36 tables. Over each candle a small red shade was placed. But half the electric lights ordinarily used were turned on, leaving the large dining-room in half darkness. Every table, with its own light shaded, in this way seemed isolated from the others. The candelabra were received from E. G. Webster & Son.

Gus Huber a prominent young society man and jeweler, in Fayette, O., just over the Michigan line, was arrested at Montpelier, O., last week on the charge of complicity in the robbery of the Alvornton express office, several weeks ago. It will be remembered that several Chicago jobbers received orders for goods to be sent to Alvornton, to fictitious addresses. The express office was then robbed. A large portion of the jewelry it is alleged, was found in Huber's store. A letter which he dropped in the express office on the night of the burglary was the clue which led to his detection.

### Louisville.

Mrs. Henry Lubbie, daughter of Mr. Geo. Wolf, died at her home in Quincy, Ill.

A. J. Esterly, Bloomfield, Ky., passed through here sick on his way home from Cincinnati, O.

Wm. Kendrick's Sons are making extensive improvements in their window, which will give them much larger space.

Wm. C. Kendrick has just returned from the banquet of the New York Jewelers' Association. This was Mr. Kendrick's second trip east this Fall.

The jewelers of Louisville petitioned Buschemeyer & Seng, the diamond setters, to work exclusively for the jewelry trade and not take work from anybody who was not a jeweler. Buschemeyer & Seng agreed to the proposition and have had cards struck to the effect that from this time forward they will work exclusively for the jewelers.

### Indianapolis.

Horace A. Comstock left last week on an extended hunting trip.

W. J. Rowe & Co. have opened a large and handsome new jewelry and bric-à-brac store in Marion, Ind.

Ross J. Haseltine, Kokomo, Ind., and L. J. Savage, Macy, Ind., were among the buyers here last week.

W. H. Bradbury, formerly of this city but recently from Cleveland, O., has returned and taken a position with Horace A. Comstock.

Enrique C. Miller, of Baldwin, Miller & Co., contemplates an extended visit to Mexico, the home of his parents, after the holidays.

# DIAMONDS

Loose and Mounted, in Endless Variety, at Unequalled Prices.

61 West Fifth St., A. G. SCHWAB & BRO., Cincinnati, Ohio.



Sole Agents for the Celebrated **PASHA DIAMOND...**

White Stone Gold Jewelry.



L. BLESCH, Secretary.

C. A. REMME, Manager.

H. DUNWOODIE, Treasurer.

**THE QUEEN CITY WATCH CASE MANUFACTURING COMPANY,**  
Manufacturers of Fine Gold and Silver WATCH CASES,  
19 & 21 WEST FOURTH STREET (Keck Building), CINCINNATI, OHIO.

Special Attention given to Repairing.

Estimates Cheerfully Given

## D. SCHRODER & CO.,

## WHOLESALE JEWELERS AND IMPORTERS,

Diamonds, Loose and Mounted at Big Bargain Prices. Sole Agents for West and South of  
Howard Watches at Greatly Reduced Prices. Send for our Catalogue, it will please you.

252 RACE STREET, CINCINNATI, O.

The *News'* subscription for Indiana's gift to the battleship *Indiana* has reached \$1,150. \$8,000 is the sum desired with which a handsome solid silver service is to be purchased.

At a meeting held Nov. 16th the members of the Retail Jewelers' Association expressed great satisfaction at the manner in which the American Waltham Watch Co. had gone to work to ascertain what eastern jobber had sold their goods to a local dry goods firm. The Waltham Co. acted with encouraging promptness and promised to locate the wrong and then to "apply the remedy."

Among the traveling men seen in Indianapolis, Ind., last week were: Ernest Block, W. & S. Blackinton; C. A. Fraser, Hancock, Becker & Co.; Jno. Nathan, Rothschild Bros.; J. N. Beckwith, Jos. H. Fink & Co.; Chas. W. Hempel, Sandland, Capron & Co.; Chas. J. Pease, Vincennes Novelty Mfg. Co.

**Successful Ball of the Jewelers' Council.**

CHICAGO, Ill., Nov. 24.—The first ball of Jewelers' Council, No. 316, National Union, was held at their hall, 210, 211 Masonic Temple, the evening of Nov. 17th. The occasion met in every way the anticipations of the promoters and was voted by all to be a brilliant success. President W. J. Meyer was highly complimented for his skill in arranging the details. Dancing began at 9 p. m., and continued till midnight, the following members and their friends participating.

Messrs. and Mesdames: C. E. Hodge, H. M. Bullwinkle, S. Levey, F. H. Booth, Harry Sax, Fred. McGreedy, Jameson, Smith, Melmes, Bennett, Sherwood.

Misses: Levinson, Kreitling, Wilson, Virtue, Wenke, Farquharson, Hanock, McDonald, Ebersole, Harrison.

Messrs.: W. J. Meyer, A. M. Johnson, C. A. Barnes, Otto Stumpf, H. S. Winters, H. E. Farquharson, R. McNulta, B. A. Bigelow, Walter Kreitling, T. Kidd, J. Bachner, J. T. Campbell, S. D. Gould, B. Volk, C. G. Tollefson, J. C. Heinold, Carl Hirt, George Yott, F. A. Legros, Dr. Geo. N. West.

J. T. Cotney and L. C. Bell have severed their connection with the Americus Jewelry & Music Co., Americus, Ga., of which they were respectively manager and secretary and treasurer.

Jensen's jewelry store, Beresford, Ia., was burned out with others Nov. 20th.

G. B. Widdifield, Columbia City, Ind., is arranging a neat little room back of his jewelry store which he will use as an office and optical room.

Wuersten Bros.' jewelry store, Columbia City, Ind., has been repainted and the walls have been cleaned and everything looks as bright as a new dollar.

**Cincinnati.**

The Queen City Watch Case Co. have had a very successful season, and are now filling orders from numerous out-of-town customers.

Albert Bros. are in the market with a beautiful line of silver novelties. Their trade called for them and they were obliged to handle them.

Chas. Stern is still at the hospital under the watchful care of the best physicians. He will possibly have to undergo a surgical operation this week.

Gustave Fox & Co. have turned out some exceedingly artistic diamond work the past week. Lee Kaufman will make another trip before the holidays.

D. Schroder & Co. are continually receiving new goods to fill their numerous orders. Their travelers keep up a brisk correspondence and the house has to hustle to fill orders promptly.

Peter Henry, the well known watch case repairer, is still at the old stand. Business is picking up and all the wheels in the factory are turning. The force are now engaged on a lot of special cases.

Fred Steinman, western traveler for F. W. Gesswein, New York, is laid up at the hospital with pneumonia. Harry Walton, of the Wadsworth Watch Co., has been very attentive to his comforts. He is reported somewhat better.

John Francis and Mr. Solar, of E. & J. Swigart, are on the road doing good business. The business of this firm has been enormous the past few months. Their entire building is one of rush and hustle. John Swigart is now in command. Eugene is now on the road.

A. G. Schwab & Bro. are pushing diamond goods this season, and have made many handsome sales. They have bought largely and are giving their customers great bargains. Their white stone goods called the "Pasha diamond," is becoming a great trade favorite.

O. E. Bell & Co., manufacturers and jobbers, are out with a decidedly new line of silver novelties. They turn out individual butters and trinket trays with any name engraved on them. Their latest offer is a set in a neat paper box at such figures that every one should have them.

**Buffalo.**

F. P. Jolls, Attica, was robbed, last week, of about \$500 worth of watches and \$200 worth of rings. The burglars drilled his safe and blew it open. Mr. Jolls came to Buffalo to notify the police, and has the numbers of all the movements and cases.

The out-of-town buyers here last week were: E. L. Birchard, Cambridgeboro, Pa.; F. E. Burton, Niagara Falls, N. Y.; R. C. Holmes, Gowanda, N. Y.; F. D. Kelsey, East Aurora, N. Y.; D. Elsheimer, Niagara Falls, N. Y.; Mr. McCoy, of Mundie & McCoy, Tonawanda, N. Y.; Geo. Engle, Springville, N. Y.; J. Schwor, Avon, N. Y. J. England, Niagara Falls, Ont.; W. A. Quinlan, Pavillion, N. Y.; J. C. Malone, Mt. Jewett, Pa.; J. Kearney, Medina, N. Y.; C. R. Dunkin, Middleport, N. Y.

**The Chicago Engravers' Association Adopt a Constitution.**

CHICAGO, Ill., Nov. 24.—At the special meeting of the Chicago Engravers' Association, held on the 19th, the constitution and by-laws were adopted and a committee consisting of L. Hadorn, D. G. Boone and Richard O. Kandler appointed to make application to the Secretary of State of Illinois for articles of incorporation as an association.

The principal object of association as stated in the constitution is "checking the downward tendency of prices," and the adoption of a price list for engravers that shall be fair and reasonable for good and careful work. Annual meetings will be held the fourth Wednesday evening of October, each year, and provision for special meetings also made. No proposition has been decided on for monthly meetings as yet.

Mr. Furber informed the committee that he was fitting up a room on the 6th floor of the Columbus building for meeting purposes, and this will probably be the headquarters for the monthly meetings. An invitation has been extended to journeymen engravers who are eligible to associate membership to meet with the association members next Monday. Mr. W. H. White, secretary of the association will gladly give any information desired.

EST. 1870.



DR. PETER HENRY  
SPECIALIST IN

Watch Case Diseases

Key Winders changed to Stem Winders

Hunting Case changed to O.s

English Case changed to fit American movements.

Can be cured at

53

LONGWORTH ST.,  
Cincinnati, Ohio.

**GUSTAVE FOX & CO.,** IMPORTERS OF  
**DIAMONDS.**  
Makers of Artistic Diamond Settings & Setters.

Our patented Elk Jewelry which we make in solid gold and rolled plated, has become the favorite throughout the country. Should you need anything in this line, send for catalogue and price list.  
**GUSTAVE FOX & Co,**  
148 W. 4TH STREET, CINCINNATI, OHIO.



Pat. May 27, '90.  
The Antlers forming the letters B, P, O, E.

**Three New Affidavits of Attachments in the Simon Rumpf Case.**

SEATTLE, Wash., Nov. 20.—The Simon Rumpf case was revived last week by the filing of three new suits in the Superior Court in the shape of affidavits of attachments against Simon Rumpf and Joseph Mayer, by the Towle Mfg. Co. to recover \$419.10; Unger Bros., to recover \$1,062.60; and a complaint filed by W. & S. Blackinton to recover \$1,047 for goods furnished.

The complaint of W. & S. Blackinton sets forth that early in 1894 an agreement was entered into between Rumpf & Mayer by which Rumpf's name only should be used in the transaction of business, and that Mayer's interest should be kept secret, but he have half interest in the business; that some time subsequent thereto they conspired and conceived the scheme of defrauding and cheating all persons or corporations from whom they should purchase or receive consigned memorandum goods; that in pursuance of this scheme they removed large consignments of jewelry, disposed of same and converted the money to their own use; that the plaintiffs, in ignorance of this scheme, shipped Rumpf a lot of jewelry last August amounting to \$1,047, for which they never received a dollar; that Rumpf fled the city on the night of Aug. 28th with the knowledge and assistance of his co-conspirator, secret co-partner and co-defendant, Joseph Mayer, and that Rumpf, prior to his leaving, conveyed to Mayer a deed of conveyance dated Aug. 28, 1894, of certain real estate in this State; that in pursuance of this conspiracy, the defendants sold, and by bill of sale dated and executed by Rumpf on Aug. 28th conveyed to J. K. Basye and Jennie H. Kline all the stock of

jewelry, fixtures and furniture at 620 2d St., for which Basye paid \$5,000 to Rumpf, who paid it over to Mayer, and he, Mayer, appropriated the same to his sole use and without paying anything whatever and for the purpose of carrying out the conspiracy.

**Grant Srack Succumbs and Makes an Assignment.**

FREMONT, Neb., Nov. 21.—Grant Srack, a jeweler of this city, has succumbed and made an assignment for the benefit of his creditors. Eleven chattel mortgages were filed, aggregating \$3,209.46, as follows: Hickory Wheel Co., \$96; C. Straus & Co, \$47.75; Shapleigh Hardware Co., \$320; Wm. L. Gilbert Clock Co., \$40.25; Commercial National bank, \$492.50; C. Christensen, \$538.12; F. P. Smith, \$386.43; L. E. Meyer, \$360; Dayton & Co., \$262.63, Western Jewelry Co., \$422.43; B. F. Norris, Alister & Co., \$243.30. The total indebtedness is about \$4,200, with assets, including book accounts, of about \$3,000.

**New Opal Field Reported Discovered in Mexico.**

SANTE FE., N. M., Nov. 22.—Samples of opal in the rough brought in from a newly discovered ledge in Cochita, wherein several claims have been located, have been cut by jewelers here, and are said to be of a splendid quality, of both fire and royal opals. These specimens were taken only 10 feet from the surface. Several miners are preparing to develop the claim.

Cornelius Van Den-Elsen's jewelry store Green Bay, Wis., was burglarized last Monday night, and \$500 worth of goods stolen. There is no clue to the thieves.

**Secretary of F. G. Smith, Sons & Co. Held in Bail.**

DETROIT, Mich., Nov. 23.—Recently Judge Carpenter ordered Charles Roe, Jr., secretary of the old corporation of F. G. Smith, Sons & Co., to be held in bail in the sum of \$7,000, on complaint of F. G. Smith. It was asserted that while Mr. Smith was at home sick and his sons temporarily absent, Roe took from the store watches, jewelry and diamonds valued at \$5,625, and left a memorandum that the goods should be charged to him. Mr. Smith now claims that Roe has not paid for the goods and has refused to return them. Mr. Smith maintains that he had no authority to sell them to himself. Merrill B. Mills and Benjamin F. Haxton last week went on Mr. Roe's bail bond.

When the old firm of F. G. Smith, Sons & Co. got into financial difficulties, a full account of which was published in THE CIRCULAR, Mr. Roe was a member. He foresaw the result of the trouble and seized the goods in question to protect himself. Litigation will follow to determine the terms of settlement between him and the new concern.

**Jos. Wolf Executes a Deed of Trust.**

DALLAS, Tex., Nov. 23.—Jos. Wolf, dealing in jewelry, etc., and doing business at 268½ Main St., has filed in the county clerk's office a deed of trust to secure preferred creditors. The instrument names Leo Wollstein as trustee, and conveys to him the entire stock of goods, wares and merchandise, to secure the following creditors:

Class A.—City National Bank of Dallas, \$700; McCormick & Spence, \$150; B. Dienstag, \$400; J. Wilkinson, \$195. Total, \$1,445.

Class B.—H. Eels, of Dallas, \$62.50; R. Cohn, \$65; M. Benedikt & Co., \$75; I. Reinhardt & Son, \$75; N. Goettinger, \$250; M. Weichsel, of Denison, \$350; I. Israel-sky, \$400; W. S. Shuttles & Son, \$100; H. Gretzner, of New Orleans, \$1,600. Total, \$2,977. Total, both classes, \$4,420.

So much of the demands in class A as have not been paid shall be paid in full, and if a sufficient sum has not been realized to pay in full all the claims of class B, whatever sum is applicable shall be pro-rated equally among said demands.

Bernard R. Heming died at his home, 733 Hampshire St., Quincy, Ill., some days ago, aged nearly 60 years. He had been a sufferer from cancer some time. Deceased had lived in Quincy about 35 years. He was born in Germany and was a jeweler and watchmaker.

The first individual communion service introduced in Michigan was used Nov. 18 in the wealthy Westminster Presbyterian Church, of West Bay City. The cups are diminutive, silver plated and gold lined. The popularity of individual cups for church use is becoming evident and is largely based on sanitary reasons.

**E. & J. SWIGART, JOBBERS OF TOOLS & MATERIALS.**

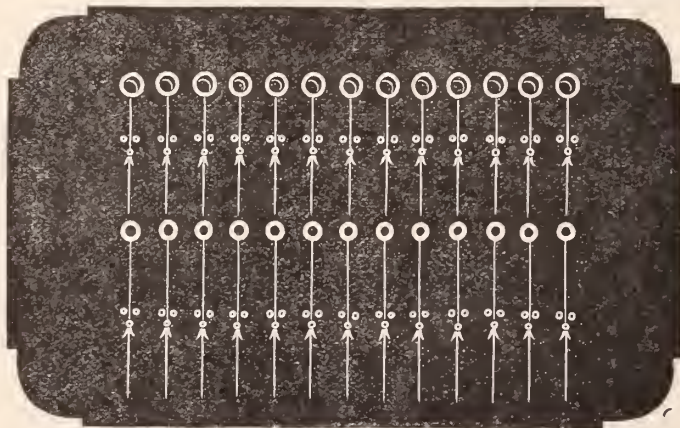

**14 K. Gold Watch Hands. QUALITY WARRANTED.**

The following Sizes in Stock.

18 Size, Waltham, S. W. - Price per doz, pair, \$7.50	18 Size, Elgin, S. W. Price per doz, pair, \$6.00
16 " " " Htg. " " " 7.50	16 " " " " " " " 7.50
16 " " " P. S. " " " 7.50	16 " " " Int. " " " 7.50
6 " " " " " " " 7.50	6 " " " S. W. " " " 6.00
0 " " " " " " " 6.00	0 " " " " " " " 6.00

14 K. Seconds to match, - Price per doz., \$2.50

Send us your Material Orders, if you want good attention and prompt service.

**101 WEST 5TH ST., CINCINNATI, O.**



# TORTOISE SHELL

## HAIR PINS AND COMBS, WITH STERLING SILVER ORNAMENTS.



No. 1. HAIR PIN,  
\$1.25 Each.



No. 2. HAIR PIN. \$1.50 each.



No. 4. SIDE COMBS. \$7.50 per Dozen Pair.  
VERY NOBBY.



No. 3. HAIR PIN. \$1.50 Each.

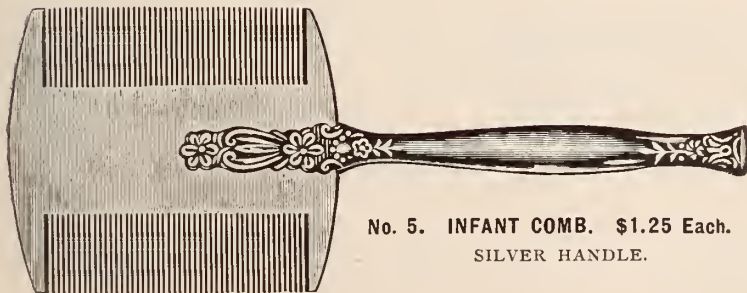

No. 5. INFANT COMB. \$1.25 Each.  
SILVER HANDLE.

All Prices are subject to 6 per cent. for cash.

**EVERY UP-TO-DATE JEWELER**

Should have an assortment of above Goods.

**BUY THEM "NOW."**

# GLICKAUF & NEWHOUSE, 84 and 86 State St., Chicago, Ill.



**FRED. I. MARCY & Co.**

MANUFACTURERS OF

**JEWELRY,**

PROVIDENCE,

59 PACE STREET.      RHODE ISLAND, U. S. A.

# THE BOWDEN SEAMLESS RING

IS MADE ONLY BY

## J. B. BOWDEN & Co.,

Makers of Finger Rings of every Description.

REMOVED FROM BROADWAY AND JOHN STREET,

**TO 3 MAIDEN LANE,**  
NEW YORK.



## Now that we have touched bottom



And business generally is improving every GOOD RETAIL JEWELER should make his stock attractive and so invite customers. He can buy nothing more sure of sale than



of standard quality, at moderate cost, and of new and taking styles. If not called upon by our travelers send your orders direct to

**M. B. BRYANT & CO.,**  
10 MAIDEN LANE, NEW YORK.

### The Latest Patents.

ISSUE OF NOV. 20, 1894.

**529,360. WATCH-PROTECTOR SWIVEL.** WILLIAM T. BRAHAM, Manchester, England. Filed Apr. 16, 1894. Serial No. 507,728. (No model.) Patented in England, Oct. 6, 1893, No. 18,730

A watch swivel comprising the body *a* provided with a joint *b*, hooks *c* oppositely pivoted to the body at

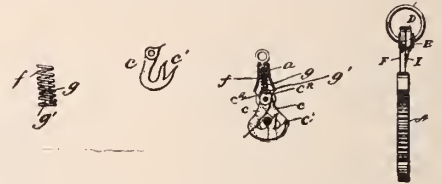

said joint and provided with adjacent oppositely inclined surfaces and prongs *c'*, and a spring *f* engaging said hooks to hold them in normal position, combined and arranged substantially as described, so that when the body is pulled upon in a direction away from the hooks the resistance of the watch bow or ring upon the adjacent oppositely inclined surfaces of such hooks will cause said hooks to move across one another and more securely bind themselves about the bow and thereby project their prongs outwardly to engage the pocket or other adjacent receptacle containing the watch.

**529,577. COMBINED KEY - RING AND CIGAR - CUTTER.** EDWARD B. AIGUIER, Newark, N. J., assignor of one-half to the Richardson Manufacturing Company, same place. Filed Aug. 21, 1894. Serial No. 520,890. (No model.)

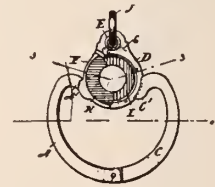

A combined ring and cigar cutter, comprising a ring having its ends spaced apart and formed of two hinged sections, and a cutter formed of a fixed and a movable section, said cutter being secured to one end of the ring and having its movable section engaging the other end of the ring and adapted to be operated thereby.

**529,611. METHOD OF SETTING DIAMONDS IN CUTTING-TOOLS.** ALBERT DITTMER, Berlin, Germany.—Filed Aug. 15, 1893. Serial No. 483,165. (No model.)



The method of setting diamonds consisting in placing the diamond in a hole or socket in the tool, placing over the diamond when seated a piece of material to hold it in position, said material being capable of being crushed or forced out of the opening when the metal is forced about the diamond and finally heating the material and hammering it about the diamond to hold the same and at the same time crush out the holding material.

**529,670. PROCESS OF ENAMELING.** WILLIAM C. STEWART, Bellaire, Ohio.—Filed May 13, 1892. Serial No. 432,874. (Specimens.)

An improved process of enameling articles, which consists in applying a thin coating so as to cover so much of the article as is desired to be enameled, then, while the thin coating is wet, in applying a second partial coating of a contrasting color in the form of spots or blotches, then in drying the article and finally in firing it.

**Letters to The Editor.**

CRITICISING ADVERTISEMENTS.

ST. JOSEPH, Mo., Nov. 16, 1894.

Editor of THE JEWELERS' CIRCULAR :

Please accept our hearty thanks for criticising our "ad." in your issue of the 14th inst., as it gives us more courage to try to make our "ads." as effective as possible.

Yours respectfully,

LOUIS BURNETT & Co.

FACTS REGARDING A MORTGAGE.

HORNELLVILLE, N. Y., Nov. 17th.

Editor of THE JEWELERS' CIRCULAR :—

In THE CIRCULAR of the 7th inst. you published the following, as a Buffalo, N. Y. local: "King & Eisele last week obtained judgment against J. B. Woodbury, as principal, and C. W. Griswold, as agent, both of Hornellsville, N. Y., for \$193.44 and costs, after a tedious trial of several days duration."

So far as I am concerned this item is wholly erroneous, and its tendency is to impair my credit. The particulars of my business relations with the Mr. Woodbury mentioned are briefly as follows :

Prior to June 5th 1893, I have been doing business as his agent. On that date all business connection between us was severed. On Sept. 26, 1893, a settlement of certain disputed matters was made between us, by the terms of which Mr. Woodbury expressly assumed and agreed to pay all the liabilities incurred in the business while I was his agent.

The judgment referred to in the item quoted above, was rendered in an action brought against Mr. Woodbury upon one of the claims thus assumed by him. It is against him alone, and was recovered in an action in which he alone was defendant. My only connection with the suit in question was as a witness, and I am in no way interested in or liable upon the judgment.

If you will kindly give this communication a place in the next number of THE CIRCULAR, you will repair so far as possible, an

injury done to my credit, and confer a favor.  
Very truly yours, C. W. GRISWOLD.

A PLEA FOR ORGANIZATION.

WORCESTER, Mass., Nov. 11, 1894.

Editor of THE JEWELERS' CIRCULAR:

I find the jewelers are alive to the necessity of a United States law that will lift the jewelry business out of the mud, and give it the dignified position it had once, and it is to be hoped will again. To assist them I have written some verses which are inclosed.

Fine gold and silver and precious gems,  
Are the pride of a jeweler's vocation,  
For all of these are fitting emblems  
Of the superior in every station.

'Tis sentiment that like the brook  
Rolls on and on forever,  
Casting one side into crevice or nook  
The dross that would clog its endeavor.

The laws of our States this sentiment says  
Should be made to strengthen the right,  
By condemning the tricks and other dark ways  
Of those who prefer darkness to light.

Knaves and fools inhabit the earth,  
Is the story we are told,  
And wealth comes slow, they say with mirth,  
If one is hampered by stamps on gold.

Am I my brother's keeper? is asked in disdain,  
And with a sense of being insulted,  
'Tis the same old question asked again  
After an injury to a brother has resulted.

Shall we who say yes, and do it with pride,  
Have an equal chance with any others?  
Or must we in an atmosphere of fraud abide,  
Compelled to be robbers, rather than brothers.

W. W. S.

TO A CHINA SHEPHERDESS.

THY curving bodice, charming dear,  
Thy golden tresses, cheeks of rose,  
Thy dainty kirtle, eyes so clear,  
Thy graceful slippers, pointed toes.

All these attract my heart to thee,  
I'll love thee though upon the shelf,  
For times are hard, and thou, I see  
Wilt make no drafts upon my pelf.

—New York World.

A BEAUTIFUL AND ACCEPTABLE HOLIDAY PRESENT

## THE REGINA MUSIC BOX

PLAYS ALL THE LATEST SONGS.

Regina Music Boxes

Play Thousands of Tunes by means  
of Indestructible Metallic Disks.  
Purity & Volume of Tone Unequaled.

New tunes issued every week. Over one thousand are now ready including dances, operatic and all the popular airs of the day.

It is a musical novelty rendering on one or two accurately tuned steel combs the most beautiful music and playing an unlimited number of tunes.

It is the first and only music box manufactured in the United States and far surpasses the finest imported ones. The mechanism is of wonderful perfection and so strong and well finished that with ordinary care it will last for a life time. It runs fifteen minutes with one winding. All its parts are interchangeable and highly polished. The tune-sheets are indestructible, being made of metal and are easily adjusted or changed. Send for illustrated catalogue.

**A. WOLFF,**  
194 Broadway, New York.

ARE YOU PUSHING THE SALE OF

# TRENTON MOVEMENTS ?

IF NOT, WHY NOT ?

For intrinsic value and great merits combined, with  
**LOWNESS of PRICE**, they far surpass any movements ever placed on the market.

A sample line will thoroughly convince you that it will be to your advantage to handle them extensively.



6 SIZE, 7 JEWELS.



16 SIZE, 16 JEWELS.

INSIST UPON HAVING THEM.

# TRENTON WATCH CO.,

TRENTON, N. J.

### Trade Gossip.

Young Bros., Providence, R. I., report trade excellent. Their large line of handsome boxes and novel display pads and trays find ready buyers.

Ferd. Fuchs & Bros., 808 & 810 Greenwich St., New York, have had a most successful season with their new style of toilet

goods and manicure articles, and they are compelled to do night work to keep up with their orders.

A new thing in the Paul E. Wirt Safety-Propelling Fountain Pen in which the protection to the pen point is absolute. The feed is the same as in the Wirt pens. The cap when reversed to the end of the holder propels the pen from the open end. When the cap is reversed for carrying in the

pocket the pen returns to the case and is submerged in the ink chamber. The pen, being always bright and moist, when pushed forward writes instantly.

On another page the Mossberg Wrench Co., Attleboro, Mass., show a novelty which jewelers should find profitable to handle. It is a handsome silver plated knife and scissors sharpener, so constructed that it has a total of over six inches of cutting surface and practically can never wear out. The cutting disks are of the very best hardened steel and do their work thoroughly in a few moments. For desk and office use it is made in a neat standard shape serving as a paper weight and ready for instant use for erasers and penknives.

"Our chains lead the world," is the watchword of Hamilton & Hamilton, Jr., Providence, R. I. This firm have had work for their employes during all the dull times, a fact which is in itself an endorsement by the trade of the selling qualities of their goods. The patterns lately added have still further strengthened the various lines and among them all there is not one design that does not find an appreciative buyer. The "King" filled chains in 14 karat gold are now made in all the popular patterns and have proved immense favorites. Dealers will bear in mind that ★ H. & H. chains are always popular and sell well.

Fred I. Marcy, whose card appears elsewhere in this issue has among some other things which he will shortly surprise buyers with, an excellent line of link buttons in silver and gold. Mr. Marcy has lost none of the vim and push which have made his name synonymous with enterprise in the jewelry trade and his many friends will learn with pleasure that his prospects are very bright indeed. The goods which the firm will show are every one of them sellers, and the samples shown convince those who see them that Mr. Marcy is closely in touch with the market and anticipates the buyers' wants.

A pleasing pin which sells as fast as it can be made is the new football player, enameled in colors, shown by Coddling Bros. & Heilborn, North Attleboro, Mass. The figure of the player, who hugs the "pig-skin" closely to his breast, is shown in full football costume, and is enameled in Princeton, Yale, Harvard, U. of P., Cornell, and all other college colors. In quick selling novelties this firm show an excellent line of links, garters, belts, picture frames, calendars, muff holders, czarinas, suspenders, buckles, etc., etc. The fashionable muff, a scrap of velvet, a bit of lace, a flower and perhaps a little fur comprise its makeup and it can be worn with nothing but the muff holder. Coddling Bros. & Heilborn, in these latter goods, believe they have the finest line in the market. A beautiful photogravure catalogue of the firm's goods will be sent on application.

J. E. Stephens, Rumford Falls, Me., is newly fitting up his store in that place.

## DIAMONDS.

# Wm. S. Hedges & Co.,

## Importers of Diamonds,

And Manufacturers of DIAMOND JEWELRY.

170 Broadway, New York.

22 Holborn Viaduct, London.

## Alfred H. Smith & Co.,

### IMPORTERS

# DIAMONDS

AND

## PRECIOUS STONES,

282 BROADWAY, COR. JOHN STREET,

NEW YORK.

22 Holborn Viaduct, London, E. C.

## R. A. KIPLING,

### Precious Stones

### AND Fancy Goods

Bought and Sold on Commission.

19 RUE DROUOT,

PARIS, FRANCE.

### "SECURITY PIN GUARD."

Can be Used on Scarf or Ladies' Pin.

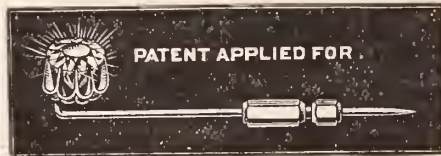

85c. Dozen Gold, \$6.00 } Doz  
Net Cash. Silver, 3.00 } Net Cash  
DISCOUNT TO JOBBERS.  
Security Mfg. Co., 7 Astor House, B'way, N.Y.



18. JOHN ST NEW YORK

**Queries by Circular Readers.**

*Editor of THE JEWELERS' CIRCULAR:*

Can you tell me what will keep a show window from frosting over? Will holes bored through the sash do it? If so, how large ought they to be and will it not make the room cold? and oblige

H. ENGLE.

ANSWER: If you will refer to THE JEWELERS' CIRCULAR of March 22, 1893, you will find on pages 35 and 36 an exhaustive article "How to Keep Show Windows From Frosting."

*Editor of THE JEWELERS' CIRCULAR:*

Will you tell me how to remove soft solder from a gold coin and leave it in good condition? J. C.

ANSWER:—On page 116, of Workshop Notes for Jewelers and Watchmakers, published by the Jewelers Circular Publishing Co. appears the following receipt for removing soft-solder from gold and silver work:

The following method is given by Mr. A. Watt: Place the soldered article in a hot solution of perchloride of iron—made by dissolving crocus or jewelers' rouge in muriatic acid—diluting the solution with four times its bulk of water, and there leaving it until the solder is removed. A formula recommended by Gee for this purpose is composed of protosulphate of iron (green copper) 2 oz., nitrate of potassa (saltpeter) 1 oz.; water, 1 oz. Reduce the protosulphate of iron and nitrate of potassa to a fine powder, then add these ingredients to the water and boil in a cast iron saucepan for some time; allow the liquid to cool, when crystals will be formed; if any of the liquid should remain uncrystalized, pour it from the crystals and again evaporate and crystalize. The crystalized salt should be dissolved in muriatic acid in the proportion of 1 oz. of the salt to 8 of acid. Now take 1 oz. of this solution and add to it 4 ozs. of boiling water in a pipkin, keeping up the heat as before. In a short time the most obstinate cases of soft solder will be cleanly and entirely overcome and the solder removed without the work changing color.

ART AS IS ART.

AUCTIONEER—Here, gentlemen, we have a masterpiece from the brush of the famous painter, Schmirinsky, in a gold frame.

ART PATRON—I offer three marks for it.

AUCTIONEER — Three marks? But, my dear sir, the picture alone is worth that much.—*German Joke.*

A PLETHORA OF RICHES.

DEJECTED YOUTH—I would like to return this engagement ring I purchased here a few days ago.

JEWELER—Didn't it suit the young lady?

DEJECTED YOUTH—Yes; but another young man had already given her one just like it, and I would like to exchange it for a wedding present.

ESTABLISHED 50 YEARS.

LANDEL, BAREMORE & BILLINGS,

IMPORTERS OF

DIAMONDS,

AND OTHER PRECIOUS STONES.

FINE PEARLS A SPECIALTY.

MANUFACTURERS OF

DIAMOND JEWELRY,

IN THE LATEST DESIGNS.

Diamonds Recut in Modern Styles or Repaired on Premises.

58 Nassau Street,  
29 Maiden Lane,  
NEW YORK.

1 Tulp Straat,  
AMSTERDAM.

1 St. Andrews St.,  
Holborn Circus,  
LONDON, E. C.



TRADE MARK.

ESTABLISHED 1841.

CARTER, SLOAN & CO.,

MANUFACTURERS OF GOLD JEWELRY,

No. 15 MAIDEN LANE,

NEW YORK.

A. CARTER JR.  
A. K. SLOAN.  
C. E. HASTINGS.

GEO. R. HOWE  
WM. T. CARTER  
WM. T. GOUGH.

FACTORY, NEWARK, N. J.



JOHN N. DISSELKOEN,

Cutter and Importer of

DIAMONDS

FACTORY  
76 LANGBLEEKERSPAD.  
AMSTERDAM.

19 East 16th St.,  
NEW YORK.

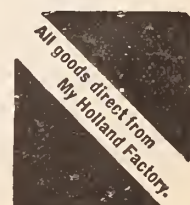

### Bicycle Clock.

It is a well known fact that every new sport calls for a number of new articles, and in this manner its performance becomes a source of profit to mechanics and factories. Again, the ordinary articles are constantly improved both in form and

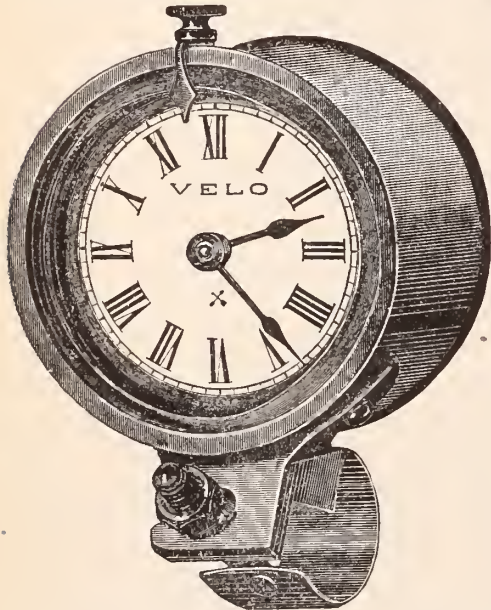

adaptability, thereby inviting the lovers of the sport to buy. These highly philosophical reflections THE CIRCULAR clips from the *Deutsche Uhrmacher Zeitung*, which this paper indulges in to introduce the bicycle clock described in the following. This timekeeper is manufactured by the Hamburg-American clock factory. It calls itself by this name because it is located neither in Hamburg nor in America, but in that part of the Black Forest belong-

ing to Wurtemberg—"a rose by any other name smells just as sweet"—at Schramberg.

The purpose, manner of fastening, etc., of the clock are so self suggestive that it is unnecessary to go into an elaborate description. In the lower attachment is fastened a piece of strong clock spring, which is bent circular; at its end it has a screw-thread with nut, which is slipped into a slot on the front foot of the bar and properly secured in place by screwing it sufficiently tight so that it will be immovable.

Immediately behind the bezel is a ring that revolves around the case, with an index, which can be set to point to the time of starting, after which it is tightened with the milled screw. The little clock is protected against dust and rain by an index rubber housing. These are about all the notable points of the description; the weight of the clock is about 8 ounces, and its price is also quite moderate, so that every cyclist can readily buy one.

**Oiling the Escapement.**—Put to the leading or entrance pallet about the same quantity of oil that you have to put to both pivots of the balance, going with small quantities at a dip, and with the tweezers or any clean instrument that has no oil on it move the fork from one banking to the other, so that the oil may be distributed on the wheel teeth as you apply it. Put no oil to the fork, or jewel pin, a moderate quantity to plate holes, put the balance in place, and if you take pride in your work, you will be likely to be satisfied with the job. Remember, no watch will hold its rate without oil at the pallets, and *no watch will hold its rate with oil in the fork.*

### Workshop Notes.

**Roller Jewel.**—The roller jewel requires careful attention in fitting it, as a great deal in the motion of a watch depends upon it. If it is not set truly straight, the rate of the watch will constantly vary with every position of the wearer.

**Cleaning and Polishing Pivot.**—After reducing the newly turned pivot to the required size with steel and oil-stone dust, take a piece of pith and thoroughly clean off all the oil-stone dust, and then, with the bell-metal polisher and a little crocus antimony, polish out all the marks left by the oil-stone dust. Carefully clean with pith, and then with a pegwood cut like the previous polisher and a little diamantine, proceed to polish until a fine gloss is obtained, and then finish with a highly polished bur-nisher.

**Oil on Endstone.**—The objection to putting oil to the endstone or cap jewel is that, in putting it to its place, the compression of the air spreads the oil all over the surfaces of both jewels, and the pivot will soon be running dry; while, if it is drawn through from the cup, there is a slight atmospheric pressure that keeps the oil right to the place where wanted, and a small quantity thus applied will lubricate the pivot a much longer time than if the cup is full, as then it is very likely to spread over staff and roller.

**Polishing.**—There is some question among watch repairers as to the best methods of polishing, and some, mostly English workmen, use medium coarse rouge after the oil-stone dust, and finish with very fine rouge instead of diamantine; and others prefer sappharine or rubytine. I have tried them all, and find that diamantine will produce a better gloss and is more satisfactory in all respects. Rouge is very slow and not so good, and while sappharine and rubytine are quicker the polish or gloss is inferior. This is my experience.

**Cleaning Solution.**—I use the following solution for cleaning a watch: One ounce ammonia, one ounce alcohol, one ounce water, one ounce Spanish whiting, ground and free from grit; the four ingredients I mix and keep in a well corked vial, using my finger at all times instead of a brush. A brush soon plays out and you get either too much or not enough of the solution. By using the finger, each time you apply the solution the four ingredients are well mixed. My next outfit is medium Manilla paper, cut in pieces  $1\frac{1}{2} \times 2$  inches and  $3 \times 4$ . This paper lasts better, protects the articles being cleaned, dries the brush and aids in giving a brilliant polish. I take the lower plate in my left hand and with the finger of the right spread a heavy coat of the solution on it, then, with a stiff brush, I commence to rub hard, and applying the solution to the back, front and sides or edges of the plate, I soon have a finish that cannot be beat; the grease and dirt are all gone. I then use the pegwood.

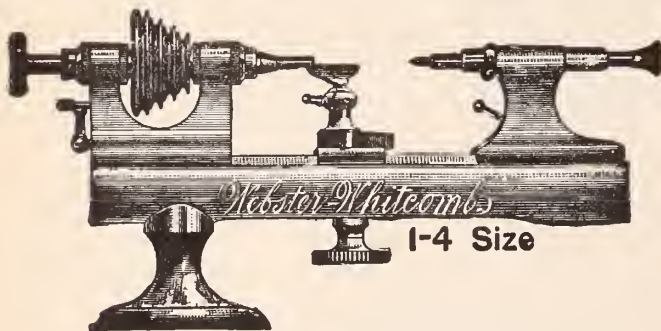

STRONGEST GUARANTEES.

Quality  
Maintained.

Prices to  
Suit the Times.

Ask for our New  
Prices and  
Terms for 1894.

**American Watch Tool Company,**

Chymistry Dist., Waltham, Mass.. Stoney Batter Works.

### Philadelphia College of Horology

Is not the largest but is the finest school in the country. A practical school to learn watch-making, engraving, and jewelry repairing. One tuition pays for all branches. Send for prospectus.

F. W. SCHULER, PRINCIPAL,  
1213 Filbert St., Philadelphia, Pa.  
Write for particulars of our corresponding course.

**H. M. RICH & CO.,**  
Jewelry · Auctioneers,  
21 School Street,  
BOSTON, MASS.



# RUDOLSTADT

## ART POTTERY.

CONTAINS all the elements required as to designs, decorations and workmanship, in a high grade of Art Goods adapted to the Jewelry Trade, and yields a larger margin of profit than any other class of Pottery.

**L. Straus & Sons,**

SOLE AGENTS,  
42-44-46-48 Warren Street,  
116 Chambers Street,  
NEW YORK.



**KETCHUM & McDOUGALL,**  
MANUFACTURERS  
GOLD & SILVER THIMBLES,  
GOLD COLLAR BUTTONS,  
AUTOMATIC EYE-GLASS HOLDERS  
198 BROADWAY N. Y.



ILLUSTRATED CATALOGUE SENT ON APPLICATION

### BORLOZ FILES. L. COMBREMONT

IMPORTER OF

Tools and Materials,

45 Maiden Lane, NEW YORK.

#### SAFES FOR JEWELERS.

MOSLER, BAHMANN & CO., 518 BROADWAY  
NEW YORK.  
Patent Fire and Burglar Proof Safes.

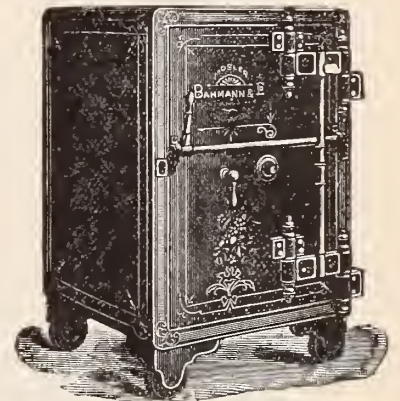

Large Assortment Always on Hand.  
Send for our Representative.  
Special Safes to Order.  
Jewelers' Safes a Specialty.

DON'T FORGET THE JEWELERS' CIRCULAR PUBLISHING CO.'S BOOK LIST when in want of any technical book in the Jewelry or Kindred Trades.

WHITE'S EYE SHADE.

**W. D. WHITE & SON**  
MANUFACTURERS OF



Spectacle and Eye Glass  
CASES

90 SOUTH STREET, BOSTON.

Special Cases made to order for Optical Trade. Cases for Trial Lenses. Opera Glasses recovered, etc. Chatelaine Spectacle Cases Metal Bound Leather Cases for combs, scissors, etc. Over forty kind of cases manufactured.

Sold by all wholesale dealers at manufacturer's price.

**A. N. CLARK & SON**  
PLAINVILLE  
CONN.

#### Manufacturer of the Celebrated LOOP WATCH KEY.

The Best for the Price in the World,  
CROSBY'S JEWELING TOOLS IMPROVED.

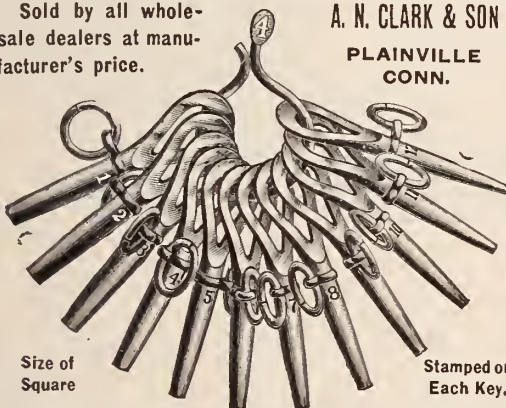

Size of  
Square

Stamped on  
Each Key.



Will quote royalty or price for the manufacturing of articles of real worth.

IMPORTERS OF  
**DIAMONDS.**

JOBBERS IN  
Watches, Jewelry, Chains,  
NOVELTIES, ETC.

Latest Designs. Lowest Prices.

**AIKIN-LAMBERT  
JEWELRY CO.,**

19 Maiden Lane, New York.

CHICAGO BRANCH: 103 STATE ST.

# FERDINAND BING & Co.,

106 GRAND STREET, N. Y.

PARIS, DRESDEN, VIENNA, ST. PETERSBURG, MOSCOW.



CHOICE SELECTIONS IN

China Clocks and Gilt Bronze Sets, Fine Painted Dresden Goods in Vases, Cups and Saucers, and Plates; Cararra Marble Statuary, French Cabinets and other Fancy Furniture.

Real Bronzes, Russian Bronzes, Art Bronzes.





## HER ROSE JAR.



11.

June roses bloomed their breath to yield  
And subtle sweets from wood and field.  
All flowers that blow from near and far,  
With fragrance crowd her quaint rose jar.

111.

I would each rose embalmèd there  
Might breathe my hopes in perfume rare,  
In all sweet scents my love lie hid  
To greet her when she lifts the lid!

AGNES LEWIS MITCHELL,  
In "Godey's."

### Early Italian Pottery.

A REPRESENTATIVE collection of Italian art from the fourteenth to the sixteenth centuries has been brought together from various sources, and is now on view in the New Gallery, London. Among other things are a couple of cases of Italian majolica of very fine quality. These examples are not often to be seen by the public, as they emanate from private collections; similar pieces are on view in our museums, but this public display of selected specimens seems a fit opportunity for calling attention to the special excellences of this beautiful and characteristic work. Italian majolica dates from about the twelfth century, and seems to have been the result

of an early attempt to rival the porcelain imported from China by the Venetians.

With rare feeling, however, the Italian keramists forbore to imitate the Chinese production, but imparted their own artistic feeling to the work. The only clay available was a common dark-colored earth, but this was coated with an opaque tin enamel which gave a pure white surface capable of receiving beautiful colors. These colors were doubtless manufactured by the artists themselves, who were thus enabled to give to the work their own individuality in a remarkable degree.

There is no doubt that the designs and decoration were executed for the most part directly upon the surface of the unburned



enamel. This rendered the work immeasurably more difficult, as every touch was permanent, but it also accounts for the marvelous blending of colors with ground and for the delicate richness of tones found in this class of work. It is interesting to note how these early potters actually courted difficulties in order to obtain the best results. The utilitarian ideas of the present day would have favored the burning of the white ground in order that the paintings might be more easily be applied. Yet this method, while vastly simpler, would have been by no means so satisfactory to the eye of the artist. The soft blues of Delft also owe their delicacy to the same cause; the ground and the painting were fired at one and the same time.

The center of the large case is crowned by a fine vase with snake handles which was made at Urbino. The subject is from sacred history and represents Moses striking the rock. Groups of figures admirably drawn fill both sides of the vase, and the harmony and richness of the colors are most satisfactory.

In the North Gallery is a case containing, among other things, a couple of very fine drug pots. These articles, which are extant in considerable numbers, are most interesting, as they serve to illustrate the fact that the potter's art was not something outside the life of the people. These jars, made for the most ordinary purposes, and inscribed with the title of their contents, are truly artistic, and we cannot help contrasting them in thought with the modern c.c. productions, with turned hoops bearing in black letters the words, "Raisins," "Sago," &c. Has the art of the people departed, and can we win it back?

The great bulk of examples in Italian majolica that have been left us are plates and dishes of various size, mostly round. Their purpose was evidently twofold. In some cases they have been pierced with holes, indicating that they were used as wall decorations; in others they have been made as tazzas by being raised on low feet, evidently for use as fruit dishes, while many of the smaller plates were put to ordinary domestic use. Still the fact remains that, whether for use or strictly for ornament, these wares are beautiful.

## The Connoisseur.

(Continued from page 65.)

### The Rambler's Notes.

WHAT THE RAMBLER SAW AND HEARD AMONG THE DEALERS IN ART POTTERY, CUT GLASS, BRONZES, ETC.

FIGURES AND METAL NOVELTIES.

AMONG the lines proving most popular for the holiday trade, which are displayed at the New York warerooms of the Bradley & Hubbard Mfg. Co., Park Place and Church St., are their figures and metal novelties in bright gold, satin silver and gold and silver finishes. The figures also include busts and groups ranging in size from the small paper weight to the large pieces for cabinets and pedestals. Jewelry cases, bonbon boxes, paper and letter racks, desk appointments and other novelties are shown in similar finishes and in many new shapes. The oxidized silver finished jewelry and bonbon boxes are especially rich in appearance.

WHITE ELITE LIMOGES.

IN their white Elite Limoges china Bavo & Dotter, 26-32 Barclay St., New York, are showing the most extensive assortment of small novelties in new shapes, that they have ever before displayed. Although in plain white, many of these pieces are so richly em-

bossed and in such graceful shapes, that no further decoration is desirable. Among the



JEWEL BOX.



HENRY TEA CADDY. novelties particularly suited for the jewelers' Xmas trade are tea caddies, picture frames, bonbon baskets, plates, bowls and trays of all descriptions; teapots, sugars and creams; A. D. coffee, tea, chocolate and ice cream sets; vases, urns and other pieces of

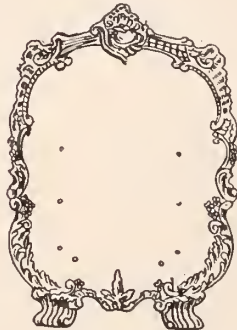

SEVIGNE CALENDAR HOLDER.

pottery; and novelties, such as brush backs, jewel stands, candlesticks, match boxes, etc.

A PUBLICATION SHOWING ORIENTAL GOODS.

ANOTHER publication, *Vantine's Monthly*, has been issued by A. A. Vantine & Co., importers of Oriental goods,

377-79 Broadway, New York. The first number, which appears for November; is similar in form and appearance to their *Wholesale Monthly* mentioned a few weeks ago. The latter was intended for circulation among the patrons of Vantine & Co., while the former is intended to go to the retail customers.

NEW ARTISTIC LAMPS.

A NEW banquet lamp shown by the Craighead Mfg. Co., at their New York warerooms, 38 Park Place, is called the Three Graces. The stem is formed of three female figures in silver finish, the subject being somewhat similar to the famous statue of that name. The stem, fount and holder are in gold finish. Another new shape has the body in one of six colors and the trimmings and foot in gilt. The firm are also making a fine display of library or table lamps which are once more in demand.

THE RAMBLER.

PERHAPS THE VASE WAS UGLY.

"Old Cobwigger is remarkably superstitious for a man of his intelligence," said Lively. "I saw him pick up an old horse-shoe the other day."

"Yes," replied Merritt, "he nailed it over that \$100 vase in his library."

"Did it bring him good luck?"

"It fell down and broke the vase."—*Tit-Bits*.

## Late Arrival of New Goods Novelties Not Shown Before

this season: we should be pleased to send you samples.

Cups and Saucers in half dozen Lacquer Cases, Gold Thistle, Kaga, Jeweled Torquoise and Garland Patterns, Small Jewel Boxes for favors, Pen Trays, Cracker Jars, Chocolate Pots, Fancy Pitchers, Vases, decorated in Gold and Silver, Metal Effects, New Shapes.



## A. A. Vantine & Co.

LARGEST IMPORTERS: JAPAN, CHINA, INDIA, TURKEY, PERSIA AND EGYPT.

Wholesale: 18, 20 and 22 East 18th St. Retail: 877 and 879 Broadway, N. Y.

ESTABLISHED 1870.



TRADE MARK.

SAMUEL C. JACKSON,

MANUFACTURER OF

FINE CASES FOR

Jewelry, Silverware, &c., also Hardwood Chests, Trays, and Sample Cases.

180 BROADWAY,  
NEW YORK.

2 MEDALS AWARDED

Wm. K. POTTER,  
TORTOISE SHELL WORKS PROV. R.I.

AT  
WORLD'S  
FAIR,  
1893.



TRADE MARK.  
Providence Shell Works, Providence, R. I.  
Correspondence Invited

JACOT & SON  
IMPORTERS AND  
MANUFACTURERS  
OF

MUSICAL BOXES 39  
Union Sq  
New York.



Perfect Construction

AND

SUPERIOR FINISH

MAKE OUR PRODUCTIONS OF  
HIGHEST GRADE.

JEWELERS and  
FANCY GOODS DEALERS

will find in our new line of

Art Metal Goods

many articles specially adapted  
to their trade.



The Finest Line of Banquet Lamps

EVER PRODUCED.

Fitted with the Celebrated "B. & H." Burner.

New and Attractive Designs and Finishes. Sure to be Ready Sellers.

We will send you our Little Book, giving more information, if you desire,  
and will be glad to have you visit our Salesrooms and see the Goods.

BRADLEY & HUBBARD MFG. CO.,

NEW YORK, PHILADELPHIA, BOSTON, CHICAGO,  
28 PARK PLACE 710 BETZ BLD'G. 160 CONGRESS ST. 204 MASONIC TEMPLE  
TO 21 BARCLAY ST. FACTORIES AND OFFICES, MERIDEN, CONN.

# HOLIDAY COLLECTION FOR THE TRADE.

## ORDER ONE.

### NOVELTIES

... FOR THE ...

### JEWELRY • TRADE.



THE FOSTER PATTERN



RICHFIELD PATTERN.



THE ROSE PATTERN.

Our \$75 assortments are  
a Specialty and form a  
complete collection.

P. H. LEONARD, 76 & 78 Reade Street, NEW YORK.

## MATTERS IN JEWELRY STOREKEEPING.

That this department shall prove mutually beneficial to our readers, it is desirable that the members of the trade generally communicate with THE CIRCULAR regarding any advantageous device or plan that they are utilizing in the conduction of their business.

### A Unique and Improved Business Card.

THE business card of Edward B. Fox, optician, 1326-28 Chestnut St., Philadelphia, Pa., has three coupons attached, one side of which reads:

If this coupon is slipped in spectacle or eye glass case, my address will be at hand when needed.

OVER

and the other:

EDWARD B. FOX,  
OPTICIAN,  
ROOM 408 HALE BUILDING,  
ELEVATOR. 1326-28 CHESTNUT ST.  
OVER PORTER & COATES' BOOK STORE.

OVER

Mr. Fox is up-stairs in a big office building, and hit upon this plan to connect himself with a well-known entrance, which is depicted on the reverse of his business card. The scheme will prove effective to opticians and jewelers located as is Mr. Fox.

### A Curious Window Show.

LOU PHILBIN, of the C. H. Ankeny Co., Lafayette, Ind., who has an established reputation for novel and attractive window displays, had a unique display recently. It consisted of a triangular box within which was a large disk pivoted so as to revolve freely, and three lively mice. The sides of the triangle were extended beyond the glass boundary which formed the front, and covered with mirrors, which reflected what was going on within the triangle. The mice and the disk constituted the show. A little platform lead up from the bottom

of the box to the edge of the disk, and when Mr. Mouse stepped off of it on to the edge of the disk the latter began to revolve. The feet of the little fellow began to move in rapidly accelerating motion, and the show was "on." Once in a while the apparatus got to going so fast that the mouse was hurled off of the periphery of the disk, and all fell in a heap on the floor; but he seemed to enjoy it, and in a minute or two was up again and at it. Sometimes two, or all three, of the mice, would be taking a ride at the same time. Among them they managed to keep the wheel in pretty active revolution most of the time, and it was really a novel and interesting sight.

### Points in Advertising.

A unique advertising device and one of genuine usefulness is the little spirit level sent out by the Chrome Steel Works, Brooklyn, N. Y. The level is of nickel plated steel of the company's own manufacture. The virtues of Chrome steel in the manufacture of safes, dies, etc., is universally recognized.

Julius C. Walk & Son, Indianapolis, Ind., displayed in their window recently the mounted head of a 35 pound muskallonge. Between the monstrous open jaws was a card reading "For information step inside."

Convenient little leather bound memorandum books and watch cases, bearing a neat little advertising card of Horace A. Comstock, Indianapolis, Ind., have found great favor with his friends and customers.

C. B. Duckworth, jeweler, Pawtucket, R. I., has a neat idea for card advertising in his window. Well executed pen portraits of citizens known for their shrewdness in certain lines of business are placed in conspicuous positions and these contain appropriate testimonials in regard to the solid citizens and the lines of goods Mr. Duckworth carries.

Charley Bard, jeweler, Sedalia, Mo., had on exhibition recently in his show window a jar containing a large number of pennies. He offered to the closest guesser to the number a gold ring set with a diamond. The total number was 3,344 one-cent pieces. The lucky guesser was Harry Photenhauer, his guess being 3,337. The guessing was free to all, no one being required to make a purchase in order to compete for the prize.

### A Telling Announcement.

THE following was an "ad." in a recent issue of a Hartford, Conn., newspaper:

#### Appointed Official Railroad Watch Inspector.

Mr. Charles Teske, the expert watchmaker and adjuster, has been appointed watch inspector by the Philadelphia, Reading and New England Railroad Company. The following certificate, one of many similar ones Mr. Teske can show, tells the reason why:

HARTFORD, Sept. 10, 1893.

Accidentally dropping my Howard watch and breaking the balance staff, etc., I placed it in the hands of Charles Teske, the watch and chronometer maker, at 214 Asylum St., for repairs. Since then it has run closer than at any time previous, showing a variation of but four seconds in a month.

Owners of watches requiring close time, especially railroad men, will do well to patronize Mr. Teske. C. M. Lawler, General Manager, Philadelphia, Reading and New England Railroad Company.

## A MOVING DISPLAY

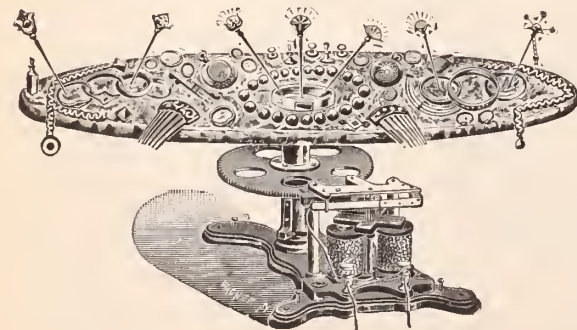

### FOR THE HOLIDAYS.

The Best Attraction in the World—a Moving Advertisement in a Window.

#### OUR ELECTRIC REVOLVING SHOW STANDS

Are of various styles, made especially for jewelers. They are equivalent to a four fold increase of Show Window space. It runs steadily ten hours per day, at an expense of two cents per day. Made to be operated by either battery or electric light current.

Send for Circular of Illustrations.

FREDERICK PEARCE,

77 & 79 John St., N. Y.

## ENAMELERS

Of GOLD, SILVER AND PLATED JEWELRY.  
Enameled, Plain and in Colors.

ALSO OF . . .

SOCIETY EMBLEMS,  
YACHT AND COLLEGE FLAGS.

All Varieties of Painted Enamel Work.

S. S. WILD & SON,

179 Eddy Street, PROVIDENCE, R. I.

Correspondence Solicited.

Telephone Connection.

# A. J. HEDGES & CO.,

MANUFACTURERS OF

Gold, Variegated and Enameled Jewelry.

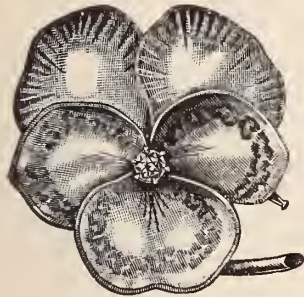

BLACK AND WHITE ENAMELED GOODS  
— A SPECIALTY. —

SIDE COMBS AND COLLARETTES, LACE PINS, SCARF PINS,  
BROOCHES AND PENDANTS, CHATELAINES AND  
BRACELETS, LINK BUTTONS AND STUDS, LADIES'  
AND GENTLEMEN'S GOLD AND SILVER GARTERS.

FACTORY:  
90 Mechanic St., Newark, N. J.

6 Maiden Lane, New York.

# L. SAUTER & CO.,

Dealers in Diamonds



. . . AND . . .

Makers of Fine Jewelry,



194 BROADWAY, NEW YORK.

Selection Packages sent on request. Mounting of Diamonds and other  
precious stones in new and original designs a specialty.

**W. H. SCHWARTZ & CO.**  
MANUFACTURERS OF FINE  
**JEWELRY**  
AND  
NOVELTIES  
IN GOLD AND SILVER.  
355 Mulberry Street.  
Newark, N. J.

# HAGAN, WHITE & CO.,

MANUFACTURERS OF

GOLD AND SILVER MOUNTED CANES, UMBRELLAS & NOVELTIES.

RICH AMERICAN CUT GLASS, SILVER MOUNTED.  
248 WEST 23D STREET, NEW YORK.

# HILDRETH M'F'G CO.,

53 MAIDEN LANE, NEW YORK.

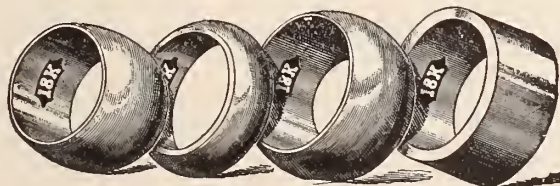

Standard Quality. Standard Prices. Finest Finish.  
Plain Solid Gold Rings.

# A RICH COMBINATION.



Cut Glass Bowl on Artistic Solid Cast Brass Base, Fin-  
ished in Matt and Burnished Gold.

The Combination of Gold and Cut Glass  
shown above was a most daring one. Its  
INSTANT and INCREASING SUCCESS is a  
proof that the trade appreciates it as a  
SELLER. Write us at once for full partic-  
ulars and prices if you are not carrying it.

A Specially Good Thing for Jewelers.

# T. B. CLARK & CO., Inc.,

860 Broadway, N. Y.,

Factories, HONESDALE, PA.

N. E. Cor. 17th St. & Broadway

# LATEST STYLES

. IN .

# FINE JEWELRY.

GOLD BUCKLES,  
HAIR PINS,  
BACK COMBS,  
SIDE COMBS,  
NECK ORNAMENTS, Etc.

John A. Riley & Sloan Co.,

Broadway and 17th Street,

NEW YORK.

# CARBORUNDUM.

## Net Retail Price List of Carborundum Wheels.

ACCESON'S PATENT, February 28th, 1893.

Diam. in Inches	THICKNESS IN INCHES.																		Rev. per Minute.
	1/4	3/8	1/2	5/8	3/4	7/8	1	1 1/4	1 1/2	1 3/4	2	2 1/4	2 1/2	2 3/4	3	3 1/2	4		
1	\$.15	\$.18	\$.20	\$.23	\$.25	\$.28	\$.30	\$.35	\$.40	\$.45	\$.50	\$.55	\$.61	\$.65	\$.70	\$.80	\$.90	18,000	
1 1/2	.18	.22	.25	.28	.31	.33	.35	.40	.45	.50	.56	.62	.67	.73	.78	.90	1.00	14,000	
2	.20	.25	.30	.34	.37	.40	.42	.46	.52	.58	.65	.70	.77	.85	.91	1.00	1.00	11,000	
2 1/2	.25	.30	.37	.42	.46	.48	.50	.55	.60	.67	.75	.80	.91	.98	1.05	1.20	1.40	8,800	
3	.30	.38	.45	.50	.55	.58	.60	.65	.70	.78	.85	.95	1.05	1.15	1.25	1.45	1.65	7,400	
4	.65	.70	.75	.80	.85	.90	.95	1.10	1.30	1.50	1.65	1.80	2.00	2.15	2.35	2.70	3.05	5,500	
5	.85	.90	.95	1.05	1.15	1.25	1.35	1.65	1.90	2.20	2.45	2.75	3.05	3.30	3.55	4.15	4.65	4,400	
6	1.10	1.20	1.25	1.45	1.60	1.80	1.95	2.35	2.75	3.15	3.55	3.95	4.33	4.75	5.15	5.95	6.75	3,700	
7	1.35	1.55	1.70	1.90	2.10	2.35	2.60	3.15	3.70	4.25	4.80	5.35	5.75	6.45	7.00	8.10	9.20	3,160	
8	1.65	1.90	2.15	2.45	2.75	3.05	3.35	4.05	4.80	5.50	6.25	6.95	7.65	8.35	9.10	10.50	12.00	2,750	
9	2.00	2.40	2.65	3.10	3.40	3.80	4.15	5.10	5.45	6.90	7.80	8.75	9.65	10.55	11.45	13.25	15.10	2,450	
10	2.45	2.80	3.25	3.70	4.15	4.65	5.10	6.25	7.40	8.50	9.60	10.70	11.85	12.90	14.05	16.30	18.55	2,200	
12	3.60	4.00	4.40	5.10	5.80	6.50	7.20	8.80	10.40	12.00	14.60	15.20	16.80	18.41	20.00	24.55	26.40	1,830	

CARBORUNDUM was awarded both a Medal and a Diploma at the World's Columbian Exposition in recognition of its merits as an Abrasive, the hardness being greater than any other abrasive material.

The wheels are made with a vitrified bond, and pressed under hydraulic pressure. Those over three inches in diameter are turned up after firing. The same numbers are used to designate the degrees of fineness, as are used with Emery, and the wheels are made in seven degrees of hardness, marked SSS, SS, S, M, H, HH, HHH, from extremely soft to extremely hard.

In ordering, state diameter, thickness, hole, number and hardness.

Monongahela, Pa., U. S. A.

THE CARBORUNDUM COMPANY.

Hones, Slabs, Files.

Cut = This = Out.

## BOYLE, DAVIS & GOODMAN,

SPECIAL AUCTIONEERS for the Legitimate Trade only.

63 Fifth Avenue  
NEW YORK.

611 Pennsylvania Ave.,  
WASHINGTON, D. C.



S. A. BOYLE.



W. M. DAVIS.



CHAS. P. GOODMAN.

WE PAY ALL OUR OWN EXPENSES. GUARANTEE TO MAKE YOUR SALE WITHOUT LOSS.

SEND FOR OUR BUSINESS PAMPHLET.

CONSULT US BEFORE PLACING YOUR SALE. ADDRESS ALL CORRESPONDENCE TO OUR WASHINGTON OFFICE.

SPECIAL SALESMAN OF

WATCHES, DIAMONDS,

Bric-a-Brac  
and Art Goods

FOR

Established Jewelers.

WRITE FOR PARTICULARS.

Communications Strictly Confidential.

References given in all parts of the United States from Retailers and Jobbers.

Jules Jürgensen

OF COPENHAGEN.

The reputation these watches have maintained for Fifty Years has never been equalled, being made on strictly scientific principles and no expense spared to give the Best results in mechanism and timekeeping qualities.

SOLE AGENTS,

John C. Hyde's Sons,

NO. 22 MAIDEN LANE.

For BADGES and MEDALS,

Flag Pins, Class Pins, Class Rings  
and Special Work of all Descriptions,

SEND TO E. R. STOCKWELL, MANUF'R,  
19 John Street, New York.



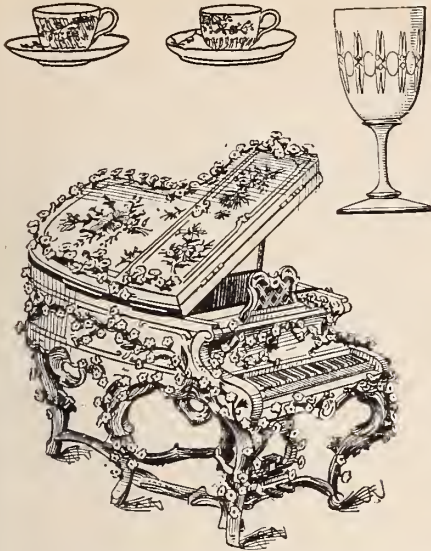

# HINRICHS & CO.,

29 & 31 Park Place, N. Y.

## HOLIDAY GOODS FOR JEWELERS.

ITALIAN MARBLE BUSTS,  
 PARIAN BUSTS and FIGURES,  
 BISQUE FIGURES and GROUPS,  
 FRENCH CHINA CRACKER JARS,  
 CHOCOLATE POTS, TRAYS, BOWLS,  
 SOUVENIR A. D. COFFEES, TEAS, Etc.

ST. GERMAIN AND GERMAN-AMERICAN STUDENT LAMPS.

### BRIC-A-BRAC AND ART POTTERY.

SEND FOR CATALOGUES.



## FANCY

.. IN ..

SCARF PINS

AND LINKS.

Dudes, Chinamen, Policemen, Sailors, Orators, Cadets, and all other Shapes Made.  
 SEND FOR SAMPLES.

If your Stock does not include our **GOLCONDA GEM** Line you are losing sales. This Stone is Mounted in Studs, Scarf Pins, etc., in Solid Gold and Plate.  
 If your jobber doesn't keep these goods write us and we will send you the address of a jobber in your vicinity who does. Every card bears the words "THE GOI CONDA GEM, Reg'd." all others said to be "equally as good" are spurious. Bear this fact in mind.

R. L. GRIFFITH & SON, = PROVIDENCE, R. I.



## FIGURES

STERLING SILVER,

Enameled in Colors.

QUICK SELLERS.

WM. SMITH & CO.,

Manufacturers of Gold, Silver and Roll Plate Chains and Jewelry.



Novelties in Gold and Silver Bead Necklaces and Bracelets. Also a large line of Chain Trimmings and Silver Rings.

Office: 5 and 7 Maiden Lane, New York.      Factory: 61 Peck Street, Providence, R. I

T O W L E MANUFACTURING COMPANY,

SILVERSMITHS,



Old English Coffee Spoon,

NEWBURYPORT,

149-151 STATE STREET,  
 CHICAGO, ILL.



TRADE MARK

CHRYSO-CERAMICS,  
 GOLD COVERED PORCELAIN.

M. & E. HEALEY,

1122 CONNECTICUT AVE., WASHINGTON, D. C  
 MEDAL AT WORLD'S COLUMBIAN EXPOSITION.

## CAMPBELL-METCALF SILVER CO.

FACTORY:  
 STEWART ST.,  
 PROV., R. I.

N. Y. OFFICE:  
 2 MAIDEN LANE.

SAN FRANCISCO:  
 112 KEARNY ST.

THE  
 "ETON"  
 ... IN ...  
 CREAM LADLES  
 ORANGE  
 SUGAR  
 JELLY  
 BON BON  
 SUGAR SIFTER  
 SARDINE FORK  
 BUTTER KNIFE  
 BUTTER PICK  
 CHEESE KNIFE  
 OYSTER FORKS  
 ETC.



OUR  
 "ETON"  
 AND  
 "STUART"  
 PATTERNS

ARE IMMENSELY  
 POPULAR  
 AND SELL AT SIGHT

WRITE DIRECT  
 TO FACTORY FOR  
 SAMPLES  
 AND PRICES.

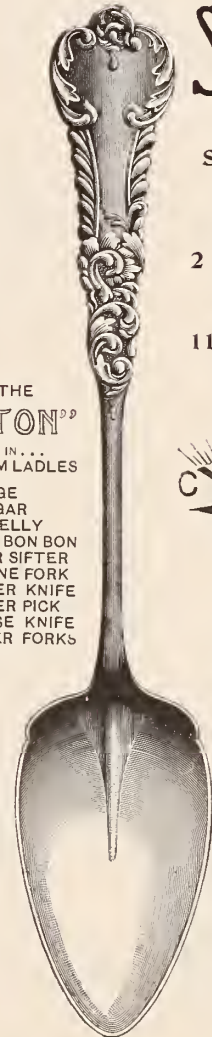

# PEARLS.

**E. KIPLING,**

182 Broadway, New York.

ELEVATOR ENTRANCE, 2 JOHN ST.

**B. & W. B. SMITH,**  
220 W. 29th St., New York.

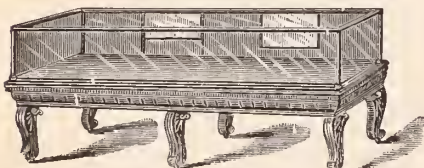

Improved Dust-Tight Counter Cases,  
Perpendicular Sliding Doors.

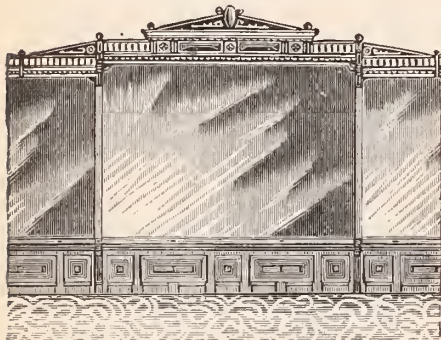

Improved Dust-Tight Wall Cases.  
Furnished with Improved Shelving and arranged for Electric Lighting.

### Diamond Polishing Machines.

We build these machines complete with latest improvements also polishing wheels, tongs, dous, weights, shafting, belting, ventilating fans, gear-cutting, die blanks, etc., We do general repair work on jeweler's machinery.

**THE ARTHUR CO.,**  
General Machine Works,

86 JOHN STREET NEW YORK.

### U.S. SMELTING & REFINING WORKS,

Sweep Smelting and Assaying, Platinum in Plate and Wire. Chemically Pure Copper. Ore and Bullion Assays a specialty.

Highest prices paid for old gold and silver.  
Sole manufacturers of Phoenix Flux and Eureka Alloy.

M. WOLLSTEIN, 25 John St., New York.



OUR SPECIALTY  
The Largest Stock of  
CHIMING  
AND  
STRIKING  
HALL CLOCKS

ever shown.

**Chas. Jacques**

CLOCK CO.,  
22 Cortlandt Street,  
NEW YORK.



## REORGANIZATION SALE OF Opera and Field Glasses.

We have for immediate sale the largest and best selected stock of Opera and Field Glasses in this country, and offer them at fully 25 per cent. below cost. A few specimen items:

- 75 Non-Achromatic Field Glasses**, 24 lines objective, in case,  
REGULAR PRICE, \$3.25, REDUCED TO.....\$2.00
- 50 Colmont Field Glasses**, 26 lines objective, in case,  
REGULAR PRICE, \$6.00, REDUCED TO.....\$4.90
- 85 Non-Achromatic Opera Glasses**, 15 lines objective, in case,  
REGULAR PRICE, \$9.00 per doz., REDUCED TO.....\$5.25 per dozen
- 50 Achromatic Opera Glasses**, leather covered and japanned, 15 lines objective, in case,  
REGULAR PRICE, \$1.75 each, REDUCED TO.....\$1.35 each.
- 50 Achromatic Opera Glasses**, leather covered and japanned, finer quality, 12 lines objective, in pocket book case, REGULAR PRICE, \$2.25 each, REDUCED TO.....\$1.55 each.
- 40 Achromatic Opera Glasses**, pearl covered, 15 lines objective, in case,  
REGULAR PRICE, \$3.75 each, REDUCED TO.....\$2.90 each.
- 36 Achromatic Opera Glasses**, pearl covered, 17 lines objective in case,  
REGULAR PRICE, \$4.50 each, REDUCED TO.....\$3.70 each

SEND FOR SAMPLES.

**QUEEN & CO., Opticians,**

J. G. GRAY, Assignee.

1010 Chestnut St., Philadelphia.

**L. LELONG & BRO.,**

GOLD AND SILVER

**Refiners, Assayers and Sweep Smelters,**

SOUTHWEST CORNER HALSEY AND MARSHALL STREETS,

**NEWARK, N. J.**

**SWEEPINGS A SPECIALTY.**

# ALBERT LORSCH & Co.,

37 MAIDEN LANE, NEW YORK.

Branch, 167 Weybosset Street, Providence, R. I.

IMPORTERS OF DIAMONDS,

Rose Diamonds, Rubies, Sapphires, Emeralds, Opals, Moonstones,  
Fancy and Imitation Stones, Novelties.

SOLE OWNERS AND IMPORTERS OF

*The Sumatra Gem.*

REG'D, UNEQUALLED IN  
BRILLIANCY AND  
HARDNESS

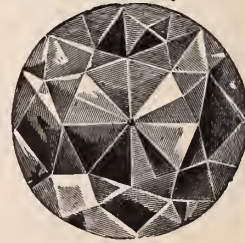
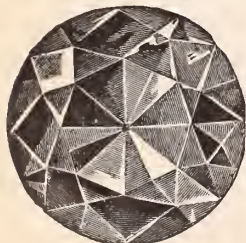

HIGHEST AWARD AT THE COLUMBIAN EXPOSITION, CHICAGO, 1893.

IT PAYS TO KEEP IN TOUCH WITH TRADE AFFAIRS. THE JEWELERS' CIRCULAR, For 4c. a Week will do it. **Subscribe.**

DIAMONDS and Cutters. L. & M. KAHN & CO., 172 Broadway, New York.



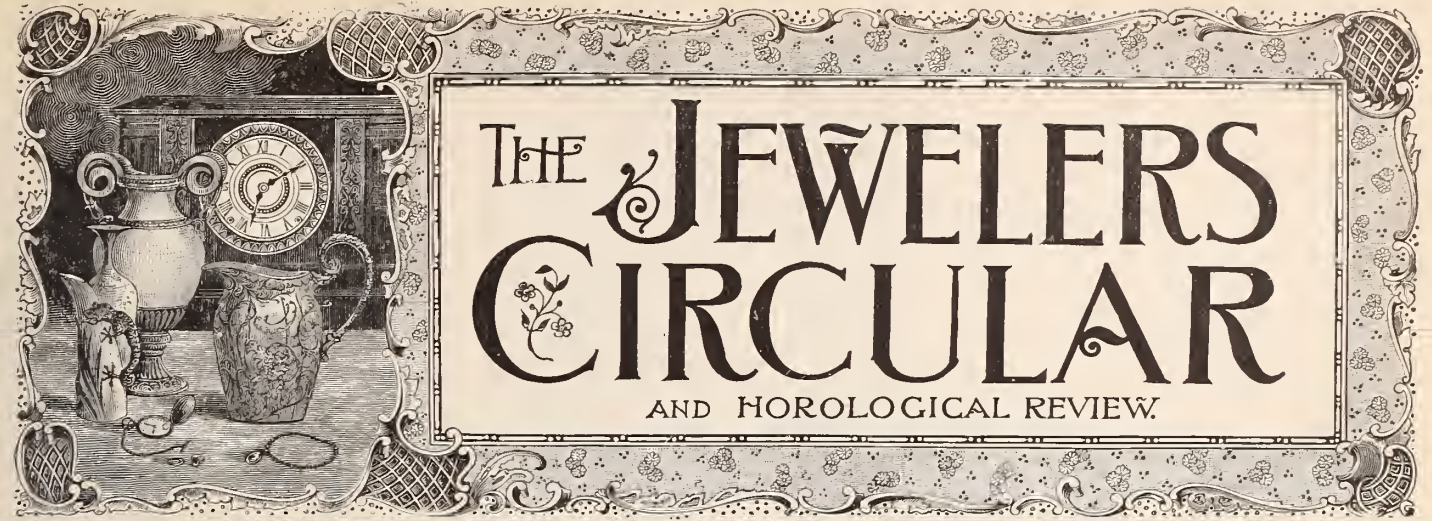

Copyright by THE JEWELERS' CIRCULAR PUB. CO.

189 Broadway, New York.

Entered at the Post Office in N. Y. as second-class matter.

VOL. XXIX.

NEW YORK, WEDNESDAY, DEC. 5, 1894.

NO. 19.

THE WORKS OF A FAMOUS CISELEUR.

UNDER the caption of The Artists of Industry, *L'Art Décoratif Moderne*, formerly published under the name of *Les Arts du Métal*, of Paris, France, 1894, reproduces a number of the excellent works of Emile Vernier, of which THE CIRCULAR copies an important example.

Emile Vernier was born at Paris, in 1852, and is the adherent of no school, as he received his artistic education in the workshop; the art of drawing he acquired at the evening classes in Paris. Strange though as it may seem, this remark is interesting—more than that, it is portentous, because it also applies without exception to all the French artists who today occupy the highest place in the domains of industry. THE CIRCULAR is far from wishing to imply by this statement that schools are bad, but there may be something in their rules by which true inborn genius is handicapped. As artist he worked for a few years for several persons, he remaining unknown, while they became famous by his works, until finally he opened an atelier on his own

Holbein a panel of iron *cisele repoussé* and *champlevé*, damaskeened with gold and

artist to the reader of this article.

The shield seen on this page is of historic interest. Readers will remember that about 16 years ago a war was imminent between the Argentine Republic and Chili, owing to some dispute about their boundary lines. The United States offered its mediation, which was accepted by both contestants, and General Thomas Osborn was designated to represent it. The general discharged the duties of his delicate mission to the entire satisfaction of both, and the Argentine Republic, desiring to tender a substantial token to the mediator, instructed Mr. Paz, its general consul at London, to have made in Europe some object of art to be offered as a souvenir to General Osborn. Mr. Paz ordered of Gustave Doré, a design for a shield—the form chosen for the souvenir as being highly appropriate to the nature of the service rendered. Gustave Doré designed a large and magnificent composition, embracing several allegories, and the work of preparing the preliminary



SHIELD REPRESENTING THE PEACE OF ARGENTINE AND CHILI.

account, and in 1876 sent to the Salon Hans

meagre remarks sufficiently introduce the

labors in gold was one of the last pieces executed by the celebrated and able gold-



CHICAGO,  
133 & 135 WABASH AVENUE.

LONDON,  
23 FORE ST., E. C.

-----THE-----

# Ansonia Clock Company,

11 CLIFF STREET,

P. O. BOX 2304,

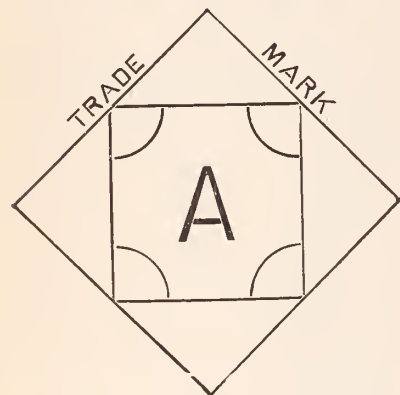

NEW YORK.

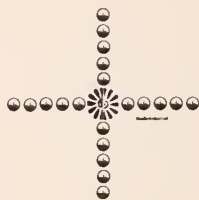

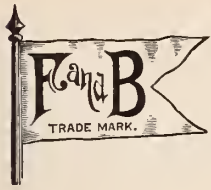

# Foster & Bailey,

MANUFACTURING JEWELERS AND SILVERSMITHS,



100 Richmond St., Providence, R. I.

**S**TERLING SILVER  
MANICURE SETS,

925-1000 Fine,

With Shoe Horn and  
Shoe Buttoner.

MADE OF THE BEST STEEL PARTS.

Put up in Fine Leather Roll,  
Lined with Dark Green Velvet  
and Having Beautiful Silk Flaps  
to fold over.

When Rolled Up it is Soft,  
Pliable, and Just the Thing to  
Pack in a Grip.

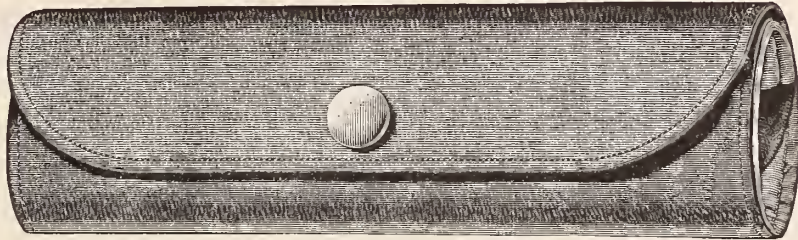

SET ROLLED UP—REDUCED ONE HALF EACH WAY.

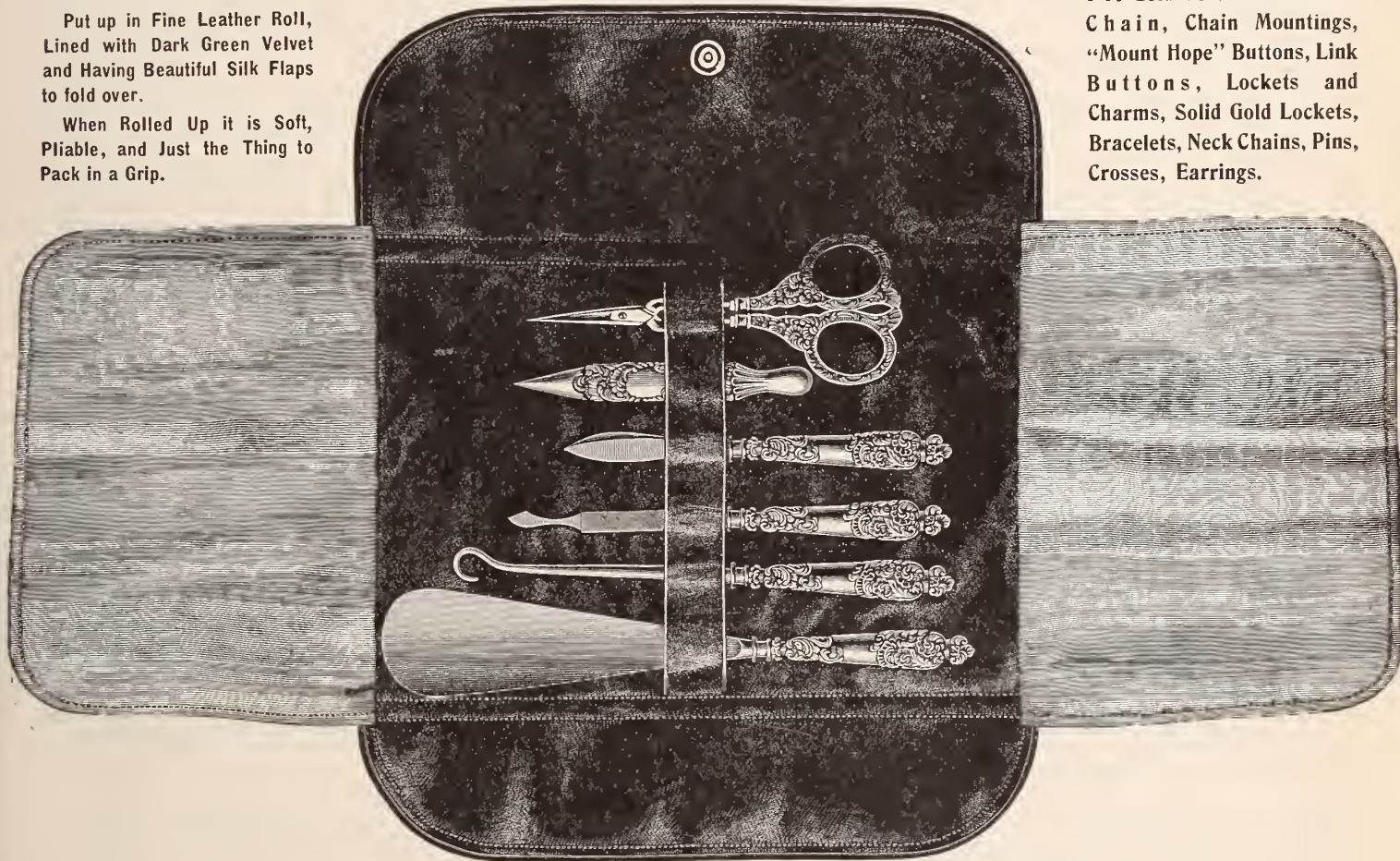

NO. 7 SET—REDUCED ONE HALF EACH WAY.

No. 138 File and Cuticle Knife Combined.  
" 139 Corn Knife.

No. 140 Button Hook.  
" 141 Shoe Horn.

No. 142 Nail Cleaner and Ear Spoon.  
" 143 Curved Scissors.

MANICURE SETS IN FINE KID CASES.

## STERLING SILVER SET No. 1, CONTAINS :

No. 54 = Tray.	No. 57 = Paste Box.	No. 59 = Corn Knife.	No. 70 = Long Scissors.
" 55 = Polisher Box.	" 57 = Powder Box.	" 60 = Cuticle Knife.	Box.
56 = Polisher.	" 58 = File.	" 61 = Short Scissors	

No. 2 and No. 3 also in Sterling Silver, with less pieces, therefore cheaper in price. Nos. 4, 5 and 6 are in 1-10 Gold. All parts can be ordered separately, and all steel is of the best.

# Diamonds

.. AND ..

# Diamond Jewelry

.. FOR THE ..

## HOLIDAYS.

We have an unusually large stock  
of mounted goods all set in the  
latest designs of mountings  
and at prices that cannot  
be beaten.

We have imported a large reserve stock  
of Diamonds, and will not advance any  
of our prices at present. Dealers making  
their selections now will have the full  
advantage of the low tariff prevailing  
on Diamonds before the Wilson Bill  
went into effect.

You can save 15 per cent. by buying  
your Holiday Stock now.

If inconvenient to call upon us, or if  
you have a call for some special article  
not in your stock, let us send you a  
selection package.

## Cross & Beguelin

Loose—DIAMONDS—Mounted.

17 Maiden Lane,

New York.

43 RUE MESLAY, PARIS.

smith, Froment Meurice.

The central piece of this shield represents the Argentine Republic and Chili shaking hands under the ægis of the United States; the people of the two nations cast away their arms and gather the instruments of labor. Three allegories surround the center piece: agricultural prosperity, industrial prosperity, and civilization—replacing savage condition. At the head of the shield, which is of oval form, is a gold ribbon, with the dedication of the Argentine Republic to General Osborn, placed upon sheaves, bunches of grapes and leaf-work.

The chasing was confided to Emile Vernier, who discharged this artistic work with consummate skill; and, indeed, it was no easy job, as will be seen by studying the illustration. "At the present moment," says *L'Art Décoratif Moderne*, "when we agitate the subject of artists signing their works, it is well to state that Mr. Froment Meurice spontaneously asked Mr. Vernier, his chaser, and Mr. Cameré, his designer, who had modified a few small parts of Mr. Doré's design and also sketched the border, to place their names upon the shield, alongside of that of the author of the composition."

### The Assignment of Adolph Kann.

WASHINGTON, D. C., Nov. 27.—Adolph Kann, jeweler, doing business at 935 F. St. N. W., has made an assignment to James H. Clark for the benefit of his creditors. His liabilities are placed at \$2,482.05 with estimated assets at \$824.60. The latter consist of stock, safe and fixtures.

The following is a list of the creditors, with the amounts of their claims:

E. Wertheimer & Co., New York, \$107; Fink, Bodenheimer & Co., New York, \$45; M. Klughertz, New York, \$400; Fred. Kaufman, New York, \$180; Levy, Dreyfus & Co., New York, \$180; Adolph Goldsmith & Son, New York, \$170; E. Heidenheimer, Washington, \$53; J. R. Harris & Co., Washington, \$24; M. Hoffa, Washington, \$40; The Post, Washington, \$20; The Star, Washington, \$80; The Times, Washington, \$1.05; M. Merrick, Washington, \$40; Mr. Lyon, Washington, \$50; J. J. Levy, New York, \$50; B. Burnstein, Washington, \$300; A. Burnstein, Washington, \$100; C. T. Anderson, Reading, Pa., \$35; ——— Adler, New York, \$71; ——— Pynofoto, New York, \$79; Wm. Kann, Baltimore, \$18; Leopold Weil & Co., New York, \$14; Waterbury Watch Co., Waterbury, \$63; Waterbury Clock Co., Waterbury, \$32; Miss Oppenheimer, Washington, \$100; Mosler Safe Co., New York, \$135; H. A. Clark & Son, Washington, \$50; J. A. Goldstein, Washington, \$45.

### Jules Jürgensen

OF COPENHAGEN.

The reputation these watches have maintained for Fifty Years has never been equalled, being made on strictly scientific principles and no expense spared to give the Best results in mechanism and timekeeping qualities.

SOLE AGENTS.

John C. Hyde's Sons,  
NO. 22 MAIDEN LANE.

### Among the African Diamond Mines.

THE ANNUAL MEETING OF THE DE BEERS CONSOLIDATED MINES, LIMITED—CECIL RHODES ON THE FUTURE BUSINESS IN DIAMONDS.

KIMBERLEY, Oct. 29, 1894.—The annual meeting of the De Beers Consolidated Mines, Limited, is one of the events of the year in the local diamond industry. On this occasion the chair was occupied by Cecil John Rhodes, one of the founders of the great concern, who has become, mainly through the diamond industry, one of the prominent men of the day within the British Empire. This gentleman has had a remarkable career, as I have from time to time disclosed, and to-day is the most powerful figure on this continent.

In his speech he related how during the past twelve months diamonds have been produced of the value of £2,820,172, for an expenditure of £1,690,585, and that altogether there had been a profit to the shareholders of £1,233,197. These figures are interesting as showing the magnitude of the industry and the profits that are possible in what is considered such a bad period as the last year. Looking at it from a financial point of view Mr. Rhodes and his co-directors may certainly be congratulated on having got hold of what is evidently for the present at any rate a good thing. As long as there are ladies, Mr. Rhodes assured the shareholders, there will be a demand for diamonds, and as long as there is a demand for diamonds, De Beers will be able to supply them. "Endless development," said Mr. Rhodes, "is before us; the life of the mines is practically unlimited." Such a prospect is no doubt calculated to put De Beers shareholders in good spirits, and the result of their good spirits is traceable in the enhanced market value of the shares.

From the proceedings at the meeting it appears that the average price per karat last year was only 24s. 6d. as compared with 29s. 6d. in the preceding years, and that this represented a difference in the earnings of the company of nearly £500,000. It was stated by Mr. Rhodes, as showing how depressed the world has been in its trade and commerce, that during the last 18 months the purchasing power of America has been less by 75 per cent. than usual.

As to the future Mr. Rhodes declared: "We have got our productions to the lowest limit possible, and what we may hope is that the diamond merchants may ask for a larger quantity. We can produce three, even four times the present quantity, but what we shall produce is just what the world requires. We have never failed in our dividend and we see no possibility of our ever failing." This dividend, I may remark, has been at the rate of 8½ per cent. on the original value of the mines when they were amalgamated.

ST. GEORGE.

*Pairpoint*

# MANUFACTURING COMPANY.

## Gold and Silver Plate



No. 3749 MATCH HOLDER.

WE ARE MAKERS OF THE  
LARGEST AND LOWEST PRICED

.....LINE OF.....

“Crown Pairpoint” China

Rich Cut Glass,

Fine Decorated Art Goods,

.....TO BE FOUND IN THIS COUNTRY.



No. 4908. SMOKING SET.

“WHEN IN DOUBT”

--- BUY ---

☀ PAIRPOINT GOODS.

Factories, New Bedford, Mass.

### HOLIDAY NOVELTIES

.....OF EVERY DESCRIPTION.

**FREE**

OUR LATEST

SILVERWARE CATALOGUE No. 10, or  
CUT GLASS CATALOGUE No. 11

Will be mailed you upon receipt of address.

SALESROOMS :

NEW YORK, 46 Murray Street.

CHICAGO, 224 Wabash Avenue.

SAN FRANCISCO, 220 Sutter Street.

MONTREAL, P. Q., Temple Building.

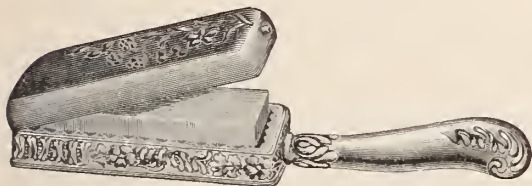

No. 2832. KNIFE SHARPENER.

### CROUCH & FITZGERALD.

Jewelry Trunks  
and Cases,  
161

Broadway,  
Bet. Cortlandt and  
Liberty Sts.,  
688 B'way,  
701 6th Ave.,  
NEW YORK

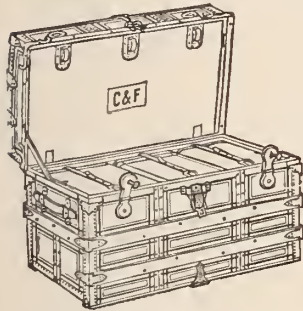

FLAT WARE AND  
HOLLOW WARE  
STAMPED



IS THE GENUINE.  
Manufactured by

WM. ROGERS M'F'G CO.,  
HARTFORD CONN.

**ALBERT BERGER & CO.**  
47 MAIDEN LANE, N. Y.  
Spectacles & Optical Goods,  
GROUND LENSES A SPECIALTY.

We sell to the legitimate Jewelry and Stationery  
trade only.



NEW YORK

CITY, U.S.A

## CHOICE PAPERS

MAKERS OF

# FINE STATIONERY

For Correspondence, Wedding and Business Use, handsomely  
boxed, specially suited to the Jewelry Trade.

18 MURRAY STREET, NEW YORK.

# R. WALLACE & SONS MFG. CO.

## SILVERSMITHS,

WALLINGFORD, - - - - - CONN.



No. 8. TEA BALL AND No. 39. TEA BALL HOLDER.

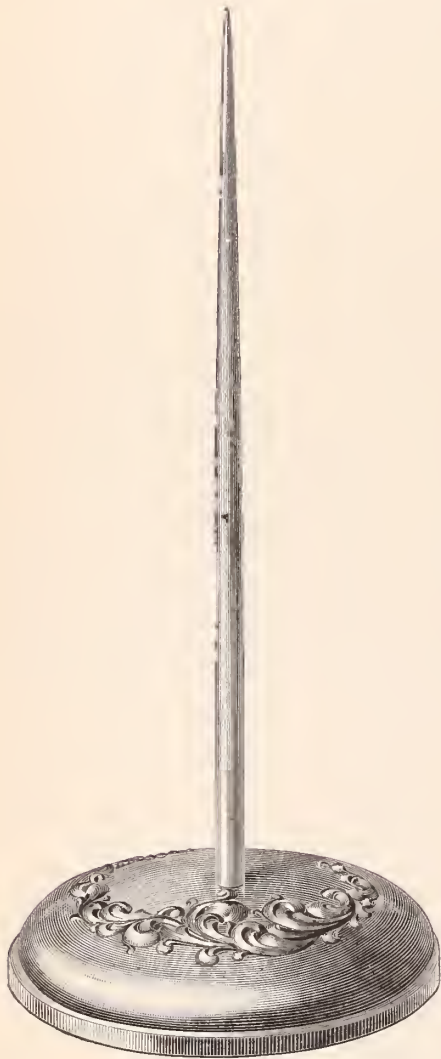

No. 10. PAPER FILE.

Trade Mark.

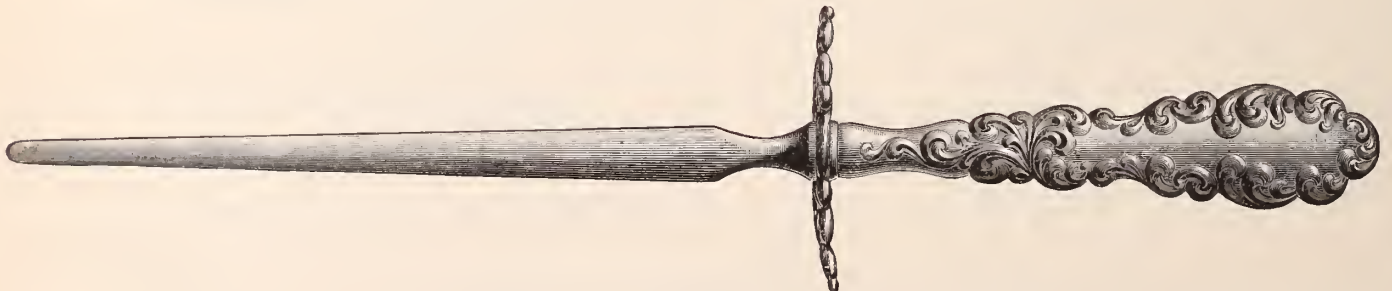

WAVERLEY MEDIUM PAPER KNIFE.

NEW YORK /  
226 FIFTH AVENUE.

SAN FRANCISCO  
120 SUTTER STREET.

CHICAGO  
86 WABASH AVENUE.

### The Larceny Case Against Gustav Berger Nolled.

MILWAUKEE, Wis., Nov. 29. — Gustav Berger, who was recently arrested at the instance of Adam Bloedel, the Grand Ave. jeweler, charged with having taken articles of jewelry and money amounting to quite a large sum while employed in the store, is once more free to continue his studies at a medical college in Chicago, his case having been nolled.

Berger was in Bloedel's employ for several years and had many friends in this city. When the case was nolled yesterday, Assistant District Attorney Thompson stated that he had made an examination of the case, and as it was the wish of Mr. Bloedel not to prosecute, he thought it best to have it discontinued.

### Diamonds Worth \$2,000 Slip Through a Hole in Sandman's Pocket.

PHILADELPHIA, PA., Nov. 26.—John T. Sandman, 737 South 2d St., had an unfortunate experience last Thursday. About noon he left his store carrying with him ten or fifteen diamond rings, valued at \$2,000, which he was bringing to a prospective purchaser in order to allow him the privilege of selection.

The rings were wrapped in tissue paper fastened with a rubber band. He put the package in a side pocket of his overcoat. On his way uptown to Library St., to meet

the purchaser he stopped at a South St. store to pay a bill, and afterwards visited a bank at 2d and Pine Sts., where he made a deposit. He then called at his house, 430 Pine St. He made several other calls and then stopped at the Continental Hotel for a short time.

When he got to Library St., he met a friend to whom he desired to show the rings. When he put his hand in his pocket the rings were gone; a hole in the pocket as well as in the lining of the coat explained the loss. The detective department has offered a reward, in Mr. Sandman's behalf, of \$300 for the recovery of the rings.

### Death of an Old Clock Maker.

BRISTOL, Conn., Nov. 28.—Andrew Ingraham died at his home on Peaceable St., Sunday afternoon, aged 87. He and his brother Elias who was the founder of the present E. Ingraham Co., were associated in the manufacture of clocks in Ansonia, Conn., in the '40s, but shortly afterward removed here.

He was identified, as stated with the first Ingraham partnership, and about 30 years ago the shop was burned. Mr. Ingraham continued to work at the business up to about 1887. He did this more on account of associations and his almost uncontrollable desire to have something to do, as he had means sufficient to retire to a quiet life free from care, long before he did.

### Hon. Amos J. Cummings Presented With a Solid Silver Punch Bowl.

BOSTON, Mass., Nov. 30.—A few months ago Congress passed a bill for the relief of the mates of the navy, by which they are now entitled to retirement upon three-quarters pay upon attaining the age limit of 62 years, or when found physically disqualified for active service. The pay of the mates was also increased one-third. The bill was passed mainly through the endeavors of Hon. Amos J. Cummings.

To show their appreciation of his services the mates have presented Mr. Cummings with a solid silver punch bowl and ladle of handsome design and artistic workmanship. It is about 15 inches in height, and the bowl is about a foot in diameter. It is in repoussé, beautifully figured with flowers and leaves. A monogram is engraved on the inside of the bowl and also on the handle of the ladle. The whole is enclosed in a suede leather case, in the top of which is secured a solid silver plate, bearing the inscription:

"Presented to the Hon. Amos J. Cummings by the mates of the United States Navy, in grateful recognition of his successful efforts in their behalf toward their deriving the benefits of the retired list, 1894."

A. J. Comrie, jewelers' auctioneer, on Dec. 4 commenced a reduction sale for E. P. Durando & Co., Chattanooga, Tenn. The sale for H. G. Booth, Rochester, N. Y., will be continued till Jan. 1, 1895, by Mr. Comrie's assistant.

## THE SOUL OF THE DIAMOND.

A PASTEL IN PROSE.

### I.



HUNDREDS of uncounted years it lies hidden from eye of man, enclosed in the baser mould in the bosom of Mother Earth, little dreaming that within its soul resides the quintessence of brilliancy and purity, and that man prizes it above all things of material value.



### II.

In the seeking for riches, after the prospector has discovered its lair, after organized labor has delved for it and unearthed it, from a nameless pebble it is a modicum of wealth, though in aspect but a dirty mite of quartz.

### III.

Traveling over the main, thousands of miles, it reaches the works of **OPPENHEIMER BROS. & VEITH, NEW YORK**, whose cutters and polishers lend their art, bringing forth its true nature and making it "a gem of purest ray serene," the superlative of beauty, the zenith of purity, emblem of riches, token of innocence.





# Perfect Construction

AND  
SUPERIOR FINISH

MAKE OUR PRODUCTIONS OF  
HIGHEST GRADE.

JEWELERS and  
FANCY GOODS DEALERS  
will find in our new line of

## Art Metal Goods

many articles specially adapted  
to their trade.



### The Finest Line of Banquet Lamps EVER PRODUCED.

Fitted with the Celebrated "B. & H." Burner.

New and Attractive Designs and Finishes. Sure to be Ready Sellers.

We will send you our Little Book, giving more information, if you desire,  
and will be glad to have you visit our Salesrooms and see the Goods.

## BRADLEY & HUBBARD MFG. CO.,

NEW YORK, PHILADELPHIA, BOSTON, CHICAGO,  
26 PARK PLACE 710 BETZ BLD'G. 160 CONGRESS ST. 204 MASONIC TEMPL.  
TO 21 BARCLAY ST. FACTORIES AND OFFICES, MERIDEN, CONN.

## W. F. Evans & Sons

SOHO CLOCK FACTORY,

HANDSWORTH,  
BIRMINGHAM,  
ENGLAND.

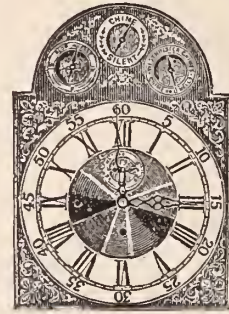

GRANDFATHER CLOCK.

Manufacturers of  
CHURCH,  
CHIME &  
QUARTER  
CLOCKS,  
SCHOOL AND  
HOUSE CLOCKS

With arch brass dials to chime upon  
Bells, Gongs, and Harrington's  
Patent Tubes.

ESTABLISHED 1805.

## J. R. WOOD & SONS, 14 JOHN STREET, NEW YORK.



MANUFACTURER  
OF



PLAIN SOLID GOLD RINGS.  
SEAMLESS PLAIN SOLID GOLD RINGS.  
ENGRAVED AND CHILD'S RINGS.

No Ring Stamped Different from Quality.  
Send for Catalogue and Price List.

Old Gold and Silver received and estimated on; if amount allowed  
does not give satisfaction, notify at once and will return at our ex-  
pense, in same condition as received.



## THE QUESTION

WILL IT TARNISH ?

not be asked if your Tissue Paper bears  
this label.

MANUFACTURED BY

## C. H. Dexter & Sons,

WINDSOR LOCKS, CONN.

◇ BE SURE YOU GET THIS BRAND ◇

It has been adopted and is now used by the leading  
manufacturers of this country.

IMPORTERS OF  
DIAMONDS.

JOBBERS IN  
Watches, Jewelry, Chains,  
NOVELTIES, ETC.

Latest Designs. Lowest Prices.

AIKIN-LAMBERT  
JEWELRY CO.,

19 Maiden Lane, New York.

CHICAGO BRANCH: 103 STATE ST.



### New York City to Become the Market of the Silver Smelters.

Daniel Guggenheim, of M. Guggenheim's Sons, 45 Cedar St., New York, who recently returned from a conference in Denver, Col., at which were represented all the large smelting interests of the country, in an interview with a reporter said: "We met simply for the purpose of investigating the practicability and advisability of the silver smelters and refiners disposing of their product through a central committee in New York. The silver product in the United States and that part of it in Mexico which is controlled by the United States amounts to 70,000,000 ounces a year. The entire product of the world ranges from 100,000,000 to 120,000,000 ounces a year. The price of our silver, despite the fact that we control the world's market for this commodity, is made in London.

"The committee appointed to investigate the advisability of arranging all sales through the central committee in New York consists of Guy C. Barton, A. R. Meyer and myself. Our object in bringing about the sale of silver in this manner is to eliminate the speculation in silver which is now being carried on by the brokers dealing in this commodity. In this way we hope to keep the price stable, and to be able at all times to tell just where we stand.

"If we are successful in carrying out our plans we will always have reliable information at hand concerning the supply and demand of the article. At the present time the only information we have on this subject comes from the brokers in England belonging to the silver ring.

"Another thing we hope to do is to market our own product. The big buyers of silver now are India, China and Japan. They buy our silver through London. There is no good reason why this should be so. We should sell to them direct."

"What result will the action of this conference have on the silver market?" Mr. Guggenheim was asked.

"When the business becomes thoroughly adjusted to the new conditions I believe there will be a slight advance in the price of silver. There will be no boom or sudden jump. It will simply be a gradual increase, such as the intelligent management of any business is likely to call forth."

### To Supply the Government With Silver Plated Ware.

WASHINGTON, D. C., Dec. 1.—The following awards have been made for furnishing the United States Quartermaster's Department, Philadelphia, Pa., with silver plated knives, forks and spoons:

John E. Frymier, Philadelphia, Pa., 184 dozen tea spoons, \$1.77½; 157 dozen table spoons, \$3.55; 72 dozen table forks, \$3.55.

Wm. Hodges & Co., Philadelphia, Pa., 236 dozen table knives, \$2.12.

Belt pins for the back of the 'dress' have made for themselves a substantial place.



(Enlarged fac-simile of head.)

# WAITE, THRESHER

# COMPANY,

# Providence, R. I.

OUR  
CANE  
Stick  
And  
Lapel  
Pins.

PATENTED  
OCT. 23, 1894  
ARE  
THE  
PROPER  
THING.

HEADS  
ARE OF  
SOLID  
GOLD OR  
STERLING  
SILVER,

Artistically  
CHASED.  
STICKS  
ARE  
ENAMELED  
TO  
REPRESENT  
NATURAL  
WOODS.

THEY SELL AT  
SIGHT.

# A MODEL FACTORY BUILDING.

THE KENT & STANLEY CO.'S MAMMOTH NEW STRUCTURE, THE FINEST OF ITS KIND IN THE WORLD.



**P**ROMINENT among the many handsome factory buildings for which Providence is noted is the handsome structure built and occupied by the Kent & Stanley Co., on the Square bounded by Sabin, Aborn, Beverly and Mason Sts., in that

city. The property which it occupies was the location of the old-time popular skating rink, destroyed by fire last year. Mr. Edwin F. Kent, recognizing the advantages of the site, on his own responsibility purchased the property after the fire, though at that time the building occupied by the Kent & Stanley Co., at Eddy and Fountain Sts., was generally looked upon as a model factory, excellently planned and perfectly equipped.

Mr. Kent's foresight in the matter of the purchase of the new site was soon endorsed by his partners. Its proximity to the new railroad depot, which will be one of, if indeed not the finest, in the country is a guarantee of increasing values in that section of the city, while the increased shop room was something rendered imperative by the firm's constantly increasing business.

Work on the new structure which is depicted in one of the illustrations in this article, was begun on November 1, 1893, and October 1, 1894, the company was operating in its new quarters.

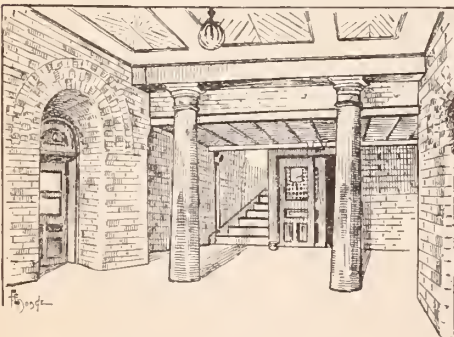

MAIN ENTRANCE ON SABIN ST.

The readers of the CIRCULAR can gather an idea of the immensity of the structure when it is borne in mind that it occupies an

acre of ground, rises seven stories above the foundation, has over 250,000 square feet of floor space, about 1,200 windows and required over five million bricks in its construction. While nearly all available space has already been leased, firms seeking modern quarters will do well to bear in mind that rentals are figured on a basis of 30 cents per square foot per annum, including power, steam heat water and elevator service.

The ground plan and character of the plot is excellently suited for the purpose to which it has been put. The L shaped formation gives it a frontage of 276 feet on Mason St., 221 feet on Aborn St., 106 feet on Sabin St., and 123 feet on Beverly St. A light well 40x200 feet extends from roof to basement in the main structure



THE KENT & STANLEY CO.'S BUILDING.

which with the additional advantage of four street frontages makes that great desideratum, good light, an assured fact for each tenant.

Red brick with brownstone trimmings was the material used for the walls, which rest on particularly solid foundations. At either corner on the Sabin St. facade are two handsome flag staffs held in place by artistic creations in wrought iron of dragons, one of which is incorporated in the initial letter beginning this article. Flags floating from these staffs bear, one, the company's trade mark on a white field and the other the national colors.

The two entrances to the building are well worthy of attention. Each shows a granite arch, while within enameled bricks of a light bluff tint please the eye and present an imperishable surface.

## THE KENT & STANLEY CO.

Our illustration shows the Sabin St. entrance with the handsome wrought iron elevator in the back ground, and two beautifully silvered supporting columns. The other entrance on Beverly St. is practically the same. Marble slabs for the names of the tenants is another feature not usually found in a factory building, and rapid running passenger elevators at either entrance afford quick access to, or egress from any floor. In the driveway running through from Sabin to Mason Sts., are two commodious freight elevators.

Floorings throughout are of maple, each floor being nearly an acre in area. The supporting columns are of iron, rising thirteen feet to the ceilings. Grinnell sprinklers and all other modern factory conveniences make the building a perfect one, whether from the view of the tenant, the insurance or the factory inspectors. Over 3,500 hands can find accommodation within its walls. Power and light are furnished by the company's private electric plant, one of the finest in the country.

The offices of the Kent & Stanley Co. are fitted up in oak, in the best taste, and pre-

sent an exceedingly attractive and handsome appearance. They occupy practically the whole of the Sabin St. wing on the sixth floor. Our illustration shows a view of the general office; adjoining it is the private office of Mr. E. F. Kent, which also connects with the director's suite.

The Kent & Stanley Co.'s shop, ever known as a model one, is in the new building better than ever. In one of the illustrations accompanying this article is shown a corner in the silver shop, a line in which the company is winning rapid recognition, and of which some of the productions, notably yachting trophies, have already been the subject of extended mention in the CIRCULAR.

A pioneer in selling its goods directly to the retail trade, the company, through its ten traveling salesmen and New York, Boston, Philadelphia and San Francisco offices offers a wide and varied line of goods. Some idea of its scope can be gathered from the fact that among them are:

## THE KENT &amp; STANLEY CO.

One-tenth and one-quarter Gold Seamless Wire Chains; Gents' Rolled Plate Vests, all Seamless Wire, 1, 2, 3, Strand Curbs; Dickens, Trace, Rope, Single Curb, Boston



VIEW OF GENERAL OFFICE.

and Fancy Links; Red Gold and Platinum Links in all styles; Ladies' Lorgnette, Neck, Vest and Victoria Chains; 1,500 styles Gold, Silver and Plated Locketts and charms; White Stone Lace Pins and Brooches; Hair Ornaments; Chain Bracelets, Plate and Sterling Silver; Hat, Hair, Stick, Scarf and Bib Pins; Plated Sword Corsage Pins; Bracelet and Eye-Glass Chains.

In Sterling Silver Novelties, all warranted Sterling Silver are: Garters, Collarettes, Pocket Combs. Tie Holders; Belts with Silver, Pearl and Tortoise Shell Buckles, Paper Cutters and Weights, Match and Stamp Boxes, Trays, Letter Clips, Letter Openers, Book Marks, Prayer Book Marks, Thermometers and Calendars, Satchel Tags, Hat Marks, Coat Hangers, Souvenir Spoons, Umbrella Clasps, Pearl Teething Rings and Rattles, Glove Hooks, Button Hooks, Glove Stretchers, and Hat Buckles, Hair Pins in Celluloid, Real Tortoise Shell, Silver Mounted; Tooth Brushes, Shoe Horns and Letter Seals, Mirrors, Game Counters, Cigarette Cases, Sword Corsage Pins, Key Ring Chains, Bonbon Spoons, Pocket Knives, Scissors, Razors, Manicure Articles, Gold and Silver Mounted Suspenders, Novelties in Leather Card Cases, Memorandum Books, etc.; Stag Handle Cutlery Novelties, Corkscrews and many others.

The company issued last year one of the finest illustrated catalogues ever put out by a jewelry house and another is now in preparation which will be even better than

## THE KENT &amp; STANLEY CO.

its predecessor, if that is possible. The business of the present Kent & Stanley Co. was first established in 1873 under the style of William H. Robinson & Co.,

at 25 Calendar St. and the output consisted of chains. In 1882 Mr. Edwin F. Kent became a member of the firm and at once took an active interest in its welfare. In 1884 occurred the disastrous fire still remembered by the citizens of Providence, in

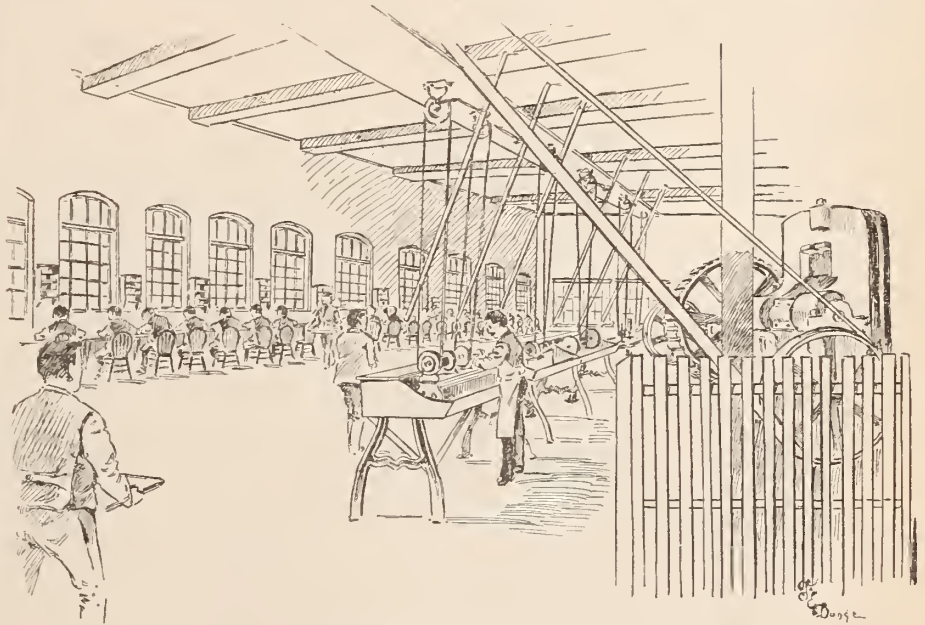

A CORNER IN THE SILVER SHOP.

which the factory was destroyed. New quarters were found at 7 Eddy St., and operations were again resumed. In 1885 Mr. Robinson died, and for nearly two years the business was conducted by the

## THE KENT &amp; STANLEY CO.

surviving partners, Edwin F. Kent and Arthur W. Stanley, under the old firm name. In 1887 these gentlemen purchased Mrs. Robinson's interest and continued under the style of Kent & Stanley. Under the new impetus, business during the two following years was doubled, but on Feb. 19, 1888, another fire once more interrupted operations by burning the factory entirely to the ground. Another shop was immediately found by Mr. Kent, and by noon of the day following the fire new machinery was already being put in position at the new shop, an instance of his indomitable will and prompt action in an emergency to which is due in a large measure the firm's success and high position to-day.

A lease of the ground on which the burned building had stood was quickly secured, and without the least unnecessary delay, Kent & Stanley began the erection of a building suitable to the needs of jewelry manufacturers which, when completed, ranked among the best factory buildings in the city. The firm took up its quarters in it and continued with increasing success. In February 1891, it was incorporated, under the title of the Kent & Stanley Co., being capitalized at \$300,000, represented in real property, and with charter rights for half a million. In November, 1893, the constantly increasing business necessitated larger quarters and the balance of the treasury stock was issued. In July, 1894, this additional stock had been issued, paid for in cash and invested in the new plant, which forms the subject of this article. It represents an investment of about \$350,000, and the total capital and surplus of the company in-

vested in business is \$650,000. Its officers are: president, A. W. Stanley; treasurer, E. F. Kent; vice-president, J. S. Ingalls; secretary, J. D. Warren. George R. Clarke is superintendent and designer.

### R. J. F. Roehm's 45th Anniversary as a Jeweler.

DETROIT, Mich., Dec. 1.—Forty-five years ago, Dec. 5th, in 1849, R. J. F. Roehm hired out as an apprentice to A. Valentine, who was then the leading jeweler in Detroit.



R. J. F. ROEHM.

Since that time Mr. Roehm has been engaged continuously in the business although he has made many changes in the location and scope of his store.

After serving with Mr. Valentine for several years he went to Providence, R. I., where he perfected himself in the details of his chosen profession. Returning to this city in 1862, Mr. Roehm entered the store of George Doty, but shortly afterward started a small shop on his own account

over M. S. Smith's store. Several years later saw an improvement in his condition, and he opened on Gratiot Ave. on a somewhat larger scale, where he remained until 1870. At that time Detroit was booming and he determined to rise with it, so he opened up on still more generous lines at the corner of the Campus Martius and Woodward Ave. At this place he was the first one to place a plate glass in his front window which was a decided novelty and made a hit.

Mr. Roehm was a pioneer in one respect, for he believed that the trend of business was away from the river front. Many of his friends and competitors exclaimed that he was too far up town, but the result has shown that he exercised good judgment. For 16 years he prospered here, when he moved still further up town to his present location at the corner of Woodward Ave. and Grand Circus Park. At that time there was not a jewelry establishment within three blocks of him. Within the last two years three others have moved up and into line. This part of the city is bound to become the shopping center in a few years, if it is not so already. F. G. Smith & Sons will shortly occupy new quarters within a block of the Roehm store.

The present Roehm establishment occupies three large floors, one of which is given up to manufacturing. Diamond work of all descriptions is done here and original designing furnished. Mr. Roehm is a dia-

mond expert and appears never to be so contented as when he is sitting at his bench with his coat off presiding over some unique and original piece of work. The jewelry store proper is a pleasant room filled with a costly and well selected stock of gems, pottery and artistic ornaments of all descriptions.

When he first started in the business, Louis and William Hall, M. S. Smith, Charles Piquette and George Doty were the leading jewelers. All have long since retired and some are dead. The business was run on a much smaller scale than now. Doty employed one watchmaker, two salesmen, one repairer and one bookkeeper. Mr. Roehm at present has 25 men on his pay roll. Three times as much stock is carried now as in olden days, and the average valuation of the stocks of the leading jewelers here is \$100,000. They have become art emporiums, of which Mr. Roehm's store is one of the most artistic. Of late years the harder part of the business has fallen on the shoulders of his son, Edwin, but he is still the life of the concern. He is nearly 60 years old.

In the case of the Rockford Watch Co. vs. Simon Rumpf, Seattle, Wash., an order citing the First National Bank to make a return as to goods belonging to J. K. Basye & Co. in its possession was vacated by stipulation.

# STERN BROS. & CO.,

Cor. John and Nassau Streets, = = = NEW YORK.

CUTTING WORKS: 29 & 31 Gold St.

LONDON OFFICE: 29 Ely Place.

## Our Diamond Cutting Works

were established two years ago, and this was the first attempt to cut diamonds on an extensive scale in the United States.

## Our Factory

is to-day the largest and most complete of its kind in this country and rivals the best equipped establishments in Europe.

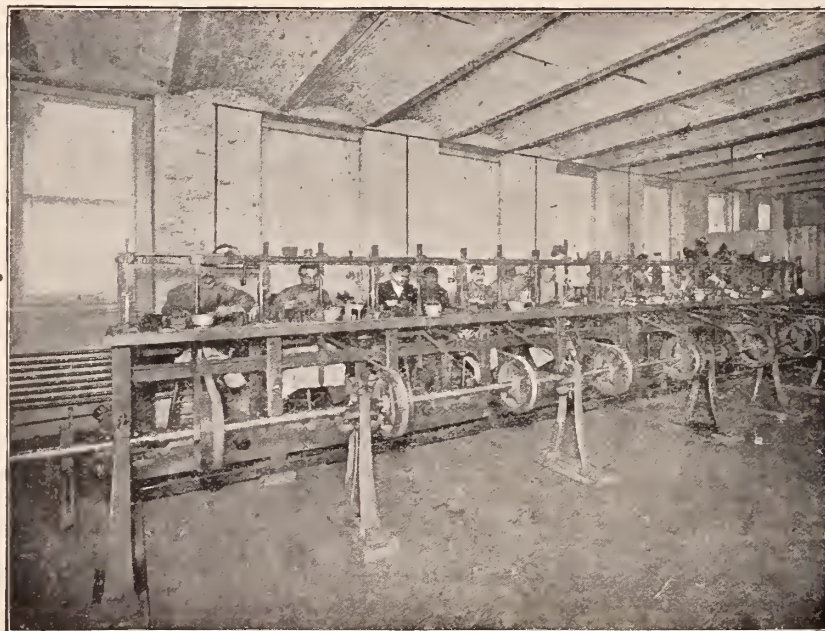

PART OF EAST WING ON THE MIDDLE FLOOR.

## Our Workmen Are All Skilled Artisans,

having had years of experience in their respective departments.

For finish and cut our goods bear the closest scrutiny of the most critical buyer.

## These Statements are Absolute Facts

and not used for the mere purpose of advertisement.



# YOUR HOLIDAY TRADE

.. WILL REQUIRE ..

## Muff Holders.

**WE HAVE THEM!**

Prices range from \$12 to \$20 per dozen. All complete. Sterling Silver Mountings, Satin Ribbons, stylish and taking.

OUR LINE OF

**QUICK SELLING NOVELTIES**

INCLUDES

**CZARINAS, BELTS,  
GARTERS, SUSPENDERS,  
BON BON SPOONS, Etc.**

All in Sterling Silver. Write us!

**CODDING BROS. & HEILBORN,  
NORTH ATTLEBORO, MASS.**

NEW YORK OFFICE, CHICAGO OFFICE,  
C. A. Vanderbilt, 178 Broadway. F. A. Buck, 103 State St.

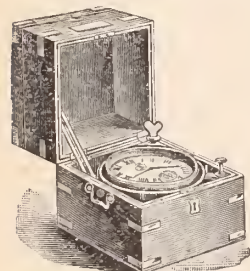

## MARINE CHRONOMETERS,

MANUFACTURED BY

**John Bliss & Co., 129 Front St., New York.**

We have on hand a number of Chronometers, by various good makers, not new, which have been in service for purposes of navigation, and are excellent instruments. They have been put in perfect repair and will give satisfactory results as to performance. We will sell these Chronometers at low prices, either for cash, or on accommodating terms to suit special cases, or will hire them at moderate rates and allow the hire to apply on purchase.

SEND FOR CIRCULAR GIVING PRICES AND TERMS.

## VACHERON & CONSTANTIN, GENEVA, SWITZERLAND.



FINEST QUALITY OF WATCH MOVEMENTS, FITTING ALL SIZES OF AMERICAN CASES.



**EDMOND E. ROBERT,**

Agent for the United States and Canada

21 & 23 MAIDEN LANE.

NEW YORK.

Sold by all wholesale dealers at manufacturer's price.

**A. N. CLARK & SON  
PLAINVILLE  
CONN.**

Manufacturer of the Celebrated  
**LOOP WATCH KEY.**

The Best for the Price in the World.  
CROSBY'S JEWELING TOOLS IMPROVED.

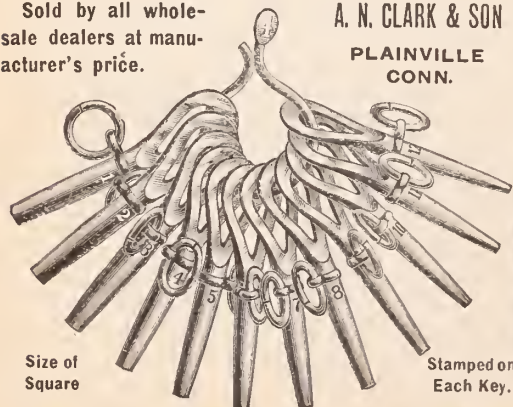

Size of Square

Stamped on Each Key.

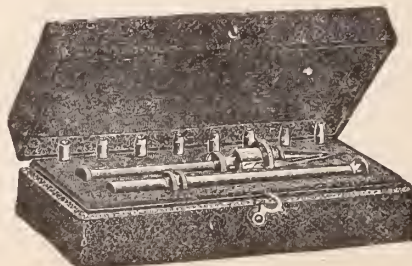

Will quote royalty or price for the manufacturing of articles of real worth.

### An Ingenious Scheme to Rob Smith & Patterson Frustrated.

BOSTON, Mass., Nov. 30.—Smith & Patterson have had a narrow escape and are looking after their diamonds with unwonted care since they made this discovery.

This morning, when the clerk having the diamond window display in charge was about to set the brilliants in their accustomed place, he noticed traces of sawdust on the velvet covering that usually forms a groundwork on which the gems are placed. This led to an investigation, and the discovery followed of two auger-holes bored through the window frame and carefully plugged with inked cork, matching the framework in color and fitting into the aperture so nicely that it was almost a wonder that the job was detected even when special search for something wrong was made. The ink was moist and fresh on the corks and the scheme had evidently been carried out as far as the preliminaries were concerned in the small hours of this morning.

To understand the situation more completely it is necessary to state that the window has been screened with iron barring ever since the window breaking epidemic made its appearance in Boston. But the firm are in the habit of putting a fine display in this particular window and it was a tempting lay-out. The first hole bored was presumably unsatisfactory, for it came out too high to clear the screening. The second was just right for the thieves' purpose, however.

It was evident that a hold daylight operation had been determined upon, for the diamonds are removed to the safes at night. From \$15,000 to \$20,000 is the value of the stock set in the window most of the time, the firm usually making as fine a display as any house in the city. The scheme evidently was to remove the cork and, while one thief kept guard, the other, if opportunity presented, could remove the cork, run a wire with a hook on the end through the auger hole and secure ring after ring and pins or other settings in very quick time. The police pronounce it the most ingenious scheme they have ever met with in the jewelry robbery line.

### A Shrewd Gang of Jewelry Store Thieves Located.

MONTREAL, Can., Dec. 1.—One of the shrewdest gangs of diamond swindlers in the United States was located in this city yesterday afternoon in a fashionable house on Mansfield St. For several months the police in several large American cities have been looking for this gang, including the detectives of Boston and Cleveland, in which places the members of the gang have been carrying on their operations. In the former place they succeeded in swindling two large jewelry establishments out of \$8,000 and three diamond firms in the latter place out of similar amounts. Two weeks ago the gang, which is composed of three women and two men, finding that it was getting too hot for them on the other

# ★ ROGERS & BRO., A I.

## ORANGE SEASON....

### ORANGE KNIVES.



Pearl, Ivoride or Plated Handles,  
Cutting Edge, Saw Back Blades.  
*(A feature first introduced by us),* making  
a good all round Fruit Knife.

### ORANGE SPOONS.

FLEMISH

COLUMBIA

SAVOY

TUXEDO

HARVARD

YALE

PRINCETON

STOCKBRIDGE

FLORIDA

SHELL

PATTERNS.

Put up in sets of 6 in Plush Lined Boxes.

### ORANGE SETS.

1 Knife and 1 Spoon, or  
6 Knives and 6 Spoons.  
Put up in Plush Lined Boxes.

### ORANGE PEELERS.

..... POCKET OR TABLE SIZES.

### ORANGE HOLDERS.

Also a Large Line of Fancy Pieces put up in Beautiful  
Plush Lined Boxes. Suitable for the Holiday Trade.

FLEMISH ORANGE SET, No. 5.



# ROGERS & BROTHER,

16 Cortlandt St., New York.  
WATERBURY, CONN.

THE OLDEST MANUFACTURERS OF ROGERS' GOODS IN EXISTENCE.

side of the line, moved their scene of operation to Canadian soil.

After getting comfortably ensconced in luxurious apartments on Mansfield street, they "took in" the various jewelry establishments in the city and then laid a carefully prepared plan for swindling the leading jewelers in this city out of diamonds and valuable stones. The first establishment visited was that of Richard Hemsley, St. James St. Here they were successful in substituting a paste diamond for a 2 karat stone of the finest water. On Thursday last Mr. Cochen-thaler's establishment on the same street was visited and as in the former case paste diamonds were left in the sample tray and real stones taken. So cleverly were the exchanges made that the swindlers had been gone some hours before the robberies were discovered.

It is supposed that the parties wanted belonged to a gang whose representatives have already made their mark in Montreal some months ago when they attempted to sell, through the aid of a well-known St. Catherine St. jeweler, a large quantity of cut diamonds and other jewelry. While this jewelry was for sale the dealer had occasion to go to New York, and was nearly trapped into smuggling, unknown to himself, thousands of dollars' worth of valuable laces into this country. Fortunately in New York he was put on his guard about the supposed owners of the jewelry, and

the latter shortly after took back their jewelry and left the Windsor, where they were boarding, presumably to go to England.

No arrests have yet been made.

#### Braverman & Bostelman Go to the Wall.

A special dispatch, received Saturday, stated that Braverman & Bostelman, diamond importers, San Francisco, Cal., with an office at 14 John St., New York were reported failed. The liabilities, it said, are \$44,000 in San Francisco and \$38,000 in the east, while the assets were not known. The indebtedness in San Francisco, it was reported, was for money and was secured. Another dispatch stated that Mr. Braverman had given a preference to his father.

The firm was formed in January, 1893, by Sigmund L. Braverman, of San Francisco, and Rudolph W. Bostelman, New York. At the office of the firm, 14 John St., the father of Mr. Bostelman was seen by a CIRCULAR reporter Saturday. He said the firm had been pressed by eastern creditors, but in a few weeks they would come out all right. The largest creditors, the father said, in New York were two for about \$6,000 and \$2,000. The elder Bostelman stated that he was only an employe and had been in charge of the New York office. From a letter he had just received from his son he believed that the embarrassment was only temporary and that the firm would resume business in about a month. He also said that none of the

creditors would lose a cent. There was neither stock nor fixtures in the office when the reporter called.

#### Joseph Rundbach Makes a General Assignment.

Joseph Rundbach, retail jeweler, 2168 Third Ave., New York, made a general assignment Wednesday without preferences, to Steven G. Patterson, 207 Congress St., Brooklyn. The day before Deputy Sheriff Mulvaney received two attachments against J. Rundbach, which were obtained by Franklin Bien for L. Tannenbaum & Co., \$1,862 for diamonds, and for Morris Kollender, \$606. Mr. Rundbach, it was alleged, had gone to Hartford, Conn. As told in THE CIRCULAR last week he had given a bill of sale on the 23d inst. to Amelia Rundbach for \$1,000.

A CIRCULAR reporter was unable to see Mr. Rundbach or his assignee, but at the office of Campbell & Murphy, the attorneys for both assignor and assignee, the reporter was told that the attachments had not been the cause of the assignment as the latter step had been contemplated for some time. The liabilities it was stated were about \$10,000, and the assets about \$8,000.

"If the attachments are vacated," said the reporter's informant, "and we expect they will be Monday, we will file our schedules within three days after we take possession." "No," he said, "Mr. Rundbach has no idea of calling a meeting of his creditors as yet. His indebtedness is practically all in this city."

Mr. Rundbach, who was originally a manufacturer of a cheap grade of children's rings at 80 Nassau St., started in the retail business about eight years ago. About a year ago he opened a branch store in 125th St., which was later closed out. His failure was not unexpected.

#### The Store of Charles E. Burnham Burglarized.

WHITE PLAINS, N. Y., Nov. 28.—The jewelry store of Charles E. Burnham, was entered Saturday night by thieves, and silverware and jewelry worth \$1,000 stolen. No attempt was made to open the safe, in which Mr. Burnham had placed valuable watches, pins, bracelets, etc. Chief of Police Bogart has no clew to the thieves.

The thieves gained an entrance through a rear window to which they climbed by means of a ladder. The glass was first covered with sheets of fly paper, then cut with a diamond and pushed in. The thieves took about 150 pairs of gold-rimmed eyeglasses, thirty watches, and some silverware. It is believed that the burglars have been in town for a week and are responsible for several attempted burglaries on private residences that occurred during that time.

F. Lewald & Co., of Chicago, have incorporated; capital stock, \$75,000; incorporators, Frank Lewald, Albert H. Leob and Sidney Adler.

# WE LEAD



## IN Royal Worcester.

### We Are Offering To-Day

Lines of shapes and decorations intended by the Royal Worcester Porcelain Company for next spring. We can sell you OUT OF STOCK goods which will be shown as novelties in February by other houses.

# LE BOUTILLIER & Co.,

860 BROADWAY,  
NEW YORK.

Northeast Corner of Seventeenth Street



**Assignment of Max Hammelrath.**

CINCINNATI, O., Dec. 3.—Max Hammelrath has made an assignment to William Creed.

The assets are \$10,000 and the liabilities \$8,000.

**The Silversmiths' Company Reduce Their Capital Stock.**

ALBANY, N. Y., Nov. 28, 1894.—A certificate of the reduction of the capital stock of the Silversmith's Company from \$12,000,000 to \$100,000 has been filed with the Secretary of State.

The amount of the capital which had been paid in was only \$8,500, and the company are without debt or liability. The company had thirteen directors and reduced the number to three.

**The Mass. Retail Jewelers' Association to Hold an Important Meeting.**

The following call has been sent out by W. W. Newcomb, secretary of the Massachusetts Retail Jewelers' Association:

FITCHBURG, Mass., Dec. 1, 1894.

MY DEAR SIR—We feel there is no subject more

vital to you than that contained in this circular. A large number of the craft of this State felt so a few days ago, when they assembled at Worcester in larger numbers than was ever known before, and after listening to an address by Arthur S. Goodman, organized with the above named officers.

Now it is proposed holding in the Board of Trade rooms, Worcester, Mass., another meeting Jan. 3, 1895, at two o'clock sharp, to discuss and map out the work of the Association.

Nothing, save the most serious duties should prevent your attendance at this meeting. We want to know just what the abuses are you have to contend with, in order that we can get to work and assist you in correcting them. Besides, we want the advice of every one of the craft, in order that from a multiplicity of opinions, the best may be had, to guide us in our work of correcting trade abuses. There are men in this State who have felt in their business the heavy hand of trade abuses, and these men are willing to work, not only for their own, but the cause of every craftsman in this State. In such a case, who is the man who will not assist?

The largest watch companies confess their inability to control the channels through which their products shall be sold.

The big silverware manufacturers are in the same boat. Clocks and jewelry are sold by about every dry goods store and corner grocery, and hawked about in every town and city in the country. What are we as retail jewelers going to do about it? These are some of the questions we shall assemble to talk over, these and many other important matters will require our most thoughtful consideration, they are problems no one man or one organization can cope with alone.

Come and let us reason together.

It is with pleasure that we announce the fact that our association has made a very successful beginning towards bettering the conditions of the jewelry trade. Every wide-awake jeweler of the Old Bay State should take active part in the demonstrations now on for the better protection of the trade

Mr. ARTHUR S. GOODMAN, president of the National Association, will be present and address the organization. No one is better qualified to speak on trade subjects, enjoying, as he does, a wide experience both as a practical retail jeweler and as president of the Pennsylvania Association for the past five years.

The National Association now comprises Pennsylvania, Ohio, Missouri, Illinois, Alabama, Mississippi, New York, Iowa, Kansas, Wisconsin and Massachusetts.

Lay aside a half-day of work and attend this meeting. We are confident that you will never regret it.

Fraternally yours,

R. C. ELDRIDGE, *President*,  
Milford.

F. E. LADD, *Vice President*,  
Springfield.

W. W. NEWCOMB, *Secretary*,  
Fitchburg.

Chas. H. Haner, Richmond, Ind., is in New York city on business.

The jewelry store of G. B. Evans, Kendalls, Wis., was entered last week and about \$150 worth of jewelry taken. There is no clue to the perpetrators.

DIAMONDS.

ESTABLISHED 1877.

WATCHES.

OUR PRICES WILL GIVE YOU A WIDE MARGIN OF PROFIT.

THE STEIN & ELLBOGEN CO.

A COMPLETE STOCK TO SELECT FROM IN LATEST DESIGNS. IT WILL

BE TO YOUR BENEFIT TO ADDRESS US BEFORE

PLACING FALL ORDERS.

JEWELRY.

COLUMBUS MEMORIAL BLDG., CHICAGO.

CLOCKS, &C.

ARE YOU PUSHING THE SALE OF

TRENTON MOVEMENTS?

IF NOT, WHY NOT?

For intrinsic value and great merits combined, with LOWNESS of PRICE, they far surpass any movements ever placed on the market.

A sample line will thoroughly convince you that it will be to your advantage to handle them extensively.



6 SIZE, 7 JEWELS.



16 SIZE, 16 JEWELS.

INSIST UPON HAVING THEM.

TRENTON WATCH CO.,

TRENTON, N. J.

## EXPANSION OF THE DIAMOND CUTTING INDUSTRY IN AMERICA.

## PART II.

*Commenced in Issue of Nov. 21, 1894.*

THE illustration here shows a portion of the diamond cutting and polishing establishment of Arnstein Bros. & Co., at 45 John St., New York. It represents the new quarters of the firm. This enterprising house have almost doubled their capacity, the latest addition being a new line of

ally the same as fully described in the chapter in the previous instalment of this series of articles, relating to a complete diamond cutting and polishing plant.

Arnstein Bros. & Co. have been in existence as a firm of importers of diamonds almost ten years, having started in 1886.

employment to 50 hands, which force will be increased as the demands require. The firm's office is at 37 Maiden Lane.

## L. TANNENBAUM &amp; CO.'S WORKS.

The new diamond cutting and polishing works of L. Tannenbaum & Co., New York, are fitted up with machinery of the latest and most improved pattern. The polishing mills are provided with all the latest and most approved attachments. The shop also has hand-power cutting arrangements, and facilities for scouring and balancing the polishing wheels.

Mr. Tannenbaum prefers to let his work and prices speak for themselves. He holds enormous quantities of rough, imported duty free, and the price at which he offers the finished stones finds for them ready purchasers.

## THE STEIN &amp; ELLBOGEN CO.'S WORKS.

The factory of the Stein & Ellbogen Co., Chicago, was established two years ago as the firm believed they could successfully compete in cutting diamonds in this city against the European market with the then existing tariff and especially so on fine goods. A small factory was at that time thought sufficient for several years to come and space was provided in the wholesale jewelry salesrooms by building a half floor or balcony at the east end of the salesroom. The reputation of their diamond cutting plant quickly spread and the factory outgrew its allotted space and within eighteen months the firm found it necessary to remove the diamond cutting works to larger quarters, which were secured on the 14th floor of the Columbus building, the handsome wholesale rooms of the firm remaining on the fourth floor.

In their new quarters the latest improved machinery was added giving them the largest and most complete diamond cutting

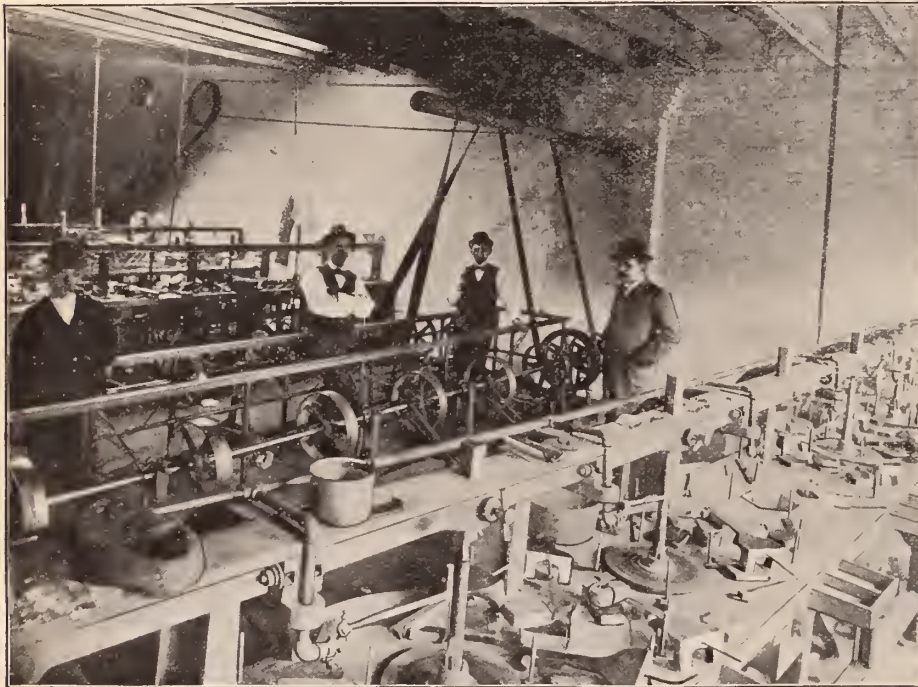

VIEW OF THE DIAMOND WORKS OF ARNSTEIN BROS. & CO.

Arthur improved mills. The machinery is driven by a C. & C. electric motor. The power is carried from this to two overhead "jack shafts," each of which drives two floor line shafts. Each of the latter in turn drives its row of mills.

The other details of the shop are gener-

During this time they have established a high reputation in the trade and are well and favorably known throughout the country. They have been cutting diamonds since early in the year and it is their aim to produce well cut goods at the lowest possible prices. At present the plant gives

DIAMOND CUTTERS and POLISHERS looking for desirable and permanent positions should apply direct to

**FOX BROS. & CO.,**

68 and 70 West 4th Street,

CINCINNATI, OHIO.

plant in the west. The new factory is thoroughly equipped and the workmen were selected for their special ability in this

full year before the tariff agitation gave further incentive to the diamond cutting business. Its success from the commence-

Bert Edmunds, formerly with Jenkins & Co., jewelers, Richmond, Ind., who spent the Summer on a California fruit farm for

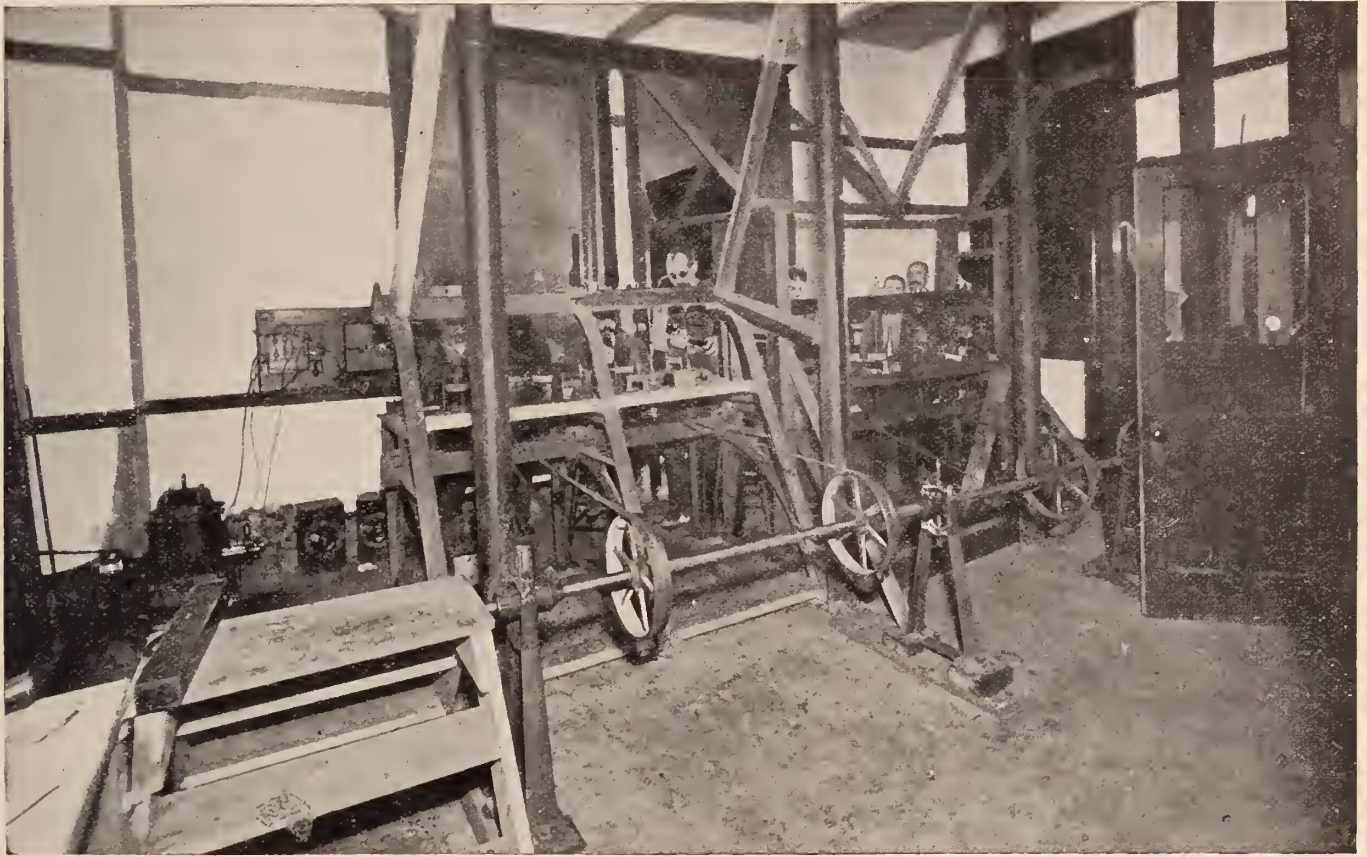

VIEW OF THE DIAMOND CUTTING WORKS OF THE STEIN & ELLBOGEN CO.

particular line. Mr. Koetser, a man of tried experience, has charge of the factory as cleaver and superintends the work of the polishers. The factory was in operation a

ment has been marked and continuous and reflects credit upon the enterprise of its founders.

*(Series to be continued.)*

the benefit of his health is now employed in a large jewelry store of San Francisco. His health was perfectly restored while working on the fruit ranch.

**THE ARTHUR CO.,** LEADING DESIGNERS AND BUILDERS OF  
**DIAMOND MACHINERY** IN THE UNITED STATES.  
Machine Works, 86 John Street and 188-190 Front Street, NEW YORK.

# ARNSTEIN BROS. & Co.,

IMPORTERS AND

**DIAMONDS**

CUTTERS OF

CUTTING WORKS,  
45 JOHN STREET.

**37 MAIDEN LANE, N. Y.**

**The Brace of Thieves Who Robbed Jos. K. Davison Captured.**

PHILADELPHIA, Pa., Nov. 30.—Detectives Crawford and Geyer made a lightning all-round trip to New York and back provided with a requisition from Governor Pattison, and returned with the handcuffs on two alleged expert New York jewelry thieves, Alfred Bratton, alias "Toothpicks," aged 32 years, and Frank Seaber, alias "Sawyer," 29 years old.

The Philadelphia authorities have had a struggle for over a month to get possession of the alleged thieves, on the charge of the larceny of 23 unset diamonds valued at \$350, the property of Joseph K. Davison, 718 Sansom St. The two men were arrested

in New York on another local charge of larceny of jewelry, and were only tried and acquitted this week. They were then turned over to the Philadelphia detectives, and were whisked away to this city.

On Sept. 27th two well dressed men entered Mr. Davison's store and asked to be shown some diamonds. A clerk waited upon them. The spokesman desired a jewel that would be appropriate for his wife to wear in a ring. He selected a stone worth \$60, asking that it be laid aside until afternoon, when his wife would call. The smooth spoken man did return with a well dressed woman, and the latter cast her eyes over a tray of diamonds, which, besides loose stones, contained several

packages of gems wrapped in tissue paper. After a short inspection the woman said she was not satisfied, and abruptly departed, followed by her confederate. They had gone only a few seconds before the clerk discovered the theft of one of the packages.

**Details of the Assignment of D. G. Gallett.**

ABERDEEN, S. Dak., Nov. 30.—The assignee of D. G. Gallett is Ira Barnes. The liabilities are understood to be in the neighborhood of \$4,000, with assets fully ample to cover the amount. The hard times coming on unexpectedly caught Mr. Gallett with a larger stock of goods on hand than his reduced trade warranted, hence bills became due without the cash being on hand with which to meet them.

Nearly all of the creditors, it is understood, were willing to grant further time, but a few proved intractable, unwilling to grant the smallest accommodation, so there was nothing left for Mr. Gallett to do as an honorable business man except to make an assignment, so that all creditors would share alike.

Mr. Gallett has been in business in this city since the Summer of 1883 and has always borne a good name and business reputation.

**L. H. Goldsoll Again Before the Authorities.**

CLEVELAND, O., Nov. 30.—L. H. Goldsoll, who conducts an alleged jewelry store on Superior St., and who is under indictment for connection with the Orange Fruit and Stock Farm lottery swindle, is again in trouble. Mrs. Frances Stephens caused his arrest, Wednesday, charging him with obtaining money under false pretenses.

The lady alleges that she desired to purchase a watch chain, and went into the store of Goldsoll, where she priced goods. A chain that suited her fancy was represented to be solid gold filled and warranted to wear 20 years. She took the chain, paying \$10 for it, and at the same time received a receipt for the money and a written guarantee. Upon investigation she found that chains of the same kind were being sold by other dealers for from 98 cents up to \$1.

Henry C. Haskell, 11 John St., New York, has issued to the trade a unique folding card which will prove effective as it calls attention to and illustrates many of his popular novelties. The outside is in red and yellow in representation of an old fashioned document.

**DIAMONDS.**

**Wm. S. Hedges & Co.,**

Importers of Diamonds,

And Manufacturers of DIAMOND JEWELRY.

170 Broadway, New York.

22 Holborn Viaduct, London.

**Alfred H. Smith & Co.,**

IMPORTERS

**DIAMONDS**

AND

**PRECIOUS STONES,**

82 BROADWAY, COR. JOHN STREET,

NEW YORK.

83 Holborn Viaduct, London, E. C.

**R. A. KIPLING,**

Precious Stones

AND Fancy Goods

Bought and Sold on Commission.

19 RUE DROUOT,

PARIS, FRANCE.

**2 MEDALS AWARDED**



Providence Shell Works, Providence, R. I. Correspondence Invited.

**FERD. FUCHS & BROS.**

**SILVERSMITHS,**

MAKERS OF STERLING SILVERWARE,

808-810 Greenwich St., New York.

**KELLER, ETTINGER & FINK,**

SELECTION ORDERS SOLICITED.

24 JOHN STREET, NEW YORK.

DEALERS IN

MOUNTERS OF

IMPORTERS OF

American Watches.

Fine Diamond Jewelry.

Diamonds.

**New York Importers Still Desire the Old Duties on Diamonds.**

The following letter appeared in the New York *Herald* of Nov. 28:

To the Editor of the *Herald*:

Before the new tariff on diamonds went into operation, importations under the old tariff had been so largely made by importers that the New York market was well supplied for the holiday trade, and the public are this year having the benefit of diamonds at the old prices. Since the new tariff has gone into operation the importations have been so small that its effect is not yet felt.

Prior to the late war the duty on diamonds was 5 per cent. but in 1864 it was raised to 10 per cent as a war measure, and was the highest ever known until the recent change to 25 per cent. by a great mistake of our present Congress. Since 1864 the several committees and the United States Treasury Department have always concurred in recommending the rate of 10 per cent. not only as yielding the largest amount that could be collected by the government, but also as affording the greatest protection to the honest dealer.

Precious stones are not an extravagance or a luxury in the strict meaning of these terms, because, by reason of their imperishable nature, they add to the wealth of the country, and every nation except the United States recognizes this approach of diamonds to a bullion value, and, treating them as lasting and imperishable wealth, has refrained from imposing duties upon them.

The ten per cent. duty, which can be fully collected, was favored by the members of the Ways and Means Committee of the present Congress, but the populists, being desirous of putting themselves on record before their constituents, succeeded in carrying the present high rate.

TIFFANY & CO.  
 RANDEL, BAREMORE & BILLINGS.  
 ALFRED H. SMITH & CO.  
 L. & M. KAHN & CO.  
 WM. S. HEDGES & CO., per Jeanne.  
 HODENPYL & SONS.  
 EISENMANN BROS.  
 JOSEPH FRANKEL'S SONS.

New York, Nov. 24, 1894.

**The Creditors of Joseph Rundbach Hold a Meeting.**

A meeting of the creditors of Joseph Rundbach, New York, whose failure is announced in another column, was held at the rooms of the New York Jewelers' Board of Trade, in the Sheldon building, John and Nassau Sts., Wednesday afternoon. The 21 creditors present represented an indebtedness of about \$6,000. A Mr. Lorio, who represented Rundbach gave the insolvent's liabilities as about \$11,000. His statement showed the actual assets to be about \$500.

An offer to settle at 50 per cent., in four notes running from January to October, 1895, indorsed by Mrs. Rundbach, was made and refused. The majority of the creditors present put their claims into the hands of a committee consisting of the chairman of the meeting, Wm. I. Rosenfeld, Harry Oppenheimer, of H. Z. & H. Oppenheimer, and H. M. Condit, secretary of the Board, who are to investigate and decide on what action the creditors should take.

Saturday a woman stole \$2,000 worth of diamonds from T. & E. Dickinson's jewelry store, Buffalo, N. Y., got well away with her booty, and probably would have made good her escape had she not become intoxicated.

ESTABLISHED 50 YEARS.

RANDEL, BAREMORE & BILLINGS,

IMPORTERS OF

DIAMONDS,

AND OTHER PRECIOUS STONES.

FINE PEARLS A SPECIALTY.

MANUFACTURERS OF

DIAMOND JEWELRY,

IN THE LATEST DESIGNS.

Diamonds Recut in Modern Styles or Repaired on Premises.

58 Nassau Street,  
 29 Maiden Lane,  
 NEW YORK.

1 Tulp Straat,  
 AMSTERDAM.

1 St. Andrews St.,  
 Holborn Circus,  
 LONDON, E. C.



ESTABLISHED 1841.



TRADE MARK.

CARTER, SLOAN & CO.,

MANUFACTURERS OF GOLD JEWELRY,

No. 15 MAIDEN LANE,

NEW YORK.

A. CARTER JR.  
 A. K. SLOAN.  
 C. E. HASTINGS.

GEO. R. HOWE  
 WM. T. CARTER  
 WM. T. GOUGH.

FACTORY, NEWARK, N. J.



JOHN N. DISSELKOEN,

Cutter and Importer of

DIAMONDS

FACTORY  
 76 LANGEBLEEKERSPAD  
 AMSTERDAM.

19 East 16th St.,  
 NEW YORK.

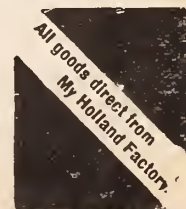

**GORHAM  
MFG.**

**CO.,**

**SILVER  
SMITHS,**

**Broadway  
and**

**19th St.,  
New York.**



**WORKS AT  
PROVIDENCE, R. I.**

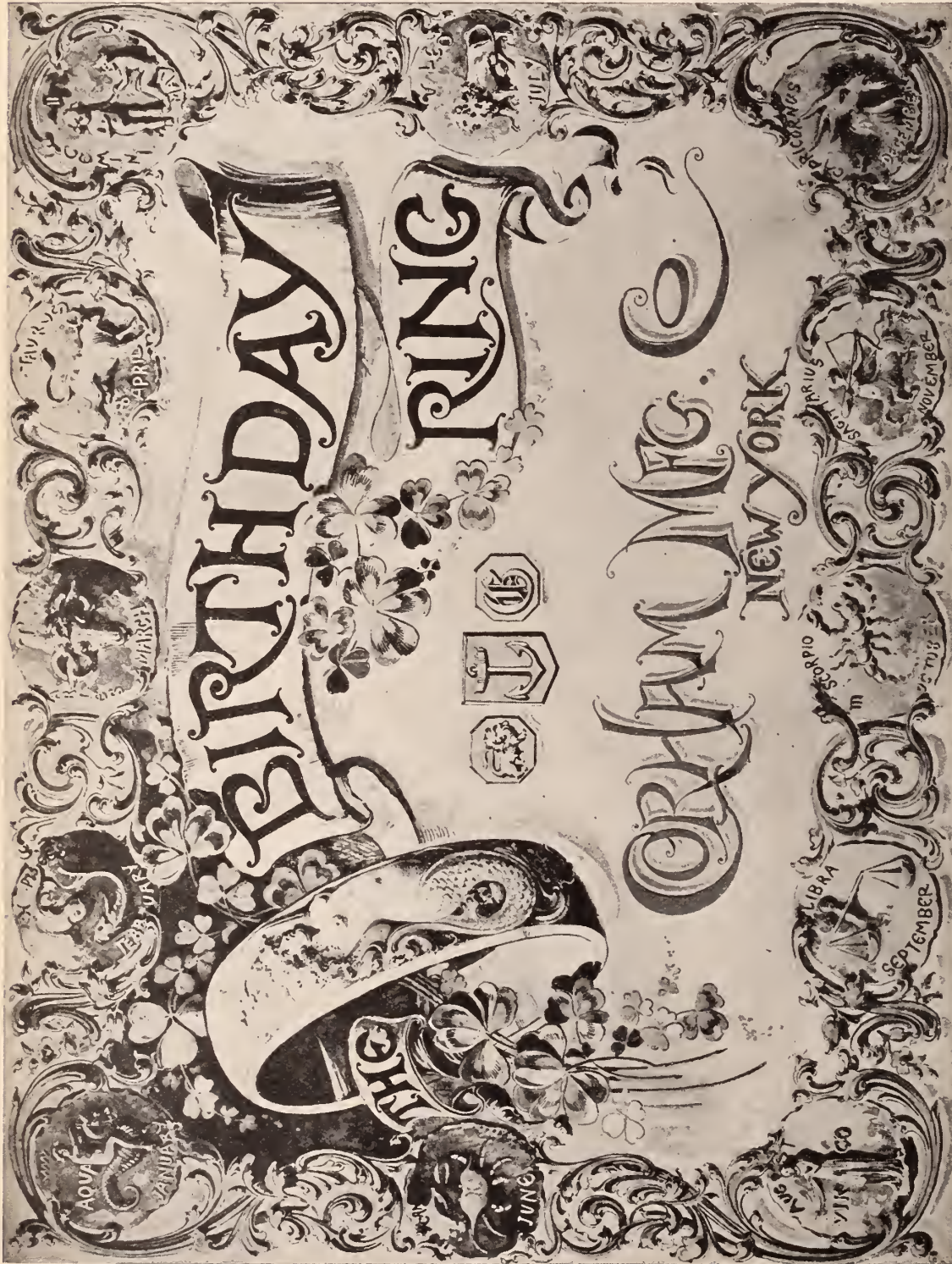

**Branch Offices;**

- 23 Maiden Lane,  
New York,
- 43 West Street,  
Boston.
- 137 State Street,  
Chicago.
- 120 Sutter St.,  
San Francisco.
- 36 Ave. de l'Opera,  
Paris, France.

**T**HE Birthday ring made in Sterling Silver is supplied in all regular sizes, and in twelve designs, one for each month, combining in artistic relief the respective sign of the Zodiac and the flower for the month, as on our Birthday, Tea and Coffee Spoons and other pieces. A display card, of which the above cut is a reproduction, will be sent upon receipt of request, to the Retail Jewellery Trade only.

# The Jewelers' Circular

AND  
HOROLOGICAL REVIEW.

PUBLISHED EVERY WEDNESDAY BY

THE JEWELERS' CIRCULAR PUB'G CO.,

189 BROADWAY, NEW YORK CITY.

A JOURNAL DEVOTED TO THE INTERESTS OF JEWELERS, WATCHMAKERS, SILVERSMITHS, ELECTRO-PLATE MANUFACTURERS, AND ALL ENGAGED IN KINDRED BRANCHES OF INDUSTRY.

Our Editorial columns will contain our own opinions only, and we shall present in other columns only what we consider of interest or value to our readers. Advertising matter will not be printed as news.

Advertising rates in THE CIRCULAR are lower, considering the number of tradesmen reached by its large circulation, than in any other jewelry journal.

Notices of changes in standing advertisements must be received one week in advance; new matter can be received up to Monday.

## INFORMATION FOR SUBSCRIBERS.

### Terms of Subscription, Postage Prepaid.

PER ANNUM.

United States and Canada, . . .	\$2.00
Foreign Countries in Postal Union, . . .	4 00
Single Copies, . . . . .	.10

New subscribers can commence at any time.

Payments for THE CIRCULAR when sent by mail, should be made in a Post Office Money Order, Bank Check or Draft, or an Express Money Order or Registered Letter. All postmasters are required to register letters whenever requested to do so.

Pay money only to authorized collectors having proper credentials.

Returning your paper will not enable us to discontinue it, as we cannot find your name on our books unless your address is given.

In changing address always give the old as well as the new one. Your name cannot be found on our books unless this is done.

We will continue to send papers until there is a specific order to stop, in connection with which all arrearages must be paid; but such an order can be given at any time, to take effect at the expiration of the subscription. All such orders will be promptly acknowledged by mail.

The Courts have decided that all subscribers to Journals are responsible until arrearages are paid in full and an order to discontinue has been received by the publisher.

Member of the American Trade Press Association.

Vol. XXIX. Dec. 5, 1894. No. 19.

NOW that the legislative sessions of the several States are soon to open it is to be hoped that the jewelers will exercise every endeavor to have their respective legislatures pass a law regulating the stamping of silver manufactures, that will have features in common to those of the other States. THE CIRCULAR has prepared drafts of such a law which will, we understand, be presented by representative jewelers of several States.

### The Sentiment of Precious Stones.

HOW deep the sentiment expressed by precious stones is set in the hearts of the people is seen from the will of one Mrs. Josephine M. Bacchus, of Brooklyn, N. Y. To each of her daughters, she leaves a diamond screw earring, the stones of which are to be reset in rings and worn on the third finger of the right hand "in memory of their mother," and to remind them of the three virtues Mrs. Bacchus would have them possess—"truth,

purity, and patience." To her son she leaves a set of cameo earrings, to be made into cuff buttons, to "remind him of what I would desire him always to possess—a good name before riches, purity, and truth." With the loud mouthings of ephemeral revolutionists ringing in our ears, it is a sincere pleasure to be once more assured that the poetry that has for many centuries been felt to reside in precious stones, one of nature's most beautiful manifestations, is still inherently felt in the heart.

### The Advantages of the Alliance.

THE advantages of the *modus operandi* of the Jewelers' Security Alliance are brought to our mind in considering the circumstances surrounding the robbery in the jewelry store of F. P. Jolls, Attica, N. Y. At 4 o'clock of the morning of Nov. 24 the safe in this unfortunate jeweler's store was blown open and the best part of his stock carried off, amounting in value to about \$1,000. The burglars were identified and a good description of them given to him. Mr. Jolls went to Buffalo and Rochester and notified the police, but these guardians of life and property can devote but a small part of their time to Mr. Jolls' case. If Mr. Jolls had been a member of the Jewelers' Alliance he would have notified the central office and in a short time the burglary would have been known all over the United States. The Alliance would have sent detectives and clues would have been followed up from the beginning. What makes the burglary unusually deplorable is the fact that on Dec. 1 was to be inaugurated an auction sale of the jeweler's stock for the benefit of his creditors. The unfortunate conjunction of circumstances places Mr. Jolls in a very delicate position. Why the large majority of burglaries in the jewelry trade are of the stores of non-Alliance members is self-evident—the thieves have a better chance of evading the clutches of the police.

### Rhode Island Retailers to Form a State Organization.

PROVIDENCE, R. I., Dec. 1.—The retail jewelers of this city, who have already held two or three preliminary meetings for the purpose of forming an organization, and have elected a portion of the officers necessary for such an association, met Friday evening at the Hotel Dorrance. Newton Dexter, who has been the prime mover in the formation of these associations in other States, was present and directed the matters.

Those who were present are very reticent about giving any information as to what was done, but it is understood that the matter of forming a local organization was held in abeyance until after a State Association had been organized which would probably be immediately following the holidays.

### The Diamond Polishers Organize the Diamond Workers' Union.

The strike of the New York diamond polishers announced in last week's CIRCULAR is still on. Tuesday afternoon, Nov. 27th, the proprietors of the establishments were made acquainted with the demands of the polishers who had decided on a new schedule which called for an increase of from 30 to 50 per cent. over the former wages paid. This was refused.

Later in the week the strikers were joined by the men in M. Hudemacher's department in Stern Bros. & Co.'s factory, all but two of the few remaining with D. De Sola Mendes & Co., and some others in the smaller shops. Among the factories affected thus in New York were Arnstein Bros. & Co., Stern Bros. & Co., Herman Levy, D. De Sola Mendes & Co., Wallach & Schiele, Zilver Bros., Brooklyn, and Sanders & Bruhl Mfg. Co., Newark, making the total number of men on strike between 250 and 300.

The New York polishers formed a union with a membership of 158 members, while another branch was formed in Brooklyn with 56 members. Monday morning a member of the State Board of Arbitration met a few of the proprietors of the cutting shops with the view to harmonize the differences between them and their employes. He offered to use his good offices to settle the strike. The meeting, however, has been without effect, as yet. The employers whom THE CIRCULAR reporter saw Monday, all expressed themselves as confident of winning eventually, stating that there was no scarcity of goods.

At a meeting of the Central Labor Union at Clarendon Hall, Sunday afternoon, Daniel Harris reported that for the first time the diamond workers had been organized. "These people," he said, "are out on strike for an increase of wages. They came here from Europe under contract, thinking conditions were better here. When they began to mingle with the American workmen in this city, Brooklyn and Newark they found that the money they were earning here had not so much purchasing power as the money they earned in Europe, and that they were actually worse off here. Three years ago there were only fifty-five people in the industry here. The employers have found that this is the best market in the world, and one large firm has already come from Amsterdam, and another is coming that will employ 400 people. It is going to be a great industry."

Mr. Harris' report was received and the Diamond Workers' Union will become part of the Central Labor Union.

Sheriff Fahrenbach on Monday afternoon last sold the stock of jeweler Romich, Hamburg, Pa., to satisfy an execution for \$1,570.49, issued at the instance of L. C. Romich. J. Ed. Miller, Esq., purchased the bulk of the stock. Mr. Romich will continue business for the present.

**New York Notes.**

N. Glauber, of N. Glauber & Co., leaves to-day on the *Majestic* for Europe.

Fred L. Martin, of Eichberg & Co., sails for Europe to-day on the *Majestic*.

E. B. Meyrowitz has entered a judgment against Adolph Bechtold for \$101.29.

S. & B. Lederer have filed a judgment against Moses M. Eckstein for \$145.53.

Leopold Weil & Co. have filed a judgment for \$166.53 against Jno. E. Jarck.

Holden & Knox have entered a judgment for \$166.76 against Jas. H. Dederick, Jr.

A judgment for \$295.05 has been entered against M. L. Flatow in favor of S. & B. Lederer.

A judgment for \$75.67 has been filed against the Duryea Jewelry Co. by C. H. S. Hubbard.

Abraham Selover, Jersey City, has given a chattel mortgage on jewelry to S. Sherwood for \$500.

The judgment for \$466.91 entered March 25, 1890, by E. L. Anrich against Louis Stern, has been satisfied.

Judgments for \$272.59 and \$1,935.82 have been entered against the Columbia Time Recorder Co., by F. R. Munrath.

W. K. Loring, 1416 Third Ave., has renewed a chattel mortgage for \$306 on jewelry fixtures to Adolph Goldsmith.

Theo. M. Woodland and Wm. H. Jones, both of the firm of Larter, Elcox & Co., 21 Maiden Lane, intend to form a new firm and start in business about Jan. 1st.

Samuel Pitzele, formerly with Falkenau, Oppenheimer & Co., will shortly start in business as a retail jeweler. He has not yet decided on the location for his store.

Miss Wilhema Schultz has succeeded to and is now continuing the retail jewelry business at 173 Sixth Ave., formerly conducted at that address by her father, the late Christian Schultz.

Donald Lauer Kerr, the infant son of Wm. B. Kerr, of Wm. B. Kerr & Co., died suddenly in East Orange, N. J., Tuesday evening, Nov. 27th. The funeral took place Friday afternoon.

Richard Horstmann, who recently removed his New York office from the Metropolitan Life Insurance Co. building to the Jackson building, Union Square, sailed for Europe Dec. 1 on the *Lucania*.

By an order signed by Judge Bookstaver, in the Court of Common Pleas, last week, Richard M. Henry has been appointed referee to take and state the accounts of James T. Scott as assignee of Albert Janicke, who failed Jan. 2d last.

Among the principal New York creditors of Braverman & Bostelman, San Francisco and 14 John St., New York, whose failure is announced elsewhere in this issue are: Bruhl Bros. & Co., Wm. S. Hedges & Co., E. L. Anrich, Heilbronn & Blank, Max Freund & Co., and E. Aug. Neresheimer & Co.

Justice Patterson, in the Supreme Court Monday, appointed David J. Lees the receiver of the Kimberley Diamond Co., in the proceedings for a voluntary dissolution published in *THE CIRCULAR* Nov. 21st. Hyman Hein was the president, Max Goldsmith the treasurer, and Harry Arnold, secretary.

Among the firms who will, about May 1st, move into the Prescott building, the structure erecting at S. W. corner of John and Nassau Sts., are: Eichberg & Co., 3, Maiden Lane; Oppenheimer Bros. & Veith, 35 Maiden Lane; Sam Stern & Co., 39 Maiden Lane; Sig. Hirschberg, 78 Nassau St.; and Shultz & Rudolph, 24 John St.

The United States Circuit Court of Appeals yesterday heard argument on the appeal from the decision of Judge Coxe which sustained the demurrer interposed by the E. Howard Watch & Clock Co., to the suit brought under the Sherman Anti-

Trust law by the Dueber Watch Case Mfg. Co. against the manufacturers of watch cases and movements. Decision was reserved.

Emma Schorling, the 18 year old girl who, as recently told in *THE CIRCULAR*, has been under arrest on indictments charging her with shoplifting at the stores of several Brooklyn jewelers, was released from custody last week. On petition of her former pastor, Rev. T. C. McClelland, Judge Moore had the indictments for grand larceny withdrawn, and Police Justice Goetting, Thursday, suspended sentence on the charges of petit larceny.

Judge Lawrence, in the Supreme Court last week signed an order appointing Gustav R. Hamburger receiver for the defunct firm of C. McCulloch, Beecher & Co., in place of Samuel Goldberg, deceased, who was appointed by the decree entered April 24, 1893, which set aside the assignment of that firm. The suit which was mentioned in *THE CIRCULAR* at the time, was brought by Franklin Bien for the Ansonia Clock Co. and other judgment creditors.

**Last Week's Arrivals.**

The following out-of-town dealers were registered in New York during the past week: F. H. Wells, Syracuse, N. Y., Imperial H.; F. Gilbert, Troy, N. Y., Gilsey H.; C. H. Harner, Va., St. Denis H.; A. M. Dueber, Canton, O., Astor H.; W. H. Jewett, Cortlandt, N. Y., St. Stephen H.; W. L. Spencer, Richmond, Ind., Metropole H.; W. H. Sibley, Boston, Mass., Everett H.; C. Gill, Lancaster, Pa., Sturtevant H.; N. Galt, Washington, D. C., Westminster H.; J. R. Armiger, Baltimore, Md., Astor H.; G. S. Morrill, Boston, Mass., B'way Central H.; A. G. Paul, Boston, Mass., Grand H.; J. Zineman, Philadelphia, Pa., Albert H.; C. E. Van Norman, Springfield, Mass., Grand Union H.; F. E. Ladd, Springfield, Mass., B'way Central H.

ESTABLISHED 1843.

Highest Awards in Every Competition

LEROY W. FAIRCHILD & Co.,  
3 Maiden Lane, New York City.

Gold Pens, Gold and Silver Pencils and Pen Cases,

The Handsomest and Cheapest Line of Goods in the Market.

WORKS: 3D AVENUE AND OGDEN ST., NEWARK, N. J.



**L. TANNENBAUM & Co.,**  
IMPORTERS AND CUTTERS OF

**Diamonds and Precious Stones,**

Cor. Maiden Lane & Nassau St.

**NEW YORK.**

25 Hatton Garden, London.

TELEPHONE, LONG DISTANCE, 1959 CORTLAND.

## Special Announcement.

Mr. L. Tannenbaum begs to notify his customers and the trade in general, that he has largely extended his facilities for cutting and polishing. Hereafter he will cut and polish not only RUBIES and SAPPHIRES, which has been done for the past 15 years with increasing and gratifying success, but

# DIAMONDS

and all other stones which undergo this process.

Modern machinery of the best and most approved pattern, and workmen of the highest class will enable Mr. Tannenbaum to offer, direct from the cutter's hands, that excellent workmanship demanded by American buyers, at

## PRICES THAT DEFY COMPETITION.

Nor will buyers of Diamonds be the only people benefited. Mr. Tannenbaum imported a five years' supply of rough Rubies and Sapphires DUTY FREE under the old tariff. These goods are now being cut and polished and it is very evident that in these particular stones he can make UNAPPROACHABLE PRICES.

New York as the future Diamond Market is not a phantasy. American cutters will be shown an assortment of rough, at prices which will perhaps cause them to believe that this has already been brought about. All arrangements have been made by the firm for enormous shipments of DIAMONDS, EMERALDS, PEARLS, SPINELS, CATSEYES, MELLEES and all kinds of Precious Stones, although to-day the assortment offered by L. Tannenbaum & Co. ranks second to none in this country.

HIGHEST PRICE PAID for all AMERICAN PEARLS and OTHER PRECIOUS STONES.



342

344

340

326

325

336



106

104

188

324



332

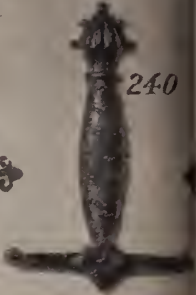

240

98

45

46

207

200

78

67



329

205

111

328

79

327

59

185

187

179

178

51

58

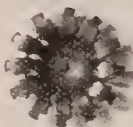
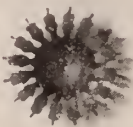

210

74

150

25

42

119

86

40

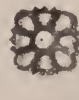

134

66

2

165

153

65

18

337

71



39

164

346

8

154

151

27

44

28



19 Rococo.

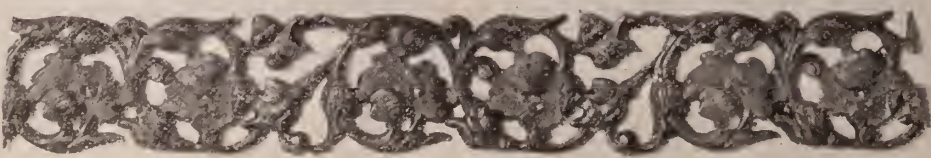

23 Rococo



27 Rococo



All Designs are Fl

321

322

339

338

1867  
**THOMAS W. LIND.**  
 Manufacturer of  
*Jewelers Findings*  
 67 Friendship St  
 PROVIDENCE,  
 R. I.  
 1895

267

323

1895

18 Gallery

195

236

237

250

239

123

196

72

345

84

116

91

26 Gallery

12 Gallery

268

262

234

230

280

Hal Pen Ornaments, Formed and Flat.

17 Gallery

1 Spoon Bowl.

Any Design made in

Gold, Silver, Plate and Brass.

Metal Work Cut and Drawn To Order.

SIZE.

## Sells at Sight



Cup and Saucer with Sterling Silver Spoon  
retailing at \$1.00 Complete.

Our price to dealers in dozen lots, \$8.00  
per dozen, with ribbons.

Cups and Saucers, Assorted Decorations

SEND CHECK WITH ORDER.

# Levy, Dreyfus & Co.,

Art Goods for Jewelers,

9 & 11 Maiden Lane, NEW YORK.

## THEODORE C. STEINHAUS,

— MANUFACTURER OF —

# Fine Cases and Trays

For JEWELRY, SILVERWARE, &c.

SAMPLE CASES AND TRAYS FOR TRAVELERS.

Fancy Hard Wood Chests for Silverware, &c.

Liniags, Cushions, Mounting, etc., for Silver Novelties.

10 MAIDEN LANE, NEW YORK.

## Pittsburgh

Jacob Shupinski, a Penn Ave. jeweler, suffered a loss of \$1,300 last week by fire.

Biggard & Wolf have decided to give up the retail and adhere to the wholesale business.

S. L. Wise, Fredericksburg, Va., has closed out his store and is now with A. E. Siedle.

J. T. Littell recently received the degree of doctor of refraction from the Philadelphia Optical College.

On Nov. 25 the jewelry store of R. H. Kinkead, Derry, Pa., was robbed. Gold watches and other jewelry were taken.

Benj. Robinson, of F. A. Robinson & Son, Clarksburg, W. Va., was in this city last week buying his holiday goods. His father died about 10 days ago.

John Kennedy, a jeweler of Wilkensburg, and Miss Annie Stitts, of this city, were quietly married last Wednesday evening at the residence of the bride.

Among the visiting jewelers last week were: Frank Worrell, Washington, Pa.; H. H. Weylman, Kittanning, Pa.; S. C. Shuster, Latrobe, Pa.; A. A. Poole, Washington, and S. Branchler, Greensburg, Pa.

H. W. Andre sued Emanuel De Roy for \$1,000 damages in Common Pleas Court No. 3. The plaintiff states that he entered into the employ of the defendant on Oct. 8, 1894, under a contract for a certain length of time, but has since been discharged.

Travelers in Pittsburgh during Thanksgiving week were: W. J. Miller, Seth Thomas Clock Co.; Wm. A. Wightman, R. F. Simmons & Co.; D. Skutch, Waterbury Clock Co.; C. I. Untermeyer, Keller & Untermeyer Mfg. Co.; J. Williams, G. Armeny; J. Guntzburger, C. Cottier & Son, Martin Frank & Co.; Arthur Bradshaw, Meriden Britannia Co.; Chas. W. Hempel, Sandland, Capron & Co.; G. C. Booth, Hutchison & Huestis; L. V. Benson, for Frank H. La Pierre; J. D. Underwood,

Champenois & Co.; A. Kiersky, Kraus, Kragel & Kiersky; Robert Welch, Welch & Miller; Wm. Matschke; J. F. Townley; F. A. Frey.

## Canada and the Provinces.

R. Mercer, Seaforth, Ont., has assigned.

E. L. McDonald has opened a jewelry repair shop at Wawanesa, B. C.

J. H. Hall, jeweler, etc., Oxford, Assiniboia, is advertising his business for sale.

The store of John R. McDonald, Hopewell, Pictou Co., N. S., was destroyed by fire on Nov. 22d.

The orange season being now on, the jeweler will find it to his advantage to display articles designed for the proper eating of this delicious fruit. On another page Rogers & Bro., the manufacturers of the celebrated ★ Rogers & Bro. A1 brand of flatware, illustrate two of their devices, an orange knife and an orange spoon. This firm also carry in stock an extensive variety of patterns in orange sets, orange peelers, orange holders, etc. It may be noted that their orange knife possesses a two-fold advantageous feature: the saw edge at the back adapts it for cutting oranges, while the regular knife edge adapts it for all the requirements of a fruit knife. Rogers & Bro. were the introducers of this device and have had a large measure of success with it.

Christian Mauthe, Cincinnati, O., has given a mortgage for \$500.

Chas. S. Hackey, Caraque, N. B., has judgments for \$244 and \$62 entered against him.

Howard Blake, jeweler, Ipswich, Mass., has gone into insolvency. His liabilities are placed at \$4,867.15; assets consisting of stock in trade, mortgaged for \$1,700, and book accounts.



Just Received Our Fall Importation.

# THE AUDEMIR OPERA GLASSES, SPENCER OPTICAL MFG. CO.,

15 MAIDEN LANE, NEW YORK.

CALL OR WRITE. IT WILL DO YOU GOOD!

## ONE OF THE 400, AND VERY SWELL INDEED.

### THE PERFECT FIT OF OUR No. 918 GOLD EYE GLASS, SWELL END EYE WIRE.

Our Ambition to Make a FAULTLESS GOLD SPEC. and Eye Glass has been realized, and is appreciated. Strength and Beauty Joined Together WITHOUT SOLDER. You "see that hump" no longer. It's gone, and in its place, at ends and bridge, you find that GRACEFUL SWELL, as shown in cut. *This is the Modern and Perfect Frame the public are asking for, made in all weights, sizes, shapes and qualities.*

WE MAKE ALL KINDS OF OPTICAL SPECIALTIES, AND TEACH HOW TO GET BEST RETURNS IN HANDLING THEM.

The Best Made for the Least Money. Also Cheaper Grades. The Greatest Variety of Styles. Great Reductions to Correspond with New Tariff and Other Causes.

SEND FOR NEW SUPPLEMENT.



## News Gleanings.

Isaac Bagley, Menominee, Wis., has failed.

Josiah Grass has removed from Alameda, Cal., to Susanville, Cal.

H. Miller's store, McDonald, Pa., was burned out last week. Loss unknown.

E. B. Simonton, jeweler, Sauk Center, Minn., was united in marriage some days ago to Miss Etta Ervin.

The business of W. A. Murphy, Carson, Ia., was affected by fire a few days ago to the extent of \$900; insurance, \$500.

In a destructive fire in Lyndonville, Vt., last week, the store of H. L. Parker, boots and shoes and jewelry, was burned out.

F. K. Kern, jeweler, El Paso, Tex., has assigned. Liabilities, \$43,000; assets, \$31,000, of which \$11,000 is in book accounts.

A new watch company with a capital of \$1,000,000 is reported to have been organized, and will locate a factory in Passaic, N. J.

E. C. Bennett, of Red Wing, Minn., will open up a stock of jewelry at the old post-office building, Pine Island, Minn., this week.

John Montaire, Ashburnham, Mass., has sold his place on Winchendon road to Mrs. Mary M. Wilson, of Westminster, and has moved to Boston.

Ed. Davidow, Jr., of Davidow Bros., Scranton, Pa., left last week for New York where he will engage in the jewelry business with his brother.

L. Lusky, H. Lusky, J. C. Lusky, A. D. Lowenthal and D. Levy applied for and were granted a charter of the Silberman Jewelry Co., of Nashville, Tenn.

Burglars, a few days ago, entered the jewelry store of John W. Shoultz, Belle Center, O., and secured about \$200 worth of watches, jewelry and revolvers.

Sheriff Fahrenbach, of Berks County, Pa., a few days ago levied upon the contents of Harry C. Romich's jewelry store, at Hamburg, Pa., upon an execution for \$1,570.

Leonard Souter, who for many years has been engaged in the jewelry trade in Chittenango, N. Y., has removed to East Syracuse where he will carry on a similar business.

The verdict obtained by August Kröger, jeweler, Phoenixville, Pa., who sued Sheriff Alexander Ingram for \$2,000 damages, was in the sum of \$100 and not \$1,000 as reported in these columns last week.

The jewelers and opticians of Somerset county, Pa., are waging war against the spectacle peddler. Legal advice has been obtained and they are determined to get rid of this great obstruction to their business.

F. G. B. Weihe, Ocala, Fla., has not sold out his business as reported at first, the bill of sale to Hennegen, Bates & Co., Bal-

timore, Md., being merely a temporary business arrangement. Mr. Weihe is still conducting his business at his old place.

Chalkley Pearson, familiarly known as the "old clock fixer," died at his home at Mechanicsville, Pa., last Sunday, aged 65 years. Pearson is said to have repaired more clocks than any other man in the State.

A well dressed stranger recently went into the jewelry store of Fred Steglich, Grand Rapids, Mich., and looked at a ring which he wished to buy for his niece. After he went out it was found that a \$30 ring was missing.

Forrest Edelman and sister, Miss Laura B. Edelman, of Easton, Pa., have entered into a co-partnership, under the firm name of the Easton Watch and Jewelry Co., and opened last week with a stock of watches, clocks and jewelry in room 1, first floor of the Easton Trust Co. building.

H. T. Bramer, jeweler, Attica, N. Y., writes to the Jewelers' Security Alliance under date of Nov. 26th: "Last Friday night burglars broke open three safes in this small village, and I have every reason to think they passed me because of my membership card which I hang on the knob of my safe."

An alarm of fire at half past five on the morning of Nov. 27th, called the department to the jewelry store of J. Kopelowich-

over, 186 E. Main St., Rochester, N. Y. The flames had made considerable headway before the department arrived and the stock as well the store was badly damaged. The loss is in the neighborhood of \$1,000.

E. P. Wheeler's new jewelry store, in Market St., Paterson, N. J., is beautiful and attractive. It is at the same old stand, but the place has been so enlarged and improved that it will hardly be recognized. It has been extended 20 feet in the rear, so that it is now 75 feet deep. One of the features is a mammoth plate glass mirror, 20 feet in length.

The Herbert Brush Co., Kingston, N. Y., are at present rushed with orders and running at full capacity. They have at present 60 men employed and turn out one hundred different varieties of brushes. Recently they have increased their facilities for the manufacture of jewelers' brushes, which they are making in large quantities. The company do a business of \$150,000 a year.

Minor Stilson died recently at his home in Delhi, N. Y., aged 74 years. For several months he has been in feeble health, but his condition was not considered critical until about an hour before his death. Mr. Stilson was born in Meredith, but has for many years resided in Delhi, and was for a long time a leading jeweler of the county. He was a sutler with the 144th Regiment during the war. From 1881 to 1887 he was treasurer of Delaware county.



# A. WITTNAUER,



Successor to J. EUGENE ROBERT & CO.,

19 MAIDEN LANE, - - NEW YORK.

## Swiss Watches and Movements

—OF—

ALL DESCRIPTIONS, STYLES AND SIZES

—AND—

IN VARIOUS GRADES.

## SPLIT SECONDS, MINUTE REPEATERS AND NOVELTIES.

J. F. Hinds, Webster, Mass., has sold out.

A. F. Pickart, Atlanta, Ga., is selling out at auction.

Thos. Strickland, Chicago, Ill., has confessed judgment for \$567.

John F. Hornberger, Lawrenceburg, Ind., has given a mortgage for \$1,400.

Gerard A. Otwell, Neodesha, Kan., has given a mortgage for \$300.

Frank Luty, watchmaker and repairer, will locate in Jacksonville, Pa.

Green B. Rich has removed from Blackville, S. C., to Micanopy, Fla.

Vosburg & Co., Allegan, Mich., have discharged a mortgage for \$1,375.

Frank Dillenbeck, Chaumont, N. Y., has a judgment for \$274, entered against him.

Sherman Broughler has bought Chas. M. Dick's jewelry store in the Stark block, Greensburg, Pa.

Warren Richmond, Mt. Morris, N. Y., has taken Ed. M. Conklin into co-partnership with him in the jewelry business.

E. R. Patterson and Arthur Wilcox, Manston, Wis., have formed a partnership and started in the jewelry business in Elroy, Wis.

Walter McKean has rented one of the rooms in the new Masonic building, Charleroi, Pa., and will move his jewelry store there.

R. T. Cope, jeweler, Atlanta, Tex., has filed a deed of trust naming A. L. Culberson as trustee. Liabilities about \$1,800; assets not known.

By a fire in Palace block, Meriden, Conn., Wednesday night jeweler Mather's stock was damaged. Friday he settled with the insurance adjusters for \$250.

Mr. Mannieschmidt, a jeweler, who has been for the past several years in the employ of C. Schomburg, Columbus, Ga., has opened a shop of his own in the rear of Stanfield Johnston's store.

## Philadelphia.

Jas. D. Hughes, L. A. Scherr & Co., has returned from a successful southern trip.

F. C. Borheck, 628 Chestnut St., optician, will join I. Bedichimer in the new establishment at the southeast corner of 11th and Sansom Sts.

J. R. Davidson, formerly western manager of H. Muhr's Sons, at Chicago, is now in the east, and has been visiting friends in Philadelphia.

The back window of Benjamin Bernstein's store, 227 N. 9th St., was smashed early on Saturday morning, and several small articles of jewelry were stolen.

Jacob Muhr has taken the large building of the Graham estate, 19th and Hamilton Sts., and will continue the manufacture of the same line of goods formerly made by H. Muhr's Sons.

John T. Sandman, 742 S. 2d St., has confessed judgment in favor of Mr. Hunt. The sheriff's sale was on Tuesday. A creditors' meeting was set for 2 o'clock P.M., the 3d inst., at the office of De Forrest Ballou, attorney, Manhattan building, this city.

Among the salesmen in Philadelphia the past week were: S. Blackinton, W. & S. Blackinton; George S. Melville, Acme Silver Plate Co.; Samuel Zimmern, Henry Zimmern & Co.; Chas. Brinker, Tower & Lyon; Henry Wilson, Plainville Stock Co.; and E. M. Bracker.

Out-of-town buyers here during the week, included: F. C. Baumiller, Frankford, Pa.; M. Whitehead, Tioga, Pa.; J. E. Reidenbach, Riverton, N. J.; Chas. S. Adle, Norristown, Pa.; J. Watson, Manayunk, Pa.; H. W. Bolte, Atlantic City, N. J.; John Dewer, Bryn Mawr, Pa.

The Jewelers' Club had its second smoker and musicale on the 27th ult., and a very excellent and varied programme was presented. Among the guests were George W. Reed, Wm H. Long, Henry Chambers, Geo. W. Scherr, Chas. H. O'Bryon, A. G. Levy, Jas. Kelly, John English, Geo. Smith, Jas. W. Barry, Ed. Ec feltt, Chas. Will-

iams, Jos. Eddy, Barton Hooper and Wm. Mooney. Another smoker will be given next month.

Mr. Schwartz, proprietor of the Penn Jewelry Co., 156 N. 8th St., was held in \$500 bail by Magistrate Wilhere, on Wednesday, on the charge of obtaining money by false pretenses. Mrs. Anna Roberts testified that two months ago she purchased from Schwartz a 14-karat gold ring for which she was to pay \$9. When she got the ring she had it tested and found that it was not of the kind or character ordered, and as Schwartz refused to return the money she caused his arrest.

## Springfield, Mass.

Charles Rogers, optician, and E. C. Watson, manager for O. W. Bullock & Co., are candidates for seats in the Common Council.

William Bowers has sold his Bay State Plating Works located on Taylor St. in this city, to the Holyoke Plating Works, of Holyoke, and the local concern will be moved to the latter city.

The Hampden County Retail Jewelers' Association held a meeting at the Board of Trade rooms last Tuesday evening. The most important business transacted during the meeting was the appointing of a committee to try and compel manufacturers to stamp their goods, thereby designating their quality.

Negotiations have been pending some time for the purchase of Morse's jewelry store, Westfield, and a few days ago the sale was closed to Dexter H. Wetherell and Robert C. Hollister. Mr. Wetherell was formerly employed with J. W. Skiff, but for the past year has been conducting a watch repair shop in Schmidt's block, on School St.

S. S. Wild & Son, Providence, R. I., make a specialty of enameling society emblems, yacht and college flags. For a quarter of a century the work done by this house has ranked among the highest of its kind done in this country. Those who have not tried this firm will do well to do so.

## THE AMERICAN KNIFE AND SCISSORS SHARPENER.

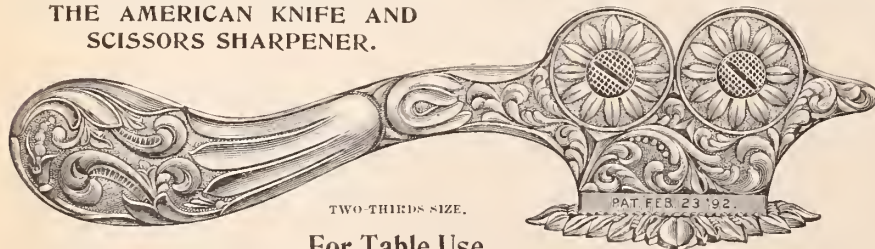

For Table Use.

Special Inducements to Jobbers

... Manufactured only by the

**MOSSBERG WRENCH CO.,**  
ATTLEBORO, MASS.

Makers of Novelties in Silver and Hardware.

FOR SALE BY

F. M. Sproehle & Co.,  
Chicago, Ill.

E. G. Webster & Son,  
New York.

L. Straus & Sons, New York.

Oskamp, Nolting & Co.,  
Cincinnati, O.

Baldwin, Miller & Co.,  
Indianapolis Ind.

Eliassof Bros. & Co.,  
Albany, N. Y.

Thos. Long & Co., Boston, Mass.

Dame, Stoddard & Kendall,  
Boston, Mass.

## Practical and Handsome.

A Silver Plated Knife and Scissors Sharpener, retailing at a popular price. Perfect in action, nothing to wear out. Cutting discs of finest hardened steel. An ordinary sharpness or a RAZOR EDGE can be acquired in a few moments.



FOR DESK USE.



Traveling representatives may consider these columns open for the publication of any news or items of interest regarding themselves or their confreres.

**A**MONG the travelers in Kansas City recently were: C. A. Boynton, Wm. B. Kerr & Co.; P. H. Smith, Whiting Mfg. Co.; N. D. Prentiss, A. G. Stein, L. H. Keller & Co.; E. E. Parmelee, Wilcox Silver Plate Co.; C. M. Davis, New Haven Clock Co.; Frederick Pease, Chas. Parker Co.; F. L. Mueller, for Reinhold G. Ledig; F. N. Carpenter, Alfred H. Smith & Co.; I. M. Berinstein; E. H. Hutton, Geoffroy & Co.

W. S. Pond, traveling for E. G. Webster & Son, Chicago, returned from his southern trip Thanksgiving Day with reports of good sales in his territory. C. F. Coutts had the same report to make of his northwestern trip for the same house on his return, Dec. 1.

Eastern jobbers and manufacturers represented in the Twin Cities last week were: Simpson, Hall, Miller & Co., by W. F. Adams; Meriden Britannia Co., by W. C. Wood; Albert Berger & Co., by Albert Somborn; Wm. Rogers Mfg. Co., by A. H. Clinger.

The following traveling salesmen passed through Detroit last week: A. Pinover, A. Pinover & Co.; Mr. Matschke, Kuhn, Doeflinger & Co.; Mr. Becker, Jos. Fahys & Co.; L. Combremont; Louis E. Fay, Kirby, Mowry & Co.; E. F. Badoux, Spencer Optical Mfg. Co.; S. W. Pickering, Shoemaker, Pickering & Co.; Mr. Cook, Bergstein & Son; O. C. Lane, Reed & Barton; James A. Cheney, Ludwig Nissen & Co.; Matthias Stratton, Jno. W. Reddall & Co.; F. L. Goddard, George W. Shiebler Co.; Mr. Davidson, Harrison Bros & Howson; Frank L. Mueller; J. C. Alexander, with Frank W. Smith; W. C. Coombs, Edward W. Sanford & Co., and a representative of the Bristol Brass & Clock Co.

Traveling representatives for jewelry houses found in Syracuse, N. Y., the past week were: Benj. Westervelt, Waterbury Watch Co.; Wm. W. Middlebrook, B. A. Ballou & Co.; Max Traub, Herzog, Goldsmith & Frank; Stephen B. Kent, Wm. H. Ball & Co.; F. W. Bliss, Unger Bros.; Fred Clarkson, Snow & Westcott; Emanuel Jacobson, Jacobson Bros.; H. C. Schwartz, Krentz & Co.; M. Adler; Henry Pinover, A. Pinover & Co.; J. S. Beatty, L. Sauter & Co.; L. Schwab, New Haven Clock Co.; T. C. Nicholson, Flint, Blood & Co.; Mr. Sulzberger, Sulzberger & Gunzberger; M. Hammel, Keller, Ettinger & Fink; A. F. Bailey, Jr., Wm. M. Fisher & Co.; also representatives of Kimmey & Gladwell and S. Valfer & Co.

"Name all the salesmen that are in the habit of coming to Boston, and you won't

be far from correct on your list of traveling men in town during the week," said one jobber who was asked last Saturday for a list of his callers. "You can say the holiday trade is all we could expect, much better than we did expect, too," he added, "and there are a good many buyers here in the run of a week from all parts of New England." This was the story with most of the jobbing houses, the general opinion being that retailers are lightly stocked this year and the November run of business is likely to continue close up to Christmas week. The demand is by no means confined to novelties, but includes calls from the entire range of staple and seasonable jewelry and wares.

### GREETING!

**C**OMETH soon the Christmas-time;  
List ye to my Christmas rhyme:

Muffled figures hurry by,  
While from early Winter sky,  
Causing heart and face to glow,  
Whirling, dancing, falls the snow.  
Summer birds have flown away,  
Leaf and flower are in decay;  
Yet we shed no mourning tear—  
Christmas-time is drawing near.

Now the inner music flows  
Through a heart that tender grows,  
And it fills me through and through  
And my love goes out to you,  
Bridging over time and space,  
Hedging in one fond embrace  
You to whom I pen this rhyme:  
Greeting! Merry Christmas-time!

DE LANCEY STONE.

# Great Sacrifice Watch Sale.

A RARE OPPORTUNITY TO BUY FINE WATCHES

BELOW THE PRICE OF ORDINARY.

Having decided to discontinue the "Complete Watch" branch of our business and to hereafter confine our trade exclusively to watch movements, we offer our large and superb stock of Paillard Non-Magnetic Ladies' and Gentlemen's Fine Gold Watches, Plain and Complicated, at prices less than manufacturing cost. These watches are high class and carry with them our full warrant and guarantee.

This entire stock must be closed out, regardless of cost, before January 1st, to make room for regular movements. If you have a trade in Fine Watches, or appreciate high class goods, or if you have a customer to whom you can sell a Fine Watch, this is the greatest opportunity ever offered and

ONE YOU SHOULD TAKE ADVANTAGE OF.

Selection Packages sent to responsible dealers. Parties unknown to us will please furnish New York references. Descriptive "Sacrifice Sale" Circular mailed upon application.

A. C. SMITH WATCH CO., 177 Broadway, New York.

## CLASSIFIED INDEX TO ADVERTISEMENTS.

All Advertisements are entitled to one insertion under proper heading. Extra insertions, \$6.00 per annum.  
Extra Headings, \$12.00 per annum.

<b>Art Pottery, Bric-a-brac, Etc.</b>	Page.	<b>Gold and Rolled Plate Jewelry.</b>	Page.
Bing, Ferdinand & Co., 106 Grand St., N. Y. . .	50	Foster & Bailey, Providence, R. I. . . . .	3
Bradley & Hubbard Mfg. Co., Meriden, Conn	8	<b>Gold Jewelry.</b>	
Hinrichs & Co., 29 & 31 Park Place, N. Y. . . .	55	Aikin, Lambert & Co., 19 Maiden Lane . . . .	4
Leonard, P. H., 76 & 78 Reade St., N. Y. . . .	52	Carter, Sloan & Co., 15 Maiden Lane, N. Y. . .	21
Le Boutillier & Co., 860 Broadway, N. Y. . . .	16	Cross & Beguelin, 17 Maiden Lane, N. Y. . . .	4
Levy, Dreyfus & Co., 9 & 11 Maiden Lane, N. Y. . . . .	32	Hedges, A. J. & Co., 6 Maiden Lane . . . . .	50
Straus, L. & Sons, 42 to 48 Warren St., N. Y. . .	49	Larter, Elcox & Co., 21-23 Maiden Lane, N. Y.	50
<b>Assayers &amp; Refiners.</b>		<b>Gold and Silver Novelties.</b>	
U. S. Smelting & Refining Works, 25 John St., N. Y. . . . .	56	Riley, John A., & Sloan Co., Ltd., Broadway and 17th Street. . . . .	13
<b>Auctioneers.</b>		Waite, Thresher Co., Providence R. I. . . . .	9
Boyle, Davis & Goodman, 63 5th Ave., N. Y., 611 Pennsylvania Ave., Washington, D. C. . . .	53	<b>Horological Schools.</b>	
Comrie, A. J., 22 John St., N. Y. . . . .	42	Parson's School for Watchmakers, Peoria, Ill. . .	41
H. M. Rich & Co., 21 School St., Boston, Mass. . . . .	37	Philadelphia College of Horology, 623 Heed Building, Phila., Pa. . . . .	54
<b>Brownie Novelties.</b>		<b>Insurance.</b>	
Griffith, R. L. & Son, 129 Eddy St., Provi- dence, R. I. . . . .	49	Fidelity & Casualty Co., 140-146 Broadway. . . .	55
<b>Badges, Medals, Etc.</b>		<b>Jewelers' Findings.</b>	
Stockwell, E. R., 19 John St. N. Y. . . . .	54	Lind, Thos. W., 67 Friendship St., Provi- dence, R. I. . . . .	28-29
<b>Carborundum.</b>		<b>Jewelry, Silverware and Optical Cases.</b>	
The Carborundum Co., Monongahela, Pa. . . . .	53	Steinhaus, T. C., 10 Maiden Lane, N. Y. . . . .	32
<b>Chains.</b>		<b>Jobbers, Watches, Diamonds, Etc.</b>	
Kent & Stanley Co., Providence, R. I. . . . .	10-11	Allen, Benj. & Co., Chicago, Ills. . . . .	41-13
<b>Chronometers.</b>		Aikin-Lambert Jewelry Co., 19 Maiden Lane. . .	8-54
Heinrich, H. H., 14 John St., New York . . . .	53	Brethauer Watch and Jewelry Co., Chicago, Ill. .	37
Bliss, John & Co., 129 Front St., N. Y. . . . .	14	Myers, S. F. & Co., 48 Maiden Lane, N. Y. . . .	56
<b>Clocks, French, English and American.</b>		Schroder, D. & Co., 252 Race St., Cincinnati, O. . . . .	42
Ansonia Clock Co., 11 Cliff Street, N. Y. . . . .	2	Sproehle, F. M. & Co., Chicago, Ill. . . . .	43
Evans, W. F. & Sons, Hensworth, Birming- ham, England. . . . .	8	Stein, Ellbogen Co., Chicago, Ill. . . . .	17
Jacques, Chas., Clock Co., 22 Cortlandt St., N. Y. . . . .	56	<b>Musical Boxes.</b>	
Self-Winding Clock Co., 26 Broadway, N. Y. . .	56	Cuendet, E. L., 21 John St., N. Y. . . . .	13
<b>Cut Glass.</b>		Jacot & Son, 39 Union Square, N. Y. . . . .	54
Clark, T. B. & Co., 860 Broadway, N. Y. . . . .	50	<b>Ophthalmic College.</b>	
<b>Diamond &amp; Precious Stone Importers.</b>		St. Louis Ophthalmic College, St. Louis. Mo. . .	41
Cottier, C., & Son, 14 Maiden Lane, New York	56	<b>Optical Goods.</b>	
Disselkoben, John N., 19 E. 16th St., N. Y. . .	21	Berger, Albert & Co., 47 Maiden Lane, N. Y. . .	5
Falkenau, Oppenheimer & Co., 40 Maiden	56	Geneva Optical Co., Chicago, Ills. . . . .	41
Hedges, Wm. S. & Co., 170 Broadway, N. Y. . . .	56	Queen & Co., Philadelphia, Pa. . . . .	56
Kahn, L. & M. & Co., 172 Broadway, N. Y. . . .	50	Spencer Optical Mfg. Co., 15 Maiden Lane, N. Y.	32
Kipling, R. A., Hays Bldg., N. Y. . . . .	20	<b>Pens, Pencils, etc.,</b>	
Randel, Baremore & Billings, 29 Maiden Lane	21	Aikin, Lambert & Co., 19 Maiden Lane, N. Y. . .	8-54
Smith, Alfred H. & Co., 182 Broadway, N. Y. . .	20	LeRoy, Fairchild & Co., 3 Maiden Lane. . . . .	24
Tannenbaum, L., & Co., cor. Maiden Lane and Nassau St., N. Y. . . . .	25	Smith, H. M. & Co., 83 Nassau St. . . . .	39
<b>Diamond Cutters.</b>		<b>Photo-Miniature.</b>	
Arnstein Bros., 45 John St., N. Y. . . . .	19	Favre Leon, 107 East 26th St., N. Y. . . . .	49
Fox Bros. & Co., 68 W. 4th St., Cincinnati, O.	18	<b>Ring Makers.</b>	
Oppenheimer Bros. & Veith, 35 Maiden Lane, N. Y. . . . .	7	Bowden, J. B. & Co., 192 Broadway, N. Y. . . .	13
Stern Bros. & Co., Cor. John & Nassau St., N. Y. . . . .	12	Bryant, M. B. & Co., 10 Maiden Lane, N. Y. . .	54
<b>Diamond Polishing Mills.</b>		Wood, Jno. & Sons . . . . .	8
Arthur Co., The, 86 John St., New York . . . .	19-56	<b>Safes.</b>	
<b>Fine Stationery.</b>		Mosler, Bahmann & Co., 518 B'way, N. Y. . . . .	13
Parsons & Greene Co., 18 Murray St., N. Y. . .	5	<b>Sample Trunks</b>	
		Crouch & Fitzgerald, 161 Broadway, N. Y. . . .	5
		<b>Show Cases.</b>	
		Smith, B. & W. B., 220 W. 29th St., N. Y. . . . .	56
		<b>Silver Plated Ware.</b>	
		Bell, O. E. & Co., 51 E. 4th St., Cincinnati O. .	39
		Pairpoint Mfg. Co., New Bedford, Mass. . . . .	5
		Rogers & Bro., 16 Cortlandt St., N. Y. . . . .	15
		The Wm. Rogers Mfg. Co., Hartford, Conn. . . .	5
		Webster, G. A., Chicago, Ill. . . . .	42
		<b>Sterling Silver Novelties.</b>	
		Codding Bros. & Heilborn, North Attleboro Mass. . . . .	14
		Hagan, White & Co., 243 W. 23d St., N. Y. . . .	56
		Kent & Stanley Co., Providence, R. I. . . . .	10-11
		Knowles, J. B. & S. M. Co., Silversmiths' Hall, Union Square, N. Y. . . . .	43
		Richardson, Enos. & Co., 23 Maiden Lane. . . .	49
		<b>Sterling Silverware.</b>	
		Campbell-Metcalf Silver Co., Providence, R. I. .	49
		Fuchs, Ferd. & Bros., 808-810 Greenwich St., N. Y. . . . .	20
		Gorham Mfg. Co., 19th St. & Broadway, N. Y. City. . . . .	22
		Towle Mfg. Co., Newburyport, Mass. . . . .	55
		Wallace, R. & Sons Mfg. Co., 3 Park Place, . .	6
		Wood & Hughes, 16 John St., N. Y. . . . .	53
		<b>Tissue Paper.</b>	
		Dexter, C. H., & Sons, Windsor Locks, Conn. . .	8
		<b>Tortoise Shell Goods.</b>	
		Potter, W. K., Providence, R. I. . . . .	20
		<b>Tool Manufacturers and Dealers.</b>	
		Allen, Benj. & Co., Chicago, Ill. . . . .	13-41
		Combermont, L., 45 Maiden Lane, N. Y. . . . .	37
		American Watch Tool Co., Waltham, Mass. . .	13
		Moseley & Co., Elgin, Ill. . . . .	41
		Mossberg Wrench Co., Attleboro, Mass. . . . .	34
		Oliver, W. W., Buffalo, N. Y. . . . .	42
		<b>Trunks and Traveling Bags.</b>	
		Crouch & Fitzgerald, 161 Broadway, N. Y. . . .	5
		<b>Watch Manufacturers.</b>	
		A. C. Smith Watch Co., 177 Broadway. . . . .	54-35
		Trenton Watch Co., Trenton, N. J. . . . .	17
		<b>Watch Case Manufacturers.</b>	
		Wadsworth Watch Case Co., Newport, Ky. . . . .	41
		<b>Watch Case Repairers.</b>	
		The Planchamp & Becker Co., Chicago, Ill. . . .	41
		<b>Watch Importers.</b>	
		Hyde's, J. E., Sons, 22 Maiden Lane, N. Y. . . .	4
		Mathey Bros., Mathez & Co., 21 & 23 Maiden Lane, N. Y. . . . .	53
		Racine, Jules, 180 Broadway, New York. . . . .	55
		Robert, Edmond E., 21 Maiden Lane, N. Y. . . .	14
		A. Wittnauer, 19 Maiden Lane, N. Y. . . . .	33
		<b>Watch Keys.</b>	
		Clark, A. N., Plainville, Conn. . . . .	14



## Special Notices.

Rates 75c. per insertion for notices not exceeding 3 lines (25 words); additional words 2 cents each if answers are to be forwarded, postage stamps must be enclosed. Two insertions, 15 per cent. off; three insertions, 20 per cent. off; four insertions or more, 25 per cent. off. Payable strictly in advance. Display cards on this page will be charged at \$2.00 per inch for first insertion, subject to same discount as above for subsequent insertions.

Under the heading of **Situations Wanted** on this page advertisements will be inserted for **One Cent a Word**. This offer refers to **Situations Wanted only**. Payable strictly in advance. It answers are to be forwarded, postage must be enclosed.

## Situations Wanted.

*Notices under this heading ONLY are charged at one cent a word, payable strictly in advance. If answer are to be forwarded, postage must be enclosed.*

**WANTED**, a position as expert watchmaker. Experience of 20 years of fine and complicated watches. Best of references. Address Adjustino, care JEWELERS' CIRCULAR.

**WANTED**, by a practical jeweler. Experienced foreman and designer, especially diamond work, wishes a position by Jan. 1st. Address A. B., care JEWELERS' CIRCULAR.

**WATCHMAKER** wants situation, eight years' city reference. Moderate salary. Archard, 229 W. 38th St., New York.

**EXPERIENCED TRAVELER** would like to represent an eastern manufacturer, Jan. 1st. Address Traveler, care H. B. Peters, 177 Broadway, New York.

**BOOKKEEPER**, absolutely reliable and competent to take charge of office, credits and collections, desires to make a change: for number of years in similar position in watch and diamond line; excellent references. Address Amiable, 170. Care JEWELERS' CIRCULAR.

**POSITION** desired by young man of good address and ability, where 12 years' business experience and acquaintance with New England, Middle States, and southern jewelry trade will enable him to advance; highest references. W. A. L. S., P. O. Box 1276, New York.

**SALESMAN**; thoroughly acquainted with western jewelry trade, jobbing and retail, wishes to make a change Jan. 1, have been with present house eight [8] years. Address X., JEWELERS' CIRCULAR, 189 Broadway.

**A GRADUATED** optician wishes a position as optician in a jewelry store. Address W. E., care of JEWELERS' CIRCULAR.

**SALESMAN**.—A first-class man, with unquestionable references as to ability, character. &c., direct from one of the largest houses in N. Y. city, desires an engagement to travel in New England, New York city and near-by towns. Would like line of fine gold jewelry or any manufacturer's line. H. J., JEWELERS' CIRCULAR.

**THOROUGH**, energetic, bright business man wants to connect himself with house doing installment business, having done same successfully with 10,000 accounts in his ledger. House appreciating value of such trade will find right man in right place. Address Installment, care of JEWELERS' CIRCULAR.

**THOROUGHLY** competent watchmaker and jeweler wants permanent situation. Married. References A. 1. Also diamond setter and plain engraver. Box 154, Hope, Ark.

**SALESMAN** desires position. Acquainted with dry goods and jewelry trade. Middle and Western States. Address Traveler, care of JEWELERS' CIRCULAR.

**A N** experienced salesman in watches and jewelry wants a position to travel for a jobbing or manufacturing house in New England. Address M. B., care JEWELERS' CIRCULAR.

**WANTED**, a position as salesman, after Jan. 1st, in a wholesale or retail jewelry business, by one who is at present engaged with one of the leading jewelry firms in this city. Best of references given. Address A. A. X., care JEWELERS' CIRCULAR.

**SITUATION WANTED**—I am not a "first class watchmaker, clockmaker, jeweler and engraver," etc., but I am an expert on all kinds of watch repairing. I have had 20 years' experience with some of the best houses in the United States and am fully equipped with all modern tools. I am accustomed to handling first class city trade and competent to take full charge if desired; shall be open for an engagement Dec. 1st; references unexceptionable. Address "Expert," care THE JEWELERS' CIRCULAR.

## Help Wanted.

**WANTED**—Letter engravers on silverware. State experience and wages expected. Address B. C., care JEWELERS' CIRCULAR.

**WANTED**, salesman, thoroughly acquainted with the large retail trade in the East and Middle States. Must be posted in the watch line. Address B. B., care JEWELERS' CIRCULAR.

**FIRST CLASS** designer for manufacturing jeweler in Newark. Address, with references, M. Z., care JEWELERS' CIRCULAR.

**WANTED**, a first-class script and monogram engraver on silver ware and jewelry to go south for the months of December and January. Send specimen of work and state wages wanted. Address Theus Bros., Savannah, Ga.

**WANTED**, good engraver, who can assist watchmaker when not busy engraving, for leading store in the southwest. Address, giving age and salary wanted, S. Charles, P. O., Memphis, Tenn.

## For Sale.

**FOR SALE**—Tools, fixtures and machinery of a manufacturing jeweler; can be seen in working order. Address King & Co., 355 Mulberry St., Newark, N. J.

**FOR SALE**—Long established jewelry and optical business, including stock, safe, fixtures, tools and materials; good run of bench work and jewelry repairing. Address S. A. Patterson, Administrator, Asbury Park, N. J.

## Miscellaneous.

**WATCHMAKING** thoroughly taught by an experienced mechanic. No crowded school; but a limited number taken. Charges reasonable. Actual work. For particulars, &c., address M. E. Harmstead, 709 Sansom St., Philadelphia, Pa.

## To Let.

**TO LET**, at 41 Maiden Lane, a very desirable office, handsomely furnished; electric light and gas. Moderate rent. Inquire at Room 35.

## DIAMOND CUTTING WORKS FOR SALE

12 Mills down-town, most improved, entirely new machinery, good light, could give possession at once. Rent of premises reasonable.

APPLY TO

**THE ARTHUR CO.**

86 John Street, New York.

## WHEEL CUTTING.

We make a specialty of Wheel Cutting, Demagnetizing and Watch Repairing for the trade. Complete plant. Send for price list.  
**THE WINSLOW & PENNEY CO.**  
608 Masonic Temple, CHICAGO.

**H. M. RICH & CO.,**  
**Jewelry • Auctioneers,**  
**21 School Street.**  
**BOSTON, MASS.**



## ELECTRIC TELEPHONE

Sold outright, no rent, no royalty. Adapted to City, Village or Country. Needed in every home, shop, store and office. Greatest convenience and best seller on earth.  
Agents make from \$5 to \$50 per day. One in a residence means a sale to all the neighbors. Fine instruments, no toys, works anywhere, any distance. Complete, ready for use when shipped. Can be put up by any one, never out of order, no repairing, lasts a life time. Warranted. A money maker. Write W. P. Harrison & Co., Clerk 10, Columbus, O.

**BORLOZ FILES.**  
**L. COMBREMONT**  
IMPORTER OF  
**Tools and Materials,**  
45 Maiden Lane, NEW YORK.

**THE OLDEST,**  
Newsiest,  
Most Thorough,  
Most Liberal,  
Best Illustrated,  
Handsomest,  
**THE PAPER.**

**IT PAYS**

**TO KEEP IN TOUCH WITH  
TRADE AFFAIRS.**

**DO SO**

... BY ...

**SUBSCRIBING TO**

**The Jewelers' Circular.**

—◆ 17 Jewel Dueber-Hampden Watches ◆—

ARE THE MOST RELIABLE WATCHES MADE.

A FULL LINE OF DUEBER CASES AND HAMPDEN MOVEMENT.

Write for New Price List.

**Brethauer Watch and Jewelry Co.,** Special Agents,  
71 WASHINGTON ST., CHICAGO, ILLS.

### Boston.

A new watch industry is one of the possibilities of the near future in Waltham. It is said that E. A. Locke will begin the manufacture of a cheap watch at once, as he has the model for the same completed, and everything is in readiness to commence operations.

The Jewelry Travelers' Association of New England has packed its trunk and checked it for Boston. The annual meeting and banquet of the organization will be held at the Quincy House, Friday evening, Dec. 21.

It is stated that the association of retail jewelers now forming in this State will have its headquarters in Boston when the plans are more fully carried out, and dealers in this city shall have been organized by the promoters of the undertaking.

Among the December brides is Mrs. Sumner Wheeler White, of New York, who, previous to Dec. 1st was Miss Frances G. Crosby, of this city. She is the daughter of the late C. A. W. Crosby, for many years one of the best known jewelers in the Hub.

The New England Association of Opticians has appointed a committee to consider the advisability of placing a suitable memorial in Mt. Auburn to mark the last resting place of Robert B. Tolles, the eminent microscopist and representative of their craft, who died in 1883, and whose grave in this famous city of the dead has never been marked by an appropriate tablet. The report of committee is due at the next meeting and is likely to be favorable to the proposed action.

President Samuel Little, of the E. Howard Watch & Clock Co., is one of Boston's busy men. He has just been re-

lected president of the West End Street railway corporation, the big company that provides transit for the million or more inhabitants of greater Boston. Mr. Little is one of the men who know how to direct affairs without trying to do every detail themselves and is very keen and discriminating in his choice of men for positions of responsibility in the various enterprises wherein he is a controlling force.

### Providence.

Frank C. Latham, retailer, 1790 Westminster St., is out of business.

J. Prefontaine has given a chattel mortgage to the Providence Loan Co.

Adolph Lederer is enjoying a short business and pleasure trip in Europe.

J. B. Wentworth is seriously ill with congestion of the lungs and heart trouble.

Albert Holt, who has been seriously ill for several weeks, is still in a precarious condition.

Charles Briggs, of J. Briggs & Sons, returned last week from a two months' trip in Paris.

Frank Cutter, electroplater, has removed from Friendship St. to quarters in the new Kent & Stanley Co. building.

The will of the late Thomas Quayle has been entered for probate in the Municipal Court to be acted upon on the 4th inst.

Frank Chase, manager of the Fall River branch store for James A. Foster & Co., of this city, was in town the past week on business.

Fred. B. Ray has returned from an extended trip through the west and Canada, in the interests of the Darling Smelting and Refining Co.

Cassius M. Seymour, formerly of the

Seymour-Knapp-Warren Co., Plainville, Mass., has accepted a position as traveling representative for Bennett & Melcher, of this city.

Hatch, White & Co. have succeeded Harrington & White, manufacturers, 59 Page St. J. J. Hatch was formerly with D. S. Spaulding, Mansfield, Mass. The new firm will make a line of sterling silver novelties.

William H. Crins, ex-president of the Gorham Mfg. Co., accompanied by his wife and two nieces, sailed Friday on the *Columbia* for San Francisco, Cal. Mr. Crins proposes to visit the various health resorts of southern California.

W. H. Elliott, 18 Broad St., Pawtucket, is making extensive alterations and additions to his store and increasing his stock of silverware and holiday goods. The silverware case that he has put in the rear of the store is very handsome and the mirrors in it improve the appearance of the store.

Thanksgiving was generally observed in this vicinity, all the shops closing down for the day and some for the week. The following firms presented turkeys to the married employes and greenbacks to the unmarried ones: S. B. Champlin & Son, John Austin & Son, J. W. Richardson & Co., A. Holt & Co., Fletcher, Burrows & Co., Hutchison & Huestis, S. K. Merrill & Co., and Fessenden & Co. This is the 31st annual occasion of this custom on the part of J. W. Richardson & Co.

A large portion of the new Kent & Stanley Co. building has already been rented, only about one floor remaining. Among the firms that have taken room are Kent & Stanley Co., Parks Bros. & Rogers, A. T. Wall & Co.; Greene & Knox Mfg. Co.; George H. Cahoon & Co.; Marden &



## SOMETHING NEW !

### Interchangeable Initial Watches.

We have placed on the market a line of "Charmilles" watches cased in steel, black oxydized with GOLD INITIALS in relief. These initials are interchangeable with the backs; are 10 karat gold, cost but little extra, and make

#### A VERY ATTRACTIVE WATCH.

INITIAL watches appeal to public sentiment and taste. The advantages of INTERCHANGEABLE Initial Watches at LOW PRICES will be appreciated by all.

Ask Your Jobber For Them.

A. C. SMITH WATCH CO., - 177 Broadway, New York.

Kettlety and Frank Cutter. Some of these have not yet removed and Parks Bros. & Rogers and A. T. Wall & Co. will not take possession until next March.

The municipal election of Tuesday last was a hotly contested one and a large vote was cast. Several prominent jewelers were personally interested in the outcome, with the following results: Edward G. Burrows was elected by the Republicans Alderman from the 5th ward; Myron G. Fuller in 6th ward was defeated. For Councilmen, George H. Wood was elected from ward 1, William Blakely from ward 4, defeating B. F. Crossin and Leopold Dimond; John L. Remlinger from ward 6 defeating John T. Drinan and Ansel L. Sweet; Horace K. Blanchard and George L. Vose from ward 8. Martin S. Fanning was elected a member of the School Committee from the 9th ward.

**Buffalo.**

E. A. Muth spent Thanksgiving in Newark, N. Y.

William Walther is out again after undergoing an operation at the general hospital.

C. H. Philips, formerly with King & Eisele, has entered the employ of Hoyt & Jackson, Norwalk, O.

L. B. Stevens has left the employ of Schneider & Betz, to take a position with a New York material and tool house.

W. E. Hoffrogge, former bookkeeper for King & Eisele, who had to leave Buffalo on account of ill health, died at his home in Baltimore on Thanksgiving morning.

The following out-of-town jewelers were here last week: J. H. Kaiser, Jamestown, N. Y.; J. A. Stapf, Dunkirk, N. Y.; J. C. Lane, Colden, N. Y.; A. Allen, Silver Creek, N. Y.; J. J. Carr, Suspension Bridge, N. Y.; W. B. Sweet, Angola, N. Y.

The many friends of W. W. Parker, of Parker & Mills, Akron, N. Y., sympathize with him in the loss of his brother, Orlando P. Parker, who was killed here Nov. 26th, as he was running to catch the train to go to work. Mr. Parker was one of the ticket agents for the New York Central Railroad in their main depot.

**Syracuse.**

M. H. Reese will start in business on the 15th inst. at 210 Warren St. He will carry a general line of jewelry and optical goods.

Out-of-town buyers in Syracuse, the past week included: Bert Stoltz, Port Bryon; N. G. Taylor, Weedsport; and Mr. Higgins, of Higgins Bros., Oswego.

**The Latest Patents.**

ISSUE OF NOV. 27, 1894.

**529,743.** BROOCH-PIN. DAVID METZGER, New York, N. Y.—Filed May 9, 1893. Serial No. 473,507. (No model.)



The combination with an ornament, of guides secured to said ornament, two pins each having a longitudinal movement in the same plane relatively to the guides and outside the planes of the guides, each of said pins having a shank portion extended from it through a guide and prolonged to form a handle and stop and an independent spring for each of the pins.

**529,748.** GARMENT FASTENER. ARCHIBALD

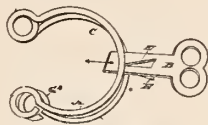

PICKEN, Roanoke, Va.—Filed Nov. 20, 1893. Serial No. 491,508. (No model.)

**529,835.** MUSICAL CLOCK. HENRY W. PORTER, Forestville, Conn., assignor of one-half to

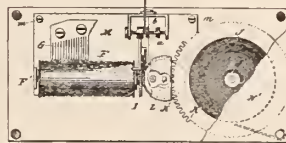
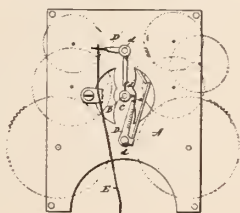

Frederick N. Manross, same place.—Filed Mar. 7, 1893. Renewed Feb. 14, 1894. Serial No. 500,177. (No model.)

**529,988.** DOUBLE EYEGLASSES. JOHN J. WOOD, Liverpool, England.—Filed June 23, 1894. Serial No. 515,636. (No model.) Patented in England Apr. 22, 1893, No. 8,124.

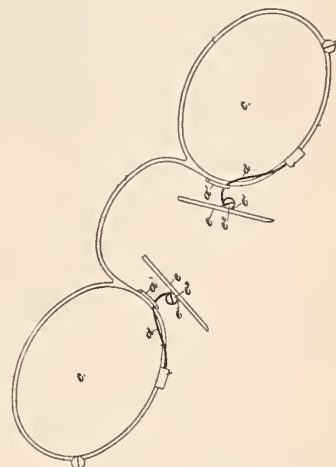

The combination with a spring arm *d* attached to an eyeglass or its frame and adapted to press outward, and a gripping beaver *e* mounted on said spring arm, of a bar extended from the frame or glass and around the outside of said spring arm to shield and protect the arm.

DESIGN **23,816.** BADGE. FRANKLIN ELLIS,



Troy, assignor to the Pettibone Manufacturing Company, Cincinnati, Ohio.—Filed July 23, 1894. Serial No. 518,396. Term of patent 7 years.

**SOUVENIR TRAYS**

FOR CHRISTMAS.

Round or Square, Best Quadruple Plate.

Plain Polish or Plain Satin.....38c. each.

Fancy Initial or Single Name in Script, to order.....48c. each.

WRITE FOR CIRCULARS OF NEW IDEAS IN

PIN TRAYS, INDIVIDUAL BUTTER PLATES, ETC.

Made in Sterling Silver, Quadruple Plate, Plain and Gold Trimmings.

Buy from Manufacturers. We Sell But One Jeweler in Each Town. Secure Control at Once.



**O. E. BELL & CO., Mfgs., Cincinnati, O.**

**H. M. SMITH & CO., MANUFACTURERS,**



**83 NASSAU STREET, - - - NEW YORK CITY.**  
New Catalogue Just Issued.

"THE EMPIRE WESTWARD TAKES ITS WAY"

# WESTERN SUPPLEMENT of THE JEWELERS' CIRCULAR

Chicago Office: Room 517, Inter-Ocean Building.

VOL. XXIX.

CHICAGO, WEDNESDAY, DEC. 5, 1894.

No. 19.

## Chicago Notes.

### TRADE CONDITIONS.

Jobbers of watches report an improvement in distribution over last year.

Sterling silver houses report business very good, with a satisfactory increase for the week.

In clocks there is a good healthy trade with goods of all classes moving well. It would seem business in this line was never so good as just now, and the demand is in excess of the factories' capacity for output.

Business affairs have assumed a nearly normal aspect for the season. Jobbing houses are busy and trade improved quite a little the past week. Leading houses express satisfaction with present trade conditions and say there is no cause for complaint.

Plated houses have been fully employed the past week and in instances have had all they can do to keep up with orders. With the increasing demand houses are running short on quite a good many goods. Factories are forwarding goods to their western houses as fast as there is good reason to expect of them under the circumstances, with every prospect from present demands that there will be an increased shortage before the end of the season.

C. Farr recently opened a jewelry store in Astoria Ill.

M. G. Mohler has removed from Gilman, Ill., to Onarga, Ill.

Arthur E. Bradshaw, of Wm. Bradshaw & Son, Delphi, Ind., made purchases here the past week.

Ritter & Ryan, successors to Ritter & Tenney, Muncie, Ind., were putting in a Fall stock the past week.

The stock of Olson & Co., DeKalb, Ill., was disposed of at sheriff's sale the 10th ult. Chicago dealers were interested.

Ralston & Kessler, who recently bought

out E. R. Biggs, Goshen, Ind., numbered among the buyers in this city last week.

H. A. Gore, a practical watchmaker, formerly with Fox, jeweler, at Lewistown, Ill., has opened a jewelry stand in the stationery store of O. M. Ross, in that city.

Optician Smith, Watkins, N. Y., who has spent a lifetime in the business, is attending the advanced classes of the Chicago Ophthalmic College, 607 W. Van Buren St.

E. W. Leeds, "Get there, Eli," Terre Haute, Ind., was rushing around Chicago jobbing houses last week with his accustomed energy, placing orders for Fall and holiday trade.

James K. Wiggins, son of Jno. B. Wiggins, the well known engraver of this city, has gone to Tehuantepec Bay, on the border between Mexico and Guatemala, to look up investments in coffee plantations.

Among recent removals are noted those of A. E. Baylis, who has left Plainfield, Ill., to open in Chillicothe, Ill., and Wm. Morris, who has changed his address from Darlington, Wis., to Chenoa, Ill., where he opens up a new store.

Nov. 28 the Rogers Park Silverware Co., of Chicago, received their certificate of incorporation. The capital still is \$25,000, and the business to be prosecuted is the manufacture and sale of silverware and the sale of other merchandise. The promoters are E. A. S. Bartelow, Henry N. Frisbie and G. H. Loehr.

Fire has no terror for Illinois jewelers. Among those rising phoenix-like from ashes is Mr. Matthewson, jeweler at Astoria, Ill., who being lately burned out, has built and now occupies his new store there. Also F. L. Kyser, El Paso, Ill., whose place was destroyed by fire in August, opens up with a rebuilt and refitted store.

The meeting of the Chicago Engravers' Association, the new organization of leading

jewelry engravers, scheduled for Dec. 1st, was postponed subject to the call of the president. The engravers are so busily employed at present that night work is the rule and a proper representation at a meeting at this time would entail a pecuniary loss to each member.

Out-of-town dealers represented in Chicago by personal buyers included, last week: B. Schnadig & Co., Cedar Rapids, Ia.; Ralston & Kessler, Goshen, Ind.; Wm. Seewald, Tiffin, Ohio; P. K. Wier, Mankato, Minn.; G. S. Hewitt, Toulon, Ill.; J. F. Cover, Toulon, Ill.; C. K. Charlton, Wilmington, Ill.; W. E. Reed, Kenosha, Wis.; W. J. Welsh, Iowa City, Iowa; Trask & Plain, Galesburg, Ill.; E. W. Kelley, Sullivan, Ind.; Wm. Bradshaw & Son, Delphi, Ind.; A. F. Hall, Janeville, Wis.; H. Applebaum, Lemont, Ill.; A. Buysee, South Bend, Ind.; W. A. Bowen, Kewaunee, Ill.; F. Boszkardt, Kirkland, Ill.; J. Blair, Batavia, Ill.; G. F. Beach, Valparaiso, Ind.; H. H. Bisbee, Ludington, Mich.; G. G. Case, Jackson, Mich.; H. B. Clark, Rantoul, Ill.; W. W. Denny, Aurora, Ill.; H. Jorgenson, West Superior, Wis.; Theodore Dieckman, Sheboygan, Wis.; Eggerman & Son, Aurora, Ill.; Fisher & Bro., Siddell, Ill.; R. O. Gottfredson, Kenosha, Ill.; H. P. Heald, Ravenswood, Ill.; J. F. Ingalls & Son, Waukegan, Ill.; Geo. Kelly, Paw Paw, Ill.; Lundgrun & Wilson, St. Charles, Ill.; F. J. Kempel, Oregon, Ill.; R. N. Lee, Henry, Ill.; M. Luchtemeyer, Blue Island, Ill.; E. C. Long, Shabbona, Ill.; Albert Miller, Dundee, Ill.; Huntley & McLaughlin, Bancroft, Iowa; C. J. Peterson, St. Charles, Ill.; P. Pfeiffer, Lemont, Ill.; W. A. Pratt, Paw Paw, Ill.; Mrs. F. J. Reemer, So. Chicago, Ill.; J. R. Schneider, Evanston; W. H. Stever, Henry, Ill.; Second-Hopkins Co., Kensington, Ill.; Stone & Warden, Albion, Ind.; W. H. Sanders, Kankakee, Ill.; J. Taussig, Hammond, Ind.; R. E. Winter, Highwood, Ill.; A. I. Wyatt, Salt Lake City, Utah; Wilson & Cobb, Yankton, S. D.; W. P. Yeoman, Waukegan, Ill.; George Beemer, Lead City, S. D.

# LOOK AT THESE PRICES!

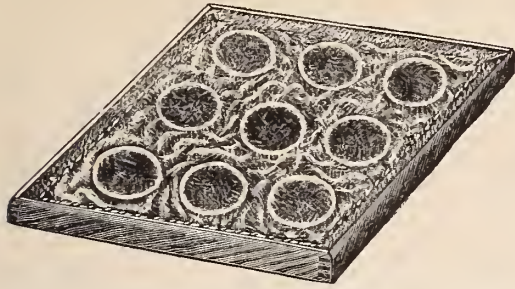

Show Case Trays with Solid Walnut Frames lined with Fine Red Silk Plush, with Old Gold Border, and made to stack one on top of the other. Size, 11 3/4 x 11 3/4.

For Gents' Watches, each . . . . . \$1.25  
For Ladies' Watches, each, . . . . . \$1.25  
For Rings, each . \$1.25. For Chains, each, . \$1.25  
For Charms, ea., \$1.25, for Card Jewelry, plain, ea., 80c.

Subject to the usual discount for cash.

## CHRISTMAS IS COMING.

Make your Stock Attractive and Fresh. It does not cost much and will add largely to your SALES.

## BENJ. ALLEN & Co.,

141 & 143 State St.,  
CHICAGO, ILL.



### FINE PLUSH BOXES.

For Gents' Watches, per dozen, \$3.00 For Ladies' Watches, per dozen, \$3.00  
For Rings, per dozen, \$2.00 For Ear Drops, per dozen, \$3.50  
For Six Tea Spoons, per dozen, \$9.00 For Six Table Spoons, per dozen, \$15.00  
For Child's Set, per dozen, \$9.00 For Six Coffee Spoons, per doz., \$15.00  
For Sugar Shell, per dozen . . \$9.00 For Butter Knife, per dozen . . \$9.00

Subject to the usual discount for cash.



## GENEVA OPTICAL CO., CHICAGO.

### CATALOGUES.

- PART 1—General Catalogue of Optical Goods.
- " 2—Microscopes and Accessories.
- " 3—Photographic Cameras, Stocks and Supplies.
- " 4—Thermometers, Barometers and Meteorological Instruments.

### PRESCRIPTION WORK

Made with Promptness and Accuracy.

### OCULISTS' or OPTICIANS' OUTFITS.

Trial Cases.  
Ophthalmoscopes.  
Lens Measures.

CORRESPONDENCE SOLICITED.

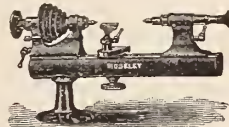

One of the best of the very best.

QUALITY IS THE STANDARD OF VALUE FOR WHICH WE COMPETE

### "THE MOSELEY."

"A Bread Winner" for the watchmaker. We furnish you good lathes and chucks, while the other fellow furnishes the wind.

MOSELEY & CO., Elgin, Ill.



No. 2 Moseley Wire Chuck has length, strength, accuracy.

## PARSONS : SCHOOL —FOR— WATCHMAKERS, PEORIA, ILL.

Send for Circular and Terms.

### PARSONS & CO.

## THE PLANCHAMP & BECKER CO.

Makers and Repairers of

### WATCH CASES, Gold and Silver Plating —

— of Watch Cases a Specialty.

UNEXCELLED FACILITIES.

63 and 65 East Washington St., Chicago.

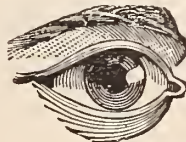

## The St. Louis Ophthalmic College and Hospital

A SCHOOL OF THEORETICAL AND APPLIED OPHTHALMIC OPTICS.

1655 SOUTH JEFFERSON AVENUE,

N. W. Corner Lafayette Avenue, - - - ST. LOUIS, MO.

For the Announcement and further information, address Ignatz Mayer, M. D., President.

# THE WADSWORTH WATCH CASE CO.



774.

General Offices,  
NEWPORT, KY.

Filled



793.

NEW 12 SIZE  
TO FIT ALL 6S. P. S. MOVEMENTS.

Cases.



802.

Chicago Office,  
COLUMBUS BUILDING.

**Cincinnati.**

Baldwin & Martin, Winchester, Ky., are now Baldwin & Bro.

Baker & Worrell, Washington, Pa., are selling out at auction.

S. Lindenberg returned last week from a successful trip. He went out again Monday.

J. Wetherell & Son, Parkersburg, W. Va., have moved into their new and elegant store.

Chas. Stern has recovered from his serious illness and will be down at the store in a week or so.

A. G. Schwab is just home from a short trip. His firm have all the business they can attend to.

Wm. Pfeuger, of Jos. Noterman & Co., is home to stock up and will go out again. He has had a fine trade.

Mrs. Hambrink, a jeweler in a small way, failed Saturday. A few Cincinnati jobbers are interested for small amounts.

C. W. Ernstein, Gallipolis, O., is disposing of his business, and will go to California on account of his wife's ill-health.

Oskamp, Nolting & Co.'s December circular is interesting. It is profusely illustrated and gives good ideas of the very things one needs for the holiday trade.

Messrs. Arthur Daggett, of the Derby Silver Co., Heffron, of Riley, French & Heffron, Fred Kennion, of J. T. Mauran were some of the eastern people in town last week.

Among the visiting trade in town buying goods last week were: W. H. Smith and R. J. Satterthwait, Charleston, W. Va.;

Wm. Keller, of E. C. Barlow, Georgetown, Ky.; Geo. H. Smith, Lancaster, O.

D. Schroder & Co. have a live corps of travelers on the road hustling for diamond trade. The firm are sole agents in this section, south and west, for the celebrated Howard watches, of which they have had remarkable sales.

O. E. Bell & Co. are manufacturing a new line of silver plated novelties, among which are souvenir trays, just the thing for a present; they are made plain, satin finished, engraved with fancy initial or name in script to order.

Harry Walton, of the Wadsworth Watch Case Co., has just returned from a trip east where their new styles are becoming popular sellers. The factory in Newport is running full blast, working nights. Mr. Walton will not go out again, as the company have orders coming in daily for prompt fulfilment.

The permanent representation in New York of Homan & Co. is another plume in the hat of this progressive manufacturing plant. They expect by Jan. 1st to throw open to the eastern trade, one of the most attractive salesrooms on Madison Square, and hope to corral a considerable portion of eastern business. They have long been acknowledged as successful competitors for the western trade and have made rapid strides by important leaders they have turned out for the holiday trade this season. Chas. J. Jacobs, after Jan. 1, 1895, will no longer visit the trade in the east. Robt. Lafferts will manage the firm's New York office with the assistance of Robert W. White. Mr. Jacobs will look after and manage their Chicago office, giving it more of his time and attention in the future. He will also visit their customers in the principal large cities west of Pittsburgh, including that city.

**Minneapolis and St. Paul.**

E. S. Bugbee, Tracy, Minn., commenced an auction sale Dec. 1st, in order to sell off his surplus stock.

A. J. Rost, St. Peter, Minn., was married on the 20th inst. to Miss Minnie Shea, daughter of Mr. and Mrs. D. Shea.

R. L. Davis, lately successor to L. M. Winter, New Richmond, Wis., last week, in a fit of despondency, committed suicide.

Clarence Schleiker, traveling salesman for S. H. Clausin & Co., Minneapolis, returned last week from an extended trip west as far as Seattle, Wash. He reports trade very satisfactory.

A sneak thief opened the show case that stands at the First Ave. entrance to S. E. Olson's store, Minneapolis, Nov. 28, and made away with two watches valued at \$85. The staple which held the lock had been cut.

Out-of-town jewelers visiting the Twin Cities the past week were: A. H. Rent, New Richmond, Wis.; O. C. Field, Rice Lake, Wis.; Lucien Diacon, Chaska, Minn.; L. J. Korstad, Zumbrota, Minn.; A. Hammersten, Cokato, Minn.; M. Kammerer, Arlington, Minn.; H. A. Barreson, Ellsworth, Wis.; A. E. Madsen, North Branch, Minn.; C. J. Meacham, Prescott, Wis., and L. P. Sandberg, Red Wing, Minn.

**Indianapolis.**

Horace A. Comstock is back from a successful hunting expedition.

David J. Reagan spent Thanksgiving with customers in Illinois. He has been sending in very good orders to his house, Baldwin, Miller & Co.

Traveling men were scarce in Indianapolis the past week; the list included: Mr. Smith, Kent & Stanley Co.; I. L. Friedman, Oppenheimer, Zimmern & Co.; Walter Strauss, L. Strauss & Sons; C. O. E. Hartung, Sussfeld, Lorsch & Co.; H. E. Vincent, Simpson, Hall, Miller & Co.; R. Robinson, Green & Knox Mfg. Co.

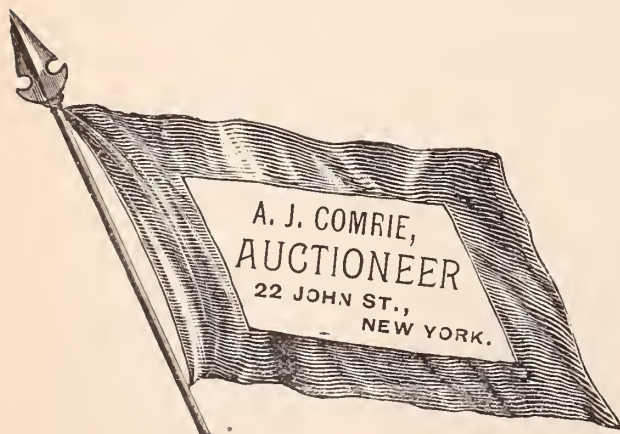

SPECIAL SALESMAN OF  
**WATCHES, DIAMONDS,**  
Bric-a-Brac  
and Art Goods  
FOR  
Established Jewelers.

WRITE FOR PARTICULARS.

Communications Strictly Confidential.

References given in all parts of the United States from Retailers and Jobbers.



**G.A. WEBSTER**  
42 & 44 Madison St., Chicago, Ill.  
**Manufacturer,**  
AND WESTERN AGENT FOR  
E. G. WEBSTER & SON, of Brooklyn, N. Y.  
A. F. TOWLE & SON CO., of Greenfield, Mass.

**D. SCHRODER & CO.,** WHOLESALE JEWELERS  
AND IMPORTERS,



Diamonds, Loose and Mounted at Big Bargain Prices. Sole Agents for West and South of Howard Watches at Greatly Reduced Prices. Send for our Catalogue, it will please you.

252 RACE STREET, CINCINNATI, O.

### Kansas City.

J. R. Mercer is showing one of the finest lines of Austrian glassware in the west.

Dr. Julius King, of the Julius King Optical Co., is in town at present on business connected with his Kansas City branch.

E. A. Reed, of Reed & Barton, was treated very handsomely by the jewelers on his recent visit here and left with a note book full of orders.

The Jaccard Watch & Jewelry Co. have on exhibition in their store a case of secret society jewels which is one of the finest collections ever shown in the city.

Mrs. Harry L. Hobbs, of Colorado Springs, Col., who was formerly head bookkeeper for the Jaccard Watch & Jewelry Co., of this city, is visiting friends here.

T. G. Hawkes & Co. were represented here by W. H. Bryant last week with an elegant line of cut glass. The line this year is by far the best the firm have ever shown.

The following country visitors were in town last week preparing for holiday trade: J. J. Scott, Osawatomie, Kan.; Henry Selts, Clay Center, Kan.; J. B. Lowe, Independence, Mo.; and I. L. Grady, Slater, Mo.

Geo. F. Adams has taken the stock and fixtures recently sold by F. O. Hadley at 918 Main St., and will reopen at the same place. His store is now undergoing extensive repairs and larger show windows are being put in.

Among other things in his window display jeweler C. E. Russell has the prizes for the Midcontinental Poultry Exhibition to be held in this city. The E. E. Shattuck cup, the C. E. Russell cup and the silver Wyandotte cup are very handsome pieces of workmanship.

Burglars pried open a front window at Ben Levin's wholesale jewelry house, 116 W. 6th St., and stole about \$300 worth of jewelry. An inventory of the stock shows that 18 dozen gold plated chains and 7 dozen gold plated rings were taken, besides collar buttons, watch chains and jewelry novelties.

### San Francisco.

Cummings & Sons are conducting an auction sale.

An auction sale is being conducted by Barrett & Sherwood, Montgomery and Bush Sts.

E. J. McMannis, of San Luis, Obispo, and E. Maybem, Chico, were among the trade visitors here last week.

L. Symonds, Point Arena, A. Burnheim, Napa, and H. Wiendieck, Red Bluff, were in town recently buying goods.

Jos. Murphy, formerly with Levison Bros., has returned from the Sandwich Islands. His health necessitates his leaving the jewelry business.

C. Landecker, the Ellis St. jeweler, who failed a short time since and who was closed out at sheriff's sale, is contemplating entering the jobbing business.

Ito Sotomi & Co., the Japanese art and jewelry store, have moved from 4th St. to handsome quarters among the retail shops on Sutter St. between Kearney and Montgomery Sts.

The brownies are having a considerable run in the holiday trade. The *Examiner* wee bears by Swinnerton is another design that if worked up, it is believed, would meet with a great sale here.

Stanley Glidden, formerly traveler for A. I. Hall & Sons, has opened a new jewelry store in the Golden Eagle Hotel, Sacramento. He is a brother of W. B. Glidden, agent for R. Wallace & Sons Mfg. Co.

The failure of J. L. Solomons, who conducts a pawnshop at 622 Kearney St., has proved more extensive than at first reports. It is now stated that his liabilities are from \$60,000 to \$75,000. His principal creditors are eastern houses among whom are mentioned Goodman Bros., New York. M. C. Eppenstein & Co., Chicago, are other large creditors.

### Pacific Coast Notes.

W. Roberts, of Nanaimo, Cal., is selling out at auction.

R. L. Wells has opened a jewelry store in Sprague, Wash.

Chas. Haas, Stockton, Cal., has been in San Francisco buying goods.

The M. A. Rose stock, at Colfax, Wash., is being closed out at auction.

Mr. Lunt, representing the Towle Mfg. Co., is seeing the trade along the coast.

Collingwood's new jewelry store was formally opened in Pasadena, Cal., Nov. 14th.

Davidson Bros., Vancouver, B. C., have given up their retail business and will devote their time to the wholesale trade hereafter.

Jeweler A. P. Tarter, Los Gatos, Cal., is exhibiting the petrified vertebra of an aquatic monster, one joint of which is eight inches long and six inches in circumference.

G. E. Pruner & Co., recently of Fairhaven, Wash., have leased a portion of Geo. W. Donley's new building, in Escondido, Cal., and will soon open with a new stock of jewelry and optical goods.

### Detroit.

Roehm & Son have moved their watch department from the south side to the north side of their store.

C. G. Case and Frank Yerick have started a jewelry store in Jackson, Mich., being located in the Carter block.

George Turner, formerly a jeweler of Chatham, Ont., was in this city last week. He is now with George Chambers, Mt. Clemens.



Our Salesman

# Watch

the results of

# Our Salesman

640 Page Catalogue, 1895,

# Open

On your Show Case.

That will prove his value to you. He does not draw any salary but will double your sales. Open on your show case, as inquisitive people can't help but buy. Bottom prices and special drives are his strongest arguments why you should buy of him.

Send for our 640 Page Illustrated Catalogue if you haven't received it. It's a money maker for you.

OUR NAME DON'T APPEAR IN IT.

# F. M. Sproehne & Co.

103 STATE ST., CHICAGO,

Wholesale Jewelers.

YOU'LL SAVE MONEY

by ordering your Holiday Stock from it.

George W. Crook, jeweler, Trenton, Mich., recently died.

All the jewelers by common consent closed their places of business on Thanksgiving Day.

Burglars last week entered the store of Robinson Bros., Muskegon, Mich., and stole \$50 worth of watches and jewelry.

Sanford Smith, a jeweler, for many years at the corner of 1st St. and Grand River Ave., died last week. He was one of the oldest residents of the city.

Frank Matthauer returned last week from a four weeks' trip through Ohio for Kennedy & Koester. George L. Lowe has started out for the Upper Peninsula.

An auctioneer jewelry store has been opened up for holiday business at Paw Paw, Mich., in the location formerly occupied by R. L. Broughton. M. M. Meyers is the auctioneer.

Joseph M. Ferguson was last week arrested for swindling various merchants by means of bogus checks. Roehm & Son were among the sufferers. The officers took the man over to the Central Police Station, and when they were not looking, Ferguson walked out and has not been seen since.

The Grand Rapids Clock & Mantel Co. have organized. They are not a new concern but a reorganization of the Dryden-Annin-Rose Clock Co., with James T. Phillips as president. Mr. Dryden has retired from the business. The firm will continue the manufacture of fancy hall clocks adding to them the making of artistic mantels.

A furniture wagon last week ran into the show window of Herman H. Idema, Grand Rapids, Mich., and created havoc with the \$5,000 worth of diamonds and watches which he had on exhibition. They were scattered over the sidewalk and became mixed with the broken glass. A large crowd gathered and Mr. Idema alleges that he is out over \$1,000 worth of goods that the crowd picked up. He will endeavor to make the owners of the wagon stand the damage and loss.

Jobbers report a livelier tone in their country trade and the holiday business is expected to start in for good this week. It will probably come with a rush, as retail dealers have been holding off. The following Michigan country jewelers were in the city last week: S. Friedburg, Ann Arbor; S. A. Cleveland, Utica; N. E. Wooten, Milford; L. E. Tobey, Ovid; W. W. Bridges, Marine City; George Hamilton, South Lyons; D. I. Ingles, St. Clair; A. T. Limpricht, Flat Rock; S. O. Ecker, Mt. Clemens; Mr. Hullett, of Hullett & Son, Marshall; W. P. Felt, Belleville; and W. T. Blashill, Oxford.

The Mercantile fountain pen of Aikin, Lambert & Co., 19 Maiden Lane, New York, has met with such great success that the firm are having difficulty in filling all the orders on time.

## Fashions in Holiday Jewelry and Silver Novelties.

A LADY'S RAMBLES AMONG THE JEWELERS.

The collar form of necklace prevails this season, owing doubtless to its greater becomingness.

Black steel watches have a certain vogue. The surface is frequently and effectively studded with tiny diamonds.

Umbrella handles are sword hilt shape, that is to say, flat and slightly concave and overlaid with silver ornaments.

Old Roman coins are mounted as medallions. Another manifestation is designs in metal, with legends in French or Old English.

There have been unusual displays of leather goods during the past week. Soft ivory tones prevail. These goods are bound in silver, frequently touched with enamel.

Large cut glass punch bowls mounted in silver have medallions with engraved ornament in relief. The designs are pertinent to the office of the bowl. They are a decided acquisition.

Medallions of painted ivory, or rather porcelain, are now put on everything that will support such ornamentation. It is suspected that these and the new miniature craze support one another.

Perforated silver standards for tea cups are a recent addition to the equipages for afternoon tea. A lovely set seen had egg shell cups with a pale lavender border above the silver. The effect was exquisite.

The czarina slide goes on conquering and to conquer. The wreath and Italian forms with their foliations, prevail. An exceedingly pretty ornament, used for the same purpose, is the upright bar of gems or rhinestones. At least two of these are essential—one each being placed at the side wings. Occasionally a slide is placed in the center.

ELSIE BEE.

The A. K. Camp Co., Milwaukee, Wis., have gotten out a unique design in the way of a clock case. It was ordered by Louis Allis, one of the proprietors of the big Allis works. Mr. Allis has recently completed a very fine residence, one room of which is finished in natural wood after the manner of a rustic log cabin, and he conceived the idea of hanging a rustic clock of original design on one of the walls. At first he thought to secure a cross section of a petrified tree, using the smooth end for a dial, but found it difficult to carry this out; so an oak tree in its natural state was substituted. The section is about 8 inches in thickness and the end measures about 15 inches across. The wood has been hollowed out from the rear to receive the works and the dial, which is beautifully polished, has

black iron raised figures, in old style design, and the hands are also of black iron. The clock will be suspended from the ceiling by black iron chains.

## Connecticut.

The Bristol Brass & Clock Co., Bristol, are very busy and are running until 9 o'clock each evening.

Major C. H. Case, Hartford, is prominently mentioned for a member of the staff of Gov.-elect Coffin, of Connecticut.

Traveling salesman Capt. M. D. Munson and his son, George D. Munson, of Wallingford, are home from the west to spend the holidays.

Jewelers W. S. & E. H. Rowe, 91 Grand Ave., New Haven, have greatly improved their jewelry store. The improvements include an artistic door sign and a finely lettered sidewalk sign.

Jeweler and optician L. V. B. Hubbard, of Shelton, has re-engaged in his old business. He has re-purchased the business he sold to B. S. Hall and resumed at the old stand. Mr. Hall has not yet decided what business he will engage in.

The Silver Plate Engravers' Union of Meriden, had a grand concert and ball Tuesday night last at the Meriden town hall. The committee in charge were: Walter S. Bagnall, F. W. Hagner, E. Kraemer, G. Schmidt, L. Roselius, H. W. Hugo and C. J. Heineman, Jr.

Geo. H. Wilcox, of the Meriden Britannia Co., was chairman of one of the committees at the banquet given in Meriden Tuesday night last in honor of United States Senators Platt and Dayton, the latter successor to Senator Wilson, of West Virginia. Gilbert Rogers, R. H. Curtis, Samuel Dodd, N. L. Bradley, Walter Hubbard, D. P. Wilcox, G. M. Curtis, C. B. Rogers were members of the committees.

The Parker clock factory, in Coon Hollow, Meriden, will resume operations in a few days after a long shut down. The company have designed a new large pattern clock, that has been put in the market and is meeting with big success. The factory while idle, was remodeled and painted, giving the building an entirely different aspect. When ready to start up, it is expected over one hundred old hands will be given work.

The German silver department at the Meriden Britannia Co.'s shop is the busiest part of the concern at present. The main factory is running ten hours per day, but the German silver department is enabled to work after 6 o'clock, because it is independent of the motive power. Another very encouraging sign of the company's increasing business is shown by the activity of the packing and shipping departments. More goods by far are being shipped this year when compared with last year's holiday business.



## A Pageant of Precious Stones.

NOTHING could have been more brilliant than the recent pageant of precious stones which illuminated the streets of Brussels. The route followed by the novel procession was lined with dense

the whole street broke out into a blaze of multi-colored light. Amid enthusiastic cheers the procession was set in motion.

The first car represented Light, being an appropriate reminder that without the aid of the sun the most brilliant of precious stones would be robbed of its beauty. In a gorgeous chariot, covered with silver and

and the glowing red of the other, together with the artistic grouping of the figures on both, formed pictures of real artistic merit. In each case the colors of the precious stones and their geographical associations were admirably represented.

The topaz, with its figurante in a palanquin, and its attendants flourishing gigantic yellow fans, formed an admirable picture of Asiatic luxury. The turquoise car, with its twenty beauties apparelled in blue, and its floating mass of cerulean bijouterie, was also much admired. A miscellaneous cavalcade, representing jewelry, concluded the procession. For nearly three hours this gorgeous display perambulated the boulevards and principal streets.

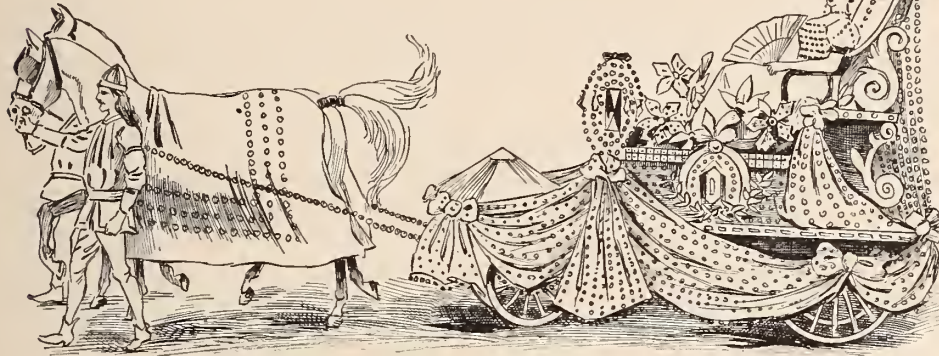

DIAMOND FLOAT, AWARDED THE FIRST PRIZE.

crowds. As night set in the skies were seen to be clouded, and for a moment the weather threatened to put an unceremonious end to the program. A few drops of rain fell, but only to tantalize the spectators, for after a minute or two the downfall ceased. The procession had been formed

blazing with light, the god Phœbus appeared in his most classical form. Follow him was an escort of drummers, musicians and torch bearers, all dressed in white and silver, their tunics and casques ornamented with faceted silver plates.

Then came a troop of cavaliers represent-

**Use of Pegwood.**—In the cleaning of the watch plate the use of the pegwood is a great point. All the sinks and around the jewels should be carefully rubbed; then with a clean dry brush go over the plate once again, and all the time hold the plate between or in a clean sheet of paper. After this has been accomplished to my satisfaction, I commence once more with pegwood, having several pieces, sharpened long not blunt, so it will reach clear though the jewels, and clean and polish them as they should be.

**New Jewel for Balance.**—In setting a new jewel for the balance, if you cannot get a new one to fit, open up the setting of the old and fit in a new jewel. Do it carefully and you will find it as good as if you had a new setting. Select a jewel that is pierced straight through the center. This can be done by fitting the jewel on a piece of wire that is tapered gradually to a fine point. Take a strong glass and examine it and if the jewel is pierced true it will set true on the wire, but if it is down on one side and up on the other it is not pierced true. To fit an American end stone, the cheapest way is to open up the old setting and fit in a new one; the end stone should be tight.

**Conical Pivot.**—If a conical pivot is required, as is usual with most balance staffs, be sure and have it *conical* and not tapered. There is a vast difference in ideas among watch repairers as to what a conical pivot should be. The conical part should take the place of the beveled edge at the root of a square pivot. It should be an easy curve inward till it reaches the pivot itself, which should be perfectly straight and even throughout. When turning it should be left a trifle longer than the jewel hole, and then with the round-edged steel polisher and a little oil-stone dust it should be polished until all graver marks are removed and the proper size obtained. That is, the jewel must fit the pivot without any perceptible side shake, and yet, when the jewel alone is placed in position with the pivot through the hole it should drop off readily when the staff is inverted.



FLOAT EMBLEMATIC OF THE TURQUOISE.

in the Rue Ducale, and there, until nearly 8 o'clock, it remained, a mysterious trail of shadows, the accoutrements of which dimly and mysteriously reflected the flickering lights of the streets. Precisely at 8 o'clock the figurantes lit their torches, the electrical apparatus was set to work and

ing the turquoise, the topaz, the amethyst, the sapphire, the diamond, the emerald and the ruby, serving as a sort of summary of the cars and chariots forming the main body of the procession. Of these cars the most admired were the diamond and ruby. The brilliant white of the one

## MATTERS IN JEWELRY STOREKEEPING.

That this department shall prove mutually beneficial to our readers, it is desirable that the members of the trade generally communicate with THE CIRCULAR regarding any advantageous device or plan that they are utilizing in the conduction of their business.

### The Freezing of Show Windows.

THERE are several recipes recommended for preventing the moistening and freezing of show windows. The first, which is praised as infalible is to dissolve 1½ ounces glycerine in 1 quart 63 per cent. alcohol, to which may be added a little amber oil or other volatile oil. When the mixture has become crystal clear, the inner surface of the show window is, with a piece of wash leather or linen rag, rubbed with it, which prevents not only the freezing, but also the sweating of the window.

The burning of several small gas flames inside on the window sills is also recommended. This prevents the freezing, but not the sweating of the window.

"In the multitude of counsel is wisdom." THE CIRCULAR might just as well trot out the whole of its vast fund of information. It is said that the sweating of the window can be prevented by placing several shallow dishes of quick lime on the sill. The lime naturally absorbs the moisture.

### Jewelers' Window Illumination.

JEWELERS' in Park Row and along the Bowery, New York, have adopted a window illumination that lends greater attractiveness to the rows of diamonds than any number of electric lights. It is a revolving gas jet, with four arms, from the four ends of which the lights stream and whirl. The shifting lights artfully bring out all the power of the gems by repeated reflections from the polished surfaces. A few of these lights are seen in tobacco shop windows, where meerchaum pipes are softer under the glow.

### The Tiffany Blue Book.

TIFFANY'S compact little catalogue, known far and wide as the "Tiffany Blue Book," was out a week earlier than usual this year, and is handsomer and more complete than ever. An effective new cover design, with a rich, deep blue back ground, makes the little volume very attractive. The catalogue is one of the most sought-for of publications of this character issued, as it is a practical catalogue, compact in form and concise in text, with no lavish description, no illustration, and not a superfluous word in the entire 279 pages.

The products of the house in gold and

silver ware, and holiday novelties, are enumerated in alphabetical order, and the range of prices quoted from the minimum upward. The book is sent without charge to any address.

The cover was designed by Paulding Farnham; the die sinking is a fine example of the stage of perfection that has been attained in this department directed by Jas. H. Whitehouse, under whose supervision were also cut the Columbian World's Fair medal and other notable examples of steel die work.

### An Optical Illusion.

WILLIAM M. UPDEGRAVE, optician, Johnstown, Pa., is circulating a little card containing directions for a very neat optical illusion. By gazing intently at a picture of a man's head printed in red on one side of the card, then quickly turning the card over and looking at the back, which is blank, the picture will appear in light blue. It's an illustration of the fact that it isn't best to always believe all you see. The circular is a good advertising dodge.

### A Good and Bad Ad.

HERE is a Providence advertisement that is both good and bad. The printer who set it up was a job

bargain, but the matter is so jumbled up, that it is very hard to read, and one has to look at the advertisement two or threetimes to find out what Whittier & Son are really driving at.

One of the best things that an advertiser can learn, and one of the first things that he ought to learn, is to make his advertisements look readable, and make them really easy to read. Life is too short and people are too busy to waste time on Chinese puzzles in the advertising columns of the paper. The people whom it is most desirable to reach with advertising are busy people, because busy people generally have the wherewithal to purchase the goods advertised. Say what you have to say in as few words as possible and make the advertisement look as readable as possible. When I recommend brevity, I do not mean that the number of words should be cut at the expense of the sense and strength of the advertisement. Use all the words you need to convey your meaning, but do not use any more than that.

### Suggestions for Retail Jewelers' Ads.

ON the opposite page are given a half dozen suggestions for retailers' ads., designed by Charles Austin Bates. They are timely and well worded.

The chryso-ceramics of M. & E. Healy 1122 Connecticut Ave., Washington, D. C., are proving to be a line particularly adaptable for the jewelers' holiday trade. Their gold covered porcelain needs no recommendation to those who have noted its beauties. It was for these products that the manufacturers received the highest award at the World's Columbian Exposition.

<b>H. C. WHITTIER &amp; SON,</b> 327 WESTMINSTER ST., PROVIDENCE, R. I.	
V E R Y	<p>★ TEA ★ SPOONS</p> <p><b>\$7.00</b> PER DOZEN.</p>
Sterling Silver.	
Any Pattern, Style or Design.	
C H E A P	<p>Louis XV., Imperial, Empire, Etc., Etc.</p> <p><b>\$7.00</b> PER DOZEN.</p>

SPECIAL

printer and had no business in a newspaper office. The matter in the ad is all right. It is a plain statement of a plainly apparent

W. C. Kayser, Marshall, Minn., has been conducting an auction clearing sale for the past two weeks,

## SOME IDEAS FOR RETAILERS' ADS.

## THE LIVER OF A WATCH

is the hair spring, and like the human organ it sometimes gets kinks in it—just does all sorts of funny things without any excuse or reason discoverable. It takes a doctor to find out the cause.

We're

### Watch Doctors

and make it our business to straighten out all the little troubles and get the sick watch on its regular diet of time again.—Because you don't understand all the details of a watch, is no excuse for us to charge exorbitant prices for repairing. We charge what it 'is worth, no more.—If your watch is dyspeptic bring it in.

CRYSTAL & CASE,

Wheelburg.

## THERE ARE SOME MEN

who like jewelry—like plenty of it—others again who do not care for it and wear only a little, of a modest sort. Don't matter which way you think, we can please you. A

### Dress Stud

may be anything, from a plain white button to a diamond, the size of small pea. We have both extremes and a big assortment in the middle. Got some collar buttons, too, that, judging from ourselves, you'll like. They do just what they should do and stay where they belong—comfortable, too. We have just put a price on them that's an inducement in itself—solid gold—\$.75; plated, three for \$.50. Want a button?

GOLD & SILVER

Studville.

## THE MODERN HOROLOGIOGRAPHER

smiles as he looks backward at the productions of years ago in the timepiece line. Imagine a watch five inches in diameter! A good watch in the olden times would gain or lose five or ten minutes in a day, depending on the weather.

### A Modern Watch

won't lose or gain this in a year, provided you get the right kind—our kind. We guarantee our watches and know just what they will do. There are no disappointments, lost trains, or broken appointments connected with our chronometers. Not necessary to spend much money either. Our \$28 watch is perfect. Take a minute to call, and gain time.

STEMWOUND & HAND,

Timetown.

## WAIT A MINUTE

But the minute-hand wouldn't wait for the slow-going hour-hand—kept right on going, without any regard for anything, and about noon the clock struck

### Half Past Six.

Ever have one of this sort of clocks—the kind that is forever doing some outrageous sort of thing—a dishonest, irresponsible clock?

Maybe we can fix up the old one—get some conscience into it. If we can't, we'll say so, and then show you a clock that can be depended upon. We have some honest clocks, and they cost so little that you'd be suspicious if we didn't guarantee them. Time's cheap here—good time, too.

PENDLUM & KEY,

Clockville.

## DOWN IN AFRICA

where diamonds grow they don't look for the glittering, dazzling crystals that we know as diamonds—they look for egg-shaped pebbles, common looking stones that do not betray their value.

The cutting of

### A Diamond

brings out the goodness—this work gives it the market value. The way a diamond is cut affects the price almost as much as its degree of whiteness. We make a specialty of selecting only perfect stones. We don't expect our friends to know, except in a general way, about the details—if you do, you'll all the more readily appreciate our stones, and the smallness of our profit.

RING, SET & CO.,

Stonetown.

## THE LITTLE PASTEBOARD

sets you guessing. Your bachelor friend—or may be, girl friend—has informed you through his or her parents, that he or she has decided to step from the field of singles into the meadow of doubles.

Of course, you'll send a

### Wedding Present

but what? After you've pondered and searched for an appropriate mark of your esteem and have arrived at no conclusion, come and see us. Wonderful how well we can guess at what will suit both you and your friends. We have a most beautiful line of suitable presents. What's nicer, what wears better than silverware? Our prices are as low as we can make them—save the worry—save cash, too.

PLATE & STERLING,

Silverton.

## The Treatment of Silver in Melting, &c.

### THE MELTING OF SILVER ALLOYS.

THE processes of melting and properly mixing silver with its alloys in a crucible are among the first operations of the silversmith, and are, moreover, of great importance in the production of intimate and homogenous alloys. In order to effect these, however, simple though they may appear, various precautions are necessary and certain principles require carrying out to arrive at the best possible results, otherwise a great loss or waste of material may take place. To direct attention to those principles, which from very careful attention to the subject we have found to answer best, will first be the aim of these articles.

### PREPARING THE COMPONENTS OF THE ALLOY, ETC.

The weighing of the component metals, the selection of the crucible, the charging of it, and the attention it requires while in the furnace, are considerations to which we can not too strongly call attention. The regulations with regard to weighing should be strictly and accurately carried out. The best and safest plan is, after the various metals have been separately weighed, to re-weigh them, this time collectively, in order to ascertain whether the total weight corresponds with the previous calculation; if it does, the mixture has been properly prepared. We have known both time and trouble saved by the adoption of this precaution, after mistakes had occurred which could not have been detected until the weighing of the bar of metal had taken place after melting.

### CHOICE OF CRUCIBLES.

There are various kinds of crucibles manufactured for the use of the precious metal workers. Crucibles were so-called from originally being stamped by the alchemists with the sign of the cross. They are calculated to bear very high temperature, and consist of English, Hessian, Cornish black lead, and plumbago. The last two are by far the best; the plumbago, however, being the hardest, and capable of withstand-

ing the highest temperatures, it is to be preferred before all others. It will also stand more frequent meltings than any of the others. Such crucibles have been known to withstand the heat of the furnace for upward fifty times, without giving way. The wear of them is very strong and resisting, as they only *gradually* become reduced in thickness, so that it is easy to distinguish their unfitness for use. Fluxes act on earthen crucibles, particularly English, at a high temperature, and niter and carbonate of soda soon destroy them.

### FLUXES.

Fluxes are necessary in most cases of metallic reductions; they protect the metal from the air, and dissolve impurities. They are of several kinds, as follows:

Vegetable charcoal;	Sandiner;
Carbonate of potash;	Yellow soap;
Carbonate of soda;	Black flux;
Common salt;	White flux;
Sal-ammoniac;	Crude tartar;
Sal-enixum;	Brown potash;
Saltpetre;	Sub-carbonate of pot-
Borax;	ash.

All these fluxes have occasional duties to perform, and are therefore of great service to the metallurgist.

### THE DIFFERENT ALLOYING METALS.

When copper and silver only form the alloy of the silversmith, they should both be added to the crucible at the commencement of the operation; and it is the best plan to put the copper at the bottom, because it is the most infusible metal. By doing so it will receive the greatest degree of heat, which in jewelers' furnaces always comes upward, and the higher specific gravity of the silver has a tendency to force that metal downward; consequently, when the two metals have become fused, upon well stirring—which should be done with an iron stirrer tapered at the point, and previously heated to redness—a perfectly homogeneous mass will be the result. When the more fusible metals are to form the component parts of the mixture, different treatment in regard to them will be required. They should not be added at the commencement of the operation, but

should be dealt with afterward, in the following manner:

### ZINC.

Zinc is one of the more fusible metals and is sometimes employed by the silversmith in his alloys, for the purpose of imparting a greater degree of whiteness to them, as well as rendering inferior silver more easily bleached or whitened; thus assisting to bring back the natural color of fine silver to manufactured articles, which have partially lost it by the addition of alloy of some other color. Zinc when employed in silver alloys, should be cautiously used, and care should be taken not to add too much to a given quantity of material. The solder used with silver-zinc alloys should be far more fusible than that employed with the other alloys. If too much zinc be added in the preparation of these alloys, in the course of the work, particularly in the process of soldering, they have a tendency to *sweat* and sometimes to *eat* the metals into holes around the parts to be united; such alloys, therefore, render this process very difficult to perform, beside entailing more labor in the production of a clean and smooth finish.

### ALLOYS OF MORE THAN TWO METALS.

In melting an alloy of silver, copper and zinc, the silver and copper should first be melted in a plumbago crucible, and well stirred together in order that they may become properly mixed. The zinc is sold in flat cakes, generally under the name of "spelter," and, when required, is usually cut up with a chisel into pieces of various weights suitable for the object in view. When the copper and silver have become well incorporated, the mixture should be protected from the air by a suitable flux, charcoal being the best for this purpose. The most suitable time to add it to the crucible in the furnace is when the metals are just beginning to fuse. This flux covers the whole of the surface of the molten mass, and so prevents the action of the air from destroying some of the baser metals. The charcoal should be perfectly pure and in a finely divided state, for if adulterated with any gritty matter (and sometimes such is the case) a very indifferent working material is produced, the evil results of which show themselves in every stage of manufacture. These instructions with regard to melting the more infusible metals having been carried out, the zinc is taken with a long pair of tongs, and held within the furnace, over the mouth of the crucible, until the temperature has almost reached the melting point, when it should be carefully dropped into the fused mass below, quickly stirred, so that it may become intimately mixed with the other metals, and at once withdrawn from the furnace, and poured into a suitable ingot mould.

(To be continued.)

In a fire in Sheffield, Ia., some days ago, the business of Wm. Bird was totally burned out.





HIGHEST  
AWARD  
WORLD'S  
COLUMBIAN  
EXPOSITION.

# RUDOLSTADT

## ART POTTERY.

CONTAINS all the elements re-  
quired as to designs, deco-  
rations and workmanship, in a high  
grade of Art Goods adapted to the  
Jewelry Trade, and yields a larger  
margin of profit than any other  
class of Pottery.

**L. Straus & Sons,**

SOLE AGENTS,  
42-44-46-48 Warren Street,  
116 Chambers Street,  
NEW YORK.



**..THE LATEST..**  
Sterling Silver Novelty,  
**CIGAR CUTTER**  
AND **KEY RING** COMBINED.  
Patented Nov. 20th, 1894.  
WITH OR WITHOUT CHAIN.

MADE ONLY BY  
**ENOS RICHARDSON & CO.,**  
23 Maiden Lane, New York.

## CAMPBELL-METCALF SILVER CO.

FACTORY:  
STEWART ST.,  
PROV., R. I.  
N. Y. OFFICE:  
2 MAIDEN LANE.  
SAN FRANCISCO:  
112 KEARNY ST.

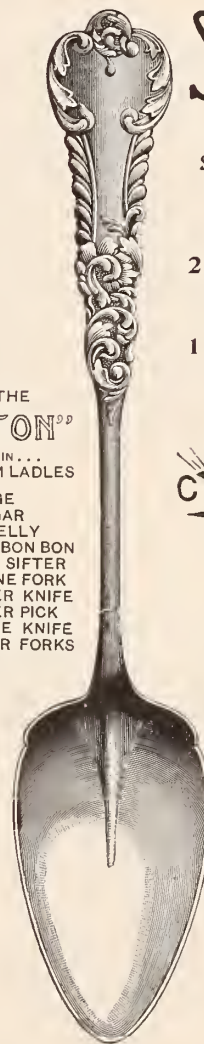

THE  
"ETON"  
... IN ...  
CREAM LADLES  
ORANGE  
SUGAR  
JELLY  
BON BON  
SUGAR SIFTER  
SARDINE FORK  
BUTTER KNIFE  
BUTTER PICK  
CHEESE KNIFE  
OYSTER FORKS  
ETC.



OUR  
"ETON"  
AND  
"STUART"  
PATTERNS  
ARE IMMENSELY  
POPULAR  
AND SELL AT SIGHT  
WRITE DIRECT  
TO FACTORY FOR  
SAMPLES  
AND PRICES.

## FANCY

.. IN ..

SCARF PINS

AND LINKS.



## FIGURES

STERLING SILVER,

Enameled in Colors.

Dudes, Chinamen, Policemen, Sailors, Orators, Cadets, and all other Shapes Made.

SEND FOR SAMPLES.

QUICK SELLERS.

If your Stock does not include our **COLCONDA GEM** Line you are losing sales. This Stone is Mounted in Studs, Scarf Pins, etc., in Solid Gold and Plate.

If your jobber doesn't keep these goods write us and we will send you the address of a jobber in your vicinity who does. Every card bears the words "THE GOI CONDA GEM, Reg'd." all others said to be "equally as good" are spurious. Bear this fact in mind.

**R. L. GRIFFITH & SON, = PROVIDENCE, R. I.**

**\$3.00**

**FORMERLY**

**\$6.00**

Ivory and  
Enamel  
Miniatures

Best  
Workmanship.



Original  
Inventor and  
Patentee of  
**Miniatures**  
—OR—  
**Gold and  
Silver.**

PATENTED  
November 12, 1889

**LEON FAVRE, 107 EAST 26TH STREET,  
NEW YORK.**



# FERDINAND BING & CO.,

106 GRAND ST., N. Y.

NEW DESIGNS IN —————

China Clocks and Gilt Bronze Sets, Fine Painted  
 Dresden Goods in Vases, Cups and Saucers, and Plates;  
 Cararra Marble Statuary, French Cabinets and other  
 Fancy Furniture.

## A. J. HEDGES & CO.,

MANUFACTURERS OF

Gold, Variegated and Enameled Jewelry.

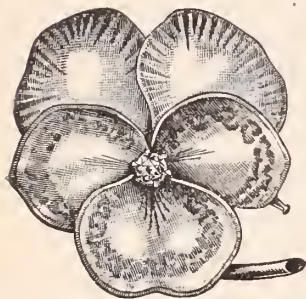

BLACK AND WHITE ENAMELED GOODS  
 — A SPECIALTY. —

SIDE COMBS AND COLLARETTES, LACE PINS, SCARF PINS,  
 BROOCHES AND PENDANTS, CHATELAINES AND  
 BRACELETS, LINK BUTTONS AND STUDS, LADIES'  
 AND GENTLEMEN'S GOLD AND SILVER GARTERS.

FACTORY:  
 90 Mechanic St., Newark, N. J.

6 Maiden Lane, New York.

**Larter, Elcox & Co.**  
 Manufacturers of Fine Gold Jewelry  
 21 & 23 Maiden Lane, New York.

The Attention of the Trade is called to Our Line of . . .

### GENTLEMEN'S RINGS AND SEALS,

with Intaglios, in Jade, Jasper and Carnelian. These goods are exceedingly desirable for this season's trade.

ALSO our full line of Misses' and Children's Rings finished in Roman.

See also our large line of Low Priced Link Buttons, in Solid Gold.

Our Spring Back Studs, improved in construction, are now as near perfect as can be, and never so complete in variety of patterns.



BUY ONLY THE L. E. & CO. STUD.

SELECTION OF STUDS SENT ON APPLICATION.

## A RICH COMBINATION.



Cut Glass Bowl on Artistic Solid Cast Brass Base, Finished in Matt and Burnished Gold.

The Combination of Gold and Cut Glass shown above was a most daring one. Its INSTANT and INCREASING SUCCESS is a proof that the trade appreciates it as a SELLER. Write us at once for full particulars and prices if you are not carrying it.

A Specially Good Thing for Jewelers.

**T. B. CLARK & CO., Inc.,**  
 860 Broadway, N. Y.,

Factories, HONSDALE, PA.

N. E. Cor. 17th St. & Broadway



### The Rambler's Notes.

WHAT THE RAMBLER SAW AND HEARD AMONG THE DEALERS IN ART POTTERY, CUT GLASS, BRONZES, ETC.

**FRENCH PORCELAIN NOVELTIES.** THE three illustrations taken at random from the extensive assortment of French novelties shown by P. H. Leonard, 78 Reade St., New York, will serve to give an idea of the richness of this beautiful line. The Foster shape illustrated in this column Nov. 7th, is here shown again in a salad bowl; a piece the grace and beauty of whose outline are notable. In the handled olive dishes none



FOSTER SALAD BOWL.



TROCADERO OLIVE.



COQUILLE A. D. COFFEE.

are more attractive than the Trocadero, here shown, which displays many colors and decorations with borders of shaded gold on either a satin or glazed finished body. The dainty Coquille after-dinner coffee cup, which gets its name from the shell it resembles is but one of over a hundred new shapes introduced, all of which are shown in various decorations.

\*

THE BEAUTIFUL CROWN-PAIRPOINT.

A GROUP of pieces in the beautiful new ware, Crown-Pairpoint, recently introduced by the Pair-

point Mfg. Co., New Bedford, Mass., is shown in the illustration herewith. The blanks are imported Limoges china, and

There are also many reproductions of famous old styles of mugs. Many are shown with silver or silver rimmed tops.



GROUP OF CROWN-PAIRPOINT WARE.

are decorated at this company's factory by some of the best American artists, the decorations being after the popular American ideals. An advantage residing in this line is that any of the pieces can be duplicated in a few weeks at the outside.

\*

BEER MUGS AND TANKARDS.

AMONG the many lines suitable for holiday presents shown in the warerooms of Chas. Ahrenfeldt & Son, 52 Murray St., New York, beer mugs and tankards are conspicuous. The collection which they show is both rich and extensive and includes mainly Delft and German wares, ranging in size from the small 3 inch mugs to the large 20 inch tankards. The decorations are varied, including the plain blue with or without inscription, while others have figures or inscriptions or both in colors.

AN INNOVATION IN CLOCK CASES.

AN innovation in clocks is promised by the F. Kroeber Clock Co., 360 Broadway, New York, the introducers of the Porcelene clocks which have become so popular. About Feb. 1st next the company expect to bring out a full line of clocks in an entirely new material, a discovery of their own, and which they expect will supersede iron in clock case manufacture. Mantel clocks, which will be the first introduced, will be shown in all sizes and colors. An advantage which the manufacturers claim for these new clocks is that while they will be even more striking in appearance than former lines, they will be quite inexpensive, cheaper in fact than iron clocks of the same quality.

THE RAMBLER.

Silver process work prevails on everything to which it is possible to apply it. Silver on white, it is noticed, is more artistic in effect than on colors.

## The Connoisseur.

(Continued from page 51.)

### The Effects of the New Tariff.

RECENT advices from New York state that the wholesale crockery and glass dealers announce that their business has greatly increased since the passage of the Tariff law. The tax on china, porcelain, earthen ware and stone ware has been very high and its reduction has stimulated trade. Retail dealers and householders are filling up their depelted stocks. Under the law there is no discrimination between china, porcelain, parian and bisque, and common stoneware. Under the McKinley Act the ornamented ware paid 60 per cent., the unornamented 55 per cent. Under the new law they pay respectively 35 and 30 per cent. The price of an ordinary dinner set that could have been bought in Germany for 40s, was increased by the McKinley Act to 63s. Under the new law the saving will be 8s. An ornamented dinner set worth 100l. at Dresden was worth in New York, by reason of the McKinley tariff, not counting cost of transportation, insurance and immediate profits, 160l. Under the new law the saving on such a set will be 25l. The duty on glass has been reduced from 60 to 40 per cent., a saving of one-third, so that glassware which

cost 10l. under McKinleyism would have paid 6l. duty, while now it will pay 4l.—*Pottery Gazette*, (London).

### Points of Law.

The Supreme Court of Mississippi holds that the maker of a note, the consideration for which has failed, is not bound to pay it because he secures an extension thereof from the indorsee, if he makes no promise to pay it in order to obtain the extension.

*Merchants' & Planters' Bank v. Millsapa.*

#### BONA FIDE PURCHASE OF NOTE.

A person for whom a note is indorsed as security for an undertaking entered into at the time of the pledge is a bona fide purchaser. And the fact that the payee of a note which was delivered to him by the maker for the purpose of procuring a loan for the maker diverts it to his own use does not invalidate the note in the hands of a bona fide purchaser.

*Peters v. Gay*, (*Supreme Court of Washington*).

#### SETTLEMENT AND ACCOUNTING OF PARTNERSHIP.

Where partners make a settlement and division of their affairs subject to correction for errors committed, the settlement is final, and a bill to enforce such correction

is one to sur-charge and falsify which must clearly allege the particular mistakes relied on, and be sustained by clear proof. There is no such fiduciary relation between partners as to make a settlement between them any the less binding than those of other people.

*Scheuer v. Berringer*, (*Supreme Court of Alabama*).

#### RIGHT TO PREFER CREDITOR.

An insolvent may prefer a creditor by sale of goods in payment of a pre-existing debt, though they know it will prevent other creditors from collecting their debt; the only condition being that the debt be bona fide, that the goods be taken at a fair and adequate price, and that no benefit be reserved in behalf of the creditor.

*Rates v. Vandiver*, (*Supreme Court of Alabama*).

#### USAGE AS TO COMMERCIAL DESIGNATIONS.

Usage sufficient to establish a commercial designation, which will control the meaning of words in a tariff act cannot be made out by the evidence of one dealer whose testimony is practically limited by his own usage especially when he admits that the articles are sometimes bought and sold under other names.

*Beren becher v. Robertson*, (*Supreme Court of the United States*).

# HOLIDAY COLLECTION FOR THE TRADE.

## ORDER ONE.

### NOVELTIES

... FOR THE ...

## JEWELRY • TRADE.



THE FOSTER PATTERN.



RICHFIELD PATTERN.



THE ROSE PATTERN.

Our \$75 assortments are a Specialty and form a complete collection.

P. H. LEONARD, 76 & 78 Reade Street, NEW YORK.



# CARBORUNDUM.

## Net Retail Price List of Carborundum Wheels.

ACLESON'S PATENT, February 28th, 1893.

Hones, Slabs, Files.

Cut = This = Out.

Diam. in Inches	THICKNESS IN INCHES.																Rev. per Minute.	
	1/4	3/8	1/2	5/8	3/4	7/8	1	1 1/4	1 1/2	1 3/4	2	2 1/4	2 1/2	2 3/4	3	3 1/2		4
1	\$.15	\$.18	\$.20	\$.23	\$.25	\$.28	\$.30	\$.35	\$.40	\$.45	\$.50	\$.55	\$.61	\$.65	\$.70	\$.80	\$.90	18,000
1 1/2	.18	.22	.25	.28	.31	.33	.35	.40	.45	.50	.56	.62	.67	.73	.78	.90	1.00	14,000
2	.20	.25	.30	.34	.37	.40	.42	.46	.52	.58	.65	.70	.77	.85	.91	1.00	1.20	11,000
2 1/2	.25	.30	.37	.42	.46	.48	.50	.55	.60	.67	.75	.80	.91	.98	1.05	1.20	1.40	8,800
3	.30	.38	.45	.50	.55	.58	.60	.65	.70	.78	.85	.95	1.05	1.15	1.25	1.45	1.65	7,400
4	.65	.70	.75	.80	.85	.90	.95	1.10	1.30	1.50	1.65	1.80	2.00	2.15	2.35	2.70	3.05	5,500
5	.85	.90	.95	1.05	1.15	1.25	1.35	1.65	1.90	2.20	2.45	2.75	3.05	3.30	3.55	4.15	4.65	4,400
6	1.10	1.20	1.25	1.45	1.60	1.80	1.95	2.31	2.75	3.15	3.55	3.95	4.33	4.75	5.15	5.95	6.75	3,700
7	1.35	1.55	1.70	1.90	2.10	2.35	2.60	3.15	3.70	4.25	4.80	5.35	5.75	6.45	7.00	8.10	9.20	3,160
8	1.65	1.90	2.15	2.45	2.75	3.05	3.35	4.05	4.80	5.50	6.25	6.95	7.65	8.35	9.10	10.50	12.00	2,750
9	2.00	2.40	2.65	3.10	3.40	3.80	4.15	5.10	5.45	6.90	7.80	8.75	9.65	10.55	11.45	13.25	15.10	2,450
10	2.45	2.80	3.25	3.70	4.15	4.65	5.10	6.25	7.40	8.50	9.60	10.70	11.85	12.90	14.05	16.30	18.55	2,200
12	3.60	4.00	4.40	5.10	5.80	6.50	7.20	8.80	10.40	12.00	14.60	15.20	16.80	18.40	20.00	24.55	26.40	1,830

CARBORUNDUM was awarded both a Medal and a Diploma at the World's Columbian Exposition in recognition of its merits as an Abrasive, the hardness being greater than any other abrasive material. The wheels are made with a vitrified bond, and pressed under hydraulic pressure. Those over three inches in diameter are turned up after firing. The same numbers are used to designate the degrees of fineness, as are used with Emery, and the wheels are made in seven degrees of hardness, marked SSS, SS, S, M, H, HH, HHH, from extremely soft to extremely hard. In ordering, state diameter, thickness, hole, number and hardness.

Monongahela, Pa., U. S. A.

THE CARBORUNDUM COMPANY.

## BOYLE, DAVIS & GOODMAN,

SPECIAL AUCTIONEERS for the Legitimate Trade only.

68 Fifth Avenue  
NEW YORK.

611 Pennsylvania Ave.,  
WASHINGTON, D. C.



S. A. BOYLE.



W. M. DAVIS.



CHAS. P. GOODMAN.

WE PAY ALL OUR OWN EXPENSES. GUARANTEE TO MAKE YOUR SALE WITHOUT LOSS.

SEND FOR OUR BUSINESS PAMPHLET.

CONSULT US BEFORE PLACING YOUR SALE. ADDRESS ALL CORRESPONDENCE TO OUR WASHINGTON OFFICE.

## MATHEY BROS., MATHEZ & CO.

21 & 23 MAIDEN LANE, N. Y.  
BRASSUS, SWITZERLAND.

MANUFACTURERS OF  
THE SMALLEST,  
THE THINNEST,  
THE NEATEST AND  
THE BEST

**SPLITS.**

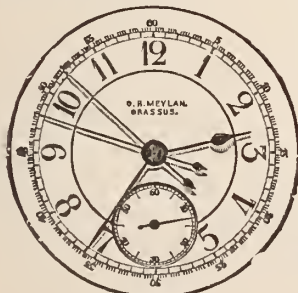

10 Size.



10 Size.

SOLE AGENTS FOR

JAUQUES • LECOULTRE • RAZORS.

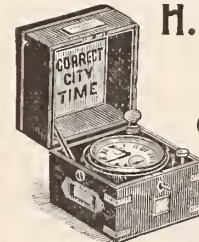

H. H. HEINRICH,

14 John St., N. Y.

MARINE

Chronometers

for Rent and Sale.

Large Stock on Hand.

Springing, Readjusting and  
Repairing for the trade.

Easy Terms. Send for Price List.

WOOD & HUGHES,  
STERLING SILVERWARE MANUFACTURERS

New York Agents for the Derby Silver Co.

FINE QUADRUPLE PLATED WARE,

No. 16 JOHN STREET, NEW YORK.

206 Kearney St., San Francisco, Cal.

HASKELL & MUEGGE, Agents.

## If You are In business For Profits

You should sell  
the new

### "Princeton" Watch

and not be obliged to  
compete with outsiders  
nor have your customers  
tell you prices.

### Three grades:

16 size Nickel, Hunting  
and Open Face—15, 16  
and 17 Jewels, Adjusted,  
Patent Regulator.

Superior to any,  
and at less price.

### Ask your Jobber.

Price Lists with full  
information mailed to  
regular jewelers upon  
application.

A. C. SMITH WATCH CO.,  
Manufacturers,  
177 BROADWAY, - NEW YORK.

### Why the Jeweler Lost Interest in Reform.

THREE or four years ago the chief orator at all gatherings of social reformers in Washington was a well-read and intellectually keen jeweler, writes the Washington correspondent of the *St. Louis Globe-Democrat*. It doesn't matter what the name was. This man worked for wages in one of the principal jewelry stores on Pennsylvania Ave. He received good pay. He was accounted the best watch repairer in the city. The most delicate jobs which came into the shop were turned over to him by common consent. But to the restless mind of the journeyman jeweler the times were sadly out of joint. He followed the proceedings of Congress. He was up on all the Government was doing. He was full of ideas for the betterment of mankind through social reforms. No gathering of theorists was complete without this man. Such was his fluency of speech, that he became the oratorical leader of the socialistic element, which is larger in Washington than the rest of the country generally supposes. At the zenith of his power of leadership the jeweler left his employer on the avenue and opened a little watch repairing shop of his own on a side street. Business prospered with him. He had more work than he could attend to, and became an employer. He bought a little piece of property in suburbs. His name disap-

peared from the newspaper reports of the meetings of the reformers. His old associates lost sight of the smooth spoken journeyman who had so often fired their minds with talks on the wrongs of the masses.

The other day a newspaper man who had listened often to the impassioned words of the socialist passed in front of the shop on the side street. The proprietor stood in the door. Stopping, and replying to the nod of recognition, the newspaper man said to him:

"You look like a bourgeois."

The jeweler flushed a little and smiled. A few questions brought on a narrative of his prosperity since he had established himself. With a little encouragement he told the story of his modest ventures as a property holder.

"How is it," was asked, "that you are never seen at the meetings of the reformers—you, who used to be the most faithful in attendance and always ready to say something?"

The jeweler smiled faintly and flushed again, as he replied:

"I don't feel the interest in those things that I did."

"See here, Johnson, this clock of yours is three hours slow."

"Not so, my boy. That clock is twenty-one hours fast. It wouldn't go for a while, and I had it fixed. Its making up for lost time.—*Harper's Bazar*.

## Now that we have touched bottom

And business generally is improving every GOOD RETAIL JEWELER should make his stock attractive and so invite customers. He can buy nothing more sure of sale than

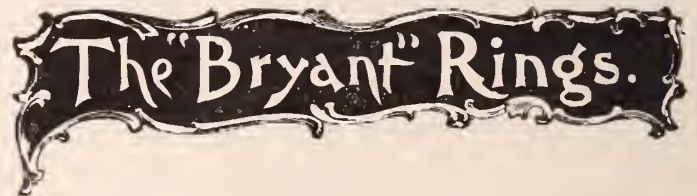

of standard quality, at moderate cost, and of new and taking styles. If not called upon by our travelers send your orders direct to

**M. B. BRYANT & CO.,**  
10 MAIDEN LANE, NEW YORK.

JACOT & SON  
IMPORTERS AND  
MANUFACTURERS  
OF  
MUSICAL BOXES  
39  
Union Sq.  
New York.

### Philadelphia College of Horology

Is not the largest but is the finest school in the country. A practical school to learn watch-making, engraving, and jewelry repairing. One tuition pays for all branches. Send for prospectus.

F. W. SCHULER, PRINCIPAL.  
1213 Filbert St., Philadelphia, Pa.  
Write for particulars of our corresponding course.

### For BADGES and MEDALS,

Flag Pins, Class Pins, Class Rings  
and Special Work of all Descriptions,  
SEND TO E. R. STOCKWELL, MANUF'R,  
19 John Street, New York.

## AIKIN, LAMBERT & CO.,

CHICAGO BRANCH: 103 State Street.

No. 19 MAIDEN LANE, NEW YORK.

Manufacturers and Exporters  
Gold Pens, Holders, Pencils,



Toothpicks and Novelties.

MERCANTILE



FOUNTAIN PEN.

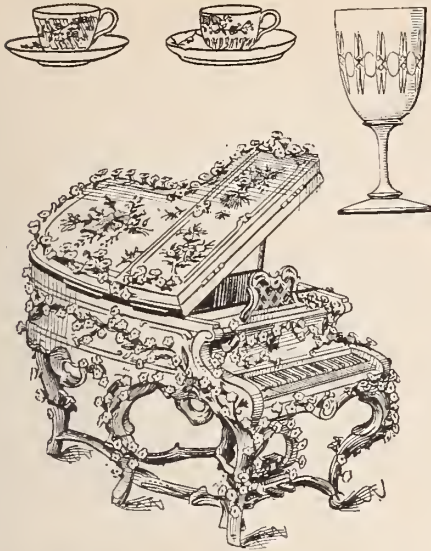

# HINRICHS & CO.,

29 & 31 Park Place, N. Y.

## HOLIDAY GOODS FOR JEWELERS.

ITALIAN MARBLE BUSTS,  
 PARIAN BUSTS and FIGURES,  
 BISQUE FIGURES and GROUPS,  
 FRENCH CHINA CRACKER JARS,  
 CHOCOLATE POTS, TRAYS, BOWLS,  
 SOUVENIR A. D. COFFEES, TEAS, Etc.

ST. GERMAIN AND GERMAN-AMERICAN STUDENT LAMPS.

## BRIC-A-BRAC AND ART POTTERY.

SEND FOR CATALOGUES.



## TOWLE MFG. CO.,

# SILVERSMITHS,

NEWBURYPORT, MASS.

149-157 State St., Chicago, Ill.

## BURGLARY INSURANCE.

## Fidelity and Casualty Co.

OF NEW YORK

INSURES Safes and their Contents

## Against Burglary.

For Particulars, address the Company,  
 40-146 BROADWAY, NEW YORK.

# The Best Chatelaine is the Lady Racine.

## STEEL CASES & SILVER CASES.



10 LINE.

Made in 10 Line Open Face.

“ 11½ Line Open Face and Hunting.

“ 13 Line Open Face and Hunting.

THE SILVER CASES ARE 0.935 FINE.  
 THE MOVEMENTS HAVE 10 JEWELS  
 THE ENGRAVINGS ARE CHOICE.



3 LINE

## MADE IN 12 LINE OPEN FACE.

In Silver Cases only.

Case 0.800 Fine with a 6 Jewel Movement.

Expressly Gotten Up to Suit the Times.



12 LINE

## A GOOD Chatelaine Watch at a LOW PRICE.

Do not fail to ASK YOUR JOBBER FOR THE NEW  
 12 LINE LADY RACINE in 0.800 Cases.

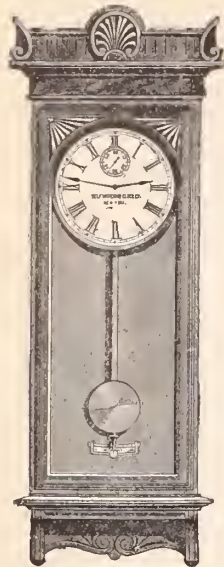

**SELF WINDING CLOCK CO.**

NEW YORK-CHICAGO.

**HALL CLOCKS,  
OFFICE CLOCKS,  
Synchronized Time Plants.**

No Winding. Corrected Hourly

BY TELEGRAPH SIGNALS OVER WESTERN UNION TEL. CO.

Wires from U. S. Naval Observatory, Washington, D. C.

General Office:  
26 BROADWAY, N. Y.

Branch Office:  
Columbus Memorial Bldg, Chicago.



**REORGANIZATION SALE OF  
Opera and Field Glasses.**

We have for immediate sale the largest and best selected stock of Opera and Field Glasses in this country, and offer them at fully 25 per cent. below cost. A few specimen items:

- 75 Non-Achromatic Field Glasses**, 24 lines objective, in case,  
REGULAR PRICE, \$3.25, REDUCED TO..... \$2.00
- 50 Colmont Field Glasses**, 26 lines objective, in case,  
REGULAR PRICE, \$6.00, REDUCED TO..... \$4.90
- 85 Non-Achromatic Opera Glasses**, 15 lines objective, in case,  
REGULAR PRICE, \$9.00 per doz., REDUCED TO..... \$5.25 per dozen
- 50 Achromatic Opera Glasses**, leather covered and japanned, 15 lines objective, in case,  
REGULAR PRICE, \$1.75 each, REDUCED TO..... \$1.35 each.
- 50 Achromatic Opera Glasses**, leather covered and japanned, finer quality, 12 lines objective, in pocket book case, REGULAR PRICE, \$2.25 each, REDUCED TO..... \$1.55 each.
- 40 Achromatic Opera Glasses**, pearl covered, 15 lines objective, in case,  
REGULAR PRICE, \$3.75 each, REDUCED TO..... \$2.90 each.
- 36 Achromatic Opera Glasses**, pearl covered, 17 lines objective in case,  
REGULAR PRICE, \$4.50 each, REDUCED TO..... \$3.70 each

SEND FOR SAMPLES.

**QUEEN & CO., Opticians,**

J. G. GRAY, Assignee.

1010 Chestnut St., Philadelphia.

**DIAMONDS.**

**C. COTTIER & SON,** IMPORTERS OF  
14 MAIDEN LANE, NEW YORK. PRECIOUS STONES.

C. A. RICHARDS, Agt. 151 Weybosset St., Prov., R. I.

**FANCY GEMS.**

**HAGAN, WHITE & CO.,**

MANUFACTURERS OF

**GOLD AND SILVER MOUNTED CANES, UMBRELLAS & NOVELTIES.**

RICH AMERICAN CUT GLASS, SILVER MOUNTED.

248 WEST 23D STREET.

NEW YORK.

**Diamond Polishing Machines.**

We build these machines complete with latest improvements also polishing wheels, tongs, dousps, weights, shafting, belting, ventilating fans, gear-cutting, die blanks, etc., We do general repair work on jeweler's machinery.

**THE ARTHUR CO.,**

General Machine Works,

86 JOHN STREET, NEW YORK.

**U. S. SMELTING & REFINING WORKS.**

Sweep Smelting and Assaying. Platinum in Plate and Wire. Chemically Pure Copper. Ore and Bullion Assays a specialty.

Highest prices paid for old gold and silver. Sole manufacturers of Phoenix Flux and Eureka Alloy.

M. WOLLSTEIN, 25 John St., New York.

**S. F. MYERS & CO.,**

Manufacturing and

WHOLESALE JEWELERS,

1895 Issue, No. 39.

**OUR ROYAL CATALOGUE**

Illustrates all that is new, unique and desirable in

everything that pertains to jewelry. 600 pages, size of this publication. Free to dealers.

SEVEN DOUBLE FLOORS.  
TWENTY-TWO DEPARTMENTS.

Myers Buildings, 48-50 Maiden Lane, New York.  
33-35 Liberty St.,



.. OUR ..  
**SPECIALTY**

The Largest Stock of

CHIMING

> AND <

STRIKING

**HALL CLOCKS**

ever shown.

**Chas. Jacques**

CLOCK CO.,

22 Cortlandt Street,  
NEW YORK.

**B. & W. B. SMITH,**

220 W. 29th St., New York.

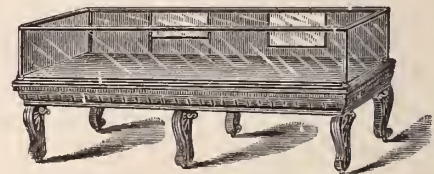

Improved Dust-Tight Counter Cases,  
Perpendicular Sliding Doors.

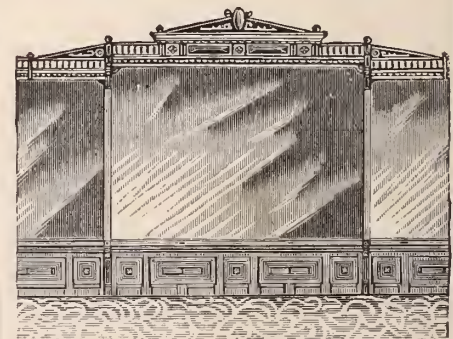

Improved Dust-Tight Wall Cases.  
Furnished with Improved Shelving and arranged for Electric Lighting.

**IT PAYS** TO KEEP IN TOUCH WITH TRADE AFFAIRS. For 4c. a Week will do it. **Subscribe.**  
THE JEWELERS' CIRCULAR.

DIAMONDS and Cutters. L. & M. KAHN & CO., 172 Broadway, NEW YORK, DIAMONDS

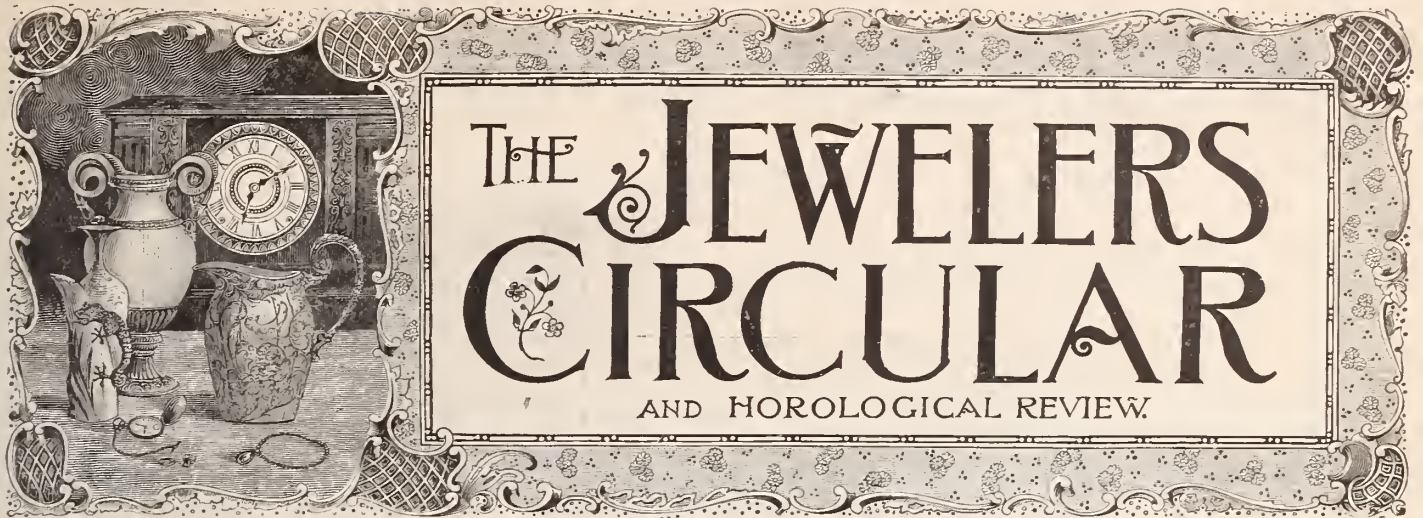

# THE JEWELERS CIRCULAR

AND HOROLOGICAL REVIEW

Copyright by THE JEWELERS' CIRCULAR PUB. CO.

189 Broadway, New York.

Entered at the Post Office in N. Y. as second-class matter.

VOL. XXIX.

NEW YORK, WEDNESDAY, DEC. 12, 1894.

NO. 20.

## SILVER WREATHS FOR THE CZAR'S FUNERAL.

FRANCE remembered the late Czar of Russia in many graceful manners, among which the sending of mourning wreaths of silver was not the least notable.

crossing (*entre-croisement*) the branches are curled in a way to form a small garland tied with a knot of ribbons showing Russian and French colors intertwined; the ends of the knot fall irregularly in the space confined by the garland. The ensemble is applied on an Imperial mantle in pansy colored velvet with silver fringes, draped with cords from which depend silver tassels. Two French flags overhung with crape rise behind the mantle.

Let us also mention a black marble escutcheon, two meters 50 centimeters high, and one meter, 80 centimeters wide, on which are applied two large palm branches in green gold, tied by a ribbon, with two branches of laurel and olive tree in silver. In the center are placed the arms of the Russian Emperor. They are in silver, finely chased. This was the work of Christofle & Co., and was offered by the French Minister of Foreign Affairs.

The wreath subscribed by the stock-brokers' syndicate is also worthy of notice. It is in silver, slightly oxidized, and applied



SOUVENIR SENT BY THE RUSSIAN COLONY IN PARIS.

A magnificent wreath in chased silver, two meters high and one meter 50 centimeters wide was sent by President Casimir-Perier to the Russian Government as a memorial to the death of the Czar. It consists of two branches of oak tree in oxidized silver crossing each other and held together with ribbons in the same metal bearing the inscription: *A sa Majesté l'Empereur Alexandre III, le Président de la République Française.* A branch of olive tree in faded *vieillot* is thrown across the wreath. The leaves and fruits on the branches are in repoussé and finished in the old iron work style. At the upper

The wreath inscribed by the Paris Press may be considered as the most artistic. In the space confined by this silver wreath, formed of laurel and oak branches, the slender figure of a modern Fame, veiled and clad with a long robe, and with large wings displayed, appears to soar. Holding with her left hand a blank book, and with the other lifted up, a pen she appears to be in deep thought, previous to writing the memorable life of the late Czar. This figure was modeled by the well known sculptor Falguière. It has sprung to life under a stroke of genius. This Fame, 75 centimeters high, has her right foot resting on a hemisphere bearing on a scroll the following inscription: *A la Mémoire d'Alexandre III. la Presse Française.* Her left foot stretched behind seems to accelerate her motion. The artist never made a work more impressive and more refined. Ducoc, of the Rue de la Paix, was entrusted with the casting and the finishing of this remarkable statue in oxidized silver. The wings were cast separately and soldered to the figure. The whole work was executed in a few hours. With the stand, in ebony, 15 centimeters high, the ensemble measures one meter 25 centimeters in height.



WREATH SENT BY PRESIDENT CASIMIR-PERIER.

on a black velvet ground. A silver figure of grief in bas-relief modeled by H. Peyrol is placing at the top of the wreath a veil which is meant to hang over the arms of Russia.

The French Navy sent Chapin's bas-relief in bronze, "la Pensée," surmounted with an

# ★ ROGERS & BRO., A I.

## ORANGE SEASON....

### ORANGE KNIVES.



Pearl, Ivoride or Plated Handles,  
Cutting Edge, Saw Back Blades.  
*(A feature first introduced by us),* making  
a good all round Fruit Knife.

### ORANGE SPOONS.

- FLEMISH
- COLUMBIA
- SAVOY
- TUXEDO
- HARVARD
- YALE
- PRINCETON
- STOCKBRIDGE
- FLORIDA
- SHELL

PATTERNS.

Put up in sets of 6 in Plush Lined Boxes.

### ORANGE SETS.

1 Knife and 1 Spoon, or  
6 Knives and 6 Spoons.  
Put up in Plush Lined Boxes.

### ORANGE PEELERS.

..... POCKET OR TABLE SIZES.

### ORANGE HOLDERS.

Also a Large Line of Fancy Pieces put up in Beautiful  
Plush Lined Boxes. Suitable for the Holiday Trade.

FLEMISH ORANGE SET, No. 5.

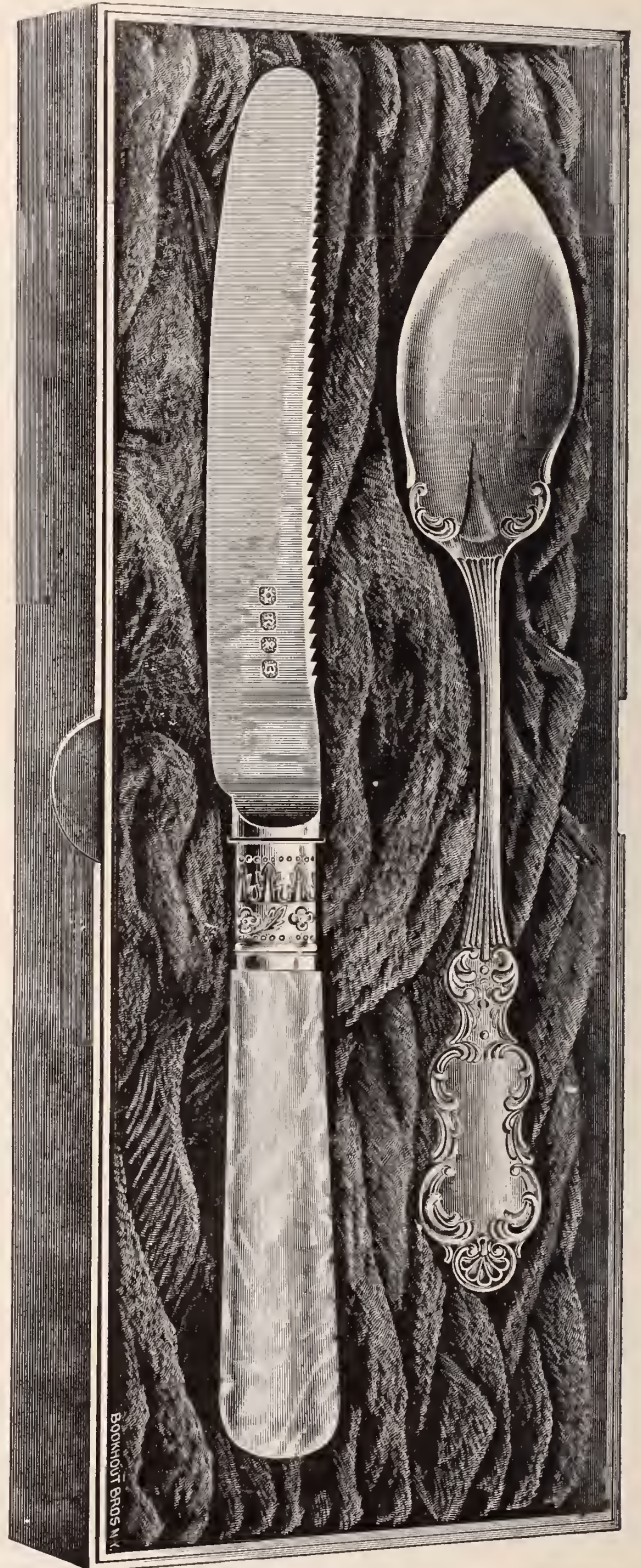

# ROGERS & BROTHER,

16 Cortlandt St., New York  
WATERBURY, CONN.

THE OLDEST MANUFACTURERS OF ROGERS' GOODS IN EXISTENCE.



# Foster & Bailey,

MANUFACTURING JEWELERS AND SILVERSMITHS,

100 Richmond St., Providence, R. I.



**S**TERLING SILVER  
MANICURE SETS,

925-1000 Fine,

With Shoe Horn and  
Shoe Buttoner.

MADE OF THE BEST STEEL PARTS.

Put up in Fine Leather Roll,  
Lined with Dark Green Velvet  
and Having Beautiful Silk Flaps  
to fold over.

When Rolled Up it is Soft-  
Pliable, and Just the Thing to  
Pack in a Grip.

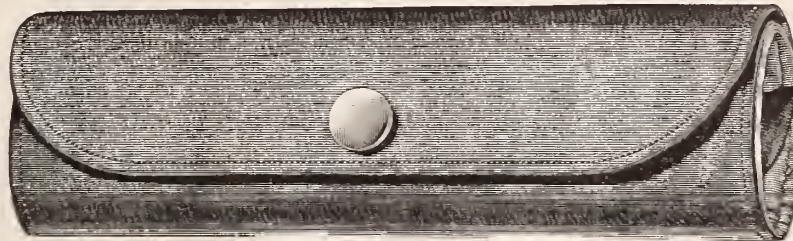

SET ROLLED UP—REDUCED ONE HALF EACH WAY.

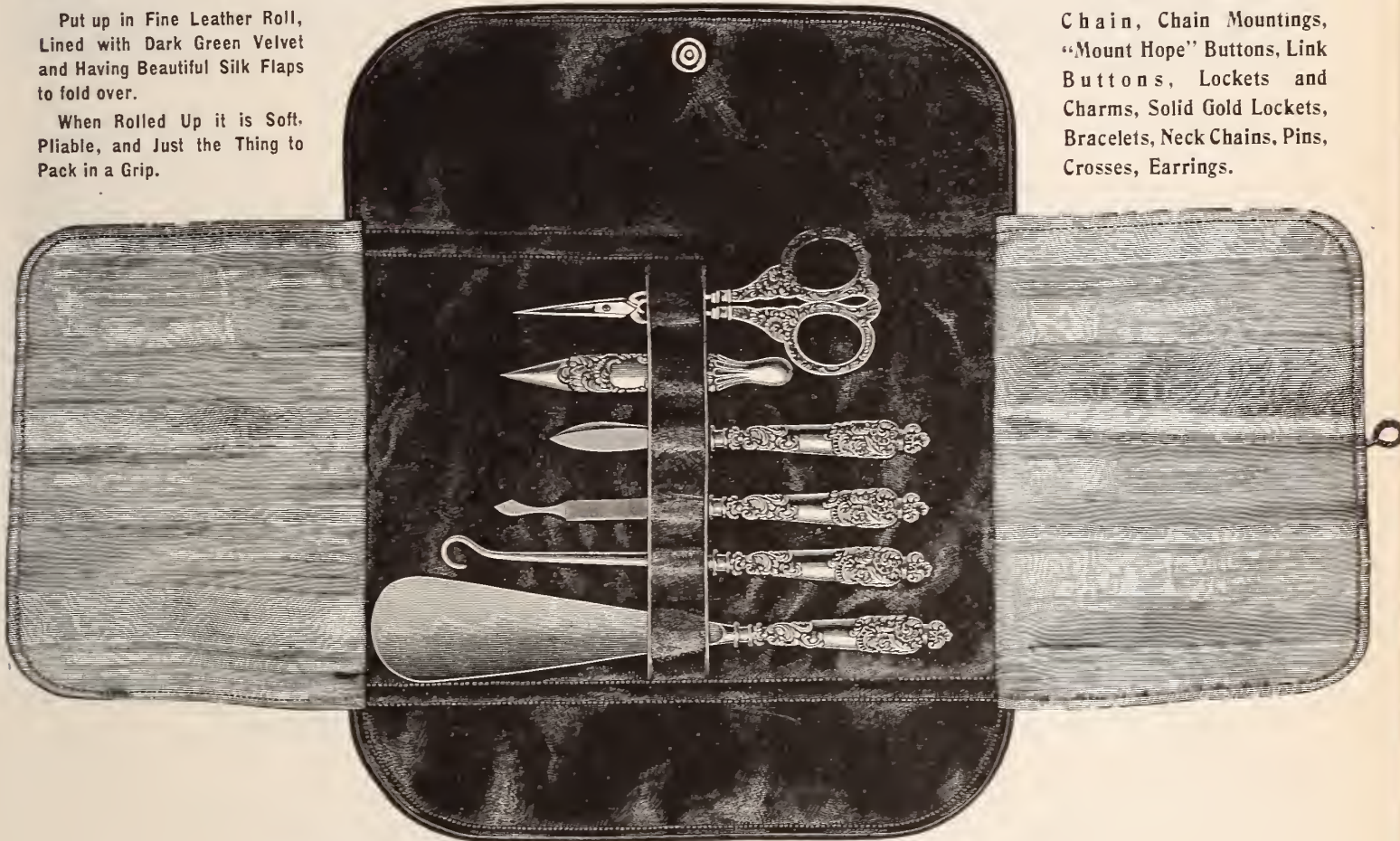

NO. 7 SET—REDUCED ONE HALF EACH WAY.

No. 138 File and Cuticle Knife Combined.  
" 139 Corn Knife.

No. 140 Button Hook.  
" 141 Shoe Horn.

No. 142 Nail Cleaner and Ear Spoon.  
" 143 Curved Scissors.

MANICURE SETS IN FINE KID CASES.

## STERLING SILVER SET No. 1, CONTAINS:

No. 54 - Tray.  
" 55 - Polisher Box.  
56 - Polisher.

No. 57 - - Paste Box.  
" 57 - - Powder Box.  
" 58 - - File.

No. 59 - Corn Knife.  
" 60 - Cuticle Knife.  
" 61 - Short Scissors

No. 70 - Long Scissors.  
Box.

. 2 and No. 3 also in Sterling Silver, with less pieces, therefore cheaper in price. Nos. 4, 5 and 6 are in 1-10 Gold.  
All parts can be ordered separately, and all steel is of the best.

anchor from which hang draperies with the national colors overhung with crape.

The French mission sent by the Government to attend the Czar's funeral offered an



WREATH SENT BY THE PARIS STOCKBROKERS.

escutcheon on black velvet on which are applied the following words in Russian letters: "To Alexander III., the extraordinary French mission." Branches in gilt radiate all round the escutcheon. At the

top there is a rippling bow knot in gilt coming out on crape.

The souvenir offered by General de Boisdreffre, chief of the mission, consisted of a black velvet shield on which come out branches of olive and oak tree in silver, half framing an appropriate inscription in Russian. The silver wreath subscribed by the Paris press weighs with the statuette 38 kilogrammes.

Among the numerous souvenirs sent from France to Russia on the occasion of Alexander III.'s funeral, the one offered by General Mercier, Minister of War, in the name of the French army, deserves special mention. It consists of a black velvet escutcheon on which is applied a wreath formed of a branch of laurel and one of oak tree with sprigs of olive tree entwined around them. Between these branches, at the base, is placed a silver shield on which is chased the legendary scene, Saint George and the dragon. A scroll displayed above the shield bears the following inscription: "A l'Empereur Alexandre III. l'Armée Française." This work, in cast silver, finely chased, was made at Thiebaut's. It is 2 meters, 10 centimeters high, and 1 meter 50 centimeters wide. Two French flags, partly covered with crape raise behind the velvet escutcheon.

The Russian colony in Paris sent to Saint Petersburg a remarkable work of art. It is a bas-relief designed by the painter, Makowski, and executed by the sculptor, Bern-

stamm. It shows a Russian woman in a handsome costume, seated in an attitude bespeaking deep sorrow. One of her hands shelters her weeping eyes; the other, rest-



WREATH SENT BY THE PARIS PRESS.

ing on the emblematic shield of the town of Paris, holds a torch dying out. The profile of the Kremlin lighted up by the setting sun faintly appears amid the smoke which spreads above the torch. A large palm branch borders the scene on the right hand side, bends when reaching the top, and then droops over the Russian imperial eagle. At the base on the left there are a branch of oak tree and a sprig of olive tree tied by a ribbon with the lower part of the palm branch. This artistic piece, in bronze, is 2 meters and a half high. It is placed upon a large drapery in black velvet constellated with hermie, which is caught at the top with a large silver wreath tied on it with cords from which hang on both sides big tassels also in silver.

## A. J. HEDGES & CO.,

MANUFACTURERS OF

Gold, Variegated and Enameled Jewelry.

BLACK AND WHITE ENAMELED GOODS

— A SPECIALTY. —

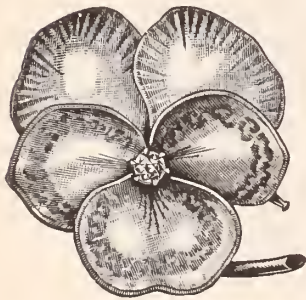

FACTORY:  
90 Mechanic St., Newark, N. J.

SIDE COMBS AND COLLARETTES, LACE PINS, SCARF PINS, BROOCHES AND PENDANTS, CHATELAINES AND BRACELETS, LINK BUTTONS AND STUDS, LADIES' AND GENTLEMEN'S GOLD AND SILVER GARTERS.

6 Maiden Lane, New York.

## L. SAUTER & CO.,

Dealers in Diamonds

... AND ...

Makers of Fine Jewelry,

194 BROADWAY, NEW YORK.



Selection Packages sent on request. Mounting of Diamonds and other precious stones in new and original designs a specialty.

## FERD. FUCHS & BROS. SILVERSMITHS,

MAKERS OF STERLING SILVERWARE,  
808-810 Greenwich St., New York.

For **BADGES and MEDALS,**  
Flag Pins, Class Pins, Class Rings  
and Special Work of all Descriptions,  
SEND TO **E. R. STOCKWELL, MANUF'R,**  
19 John Street, New York.

JACOT & SON  
IMPORTERS AND  
MANUFACTURERS  
OF  
MUSICAL BOXES  
39  
Union Sq.  
New York.



*Pairpoint*

# MANUFACTURING COMPANY.

## Gold and Silver Plate



No. 3749. MATCH HOLDER.

WE ARE MAKERS OF THE  
LARGEST AND LOWEST PRICED

...LINE OF.....

“Crown Pairpoint” China

Rich Cut Glass,

Fine Decorated Art Goods,

.....TO BE FOUND IN THIS COUNTRY.



No. 4908. SMOKING SET.

“WHEN IN DOUBT”

--- BUY ---

✻ PAIRPOINT GOODS.

Factories, New Bedford, Mass.

### HOLIDAY NOVELTIES

..... OF EVERY DESCRIPTION.

**FREE**

OUR LATEST

SILVERWARE CATALOGUE No. 10, or  
CUT GLASS CATALOGUE No. 11

Will be mailed you upon receipt of address



SALESROOMS :

NEW YORK, 46 Murray Street.

CHICAGO, 224 Wabash Avenue.

SAN FRANCISCO, 220 Sutter Street.

MONTREAL, P. Q., Temple Building.



No. 2832. KNIFE SHARPENER.

We sell to the legitimate Jewelry and Stationery trade only.



## CHOICE PAPERS

MAKERS OF

# FINE STATIONERY

For Correspondence, Wedding and Business Use, handsomely boxed, specially suited to the Jewelry Trade.

18 MURRAY STREET, NEW YORK.

## LATEST STYLES

... IN ...

# FINE JEWELRY.

GOLD BUCKLES,  
HAIR PINS,  
BACK COMBS,  
SIDE COMBS,  
NECK ORNAMENTS, Etc.

John A. Riley & Sloan Co.,  
Broadway and 17th Street,  
NEW YORK.

### 2 MEDALS AWARDED



Wm. K. POTTER,  
TURTLE SHELL WORKS, PROVIDENCE, R.I.

TRADE MARK.

AT  
WORLD'S  
FAIR,  
1893.

Providence Shell Works, Providence, R. I.  
Correspondence Invited.

# R. WALLACE & SONS MFG. CO.

## SILVERSMITHS,

WALLINGFORD, - - - - - CONN.



No. 20. FLASK.

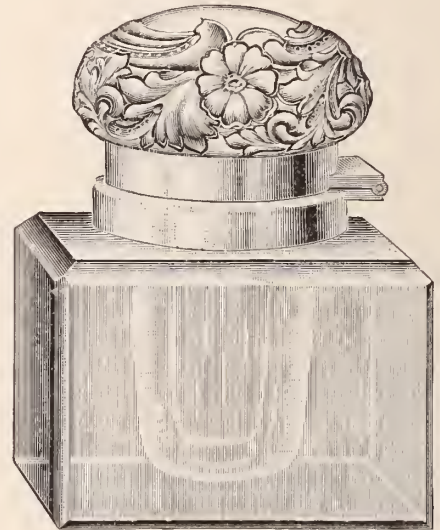

No. 53. INK BOTTLE.  
CHASED TOP.

Trade Mark.

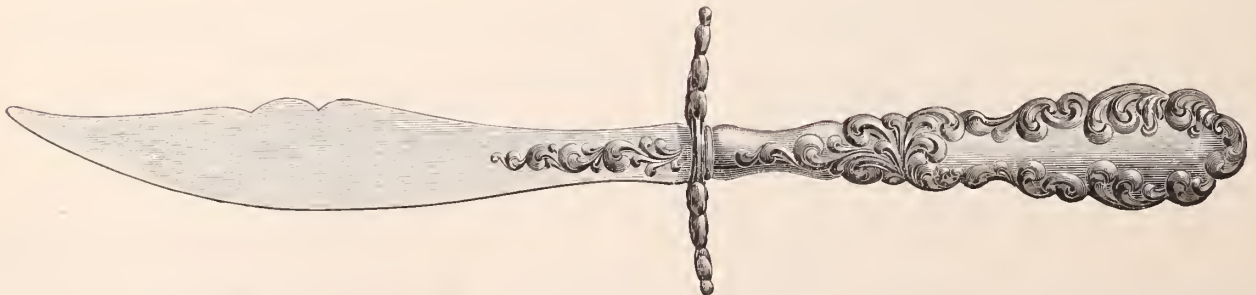

No. 39. PAPER CUTTER.

NEW YORK  
226 FIFTH AVENUE.

SAN FRANCISCO  
120 SUTTER STREET.

CHICAGO  
86 WABASH AVENUE.

### A Salesman Chases a Thief From Providence to the Orient.

PROVIDENCE, R. I., Dec. 5.—About the middle of September a well known Armenian of this city, George Moore, suddenly disappeared, without intimating to any one his reason for so doing. Simultaneous with his leaving town a quantity of sample jewelry valued at about \$500, the property of Wallace & Simmons, jobbers of this city, also disappeared. Mr. Moore, it appears, was salesman for this firm. His field was the Armenian colony and he did quite a flourishing business.

Nothing was heard of the absentee for nearly two months and the Armenians here had almost forgotten that such a person as George Moore ever existed. Several days ago the young man appeared in the city as suddenly as he had quitted it. Since last seen hereabouts Moore has been on a long journey whose object was to find the man who had robbed him, for the young man had been relieved of the \$500 worth of Wallace & Simmons' jewelry.

Moore lived in an Armenian boarding house where he became acquainted with a fellow-countryman named Hagopian. One day while Moore was away from the house Hagopian entered his sleeping apartments, captured the entire lot of valuables and ran away. Moore, without giving himself barely time to ponder over his misfortune, decided to start in pursuit of Hagopian. He wrote a letter to his employes, in which he informed them what had occurred, and also his intention to find Hagopian and secure the property. This note, owing to some mishap, never reached Wallace & Simmons, and consequently the evil stories circulated during the young man's two months' absence were never repudiated.

Learning that Hagopian had gone to Boston, Moore went there to find him. Meeting friends there and learning that Hagopian had gone to New York, he proceeded to the metropolis, where he arrived just in time to learn that Hagopian had taken the steamer for London. The following day Moore left by another steamer for England. Upon his arrival in London he visited an Armenian coffee house, where he learned that his man had taken ship for Alexandria. He then engaged passage on the next steamer, which sailed a few hours after Hagopian's departure. His boat remained two days at Naples and so was two days late in reaching Alexandria. Hagopian had already arrived there and had departed for Cairo, whither Moore followed him with ultimate success.

Knowing that Hagopian could speak but little English and in order to make himself understood that he must go where his countrymen were, the most natural place to find him was in the Armenian coffee house and so Moore went there immediately upon landing. There he found him. When Moore entered Hagopian just concluded bargaining with the landlord for lodgings. He turned round suddenly and saw his pursuer and was considerably surprised.

Moore grabbed him and demanded the jewelry which was handed over without any trouble, that is, what there was remaining.

Moore says that he would have had the man arrested and brought back to this country, but the American Consul at Cairo told him such a course without extradition papers could not be pursued. Hagopian was afraid of arrest and promised to pay Moore's traveling expenses if he would drop the idea of criminal prosecution. As the dishonest Armenian had no ready money he gave his note for \$175, what it cost Moore to recover the jewelry, and agreed to take it up in six months. After transacting his business in Cairo Moore left for home, and arrived here a few days ago. The first duty Moore performed was to return Wallace & Simmons' property, with the exception of two pieces pawned in London. Mr. Wallace speaks very highly of the young man and says he has no doubts as to his honesty. Moore has been reinstated as the firm's agent.

### Ham's Silver Plating Machine Scheme Lands Him in Jail.

EAST ST. LOUIS, Ill., Nov. 30.—S. H. Ham, who has been doing business in East St. Louis for several years under the name of the Queen City Silver and Nickel Plating Co., and who is alleged to have swindled hundreds of persons in all parts of the country out of sums ranging from \$5 to \$25, was arraigned before United States Commissioner F. B. Bowman last week for examination on the charge of using the mails for fraudulent purposes, preferred by postmaster W. G. D. Mercer, of Chicago.

The police arrested Ham on last Monday night on the strength of a telegram from Chicago, stating that he was wanted by the United States authorities. Inspector Mercer, Deputy United States Marshal G. W. Eberhart and Assistant Prosecuting Attorney Brainerd arrived in the forenoon to prosecute the case. Ham has been taking orders for plating machines, which he sold for \$5 each, giving purchasers certain territory and assuring them that they could earn from \$10 to \$50 a day by plating household and other ware. The East St. Louis police received many complaints from persons who claimed to have forwarded money for machines or material and to have received nothing in return.

Ham was arrested and held on the charge of fraud about a year ago, but the grand jury failed to indict him. Inspector Mercer expects to make a case against him on the testimony of E. J. DeLain, Ottawa, Ont. DeLain claims that he forwarded \$5 to Ham for a plating machine and \$18.55 for materials, which, according to his allegations, were never delivered.

Mr. Cuker had sold his jewelry establishment in Roseland, Ill., to L. A. Broadhaus & Son, of Plano, and has departed for his old home in Maine.

# Diamonds

... AND ...

# Diamond Jewelry

... FOR THE ...

## HOLIDAYS.

We have an unusually large stock of mounted goods all set in the latest designs of mountings and at prices that cannot be beaten.

We have imported a large reserve stock of Diamonds, and will not advance any of our prices at present. Dealers making their selections now will have the full advantage of the low tariff prevailing on Diamonds before the Wilson Bill went into effect.

You can save 15 per cent. by buying your Holiday Stock now.

If inconvenient to call upon us, or if you have a call for some special article not in your stock, let us send you a selection package.

## Cross & Beguelin

Loose—DIAMONDS—Mounted.

17 Maiden Lane,  
New York.

43 RUE MESLAY, PARIS.

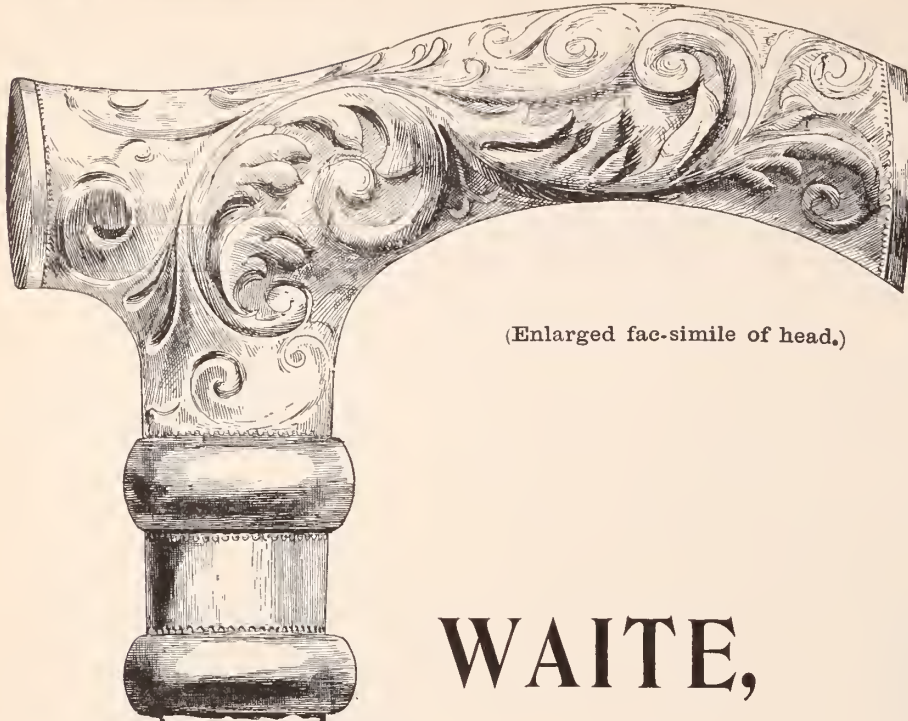

(Enlarged fac-simile of head.)

OUR  
**CANE**  
 Stick  
 And  
**Lapel**  
 Pins.

PATENTED  
 OCT. 23, 1894  
 ARE  
 THE  
 PROPER  
 THING.

HEADS  
 ARE OF  
 SOLID  
 GOLD OR  
 STERLING  
 SILVER,

Artistically  
 CHASED.  
 STICKS  
 ARE  
 ENAMELED  
 TO  
 REPRESENT  
 NATURAL  
 WOODS.

THEY SELL AT  
 SIGHT.

**WAITE,**  
**THRESHER**  
**COMPANY,**  
**Providence, R. I.**

ESTABLISHED 1870.



TRADE MARK.

**SAMUEL C. JACKSON,**

MANUFACTURER OF

**FINE CASES FOR**

Jewelry, Silverware, &c., also Hardwood  
 Chests, Trays, and Sample Cases.

**180 BROADWAY,**

**NEW YORK.**



SPECIALTY: SALES OF  
**JEWELRY BRIC-À-BRAC**  
 AND  
 ARTICLES OF VERTU

**SAFES FOR JEWELERS.**  
**MOSLER, BAHMANN & CO.,** 518 BROADWAY  
 NEW YORK.  
 Patent Fire and Burglar Proof Safes.



Large Assortment Always on Hand.  
 Send for our Representative.  
 Special Safes to Order.  
 Jewelers' Safes a Specialty.

### Meeting of Massachusetts Retailers Not Wholly Harmonious.

BOSTON, Mass., Dec. 4.—Upward of 50 retailers from all parts of the State met this afternoon at the Boston Chamber of Commerce to consider the matter of forming an organization, Newton Dexter, of New York, who has been active in the preliminary work of preparing for such a movement, being present to explain the plans adopted in other States under his direction.

The call for the meeting was in a measure a summary of the principal abuses which the retailers have to contend with, such as competition with dealers who handle falsely stamped silver or gold wares, inferior goods in the guise of standard articles, shyster auction sales, false advertising, and other familiar forms of fraud. Organization was suggested as the only weapon with which to combat the evils referred to, "the only way to get laws regulating the stamp on gold and silver manufactures, the only way to compel the manufacturers to protect their customers, the only way to make the jobbers respect the rights of the retailers." It was signed by the following dealers, many of whom were represented in the gathering:

N. G. Wood & Sons, Alvah Skinner & Son, C. J. F. Sherman & Son, Freeman & Taylor, S. G. Brooks, H. S. Townsend, C. W. Wingate, Harrington & Freeman, Stanton & Glover, G. W. Ray, F. L. Webb, F. F. Place, G. E. Homer, S. G. Smith, B. McDevitt, W. C. Potter, E. H. Miller & Co., A. J. Macomber, of Boston; H. G. Hudson, Amesbury; Chas. W. Morse, Brookline; A. J. Applegate, Cambridge; John W. Babbitt, Danvers; George F. Horton & Co., East Somerville; E. J. Corcoran, Abel Burrows, I. T. Boyd, Fall River; W. H. Goss, Haverhill; Thos. Margetts, Hingham; H. E. French, Hudson; Jas. M. Moore, W. F. Newhall, J. H. Connor, A. J. Pearson, C. S. Hart, Lynn; James T. Murray, S. X. Paige, Henry Lavalle, Frank Ricard, Alfred Simard, Harry Raynes, Charles H. Packard, John D. Grant, G. W. Dudley, Lowell; H. P. N. Dahl, Maynard; C. W.

Ambrose, Natick; J. A. Derter, I. J. Frigault, George Kelley, New Bedford; Alfred P. Harriott, Norwood; W. P. Jones, Newburyport; C. F. Pettingill, Quincy; W. N. Manning, Rockport; George A. Collins & Co., Daniel Low, Salem; A. W. Harris, South Deerfield; Cyrus N. Gibbs, South Framingham; M. Madsen, South Hadley; E. D. Tisdale & Son, F. M. Nichols, Taunton; Edward H. Frary, G. Thompson, Weymouth; Fred S. Scales, Winchester; and many others, so the circular stated, that were received too late to be printed.

A. N. Wood, of Boston, presided, and W. F. Newhall, of Lynn, was secretary. Mr. Dexter spoke for about an hour on the value of organization and the plan he has presented to other similar bodies. He laid particular stress on the manufacturer and jobber who do not protect the retailer, and denounced tricky manufacturers especially in unmeasured terms.

A discussion followed on a motion made by Mr. Morse, of Brookline, that the meeting proceed to effect a permanent organization. This motion was opposed by Mr. Byrne, of the firm of Wilson Bros., Boston, who opposed hasty action. John Wilson, of the same firm, was in favor of a well considered movement to reform abuses which were acknowledged to exist, but said he did not wish to see the jewelers rush into an organization of which nothing as yet was evident except that the chief promoter desired to see himself elected as counsel for the members at a handsome salary. The sentiment of the meeting was overwhelmingly in favor of taking action without delay, however, when the question was put to a vote, and the chairman was authorized to appoint a committee of five to prepare a list of officers to be presented at a meeting which will be held at the same place Jan. 15.

After the meeting John Wilson, of Wilson Bros., stated his side of the subject more in detail to a reporter, as follows:

"We attended the meeting and listened very carefully to Mr. Dexter, whose experience in organizing other trades seemed to be his passport and introduction to the

jewelers of Massachusetts. We all know that abuses exist to-day, and have always existed among dishonest dealers to a degree far more harmful than the course of some manufacturers in their failure to protect the trade.

"Whether or not wilful and deliberate wrongdoers could be compelled to do right by legislation is and always has been, an open question, and a large number of the jewelers present at the meeting to-day are opposed to hasty action which might antagonize the manufacturers without benefitting themselves. The fact that there is already a National organization which aims to correct acknowledged abuses seemed to us reasonable cause for counseling an adjournment before committing ourselves to any specific plan of action without further light and without more definite knowledge as to what has already been accomplished in other States.

"The reputable jewelers of Boston while ready to co-operate with their brother jewelers throughout the State in protecting themselves against misleading advertisers who publish fictitious bargains, and whose solid gold so often turns out to be as worthless as brass, are not prepared to create an organization and support officers and counsel and enter upon a campaign of so-called protection. Our individual opinion is that the honest jeweler who has strictly one price, and who sells goods for exactly what they are, charging only fair profit, will always be generously patronized; and so long as he refuses to enter into any entangling alliances with any manufacturers, but steers his bark clear of such rocks, right through the open sea of fair competition, he will have no need of organized protection. The man who clamors loudest for protection is apt to be the man who fears honest competition.

"As an evidence that our views were favorably received by a large number of those present all details of organization were deferred until an adjourned meeting to be held in this city Jan. 15. At that time the holiday rush will be over, and we shall be at leisure to look carefully into this matter."

## DON'T LET A GOOD THING ESCAPE YOU.



18 SIZE, 7 JEWELS.

THE REDUCED PRICE ON ALL GRADES OF TRENTON MOVEMENTS PLACES THEM WITHIN REACH OF EVERYBODY AND SURPASSES ALL COMPETITION. THEIR EVER INCREASING POPULARITY IS DUE TO THE UNIVERSAL SATISFACTION THEY ARE GIVING. THOUGH LOW IN PRICE, THEY ARE HIGH IN QUALITY.

SEND FOR ILLUSTRATED PRICE LIST,  
AND ORDER FROM YOUR JOBBER.



16 SIZE, 16 JEWELS.

# TRENTON WATCH CO.,

TRENTON, N. J.

# A MODEL FACTORY BUILDING.

THE KENT & STANLEY CO.'S MAMMOTH NEW STRUCTURE, THE FINEST OF ITS KIND IN THE WORLD.

**P**ROMINENT among the many handsome factory buildings for which Providence is noted is the handsome structure built and occupied by the Kent & Stanley Co., on the Square bounded by Sabin, Aborn, Beverly and Mason Sts., in that

city. The property which it occupies was the location of the old-time popular skating rink, destroyed by fire last year. Mr. Edwin F. Kent, recognizing the advantages of the site, on his own responsibility purchased the property after the fire, though at that time the building occupied by the Kent & Stanley Co., at Eddy and Fountain Sts., was generally looked upon as a model factory, excellently planned and perfectly equipped.

Mr. Kent's foresight in the matter of the purchase of the new site was soon endorsed by his partners. Its proximity to the new railroad depot, which will be one of, if indeed not the finest, in the country is a guarantee of increasing values in that section of the city, while the increased shop room was something rendered imperative by the firm's constantly increasing business.

Work on the new structure which is depicted in one of the illustrations in this article, was begun on November 1, 1893, and October 1, 1894, the company was operating in its new quarters.

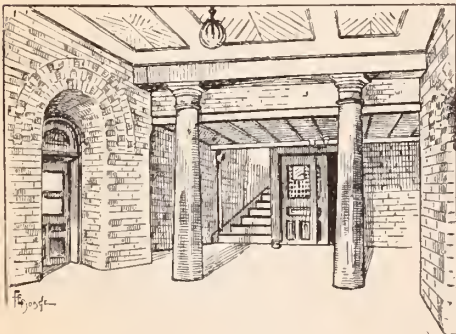

MAIN ENTRANCE ON SABIN ST.

The readers of the CIRCULAR can gather an idea of the immensity of the structure when it is borne in mind that it occupies an

acre of ground, rises seven stories above the foundation, has over 250,000 square feet of floor space, about 1,200 windows and required over five million bricks in its construction. While nearly all available space has already been leased, firms seeking modern quarters will do well to bear in mind that rentals are figured on a basis of 30 cents per square foot per annum, including power, steam heat water and elevator service.

The ground plan and character of the plot is excellently suited for the purpose to which it has been put. The L shaped formation gives it a frontage of 276 feet on Mason St., 221 feet on Aborn St., 106 feet on Sabin St., and 123 feet on Beverly St. A light well 40x200 feet extends from roof to basement in the main structure



THE KENT & STANLEY CO.'S BUILDING.

which with the additional advantage of four street frontages makes that great desideratum, good light, an assured fact for each tenant.

Red brick with brownstone trimmings was the material used for the walls, which rest on particularly solid foundations. At either corner on the Sabin St. facade are two handsome flag staffs held in place by artistic creations in wrought iron of dragons, one of which is incorporated in the initial letter beginning this article. Flags floating from these staffs bear, one, the company's trade mark on a white field and the other the national colors.

The two entrances to the building are well worthy of attention. Each shows a granite arch, while within enameled bricks of a light bluff tint please the eye and present an imperishable surface.

## THE KENT & STANLEY CO.

Our illustration shows the Sabin St. entrance with the handsome wrought iron elevator in the back ground, and two beautifully silvered supporting columns. The other entrance on Beverly St. is practically the same. Marble slabs for the names of the tenants is another feature not usually found in a factory building, and rapid running passenger elevators at either entrance afford quick access to, or egress from any floor. In the driveway running through from Sabin to Mason Sts., are two commodious freight elevators.

Floorings throughout are of maple, each floor being nearly an acre in area. The supporting columns are of iron, rising thirteen feet to the ceilings. Grinnell sprinklers and all other modern factory conveniences make the building a perfect one, whether from the view of the tenant, the insurance or the factory inspectors. Over 3 500 hands can find accommodation within its walls. Power and light are furnished by the company's private electric plant, one of the finest in the country.

The offices of the Kent & Stanley Co. are fitted up in oak, in the best taste, and pre-

sent an exceedingly attractive and handsome appearance. They occupy practically the whole of the Sabin St. wing on the sixth floor. Our illustration shows a view of the general office; adjoining it is the private office of Mr. E. F. Kent, which also connects with the director's suite.

The Kent & Stanley Co.'s shop, ever known as a model one, is in the new building better than ever. In one of the illustrations accompanying this article is shown a corner in the silver shop, a line in which the company is winning rapid recognition, and of which some of the productions, notably yachting trophies, have already been the subject of extended mention in the CIRCULAR.

A pioneer in selling its goods directly to the retail trade, the company, through its ten traveling salesmen and New York, Boston, Philadelphia and San Francisco offices offers a wide and varied line of goods. Some idea of its scope can be gathered from the fact that among them are:

## THE KENT &amp; STANLEY CO.

One-tenth and one-quarter Gold Seamless Wire Chains; Gents' Rolled Plate Vests, all Seamless Wire, 1, 2, 3, Strand Curbs; Dickens, Trace, Rope, Single Curb, Boston



VIEW OF GENERAL OFFICE.

and Fancy Links; Red Gold and Platinum Links in all styles; Ladies' Lorgnette, Neck, Vest and Victoria Chains; 1,500 styles Gold, Silver and Plated Locketts and charms; White Stone Lace Pins and Brooches; Hair Ornaments; Chain Bracelets, Plate and Sterling Silver; Hat, Hair, Stick, Scarf and Bib Pins; Plated Sword Corsage Pins; Bracelet and Eye-Glass Chains.

In Sterling Silver Novelties, all warranted Sterling Silver are: Garters, Collarettes, Pocket Combs. Tie Holders; Belts with Silver, Pearl and Tortoise Shell Buckles, Paper Cutters and Weights, Match and Stamp Boxes, Trays, Letter Clips, Letter Openers, Book Marks, Prayer Book Marks, Thermometers and Calendars, Satchel Tags, Hat Marks, Coat Hangers, Souvenir Spoons, Umbrella Clasps, Pearl Teething Rings and Rattles, Glove Hooks, Button Hooks, Glove Stretchers, and Hat Buckles, Hair Pins in Celluloid, Real Tortoise Shell, Silver Mounted; Tooth Brushes, Shoe Horns and Letter Seals, Mirrors, Game Counters, Cigarette Cases, Sword Corsage Pins, Key Ring Chains, Bonbon Spoons, Pocket Knives, Scissors, Razors, Manicure Articles, Gold and Silver Mounted Suspenders, Novelties in Leather Card Cases, Memorandum Books, etc.; Stag Handle Cutlery Novelties, Corkscrews and many others.

The company issued last year one of the finest illustrated catalogues ever put out by a jewelry house and another is now in preparation which will be even better than

## THE KENT &amp; STANLEY CO.

its predecessor, if that is possible. The business of the present Kent & Stanley Co. was first established in 1873 under the style of William H. Robinson & Co.,

## THE KENT &amp; STANLEY CO.

surviving partners, Edwin F. Kent and Arthur W. Stanley, under the old firm name. In 1887 these gentlemen purchased Mrs. Robinson's interest and continued under the style of Kent & Stanley. Under the new impetus, business during the two following years was doubled, but on Feb. 19, 1888, another fire once more interrupted operations by burning the factory entirely to the ground. Another shop was immediately found by Mr. Kent, and by noon of the day following the fire new machinery was already being put in position at the new shop, an instance of his indomitable will and prompt action in an emergency to which is due in a large measure the firm's success and high position to-day.

A lease of the ground on which the burned building had stood was quickly secured, and without the least unnecessary delay, Kent & Stanley began the erection of a building suitable to the needs of jewelry manufacturers which, when completed, ranked among the best factory buildings in the city. The firm took up its quarters in it and continued with increasing success. In February 1891, it was incorporated, under the title of the Kent & Stanley Co., being capitalized at \$300,000, represented in real property, and with charter rights for half a million. In November, 1893, the constantly increasing business necessitated larger quarters and the balance of the treasury stock was issued. In July, 1894, this additional stock had been issued, paid for in cash and invested in the new plant, which forms the subject of this article. It represents an investment of about \$350,000, and the total capital and surplus of the company in-

at 25 Calendar St. and the output consisted of chains. In 1882 Mr. Edwin F. Kent became a member of the firm and at once took an active interest in its welfare. In 1884 occurred the disastrous fire still remembered by the citizens of Providence, in

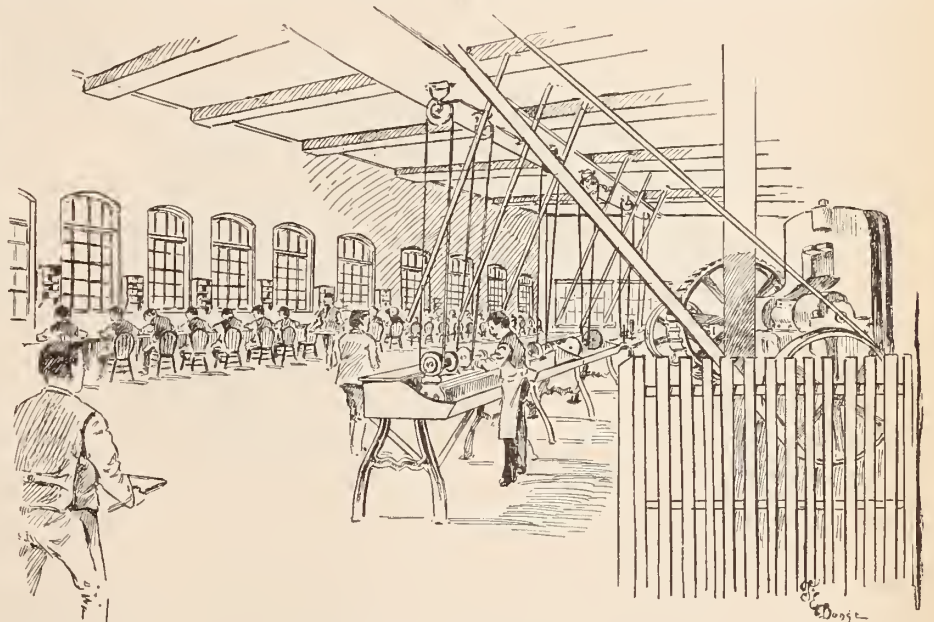

A CORNER IN THE SILVER SHOP.

which the factory was destroyed. New quarters were found at 7 Eddy St., and operations were again resumed. In 1885 Mr. Robinson died, and for nearly two years the business was conducted by the

vested in business is \$650,000. Its officers are: president, A. W. Stanley; treasurer, E. F. Kent; vice-president, J. S. Ingalls; secretary, J. D. Warren. George R. Clarke is superintendent and designer.

**DIAMONDS.**

**Wm. S. Hedges & Co.,**

**Importers of Diamonds,**

And Manufacturers of DIAMOND JEWELRY.

**170 Broadway, New York.**

22 Holborn Viaduct, London.

**Alfred H. Smith & Co.,**

IMPORTERS

DIAMONDS

AND

PRECIOUS STONES,

**82 BROADWAY, COR. JOHN STREET,**

**NEW YORK.**

**83 Holborn Viaduct, London. E. C.**

**R. A. KIPLING,**

**Precious Stones**

AND **Fancy Goods**

**Bought and Sold on Commission.**

**19 RUE DROUOT,**

**PARIS, FRANCE.**

**Watchman's Improved Time Detector**

**12 and 24 Different Keys with  
Safety Lock Attachments.**

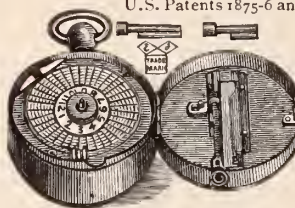

U.S. Patents 1875-6 and 7. Reissued, 1880.

This Watchman's Time Detector contains all latest improvements. The only perfect instrument in the market. It cannot be tampered with successfully. Warranted in every way.

Send for circular.

**E. IMHAUSER, 206 B'way, New York, U. S. A.**



**WM. SMITH & CO.,**

**Manufacturers of Gold, Silver and Roll Plate Chains and Jewelry.**



Novelties in Gold and Silver Bead Necklaces and Bracelets. Also a large line of Chain Trimmings and Silver Rings.

Office: 5 and 7 Maiden Lane, New York.      **Factory: 61 Peck Street, Providence, R. I.**

**The Death of Jacob Haller.**

DETROIT, Mich., Dec. 7.—Jacob Haller, one of the best known jewelers in the State and who resided in Ann Arbor, died at that place, last week. The cause of death was congestion of the lungs.

Mr. Haller was born in 1822, at Schwenningen Germany, and came to Ann Arbor, in 1854. In 1858 he opened a jewelry store on Huron St., and took his son George into the business with him. He retired a few years ago but continued in the business of making watchmakers' tools. In this industry he was probably the most skilled worker in the State and had a wide reputation among the trade.

In 1851 Mr. Haller received medals from the World's Exposition at London, for his superior grade of workmanship; also for the invention of certain watchmakers' tools. He also received medals from the Philadelphia Exposition authorities. He leaves four children.

**Failure of Charles S. Frantz.**

LANCASTER, Pa., Dec. 7.—Chas. S. Frantz, jeweler and optician, of this city, failed yesterday, the following executions being issued against him: Green Bros, \$200; Elizabeth Frantz, \$1,740; Spencer Optical Mfg. Co., \$857.67; Jacot & Son, and Wm. L. Gilbert Clock Co., \$105.18.

The heaviest judgment is held by Frantz's wife. It is impossible to estimate at present the value of his stock, although it is understood that recently he made some heavy purchases, and that there are many other creditors besides those who have secured judgment.

Frantz has been engaged in business here for a couple of years, and has not been rated as being financially very strong.

**Thieves After Blowing the Safe Escape on a Hand Car.**

ERIE, Pa., Dec. 5.—The town of Northeast was startled Monday morning by the report that the jewelry store of F. J. Lewis, had been looted by burglars. The burglars got away with between \$2,000 and \$3,000 worth of watches and jewelry. The burglary, it is thought, occurred some time after midnight Sunday, and an entrance was gained through a rear window of the store. The booty comprised a number of watches left with Mr. Lewis for repairing. The safe was blown open and its contents, even to the books, were taken by the robbers.

It is supposed that there were four men concerned in the robbery, and that, after looting the store, they repaired to the tracks of the Lake Shore Railway Company and utilized a hand-car to make good their escape from the town, coming in the direction of Erie. Several of the stolen articles were found outside the door of the store, on the sidewalk leading to the railway, and a chain and locket were discovered at the point where the robbers boarded the car. The four men believed to have



planned and executed the robbery were seen about town in the evening, but no definite description of their appearance is obtainable.

**Developments in the Affairs of Simon Rumpf.**

SEATTLE, Wash., Dec. 2.—Affidavits have been filed in several cases against the defaulting jeweler, Simon Rumpf. In one of them Arthur E. Griffin states that in conversation with Mayer, the latter stated that he had had a letter from Rumpf since he left Seattle, but declined to say from what point. Another affidavit was filed by R. W. Emmons, representing several creditors, who alleges that a quantity of the jewelry consigned to Rumpf was taken by Mayer to British Columbia, sold by auction and the profits divided with Rumpf.

Judge Langley has rescinded his order requiring the First National Bank to answer the order restraining its officers from delivering jewelry on deposit in its vaults as security. The dismissal of the restraining order is based on a stipulation signed by the receiver and the attorney of the bank, which sets forth that after inspection of the goods it was found that they were deposited by J. K. Bayse & Co., and form no part of the stock formerly owned by Simon Rumpf.

**It Rains Diamonds Sometimes in Indiana.**

COLUMBUS, Ind., Dec. 8.—Diamonds have been reported found in Brown County. After a heavy rain which recently fell G. T. Staples, an optician there, picked up a couple of them in an alley in Georgetown. He sent the purest of the two to a lapidary in Philadelphia, who cut and polished it, and then pronounced it a diamond of great purity.

States Attorney William Waltman, who has just returned from Brown County, reports considerable excitement over the affair. Staples will set the diamond in a ring made from Brown County gold and present it to his daughter.

**James V. Ridgway Will Get His Salary.**

CHICAGO, Ill., Dec. 5.—In the United States Circuit Court, the petition of James V. Ridgway against Giles, Bro. & Co. came up, and Judge Grosscup decided that under the contract, dated Jan. 1, 1891, entered into between the petitioner and Giles, Bro. & Co., and which continued until the firm went into the hands of a receiver, Ridgway was entitled to a decree for the amount of his salary, at \$7,500 a year, from April 25 to December 31, 1893, less amount of credits. The balance due Ridgway is \$3,423 90, with interest, and the receiver is directed to pay the same.

Johnson Bros., Canton, S. Dak., have suspended business on account of financial difficulties.

ESTABLISHED 50 YEARS.

LANDEL, BAREMORE & BILLINGS,

IMPORTERS OF

DIAMONDS,

AND OTHER PRECIOUS STONES.

FINE PEARLS A SPECIALTY.

MANUFACTURERS OF

DIAMOND JEWELRY,

IN THE LATEST DESIGNS.

Diamonds Recut in Modern Styles or Repaired on Premises.

58 Nassau Street,  
29 Maiden Lane,  
NEW YORK.

1 Tulp Straat,  
AMSTERDAM.

1 St. Andrews St.,  
Holborn Circus,  
LONDON, E. C.



ESTABLISHED 1841.

CARTER, SLOAN & CO.,

MANUFACTURERS OF GOLD JEWELRY,

No. 15 MAIDEN LANE,

NEW YORK.

A. CARTER JR.  
A. K. SLOAN.  
C. E. HASTINGS.

GEO. R. HOWE  
WM. T. CARTER  
WM. T. GOUGH.

FACTORY, NEWARK, N. J.



JOHN N. DISSELKOEN,

Gutter and Importer of

DIAMONDS

FACTORY  
73 LANGEBLEEKERSPAD  
AMSTERDAM.

19 East 16th St.,  
NEW YORK.



### Sensational Arrest of Joseph Rundbach and Wm. Dattelbaum.

Joseph Rundbach, retail jeweler of 2168 Third Ave., New York, whose assignment was chronicled in these columns last week, has been indicted for grand larceny and held in \$5,000 bail Wm. Dattelbaum, of Dattelbaum & Friedman, 4 Maiden Lane, was indicted at the same time on the charge of collusion and released in \$2,500 bail.

The circumstances which lead to the indictments were these: As told in THE CIRCULAR last week, Rundbach's attorney offered at the creditor's meeting held Nov. 29th to settle at 50 per cent. though he said the assets were but \$500, and the liabilities \$11,000. The committee appointed to act for the creditors consisted of Wm. I. Rosenfeld, 8 Maiden Lane, one of Rundbach's largest creditors, chairman, Harry Oppenheimer, of H. Z. & H. Oppenheimer and H. M. Condit, secretary of the New York Jewelers' Board of Trade. They suspected dishonesty and decided to unearth it if possible. After consultation with Samuel Greenbaum, of the law firm of Hays & Greenbaum, 170 Broadway, a detective was employed to watch Rundbach who was supposed to have left the city.

It was discovered that on the night preceding the failure Rundbach had gone to the Hotel Wellington and registered as H. M. Meyerhoff, of New Haven. A large trunk arrived soon afterward, and he locked it up in his room. On Dec. 3d the detective saw Rundbach and another man buy two valises in a Third Ave. store, and, after going to Rundbach's room, carry the satchels to a flat occupied by William Dattelbaum, at 25 E. 106th St. Mr. Rosenfeld, chairman of the creditors' committee, obtained warrants for Rundbach and Dattelbaum in the Tombs on Tuesday, and also got a search warrant for Dattelbaum's flat. The deputy sheriffs had, meanwhile, seized the trunk in the Wellington and found it empty.

Accompanied by Roundsman Campbell

and Detective O'Connor, Mr. Rosenfeld went to Dattelbaum's flat on Tuesday evening. To their demands for the secreted goods, after much pleading, Mrs. Dattelbaum gave up two satchels filled with jewelry which were hidden under the bed. The detective searched and found in her trunk 60 watches. These, Mr. Rosenfeld told a reporter, were done up in the package they were in when Rundbach purchased them from Jules Racine & Co., 180 Broadway. Mr. Dattelbaum, who arrived as the search was going on was then arrested.

An hour or two later Rundbach was taken into custody at his home, 4 Lincoln Place. The men and jewelry were taken to the Tombs Court, Wednesday morning. Dattelbaum was discharged, and Rundbach was held in \$500 bail for examination. The next day, Thursday, however, Mr. Rosenfeld presented his evidence to the Grand Jury, who found indictments against Rundbach and Dattelbaum, the former for removing and the latter for concealing property for the purpose of defrauding creditors. Judge Martine issued the warrant for the arrests and as before stated Rundbach's bail was fixed at \$5,000 and Dattelbaum's at \$2,500. A meeting of Rundbach's creditors was held Thursday afternoon and a report of what had been done submitted by the committee who were continued in office and given full power to act for the creditors.

Mr. Rosenfeld, who was seen at his office, 8 Maiden Lane, Friday, stated to a CIRCULAR reporter that the cases against Rundbach and Dattelbaum would be pushed to the bitter end. The creditors, he said, would attempt to put a stop to dishonest failures of this kind by making an example of these two men. The value of the goods recovered he put at about \$2,000 or \$3,000.

Among the creditors are L. Tannenbaum & Co., H. E. Oppenheimer & Co., Morris Kollender, Jules Racine & Co., H. Z. & H. Oppenheimer, Wm. I. Rosenfeld, Dattelbaum & Friedman, Chas. F. Wood & Co.,

and R. A. Breidenbach. Two motions to vacate the attachments against Rundbach obtained by Lippman Tannenbaum and Morris Kollender, were argued Thursday before Judge Van Wyck of the City Court. Both motions were denied with \$10 costs.

### Proceedings of the Jewelers' League.

The regular monthly meeting of the executive committee of the Jewelers' League was held on Friday, Dec. 7th. The minutes of the previous meeting were read and approved. Five requests for change of beneficiary were received and granted, and the following applicants were admitted to membership:

Section A.—Elsworth G. Hoover, Harrisburg, Pa., recommended by C. H. Higbee and E. W. Drury.

Section A.—Harry W. Hunter, Philadelphia, Pa., recommended by A. E. Tyson and C. H. Higbee.

Section A.—Chas. M. LaRue, Danbury, Conn., recommended by O. W. Swift and J. E. Spencer.

Section A.—Adelbert E. Rogers, Scranton, Pa., recommended by C. H. Higbee and Wm. Pfeiffer.

Section B.—Ira H. Johannes, Washington, D. C., recommended by Galt Bros. and C. H. Higbee.

Section B.—Harry B. Koch, Washington, D. C., recommended by Wm. Friederick and C. H. Higbee.

Section B.—Everton B. Powell, Washington, D. C., recommended by A. D. Prince and Julius Aderer.

The next meeting will be held Friday, Jan. 4th, 1895.

M. C. Nettleton, of Albuquerque, N. Mex., one of the oldest jewelers in this Territory, surprised the business circles recently by making an assignment to his sister-in-law, Mrs. H. S. Nones, to whom, it is said, he owes at least \$4,000. He claims bad collections and dull trade as responsible for his assignment.

ESTABLISHED 1843.

Highest Awards in Every Competition

LEROY W. FAIRCHILD & Co.,  
3 Maiden Lane, New York City.

Gold Pens, Gold and Silver Pencils and Pen Cases,

The Handsomest and Cheapest Line of Goods in the Market.

WORKS: 3D AVENUE AND OGDEN ST., NEWARK, N. J.

# Reduced Prices—"H. H. Taylor" Grade Elgin Movements.

TAKE ADVANTAGE OF THIS CHANCE TO MAKE A GOOD PROFIT.

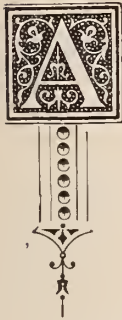

AFTER thirty years' trial, the "TAYLOR" movement has proved unexcelled as a Timekeeper.

We will close out our stock at 25 per cent. reduction from old prices.

**SEND US YOUR ORDERS BEFORE ALL ARE SOLD.**



NEXT to the "B. W. RAYMOND" the "TAYLOR" is the Best Grade 18 Size Elgin Movement.

The "Elgin Watch Co." have discontinued the Taylor Movement.

**SEND US YOUR ORDERS BEFORE ALL ARE SOLD.**

**H. H. TAYLOR MOVEMENT.**

- |                                                                       |                                                    |
|-----------------------------------------------------------------------|----------------------------------------------------|
| H. H. Taylor, Gilded, 15 Jeweled, adjusted, Hunting or Open Face..... | No. 33, Nickel, 15 Jeweled, adjusted, Hunting..... |
| H. H. Taylor, Nickel, 15 Hunting Only.....                            | No. 80, Gilded, 15.....                            |
| No. 76, Gilded, 15 Jeweled, adjusted, Open Face.....                  |                                                    |

**BENJ. ALLEN & CO.,** (Publishers of the B. A. & Co. Catalogue.) **CHICAGO, ILLS.**

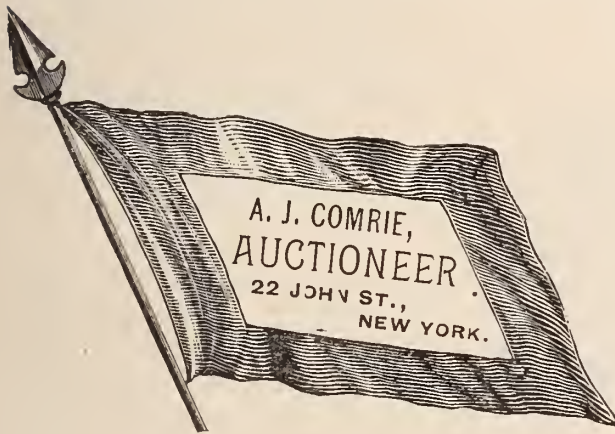

SPECIAL SALESMAN OF  
**WATCHES, DIAMONDS,**  
Bric-a-Brac  
and Art Goods  
FOR  
Established Jewelers.

WRITE FOR PARTICULARS.

Communications Strictly Confidential.

References given in all parts of the United States from Retailers and Jobbers.

**CROUCH & FITZGERALD.**

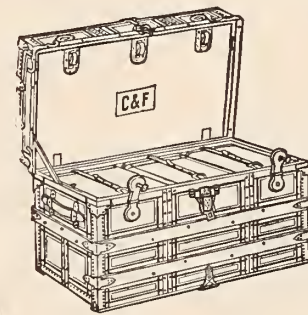

Jewelry Trunks and Cases,  
161  
Broadway,  
Bet. Cortlandt and  
Liberty Sts.,  
888 B'way,  
701 6th Ave.,  
NEW YORK.

**FLAT WARE AND HOLLOW WARE STAMPED**



IS THE GENUINE.  
Manufactured by  
**WM. ROGERS M'F'G CO.,**  
HARTFORD CONN.

**Philadelphia College of Horology**

Is not the largest but is the finest school in the country. A practical school to learn watch-making, engraving, and jewelry repairing. One tuition pays for all branches. Send for prospectus.

**F. W. SCHULER, PRINCIPAL.**

1213 Filbert St., Philadelphia, Pa.

Write for particulars of our corresponding course.

**DON'T FORGET THE JEWELERS' CIRCULAR PUBLISHING CO.'S BOOK LIST** when in want of any technical book in the Jewelry or Kindred Trades.

**Jules Jürgensen**

OF COPENHAGEN.

The reputation these watches have maintained for Fifty Years has never been equalled, being made on strictly scientific principles and no expense spared to give the Best results in mechanism and timekeeping qualities.

SOLE AGENTS,

**John C. Hyde's Sons,**  
NO. 22 MAIDEN LANE.

**THE AMERICAN KNIFE AND SCISSORS SHARPENER.**

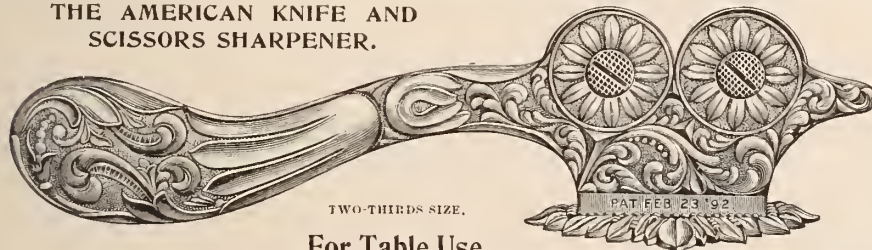

For Table Use.

Special Inducements to Jobbers

... Manufactured only by the

**MOSSBERG WRENCH CO.,**  
ATTLEBORO, MASS.

Makers of **Novelties in Silver and Hardware.**

**Practical and Handsome.**

A Silver Plated Knife and Scissors Sharpener, retailing at a popular price. Perfect in action, nothing to wear out. Cutting discs of finest hardened steel. An ordinary sharpness or a RAZOR EDGE can be acquired in a few moments.



TWO-THIRDS SIZE.  
FOR DESK USE.

- FOR SALE BY**
- Benj. Allen & Co., Chicago, Ill.
  - F. M. Sprockmule & Co., "
  - G. A. Webster, "
  - L. Straus & Sons, New York
  - E. G. Webster & Son, "
  - Oskamp, Nolting & Co., Cincinnati, O.
  - Baldwin, Miller & Co., Indianapolis Ind.
  - Eliassof Bros. & Co., Albany, N. Y.
  - Thos. Long & Co., Boston, Mass.
  - Smith & Patterson, "
  - Dame, Stoddard & Kendall, Boston, Mass.

# THE BOWDEN SEAMLESS RING

IS MADE ONLY BY

## J. B. BOWDEN & Co.,

Makers of Finger Rings of every Description.

REMOVED FROM BROADWAY AND JOHN STREET,

### TO 3 MAIDEN LANE,

NEW YORK.

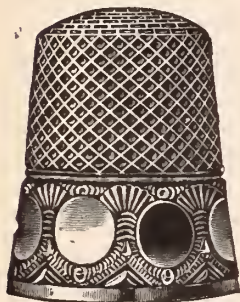

KETCHUM & McDOUGALL,  
MANUFACTURERS  
GOLD & SILVER THIMBLES,  
GOLD COLLAR BUTTONS,  
AUTOMATIC EYE-GLASS HOLDERS  
198 BROADWAY N. Y.



ILLUSTRATED CATALOGUE SENT ON APPLICATION

## HAVE YOU RECEIVED OUR PRICE LIST? OF DIAMOND MOUNTINGS.

If not, send your business card and we will send you one.

**LEONHARDT & CURRAN,**



Manufacturing Jewelers  
OFFICE AND FACTORY,

57 Maiden Lane, New York.

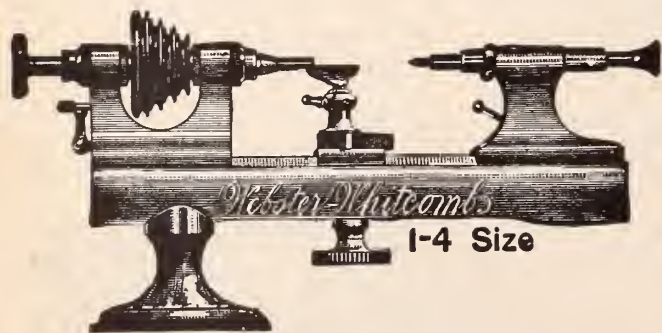

STRONGEST GUARANTEES.

Quality Maintained.

Prices to Suit the Times.

Ask for our New Prices and Terms for 1894.

## American Watch Tool Company,

Chymistry Dist., Waltham, Mass.. Stoney Batter Works.

### The Strike of the Diamond Polishers and Setters Ended.

The strike of the diamond polishers and setters of New York ended last week. By Wednesday all the men in the cutting establishments affected, with the exception of a few in the Mendes Cutting Works, 51 Maiden Lane, were back at work. The report that Arbitration Commissioner Sweeny had arranged a compromise by which the employes were to receive an advance, was denied by all the employers whom THE CIRCULAR reporter saw.

Every firm with the exception of Stern Bros. & Co. stated that the men had returned to work at the old schedule. This firm said that a slight advance on small stones was granted to polishers. This, however, they claimed they were willing to accede to before the strike commenced.

### The Death of Albert D. Holt.

PROVIDENCE, R. I., Dec. 5.—At a late hour yesterday the grim messenger of Death summoned to his final resting place another of those who for nearly a quarter of a century has been actively and prominently identified with the jewelry business of this city. Albert D. Holt.

Mr. Holt was born in England 51 years ago. After acquiring a good education in his native land he learned the machinist's trade and became very proficient, especially upon braiding machinery. Accordingly upon arrival in this country he obtained employment at the Buckeye Mowing Machine Co., in this city. After a short period he removed to Attleboro Falls, and accepted a prominent position at Doggett's braid factory.

The machinist's trade not proving lucrative, about 1873 he entered the manufacturing jewelry establishment of B. S. Freeman & Co., Attleboro Falls, where he was employed as a general utility man about the shop. Among his occupations was that of drawing down wire.

While engaged with Messrs. Freeman & Co., his father died and Mr. Holt fell heir to a large sum of money. With this he engaged in business for himself, and chose the plating branch of the jewelry industry. Providence seeming to afford a better field for his operations, he came to this city and commenced the plating business in 1880 in a small shop at 9 Calendar St. By untiring efforts he soon developed a volume of business that about a year later necessitated his removing to a larger shop at the corner of Dorrance and Clifford Sts. He formed a co-partnership with Henry Davenport and Joseph Weaver, and later with Silas E. Field. A successful and prosperous business was built up and in July, 1891, Mr. Holt purchased the entire business and since that time has conducted the business alone. For three or four years the firm became interested in the manufacturing jewelry business but soon withdrew therefrom.

### The Death of Bartlett Smith.

Bartlett Smith, founder of the firm of B. & W. B. Smith, manufacturers of jewelers' store fixtures, died at his residence, 154 W. 121st St., New York, Friday morning. His death was due to paralysis, the first stroke of which he received about three weeks ago.



THE LATE BARTLETT SMITH.

Bartlett Smith was a native of the old South, being born near Norfolk, Va., 77 years ago. Here as a boy he learned his trade as carpenter and cabinet maker, and going to New York about 1837, commenced practising his vocation. His work proved remunerative, and in 1846 he established a shop on W. 21st St. Ten years later he moved to the present location of the shop, 220 W. 29th St. Here he continued alone, doing all kinds of work, working until 1878, when his son, Wm. B. Smith, who had patented the perpendicular sliding showcase now universally used by jewelers, was admitted to partnership. The new firm was known as B. & W. B. Smith, and immediately started to make a specialty of fine store fixtures, particularly those desired by jewelers. By their many innovations and excellent work they soon became known throughout the entire jewelry trade, and their business grew rapidly.

Seven years ago Mr. Smith retired from active business and his second son, Jacob W. Smith was admitted to the firm. These two sons now continue the business as before under the old firm name. Bartlett Smith was also well known as a builder, being one of the pioneers in building in his section of Harlem. He was a member of no organization, but gave his spare time, particularly since his retirement from active business, to church and charitable work. He was an ardent churchman all his life, and was one of the founders of the Calvary Methodist Episcopal Church at 129th St. and Seventh Ave. The funeral, which took place at this church, Monday evening, was largely attended. The remains were interred at Woodlawn Cemetery.

### A. B. Kapp Puts His Head into the Noose.

PROVIDENCE, R. I., Dec. 4.—Albert B. Kapp, who previous to last April conducted a retail jewelry business as A. B. Kapp Manufacturing Co., 531 Broadway, New York, was arrested in the Union Depot, this city, last night at the instance of William R. Dutemple & Co.

Kapp commenced his business career as a clerk in a New York dry goods house and a few years ago went to Mineral Springs, Tex., where he started in business for himself. In 1888 he returned to New York and engaged in several business ventures, finally in February, 1892, starting in the jewelry business as A. B. Kapp & Co. Last Spring he changed the style of the concern to the A. B. Kapp Manufacturing Company and in March visited the manufacturers in this city and the Attleboros. His mission here was to purchase a supply of jewelry and during his stay here he called upon a large number of the manufacturers, purchasing from each bills amounting to from \$100 to \$400.

On April 6 he made a bill of sale to a Philadelphia party, so that when Kapp made an assignment ten days later, there were no assets to be found, nothing but an empty desk remaining on the premises. Since then, in vain, have the local manufacturers been endeavoring to collect their bills against Kapp. Early this Fall he blossomed out as a representative of the Empire Jewelry Co., of New York, and last week visited this city to make purchases in their interest. He called upon Wm. R. Dutemple & Co., to whom he was owing a bill of \$63. Kapp was informed that he had been black-listed by the Manufacturing Jewelers' Board of Trade, and that the members of that association had voted not to sell him any more goods. Highly indignant at this information Kapp paid a visit to Secretary Morton, of the Board, but obtained no satisfaction. He was shadowed in his calls at other manufacturing concerns, and eventually went to the railroad depot, where he purchased a ticket for Attleboro.

Immediately after Kapp left his office, Secretary Morton called in the services of Sheriff Blanchard and placed in his possession for service a writ of arrest against Kapp. Upon this writ Kapp obtained bail, but before he could leave the city two more writs were served and he was taken to the Providence County jail at Cranston and locked up. Kapp telegraphed to a responsible party in Philadelphia and word was at once sent to Providence to have the Merchants' National Bank furnish the bonds to the extent of \$2,000. For this purpose cashier John W. Vernon of the bank started this noon for Cranston, but the officers of the Board of Trade got wind of the intended release and they too started for the jail.

It was a race to get to the jail first and Secretary Morton won. Sheriff Viall was given a bundle of writs and they were served immediately upon Kapp, while several others were held in reserve to hold the

debtor, if bail was obtained on the first writs. Additional writs to the number of 35 have been served, at the instance of R. L. Griffith & Son, Lothrop & Livesay, Watson, Newell & Co., of Attleboro; Royce, Allen & Co., Fletcher, Burrows & Co., H. N. Pervear Co., E. I. Franklin & Co., of North Attleboro, Oscar M. Draper, of North Attleboro; J. C. Cummings & Co., of Attleboro; W. E. Webster & Co., T. I. Smith & Co., of North Attleboro; George W. Cheever & Co., of North Attleboro; Waite, Mathewson & Co., The Waite, Thresher Co., George K. Webster, of North Attleboro, Parks Bros. & Rogers, George B. Willis & Co., J. G. Fuller & Co., P. & A. Linton, W. H. Wilmarth & Co., of Attleboro, Read & Lincoln, A. A. Bushee & Co., of Attleboro, The Ostby & Barton Company, S. O. Bigney & Co., of Attleboro, Short, Nerney & Co., of Attleboro, Barstow & Williams, H. Wexell & Co., Attleboro, Bowes & Crandall, Irons & Russell, R. D. Horton & Co., Dewey F. Adams, J. T. Inman & Co., Williams & Payton, S. & B. Lederer, R. L. Moorhead & Co., and Bennett, Melcher & Co. There are about a dozen other writs to serve.

..... A .....

## Selling Novelty

Small Cups and Saucers, with Sterling Silver Spoon, that can be retailed complete, with ribbon, for

**\$1.00**



Our price to the Jewelry Trade,

**\$8.00** per dozen,

IN FULL DOZEN LOTS.

Send \$8.00 with order to save time. Cups and Saucers are assorted styles and decorations.

## LEVY, DREYFUS & CO.,

9 & 11 Maiden Lane, New York.

**\$50.00** will buy an opening stock of Porcelain Novelties. Order promptly to get them in time for Christmas trade. Selection may safely be left to us. Send money with order if we do not know you.

## THE EATING OF THE ORANGE.

DAINTY DEVICES FOR THE PROPER EATING OF THIS DELICIOUS AND SEASONABLE FRUIT.

THE present is, perhaps, the best orange season that dealers in the fruit trade ever remember having had. Oranges medicinally as a tonic and for their refreshing properties as a fruit grow steadily in favor from year to year as the public learns more and more to appreciate the fruit's manifold good qualities. Advanced orange lovers have even taken up an "orange cure" which necessitates the consumption by the patient of anywhere from one to three dozen oranges daily, but which is said to remove from its disciples all bodily pains

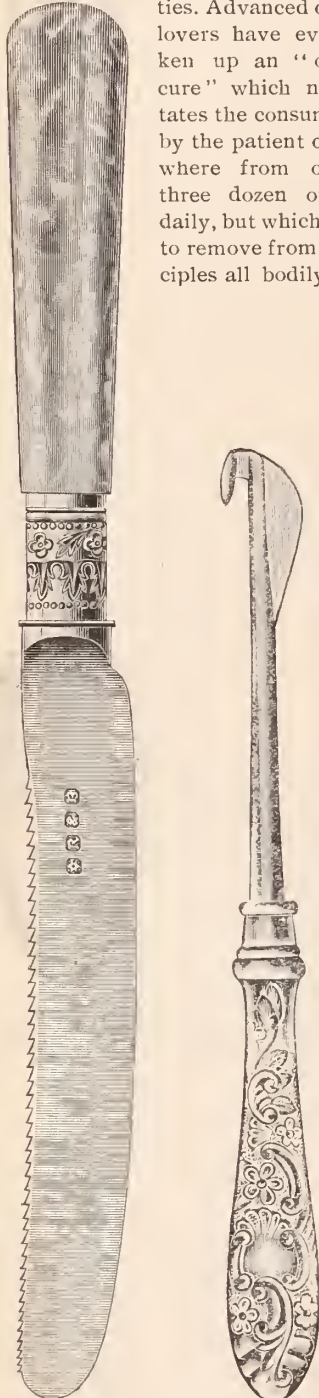

ORANGE KNIFE. ORANGE PEELER.  
ROGERS & BROTHER.

and ills and to leave the system in a particularly clean and healthy condition.

The method of eating the orange varies

with the locality, the most primitive being to puncture a small hole in the stem end and extract the juice by combined pressure and suction. Perhaps the daintiest and certainly the most clean way, is to divide the unpeeled fruit transversely into halves and extract the succulent pulp from the golden carpel by means of an orange spoon, the bowl of which is suitably shaped for the purpose. Herewith are illustrated some of the best thing in orange holders, orange sets and orange spoons as made in silver plate.

The invention of the orange holder is probably due to the genius of F. F. Heilborn, of Plainville, Mass., father or Mr. Heilborn, of Coddling Bros. & Heilborn, North Attleboro, Mass.

### ORANGE PEELER.

The orange peeler here illustrated is a practical novelty which has been conceded by all who have used it to be perfect in its operation, neatly removing the peel without soiling the fingers. It is made in table and pocket sizes, and in assorted patterns and finishes. The table size is put up by Rogers & Brother, six in a plush lined paper box, while pocket size is put each in a leather sheath in a paper box.

This device is used in the following manner: The peeler is held in the right hand, the orange in the left; with thumb of the right hand on the orange with the flat face of the hook placed square on the orange, the pressure is drawn enough to insert the hook in and under the peel, the orange being revolved in the left hand, the peeler being drawn in the opposite direction until the peel is cut into as many sections as desired, when, it may be easily removed by inserting the back of the peeler under the loose point of the section. The blade on the back of the peeler is useful for removing the soft white under skin.

These useful patented articles are for sale by others besides Rogers & Brother, 16 Cortlandt St., New York, who have a fine assortment of them.

### ROGERS' ORANGE KNIFE.

Among the most practical and desirable articles produced for the proper eating of the orange is the orange knife illustrated here, first introduced by Rogers & Brother, the makers of the celebrated ★ Rogers & Bro. A1. brand of electro silver plated flatware, 16 Cortlandt St., New York. The essential feature of the device is the saw back; the cutting edge is retained, making the knife adapted to the requirements of an all round fruit knife. The handles come either in pearl, ivoride or plated silver. The firm have had a great sale of this knife as well as of their orange sets, comprising 1 knife and 1 spoon, or 6 knives and 6 spoons, put up in plush lined boxes.

### MAJESTIC ORANGE SPOON.

The handsome and tasteful pattern here illustrated is the Majestic made by Rogers & Hamilton, Waterbury, Conn. The peculiar



MAJESTIC ORANGE SPOON.  
ROGERS & HAMILTON CO.

construction of the bowl yields a shape which fits the carpel of the orange perfectly, removes cleanly and deftly every particle of pulp and gives great strength to that portion of the spoon at the junction of the bowl and handle where this is most desirable. The spoons are put up in sets of half a dozen, each packed in beautifully lined fancy boxes, and as will be seen by reference to the firm's advertisement on another page, a particularly liberal offer is made to every jeweler who reads these lines. These spoons similarly put up may also be had in the Monarch, the Shell or the Cardinal patterns, all popular and salable designs.

### HOLMES & EDWARDS' ORANGE GOODS.

In an accompanying illustration is depicted one of the orange sets made by the

# SPECIAL OFFER No. 7.

TO ANY JEWELER IN THE UNITED STATES WHO SENDS US

## One Dollar==\$1.00

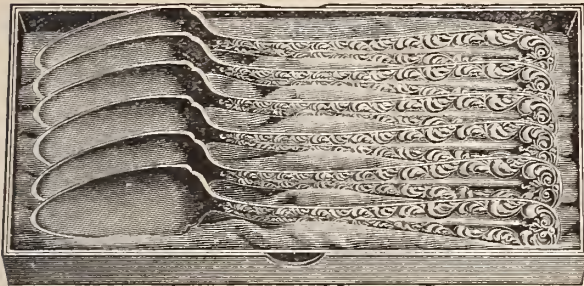

We will deliver, via registered mail,

ONE SET OF **Six Orange Spoons.**

No more than one set to any dealer at this price.

Six Majestic Orange Spoons, (reduced size) in Fancy Lined Box, List, \$6.00 per doz.



SHELL ORANGE SPOON---Full Size.



SHELL.

MONARCH.

CARDINAL.

MAJESTIC.

### CONDITIONS:

SIMPLY WRITE US THE PATTERN YOU DESIRE AND MENTION OFFER No. 7. INCLOSE CASH, ONE DOLLAR (\$1.00) (OR ITS EQUIVALENT) AND BUSINESS CARD, OR SOME PRINTED MATTER TO SHOW US YOU ARE A DEALER, THEN ADDRESS IT PLAINLY TO

THE ROGERS & HAMILTON Co.,  
WATERBURY, CONN.

**EXPLANATION**==WE OFFER ONE SET (ONLY ONE) BELOW COST.

FIRST:--TO TEST *THE JEWELERS' CIRCULAR* AS AN ADVERTISING MEDIUM.

SECOND:--TO INTRODUCE OUR UNEXCELLED ORANGE SPOON BOWL, WHICH HAS PROVED TO BE THE MOST PRACTICAL OF ANY YET INTRODUCED.

## THE ROGERS & HAMILTON CO.

Manufacturers of the

HIGHEST GRADE SILVER PLATED FLAT WARE,

Waterbury, Conn.

Holmes & Edwards Silver Co., Bridgeport, Conn. Another set containing half a dozen each of knives and spoons is shown in

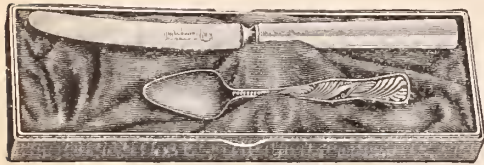

ORANGE SPOON AND KNIFE.  
HOLMES & EDWARDS SILVER CO.

their advertisement. In the sterling silver inlaid line the goods may be had in the Warner, Waldorf, Minnehaha, Hiawatha, pearled antique and Windsor patterns. The knives are of non tarnishable Wessell silver with celluloid handles and the sets are packed in satin lined heavy leatherette cases. In regular plated ware the orange sets may be had in the following popular patterns: Triumph, Rialto, Greek, Shell, Perfect and Delsarte. The scimitar bladed knife which many people prefer, is put up in these latter sets.

THE WILCOX ORANGE HOLDER.

In the orange holder illustrated herewith, the manufacturers, the Wilcox Silver Plate Co., Meriden, Conn., believe they offer the trade one of the best things in its line. The half orange is fastened in the receptacle by

the base by a swivel which admits of the orange being held at an angle for convenience in eating.

MERIDEN BRITANNIA CO.'S SAVOY.

In their handsome Savoy the Meriden Britannia Co., Meriden, Ct., have a pattern which has found great favor in the eyes of buyers. The orange knife is furnished with a serrated edge for convenience in dividing the fruit and the artistic shape of the spoon's bowl is excellently adapted to the purpose



ORANGE CUP. PAIRPOINT MFG. CO.

for which it is intended. In combination the two pieces make a most attractive appearance.

THE PAIRPOINT CO.'S  
ORANGE HOLDER.

The holder which is the subject of above illustration has had a wide publicity given it thanks to its many good qualities. It is made in several patterns, all excellent and has proved an excellent seller. The illustration makes further description unnecessary but dealers who carry the article in



ORANGE CUP. WILCOX SILVER PLATE CO.



a half turn against the curved prongs shown at the bottom. The cup is connected with

stock will find it profitable. A dainty little booklet on orange goods will be mailed on

application to the company.

WM. ROGERS MFG. CO.'S COLUMBIA.

A dainty set put up by the Wm. Rogers Mfg. Co., Hartford, Ct., is the Columbia. The pattern will commend itself to all who do not already know its good selling qualities. The knife blade has a serrated edge and will be found useful not only for dividing oranges but also for bananas and



SAVOY ORANGE SPOON AND KNIFE.

MERIDEN BRITANNIA CO.

other thick skinned fruit. In orange spoons the company offer a handsome assortment of patterns with both plain gilt bowls.

## The Conception of the Orange Spoon

WAS ONE OF THE BRIGHT IDEAS OF  
**THE HOLMES & EDWARDS SILVER CO.**

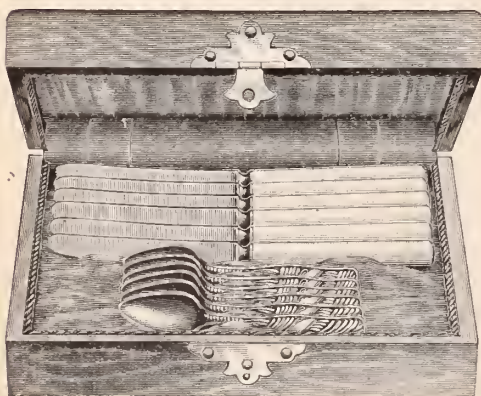

THE HOLMES & EDWARDS SILVER CO., Bridgeport, Conn.

Our line of ORANGE SETS, ORANGE SPOONS, ETC., in Sterling Silver Inlaid and "XIV" quality plate, is the standard of reliability. No finer goods are put on the market, than by us.

OUR NEW YORK SALESROOM,

No. 2 MAIDEN LANE,

Second door from Broadway, is showing a fine line of

Sterling Silver, Hollow and Plated Ware.

ANTIQUE OAK CASE, CONTAINING 6 WARNER INLAID ORANGE SPOONS AND 6 WESSEL SILVER ORANGE KNIVES.

SEND FOR SPECIAL PRICES.



A. A. WEBSTER'S CUPS.

Our design shows the style of orange cup offered by A. A. Webster, 30 East 14th St.,



ORANGE CUP.

A. A. WEBSTER.

New York. The jointed rim holds the orange securely in place and facilitates its

eating. These cups are made by Mr. Webster in sterling silver, decorated china, quadruple plate and glass. An illustrated descriptive price list will be mailed on application.

The illustration here shows a pretty orange set of C. Rogers & Bros., Meriden, Conn.

orange spoon is in the Regent pattern and is very pretty. Both patterns are patented. These orange sets are put up with various kinds of knives, plain or etched handle, solid steel knives, pearl handle, and hollow handle. The firm also use German silver orange knives in various patterns.



ORANGE SET. C. ROGERS & BROS.

It consists of an orange knife and spoon, the latter being in the Imperial pattern. These dainty pieces are put up in a plush lined paper box as shown. The firm's latest

Among the orange eating devices on the market, one of the most popular is the orange holder of the Middletown Plate Co., Middletown, Conn. It is dainty and practical.

# ORANGE CUPS.

..MADE IN..

STERLING SILVER,

DECORATED CHINA,

QUADRUPLE PLATE,

AND

GLASS with plated rim.



THE PROPER WAY TO EAT AN ORANGE.

This Cup was patented September 19, 1894, and is the only thoroughly practical one made.

SEND FOR ILLUSTRATED PRICE LIST.



A. A. WEBSTER,

30 EAST 14TH STREET,

NEW YORK.

### Tokens of the Season.

A pretty four-page circular is received from J. E. Caldwell & Co., Philadelphia, Pa. It is entitled "A Friend at Your Elbow in Your Christmas Gift-Giving." The circular specifies goods that may be bought for \$1.00 to \$2.50; for \$5, for \$10, and for \$25 to \$100. The articles are conveniently classified, and the person who intends to give presents is sure to find under the various lists, items that will interest him.

\*

Twenty-two leaves of heavy supercalendered paper bound by a silk cord, are devoted to illustrations and reading matter relating to the notable house of Heeren Bros. & Co., Pittsburgh, Pa. The cover is a fine specimen of half-tone engraving, the design being comprehensive and striking. In the center is a bird's eye view of Pittsburgh, in the upper left hand corner is depicted a repoussier at work, in the lower left hand corner is a view of the new and beautiful Heeren building, while the name and address of the firm stand out over all in handsome unique characters. The frontispiece is a duplicate of the advertisement that appeared in the holiday edition of THE CIRCULAR, a half-tone engraving showing characteristic groups of persons representing the various branches of manufacture comprehended in the term jewelry trade. Page 2 gives an historical sketch of the house; page 3 is a group of portraits of the partners, Otto Heeren, Wm. Heeren and Wm. F. Hoffman. The chapter "Past and Present" compares the original mean beginning of the firm with their present magnitude, the illustrations showing Heeren Bros. & Co.'s starting place in 1867, exterior views of their present handsome building, the packing room in the basement, the first floor from the gallery, the material, tool and silverware departments, import department, the factory, displays of marble

statuary, real bronzes, imitation bronzes, art furniture, china, porcelain, bisque and majolica, leather goods and novelties, imported clocks, American clocks, musical boxes, souvenirs. The illustrations are full-page half-tone engravings, and the reading matter is pertinent and interesting.

\*

A device of pasteboard, simulating a miniature mail bag has been issued by Wm. A. Keddie, 14 Maiden Lane, New York. The exterior is a remarkable specimen of lithographing, and the interior contains the holiday announcement of Mr. Keddie, with a list of the 12 birthday stones, and a complete list of precious stones. The circular is sent through the mail by writing the address on the outside and affixing a one cent stamp.

### St. Joseph.

Baldwin & Co. are advertising a closing out sale.

Louis Burnett & Co., Everest, Kan., have removed their jewelry store to a better location in that town.

C. N. McKelvey is conducting an auction to be continued for 30 days. His advertisements read that he will go out of the jewelry business entirely and will devote his attention to the optical business.

### Connecticut.

Frank A. Wallace, Wallingford, is expected home from South Dakota early in February.

Mr. Seely has moved from Forestville to Wallingford, where he will engage in the jewelry business.

Jennings Bros., proprietors of the Bridgeport Silver Plate Co., Bridgeport, have opened a jewelry store at 449 Main St.

Chas. Beach, for many years clockmaker in Bristol, employed in the clock factories

there died on Monday night last, aged 79.

A new building is to be erected by George Sanford, in Thomaston, to be used for the manufacture of clock bells. The shop will be 60 by 20, one and one-half stories high with basement.

The Upson Jewelry Co., Waterbury, have been notified by John Ryan, executor of the O'Connor estate, to vacate their store, 117-119 Bank St., within a few weeks, Mr. Ryan having rented the store to his own shoe firm.

E. A. Locke, formerly secretary of the Waterbury Watch Co., has purchased land on Crescent St., Waltham, Mass., and will build a factory and manufacture watches. The new concern will be known as the Rumford Watch Co.

The new factory of Valentine & Linsley, silver plate goods manufacturers, Wallingford, is nearing completion. The water rent of this concern and of the Biggins & Rodgers Co., is free for five years in consequence of their locating in the town.

A long haired, smoothly spoken, neatly dressed stranger, giving his name as Dr. Wilson, and who created the impression among the up-country people that he was Frederick Wilson, a Bridgeport optician, has been swindling the people north of South Northwalk. A woman gave him \$15 for a pair of worthless spectacles and many of her neighbors showed a disposition to part with their money. Finally Wilson inadvertently disclosed the fact that he was a fraud, but not until he had disposed of his worthless stock.

### The Sudden Death of Frederick L. Davies.

Frederick L. Davies, a traveler for C. G. Alford & Co., 195 Broadway, New York, and formerly a well-known jeweler of Nashville, Tenn., died suddenly in Evansville, Ind., Saturday, from the effects of an operation. He was taken ill while stopping at the St. George Hotel, Friday, and was removed to a hospital, where he died the following day.

Mr. Davies began business in Nashville in 1865, and with his brother, Wm. H. Davies, conducted the firm of F. L. Davies & Bro. Wm H. died in September, 1891, and Frederick L. Davies continued alone until the latter part of 1892, when he went out of business. He was subsequently employed by various jewelry houses until last August, when he became a traveler for C. G. Alford & Co., taking Tennessee, Kentucky, Indiana and Georgia.

Mr. Davies was about 60 years old. He was a widower, and leaves two grown children, a son and daughter. The remains were sent to his late home in Nashville.



## REORGANIZATION SALE OF Opera and Field Glasses.

We have for immediate sale the largest and best selected stock of Opera and Field Glasses in this country, and offer them at fully 25 per cent. below cost. A few specimen items:

- 75 Non-Achromatic Field Glasses**, 24 lines objective, in case,  
REGULAR PRICE, \$3.25, REDUCED TO.....\$2.00
- 50 Colmont Field Glasses**, 26 lines objective, in case,  
REGULAR PRICE, \$6.00, REDUCED TO.....\$4.90
- 85 Non-Achromatic Opera Glasses**, 15 lines objective, in case,  
REGULAR PRICE, \$9.00 per doz., REDUCED TO.....\$5.25 per dozen
- 50 Achromatic Opera Glasses**, leather covered and japanned, 15 lines objective, in case,  
REGULAR PRICE, \$1.75 each, REDUCED TO.....\$1.35 each.
- 50 Achromatic Opera Glasses**, leather covered and japanned, finer quality, 12 lines objective, in pocket book case, REGULAR PRICE, \$2.25 each, REDUCED TO.....\$1.55 each.
- 40 Achromatic Opera Glasses**, pearl covered, 15 lines objective, in case,  
REGULAR PRICE, \$3.75 each, REDUCED TO.....\$2.90 each.
- 36 Achromatic Opera Glasses**, pearl covered, 17 lines objective in case,  
REGULAR PRICE, \$4.50 each, REDUCED TO.....\$3.70 each

—SEND FOR SAMPLES.—

**QUEEN & CO., Opticians,**

1010 Chestnut St., Philadelphia.

J. G. GRAY, Assignee.

Chatelaine pins of silver in Italian designs are intended for carrying the tiny silver and crystal watches now so fashionable.

### Death of George H. Richardson.

George Henry Richardson, the senior partner of J. W. Richardson & Co., New York and Providence, R. I., died Sunday evening at his home, 576 Washington Ave., Brooklyn. His death was not unexpected, and was due to locomotor ataxia, which first manifested itself last June.

Mr. Richardson was the son of J. W. Richardson, the founder of the firm, who were among the largest manufacturers of emblem goods in the country. Geo. H. Richardson was very prominent in business, social and Masonic circles. He was born in Providence in 1848. When about 21 years of age he became a partner in his father's business and went to New York where with F. S. Slack, another partner, he took charge of the New York office.

When J. W. Richardson died some 14 years ago, Geo. H. Richardson and A. B. Gardner who had become a partner at Mr. Slack's death, continued the business until last February when Mr. Gardner retired. Mr. Richardson then admitted as partners, Harry H. Butts and Wm. H. Morris, still retaining the old firm name. The name and business will now be continued by these gentlemen.

Mr. Richardson was widely popular and was a member of numerous organizations and clubs. Prominent among the latter were the Oxford, and Aurora Grata club of Brooklyn and the Long Island Country Club. The deceased was a 32d degree mason, a member of the Anglo-Saxon Lodge 137, and Clinton Commandery No. 14. He was a member of the Aurora Grata and all the Scottish Rite bodies in which he had also taken the 32d degree. He was a member of the Kismet Temple Mystic Shrine, and of the Masonic Veteran Association of Brooklyn.

The deceased leaves a widow but no children. The funeral services were held last evening at the residence in Brooklyn.

### Some More Details of the Failure of the Lombard Loan Co.

The claims against Jacob L. Salomon and Adolph Mendelsen, proprietors of the Lombard Loan Co., San Francisco, Cal., whose failure was announced in last week's CIRCULAR, aggregate nearly \$90,000, and the assets in sight are valued at \$13,000. The eastern debts foot up \$52,000, the largest creditors being Goodman Bros. and Schorerling, Daly & Gales. The creditors in San Francisco and the east number about 30.

The receiver says his inventory shows the stock remaining in the store is worth \$13,000 according to the invoices. A forced sale will bring more than half this amount.

There is a civil action between the partners, the result of which will be practically equivalent to going into insolvency. J. L. Franklin, of Franklin & Metzger, is receiver, his bond being \$15,000. He himself is a creditor of the firm for \$2,000,

### Boston.

M. Benjamin has taken the old stand of Nathan Baer and restocked it with a line of jewelry.

John Dawson, who removed to Montreal about six months ago, has returned to this city and will relocate here.

Announcement is made that the marriage of M. Myers will take place at Augusta, Ga., Dec. 27, the bride being a young lady of that city.

Nathan Baer is convalescent at the hospital and his recovery is now considered only a matter of time. The paralysis which affected his side is gradually leaving him.

Ex-Commodore Chas. F. Morrill has been renominated for his former position at the head of the South Boston Yacht Club, after a year's rest from the somewhat onerous duties of that office.

A. D. Cairns & Co., who have the name of issuing one of the handsomest calendars sent out annually by any Boston business house, are presenting their trade with a beauty again this year, one of the finest they have ever gotten out.

F. L. Sowter, representing the Smith & Spencer Optical Co., Buffalo, N. Y., has been in Boston recently with a view to interesting local opticians in a proposition to remove the works of the concern to this city or some convenient suburb, and enlarge the facilities by an increase of capital and reorganization of the company. The plan has been favorably received by Boston

dealers and action may be taken by them to bring the business to this section before long.

There was a surprising list of buyers in town last week reported by the jobbers, which turned out to be the result of the meeting of Massachusetts retailers. Among the buyers here from other States during the past week were: D. E. Gordon, Hillsboro Bridge, N. H.; E. P. Fisk, Epping, N. H.; James E. Webster, Milford, N. H.; George T. Winn, Windsor, Vt.; William H. Graves, Warren, N. H.; Vivian W. Hills, Norway, Me.; Mr. Murch, of H. L. Parker & Co., Lyndonville, Vt. The latter was here on a restocking trip, the store of the firm having been burned out recently. They have hired the opera house for the holidays and pending rebuilding will conduct a bazaar there.

### A Large Part of the Contents of Henry Boise's Store Carried Off.

OEIWEIN, Ia., Dec. 10.—The jewelry store of Henry Boise, Fayette, was robbed at 2 o'clock this morning of watches and silverware, valued at least at \$5,000, and \$800 in money. There were three men in the plot. Two entered the store while the third waited in a wagon.

The wagon was backed on the sidewalk in front of the store. Entry was made by cutting a plate glass window. The safe was blown open and the contents placed in a sack, the entire operation taking but a few minutes. A posse is in pursuit.



# A. WITTNAUER,



Successor to J. EUGENE ROBERT & CO.,

19 MAIDEN LANE, - - NEW YORK.

## Swiss Watches and Movements

—OF—

ALL DESCRIPTIONS, STYLES AND SIZES

—AND—

IN VARIOUS GRADES.

## SPLIT SECONDS, MINUTE REPEATERS AND NOVELTIES.

### Providence.

J. S. Nuss, Newport, has given a chattel mortgage for \$300.

J. E. McCaffery has started in the retail business at 419 Main St., Pawtucket.

John E. Leonhard has started in the engraving and chasing business at 98 Pine St.

John M. Chandler returned last Wednesday from a five months' trip in the west, in the interest of J. M. Chandler & Co.

Frank E. Farnum, manufacturer of jewelers' small tools, dies, hubs, etc., has started in business at 35 Potter St.

George F. Wheelwright has started in the precious stone setting business at 216 Weybosset St.

Edward F. Presbery, who recently started at 119 Orange St. to manufacture a line of novelties, has given up his venture.

Henry S. Fink, of D. C. & H. S. Fink, who has been confined to his house by an attack of pneumonia, is now convalescing.

S. Cohn & Co. have succeeded Marcus, Natenson & Sharp Co., manufacturers, 67 Friendship St. William Sharp is the company.

Hancock, Becker & Co. have engaged shop room in the new Kent & Stanley Co. building, and will remove thereto about Feb. 1st.

Adolph Lederer, who for some time carried on the manufacturing business at 108 Eddy St., has sold out his business to S. & B. Lederer, and is now in Europe.

Albert Joseph, formerly of Joseph & Greenbaum, Chicago, was in this city and Attleboro the past week, arranging to secure goods to sell on commission.

Charles D. Heaton, for several years in the employ of the Ostby & Barton Co. as tool maker, has started in business of tool making for himself at 19 Page St.

Joshua Gray, who, about a year ago retired from the retail jewelry business, after an active experience of more than half a century, has again entered the field, with headquarters at 446 Pine St.

The entire stock of William L. Ballou & Co., in the retail branch, corner of Westminster and Mathewson Sts., is being disposed of at "half price," by orders of Assignee Johnson, and is to be closed out before January 1.

Henry H. Richardson, one of the pioneer manufacturers of this city, has so far recovered from his recent illness as to be able to be out and about. He is past the four score mark but is still bright, active and strong.

### Canada and the Provinces.

R. Mercer, Seaforth, Ont., has assigned.

F. S. Sherry, representing Jos. Fahys & Co., New York, was in Toronto, last week.

George S. Klein has taken the road with watch materials for P. W. Ellis & Co., Toronto.

Jessie, daughter of James Trotter, jeweler, Galt., Ont., died recently of consumption.

The work of organizing the trade in connection with the Jewelers' Association of Toronto has been postponed until the New Year, owing to the rush of holiday business.

W. J. Arneil, jeweler, Kingston, Ont., well known as a prominent member of the A. O. U. W., Free Masons, and other beneficial orders, died recently, leaving a widow and seven children.

Trade is brisker in Canada than it has been for some time and a more hopeful feeling prevails throughout the country. A good holiday business is anticipated, the principal feature of the situation being the exceptional demand for solid silver goods.

Two of the cleverest gangs of diamond swindlers and safe crackers in the United States have located and four of their number arrested in Montreal, Saturday morning. The arrest was brought about by the shooting down of Constable Curran while shadowing three of the gang Friday night. Complete burglar kits were found on the prisoners. They have succeeded for four weeks in defrauding many leading local merchants out of thousands of dollars. "Baltimore Whity," who shot Constable Curran, is considered a desperado of the worst type, and is heavily shackled.

### Pittsburgh

S. I. Grossman, doing business on Fifth Ave., as "agent" has left the city.

Will Terheyden, formerly partner with J. M. Schaffer, is now with Heeren Bros. & Co.

Louis Tissot, with Heeren Bros. & Co., has gone to Lancaster, Pa., and will be with Ezra F. Bowman & Co.

A large plate glass window, fully insured, in the store of C. Hauch, Smithfield St., was accidentally broken last week.

A. A. Poole and G. V. Brady, both of Washington, Pa., were in the city last week buying holiday goods.

J. Harvey Wattles has removed to his new colonial home on Wallingford St., near Morewood Ave. He has one of the handsomest residences in the East End.

W. J. Johnson and Phillip Gillespie will enter into the wholesale business in the Spring. Their present headquarters are with Corcoran & Vilsack, 101 Fifth Ave.

Chas. T. Ahlborn, manufacturing jeweler, desires THE CIRCULAR to correct an erroneous item published in a contemporary to the effect that he is going out of business. Such a step has not been contemplated by Mr. Ahlborn, and the publication has given him much annoyance.

A rumor has been circulating to the effect that the store of R. L. McWatty & Co. will be occupied by a New York firm and that a large retail store will be in operation. Mr. McWatty denies the story in toto, and states that his storerooms are not even rented.

W. Warren Wattles, representative here for Randel, Baremore & Billings and S. Cottle Co., told THE CIRCULAR correspondent

that the present depression in trade is owing entirely to the Irwin and other "pools." Over a million in good hard cash has been taken out of the city by these pools, and in a city upheld chiefly by the working and middle classes, this loss must be severely felt.

Visiting jewelers in the city last week were: Fred. Kachler, Sharon, Pa.; H. S. Johnson, Apollo, Pa.; E. Kennerdell, Tarentum, Pa.; B. Neville, Dawson, Pa.; N. C. Cochran, Fairmont, W. Va.; L. Furtwangler, Greensburg, Pa.; Wm. Burns, Coshocton, O.; C. L. Clark, Blairsville, Pa.; W. S. Phillips, Mannington, W. Va., and W. F. Brehm, Rochester, Pa.

### Philadelphia.

George P. Kite, Quaker City Watch Case Co., has started on a western trip.

C. R. Smith & Son have announced that they will positively retire on Feb. 1.

E. Bertsch & Co., 146 N. 8th St., are presenting silver plated napkin rings to their Christmas purchasers.

I. Bedichimer has moved into his new quarters at 11th and Sansom Sts. The store is very attractive.

E. Borhek, 628 Chestnut St., denies that he will change his location, as announced in last week's issue.

Execution on a judgment note for \$2,480 was last week issued to Ida M. Snee against Frank H. Hyde, plater, of 236 S. 8th St.

James Horstmann, 8th and Sansom Sts., has been ill for some days with an attack of typhoid fever, and the prospects of his recovery are considered hopeless.

There appears, according to the assignee, an excellent prospect of a speedy adjustment of the affairs of Queen & Co. Meanwhile their large stock has been kept up and orders have been filled as usual. Reductions have been temporarily made in their prices.

Out-of-town buyers here during the past week included: R. G. Porter, Woodbury, N. J.; M. M. Bovard, Manayunk, Pa.; Robert Steel, Hammonton, N. J.; Howard Story, Conshohocken, Pa.; John Fish, Bryn Mawr, Pa.; Howard Fitzsimmons, Westchester, Pa.; C. Rudolph, Wilmington, Del.; John Dewer, Bryn Mawr, Pa.

### Buffalo.

The trial of Rose State, the shoplifter who was caught after taking a roll of diamond rings from the store of T. & E. Dickinson, takes place Dec. 11.

The following out-of-town jewelers were here last week: Mrs. Seneca Baker, Medina, N. Y.; A. G. Kelsey, Medina, N. Y.; E. H. Miner, Canisteo, N. Y.; S. A. Ryan, Dalton, N. Y.; C. R. Dunkin, Middleport, N. Y.; F. L. Nuse, Titusville, Pa.; H. W. Radder, Seneca Falls, N. Y.; F. E. Vining, Cherry Creek, N. Y.; H. D. W. English, Arcade, N. Y.; J. Stapf, Dunkirk, N. Y.; J. Kearney, Medina, N. Y.; R. C. Holmes, Gowanda, N. Y.; J. J. Carr, Suspension Bridge, N. Y.

# The Jewelers' Circular

AND

HOROLOGICAL REVIEW.

PUBLISHED EVERY WEDNESDAY BY

THE JEWELERS' CIRCULAR PUB'G CO.,

189 BROADWAY, NEW YORK CITY.

A JOURNAL DEVOTED TO THE INTERESTS OF JEWELERS, WATCHMAKERS, SILVERSMITHS, ELECTRO-PLATE MANUFACTURERS, AND ALL ENGAGED IN KINDRED BRANCHES OF INDUSTRY.

Our Editorial columns will contain our own opinions only, and we shall present in other columns only what we consider of interest or value to our readers. Advertising matter will not be printed as news.

Advertising rates in THE CIRCULAR are lower, considering the number of tradesmen reached by its large circulation, than in any other jewelry journal.

Notices of changes in standing advertisements must be received one week in advance; new matter can be received up to Monday.

## INFORMATION FOR SUBSCRIBERS.

### Terms of Subscription, Postage Prepaid.

	PER ANNUM.
United States and Canada, - . . .	\$2.00
Foreign Countries in Postal Union, - . . .	4 00
Single Copies, - . . . . .	.10

New subscribers can commence at any time.

Payments for THE CIRCULAR when sent by mail, should be made in a Post Office Money Order, Bank Check or Draft, or an Express Money Order or Registered Letter. All postmasters are required to register letters whenever requested to do so.

Pay money only to authorized collectors having proper credentials.

Returning your paper will not enable us to discontinue it, as we cannot find your name on our books unless your address is given.

In changing address always give the old as well as the new one. Your name cannot be found on our books unless this is done.

We will continue to send papers until there is a specific order to stop, in connection with which all arrearages must be paid; but such an order can be given at any time, to take effect at the expiration of the subscription. All such orders will be promptly acknowledged by mail.

The Courts have decided that all subscribers to Journals are responsible until arrearages are paid in full and an order to discontinue has been received by the publisher.

Member of the American Trade Press Association.

Vol. XXIX. Dec. 12, 1894. No. 20

*Every line of reading matter in THE JEWELERS' CIRCULAR, with the exception of the few brief extracts from exchanges always properly credited, is written exclusively for this journal. Each issue of THE JEWELERS' CIRCULAR is copy-righted.*

ONE of our friends took issue with us on the publishing of what he deemed a trivial and inconsequential item of news. The importance of any item of news is relative; one is considered trivial in comparison to another that is considered momentous. If it is the part of a newspaper to publish the latter, it is also the part of a newspaper to publish the former. If the one conveys a pound of information, the other conveys an ounce, or a pennyweight, or a grain of information. Even in the transfer of the watch department in a store from the south to the north side of the room may reside some significance. In the infinitude of time, even those events which we count momentous, war, the overthrow

of a state, the death of a genius, are as so many grains of sand on the shores of the ocean.

ABOUT once a year, a story of buried treasure recovered comes from Mexico. It usually arrives at the opening of the new year. The circumstances incidental to the finding are always almost uncanny in their romantic character. Last year Francisco Perez was the lucky man, Guadalajara the place where the gold and jewelry were found, and \$500,000 the value of the treasure trove. We are awaiting with hair ready to rise on end for the annual report for 1895.

**The Ownership of the Engagement Ring.** THE right of possession of the engagement ring has engaged the attention of the courts of justice of the land to a marked extent during the past two months. In New York State it has been decided that the ring belongs to the donor, the decision being essentially the same as that recently pronounced in Vermont. A young man in the latter State sued to recover a ring that he had given to a young woman who, after accepting the ring, repudiated the engagement. The judge decided that it must be returned or else that the recipient must fulfil the conditions under which it was presented. On the other hand, the English courts some time ago decided that an engagement ring is not recoverable under any circumstances. These decisions are interesting to the jeweler, inasmuch as he may find himself in the meshes of a complicated lawsuit, if he has originally sold the jewel on credit or on an instalment payment plan. "Taking one consideration with another," as Gilbert's policeman reasoned, the best of all methods in the selling of an engagement ring is to demand cash down.

**Marvelous Prices for Silver Plated Ware.** THE United States Government recently advertised for bids for a large quantity of No. 12 medium knives, triple-plated Windsor tea spoons, table spoons and medium forks, and it was announced in THE CIRCULAR last week that two jobbers in Philadelphia obtained the contracts at the following prices: No. 12 medium knives, \$2.12 per doz.; triple-plated Windsor tea spoons, \$1.77½ per doz.; triple-plated Windsor table spoons, \$3.55 per doz.; triple-plated Windsor medium forks, \$3.55 per doz.

As the No. 12 knives of the best manufacturers sell at \$3.25 net, the tea spoons list at \$7.25, and the table spoons and medium forks list at \$14.50 per dozen; and as it is reasonable to presume that the jobbers who furnish the Government the goods do not do so without a profit to themselves, it may prove interesting to know what goods are furnished, and what the manufacturer gets for them, particularly as

the largest jobbers in the country who handle many more times the quantity of goods furnished to the Government, cannot with cash in hand buy first class goods such as the Government requires, at any figure like the above prices. It certainly looks as though there is a colored gentleman in the woodpile somewhere, and it behooves Uncle Sam to keep his eyes open to see that he gets what he calls for and requires. The most extensive manufacturers of these goods in the country claim that the prices quoted above are far below that at which such goods can be made.

## Is Diamond Cutting a New Industry in America?

Since Friday the special board of inquiry appointed to inquire into alleged violations of the contract labor law in the importations of foreign diamond polishers, has been in session at Ellis Island, hearing arguments on a test case which has come before it.

A meeting was held last week at the office of Bruhl Bros. & Co., 21 Maiden Lane, New York, at which, among others these diamond cutting firms were represented: Zilber Bros., Brooklyn; Sanders & Bruhl Mfg. Co., Newark, N. J.; Arnstein Bros. & Co., Stern Bros. & Co., Herman Levy, Mendes Cutting Works, and Wallach & Schiele, New York. It was decided that the cutters of this country act together in fighting the attempt to stop the importation of foreign diamond workers. These cutters claim that diamond cutting is a practically "new" industry in this country and as such that Section 5 of the Contract Labor law permits them to import workmen under contract or otherwise. The section in question reads:

Nor shall this act be so construed as to prevent any person or persons, partnership or corporation from engaging, under contract or agreement, skilled workmen in foreign countries to perform labor in the United States in or upon any new industry not at present established in the United States, provided that skilled labor for that purpose cannot be otherwise obtained in the United States.

They therefore determined to unite in an effort to obtain a favorable ruling and placed their interests in the hands of Samuel Greenbaum, of Hays Greenbaum, to fight the matter.

The case which has come up before the board of inquiry at Ellis Island, is that of a laborer admitted to have been brought here under contract, and the board has been hearing evidence to determine whether or not the diamond cutting industry is a "new" industry within the meaning of the statute. Among the witnesses first called were Leopold Stern, of Stern Bros. & Co.; Chas. F. Wood, of C. F. Wood & Co.; Sol. Bass, of Bruhl Bros. & Co.; Henry Fera; E. Arnstein, of Arnstein Bros. & Co., and others. The hearing was continued Saturday, Monday and yesterday, no decision having been reached up to the time of the CIRCULAR'S going to press.

The labor unions, it is said, are behind the fight against the importation of cutters.

### New York Notes.

Alois Kohn & Co. have filed a judgment for \$101.35 against Deborah Singer.

H. L. Judd & Co. have entered a judgment for \$154.27 against Jno. E. Jarck.

Henry E. Oppenheimer & Co. have entered a judgment for \$395.13 against David Geismar.

E. E. Orvis, 694 Columbus Ave., has given a chattel mortgage on jewelry fixtures for \$1,100 to S. M. Buffet.

Judgments have been entered against R. Harris by Marcus Adler for \$76.61 and by Lulu Livingston for \$166.97.

Judgments against Jos. Rundbach were entered Monday by L. Tannenbaum for \$1,974.15 and Morris Kollender for \$690.33.

Judgments against Louis Levin and Joseph Rubin have been entered by M. Adler for \$207.41 and by H. M. Robertson for \$168.41.

J. N. Disselkoe has entered a judgment for \$631.78 against the Free Premium Club, being the amount due on a promissory note for \$300, with interest and costs.

Friedman & Ascheim, jobbers in watches and jewelry, formerly of 51 Maiden Lane, are now established in their new quarters in the Knapp building, 41 Maiden Lane.

Jan G. C. Cottier, the surviving partner of C. Cottier & Son, 14 Maiden Lane, pursuant to statute, is advertising that he continues the diamond importing business at that address under the old firm name.

Geo. A. Miller, assignee of Silas Stuart, formerly a retail jeweler at 2 Maiden Lane, is advertising that he will sell the stock of the assigned estate at public auction on Dec. 20, and subsequent days. The sale will be conducted at 20 East 14th St., by Jno. H. French, auctioneer.

On Dec. 1st the Self-Winding Clock Co. 26 Broadway, New York, opened a branch office in Chicago, under the management of J. W. Forsinger, 301 Columbus Memorial building, where a full line of samples will be kept on display for the convenience of the Western trade.

Benjamin Lehr, 198 Broome St., who is a manufacturing jeweler, was complainant in the Essex Market Police Court, Saturday, against Herman Michaels, whom he charged with attempted larceny. Lehr stated that he discovered Michaels in his warerooms and that he had opened the doors of his safe. Michaels was held in \$1,000 bail for examination.

Sigmund Stern, of Stern Bros. & Co., Monday denied the report published in a morning paper to the effect that while in Chicago recently he lost or had stolen diamonds of the value of \$1,000. He had, it said, become ill through worry over the loss. The report, Mr. Stern claimed, was greatly exaggerated as he had lost but three stones valued at \$175.

Mordecai S. Kaufman has discontinued his action against Property Clerk Harriot for the recovery of the diamonds which he claimed were obtained on memorandum

and pawned by a Mrs. Minnie Gomez and her husband. Mr. and Mrs. Gomez were indicted on the charge of larceny over two years ago, and the diamonds were turned over to the property clerk. Kaufman later replevied the diamonds from Harriot.

The General Term of the Superior Court Monday heard the appeal of Ga Nun & Parsons, opticians, 42d St., from a judgment obtained against them by Clara M. Price. After a sensational trial last Summer Miss Price obtained a verdict for damages for personal injuries arising from the negligence of defendants in the construction of a pair of eyeglasses. Briefs on the appeal were submitted and decision reserved.

The report of the referee on the final accounting of J. T. Scott, as assignee of Albert Janicke, was filed with the clerk of the Court of Common Pleas, Saturday. An order confirming the report directs the assignee to pay over \$465.78 pro rata to preferred creditors whose claims amount to \$1,537.03, and to pay over the remaining \$931.50 to the unpreferred creditors on claims amounting to \$4,244.90. On proof of payment of said claims the order discharges and releases from liability the assignee and the sureties on his bond.

At a meeting of the creditors of Eugene B. Schiller held last week in the office of Aaron Morris, the assignee, 235 Broadway, a proposition to settle at 20 cents payable in one note endorsed, due in five months, was rejected. Mr. Schiller was not present, but his assignee gave the following statement: Liabilities between \$8,000 and \$9,000; assets, nominally \$7,600 and actually worth \$2,000. About 40 creditors were present or represented; of these 30 creditors whose claims amounted to \$4,385 were represented by Freeman & Green, the New York attorneys of the Manufacturing Jewelers' Board of Trade, of Providence. Another meeting is to be held this week.

### Claims Against the Philadelphia Optical & Watch Co.

PHILADELPHIA, Pa., Dec. 7.—The auditor appointed by the Court to audit, settle and adjust the first account of James Work and the Guarantee Trust & Safe Deposit Co., receivers of the Philadelphia Optical & Watch Co., and to make distribution of the balance in the hands of the accountant, will meet the parties interested on Dec. 18th, at 3.30 o'clock p. m., at the office of S. M. Hyneman, 717 Drexel building, this city, when all parties interested must present and prove their claims.

### A. B. Kapp Released on \$10,000 Bail.

PROVIDENCE, R. I., Dec. 11.—Albert B. Kapp was released from jail late yesterday afternoon, bail for \$10,000 being furnished by the Merchants' National Bank, of this city, William R. Talbot, cashier, at the instance of New York and Philadelphia friends. There are 42 writs returnable to the Eighth District Court on Dec. 24th,

### Last Week's Arrivals.

The following out-of-town dealers were registered in New York during the past week: B. H. Wade, Buffalo, N. Y.; St. Stephen; F. M. Shirey, Cleveland, O.; Marlborough H.; S. S. Newton, West Winsted, Conn.; Sweeny's H.; H. M. Moses, Richmond, Va.; Stewart H.; M. Davidow, Wilkesbarre, Pa.; Imperial H.; W. F. Hammond, Boston, Mass.; Park Ave. H.; O. E. Bell, Cincinnati, O.; B'way Centl. H.; G. F. Durgin, Concord, N. H.; Holland H.; W. H. Barrows, Middletown, Gilsey H.; J. A. Forsythe, Philadelphia, Pa.; Ashland H.; E. P. Bevilard, Auburn, N. Y.; St. Denis H.; J. Kornblum, Pittsburgh, Pa.; Union Square H.; E. R. Bennett, Amherst, Mass.; Continental H.; D. W. Janowitz, Baltimore, Md.; Cosmopolitan H.; M. Eiseman, Chicago, Ill.; B'way Central H.; A. B. Ryan, Middletown, Conn.; Union Square H.; I. Kaufman, Richmond, Va.; Belvidere H.

### Holly Watch Co. Declared to be "Fraudulent."

WASHINGTON, D. C., Dec. 8.—An order was issued by the Postmaster-General late this afternoon against Mrs. A. F. Rideout, managing the East Indian Co. and the Holly Watch Co., of New York, declaring those concerns to be "fraudulent." The chief Post Office Inspector in New York city was instructed to put Mrs. Rideout under arrest.

Mrs. Rideout's plan was to sell certain kinds of "plasters," with which she inclosed to the person who sent \$1 a word riddle of which the solver was to receive a gold watch manufactured by the Holly Watch Co., which has been found upon investigation by post office inspectors to have no existence.

There are three things which make a good working combination: salable goods, a pushing salesman and an attractive ad. The Parsons & Greene Co. have apparently struck this combination. They have choice papers, they employ able salesmen, and the ad. in THE JEWELERS' CIRCULAR is attractive. Thanks to this combination their goods are now being sold by some of the leading jewelers in the land. Among them may be named: Marsh & Hoffman, Albany, N. Y.; F. W. Sim & Co., Troy, N. Y.; A. D. Norton, Gloversville, N. Y.; J. A. Smith, Saratoga, N. Y.; W. B. Wilcox, Utica, N. Y.; E. B. McClelland, Syracuse, N. Y.; H. J. Howe, Syracuse, N. Y.; J. J. Freeman Toledo, Ohio; F. F. Bonnet, Columbus, Ohio; Bunde & Upmyer, Milwaukee, Wis.; C. S. Raymond, Omaha, Neb.; Mermod & Jaccard, St. Louis, Mo.; Hess & Culberson, St. Louis, Mo.; Jaccard Watch & Jewelry Co., Kansas City, Mo.; Geo. W. Biggs & Co., Pittsburgh, Pa. It would seem wise to say to any jeweler "go thou and do likewise."

The brownies are on the top of popularity. They have been added to card cases, pocket and memorandum books,

L. TANNENBAUM & Co.,  
IMPORTERS AND CUTTERS OF

**Diamonds and Precious Stones,**

Cor. Maiden Lane & Nassau St.

NEW YORK.

25 Hatton Garden, London.

TELEPHONE, LONG DISTANCE, 1959 CORTLAND.

## Special Announcement.

Mr. L. Tannenbaum begs to notify his customers and the trade in general, that he has largely extended his facilities for cutting and polishing. Hereafter he will cut and polish not only RUBIES and SAPPHIRES, which has been done for the past 15 years with increasing and gratifying success, but

# DIAMONDS

and all other stones which undergo this process.

Modern machinery of the best and most approved pattern, and workmen of the highest class will enable Mr. Tannenbaum to offer, direct from the cutter's hands, that excellent workmanship demanded by American buyers, at

## PRICES THAT DEFY COMPETITION.

Nor will buyers of Diamonds be the only people benefited. Mr. Tannenbaum imported a five years' supply of rough Rubies and Sapphires DUTY FREE under the old tariff. These goods are now being cut and polished and it is very evident that in these particular stones he can make UNAPPROACHABLE PRICES.

New York as the future Diamond Market is not a phantasy. American cutters will be shown an assortment of rough, at prices which will perhaps cause them to believe that this has already been brought about. All arrangements have been made by the firm for enormous shipments of DIAMONDS, EMERALDS, PEARLS, SPINELS, CATSEYES, MELLÉS and all kinds of Precious Stones, although to-day the assortment offered by L. Tannenbaum & Co. ranks second to none in this country.

HIGHEST PRICE PAID for all AMERICAN PEARLS and OTHER PRECIOUS STONES.



Traveling representatives may consider these columns open for the publication of any news or items of interest regarding themselves or their confreres.

**T**HE well known chain salesman, C. H. Clark, for years with J. G. Cheever & Co., will handle J. F. Sturdy & Sons' line, the coming year.

Many travelers from the jewelry district were to be seen Friday evening, Nov.

30th at the Commercial Travelers' Club, 15 W. 31st St., New York, when the club's second "smoker" of the season was held. The usual array of "talent" and the famous "C. T." punch contributed, as on former occasions, to make the evening most enjoyable. Prof. Kay's hypnotic experiments were particularly interesting and amusing. Among others who contributed to the pleasure of the evening were W. A. Powers, mimic; Prof. Adams, sleight of hand; Mr. Mocker, Mr. Riordan, J. Morton, Jos. Bell, Baldwin and Peters, mandolin duetists, and many others.

Jos. Crawford, representative for G. B. Barrett & Co., Pittsburgh, Pa., also James Brown, for the same firm, are in and will likely remain in Pittsburgh until the first of the year.

A. B. Steele, a traveling jewelry salesman, committed suicide some days ago by jumping from the steamer *J. D. Peters*, which plies between San Francisco and Stockton. The body was recovered.

Ed. T. Powers, traveling for the Meriden Britannia Co.'s Chicago house, is laid up with threatened pneumonia at the Grand Hotel, Indianapolis. Mr. Powers was confined to his bed the past week.

W. S. Pond, traveling in the south for E. G. Webster, returned to Chicago Thursday from West Virginia, stopping at Pittsburgh and Cincinnati on his way. He reports southern trade in good shape, and no complaints in that section.

Orders were booked in Philadelphia, Pa., last week by the following: S. Blackinton, W. & S. Blackinton; J. Williams, of G. Arseny; Wm. Huger, Huger Mfg. Co.; Mr. Thompson, of Henry Glorieux; Frank Wood Carter, Sloan & Co.; C. Ray Randall, Riley, French & Heffron; Geo. B. Osborn, Wm. Smith & Co.; Wm. Wightman, R. F. Simmons & Co.; Mr. Hudson, H. F. Farrows & Co.; and A. M. Leibman, E. P. Reichhelm & Co.

Representatives seen in Indianapolis last week included: Frank Cross, Dueber Watch Case Mfg. Co.; J. T. Metcalf, R. Blackinton & Co.; E. A. Tyler, Ansonia Clock Co.; Frank W. Trewin, Keystone Watch Case Co.; Fred Philips, A. & J. Plaut; and representatives of Whiting Mfg.

Co., S. Peck, Norbert Gunzburger & Co.; Strobel & Crane, Seth Thomas Clock Co., New Haven Clock Co., I. Friedman, Odenheimer, Zimmern & Co., and Rogers, Smith & Co.

The following traveling salesmen passed through Detroit last week: J. Guntzberger, C. Cottier & Son and Martin Frank & Co.; Mr. Ishem, Kent & Stanley Co.; Lawrence H. Smith, Bippart & Co.; Mr. Crane, Strobell & Crane; J. E. Simonson, A. J. Hedges & Co.; W. F. Corey, Corey & Osmun; William T. Gough, Carter, Sloan & Co.; E. T. Badoux, Spencer Optical Mfg. Co.; C. L. Joralemon, A. Joralemon & Co.; Thomas E. Rogers, Hayes Bros.; O. C. Lane, Reed & Barton; Mr. Cook, Bergstein & Son; A. H. Atwood, Towle Mfg. Co.; A. Borgzinner, S. & A. Borgzinner; representative of A. Berger & Co.; H. J. Fink, Keller, Ettinger & Fink.

Travelers visiting the Hub the past week included: Louis Blackinton, W. & S. Blackinton; Henry Tallman, Irons & Russell; George L. Paine, E. I. Franklin & Co.; Herbert C. Barker, John W. Reddall & Co.; S. K. Knapp, Seymour-Knapp-Warren Co.; Gus Strandberg, E. L. Spencer & Co.; H. W. Dunham, Meriden Silver Plate Co.; Fred. H. Miller, Shoemaker, Pickering & Co.; John Taylor, Krementz & Co.; E. Horton, J. B. Bowden & Co.; Ed. Eckfeldt, William B. Kerr & Co.; Frank Locklin Unger Bros.; W. G. Kirtland, Howard & Cockshaw; Herman A. Friese, Lewis, Kaiser & Luthy; W. J. Carrow, Mandeville, Carrow & Crane; Charles Medbuy, F. M. Whiting & Co.; A. A. Wood, Howard Sterling Co.; H. J. Ives, Wilcox Silver Plate Co.; Berj. Posner, Wallach & Schiele; W. H. Tarlton, Wightman & Hough Co.; Fred. Clarkson, Snow & Westcott; Mr. Stein, S. & A. Borgzinner; F. L. Cam, Brooklyn Watch Case Co.; John L. Shepherd, Keystone Watch Case Co.

Hustlers for holiday trade noticed in Syracuse, N. Y., the past week included: Chas. W. Noyes, Ehrlich & Sinnock; A. D. Miller, The Pairpoint Mfg. Co.; W. F. Corey, Corey & Osmun; C. N. Perley, Alling & Co.; W. S. Campbell, Day & Clark; Wm. V. Moore, Jules Laurent & Co.; Mr. Brooks, Brooks & Pike; Wm. Seckels, Seckels & Oppenheimer; Frank W. Harmon, M. B. Bryant & Co.; P. R. Ketcham, Brooklyn Watch Case Co.; E. Horton, J. B. Bowden & Co.; N. N. Hall, for P. Hartmann; J. Goldberg; Wm. S. Eaton, Aikin, Lambert & Co.; E. H. Smith, The Holmes & Edwards Silver Co.; James A. Cheney, Ludwig Nissen & Co.; R. T. Supple, for Wm. B. Durgin; Mr. Kenrick, Reed & Barton; Mr. Cook, Bergstein & Son; E. C. Ellis, J. J. Sumner & Co.; W. R. Washburne; F. S. Sherry, Jos. Fahys & Co.; Messrs. Kingman and Richardson, G. A. Dean & Co.; Mr. Brink, Crescent Watch Case Co.; Chas. Isabel, L. Strasburger's Son & Co.; W. L. Pollack, W. L. Pollack & Co.; E. Bing, for Bloch Ainé; John A. Abel, Lewis, Kaiser & Luthy; D. L. Terrell, M. Fox & Co.

## News Gleanings.

E. Rose, Joplin, Miss., is selling out at auction.

Elias B. Berry, West Boylston, Mass., died recently.

Charles Rueff, Louisville, Ky., has given a mortgage for \$757.

J. L. Goldstein, Springville, Ia., has given a chattel mortgage for \$300.

The new store of A. J. Bailey & Bros., Ontario, Cal., is open for business.

J. R. Cameron, Easton, Pa., has greatly improved the appearance of his store.

Sidney Landers has opened a jewelry store in the Gleason block, Ballston Spa., N. Y.

Jeweler A. B. Blackman, Pittston, Pa., will occupy a store in the Miners' Savings Bank, that city.

In a fire in Cleburne, Tex., a few days ago, the bankrupt stock of J. M. Clower was damaged to the extent of \$150; covered by insurance.

G. W. Kennedy, Des Moines, Ia., is conducting an auction sale under the direction of P. J. Burroughs, the Chicago jewelers auctioneer.

Supervisor M. S. Segur, Quincy, Mich., has sold his jewelry stock to D. C. Babcock, a recent student of the horological school of Parsons & Co., La Porte, Ind.

Charles Knapp, one of the burglars implicated in the robbery of C. Vander Elsen's jewelry store, Green Bay, Wis., recently, was apprehended at Iron Mountain and arrested. Seven of the 38 watches stolen were recovered.

The locally reported consolidation of the old established jewelry store of J. E. Bixler with the store of C. W. Bixler, Easton, Pa., is untrue. Mrs. Bixler will still continue business at the old stand, conducted successfully for many years.

R. S. Patterson, Port Huron, Mich., got out of bed recently and fell downstairs cutting his eye badly. He was intent on going down to his jewelry store where he was laboring under the delusion that his goods had not been safely locked up for the night.

S. H. Seligman & Bro., New Orleans, La., on Dec. 1, dissolved partnership by mutual consent. J. M. Seligman having acquired all the assets, assumes all the liabilities and will continue the business in his own name at the old stand, corner Baronne and Gravier Sts.

Col. Kavanaugh, a barber of Olewein, Ia., has been arrested by the sheriff and taken to Boscobel, Wis., charged with complicity in the robbing of Eagan's jewelry store, at Muscoda, a short time since. He waived examination and was bound over in the sum of \$1,000. He was committed.

While Samuel Myers, jeweler, Schenectady, N. Y., was at supper in the Carley



House, Albany, N. Y., on the night of Dec. 1, burglars succeeded in forcing an entrance into his residence through a rear window and carried away about \$1,000 worth of his property, consisting of gold watches, rings, scarf pins and a seal-skin coat.

Jas. Eichel, Passaic, N. J., has given a mortgage for \$1,000.

John A. Beltzer, Ogden, Utah, have given a mortgage for \$300.

T. R. McLellan has opened a jewelry shop in West Plains, Mo.

Meinhoefer & Larosh have opened at 30 S. 7th St., Allentown, Pa., a new jewelry store.

E. W. Mays has returned to his home in Plant City, Fla., after an absence of a week in Peru, Fla.

W. H. Hartley, New Smyrna Fla., will shortly remove to a new store now being fitted up in that town.

A. P. Wilson, Harrodsburg, Ky., will move into the handsome store room on the corner of Main and Poplar Sts.

Samuel Spence, Madrid, Ia., who learned the jewelry trade with G. W. Crank, has located in business in Woodward, Ia.

Alexander Bailey, Mount Sterling, Ill., has fitted up his new store in fine shape and added a stock of furniture to his jewelry line.

W. L. Jones, Martinsburg, Va., has associated with him in partnership F. E. Smurr, who has been an employe for 8 years.

Gerome Desio, Washington, D. C., has taken possession of his new establishment, 1107 F St. He celebrated his change by public receptions on Wednesday and Thursday evenings.

Greenleaf & Crosby, Jacksonville, Fla., have contracted to supply each station of the Jacksonville, St. Augustine and Indian River Railway with a fine regulating clock, framed in walnut.

David Earle, a young colored man, was arrested Dec. 3 charged with breaking and entering J. R. Hewitt's jewelry store, at Hogan and Forsyth Sts., Jacksonville, Fla., on the previous Saturday night. When searched he had in his pockets some curiosities, such as alligator teeth, pins, etc., which he had been detected trying to sell. He was turned over to the county authorities.

**Syracuse.**

Mr. Hitchcock, of Hitchcock & Morse, left for an eastern trip Saturday morning.

A. Lesser's Sons have just put in place a large new show-case for silver, of oak, black velvet lined.

The first election of the officers of the Oneida Silverware Mfg. Co. was held Thursday afternoon and resulted as follows: S. W. More, president; T. D. Wilkin, vice-president; C. A. Stringer, secretary and treasurer.

**The Latest Patents.**

ISSUE OF DEC. 4, 1894.

**530,227. WATCHCASE-TURNING MACHINE.** CHARLES E. HENRIOD-BACHNI, Bienne, Switzerland. Filed May 29, 1893. Serial No. 475,911. (No model.) Patented in Switzerland Oct. 5, 1892, No. 5,840; in France Feb. 16, 1893, No. 227,977, and in England July 19, 1893, No. 14,008.

A machine for turning watch cases which comprises a holder in which the cases are held, a rotating chuck, and a series of cutters, means for automatically feeding the cases from the holder to the chuck, means upon the said chuck for gripping the same, means whereby the cases are automatically brought successively in front of the several cutters, and forced in contact therewith when opposite the same, and means for releasing each case immediately upon its being completed.

**530,332. THREAD-CUTTING RING.** HENRY F. GANON, Indianapolis, Ind. Filed July 23, 1894. Serial No. 518,317. (No model.)

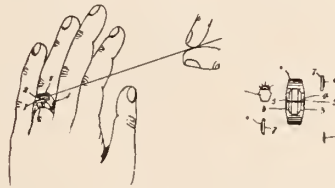

A device for cutting thread and similar material comprising a finger ring, two oppositely posed lugs mounted thereon with slots in them, and a blade adapted to fit in the slots with its edge upward and below the upper surface of the lugs.

**530,340. EMPLOYE'S TIME - RECORDER.** GEORGE W. HEENE, Brooklyn Village, Ohio, assignor to the Cleveland Time Register Company, Cleveland, Ohio. Filed Feb. 27, 1894. Serial No. 501,633. (No model.)

**530,345. CENTER-ARBOR FOR WATCHES.** WM. B. LEARNED and JAMES A. MOSHER, Boston, Mass., assignors of one-half to the E. Howard Watch and Clock Company, same place. Filed Aug. 31, 1893. Serial No. 484,436. (No model.)

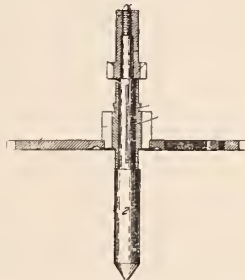

A center arbor comprising an enlarged end portion terminating in a shoulder, a centrally enlarged, slotted compressible bearing terminating in a shoulder, a reduced portion terminating in a shoulder, and a screw threaded end portion above the shoulder, combined with a center wheel and its pinion, having a hub or sleeve formed to receive said bearing and having its internal diameter slightly less than that of the largest part of the bearing, so that when said sleeve is forced upon the said compressible bearing it will compress the latter and thus cause a frictional connection between the sleeve and arbor and a cannon pinion internally recessed and threaded to receive the reduced portion and threaded portion of the arbor, said pinion bearing on the shoulder, the connection of the two pinions with the arbor being entirely independent of each other.

**530,446. WATCHMAN'S TIME RECORDER.** ABRAHAM NEWMAN, Chicago, Ill. Filed Oct. 17, 1893. Serial No. 488,442. (No model.)

DESIGNS **23,827, 23,828, 23,829.** SCARF-PINS. GEORGE F. GREENE, Providence, R. I. Filed

Oct. 31, 1894. Serial No. 527,584, 527,583, 527,582.



Term of patents 3 1/2 years.

DESIGN **23,830.** BADGE. WILLIAM H. BACH,



St. Paul, Minn. Filed April 16, 1894. Serial No. 507,772. Term of patent 7 years.

DESIGN **23,831.** BADGE. WILLIAM H. WALSH,



New York, N. Y. Filed Oct. 25, 1894. Serial No. 526,982. Term of patent 14 years.

DESIGN **23,832.** BADGE. BENJAMIN S. WHITEHEAD, Newark, N. J. Filed June 30, 1893.

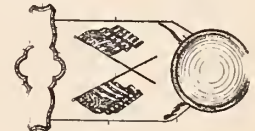

Serial No. 516,236. Term of patent 7 years.

DESIGN **23,833.** SPOON, &c. GEORGE W. SHIEBLER, Brooklyn, N. Y. Filed Sept. 22, 1894.

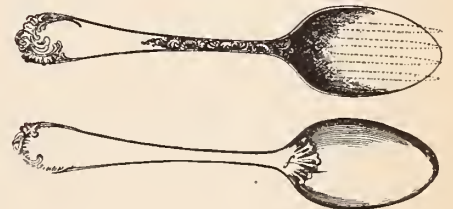

Serial No. 523,841. Term of patent 7 years.

TRADEMARK **25,568.** ALUMINUM - GOLD KNIVES, FORKS, SPOONS, FLAT AND TABLE WARE. THE WALDO FOUNDRY, Bridgeport, Conn. Filed Oct. 29, 1894.



*Essential feature.*—The representation of a griffin's head erased and the word "WALDO." Used since Sept. 1, 1894.

TRADEMARK **25,569.** CLOCKS. WM. L. GILBERT CLOCK COMPANY, Winsted, Conn., Chicago, Ill., and New York, N. Y., Filed Oct. 22, 1894.

*Essential feature.*—The compound word "WAKE-UP" Used since July 1, 1882.

# CLASSIFIED INDEX TO ADVERTISEMENTS.

All Advertisements are entitled to one insertion under proper heading. Extra insertions, \$6.00 per annum.  
Extra Headings, \$12.00 per annum.

<b>Art Pottery, Bric-a-brac, Etc.</b>	Page.	<b>Diamond Polishing Mills.</b>	Page.	<b>Sample Trunks.</b>	Page
Bing, Ferdinand & Co., 106 Grand St., N. Y. . .	42	Arthur Co., The, 86 John St., New York . . .		Crouch & Fitzgerald, 161 Broadway, N. Y. . . .	15
Bradley & Hubbard Mfg. Co., Meriden, Conn	46	<b>Fine Stationery.</b>		<b>Show Cases.</b>	
Hinrichs & Co., 29 & 31 Park Place, N. Y. . . .	47	Parsons & Greene Co., 18 Murray St., N. Y. . .	5	Smith, B. & W. B., 220 W. 29th St., N. Y. . . .	48
Healey, M. & E., Washington, D. C. . . . .	45	<b>Gold and Rolled Plate Jewelry.</b>		<b>Silver Plated Ware.</b>	
Levy, Dreyfus & Co., 9 & 11 Maiden Lane, N. Y. . . . .	17	Foster & Bailey, Providence, R. I. . . . .	3	Pairpoint Mfg. Co., New Bedford, Mass. . . . .	5
Straus, L. & Sons, 42 to 48 Warren St., N. Y. . .	41	Smith, Wm., & Co., 5-7 Maiden Lane, N. Y. . .	12	Rogers & Bro., 16 Cortlandt St., N. Y. . . . .	2
<b>Assayers &amp; Refiners.</b>		<b>Gold Jewelry.</b>		Rogers & Hamilton Co., Waterbury, Conn. . . .	19
Baker, Geo. M., Providence, R. I. . . . .	41	Aikin, Lambert & Co., 19 Maiden Lane . . . .		The Wm. Rogers Mfg. Co., Hartford, Conn. . .	15
Goldsmith Bros., 63 & 65 Washington Chicago, Ill. . . . .	34	Carter, Sloan & Co., 15 Maiden Lane, N. Y. . .	13	Webster, G. A., Chicago, Ill. . . . .	33
Le Long, L. & Bro., Newark, N. J. . . . .	48	Cross & Beguelin, 17 Maiden Lane, N. Y. . . .	7	<b>Sterling Silver Novelties.</b>	
U. S. Smelting & Refining Works, 25 John St., N. Y. . . . .	48	Hedges, A. J. & Co., 6 Maiden Lane . . . . .	4	Codding Bros. & Heilborn, North Attleboro Mass. . . . .	42
<b>Auctioneers.</b>		<b>Gold and Silver Novelties.</b>		Hagan, White & Co., 243 W. 23d St., N. Y. . . .	48
Boyle, Davis & Goodman, 63 5th Ave., N. Y., 611 Pennsylvania Ave., Washington, D. C. . . .	45	Riley, John A., & Sloan Co., Ltd., Broadway and 17th Street. . . . .	5	Holmes & Edwards Silver Co., Bridgeport, Conn . . . . .	20
Comrie, A. J., 22 John St., N. Y. . . . .	15	Waite, Thresher Co., Providence R. I. . . . .	8	Kent & Stanley Co., Providence, R. I. . . . .	10-11
French, J. H., P. O. Box 2775, N. Y. . . . .	8	<b>Horological Schools.</b>		Richardson, Enos. & Co., 23 Maiden Lane. . . .	41
H. M. Rich & Co., 21 School St., Boston, Mass. . . . .	46	Chicago Watchmakers' Institute, Chicago, Ill.	33	Webster, A. A., 30 East 14th St. . . . .	21
<b>Brownie Novelties.</b>		Parson's School for Watchmakers, Peoria, Ill.	33	<b>Sterling Silverware.</b>	
Griffith, R. L. & Son, 129 Eddy St., Provid- ence, R. I. . . . .	41	Philadelphia College of Horology, 623 Heed Building, Phila., Pa. . . . .	15	Campbell-Metcalf Silver Co., Providence, R. I.	41
<b>Badges, Medals, Etc.</b>		<b>Insurance.</b>		Fuchs, Ferd. & Bros., 808-810 Greenwich St., N. Y. . . . .	4
Stockwell, E. R., 19 John St. N. Y. . . . .	4	Fidelity & Casualty Co., 140-146 Broadway. . .	47	Towle Mfg. Co., Newburyport, Mass. . . . .	47
<b>Carborundum.</b>		<b>Jewelry, Silverware and Optical Cases.</b>		Wallace, R. & Sons Mfg. Co., 3 Park Place, 6	6
The Carborundum Co., Monongahela, Pa. . . .	45	Jackson, S. C., 180 Broadway, N. Y. . . . .	8	Wood & Hughes, 16 John St., N. Y. . . . .	45
<b>Chains.</b>		<b>Jobbers, Watches, Diamonds, Etc.</b>		<b>Thimbles.</b>	
Kent & Stanley Co., Providence, R. I. . . . .	10-11	Allen, Benj. & Co., Chicago, Ills. . . . .	15-33	Ketchum & McDougal, 198 Broadway, N. Y. . .	10
<b>Clocks, French, English and American.</b>		Aikin-Lambert Jewelry Co., 19 Maiden Lane. . .	45-46	<b>Tortoise Shell Goods.</b>	
Jacques, Chas., Clock Co., 22 Cortlandt St., N. Y. . . . .	48	Brethauer Watch and Jewelry Co., Chicago, Ill.	33	Potter, W. K., Providence, R. I. . . . .	5
<b>Cut Glass.</b>		Myers, S. F. & Co., 48 Maiden Lane, N. Y. . . .	48	<b>Tool Manufacturers and Dealers.</b>	
Clark, T. B. & Co., 860 Broadway, N. Y. . . . .	42	Sproehnle, F. M. & Co., Chicago, Ill. . . . .	35	Allen, Benj. & Co., Chicago, Ill. . . . .	15-33
<b>Diamond &amp; Precious Stone Importers.</b>		<b>Musical Boxes.</b>		Combermont, L., 45 Maiden Lane, N. Y. . . . .	48
Disselkoen, John N., 19 E. 16th St., N. Y. . .	13	Cuendet, E. L., 21 John St., N. Y. . . . .	42	American Watch Tool Co., Waltham, Mass. . .	10
Falkenau, Oppenheimer & Co., 40 Maiden	48	Jacot & Son, 39 Union Square, N. Y. . . . .	4	Moseley & Co., Elgin, Ill. . . . .	33
Friedlander, R., L. & M., Ltd. 30 Maiden Lane, N. Y. . . . .	31	<b>Ophthalmic College.</b>		Mossberg Wrench Co., Attleboro, Mass. . . . .	15
Hedges, Wm. S. & Co., 170 Broadway, N. Y. . .	12	St. Louis Ophthalmic College, St. Louis, Mo. . .	33	Oliver, W. W., Buffalo, N. Y. . . . .	33
Kahn, L. & M. & Co., 172 Broadway, N. Y. . .	48	Chicago Ophthalmic College, Chicago, Ill. . . .	33	<b>Trunks and Traveling Bags.</b>	
Kipling, E. E. 182 Broadway, N. Y. . . . .	48	<b>Optical Goods.</b>		Crouch & Fitzgerald, 161 Broadway, N. Y. . . .	15
Kipling, R. A., Hays Bldg., N. Y. . . . .	12	Geneva Optical Co., Chicago, Ills. . . . .	33	<b>Watch Manufacturers.</b>	
Lorsch, Albert & Co., 37 Maiden Lane, N. Y.	48	Queen & Co., Philadelphia, Pa. . . . .	22	Trenton Watch Co., Trenton, N. J. . . . .	17
Nissen Ludwig & Co., 18 John St. . . . .	12	Spencer Optical Mfg. Co., 15 Maiden Lane, N. Y.	39	<b>Watchmaker's Time Detector.</b>	
Randel, Baremore & Billings, 29 Maiden Lane	13	<b>Pens, Pencils, etc.,</b>		I. Imhauser, 206 Broadway. . . . .	12
Smith, Alfred H. & Co., 182 Broadway, N. Y. .	12	Aikin, Lambert & Co., 19 Maiden Lane, N. Y. . .	45-46	<b>Watch Case Repairers.</b>	
Tannenbaum, L., & Co., cor. Maiden Lane and Nassau St., N. Y. . . . .	27	LeRoy, Fairchild & Co., 3 Maiden Lane. . . . .	14	The Planchamp & Becker Co., Chicago, Ill. . . .	33
<b>Diamond Cutters.</b>		<b>Ring Makers.</b>		Henry, Peter, Cincinnati, O. . . . .	33
Fox Bros. & Co., 68 W. 4th St., Cincinnati, O.	37	Bowden, J. B. & Co., 192 Broadway, N. Y. . . .	10	<b>Watch Importers.</b>	
Oppenheimer Bros. & Veith, 35 Maiden Lane, N. Y. . . . .	44	Bryant, M. B. & Co., 10 Maiden Lane, N. Y. . .	46	Hyde's, J. E., Sons, 22 Maiden Lane, N. Y. . .	15
<b>Diamond Jewelry.</b>		Haskell, H. C., 11 John St., N. Y. . . . .	31	A. Wittnauer, 19 Maiden Lane, N. Y. . . . .	23
Jeanne, Paul, Bradley Bldg., N. Y. . . . .	42	<b>Safes.</b>		Racine, Jules, 180 Broadway, New York. . . . .	47
Leonhardt & Curran, 44½ Maiden Lane, N. Y.	10	Mosler, Bahmann & Co., 518 B'way, N. Y. . . .	8	<b>Watch Keys.</b>	
Schwab, A. G. & Bro., 61 W. 5th St., Cincin- natti, O. . . . .	36			Clark, A. N., Plainville, Conn. . . . .	48
Sauter, L. & Co., 194 Broadway. . . . .	4				

## Special Notices.

Rates 75c. per insertion for notices not exceeding 3 lines (25 words); additional words 2 cents each. If answers are to be forwarded, postage stamps must be enclosed. Two insertions, 15 per cent. off; three insertions, 20 per cent. off; four insertions or more, 25 per cent. off. Payable strictly in advance. Display cards on this page will be charged at \$2.00 per inch for first insertion, subject to same discount as above for subsequent insertions.

Under the heading of **Situations Wanted** on this page advertisements will be inserted for **One Cent a Word**. This offer refers to **Situations Wanted only**. Payable strictly in advance. If answers are to be forwarded, postage must be enclosed.

## Situations Wanted.

*Notices under this heading ONLY are charged at one cent a word, payable strictly in advance. If answer are to be forwarded, postage must be enclosed.*

**WANTED**, by a practical jeweler. Experienced foreman and designer, especially diamond work, wishes a position by Jan. 1st. Address A. B., care JEWELERS' CIRCULAR.

**EXPERIENCED TRAVELER** would like to represent an eastern manufacturer, Jan. 1st. Address Traveler, care H. B. Peters, 177 Broadway, New York.

**BOOKKEEPER**, absolutely reliable and competent to take charge of office, credits and collections, desires to make a change: for number of years in similar position in watch and diamond line; excellent references. Address Amiable, 170. Care JEWELERS' CIRCULAR.

**POSITION** desired by young man of good address and ability, where 12 years' business experience and acquaintance with New England, Middle States, and southern jewelry trade will enable him to advance; highest references. W. A. L. S., P. O. Box 1276, New York.

**SALESMAN**.—A first-class man, with unquestionable references as to ability, character, &c., direct from one of the largest houses in N. Y. city, desires an engagement to travel in New England, New York city and near-by towns. Would like line of fine gold jewelry or any manufacturer's line. H. J., JEWELERS' CIRCULAR.

**WANTED**, a position as salesman, after Jan. 1st, in a wholesale or retail jewelry business, by one who is at present engaged with one of the leading jewelry firms in this city. Best of references given. Address A. A. X., care JEWELERS' CIRCULAR.

**SITUATION** wanted by experienced jeweler and engraver. A1 reference; fine tools; east preferred. Address B. A. Martin, Jefferson, Ohio.

**POSITION** wanted by traveler for 1895. Has traveled south and west for the past 17 years. First-class reference. Address S. H., care JEWELERS' CIRCULAR.

**SITUATION WANTED**—At once by jeweler and watchmaker; eight years' experience; own tools; steady job. "J," care JEWELERS' CIRCULAR.

**SALESMAN**, several years' experience; well acquainted with jobbing and retail trade in the west, wishes a good line of gold or plate on commission in Chicago. G., care THE JEWELERS' CIRCULAR.

**CAN** you use a young man as traveler or office man who has had seven years' experience and is a worker? If so, interview M. E., care JEWELERS' CIRCULAR.

## Help Wanted.

**A TRAVELING** salesman to handle a first-class line of jewelry on commission in New York State, Pennsylvania, Ohio, or any one or two of the three, calling on the legitimate jewelry trade only in connection with his present line. Address T. 74, care JEWELERS' CIRCULAR.

**WANTED**—Letter engravers on silverware. State experience and wages expected. Address B. C., care JEWELERS' CIRCULAR.

**WANTED**, salesman, thoroughly acquainted with the large retail trade in the East and Middle States. Must be posted in the watch line. Address B. B., care JEWELERS' CIRCULAR.

**FIRST CLASS** designer for manufacturing jeweler in Newark. Address, with references, M. Z., care JEWELERS' CIRCULAR.

**WANTED**, good engraver, who can assist watchmaker when not busy engraving, for leading store in the southwest. Address, giving age and salary wanted, S. Charles, P. O., Memphis, Tenn.

## For Sale.

**FOR SALE**—Tools, fixtures and machinery of a manufacturing jeweler; can be seen in working order. Address King & Co., 355 Mulberry St., Newark, N. J.

**A RARE** opportunity for the purchase of a first-class jewelry and optical business in Asbury Park, N. J., the world-famed seaside resort; the long-established business of H. Schmidt, deceased, at No. 639 Cookman Ave., including stock, safe, fixtures, tools and materials is offered for sale; the location possesses unsurpassed advantages for a splendid investment. For full particulars address S. A. Patterson, Administrator, care JEWELERS' CIRCULAR.

## Miscellaneous.

**WATCHMAKING** thoroughly taught by an experienced mechanic. No crowded school; but a limited number taken. Charges reasonable. Actual work. For particulars, etc., address M. E. Harmstead, 709 Sansom St., Philadelphia, Pa.

**WANTED TO RENT**—Suitable accommodations with at least three windows for diamond cutting, power and good light indispensable; location in or near Maiden Lane or John St.; rent about \$30 a month. Address "Diamond Cutter," care JEWELERS' CIRCULAR.

**\$500 REWARD** will be paid for return of the 10-pointed star made by Tiffany & Co., containing 64 selected diamonds, center stone weighing 2¾ karats. The star disappeared since April 1, 1894. Possibly used as collateral security. Tiffany & Co., Union Square.

**I BUY JEWELRY STOCKS**—Manufacturers, jobbers and retailers desiring to dispose of surplus or entire stocks of diamonds, watches and jewelry, can find quick cash buyer by addressing Oscar Langer, 176 Broadway, Room 58½, or 223 E. 71st St., New York.

## To Let.

**TO LET**, at 41 Maiden Lane, a very desirable office, handsomely furnished; electric light and gas. Moderate rent. Inquire at Room 35.

## WHEEL CUTTING.

We make a specialty of Wheel Cutting, Demagnetizing and Watch Repairing for the trade. Complete plant. Send for price list.

**THE WINSLOW & PENNEY CO.**  
608 Masonic Temple, - CHICAGO.

## A FEW THINGS YOU WILL HAVE CALLS FOR.

UMBRELLA STRAPS.  
UMBRELLA CLASPS.  
HAT PLATES.

KEY RINGS.  
SNAKE RINGS.  
STONE RINGS.

## WRAZZLE DAZZLE PUZZLE RINGS.

BOOK MARKS.  
CZARINAS.

EYEGGLASS CLEANERS,  
ETC., ETC., ETC.



**HENRY C. HASKELL**, Maker, 11 John Street, N. Y.

# R., L. & M. Friedlander,

Are now located on  
ground floor of

## 30 Maiden Lane, N. Y.



We have made great reductions in the prices of Watch Glasses.

SEND FOR PARTICULARS.

IMPORTERS OF  
**DIAMONDS.**

WHOLESALE  
**JEWELERS.**

JOBBER IN  
**American Watches.**

SEND FOR OUR NEW CATALOGUE.

"THE STAR OF EMPIRE WESTWARD TAKES ITS WAY!"

# WESTERN SUPPLEMENT

## of THE JEWELERS' CIRCULAR

**Chicago Office: Room 517, Inter-Ocean Building.**

VOL. XXIX.

CHICAGO, WEDNESDAY, DEC. 12, 1894.

No. 20.

### Chicago Notes.

Henry Schmieding, 206 North Ave., has recovered from a severe attack of blood-poisoning, which required a surgical operation.

The partnership of Shourds & Kasper expires Jan. 1, necessitating the making of new partnership papers. No change in the firm is anticipated.

F. W. Hunneman, 279 Milwaukee Ave., is thinking seriously of retiring from business. Mr. Hunneman has been ill for four weeks, but is convalescing.

"The Swiss business in watches is far ahead of last year, and this is especially true of the cheaper goods," reports E. K. Boyd, representing Jules Racine & Co.

Schauweker Bros., 38 Public Square, Cleveland, have recently purchased a large stock of diamonds and will make the diamond business a prominent branch of the house.

The American Waltham Watch Co. report the net results of the year in volume of sales to be larger than the previous year, and a material increase shown in export lines.

The firm of Christoffe & Co., of Paris, have presented to the Chicago Free Kindergarten Association the sum of \$145, resulting from sales at a bazar held at the home of Mrs. Kelly, this city.

Sam. Botkowsky, 77th and Halsted Sts., has opened a branch store on Ashland Ave. and 47th St., under the firm title of Botkowsky Bros., his brother Morris joining him in this new enterprise.

Walter J. Buckley, the Seth Thomas tower clock man, returned Friday from Monmouth, Ill., where he closed a contract for a striking tower clock with five-foot illuminated dials, to be placed in the courthouse there.

"We worked till 4.15 this morning," said F. M. Sproehle, Friday, "and are boarding our entire force at the Tremont House. Increased our working force last night, but don't know what may be necessary if the rush keeps up."

Pleasures accumulated last week in the home and business life of Frank Dostal. Simultaneous with his removal into his new quarters on W. 18th St., near Center Ave., Mrs. Dostal presented her husband with a little girl.

"We are selling a larger proportion of fine goods than of the smaller, compared with previous years," says Manager Forman, of Spaulding & Co. Diamond goods and fine silver wares are prominent in the sales of this house.

In general lines the volume of business has increased for the week and 11 o'clock, p. m. finds many of the leading houses brilliantly lighted with working forces busy. The bulk of the large bills have already been purchased and now the more numerous smaller orders keep the houses bestirring late and early.

Thos. Burns and Mike Brennan, who Oct. 20, attempted to burglarize the store of Jos. P. Wathier Co., have been convicted in the Criminal Court before Judge Goggin and found guilty. The former was sentenced to the penitentiary for one year and the latter to the Reform School until he is 21 years of age.

It is rumored that the directors, or stockholders, or O. L. Rosenkranz, or others interested in the Weber Co., are offering 25 cents to settle the claims against the latter firm. Parties last week approached Chicago creditors with the inquiry as to what they would take, and the answer was, 100 cents on the dollar. Even the 25 per cent. offer, if true, is an improvement over the dividend received by creditors in the Gordon case, in Milwaukee, in which some of the same parties were interested.

The November class of the Chicago Ophthalmic College closed auspiciously with the following list of graduates: E. R. Smith, M.D., Toledo, Ia.; H. Burke, Chicago, Ill.; J. Hupp, Chicago, Ill.; Fred. Purdy, Chicago, Ill.; G. M. Stannard, Chicago, Ill.; Mary Van Patten, Chicago, Ill.; John Kuts, Chicago, Ill.; C. J. Wietz, Chicago, Ill.;

E. R. Neeper, M. D., Kahoka, Mo.; Harmon L. Smith, Watkins, N. Y.; Harry Martin, Kahoka, Mo.; Geo. J. Lewis, Chicago, Ill.; Frank Johnson, Chicago, Ill.; Abraham H. Summerfield, Chicago, Ill.; Walter M. Gates, Chicago, Ill.; Thos. J. Lambert, Chicago, Ill.; Chas. Snell, Chicago, Ill.; Geo. F. Batchelder, Milton, Fla.; J. E. Carlson, Arthur, Ill.; Ed. W. Kelly, Sullivan, Ind.; O. L. Ellis, Wausau, Wis.; C. C. W. Tousley, Ft. Atkinson, Wis. Next class begins Jan. 8th and promises to be the largest the college has ever had. Already 10 students have sent in their names.

The buyers for the past week largely included those from near by points, dealers from a distance having largely anticipated their wants during the past month: The record reads: M. Luchtemeyer, Blue Island, Ill.; Albert Miller, Dundee, Ill.; J. R. Schneider, Evanston, Ill.; J. M. Scribner, Attica, Ind.; F. Sriverts, Watertown, S. D.; S. Buysse, So. Bend, Ind.; J. W. Burkitt, Arlington Heights, Ill.; Beebe & Barber, Waverly, Ia.; J. G. Bodenschatz, Lamont, Ill.; G. S. Bander, Elburn, Ill.; L. H. Bauer, Elgin, Ill.; O. S. Clayton & Son, Aurora, Ill.; W. W. Denny, Aurora, Ill.; Mrs. E. E. Dame, Baraboo, Wis.; Egerman & Son, Aurora, Ill.; D. E. Harrington, Hebron, Ill.; Secord-Hopkins Co., Kensington; J. C. Johnson, Mt. Sterling, Ill.; C. C. Kennedy, Hinckley, Ill.; E. Keller, So. Chicago, Ill.; Lundgren & Wilson, St. Charles, Ill.; G. B. McOmber, Benton Harbor, Mich.; C. J. Peterson, St. Charles, Ill.; G. M. Rigdon, Streator, Ill.; Mrs. F. J. Reemer, South Chicago, Ill.; C. C. Reed, Lincoln, Ill.; Racine Jewelry Mfg. Co., Racine, Wis.; G. W. Teed, Webster City, Ia.; W. P. Yeoman, Waukegan, Ill.; W. E. Birkenbeuel, La Salle, Ill.; B. H. Tater, Wilnot, Wis.; J. W. Hamilton, Danville, Ill.; T. S. Arthur, Marinette, Wis.; E. G. Dalton, Bourbon, Ind.; R. H. Denney, Portland, Ind.; M. V. B. Elson, Freeport, Ill.; O. L. Rosenkranz, Milwaukee, Wis.; K. S. Buck, Waukegan, Ill.; Mr. Christophersen, Menominee, Wis.; W. E. Cooley, Brodhead, Wis.

# LOOK AT THESE PRICES!

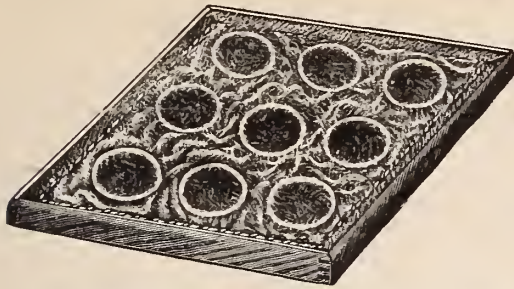

Show Case Trays with Solid Walnut Frames lined with Fine Red Silk Plush, with Old Gold Border, and made to stack one on top of the other. Size, 11 3/4 x 11 3/4.

For Gents' Watches, each . . . . . \$1.25  
For Ladies' Watches, each, . . . . . \$1.25  
For Rings, each . \$1.25. For Chains, each, . \$1.25  
For Charms, ea., \$1.25, for Card Jewelry, plain, ea., 80c.

Subject to the usual discount for cash.

**CHRISTMAS IS COMING.**  
Make your Stock Attractive and Fresh. It does not cost much and will add largely to your SALES.



## BENJ. ALLEN & Co.,

141 & 143 State St.,  
CHICAGO, ILL.

### FINE PLUSH BOXES.

WATCHES, CLOCKS,  
DIAMONDS,  
SILVERWARE  
and JEWELRY.

For Gents' Watches, per dozen, \$3.00  
For Rings, per dozen, . . . . . \$2.00  
For Six Tea Spoons, per dozen, \$9.00  
For Child's Set, per dozen, . . . \$9.00  
For Sugar Shell, per dozen . . \$9.00  
For Ladies' Watches, per dozen, \$3.00  
For Ear Drops, per dozen, . . . \$3.50  
For S x Table Spoons, per dozen, \$15.00  
For S x Coffee Spoons, per doz., \$15.00  
For Butter Knife, per dozen . . \$9.00

Subject to the usual discount for cash.

**THE PLANCHAMP & BECKER CO**  
Makers and Repairers of  
**WATCH CASES,**  
Gold and Silver Plating —  
of Watch Cases a Specialty.  
UNEXCELLED FACILITIES.

73 and 65 East Washington St., Chicago

**PARSONS & SCHOOL**  
FOR  
**WATCHMAKERS,**  
PEORIA, ILL.

Send for Circular and Terms.

**PARSONS & CO.**

EST. 1870. **DR. FETER HENRY**  
SPECIALIST IN  
Watch Case Diseases



Key Winders changed to Stem Winders  
Hunting Case changed to O.S.  
English Case changed to fit American movements.  
Can be cured at  
53  
LONGWORTH ST.  
Cincinnati, Ohio.



One of the best of the very best.

QUALITY IS THE STANDARD OF VALUE  
FOR WHICH WE COMPETE

"THE MOSELEY."

"A Bread Winner" for the watchmaker. We furnish you good lathes and chucks, while the other fellow furnishes the wind.

MOSELEY & CO., Elgin, Ill.



No. 2 Moseley Wire Chuck has length, strength, accuracy.

MORE ADVANTAGES—LESS COST.

CHICAGO  
ROCKFORD

## Watchmakers' Institute

211-20 WALNUT ST., ROCKFORD, ILL.

Write for New Terms

G. D. PARSONS, Principal

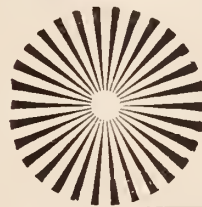

### OPTICIANS' SCHOOL.

If you want a GOOD ROOF over your head, come to our school. We want EARNEST STUDENTS, leave the rest to us, we do not want diploma hunters.

The Chicago Ophthalmic College and Hospital,

H. M. MARTIN M. D., PRESIDENT. 607 VAN BUREN ST., CHICAGO  
Being the oldest and most favorably known College of Theoretical and Applied Ophthalmic Optics in America, having more thoroughly qualified opticians in the field than all other so-called schools combined.

## G.A. WEBSTER

42 & 44 Madison St., Chicago, Ill.

**Manufacturer,**  
AND WESTERN AGENT FOR  
E. G. WEBSTER & SON, of Brooklyn, N. Y.  
A. F. TOWLE & SON CO., of Greenfield, Mass.



**GENEVA**  
**OPTICAL Co.,**  
CHICAGO.

CATALOGUES.

- PART 1—General Catalogue of Optical Goods.
- " 2—Microscopes and Accessories.
- " 3—Photographic Cameras, Stocks and Supplies.
- " 4—Thermometers, Barometers and Meteorological Instruments.

**PRESCRIPTION WORK** Made with Promptness and Accuracy.

**OCULISTS' or OPTICIANS' OUTFITS.** Trial Cases. Ophthalmoscopes. Lens Measures.

CORRESPONDENCE SOLICITED.

# THE JEWELERS' CIRCULAR

And keep informed on the latest Trade events.

—17 Jewel Dueber-Hampden Watches—  
ARE THE MOST RELIABLE WATCHES MADE.  
A FULL LINE OF DUEBER CASES AND HAMPDEN MOVEMENT.

Write for New Price List.

**Brethauer Watch and Jewelry Co.,** Special Agents,  
71 WASHINGTON ST., CHICAGO, ILLS.



## The St. Louis Ophthalmic College and Hospital

A SCHOOL OF THEORETICAL AND APPLIED OPHTHALMIC OPTICS.

1655 SOUTH JEFFERSON AVENUE,

N. W. Corner Lafayette Avenue, ST. LOUIS, MO.

For the Announcement and further information, address Ignatz Mayer, M. D., President.

### Indianapolis.

Jan. A. Allison recently became a benedict.

A. Meissen, Cicero, Ind., was in the city last week buying goods.

Will Todd, of Everson & Todd, Madison, Ind., has returned from a trip to Florida.

F. C. Smith, formerly with Lynn, Leedy & Daugherty, has gone into business for himself.

Charles W. Lauer, traveler for Baldwin, Miller & Co., was called home from southern Indiana last week on account of the serious illness of one of his children.

W. J. Davisson, Farmland, Ind., has constructed an electrical street car, six inches in length, with a dynamo on the inside and lighted with incandescent electric lights. The car whirls with great speed around a track in his show window and attracts much attention. Mr. Davidson is a jeweler with much mechanical ingenuity. He recently constructed a dynamo and built the engine and boiler with which to run it.

In an extra edition of the Indianapolis *News*, Dec. 6th under the head of "Leaders in Indianapolis Business Life," the jewelers receive their share of attention. Julius C. Walk began his trade of watchmaker and jeweler at the age of 14 years. In 1863 he took a position with W. P. Bingham, and in 1877 became a partner. Upon the death of Mr. Bingham in 1889, Mr. Walk bought out his interest and soon took his son Carl F. Walk into the firm. This firm are agents

for Patek, Philippe & Co., Vacheron & Constantine, and E. Koehn's watches. Wm. T. Marcy will very soon celebrate the 20th anniversary of his business life in Indianapolis. He is watch examiner for the Big Four and Monon railroad systems. William F. Eisele is a practical workman, bred in all the branches of the business in Heilbronn, Wurtemberg, Germany. He came to Indianapolis in 1874. In 1876 Mr. Eisele obtained a patent on an adjustable ring, which can be made to fit any sized finger without cutting. Horace A. Comstock is a young man who has built up a leading business in the city with little capital but plenty of business ability and a full knowledge of his trade. John Wimmer has for 15 years conducted a very successful optical business at 14 N. Penn St.

### Detroit.

A blaze in D'Arcy's jewelry store, Battle Creek, Mich., did \$75 worth of damage last week.

Henry Krug has removed his jewelry store from 458 Gratiot Ave. to more commodious quarters a few doors above.

Ernest Pudrith, with Eugene Deimel, last week started for a trip through the Upper Peninsula. He reports business as good from the mining country.

W. P. Sessions, formerly a jeweler of Port Huron, Mich., was sent to the Pontiac asylum for the insane a few years ago. This Summer he was allowed to go home

to his parents in Northville. He stayed three months when he again showed symptoms of insanity and was returned to the asylum.

The holiday business opened up with a rush with both the jobbers and retailers. The former are working nights for the first time in a year. The stores of the latter have assumed a holiday appearance and are thronged with customers. The following Michigan country jewelers purchased goods of the jobbers here last week: F. J. Barlow, Williamston; A. Geiger, Bay City; William Ambler, Northville; E. V. Allison, Pontiac; W. P. Losey, Metamora; John Steele, Plymouth; C. G. Draper, Plymouth; Mr. Van Alstine, Morenci; C. D. Lewis, Memphis; Mr. Merritt, of Merritt & Co., Northville; S. A. Cleveland, Utica; S. G. Bentley, Mt. Clemens; Fred Grimm, Mt. Clemens; Herman Jacobs, Sand Beach.

### Kansas City.

Among the buyers in town the past week were: D. H. Mitchell, Marshall, Mo.; and W. H. Meyer, Mo.

V. S. Cuthbert, with Otto Young & Co., Chicago, was in town last week, stopping with his brother-in-law, Harry Carswell, of Jaccard's.

The following travelers were in Kansas city, the past week: J. J. McDonald, Krouse, Boice & Co.; O. R. Ryan, Towle Mfg. Co.; J. R. Crane, Strobell & Crane; and Geo. L. Brenning.

# Now IS THE TIME . . .

To look over your old style and unsalable jewelry, old plated jewelry, filings, sweeps, etc  
You want to put your stock in good shape for the holidays. The question is:

"Where shall I send my old gold and silver?"

Remember, that we pay 4c. per kt. for Gold and Highest Market

## Prices for Old Silver.

There is a well known maxim that "Experience makes perfect." To accurately test and value a lot of old gold, etc., the requisite experience is absolutely necessary. Being the largest buyers of old gold and silver in the country, and having the exclusive patronage of the majority of the jewelers in the United States and Canada, we can guarantee to the trade accuracy in valuation and

**PROMPT AND HONEST RETURNS.**



## OUR PLAN

Immediately upon receipt of shipment we will remit by cash or draft (as desired). If our offer should not prove satisfactory, we will return consignment in exactly same condition as received, and pay all charges. By this arrangement you are absolutely safe, as it is no sale unless our offer should prove satisfactory, and you run no more chances than if you were disposing of same right over your counter.

## GOLDSMITH BROS.,

Mention the Jewelers' Circular.

Gold, Silver and Platinum Refiners and Assayers,

**FREE**—Send for our LITTLE BOOK giving pointers on preparing acids, testing and buying gold, etc., mailed free on application.

63 & 65 Washington St., Chicgao, Ill.

The Jaccard Watch and Jewelry Co. report holiday trade to be better now than for some years back. They have hired a large force of extra help.

F. G. Altman has decided to close out his retail jewelry store, at 1117 Main St., and engage in the dental supply business, having now an interest in one of the dental colleges here.

The Sigma Nu Fraternity have engaged the Jaccard Watch and Jewelry Co. as their official jewelers for this section, and this company will make all of their emblems and prizes for the future.

Mr. Hoefler, of Woodstock, Barger & Hoefler, has just returned from an extended trip through Nebraska. Although the trip was partly for pleasure, he managed to secure several good orders for his firm.

### Minneapolis and St. Paul.

W. C. Kayser, Marshall, Minn., closed his auction sale Dec. 1.

B. W. Annin, watchmaker until recently located in the Guaranty Loan Building, has removed to 1000 Nicollet Ave., ground floor.

S. H. Clausin, of S. H. Clausin & Co., of Minneapolis, left last week for California to spend the Winter, Mrs. Clausin accompanying him.

Emil Haenoine, jeweler, Kaukauna, Wis., assigned Dec. 5. His liabilities are quite heavy. Assets are not known. F. F. Becker is assignee.

The Harry F. Legg Jewelry Co., Minneapolis, are advertising a closing out sale, which commenced Dec. 3d, and is to continue to Jan. 1st. Mr. Legg announces that he will retire from the jewelry business.

Eastern jobbers and manufacturers having representatives in the Twin Cities the past week were: J. I. Roe, New York, by Mark Franklin; Amberg & Co., Cincinnati, by Sam Goldberg; A. Goldsmith & Son, New York, by S. A. Goldsmith.

Out-of-town jewelers visiting the Twin Cities the past week were: Albert Aslessen, Sacred Heart, Minn.; B. C. Bennett, Pine Island, Minn.; J. E. Olson, Glenwood, Wis.; E. H. Sawyer, Faribault, Minn.; A. E. Madsen, North Branch, Minn.; Karl Rosell, Harris, Minn.; C. A. Schneider, Faribault, Minn.; Mr. Nelson, Belgrade, Minn.

### St. Louis.

The marriage of Charles Buttner, of the E. H. Kortkamp Jewelry Co., to Miss Hattie Piesch, of South St. Louis, has been indefinitely postponed owing to the continued illness of the bride-elect.

The case against F. M. Rodgers, charged with the larceny of diamond rings valued at \$2,000, from Mermod & Jaccard Jewelry Co., has been dismissed by the grand jury. It is understood that Goodman King, manager for Mermod & Jaccard Jewelry Co.,

refused to prosecute, as Rodgers' friends had made restitution to the company.

Chas. Frechman conducts a small jewelry establishment at 2304 Franklin Ave. About 7 o'clock on the night of Dec. 1 a thief smashed the front show window and stole four gold watches. The noise attracted attention, the bold burglar was pursued and one shot fired at him as he ran, but he escaped.

The Retail Jewelers' Association of Missouri have framed a bill to regulate the sale of "snide" jewelry and night auctions, as well as to limit the number of auctioneers. Night auctioning of jewelry is to be especially condemned in the bill. In March the president and a number of other members of the association will attend the sessions of the Legislature to see that the bill receives recognition.

### Cincinnati.

J. D. Williams, Blanchester, O., was in Cincinnati last week buying goods.

Jos. Homan is in New York superintending the opening of his firm's new sales-rooms.

The Frankenstein Co. had an auction sale last week. They will renew it this week.

Jos. Goesling, of Jos. Noterman & Co., will remain in Colorado until Spring, when he expects to return a healthy man.

A smooth pennyweighter relieved Os-kamp, Nolting & Co., of a \$100 watch last week, and escaped before the theft was discovered. He is still at large.

Jonas, Dorst & Co. have called in their travelers as they need the stock they carry to supply the orders coming in to the house. The factory is running steadily.

O. E. Bell & Co.'s proposition to give an exclusive sale of their immense bargains to one jeweler in each town is meeting with great success, everybody wanting to be that particular jeweler.

The assignment of Mrs. M. Hammelrath, 447 Vine St., last week caught a few Cincinnati jobbers. There was a preference in chattel mortgages for \$2,500 made to relatives on borrowed money. The assets are placed at \$10,000 including some real estate.

Thursday night the Cincinnati Parcel & Express Co.'s headquarters on Main St., were burglarized and considerable booty taken. The thieves broke open every package containing jewelry or silverware. It has not been ascertained how much plunder was secured.

About \$600 worth of jewelry was stolen the night of Dec. 1 from the show cases of Norman & Brickey, Alvarado, Tex., shortly before closing time. Three strangers, two men and one woman, were overhauled at the depot and held until next morning, as suspects. They were released, as nothing but the fact that they were strangers in Alvarado could be charged against them.



Our Salesman

# Watch

the results of

Our  
Salesman

640 Page Catalogue, 1895,

# Open

On your Show Case.

That will prove his value to you. He does not draw any salary but will double your sales. Open on your show case, as inquisitive people can't help but buy. Bottom prices and special drives are his strongest arguments why you should buy of him.

Send for our 640 Page Illustrated Catalogue if you haven't received it. It's a money maker for you.

OUR NAME DON'T APPEAR IN IT.

## F. M. Sproehne & Co.

103 STATE ST., CHICAGO,

Wholesale Jewelers.

YOU'LL SAVE MONEY

by ordering your Holiday Stock from it.

### Pacific Coast Notes.

A new jewelry store will soon be started in Mayfield, Cal.

R. McReany, formerly of Lakeport, Cal., will open a jewelry store in Martinez, Cal.

Jeweler Heerdt, Salinas City, Cal., has moved into a new store and is enlarging his stock.

An auction is in progress at the store of W.B. Miller, Sacramento, Cal. F.T. Keeler is the auctioneer.

### Rockford.

E. Lane, the Genoa jeweler, bought goods here last week.

E. Kizer, of this city, opens his new jewelry store in Pecatonica this week.

D. F. Sullivan opened his new store Monday last and it struck the public fancy straightway. It is located at the corner of State and Wyman Sts., in the center of the city, and it is said there is no prettier jewelry store in the State outside of Chicago.

### The Self-Winding Clock Co.'s System in Chicago.

CHICAGO, Ill., Dec. 8.—Kennedy Duff Dec. 1 assumed his duties as assistant to J. W. Forsinger, manager of the Chicago office of the Self-Winding Clock Co. Mr. Duff will represent J. W. Forsinger in the placing of the firm's self-winding synchronized clocks.

Prominent Chicago buildings equipped with the synchronized time plants of this company include:

Chicago *Daily News*, Board of Trade, Mona Inock building, Chamber of Commerce, Masonic Temple, Woman's Temple, Grand Pacific Hotel, First National Bank, Chicago *Times*, Manhattan building, Owings building, Tribune building, Siegel, Cooper & Co., Medinah Temple, Ellsworth building, Old Stock Exchange, Counselman building, Auditorium, Ogden building, Columbus Memorial building, Inter-Ocean building, Home Insurance building, Tremont House, New York Biscuit Co., Swift & Co., Exchange, (Stock Yards), Rialto building, City Hall, Rookery, Chicago *Herald*, Chicago Stock Exchange, Kingsley Restaurant, Tacoma building, Illinois Central Station, Chicago *Evening Post*, Chicago Beach Hotel, Chicago *Mail*, New York *Life*, Oxford building, Unity build-

ing, Chicago Club, Chicago *Despatch*, Rand, McNally & Co., Central Music Hall, Royal Insurance building, Montauk building, Evening *Journal*, Title & Trust building, Imperial building, Link Belt Machinery Co., New Stock Exchange.

### The Jewelers' Circular Elects Officers.

CHICAGO, Ill., Dec. 8.—The election of officers for Jewelers' Council, No. 316, National Union, Dec. 1, resulted as follows, president W. J. Meyer and secretary Otto Stumpf declining re-election:

President, H. E. Farquharson; vice-president, A. H. D. Wedeking; speaker, F. McGredy; ex-president, W. J. Meyer; secretary, C. E. Hodge; financial secretary, C. A. Barnes; treasurer, Harry Sax; chaplain, J. Bachner; usher, B. Volk; sergeant, S. W. Overend; doorkeeper, E. G. Smith; trustees, J. T. Campbell, F. C. Ralston and J. W. Atwell.

Kaylor Brothers, Pekin, Ill., have opened a new jewelry store on Court St.

Atla, the ten-months-old son of Mr. and Mrs. Charles Jenkins, Richmond, Ind., died Dec. 4, of congestion of the brain.

Sig. Friedman, Logansport, Ind., will leave for Petersburg, Ill., about Jan. 1st, where he enters the partnership of Heinsheimer Bros., jewelers.

The Gundlach Optical Co., to manufacture optical goods and instruments, in Rochester, N. Y., have incorporated. Capital, \$24,000. Directors are: Rhoda E. Turner, Sarah Zellwegger and Catharine Reich, of Rochester.

Carrie Smith, who was arrested recently on a warrant sworn out by Brunner Bros., Cleveland, O., charging her with having stolen jewelry from their store, sued the firm for \$15,000 Wednesday, for false imprisonment.

Kreider & Leiff, Denver, Col., claim that they have been fraudulently encumbered out of a stock of manufacturing jewelers' tools worth \$4,000. They testified that James F. Cooper, the defendant, told them that the outfit was free from all incumbrance, and that, with this understanding, they put up their notes for the purchase price of the tools, which were in the store at 2100 Arapahoe St. It was afterwards discovered that H. C. Mentzer had a chattel mortgage on the same property for \$1,000.

### Preliminaries of the Banquet of the Chicago Jewelers' Association.

CHICAGO, Ill., Dec. 10.—Pleasant memories of Feb. 8, 1893, were recalled Tuesday week, by the action of the Chicago Jewelers' Association in deciding to renew its annual banquet. On the above date occurred the last of these social gatherings. Last February no banquet was held, the members, as individuals contributing generously to charitable purposes in aid of the unemployed of the city.

At the regular monthly meeting of the association, Dec. 4th, the subject was brought before the body, with the result that a banquet will be held the latter part of January or early in February. President Grove Sackett was authorized to appoint a committee to arrange the details. Judging from past standards the affair will be a leading social event of the season among the commercial bodies of this metropolis. No other action of importance came before the meeting, the members one and all showing an anxiety to return to business affairs, which now require their full attention.

Thursday President Sackett appointed the following committee to arrange the details of the banquet: A. L. Sercomb, chairman; H. F. Hahn, J. F. Talbot, J. A. Todd, J. P. Byrne, secretary, and president Grove Sackett, ex-officio. Friday the committee met in the rooms of the association and for an hour and a half discussed the subject on general lines and mapped out work, such as securing hall, etc. Details were not advanced sufficiently to decide on a date for the banquet further than that it be held the last week in January.

"Invitations will be sent to the principal officers in National, State and City governments, and to the presidents of the principal commercial bodies," said Secretary Byrne, of the committee, after the meeting, "and every effort will be put forth to make it the finest banquet ever held by the Chicago Jewelers' Association."

E. H. Fisher's jewelry store, Lorain, O., was entered, Wednesday night last, by burglars, who took about \$600 worth of jewelry and silverware. C. E. Daniels slept over the store with a burglar alarm attached to every window. The alarm rung, but seeing nothing suspicious, Daniels turned it off and went to bed again.

# DIAMONDS

Loose and Mounted, in Endless Variety, at Unequalled Prices.

61 West Fifth St., A. G. SCHWAB & BRO., Cincinnati, Ohio.

Sole Agents for the Celebrated **PASHA DIAMOND...**

White Stone Gold Jewelry.





## PROMINENT FIRMS OF THE WEST.

F. M. SPROEHNLE & CO.

LOOKING back on the few years intervening since 1883, and the present, F. M. Sproehnle & Co., Chicago, should find cause for congratulation in the truly remarkable growth of their wholesale jewelry establishment. One is forced to the conclusion that such unexampled increase is not the result of any ordinary business management, but is due rather to excep-

tion of the Columbus Memorial building at the southeast corner of State and Washington Sts., and the jewelry interest became firmly centered on State St.

With a constant growth for several years, the brothers felt assured of a strength sufficient to compete with the then larger houses, and on the completion of the Columbus Memorial building they took a long



F. M. SPROEHNLE.



A. W. SPROEHNLE.

tional ability and a breadth of trade insight that few possess. The firm commenced business in a little 2x4 room on the 6th floor at Randolph and Dearborn Sts. in 1883 as Bryant, Sproehnle & Co. and memory could easily have served as bookkeeper. They continued in a small way for four years, when Albert W. Sproehnle purchased Mr. Bryant's interest, the latter retiring.

In 1887 the firm, consisting of F. M. Sproehnle and Albert W. Sproehnle, brothers, became more pretentious by the removal to second floor quarters at 110-112 Wabash Ave. Here the possibilities for larger growth became recognized and with increased business the firm in 1892 secured a fine location at 195-197 Wabash Ave., the trend of business having turned toward Van Buren St. Here they occupied spacious quarters—2,200 square feet on the second floor—and were directly in line with the southward advance of the jobbing interests. This advance was checked by the comple-

stride to the front by securing an entire half of the third floor, the most desirable floor in this commercial palace. May 1, 1893, found them in their new quarters and present location, with an assortment of general jewelry lines which it was a pleasure to them to present for the inspection of their greatly enlarged list of customers. The growth of recent years was here largely augmented and to-day the firm look back without a regret over the business opportunities which they have so signally mastered.

Frank M. Sproehnle, the senior member of the house, was born Feb. 28, 1859, on Van Buren St., near the present Board of Trade. He attended the public schools till he was 14 years of age. At 14 he was given choice between a business education and a preparatory collegiate course and he selected mercantile life, engaging as errand boy for B. F. Norris, Alister & Co., at \$4 per week. Ten years later he had by suc-

cessive promotions secured the highest position the house had to offer, that of credit manager. In 1883 he engaged in business on his own account with the brilliant success above noted. Jan. 11, 1893, Mr. Sproehnle married Miss May Reeves Caliger, of this city, and a boy of 11 months blesses the union.

Albert W. Sproehnle, the junior member, is also a Chicago boy, dating from Oct. 31, 1862. He also studied in the public schools till 14, when he entered the employ of a stove manufacturer and was advanced by promotion until his eyesight failed and he was obliged to give up office work. He then conducted a grocery business for four years, later going to Notre Dame University, where he studied law. On the completion of his law course he was induced to give up the profession and take Mr. Bryant's interest as his brother's partner. The result has been exceedingly happy.

From the time the brothers engaged in business the house doubled its business each year for three years and has had an uninterrupted and healthy increase in business ever since. The past year the firm have increased the working force 25 per cent to keep pace with the growth of their business. They employ no travelers, but publish "The Salesman," a catalogue work of unusual excellence, which laid open upon the counter of a retail store will promote sales and give the retailer the advantage of complete wholesale lines at prices that make them profitable to the retail dealer.

### San Francisco.

A. Hirshman, Sutter St., is conducting a special sale to reduce stock.

B. Hoisholt, Oakdale, and N. H. Wilson, Merced, were in town recently.

F. A. Jeanne, representative of Alfred H. Smith & Co., New York, has been in town.

E. C. Marhave, of Phelps & Miller, has returned from the south. He had a successful trip.

G. E. Powell, of the California Jewelry Co., has returned from the north and reports a fair trip.

A. de Neuf, Virginia City, Nev., and Peter Engle, Marysville, Cal., were among the latest arrivals from the interior.

DIAMOND CUTTERS and POLISHERS looking for desirable and permanent positions should apply direct to

**FOX BROS. & CO.,**

68 and 70 West 4th Street,

CINCINNATI, OHIO.

## ADVERTISING HINTS FOR RETAIL JEWELERS.

BY CHARLES AUSTIN BATES.

The Editor of THE JEWELERS' CIRCULAR has asked me to contribute a series of articles on retail jewelry advertising.

It is my desire to make these articles as useful as possible and to that end, an invitation is extended to retailers to send to me any of their advertisements which they would like to have criticised. It may be that there are some questions which they will care to ask and that I can answer.

Each week I will give several examples of advertising, which will illustrate my ideas on the subject. I do not present these advertisements with the claim that they are perfect, but only with the hope that they will contain some useful suggestion, and that some dealer at least will find that by making slight changes in them, as local conditions require, they will be able to make use of them, and so relieve themselves of one detail of their business

### PART VIII.

**T**WO more weeks of rush and big business. Two more weeks of big advertising for the jeweler who means to get his share of the holiday trade. The worst mistake he can make is not to use enough advertising space. To be sure, he will do a good business anyway, whether he advertises or not, but if the conditions are ripe for a good business, why not give a little extra effort and have a great, big, roaring trade?

People are walking around the streets now, with money sticking out of their pockets. They cannot find places enough to spend it. The man who reaches out with his advertisements and pulls them into his store, is the one who is going to get the money. His less aggressive brethren will get what he leaves. Some of them may get left entirely.

Do not be afraid of using plenty of space and do not be afraid to advertise special articles. People are lying awake nights trying to think what they are going to give to other people, and if you can give them a timely hint, you will gain their Christmas trade and their undying gratitude. Make the advertisements bristle with suggestions for Christmas presents. Put in the prices. The more items and the more prices, the better the ad. There a lot of people who have made up their minds that they are going to spend two dollars for a present for Mamie, and they are looking for most anything that will fit that two dollars. And there are others who have decided on fifty dollar presents, and they are looking for something to fit their fifty dollars.

Do not look quite so closely after the amount of space that the ad is going to take now as you do in quieter times. Do not think so much of what the advertisement is going to cost, and try to fill the store so full that you could not get anybody else in. Profit lies in the increased business. After there is business enough to pay the running expenses, all the difference between cost and selling price is clear profit. The way to make this profit big is to advertise largely. Everybody else is using big space, and if you do not, your advertisement will be lost.

It is a good deal better to pay twenty-five dollars for an advertisement that will be seen, than to pay two dollars and a half for one that will not be seen,

Providence jewelers are wide-awake, as these two advertisements show. The style

## Quaint Delf Ware!

The pride of Holland in the seventeenth century is now eagerly sought by admirers of Artistic China.

We have just received some choice examples in Tiles and Placques, decorated in the blue, by Bisschop, Verier, Apol, Du Chattel and other noted artists.

Each piece faithfully portrays the rural scene with its characteristic dike and windmill.

Beautiful specimens of Imperial Sèvres, recently imported and now ready for inspection.

TILDEN-THURBER CO.

**ADVICE** to those wearing Diamonds!

It pays **TO** see if they are secure.

**OWNERS** of Diamonds should attend to them.

An ounce **OF** prevention is worth a pound of cure.

**DIAMONDS**

Examined Free of Charge  
to Secure Against Loss.

**HENRY C. WHITTIER & SON,**  
327 Westminster Street, Providence.

of composition used in the one of Tilden-Thurber Co. is very much better than that use of some strong word or line which would show at a glance what the advertise-

of H. C. Whittier & Son. The trouble with the Whittier ad. is that it is cut up too much. If they had made a good strong headline of the words "Advice to owners of diamonds," cutting it up into two or three lines, and had then set the other matter in a small, plain paragraph in the center of their space, they would have had a more effective and a more readable ad.

\*\*

The style of this advertisement from New Haven is very good. It takes the tone

## CONFIDENCE

In a diamond merchant is a more desirable qualification on the part of intending purchasers than reliance on their own limited knowledge of the relative values and merits of Precious Stones.

To become expert in Gems, one requires not only a natural genius for the profession, but many years of close application and constant association.

Our established reputation as Diamond merchants is a guarantee that misrepresentation is never resorted to in order to effect a sale, and we cordially invite the public to call on us and look through our magnificent array of Diamonds, selected with care, which we offer at least 15 per cent. less than any other house in New Haven.

### SILVERTHAU'S

Jewelry Store, 790 Chapel Street,  
the Diamond Experts.

Headquarters for Wedding Gifts.  
Select your Christmas Gifts now  
and save money.

New Haven, Conn.

which I think it is well for jewelers to take. The idea in the first paragraph is one that can be used frequently and with good effect. There are very few dealers who are not willing to fully guarantee the accuracy of the representation of their goods. This is a good thing to say in advertisements.

\*\*

I am not an advocate of the use of large black type in advertising, particularly in jewelry advertising, but I think the ad. on next page would have been improved by the

ment was about. With this criticism passed, I think the advertisement is a very good one. It advertises the whole stock of the store, and at the same time tells of special bargains in a plain and convincing way.

really an item published by the paper and not paid for by the advertiser.

When you are writing reading notices, carry the thing straight through on one line. Don't start out by trying to make it sound like a genuine reader and then spoil the

We want to call your attention to a few very interesting and economic facts, facts that you and your friends will appreciate. We are offering

- A 14k. Gold Filled 20-Year Case, Elgin Movement, for \$12.50.
- A 10k. Gold Filled Case, with an American Movement, \$8.00.
- A Rolled Plate Case, with an American Movement, for \$5.00.

These three specialties are merely indicators. We can match them on prices in any line of Jewelry, Clocks, Silverware, etc. F. H. Gillette, 9 Douglas Av.

It is in the use of reading notices that advertisers are most likely to make mistakes. It is the hardest sort of advertising to do in a proper and effective way. This one from New Britain, Conn., shows how

HE—"That ring, you know, is the emblem of eternity."  
 SHE—"Yes; and the diamond on top is heavenly!"  
 HE—"But the ring that comes later will have no diamond."  
 SHE—"N-o. I suppose the heavenly part will be over by that time."  
 Just the same, they will get them, and the best place in town is at Wood's Jewelry Store.

it should not be done. The idea is all right and the conversational style is good. The end is not. The conversation should have been kept up clear to the end, and the advertising matter brought in in the natural way just as if the reading notice were

effect of it by marking it plainly and badly as an advertisement in the last two or three lines. Reading notices can be made very effective, but writing them properly is an art which should be studied very carefully, before they are indulged in to any great extent. It is not necessary in a reading notice to make the name and business very prominent. A casual mention is all that is needed, and the more naturally this mention can be brought in, the better the advertising will be.

Chas. T. Ridgeway, Nashua, N. H., the venerable maker of silver spectacle frames in the days when hand-made goods were the only products in this line known to the trade, is the subject of a biography with portrait in the Boston *Globe* of Nov. 27. Mr. Ridgeway is in his 80th year and still in active business life.

**Jewelry Notes From Paris.**

THE POPULARITY OF THE TURQUOISE—IMITATING ENGRAVED TURQUOISE WITH ENAMEL—ORIGINAL BROOCHES.

PARIS, France, Nov. 30. —Turquoises are becoming more and more fashionable. The delicate and tender color of this pretty gem produces a quiet and refined effect when it is associated with brilliants or pearls with due regard to the size of the article it adorns. The success of the milky blue stone has urged some jewelers to imitate it with an enamel which, being inlaid with gold *motifs* slightly sunk in the ground, produces the effect of engraved turquoises. These *motifs* are delicately drawn, as if with a very fine graver, whose point was dipped in a gold mixture prepared to adhere to the substance engraved.

Some of these simile turquoises are flat or slightly hollow; some are olive, pear or heart shaped. A great many bear a tender or grave Arabic motto. These are framed with fine arabesques in gold adorned with pearls or brilliants. I have noticed, in this line, in several jewelry stores in the Rue de la Paix, a great variety of brooches, bracelets, studs, earrings, hat or fichu pins, umbrella tops, bonbonnières, etc.

An original brooch consists of a large and well faceted emerald from which start pretty diamond feathers gracefully curled, radiating closely and symmetrically all round the handsome green stone. Another brooch shows a big diamond which is the center of a trophy consisting of little daggers the hilts of which are formed alternately of rubies and topazes, the blades being gatherings of tiny brilliants, and the guards in gold being curled down at each end. These daggers radiate in a fanlike manner. Underneath the diamond two other daggers cross each other; a drop shaped pearl forming a pendant hangs at the point of junction. JASEUR.

C. F. Reitling, Carlisle, Pa., is holding an auction sale.



Just Received Our Fall Importation.

**ONE OF THE 400, AND VERY SWELL INDEED.**

**THE PERFECT FIT OF OUR No. 918 GOLD EYE GLASS, SWELL END EYE WIRE.**

Our Ambition to Make a FAULTLESS GOLD SPEC. and Eye Glass has been realized, and is appreciated. Strength and Beauty Joined Together WITHOUT SOLDER. You "see that hump" no longer. It's gone, and in its place, at ends and bridge, you find that GRACEFUL SWELL, as shown in cut. *This is the Modern and Perfect Frame the public are asking for, made in all weights, sizes, shapes and qualities.*

WE MAKE ALL KINDS OF OPTICAL SPECIALTIES, AND TEACH HOW TO GET BEST RETURNS IN HANDLING THEM.

THE AUDEMAYR OPERA GLASSES,  
 SPENCER OPTICAL MFG. CO.,

The Best Made for the Least Money. Also Cheaper Grades. The Greatest Variety of Styles. Great Reductions to Correspond with New Tariff and Other Causes. SEND FOR NEW SUPPLEMENT.

15 MAIDEN LANE, NEW YORK.

CALL OR WRITE. IT WILL DO YOU GOOD!



## The Treatment of Silver in Melting, &c.

(Continued from page 48, Dec. 5, 1894.)

THE ingot mould should be clean and smooth inside, slightly greased, and dusted over with fine vegetable charcoal; this latter substance prevents the metal from adhering to the sides of the mould. It is, perhaps, almost unnecessary to state that the ingot mould requires heating to a certain temperature before the melted metal is poured in, otherwise serious spouting takes place, resulting in a great loss of metal. On the other hand, the operator should be careful not to overheat it, as the same evil consequences may result.

The bar of metal upon cooling should be weighed, and the difference—as most meltings show a little—noted. This is *loss*, but it will be very little, if the foregoing instructions have been strictly adhered to from the beginning of the operation. With the charcoal flux, we have referred to, very nice and clean bars of metal can be produced. This flux is always floating upon the surface of the mixture, and, with a little dexterity in the pouring, it can be prevented from coming out of the crucible with the metal; its proper place is at the end of the pouring. When tin is employed, either in alloys or solders, its treatment is similar to that described for zinc; such alloys should not be kept too long in the furnace after they have become fused, as they rapidly oxidize, especially if brought in contact with the air.

The waste in silver and, in fact, of all alloys, is entirely dependent on the duration of the time of fusion. If it is prolonged after the addition of the fusible metals, the loss is greater in every case than when once melted. The metals should be subjected to the heat of the furnace for the shortest possible period. The alloys of silver with zinc would lose more than the alloys of silver with tin, because zinc rapidly volatilizes when heated above the temperature of its fusion, and this is especially the case when it enters into combination with silver and copper in their fused state; its vapors can be seen to rise and burn in the air, producing light and white flaky fumes, and chemically speaking, forming the protoxide of zinc. With care and manipulative skill during the process of fusion, the proportion of waste can be reduced to a minimum; and when this is exactly ascertained an allowance can be made in the preparation of the mixture for the crucible. From the above remarks it will be apparent that when both tin and zinc form component parts of a mixture, either to be used as an alloy or as a solder, the tin should be added to the other metals and well stirred, so as to obtain an intimate mixture before the zinc is added.

Scrap silver should be carefully sorted before undergoing the process of remelting, and, if possible, all foreign substances removed. It may, if preferred to work it in that way, be melted into a separate bar, or

otherwise used as an addition to a new mixture. When, however, it is separately melted, a flux, such as carbonate of soda, may be employed on account of its cheapness, in small proportions to the charcoal flux already alluded to. In brittle and troublesome alloys we have found charcoal and a small quantity of borax extremely effective. Saltpeter is a very useful flux for dissolving impurities, but in some alloys its presence is injurious. Sandiner will remove iron or steel from the mixture. Corrosive sublimate destroys lead and tin. We have found the sub-carbonate of potash one of the best fluxes for silver, when melters have not been quite so straight as they should be in the working of the metal; it is used in melting the difficult alloy of 18 karat gold, and is considered a secret not generally known to the trade. Salammoniac is an excellent flux for producing clean and bright ingots and tough alloys. We invariably use it with all our alloys, mixed in small quantities with charcoal, and prefer it to all others.

Lemel, that is the filings and turnings produced during the process of manufacture, should have quite a separate method of treatment. It is best prepared for the crucible by passing it through a fine sieve, afterwards thoroughly burning it in an iron ladle, and then intimately mixing it with a fine flux of the following nature and proportions: Silver dust, 24 parts; carbonate of soda, 4 parts; common salt, 2 parts, sal enixum, 1 part—31 parts.

The sal enixum prevents the rising of the mixture in the crucible, which should be shaped like a keg: wide in the belly, with top and bottom drawn in, which keeps it from overflowing; it also possesses a refining capacity the same as saltpetre, and is much cheaper. The burning of the lemel has a great tendency to destroy all organic matter that would be likely to cause the mixture to overflow during the period of fusion; but if such a thing should be at all likely to take place, the addition of a little dried common salt would remedy the evil, a small quantity of which ought always to be kept on hand for the purpose. The common carbonate of soda is also a cheap and useful flux to the silversmith. Five-sixths of the above flux should be well mixed with the stated proportion of lemel, then placed in the pot, and the one-sixth remaining placed upon the top of the mixture, when it may at once be transferred to the furnace. Great heat is required in this operation, and it also requires careful supervision to prevent, if possible, waste of material. When the mixture has become perfectly liquid, the heat of the furnace should not be allowed to decrease, but continued for half an hour longer, and if the use of it be not further required, the fire may then be allowed to gradually die out. The mixture will require repeated stirring during the period of fusion, in order to dissolve such portions as might otherwise not come immediately under the action of the flux. When the operation of fusion has been completed, the

crucible is withdrawn and allowed to cool, the solidification of the metal is then perfect, and it may be recovered by breaking the pot at the base, when it will fall out in a lump corresponding with the shape of the crucible. The lump of metal should then be carefully weighed, the loss ascertained, which always varies in proportion to the amount of organic matter contained therein; it may then be sold to the refiner.

In this process it will be observed that the crucible is broken every time a fusion takes place, consequently some little expense is incurred in providing crucibles for that purpose, to obviate which the following plan may be economically and successfully employed, and especially when the metal is sold to the refiner by assay the method about to be described will be found most advantageous, for it should be borne in mind that the lump of metal from the previous fusion has to be again run down in another crucible and poured into an ingot mould before the refiner will consent to take his assay from it. In this latter process the whole work is performed in one fusion, and the expense of a new crucible saved thereby. The flux employed in the reduction of the metal is also considerably reduced. The work is performed in the following manner:

Take a plumbago crucible of the ordinary shape, and capable of holding the required mixture; put the lemel into it, and then place on the top one ounce of finely powdered carbonate of soda; this is all the flux the mixture requires, and it is then ready for the furnace. When the lemel has become properly fused, for facilitating which it is repeatedly stirred with a thin iron rod, it is withdrawn and poured into an ingot mould prepared for it, as previously described. The flux and other organic matter, which always accumulates upon mixtures of this kind, is held back by the timely application of a thin piece of flat wood to the mouth of the crucible. After the withdrawal of the bar of metal from the ingot mould, it is cooled and weighed, and it is then ready for the operations of the refiner.

**Weight of Balance.**—Concerning the balance, the weight of which must stand in a correct proportion to the power of the spring, the following may be remarked: Too light a balance is too much influenced by the changes in spring force, which result from the impossibility of making so small a mechanism with mathematical precision. By an increase of the power of the spring, the motion of too small a balance is accelerated, by a decrease it is retarded, and such irregularities of rate, it is evident, do not permit a satisfactory adjustment.

Albert Muller, jeweler, Dundee, Ill., is assignee of Edgar C. Hawley, financier.

L. D. Merrill, Sparta, Wis., has purchased the stock of P. Scholler, Tomah, Wis., and will put it in a new jewelry store in the Banks & Cole building.



HIGHEST  
AWARD  
WORLD'S  
COLUMBIAN  
EXPOSITION.

# RUDOLSTADT

## ART POTTERY.

CONTAINS all the elements re-  
quired as to designs, deco-  
rations and workmanship, in a high  
grade of Art Goods adapted to the  
Jewelry Trade, and yields a larger  
margin of profit than any other  
class of Pottery.

**L. Straus & Sons,**

SOLE AGENTS,  
42-44-46-48 Warren Street,  
116 Chambers Street,  
NEW YORK.



**..THE LATEST..**  
Sterling Silver Novelty,  
**CIGAR CUTTER**  
AND **KEY RING** COMBINED.  
Patented Nov. 20th, 1894.  
WITH OR WITHOUT CHAIN.

MADE ONLY BY  
**ENOS RICHARDSON & CO.,**  
23 Maiden Lane, New York.

## CAMPBELL-METCALF SILVER CO.

FACTORY:  
STEWART ST.,  
PROV., R. I.

N. Y. OFFICE:  
2 MAIDEN LANE.

SAN FRANCISCO:  
112 KEARNY ST.

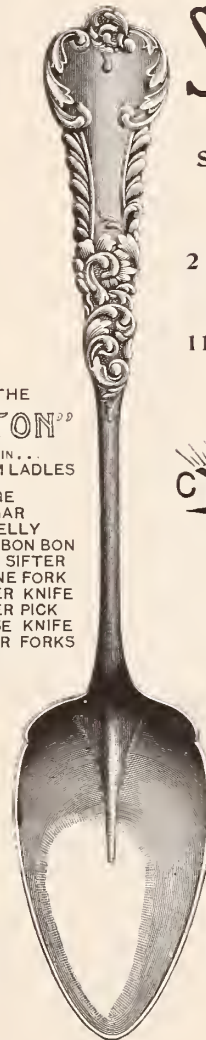

THE  
"ETON"  
... IN ...  
CREAM LADLES  
ORANGE  
SUGAR  
JELLY  
BON BON  
SUGAR SIFTER  
SARDINE FORK  
BUTTER KNIFE  
BUTTER PICK  
CHEESE KNIFE  
OYSTER FORKS  
ETC.



OUR  
"ETON"  
AND  
"STUART"  
PATTERNS  
ARE IMMENSELY  
POPULAR  
AND SELL AT SIGHT  
WRITE DIRECT  
TO FACTORY FOR  
SAMPLES  
AND PRICES.

## FANCY

.. IN ..

SCARF PINS

AND LINKS.

Dudes, Chinamen, Policemen, Sailors, Orators, Cadets, and all other Shapes Made.  
SEND FOR SAMPLES.



## FIGURES

STERLING SILVER,

Enameled in Colors.

QUICK SELLERS.

If your Stock does not include our **GOLCONDA GEM** Line you are losing sales. This Stone is Mounted in Studs, Scarf Pins, etc., in Solid Gold and Plate.

If your jobber doesn't keep these goods write us and we will send you the address of a jobber in your vicinity who does. Every card bears the words "THE GOI CONDA GEM, Reg'd." all others said to be "equally as good" are spurious. Bear this fact in mind.

**R. L. GRIFFITH & SON, - PROVIDENCE, R. I.**

*We Know*

THAT WE CAN GIVE YOU BETTER  
RETURNS ON YOUR OLD GOLD  
AND SILVER OR WASTE THAN  
ANY ONE ELSE. TO PROVE  
THIS STATEMENT GIVE US  
ONE TRIAL.



**GEO. M. BAKER,**

GOLD AND SILVER REFINER  
AND SWEEP SMELTER. **PROVIDENCE, R. I.**



# FERDINAND BING & Co.,

106 GRAND ST., N. Y.

NEW DESIGNS IN —————

China Clocks and Gilt Bronze Sets, Fine Painted  
 Dresden Goods in Vases, Cups and Saucers, and Plates;  
 Cararra Marble Statuary, French Cabinets and other  
 Fancy Furniture.

## YOUR HOLIDAY TRADE

... WILL REQUIRE ...

### Muff Holders.

**WE HAVE THEM!**

Prices range from \$12 to \$20 per dozen. All complete. Sterling Silver Mountings, Satin Ribbons, stylish and taking.

OUR LINE OF

**QUICK SELLING NOVELTIES**

INCLUDES

**CZARINAS, BELTS,  
 GARTERS, SUSPENDERS,  
 BON BON SPOONS, Etc.**

All in Sterling Silver. Write us!

**CODDING BROS. & HEILBORN,  
 NORTH ATTLEBORO, MASS.**

NEW YORK OFFICE, CHICAGO OFFICE,  
 C. A. Vanderbilt, 178 Broadway. F. A. Buck, 103 State St.



## A RICH COMBINATION.



Cut Glass Bowl on Artistic Solid Cast Brass Base. Finished in Matt and Burnished Gold.

The Combination of Gold and Cut Glass shown above was a most daring one. Its INSTANT and INCREASING SUCCESS is a proof that the trade appreciates it as a SELLER. Write us at once for full particulars and prices if you are not carrying it.

A Specially Good Thing for Jewelers.

**T. B. CLARK & CO., Inc.,**  
 860 Broadway, N. Y.,

Factories, HONESDALE, PA.

N. E. Cor. 17th St. & Broadway

**Paul Jeanne,** EIGHTEENTH STREET and 4<sup>TH</sup> AVE., N. Y.  
 (Bradley Building.)

MANUFACTURER OF

FINE DIAMOND JEWELRY.

## MUSICAL BOXES

FACTORY AT AUBERSON, SWITZERLAND.  
 ESTABLISHED 1828.

**E. L. CUENDET,** 21 John Street, New York City.

Send for our New Illustrated Catalogue for 1894, containing Full Particulars and Price Lists.



## Porcelains, Old and New.

THE art of making porcelain has never entirely decayed in China, says a writer in the *New York Sun*. All of our amateurs and students of Oriental art have not been aware of this fact; but there is at the present moment an excellent opportunity to acquire definite and sufficient knowledge of it. Some one in Shanghai described as "an expert collector, long a resident of China," has sent some 600 pieces of porcelain to the American Art Association. They have been on exhibition during the past week and are presently to be sold at auction.

Heretofore in the many sales that we have had of Oriental porcelain the various objects have been set forth as not modern. That is to say, they antedated the present century, or at least belonged to the first quarter of it. In the catalogue of the present collection a very large number of the specimens are frankly described as of modern manufacture. We fear that many persons who have been acquiring examples of Oriental porcelain during recent years will be very much disturbed, and will have great difficulty in distinguishing between these fabrications of our own day and those which they had been led to ascribe to a more or less remote antiquity.

In all the Chinese literature of the porcelain of antiquity each period is mentioned as assiduously imitating the productions of a preceding period. According to the historians, the art culminated in the first half of the fifteenth century, since which time the potters have been imitative rather than creative. So far, however, as the actual knowledge on the part of foreign nations is concerned, it culminated during the reign of the first of the Manchurian or Tartar conquerors of China, who held peaceful sway over the Flowery Kingdom. That was in the years between 1661 and 1722, when a literary, poetic, and beneficent tyrant reigned under the title of Khang-hsi, which being translated means Peaceful Joy, a pleasant title for a gentleman whose family had just devoted fifty years of steady work to stamping out the lives and sequestering

the substance of two hundred and fifty millions of people. At any rate, the porcelain of his reign was of wonderful beauty and comprised practically all the standards of rarity and excellence that distinguish modern collections. It is seen in all the great museums of Europe. From it the whole ceramic industry of Europe had its earliest artistic beginnings and derived the style and character that impress it to the present day. From it were chosen the choicest and the most valuable objects of the household decoration of Europe for the last two hundred years, and in our own country it has made its way steadily ever since it began to appear in the colony of Virginia, since George and Martha Washington owned their share of Oriental china now shown in the National Museum, and since Yankee skippers brought blue and white vases to their wives and sweethearts from the shores of far Cathay.

In the reign of Peaceful Joy they did not neglect the graceful art of imitation, not to say counterfeiting. We have the historian's chronicle for it, and we have the objects themselves. They follow the creations of the extinct dynasty of the Mings in form, in color and design. For the most part they are easily distinguished by their modern elegance, delicacy, and refinement of detail, as opposed to the archaic strength, vigor, and originality of the older period. But in only too many instances the imitation was so good that no one could discriminate, and the modern vase bore its fifteenth or sixteenth century date, mark, style, and stamp just as bravely as the genuine article.

It was thought that this imitative work died out with the last century. In the reign of the Emperor Yung-Chung, who followed Peaceful Joy, and of Kien-Lung, who almost rounded out the century, it seemed to have gradually fallen into disuse, until, finally, the Chinese potters devoted themselves solely to elaborate and mostly mercetricious decoration and to purely commercial porcelain for the European market.

The disillusionment is complete. The art has been revived, and it is quite evident that the Chinese are still skilled in the potter's art beyond all other nations. Euro-

pean nations have, of course, made wonderful progress since they learned from China the first principles of the manufacture of porcelain, the relation of *kaolin* to *petuntse*; but there are secrets of the kiln that are still as impenetrable as they were two centuries ago, but which, for the Chinese, are very far from being, as was supposed, a wholly lost art. The Decks, the Havilands, and all the great potters of Europe have spent millions in the effort to produce certain of the Chinese colors that distinguished the porcelain of two hundred years ago. They failed wholly; but here in this collection, so kindly forwarded by the "expert collector" of Shanghai, we find that they can produce them to-day with just such facility as the market for them may require.

The chief difference that we discern between the present display and certain of its predecessors lies in the frankness of its catalogue. It does not appear to make the slightest difference to this "expert collector" that so many of the objects are already domiciled here and well established in their antiquity. He goes on labeling his own selections as modern, and asks people to buy them for what they are worth. It is less of a surprise to those who gave careful attention to the Baron von Brandt's collection than it is to those who did not. That collection contained a number of beautiful pieces of porcelain, superb reproductions of older examples, but they bore in Chinese characters, with exemplary candor, the inscription of the Emperor now reigning, Kouang-Ssu.

As predicted in THE CIRCULAR some months ago, the new patterns introduced in the cut glass of L. Straus & Sons, 42-48 Warren St., New York, have attained a marked success, and the manufacturers state that they are having much difficulty in filling the rush of orders now coming in. The Elysian and Majestic, the new, rich, medium priced patterns, have proved particularly adapted to the jewelers, holiday trade while the Premier and Chancellor have become the leaders in popularity among the high grade patterns of this year.

**The Connoisseur.**

*(Continued from page 43.)*

**The Rambler's Notes.**

WHAT THE RAMBLER SAW AND HEARD AMONG THE DEALERS IN ART POTTERY, CUT GLASS, BRONZES, ETC.

**LIMOGES CHINA NOVELTIES.**

**L**IMOGES CHINA novelties are the most extensive of the holiday lines opened by Hinrichs & Co., 31 Park Place, New York. Photo frames, trays of all sizes, ring holders, boudoir sets, large and petite bonbon and powder boxes, and similar articles well suited for presents are necessarily shown in a great variety of styles and colors and in gilt, floral, figure and scenic decorations. Dainty French boudoir lamps form another attractive line. They are somewhat smaller than the princess size and are shown in crystal, decorated china, cut glass, metal and mounted Sèvres. All have decorated globes.

**THE USE OF MARMORINE.**

**T**HE illustration shows a sensible and effective manner of cleaning statuary, particularly as the maid is represented as using Marmorine, the only preparation on the market that will thoroughly cleanse marble, alabaster, pottery, etc. This preparation for which Geo.

Borgfeldt & Co., 18-22 Washington Place, New York, are the selling agents, is the result of many years' experiments by Julius

preparations, it makes marble and alabaster perfectly white after using.



Millhagen, an expert repairer of marble statues. Unlike soaps or other cleansing

**CHRISTMAS BRIC-A-BRAC.**

**L**AZARUS ROSENFELD & LEHMANN, 60 Murray St.,

New York, have been replenishing their assortments of their own Victoria ware in order that the stock be replete particularly in all the various lines of artistic pottery and novelties suitable for Christmas trade. Their collection now embraces in addition to the former rich and moderate styles, some artistic decorations entirely new to this pottery of this ware.

One of these shown on pitchers, vases and oddly shaped urns, consists of panels containing the portrait of some person celebrated in French history, similar to the decoration on the plates and trays mentioned in this column, Nov. 21. In the pottery however, the cream background of the panel is set off by the beautiful shaded green body color of the vase; gold handles complete the ornamentation.

THE RAMBLER.

George L. Morningstern, a lapidary employed in the factory of Sinnock & Sherrill, in Newark, N. J., died suddenly of apoplexy, Tuesday, Nov. 27th. Mr. Morningstern was stricken while at work and died before he arrived at the hospital. He had been employed at the factory for many years.

**THE SOUL OF THE DIAMOND.**

A PASTEL IN PROSE.

**I.**

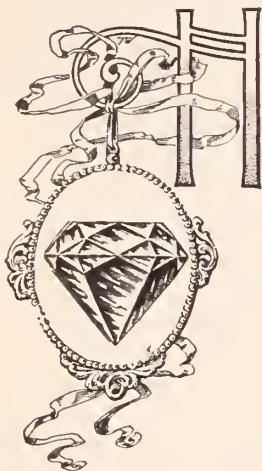

**H**UNDREDS of uncounted years it lies hidden from eye of man, enclosed in the baser mould in the bosom of Mother Earth, little dreaming that within its soul resides the quintessence of brilliancy and purity, and that man prizes it above all things of material value.



**II.**

In the seeking for riches, after the prospector has discovered its lair, after organized labor has delved for it and unearthed it, from a nameless pebble it is a modicum of wealth, though in aspect but a dirty mite of quartz.

**III.**

Traveling over the main, thousands of miles, it reaches the works of **OPPENHEIMER BROS. & VEITH, NEW YORK**, whose cutters and polishers lend their art, bringing forth its true nature and making it "a gem of purest ray serene," the superlative of beauty, the zenith of purity, emblem of riches, token of innocence.





# CARBORUNDUM.

## Net Retail Price List of Carborundum Wheels.

ACHESON'S PATENT, February 28th, 1893.

Diam. in Inches	THICKNESS IN INCHES.																Rev. per Minute.	
	1/4	3/8	1/2	5/8	3/4	7/8	1	1 1/4	1 1/2	1 3/4	2	2 1/4	2 1/2	2 3/4	3	3 1/2		4
1	\$.15	\$.18	\$.20	\$.23	\$.25	\$.28	\$.30	\$.35	\$.40	\$.45	\$.50	\$.55	\$.61	\$.65	\$.70	\$.80	\$.90	18,000
1 1/2	.18	.22	.25	.28	.31	.33	.35	.40	.45	.50	.56	.62	.67	.73	.78	.90	1.00	14,000
2	.21	.25	.30	.34	.37	.40	.42	.46	.52	.58	.65	.70	.77	.85	.91	1.00	1.20	11,000
2 1/2	.25	.30	.37	.42	.46	.48	.50	.55	.60	.67	.75	.80	.91	.98	1.05	1.20	1.40	8,800
3	.30	.38	.45	.50	.55	.58	.60	.65	.70	.78	.85	.95	1.05	1.15	1.25	1.45	1.65	7,400
4	.65	.70	.75	.81	.85	.90	.95	1.10	1.30	1.50	1.65	1.80	2.00	2.15	2.35	2.70	3.05	5,500
5	.85	.90	.95	1.05	1.15	1.25	1.35	1.65	1.90	2.20	2.45	2.75	3.05	3.31	3.55	4.15	4.65	4,400
6	1.10	1.20	1.25	1.45	1.60	1.80	1.95	2.35	2.75	3.15	3.55	3.95	4.33	4.75	5.15	5.95	6.75	3,700
7	1.35	1.55	1.70	1.90	2.10	2.35	2.60	3.15	3.70	4.25	4.80	5.35	5.75	6.45	7.00	8.10	9.20	3,160
8	1.65	1.90	2.15	2.45	2.75	3.05	3.35	4.05	4.80	5.50	6.25	6.95	7.65	8.35	9.10	10.50	12.00	2,750
9	2.01	2.40	2.65	3.10	3.40	3.80	4.15	5.10	5.45	6.90	7.80	8.75	9.65	10.55	11.45	13.25	15.10	2,450
10	2.45	2.80	3.25	3.70	4.15	4.65	5.10	6.25	7.40	8.50	9.60	10.70	11.85	12.90	14.05	16.30	18.55	2,200
12	3.60	4.00	4.40	5.10	5.80	6.50	7.20	8.80	10.40	12.00	14.60	15.20	16.80	18.41	20.00	24.55	26.40	1,830

CARBORUNDUM was awarded both a Medal and a Diploma at the World's Columbian Exposition in recognition of its merits as an Abrasive, the hardness being greater than any other abrasive material.

The wheels are made with a vitrified bond, and pressed under hydraulic pressure. Those over three inches in diameter are turned up after firing. The same numbers are used to designate the degrees of fineness, as are used with Emery, and the wheels are made in seven degrees of hardness, marked SSS, SS, S, M, H, HH, HHH, from extremely soft to extremely hard.

In ordering, state diameter, thickness, hole, number and hardness.

Monongahela, Pa., U. S. A.

THE CARBORUNDUM COMPANY.

Hones, Slabs, Files.

Cut = This = Out.

## BOYLE, DAVIS & GOODMAN,

SPECIAL AUCTIONEERS for the Legitimate Trade only.

63 Fifth Avenue  
NEW YORK.

611 Pennsylvania Ave.,  
WASHINGTON, D. C.



S. A. BOYLE.



W. M. DAVIS.



CHAS. P. GOODMAN.

WE PAY ALL OUR OWN EXPENSES. GUARANTEE TO MAKE YOUR SALE WITHOUT LOSS.

SEND FOR OUR BUSINESS PAMPHLET.

CONSULT US BEFORE PLACING YOUR SALE. ADDRESS ALL CORRESPONDENCE TO OUR WASHINGTON OFFICE.

## CHRYSO-CERAMICS, GOLD COVERED PORCELAIN.

M. & E. HEALEY,  
1122 CONNECTICUT AVE., WASHINGTON, D. C.  
MEDAL AT WORLD'S COLUMBIAN EXPOSITION.

WOOD & HUGHES,  
STERLING SILVERWARE MANUFACTURERS  
New York Agents for the Derby Silver Co. N. Y.  
FINE QUADRUPLE PLATED WARE,  
No. 16 JOHN STREET, NEW YORK  
206 Kearney St., San Francisco, Cal.  
HASKELL & MUEGGE, Agents.

## AIKIN, LAMBERT & CO.,

CHICAGO BRANCH: 103 State Street.

No. 19 MAIDEN LANE, NEW YORK.

Manufacturers and Exporters  
Gold Pens, Holders, Pencils,



Toothpicks and Novelties.

MERCANTILE

FOUNTAIN PEN.



# Perfect Construction

AND

## SUPERIOR FINISH

MAKE OUR PRODUCTIONS OF  
HIGHEST GRADE.

JEWELERS and  
FANCY GOODS DEALERS

will find in our new line of

### Art Metal Goods

many articles specially adapted  
to their trade.



### The Finest Line of Banquet Lamps

EVER PRODUCED.

Fitted with the Celebrated "B. & H." Burner.

New and Attractive Designs and Finishes. Sure to be Ready Sellers.

We will send you our Little Book, giving more information, if you desire, and will be glad to have you visit our Salesrooms and see the Goods.

## BRADLEY & HUBBARD MFG. CO.,

NEW YORK, PHILADELPHIA, BOSTON, CHICAGO,  
26 PARK PLACE 710 BETZ BLD'G. 160 CONGRESS ST. 204 MASONIC TEMPLE  
TO 21 BARCLAY ST. FACTORIES AND OFFICES, MERIDEN, CONN.

## Now that we have touched bottom

And business generally is improving every GOOD RETAIL JEWELER should make his stock attractive and so invite customers. He can buy nothing more sure of sale than

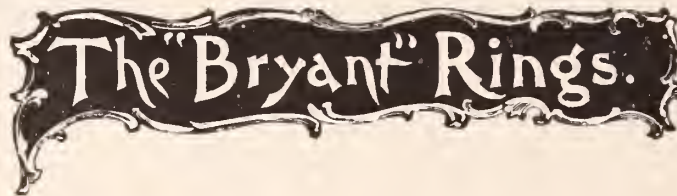

of standard quality, at moderate cost, and of new and taking styles. If not called upon by our travelers send your orders direct to

**M. B. BRYANT & CO.,**  
10 MAIDEN LANE, NEW YORK.

IMPORTERS OF  
**DIAMONDS.**

JOBBERS IN  
Watches, Jewelry, Chains,  
NOVELTIES, ETC.  
Latest Designs. Lowest Prices.

## The Other Side of Life. THE POET AT CHRISTMAS.

She spoke of Santa Claus, alack!  
It made me feel upon the rack.  
She'd like, she said, a sealskin sacque,  
Or else a locket.

I felt the hot blood upward rush  
(It was not so when I was flush).  
What could I do but sit and blush,  
With empty pocket?

Ah, could she know the poet's woes,  
Who sings in verse but lives in prose,  
She'd choose some cheaper things than those  
To fill her stocking.

But, after all, I'll not complain;  
Man cannot quite his fate ordain.  
Come here, my dear old watch and chain,  
We'll go a-hocking.

—Christmas Judge.

NODD.—I had an awful row with my wife this morning over a silver penholder she recently gave me.

TODD.—What was the trouble?

NODD.—She caught me using it.—  
Brooklyn Life.

"What is this?" asked Hicks, picking up a small bit of velvet and jet.

"That," replied his wife, "is my new full-dress bonnet; what did you think it was?"

"I didn't know but it was a washer to go on a hatpin."—New York World.

CHARLIE-BOY—Any news regarding the robbers?

O'BRIEN.—Naw; but they've found the tray of diamonds.

CHARLIE-BOY.—Where did they find it?

O'BRIEN.—They found it in a pack of cards, sonny.—Judge.

"Have you heard of the latest invention in clocks?" she asked sweetly.

"No," replied Mr. Slogo.

"It is very ingenious. It has a phonograph attachment which calls off the hours."

"Wonderfully clever!"

"Yes; and at a quarter of 11 it says 'good night.'" He glanced at his watch, which told of half-past ten, and in a few moments had fled into the darkness.—  
Washington Star.

**H. M. RICH & CO.,**  
Jewelry · Auctioneers,  
21 School Street.  
BOSTON. MASS.

**AIKIN-LAMBERT**  
JEWELRY CO.,  
19 Maiden Lane, New York.  
CHICAGO BRANCH: 103 STATE ST.



# HINRICHS & CO.,

29 & 31 Park Place, N. Y.

## HOLIDAY GOODS FOR JEWELERS.

ITALIAN MARBLE BUSTS,  
PARIAN BUSTS and FIGURES,  
BISQUE FIGURES and GROUPS,  
FRENCH CHINA CRACKER JARS,  
CHOCOLATE POTS, TRAYS, BOWLS,  
SOUVENIR A. D. COFFEES, TEAS, Etc.

ST. GERMAIN AND GERMAN-AMERICAN STUDENT LAMPS.

## BRIC-A-BRAC AND ART POTTERY.

SEND FOR CATALOGUES.

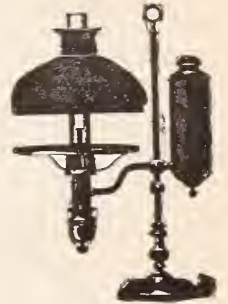

**TOWEL**  
MANUFACTURING COMPANY.  
MANUFACTURERS



OLD ENGLISH STRAWBERRY FORK

STERLING SILVER TABLE WARE,  
IN A COMPLETE ASSORTMENT.

149-151 STATE STREET CHICAGO ILL.

Newburyport, Mass.

## BURGLARY INSURANCE.

**Fidelity AND Casualty Co.**  
OF NEW YORK  
INSURES Safes and their Contents  
Against Burglary.

For Particulars, address the Company,  
40-146 BROADWAY, NEW YORK.

# The Best Chatelaine is the Lady Racine.

## STEEL CASES & SILVER CASES.



10 LINE.

- Made in 10 Line Open Face.
- “ 11½ Line Open Face and Hunting.
- “ 13 Line Open Face and Hunting.

THE SILVER CASES ARE 0.935 FINE.  
THE MOVEMENTS HAVE 10 JEWELS  
THE ENGRAVINGS ARE CHOICE.



13 LINE

## MADE IN 12 LINE OPEN FACE.

In Silver Cases only.

Case 0.800 Fine with a 6 Jewel Movement.

Expressly Gotten Up to Suit the Times.



12 LINE

A GOOD Chatelaine Watch at a LOW PRICE.

Do not fail to ASK YOUR JOBBER FOR THE NEW  
12 LINE LADY RACINE in 0.800 Cases.

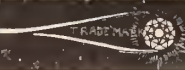

**SAPPHIRES.**

**E. KIPLING,**

182 Broadway, New York.

ELEVATOR ENTRANCE, 2 JOHN ST.

**U. S. SMELTING & REFINING WORKS,**

Sweep Smelting and Assaying, Platinum in Plate and Wire. Chemically Pure Copper. Ore and Bullion Assays a specialty.

Highest prices paid for old gold and silver. Sole manufacturers of Phoenix Flux and Eureka Alloy.

M. WOLLSTEIN, 25 John St., New York.



OUR SPECIALTY  
The Largest Stock of  
**CHIMING**  
AND  
**STRIKING**  
**HALL CLOCKS**

ever shown.

**Chas. Jacques**

CLOCK CO.,  
22 Cortlandt Street,  
NEW YORK.

**S. F. MYERS & CO.,**

Manufacturing and  
WHOLESALE JEWELERS,  
1895 Issue, No. 39.

**OUR ROYAL CATALOGUE**

Illustrates all that is new, unique  
and desirable in

everything that pertains to jewelry.  
600 pages, size of this publication.  
Free to dealers.

SEVEN DOUBLE FLOORS.  
TWENTY-TWO DEPARTMENTS.

Myers Buildings, 48-50 Maiden Lane,  
33-35 Liberty St., New York.

**B. & W. B. SMITH,**  
220 W. 29th St., New York.

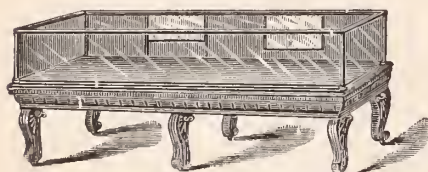

Improved Dust-Tight Counter Cases,  
Perpendicular Sliding Doors.

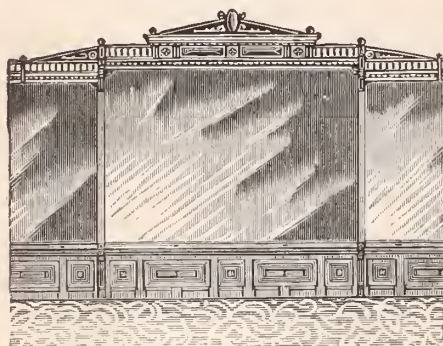

Improved Dust-Tight Wall Cases.  
Furnished with Improved Shelving and arranged for Electric Lighting.

**BORLOZ FILES.**  
**L. COMBREMONT**  
IMPORTER OF  
Tools and Materials,  
45 Maiden Lane, NEW YORK.

Sold by all wholesale dealers at manufacturer's price.

**A. N. CLARK & SON**  
PLAINVILLE  
CONN.

Manufacturer of the Celebrated  
**LOOP WATCH KEY.**

The Best for the Price in the World.  
CROSBY'S JEWELING TOOLS IMPROVED.

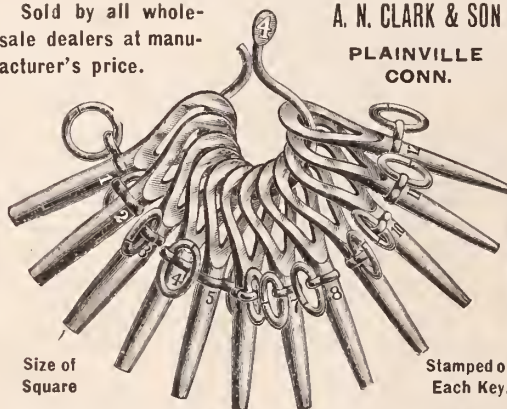

Size of Square

Stamped on Each Key.



Will quote royalty or price for the manufacturing of articles of real worth.

**HAGAN, WHITE & CO.,**  
MANUFACTURERS OF  
**GOLD AND SILVER MOUNTED CANES, UMBRELLAS & NOVELTIES.**  
RICH AMERICAN CUT GLASS, SILVER MOUNTED.  
248 WEST 23D STREET, NEW YORK.

**L. LELONG & BRO.,**  
GOLD AND SILVER  
Refiners, Assayers AND Sweep Smelters,  
SOUTHWEST CORNER HALSEY AND MARSHALL STREETS,  
**NEWARK, N. J.**  
SWEEPINGS A SPECIALTY.

**ALBERT LORSCH & Co.,**

37 MAIDEN LANE, NEW YORK.

Branch, 167 Weybosset Street, Providence, R. I.

IMPORTERS OF DIAMONDS,

Rose Diamonds, Rubies, Sapphires, Emeralds, Opals, Moonstones,  
Fancy and Imitation Stones, Novelties.

SOLE OWNERS AND IMPORTERS OF

*The Sumatra Gem,*

REG'D. UNEQUALLED IN  
BRILLIANCY AND  
HARDNESS

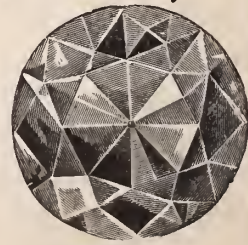
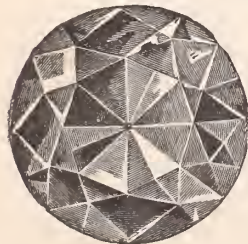

HIGHEST AWARD AT THE COLUMBIAN EXPOSITION, CHICAGO, 1893.

**IT PAYS** TO KEEP IN TOUCH WITH TRADE AFFAIRS. For 4c. a Week will do it. **Subscribe.**  
THE JEWELERS' CIRCULAR,

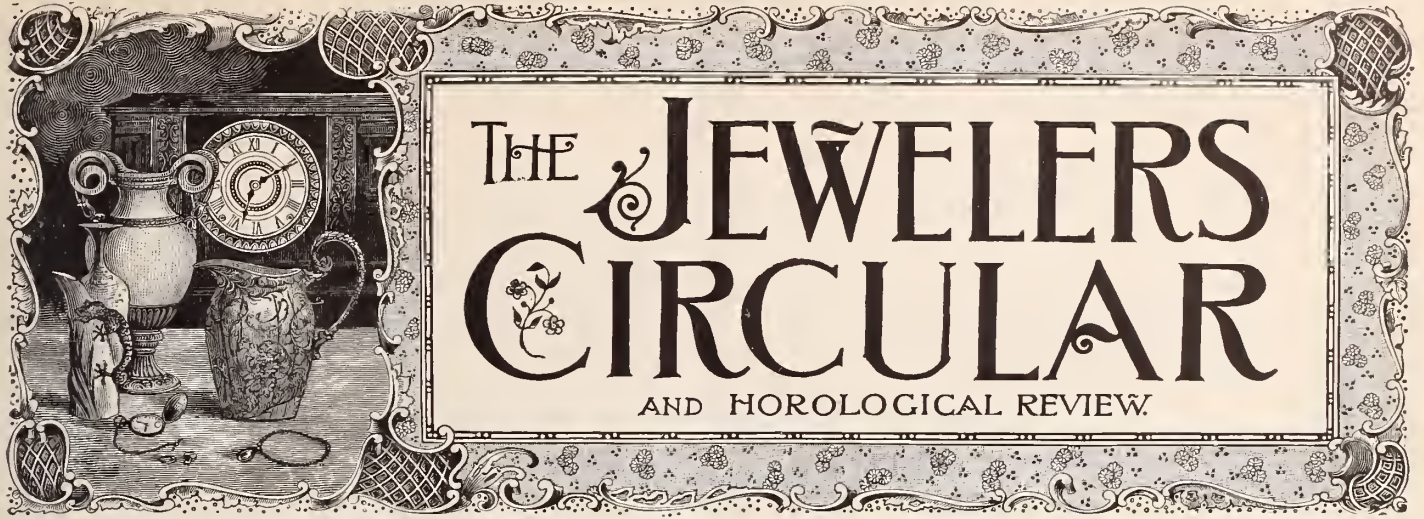

# THE JEWELERS CIRCULAR

AND HOROLOGICAL REVIEW.

Copyright by THE JEWELERS' CIRCULAR PUB. CO.

189 Broadway, New York.

Entered at the Post Office in N. Y. as second-class matter.

VOL. XXIX.

NEW YORK, WEDNESDAY, DEC. 19, 1894.

No. 21.

## THE FLOWER IN JEWELRY AND SILVERWARE.

### PART I.

PARIS, France, Nov. 15.—Under the name *La Fleur*, a small Exposition, clusters. Let us also mention a pretty formed of a gathering of fine topazes. A piece of delicate workmanship (Fig. 2)



FIG. 1. DIADEM OF LAUREL LEAVES, BY MELLERIO.

nots and lilies-of-the-valley gracefully entwined, the former made of turquoises, the

which may be considered as a prelude to an important one of the same kind, has just been opened at the Galerie Petit. Water-colors, pastels and paintings, showing an infinite variety of flowers, are hung on the walls all round. Works of art in bronze and pottery are scattered about the rooms, resting on elegant tables. Gold, silver and jewelry pieces are exposed in glass cases of various sizes. These articles reproduce in a natural or a conventional style not only flowers, but also vegetables, fruits and plants of all kinds. Boucheron, Gustave Sandoz, Leturcy and others exhibit graceful sprigs of flowers formed of diamonds or colored stones, and small fancy articles adorned with floral *motifs* in enamel. Christofle & Co.'s glass case contains 83 different articles in oxidized or gilt silver, reproducing in their shape or decoration vegetables, fruits or flowers.

Fig. 1 reproduces a remarkable diadem made at Mellerio's. It consists of diamond laurel leaves beautifully drawn, assembled in threes, with two black onyx pearls imitating the berries of the laurel, between the



FIG. 2. ROSE BRANCH BY REGIUS.

latter of brilliants, with a diamond daisy on the clasp, the heart of the flower being

is a rose branch in oxidized silver, by Regius. It is impossible to imitate more perfectly the pretty folds of the queen of flowers. The artist must have copied it directly from nature, as a painter should a portrait. With a hammer he has prepared sheets of silver, and twisted them with delicate pincers into the shape of buds and full blown roses; he has fashioned the leaves and cut them from another sheet; then he has assembled the whole with soldering, and carefully bent the stalk and the stems. The jewel seems to have sprung up spontaneously under the experienced touch of a skilful hand; yet how many pieces of twisted metal the artist had to throw into the melting pot before he could be satisfied with his work!

Boucheron exhibits a sprig of corn poppies and a spray of fuchsias in diamonds; a bookmark in *cloisonné* enamel consisting of three lanceolate leaves of different sizes overlapping each other, a bunch of mulberries being thrown across the base to serve as a handle; a set of ice spoons with shallow bowls in translucent enamel finely *cloisonné*,

ESTABLISHED 1842

*Samuel Little, Pres't* *Rufus B. Carr, Gen'l Man'gr**Arthur M. Little, Treas'r*

OFFICE OF  
**THE E. HOWARD WATCH & CLOCK CO.**

**FINE WATCHES & CLOCKS.**

383 WASHINGTON ST. BOSTON. 34 WASHINGTON ST. CHICAGO.

E.V. CLERGUE, Agent.

41 MAIDEN LANE, NEW YORK.

*New York!*

RETAIL JEWELERS,

GENTLEMEN--WE HAVE RECEIVED many letters from THE TRADE throughout the country from which we judge that an ERRONEOUS IMPRESSION has been given that HOWARD WATCHES cannot be obtained from Jobbers.

We therefore take this method of informing our friends, the Retail Jewelers, that any legitimate Jobber in the country can supply Howard Watches of ANY GRADE OR SIZE desired.

If your Jobber fails for any reason to fill your orders, write directly to us and we will see that you are supplied.

We have also received complaints that Retailers fail to get satisfaction when they send Howard Watches to their Jobbers for repairs, &c., and we earnestly request that any Retailer having trouble of any kind in regard to the PURCHASE, SALE or REPAIRING of our Watches, communicate directly with us.

We will gladly correspond with any dealer upon any point in connection with Howard Watches or Clocks.

The American Watch is the best watch in the world and WE HAVE ALWAYS MADE, ARE MAKING and WILL MAKE the finest American Watch.

We have a thoroughly organized repair department and will now do repair work on Howards at ACTUAL COST.

THE E. HOWARD WATCH AND CLOCK CO.



# Foster & Bailey,

MANUFACTURING JEWELERS AND SILVERSMITHS,

100 Richmond St., Providence, R. I.



**STERLING SILVER  
MANICURE SETS,**

**925-1000 Fine,**

**With Shoe Horn and  
Shoe Buttoner.**

MADE OF THE BEST STEEL PARTS.

Put up in Fine Leather Roll,  
Lined with Dark Green Velvet  
and Having Beautiful Silk Flaps  
to fold over.

When Rolled Up it is Soft,  
Pliable, and Just the Thing to  
Pack in a Grip.

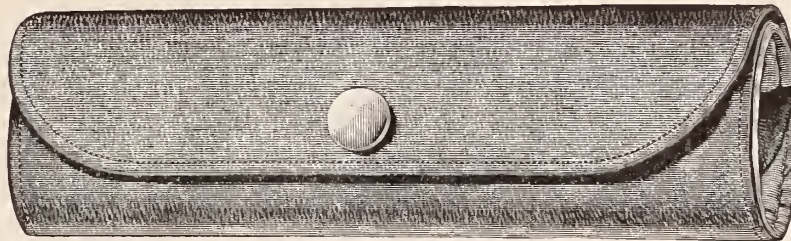

SET ROLLED UP—REDUCED ONE HALF EACH WAY.

Manicure Goods, Emery  
Strawberries, Pen Wipers,  
Garters, Paper Cutters, Pock-  
et Combs, Match Boxes,  
Knives, Embroidery Scis-  
sors, Collarettes, Seals, Key  
Rings and Chains, Shoe But-  
toners and Glove Buttoners,  
and lots of other nice things,

Rolled Plate Watch Chains,  
1-10 Gold Vest and Dickens  
Chain, Chain Mountings,  
"Mount Hope" Buttons, Link  
Buttons, Locketts and  
Charms, Solid Gold Locketts,  
Bracelets, Neck Chains, Pins,  
Crosses, Earrings.



NO. 7 SET—REDUCED ONE HALF EACH WAY.

No. 138 File and Cuticle Knife Combined.  
" 139 Corn Knife.

No. 140 Button Hook.  
" 141 Shoe Horn.

No. 142 Nail Cleaner and Ear Spoon.  
" 143 Curved Scissors.

MANICURE SETS IN FINE KID CASES.

## STERLING SILVER SET No. 1, CONTAINS :

No. 54 - Tray.  
" 55 - Polisher Box.  
56 - Polisher.

No. 57 - - Paste Box.  
" 57 - - Powder Box.  
" 58 - - File.

No. 59 - Corn Knife.  
" 60 - Cuticle Knife.  
" 61 - Short Scissors

No. 70 - Long Scissors.  
Box.

No. 2 and No. 3 also in Sterling Silver, with less pieces, therefore cheaper in price. Nos. 4, 5 and 6 are in 1-10 Gold. All parts can be ordered separately, and all steel is of the best.

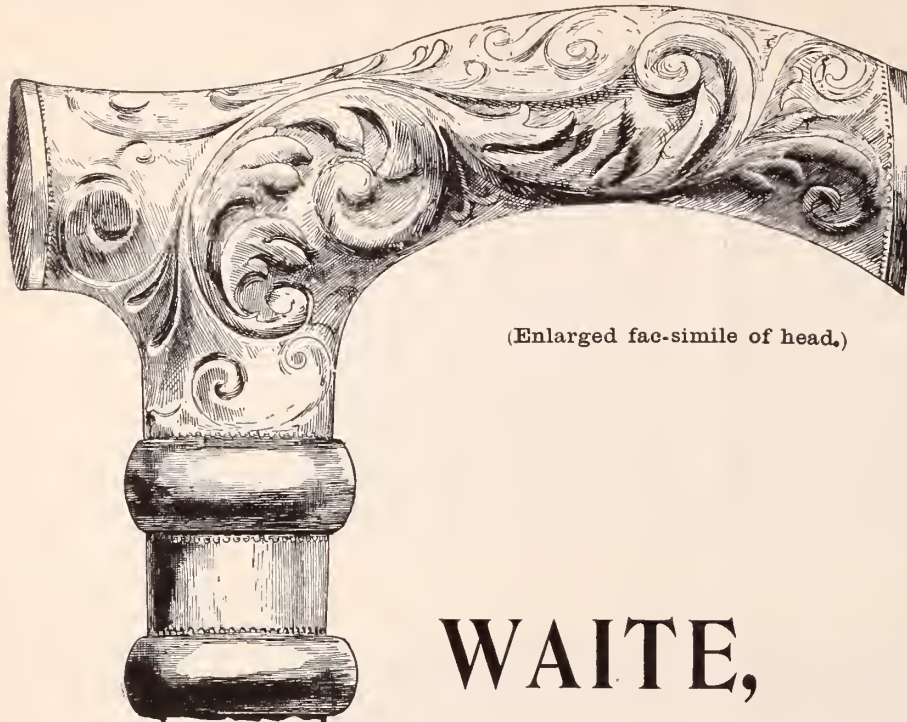

(Enlarged fac-simile of head.)

OUR  
CANE  
Stick  
And  
Lapel  
Pins.

PATENTED  
OCT. 23, 1894  
ARE  
THE  
PROPER  
THING.

HEADS  
ARE OF  
SOLID  
GOLD OR  
STERLING  
SILVER,

Artistically  
CHASED.  
STICKS  
ARE  
ENAMELED  
TO  
REPRESENT  
NATURAL  
WOODS.

THEY SELL AT  
SIGHT.

WAITE,  
THRESHER  
COMPANY,

Providence, R. I.

showing a great variety of exotic flowers and insects, the handles in gold being soberly adorned with floral designs; a cylindrical case (to contain 20 franc pieces) in rock crystal, having bunches of reeds in gold tied with cords, applied on it, etc.

A narcissus flower in diamond, forming a pin to wear on the corsage (Fig. 3) is a dainty piece, supple, fine, and true to nature. None but Massin could execute such an artistic *tour de force* in *joaillerie*.

There are, besides, a *traine* of diamond medlar tree flower; a sprig of thistles with emerald leaves, photo-frames which are wreaths of flowers in gold variously colored, etc.

(To be continued.)

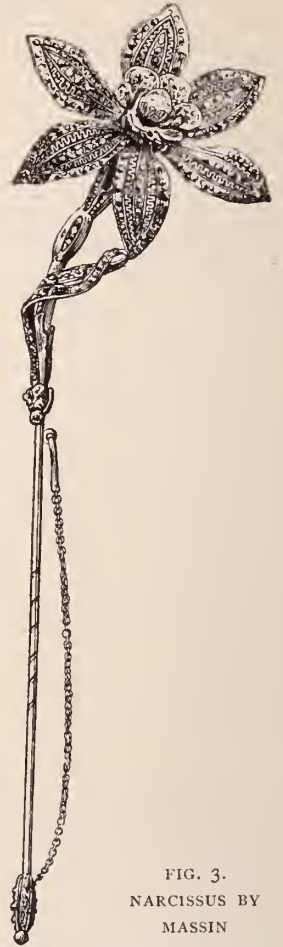

FIG. 3.  
NARCISSUS BY  
MASSIN

An Arabian Watch.

A FEW days ago a large bundle bearing many mysterious marks and labels was received at the home of Chief of Police Child, of Providence, R. I. When that official arrived home he discovered from the hieroglyphics that the package came "From the Fountain of Moses, El Teh a Trah Bani Israel," on the northeast coast of the Red Sea. Opening the box several curious and valuable articles were disclosed. Among other things carefully wrapped in foreign parchment was a very peculiar watch.

On one side was an American watch and on the other an Arabic one. The movement worked the hands on both faces and while the American face told the time in Rhode Island the other gave the correct hour of the day at the Fountain of Moses. The timepiece was an 18-size watch and the case was of a peculiar dark blue metal that answers the purpose in Arabia as silver does here. The head or pendant and bow were of gold and apparently of American or European manufacture. The face of the Arabic watch was covered with peculiar characters and the hands were of gold finely wrought.



*Pairpoint*

# MANUFACTURING COMPANY. Gold and Silver Plate



No. 3749. MATCH HOLDER.

WE ARE MAKERS OF THE  
LARGEST AND LOWEST PRICED

...LINE OF...

“Crown Pairpoint” China

Rich Cut Glass,

Fine Decorated Art Goods,

...TO BE FOUND IN THIS COUNTRY.



No. 4908. SMOKING SET.

“WHEN IN DOUBT”

--- BUY ---

✻ PAIRPOINT GOODS.

Factories, New Bedford, Mass.

## HOLIDAY NOVELTIES

::::: OF EVERY DESCRIPTION.

**FREE**

OUR LATEST

SILVERWARE CATALOGUE No. 10, or  
CUT GLASS CATALOGUE No. 11

Will be mailed you upon receipt of address

SALESROOMS :

NEW YORK, 46 Murray Street.

CHICAGO, 224 Wabash Avenue.

SAN FRANCISCO, 220 Sutter Street.

MONTREAL, P. Q., Temple Building.



No. 2832. KNIFE SHARPENER.

We sell to the legitimate Jewelry and Stationery trade only.



### CHOICE PAPERS

MAKERS OF

## FINE STATIONERY

For Correspondence, Wedding and Business Use, handsomely boxed, specially suited to the Jewelry Trade.

18 MURRAY STREET, NEW YORK.

## LATEST STYLES

... IN ...

## FINE JEWELRY.

GOLD BUCKLES,  
HAIR PINS,  
BACK COMBS,  
SIDE COMBS,  
NECK ORNAMENTS, Etc.

John A. Riley & Sloan Co.,  
Broadway and 17th Street,  
NEW YORK.

### 2 MEDALS AWARDED



AT  
WORLD'S  
FAIR,  
1893.

Providence Shell Works, Providence, R. I.  
Correspondence Invited.

# R. WALLACE & SONS MFG. CO.

## SILVERSMITHS,

WALLINGFORD, - - - - - CONN.



No. 20. FLASK.

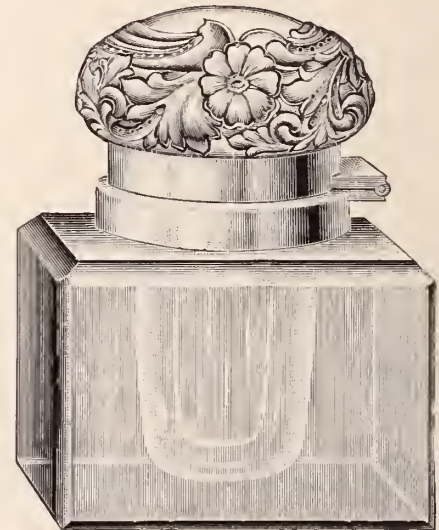

No. 53. INK BOTTLE.  
CHASED TOP.

Trade Mark.

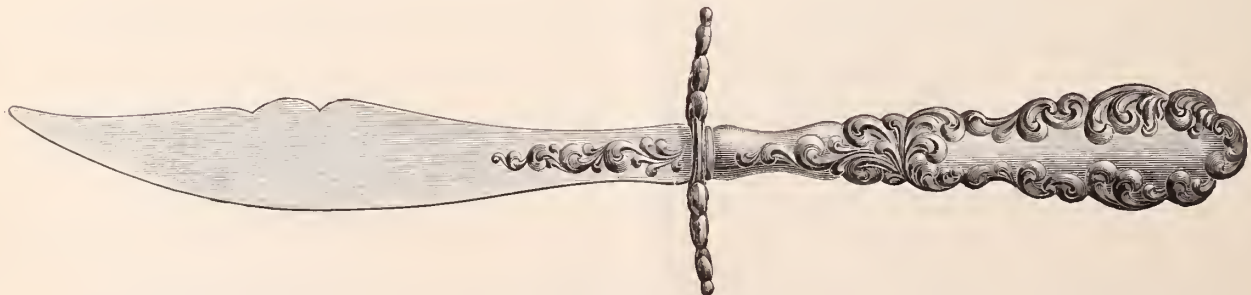

No. 39. PAPER CUTTER.

NEW YORK  
226 FIFTH AVENUE.

SAN FRANCISCO  
120 SUTTER STREET.

CHICAGO  
86 WABASH AVENUE.

## Fashions in Holiday Jewelry and Silver Novelties.

A LADY'S RAMBLES AMONG THE JEWELERS.

Silver plated marmalade frames are new.

The necessities of the typewriter are bringing out new styles of pointed erasers.

A brooch designed for a musician is a musical phrase with a tiny enamel violin at one end.

The union of silver gilt filigree and enamel is producing some of the most artistic articles now seen.

Long crescent brooches are made of two curving bars of gold, spanned by graduated leaves in tinted gold.

Silver lorgnette chains punctuated with colored beads have come to be numbered among things of importance.

Masculine vestments for women have brought forth ladies' vest chains, modeled after the inferior article.

Sleeve buttons grow longer and more slender, especially those in enamel with raised and broken edges.

The most convenient soap rack yet produced has just come out. It is an oval ring with crossbars on a low standard.

Silver supports and enclosures for the messy mucilage bottle are of consideration sufficient to be brought out in a variety of styles.

The wreath brooches of colored stones are exquisite. The semi-precious stones shine as handsomely in these designs as the more precious.

Tea caddy spoons are going to have their day now that the tea drinking season has set in. Anything now that refers to the afternoon tea table is of importance.

Silver shaving cups as amended are set in shallow cups. Into these the alcohol is poured and set on fire without the bother of a wick. The flames surround the sides of the center cup instead of being beneath.

The prettiest new trinket for a writing desk is a roller blotter modeled exactly after a park road roller, with the exception that the frame work effloresces over the blue tinted roll beneath, with a pretty color effect and the handle is a thing of beauty.

Silver pins are worthy all praise, so beautiful are they in design. There are graceful flower shapes in beaten silver. There are flouriations purely ornamental of beautiful workmanship. There are round oxidized brooches, and others in dull silver in which turquoises are set or imitation stones in colored enamels.

The newest rings have their settings formed by the ring proper, whose ends, if one may speak thus, are twisted into interesting shapes inlaid with stones and enclosing some larger gem of a different color. These settings are sometimes extended to almost reach the knuckle, and exclude the possibility of wearing another ring.

The beasties are still in force and the insects are in the air. A spider is one of the newest. He is of the venomous species, but all the same is a fine example of skill in enamels. The butterflies with enamel bodies, the wings of slender gold ribs stained with a couple of stones or bits of enamel, are beautiful examples of later insect jewelry.

ELSIE BEE.

Elmer Starr, jeweler, Valpo, Ind., will open a jewelry store in Hobart, Ind.

# Diamonds

.. AND ..

# Diamond Jewelry

.. FOR THE ..

## HOLIDAYS.

We have an unusually large stock of mounted goods all set in the latest designs of mountings and at prices that cannot be beaten.

We have imported a large reserve stock of Diamonds, and will not advance any of our prices at present. Dealers making their selections now will have the full advantage of the low tariff prevailing on Diamonds before the Wilson Bill went into effect.

You can save 15 per cent. by buying your Holiday Stock now.

If inconvenient to call upon us, or if you have a call for some special article not in your stock, let us send you a selection package.

## Cross & Beguelin

Loose—DIAMONDS—Mounted.

17 Maiden Lane,  
New York.

43 RUE MESLAY, PARIS.

## A. J. HEDGES & CO.,

MANUFACTURERS OF

Gold, Variegated and Enameled Jewelry.

BLACK AND WHITE ENAMELED GOODS

— A SPECIALTY. —

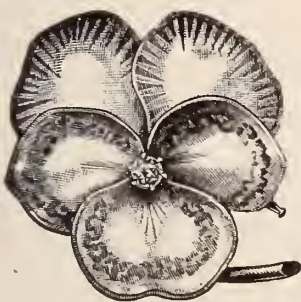

SIDE COMBS AND COLLARETTES, LACE PINS, SCARF PINS, BROOCHES AND PENDANTS, CHATELAINES AND BRACELETS, LINK BUTTONS AND STUDS, LADIES' AND GENTLEMEN'S GOLD AND SILVER GARTERS.

FACTORY:

90 Mechanic St., Newark, N. J.

6 Maiden Lane, New York.

# MUSICAL BOXES

FACTORY AT AUBERSON, SWITZERLAND.  
ESTABLISHED 1828.

E. L. CUENDET, 21 John Street, New York City.

Send for our New Illustrated Catalogue for 1894, containing Full Particulars and Price Lists.

# A MODEL FACTORY BUILDING.

THE KENT & STANLEY CO.'S MAMMOTH NEW STRUCTURE, THE FINEST OF ITS KIND IN THE WORLD.

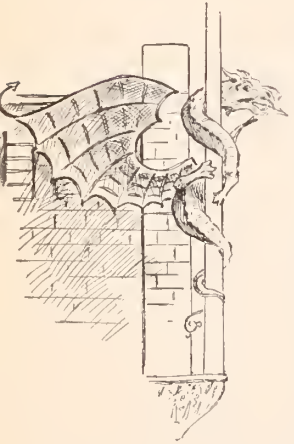

**P**ROMINENT among the many handsome factory buildings for which Providence is noted is the handsome structure built and occupied by the Kent & Stanley Co., on the Square bounded by Sabin, Aborn, Beverly and Mason Sts., in that

city. The property which it occupies was the location of the old-time popular skating rink, destroyed by fire last year. Mr. Edwin F. Kent, recognizing the advantages of the site, on his own responsibility purchased the property after the fire, though at that time the building occupied by the Kent & Stanley Co., at Eddy and Fountain Sts., was generally looked upon as a model factory, excellently planned and perfectly equipped.

Mr. Kent's foresight in the matter of the purchase of the new site was soon endorsed by his partners. Its proximity to the new railroad depot, which will be one of, if indeed not the finest, in the country is a guarantee of increasing values in that section of the city, while the increased shop room was something rendered imperative by the firm's constantly increasing business.

Work on the new structure which is depicted in one of the illustrations in this article, was begun on November 1, 1893, and October 1, 1894, the company was operating in its new quarters.

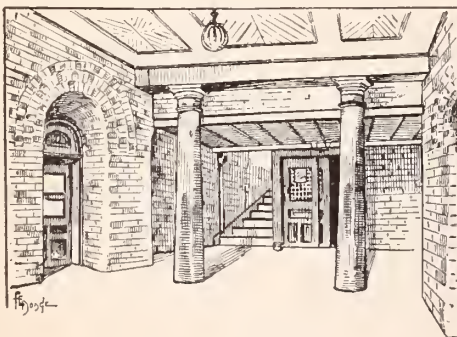

MAIN ENTRANCE ON SABIN ST.

The readers of the CIRCULAR can gather an idea of the immensity of the structure when it is borne in mind that it occupies an

acre of ground, rises seven stories above the foundation, has over 250,000 square feet of floor space, about 1,200 windows and required over five million bricks in its construction. While nearly all available space has already been leased, firms seeking modern quarters will do well to bear in mind that rentals are figured on a basis of 30 cents per square foot per annum, including power, steam heat water and elevator service.

The ground plan and character of the plot is excellently suited for the purpose to which it has been put. The L shaped formation gives it a frontage of 276 feet on Mason St., 221 feet on Aborn St., 106 feet on Sabin St., and 123 feet on Beverly St. A light well 40x200 feet extends from roof to basement in the main structure



THE KENT & STANLEY CO.'S BUILDING.

which with the additional advantage of four street frontages makes that great desideratum, good light, an assured fact for each tenant.

Red brick with brownstone trimmings was the material used for the walls, which rest on particularly solid foundations. At either corner on the Sabin St. facade are two handsome flag staffs held in place by artistic creations in wrought iron of dragons, one of which is incorporated in the initial letter beginning this article. Flags floating from these staffs bear, one, the company's trade mark on a white field and the other the national colors.

The two entrances to the building are well worthy of attention. Each shows a granite arch, while within enameled bricks of a light bluff tint please the eye and present an imperishable surface.

## THE KENT & STANLEY CO.

Our illustration shows the Sabin St. entrance with the handsome wrought iron elevator in the back ground, and two beautifully silvered supporting columns. The other entrance on Beverly St. is practically the same. Marble slabs for the names of the tenants is another feature not usually found in a factory building, and rapid running passenger elevators at either entrance afford quick access to, or egress from any floor. In the driveway running through from Sabin to Mason Sts., are two commodious freight elevators.

Floorings throughout are of maple, each floor being nearly an acre in area. The supporting columns are of iron, rising thirteen feet to the ceilings. Grinnell sprinklers and all other modern factory conveniences make the building a perfect one, whether from the view of the tenant, the insurance or the factory inspectors. Over 3 500 hands can find accommodation within its walls. Power and light are furnished by the company's private electric plant, one of the finest in the country.

The offices of the Kent & Stanley Co. are fitted up in oak, in the best taste, and pre-

sent an exceedingly attractive and handsome appearance. They occupy practically the whole of the Sabin St. wing on the sixth floor. Our illustration shows a view of the general office; adjoining it is the private office of Mr. E. F. Kent, which also connects with the director's suite.

The Kent & Stanley Co.'s shop, ever known as a model one, is in the new building better than ever. In one of the illustrations accompanying this article is shown a corner in the silver shop, a line in which the company is winning rapid recognition, and of which some of the productions, notably yachting trophies, have already been the subject of extended mention in the CIRCULAR.

A pioneer in selling its goods directly to the retail trade, the company, through its ten traveling salesmen and New York, Boston, Philadelphia and San Francisco offices offers a wide and varied line of goods. Some idea of its scope can be gathered from the fact that among them are:

**THE KENT & STANLEY CO.**

One-tenth and one-quarter Gold Seamless Wire Chains; Gents' Rolled Plate Vests, all Seamless Wire, 1, 2, 3, Strand Curbs; Dickens, Trace, Rope, Single Curb, Boston

**THE KENT & STANLEY CO.**

its predecessor, if that is possible. The business of the present Kent & Stanley Co. was first established in 1873 under the style of William H. Robinson & Co.,

**THE KENT & STANLEY CO.**

surviving partners, Edwin F. Kent and Arthur W. Stanley, under the old firm name. In 1887 these gentlemen purchased Mrs. Robinson's interest and continued under the style of Kent & Stanley. Under the new impetus, business during the two following years was doubled, but on Feb. 19, 1888, another fire once more interrupted operations by burning the factory entirely to the ground. Another shop was immediately found by Mr. Kent, and by noon of the day following the fire new machinery was already being put in position at the new shop, an instance of his indomitable will and prompt action in an emergency to which is due in a large measure the firm's success and high position to-day.

A lease of the ground on which the burned building had stood was quickly secured, and without the least unnecessary delay, Kent & Stanley began the erection of a building suitable to the needs of jewelry manufacturers which, when completed, ranked among the best factory buildings in the city. The firm took up its quarters in it and continued with increasing success. In February 1891, it was incorporated, under the title of the Kent & Stanley Co., being capitalized at \$300,000, represented in real property, and with charter rights for half a million. In November, 1893, the constantly increasing business necessitated larger quarters and the balance of the treasury stock was issued. In July, 1894, this additional stock had been issued, paid for in cash and invested in the new plant, which forms the subject of this article. It represents an investment of about \$350,000, and the total capital and surplus of the company in-



VIEW OF GENERAL OFFICE.

and Fancy Links; Red Gold and Platinum Links in all styles; Ladies' Lorgnette, Neck, Vest and Victoria Chains; 1,500 styles Gold, Silver and Plated Locketts and charms; White Stone Lace Pins and Brooches; Hair Ornaments; Chain Bracelets, Plate and Sterling Silver; Hat, Hair, Stick, Scarf and Bib Pins; Plated Sword Corsage Pins; Bracelet and Eye-Glass Chains.

In Sterling Silver Novelties, all warranted Sterling Silver are: Garters, Collarettes, Pocket Combs. Tie Holders; Belts with Silver, Pearl and Tortoise Shell Buckles, Paper Cutters and Weights, Match and Stamp Boxes, Trays, Letter Clips, Letter Openers, Book Marks, Prayer Book Marks, Thermometers and Calendars, Satchel Tags, Hat Marks, Coat Hangers, Souvenir Spoons, Umbrella Clasps, Pearl Teething Rings and Rattles, Glove Hooks, Button Hooks, Glove Stretchers, and Hat Buckles, Hair Pins in Celluloid, Real Tortoise Shell, Silver Mounted; Tooth Brushes, Shoe Horns and Letter Seals, Mirrors, Game Counters, Cigarette Cases, Sword Corsage Pins, Key Ring Chains, Bonbon Spoons, Pocket Knives, Scissors, Razors, Manicure Articles, Gold and Silver Mounted Suspenders, Novelties in Leather Card Cases, Memorandum Books, etc.; Stag Handle Cutlery Novelties, Corkscrews and many others.

The company issued last year one of the finest illustrated catalogues ever put out by a jewelry house and another is now in preparation which will be even better than

at 25 Calendar St. and the output consisted of chains. In 1882 Mr. Edwin F. Kent became a member of the firm and at once took an active interest in its welfare. In 1884 occurred the disastrous fire still remembered by the citizens of Providence, in

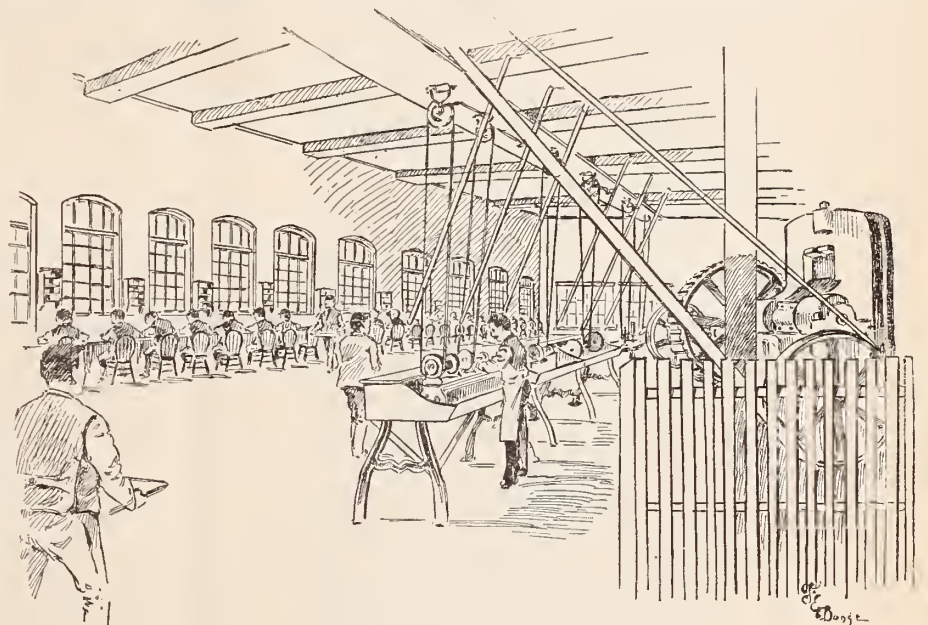

A CORNER IN THE SILVER SHOP.

which the factory was destroyed. New quarters were found at 7 Eddy St., and operations were again resumed. In 1885 Mr. Robinson died, and for nearly two years the business was conducted by the

vested in business is \$650,000. Its officers are: president, A. W. Stanley; treasurer, E. F. Kent; vice-president, J. S. Ingalls; secretary, J. D. Warren. George R. Clarke is superintendent and designer.

## SILVER STAMPING LEGISLATION AMONG THE STATES.

## JEWELERS THROUGHOUT THE COUNTRY PUSHING THE CIRCULAR'S COMMON BILL.

The jewelers throughout the country selected by THE CIRCULAR to exercise their influence to have introduced into the legislature of their respective State, a common measure designed to regulate the stamping of silver wares are acting their part in a most laudable manner as may be inferred by a perusal of the appended letters, which were received in answer to a communication of THE CIRCULAR of which the following is a copy:

Gentlemen:

You will recollect our sending you some time ago, a draft of a legislative measure dealing with the stamping of silver manufactures.

Please let us know what progress has been made in the matter of obtaining stamping legislation.

An immediate reply will be appreciated by

Yours truly,

The Jewelers' Circular Publishing Co.

The bill of which drafts were sent to these jewelers is as follows:

SECTION 1. A person who makes or sells or offers to sell or dispose of, or has in his possession with intent to dispose of, any article of merchandise marked, stamped or branded with the words "sterling" or "sterling silver" or encased or enclosed in any box, package, cover or wrapper, or other thing in or by which the said article is packed, enclosed or otherwise prepared for sale or disposition, having thereon any engraving or printed label, stamp, imprint, mark or trademark, indicating or denoting by such marking, stamping, branding, engraving or printing that such article is silver, sterling silver or solid silver, unless nine hundred and twenty-five one-thousandths of the component parts of the metal of which the said article is manufactured are pure silver, shall be deemed guilty of a misdemeanor.

SECTION 2. A person who makes or sells or offers to sell or dispose of, or has in his possession, with intent to sell or dispose of, any article of merchandise marked, stamped or branded with the words "coin" or "coin silver," or enclosed in any box, package, cover or wrapper, or other thing in or by which the said article is packed, enclosed or otherwise prepared for sale or disposition, having thereon any engraving or printed label, stamp, imprint, "mark" or "trademark" indicating or denoting by such marking, stamping, branding, engraving or printing that such article is "coin" or "coin silver," unless nine hundred one-thousandths of the component parts of the metal of which the said article is manufactured are pure silver, shall be deemed guilty of a misdemeanor.

SECTION 3. Whoever violates the provisions of either of the preceding sections shall, upon conviction be subject to a fine not exceeding one hundred dollars for each offence or be imprisoned in the county jail not more than thirty days.

SECTION 4. This Act shall take effect upon its passage.

THE BILL WILL BE PRESENTED TO THE NEBRASKA LEGISLATURE.

OMAHA, Neb., Dec. 14, 1894.

Jewelers' Circular Pub. Co.:

GENTLEMEN:—Replying to yours of the 6th, would say that, I received, some time

ago, draft of a legislative nature dealing with stamping silver manufactures, and I have already received the signatures of all the leading jewelers in this city, and when our Legislature meets next month I shall see that it is brought before the body, and will later on let you know the outcome of the petition. I realize that something like this must be done nationally, in either gold or silver, or the better class of trade might as well throw up their hands.

Yours truly,

C. S. RAYMOND.

SOUTH CAROLINA SOLONS CONSIDERING THE BILL.

CHARLESTON, Dec. 8, 1894.

Jewelers' Circular Pub. Co.:

DEAR SIR:—In reply to your letter of the 6th, the matter has been introduced as directed. Will let you hear more about it when we find out what disposition our Solons will make of it.

Yours truly,

JAMES ALLAN & Co.

THE BILL TO BE PRESENTED TO THE MAINE LEGISLATURE.

PORTLAND, Me., Dec. 8, 1894.

Jewelers' Circular Publishing Co.:

DEAR SIR:—In reply to your favor of the 6th inst., would say that our Legislature does not meet until January. We will have the measure presented through one of our representatives, and think that there will be no doubt of its going through.

Yours truly,

WM. SENTER & Co.

OBSTRUCTIVE MEASURES IN THE GEORGIA LEGISLATURE.

ATLANTA, Ga., Dec. 9, 1894.

Jewelers' Circular Publishing Co.:

GENTLEMEN:—In reference to your letter of the 6th inst., will say that we have pushed the matter constantly before our Legislature during this present sitting, and it has been postponed so that it will be impossible to have it acted upon until next meeting of that body, which takes place 10 months hence.

The Legislature adjourns now in a few days, and although we have watched the matter carefully, and had an attorney on the spot *all the time*, it was impossible to get the matter before them this session on account of obstructive measures which the present session has been laboring with.

The members of the Atlanta Jewelers' Association are a unit in favor of the passing of the law as we believe it will curtail the work of department stores

against us. There are four immense stores of this kind here, and they are carrying stocks of watches, solid silver, cut glass, and fancy goods, and in some lines larger stocks than the largest jewelry stores carry.

We think that this kind of competition is now the greatest menace against the jewelry trade.

Yours truly,

J. P. STEVENS & BRO.

CONNECTICUT JEWELERS WILL PUSH THE BILL.

NEW HAVEN, Conn., Dec. 7.

The Jewelers' Circular Publishing Co.:

GENTLEMEN:—Replying to yours of Dec. 6th in reference to draft of Legislature and measure dealing with the stamping of silver ware, we report the following progress. We have amended section 3 to read \$500 instead of \$300 and imprisonment, one half of the fine imposed to go to the informer; we have about one dozen signatures. It will be presented at the next meeting of the State Association of Retail Jewelers, of which there are fifty in the organization. Mr. F. L. Tibbals, secretary and treasurer, of this company, is a member of our State Legislature, which convenes on Jan. 1st, '95. He will take charge of the measure in our State. As a whole we think you can be assured that the matter is receiving attention that *will* be "attention."

Very truly yours,

THE GEORGE H. FORD CO.

INTEREST IN THE BILL IN MISSOURI.

ST. LOUIS, Mo., Dec. 10, 1894.

Jewelers' Circular Pub. Co.:

GENTLEMEN—Replying to your favor of the 6th inst. would say that our Legislature does not meet until next year.

Yours truly,

MERMOD & JACCARD JEWELRY CO.

In a previous communication, the Mermod & Jaccard Jewelry Co. expressed themselves in reference to the measure as follows:

ST. LOUIS, Oct. 4, 1894.

The Jewelers' Circular,

GENTLEMEN—Replying to your favor enclosing draft of bill to be presented to the Missouri Legislature, would say that we will take great pleasure in seeing that it is properly placed before the Legislature when it meets, which will be in January, 1895, and as the object is so commendable, we have little doubt but that it will be passed.

Thanking you for the interest you have manifested in this matter so important to the trade, we are,

Yours truly,

MERMOD & JACCARD JEWELRY CO.

# ★ ROGERS & BRO., A I.

## ORANGE SEASON....

### ORANGE KNIVES.



Pearl, Ivoride or Plated Handles,  
Cutting Edge, Saw Back Blades.  
*(A feature first introduced by us), making*  
a good all round Fruit Knife.

### ORANGE SPOONS.

- FLEMISH
- COLUMBIA
- SAVOY
- TUXEDO
- HARVARD
- YALE
- PRINCETON
- STOCKBRIDGE
- FLORIDA
- SHELL

PATTERNS.

Put up in sets of 6 in Plush Lined Boxes.

### ORANGE SETS.

1 Knife and 1 Spoon, or  
6 Knives and 6 Spoons.  
Put up in Plush Lined Boxes.

### ORANGE PEELERS.

..... POCKET OR TABLE SIZES.

### ORANGE HOLDERS.

Also a Large Line of Fancy Pieces put up in Beautiful  
Plush Lined Boxes. Suitable for the Holiday Trade.

FLEMISH ORANGE SET, No. 5.

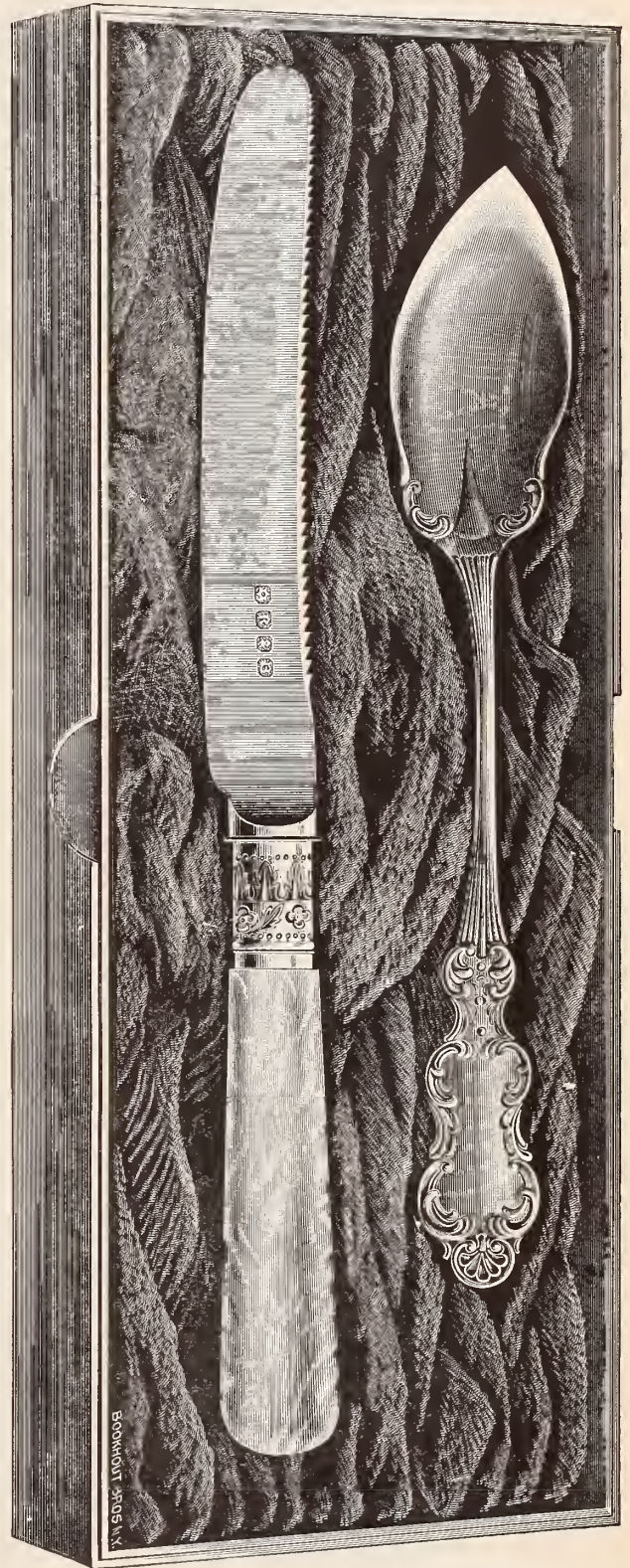

# ROGERS & BROTHER,

16 Cortlandt St., New York.  
WATERBURY, CONN.

THE OLDEST MANUFACTURERS OF ROGERS' GOODS IN EXISTENCE.

ENTIRELY NEW CLOAK CLASPS.

ALL SIZES.

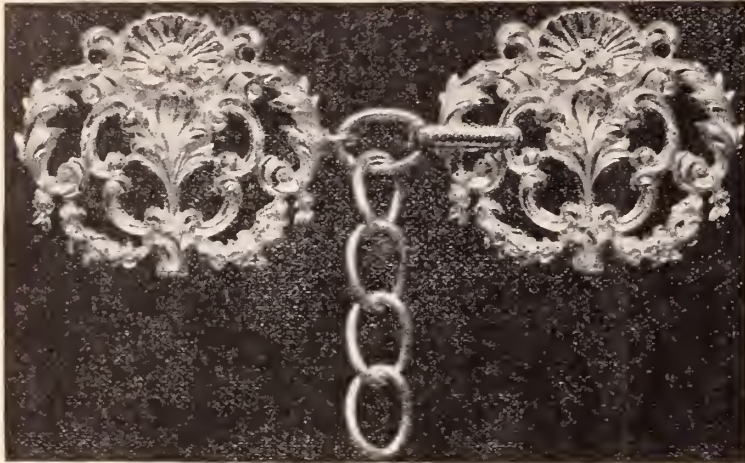

ALL PRICES.

MADE IN HEAVY STERLING SILVER IN MANY DESIGNS.

J. N. PROVENZANO, MANUFACTURER OF RICH JEWELRY AND SILVER NOVELTIES.  
39 UNION SQUARE, NEW YORK.



THE LATEST NOVELTY  
IN  
BIBLE BOOK-MARKS.

MOUNTED WITH  
Sterling Silver or Gold Ornaments,  
ON ALL SILK RIBBONS, 8 1-2 INCHES LONG  
WITH APPROPRIATE QUOTATIONS  
**WOVEN IN THE SILK.**

Nine different quotations. Ribbons in the following colors: Purple, black, white and lilac. Can be sold profitably at a popular price. Made only by

**STONE BROTHERS,**  
535 Broadway, NEW YORK.

FLAT WARE AND  
HOLLOW WARE  
STAMPED



IS THE GENUINE.  
Manufactured by  
**WM. ROGERS M'F'G CO.,**  
HARTFORD CONN.

PRESCRIPTION WORK.  
**QUEEN & CO.,**  
1010 Chestnut Street, PHILADELPHIA.  
SEND FOR PRICE-LIST AND ORDER FORMS.

BILL TO BE PUSHED THROUGH IN INDIANA.

INDIANAPOLIS, Ind., Dec. 8.

*Jewelers' Circular Pub. Co.:*

Our Legislature meets Jan. 8, 1895. We have mislaid the draft of bill sent us; please send another and we will use our best endeavor to have it carried through.

J. C. WALK & SON.

KENTUCKY JEWELERS ENDORSE THE BILL AND WILL PUSH IT.

LOUISVILLE, Ky., Dec. 10, 1894.

*The Jewelers' Circular Pub. Co.:*

GENTLEMEN:—Your letter of the 6th to hand in reference to the stamping of silver manufactures. Our Legislature does not meet until the Fall of '96, but in the meantime there will be new legislators elected, and as soon as we find out who our man is we will make it known to him and have him push the matter as much as possible. Trusting this will be satisfactory, we remain

Yours truly,

WM. KENDRICK'S SONS.

Wm. Kendrick's Sons had previously written THE CIRCULAR as follows:

*The Jewelers' Circular Pub. Co.:*

Your circular letter of 30th to hand. We had expected our Mr. W. C. Kendrick back by this time, but as he will not return for some little while yet, we write you that our Legislature will not meet for fully a year yet, but we will notify the other jewelers in the State and get them to apply to their different jewelers in reference to the matter and have it attended to, and press the matter as much as we can.

Yours truly,

WM. KENDRICK'S SONS.

THE LOUISIANA SESSION A YEAR OFF.

NEW ORLEANS, Dec. 10, 1894.

*Jewelers' Circular Publishing Co.:*

GENTLEMEN—Our Legislature doesn't meet till one year from next May. They meet only once every two years. This in reply to your favor 6th inst.,

Respectfully,

A. B. GRISWOLD & Co.

**A Gold Dust Swindler to be Tried.**

ALBANY, N. Y., Dec. 13.—Gov. Flower has granted the application of the governor of Maryland for requisition of Nathan Smith, the alleged gold-dust swindler of Baltimore, arrested in Cohoes, on the charge of conspiracy with intent to defraud.

Smith had opened a pawnshop in Cohoes, where he resided with his wife and six children. Detective Pumphrey traced him from Baltimore to Philadelphia, to Pittsburgh, to New York, to Albany, and thence to Cohoes. Smith's only defense was that he had been arrested without the process of law prescribed by the laws of the State of New York, without even the warrant of the governor or a police magistrate.



### Dull Outlook for the Creditors of J. L. Salomon & Co.

SAN FRANCISCO, Cal., Dec. 6.—The creditors of the bankrupt firm of J. L. Salomon & Co., consisting of Jacob L. Salomon and Adolph Mendelsen, proprietors of the Lombard Loan Co., 622 Kearney St., will not receive more than 20 cents on the dollar.

The failure might have been averted until after the holidays had not a disagreement between the partners resulted in Mendelsen taking steps to dissolve the partnership. It appears that for some time past the firm have been in urgent need of capital, to secure which they borrowed heavy sums and pledged jewelry consigned to them by eastern houses. For these loans they paid 1½ and 2 per cent. per month interest, requiring \$500 to \$600 a month. It is also hinted that Salomon speculated in stocks in hopes of bettering his condition.

Goodman Bros., New York, are the largest creditors, their claim amounting to \$26,367.96; it is said that in the past 15 years Salomon & Co. have purchased more than \$200,000 worth of jewelry from this house alone.

The assets in the store amount to \$13,953.55; unsecured debts \$52,000; secured indebtedness \$36,000, representing about \$50,000 worth of pledged jewelry.

Charges of fraud were made Dec. 4 at the meeting of creditors of the firm. The committee which examined the accounts consisted of Joseph M. Rothschild, Henry C. Dibble and J. Newman. It is said that unless Salomon & Co. agree to settle with their creditors on a satisfactory basis they will be prosecuted. The committee found that all the cash books for the years preceding 1894 had been destroyed. These books were needed to trace some of the accounts which aroused the suspicion of the committee.

### The Alleged Larceny Cases Brought by Samuel Kirk & Son.

BALTIMORE, Md., Dec. 13.—The last of the cases growing out of the alleged larceny of silverware from Samuel Kirk & Son were

assigned for trial in the Criminal Court Monday. Louis Falkenstein, charged with stealing a dozen silver tablespoons and a dozen silver teaspoons, was tried before Judge Harlan without a jury and acquitted.

The trial of Marcus Korman, charged with receiving articles stolen from Kirk & Son, was commenced. Ex-Governor Whyte is assisting in the prosecution of the cases.

### Secretary Roe, of F. G. Smith, Sons, & Co., Tells His Side of the Story.

DETROIT, Mich. Dec. 14.—On Nov. 21, 1894, Charles Roe, formerly secretary for the defunct firm of F. G. Smith, Sons & Co., was arrested on a *capias* by Herbert E. Boynton, assignee of the firm. F. G. Smith charged him with taking about \$5,000 worth of diamonds, sapphires, and watches out of the business and charging them to himself. Mr. Roe gave \$7,000 bonds for his release from custody.

Last week Mr. Roe filed a bill in the Circuit Court for an accounting. He asserts that in 1889 he arranged with George F. Smith to carry on the jewelry business, and the entire business of M. S. Smith & Co. was turned over to them. At that time Mr. Roe was owner of \$9,000 in shares of stock valued at \$12,000, and the good will of M. S. Smith & Co. was valued at \$50,000. He says he signed the articles of association of F. G. Smith, Sons & Co., without noticing how many shares had been credited to him and at various times signed, as secretary of the company, documents the contents of which he was in ignorance. No cash was paid into the new concern, the merchandise and good will being turned over instead. No attempt, he says, was made to do business under the articles. No stock certificates were issued and the business was conducted as a partnership rather than as a stock concern.

Mr. Roe makes F. G. Smith, F. G. Smith, Jr. and M. S. Smith, defendants, and alleges that each of them took money out of the business without his consent or knowledge,

and that they now owe the firm largely over and above a reasonable allowance for their services. He says that F. G. Smith Sr., took trips to Paris with his wife and charged the expense up to the firm besides withdrawing \$100 per week for his services without the understanding of his associates. The bill also states that Mr. Roe signed a paper the contents of which he did not know, but which turned out to be a chattel mortgage on the stock to Robert Howard, as trustee for a large number of creditors. If an accounting was made Mr. Roe claims that the defendants will be found to be indebted to the firm to the amount of \$10,000. He says he has been systematically frozen out and asks relief from the court.

A representative of THE CIRCULAR called upon the firm and F. G. Smith, Jr., made the following statement: "All goods taken by members of the firm have been charged up to their personal accounts, and if not paid are assets of the firm and bills receivable. No one will deny that purchasing agents should have their legitimate expenses paid. We charged them to general expenses and they are paid out of general profits. These expenses were obligations of the firm instead of the individual. As to the allegation that Mr. Roe did not know what he was signing: At the time the document was made out Mr. Roe placed his name to it and handed it to the trustee, with the remark that it was all in his hands now. We are perfectly willing that our books should be investigated and we shall make no objection to an examination of them."

David Neff, jeweler, Royal Center, Ind., has brought out against the Pittsburgh Cleveland, Cincinnati & St. Louis Railroad Co. for \$5,000 damages. He alleges that a conductor threw him off a train one night recently in the midst of a dense wood and many miles from home. His ticket was not good on that particular train, but he claimed to have tendered his fare to the next stop.

## DON'T LET A GOOD THING ESCAPE YOU.

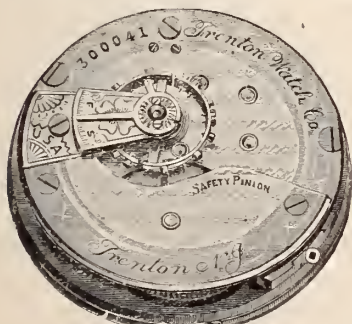

18 SIZE, 7 JEWELS.

THE REDUCED PRICE ON ALL GRADES OF TRENTON MOVEMENTS PLACES THEM WITHIN REACH OF EVERYBODY AND SURPASSES ALL COMPETITION. THEIR EVER INCREASING POPULARITY IS DUE TO THE UNIVERSAL SATISFACTION THEY ARE GIVING. THOUGH LOW IN PRICE, THEY ARE HIGH IN QUALITY.

SEND FOR ILLUSTRATED PRICE LIST,  
AND ORDER FROM YOUR JOBBER.



16 SIZE, 16 JEWELS.

# TRENTON WATCH CO.,

TRENTON, N. J.

**The Osaka Watch Mfg. Co. of Japan.**

SAN DIEGO, Cal., Dec. 12.—A. H. Butler just returned to San Diego, from Japan where he has been engaged in establishing the Osaka Watch Mfg. Co., says that buildings for the factory are now being erected and he shall go back there in a short time to put the works in operation.

All the foremen of the establishment will be Americans but the 500 or more workmen will be Japanese. J. D. Hanbury who is interested in this enterprise now has an importing agency in Yokahama.

**The Assets and Liabilities of Eugene B. Schiller.**

The inventory and schedules of Eugene B. Schiller, jeweler, 415 Broadway, New York, who assigned Nov. 22d to Aaron Morris, were filed in the Court of Common Pleas, Wednesday last. They show the liabilities to be \$10,008.67, the nominal value of the assets \$6,445.80, and the actual value of the same, \$2,163.39. The assets consist of merchandise nominally worth \$4,104.74, whose actual value is given as \$1,495.83 and nominal book accounts \$2,341.06, actually worth \$667.54. But \$1,000 of the liabilities is for borrowed money, this amount being due to Levy & Radane, 10 Walker St., New York. The remainder is for merchandise sold.

Among the principal merchandise creditors are: M. W. Carr & Co., \$230; The H.

Ludwig Co., \$155; Geo. H. Caboone & Co., \$125; Chas. W. Lord, \$255; Sadler Bros., \$353; H. Wexel & Co., \$188; Wm. H. Wilmarth Co., \$115; Daggett & Clap, \$186; Geo. H. Holmes & Co., \$125; B. K. Smith & Co., \$168; W. E. Webster & Co., \$172; F. W. Weaver & Co., \$190; E. S. McLaughlin & Co., \$140; Stanley Bros., \$227; D. R. Childs & Co., \$172; E. Brown & Co., \$210; C. H. Gilchrist & Co., \$225; S. P. Orth & Co., \$107; Bugbee & Niles, \$107; Cutler & Lull, \$171; Foster & Bailey, \$149; Gladding & Coombs Bros., \$218; S. & B. Lederer, \$349; Marden & Kettlety, \$239; T. Quayle & Co., \$189; Thornton Bros., \$120; B. A. Ballou & Co., \$167; Waite, Thresher Co., \$149; Young & Stern, \$206; Greene & Knox Mfg. Co., \$238; Hancock, Becker & Co., \$224; J. T. Inman & Co., \$202; Nester & Co., \$134; Payton & Kelley, \$172; Whitestone Jewelry Co., \$156; Wildprett & Saacke, \$334; Wightman & Hough Co., \$152; Blake & Clafin, \$141; J. Fleishner, \$105; E. B. Gilmore & Co., \$189; Chas. Keller & Co., \$147, and Stern Bros. & Co., \$100.

**Masked Burglars Gag and Rob Jeweler Edward Coville.**

Du Bois, Pa., Dec. 12.—Two masked burglars entered the jewelry store of Edward Coville, Brockwayville, Monday evening before closing time, and after beating and gagging the store-keeper, took \$50 in

money, which they found in the drawer, and a gold watch from the show-case. Before they could get any more of the jewelry some parties entered the store and tried to capture them. The robbers escaped through the door with revolvers drawn.

Mr. Coville was not seriously hurt.

**A Company Incorporated to Make Silversmiths' Supplies.**

PATERSON, N. J., Dec. 15.—The certificate of incorporation of the Foot & Brooks Co. has been filed with the county clerk. The incorporators of the company are: James D. Foot, New Rochelle, N. Y.; Charles F. Dayton, New Market, N. J.; and Stephen H. Brooks, John L. Brooks, and Sandford D. Foot, all of New York.

The company purpose to engage in the manufacture of polishing materials and silversmiths' supplies, in this city. The authorized capital of the company is \$25,000 and they will begin with \$2,000 paid in, which is divided into 20 shares of \$100 each, and all held by the persons above mentioned.

The jewelry store of James M. Reynolds, Cohocton, N. Y., has been closed on a chattel mortgage in favor of Hon. Frank Campbell, cashier of the Farmers' and Mechanics' Bank, of Bath. This is an outcome of the failure of the Cohocton Valley Cigar Co.

# THE SOUL OF THE DIAMOND.

A PASTEL IN PROSE.

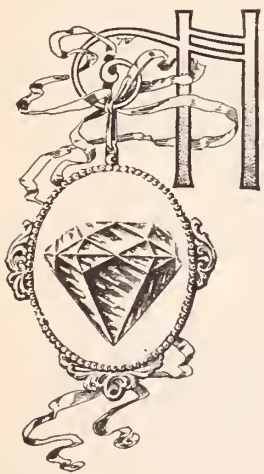
**I.**

HUNDREDS of uncounted years it lies hidden from eye of man, enclosed in the baser mould in the bosom of Mother Earth, little dreaming that within its soul resides the quintessence of brilliancy and purity, and that man prizes it above all things of material value.

**II.**

In the seeking for riches, after the prospector has discovered its lair, after organized labor has delved for it and unearthed it, from a nameless pebble it is a modicum of wealth, though in aspect but a dirty mite of quartz.

**III.**

Traveling over the main, thousands of miles, it reaches the works of **OPPENHEIMER BROS. & VEITH, NEW YORK**, whose cutters and polishers lend their art, bringing forth its true nature and making it "a gem of purest ray serene," the superlative of beauty, the zenith of purity, emblem of riches, token of innocence.



### Imports and Exports for October, 1894, and the Preceding Ten Months.

WASHINGTON, D. C., Dec. 15.—The summary statement of imports and exports for the month ending Oct. 31, 1894, and the ten months ending the same date, compared with the corresponding periods of 1893, has been issued, and contains the accompanying figures relative to the jewelry trade:

	OCTOBER		SEPT.	TEN MONTHS ENDING OCTOBER.	
	1894.	1893.	1894.	1894.	1893.
<b>IMPORTS.</b>					
Diamonds and other precious stones, rough and uncut, including glaziers' and engravers' diamonds, not set, and jewels to be used in the manufacture of watches.	\$5 780	\$66 879	\$5 785	\$818 033	\$732 596
Clocks and parts of.	45 146	22 449	34 283	111 711	152 095
Watches, and parts of, and watch materials and movements.	115 601	121 935	86 709	793 225	1 261 897
Jewelry, and manufactures of gold and silver.	64 733	65 489	25 030	318 655	630 469
Precious stones, n. e. s. and imitations of, not set.	523 626	471 304	124 709	5 719 789	9 587 308
<b>EXPORTS.</b>					
Clocks, and parts of.	85 88	71 717	78 537	732 628	760 403
Watches, and parts of.	32 426	54 996	28 735	255 099	326 668
Jewelry, and manufactures of gold and silver.	44 045	62 190	48 679	589 981	860 132
Plated ware.	27 732	32 342	17 051	199 220	279 845
<b>EXPORTS OF FOREIGN MERCHANDISE.</b>					
Diamonds and other precious stones, rough and uncut, etc.				2 220	355
Clocks, and parts of.			52	318	654
Watches, and parts of, etc.	14		18	48 452	437
Jewelry, and manufactures of gold and silver.	2 192	782	1 196	51 489	11 763
Precious Stones, n. e. s. and imitations of, not set.			2 096	4 264	1 168

### Changes in the Personnel of Larter, Elcox & Co.

Three new members will be admitted to the firm of Larter, Elcox & Co., 21 Maiden Lane, New York and Newark, N. J., on Jan. 1st. They are Wm. D. Elcox, now western traveler for the firm; Henry C. Larter, at present with Hayden W. Wheeler & Co., and Halsey M. Larter, who has been several years at the factory in Newark. Mr. Elcox who is the son of the late Henry E. Elcox, of this firm, will be transferred to the eastern territory formerly covered by his late father. Henry C. and Halsey M.

Larter are both sons of Frederick H. Larter, the senior member of the firm; the former will become a traveler for the concern while the latter will have direct charge of their factory in Newark.

As previously announced in THE CIRCULAR, on the same date Theo. M. Woodland and Wm. H. Jones will withdraw as members of the firm of Larter, Elcox & Co., and continue in Newark in the same line of

The action which was commenced about two years ago was on an alleged infringement by the Wilmot & Hobbs Mfg. Co., of a patent watch case insulator known as the "Ajax" owned by the Newark Watch Case Material Co. When the case come to trial about six months ago before the United States Circuit Court, in Connecticut, the bill of complaint was dismissed and the patent declared invalid. An appeal was then taken to the Circuit Court of Appeals, the court of final resort in patent cases, before whom it was argued last week. Decision was reserved.

### Wm. H. Atwater Charged With Retaining Money Due Another.

William H. Atwater, dealer in clocks, 10 Maiden Lane, New York, and living at 54 Clark St., Brooklyn, was arraigned in the Tombs Police Court, New York, Friday, on a charge of grand larceny preferred by Jas. McKeon, 44 Jackson St. Mr. Atwater was the representative of the firm of Fd. & Ch. Pierre, clock manufacturers, of Paris, France. He sold Hilton, Hughes & Co. goods to the amount of \$283.50 and the money was paid.

McKeon claimed that the money was retained by Atwater who should have turned it over to him as the representative of the Pierres. Mr. Atwater showed papers in court which appeared to justify him in holding the money. The case was adjourned until Jan. 8th, and Mr. Atwater was released in \$1,500 bail.

### The Heavier Creditors of J. L. Saloman & Co. Inclined to Accept their Offer.

SAN FRANCISCO, Cal., Dec. 12.—The heavier creditors are in favor of accepting the latest offer of J. L. Saloman & Co., viz.: a settlement on a basis of 25 per cent.—10 per cent. cash, balance in three equal notes, payable in three, six and nine months respectively.

H. H. Davis, attorney for the firm, states that the partners deny all the allegations of collusion and crookedness in the accounts. They intend, he says, to pay their creditors in full in time. The firm's petition in insolvency was prepared last week. According to schedule, the liabilities are \$88,858.47. Of this sum pledges of stock have secured \$36,000. The goods held by the secured creditors are not enumerated among the assets, which include the stock on hand valued at \$14,000, and the fixtures valued at \$1,500.

The schedule exempts from execution includes merely wearing apparel and household furniture, \$425 of which belongs to Mendelsen and \$500 to Saloman.

The Eagle Sterling Co., Glastonbury, Conn., were fully organized and articles of association subscribed to, the past week. The officers elected are: President, S. P. Turner; vice president and manager, E. S. Stevens; secretary, P. H. Goodrich; treasurer, S. C. Hardin.

business under the firm name of Jones & Woodland. Their manufacturing department will be under the direct supervision of W. C. Woodland, who has had over 30 years' experience with the old firm.

### The Watch Insulator Case Before the Court of Last Resort.

The suit of the Newark Watch Case Material Co., Newark, N. J., against the Wilmot & Hobbs Mfg. Co., Bridgeport, Conn., was argued on final appeal early last week, before the United States Circuit Court of Appeals, sitting in New York.

### Exports from Foreign Countries to the United States.

WASHINGTON, D. C., Dec. 15.—By a recent arrangement in the State Department, the Consuls-General in Canada, in Mexico, and in the various countries in Europe, transmit to the department, as soon as possible after the end of each quarter, consolidated statements showing the exports to the United States declared in their respective districts and in the consular districts subordinate to them.

The following are the declared exports of jewelry, precious stones, etc., from the different countries during the September quarter:

#### JEWELRY.

AUSTRIA-HUNGARY.—From Prague, \$371.49; Reichenberg, \$34,452.76. Total, \$34,824.25.

FRANCE.—From Paris, \$606,883. Total, \$606,883.

GERMANY.—From Mayence, \$58,991.63; Stuttgart, \$1,808.45. Total, \$61,800.08.

ITALY.—From Florence, \$583.60; Milan, \$617.60; Rome, \$260.74. Total, \$1,461.94.

#### DIAMONDS.

BELGIUM.—From Antwerp, \$56,204.91; Total, \$56,204.91.

NETHERLANDS.—From Amsterdam, \$862,060.69. Total, \$862,060.69.

PROVINCE OF ONTARIO.—From Toronto, \$84,621.43. Total, \$84,621.43.

#### OTHER PRECIOUS STONES.

CEYLON.—From Colombo, \$125. Total, \$125.  
MEXICO.—From Nogales, \$994; Nuevo Laredo, \$305; Paso del Norte, \$400; Nuevo Laredo, \$350. Total, \$2,049.

#### WATCHES, CLOCKS AND MATERIALS.

FRANCE.—From Lyons (including Dijon), \$7,025.54; Paris, \$46,962. Total, \$53,987.54.

GERMANY.—From Frankfort, \$2,429.53; Freiburg, \$4,331.60; Kehl, \$379.96; Munich, \$1,810.25; Stuttgart, \$1,010.81; Weimar, \$1,768.87. Total, \$11,731.02.

SWITZERLAND.—From Basle, \$195,230.75; Berne, \$107.12; Geneva, \$22,872.45. Total, \$218,210.32.

#### JEWELERS' SWEEPINGS.

PROVINCE OF ONTARIO.—From Toronto, \$3,960. Total, \$3,960.

PROVINCE OF QUEBEC.—From Montreal, \$1,550. Total, \$1,550.

### The Wm. Rogers Mfg. Co. Sue the R. W. Rogers Co.

HARTFORD, Conn., Dec. 15.—An injunction suit has been brought by the William Rogers Mfg. Co. against New York parties using the name of Rogers. The case is against the R. W. Rogers Co. The hearing on the injunction comes up before Judge Lacombe, in the United States Circuit Court, in New York next week Friday.

In 1883 R. W. Rogers went in with R. Strickland & Co., Albany, N. Y. Goods were made by Strickland, and the stamp of Rogers Silver Plate Co. put on. In that year the William Rogers Mfg. Co. secured a permanent injunction against Strickland.

### The Death of Herman E. Alderman.

NEW HAVEN, Conn., Dec. 16.—Herman E. Alderman, jeweler, 39-41 Church St., died very suddenly yesterday morning at his home on Sylvan Ave. Mr. Alderman was taken sick about 10 days ago with a hard cold which soon became pneumonia. His death was a great shock to his family, as they had every hope of his recovery.

Mr. Alderman was one of the best known of the middle-aged Germans of this city. He was born in Strasburg, 44 years ago, and came to this country with his parents when only two years of age. His parents settled in this city. The deceased leaves a widow and five children, Herman and Eugene, who assisted him in his business, and Nettie, Walter and Edith Alderman.

Mr. Alderman was a prominent Mason and a member of Connecticut Rock Lodge. He was also a prominent member of the Arion Singing Society and of the German Aid Society. In politics he was a Democrat. At an early age he learned the jeweler's trade with the late Frederick Porth, a prominent jeweler in his day, whose store was on Church St. Upon Mr. Porth's death, Mr. Alderman succeeded to the business and continued at that stand several years. About 20 years ago he removed to 39 Church St., and continued in business there ever since.

### Auer & Co., Louisville, Make an Assignment.

LOUISVILLE, Ky., Dec. 15.—Adam Atzinger, this week, filed an attachment suit against Henry Auer & Co., silver manufacturers, and a little later the firm assigned.

The Germania Trust Co. is the assignee. No schedule of assets and liabilities has been filed.

### The Jewelers' Security Alliance.

The regular monthly meeting of the executive committee of the Jewelers' Security Alliance was held at the Alliance office on Friday the 14th inst. There were present J. B. Bowden, vice president; H. H. Butts, chairman, N. H. White, and Geo. H. Hodenpyl, secretary.

The following were admitted to membership: Stephen Avery, 68 Nassau St., New York; David Clark, Easton, Pa. Crescent Watch Case Co., 103 State St., Chicago, Ill.; The Frank, Laubach & Nutt Co., Akron, O.; J. J. Hare, South Chester, Pa.; Clasen W. Hoyt, Stamford, Conn.; James M. Hoffer, Kane, Pa.; N. B. Levy & Bro., Scranton, Pa.; Geo. Phillips & Co., Scranton, Pa.; J. K. Laudermilch, Lebanon, Pa.; F. L. Parkhurst, Everett, Mass.; Seward D. Schenck, Binghamton, N. Y.

# THE BOWDEN SEAMLESS RING

IS MADE ONLY BY

## J. B. BOWDEN & Co.,

Makers of Finger Rings of every Description

REMOVED FROM BROADWAY AND JOHN STREET,

# TO 3 MAIDEN LANE,

NEW YORK.

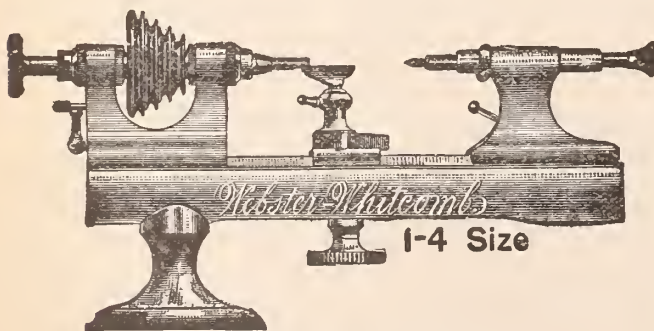

STRONGEST GUARANTEES.

Quality  
Maintained.  
Prices to  
Suit the Times.

Ask for our New  
Prices and  
Terms for 1894.

American Watch Tool Company,  
Chymistry Dist., Waltham, Mass.. Stoney Batter Works.

## ADVERTISING HINTS FOR RETAIL JEWELERS.

BY CHARLES AUSTIN BATES.

The Editor of THE JEWELERS' CIRCULAR has asked me to contribute a series of articles on retail jewelry advertising.

It is my desire to make these articles as useful as possible and to that end, an invitation is extended to retailers to send to me any of their advertisements which they would like to have criticised. It may be that there are some questions which they will care to ask and that I can answer.

Each week I will give several examples of advertising, which will illustrate my ideas on the subject. I do not present these advertisements with the claim that they are perfect, but only with the hope that they will contain some useful suggestion, and that some dealer at least will find that by making slight changes in them, as local conditions require, they will be able to make use of them, and so relieve themselves of one detail of their business

### PART IX.

**T**HERE is still one more week in which to reap the Christmas harvest. It is fortunate for a great many dealers that Christmas comes on Tuesday. It will have the effect of breaking up the trade to a certain extent. Instead of having one overcrowded, over-busy day on the twenty-fourth, there will be two days of more than ordinarily good business. Saturday is a big buying day, anyway, and a great many people will make their final Christmas purchases on that day. This will make the crowd less and easier to handle on Monday. It will also offer particularly good opportunities for advertising.

The Friday evening papers and those of Saturday morning should contain liberal advertisements of wide-awake dealers. They should do the same thing over again in the Sunday papers and those of Monday morning. Don't fill these advertisements too full, but make the story short and sweet and easily readable. The last two or three days before Christmas are busy days with everybody, and the man who wants to catch the eyes of buyers must speak up plainly and distinctly and must not be afraid to talk loudly. Just the same, he should not deal very much in generalities, but should make everything pointed and particular.

The best advertisement that I have seen lately in any line in any newspaper in America, is one of J. P. Stevens & Bro., published in the *Constitution*, Atlanta, Ga. It occupies two columns of space, and is just as good, if not better than a full-page ad. There is no possibility that anybody looking at the paper on that day would fail to see this advertisement.

I doubt if I can give an adequate description of it. Five-sixths of the space is taken up with a figure of a man in a dress suit with one arm extended upward, pointing to a little chunk of reading matter in the upper right-hand corner. The figure is in silhouette, and the contrast between the dead black and the surrounding white space is so forcible that it would be impossible to overlook the figure. The figure is just 17 inches high. The reading matter is  $3\frac{1}{4} \times 2\frac{1}{4}$  inches. There is nothing particularly startling about the reading matter, but it is very well written and tells what the ad. meant to tell. I think it is safe to say that there is not a single reader of

the *Constitution* of Dec. 8th, who does not know that Stevens & Bro. have refitted their store and that they are now ready for business.

I have a letter from Louis Burnett & Co., St. Joseph, Mo., which should have been answered before. They inquire whether or not it is profitable to advertise with circulars or letters, saying that they have two or three hundred customers whom they think of reaching in this way.

It is undoubtedly wise to send out a circular of some sort to those who have previously been customers. I do not think personal letters, or circulars in imitation of letters, are so good as the printed circular or a little booklet. These may be as elaborate as you choose or it may be merely a simple postal card. I do not believe that circular advertising for a new business is very likely to be profitable. The newspaper is the best developer of new business. The circular should be used only as an auxiliary.

I have had occasion to commend Burnett & Co. for the apparent honesty and earnestness of their advertising. Here is another example of it:

### IS THIS Plain Enough ?



If you buy anything at our store and it is not exactly what it should be or what it was represented to be—if you are not satisfied, bring it back, and we'll refund full price. If you find you could have bought the same thing any place else, at the same time, for less money, come in and we will give you a rebate equal to the difference. We will protect our customers in every way and will consider it a favor if you will report any dissatisfaction.

It is rather a strange coincidence that this particular advertisement should have been written by myself for a Washington, D. C., furniture house considerably more than a year ago. Since then, I have seen it floating around the country in all sorts of papers and used for all sorts of business. It seems that business men are perfectly willing to guarantee their goods, but they want somebody to help them to put the guarantee into words. I do not see how the statement "Money back for unsatis-

factory goods" could be made any plainer than it is made in this ad.

Here are two advertisements published by the Jarck Optical Co., Brooklyn. They

### THERE IS SUCH A THING

As wearing glasses when you shouldn't and not wearing them when you should. It's a mistake to do either. When you are in doubt we would request you to call on us to have your Eyes carefully attended to. It costs you nothing to talk the matter over with us and you may avoid serious trouble resulting from wrongly adjusted glasses.

We prescribe no glasses where none are needed, and if you do need them we sell a much finer quality at a much lower price than you can purchase elsewhere.

### The Jarck Optical Co.,

J. E. O. JARCK, Attending Optician,

473 Fulton St., Near Lawrence.

### JARCK.

This name stamped upon or in any way connected with Spectacles and Eyeglasses is a guarantee of superior quality and perfect fitting. We claim that our glasses are the finest in the market and our style of fitting is the only proper method to obtain good results.

And our prices?—Well, if you would only give us the opportunity to fit your eye RIGHT—we feel almost ashamed to ask such low prices AS WE DO.

### The Jarck Optical Co.,

Makers of Fine Spectacles and Eye Glasses,  
473 FULTON STREET.

are particularly good. I do not think anybody will see them and not agree with me in that. Their merit is conspicuous and consists mainly in the fact that they contain perfectly plain, dignified talk, which sounds earnest and honest.

Samuel H. Brainerd, of Medina, O., writes that he enjoys reading my page in THE JEWELERS' CIRCULAR very much. He sends for criticism, two advertisements which would seem to indicate that he had not read these pages very carefully.

One of them says: "Samuel H. Brainerd, the jeweler, wishes to call attention to his large stock of silverware, consisting of butter dishes, cake baskets, tea sets, pickle castors, celery boats, cups and saucers, bon bon dishes, sugar and cream sets, etc." Not a single, solitary word of description in the whole ad. Just a mere catalogue of stuff that everybody knows that any jeweler who keeps silverware will be almost sure to have in stock.

There is room enough in Mr. Brainerd's six inch space to give a little description of half a dozen of these articles, to make some suggestion as to their usefulness and beauty, and to give the range of prices. The advertisement as it stands does not tell anything that everybody does not know, and an advertisement that does not convey some news is falling far short of perfection.

### Providence.

The next meeting of the Retail Jewelers' Association will be held in this city on Jan. 11th.

W. K. Seagrave, manufacturer of jewelers' saws, has removed from Aborn St. to 117 N. Main St.

Charles B. Broome has accepted a position with Bruhl Bros. & Co., as traveling salesman in the east.

Josiah Walsham, manufacturer of findings, has removed from 37 Beverly St. to Dudley St. near Eddy.

Eugene Stern, of S. M. Stern & Co., of Philadelphia, was registered at the Dorrance hotel the past week.

Mr. Cohen, of Cohen & Meisser, of Milwaukee, was in town the past week calling upon the manufacturers.

The annual meeting of the Manufacturing Jewelers' Board of Trade will be held Saturday afternoon, Dec. 29th.

Marden & Kettley have removed from 107 Friendship St., to the Beverly St. side of the Kent & Stanley Co. building.

George H. Cahoon & Co. have removed from 121 Weybosset St. to their new quarters in the Kent & Stanley Co. building.

J. M. Chandler & Co. have purchased all the tools, machinery and fixtures of E. F. Presbery, who recently gave up business at 119 Orange St.

W. W. Middlebrook, the New York representative of B. A. Ballou & Co., has been in this city the past week on his semi-annual visit to the factory, previous to starting on his extended western trip.

Miss Mabel Lowe, daughter of Edwin Lowe, president and treasurer of the Edwin Lowe Gold Plating Co., was united in marriage with Charles H. Daggett, at the bride's residence, last Tuesday evening.

The funeral of the late Albert Holt was solemnized from his late residence, last Tuesday afternoon, the interment being at Attleboro, Mass. The pall-bearers were Levi L. Burdon, Edward Tucker, George W. Downing, and Walter Ballou, of North Attleboro.

A member of the Tilden-Thurber Co. Thursday notified the police authorities that a few articles valued at about \$25 had been stolen from their store. The detectives were detailed to make an investigation, which resulted in the arrest of Arthur Thurber, 18 years of age, who has been employed at the place for about two years. Thurber was fined \$20 and costs.

### Pittsburgh.

S. Logan, watchmaker and engraver, has started in business at 40 Fifth Ave.

Harry B. Cubbison, New Castle, Pa., was here last week buying goods.

New show cases added to the storerooms of West, White & Hartman have done much to aid in attractiveness.

A charter has been issued to the Dia-

mondtime Mfg. Co., of Pittsburgh, for the manufacture of a mineral composition for the cleaning of diamonds; capital \$10,000; directors: Louis J. Selzewick, inventor B. F. Emery, N. Weicensary, I. Solomon, and George P. Pettit, all of Pittsburgh.

Quite a number of jewelers were in the city last week. Among them were: O. W. Bishop, Connellsville; H. A. Reineman; McKeesport; D. S. Pelton, Sistersville, W. Va.; Charles Kennerdell, Freeport; N. L. Marsh, Bellaire, Ohio; Geo. V. Brady, Washington, Pa.; John Linnenbrink, Rochester, Pa., and C. H. Hayes, Connellsville.

A. M. Frederick, a pipe organ builder from Jersey City, was arrested in Wheeling, Dec. 10, and sent to jail for stealing jewelry from J. W. Grubb's store. It is also charged that he had stolen elsewhere in the town. He was then arraigned before a magistrate and committed. He went to Wheeling highly recommended by church and musical people in Pittsburgh, where he was last employed.

### Philadelphia.

#### TRADE CONDITIONS.

The ante-Christmas business is under way in vigorous shape. Jewelers say it is in some respects in excess of expectations, and that it is a vast improvement on last year. Nearly all the big establishments have augmented their regular force.

James Horstman is confined to his home by a severe attack of typhoid fever.

The Chicago Merchandise Co. have begun a special holiday sale of jewelry and silverware at 305 and 307 N. 8th St.

Simon Muhr was a delegate to the Democratic convention last week, to revise the rules of the party organization in this city.

The window of Eugene Cramer's store, 3117 Germantown Ave., was smashed early on Monday morning last and a clock and a bronze figure were stolen.

Louis A. Scherr, son of Geo. W. Scherr, has finished his time as an apprentice at engraving, and is about to enter business practically. He has executed some very artistic designs in jewelry and plated ware.

Out-of-town jewelers who were on business visits here during the week included Robert Steel, Hammon, N. J.; John Fish, Bryn Mawr, Pa.; M. M. Bovard, Manayunk, Pa.; R. G. Porter, Woodbury, N. J.; Howard Fitzsimmons, West Chester, Pa.; W. Watson, Manayunk, Pa.; B. C. Foster, Bristol, Pa.; Mr. Fink, Lebanon, Pa.; Geo. Press, Oxford, Pa.

Louis Isaacs, 2043 N. 19th St., ex-policeman Alex. Shoneman, 154 N. 2d St., Elizabeth Spray, 930 Moyer St. and Lydia Snyder and George Kerns, 229 N. 5th St., were charged before Magistrate Milligan on Tuesday last with "conspiracy to cheat and defraud in setting up an auction and bidding upon goods. Policeman Roberts said the defendants were all connected

with an auction room on Market St., above 4th, where they, and other persons unknown, conspired to bid for goods in excess of the real value, to make sales which were bogus, and to wilfully misrepresent the character of the goods sold, to the loss of the public attending these sales. The witness testified that he had bought a watch and chain at auction from Shoneman, which were represented as gold filled and proved to be brass, and to other alleged misrepresentations of statements, and the defendants with the exception of the women, were held. Mrs. Snyder and Miss Spray were discharged, and the others were held for trial.

### Boston.

#### TRADE CONDITIONS.

Boston jobbers are busy, but Boston retailers are busier. The holiday rush is at its height and the jewelers began Saturday night, Dec. 8, to keep open until 9 p. m. The demand for sterling silver goods has been a feature of current trade, the stock available in some lines of tableware being taken as fast as it comes in sight. A noteworthy feature of the week's business has been a large bill sold by Manager Askenasy, of John B. Humphrey & Co., successors to H. T. Spear & Son, a single purchaser taking in miscellaneous items, goods to the value of nearly \$20,000. All the Boston jobbers report business so brisk that they can hardly find time to attend to it all. A number of the manufacturers and New York dealers will have their representative for this section located in Boston until New Year's, and at the hotels a score or more of the prominent drummers are thus quartered now.

George F. Blake has taken the stand occupied by the late Henry Greene on Cornhill.

The American Waltham Watch factory will be closed throughout the Christmas week.

A. T. Sylvester has been chosen by the Newton G. A. R. men as their delegate to the State encampment, soon to be held at Springfield.

Harry W. Oliver, jeweler, Chelsea, whose case is before the Suffolk insolvency court, had a meeting Dec. 14, and Jan. 18 a hearing on his application for a discharge will be heard.

Alfred N. Wood, who presided at the meeting of retailers, in the Chamber of Commerce rooms, December 4, has not as yet decided upon the list that will comprise the committee on nominations, to report Jan. 15, but states that he shall be ready to name his appointees between Christmas and New Year's.

The Manhattan Silver Plate Co., Lyons, N. Y., have laid off half a dozen men owing to a lack of sufficient orders to keep them employed. This is the first time in three years that this factory has been obliged to take such a step.

**Proceedings of the American Horological Society.**

CHICAGO, Ill., Dec. 15.—The regular monthly meeting of the American Horological Society was held on Wednesday evening, Dec. 12, President Parsons presiding. The applications of Adam H. Bolender, Rockford, Ill.; E. A. Walker, Baltimore, Md.; and Chas. Teske, Hartford, Conn., having been approved, they were duly elected to membership.

The secretary reported that 14 letters had been received during the month asking for application blanks, from persons desirous of being examined in practical work, with a view of securing the society's certificate. Many others sent in their names for examination under the idea that the examinations were conducted free of charge. The fee for examination is \$3.00, which must accompany the application, and if the applicant succeeds in passing the examination, a further fee of \$2.00 is required when the certificate is ready for delivery, except in the cases of members of the society in good standing, when the examination fee of \$3.00 only is required. Applicants for examination may become members of the society at the same time that they make their application for examination, and thus save \$1.00.

The questions in theory, used in the November examination, were as follows :

1. The distance between the regulator pins (curb pins) should not be greater than one and a half times the thickness of the balance spring. Why should the pins be so close together?
2. What is the pitch line of a wheel and a pinion?
3. A watch with a compensation balance keeps time in mean temperature, but gains with an increase of temperature. How would you correct it?
4. A watch has the following train: Center wheel, 96 teeth; third pinion, 12 leaves; third wheel, 75 teeth; fourth wheel and fourth pinion lost; escape pinion, 7 leaves; escape wheel, 15 teeth; the balance makes 5 vibrations per second. How many teeth must the fourth wheel have? How many leaves must the fourth pinion have?
5. A wheel of 76 teeth has a diameter of 15 mm., and the pinion which it drives has 10 leaves. What is the diameter of the pinion?

Examination papers and work for the January examination will be sent out on Jan. 16, and all applications must be in by the 15th of the month. The questions used in the November examination will be no guide, as the questions are changed with each examination. The board reports that the averages on theory were very high, but that the weak point of the applicants appears to be on the practical work.

The meetings of the society during the Fall and Winter months have been well attended, and the members take active part in all the proceedings and show

greater interest in the society's work. A large number of letters have been received from prominent watchmakers and jewelers throughout the United States congratulating the society on their adoption of the examination of watchmakers and expressing themselves as satisfied that in time it will abate the evil now existing in the trade, namely inferior workmen posing as expert watchmakers.

**Scovill Hitchcock Calls a Meeting of His Creditors.**

SOUTHINGTON, Conn., Dec. 17.—Scovill Hitchcock, a well-known jeweler, has called a meeting of his creditors for to-day. He is in financial difficulties and wants to make a settlement with his creditors. He will not give a statement of his assets and liabilities until the creditors meet.

**A Silversmith Arrested Charged With Counterfeiting.**

BIRMINGHAM, Ala., Dec. 15.—William Norris, aged 93 years, is in jail here charged with counterfeiting. It is alleged that he had in his possession at his home in De Kalb County, Ala., moulds from which spurious coins were made. Norris is a silversmith by trade and worked his trade at Greenville, S. C., for many years, where he also conducted a jewelry store for more than 50 years.

**The Stock of Charles L. Frantz Sold by the Sheriff.**

LANCASTER, Pa., Dec. 15.—The sheriff, on Thursday, sold the stock and personal property of Charles L. Frantz, the E. King St. jeweler, against whom executions were issued last week.

The amount realized was \$1,550, the first execution creditors being the purchasers. There will be absolutely nothing for the general creditors.

**The Elgin National Watch Co. Accused of Overworking Women.**

ELGIN, Ill., Dec. 12.—Abraham Bisno, deputy for Florence Kelly, factory inspector, has sworn out six State warrants for the arrest of George Hunter, superintendent of Elgin National Watch Co.'s factory, charging him with violating the factory law passed at the last session of the Legislature.

The action is brought for violation of the eight-hour for women clause. The law is regarded by the company as unconstitutional, and instead of being a benefit to the working girls it will be looked upon by them as a great hardship if they are compelled to abide by its provisions. In some of the factories, rather than have their operating hours interfered with, women employes have been discharged and replaced with men.

**Jeweler Simpson Could Not Bear His Son's Disgrace.**

SEDALIA, Mo., Dec. 13.—W. B. Simpson, a jeweler of Holden, Johnson County, died yesterday morning of a broken heart.

At Warrensburg, Tuesday, his son Charles, 18 years of age, was convicted of embezzlement and sentenced to two years' imprisonment in the penitentiary. It was announced that the lad would be taken to prison yesterday. Yesterday morning the father, who was in his usual health on Tuesday, was unable to leave his bed, and he died an hour before the departure of the train that carried his son to a convict's cell.

J. C. F. Cummings is a new jeweler in Brumfield, Ill.

J. H. Branhall, jeweler, 807 14th St., Washington, D. C., was robbed of two gold watches worth \$50, by a colored man, last week. The negro was looking at the watches, on the pretext that he wanted to buy one. With one in each hand he stepped to the door, as if to spit, and ran away.

**MATHEY BROS., MATHEZ & CO.**

21 & 23 MAIDEN LANE, N. Y.  
BRASSUS, SWITZERLAND.

MANUFACTURERS OF  
THE SMALLEST,  
THE THINNEST,  
THE NEATEST AND  
THE BEST

**SPLITS.**

SOLE AGENTS FOR

**JAQUES • LECOULTRE • RAZORS.**

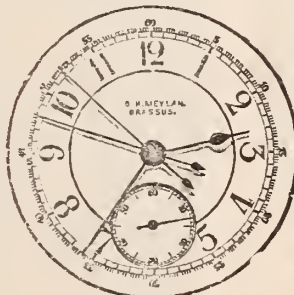

10 Size.



1 Size.

**THE ARTHUR CO.,** LEADING DESIGNERS AND BUILDERS OF  
**DIAMOND MACHINERY** IN THE UNITED STATES.

Machine Works, 86 John Street and 188-190 Front Street

# REED & BARTON, Silversmiths,

CHICAGO OFFICE  
34 WASHINGTON STREET.

37 UNION SQUARE, NEW YORK CITY.  
OFFICES AND FACTORIES, TAUNTON, MASS.

PHILADELPHIA OFFICE,  
925 CHESTNUT STREET.

## "LA REINE."

DESIGN  
PATENTED.

Trade Mark



Sterling

$\frac{925}{1000}$  FINE.

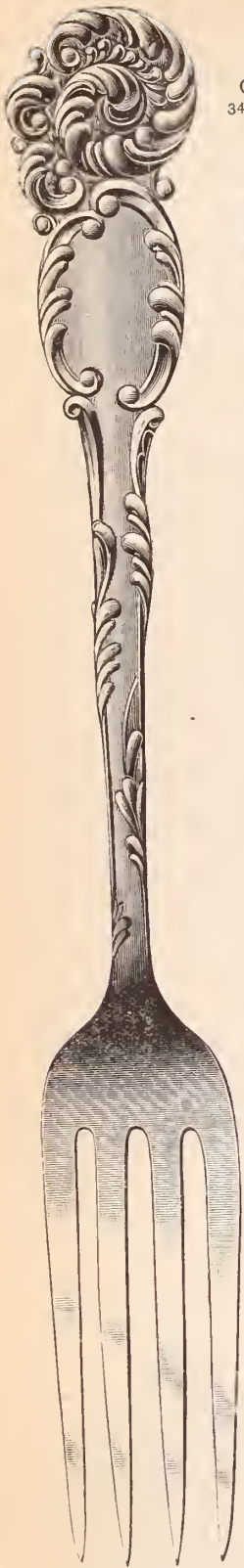

**Table Fork.**  
Average Weight to  
the Dozen.  
28 oz.



**Dessert Fork.**  
Average Weight to  
the Dozen.  
20 oz.



**Tea Spoon.**  
Average Weight to  
the Dozen.  
12 oz.



**Dessert Spoon.**  
Average Weight to the Dozen,  
20 oz.



**Table Spoon.**  
Average Weight to the Dozen,  
28 oz.

The "LA REINE" is one of the most popular patterns ever furnished to the trade.

The design is brought out in high relief, and for beauty and excellence of workmanship it stands unrivaled.

It is furnished in weights as mentioned under each article, and in heavier weights to order.

A complete variety of fancy pieces is made in this pattern, numbering over one hundred, and embracing the latest ideas in Silver Service, worked into the most pleasing and novel forms.

EXTENSIVELY ADVERTISED IN THE MAGAZINES FOR THE BENEFIT OF DEALERS.



# The Jewelers' Circular

AND  
HOROLOGICAL REVIEW.

PUBLISHED EVERY WEDNESDAY BY

THE JEWELERS' CIRCULAR PUB'G CO.,

189 BROADWAY, NEW YORK CITY.

A JOURNAL DEVOTED TO THE INTERESTS OF JEWELERS, WATCHMAKERS, SILVERSMITHS, ELECTRO-PLATE MANUFACTURERS, AND ALL ENGAGED IN KINDRED BRANCHES OF INDUSTRY.

Our Editorial columns will contain our own opinions only, and we shall present in other columns only what we consider of interest or value to our readers. Advertising matter will not be printed as news.

Advertising rates in THE CIRCULAR are lower, considering the number of tradesmen reached by its large circulation, than in any other jewelry journal.

Notices of changes in standing advertisements must be received one week in advance; new matter can be received up to Monday.

## INFORMATION FOR SUBSCRIBERS.

### Terms of Subscription, Postage Prepaid.

	PER ANNUM.
United States and Canada, - - -	\$2.00
Foreign Countries in Postal Union, - - -	4 00
Single Copies, - - - - -	.10

New subscribers can commence at any time.

Payments for THE CIRCULAR when sent by mail, should be made in a Post Office Money Order, Bank Check or Draft, or an Express Money Order or Registered Letter. All postmasters are required to register letters whenever requested to do so.

Pay money only to authorized collectors having proper credentials. Returning your paper will not enable us to discontinue it, as we cannot find your name on our books unless your address is given.

In changing address always give the old as well as the new one. Your name cannot be found on our books unless this is done.

We will continue to send papers until there is a specific order to stop, in connection with which all arrearages must be paid; but such an order can be given at any time, to take effect at the expiration of the subscription. All such orders will be promptly acknowledged by mail.

The Courts have decided that all subscribers to Journals are responsible until arrearages are paid in full and an order to discontinue has been received by the publisher.

Member of the American Trade Press Association.

Vol. XXIX. Dec. 19, 1894. No. 21.

Every line of reading matter in THE JEWELERS' CIRCULAR, with the exception of the few brief extracts from exchanges always properly credited, is written exclusively for this journal. Each issue of THE JEWELERS' CIRCULAR is copy-righted.

THE holiday trade is on with a rush, and reports from all parts of the country denote a satisfactory condition of business. THE CIRCULAR extends to the trade the compliments of the season, and prays that all will enter upon the holiday divertisement with content in the present and hope for the future.

THE Pacific Coast States have of late loomed up alarmingly as a land of sensational failures in the jewelry industry; yet reports regarding trade have during the past season generally reflected satisfactory conditions.

CECIL RHODES, whom the *Figaro* has surnamed Napoleon of the Cape, in-

tends paying a visit to Paris. He will doubtless be received with more curiosity than sympathy, for his ideas on colonization are hardly in accordance with those of France.

A trade which has recently sprung into life is in our judgment an attempt to make "gain of godliness." We refer to the traffic in "individual cups" for the Lord's Supper. Enterprising manufacturers, with "an eye to the main chance," have taken advantage of the scare of certain fashionable church circles, growing out of the discovery of "microbes," or disease germs, on the rim of the cup containing the communion wine, and are offering for sale very small glasses in which the wine can be passed separately to the communicants.—*Christian Advocate*.

IN manufacturers supplying the demand for individual communion cups, we see no truer attempt to make "gain of godliness" than in builders erecting churches, artists decorating churches, or artificers weaving the fine fabrics of church raiment. The circumstance and pomp of church and religion foster many industries, and it is the law of supply and demand that governs the production of individual communion cups.

### Jewelers Discriminating Against Themselves.

THE Mayor of San Diego, Cal., points out to the jewelers of that city that in their anxiety to prevent auction sales by traveling jewelers they have discriminated against themselves. By imposing a tax of \$15 a day, to be paid six months in advance, on auctioneers of jewelry, the established firms of San Diego must pay into the city treasury \$2,730 before they will be permitted to conduct an auction sale, while outsiders can open a store and sell goods in competition with the old jewelers for six months by paying \$50. If these circumstances are true, it now behooves some sagacious member of the trade in San Diego to devise an ordinance that will lack the objectionable features of the one referred to, which the Mayor promptly vetoed.

### Silver Testimonials to the Naval Ships.

THE popular enthusiasm aroused by the building of Uncle Sam's new navy has found expression in many costly gifts presented by cities to the ships of war designed to be a bulwark of the nation. These gifts have in the majority of cases, been in the shape of silver sets, the Maine, New York, Detroit, Cincinnati, Montgomery and Charleston being among the vessels whose names occur to us that have been so honored. The latest manifestation of such a character is the movement among the people of Minneapolis to donate a silver service to the cruiser christened in honor of this city. While several valuable testimonials outside of silverware, containing elements of utility, or reflecting sentiment have been presented to new ships in the navy, the silver services have excited the greatest measure of favorable consideration. A silver service for the officers of a ship of

war is the handsomest and most useful gift that can well be chosen. A great deal of entertaining takes place on board of such a vessel while in port, and it is only very recently that the Navy Department has gone so far as to allow even an equipment of plated ware to the wardroom.

### Silver Stamping Legislation in the States.

ELSEWHERE in this issue of THE CIRCULAR are printed a number of letters so far received from the jewelers throughout the United States reporting progress in the obtaining of legislation to govern the stamping of silver manufactures, as represented in a common bill drafted by THE CIRCULAR. From these letters we derive the following summary: *Maine*, the measure will be presented to the Legislature, which meets in January, and it seems there is no doubt that it will be passed; *Connecticut*, the bill slightly amended as to penalty, will be placed in charge of F. L. Tibbals, of the Geo. H. Ford Co., New Haven, and member of the State Legislature; *Georgia*, the bill has been before the Legislature, but its progress has been retarded by obstructive measures which the present session has been laboring with; *South Carolina*, the matter has been introduced in the Legislature as directed; *Missouri*, the measure will receive attention in the next session of the Legislature, being heartily endorsed by the largest jewelry firm in the State; *Indiana*, the firm selected will endeavor to have the bill carried through; *Kentucky*, the Legislature does not meet till the Fall of 1896, but in the meantime the bill will be pushed as earnestly as possible; *Nebraska*, the Legislature will deal with the bill which has been endorsed by the principal jewelers of Omaha; *Louisiana*, the Legislature does not convene till one year from next May. The jewelers of the remaining States have not yet communicated with THE CIRCULAR. From the foregoing it will be seen that besides the two States which have dealt favorably with legislation to regulate the stamping of silver manufactures, nine other States will pass judgment upon a bill in common. There is little doubt that all these States will ultimately pass the measure, and when this is achieved a much needed law will be practically universal throughout the country.

### Newell G. Benjamin Commits Suicide.

SPRINGFIELD, Mass., Dec. 17.—Newell G. Benjamin, aged 37 years, a prominent jeweler of Pittsfield, committed suicide by shooting himself through the head, at his home, this morning.

He went to Albany yesterday and did not return until this morning. When he came home his wife noticed that he acted strangely, and in fear she ran upstairs to her room. Her husband stepped into the parlor and placing the pistol against his temple shot himself. He died almost instantly,

### New York Notes.

Tiffany & Co. have filed a judgment for \$187 against Geo. E. Pollock.

S. & B. Lederer have filed a judgment for \$93.86 against Isaac Harrison.

C. M. Levy has filed a judgment for \$126.70 against Morris Levinkind.

E. E. Kipling has entered a judgment for \$430.32 against Geo. A. French.

A judgment for \$91.32 has been entered by S. Firuski & Son against Moritz Weinberg.

A judgment against the Duryea Jewelry Co. for \$104.80 has been entered in favor of S. & B. Lederer.

A judgment against James N. Holden for \$140.16 has been entered in favor of the Bristol Brass & Clock Co.

The judgment for \$245.83, which B. H. Davis & Co. filed against Edward Clark, May 4, 1894, has been satisfied.

The judgment for \$256.43 entered March 29th, 1890, by F. E. Leimbach against Edward H. Dederick, has been satisfied.

Auctioneer J. H. French continued last week, at 20 E. 14th St., the sale of the stock of the retail department of Simpson, Hall, Miller & Co.

Hugo S. Mack, assignee of Charles E. Hansen, advertises for creditors of Hansen to present their claims at the office of Henry Brill, 7 Beekman St., on or before Feb. 2d, 1895.

A motion to vacate the judgment for \$631.38, which Jno. N. Disselkoe entered last week against The Free Premium Club, was denied without costs by Judge Van Wyck, of the City Court, Friday.

Joseph Brull, of Jos. Brull & Sons, retail jewelers, 35 Avenue A., has resigned from the position of inspector of schools for the Fourth district. Mayor Gilroy, Thursday, appointed Jno. L. Hoffman as his successor.

John Mayo, a captain of a canal boat, was held for trial Friday by Police Justice Grady in the Tombs Police Court on the charge of having forced an entrance into the jewelry store of Alfred Rosenthal, 20 New Bowery, early that morning.

John Kenny, who smashed the window of David Marks' jewelry store, 334 Bowery, on the night of Nov. 19th, and stole a quantity of jewelry, was tried in General Sessions Wednesday last. He was convicted and remanded for sentence. He has spent 13 years in prison for burglary.

The firm of Vve. L. B. Citroen & Co., importers of diamonds, 30 Maiden Lane, will, it is positively stated, liquidate and wind up business early next year. N. Kauffman, of this firm, has not definitely decided whether or not he will remain in the diamond business.

August Kurtzeborn, Meyer Bauman, Edmund Achard and Morris Eisenstadt, all of St. Louis, were examined last week before Thos. B. Harlan, of that city, as referee. Their testimony will be introduced by the plaintiffs in the suit brought in the New York Supreme Court, by the Dueber Watch

Case Mfg. Co. against the manufacturers of watch cases and movements.

Vincent J. Bevanatti, was arraigned in the Butler St. Police Court, Brooklyn, Friday on a charge of grand larceny preferred by William McDougall, jeweler, 223 Columbia St. On July 23d last the prisoner entered McDougall's store and under pretence of purchasing, took two pairs of diamond earrings valued at \$170 to the door to better examine them and then fled. Justice Tighe remanded Bevanatti for examination in \$2,000 bail.

By an order of Judge Van Wyck, of the City Court, filed Thursday, a commission is to issue in the action of A. Lounsbury & Son against The Jewelers' Safety Fund Society to O. B. Jameson, of Indianapolis, who is authorized to examine on interrogatories, A. G. Fiel and J. D. Brown, of that city, who are witnesses on behalf of the defendant company. The action is brought by Lounsbury & Son to recover the insurance on about \$300 worth of jewelry which they claim was delivered by the express company to some one other than the consignee.

Two young men, who gave their names as Michael Appleton and Wm. Brown, were captured early Sunday morning in West New Brighton, S. I., while making away with a quantity of jewelry they had stolen from the jewelry store of Jas. L. Beeman, of that town. The two had taken out a pane of glass and had lifted all the small jewelry that had not been locked up in the safe. When searched at the station house two small watches, three gold rings, two pairs of gold earrings and some gold pins were found on them. The prisoners were taken before Justice Langton and remanded for further examination.

Geo. Carlton Comstock, counsel for Wm. H. Glover, may appeal from the decision of Judge McAdam published in full in THE CIRCULAR, Oct. 31st. This decision denied the motion for a new trial of the action by which Edw. B. La Fetra, assignee of Chas. Seale, obtained a judgment against Glover for the value of a diamond brooch which was obtained from Seale on memorandum by the "Baroness" Blanc, who pawned it with Glover. The appeal if taken will be argued in February before the General Term of the Supreme Court. If, however, Seale's assignment is set aside on another action now pending, no appeal will be made.

Working nights has not been a common feature in the Maiden Lane establishments for some time, and it is, therefore, worthy of comment that during the past month the entire force of S. F. Myers & Co. have been kept busy three nights in the week filling orders. This is the best advertisement that a house can receive, as it is an evidence of their popularity in the trade.

Though the season for watch jobbers is about over Schauweker & Chalmers, Venetian building, Chicago, report a comfortable increase in sales over those of the previous week.

### Special Board Decide That Diamond Cutting is a New Industry in America.

The Special Board of Inquiry sitting at Ellis Island, to determine the status of A. Hoed, a diamond polisher alleged to have been brought to this country in violation of the Contract Labor Law, finished its hearing Thursday afternoon, and rendered its decision.

As told in THE CIRCULAR last week, the diamond cutting firms in and around New York took this opportunity to make a test case in order to obtain a ruling on Section 5 of the statute which states in effect that the law does not apply to men in "new" industries. Through their counsel, Samuel Greenbaum, they claimed that diamond cutting was a "new" industry within the meaning of the statute and therefore, admitting Hoed to have been under contract, he could not be detained. The Labor Unions who were said to be behind the Government in this fight, attempted to show that diamond cutting was an established industry in this country, giving employment to about 50 men.

Mr. Greenbaum claimed that the factories previously established were merely for the purpose of re-cutting, matching, and possibly cutting a small amount of rough necessary to keep the men employed, and also claimed the mere fact of the existence of one or two factories did not prove the industry to be established; that America never cut as much as \$200,000 worth per annum, while our importations of cut stones averaged in recent years about \$12,000,000; and that the amount cut, therefore, less than 2 per cent., was not sufficient to give the dignity and character of an industry to American cutting.

After hearing the testimony of nearly all the proprietors of the diamond cutting shops, the views of prominent members of the trade and other witnesses, the board by a vote of three to one decided in favor of Mr. Greenbaum's interpretation of the law, namely, that diamond cutting is a "new" industry within the meaning of Section 5, and that the contract labor law could not yet apply to persons engaged in that trade.

The dissenting commissioner gave notice of appeal to Superintendent of Immigration Stump, and the case will be argued before him, it is expected, within a week. The final decision, however, lies with the Secretary of the Treasury to whom it may be then appealed, unless he hears the case with Superintendent Stump.

A Goldman, clothing and jewelry dealer, St. Joseph, Mo., went to Hannibal last week to identify a quantity of jewelry supposed to be the same that was stolen from his store a couple of weeks ago. Two men were arrested in Hannibal with the booty in their possession. When the Hannibal officers heard of the burglary their suspicions were aroused with the result that Goldman was notified. He recognized the property as his.

**L. TANNENBAUM & Co.,**  
 IMPORTERS AND CUTTERS OF  
**Diamonds and Precious Stones,**  
 Cor. Maiden Lane & Nassau St.  
 NEW YORK.  
 25 Hatton Garden, London.  
 TELEPHONE, LONG DISTANCE, 1959 CORTLANDT.

## Special Announcement.

Mr. L. Tannenbaum begs to notify his customers and the trade in general, that he has largely extended his facilities for cutting and polishing. Hereafter he will cut and polish not only RUBIES and SAPPHIRES, which has been done for the past 15 years with increasing and gratifying success, but

# DIAMONDS

and all other stones which undergo this process.

Modern machinery of the best and most approved pattern, and workmen of the highest class will enable Mr. Tannenbaum to offer, direct from the cutter's hands, that excellent workmanship demanded by American buyers, at

## PRICES THAT DEFY COMPETITION.

Nor will buyers of Diamonds be the only people benefited. Mr. Tannenbaum imported a five years' supply of rough Rubies and Sapphires DUTY FREE under the old tariff. These goods are now being cut and polished and it is very evident that in these particular stones he can make UNAPPROACHABLE PRICES.

New York as the future Diamond Market is not a phantasy. American cutters will be shown an assortment of rough, at prices which will perhaps cause them to believe that this has already been brought about. All arrangements have been made by the firm for enormous shipments of DIAMONDS, EMERALDS, PEARLS, SPINELS, CATSEYES, MELLÉS and all kinds of Precious Stones, although to-day the assortment offered by L. Tannenbaum & Co. ranks second to none in this country.

HIGHEST PRICE PAID for all AMERICAN PEARLS and OTHER PRECIOUS STONES.

## Our Traveling Representatives

Traveling representatives may consider these columns open for the publication of any news or items of interest regarding themselves or their confères.

**O**SCAR Daringer, traveler for Nichols, Pee & Co., Indianapolis, is back from an extended trip in Indiana. His trade in tools and materials has been very good, but quieted down when the Christmas rush began.

Traveling men in Indianapolis, Ind., last week included: Herbert W. Van Houten, Sinnock & Sherrill; Coleman Adler, Ernest Adler; Willard Veit, Marx, Veit & Co.; I. S. Richter, Bruhl Bros. & Co.

President Wales is in the Hub and is preparing for a lively session of the jewelry travelers, at the Quincy House, Boston, next Friday evening. Responses to date promise a good attendance and a jolly gathering.

Salesmen in Philadelphia the past week included: C. Hudson, H. F. Barrows & Co.; Mr. Thompson, for Henry Glorieux; A. M. Leibman, E. P. Reichhelm & Co.; Wm. Wightman, R. F. Simmons & Co.; Geo. B. Osborn, Wm. Smith & Co.

Mr. Atwood, traveler for the Towle Mfg. Co., is visiting at his home in Amesbury, Mass. Mr. Ryan, representing the house in Kansas and Nebraska, returned to Chicago the past week. He was accompanied by Mrs. Ryan on his recent trip.

The following traveling salesmen passed through Detroit recently: F. M. Wheeler, Dominick & Haff; H. J. Fink, Keller, Ettinger & Fink; Stephen Woods, Battin & Co.; F. H. Carpenter, Alfred H. Smith & Co.; Mr. Shaw, The Kent & Stanley Co.; and L. H. Smith, Bippart & Co.

Traveling men visiting Davenport, Ia., the past week were: W. H. Allardyce, Edward Todd & Co.; S. W. Frohlichstein, Henry Froehlich & Co.; Alfred G. Stein, L. H. Keller & Co.; M. H. Lebolt, H. F. Hahn & Co.; M. Smith, Kent & Stanley Co.; C. E. Patterson, Towle Mfg. Co.; Mr. Sisco, Ansonia Clock Co.; and Abe Jandorf.

Travelers in Pittsburgh, Pa., last week were: Jacob Adler, L. & J. Adler & Co.; Mr. Hartung, Sussfeld, Lorsch & Co.; Frank Carpenter, A. H. Smith & Co.; Frank Kennion for John T. Mauran; Wade Williams, Annold & Steere; E. W. Drury, Non-Retailing Co.; Lawrence H. Smith, Bippart & Co.; Wm. T. Gough, Carter, Sloan & Co.; L. E. Smith, M. B. Bryant & Co.; H. A. Bliss, Kremetz & Co.; I. S. Richter, Bruhl Bros. & Co.; Mr. Crane, Strobell & Crane; Matthias Stratton, Jr., John W. Reddall & Co.; C. B. Bray, Shafer & Douglas; Thos. E. Rogers, Hayes Bros.; Charles Perrit, Jules Racine & Co.; G. C. Booth, Hutchison & Huestis; and A. Peabody.

### Canada and the Provinces.

The stock of the estate of Joseph McClelland, Peterboro, Ont., has been sold.

Olmsted & Hurdman, jewelers, Ottawa, Ont., moved to their new store on Dec. 11.

Geo. Smith, representing the Montreal branch of Simpson, Hall, Miller & Co., has just returned from a successful trip to the Pacific coast.

T. D. Gagnon and Geo. Haycock have formed a partnership and will conduct a jewelry business in Lachine, Que., under the name of T. D. Gagnon & Co.

E. C. Fitch, president of the American Waltham Watch Co., arrived in Montreal last Saturday, and after remaining in the city a day or two left for Chicago.

D. Gordon, Toronto, has leased the store, 350 Yonge St., formerly occupied by Chas. Spanner, and has opened the same as a

jewelry store. Mr. Gordon has had the place enlarged and refitted in the latest style.

The death occurred of Frank J. Climo, at the residence of L. Stinson, 215 King St., east, Toronto, Monday last. He was 28 years of age. Mr. Climo was formerly a jeweler in that city and subsequently traveled for a Montreal house.

About 1 o'clock of the morning of Dec. 7, F. G. Dockrill, jeweler, 2118 Notre Dame St., Montreal, was awakened by the watchman, and was informed that a pane of glass in his window has been pushed in and a quantity of goods taken. He came down into the store, fixed up the window, and seeing some one crossing the street a block away, hid himself behind the door. Dockrill followed him and caught him in a lane off Notre Dame St. He gave his prisoner in charge and then went home. A quantity of the jewelry was found on the prisoner.

The wholesale catalogue recently issued by the Diamond Point Pen Co., 7 Astor House, New York, contains 16 pages of matter of interest to retail jewelers. Between its pages will be found descriptions, illustrations and prices of the gold pens, fountain pens, penholders, pencils as well as the silver novelties, watches, jewelry and optical goods handled by this company.

When you buy

Cut Glass

You want the best!

That which bears our Trade Mark

Has no superior

And will prove profitable and satisfactory.

## T. B. CLARK & CO., INC.,

860 Broadway, N. Y.,

Factories, HONESDALE, PA.

N. E. Cor. 17th St. & Broadway.

# ORANGE SPOONS

Do you want a line of ORANGE SPOONS or ORANGE SETS which will give credit to your store?



RIALTO ORANGE SPOON.

HAVE you seen our ORANGE SPOONS and ORANGE SETS? Send for special prices.

OUR ORANGE SETS are put up in fine satin lined cases. Jewelers everywhere say, "The best line of goods made."



WESSELL ORANGE KNIFE.

Our New York Salesroom, 2 MAIDEN LANE, Second Door from Broadway, carries a full line of

STERLING SILVER HOLLOW WARE, NOVELTIES AND PLATED WARE.

## THE HOLMES & EDWARDS SILVER CO.,

BRIDGEPORT, CONN.

## News Gleanings.

C. L. Kerr has opened a jewelry store in Shelby, O.

Sam Williams has opened a jewelry shop in Bucklin, Mo.

Lyman Barnett has opened a jewelry store in Omro, Wis.

W. Morris has opened a new jewelry store in Chenoa, Ill.

Frank Levy has opened a jewelry shop in Hitchcock, S. Dak.

Fred. C. Sanborn has opened a repair shop in Gorham, N. H.

Israel Moore has removed from Ord, Neb., to Carthage, Mo.

E. L. Watkins, Factoryville, Pa., was married last Wednesday night.

Morris May, Trenton, N. J., announces that he is going out of business.

O. W. Andreae, San Antonio, Tex., has made a general assignment.

In a fire in Terre Haute, last week, the store of Jacob Kern was damaged.

B. S. Witham, formerly a jeweler of Gaylord, Kan., is now located at LeRoy, Kan.

Charles H. S. Lowe will start a jewelry store and repair shop in Munnsville, N. Y.

J. H. Seymour has opened a new jewelry store at 430 Commercial St., Portland, Ore.

J. C. Davenport has opened a jewelry store in the post office building, Mayo, Fla.

Shannon Bros., jewelers, Altoona, Pa., are now in their new room, 1513 Eleventh Ave.

Earl Parker, Georgetown, N. Y., has moved his jewelry business into a new store.

L. F. Terry, South Royalton, Vt., has removed his jewelry business into a new block.

Wm. Beebe and Geo. Barber have opened a jewelry store in Mr. Beebe's building, Adderly, Ia.

It is reported from Tasmania that numbers of stones found at Corinna prove to be diamonds.

John Kray, watchmaker, Desplaines, Ill., was married recently to Miss Addie Keenan, of Geneva Lake, Wis.

John Kennedy, Jr., jeweler, Wilkinsburg, Pa., was married recently to Miss Annie Stitt, of Wilkinsburg.

Mr. Karns, a silversmith of Ossian, Ind., is looking for a location to open a jewelry store and repair shop.

In a fire in Tingley, Ia., the jewelry business of O. S. Martin suffered to the extent of \$500. Fully insured.

Numerous compliments are heard here respecting the very complete retail catalogue issued by J. N. Mulford, Memphis, Tenn.

R. P. Hudson, optician, Nashville, Tenn., has come down from the fifth floor in the Cole building to the first floor at 222 Union St.

A. Sartor, San Antonio, Tex., has removed to a new and elegant building at 118 W. Commerce St.

Burglars a few days ago robbed Mrs. H. H. Brown's millinery store, Altamont, Ill., of several hundred dollars' worth of jewelry.

F. Overstreet, Farmer City, Ill., who some weeks ago sold his stock of jewelry to Stiller Bros., has again gone into the jewelry business.

Greenleaf & Crosby will open their branch jewelry store at Palm Beach, Lake Worth, Fla., about Dec. 23d. Miss Carpenter will be in charge of it.

Alfred H. Wright, who recently disposed of his business in Putnam to F. X. Lucier, has purchased the Phelps jewelry store in Whitford-Ellis block, Southbridge.

George O. Cowell, of the firm of Cowell & Hall Mfg. Co., jewelers, Wrentham, Mass., formerly of North Attleboro, died at the Taunton Insane Asylum recently.

Johnson Bros., jewelers, Canton, S. Dak., have been closed upon a mortgage held by B. F. Norris, Alister & Co., Chicago. A sale of the stock took place on Dec. 15.

Taintor & McAlpine, the Easthampton jewelers, are going out of the jewelry business, and will sell their stock in order to devote their whole time to a bicycle business.

Among the best shots that participated in the annual tournament of the West End Gun Club, of Davenport, Ia., last week, was A. Sunstrom, jeweler, of Bancroft, Ia.

S. D. Crockett and Lyman C. Bailey filed articles of incorporation recently with the county auditor for the Seattle Watch Co., of Seattle, Wash., naming a capital stock of \$1,000.

McDonald Bros.' store, Tilden, Neb., was recently burglarized, jewelry and watches to the value of \$200 being taken. A reward has been offered for the capture of the thieves.

Barrett & Sherwood, San Francisco, Cal., have removed to 9 Geary St. The firm carried on the jewelry business for many years on Montgomery St., in the Occidental Hotel building.

E. S. Green, Roanoke, Va., has recently refitted his store.—new ceiling and wall decorations, a general rearrangement of furnishings, and a fine line of art goods—a comparatively new feature with the house.

Arthur Ramser, jeweler, Rock Island, Ill., was one of a party of 14 children and 15 grandchildren that participated in the celebration of the 38th wedding anniversary of his father and mother, at their home in the city named last week.

The Gundlach Optical Co., Rochester, N. Y., have in process of erection a new building for their works at the southwest corner of South St. and Monroe Place. The block will have a frontage of 60 feet on South St. and 120 feet on Monroe Place and will be four stories high. It is to be ready for occupancy by March 1st.

The Linden Mfg. Co., Aurora, Ill., are building an addition to their plant. The company manufacture watch staffs, jewels and watch specialties and now employ 20 hands, but the growing business demands more room and more help.

The jewelry store of Grant Slack, Fremont, Neb., who made an assignment some time ago, has been sold at mortgagee's sale. The stock was sold in a lump and was bid in by C. Christensen, one of the creditors. The price realized was \$1,000.

The A. Gluck Jewelry Co., of Dodge City, Kan., have incorporated to "buy, sell and deal in watches, jewelry of all kinds, and diamonds." The incorporators are A. Gluck, Monta Gluck and Louis Loebner, all of Dodge City. The capital stock is \$5,000.

William Erkelens has opened an optical office at 57 S. Fullerton Ave., Montclair, N. J. He is a graduate of the Julius King Optical Co.'s school, New York, and is enthusiastic in his expressions of approval of this company's system of instruction, and of their courtesy.

The jewelry store of J. D. Jenson, Henderson, Ind., was burglarized some days ago and about \$300 worth of spectacle frames and opera glasses stolen. Entrance to the store was effected by prying the front doors open by means of an iron bar. There is no clue to the thieves.

The jewelry store of James A. Nelson, Decatur, Ala., was robbed a few nights ago of about \$600 worth of watches and other jewelry. The robbers entered by inserting a "jimmy" between the doors and prying them apart until the bolt slipped past the latch. There is no clue to the robbers.

Boyle, Davis & Goodman, jewelers' auctioneers, 611 Pennsylvania Ave., Washington, D. C., announce that their dates for sales for the month of December are all filled, and that they are now refusing applications from jewelers who want to make sales previous to Jan. 10, 1895. Their staff of able representatives are now distributed from the Gulf of Mexico to Maine. George Levy reports a very successful sale from Meridian, Miss., the goods bringing good prices and large audiences at all of his daily auction sales. Genial Mr. Sunderland is dispensing bargains with a liberal hand in Portsmouth, Va., and reports that the store room is not half big enough to entertain the audiences that attend. The people of Brockton, Mass., are turning out *en masse* nightly to hear Mr. Goodman, who is engaged in selling one of the largest stocks of jewelry carried in that city by one of the oldest established jewelers. Geo. Parker is in Troy, N. Y., selling the stock of one of the oldest landmarks of the jewelry trade of that city. He reports business as very good. Geo. Thayer reports his sale in Plymouth, Pa., as satisfactory in all respects, and the firm's reliable standby, that pioneer of the jewelry auction business, Thomas Baldwin, is busy at Baltimore, Md. Mr. Davis is busy at Washington, D. C. Thus the firm have no reason to cry hard times.

**DIAMONDS.****Wm. S. Hedges & Co.,****Importers of Diamonds,**

And Manufacturers of DIAMOND JEWELRY.

**170 Broadway, New York.**

22 Holborn Viaduct, London.

**Alfred H. Smith & Co.,**IMPORTERS**DIAMONDS**

AND

PRECIOUS STONES,**82 BROADWAY, COR. JOHN STREET,**

NEW YORK.

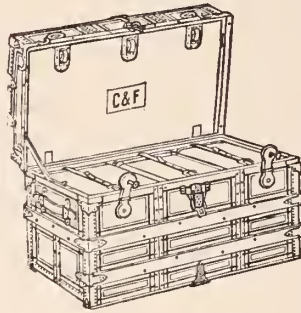
**83 Holborn Viaduct, London, E. C.****R. A. KIPLING,****Precious Stones**AND **Fancy Goods****Bought and Sold on Commission.****19 RUE DROUOT,****PARIS, FRANCE.****CROUCH & FITZGERALD.**Jewelry Trunks -  
and Cases,  
161**Broadway,**  
Bet. Cortlandt and  
Liberty Sts.,  
**688 B'way,**  
**701 6th Ave.,**  
NEW YORK.**Last Week's Arrivals.**

The following out-of-town dealers were registered in New York during the past week: E. E. Fay, Worcester, Mass., Murray Hill H.; J. W. F. Podmore, Troy, N. Y., Astor H.; W. F. Nye, New Bedford, Mass., Astor H.; J. F. Ellis, Toronto, Can., St. Denis H.; J. A. Jerger, Thomasville, Ga., New Amsterdam H.; W. J. Haines, Philadelphia, Pa., Marlborough H.; J. Zineman, Philadelphia, Pa., Albert H.; J. A. Williams, Boston, Mass., Imperial H.; V. A. Moore, Atlanta, Ga., Everett H., J. Karr, Washington, D. C., Imperial H.; E. G. Lloyd, Scranton, Pa., St. Cloud H. L. Emery Jr., Bradford, Pa., Imperial H.; A. Mayer, San Francisco, Cal., Stewart H.; J. G. Whittier, Providence, R. I., Grand H.; C. D. Rider, Danbury, Conn., Grand H.

**Postmasters Ordered to Seize Packages of Jewelry Sent in the Mails.**

WASHINGTON, D. C., Dec. 17.—The Post Office Department has received information that certain "fake" jewelry concerns are operating an extensive swindling scheme, and that postmasters in different parts of the country are being made the innocent means of furthering the designs of the swindlers. The scheme of the companies is to send a box of worthless jewelry to a certain person, who, when he receives it, naturally says it does not belong to him. The box or package is then returned to the post office in that locality. On the package is a notice to open it, and "within will be found stamps to pay for its transmission to the sender."

When one of the "fraudulent" companies receives the package, a letter is sent to the person to whom it was addressed, saying that he opened it and abstracted a pair of cuff buttons or something of that sort, and adding that a dollar or so sent to the writer would make the matter all right. If objection to making a payment is made by the innocent person, he is usually dunned in such a manner that the sum asked for is paid to avoid further annoyance.

Acting Postmaster General Jones says there is no way for the department to reach the promoters of this scheme, except by having postmasters seize all such jewelry packages, and consequently this afternoon he issued an order to postmasters to that effect.

The death occurred Dec. 13 of Louis F. Brown, senior partner in Brown & Anderson, Wilmington, N. C., at the age of 43 years.

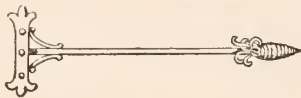

**GEO. W. SHIBLER & CO.**  
SILVERSMITHS

**179 BROADWAY, N.Y.**

**KELLER, ETTINGER & FINK,**

SELECTION ORDERS SOLICITED.

**24 JOHN STREET, NEW YORK.**

DEALERS IN

MOUNTERS OF

IMPORTERS OF

**American Watches.****Fine Diamond Jewelry.****Diamonds.**

**Connecticut.**

N. L. Bradley, Meriden, has gone to Chicago on a business trip.

Henry B. Hall, Wallingford, is home from a successful business trip west.

The J. D. Bergen Co., Meriden, have commenced erecting a large addition to their works.

The George H. Ford Co., New Haven, have converted the top floor of their building into workshops.

Walter Camp, of the New Haven Clock Co., has returned from his three months' stay on the Pacific coast.

The Seth Thomas Clock works at Thomaston are working overtime owing to the large number of orders.

N. Oisen, of Bridgeport, will dispose of his entire stock at auction. Mr. Oisen will devote his attention to watch repairing, umbrella and parasol trade.

J. H. Woodward, traveling salesman for the Derby Silver Co. for the last four years, has resigned, and is assisting at Geo. H. Ford Co.'s store, New Haven, for a few weeks.

Mr. and Mrs. Irving Ingraham, of Bristol, left for Florida last week. On their way they will stop at Washington, D. C., and Asheville, S. C. They will not return for several months.

Gen. Geo. H. Ford, New Haven, was Dec. 12, elected to an official position in the Society of Colonial Wars of the State of Connecticut, a society in the formation of which he has been active and prominent.

The Mutual Benefit Association of the Holmes & Edwards Silver Co., Bridgeport, gave a benefit literary and musical entertainment at Warner Hall in the Y. M. C. A. building Dec. 10 for charitable objects.

The annual meeting of the Meriden hospital incorporators was held Monday evening and the old board of directors was re-elected. Among the members are N. L. Bradley, Walter Hubbard and Charles Parker.

Within a week or two there will probably be another incorporated concern in Meriden, the T. Niland Co. It will take the place of the firm recently started by Thomas Niland and Thomas Burgess to carry on the glass cutting business in a part of M. B. Schenck & Co.'s factory, on Center St. The Niland Co. will organize with a capital of \$15,000 or \$20,000.

N. L. Bradley, of the Bradley & Hubbard Mfg. Co., Meriden, received a telegram Dec. 15th, stating that his brother, William L. Bradley, had died of heart disease at his home in Hingham, near Boston. He was 68 years old. For 25 years he was traveling salesman for the Charles Parker Co., and was considered the most popular and best salesman they ever had on the road. Along in '70s he went to Boston and engaged in the phosphate business. He was also for many years interested in the Bradley & Hubbard Mfg. Co., but some me ago sold out his stock there.

ESTABLISHED 50 YEARS.

**RANDEL, BAREMORE & BILLINGS,**

IMPORTERS OF

**DIAMONDS,**

AND OTHER PRECIOUS STONES.

**FINE PEARLS A SPECIALTY.**

MANUFACTURERS OF

**DIAMOND JEWELRY,**

IN THE LATEST DESIGNS.

Diamonds Recut in Modern Styles or Repaired on Premises.

58 Nassau Street,  
29 Maiden Lane,  
NEW YORK.

1 Tulp Straat,  
AMSTERDAM.

1 St. Andrews St.,  
Holborn Circus,  
LONDON, E. C.



TRADE MARK.

ESTABLISHED 1841.

**CARTER, SLOAN & CO.,**

**MANUFACTURERS OF GOLD JEWELRY,**

No. 15 MAIDEN LANE,

NEW YORK.

A. CARTER JR.  
A. K. SLOAN.  
C. E. HASTINGS.

GEO. R. HOWE  
WM. T. CARTER  
WM. T. GOUGH.

FACTORY, NEWARK, N. J.



**JOHN N. DISSELKOEN,**  
Gutter and Importer of  
**DIAMONDS**  
FACTORY  
78 LANGEBLEEKERSPAD,  
AMSTERDAM.  
19 East 16th St.,  
NEW YORK.

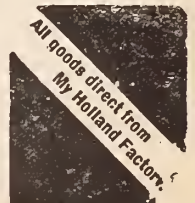

# CLASSIFIED INDEX TO ADVERTISEMENTS.

All Advertisements are entitled to one insertion under proper heading. Extra insertions, \$6.00 per annum.  
Extra Headings, \$12.00 per annum.

	Page.		Page.		Page.
<b>Art Pottery, Bric-a-brac, Etc.</b>		<b>Gold Jewelry.</b>		<b>Silver Plated Ware.</b>	
Bing, Ferdinand & Co., 106 Grand St., N. Y. . . . .	38	Aikin, Lambert & Co., 19 Maiden Lane . . . . .	43	Pairpoint Mfg. Co., New Bedford, Mass. . . . .	5
Bradley & Hubbard Mfg. Co., Meriden, Conn . . . . .	42	Carter, Sloan & Co., 15 Maiden Lane, N. Y. . . . .	27	Rogers & Bro., 16 Cortlandt St., N. Y. . . . .	11
Straus, L. & Sons, 42 to 48 Warren St., N. Y. . . . .	37	Cross & Beguelin, 17 Maiden Lane, N. Y. . . . .	7	The Wm. Rogers Mfg. Co., Hartford, Conn. . . . .	12
<b>Assayers &amp; Refiners.</b>		Hedges, A. J. & Co., 6 Maiden Lane . . . . .	7	Webster, G. A., Chicago, Ill. . . . .	33
Goldsmith Bros., 63 & 65 Washington Chicago, Ill. . . . .	32	<b>Gold and Silver Novelties.</b>		<b>Sterling Silver Novelties.</b>	
U. S. Smelting & Refining Works, 25 John St., N. Y. . . . .	44	Riley, John A., & Sloan Co., Ltd., Broadway and 17th Street. . . . .	5	Codding Bros. & Heilborn, North Attleboro Mass. . . . .	37
<b>Auctioneers.</b>		Waite, Thresher Co., Providence R. I. . . . .	4	Holmes & Edwards Silver Co., Bridgeport, Conn. . . . .	24
Boyle, Davis & Goodman, 63 5th Ave., N. Y., 611 Pennsylvania Ave., Washington, D. C. . . . .	38	<b>Horological Schools.</b>		Hagan, White & Co., 243 W. 23d St., N. Y. . . . .	40
Comrie, A. J., 22 John St., N. Y. . . . .	37	Parson's School for Watchmakers, Peoria, Ill. . . . .	31	Kent & Stanley Co., Providence, R. I. . . . .	8-9
H. M. Rich & Co., 21 School St., Boston, Mass. . . . .	37	Philadelphia College of Horology, 623 Heed Building, Phila., Pa. . . . .	29	Provenzano, J. N., 39 Union Square, N. Y. . . . .	12
<b>Badges, Medals, Etc.</b>		<b>Insurance.</b>		Richardson, Enos. & Co., 23 Maiden Lane. . . . .	37
Stockwell, E. R., 19 John St. N. Y. . . . .	40	Fidelity & Casualty Co., 140-146 Broadway. . . . .	38	<b>Sterling Silverware.</b>	
<b>Book Marks, Sterling Silver and Gold.</b>		<b>Jewelry, Silverware and Optical Cases.</b>		Fuchs, Ferd. & Bros., 808-810 Greenwich St., N. Y. . . . .	29
Stone Bros., 535 Broadway, N. Y. . . . .	12	Steinhaus, T. C., 10 Maiden Lane, N. Y. . . . .	37	Knowles, J. B. & S. M. Co., Silversmiths' Hall, Union Square, N. Y. . . . .	40
<b>Carborundum.</b>		<b>Jobbers, Watches, Diamonds, Etc.</b>		Towle Mfg. Co., Newburyport, Mass. . . . .	38
The Carborundum Co., Monongahela, Pa. . . . .	43	Allen, Benj. & Co., Chicago, Ills. . . . .	31	Reed & Barton, 37 Union Square, N. Y. . . . .	20
<b>Chains.</b>		Aikin-Lambert Jewelry Co., 19 Maiden Lane. . . . .	42-43	Shiebler, G. W. Co., 179 Broadway, N. Y. . . . .	26
Kent & Stanley Co., Providence, R. I. . . . .	8-9	Brethauer Watch and Jewelry Co., Chicago, Ill. . . . .	33	Wallace, R. & Sons Mfg. Co., 3 Park Place, . . . . .	6
<b>Clocks, French, English and American.</b>		Myers, S. F. & Co., 48 Maiden Lane, N. Y. . . . .	44	Wood & Hughes, 16 John St., N. Y. . . . .	29
Jacques, Chas., Clock Co., 22 Cortlandt St., N. Y. . . . .	44	<b>Musical Boxes.</b>		<b>Tortoise Shell Goods.</b>	
Self-Winding Clock Co., 26 Broadway, N. Y. . . . .	44	Cuendet, E. L., 21 John St., N. Y. . . . .	7	Potter, W. K., Providence, R. I. . . . .	5
<b>Cut Glass.</b>		Jacot & Son, 39 Union Square, N. Y. . . . .	37	<b>Tool Manufacturers and Dealers.</b>	
Clark, T. B. & Co., 860 Broadway, N. Y. . . . .	24	<b>Ophthalmic College.</b>		Allen, Benj. & Co., Chicago, Ill. . . . .	3
<b>Diamond &amp; Precious Stone Importers.</b>		St. Louis Ophthalmic College, St. Louis, Mo. . . . .	33	American Watch Tool Co., Waltham, Mass. . . . .	16
Cottier, C., & Son, 14 Maiden Lane, New York . . . . .	44	Chicago Ophthalmic College, Chicago, Ill. . . . .	31	Moseley & Co., Elgin, Ill. . . . .	31
Disselkoeen, John N., 19 E. 16th St., N. Y. . . . .	27	<b>Optical Goods.</b>		Mossberg Wrench Co., Attleboro, Mass. . . . .	40
Falkenau, Oppenheimer & Co., 40 Maiden . . . . .	44	Geneva Optical Co., Chicago, Ills. . . . .	31	Oliver, W. W., Buffalo, N. Y. . . . .	44
Hedges, Wm. S. & Co., 170 Broadway, N. Y. . . . .	26	Queen & Co., Philadelphia, Pa. . . . .	12	<b>Trunks and Traveling Bags.</b>	
Kahn, L. & M. & Co., 172 Broadway, N. Y. . . . .	44	<b>Pens, Pencils, etc.,</b>		Crouch & Fitzgerald, 161 Broadway, N. Y. . . . .	26
Keller, Ettinger & Fink, 24 John St. . . . .	26	Aikin, Lambert & Co., 19 Maiden Lane, N. Y. . . . .	42-43	<b>Watch Manufacturers.</b>	
Kipling, R. A., Hays Bldg., N. Y. . . . .	26	<b>Photo-Miniature.</b>		The E. Howard Watch and Clock Co., 41 Maiden Lane. . . . .	2
Randel, Baremore & Billings, 29 Maiden Lane . . . . .	27	Favre Leon, 107 East 26th St., N. Y. . . . .	44	Trenton Watch Co., Trenton, N. J. . . . .	13
Smith, Alfred H. & Co., 182 Broadway, N. Y. . . . .	26	<b>Ring Makers.</b>		<b>Watch Case Manufacturers.</b>	
Tannenbaum, L., & Co., cor. Maiden Lane and Nassau St., N. Y. . . . .	23	Bowden, J. B. & Co., 192 Broadway, N. Y. . . . .	16	Wadsworth Watch Case Co., Newport, Ky. . . . .	
<b>Diamond Cutters.</b>		Bryant, M. B. & Co., 10 Maiden Lane, N. Y. . . . .	42	<b>Watch Case Repairers.</b>	
Fox Bros. & Co., 68 W. 4th St., Cincinnati, O. . . . .	34	<b>Safes.</b>		The Planchamp & Becker Co., Chicago, Ill. . . . .	31
Oppenheimer Bros. & Veith, 35 Maiden Lane, N. Y. . . . .	14	Mosler, Bahmann & Co., 518 B'way, N. Y. . . . .	37	<b>Watch Importers.</b>	
<b>Diamond Polishing Mills.</b>		<b>Sample Trunks.</b>		Hyde's, J. E., Sons, 22 Maiden Lane, N. Y. . . . .	40
Arthur Co., The, 86 John St., New York. . . . .	19	Crouch & Fitzgerald, 161 Broadway, N. Y. . . . .	26	Mathey Bros., Mathez & Co., 21 & 23 Maiden Lane, N. Y. . . . .	19
<b>Fine Stationery.</b>		<b>Show Cases.</b>		Racine, Jules, 180 Broadway, New York. . . . .	43
Parsons & Greene Co., 18 Murray St., N. Y. . . . .	5	Smith, B. & W. B., 220 W. 29th St., N. Y. . . . .	44	<b>Watch Keys.</b>	
<b>Gold and Rolled Plate Jewelry.</b>				Clark, A. N., Plainville, Conn. . . . .	44
Foster & Bailey, Providence, R. I. . . . .	3				



## Special Notices.

Rates 75c. per insertion for notices not exceeding 3 lines (25 words); additional words 2 cents each. If answers are to be forwarded, postage stamps must be enclosed. Two insertions, 15 per cent. off; three insertions, 20 per cent. off; four insertions or more, 25 per cent. off. Payable strictly in advance. Display cards on this page will be charged at \$2.00 per inch for first insertion, subject to same discount as above for subsequent insertions.

Under the heading of **Situations Wanted** on this page advertisements will be inserted for **One Cent a Word**. This offer refers to **Situations Wanted only**. Payable strictly in advance. If answers are to be forwarded, postage must be enclosed.

## Situations Wanted.

*Notices under this heading ONLY are charged at one cent a word, payable strictly in advance. If answer are to be forwarded, postage must be enclosed.*

**BOOKKEEPER**, absolutely reliable and competent to take charge of office, credits and collections, desires to make a change; for number of years in similar position in watch and diamond line; excellent references. Address Amiable, 170. Care JEWELERS' CIRCULAR.

**POSITION** desired by young man of good address and ability, where 12 years' business experience and acquaintance with New England, Middle States, and southern jewelry trade will enable him to advance; highest references. W. A. L. S., P. O. Box 1276, New York.

**SALESMAN**.—A first-class man, with unquestionable references as to ability, character, &c., direct from one of the largest houses in N. Y. city, desires an engagement to travel in New England, New York city and near-by towns. Would like line of fine gold jewelry or any manufacturer's line. H. J., JEWELERS' CIRCULAR.

**WANTED**, a position as salesman, after Jan. 1st, in a wholesale or retail jewelry business, by one who is at present engaged with one of the leading jewelry firms in this city. Best of references given. Address A. A. X., care JEWELERS' CIRCULAR.

**SITUATION** wanted by experienced jeweler and engraver. A1 reference; fine tools; east preferred. Address B. A. Martin, Jefferson, Ohio.

**WANTED**, by a practical jeweler. Experienced foreman and designer, especially diamond work. Wishes a position by Jan. 1st. Address A. B., care JEWELERS' CIRCULAR.

**SITUATION** as traveling salesman to call on the retail jewelry trade; 9 years experience as watchmaker and salesman. Best references. Address 24, care JEWELERS' CIRCULAR.

**YOUNG MAN** wishes position in wholesale house; 3 years' experience in the retail business. Can give first-class references. E. H., 1095 3d Ave.

**TO MANUFACTURERS**.—Situation wanted as traveler; either silver goods or gold jewelry. Ten years' experience in retail store. References. Address B. D. S., care JEWELERS' CIRCULAR.

**WANTED**, to finish trade, 3 years' experience. Best of references. Address T., care of John Burgess, Bloomfield, Iowa.

**SITUATION WANTED** by first-class watchmaker and engraver, competent to take full charge. Address 120 Pearl St., Painesville, Ohio.

**WANTED**, situation by young man as engraver and assistant watchmaker; good in general about a jewelry store. Sober and industrious. Address M. A. C., care of JEWELERS' CIRCULAR.

## Help Wanted.

A **TRAVELING** salesman to handle a first-class line of jewelry on commission in New York State, Pennsylvania, Ohio, or any one or two of the three, calling on the legitimate jewelry trade only in connection with his present line. Address T. 74, care JEWELERS' CIRCULAR.

**WANTED**—Letter engravers on silverware. State experience and wages expected. Address B. C., care JEWELERS' CIRCULAR.

**WANTED**, first-class designer on silver novelties. Send references, stating salary expected. Address B. & Co., P. O. Box 160, Providence, R. I.

**WANTED**, good engraver, who can assist watchmaker when not busy engraving, for leading store in the southwest. Address, giving age and salary wanted, S. Charles, P. O., Memphis, Tenn.

**WANTED**, a first-class salesman acquainted with clock trade in New England, Western, Middle or Southern States. Address with references, F. W. M., care JEWELERS' CIRCULAR.

## For Sale.

**FOR SALE**—Tools, fixtures and machinery of a manufacturing jeweler; can be seen in working order. Address King & Co., 355 Mulberry St., Newark, N. J.

A **RARE** opportunity for the purchase of a first-class jewelry and optical business in Asbury Park, N. J., the world-famed seaside resort; the long-established business of H. Schmidt, deceased, at No. 639 Cookman Ave. including stock, safe, fixtures, tools and materials is offered for sale; the location possesses unsurpassed advantages for a splendid investment. For full particulars address S. A. Patterson, Administrator, care JEWELERS' CIRCULAR.

**FOR SALE**.—New Weiland optometer, new ophthalmoscope placido disc, telegraph key and sounder, astronomical telescope, fine violin, marine chronometer and watch adjuster's oven. All in good working order. Write for particulars and prices, S. Richards, South Paris, Maine.

## Miscellaneous.

**WANTED TO RENT**—Suitable accommodations with at least three windows for diamond cutting, power and good light indispensable; location in or near Maiden Lane or John St.; rent about \$30 a month. Address "Diamond Cutter," care JEWELERS' CIRCULAR.

**WANTED**—If any one has a new patent article in silver novelties or a new design of ladies' or gents' chains, please communicate with P. O. Box 160, Providence, R. I.

**TO OPTICIANS**.—I am the originator of several optical illusion cards which are trade winners. Only sold to one optician or jeweler in each town or city. Prices to the trade on application. First come, first served. Wm. M. Updegrave, 242 Main St., Johnstown, Pa.

**WANTED**—Second hand balance for gold; capacity 300 ounces each pan. Address V. S. M., care JEWELERS' CIRCULAR.

**I BUY JEWELRY STOCKS**—Manufacturers, jobbers and retailers desiring to dispose of surplus or entire stocks of diamonds, watches and jewelry, can find quick cash buyer by addressing Oscar Langer, 176 Broadway, Room 58½, or 223 E. 71st St., New York.

## WHEEL CUTTING.

We make a specialty of Wheel Cutting, Demagnetizing and Watch Repairing for the trade. Complete plant. Send for price list.

**THE WINSLOW & PENNEY CO.**  
608 Masonic Temple, CHICAGO.

**WOOD & HUGHES.**  
**STERLING SILVERWARE MANUFACTURERS**  
New York Agents for the Derby Silver Co.  
**FINE QUADRUPLE PLATED WARE,**  
No. 16 JOHN STREET, NEW YORK  
206 Kearney St., San Francisco, Cal.  
**HASKELL & MUEGGÉ, Agents.**

## Philadelphia College of Horology

Is not the largest but is the finest school in the country. A practical school to learn watch-making, engraving, and jewelry repairing. One tuition pays for all branches. Send for prospectus.

**F. W. SCHULER, PRINCIPAL.**  
1213 Filbert St., Philadelphia, Pa.  
Write for particulars of our corresponding course.

## THE VALUE OF

# The Jewelers' Circular

AS EXPRESSED IN

## Unsolicited Testimonials.

Enclosed find \$2 for another year's subscription to your valuable journal. Long live THE JEWELERS' CIRCULAR is the wish of  
CHAS. TUCKER, Del Norte, Cal.

As soon as our subscription is out, we shall renew it. We shall take THE CIRCULAR as long as we are in business.

MARKS & KRANK, Schenectady, N. Y.

THE CIRCULAR has been visiting me monthly and weekly for the past 18 years.

H. H. ROBINSON, Presque Isle, Que.

It is *the* live jewelers' paper and keeps us in touch with the trade throughout the continent. We want it if only for the advertisements.

BRITTON BROS., Lindsay, Ontario.

We think it pays to keep posted. We read our CIRCULAR and find it to be one of our very useful helps.

BROWN, HIXON & Co., Lockport, N. Y.

THE CIRCULAR has been the means of saving me considerable money in the last three years in buying goods from jewelers who advertise in it.

H. M. TURNEY, Goodland, Kan.

I always find THE CIRCULAR very interesting, and find many points of information in the same which have often proved to be quite valuable to me.

A. E. HAIN, Westerly, R. I.

Think each article you publish about "Window Decoration" worth the full price of your subscription, and trust you will have more of them this year.

GEO. E. FEAGANS,  
Joliet, Ill.

Subscription Price \$2.00 per Annum.

**FERD. FUCHS & BROS.**  
**SILVERSMITHS,**  
MAKERS OF STERLING SILVERWARE,  
808-810 Greenwich St., New York.

"THE FUTURE WESTWARD TAKES ITS WAY"

# WESTERN SUPPLEMENT

## of THE JEWELERS' CIRCULAR

**Chicago Office: Room 517, Inter-Ocean Building.**

VOL. XXIX.

CHICAGO, WEDNESDAY, DEC. 19, 1894.

NO. 21.

### Chicago Notes.

#### TRADE CONDITIONS.

Work every night to midnight is the record for the week among leading jewelry establishments. Business is also picking up very nicely with the down-town retailers. Representatives of eastern houses who have stocks here are finding good orders from leading retailers, but those without the goods for immediate delivery are finding little business, the stores not being willing to delay filling stocks even for the few days' time necessary to secure the filling of orders from the east. Retail city trade in out-lying districts are stocking up a little in anticipation of a rush just before the holidays, but trade with them at present is quieter than is usual at this season. This is probably due in part to the sales of misrepresented goods by some of the department stores, as, for instance, the sales of advertised "gold-filled" cases, which are only plated trash—methods which a legitimate jeweler would not sanction.

Manufacturing jewelers are taking on new customers, and business is rushing on fine work. On this class Juergens & Andersen Co. have 105 men employed, the largest number they ever placed at benches, and the men work till 10 p. m., nightly.

In the natural order of things the clock business should show a decline; on the contrary, this branch is maintaining its high standard of sales with all houses very busy.

Engravers have more work than they know what to do with. Not so many watch cases and high priced goods, but floods of silver articles.

The season for gold pens, so far as manufacturers are concerned, is about over, but small orders are still numerous. The Fall season in this line has been exceptionally good.

Diamond sales are generally for the smaller stones, and single stones rather than expensive pieces.

Towle Mfg. Co. report more goods sent out in both November and December than ever before for these months.

The Illinois Watch Case Co. have certified to an increase in capital stock from \$50,000 to \$250,000.

P. H. Lachicotte & Co., Columbia, S. C., have added to the jewelry stock a fine line of art goods, porcelain and cut glass.

Mr. Woodworth, buyer for T. F. Swan, Elgin, a prominent crockery house, was in the city last week buying silverware.

A. L. Sercomb, manager of the Chicago house of the Meriden Britannia Co., returned Monday last from a visit to the factory.

Arthur Holly, formerly with the Towle Mfg. Co. here, and now eastern traveler for the factory, is spending the week at the Chicago house.

The Treleaven Optical Co., of Chicago, have incorporated: capital stock, \$30,000; incorporators, Walter N. Treleaven, Geo. M. Stannard, Thomas S. Jackson.

Correll & Bro., Spartanburg, S. C., have moved into their new store on the main street of that city and have branched out quite considerably in the way of increased stock.

G. A. Webster, 44 Madison St., reports the shipments made by his house the past week were more than double those of any previous week since the Chicago house was established.

Harry Howard: "Business continues excellent. Our clock business was never better and I think it will exceed that of the largest week we ever had, in tower, electric, watchman, and wall clocks."

Manager Rich, of Alfred H. Smith & Co.'s Chicago house, states the month so far shows a considerable increase in diamond sales over a year ago with prospects excellent for a continued increase up to the first of the year.

At Kinsley's, Jan. 24, was the decision reached Thursday by the banquet committee of the Chicago Jewelers' Association, as to place and time for having their feast of good things, intellectual and gastronomic. The committee are hard at work perfecting details and declare the intention to make the banquet the most successful of any yet held by the Association.

The charity ball of the Young Men's Hebrew Association, held at the Auditorium Dec. 11th, was the most brilliant success from a social and financial standpoint of any held since the inauguration of the club. In the past fifteen years the association has distributed \$150,000 to charitable institutions without regard to creed and the function of Dec. 11th cleared \$20,000 for this purpose. Instrumental in the success of the charity ball was the following well known jewelers: Messrs. and Mesdames H. F. Hahn, Louis Manheimer, M. S. Fleishman, M. H. Berg, Frank Lewald, Sol Kaiser, Ed Hyman; Messrs. Will Manheimer, R. A. Kettle, John M. Cutter, M. Loeb.

Near-by jewelers were well represented here the past week, with a fair sprinkling of those from neighboring states. Included in the number represented here were: D. W. Bratton, Brazil, Ind.; J. E. Haep, Montpelier, Ohio; James Gilkowski, Milwaukee, Wis.; Mr. Davenport, buyer for C. P. Dunbar, Wausau, Wis.; Arthur Jackson and wife, Eau Claire, Wis.; Mr. Smith, Madison, Wis.; M. V. Cole, Michigan City, Ind.; Mr. Lough, Buchanan, Mich.; J. S. R. Scoville, Fort Madison, Ia.; C. S. Sands, Cedar Rapids, Ia.; E. W. Kelley, Sullivan, Ind.; Fred. Eynatten, Peoria, Ill.; C. J. Linden, Kankakee, Ill.; Mr. Volkman, Kankakee, Ill.; W. Kennedy, Leland, Ill.; E. Knodle, Bairdstown, Ohio; M. Luchtemeyer, Blue Island, Ill.; Albert Miller, Dundee, Ill.; C. J. Peterson, St. Charles, Ill.; P. Pfeiffer, Lemont, Ill.; J. H. Rogers, Gridley, Ill.; Mrs. F. J. Reemer, South Chicago, Ill.; Skewis & Martin, Scales Mound, Ill.; J. R. Schneider, Evanston, Ill.; J. M. Scribner, Attica, Ind.; G. I. Schaefer, Morton, Ill.; J. G. Bodenschatz, Lemont, Ill.; L. M. Bird, Aurora, Ill.; L. H. Bauer, Elgin, Ill.; L. Buysse, South Bend, Ind.; H. Appelbaum, Lemont, Ill.; W. W. Denny, Aurora, Ill.; Mrs. E. E. Dame, Reedsburg, Wis.; C. E. Dodge, Walnut, Ill.; Eggerman & Son, Aurora, Ill.; J. F. Ingalls & Son, Waukegan, Ill.; A. S. James & Co., Ely, Minn.; Young & Hamilton, Cissna Park, Ill.; W. P. Yeoman, Waukegan, Ill.; Mr. Baird, Farmington, Ill.

# LOOK AT THESE PRICES!

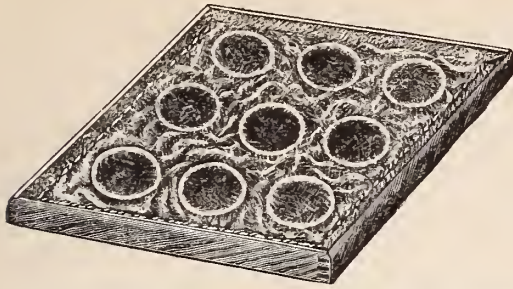

Show Case Trays with Solid Walnut Frames lined with Fine Red Silk Plush, with Old Gold Border, and made to stack one on top of the other. Size, 11 3/4 x 11 3/4.

For Gents' Watches, each . . . . . \$1.25  
For Ladies' Watches, each, . . . . . \$1.25  
For Rings, each . \$1.25. For Chains, each, . \$1.25  
For Charms, ea., \$1.25, for Card Jewelry, plain, ea., 80c.

Subject to the usual discount for cash.

## CHRISTMAS IS COMING.

Make your Stock Attractive and Fresh. It does not cost much and will add largely to your SALES.

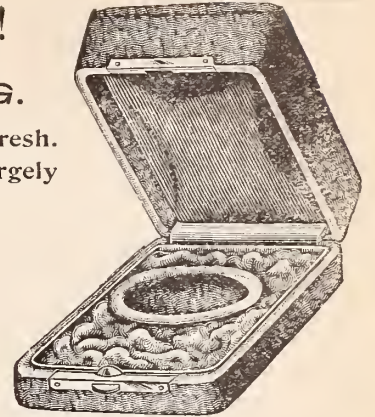

### FINE PLUSH BOXES.

For Gents' Watches, per dozen, \$3.00  
For Rings, per dozen, . . . . . \$2.00  
For Six Tea Spoons, per dozen, \$9.00  
For Child's Set, per dozen, . . . . . \$9.00  
For Sugar Shell, per dozen . \$9.00  
For Ladies' Watches, per dozen, \$3.00  
For Ear Drops, per dozen, . . . . \$3.50  
For Six Table Spoons, per dozen, \$15.00  
For Six Coffee Spoons, per doz., \$15.00  
For Butter Knife, per dozen, . \$9.00

Subject to the usual discount for cash.

WATCHES, CLOCKS,  
DIAMONDS,  
SILVERWARE  
and JEWELRY.

## BENJ. ALLEN & Co.,

141 & 143 State St.,

CHICAGO, ILL.



## GENEVA OPTICAL CO., CHICAGO.

CATALOGUES.

- PART 1—General Catalogue of Optical Goods.
- " 2—Microscopes and Accessories.
- " 3—Photographic Cameras, Stocks and Supplies.
- " 4—Thermometers, Barometers and Meteorological Instruments.

**PRESCRIPTION WORK** Made with Promptness and Accuracy.

**OCULISTS' or OPTICIANS' OUTFITS.** Trial Cases. Ophthalmoscopes. Lens Measures.

CORRESPONDENCE SOLICITED.

DON'T FORGET THE JEWELERS' CIRCULAR PUBLISHING CO.'S BOOK LIST when in want of any technical book in the Jewelry or Kindred Trades.

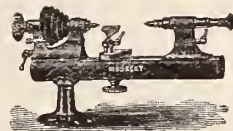

One of the best of the very best.

QUALITY IS THE STANDARD OF VALUE FOR WHICH WE COMPETE

### "THE MOSELEY."

"A Bread Winner" for the watchmaker. We furnish you good lathes and chucks, while the other fellow furnishes the wind.

MOSELEY & CO., Elgin, Ill.



No. 2 Moseley Wire Chuck has length, strength, accuracy.

## PARSONS & SCHOOL —FOR— WATCHMAKERS, PEORIA, ILL.

Send for Circular and Terms.

PARSONS & CO.

## THE PLANCHAMP & BECKER CO. Makers and Repairers of

### WATCH CASES,

Gold and Silver Plating — of Watch Cases a Specialty.

UNEXCELLED FACILITIES.

43 and 65 East Washington St., Chicago.



## OPTICIANS' SCHOOL.

If you want a GOOD ROOF over your head, come to our school. We want EARNEST STUDENTS, leave the rest to us, we do not want diploma hunters.

The Chicago Ophthalmic College and Hospital,

H. M. MARTIN M.D., PRESIDENT. 607 VAN BUREN ST., CHICAGO

Being the oldest and most favorably known College of Theoretical and Applied Ophthalmic Optics in America, having more thoroughly qualified theoreticians in the field than all other so-called schools combined.

# THE WADSWORTH WATCH CASE CO.



774.

General Offices,  
NEWPORT, KY.

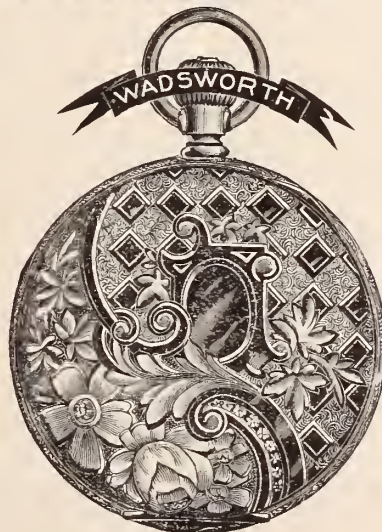

793.

NEW 12 SIZE  
TO FIT ALL 6S. P. S. MOVEMENTS.

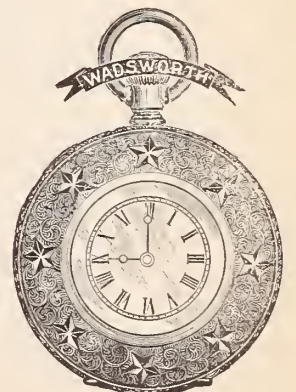

802.

Chicago Office,  
COLUMBUS BUILDING.

Filed

Cases.

**San Francisco.**

G. Neff has returned to Virginia City.

E. C. Marhave, of Phelps & Miller, has left for the north.

E. B. Dana, of Carter, Sloan & Co., New York, was in town recently.

E. M. Levy will, the first of the year, locate permanently in Chicago.

E. H. Lowenthal has returned from a very extended trip for Eisenberg & Co.

Louis Levison, a retired member of Levi-son Bros. & Co., will return shortly to Europe.

Emile Quarre has sold out his jewelry stock at 120 Sutter St., and has gone out of business.

F. A. Jeanne, of Alfred H. Smith & Co., New York, left last week on the Sunset limited for New Orleans.

John Fry, Vallejo; H. Wachhorst, Sacramento; Peter Engle, Marysville, were in town last week buying goods.

Geo. E. Powell and R. G. Bonestell, of the California Jewelry Co., have returned from trips in the interior.

M. Wunsch has been rusticated for a few days. Richard Walsch, of M. Wunsch & Co., has returned from the south.

"The Max Shirpsler Jewelry Store," 910 Market St., has just been opened. This makes four stores that are now being run in this city by Henry Meyer. C. Radke is manager.

The American Watch Co. have incorporated with a capital stock of \$1,000,000 with the following directors: Chas. Bourne, Percie H. Coward, A. H. Ste. Marie, F. Spangenberg and G. De Luca.

W. S. Binney, of Amsterdam, Holland, has arrived in this city from the east. He is a diamond polisher by trade and says he has come to the coast for the purpose of locating. He thinks San Francisco a good field for his business.

**Pacific Coast Notes.**

F. M. Judd has opened a jewelry store on 7th St., Medford, Ore.

H. W. Bernheim, Napa, Cal., is suffering with pleuro-pneumonia.

Mr. Rodie, a jeweler of Cleveland, O., will settle with his family in El Cajon Valley, Cal.

A. J. Davidson has purchased the stock of the Gem Jewelry Store, Elko, Nev., and will hereafter conduct the business in his own name.

The new jewelry store of M. Lissner & Co., Broadway and 13th St., Oakland, Cal., opened with eclat. It is one of the finest stores in appearance on the coast.

G. W. Hastings, Santa Cruz, Cal., is to retire from the jewelry business and to engage in teaching music. Mr. Hastings is leader of one of the best brass bands in the State.

Irwin Runyeon, formerly of Reading, Pa., has opened in Redlands, Cal., where he will carry a stock of gold jewelry exclusively. Mr. Runyeon, is a graduate of the Parsons & Co.'s watchmakers' institute, Peoria, Ill.

Two men were arrested in San Bernardino, Cal., recently, on suspicion of being diamond thieves. One of them had sold the mountings of jewelry to a jeweler and later the other one attempted to dispose of \$1,000 worth of diamonds to another dealer.

Representatives of London capitalists have, for some time, been investigating Utah onyx properties, with the result of a company being organized at Ogden. The company will undertake to erect cutting and polishing works in that city. Utah onyx is found in pieces as large as six feet square. The officers of the new company will probably be Daniel Harner, president; F. S. Brereton, treasurer, and Dr. Geo. F. Phillipis, secretary.

C. D. Platt, the Los Angeles jeweler who has spent several months in jail is at liberty, and that without trial, or at least a second trial. His case came up for a second trial some days ago and the United States District Judge ruled that the indictment was defective, in that it did not charge that Platt and his alleged co-conspirator, Harris, conspired to fraudulently use the mails, and anything short of this was not a crime under the laws defining

# NOW IS THE TIME . . .

To look over your old style and unsalable jewelry, old plated jewelry, filings, sweeps, etc  
You want to put your stock in good shape for the holidays. The question is:

"Where shall I send my old gold and silver?"

Remember, that we pay 4c. per kt. for Gold and Highest Market

## Prices for Old Silver.

There is a well known maxim that "Experience makes perfect." To accurately test and value a lot of old gold, etc., the requisite experience is absolutely necessary. Being the largest buyers of old gold and silver in the country, and having the exclusive patronage of the majority of the jewelers in the United States and Canada, we can guarantee to the trade accuracy in valuation and

**PROMPT AND HONEST RETURNS.**



## OUR PLAN

Immediately upon receipt of shipment we will remit by cash or draft (as desired). If our offer should not prove satisfactory, we will return consignment in exactly same condition as received, and pay all charges. By this arrangement you are absolutely safe, as it is no sale unless our offer should prove satisfactory, and you run no more chances than if you were disposing of same right over your counter.

## GOLDSMITH BROS.,

Mention the Jewelers' Circular.

Gold, Silver and Platinum Refiners and Assayers,

**FREE**—Send for our LITTLE BOOK giving pointers on preparing acids, testing and buying gold, etc., mailed free on application.

63 & 65 Washington St., Chicago, Ill.

conspiracy. There is still a charge standing against Platt but it is thought this will not now be pressed.

Charles Niner, Santa Maria, Cal., has moved into enlarged quarters.

Robert Collingwood, late of Elmira, N. Y., has opened a jewelry and optical store in Pasadena, Cal.

The Trigg Jewelry Co., Albuquerque, N. M., have been appointed to schedule the stock of the insolvent jeweler, M. C. Nettleton, and the assets are not at present known.

The Common Council of Los Angeles have prohibited the opening of any saloons on "Jewelers' Row," this being the name given to a certain block on Spring St. on which a number of jewelers are congregated.

A crowd of tramps nearly wiped out the jewelry store of H. L. Williams, in Glendora, near Los Angeles. They looted a general merchandise store and a bakery, besides the store of Mr. Williams. They took a quantity of clocks and cheap jewelry.

George Steele, whose body was found in the Sacramento River, as reported in THE CIRCULAR last week, was a traveling salesman for the Standard Jewelry Co., San Francisco. Steele committed suicide by jumping from the deck of the steamer *J. D. Peters*. He was without means and had of late been unsuccessful on the road.

### Columbus, O.

A. A. Gerlach, the past week, issued a writ of replevin to recover a 2½ karat diamond stud, which he claims was stolen from his store.

E. H. Fisher, jeweler of Elyria, has caused the arrest of J. W. Voglesang, for alleged assault. Voglesang objected to some epithet applied by Fisher and leaning over the jeweler's counter attempted to strike him. Voglesang filed a counter charge against Fisher, alleging provocation. The affair created considerable excitement as both parties are well-known.

Elyria officers received word that the jewelry stolen from Fisher's store at Lorain, recently, was hidden in a corn shock, north of town, one night last week. In company with Constable Boyd, Sheriff Ensign went to the spot and laid in wait. About 8 o'clock seven men showed up and the officers attempted to make an arrest. Two of the men opened fire. Officer Boyd received a bullet in the leg. He and the sheriff emptied their revolvers into the crowd, which broke and ran. One colored man named Ward was arrested, but the rest escaped. A satchel and two guitar cases full of jewelry were found.

### Rockford.

F. Klingstedt has moved his jewelry business to 630 7th St.

L. T. Fenning is again in the jewelry business and is with N. E. Benoit.

Burglars a few days ago attempted to rob the jewelry store of F. Dahlberg, at

Durand, but were foiled. No arrests were made.

### Detroit.

A. F. Limbright, the Flat Rock jeweler, lost his father by death at Wyandotte recently.

Valentine Jacobi, 156 Antoine St., last week gave a chattel mortgage for \$200, to William C. Arndt.

The Southbridge Optical Co. last week obtained a judgment against the United States Optical Co., for \$2,620.24.

M. D. Walton, Armada, Mich., purchased goods here last week. Mr. Walton has new quarters in the Masonic Block recently constructed at that place.

Eugene Kingman, of G. A. Dean & Co., spent last week here introducing Mr. Richardson who will cover this territory hereafter. It was Mr. Kingman's last trip.

D. D. Shaene, Grand Lodge, recently purchased the jewelry stock of Mr. Moore, Clarkston, Mich. He will place the same under the management of Fred Taber, who is a graduate of a Chicago optical school.

Referring to item under Detroit in issue of December 5th, referring to Roehm & Son, the check spoken of was cashed by their book-keeper for a friend of another employe. The firm had no connection with it whatever. The employe who guaranteed the check to the book-keeper has received the amount from relatives of Mr. Ferguson.

The retail stores of this city were last week crowded with customers and the prospects are for a very satisfactory Christmas trade. All the Detroit stores will remain open in the evening until after the holidays. The jobbers while not as busy as in former seasons are enjoying a better trade than was expected. Mail orders are heavy and traveling salesmen are sending in generous bills from the country trade. Among the Michigan country jewelers who purchased goods here last week were: J. C. Cozadd, Wayne; George H. Chapel, Howell; J. S. McLachlan, Wyandotte; H. St. John, Milford; G. W. Stephens, Port Huron; H. W. Kludt, Lennox; William Gribin, Carsonville; Mr. Nichols, Saline; Mr. Rogers, New Haven; Eugene Wagner, Monroe; George Carhart, Pontiac; A. L. Gregory, Lapeer; and W. L. Becker, Broughton.

### Kansas City.

E. S. Marks, with Hugh Oppenheimer & Co., came in last week, but immediately left for southern Kansas for a short holiday trip.

B. Hyman, Hirsch & Hyman; F. R. Horton, Carter, Sloan & Co.; and Henry Jacobson, Jacobson Bros., were in town the past week.

Geo. L. Brenning, with the Dennison Mfg. Co., was here last week. He is one of the best known salesmen on the road and has many friends here.

J. H. McDonald, Garden City, Kan., has absconded. He suddenly left, giving no notice and leaving nothing except a number of debts and a little of his jewelry stock. J. A. Norton & Son, wholesale jewelers of this city, are the principal losers.

A chattel mortgage for \$5,600 has been given by A. L. Hosmer to Susan P. Barrett, Johnson County, Mo. It is secured on the stock of jewelry and fixtures at 725 Main St. The store is not closed, but Mr. Hosmer is selling the goods with the consent of the holder of the mortgage and subject to the incumbrance.

Country trade was dull last week; among the country buyers in town were: Wells & Robinson, Olathe, Kan.; H. S. Huey, Excelsior Springs, Mo.; B. Hoffman, Leavenworth, Kan.; J. D. Pierson, Oak Grove, Kan.; J. H. Whiteside, Liberty, Mo.; J. P. Hale, Namego, Kan.; C. E. Warden, Namego, Kan.; and A. Z. Megeed, Norbonne, Mo.

### Indianapolis.

Until after Christmas all the retail jewelers will keep open at night. An extra force of clerks has been employed. So far the inexpensive silver novelties have met with the most ready sale. Manufacturing jewelers are all rushed with work.

Sunday morning Dec. 8th a man giving his name as John Drew kicked in the show window of H. D. Burgheim's jewelry store on S. Illinois St. He grabbed several watches and other jewelry and ran. Two

## G. A. WEBSTER

42 & 44 Madison St., Chicago, Ill.  
**Manufacturer,**  
 AND WESTERN AGENT FOR  
 E. G. WEBSTER & SON, of Brooklyn, N. Y.  
 A. F. TOWLE & SON CO., of Greenfield, Mass.

—17 Jewel Dueber-Hampden Watches—  
 ARE THE MOST RELIABLE WATCHES MADE.  
 A FULL LINE OF DUEBER CASES AND HAMPDEN MOVEMENT.  
 Write for New Price List.  
**Brethauer Watch and Jewelry Co.,** Special Agents,  
 71 WASHINGTON ST., CHICAGO, ILLS.



## The St. Louis Ophthalmic College and Hospital

A SCHOOL OF THEORETICAL AND APPLIED OPHTHALMIC OPTICS.

1655 SOUTH JEFFERSON AVENUE,

N. W. Corner Lafayette Avenue, - - - ST. LOUIS, MO.

For the Announcement and further information, address Ignatz Mayer, M. D., President.

hours later he was arrested partially drunk.

Henry Rossier, Martinsville, Ind., has joined the benedicts.

Albert Allen has opened a new jewelry store in Elkhart, Ind.

Artes & Alt have recently succeeded C. F. Artes in the jewelry business, Evansville, Ind.

E. R. Biggs, Goshen, Ind., recently retired from business. His successors are Ralston & Kessler.

J. K. Ritter is preparing to open a jewelry store in Muncie, Ind. Mr. Ritter was in the city last week buying goods.

B. Maier, Edinburg, Ind.; J. B. Hughes, Ellettsville, Ind.; A. C. Pilkenton and W. J. Hudson, Fortville, Ind.; A. Hawkins, Noblesville, Ind.; and Fred Brown, Clayton, Ind., were in the city last week buying holiday goods.

J. W. Hudson, Fortville, lost \$250 in a fire that destroyed the building in which he was located. Dec. 11th a destructive fire broke out in the handsome Bindley Block at Terre Haute, and destroyed the business of Jacob Kern.

### Minneapolis and St. Paul.

Holiday trade with the Twin Cities jobbers has been quite satisfactory, sales being much larger than last year. The retail jewelers pronounce trade better than last year.

A. Burnstine, manager of the St. Paul Jewelry Co., St. Paul, who has for the past three weeks been confined to his bed, and who had a surgical operation performed upon him, is now said to be progressing toward good health.

Eustis Bros., Minneapolis, are busily engaged with the committee in charge of the purchase of a solid silver service for the new cruiser *Minneapolis*, furnishing them with illustrations and figuring on prices. Five thousand dollars or more is to be invested for a complete service.

Out-of-town jewelers visiting the Twin Cities the past week were: P. K. Weiser, Mankato, Minn.; M. Seewald Grantsburgh,

Wis.; John Saxine, Prescott, Wis.; Wm. Krohn, Annandale, Minn.; Mr. Day, Day & Nichols, Worthington, Minn., A. E. Madsen, North Branch, Minn.

### Cincinnati.

Gustave Fox & Co. are in the swim this season with holiday novelties.

The Wadsworth Watch Case Co. have been working late at night to fill orders.

Trade is on with a rush; every retail store is crowded this week. Jobbers are also busy.

Oskamp, Nolting & Co. are working half the night now to get off their immense lot of orders.

Homan & Co. are very busy; every express company in the city have their wagons at their door every night.

Charles Stern is able to be down to his store again, looking thin but contented. Charles Rauch has returned from the road and the other travelers will be home this week.

Fred. Steinman, representative of the estate of F. W. Gesswein, New York, who has been ill at the city hospital with typhoid fever the past several weeks, was out last week for the first time. He will leave for home in a few days.

The Cincinnati chief of police has been notified that a gang of thieves are headed this way from Chicago to work holiday crowds. Their specialty is to divide in pairs and work the jewelry stores. A circular has been issued and sent to each merchant to put him on his guard.

### Omaha.

Word has been received here lately that four robbers had been arrested in Columbus, Neb., having in their possession a quantity of jewelry identified as that taken from the Tilden jewelry store, Pierce, Neb., a short time before.

The jewelry bought of Sol. Bergman the latter part of November has been found. Dec. 13th, the sheriff of Cheyenne County, Neb., levied on a trunk addressed to Albert J. Whipple, the absconding cashier of an insolvent bank in Cranford, Neb. In the trunk was the jewelry intact.

Valuable papers throwing light on the inside settlement of the C. L. Erickson estate have turned up. A tramp was arrested in Fremont, Neb., a few days ago. On being searched, a certified copy of letters of administration in the Erickson estate before ex-County Judge Eller, of Omaha, Douglas County, were found on his person, besides a certificate of deposit for \$4,633.30 in the Union National Bank of Omaha, and a list of the jewelry taken from the bank, to the value of \$700, with many other papers in the case. The tramp, who gave the name of Petersen, would not account for the possession of these documents, but they were either stolen from the attorney in the case, or from Mrs. Erickson's house some time ago.

### Cleveland.

S. Perskey & Co., jewelers of Massillon, have made an assignment.

One of the oldest jewelry firms in the city, Welf Bros., announce a dissolution of partnership to take place on Jan. 1. The limitation of the partnership has expired for many years past at the end of every five years, but time and again it has been renewed. On Jan. 1st, 1895, the partnership will absolutely cease.

Early last Sunday morning an attempt was made to break open the safe in the jewelry store of M. Meckes, 535 Pearl St. Entrance to the store was gained through a basement door in the rear. The burglars went to work at the back of the safe and had drilled a half inch hole when they were frightened away. A kit of tools was left on the floor. The safe was filled with valuable holiday goods.

"We are having a good run of all description of wares," said Manager Walton, of the Meriden Silver Plate Co., Chicago, "Novelties are selling rapidly and standard goods are in demand. The sales will exceed last years. We ought to have a good revival of trade following the present season and look for a continual growth of healthy trade from January on, until the sales of 1891-92 are reached, if not passed."

DIAMOND CUTTERS and POLISHERS looking for desirable and permanent positions should apply direct to

**FOX BROS. & CO.,**

68 and 70 West 4th Street,

CINCINNATI, OHIO.

## MATTERS IN JEWELRY STOREKEEPING.

That this department shall prove mutually beneficial to our readers, it is desirable that the members of the trade generally communicate with THE CIRCULAR regarding any advantageous device or plan that they are utilizing in the conduction of their business.

### Advertising Pointers for Jewelers.

W. W. Thompson, jeweler, Condersport, Pa., prints on the back of his business card, a table of distances of various villages and towns from his store. The villages and towns number 52, and are within a radius of 31 miles.

F. H. Brown, jeweler, Meriden, Conn., announced recently that he would make a present of a Brownie pin to each scholar who contributed an original advertisement for his line of goods until Dec. 18. He also announced a fine prize for the best advertisement.

Strauss & Macomber, jewelers, New London, Conn., have decided to make a present of a Regina music box to some one of their customers and each purchaser of one dollar's worth at their store is given a ticket. The music box will be awarded Jan. 1.

Beneath an illustration showing seven funny little boys figuring each upon a slate, is the following announcement of H. C. Kachlein, jeweler and optician, Lafayette, Ind:

### OUR FIGURES

Are bound to astonish you. Never have we offered such Bargains in Fine Diamonds, Rings, Lace Pins, Scarf Pins, Pendants, etc. We invite personal examination of our goods.

H. F. Witherby, jeweler, Grove City, Pa., has three large pumpkins in his store window. Any person purchasing one dollar's worth of goods will be entitled to guess the number of seeds in the pumpkins before Jan. 1st. Three prizes will be given to the three persons who come the nearest guessing the number of seeds.

George Bailey, jeweler, Uniontown, Pa., has an old German bible on exhibition in his window which is something of a relic. It is the property of Rev. Alfred Ramsey, of the Lutheran church. The bible was printed in Germantown, Pa., by Christopher Saur, on Dec. 8, 1763, and is, therefore, 131 years old. It is one of the second edition of the first bibles printed in America.

### A Peculiar Ad.

MOST persons are interested in theatrical affairs; thus the following imitation

...The New and Successful Domestic Drama...

# THE HOLIDAY DISPLAY

BY STERLING, GOODE & CO.

In SIX ACTS a Week and Four Beautiful Scenes.

### CAST

OLD RELIABLE	-	J. H. STERLING	COURTEOUS (Jewelry Salesman)	JOHN JONES
PIVOT (Manager of Watch Dept.)	,	B. C. GOODE	SWEETNESS (Bookkeeper)	JESSIE BROWN
SPARKLE	(Manager of Diamond Dept.)	J. B. SLOCUM	SMILES (Assistant Bookkeeper)	JENNIE RICH
POLITE (Jewelry Salesman)		H. S. DUZEN	CHIC (the Boy)	- - - JIMMY
		B. S. ROBINSON	QUICK (the Messenger)	- - - SPIKESY

CHORUS by Enthusiastic Customers.

SCENERY showing the finest line of Jewelry, Watches, Novelties, Bric-a-Brac, Cut Glass  
ARRANGED BY J. H. STERLING.

Doors Open at 7 a.m. and Performance continues till 10 p.m.

STERLING, GOODE & CO., MANAGERS AND PROPRIETORS, 189 MAIN STREET.

of a theatrical program may prove effective as an advertisement. The cast is composed of the store force. The ad. should be set in the style of a conventional program.

### A Comprehensive Yet Petite Ad.

THE plate below is a full size reproduction of a Christmas ad. of Wilson Bros.,

## Christmas is Coming!

4000 Illustrations for 2 Cents.



Send 2-cent stamp for the largest Picture Catalogue ever issued by any retail jeweler, now nearly ready. WILSON BROTHERS, 3B Tremont Row, Boston, Mass. "The Big Clock."

Boston, Mass. We consider it striking and comprehensive, the miniature reproductions of the numerous articles being clear.

### An Attractive Window.

THE show window of I. Brush's store White St., Danbury, Conn., presented a very attractive appearance recently. Bas-reliefs on either side of the window, representing "Morning" and "Night," were enclosed in a moulding surrounded by blocks of polished marble of beautiful colors and blends. Among the different kinds of marble blocks were Italian, rosentik, Irish green and dove. Together with an artistic arrangement of jewelry and precious stones the effect was very pretty.

### Souvenirs of the Season.

Clemens Oskamp, jeweler, 175 Vine St., Cincinnati, O., makes his announcement for the holidays with a beautiful lithographed souvenir, artistic in design and execution.

From Constantin Lucius, 841 Sixth Ave., New York, is received a neat folder containing the jeweler's holiday announcement. Mr. Lucius has been in the jewelry business on the same spot since 1873.

"Sensible Shopping Suggestions for Christmas," is the title of a chic little book of 32 pages 4½x3½ inches, received from Hardy & Hayes, 529 Smithfield St., Pittsburgh, Pa. At the top of each page is a pertinent quotation from the poets. The enumeration of the stock is divided into gifts for infants and children; gifts for boys and girls; glittering gems; gifts for young ladies; gifts for young men; gifts for the father; gifts for the mother; gifts for the office; gifts for the home; cut glass; sterling silver. The little pamphlet is neatly bound, and must prove of convenience to prospective gift purchasers.

The Dayton, Ohio, *Evening Herald* of Dec. 7th, contained a flattering notice of the holiday opening of Anderton, Eberhardt & Co., jewelers, of that city.

**New Clickworks.**

ALTHOUGH there is no want of good clickworks for watches, THE CIRCULAR will nevertheless describe two new Swiss inventions which are worthy of attention by reason of their simplicity and originality. Beside this, both of them appear

click and spring are in a correct position, the click depths with sufficient force into the ratchet wheel A. It requires no further explanation to show that in the procedure of the winding, the clickspring C will comply perfectly well with its functions.

Also the clickspring of the second kind, patented by the Société d'Horologie de Langendorf, largely differs in its shape from the ordinary kind. In Figs. 2, 3 and 4, which represent the several parts of this clickwork, *c* is the clickspring, which is shaped about like a spring compass and like this is elastic; *b* the click (of the ordinary shape), and *b*<sup>1</sup> a round projection of one piece with the click and serving it as rotary point, which projects through the three-quarter plate, as shown in cross section in Fig. 3. The pivot *b*<sup>1</sup> is furnished underneath the plate, upon two opposite sides, with parallel, straight planes *b*<sup>2</sup> (Figs. 2 and 3), which are firmly embraced by the elastic arms of the clickspring *e* (see Fig. 2) Since, now, the clickspring is retained by a recess

upon the lower side of the plate, it itself will retain the click in the position necessary to permit it the required elastic motion.

If the watchmaker desires to let the mainspring of a watch furnished with this kind of clickwork run down, he must turn the click about a quarter turn from the ratchet wheel, whereby it is brought into the position shown in dotted line in Fig. 3. The two arms of the circular clickspring are by this turn still further removed one from the other, whereby they occupy the part that remained full of the pivot *b*<sup>1</sup>. In this position of the spring the click naturally remains standing until brought back to the ratchet wheel, so that the spring can again snap into the side faces *b*<sup>2</sup>. If it is desired to take out the click, it is also turned into the position of Fig. 3, after which the spring at the withdrawal of the click slides over the full part of its pivot.

A dainty novelty which is sure to become a ready seller is the Bible book mark introduced by Stone Bros., 535 Broadway, New York. A feature of this, their latest production, as may be seen in the illustration on another page, is to be found in the inscriptions, which are biblical quotations, woven in the ribbon itself. The ornaments of the mark are made both in sterling silver and gold.

FIG. 1.

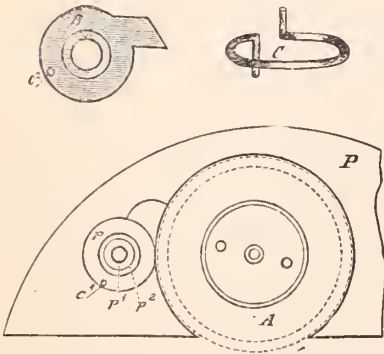

FIG. 2.

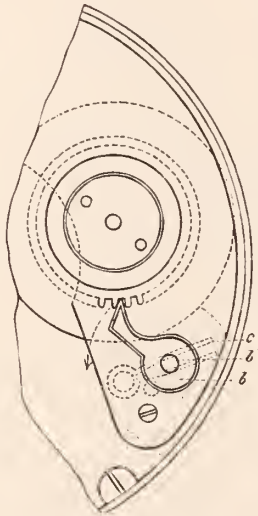

FIG. 3.

to be distinguished for the advantage that they will hardly ever break, most certainly a praiseworthy feature of a clickwork.

The essential parts of one clickwork, patented by Dubail, Monnin, Frossard & Co., of Porrentrug, Switzerland, are shown in Fig. 1; C is the clickspring; B the click; P a piece of the three-quarter plate with the ratchet wheel A shown in dotted line, and the recess *p* for the click and the clickspring. (The plate P is shown in large size, while the click is still somewhat more enlarged.)

The recess *p* contains two step-like shoulders *p*<sup>1</sup> and *p*<sup>2</sup>; around the outer lower shoulder *p*<sup>2</sup> moves the click; the inner, higher shoulder or collet contains the screw-thread for the click screw and serves as rest for its head. Underneath the shoulder *p*<sup>2</sup> the recess is so deep that in it the clickspring C is placed so that it may function freely.

As will be seen from the sketch, the spring is a circular ring of a little less than a full circle, the ends of which are bent vertical to the plane of the ring—one end projects upward, the other downward. For the latter end there is a hole in the recess for the clickspring at *c*<sup>1</sup>, for the former in the disc of the clickspring at *c*<sup>2</sup> into which those ends of the spring C are pushed. The holes are located in such a way that when the

**The Latest Patents.**

ISSUE OF DEC. 11, 1894.

530,530. WATCH. JOHN L. HUTCHINSON, La-Porte, Ind.—Filed April 19, 1894. Serial No. 508,105. (No model.)

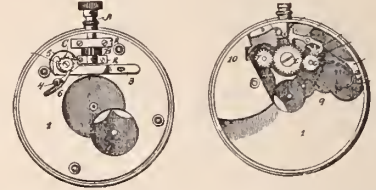

In a watch movement, the combination with the winding and the setting trains, and a pivoted yoke having mounted thereon a crown wheel, adapted to be revolved by the winding pinion, and in gear therewith, a setting wheel and an intermediate winding wheel adapted to be thrown into and out of gear with their respective trains by the pivotal movement of said yoke of means operated by the longitudinal movement of the watch stem in one direction, but independent of the movement of the same in the opposite direction, for effecting both the movement of the pivoted yoke.

DESIGN 23,557. WATCH-CHARM, & C. GEORGE



E. RHODES, Shreveport, La.—Filed Jan. 22, 1894. Serial No. 497,714. Term of patent 7 years.

DESIGN 23,558. BADGE. BENJAMIN S. WHITE HEAD, Newark, N. J.—Filed June 7, 1894. Serial

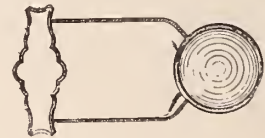

No. 513,831. Term of patent 7 years.

DESIGN 23,559. BADGE. BENJAMIN S. WHITE-HEAD, Newark, N. J.—Filed June 7, 1894. Serial No. 513,832. Term of patent 7 years.

DESIGN 23,560. PICKLE-FORK. LOUIS A. PLAGET, Paterson, N. J.—Filed Oct. 15, 1894.



Serial No. 525,992. Term of patent 3½ years.

DESIGN 23,561. KNIFE OR FORK HANDLE. HUBERT C. HART, Unionville, Conn.—Filed

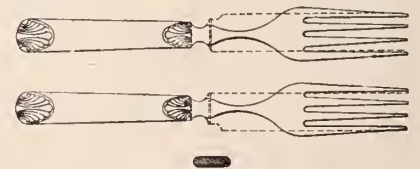

Aug. 22, 1894. Serial No. 521,036. Term of patent 7 years.

TRADEMARK 25,619. WHITE BRILLIANTS. RIPLEY HOWLAND MANUFACTURING COMPANY, Boston, Mass.—Filed Nov. 1, 1894.



Essential feature.—The representation of a shield surmounted by a crown and superposed upon a streamer or ribbon, and the words "SIBERIAN BRILLIANT." Used since October 24, 1894.





# RUDOLSTADT

## ART POTTERY.

CONTAINS all the elements required as to designs, decorations and workmanship, in a high grade of Art Goods adapted to the Jewelry Trade, and yields a larger margin of profit than any other class of Pottery.

**L. Straus & Sons,**

SOLE AGENTS,  
42-44-46-48 Warren Street,  
116 Chambers Street,  
NEW YORK.



**..THE LATEST..**  
**Sterling Silver Novelty,**  
**CIGAR CUTTER**  
**AND KEY RING COMBINED.**

Patented Nov. 20th, 1894.

WITH OR WITHOUT CHAIN.

MADE ONLY BY  
**ENOS RICHARDSON & CO.,**  
23 Maiden Lane, New York.

**SAFES FOR JEWELERS.**

**MOSLER, BAHMANN & CO.,** 518 BROADWAY  
NEW YORK.  
Patent Fire and Burglar Proof Safes.

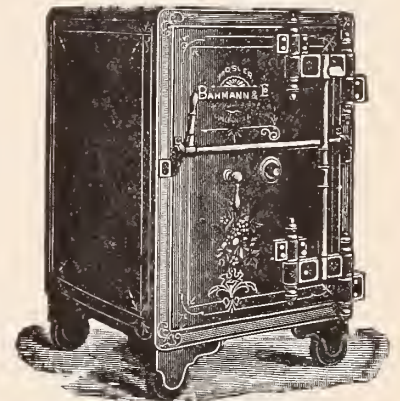

Large Assortment Always on Hand.  
Send for our Representative.  
Special Safes to Order.  
Jewelers' Safes a Specialty.

**THEODORE C. STEINHAUS,**

— MANUFACTURER OF —

### Fine Cases and Trays

For JEWELRY, SILVERWARE, &c.  
SAMPLE CASES AND TRAYS FOR TRAVELERS.  
Fancy Hard Wood Chests for Silverware, &c.  
Linings, Cushions, Mounting, etc., for Silver Novelties.

10 MAIDEN LANE. NEW YORK.

**H. M. RICH & CO.,**  
**Jewelry • Auctioneers,**  
21 School Street.  
BOSTON. MASS.



SPECIAL SALESMAN OF  
**WATCHES, DIAMONDS,**  
Bric-a-Brac  
and Art Goods  
FOR  
Established Jewelers.

WRITE FOR PARTICULARS.  
Communications Strictly Confidential.  
References given in all parts of the United States from Retailers and Jobbers.

**CODDING BROS. & HEILBORN,**  
North Attleboro, Mass.

Makers  
OF

## QUICK SELLING NOVELTIES

In Sterling Silver.

NEW YORK OFFICE—C. A. Vanderbilt, 178 Broadway.  
CHICAGO OFFICE—F. A. Buck, 103 State Street.



# FERDINAND BING & Co.,

106 GRAND ST., N. Y.



NEW DESIGNS IN \_\_\_\_\_

China Clocks and Gilt Bronze Sets, Fine Painted  
Dresden Goods in Vases, Cups and Saucers, and Plates;  
Cararra Marble Statuary, French Cabinets and other  
Fancy Furniture.

T O W L E MANUFACTURING COMPANY,

SILVERSMITHS,



NEWBURYPORT,

149-151 STATE STREET,  
CHICAGO, ILL.



**BURGLARY INSURANCE.**

**Fidelity AND Casualty Co.**

OF NEW YORK

**INSURES** Safes and their Contents

**Against Burglary.**

For Particulars, address the Company,  
40-146 BROADWAY, NEW YORK.

## BOYLE, DAVIS & GOODMAN,

SPECIAL AUCTIONEERS for the Legitimate Trade only.

83 Fifth Avenue  
NEW YORK.

611 Pennsylvania Ave.,  
WASHINGTON, D. C.



S. A. BOYLE.



W. M. DAVIS.



CHAS. P. GOODMAN.

**WE PAY ALL OUR OWN EXPENSES. GUARANTEE TO MAKE YOUR SALE WITHOUT LOSS.**

SEND FOR OUR BUSINESS PAMPHLET.

CONSULT US BEFORE PLACING YOUR SALE. ADDRESS ALL CORRESPONDENCE TO OUR WASHINGTON OFFICE.



### English Delft.\*

FROM Holland, where an ever increasing number of factories of the white ware coated with stanniferous enamel had already reached the highest degree of artistic and commercial development, the process was brought into England about the middle



SACK BOTTLE.

of the seventeenth century. It was the nearest approach to the Oriental porcelain, which was so much admired and so difficult to obtain. The Dutch, who imported those rarities from the West Indies, endeavored to transform into a plausible substitute the common white faïence they were then making, and by decorating in blue with subjects copied from the Chinese pieces, to realise, if not the unattainable transparence, at least all the outward looks of the Eastern china. They succeeded in producing such a close imitation that some of the blue and white Delft dishes might, at a distance, deceive the eye of even a connoisseur.

The body is of a yellowish or red color, very friable and porous; carbonate of lime enters largely into its composition. The glaze, a thick and opaque enamel, is a mixture of oxides of lead and tin. Its manufacture differed from all other early ware in this respect, that it had to be fired twice—once to harden the biscuit, so as to allow of its being dipped into the liquid glaze, the porosity of the body absorbing the water while the enamel remained on the surface,

\*Adapted from "The Art of the Old English Potter," by L. M. Solon. Copyright, D. Appleton & Co.

and then a second time to vitrify the glaze.

The earliest dated pieces considered to be English Delft, that is to say potted in England, were probably made with clay from Holland, as we may infer from the fact of their substance being very porous and easy to cut into with a knife, from its effervescing with nitric acid, and at a high temperature melting into a coarse glass. The native clays, however, were soon brought into use, and then we find the ware has been highly fired and can hardly be scratched with a sharp point.

However, the ware was made in England with the local materials, only the biscuit, being dense instead of spongy, does not, when dipped, retain a sufficiently thick coating of enamel, and its red color shows through, giving the ware that rosy tint so often observed by collectors; crazing is generally seen on the surface, through want of affinity between body and glaze. Dutch pieces, on the contrary, are as a rule free from this defect. The English potter was so well aware of this shortcoming that the early dishes were coated only on the front side, the back being glazed with the usual lead glaze and sometimes mottled with ordinary tortoise-shell colors. Whenever the



ENGLISH DELFT DISH. WILLIAM AND MARY.

style of painting, which otherwise is the safest guide for identification, appears doubtful, this should be sufficient to indicate the origin of a piece. Dutch dishes may be found similar in design, but they

are invariably enamelled on both sides; as to the few dishes of Italian make, which possess the same peculiarity of being glazed with lead on the back, their decoration is so characteristic that in their case a mistake is almost impossible.

England was not long in following upon the track of the Dutch potters who manu-



DELFT PUZZLE JUG.

factured in the town of Delft the first pieces of stanniferous faïence, decorated with blue and other colors. It is for us a fact worthy of remark that the oldest authenticated specimen of blue painted ware made at Delft is signed by an Englishman, one *Tome Jansz*, a Dutch mis-spelling, which conceals but imperfectly the British name of Tom Jones, a soldier, who is described as having been "born in England, beyond London," and who came to Holland with the English regiment commanded by Captain Hamwout (?) This interesting work is a dish painted with the Last Judgment—a subject comprising four hundred figures of the painter's own composition, and made by him in the factory of Herman Pietersz towards 1600.

Two very important documents referring to the making of Delft-ware in England are given by R. W. Binns in the appendix of his work—"A Century of Potting in the City of Worcester." (Second edition.) The first is a petition addressed to the king, Charles II., November, 1676, by several potters of the City of London, namely: John Ariens Van Haunne (the same again who appears in the specifications of patents at the date of October, 1676, as J. A. Van Hamme),

## The Connoisseur.

(Continued from page 39.)

James Barston, Daniel Parker, John Campion, Richard Newman and divers others, who complain that "notwithstanding the statute of Edward IV., prohibiting the bringing in of any painted wares into this kingdom by way of merchandise," etc., "several persons have presumed to import and daily to bring in several great quantities of painted earthenwares," etc., "to the inevitable ruin of the petitioners and many hundreds of poor men, women and children, whose subsistence and livelihood depend thereon, and the total destruction of the manufacture here, which is fully as well done as any foreign, and with most materials of English growth," etc.

To the Delft-ware succeeded the whole flint or Queen-ware in 1760, by Wedgwood. In 1716 the English Delft had already been brought near to perfection, as we can see by the large plaque preserved in the Mayer Museum; it is painted in blue, with a view of Great Crosby, the landscape being plentifully diversified with ships, houses, figures, and animals of all sorts. In the old church at Crosby may also be seen a plaque of the same ware, with the arms of the Merchant Taylors' Company, and the date, 1722. At that time the ware was already exported in large quantities, and numberless examples have been preserved to us dating far down in the eighteenth century. Among these may be mentioned tiles for fire-places, with blue landscapes and figure subjects; puzzle jugs of elegant shape, thinly potted and

brightly glazed, with dogrel verses painted all round; and especially large punch bowls, decorated with a ship in full sail and a border of Chinese flowers. On these the blue painting is so cleverly executed that they vie with many a piece made in Holland, and the artists had nothing more to learn from their masters. Shaw and Pennington were very celebrated for their punch bowls between 1750 and 1780.

At Vauxhall and Mortlake Delft-ware potteries were carried on, but no specimens have been so far identified as coming from these places. At Bristol English Delft was extensively manufactured from the beginning of the eighteenth century, but the potters of that city never attained to the degree of perfection which the art reached at Liverpool. Thomas Heath introduced Delft-ware into Staffordshire towards 1710.

We must say that the making of Delft-ware never interfered in England with the development of local productions, which continued to be made with native materials. Seldom do we find English Delft in pieces of general use in the country; for example, few, if any, tea-pots, mugs or common jugs are to be met with. It was limited rather to fancy articles, such as decorative tiles, vases and dessert plates.

Delft-ware became so fashionable that the English potters had to apply that name to such substitutes as they could contrive to manufacture. The ware has disappeared a long time ago, but the name has been preserved to this day, and all common crockery is still called Delft in many country places.

## The Rambler's Notes.

WHAT THE RAMBLER SAW AND HEARD AMONG THE DEALERS IN ART POTTERY, CUT GLASS, BRONZES, ETC.

RICH VIENNA  
NOVELTIES.

ONE of the most attractive lines of rich novelties ever shown by Bawo & Dotter, 30 Barclay St., New York, is now to be seen at their warerooms. The pieces are similar to Royal Vienna, being of the finest Dresden china, decorated by Knoeller, of Vienna. The subjects are reproductions of the finest paintings in the European art galleries, while the body color of the pieces is either a rich maroon or an apple green. This ware includes comb and brush trays, bonbon boxes and trays, tea caddies, chocolate cups, teapots, sugars, creams, pen and pin trays and odd shaped celery dishes. Altogether the pieces are considered by the importers to be the most perfect in detail and finish of any line they have ever carried.

C. L. DWENGER IN BUSINESS FOR HIMSELF. C. L. DWENGER, manager for the late A. Klingenberg, a well known importer of fine china, glassware and art pottery, will embark in business Jan. 1st. Mr. Dwenger, who is now in Europe purchasing goods, will, on his return, occupy the quarters formerly of Mr. Klingenberg, at 35 Park Place, New York, and will devote himself to importing French and Carlsbad china.

NEW SUBJECTS IN  
STATUARY

SOME new subjects in statuary were opened last week by L. Straus & Sons, 42-48 Warren St., New York. Among these late arrivals are three which may be classed with the finest pieces here shown. One is an idealized statue of Columbus, another the famous Venus de Canova, while the third, Wedding Jewels, represents a beautiful girl holding a basket of jewelry. All these figures are in Cararra marble and stand about four feet high.

A POPULAR LINE FOR  
PRESENTS.

ONE of the most successful lines suitable for presents is shown by Levy, Dreyfus & Co., 11 Maiden Lane, New York. It is their sets of cups and saucers arranged in satin lined cases. These sets comprise six or twelve cups and saucers, sometimes less, with a teapot, sugar and cream. They are shown in both French and Dresden china. The decorations are varied, including green and gold, floral, cobalt, blue and gilt, Watteau panels and other varieties. They will prove as popular for wedding as for holiday presents.

THE RAMBLER.



## HAGAN, WHITE & CO.,

MANUFACTURERS OF  
GOLD AND SILVER MOUNTED CANES, UMBRELLAS & NOVELTIES.

RICH AMERICAN CUT GLASS, SILVER MOUNTED.  
248 WEST 23D STREET. NEW YORK.

## Jules Jürgensen

OF COPENHAGEN.

The reputation these watches have maintained for Fifty Years has never been equalled, being made on strictly scientific principles and no expense spared to give the Best results in mechanism and timekeeping qualities.

SOLE AGENTS.

John C. Hyde's Sons,  
NO. 22 MAIDEN LANE.

## For BADGES and MEDALS,

Flag Pins, Class Pins, Class Rings  
and Special Work of all Descriptions,

SEND TO E. R. STOCKWELL, MANUF'R,  
19 John Street, New York.

**Diamonds Set in Teeth.**

**T**HERE is a comparatively new fad, which should it increase extensively may give a new field for the consumption of diamonds of the smaller sizes. This evolution of the essentially American demand for something new under the sun, consists of wearing a diamond inserted between or in the incisors of the lower or upper jaw. The innovation is due to Dr. Luella Cool, a dentist of San Francisco, who has by reason of this and other radical departures from the strict lines of her profession, become known throughout the country.

Dr. Cool, who recently arrived in New York, visited THE CIRCULAR office and explained her processes. She is a handsome brunette, and when she smiles shows two diamonds set in her front teeth—one in the upper and the other in the lower jaw—which give a dazzling effect. The diamonds, she explains, are set in the teeth by one of two methods: the first is similar to that used by a jeweler in setting a ring, the setting being filled in and burnished down; the other method is to cement in the stone. The acid or saliva has no effect on the gem, nor is the stone noticeable when coming in contact with the lips.

The cost of the diamond work varies and depends on the size and purity of the gem. Dr. Cool does not confine herself entirely to diamond work, but is proficient in all branches of dentistry, she having also originated the idea of gold crown work, with the name and city of residence engraved thereon as means of identification in case of accident or sudden death. In her own mouth Dr. Cool has a gold crown, inserted by herself, on which is engraved "L. Cool, 1893"—the latter being the year she originated the idea.

Dr. Cool claims to have set many diamonds in the teeth of ladies of San Francisco and other western cities, and expects that the fad will spread. She starts the latter part of this month for Guatemala, where she

will practice her profession. The Central Americans, as a people, are passionately fond of diamonds, and wear them on all occasions, and therefore the charming doc-



DR. LUELLA COOL.

tor expects to have a large demand for her work.

**North Carolina Emerald Mine.**

**G**EORGE F. KUNZ, in the *American Journal of Science*, says: In July, 1894, a new locality of true emeralds was discovered by Mr. J. L. Rorison, miner of mica, and Mr. D. A. Bowman, on the Rori-

son property, near Bakersville, Mitchell county, N. C. Here, at an elevation of 5,000 feet a. t., on Big Crab Tree mountain, occurs a vein of pegmatite some five feet wide, with well-defined walls, in mica schist. This vein carries a variety of minerals besides its component quartz and feldspar, among these being garnets; translucent, reddish and black tourmalines, the latter abundant in slender crystals; white, yellow and pale green beryls and the emeralds.

These latter are chiefly small, 1 to 10 mm. wide by 5 to 24 mm. long, but some have been found two or three times larger than the larger size named. They are perfect hexagonal prisms, generally well terminated, and are clear and of good color, with some promise for gems. They very strikingly resemble the Norwegian emeralds from Arendal. One vein outcrops for perhaps 100 yards, with a north to south strike.

The results thus far obtained are only from about five feet depth of working, so that much more may be looked for as the vein is developed. The locality is 14 miles south of Bakersville, and about the same distance from Mitchell's Peak, a little north of the crest of the Blue Ridge. It is some 50 miles west of the emerald locality at Stony Point, Alexander county, N. C., described by William Hidden in 1851, in a pamphlet privately printed at New York.

Portraits of the late czar, with frames in silver and gold filigree adorned with *cabochons*, are exhibited in several Paris jewelry stores. A remarkable one has a very close network made of fine platina wires deeply oxidized, imitating crape, draped over one of the top angles of the frame. A branch of cypress formed of emeralds and a spray of everlasting flowers made of a gathering of topazes are tied together with a ribbon of snow-white silver and thrown across the crape-like platina network.

**THE AMERICAN KNIFE AND SCISSORS SHARPENER.**

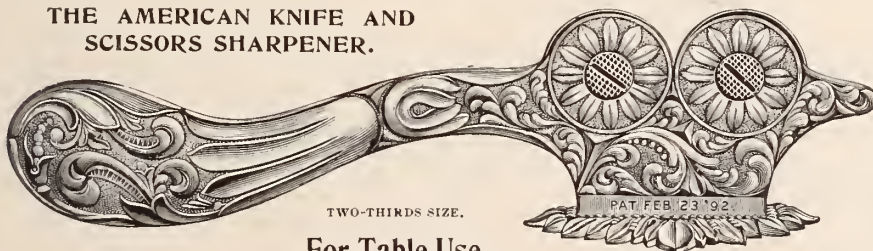

TWO-THIRDS SIZE.

For Table Use.

Special Inducements to Jobbers

... Manufactured only by the

**MOSSBERG WRENCH CO.,**  
ATTLEBORO, MASS.

Makers of **Novelties in Silver and Hardware.**

- FOR SALE BY**  
Benj. Allen & Co., Chicago, Ill.  
F. M. Sproehle & Co., "  
G. A. Webster, "  
L. Straus & Sons, New York.  
E. G. Webster & Son, "  
Oskamp, Nolting & Co., Cincinnati, O.  
Baldwin, Miller & Co., Indianapolis, Ind.  
Eliassof Bros. & Co., Albany, N. Y.  
Thos. Long & Co., Boston, Mass.  
Smith & Patterson, "  
Dame, Stoddard & Kendall, Boston, Mass.

**Practical and Handsome.**

A Silver Plated Knife and Scissors Sharpener, retailing at a popular price. Perfect in action, nothing to wear out. Cutting discs of finest hardened steel. An ordinary sharpness or a RAZOR EDGE can be acquired in a few moments.

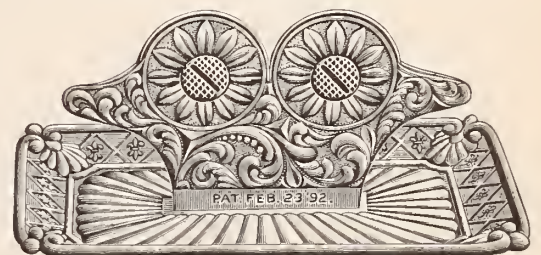

TWO-THIRDS SIZE.

FOR DESK USE.



# Perfect Construction

AND

## SUPERIOR FINISH

MAKE OUR PRODUCTIONS OF

### HIGHEST GRADE.

JEWELERS and  
FANCY GOODS DEALERS

will find in our new line of

## Art Metal Goods

many articles specially adapted  
to their trade.



### The Finest Line of Banquet Lamps

EVER PRODUCED.

Fitted with the Celebrated "B. & H." Burner.

New and Attractive Designs and Finishes. Sure to be Ready Sellers.

We will send you our Little Book, giving more information, if you desire, and will be glad to have you visit our Salesrooms and see the Goods.

## BRADLEY & HUBBARD MFG. CO.,

NEW YORK, PHILADELPHIA, BOSTON, CHICAGO,

28 PARK PLACE 710 BETZ BLD'G. 160 CONGRESS ST. 204 MASONIC TEMPLE  
TO 21 BARCLAY ST. FACTORIES AND OFFICES, MERIDEN, CONN.

## Now that we have touched bottom

And business generally is improving every GOOD RETAIL JEWELER should make his stock attractive and so invite customers. He can buy nothing more sure of sale than



1007



of standard quality, at moderate cost, and of new and taking styles. If not called upon by our travelers send your orders direct to

### M. B. BRYANT & CO.,

10 MAIDEN LANE, NEW YORK.

IMPORTERS OF  
**DIAMONDS.**

JOBBERS IN  
Watches, Jewelry, Chains,  
NOVELTIES, ETC.  
Latest Designs. Lowest Prices.

### The Other Side of Life.

#### HOLIDAY ATTENTIONS.

"MY dear, you're looking very tired to-night,"  
(That means a Christmas cloak.)  
"I'll get your slippers and your pipe—a light."

(That's business, and no joke!)

"You'll kill yourself if you keep working so!"  
(That speech is bound to win!)

"Darling, I could not live if you should go!"  
(That means a diamond pin.)

"I've had the girl make just the nicest tea!"  
(My head has fallen back.)

"The kind you liked best when you married me!"  
(Mercy! a fur-trimmed sacque!)

"Poor, tired dear! I'll rub your head for you!"  
(In mute despair I look.)

"When I go shopping I'll be tired, too!"  
(That means—my pocketbook!)

—A Georgia Exchange.

Consistency is a jewel which many of us are saving for a crown setting.

Smith, Gray & Co.'s Monthly.

HE—Your heart is of so hard a substance, I find nothing will penetrate it.

SHE (cooly).—Why not try diamonds?

Smith, Gray & Co.'s Monthly.

No wonder a woman thinks herself good enough to eat when her complexion is flour and her diamonds paste.—Boston Transcript.

#### LOVE BRAVES ALL DANGERS.

EDITH—Surely Mabel isn't going to cross the avenue in this storm.

MAUD—Yes, she is; I know that Jack Dasher proposed to her yesterday, and she'd show that engagement ring to me if she had to swim over.—Judge.

#### USEFUL INFORMATION.

FIRST UNDERGRADUATE—What made you rush out as soon as you opened that package from home and got the gold watch your pater sent you for a Christmas present?

SECOND UNDERGRADUATE—I wanted to see how much I could get on it.—Puck.

It was evident that they were man and wife and were returning from assisting at the wedding of two of their friends. "Wouldn't it be awful," she was heard to say to him, "if they were to live together long enough to find out that the silver we gave them was only plated.—Indianapolis Journal.

IMPORTERS OF

JOBBERS IN

**AIKIN-LAMBERT  
JEWELRY CO.,**

19 Maiden Lane, New York.

CHICAGO BRANCH: 103 STATE ST.

# The Best Chatelaine is the Lady Racine.

## STEEL CASES & SILVER CASES.



10 LINE.

- Made in 10 Line Open Face.
- “ 11½ Line Open Face and Hunting
- “ 13 Line Open Face and Hunting.

THE SILVER CASES ARE 0.935 FINE.  
THE MOVEMENTS HAVE 10 JEWELS  
THE ENGRAVINGS ARE CHOICE.



13 LINE

## MADE IN 12 LINE OPEN FACE.

In Silver Cases only.

Case 0.800 Fine with a 6 Jewel Movement.  
Expressly Gotten Up to Suit the Times.



12 LINE

A GOOD Chatelaine Watch at a LOW PRICE.

Do not fail to ASK YOUR JOBBER FOR THE NEW  
12 LINE LADY RACINE in 0.800 Cases.

# CARBORUNDUM.

## Net Retail Price List of Carborundum Wheels.

ACEESON'S PATENT, February 28th, 1893.

Diam. in Inches	THICKNESS IN INCHES.																Rev. per Minute.	
	¼	⅜	½	⅝	¾	⅞	1	1¼	1½	1¾	2	2¼	2½	2¾	3	3½		4
1	\$.15	\$.18	\$.20	\$.23	\$.25	\$.28	\$.30	\$.35	\$.40	\$.45	\$.50	\$.55	\$.60	\$.65	\$.70	\$.80	\$.90	18,000
1½	.18	.22	.25	.28	.31	.33	.35	.40	.45	.50	.56	.62	.67	.73	.78	.90	1.00	14,000
2	.20	.25	.30	.34	.37	.40	.42	.46	.52	.58	.65	.70	.77	.85	.90	1.00	1.20	11,000
2½	.25	.30	.37	.42	.46	.48	.50	.55	.60	.67	.75	.80	.91	.98	1.05	1.20	1.40	8,800
3	.30	.38	.45	.50	.55	.58	.60	.65	.70	.78	.85	.95	1.05	1.15	1.25	1.45	1.65	7,400
4	.65	.70	.75	.80	.85	.90	.95	1.10	1.30	1.50	1.65	1.80	2.00	2.15	2.35	2.70	3.05	5,500
5	.85	.90	.95	1.05	1.15	1.25	1.35	1.65	1.90	2.20	2.45	2.75	3.05	3.30	3.55	4.15	4.65	4,400
6	1.10	1.20	1.25	1.45	1.60	1.80	1.95	2.35	2.75	3.15	3.55	3.95	4.33	4.75	5.15	5.95	6.75	3,700
7	1.35	1.55	1.70	1.90	2.10	2.35	2.60	3.15	3.70	4.25	4.80	5.35	5.75	6.45	7.00	8.10	9.20	3,160
8	1.65	1.90	2.15	2.45	2.75	3.05	3.35	4.05	4.80	5.50	6.25	6.95	7.65	8.35	9.10	10.50	12.00	2,750
9	2.00	2.40	2.65	3.10	3.40	3.80	4.15	5.10	5.45	6.90	7.80	8.75	9.65	10.55	11.45	13.25	15.10	2,450
10	2.45	2.80	3.25	3.70	4.15	4.65	5.10	6.25	7.40	8.50	9.60	10.70	11.85	12.90	14.05	16.30	18.55	2,200
12	3.60	4.00	4.40	5.10	5.80	6.50	7.20	8.80	10.40	12.00	14.60	15.20	16.80	18.4	20.00	24.55	26.40	1,830

CARBORUNDUM was awarded both a Medal and a Diploma at the World's Columbian Exposition in recognition of its merits as an Abrasive, the hardness being greater than any other abrasive material.

The wheels are made with a vitrified bond, and pressed under hydraulic pressure. Those over three inches in diameter are turned up after firing. The same numbers are used to designate the degrees of fineness, as are used with Emery, and the wheels are made in seven degrees of hardness, marked SSS, SS, S, M, H, HH, HHH, from extremely soft to extremely hard.

In ordering, state diameter, thickness, hole, number and hardness.

Monongahela, Pa., U. S. A.

THE CARBORUNDUM COMPANY.

Hones, Slabs, Files.

Cut = This = Out.

# AIKIN, LAMBERT & CO.,

CHICAGO BRANCH: 103 State Street.

No. 19 MAIDEN LANE, NEW YORK.

Manufacturers and Exporters  
Gold Pens, Holders, Pencils,



Toothpicks and Novelties

MERCANTILE

FOUNTAIN PEN.

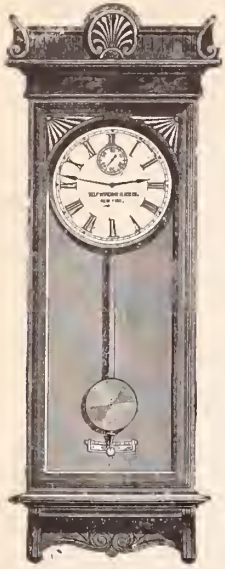

**SELF WINDING CLOCK CO.**

NEW YORK-CHICAGO.

**HALL CLOCKS,  
OFFICE CLOCKS,  
Synchronized Time Plants.**

No Winding. Corrected Hourly

BY TELEGRAPH SIGNALS OVER WESTERN UNION TEL. CO.

Wires from U. S. Naval Observatory, Washington, D. C.

General Office:  
26 BROADWAY, N. Y.

Branch Office:  
Columbus Memorial Bldg, Chicago.

Sold by all whole-  
sale dealers at manu-  
facturer's price.

**A. N. CLARK & SON**  
PLAINVILLE  
CONN.

Manufacturer of the Celebrated  
**LOOP WATCH KEY.**

The Best for the Price in the World.  
CROSBY'S JEWELING TOOLS IMPROVED.

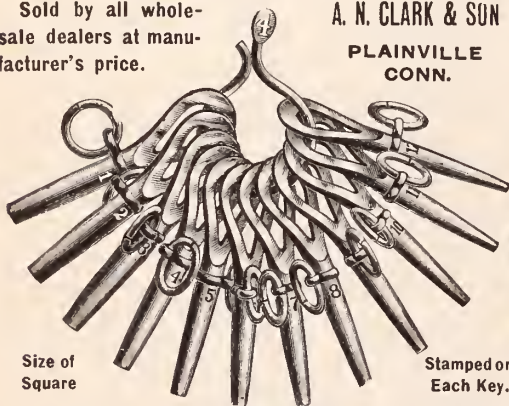

Size of  
Square

Stamped on  
Each Key.



Will quote royalty or price for the manufacturing of articles of real worth.

**B. & W. B. SMITH,**  
220 W. 29th St., New York.

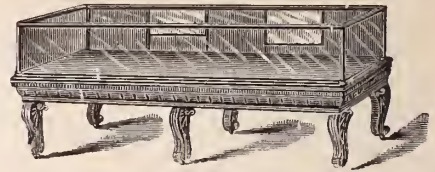

Improved Dust-Tight Counter Cases,  
Perpendicular Sliding Doors.

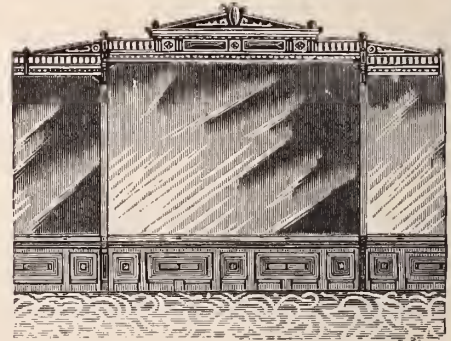

Improved Dust-Tight Wall Cases.  
Furnished with Improved Shelving and ar-  
ranged for Electric Lighting.



.. OUR ..  
**SPECIALTY**

The Largest Stock of  
**CHIMING  
AND  
STRIKING  
HALL CLOCKS**

ever shown.

**Chas. Jacques**

**CLOCK CO.,**  
22 Cortlandt Street,  
NEW YORK.

**DIAMONDS.**

**C. COTTIER & SON,** IMPORTERS OF  
PRECIOUS STONES,  
14 MAIDEN LANE, NEW YORK.  
C. A. RICHARDS, Agt. 151 Weybosset St., Prov., R. I.

**FANCY GEMS.**

**\$3.00 FORMERLY \$6.00**

Ivory and  
Enamel  
Miniatures

Best  
Workmanship.



Original  
Inventor and  
Patentee of  
**Miniatures**  
—ON—  
**Gold and  
Silver.**

PATENTED  
November 12, 1889

**LEON FAVRE,** 107 EAST 26TH STREET,  
NEW YORK.

**U. S. SMELTING & REFINING WORKS,**

Sweep Smelting and Assaying, Platinum in Plate and  
Wire. Chemically Pure Copper, Ore and Bullion  
Assays a specialty.  
Highest prices paid for old gold and silver.  
Sole manufacturers of Phoenix Flux  
and Eureka Alloy.

**M. WOLLSTEIN,** 25 John St., New York.



**S. F. MYERS & CO.,**

Manufacturing and  
**WHOLESALE JEWELERS,**  
1895 Issue, No. 39.

**OUR ROYAL CATALOGUE**

Illustrates all that is new, unique  
and desirable in

everything that pertains to jewelry.  
600 pages, size of this publication.  
Free to dealers.

**SEVEN DOUBLE FLOORS.  
TWENTY-TWO DEPARTMENTS.**

Myers Buildings, 48-50 Maiden Lane,  
33-35 Liberty St., New York.

**DIAMONDS** and Cutters. **L. & M. KAHN & CO.,** 172 Broadway, New York.

**IT PAYS** TO KEEP IN TOUCH WITH TRADE AFFAIRS. **THE JEWELERS' CIRCULAR.** For 4c. a Week will do it. **Subscribe.**



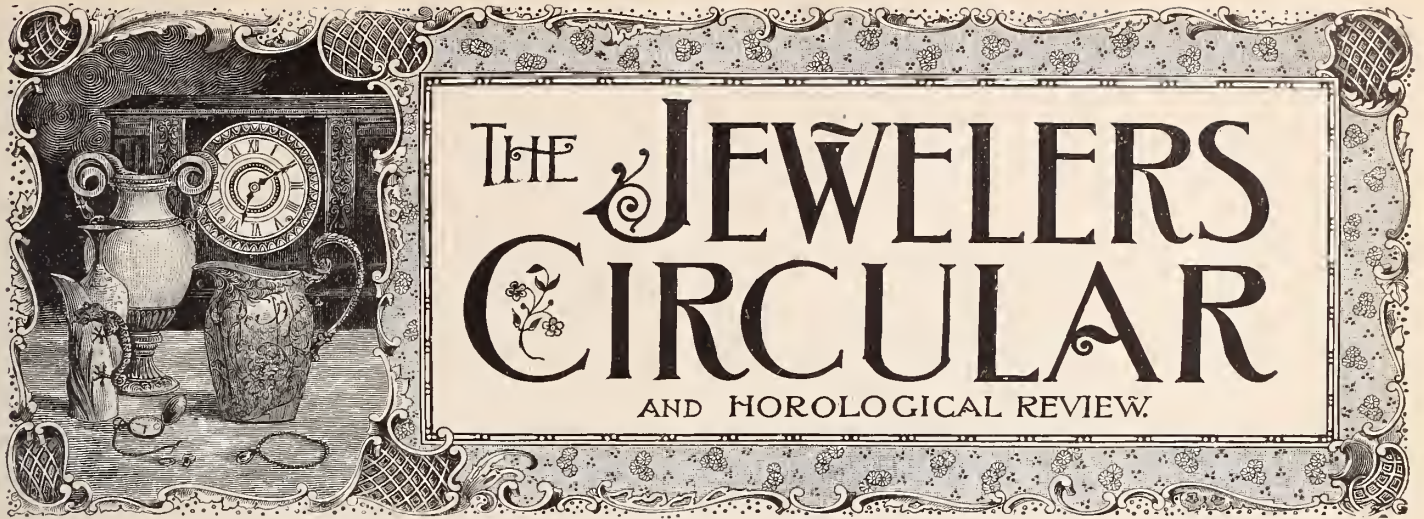

Copyright by THE JEWELERS' CIRCULAR PUB. CO.

189 Broadway, New York.

Entered at the Post Office in N. Y. as second-class matter.

VOL. XXIX.

NEW YORK, WEDNESDAY, DEC. 26, 1894.

NO. 22.

THE FLOWER IN JEWELRY AND SILVERWARE.

PART II.

PARIS, France, Dec. 5.—Some silversmiths obtain very remarkable effects with exact copies of flowers, plants and vege-

or the like. A sugar basin has the shape of a nenuphar; a butter dish resembles an artichoke. Trays consist of vine leaves, faithfully reproduced by an electrotypic process. Tea sets, candlesticks, jardinières, cups, goblets, plates, etc., are covered with garden or hot house flowers and plants in low or high relief, oxidized or in gilt of various tints, some articles showing Oriental flowers in *cloisonné*.

tankard. The wide-awake mouse resting on the top stalk serves as a knob to lift up the lid. Another little mouse in the lower part of the vessel, at the left, is tasting hops, while, near the base, a lizzard full of life, is catching a fly.

Fig. 6 shows a marvellous piece of workmanship in silver, made at Falize's. The metal looks soft and pliable like the sub-



FIG. 4. AGRICULTURAL CUP, BY CHRISTOFLE.

An agricultural prize cup, Fig. 4, in silver, is adorned with wheat and flowers of the field apparently growing up its body. A Ceres head in high relief with flowers and leaves among the hair and around the neck, and resting on a console, divides into two halves, one side of the cup.

tables selected, grouped and arranged so as to give an harmonious ensemble. They reproduce these works of nature either to vary the outlines of their wares or to decorate them. In Christofle & Co.'s exhibit at the Exposition de Fleur, there are three original silver vases. One consists of four leek roots forming the feet of the vase with their leaves tied together. Another shows three carrots, the leaves of which prettily intertwined and tied with roots, rise up gracefully, the top leaves falling back so as to give a curved rim to the opening of the vase. Another is an onion standing on its round part.

Several *drageoirs* (bonbon servers) have the appearance of half a lemon, peach, pear

All works made by the brothers Fanniére, of whatever size or use, are always finished to perfection. These impeccable artists display as much talent in the chasing of a mug, as they do in the modeling and the embossing of a shield. Fig. 5 reproduces an ale tankard in silver at once remarkable for its fitness and for the taste exhibited in its decoration. The handle is formed of hop stalks, twisted in a natural manner, so that one stalk spreads over the lid and the others shoot sprigs of hops sparingly over the wall-like body of the

stance of the vegetables it reproduces. The three tulips half open forming the sockets of a candelabrum, and the three onion



FIG. 5. ALE TANKARD BY FANNIERE.



THE LATEST NOVELTY  
IN  
BIBLE BOOK-MARKS.

MOUNTED WITH  
Sterling Silver or Gold Ornaments,  
ON ALL SILK RIBBONS, 8 1-2 INCHES LONG  
WITH APPROPRIATE QUOTATIONS  
**WOVEN IN THE SILK.**

Nine different quotations. Ribbons in the following colors: Purple, black, white and lilac. Can be sold profitably at a popular price. Made only by

**STONE BROTHERS,**  
535 Broadway, NEW YORK.



355 Mulberry Street.

Newark, N. J.



KETCHUM & McDOUCALL,  
MANUFACTURERS  
GOLD & SILVER THIMBLES,  
GOLD COLLAR BUTTONS,  
AUTOMATIC EYE-GLASS HOLDERS  
198 BROADWAY N. Y.



ILLUSTRATED CATALOGUE SENT ON APPLICATION

**HAGAN, WHITE & CO.,**  
MANUFACTURERS OF  
GOLD AND SILVER MOUNTED CANES, UMBRELLAS & NOVELTIES.  
RICH AMERICAN CUT GLASS, SILVER MOUNTED.  
248 WEST 23D STREET, NEW YORK.

ONE TRIAL

OF OUR WORK ON REFINING FOR  
ALL KINDS WILL CONVINCING YOU  
THAT OUR RETURNS ARE THE BEST



CONVINCE YOURSELF.  
**GEO. M. BAKER,**  
Gold & Silver Refiner  
and Sweep Smelter.  
PROVIDENCE, R. I.

When you buy  
Cut Glass  
You want the best!  
That which bears our Trade Mark  
Has no superior  
And will prove profitable and satisfactory.

**T. B. CLARK & CO., Inc.,**  
860 Broadway, N. Y.,

Factories, HONESDALE, PA. N. E. Cor. 17th St. & Broadway.



SPECIALTY: SALES OF  
**JEWELRY BRIC-À-BRAC**  
AND  
ARTICLES OF VERTU



# Foster & Bailey,

MANUFACTURING JEWELERS AND SILVERSMITHS,

100 Richmond St., Providence, R. I.



**S**TERLING SILVER  
MANICURE SETS,

925-1000 Fine,

With Shoe Horn and  
Shoe Buttoner.

MADE OF THE BEST STEEL PARTS.

Put up in Fine Leather Roll,  
Lined with Dark Green Velvet  
and Having Beautiful Silk Flaps  
to fold over.

When Rolled Up it is Soft,  
Pliable, and Just the Thing to  
Pack in a Grip.

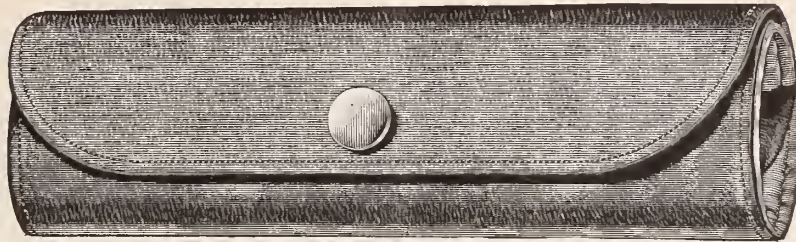

SET ROLLED UP—REDUCED ONE HALF EACH WAY.

Manicure Goods, Emery  
Strawberries, Pen Wipers,  
Garters, Paper Cutters, Pock-  
et Combs, Match Boxes,  
Knives, Embroidery Scis-  
sors, Collarettes, Seals, Key  
Rings and Chains, Shoe But-  
toners and Glove Buttoners,  
and lots of other nice things,

Rolled Plate Watch Chains,  
1-10 Gold Vest and Dickens  
Chain, Chain Mountings,  
"Mount Hope" Buttons, Link  
Buttons, Locketts and  
Charms, Solid Gold Locketts,  
Bracelets, Neck Chains, Pins,  
Crosses, Earrings.



NO. 7 SET—REDUCED ONE HALF EACH WAY.

No. 138 File and Cuticle Knife Combined.  
" 139 Corn Knife.

No. 140 Button Hook.  
" 141 Shoe Horn.

No. 142 Nail Cleaner and Ear Spoon.  
" 143 Curved Scissors.

MANICURE SETS IN FINE KID CASES.

## STERLING SILVER SET No. 1, CONTAINS :

No. 54 = Tray.	No. 57 = Paste Box.	No. 59 = Corn Knife.	No. 70 = Long Scissors.
" 55 = Polisher Box.	" 57 = Powder Box.	" 60 = Cuticle Knife.	Box.
56 = Polisher.	" 58 = File.	" 61 = Short Scissors	

No. 2 and No. 3 also in Sterling Silver, with less pieces, therefore cheaper in price. Nos. 4, 5 and 6 are in 1-10 Gold. All parts can be ordered separately, and all steel is of the best.

stalks, with their roots overlapping each other, arranged so as to form a *porte bouquet*, are perfectly modeled and chased. The leaves and stems curl and bend gracefully as in nature, and although these vegetables seem to grow freely, the ensemble is



FIG. 8. CLOISSONNÉ DISH, BY BARBEDIENNE.

at once very artistic and well calculated for use.

Fig. 7 shows a pretty jardiniere sparingly decorated with hawthorne buds and flowers in low relief. This jardiniere, in polychrome finish, rests on four pinecones, slanting prettily; other cones placed on the sides serve as handles.

Let us also mention a dish (Fig. 8) from Barbedienne's. It is magnificently decorated in cloisonné. The nenuphars, reeds and other aquatic plants are most faithfully rendered, and the wild duck soaring over the water is as real as possible. The border of the dish, covered with a fine and *fouillé* course of conventional foliage, is skilfully opposed, as a suitable frame, to the picture so clear, so open and so refreshing.

### A Notable Ecclesiastical Set.

THE communion service presented to Father Brown by the parishioners of the Church of St. Mary the Virgin, New York, in connection with the laying of the corner stone of the church, Dec. 8, purchased of Tiffany & Co., consists of seven pieces—a chalice, a flagon, two crewetts, tray, paten and lavabo. The crewetts are of fine crystal with silver-gilt mountings set with semi-precious stones. The other pieces are of solid silver, richly gilt, with semi-precious stones embedded in the mountings. The stones introduced are used in the same way as by the early ecclesiastics for the ornamentation of their church vessels.

The chalice, the principal piece of this remarkably beautiful service, is an example of the possibilities of ecclesiastical enamel and decorative work. The decorations are

Florentine, in repoussé and applied work. Around the bowl of the chalice are enameled medallions representing "The Last Supper," "The Entombment," and "The Resurrection." Upon the four knopes on the center of the stem are enameled miniatures of the four evangelical attributes—

Matthew . . . the man  
Mark . . . . the lion  
Luke . . . . the ox  
John . . . . the eagle.

The foot of the chalice is in quatrefoil shape, with enameled representations of the following Biblical scenes in the four compartments or panels :

"Moses striking the rock from which gushed forth water."  
"Israelites who had been bitten by the fiery serpent directed to look to the brazen serpent for healing."  
"The two spies, bearing on a pole between them the grapes of Eschol."  
"The Institution of the Feast of the Passover, represented by the slaying of the lamb and the sprinkling of the blood on the lintel."

Dividing the compartments are four dragons or spirits of evil; these spring from the stem and stand aloof, having "no part nor lot" in the holy scenes depicted. The chalice stands 10 inches high, and in addition to the other decorations is studded with en cabochon cut carbuncles, symbolic of wine. Under its base or foot is engraved the following inscription:

Presented to the  
Reverend Thomas McKee Brown, Priest,  
on the  
Feast of the Conception  
of the  
Blessed Virgin Mary, 1894, A. D.  
by the loving parishioners  
in commemoration  
of the



FIG. 7. JARDINIÈRE, BY FALIZE.

25th Anniversary of the organization  
of the  
Parish of St. Mary the Virgin,  
New York.

The paten is of silver and richly gilt. On the under side is a panel enameled in red and blue of the Paschal Lamb, with nimbus around its head, and to the right the flag and the Latin cross. From the Lamb's side flows its lifeblood into a chalice. Forming a border about the picture are the words "Panis Vivus" and "Agnus Dei."

There is a handsome oval tray for the two crystal crewetts, of solid silver, richly chased and gilt all over, and studded with chrysoptases. In the quatrefoil corners are four medallions in blue enamel representing

the four prophets, Isaiah, Jeremiah, Ezekiel and Daniel, with the name of each inscribed above in Latin. The crewetts have dragons for handles, signifying that all evil is on the outside. The base is hexagonal in shape and set with aquamarines. Upon



FIG. 6. SILVER CANDELABRA, BY FALIZE.

the cover of one, around the dome, are the letters A Q U A., followed by the chrisma, with an aquamarine set in the knob. In the knob of the other crewett is a garnet, symbolizing wine, and around the cover are the letters V I N U M.

In addition to these pieces, there are flagon and a lavabo (the ecclesiastical bowls), both of solid silver and gilt, to match the other pieces, but not enameled or studded with stones. The set is fitted into a handsome black seal leather case.

### The Age of the Chafing Dish.

WOMEN who first prized their chafing dishes for their convenience are now feeling an added pleasure in using a utensil that has a history at least of 2,000 years, says an exchange. They refer to what Seneca said of them, and quote Soyer's description of those used by the ancient Greeks and Romans. The dish is also referred to by Cicero and is supposed to be the "authepsa," a kind of saucepan of Corinthian brass of considerable value and made with such art that its contents cooked instantly and with little fire.

This simple and ingenious vessel possessed a double bottom, the uppermost one holding the light delicacies destined for desert, and the fire was underneath. The chafing dish was known in America as early as 1720.

George R. Bergen has opened a new jewelry store in Carson City, Mich.

*Pairpoint*

# MANUFACTURING COMPANY.

## Gold and Silver Plate



No. 3749 MATCH HOLDER.

WE ARE MAKERS OF THE  
LARGEST AND LOWEST PRICED

.....LINE OF.....

“Crown Pairpoint” China  
Rich Cut Glass,  
Fine Decorated Art Goods,  
.....TO BE FOUND IN THIS COUNTRY.



No. 4908. SMOKING SET.

“WHEN IN DOUBT”

--- BUY ---

✻ PAIRPOINT GOODS.

Factories, New Bedford, Mass.

### HOLIDAY NOVELTIES

..... OF EVERY DESCRIPTION.

**FREE**

OUR LATEST

SILVERWARE CATALOGUE No. 10, or  
CUT GLASS CATALOGUE No. 11

Will be mailed you upon receipt of address



SALESROOMS:

- NEW YORK, 46 Murray Street.
- CHICAGO, 224 Wabash Avenue.
- SAN FRANCISCO, 220 Sutter Street.
- MONTREAL, P. Q., Temple Building.

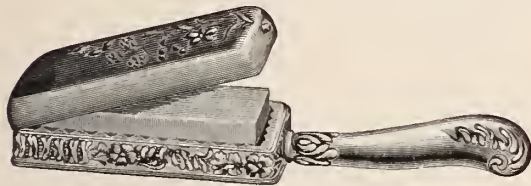

No. 2832. KNIFE SHARPENER.

We sell to the legitimate Jewelry and Stationery trade only.



### CHOICE PAPERS

MAKERS OF

## FINE STATIONERY

For Correspondence, Wedding and Business Use, handsomely boxed, specially suited to the Jewelry Trade.

18 MURRAY STREET, NEW YORK.

### LATEST STYLES

... IN ...

## FINE JEWELRY.

- GOLD BUCKLES,
- HAIR PINS,
- BACK COMBS,
- SIDE COMBS,
- NECK ORNAMENTS, Etc.

John A. Riley & Sloan Co.,  
Broadway and 17th Street,  
NEW YORK.

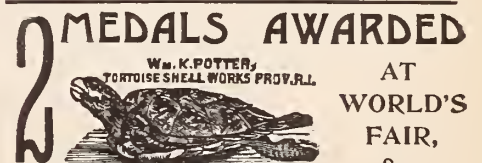

Providence Shell Works, Providence, R. I.  
Correspondence Invited.

# R. WALLACE & SONS MFG. CO.

## SILVERSMITHS,

WALLINGFORD, - - - - - CONN.



No. 20. FLASK.

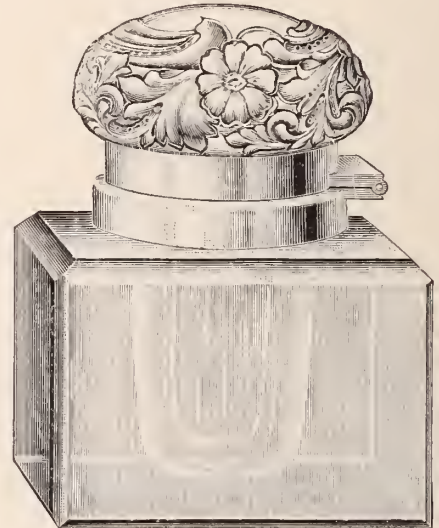

No. 53. INK BOTTLE.  
CHASED TOP.

Trade Mark.

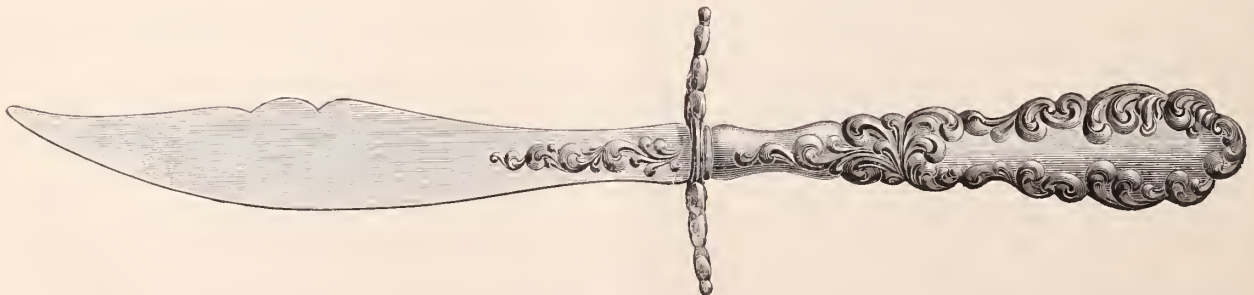

No. 39. PAPER CUTTER.

NEW YORK  
226 FIFTH AVENUE.

SAN FRANCISCO  
120 SUTTER STREET.

CHICAGO  
86 WABASH AVENUE.

**Fashions in Holiday Jewelry and Silver Novelties.**

A LADY'S RAMBLES AMONG THE JEWELERS.

The mounting of testimonials has become an important consideration.

The enamel and gem besprinkled sleeve holders are one of the luxuries of a working man.

Individual dishes have been provided for serving terrapin. They are silver and silver plated.

Beveled glass plateaux for the dinner table are among the things the jeweler is expected to supply.

Buckwheat cake covers are timely reminders of the season, and a welcome addition to the mistress' plate.

There are fifteen different articles essential to a well equipped five o'clock tea table that the jeweler can provide. One that he may neglect is tea glasses mounted in silver for Russian tea.

Fourteen pieces are comprised in a well furnished manicure case. These are nail brush with cover, brush stand and trays, nail cleaners, nail clippers, nail files, nail polishers, powder boxes, powder brushes, scissors, scrapers. Ivory, pearl, shell and silver are the mountings.

Ale mugs are made a speciality of during the holidays. The popular sort is not the

long, but the short, squatty mug. It is of gray stoneware with a suitable design in color. These designs are frequently copies of well known pictures. The covers are metal or silver plated. Collections of beer mugs, tobys, tankards and growlers are in order and illustrate the breadth and tolerance of the collecting mind.

A curious demand has sprung up for antique coins. No one in whose breast this desire has come is content with copies. The thing is the real coin. This is set in a hollow rim of gold or silver and mounted as clasps, charms, pendants or sleeve buttons. The dealers in these give lists of the coins. Some are more valuable than others. The most beautiful are the silver Greek coins coined 600 B. C. The drachmas and didrachmas are used for scarf pins and charms. The obolus is used for sleeve buttons. The Greek gold coins descend from the days of Philip of Macedon and Alexander the Great. The gold obolus is so tiny that it answers for a stud. Modern coins in demand are the square guineas of George III, the twenty franc pieces of Napoleon I, and still rare the twenty franc pieces of the second French Republic.

ELSIE BEE.

In a circular letter received from Goschler & Co., Bienne, Switzerland, this old house announce that they have received a silver medal at the Universal Exposition of Lyons, for the perfection of their products.

ESTABLISHED 1870.



TRADE MARK.

**SAMUEL C. JACKSON,**

MANUFACTURER OF

**FINE CASES FOR**

Jewelry, Silverware, &c., also Hardwood Chests, Trays, and Sample Cases.

**180 BROADWAY,**

**NEW YORK.**

**WOOD & HUGHES,**  
**STERLING SILVERWARE MANUFACTURERS**

New York Agents for the Derby Silver Co.

**FINE QUADRUPLE PLATED WARE,**  
No. 16 JOHN STREET, NEW YORK.

206 Kearney St., San Francisco, Cal.

**HASKELL & MUEGGE, Agents.**

**Philadelphia College of Horology**

Is not the largest but is the finest school in the country. A practical school to learn watch-making, engraving, and jewelry repairing. One tuition pays for all branches. Send for prospectus.

**F. W. SCHULER, PRINCIPAL,**  
1213 Filbert St., Philadelphia, Pa.

Write for particulars of our corresponding course.

**THE SOUL OF THE DIAMOND.**

A PASTEL IN PROSE.

**I.**

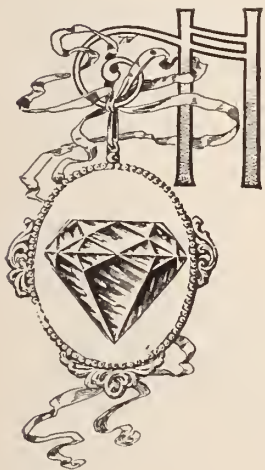

HUNDREDS of uncounted years it lies hidden from eye of man, enclosed in the baser mould in the bosom of Mother Earth, little dreaming that within its soul resides the quintessence of brilliancy and purity, and that man prizes it above all things of material value.



**II.**

In the seeking for riches, after the prospector has discovered its lair, after organized labor has delved for it and unearthed it, from a nameless pebble it is a modicum of wealth, though in aspect but a dirty mite of quartz.



**III.**

Traveling over the main, thousands of miles, it reaches the works of **OPPENHEIMER BROS. & VEITH, NEW YORK,** whose cutters and polishers lend their art, bringing forth its true nature and making it "a gem of purest ray serene," the superlative of beauty, the zenith of purity, emblem of riches, token of innocence.

# Diamonds

.. AND ..

# Diamond Jewelry

.. FOR THE ..

## HOLIDAYS.

We have an unusually large stock of mounted goods all set in the latest designs of mountings and at prices that cannot be beaten.

We have imported a large reserve stock of Diamonds, and will not advance any of our prices at present. Dealers making their selections now will have the full advantage of the low tariff prevailing on Diamonds before the Wilson Bill went into effect.

You can save 15 per cent. by buying your Holiday Stock now.

If inconvenient to call upon us, or if you have a call for some special article not in your stock, let us send you a selection package.

## Cross & Beguelin

Loose—DIAMONDS—Mounted.

17 Maiden Lane,  
New York.

43 RUE MESLAY, PARIS.

### Among the South African Diamond Mines.

KIMBERLEY, Nov. 15, 1894.—Mr. Rhodes, in the course of his interesting speech at the annual meeting of DeBeers Co., more than once expressed the hope that no more new diamond mines are looming in the distance. He was, of course, speaking in the interests of the company who have, from time to time, bought out at fancy prices concerns which threatened to interfere with their monopoly in the supply of diamonds. I do not know that any more such mines as the Wesselton, which the company had to acquire at a high figure last year, are coming into evidence, but what is generally known here is the fact that new diamond mines of one sort and another are springing up all over the country.

It is too early to express any opinion whatever on any of these concerns, but in visiting one of them the other day, I was struck with the steady improvement manifested in the mode of winning diamonds. Most elaborate machinery is now brought into requisition at mines worked upon an extensive scale. After being hauled from the shaft the diamondiferous ground is dumped on to screens of three different sizes, commencing with three inches. Thence it is conveyed to two sets of Baxter's crushers, and subsequently transferred to the first pulsator, the ground being reduced ultimately to a size of three-quarters of an inch. The ground, after the diamonds of this size have been extracted, is then reduced by a system of roller crushers to three-eighths of an inch, and is conveyed to another set of pulsators, the diamonds of this reduced size being extracted as in the former process.

The overflow from the three-eighths inch pulsator is again subjected to another process of rolling or crushing, which finally reduces the ground to cubes of three-sixteenths of an inch. The pulsators are of varying sizes in mesh, the last of them

being so small that it is utterly impossible that any diamonds can escape, and when all diamonds of any definable size have been rescued, the residue goes off in the shape of tailings. By a system of continual extraction from the different sizes of pulsators, the deposit containing the diamonds is regularly taken off to the sorting tables.

The modern crushing and pulsating plant also presents this valuable feature, that at one of the earliest stages of the whole process all worthless material, in the shape of stones, is easily picked out and thrown on one side. This is done after the ground has gone through the ordeal treatment of Baxter's crushers, so that the soil which enters the first set of rollers may be reckoned to be entirely consisting of diamondiferous ground alone. An inspection of a plant of this kind, which is to be adopted at DeBeers, commends itself to my mind as being of great advantage. There being, first, a great economy of labor; secondly, no floorage area being required, and no tedious delay in the realisation of diamond returns; and thirdly, an entire absence of handling of rich ground by natives or other irresponsible persons.

The hunting of the I. D. B. still presents interesting and amusing features. Last week I had opportunity of observing that the detectives had a rather good thing on. A pair of them diligently shadowed a shady couple up hill and down dale for the space of three hours, during sunshine, cloudy weather, hail, rain and dust. At last they were spotted by the astute female of the "Co." of two—very likely she was a "new woman"—something was seen to drop, and the worthy couple disappeared round a convenient corner. The parcel that was dropped was promptly recovered from the mire by the "tecks." It was not sugar nor tobacco, but a very pretty diamond valued at £300.

ST. GEORGE.

The use of enamel in toilet implements is a conspicuous innovation.

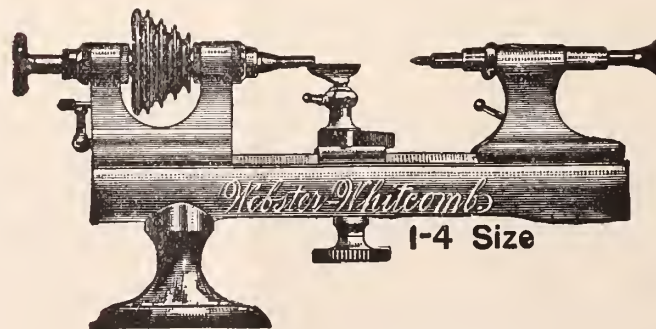

STRONGEST GUARANTEES.

Quality  
Maintained.

Prices to  
Suit the Times.

Ask for our New  
Prices and  
Terms for 1894.

## American Watch Tool Company,

Chymistry Dist., Waltham, Mass.. Stoney Batter Works.



**Exports from Foreign Countries to the United States.**

WASHINGTON, D. C., Dec. 20.—By a recent arrangement in the State Department, the Consuls-General in Canada, in Mexico, and in the various countries in Europe, transmit to the department, as soon as possible after the end of each quarter, consolidated statements showing the exports to the United States declared in their respective districts and in the consular districts subordinate to them.

In last week's issue of THE CIRCULAR, a partial list of the declared exports of jewelry, precious stones, and other lines of interest to the jewelry trade, from the different countries during the September quarter was given. The following is a complete list by countries:

<b>AUSTRIA-HUNGARY.</b>	
Amber, - - - - -	\$ 1,699.94
Art, Works of, - - - - -	8,277.38
Cutlery, - - - - -	8,532.06
Fans, - - - - -	36,787.16
Glassware, - - - - -	278,504.57
Jewelry and Precious Stones, - - - - -	84,824.25
Metal Ware - - - - -	33,655.75
Porcelain and Pottery, - - - - -	245,876.78
Scientific Instruments, - - - - -	2,179.01
Shell and Bone Ware, - - - - -	29,782.43
<b>BELGIUM.</b>	
Bronze Ornaments, - - - - -	\$ 79.09
Diamonds, - - - - -	56,204.91
Earthenware, - - - - -	1,406.22
Glassware, - - - - -	249,244.45
<b>ONTARIO.</b>	
Diamonds, - - - - -	\$ 84,621.43
Jewelers' Sweepings, - - - - -	3,960.00
<b>QUEBEC.</b>	
Antiquities, - - - - -	\$ 399.50
Jewelers' Sweepings, - - - - -	1,550.00
<b>CEYLON.</b>	
Precious stones, - - - - -	\$125.00
<b>DENMARK.</b>	
Delftware, - - - - -	\$120.60
Porcelain and Terra Cotta, - - - - -	3,810.84
<b>FRANCE.</b>	
Art, works of (paintings, bronzes, statuary and antiquities) - - - - -	\$604,232.00
Clocks and watches, and materials of, - - - - -	53,988.00
Glassware, china and earthenware and mirrors, - - - - -	375,099.00

Jewelry and precious stones, -	606,883.00
Optical and scientific instruments, -	110,944.00
Platinum, - - - - -	12,402.00

**FRANKFORT AND CONSULATES THEREUNDER.**

China, glass, porcelain, stone and earthenware, - - - - -	\$529,422.25
Jewelry and precious stones, - - - - -	61,800.08
Optical goods, - - - - -	13,585.71
Platina ware and platinum, - - - - -	51,793.54
Statuary and sculpture, - - - - -	8,562.51
Watches, clocks and watchmen's detectors, - - - - -	11,731.02

**ITALY.**

Alabaster Sculpture, - - - - -	\$ 772.00
Antiquities, - - - - -	5,395.96
Art, Works of, - - - - -	9,111.08
Bronzes, - - - - -	1,269.17
China, - - - - -	135.10
Earthenware, - - - - -	2,983.08
Filigree, - - - - -	1,203.09
Glass, - - - - -	279.22
Jewelry, - - - - -	1,461.94
Majolica, - - - - -	808.16
Marble Statuary, - - - - -	30,922.41
Porcelain, - - - - -	1,039.73
Shell work, - - - - -	18.96
Terra Cotta, - - - - -	95.00

**NUEVO LAREDO AND CONSULATES THEREUNDER.**

Onyx, - - - - -	\$ 204.00
Opals, - - - - -	750.00
Pearls, - - - - -	1,299.00

**NETHERLANDS.**

Antiquities, - - - - -	\$ 4,836.86
Balances, - - - - -	916.52
Diamonds, - - - - -	862,060.69
Earthenware, - - - - -	6,196.22
Silverware, - - - - -	11,694.37

**RUSSIA.**

Bronze Articles, - - - - -	\$ 3,023.38
Platinum, - - - - -	14,935.00
Silver Articles, - - - - -	2,260.89

**SWITZERLAND.**

Musical Boxes, - - - - -	\$ 16,621.57
Scientific Instruments, - - - - -	3,333.31
Watches and Watch Material, - - - - -	218,210.32

**BRITISH INDIA.**

Art ware (brass, copper and silver), - - - - -	\$392.46
Curios, - - - - -	385.40

Last year the Battle Creek, Mich. adventurists gave their watches, jewelry and best clothes as a Christmas offering to religion. The total footed up to \$25,000. This month they will repeat it and expect to break the record.

**Consul Downes on the Diamond Industry of Amsterdam.**

WASHINGTON, D. C., Dec. 20.—Edward Downes, United States consul at Amsterdam, Holland, reports the following to the consular department, regarding the diamond trade of Amsterdam:

"The increased tariff of the United States on cut and polished diamonds has produced a depressing effect on the Amsterdam market. For a few weeks previous to the enactment of the new law, the diamond business here was brisk; now, the industry languishes. The United States was Amsterdam's largest purchaser, and consumed about one-half of the local product. Under the new duty, the American patronage is withdrawn. The outlook for the local manufacturer, broker and operative is worse than at any time during the past year of great financial depression.

"Anticipating the advance of duty, some of the New York diamond importers opened cutting and polishing establishments in New York and Brooklyn. A few importers have become manufacturers. Since July 1, about one hundred operatives, cutters, and polishers have gone from this city and are now at work in the newly opened shops.

"Whether the injurious results of the new law on the local market will be permanent, it is yet too early to determine. If the diamond cutting and polishing industry in the United States proves a success, all the large importers may open establishments of their own.

"Whether the American diamond men remain importers or become manufacturers, one great obstacle with which they will have to contend is smuggling. The large duty of 25 per cent. the ease with which polished diamonds may be concealed, and the numberless and most ingenious methods by which concealment is secured, afford great temptations to the unscrupulous. Against the successful smuggler, neither the American manufacturer nor the American importer can compete."

His report is dated Sept. 5, 1894.

**DON'T LET A GOOD THING ESCAPE YOU.**

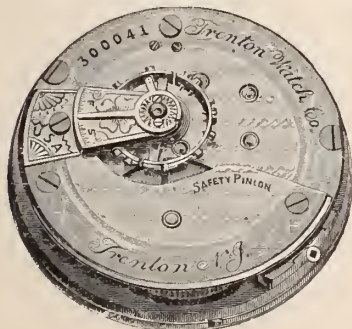

18 SIZE, 7 JEWELS.

THE REDUCED PRICE ON ALL GRADES OF TRENTON MOVEMENTS PLACES THEM WITHIN REACH OF EVERYBODY AND SURPASSES ALL COMPETITION. THEIR EVER INCREASING POPULARITY IS DUE TO THE UNIVERSAL SATISFACTION THEY ARE GIVING. THOUGH LOW IN PRICE, THEY ARE HIGH IN QUALITY.

SEND FOR ILLUSTRATED PRICE LIST, AND ORDER FROM YOUR JOBBER.



16 SIZE, 16 JEWELS.

**TRENTON WATCH CO.,**  
TRENTON, N. J.

# A MODEL FACTORY BUILDING.

THE KENT & STANLEY CO.'S MAMMOTH NEW STRUCTURE, THE  
FINEST OF ITS KIND IN THE WORLD.

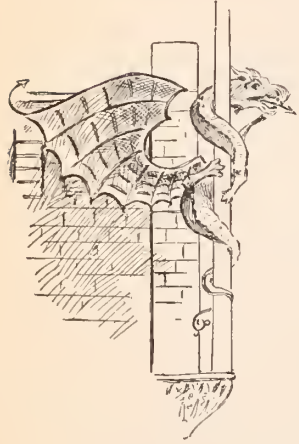

**P**ROMINENT among the many handsome factory buildings for which Providence is noted is the handsome structure built and occupied by the Kent & Stanley Co., on the Square bounded by Sabin, Aborn, Beverly and Mason Sts., in that

city. The property which it occupies was the location of the old-time popular skating rink, destroyed by fire last year. Mr. Edwin F. Kent, recognizing the advantages of the site, on his own responsibility purchased the property after the fire, though at that time the building occupied by the Kent & Stanley Co., at Eddy and Fountain Sts., was generally looked upon as a model factory, excellently planned and perfectly equipped.

Mr. Kent's foresight in the matter of the purchase of the new site was soon endorsed by his partners. Its proximity to the new railroad depot, which will be one of, if indeed not the finest, in the country is a guarantee of increasing values in that section of the city, while the increased shop room was something rendered imperative by the firm's constantly increasing business.

Work on the new structure which is depicted in one of the illustrations in this article, was begun on November 1, 1893, and October 1, 1894, the company was operating in its new quarters.

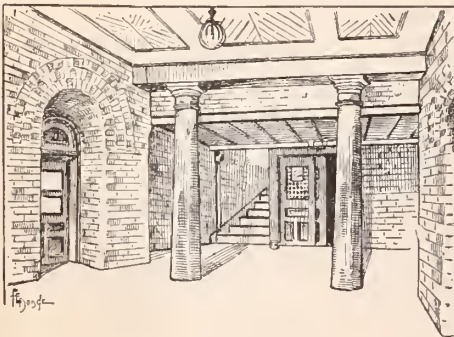

MAIN ENTRANCE ON SABIN ST.

The readers of the CIRCULAR can gather an idea of the immensity of the structure when it is borne in mind that it occupies an

acre of ground, rises seven stories above the foundation, has over 250,000 square feet of floor space, about 1,200 windows and required over five million bricks in its construction. While nearly all available space has already been leased, firms seeking modern quarters will do well to bear in mind that rentals are figured on a basis of 30 cents per square foot per annum, including power, steam heat water and elevator service.

The ground plan and character of the plot is excellently suited for the purpose to which it has been put. The L shaped formation gives it a frontage of 276 feet on Mason St., 221 feet on Aborn St., 106 feet on Sabin St., and 123 feet on Beverly St. A light well 40x200 feet extends from roof to basement in the main structure



THE KENT & STANLEY CO.'S BUILDING.

which with the additional advantage of four street frontages makes that great desideratum, good light, an assured fact for each tenant.

Red brick with brownstone trimmings was the material used for the walls, which rest on particularly solid foundations. At either corner on the Sabin St. facade are two handsome flag staffs held in place by artistic creations in wrought iron of dragons, one of which is incorporated in the initial letter beginning this article. Flags floating from these staffs bear, one, the company's trade mark on a white field and the other the national colors.

The two entrances to the building are well worthy of attention. Each shows a granite arch, while within enameled bricks of a light bluff tint please the eye and present an imperishable surface.

## THE KENT & STANLEY CO.

Our illustration shows the Sabin St. entrance with the handsome wrought iron elevator in the back ground, and two beautifully silvered supporting columns. The other entrance on Beverly St. is practically the same. Marble slabs for the names of the tenants is another feature not usually found in a factory building, and rapid running passenger elevators at either entrance afford quick access to, or egress from any floor. In the driveway running through from Sabin to Mason Sts., are two commodious freight elevators.

Floorings throughout are of maple, each floor being nearly an acre in area. The supporting columns are of iron, rising thirteen feet to the ceilings. Grinnell sprinklers and all other modern factory conveniences make the building a perfect one, whether from the view of the tenant, the insurance or the factory inspectors. Over 3 500 hands can find accommodation within its walls. Power and light are furnished by the company's private electric plant, one of the finest in the country.

The offices of the Kent & Stanley Co. are fitted up in oak, in the best taste, and pre-

sent an exceedingly attractive and handsome appearance. They occupy practically the whole of the Sabin St. wing on the sixth floor. Our illustration shows a view of the general office; adjoining it is the private office of Mr. E. F. Kent, which also connects with the director's suite.

The Kent & Stanley Co.'s shop, ever known as a model one, is in the new building better than ever. In one of the illustrations accompanying this article is shown a corner in the silver shop, a line in which the company is winning rapid recognition, and of which some of the productions, notably yachting trophies, have already been the subject of extended mention in the CIRCULAR.

A pioneer in selling its goods directly to the retail trade, the company, through its ten traveling salesmen and New York, Boston, Philadelphia and San Francisco offices offers a wide and varied line of goods. Some idea of its scope can be gathered from the fact that among them are

**THE KENT & STANLEY CO.**

One-tenth and one-quarter Gold Seamless Wire Chains; Gents' Rolled Plate Vests, all Seamless Wire, 1, 2, 3, Strand Curbs; Dickens, Trace, Rope, Single Curb, Boston



VIEW OF GENERAL OFFICE.

and Fancy Links; Red Gold and Platinum Links in all styles; Ladies' Lorgnette, Neck, Vest and Victoria Chains; 1,500 styles Gold, Silver and Plated Locketts and charms; White Stone Lace Pins and Brooches; Hair Ornaments; Chain Bracelets, Plate and Sterling Silver; Hat, Hair, Stick, Scarf and Bib Pins; Plated Sword Corsage Pins; Bracelet and Eye-Glass Chains.

In Sterling Silver Novelties, all warranted Sterling Silver are: Garters, Collarettes, Pocket Combs. Tie Holders; Belts with Silver, Pearl and Tortoise Shell Buckles, Paper Cutters and Weights, Match and Stamp Boxes, Trays, Letter Clips, Letter Openers, Book Marks, Prayer Book Marks, Thermometers and Calendars, Satchel Tags, Hat Marks, Coat Hangers, Souvenir Spoons, Umbrella Clasps, Pearl Teething Rings and Rattles, Glove Hooks, Button Hooks, Glove Stretchers, and Hat Buckles, Hair Pins in Celluloid, Real Tortoise Shell, Silver Mounted; Tooth Brushes, Shoe Horns and Letter Seals, Mirrors, Game Counters, Cigarette Cases, Sword Corsage Pins, Key Ring Chains, Bonbon Spoons, Pocket Knives, Scissors, Razors, Manicure Articles, Gold and Silver Mounted Suspenders, Novelties in Leather Card Cases, Memorandum Books, etc.; Stag Handle Cutlery Novelties, Corkscrews and many others.

The company issued last year one of the finest illustrated catalogues ever put out by a jewelry house and another is now in preparation which will be even better than

**THE KENT & STANLEY CO.**

its predecessor, if that is possible. The business of the present Kent & Stanley Co. was first established in 1873 under the style of William H. Robinson & Co.,

at 25 Calendar St. and the output consisted of chains. In 1882 Mr. Edwin F. Kent became a member of the firm and at once took an active interest in its welfare. In 1884 occurred the disastrous fire still remembered by the citizens of Providence, in

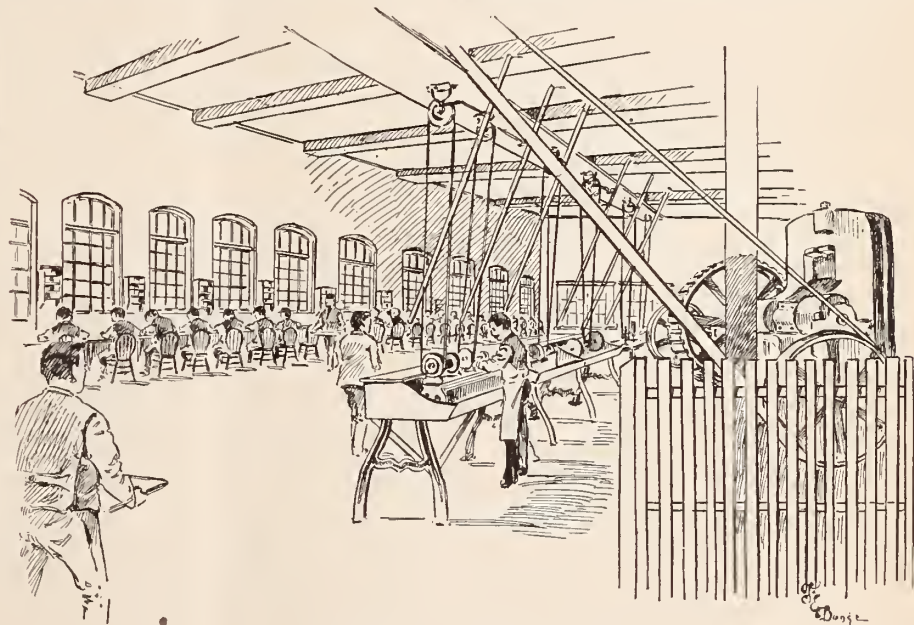

A CORNER IN THE SILVER SHOP.

which the factory was destroyed. New quarters were found at 7 Eddy St., and operations were again resumed. In 1885 Mr. Robinson died, and for nearly two years the business was conducted by the

**THE KENT & STANLEY CO.**

surviving partners, Edwin F. Kent and Arthur W. Stanley, under the old firm name. In 1887 these gentlemen purchased Mrs. Robinson's interest and continued under the style of Kent & Stanley. Under the new impetus, business during the two following years was doubled, but on Feb. 19, 1888, another fire once more interrupted operations by burning the factory entirely to the ground. Another shop was immediately found by Mr. Kent, and by noon of the day following the fire new machinery was already being put in position at the new shop, an instance of his indomitable will and prompt action in an emergency to which is due in a large measure the firm's success and high position to-day.

A lease of the ground on which the burned building had stood was quickly secured, and without the least unnecessary delay, Kent & Stanley began the erection of a building suitable to the needs of jewelry manufacturers which, when completed, ranked among the best factory buildings in the city. The firm took up its quarters in it and continued with increasing success. In February 1891, it was incorporated, under the title of the Kent & Stanley Co., being capitalized at \$300,000, represented in real property, and with charter rights for half a million. In November, 1893, the constantly increasing business necessitated larger quarters and the balance of the treasury stock was issued. In July, 1894, this additional stock had been issued, paid for in cash and invested in the new plant, which forms the subject of this article. It represents an investment of about \$350,000, and the total capital and surplus of the company in-

vested in business is \$650,000. Its officers are: president, A. W. Stanley; treasurer, E. F. Kent; vice-president, J. S. Ingalls; secretary, J. D. Warren. George R. Clarke is superintendent and designer.

## ADVERTISING HINTS FOR RETAIL JEWELERS.

BY CHARLES AUSTIN BATES.

The Editor of THE JEWELERS' CIRCULAR has asked me to contribute a series of articles on retail jewelry advertising.

It is my desire to make these articles as useful as possible and to that end, an invitation is extended to retailers to send to me any of their advertisements which they would like to have criticised. It may be that there are some questions which they will care to ask and that I can answer.

Each week I will give several examples of advertising, which will illustrate my ideas on the subject. I do not present these advertisements with the claim that they are perfect, but only with the hope that they will contain some useful suggestion, and that some dealer at least will find that by making slight changes in them, as local conditions require, they will be able to make use of them, and so relieve themselves of one detail of their business

### PART X.

**T**HERE is a disposition to take a short breathing spell after the rush of the Christmas business, but the wise advertiser will postpone this for a few days at least. There is still some business to be done with the people who have received unexpected presents, and who naturally wish to reciprocate very quickly. Proper advertising will sell a great deal of left-over holiday goods to these people.

Following that, there is an excellent opportunity for some special advertising "previous to stock taking." A little sale of odds and ends would be entirely legitimate. One of the principal problems which the advertiser of the special sale has to confront him, is that of finding a good, plausible reason—a reasonable reason, for instituting the sale. Getting the stock clean for stock taking is not only a laudable undertaking, but it can be used with good effect in the advertising. There is no need of making a great hurrah about it. It can be done in a perfectly dignified way, and is better done in that way than in any other.

Make a plain statement of the case, as if it were merely a fact which was being printed, and give the impression in the advertising that you do not particularly care to sacrifice anything, but that the loss you are willing to take is taken merely to make the work of invoicing easier. After the first of January, stock taking will be over, and it will naturally disclose a number of things which you would be pretty glad to sell at cost to get them out of the way. There is another chance for some good advertising.

I do not at any time believe in the spread eagle style. Leave that to the clothing stores and the department stores who are unwise enough to use it. A plain, honest, dignified and not too anxious statement of real facts will do a great deal more good.

\*\*\*

Taking into consideration everything, I believe that the advertising done by Tilden-Thurber Co., of Providence, is the best in the jewelry line that comes to my notice. On the 13th and also on the 17th of December, they published two large ads., each ad. with a strong and attractive design. The caption on one of them is "Useful and Artistic Gifts;" on the other "Christmas Gifts at Moderate Cost." Each advertisement has a catalogue of a large number of articles, on a great many of which the

prices are given. Almost all of the things mentioned are simple and moderate priced, just the sort of thing to supply ideas to the thousands of people who have been looking

## Gifts for Children

*Our store will be open every evening until Christmas.*

*In Sterling Silver.*

**W**E might mention desirable articles for the little ones in nearly every department. For those, however, who wish to give useful and pretty things not easily destroyed, nothing is better than Sterling Silver. To the youngest, handsome porringers, bowls and pap-spoons, cups, rattles and whistles. Then for the next older, brushes and combs, knife, fork and spoon sets, napkin rings, birthday spoons, pencils, pen holders and pocket knives. The prices are not high.

*A new spoon pattern, the Buckingham, is controlled by us.*

## Tilden-Thurber Co.

for attractive, useful and moderate priced Christmas gifts. I would be surprised very much if I were to learn that these advertisements had not brought direct and large returns.

In another corner of the paper on the same dates that these large ads. were published, the company used about six inches single column. This followed the same idea of useful suggestions that is shown in the large ads. The display is excellent, and like the matter in the ads., is dictated by common sense. I am sorry that I have only room enough to reproduce one of these ads.

\*\*\*

This fountain pen advertisement, which

was displayed in a double column, is a particularly good and striking one. Its value would be greatly enhanced if it were followed up with one or two more in the same

## ... A ... FOUNTAIN PEN

Is as much of a necessity in a man's Pocket as a Handkerchief. Doubt it? Well, we guess you never carried both. Have you seen the **LIVERMORE?** It is simple, but it works like a charm as it is correct in principle, quality and workmanship. They usually sell for \$2.00, but we have decided to sell one lot for **\$1.50**, and make you a present of a twenty-five cent bottle of ink. Remember, the pens are solid 14kt. Iridium pointed, the holders elaborately engraved, and are warranted to give satisfaction. And the price—\$2.25 to \$1.50—just one third off.

**PARKHURST, The Jeweler,  
228 BROADWAY, EVERETT, MASS.**

style, but differing slightly in matter. A fountain pen ad. would be greatly strengthened by suggesting situations in which the pen would be well nigh indispensable, and by reminding the reader of the time he loses by using an ordinary pen and inkstand.

Just about the time he gets an idea out to the end of his pen, the ink gives out, he dips the pen into the stand and loses the idea. The ink well becomes full of sediment and lint, and all kinds of foreign substances that come out on the pen and spoil the sheet of paper. There are a great many good reasons why everybody should use a fountain pen, and each one of these reasons is a good thing to put into an advertisement.

\*\*

The following advertisement and reading notice explain themselves, and offer an ex-

## SOUVENIRS FREE FOR THE G.A.R. BEAN DINNER.

Every person who calls at my store tomorrow, Oct. 13th, will be presented with A Beautiful Scarf Pin free of charge, especially designed as an appropriate Souvenir of the Bean Dinner given by T. A. Howard Post, G. A. R., on the school house commons. I have 2,000 to give away. Remember they do not cost you a cent

**HAYWARD, The Leading Druggist and Jeweler.**

### Rosedale, Parke County, Indiana.

Hayward would not be on earth unless he was enterprising and being enterprising he knows the value of advertising. When he fails to "bob up" with something new to attract public attention to "Hayward" it is no use for anyone else to try. He designed and manufactured 2,000 souvenir scarf pins and gave them away to the people who attended the bean dinner last Saturday. They were made by attaching a pin to a large Lima bean and were inscribed "Bean Dinner, Rosedale, Oct. 13, Hayward." As a result 2,000 people displayed a first-class advertisement for the benefit of the leading druggist and jeweler, of Rosedale—Hayward is in it.

cellent example of ability to turn a public happening into a private advertisement.

I notice in the advertisement of Casperfeld & Co., New York, and also in a number of ads. of Mrs. Lynch, of Union Square, New York, some bargain offers of diamond jewelry. In one instance an article is offered at \$30, said to be worth \$75. In almost every case there is a very great discount offered.

This may result in bringing present trade, but I doubt very much if it is a good thing in the long run. I doubt if it will attract the conservative buying public whose trade is most valuable. The statements made are too extravagant to be actually true. Most all jewelers recommend the purchase of diamonds because it is said that they depreciate but slightly in value. We are told continually that diamonds are a good investment. It would seem that this were not so if reputable dealers are forced to sell diamond jewelry at such great discounts as those mentioned in these advertisements. It is just this sort of advertising which makes a great many people declare that all advertising is humbuggery. Every time an advertisement which is untrue on the face of it is published, the advertising of all the other dealers in the paper is discounted. The kind of advertising that pays best always is the kind that sticks strictly to the truth. This is particularly true in the smaller cities, where there is very little floating population, and where the dealer must depend for success upon building up a list of regular customers.

For the purpose of making this department as useful as possible, correspondence is invited. If there are any problems in advertising which dealers would like to have solved, or any questions which they would like to ask, I would be glad to hear from them. It is very likely that a problem which presents itself in one town or city, will be equally present in other places, and so the inquirer will not only benefit himself, but will help many others.

The jewelry store of Mrs. Lina Baumblatt, 730 W. Baltimore St., Baltimore, Md., was robbed a few days ago of jewelry valued at \$46 25. John J. Tittle, Andreas Swartzman and William Cook were arrested, in whose possession some of the jewelry was found. They were committed for court.

On the afternoon of Dec. 15, while the clerks were busy, a sneak thief entered the jewelry store of Herman Lustig, Akron, O., and carried out two trays, one containing 20 gold and silver watches, and the other a lot of rings. Where he went and how he got away with the stolen property through the crowded street are considered a mystery.

## Letters to The Editor.

### The Silver Stamping Bill to be Introduced in the Florida Legislature.

JACKSONVILLE, Fla., Dec. 17th, 1894.

Editor of THE JEWELER'S CIRCULAR:

In reply to yours of the 6th, would say that the bill is in the hands of Senator J. E. Hartridge, who has promised to introduce it and to pay especial attention to it. The Legislature meets early in January. We will remind the Senator from time to time, and perhaps it would be advisable for you to send an official line, calling his attention to the matter.

Yours truly,

GREENLEAF & CROSBY.

### Suggestions to Obtain Silver Stamping Legislation.

BALTIMORE, Dec. 17, 1894.

Editor of THE JEWELER'S CIRCULAR:

We notice in your paper the agitation among retailers of jewelry and silver ware about a bill in Congress regulating the stamping of silver goods. We herewith wish to state to you that we are very glad to note that your paper comes out fully in favor of such a law and we assure you that we are heartily in favor of some such law.

We would suggest, however, that it would be a very good plan if the manufacturers of sterling silver goods, themselves, would write to their representatives in Congress, urging them to do all in their power to have the bill which is now before Congress, to become a law. Let a petition be started by the largest manufacturers of sterling silver goods and get the manufacturers who are in favor of such a bill to sign this petition and at the same time send in an individual petition to their Congressmen. We think at the same time that the manufacturers could have this proposed law to become a law, better than the retailers. We assure you of hearty co-operation in any way you might call upon us. Of course we are small

manufacturers, but we believe that each one can help.

Trusting you will be successful in your endeavors, we remain, Yours very truly,

STERLING SILVER MFG. CO.,

CHAS. C. STIEFF, *Sup.*

### To Cure Some Trade Abuses.

BROOKLYN, N. Y., Dec. 16, '94.

Editor of THE JEWELER'S CIRCULAR:

Probably the following verses may suggest a cure for some of the ills in the jewelry business:

### THE REFLECTIONS OF A JEWELER.

I sell umbrellas, and would sell more,  
If it were not for the dry goods store;  
Fishing tackle, too, I have quite a line,  
But the gunsmith has a larger stock than mine;  
Cut glass I have in great variety,  
But the crockeryman is jealous of my notoriety.  
Should I put in coffins, I do declare  
The undertaker would meet me there;  
The market seems to me very bare  
Of goods that no one would dare  
To compete in at my expense,  
And a search for a monopoly seems a lack of sense;  
The sky exhibits a tantalizing blue,  
Expressive of my feelings, as I view  
The crowds who rush to the other stores  
Where the fellows are not artists, only blowers;  
Now the fault is with me, or with them,  
And I will think before I condemn,  
Do I understand my business as I should?  
And refuse the bad and select the good.  
A jewelry store is a picture book,  
When well displayed the articles look  
Like artistic productions from fairy hands,  
Or beautiful selections from various lands;  
The love of the beautiful is implanted by nature  
In the minds of every creature;  
My salespeople shall be attentive  
And instructive, glad this experience to give  
In explaining the points of my selection,  
To their general excellence give direction,  
An appreciative public will me reward  
And I shall not go by the board  
So no more worry, I will take my chances,  
The truth of this every day enhances,  
Coffins or fishing tackle will annoy me no more,  
I will keep a reliable jewelry store.

W. W. S.

The jewelry stock and fixtures of J. M. Reynolds, Cohocton, N. Y., were purchased by Mrs. Reynolds, who will continue the business.

# L. SAUTER & CO.,

## Dealers in Diamonds

... AND ...

## Makers of Fine Jewelry,

194 BROADWAY, NEW YORK.



Selection Packages sent on request. Mounting of Diamonds and other precious stones in new and original designs a specialty.

# THE ARTHUR CO.,

DIAMOND MACHINERY IN THE UNITED STATES.

LEADING DESIGNERS  
AND BUILDERS OF

Machine Works, 86 John Street and 188-190 Front Street, NEW YORK.

**"See Commercial Agency as to Our Standing" Brought the Earrings.**

HOUSTON, Tex., Dec. 20.—A week or so ago J. L. Mitchell, a jeweler of this city, received a letter from an interior railway town. Signed to it was the name of a good house, and it said: "See commercial agency as to our standing." It then asked that he send some fine diamonds, as they were wanted to make a sale, and perhaps 10 per

cent. out of it. They asked for a couple of pairs of ear-drops to select from, and asked that they be sent by memorandum bill through express.

By reference to the commercial agency the firm name given was found to be first-class and the diamonds were sent, but they were not heard from as promptly as expected and the wires were put in motion. It now turns out that the stones were not

gotten from the express people by the party whose name was given, but by some one else.

**Verdict Against Jeweler Drinkwater in a Sensational Instalment Suit.**

TOLEDO, O., Dec. 20.—The jury have pronounced Lee Halter and his wife not guilty of trying to defraud jeweler E. H. Drinkwater out of the gold watch and diamond stud, which the defendants bought on the instalment plan about a year or so ago. The case was tried before Judge Hone, and occupied the greater part of two days. A number of witnesses were examined, and the case was hard fought on both sides. The jury were out nearly half an hour.

The story in detail has been aired in THE CIRCULAR. Halter bought a \$50 watch and a \$250 diamond stud from Drinkwater on the instalment plan. After paying several small sums on the account, Halter and wife left the city. After a considerable time the couple were located in Youngstown. Drinkwater thought they did not intend to pay up, and some weeks ago got out a warrant for Halter's arrest. He had himself deputized as a constable and went after his man. He ran against a legal snag, and came back empty handed. A deputy sheriff and a city detective had no better luck.

Finally a detective was put on the case. He secured the arrest of Mrs. Halter and brought her to Toledo. It is asserted that he got her into a buggy against her will and drove 15 miles across country to the city of Warren, where a train was boarded for Cleveland. The officer could not find Halter at this time. But when Halter learned that his wife had been arrested and spirited away, he came on to Toledo and gave himself up. Bail was secured for the couple and they prepared to fight the case. Halter claims that the diamond was lost and asserts that he intended to pay for it, and never intended to defraud the jeweler out of a cent.

Halter has commenced two heavy damage suits against the jeweler. Each suit is for \$10,000, one for false arrest, and the other for assault and battery.

**Bangor, Me.**

Daniel Low, Salem, Mass., has been doing quite a business in this city by mail orders.

Swett & Co., of Portland, are going out of the jewelry business at the end of this year, and are offering their stock and fixtures for sale.

The Tebbetts Jewelry Co. is the name of a new concern who have recently started in business on Kenduskeag Bridge. John Tebbetts is the manager.

E. L. McKenzie, optician, Binghamton, N. Y., has purchased a jewelry store in Greene, N. Y.

**DIAMONDS.**

**Wm. S. Hedges & Co.,**

**Importers of Diamonds,**

And Manufacturers of DIAMOND JEWELRY.

**170 Broadway, New York.**

22 Holborn Viaduct, London.

**Alfred H. Smith & Co.,**

IMPORTERS

DIAMONDS

AND

PRECIOUS STONES,

**82 BROADWAY, COR. JOHN STREET,**

**NEW YORK.**

**83 Holborn Viaduct, London, E. C.**

**R. A. KIPLING,**

**Precious Stones**

AND **Fancy Goods**

**Bought and Sold on Commission.**

**19 RUE DROUOT,**

**PARIS, FRANCE.**

**ONE YEAR'S SUBSCRIPTION**

—TO—

**The Jewelers' Circular**

—At \$2.50,—

Entitles the subscriber to a copy of "WORKSHOP NOTES" free, a 200 page book, bound in cloth, containing a fund of information for the workshop that can be found in no other work.



18, JOHN ST NEW YORK

**An Exploded Lamp Causes a Serious Fire**

JERSEY CITY, N. J., Dec 21.—A fire that for a time threatened to destroy the principal business block in Jersey City broke out at 3.15 o'clock this morning in Manuel Krause's jewelry store, 22½ Newark Ave. The fire was caused by a lamp in the show window exploding. The burning oil was scattered all over the window and the store was a mass of flames when the firemen arrived. The store was in a ramshackle two-story building, which burned fiercely.

The flames extended to Louis Drachman's millinery store at 22, L. Simon's clothing store at 24 and George T. Kimura's Japanese store at 26. Each of the buildings was pretty well gutted. Several families who lived over the stores had a narrow escape and had to flee in their nightclothes. Krause's store was almost entirely burned out. He estimates his loss at \$5,000 and has no insurance.

**Auctioneer Clough Again in the Meshes of the Law.**

HOLYOKE, MASS., Dec. 20. — Judge Pearsons had Frank P. Clough before him yesterday morning on charge of violating the itinerant vendor laws and also for acting as an auctioneer without a license. Clough's case caused considerable commotion in the board of aldermen Tuesday evening, when the petition of George H. England, jeweler, and others, was presented. He was granted a license as an auctioneer at a meeting held two weeks ago and it had been issued and signed in the usual manner. But when he began to sell jewelry and watches the storekeepers near-by found fault. They said that he was cutting into their business and that it was not right that he was allowed to do so. The board refused to revoke the license and he was thereupon hauled into court.

On the charge of being an itinerant vendor or of violating the provisions of that law he was fined \$30. He appealed and is under bonds of \$300 to appear before the Superior Court. He exhibited a mortgage on the property that was being sold, but it did not appear to impress the Judge. Clough is ready to sell his goods as soon as he is allowed to begin and says that he will sell dry goods as soon as he disposes of the stock of jewelry. The case excites considerable interest in the city.

Alfred Enderle, 36 years of age, a jeweler residing at 137 Belmont Ave., Newark, N. J., was arrested Thursday morning in an insane condition and taken to the police station. Enderle has been in the insane asylum before and made his escape once.

C. J. Kimball & Son, Manchester, N. H., have sold their business, including their late purchase of Wilbur Webster, of East Jaffrey, to Fred. H. Kimball, Charles H. Kimball and William H. Odell, who will continue the business under the firm name of C. J. Kimball Co.

ESTABLISHED 50 YEARS.

LANDEL, BAREMORE & BILLINGS,

IMPORTERS OF

DIAMONDS,

AND OTHER PRECIOUS STONES.

FINE PEARLS A SPECIALTY.

MANUFACTURERS OF

DIAMOND JEWELRY,

IN THE LATEST DESIGNS.

Diamonds Recut in Modern Styles or Repaired on Premises.

58 Nassau Street,  
29 Maiden Lane,  
NEW YORK.

1 Tulp Straat,  
AMSTERDAM.

1 St. Andrews St.,  
Holborn Circus,  
LONDON, E. C.



TRADE MARK.

ESTABLISHED 1841.

CARTER, SLOAN & CO.,

MANUFACTURERS OF GOLD JEWELRY,

No. 15 MAIDEN LANE,

NEW YORK.

A. CARTER JR.  
A. K. SLOAN.  
C. E. HASTINGS.

GEO. R. HOWE  
WM. T. CARTER  
WM. T. GOUGH.

FACTORY, NEWARK, N. J.



JOHN N. DISSELKOEN,

Gutter and Importer of

DIAMONDS

FACTORY  
73 LANGELEEKERSPAD.  
AMSTERDAM.

19 East 16th St.,  
NEW YORK.



### The Strain of Overwork Drives Manager Elmer Foster to Suicide.

CHICAGO, Ill., Dec. 24.—Terrible strain of overwork incident to the rush of seasonable business has had its tragedy. Elmer Foster, manager E. V. Roddin & Co., returned from the store to his home, Friday exhausted. Stepping into his bedroom he committed suicide by shooting himself in head. Mrs. Foster hearing the report of the revolver hastened to his side but he was past aid and died at 2 o'clock Saturday morning.

Deceased was a man of unusual business ability, was held in high esteem and was connected with the house fifteen years.

### Suits in Connection with the Gundlach Optical Co.

ROCHESTER, N. Y., Dec. 22.—An action has been commenced in the Supreme Court by H. H. Turner, John Zellwegger and John C. Reich against Ernst Gundlach for \$5,000 damages for breach of contract. It is alleged by the plaintiffs that Mr. Gundlach made a contract with them, as proprietors of the Gundlach Optical Co., to assist them in the manufacture of lenses and optical instruments, and because of his alleged failure to do so they ask damages.

Ernst Gundlach, the defendant, is probably one of the best known living opticians in the country. He came to America from Germany in 1876 and conducted an exhibit of optical instruments and manufactures at the Philadelphia Centennial Exposition. Afterward he was engaged by the Bausch & Lomb Optical Co., where he remained for several years. When the Gundlach Optical Co. were first organized he was one of the concern with the plaintiffs in this action, receiving for his services a royalty. That arrangement did not prove successful financially for Mr. Gundlach, who was compelled to sue for money owing him.

A settlement was finally effected, and the suit dismissed. A new agreement was then entered into in 1892 by which Mr. Gundlach assigned his valuable patents to the Gundlach Optical Co. and made a new agree-

ment to aid the plaintiffs in the manufacture of optical instruments and lenses, they agreeing to pay him \$40 per week during life and at his death to pay \$40 per week to his wife during her life. For this consideration Mr. Gundlach was not to devote his entire time to the business, and was not to be required to attend regularly. Under this agreement matters have not proved much better, for the company are now about \$1,400 behind in their payments to Mr. Gundlach and he has been compelled to commence an action to recover.

Mr. Gundlach's case is in the hands of his attorneys, Browning & Ross. In the answer to the complaint of the plaintiffs, Turner, Zellwegger and Reich, Mr. Gundlach denies all the allegations and sets up his counterclaim. Recently the Gundlach Optical Co. were incorporated in the names of the wives of the present members of the company.

### The Sad Death of Jonathan F. Watt.

FREEMONT, Pa., Dec. 23.—Jonathan F. Watt, formerly a jeweler of this place, died at Ocala, Fla., the 11th inst., from consumption. His many friends will be sorry to learn of his demise, as he was well liked by all who knew him. From all that the friends and relatives can learn, his remains were buried in Florida.

There is a sad history of Mr. Watt and his family. He had a wife and seven children. His wife, from disease, lost her mind and had to be placed in an asylum, leaving his mother-in-law to take charge of the family. Shortly after Mr. Watt's health began to fail and then his business went to rack. He had to break up housekeeping and go in search of health. His mother-in-law took four of the children, the two youngest and the two oldest, and lives in Westmoreland county. An aunt at Indianapolis, Ind., made a home for one daughter, having adopted her, while the other two little girls are at the U. P. Home in Allegheny.

Greenleaf & Crosby, Jacksonville, Fla., have opened their branch jewelry store in the Alcazar Hotel, St. Augustine.

### Last Week's Arrivals.

**THE CIRCULAR** has perfected arrangements for obtaining the names and hotel addresses of all the latest buyers visiting New York, and each day posts in its office, 189 Broadway, a bulletin which every member of the trade is cordially invited to copy

The following out-of-town dealers were registered in New York during the past week: C. Longine, San Antonio, Tex., Imperial H.; C. B. Jennings, Bridgeport, Continental H.; J. B. Mayer, Buffalo, N. Y., Imperial H.; J. H. Hart, Waterbury, Conn., Grand Union H.; J. Magnus, Chicago, Ill., Broadway Central H.; F. A. H. Hay, Easton, Pa., Grand H.

### The E. H. Saxton Co., of Boston, Mass., Organized.

BOSTON, Mass., Dec. 24.—The E. H. Saxton Co., 345a Washington St., this city, have organized to deal in jewelry, watches, precious stones and general merchandise.

The capital stock is \$5,000 and the promoters are Wm. H. Galloupe, Edward H. Saxton and Chas. H. Springer.

### Sears, Roebuck & Co. Can Send Their Circulars by Mail.

CHICAGO, Ill., Dec. 26.—The Government has rescinded the order of prohibition against transmission through the mails of circulars of Sears, Roebuck & Co., Minneapolis and Chicago. The firm offered free gifts for jewelry orders in an alleged lottery manner.

### Bloody Encounter With Four Desperate Robbers.

HENDERSON, Ky., Dec. 20.—Sunday night the jewelry store of Abe Hyams, of Rockfield, Warren County, was robbed of several hundred dollars worth of gold watches and valuables. Monday night three bloodhounds were utilized, and the perpetrators were tracked to a negro cabin, three miles from town.

On summons of admittance and surrender, four negroes attempted to escape, when the posse fired, killing one, wounding another and capturing the other two, who were lodged in the county jail.

J. C. Corken died in Middleburg, Fla. last week. He was a native of Connecticut but owing to impaired health had not for a number of years pursued his trade of jeweler.

### TRANSACTIONS THAT DO NOT CONSTITUTE AN ASSIGNMENT.

Where an insolvent debtor mortgaged his stock of goods to certain creditors, then immediately gave a second mortgage on the same goods to certain other creditors, and assigned all his accounts to a third set of creditors. These transactions did not constitute a general assignment for the benefit of his creditors.

*Walker v. Ross.* (Supreme Court of Illinois.)

**THE BOWDEN**  
**SEAMLESS RING**  
IS MADE ONLY BY  
**J. B. BOWDEN & Co.,**  
Makers of Finger Rings of every Description.  
REMOVED FROM BROADWAY AND JOHN STREET,  
**TO 3 MAIDEN LANE,**  
NEW YORK.





Traveling representatives may consider these columns open for the publication of any news or items of interest regarding themselves or their confreres.

BOSTON, Mass., Dec. 21.

—When President William C. Wales took his place at the head table in the Quincy House banquet hall this evening, surrounded by the guests and members of the Jewelry Travelers' Association of New England, he looked with pardonable pride into the faces of as companionable a gathering of jovial gentlemen as one ever meets.

They were assembled for a merry parting with the old year, and a confident look together into the future. Their natural buoyancy of temperament, without which no salesman can ever be a typical drummer, found free expression in hearty laughter and harmonious songs, while the feasting progressed, the merry jest passed round and orchestra music enlivened the occasion.

The guests of the association were Commodore Charles F. Morrill, Col. R. E. Mowry, of the Governor's staff, S. E. Fisher, F. B. Kennion, F. S. Sweet, David C. Percival, Jr., Joseph Battles and J. Frank Sumner, who were with President Wales at the upper table. Following are the names of the members who surrounded the other tables: Edward W. Martin, William O. Thiery, E. H. A. Pingree, F. H. Elliott, T. H. Buffum, W. S. Tiffany, John L. Shepherd, H. F. Hayes, Henry Barber, C. H. Buxton, Wade W. Williams, Robert M. Hamilton, William E. Clement, H. H. Hilton, Dean Southworth, Fred. H. Carpenter, Charles W. Finlay, H. E. Pitcher, F. E. Buffum, G. T. Howard, Mark B. Flanders, George E. Morrill, D. D. Burns, George A. Whiting, Bert Smith, Walter E. Pendleton.

After the dinner President Wales made a brief address in which he gave hearty expression to the pleasure the members felt in being permitted to get together once more, congratulating them on the large number who could say they were glad they were living, and adding a word of regret that one of the members, ex-treasurer Robinson, was separated from his comrades by sickness. He also alluded feelingly to the death of members who had been with the association when its first dinner was spread. He thanked the association for its loyalty to himself and, as individuals, to one another.

As the first speaker he introduced C. F. Morrill, who acknowledged the compliment implied in his invitation to be the guest of the association, and renewed his own invitation, which he said was always a standing one, for a midsummer cruise in the *Navarch*

whenever the association was ready to name the day. Whereupon the members assured the commodore in no uncertain tones of voice that nothing was the matter with him and he was all right.

Then John L. Shepherd was called upon and spun a few drummer's yarns. He was followed by "Bob" Hamilton, whose topic was "sample cases." E. W. Martin spoke on "the good of the order." Col. Mowry explained the difficulties in the way of China's attempt to whip Japan, and stories were told by many others.

Travelers for the different Chicago houses are talking of leaving for the road earlier than usual.

George W. Birbaum, representing Ehrlich & Sinnock, was the only traveling man who passed through Detroit last week.

Ernest Pudrith, representing Eugene Deimel, Detroit, has returned from a prosperous trip through the Upper Peninsula.

J. M. Morrow will hereafter represent the American Watch Case Co., New York, in the place of Geo. W. Mindil who will retire from the road.

I. L. Lehweh has severed his connection with E. L. Spencer & Co., Providence, R. I., and returned to the position he formerly held as traveler for D. R. Corbin, 10 Cortlandt St., New York.

Tom Hoefler, representing M. A. Mead & Co.; Tom Bristol, of C. H. Knights & Co.'s force; Commodore Coutts, traveling for G. A. Webster; Tom Wall, a Waterbury Clock man, and George Rouse, with Geneva Optical Co., make up a merry crowd of "the boys" domiciled at the Continental, southeast corner of Wabash Ave. and Madison St., Chicago.

Representatives of wholesale houses noticed in Syracuse, N. Y., during the last ten days were: Mr. Harris, for J. Goldberg; C. T. Dougherty, Sexton Bros.; Emil M. Bracher; Mr. Smith, Smith & Knapp; H. C. Barnum, Shafer & Douglas; Harry C. Larter, Hayden W. Wheeler & Co.; Mr. Kiel, White & Major; F. C. Allen, for A. Wittnauer; Richard Everett, for Clarence W. Sedgwick; E. H. Fairbrother, Burdon Wire & Supply Co.; Mr. Gregory, Strobell & Crane; Chas. Van Ness, Reeves & Sillocks; Geo. W. Smith, Carter, Sloan & Co.; Frank G. Moyer, Max Freund & Co.; Wm. L. Supple, Wm. B. Kerr & Co.; T. S. Richter, Bruhl Bros. & Co.; H. C. Schwartz, Kremenz & Co.; M. A. Sawyer.

Travelers in Pittsburgh Pa., last week were: J. Fred Crane, Mandeville, Carrow & Crane; Lou Fay, Kirby, Mowry & Co.; Stephen Woods, Battin & Co.; Lawrence H. Smith, Bippart & Co.; M. Stratton, Jr., J. W. Reddall & Co.; E. P. Hutton, Geoffroy & Co.; S. W. Abbey, E. Ira Richards & Co.; J. M. Torbert, Hall, Elton & Co.; E. L. Mumford, Waite, Thresher Co.; A. Kaufman, Bruhl Bros. & Co.; S. I. Hyman, Lewisohn & Co.; Mr. Brooks, Brooks & Pike; J. D. Barber, Landers, Frary &

Clark; J. Williams for G. Armeny; Arthur S. Holly, Towle Mfg. Co.; F. M. Wheeler, Dominick & Haff; Mr. Crane, Strobell & Crane; T. H. B. Davis, Meriden Silver Plate Co., and Mr. Gregory, Strobell & Crane.

*The American Cyclist* has the following to say of Charles F. Osgood, who many travelers will remember as representative of H. H. Curtis & Co., North Attleboro, and as member of the firm of F. H. Shearer & Co., Bay City, Mich.:

"Charles F. Osgood, son of William B. Osgood, manager of the Keating Wheel Co., of Holyoke, Mass., is a young hero with a record for life saving that is honorable to the highest degree. He is devoted to athletic and out-of-door sports, and when not using his wheel is fond of the water. He possesses a canoe, and by dextrously exercising his skill with the paddle, on October 14th saved the lives of four persons, who were capsized in a small sail boat on the Connecticut River at Smith's Ferry, Mass. On the day in question, while taking it easy on the river bank with a party of friends, he saw the boat capsize in mid-stream with its precious freight. Without a moment's hesitation he sprang into his canoe and paddled swiftly to their rescue. When he reached the party clinging to the overturned boat, he leaned forward and with efforts almost superhuman, lifted with a single hand each survivor safely into the canoe. Two of the rescued were unconscious, but were revived when brought ashore. The bravery displayed by Mr. Osgood in this single handed rescue, with a frail canoe, is highly commendable, and his skill in managing it will be appreciated by those who know how difficult it is to handle a boat of this character laden with five people. His portrait, which we present, shows a strikingly handsome, brave face. He will be awarded a medal by the Massachusetts Humane Society."

### Springfield, Mass.

S. F. Merritt has placed a fine exhibit of his eyeglass chains and holders in the board of trade rooms.

Mr. and Mrs. O. W. Bullock are now at their Winter home in California and will remain there during the cold weather.

C. A. Whitman, the Adams jeweler, fell down his cellar stairs last Thursday evening and dislocated his shoulder. Arthur Adams, of Manchester Center, Vt., is attending to the business until Mr. Whitman's recovery.

The value of a dog owned by jeweler R. B. Smith, of Woodstown, Pa., suddenly increased when the animal swallowed a gold watch and chain and a pair of spectacles.

### Maiden Lane Jewelers Beautify Their Window Displays for Christmas.

Christmas was heralded last week, as is customary, by the many tastefully and appropriately dressed jewelers' windows in Maiden Lane and vicinity.

Benedict Bros., 171 Broadway, in one window made a fine display of the Benedict buttons, the silver buttons massed and the gold buttons arranged in figures on a snow ground. A bunch of rough diamonds in another window attracted much attention.

Wm. Barthman, 174 Broadway, made his window attractive both with a fine assortment of jewelry and a clever arrangement of curved ring boxes forming geometric designs.

Many people stopped in front of the window of Jno. E. Shepard, 1½ Maiden Lane, to admire the diamond jewelry contained therein. In the center was a diamond cross and diamond floral brooch, encircled by a necklace of diamonds. These in turn were surmounted by diamond jewelry and another necklace of diamonds and turquoises.

E. A. Thrall, 3 Maiden Lane, took advantage of the opportunity which his four windows afforded to make one of the most lavish displays of jewelry to be found in the city. The first window was given over to diamond articles of all descriptions, the most prominent pieces of which were a necklace of large stones, a magnificent tiara, and two large sword pins heavily studded with diamonds. The second window showed gold and other jewelry and fine watches; silver and silver mounted novelties were contained in the third, while in the fourth were clocks, leather goods and optical goods.

Among other retail firms whose windows were worthy of mention were: O. M. Farland, 1 Maiden Lane; C. E. Mather, 21 Maiden Lane; Richard Oliver & Bloomfield, 23 John St., and C. W. Schumann, 24 John St.

A clever snow effect was obtained by nearly all the optical houses with the use of cotton batten, which served as an excel-

lent background to set off the opera and field glasses and other similar articles. Probably the most noticeable window was that of the Spencer Optical Mfg. Co., 15 Maiden Lane, where the Winter effect was heightened by the use of a large piece of crystal resembling ice. Other decorated windows were those of Henry Zimmern & Co., 37 Maiden Lane; Hammel, Riglander & Co., 39 Maiden Lane; Jno. Scheidig & Co., 43 Maiden Lane; Gustave Walter Optical Co., 33 Maiden Lane; R., L. & M. Friedlander, 30 Maiden Lane, and Julius King Optical Co., 14 Maiden Lane.

### The Disappearance of a Chain, and a Suit for its Recovery.

DETROIT, Mich., Dec. 20.—Genicke & Co., formerly Genicke & Caspary, have been sued by Agnes Dakin on rather a peculiar charge. She alleges that five years ago she went to their store on Michigan Ave. and left a gold watch chain valued at \$90, to have it repaired. Several months later she called for the chain but had no check and the clerk was unable to find it.

On the stand Mrs. Dakin positively identified Mr. Caspary as the man to whom she gave it, but that gentleman denies all knowledge of the transaction. A thorough search through the stock and records throws no light on the perplexing question. Many lawyers and Justice Schellenberg are trying to solve the problem of where the chain went to.

### Diamond Robbery Comes to Light After Three Months.

SPRINGFIELD, O., Dec. 21.—It was discovered this week that jeweler C. C. Fried had been robbed on Oct. 4th of a \$160 diamond ring. On that date a man was waited on by a clerk named Ira Wiley. A woman occupied the attention of Mr. Fried. Both were stylishly dressed. The man claimed he was Dr. C. S. Chance, of London, and said he was looking for a wedding present for a friend. He bought \$50 worth of goods and said he would call the following Friday. The couple left about the same time.

After they had gone it was discovered that the ring was missing. The man did not return on Friday and the robbery was reported to the police, with orders to keep the story away from the reporters. It was discovered that the man was not Dr. Chance. Last week it was found that George Hurliss, a Dayton diamond thief, had been here about the time of the robbery. Clerk Wiley went to Dayton and a detective brought Hurliss to headquarters. Wiley failed to identify Hurliss as he had shaven off his moustache and had a tooth knocked out. Hurliss was released, but the Springfield police think he is the right man.

### This Looks Like a New Jewelry Swindle.

NEWARK, N. J., Dec. 20.—Detectives have unearthed what appeared to be a new scheme of swindling, this week. They were called by telephone to go to 63 S. 10th St. and secure goods taken there by employes of E. H. Greenburg, jeweler, 205 Springfield Ave.

When they arrived they found one of the employes and Mr. Greenburg awaiting them, the latter explaining that in answer to an order given during the day he had sent two gold scarf pins valued at \$30, to one John Smith, at the address on S. 10th St., and when his employes had delivered the goods, the man Smith had turned over to them an alleged order for an illustrated book. This the man refused to accept in lieu of the money, but Smith would not give up the gold pins, as he claimed the book had been subscribed for on the understanding that it was to be paid for in trade.

One of the men remained in the house while the other ran to Mr. Greenburg and told the story. When the detectives heard the facts they demanded the return of the goods and Smith then gave them up. He was questioned by the officers and said that his place was in the Clinton building. Mr. Greenburg declared that his name was forged to the order blank.

# ORANGE SPOONS

Do you want a line of ORANGE SPOONS or ORANGE SETS which will give credit to your store?



RIALTO ORANGE SPOON.

OUR ORANGE SETS are put up in fine satin lined cases. Jewelers everywhere say, "The best line of goods made."

HAVE you seen our ORANGE SPOONS and ORANGE SETS? Send for special prices.



WESSELL ORANGE KNIFE.

Our New York Salesroom, 2 MAIDEN LANE, Second Door from Broadway, carries a full line of

STERLING SILVER HOLLOW WARE, NOVELTIES AND PLATED WARE.

THE HOLMES & EDWARDS SILVER CO.,  
BRIDGEPORT, CONN.

### Connecticut.

The stock in the store of John Lomberg, Ansonia, will be sold at auction.

A new music and jewelry store combined will be opened on Church St., New Britain, about Feb. 1.

The new works of the Eagle Sterling Co., in Glastonbury, are resuming full time on sterling silver goods.

Mr. Call, the well-known representative of Simpson, Hall, Miller & Co., is in Wallingford for a few days.

The Upson Jewelry Co., Waterbury, are having a lively removal sale, preparatory to removing to a new store.

Jeweler Pierpont, of Naugatuck is packing up the balance of his stock preparatory to his leaving for the far west early next week.

The Winsted Optical Co. are soon to take possession of the building formerly occupied by the Clifton hosiery, West Winsted.

Henry Grant, a Hartford clock repairer, has received information that he will soon come into possession of a large amount of English property.

The New Haven Clock Co.'s manufactory shut down Saturday night, Dec. 22d, for two weeks. On resuming, the works will run eight hours a day instead of nine as of late.

Leroy Upson, for some time assistant treasurer of the Waterbury Watch Co., has resigned and will engage in some business for himself. The duties of his position at the watch shop will be divided among the rest of the officials and the office abolished.

Scovill Hitchcock, Southington, who called a meeting of his creditors to agree upon a settlement with them, makes them an offer of 20 per cent., to be paid on or before Jan. 14. He states his liabilities as \$2,600, assets \$400. Nearly all have accepted the offer.

Eighty-five shares of stock in the New Haven Clock Co., belonging to F. E. Morgan, of West Haven, who was formerly a prominent official of the company, were attached Wednesday afternoon by Deputy Sheriff Pond in a suit brought against Morgan by the Bristol Savings Bank, to recover on a note for \$5,000 given by him in 1889.

Last week Watson J. Miller, president of the Derby Silver Co., received a private letter from Governor-elect O. Vincent Coffin, announcing Mr. Miller's appointment as an aide on the Governor's staff, with rank of colonel, with request to wire acceptance if agreeable to him. Mr. Miller wired his acceptance with suitable acknowledgments.

Simpson, Hall, Miller & Co., the Simpson Nickel Co., Maltby, Stevens & Curtiss Co. and the German silver department of R. Wallace & Sons Mfg. Co., Wallingford, shut down Dec. 22d for the usual vacation and inventory. Hall, Elton & Co. and the

sterling silver and steel departments at R. Wallace & Sons Mfg. Co. will run until next Saturday.

The United States government has, it is reported, just placed a large contract for knives, forks and spoons for the army and navy, to be made by Holmes & Edwards Silver Co., Bridgeport, out of metal furnished by the Waldo foundry. The metal is "gold-aluminum," a beautiful alloy which is selected by the government for its wearing and sanitary qualities.

Fred. Winkel's clothing and jewelry store in the Opera House block, New Britain, was broken into by thieves Wednesday night and about \$150 worth of goods was stolen. The thieves effected an entrance to the store by cutting out a large pane of glass from the rear door. The goods stolen consisted of three gold watches, 12 gold rings and a quantity of clothing.

Two bills of complaint were filed Dec. 18, in the United States Circuit Court by the Edward Miller Co., Meriden, against the Meriden Bronze Co., Augustus H. Jones, Meriden, and Willis E. Gard, Brooklyn, N. Y. One bill alleges an infringement of a patented wick raiser and the other an infringement on a valuable improvement in central draft lamps. An injunction and accounting are asked for in each suit.

### Syracuse.

Oscar Miller has opened a new store in South St., Utica.

S. H. Lesser, of A. Lesser's Sons, has left on a trip through Ohio.

M. H. Reese opened his new store at 210 Warren St. the first of the week, and put in a bid for popular favor.

Among the buyers visiting Syracuse jobbers recently were: Wm. Farrand, Savannah, N. Y.; C. J. Fuller, Phoenix; J. E. Squier, Chittenango; G. N. Lucky, Baldwinsville, and E. R. Hunt, Elbridge.

Geo. E. Wilkins says that the fine Baume & Co. tourbillon watch, which was awarded the highest medal at Chicago, and which has the unprecedented record of 91.9 marks at Kew Observatory, London, has been sold to an American gentleman.

Out-of-town buyers calling on Syracuse jobbers the past week were: J. C. Mannerling, Camillas; C. J. Fuller, Phoenix; Geo. Bergen, Earlsville; E. R. Hayden, Groton; G. N. Lucky, Baldwinsville; J. E. Squier, Chittenango; J. H. Jones, Rome; J. F. Orton, Canastota; A. H. Rose.

The estate of the late Benjamin C. Lathrop, who at the time of his death lived in this city, is the subject of litigation between two of his sons—Edwin C. Lathrop, an instalment jeweler in this city, and Levi Lathrop, of New York. The estate is valued at \$70,000, and consists of real estate in this city.

W. W. Mansfield & Co., Portland, Me., are advertising a removal sale. They vacate their store, Dec. 30.

### Philadelphia.

J. Zineman spent several days on business in New York, last week.

Riggs & Brother have issued a valuable and comprehensive nautical almanac for 1895.

Buyers in town during the past week included: Howard Fitzsimmons, West Chester, Pa.; B. C. Foster, Bristol, Pa.; H. Watson, Manayunk, Pa.; C. F. Rudolph, Wilmington, Del.

Among the salesmen in Philadelphia during the past week were: Ed. Eckfeldt, Wm. B. Kerr & Co.; Thomas G. Frothingham, T. G. Frothingham & Co.; Chas. Perret, Jules Racine & Co.

Charles Silence, Camden, and Edward Davis, 1529 Walter St., were arrested on the 17th inst. charged with stealing a pocketbook containing \$22 from the silver-ware store of Sackett & Co., 924 Chestnut St., where they were employed. One of the lads admitted the theft, and both were committed for trial.

The creditors of the optical company for whom Lawyer Hyneman is acting in the capacity of master, had a meeting at his office last week, but there was nothing definitely settled. A number of claims were presented, but there was no possibility of estimating either assets or liabilities. It is expected, however, that a dividend of four per cent. will be declared on the first audit.

John Wood, aged 45 years, a jeweler, residing on Frankford Ave., was committed to prison Thursday, in default of \$2,000 bail and a fine of \$50 on the charge of enticing girls to his place of business for immoral purposes. The warrant was sworn out by one, Mrs. Fitzpatrick who alleged that Wood had harbored her daughter Lizzie, aged 10 years, since Saturday. Wood in defense, said that he had engaged the girl to do housework, but this Lizzie denied.

### Minneapolis and St. Paul.

Frank Lueck, Minneapolis, is selling off some of his old stock at auction, at 242 Nicollet Ave., which he had stored away since last Spring.

Axel E. Madsen, North Branch, Minn. who recently started in business there, last week sold out his place to Fred. H. Eickmeier, formerly of Hankinson, N. Dak.

The Twin Cities' jobbing houses had a fair holiday trade, and for several weeks past were obliged to work their forces evenings in order to keep up with the order trade.

Out-of-town jewelers visiting the Twin Cities the past week were: Fred H. Eickmeier, Hankinson, N. Dak.; J. R. Rasset, Howard Lake, Minn.; A. E. Madsen, North Branch, Minn.; W. G. Gould, Glencoe, Minn.; E. P. Long, St. Cloud, Minn.; O. W. Peterson, Hudson, Wis.; E. A. Sawyer, Faribault, Minn.



See our  
**New Gold Links.**  
 We call them "Comfort"  
 because they deserve it.

**Lorgnettes,**  
 in Gold, Silk and Plates,  
 Plain or with Pearls or  
 Gold Balls.

**Studs, Pins and  
 Drops,**  
 in beautiful Opal, Pearl and  
 Diamond combinations

**Cane Pins,**  
 With Silver, Gold or  
 Pearl Heads, handsomely  
 chased.

**Czarinas**  
 IN SILVER AND SILVER  
 GILT.

See our dainty new line of  
**Chased Band Rings.**

In all grades, Plain, Stone  
 Set and Chased.  
**RINGS**

**A HAPPY NEW YEAR!**  
 It will surely be PROSPEROUS  
 if you handle our  
 lines.

**Waite, Thresher  
 Company,**  
 Providence, R. I.

**Waite, Thresher  
 Company,**  
 Providence, R. I.

*F. Daucke*

# The Jewelers' Circular

AND  
HOROLOGICAL REVIEW.

PUBLISHED EVERY WEDNESDAY BY

THE JEWELERS' CIRCULAR PUB'G CO.,

189 BROADWAY, NEW YORK CITY.

A JOURNAL DEVOTED TO THE INTERESTS OF JEWELERS, WATCHMAKERS, SILVERSMITHS, ELECTRO-PLATE MANUFACTURERS, AND ALL ENGAGED IN KINDRED BRANCHES OF INDUSTRY.

Our Editorial columns will contain our own opinions only, and we shall present in other columns only what we consider of interest or value to our readers. Advertising matter will not be printed as news.

Advertising rates in THE CIRCULAR are lower, considering the number of tradesmen reached by its large circulation, than in any other jewelry journal.

Notices of changes in standing advertisements must be received one week in advance; new matter can be received up to Monday.

## INFORMATION FOR SUBSCRIBERS.

### Terms of Subscription, Postage Prepaid.

	PER ANNUM.
United States and Canada, . . . . .	\$2.00
Foreign Countries in Postal Union, . . . . .	4 00
Single Copies, . . . . .	.10

New subscribers can commence at any time.

Payments for THE CIRCULAR when sent by mail, should be made in a Post-Office Money Order, Bank Check or Draft, or an Express Money Order or Registered Letter. All postmasters are required to register letters whenever requested to do so.

Pay money only to authorized collectors having proper credentials.

Returning your paper will not enable us to discontinue it, as we cannot find your name on our books unless your address is given.

In changing address always give the old as well as the new one. Your name cannot be found on our books unless this is done.

We will continue to send papers until there is a specific order to stop, in connection with which all arrearages must be paid; but such an order can be given at any time, to take effect at the expiration of the subscription. All such orders will be promptly acknowledged by mail.

The Courts have decided that all subscribers to Journals are responsible until arrearages are paid in full and an order of discontinuance has been received by the publisher.

Member of the American Trade Press Association.

Vol. XXIX. Dec. 26, 1894. No. 22.

*Every line of reading matter in THE JEWELERS' CIRCULAR, with the exception of the few brief extracts from exchanges always properly credited, is written exclusively for this journal. Each issue of THE JEWELERS' CIRCULAR is copy-righted.*

**Some Holiday** **R**EPORTS from all parts of the country reflect a large volume of business during the pre-Christmas days—considerably larger than that of the same period of last year. The outlook for trade after the holidays is promising. According to *Bradstreet's*, the Chicago jewelry jobbers have unexpectedly enjoyed a heavy trade. Throughout New England and the Middle States general trade has been of moderate proportions at most cities, being seasonably dull and in marked contrast to activity prevailing among dealers in holiday goods. A marked feature of the jewelry trade has been the large demand

for silver goods, both in the form of novelties and in table ware. This has been due to the circumstance of the reasonableness of the cost and more than commensurate showiness of silver articles. Purses have been light, but the desire for much effect in gifts has been as strong as ever; and being incapable of making purchases of objects of gold, persons have had recourse to the other well-known precious metal, silver. In this statement, it is not intended to imply that gold goods have not been in demand. As a matter of fact dealers have sold large quantities of gold jewelry, one case cited being a Boston firm who sold to one person \$20,000 worth of jewelry. It has been pointed out, however, that this prosperous condition of affairs has been confined mainly to the larger dealers, the ordinary jeweler finding his trade in clocks, silver plated ware and jewelry of a cheap character. The bric-à-brac and glass lines have been largely drawn upon, and many progressive dealers have had their enterprise in laying in a stock of these goods profitably repaid.

### Increases and Decreases in Foreign Trade.

**F**OREIGN trade for October was in many respects encouraging, total values showing an export movement in October larger than in any previous month since January. Compared with September 1894 there is a gain in value of exports amounting to 43 per cent. The gain in value of imports over those for September is about half as much. The decrease as compared with October last year in value of domestic exports is 4 per cent. and about the same relative decrease is shown from October, 1892. On the other hand, imports have developed many increases, and the gain for October this year over last is more than 15 per cent.; decreases from previous years are much less marked than with exports. The bulk of the increase in values of imports occurred in the dutiable branch. Heaviest increases among free-of-duty goods are shown in imports of raw materials, with receipts of articles of food and live animals showing heavy decreases. The reverse almost is true as regards dutiable goods, articles of food and live animal imports increasing. Raw materials imported fell off, while manufactured goods for use in the mechanical arts and for consumption, as also many luxuries, show increases. As far as the jewelry industry is concerned, imports generally show no increases in October. Of diamonds and the precious stones, the totals are as follows: 1894, \$529,406; 1893, \$538,183; the falling off in 1894 being in diamonds and other precious stones, rough and uncut, including glaziers' and engravers' diamonds, not set, and jewels to be used in the manufacture of watches, the figures being, 1894, \$5,780; 1893, \$66,879. This latter condition is due to the excessive imports of rough stones, prior to the enactment of the

new tariff law. Imports of clocks and parts of showed a marked increase, the figures being \$45,146 in 1894, and \$22,449. This increase has been doubtless due to the renewed activity in the sales of clocks generally, which for three years previous to the present had considerably fallen off. Of watches and jewelry the figures were practically equal; of the former, \$115,601, in 1894, and \$121,935 in 1893; of the latter, \$64,733 in 1894, and \$65,489 in 1893. As to exports, clocks and parts of alone show an increase; \$85,688 to \$71,717. Of watches the decrease was marked, namely, \$32,426 to \$54,966; jewelry decreased about 25 per cent., namely, \$44,045 to \$62,190; plated ware, about 15 per cent., \$27,732 to \$32,342. These figures, however, should be compared with averages, to obtain a more correct deduction as to relative increases and decreases.

### The Wonder of Precious Stones.

**T**HERE is something specially interesting and attractive about precious stones. They are certainly the most beautiful objects in the mineral world. To one who loves the charm and harmony of color they are a joy forever. What can equal a matchless diamond? In a small space you carry about with you all the hues of the rainbow. Light a taper and immediately a thousand rays flash forth, and delight you with a feeling of power and possession. They are all yours and neither grow old nor fade away. Five hundred years hence this matchless stone may grace the hand of your fair and youthful descendant and flash out as brilliantly and freshly as it does to-day—a bond of sympathy between her on earth and you in spiritland, to which a mesmeric virtue may be attached, linking past and present together, mortal with immortal; for in precious stones there always seems to be something vital and mysterious.

**I**T may be appended to the summary of achievements in the obtaining of silver stamping legislation in various States of the Union, published on this page in the last issue, that in Florida the common bill drafted by THE CIRCULAR has been placed into the hands of a State Senator who has promised to introduce it and pay especial attention to it. It is to us a matter of great satisfaction that the trade have acted their part in this connection with so much earnest interest.

### The Will of Andrew Ingraham Makes Many Bequests.

BRISTOL, Conn., Dec. 24.—The will of Andrew Ingraham, one of the founders of the clock industry in this country, makes many public bequests. He directs that a valuable section of land be sold and the proceeds divided equally between the American Missionary Association, the Connecticut Bible Association, the town of Bristol for library purposes, and the American Home Missionary Society.

### New York Notes.

Judgments for \$211.22 and \$162.01 have been entered against Abraham Grinspan, in favor of Solomon Jacobson.

Chas. Hauscheldt, 432 W. 42d St., has renewed a chattel mortgage on jewelry fixtures for \$304 to A. Goldsmith.

R. R. Fogel, of R. R. Fogel & Co., 177 Broadway, has been elected master for the ensuing year of Star of Cuba Lodge 742, F. & A. M.

Wm. B. Durgin, Concord, N. H., and C. Dorflinger & Sons, 36 Murray St., New York, have applied for membership in the New York Jewelers' Association.

A quantity of jewelry, diamonds, pearls and watches were among the goods disposed of at the auction sale of seized and unclaimed articles held at the Barge office, Wednesday. Fair prices were realized.

The General Term of the City Court last week handed down an opinion reversing the judgment for \$745.83 entered July 9, 1894, by Freudenheim & Abramson against Julia Raduziner, and ordering a new trial of the action.

The motion to make permanent the temporary injunction recently obtained by the Wm. Rogers Mfg. Co. against Wm. A. Rogers, of Brooklyn, restraining him from having his name placed on silverware, was to have been argued before Judge Lacombe, in the United States Circuit Court, Friday, but was postponed until Dec. 29th.

Examiner Krebs, of the jewelry department of the Appraiser's stores, was before Collector Kilbreth, Thursday, to explain the disappearance of a valuable diamond ring which vanished from his division on October 25 or 26 and has not been found. Mr. Krebs denied all knowledge of the missing jewel and the Collector made no decision in his case.

An attachment was issued in this city last week against the Wymble Mfg. Co., on a claim for \$691.19 in favor of Geo. T. Bynner, New York, representative of the company. The attachment grew out of a misunderstanding in relation to the amount due Bynner, and was obtained on the ground that the defendant company was a foreign corporation. The matter was settled amicably and the attachment vacated.

Tudor Angel Myers, formerly a dealer in diamonds at 51 Maiden Lane, secured a verdict Thursday before Judge Patterson, in the Supreme Court, for \$3,375. This sum was the full amount with interest and costs, claimed in a suit against Harry Phillips, who was charged with having obtained \$3,000 worth of diamonds in the latter part of 1892 from the plaintiff on false and fraudulent representations.

At a meeting of the Central Labor Union, in Brooklyn last week, representatives of the Diamond Workers' Union asserted that the statements made by a number of importers and manufacturers before the immi-

gration authorities in relation to the question whether or not their industry was new in this country were not based upon facts, and it was resolved to collect evidence to substantiate the charges made by the diamond workers.

Mary Day Dominick, the mother of H. B. Dominick, of Dominick & Haff, died Tuesday, Dec. 18th, at the age of 73 years. Mrs. Dominick was the widow of the late Jas. W. Dominick. Her death was due to bronchitis, from which she had been suffering but two days. Her health for some time previous, however, had not been good. The funeral services were held Thursday, at the residence of her son, H. B. Dominick, 14 W. 49th St. The remains were interred at Woodlawn Cemetery. Mrs. Dominick was a woman of the most lovely character and Mr. Dominick has the heartfelt sympathy of his friends, in his affliction.

The trophy for the winners of the American National (bowling) Tournament, which is being rolled at the Germania Alleys, was exhibited last week by its makers, the Wilcox Silver Plate Co., in the window of their store, 6 Maiden Lane. The design is appropriate, consisting of three bowling balls, on which rest three pins, forming a tripod and supporting a large egg shaped cup. The cup is decorated with the American shield and surrounded by a horseshoe, bearing an inscription, on the top of which is a gilt eagle.

David Goldstein, retail jeweler, 651 Ninth Ave., was arrested Dec. 16th, charged with attempting to collect a fraudulent insurance claim. It is alleged that on Aug. 30, a fire occurred in his store, on which he had insurance amounting to \$3,500. Fire Marshal Mitchell declares that the stock was worth only about \$1,100, and says that fires occurred under suspicious circumstances in four other places occupied by Goldstein. The prisoner was arraigned before Judge Martine, in General Sessions, and was released in \$3,000 bail.

Wm. Sinclair, an elderly man, pleaded guilty to the crime of petty larceny before Judge Fitzgerald in General Sessions, Dec. 18. There were two indictments for grand larceny in the second degree pending against him, one charging him with stealing 12 and the other 17 silver umbrella handles from Schloss Bros., of 620 Broadway, on Nov. 5. Sinclair is said to be an Italian whose real name is Mario de Benedetti. It is claimed that after serving several terms of imprisonment in England, he came here in 1892 and was almost immediately arrested for shoplifting in Maiden Lane. The Italian Consul, however, procured his discharge.

William Ginnel Simmons, the second son of Francis R. Simmons, of Henry Ginnel & Co. and grandson of Henry Ginnel of that firm, died Friday at the age of 19 years. His death was due to a heart trouble from which he had been suffering for some time. The young man had recently entered as a

student at the College of Physicians and Surgeons, of this city, and was a graduate of the Brooklyn Polytechnic Institute. He was an accomplished musician and had spent much time in the study of music. A large number of relatives and friends attended the funeral services which were held Sunday afternoon, at the residence of his parents, 260 Union St., Brooklyn.

### A. K. Sloan's Fishing Story Uniquely Remembered.

The day subsequent to the last annual banquet of the New York Jewelers' Association, C. E. Hastings, of Carter, Sloan & Co., gave a dinner to a few select friends at the Lawyers' Club, in the Equitable building. The party consisted of Charles W. Bailey, of Bailey, Banks & Biddle Co., Philadelphia, Pa.; Clem Weaver, of J. E. Caldwell & Co., Philadelphia, Pa.; R. H. Galbreath, of the Duhme Co., Cincinnati, O., and A. K. Sloan and Geo. R. Howe, of Carter, Sloan & Co., New York.

The sextette enjoyed the charming lunch, not only because of its gastronomical beauties, but also by reason of its anecdotal features. Mr. Sloan entertained his companions, upon request, with a vivid account of his notable fishing trip of last Summer, when with E. C. Fitch, president of the American Waltham Watch Co., he passed on the latter's yacht some interesting weeks on the river Romaine, in Labrador. The rehearsal of this story had a peculiarly impressive effect on Mr. Bailey, as the subjoined letter will evidence:

DECEMBER 21ST, 1894.

*My Dear Mr. Sloan:*

Although many days have passed since I attended the charming lunch at the Lawyers' Club, it is impossible to erase from my memory the most interesting story of your fishing trip last summer. Night after night I have remained awake, trying to grasp the circumstances depicted by yourself, until unable longer to stand the strain on my nervous system, I conceived the idea of placing on paper the visions as they appeared in my troubled sleep. When you thoroughly peruse the little souvenir which I send with my most sincere regards, you will probably be surprised at the close resemblance of my imaginations to the exact facts, as you experienced them. I agree with you that killing salmon (as seen in my visions) must be magnificent sport.

In a few minor details the sketches may not be correct, but they are so realistic you will probably imagine yourself once more in Labrador (wherever that may be)

Wishing you and all the firm a Merry Christmas, I remain,

Sincerely yours,

CHAS. W. BAILEY.

Accompanying the letter was a unique specimen of bookbinding, as beautiful souvenir as one could conceive. It consists of seven card boards bound within a white, antique linen paper cover, the boards being held by a red ribbon. The fishing trip is illustrated with humorous color sketches showing decided talent in their execution, while the reading matter in hand printing, is written in burlesque style. The volume is titled "A Story," and reflects much credit upon its designer, though it is evident he is not an unquestioning believer in fishermen's tales.

**L. TANNENBAUM & Co.,**  
IMPORTERS AND CUTTERS OF

**Diamonds and Precious Stones,**

Cor. Maiden Lane & Nassau St.

**NEW YORK.**

25 Hatton Garden, London.

TELEPHONE, LONG DISTANCE 1959 CORTLANDT.

## Special Announcement.

Mr. L. Tannenbaum begs to notify his customers and the trade in general, that he has largely extended his facilities for cutting and polishing. Hereafter he will cut and polish not only RUBIES and SAPPHIRES, which has been done for the past 15 years with increasing and gratifying success, but

# DIAMONDS

and all other stones which undergo this process.

Modern machinery of the best and most approved pattern, and workmen of the highest class will enable Mr. Tannenbaum to offer, direct from the cutter's hands, that excellent workmanship demanded by American buyers, at

## PRICES THAT DEFY COMPETITION.

Nor will buyers of Diamonds be the only people benefited. Mr. Tannenbaum imported a five years' supply of rough Rubies and Sapphires DUTY FREE under the old tariff. These goods are now being cut and polished and it is very evident that in these particular stones he can make UNAPPROACHABLE PRICES.

New York as the future Diamond Market is not a phantasy. American cutters will be shown an assortment of rough, at prices which will perhaps cause them to believe that this has already been brought about. All arrangements have been made by the firm for enormous shipments of DIAMONDS, EMERALDS, PEARLS, SPINELS, CATSEYES, MELLES and all kinds of Precious Stones, although to-day the assortment offered by L. Tannenbaum & Co. ranks second to none in this country.

☞ **HIGHEST PRICE PAID** for all AMERICAN PEARLS and OTHER PRECIOUS STONES.

### Providence.

R. G. Shutz, salesman for E. L. Logee & Co., has severed his connection with that concern.

Walter A. Griffith has been elected Chancellor Commander of Sterling Lodge, Knights of Pythias.

Mrs. Charles H. Fuller left last week for California, whence after a short stay she will sail to Australia.

The retailers in this city enjoyed one of the best holiday weeks that has been experienced in several years.

Mr. Tuck, of the jobbing house of Tuck & McAllister, has returned from a trip through New England.

A quarterly dividend of 1½ per cent. upon the preferred stock of the Gorham Mfg. Co. has been declared payable Jan. 1st.

E. J. Knight & Co. have opened an office in room 21, 87 Weybosset St., for the sale of diamonds, watches and jewelry on the instalment plan.

Mrs. Nanie E. Holt, widow of the late Albert Holt, has applied to the Municipal Court to be appointed administratrix of the estate of her late husband.

George Angell, formerly representative for Frank T. Pearce & Co., has severed his connection with that concern and accepted a similar position with E. L. Logee & Co.

Samuel H. Brower who has conducted a jobbing business at 226 Eddy St. for several months, is closing out his stock and will enter the employ of R. L. Griffith & Son, as traveling representative.

The pedestal for the statue of the Gladiator which George Wilkinson has presented to the city is nearly completed and the bronze will probably be set up at Roger Williams Park during the coming week.

Richard Robinson, who for several months the earlier part of this year carried on the manufacturing jewelry business, but failed some weeks ago, has entered the employ of Frank T. Pearce & Co., as traveling salesman.

William J. Wallace, who was caught stealing gold clippings from Waite, Thresher Co., was indicted last week. He pleaded *nolo contendere* and his case was continued for sentence on his furnishing bail to the amount of \$500.

The business heretofore conducted by Alfred Williams and James H. Presbrey under the style of Presbrey & Williams, 53 Clifford St., was dissolved on Dec. 20th by mutual consent. The business will be continued by Alfred Williams.

The E. H. Reynolds Co., gold plate manufacturers, after an occupancy of more than a decade, are removing from the Penholder building at the corner of Dorrance and Friendship Sts., to the shop formerly occupied by J. F. Hopkinson & Co., at the corner of Page and Friendship Sts.

The McCormick Co. are making preparations for removal into new and larger

quarters adjoining their present office in the Butler Exchange building. This will increase their capacity nearly four times what it is at present, and the new offices will be furnished with new and handsome fixtures including two large safes.

Under date of Dec. 17 the following was published in the Providence *Journal*: "Notice is hereby given that the co-partnership formerly existing between George H. Richardson, Elwood J. Fisher, M. A. Frances Fisher, and Florence F. Lamb, under the firm name of William M. Fisher & Company, was dissolved on April 7, 1894, by mutual consent. The business of the copartnership was from the date named continued by George H. Richardson and Elwood J. Fisher, who assumed payment of all liabilities." This is signed by M. A. Frances Fisher and Florence Fisher Lamb. This notice was issued since the death in New York of George H. Richardson.

After a lingering illness since August last Joseph B. Wentworth, one of the best known journeymen jewelers in this city, died Thursday at his residence in this city, in the 47th year of his age. He was born in Boston, Mass, March 13, 1847. He came to this city and was employed for several years as a machinist. Eight years ago he entered the employ of R. L. Griffith & Son as tool-maker and foreman. He remained with this firm until about four years ago, when he entered the employ of George Holmes & Co., as foreman. It was the deceased's intention of entering the manufacturing jewelry business for himself in January, 1895. He was a prominent member of the American Mechanics, Knights of Pythias, Grand Army of the Republic, United Workmen and Knights of the Golden Eagle. His funeral occurred Monday, and was largely attended.

### Pittsburgh.

Albert A. McFarland has opened an engraving shop at 54 Fifth Ave.

J. C. Stumpf has bought out the store, stock and fixtures of A. C. Allen, Franks-town Ave.

The new Diamondtine Co. have opened an attractive establishment on Fifth Ave., adjoining the *Leader* office.

Frank Worrell, the well-known jeweler of Washington, Pa., surprised his friends last week by getting quietly married.

The business of the past week has been a rushing one, and must leave some happy impression on jewelers' exchequers.

Among visiting jewelers last week were: B. Neville, Dawson, Pa.; P. J. Mauson, Smith's Ferry, Pa.; J. D. McAulis, Beaver Falls, Pa.; Frank Worrell, Washington, Pa.; and George V. Brady.

G. L. Ruff, Penn Ave., is regretting the loss of a \$90 solitaire bought on time by the cleverest swindler of the age—one Roberts—a handsome, slick individual who has recently "done" our most prominent merchants.

### New York Notes.

(Continued From Page 22.)

An order from Washington received in this city Friday, directs the return of the diamonds and jewelry which customs officers seized on Dec. 9 from José Avandano, a passenger on the steamship *La Champagne*.

S. L. Von Wezel, of Amsterdam, Holland, arrived Saturday on the *Lucania*. Mr. Von Wezel comes here in the interest of the diamond cutting business he is about to operate in this city. His diamond cutting factory is located at Elizabeth and Bleecker Sts.

Henry Fera, 10 Maiden Lane, who recently purchased the diamond cutting factory at 60 Fulton St., which was originally to have been opened by Jno. H. Disselkoe, expects to have it in operation by to-morrow or the following day. He will operate 12 mills here, in addition to the three already established at 10 Maiden Lane.

Frank Collier, an employe of the Gorham Mfg. Co., was arraigned in Jefferson Market Court, Friday, charged with stealing \$20 worth of silver spoons from the establishment. William L. Le Cato, manager of the firm, appeared against him. Collier was held for trial.

George H. Allen, a jeweler, 32 years old, of W. 44th St., attempted to board the front platform of a down-town Broadway cable car Saturday morning, when he slipped and fell so that his foot got caught beneath the fender. He was removed in an ambulance to Roosevelt Hospital. Michael Mollahey, the gripman in charge of the car, was arrested, but discharged in the Yorkville Police Court.

### The Appeal From the Decision in the Diamond Cutters' Case.

Superintendent of Immigration Stump and Assistant Secretary of the Treasury Hamlin, Saturday heard arguments on the appeal from the decision of the Special Board of Inquiry which, as published in THE CIRCULAR last week, ordered the release of A. Hoed, a diamond polisher alleged to have been brought here in violation of the Contract Labor Law. By the decision of the Board of Inquiry they declared diamond cutting to be a "new" industry within the meaning of Section 5 of the statute and therefore exempt from this law.

The dissenting commissioner appealed from the decision of his three colleagues and, as before stated, argument on this appeal was commenced at Washington, Saturday. The argument will be continued during the coming week.

Charles A. Veicht, Milwaukee, Wis., has assigned. Bond for \$3,500 attached.

Since the first of October, the Manhattan Silver Plate Co., Lyons, N. Y., have run until 9 o'clock every night, the force numbering 250 persons. This fact is sufficient to prove that the company are enjoying an enviable spell of prosperous business.



**The Latest Patents.**

ISSUE OF DEC. 18, 1894.

**530,915. JEWELER'S PRESS.** CHARLES M. ADAMS and GEORGE W. ADAMS, Providence, R. I. Filed Dec. 26, 1893. Serial No. 494,717. (No model.)

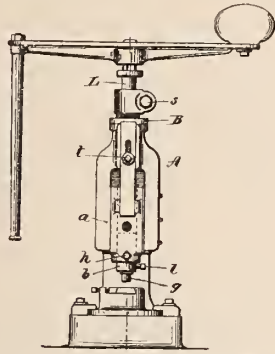

In a screw press, the combination of two sliding punches operated by the same screw and sliding one in the other, the outer plunger having a recess through it, and a recess in the front of the inner plunger having projecting edges at the lower edges of the recesses in the plungers and the upper side of the recess in the inner plunger beveled away, a front plate adjustably attached to the press standard and having a recess in its lower end the bottom of which projects inward and the upper side of which is beveled away, a block fitted to slide in the recess in the outer plunger and having its ends beveled.

**530,927. HAT-PIN.** OSBORN CONGELTON and GERTRUDE R. BOYD, Philadelphia, Pa., assignors of one-third to Oliver H. Bair, same place. Filed Jan. 16, 1894. Serial No. 497,050. (No model.)



A hat pin, comprising a rectangular guide frame, slides arranged on the opposite ends of the guide frame and having side pieces to run on the sides of the guide frame, the said slides being provided with depending inwardly extending prongs and a spring connecting the oppositely arranged slides and normally drawing them toward each other.

**531,002. ELECTRIC PROGRAM CLOCK.**

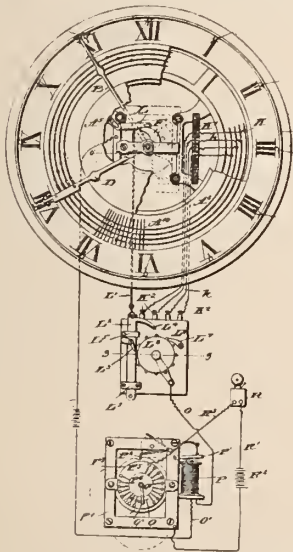

JOHN L. McCASKEY, Waynesborough, Pa., assignor to Frederick Frick. Filed Sept. 13, 1893. Serial No. 485,410. (No model.)

**531,051. METHOD OF SECURING DIAMONDS IN STONE-CUTTING TOOLS,** RUDOLF MARQUART, New York, N. Y., assignor to himself [and] Charles Brandt, Jr., same

place, and Edward B. Tompkins, Brooklyn, N. Y. Filed Aug. 3, 1894. Serial No. 519,348. (No specimens.)

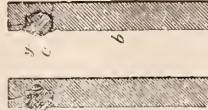

The method herein specified of securing diamonds, and other stones in implements for cutting stone the same consisting in making a cavity or receptacle in a piece of metal, inserting the diamond into the cavity, heating the metal with the stone in place and filling in the interstices around the stone with a molten brazing metal or solder which unites with the metal and then pressing and forcing the hot metal and brazing metal from without around and over upon the stone to securely hold the same in place.

**531,095. EYEGLASS FOLDING FRAME.** ALFRED BRUNNER, Laupen, Switzerland. Filed Oct. 2, 1894. Serial No. 524,745. (No model.)

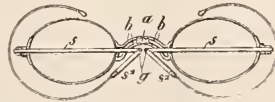

The combination with a pair of eyeglass frames connecting by a foldable bridge, of temple bows, each composed of a rigid and a spring section articulated together, said spring section bent into a loop and adapted to encompass the eyeglass frames when folded.

ISSUE OF DEC. 11 (OMITTED)

TRADEMARK **25,663.** CATALOGUES AND NEWSPAPERS. F. M. SPROEHNLE & CO., Chicago, Ill. Filed Nov. 6, 1894.



*Essential feature*—The words "OUR SALESMAN" and the conventional figure of Uncle Sam. Used since January, 1894.

**Canada and the Provinces.**

Retail jewelers of Halifax, N. S., report a good Christmas trade.

Aston & Tobin, jewelers, Pictou, N. S., have had the interior of their store painted to good effect.

W. C. Gibson, jeweler, St. Johns, N. B., has compromised with his creditors at 35 cents on the dollar.

Fire destroyed the buildings in the business portion of the town of Springhill, N. S., on Friday morning and among those who suffered loss were Frank Bird, jeweler, and E. Longeville, watchmaker. Mr. Bird carried no insurance.

Robbers smashed the plate glass windows in Bowen's jewelry store, Quebec, at 2 o'clock on the morning of the 16th inst., and carried away gold and silver watches, also a large number of rings, the whole valued at several hundred dollars. Detectives are looking for the robbers.

George A. Gray and Joseph N. Babson, doing business under the name of the Canada Plating Co., 763 Craig St., Montreal, assigned Thursday. Although there are about 50 creditors, they are in small

amounts, the largest being the Molson's bank secured \$750; J. H. Timmis, \$293; W. McLaren & Co., Guelph, \$165, and Thomas Tribey & Co., \$400.

William H. Newman died at his home in Dartmouth, near Halifax, N. S., on Dec. 18th, of apoplexy of the brain. Mr. Newman went to Halifax in 1855 and entered into partnership with J. Cornelius in the jewelry business. After some years the firm dissolved, each partner going into business on his own account, which state of affairs has continued since. Mr. Newman was highly respected as a business man and citizen of Halifax. He leaves one son who is interested in the business.

**Boston.**

Charles May will remove early in January into more commodious quarters, taking the second floor room formerly occupied by the Bay State Watch Case Co., which gives him an entrance from 3 Franklin St., as well as 386 Washington St.

Rich & Baker, 40 Bedford St., announce that on account of their rapidly increasing optical trade, they are about to close out their other departments, and will give up the sale of jewelry, watches and silverware after the first of the year.

Howard Beatty, age 17 years, employed by Shreve, Crump & Low Co., is held for trial charged with the larceny of a tray of comb jewelry, which was missed from his samples by a salesman for a New York concern, after he had exhibited them to the firm's buyer. He discovered his loss when he opened his satchels at his next calling place. Search for the tray failed to bring it to light, but the police found the missing stock in a pawnshop. Beatty answered the description given by the pawnbroker. When arrested he admitted his guilt.

The price list of the Webster-Whitcomb lathes and the attachments therefor, made by the American Watch Tool Co., Waltham, Mass., for January, 1895, has just been issued. It will be received by the trade with great interest, owing to the number of reductions shown on the prices of articles enumerated. As these reductions indicate no depreciation in quality, and as the company guarantee that there will be no falling below the high standard their goods have ever maintained, no slight benefit will accrue to the trade by these changes. The illustrations, numbering about thirty, include the Webster-Whitcomb lathes with and without tailstock, heads, jewelry rests, slide rests, chucks, and wheel cutting and other attachments. It is not claimed by this company that the Webster-Whitcomb lathes are the cheapest, but they call attention to the fact that as these lathes were the first as were taken abroad to be copied, and as over 8,560 are now in use, it is almost unnecessary to point out that they will be found to be the most satisfactory and, therefore, the cheapest in the end.

## News Gleanings.

Burt Chalker will go into the jewelry business in Southington, O.

Willis Isaacs will remove from Russellville, Pa., to Hoboken, N. J.

Philleo Bros., Alexis, Ill., have opened a branch jewelry store in Cable, Ill.

On the first floor of Hefferman's new block, Spencer, Mass., is Isaac Achim, jeweler.

C. E. Willson, Deckertown, N. J., will on Jan. 1, move to the A. E. Ayers' building, on Main St.

John L. Clevlen, Poplar Bluffs, Ia., has sold out to Geo. W. Cameron, who takes possession Jan. 1.

J. E. Parker, jeweler, Morristown, N. J., sustained a loss by water in a fire in the Babbitt building, Dec. 20.

M. M. Simmer, Northfield, Minn., has sold out to Nels Petersen, who has been in charge of the business for some time past.

Noyes & Johnson, Marinette, Wis., have dissolved partnership. Mr. Noyes takes the drug stock and Mr. Johnson the jewelry stock.

G. A. Oppel, Little Falls, N. Y., has moved from the Collins block to the block erected by himself on the south side of Main St.

E. S. Cohen, assignee of Allward & Pearson, jewelers, Colorado Springs, Col., began to sell the stock at auction last Saturday.

E. A. Williams, Lynchburg, Va., announces that he will dispose of his jewelry stock and apply himself exclusively to his optical business.

Burglars raided Wyoming, Pa., some days ago, and among other places entered was the jewelry store of B. O. Dodson. A few articles were taken.

Burglars broke into W. A. Gay's jewelry store, Elliott, Ia., recently, while the proprietor was at supper and carried off about \$500 worth of watches and jewelry. This is the second raid on this store within a year.

John Leonard went into Wm. Kendrick's Sons' store, Louisville, Ky., last Saturday night and tried to walk off with a fine ring that was shown him by the clerk. He was fined \$20 and placed under \$1,000 bond for 12 months.

Otto W. Andrae, jeweler, San Antonio, Tex., whose assignment was announced in last week's CIRCULAR, named Dr. G. G. Clifford as assignee. Dr. Clifford filed a bond of \$10,000, but as yet no statement of assets and liabilities has been made.

Between 3 and 4 o'clock of the morning of Dec. 12, a most terrific cyclone swept over Monroe county, Ga., devastating Forsyth and the country generally. W. E. Sanders' jewelry store was demolished and great damage was done to the stock.

R. F. Gresham, a jeweler, who was ar-

rested in Portsmouth, O., some time ago and taken to Georgia on requisition papers, writes to friends in Portsmouth that he easily cleared himself of the charge, and that he has gone into business in Atlanta.

Two negroes entered the Shontz jewelry store, Des Moines, Ia., one night last week, and asked to see a diamond ring. After examining it they laid down a bogus ring, saying they did not want it. When the proprietor demanded his ring they drew a revolver and fled.

C. C. Brown has been discharged as the assignee of the George Chatterton jewelry house, Springfield, Ill. The order was entered on a petition which set forth that all claims and indebtedness had been paid, and that Mr. Chatterton was prepared to again take hold of the business.

The jewelry store of H. W. Swartz, South Side, Scranton, Pa., was broken into at an early hour last Tuesday, and a number of watches and all of his working tools stolen. The thieves gained entrance through a window in the back of the store by removing the sash.

At an early hour of the morning of Dec. 16, one of the show windows of J. H. Flanagan's jewelry store, 531 7th St., Washington, D. C., was smashed and about \$100 worth of plated silverware stolen. A brick wrapped in a coat was found in the window after the robbery was committed.

As Lewis Creamer, aged 45, a peddler of silverware and jewelry, living in Bound Brook, N. J., was going into New Brunswick last Saturday night a large and powerful negro who passed him suddenly turned and struck him, knocking him down. The negro then beat and kicked him into insensibility, and took from Creamer \$18 in money and about \$40 worth of silverware.

Milford, Del., is talking over a marriage which occurred there a few days ago. At the last session of the General Assembly, Charles Davidson, a jeweler of that place, was divorced from his wife. She asked for the divorce on the ground of cruelty and it was granted. Recently he wooed and won her back, and a few days ago they were married by the Presbyterian minister, at Milford.

What might have been a serious fire was narrowly averted at Malden, Mass. a few days ago. Fire was discovered in a factory on Middlesex Court, used by George M. Tilson for the manufacture of tin specialties and cheap jewelry. The building is in the midst of a collection of wooden buildings, near the center of the city, and but for the prompt action of the fire department a serious conflagration might have ensued.

A large plate glass in the show window of Hope Bros. & Arnold, jewelers, Knoxville, Tenn., was broken about 9 o'clock the morning of Dec. 14. Walter Kennedy, the store porter, had gone out to clean the window, and was standing on a ladder, when he lost his balance and fell against the pane. The force of his fall was so great that the win-

dow was badly shattered, although he escaped unhurt. There was no insurance on the window.

A bold but unsuccessful attempt was made to rob George H. Corbett & Co.'s jewelry store, 301 Main St., Worcester, Mass., early on the morning of Dec. 18. Entrance was effected by forcing a window on the Exchange St. side of the building, and the would be burglars got as far as the door leading upstairs. Fortunately, a huge iron bar on the inside of this door stopped further progress. They evidently became frightened and made their escape through a side door.

## Omaha.

James Huteson is spending the holidays in Omaha. He represents the Spencer Optical Mfg. Co.

F. E. Hewitt is representing the Bassett Jewelry Co., New York, and will remain here through the holiday trade.

John Baumer, one of our oldest and largest jewelers, has a great big sign up, saying he is selling out at auction, etc., owing to the depression of the times.

Sol. Bergman has just returned from a quite extensive and very successful business trip through South Dakota and Wyoming. The region around Deadwood and Rapid City is booming as new gold mines have been found there lately.

Van Cott Jewelry Co., corner of 15th and Farnam Sts., in their new store under the Barker Block, have a slightly place of business on one of the most crowded corners in Omaha, and have dressed the large corner window, level with the pavement, in attractive style.

Adolph Meyer, for 30 years one of the firm of Max Meyer & Bros. Co., the oldest jewelers in the city, has taken charge of the musical department in the large department store of Hayden Bros. The musical part of May Meyer's business has been bought by the Haydens.

A shooting affray took place near Afton, Ia., lately, in which three tramps came to grief. They had been loafing about town all day. Towards evening they fell out with each other, when one drew a revolver, and shot the other in the back. They are supposed to be the fellows that robbed Will Gay's jewelry store, at Elliott, of \$1,800 worth of goods. The injured man was taken to Afton, and officers are on the track of the other two.

For the eleventh time, the Pope Mfg. Co. have presented their unique memorandum pad calendar, which has become an almost invaluable adjunct to the desk. The calendar for 1895 is even brighter than its predecessors in appearance, as clever artists have added dainty silhouette and sketch to the usual wise and witty contributions that have heretofore given this calendar its charm.

### Art in Window Decoration.

WHILE it is true that suggestions from a simple source may by gradations become a gigantic achievement, the reverse is likewise true, that we must have recourse to the highest examples to attain simple, artistic effects. In the window of a prominent retail store in Fulton St., Brooklyn, N. Y., during the present holiday season, has been a display of rich cut glass, the like of which has never been seen in any commercial emporium, and we doubt in any international exposition. In the latter circumstance, there have been

The display looks like three solid canopies of glass, made of a certain number of nickel rings, attached with chains and filled with various sized prisms.

In the center, right in front, the observer discerns an handsome epergne which consists of a glass upright surmounted by four cut glass shelves, a flower receptacle being at the top. This epergne was one of the prize pieces at the World's Fair. At each side, right in the center under the glass canopies, are two handsome cut glass candelabra, surrounded by a display of stemware and other pieces. As can be seen, in the back and toward the front are several

upon the white statues, produces a brilliancy which we associate in our minds with a fairy's grotto or cave of diamonds. No engraving could do justice to such a display, but the picture herewith is the finest possible, and it, with the foregoing description, it is hoped, may serve as a lesson to jewelers in window dressing.

The "Calendar of Jewels" presented by Fowler & Wells Co., 27 E. 21st St., New York, is undoubtedly one of the most beautiful ever received in THE CIRCULAR office. On each sheet of the daily memorandum pad is given the jewel of the month, and



A GORGEOUS WINDOW EXHIBIT OF RICH CUT GLASS.

more extensive exhibits, but in artistic arrangement the display referred to has never been excelled.

Of course, it is not in the bounds of a jeweler's capability to duplicate this exhibit, but in the consideration of the display from a window dresser's standpoint, many suggestions may be gleaned by the reader who believes that effective window dressing is an important item in the conduction of a retail business, and who is ambitious to acquire knowledge on the subject.

The display was designed, and its arrangement managed by Emile Katz, who is recognized as a true artist in window dressing, his achievements being famed throughout the country. The idea for this display originated in Mr. Katz' brain while he lay asleep, and veritably its reproduction is a dream of beauty. Immediately upon awaking, he made a pencil sketch of his vision. In his studio he worked up the idea until he obtained the result depicted herewith.

marble statues, displayed as one sees them in the European conservatories. Mr. Katz has tried to make them appear as natural as possible. They are surrounded by artificial plants, moss and ferns. The whole ground is powdered with isinglass, which gives it the effect of being frozen, and under light produces a splendid effect.

Each canopy has about 3,000 prisms. The whole window is backed in white, which, with mirrors, gives an exquisite effect, the display being divided into three sections by the mirrors, which are placed at an obtuse angle, thus reproducing each article and making the display twice as large to the eye. No cut glass but that of L. Straus & Sons' manufacture is in this window, and without doubt the exhibit contains some of the most perfect achievements in cut glass making.

The light from the incandescent bulbs, reflected upon the thousands of prisms reproduced manifold by the mirrors upon the white ground, with its isinglass, and

the sentiment it typifies, while beneath is a quotation from some famous author appropriate to the sentiment. The calendar pad is set on a card 13 x 18 inches, decorated with an exquisitely colored collection of ideal infant heads—a clever imitation of a water color painting.

### WINTER JEWELS.

WE thought in June that earth was offering  
Her richest gems to deck the woodland scene  
With sapphire buds, with glint of ruby wing  
Beneath a leafy roof of emerald green.

Yet gaze again to-day—a topaz sky  
Arches above this Winter paradise;  
Rich pearls of snow o'er earth's fair bosom lie,  
The trees are hung with diamonds of ice.

—Christmas Munsey's.

The New Columbus Watch Co.'s factory, Columbus, O., is on a boom. The company have just put on the market a 21-jeweled movement, 18 size.

# CLASSIFIED INDEX TO ADVERTISEMENTS.

All Advertisements are entitled to one insertion under proper heading. Extra insertions, \$6.00 per annum.  
Extra Headings, \$12.00 per annum.

<b>Art Pottery, Bric-a-brac, Etc.</b>	Page.	<b>Diamond Jewelry.</b>	Page.	<b>Sample Trunks.</b>	Page.
Bing, Ferdinand & Co., 106 Grand St., N. Y. . . . .	40	Leonhardt & Curran, 44½ Maiden Lane, N. Y. . . . .	42	Crouch & Fitzgerald, 161 Broadway, N. Y. . . . .	39
Healey, M. & E., Washington, D. C. . . . .	36	Sauter, L. & Co., 194 Broadway . . . . .	13		
Straus, L. & Sons, 42 to 48 Warren St., N. Y. . . . .	39	Jeanne, Paul, Bradley Bldg., N. Y. . . . .	29	<b>Show Cases.</b>	
				Smith, B. & W. B., 220 W. 29th St., N. Y. . . . .	44
<b>Assayers &amp; Refiners.</b>		<b>Diamond Polishing Mills.</b>			
Baker, Geo. M., Providence, R. I. . . . .	2	Arthur Co., The, 86 John St., New York . . . . .	13	<b>Silver Plated Ware.</b>	
Le Long, L. & Bro., Newark, N. J. . . . .	44			Fairpoint Mfg. Co., New Bedford, Mass. . . . .	5
U. S. Smelting & Refining Works, 25 John St., N. Y. . . . .	44	<b>Fine Stationery.</b>		The Wm. Rogers Mfg. Co., Hartford, Conn. . . . .	40
		Parsons & Greene Co., 18 Murray St., N. Y. . . . .	5	Webster, G. A., Chicago, Ill. . . . .	31
<b>Auctioneers.</b>		<b>Gold and Rolled Plate Jewelry.</b>			
Boyle, Davis & Goodman, 63 5th Ave., N. Y., 611 Pennsylvania Ave., Washington, D. C. . . . .	40	Foster & Bailey, Providence, R. I. . . . .	3	<b>Sterling Silver Novelties.</b>	
Comrie, A. J., 22 John St., N. Y. . . . .	39	Smith, Wm., & Co., 5-7 Maiden Lane, N. Y. . . . .	42	Codding Bros. & Heilborn, North Attleboro Mass. . . . .	39
French, J. H., P. O. Box 2775, N. Y. . . . .	2			Holmes & Edwards Silver Co., Bridgeport, Conn. . . . .	18
H. M. Rich & Co., 21 School St., Boston, Mass. . . . .	39	<b>Gold Jewelry.</b>		Hagan, White & Co., 243 W. 23d St., N. Y. . . . .	2
		Aikin, Lambert & Co., 19 Maiden Lane . . . . .	42-43	Kent & Stanley Co., Providence, R. I. . . . .	10-11
<b>Badges, Medals, Etc.</b>		Carter, Sloan & Co., 15 Maiden Lane, N. Y. . . . .	15	Richardson, Enos. & Co., 23 Maiden Lane . . . . .	39
Stockwell, E. R., 19 John St. N. Y. . . . .	42	Cross & Beguelin, 17 Maiden Lane, N. Y. . . . .	8		
		Schwartz, W. H., & Co., Newark, N. J. . . . .	2	<b>Sterling Silverware.</b>	
<b>Book Marks, Sterling Silver and Gold.</b>		<b>Gold and Silver Novelties.</b>		Fuchs, Ferd. & Bros., 808-810 Greenwich St., N. Y. . . . .	42
Stone Bros., 535 Broadway, N. Y. . . . .	2	Riley, John A., & Sloan Co., Ltd., Broadway and 17th Street . . . . .	5	Towle Mfg. Co., Newburyport, Mass. . . . .	40
		Waite, Thresher Co., Providence R. I. . . . .	20	Wallace, R. & Sons Mfg. Co., 3 Park Place, 6	
<b>Carborundum.</b>				Wood & Hughes, 16 John St., N. Y. . . . .	7
The Carborundum Co., Monongahela, Pa. . . . .	43	<b>Horological Schools.</b>			
<b>Chains.</b>		Chicago Watchmakers' Institute, Chicago, Ill. . . . .	31	<b>Thimbles.</b>	
Kent & Stanley Co., Providence, R. I. . . . .	10-11	Parson's School for Watchmakers, Peoria, Ill. . . . .	31	Ketchum & McDougal, 198 Broadway, N. Y. . . . .	2
		Philadelphia College of Horology, 623 Heed Building, Phila., Pa. . . . .	7		
<b>Clocks, French, English and American.</b>		<b>Jewelry, Silverware and Optical Cases.</b>		<b>Tortoise Shell Goods.</b>	
Jacques, Chas., Clock Co., 22 Cortlandt St., N. Y. . . . .	44	Jackson, S. C., 180 Broadway, N. Y. . . . .	7	Potter, W. K., Providence, R. I. . . . .	5
<b>Cut Glass.</b>		<b>Jobbers, Watches, Diamonds, Etc.</b>		<b>Tool Manufacturers and Dealers.</b>	
Clark, T. B. & Co., 860 Broadway, N. Y. . . . .	2	Allen, Benj. & Co., Chicago, Ills. . . . .	31	Allen, Benj. & Co., Chicago, Ill. . . . .	31
		Aikin-Lambert Jewelry Co., 19 Maiden Lane. 42-43		American Watch Tool Co., Waltham, Mass. . . . .	8
<b>Diamond &amp; Precious Stone Importers.</b>		Brethauer Watch and Jewelry Co., Chicago, Ill. . . . .	33	Moseley & Co., Elgin, Ill. . . . .	31
Disselkoen, John N., 19 E. 16th St., N. Y. . . . .	15	Myers, S. F. & Co., 48 Maiden Lane, N. Y. . . . .	44	Mossberg Wrench Co., Attleboro, Mass. . . . .	37
Falkenau, Oppenheimer & Co., 40 Maiden . . . . .	44			Oliver, W. W., Buffalo, N. Y. . . . .	44
Friedlander, R., L. & M., Ltd. 30 Maiden Lane, N. Y. . . . .	36	<b>Musical Boxes.</b>			
Hedges, Wm. S. & Co., 170 Broadway, N. Y. . . . .	14	Jacot & Son, 39 Union Square, N. Y. . . . .	39	<b>Trunks and Traveling Bags.</b>	
Kahn, L. & M. & Co., 172 Broadway, N. Y. . . . .	44			Crouch & Fitzgerald, 161 Broadway, N. Y. . . . .	39
Kipling, E. E. 182 Broadway, N. Y. . . . .	44	<b>Ophthalmic College.</b>			
Kipling, R. A., Hays Bldg., N. Y. . . . .	14	St. Louis Ophthalmic College, St. Louis, Mo. . . . .	33	<b>Watch Manufacturers.</b>	
Lorsch, Albert & Co., 37 Maiden Lane, N. Y. . . . .	44			Trenton Watch Co., Trenton, N. J. . . . .	9
Nissen Ludwig & Co., 18 John St. . . . .	14	<b>Optical Goods.</b>			
Randel, Baremore & Billings, 29 Maiden Lane . . . . .	15	Geneva Optical Co., Chicago, Ills. . . . .	31	<b>Watch Case Repairers</b>	
Smith, Alfred H. & Co., 182 Broadway, N. Y. . . . .	14	Queen & Co., Philadelphia, Pa. . . . .	44	The Planchamp & Becker Co., Chicago, Ill. . . . .	31
Tannenbaum, L., & Co., cor. Maiden Lane and Nassau St., N. Y. . . . .	23			Henry, Peter, Cincinnati, O. . . . .	31
		<b>Pens, Pencils, etc.,</b>			
<b>Diamond Cutters.</b>		Aikin, Lambert & Co., 19 Maiden Lane, N. Y. 42-43		<b>Watch Importers.</b>	
Arnstein Bros., 45 John St., N. Y. . . . .	38			Hyde's, J. E., Sons, 22 Maiden Lane, N. Y. . . . .	42
Fox Bros. & Co., 68 W. 4th St., Cincinnati, O. . . . .	31	<b>Ring Makers.</b>		Racine, Jules, 180 Broadway, New York. . . . .	43
Oppenheimer Bros. & Veith, 35 Maiden Lane, N. Y. . . . .	7	Bowden, J. B. & Co., 192 Broadway, N. Y. . . . .	16		
				<b>Watch Keys.</b>	
		<b>Safes.</b>		Clark, A. N., Plainville, Conn. . . . .	44
		Mosler, Bahmann & Co., 518 B'way, N. Y. . . . .	39		

## Special Notices.

Rates 75c. per insertion for notices not exceeding 3 lines (25 words); additional words 2 cents each. If answers are to be forwarded, postage stamps must be enclosed. Two insertions, 15 per cent. off; three insertions, 20 per cent. off; four insertions or more, 25 per cent. off. Payable strictly in advance. Display cards on this page will be charged at \$2.00 per inch for first insertion, subject to same discount as above for subsequent insertions.

Under the heading of **Situations Wanted** on this page advertisements will be inserted for **One Cent a Word**. This offer refers to **Situations Wanted only**. Payable strictly in advance. If answers are to be forwarded, postage must be enclosed.

## Situations Wanted.

*Notices under this heading ONLY are charged at one cent a word, payable strictly in advance. If answer are to be forwarded, postage must be enclosed.*

**BOOKKEEPER**, absolutely reliable and competent to take charge of office, credits and collections, desires to make a change; for number of years in similar position in watch and diamond line; excellent references. Address Amiable, 170. Care **JEWELERS' CIRCULAR**.

**POSITION** desired by young man of good address and ability, where 12 years' business experience and acquaintance with New England, Middle States, and southern jewelry trade will enable him to advance; highest references. W. A. L. S., P. O. Box 1276, New York.

**SALESMAN**.—A first-class man, with unquestionable references as to ability, character, &c., direct from one of the largest houses in N. Y. city, desires an engagement to travel in New England, New York city and near-by towns. Would like line of fine gold jewelry or any manufacturer's line. H. J., **JEWELERS' CIRCULAR**.

**WANTED**, a position as salesman, after Jan. 1st, in a wholesale or retail jewelry business, by one who is at present engaged with one of the leading jewelry firms in this city. Best of references given. Address A. A. X., care **JEWELERS' CIRCULAR**.

**WANTED**, by a practical jeweler. Experienced foreman and designer, especially diamond work, wishes a position by Jan. 1st. Address A. B., care **JEWELERS' CIRCULAR**.

**SITUATION** as traveling salesman to call on the retail jewelry trade; 9 years experience as watchmaker and salesman. Best references. Address 24, care **JEWELERS' CIRCULAR**.

**TO MANUFACTURERS**.—Situation wanted as traveler; either silver goods or gold jewelry. Ten years' experience in retail store. References. Address B. D. S., care **JEWELERS' CIRCULAR**.

**WANTED**, to finish trade, 3 years' experience. Best of references. Address T., care of John Burgess, Bloomfield, Iowa.

**WANTED**, situation by young man as engraver and assistant watchmaker; good in general about a jewelry store. Sober and industrious. Address M. A. C., care of **JEWELERS' CIRCULAR**.

**WANT** a salesman, jeweler, watchmaker or optician? If so, write F. E. Moore, Box 244, Rochester, N. Y.

**BY** a live young man; first class watchmaker, jeweler and salesman; some experience on electric clocks. Address J. D. Hathaway, Elizabeth City, N. C.

**A WATCHMAKER'S** assistant wants position; can do nearly all ordinary run of plain work; French clocks, etc.; coffin plate engraving; is a salesman and a good one; is an all-the-year-round kind of a man, year after year; wants to earn \$10 per week. Address Assistant, 42 Austin St., Bridgeport, Conn.

**POSITION**. A watchmaker, expert engraver; elegant bench and tools; quarter century experience in city trade's association; married; good address; reliable; state wages paid. Address "Eastern," care Carrier No. 4, Newton, Kans.

**SITUATION WANTED**—By competent watchmaker, jeweler and engraver; wages moderate. Address Parker, Lock Box 401, Madison, Ohio.

**A TRAVELING** salesman of nine years' experience will be open for an engagement Jan. 1. Acquainted with the trade in New England, New York State, Pennsylvania and the south; A1 references. Address B. M., Box 1276, New York.

**HAVING** an extended acquaintance with both the wholesale and retail trade throughout the west, I should like to form a connection with some manufacturing jeweler as traveling salesman; fine goods preferred; salary moderate. Address Traveler, care **JEWELERS' CIRCULAR**.

**WANTED**—A position by a married man; age 35; has had seven years' experience in retail, eight years traveling; A1 salesman; prefers New York City or near by trade; reference guaranteed. A., care **JEWELERS' CIRCULAR**.

**WANTED**—A position as representative in New York City and neighborhood trade; manufacturing jeweler preferred; best reference; ten years' experience; salary or commission. H., care **JEWELERS' CIRCULAR**.

**A MAN** 37, a practical jeweler with most excellent personality, conversational ability and pleasing address would like a chance on the road; believes he could build up, secure, and hold a good trade; has very moderate ideas of salary, but for a good house very effective work could be done; time and patience are the necessary qualities and they will bear much fruit; I estimate being considered a good man after I have had time to grow into the place. Will some good house give me a chance? Address Salesman, 42 Austin St., Bridgeport, Conn.

**SITUATION** wanted by watchmaker with local jobbing house; 20 years' experience; A1 references; buys \$5-6,000 annually for his trade. S. L., care **JEWELERS' CIRCULAR**.

## Help Wanted.

**A TRAVELING** salesman to handle a first-class line of jewelry on commission in New York State, Pennsylvania, Ohio, or any one or two of the three, calling on the legitimate jewelry trade only in connection with his present line. Address T. 74, care **JEWELERS' CIRCULAR**.

**WANTED**, good engraver, who can assist watchmaker when not busy engraving, for leading store in the southwest. Address, giving age and salary wanted, S. Charles, P. O., Memphis, Tenn.

**WANTED**—A TRAVELER WELL ACQUAINTED WITH NEW ENGLAND JEWELRY TRADE. ONE WHO HAS HANDLED SILVER PLATED WARE. ADDRESS M., CARE **JEWELERS' CIRCULAR**.

**A TRAVELING** salesman wanted who commands first class trade in American watches and diamonds; New York State, Pennsylvania, and near by southern States. Address Diamonds, care **JEWELERS' CIRCULAR**.

## For Sale.

**FOR SALE**—Tools, fixtures and machinery of a manufacturing jeweler; can be seen in working order. Address King & Co., 355 Mulberry St., Newark, N. J.

**A RARE** opportunity for the purchase of a first-class jewelry and optical business in Asbury Park, N. J., the world-famed seaside resort; the long-established business of H. Schmidt, deceased, at No. 639 Cookman Ave., including stock, safe, fixtures, tools and materials is offered for sale; the location possesses unsurpassed advantages for a splendid investment. For full particulars address S. A. Patterson, Administrator, care **JEWELERS' CIRCULAR**.

**FOR SALE**.—New Weiland optometer, new ophthalmoscope placido disc, telegraph key and sounder, astronomical telescope, fine violin, marine chronometer and watch adjuster's oven. All in good working order. Write for particulars and prices, S. Richards, South Paris, Maine.

## Miscellaneous.

**I BUY JEWELRY STOCKS**—Manufacturers, jobbers and retailers desiring to dispose of surplus or entire stocks of diamonds, watches and jewelry, can find quick cash buyer by addressing Oscar Langer, 176 Broadway, Room 58½, or 223 E. 71st St., New York.

**GIVEN** on memorandum about Sept. 1st five Siam rubies about 6½ karats. Would party kindly report on same? Address Army, care **JEWELERS' CIRCULAR**.

## Business Opportunities.

**PHOTO-ENGRAVING**—An exceptional opportunity in a long, well established and favorably known plant, fully equipped and at work. Expert manager will remain if desired and retain half interest. Owner must sell whole or in part promptly for valid reasons and will do so at a great sacrifice. To an active out-door worker this offers great advantages. Address V. S. M., care **JEWELERS' CIRCULAR**.

## WHEEL CUTTING.

We make a specialty of Wheel Cutting, Demagnetizing and Watch Repairing for the trade. Complete plant. Send for price list.  
**THE WINSLOW & PENNEY CO.**  
608 Masonic Temple, - CHICAGO.

## TO OPTICIANS.

I am the originator of several optical illusion cards which are trade winners. Only sold to one optician or jeweler in each town or city. Prices to the trade on application. First come first served.

**WM. M. UPDEGRAVE,**  
242 Main Street, Johnstown, Pa.

## FOR SALE.

**Machinery, Tools, Fixtures, Merchandise, Material, Book Accounts, receivable, Bills, receivable, and Land Contract** for the premises now occupied by the **UNITED STATES OPTICAL CO.**, Detroit, Mich., Address Oscar B. Marx, Secretary.

To insure Publication of Advertisement in current week, copy should be received not later than Monday Night.

## OLDEST PUBLICATION

Of all the Jewelry Journals.

**Jewelers' Circular Publishing Co.,**

189 BROADWAY, NEW YORK.

ESTABLISHED 25 YEARS.

# Paul : Jeanne's : Revolving : Hairpin.

THE LATEST NOVELTY.

220 Fourth Ave., cor. 18th St.,

NEW YORK.

THE STAR OF EMPIRE WESTWARD TAKES ITS WAY

# WESTERN SUPPLEMENT of THE JEWELERS' CIRCULAR

Chicago Office: Room 517, Inter-Ocean Building.

VOL. XXIX.

CHICAGO, WEDNESDAY, DEC. 26, 1894.

NO. 22.

## Chicago Notes.

### TRADE CONDITIONS.

The great difficulty with plated silver houses is in getting goods as rapidly as orders are being received.

Collections show a falling off the past few days, due probably to the sales department requiring the undivided attention of the retail jeweler.

Buyers were few in number and in the crush of business no names could be secured. Only those in and immediately adjoining Chicago are present.

The jobbing houses were great, throbbing hives of industry the past week, and there were no drones. The volume of goods distributed in the 18 and 20 hours of each day that were devoted to business will never be known, but the power of the distributors was sorely tried, and the volume was enormous. It was rush, rush everywhere, and little could be learned by correspondents. The remark was universal: "Too busy to talk; don't know where we're at!"

E. C. Fitch, president of the American Waltham Watch Co., spent the past week at the Chicago office.

E. A. Haseltine & Son, Kokomo, Ind., have opened a new store in that city, giving them two locations on the main street.

F. H. Shearer, Bay City, Mich., is manufacturing a line of fine hall clock cases for which the orders are numerous.

Burglars broke into William Dart's Jewelry store, 321 West Madison St. 5 o'clock Friday morning and secured \$350 worth of goods.

A. H. Simon, St. Paul, Minn., is said to have sold \$30,000 worth of goods in his four weeks' auction sale. Burroughs, of this city, was the auctioneer.

Mr. Schauweker left Saturday for New York, where Mrs. Schauweker (née Glatz) is visiting her parents, and will spend the holidays in the east.

Herman Jewell & Co., of Chicago, have incorporated to do a jewelry business;

capital stock, \$2,000; the incorporators are: William H. Slack, C. L. Lonergan, L. C. Hurley.

B. F. Ashelman, Ada, Minn., has sold out to Fred. Lauctot, and the purchase money will be applied to the payment of the former's liabilities. The consideration for stock and tools was \$1,800.

Zi Riley, Champaign, Ill., has finely fitted up his store. The removal of a partition gives increased space and an increased latitude for display that Mr. Riley has not been slow to take advantage of.

L. A. Antoine, 212 North Ave., has as a window display a Ferris wheel in brass, an almost exact fac-simile in miniature of the original. The wheel is for display purposes and revolves by electric motor.

Frank Strohm, 2821 Archer Ave., was afflicted with paralysis of the lower limbs the past week and is unable to personally attend to business. The illness is considered curable and his many friends hope for his rapid recovery.

C. T. Wittstein & Co., who deal largely with the outlying city trade on West, North, and South Sides, says the retailers there have had a much better holiday trade than they anticipated, and that present demands on his stock are unusual.

Simpson, Hall, Miller & Co. report trade for the past six months considerably in advance of the corresponding period of last year, and the past week they were hardly able to keep up with the flood of orders. The demand for the Yale pattern in fancy pieces has been simply overwhelming.

"Everybody in my district seems to be having very good trade and the majority claim their year will wind up 20 per cent. better than last year. My own trade has been better than for eight years past." Thus spoke G. W. Payson, just returned from Michigan and Indiana in the interests of the Seth Thomas Clock Co.

The Gorham Mfg. Co. never before were so busy as they have been the past week and never before were so short of goods. The force have been working nights the entire

month. The Luxembourg pattern has exceeded all previous sales and the Imperial Chrysanthemum has exceeded it in sales and is the most successful pattern the firm have ever placed on the market.

George Dilger, 419 W. Chicago Ave., who some time since was assaulted by highwaymen in his store, was offered \$500 cash to forego prosecution of the criminals, but indignantly refused to be a party to the deal. Not only that, but Mr. Dilger is taking time from his business in these busy days to see that the case against his assailants is pushed.

A called meeting of the banquet committee of the Chicago Jewelers' Association was held Thursday, 4 to 5 o'clock p. m. Details as to speakers and general outline of the banquet were discussed and work mapped out but no final decision was arrived at. As members of the committee will be absent from the city for a couple of weeks no definite action will be taken until their return. The banquet will be held at Kinsley's, Jan. 24.

James K. Wiggins, just returned from Guatemala, brings with him some remarkable pieces of pottery, the handiwork of descendants of some of the old Aztec tribes. Most of the collection is of statuary, reminding one in general conformation of the Rogers' groups, but more lifelike. A matador on a bull, in the brilliant southern colorings, is a genuine art piece. Mr. Wiggins picked up some 60 pieces in his travels through the country.

The Wisconsin Central R. R. report of watch inspection just completed by J. W. Forsinger, general inspector of railway watches, shows none rejected out of 246 examined. Of the 213 compared with standard time the average day's run was 26, with a daily average variation of but six-tenths of a second. The inspectors on the Wisconsin Central are: A. C. Nichol, of Waukesha, Wis.; Reton Bros. & Co., Stevens Point, Wis.; C. B. Morse, Chippewa Falls, Wis.; A. L. Haman, St. Paul, Minn.; E. J. Born, Ashland, Wis.; H. H. Sheldon, Bessemer, Mich.; George Henry Elvis, Medford, Wis.

# LOOK AT THESE PRICES!

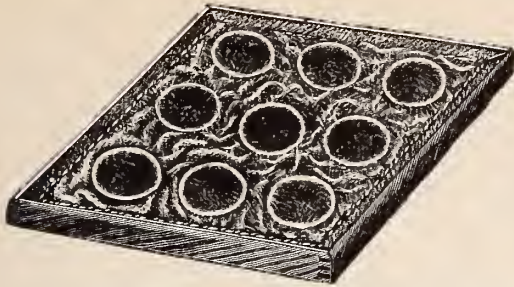

Show Case Trays with Solid Walnut Frames lined with Fine Red Silk Plush, with Old Gold Border, and made to stack one on top of the other. Size, 11 3/4 x 11 3/4.

For Gents' Watches, each, . . . . . \$1.25  
For Ladies' Watches, each, . . . . . \$1.25  
For Rings, each . \$1.25. For Chains, each, . \$1.25  
For Charms, ea., \$1.25, for Card Jewelry, plain, ea., 80c.

Subject to the usual discount for cash.

## CHRISTMAS IS COMING.

Make your Stock Attractive and Fresh. It does not cost much and will add largely to your SALES.

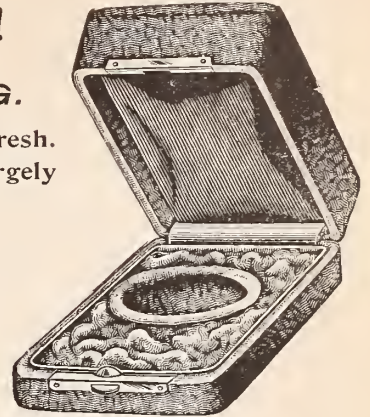

FINE PLUSH BOXES.

## BENJ. ALLEN & Co.,

141 & 143 State St.,

CHICAGO, ILL.

WATCHES, CLOCKS,  
DIAMONDS,  
SILVERWARE  
and JEWELRY.

For Gents' Watches, per dozen, \$3.00  
For Rings, per dozen, \$2.00  
For Six Tea Spoons, per dozen, \$9.00  
For Child's Set, per dozen, \$9.00  
For Sugar Shell, per dozen, \$9.00  
For Ladies' Watches, per dozen, \$3.00  
For Ear Drops, per dozen, \$3.50  
For Six Table Spoons, per dozen, \$15.00  
For Six Coffee Spoons, per doz., \$15.00  
For Butter Knife, per dozen, \$9.00

Subject to the usual discount for cash.

DON'T FORGET THE JEWELERS' CIRCULAR PUBLISHING CO.'S BOOK LIST when in want of any technical book in the Jewelry or Kindred Trades.



## GENEVA OPTICAL CO., CHICAGO.

CATALOGUES.

- PART 1—General Catalogue of Optical Goods.
- " 2—Microscopes and Accessories.
- " 3—Photographic Cameras, Stocks and Supplies.
- " 4—Thermometers, Barometers and Meteorological Instruments.

### PRESCRIPTION WORK

Made with Promptness and Accuracy.

### OCULISTS' or OPTICIANS' OUTFITS.

Trial Cases.  
Ophthalmoscopes.  
Lens Measures.

CORRESPONDENCE SOLICITED.

### THE PLANCHAMP & BECKER CO

Makers and Repairers of

### WATCH CASES.

Gold and Silver Plating —  
— of Watch Cases a Specialty  
UNEXCELLED FACILITIES.

63 and 65 East Washington St., Chicago.

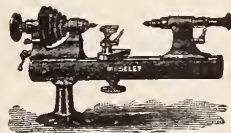

One of the best of the very best.

QUALITY IS THE STANDARD OF VALUE FOR WHICH WE COMPETE

### "THE MOSELEY."

"A Bread Winner" for the watchmaker. We furnish you good lathes and chucks, while the other fellow furnishes the wind.

MOSELEY & CO., Elgin, Ill.



No. 2 Moseley Wire Chuck has length, strength, accuracy.

MORE ADVANTAGES—LESS COST.



## CHICAGO ROCKFORD Watchmakers' Institute

211-20 WALNUT ST., ROCKFORD, ILL.

Write for New Terms. \_\_\_\_\_ :

G. D. PARSONS, Principal

EST. 1870.



DR. PETER HENRY  
SPECIALIST IN

### Watch Case Diseases

Key Winders changed to Stem Winders

Hunting Case changed to O.s

English Case changed to fit American movements.

Can be cured at

53  
LONGWORTH ST.  
Cincinnati, Ohio.

### PARSONS : SCHOOL

—FOR—  
WATCHMAKERS,

PEORIA, - - - ILL.

Send for Circular and Terms.

PARSONS & CO.

### G.A.WEBSTER

42 & 44 Madison St., Chicago, Ill.

Manufacturer,

AND WESTERN AGENT FOR

E. G. WEBSTER & SON, of Brooklyn, N. Y.

A. F. TOWLE & SON CO., of Greenfield, Mass.

DIAMOND CUTTERS and POLISHERS looking for desirable and permanent positions should apply direct to

# FOX BROS. & CO.,

68 and 70 West 4th Street,

CINCINNATI, OHIO.

### Cincinnati.

Isa Schroder is still on the road, having a harvest in trade.

E. & J. Swigart have had unprecedented sale in boxes and trays.

Bene, Lindenberg & Co. worked until midnight every night last week.

Rudolph Jacobs has had a relapse and will not get out again until after the holidays.

Sigmund Strauss, of Frohman, Wise & Newman, has returned from a very successful trip. He was called home by the press of trade.

Oskamp, Nolting & Co. were almost swamped with orders the past two weeks. "Never have seen anything like it," Mr. Nolting said.

The rush of trade the past week has been a surprise and delight to the jewelers. There has been no auction sale of note this season, and the jewelers have been correspondingly happy.

### Detroit.

J. A. Jackson, Kalkaska, Mich., occupies new quarters in the store of Goodrich & Co.

Aaron Segan has given a chattel mortgage on his stock of jewelry and watches, at 103 Atwater St., for \$450, to David Segan.

Rudolph Kern has given a chattel mortgage for \$700 subject to a previous mortgage of \$556, to William Dyer as trustee on the stock of jewelry at 171 Griswold St.

Stone & Carpenter, formerly Stone & Bell, Ypsilanti, Mich., have secured the services of Louis M. Beck, Peru, Ind., as head watchmaker. Mr. Bell has gone into business in Jackson, Mich.

Black & Connolly, 145 Woodward Ave., have dissolved partnership by mutual consent, Mr. Connolly retiring. The business will be continued under the old firm name. Mr. Connolly will take a short eastern trip before making any calculations as to his future business. It is said that he will start a store in this city.

C. M. Heck, Clio, Mich., recently accepted the agency for J. E. C. Haack, jeweler, and moved to Saginaw where he went into business. It did not pan out well and he packed his stock and placed the more valuable portion of it under his bed. Burglars broke in and Mr. Heck claims they stole everything in sight. No clue.

Readers of THE CIRCULAR will remember the item stating that burglars broke into Mosher's jewelry store, at Holly, and stole a quantity of goods. John Donovan and James Walker were caught with the booty in their possession. Last week Judge Moore, of that place, sentenced them to three years' imprisonment in Jackson prison.

The jewelry stores of this city were alive with customers last week, and on one or two days the biggest sales for several previous seasons took place. The weather has

been mild and soft, which has brought out the shoppers in crowds. The jobbers have also felt the stimulating movement, and for the first time in many months were compelled to work nights to fill orders. Among the Michigan country jewelers who purchased goods here last week were: J. E. Haep, Montpelier, O.; L. A. Steele, Linden; C. E. Montford, Utica; Mr. Moores, Holly; and Charley Morton, Brooklyn.

### Rockford.

Niles Barnhill, an engraver, has accepted a position with D. F. Sullivan.

The Rockford Silver Plate Co. have shut down until Jan. 7th, for a holiday vacation.

A watchmakers' guild has been organized here with the following officers: President, J. D. Perry; vice president, C. H. Blume; secretary, David H. Goldsmith; treasurer, T. A. Wandrey; librarian, C. H. Hulbert; editor, V. A. Holbrooke.

Edward Carpenter, a practical jeweler and L. R. Shumway, a prominent young business man have formed a partnership and will embark in the jewelry business. They have leased the building at the corner of E. State and 1st Sts., one of the best locations in the city, and intend to fit up a very handsome store. They are now purchasing stock and furnishings.

### Indianapolis.

Wm. Haushalter, Anderson, Ind., was in the city buying goods last week.

H. Emory Pease, a jewelry manufacturer of Connecticut, spent several days in this city last week.

The Model Clothing Co. announce that they have placed on sale the bankrupt stock of the jewelry firm of Burt & Hurlbut Co., Detroit.

John Drew, who broke H. D. Burgheim's jewelry store window, in daylight and attempted robbery, has been sentenced to three years' imprisonment.

A very fine bed of aluminium clay has been found near Rushville, Ind., and experts pronounce the quality of the best. A cash offer has been made to the owner with a view to develop the find.

### The Death of George Menger Causes Much Excitement.

BALTIMORE, Md., Dec. 19.—George Menger, aged 40 years, member of the jewelry firm of Menger Bros. & Wagner, 13 W. Lexington St., died after a short illness Monday at his home, 221 N. Gilmor St. He had been suffering from typhoid fever, it is said.

A report was circulated about town that he had dropped dead in his store, and when the store was closed Monday a large crowd assembled outside, and a detective and several policemen were required to clear the sidewalk. Much excitement resulted. The firm have been in existence about a year.

### Points of Law.

#### LIABILITY FOR SALE IN FRAUD OF CREDITORS.

One who buys goods knowing that the sale is in fraud of creditors, and mingles them with his own, does not by so doing forfeit his entire stock to the creditors of the seller, but if he refuses to point out the goods the creditors can levy on enough of the mingled goods to equal those of the seller.

*B. C. Evans Co. v. Reeves (Court of Civil Appeals of Texas.)*

#### LIABILITY FOR LOSS OF JEWELRY CHECKED AS BAGGAGE.

Where the bond required by a railroad company as a condition of the issuance by it of a permit to have jewelry sample cases checked as baggage is returned by the company to the person applying for such permit to be acknowledged by him, without issuing the permit, there is no acceptance by it of the bond. Wherein an action against a railroad company for the value of a jewelry sample case, checked as baggage, in violation of a rule of the company, it appears that the shipper wrote to the company to send him the usual permit for one of their traveling salesmen to check baggage, a finding that he was ignorant of such rule is erroneous. A person who, by the exercise of ordinary care, could have known that the checking of jewelry sample cases by station agents was prohibited by a rule of the company, cannot recover the value of such case if lost.

*Weber Co. v. Chicago, St. P. M. & O. Ry. Co. (Supreme Court of Iowa.)*

#### WHEN TITLE TO PLEDGED GOODS REMAINS IN PLEDGEE.

The use by merchants of banker's credits is an important element of the conduct of commerce, and is calculated to present, from time to time, questions of no little nicety. But arrangements and agreements have been construed so recently and so fully by the court of appeals that we have rules for our guidance which can be safely followed. These cases are uniform in holding that the title remains in the banker until the merchant shall have fulfilled the engagement, under which he procured the credit of the banker for the purchase of the goods; and that, except as to bona fide purchasers from the merchant, not warned of the banker's right or title, possession by the merchant remains that of, or subject to the rights of the banker. The situation is treated as a species of conditional sale, not consummated until the banker is made good for the use of his credit, and equities are administered accordingly.

*Dennistown v. Bar. (Supreme Court, Special Term, New York County.)*

Max Rudert, Duquesne, Pa., will remove to McKeesport, Pa., the first of the new year.



### San Francisco.

Among the retailers sales have all been small ones, but the number of purchasers have increased. The trade is in general confident that with the new year business will be good again as in former years.

Robert Bonestell, of the California Jewelry Co., is the happy father of a baby girl.

Harry Nordman has returned from a successful trip through northern California and Oregon for the Standard Optical Co.

Among the interior jewelers in town buying goods, last week, were: Harry Frutig, Gilroy; J. F. Lowe, Hollister; H. C. Warner, Fresno; G. A. Thiel, Redwood; H. L. Amstutz, Napa; J. W. Moomaw, Portersville; Chas. Noack, Sacramento; C. Rappe, Watsonville.

The Standard Optical Co. continue to make extensive improvements in their establishment. They are now negotiating with Dr. Julius King, Cleveland, O., to come to the coast and give a series of lectures on optics. This is done to qualify their patrons in the handling of their goods and treating patients at their respective stores throughout the interior.

### Pacific Coast Notes.

A. C. Mayers, Watsonville, Cal., has removed into a new store.

A. S. Montgomery, formerly of Auburn, Cal., has located in Birmingham, Ala.

Anderson Bros. have sold their business in Martinez, Cal., to Reed McCraney and will locate in Auburn.

A. P. Hall has sold his jewelry store in Hanford, Cal., and will return to Tulare, where he will continue his business.

Owing to the continued illness of H. W. Bernheim, Napa, Cal., his father, J. W. Bernheim and H. Schwarz have taken charge of his business.

Geo. H. Doerr, jeweler, Spokane, Wash., met with a serious accident, Dec. 11th. He was working near an alcohol lamp when it exploded burning his hair and face frightfully. The extent of his injuries has not yet been ascertained.

The capital stock of the Seattle Watch Co., Seattle, Wash., whose incorporation was announced in THE CIRCULAR last week, is \$1,000, and the business the company are to prosecute is "the manufacturing and dealing in clocks, watches, silverware," etc.

The Simon Rumpf case in Seattle, Wash., was again brought to notice in the Superior Court, Dec. 10, by the filing of affidavits by George S. List and Andrew Woods to the effect that certain gold rings valued at \$336, seized by the sheriff Dec. 4, while in the possession of the Great Northern Express Co., were the property of Wildprett & Saacke, Providence, R. I.

Jewelers in several California cities are seeking protection for their holiday trade by petitioning the councils to pass pro-

hibitory license ordinances that will have the effect of stopping the fake jewelry auctioneers. At Sacramento the license has been placed at \$15 per day, payable in advance, under \$500 penalty. The same rate is petitioned for by the Riverside dealers, while those of Los Angeles and Santa Ana think that \$25 per day is not too much. It is also recommended that no license be issued for less than 30 days.

### Kansas City.

D. P. Ward, salesman for Woodstock, Barger & Hoefer, has just returned from an extended western trip, and will remain in the city until the first of the year. Mr. Hoefer has also returned for the holidays.

Frank R. Cross, of the New Columbus Watch Co., Columbus, O., was in town last week to attend the annual meeting of the Mystic Shrine. Mr. Cross belongs to Alladin Temple in Columbus. B. H. Beatte, jeweler, Sterling, Kan., was also here. He belongs to Isis Temple.

Country trade was exceedingly good the past week. The following buyers were in town: W. H. Myer, Lossing, Mo.; L. J. Huey, Excelsior Springs, Mo.; H. Kollsbad, Pleasant Hill, Mo.; J. H. Sherman, Paolo, Kan.; C. E. Wharton, Topeka, Kan.; A. F. Zimmerman, Warrensburg, Mo.; B. H. Barthe, Sterling, Kan.; L. Megede, Richmond, Mo.; A. Z. Megede, Norborne, Mo.

One of the most interesting window displays seen this season was that by the Jacard Watch & Jewelry Co. last week, on the day the Shriners had their annual meeting. In the foreground were several Egyptian images on camels, crossing the burning sands of the desert, and in the background could be seen the weary travelers as they reached the oasis, where "zimzim" was dispensed. Both sides of the window were tastefully decorated with High Priest's and Eminent Commander's jewels. Among the Kansas City jewelers who attended the Shriners' meeting were Eugene G. E. Jacard, Robert Gilbert, Harry Carswell and R. N. Mercer.

### Elmira, N. Y.

John Bally & Son announce that they intend to remodel their present store after the holidays.

Socrates Ayres has completed his 50th year in business here, and is receiving the hearty congratulations of his friends.

Robert L. Whitson, a jewelry dealer, is confined in the Chemung County jail on a body execution. He will stay there until two judgments against him are paid or he secures bonds.

### A Bucketful of Diamonds.

MANY stories are told of Cecil Rhodes, but the following regarding a smart transaction he had some years ago with his financial colleague, Mr. Barnato, another of the diamond magnates of Kimberley, and as well and widely known throughout South Africa as Mr. Cecil himself, is especially interesting. Mr. Rhodes, as chairman of DeBeers Co., has often had the disposition of the company's output of diamonds within his control, while Mr. Barnato, on behalf of his firm, Barnato Bros., has been one of the heaviest purchasers of the glittering vanities. He had made Mr. Rhodes an offer for the whole of DeBeers stock, which practically meant all the diamonds in the market at the time. Mr. Rhodes replied that he would let him have them on condition that they should pour the whole lot, 220,000 karats, into a bucket and thus be able to gaze upon what no human eye had ever previously seen, viz.: a bucketful of diamonds.

"Done," replied Mr. Barnato, in his characteristic fashion, "I'll take them."

So the bargain was completed, and they poured the mass of glittering gems into a bucket.

It is said that they gazed long and attentively at the unique sight, and after the bucket had been photographed, the goods—diamonds are termed "goods" in the trade at Kimberley—were duly delivered to the purchasers. Then the acuteness of Mr. Rhodes showed resplendently. Sorting and classifying uncut diamonds is a tedious, responsible and protracted process, and in this bucketful there were 160 different sorts or sizes. Barnato Bros. were six weeks in re-sorting, and the gems were necessarily kept off the market all that period. And, of course, Mr. Rhodes had the market to himself all the while, and scored one over the deal.

## —17 Jewel Dueber-Hampden Watches—

ARE THE MOST RELIABLE WATCHES MADE.

A FULL LINE OF DUEBER CASES AND HAMPDEN MOVEMENT.

Write for New Price List.

**Brethauer Watch and Jewelry Co.,** Special Agents,  
71 WASHINGTON ST., CHICAGO, ILLS.

## The St. Louis Ophthalmic College and Hospital

A SCHOOL OF THEORETICAL AND APPLIED OPHTHALMIC OPTICS.

1655 SOUTH JEFFERSON AVENUE,

N. W. Corner Lafayette Avenue, ST. LOUIS, MO.

For the Announcement and further information, address Ignatz Mayer, M. D., President.



# THE VALUE OF THE JEWELERS' CIRCULAR,

..... AS EXPRESSED IN .....

## UNSOLICITED TESTIMONIALS.

The following unsolicited expressions of opinion were recently received:

### REGARDING THE JEWELERS' CIRCULAR.

Enclosed find \$2 for another year's subscription to your valuable journal. Long live THE JEWELERS' CIRCULAR is the wish of  
CHAS. TUCKER, Del Norte, Cal.

As soon as our subscription is out, we shall renew it. We shall take THE CIRCULAR as long as we are in business.

MARKS & KRANK, Schenectady, N. Y.

I am *well pleased* with THE CIRCULAR and no man in this business can afford to be without it.

H. A. ANSTEAD, Massena, N. Y.

I would feel lost without THE CIRCULAR for it is the Heart of the jewelry trade.

S. E. WILLIAMS, Gloversville, N. Y.

THE CIRCULAR has been visiting me monthly and weekly for the past 18 years.

H. H. ROBINSON, Presque Isle, Que.

It is *the* live jewelers' paper and keeps us in touch with the trade throughout the continent. We want it if only for the advertisements.

BRITTON BROS., Lindsay, Ontario.

We think it pays to keep posted. We read our CIRCULAR and find it to be one of our very useful helps.

BROWN, HIXON & Co., Lockport, N. Y.

It is the *Best* paper on the market and one cannot be without it.

R. J. TRUMBULL, What Cheer, Ia.

THE CIRCULAR has been the means of saving me considerable money in the last three years in buying goods from jewelers who advertise in it.

H. M. TURNEY, Goodland, Kan.

I always find THE CIRCULAR very interesting, and find many points of information in the same which have often proved to be quite valuable to me.

A. E. HAHN, Westerly, R. I.

Think each article you publish about "Window Decoration" worth the full price of your subscription, and trust you will have more of them this year.

GEO. E. FEAGANS,

Joliet, Ill.

### REGARDING "WORKSHOP NOTES."

Workshop Notes received and am well pleased with it. I think every watchmaker should have one, for there are points that could improve their knowledge. I recommend very highly.

S. E. WILLIAMS,  
Gloversville, N. Y.

I received my copy of Workshop Notes last night and am very much pleased with same.

H. W. SELTS, Clay Center, Kan.

Your Workshop Notes is a valuable book of reference and all watch makers and jewelers should have a copy.

FRANK P. MCKENNEY, Portland, Me.

I received my copy of Workshop Notes and I am very much pleased with it.

E. H. HAYWARD, Ballston, N. Y.

More than pleased with the Workshop Notes.

C. W. BLAKE, Baltimore, Md.

Will say that I think Workshop Notes will be very handy and helpful to any one as a watch maker and jeweler,

D. L. CLEELAND, Butler, Pa.

I also wish to add my testimony to the value of "Workshop Notes." It is a book brim full of facts which cannot fail to be of great value to the workman. I have tested its value for a year past and I find it a valuable book.

J. H. HARMON, Bolivar, N. Y.

### REGARDING THE CIRCULAR'S SPECIAL NOTICE PAGE.

We are very much indebted to THE JEWELERS' CIRCULAR through whose columns we secured our very competent watchmaker and optician now in our employ.

C. H. ANKENY Co., Lafayette, Ind.

We are very well satisfied with the results of our ad. and think we can be suited.

JAS. D. LEYS,

Butte, Mon.

Must say we got excellent returns from the little ad. showing plainly that your medium is read far and wide.

S. JACOBS & Co.,

Minneapolis, Minn.

THE JEWELERS' CIRCULAR IS A COMPENDIUM OF NEWS, TECHNICAL INSTRUCTION AND VALUABLE SUGGESTIONS FOR THE CONDUCTING OF A JEWELRY BUSINESS.

## MATTERS IN JEWELRY STOREKEEPING.

That this department shall prove mutually beneficial to our readers, it is desirable that the members of the trade generally communicate with THE CIRCULAR regarding any advantageous device or plan that they are utilizing in the conduction of their business.

### Optical Illusions as Advertising Devices.

WE have had occasion to call attention under this department to the optical illusions devised by Wm. M. Updegrave, optician, Johnstown, Pa. We are in receipt of two of these devices which, we understand, are sold by Mr. Updegrave to one optician or jeweler in each town or city. One of these devices consists of a pile of blocks printed in red, blue and purple. By looking at a star in the center, one will see three blocks on the bottom row, two on the next, and one on top. Continuing to look, one notes a sudden change, namely: two on top, three in the middle and two on the bottom row.

The other device consists of a profile of a man's head in red ink, the eye being a white spot. The directions require one to look at the head in the eye for 30 seconds, then to turn the card and look at a red spot on the reverse side for a few seconds, and the face appears in blue instead of red—a pale blue mayhap, but the illusion is quite positive. Such cards as these are most effective forms of advertising.

### Marking Cleaned Watches.

A "SUNBEAM" in the New York *Sun* contains a good hint to jewelers. The item is as follows: Fine watches are commonly kept in order by the dealers from whom they are bought. When such a watch was taken the other day to a famous jeweler to be regulated the jeweler said: "It is very dry; you have not had it cleaned since 1891." "How do you know that?" asked the owner. "We put a private mark at an inconspicuous point whenever such a watch as this is cleaned," answered the man, "and the latest date your watch shows is 1891."

### Electrical Fountain in a Jewelry Window.

MANY of THE CIRCULAR's readers will remember the wonderful effect of the electrical fountain at the World's Fair. A very good reproduction in miniature of this fountain is now to be seen every evening in the show window of H. C. Graffe's jewelry store, Fort Wayne, Ind.

Ed. Alexander is the ingenious mechanic who contrived this really remarkable exhibition of the possibilities of producing colors in the spray of a fountain, and his success is a tribute to his skill and taste in the preparation of the machinery and the blending of the colors.

### A Good Advertising "Poem."

KEEP this "poem," used by John D. Leys, Butte, Mon., on hand for future use as an advertisement:

#### LEYS WILL SHOW YOU.

To the Ladies: We are sure  
Leys will politely show your  
Husbands, uncles, fathers and brothers,  
He—yes, he'll show your lovers,  
Just the catchiest little watches,  
Raised or smooth cases, and no botches,  
Inlaid diamond cases, really,  
And the price would knock one silly,  
When, in despair, a man has troubled  
His brain long, until he's muddled,  
And his pocketbook has fumbled,  
"O, what to buy for her!" has mumbled—  
Leys will show him.

There is a dagger now at Leys',  
Made of gems so fair. Who sees  
This bright jewel will declare  
'Twas made up by the fairies there.  
In its head a ruby bright,  
'Round it diamonds throw their light;  
Finished off with pearls pure,  
Fastened by a chain secure.  
By the dagger a necklace lay,  
Hung with diamond pendants gay.  
If you want to spend your money  
On the things that please your "honey,"  
Leys will show you.

Diamond earrings, wondrous fair,  
Are set with the greatest care,  
And a sun-burst pin so bright  
Makes Old Sol's a sickly light;  
And the bracelets—what a charm  
Thrown around a pretty arm.  
And a man seeks with elation  
Just that kind of occupation.  
O, what a length of time it takes  
To clasp a bracelet, while it makes  
An opportunity to buy the ring  
That follows on that sort of thing,  
And—see Leys' rings.

### Souvenirs of the Season.

"Suggestions for Presents" is a beautiful catalogue, published by W. H. Glenny, Sons & Co., Buffalo, N. Y. The pamphlet consists of about 50 pages, bound in an artistic cover of bottle-green tint, bearing the title in silver. The frontispiece is an inserted lithographic plate, showing Christmas specialties in their real colors—a fine piece of work. The index to the volume occupies one page, the lists of which are carefully made, with due regard not to over-value the articles in description. The pages are profusely illustrated with fine engravings. The various chapters are headed as follows: Lines of Goods; Specialties in Silver, subdivided into numerous headings—presents for women, presents for men, etc.; Suggestions—25 cents or less, 25 cents to 50 cents, up to \$200 and over.

Separate but slipped in the catalogue, is an order slip. The letter-press of the pamphlet is in olive ink, and altogether the catalogue is as fine a piece of work of its kind as we have seen this season.

\*

In the form of a wedding invitation, the reading matter printed in script type on regulation wedding note paper, the Christmas circular of P. M. Childress & Co., Valdosta, Ga., was unique. It was as follows:

MR. AND MRS. NECESSITY  
REQUEST YOUR PRESENCE  
AT THE UNION OF THEIR DAUGHTER,  
CHRISTMAS GOODS,  
TO  
LOW PRICES,  
ON ANY WEEK DAY BETWEEN  
7 A. M. AND 9 P. M. AT  
P. M. CHILDRESS & CO.'S JEWELRY STORE,  
PATTERSON ST.,  
VALDOSTA, GEORGIA,  
1894.

### Suggestions in Brief for Jewelers.

The show window of P. H. Stevens & Co., the new firm of jewelers in Bristol, Conn., is very attractive, and excites much admiration. A novelty on exhibition is a genuine deed of sale of a slave that was drawn in New Orleans in 1862. There are also good specimens of confederate currency.

The latest advertising scheme of J. C. Sipe, Indianapolis, Ind., was the distribution of unique thermometers mounted on a black background relieved by aluminum lettering.

As an attraction for holiday trade, G. W. Hill, Lodi, Cal., offered a gold watch to the customer guessing the number of parts the timepiece contained.

This ad. appeared in the newspapers of Indianapolis, Ind., the morning following the robbery of H. D. Burgheim's store:

#### HENRY D. BURGHEIM'S OPINION.

#### Henry D. Burgheim's Opinion of Sunday Morning's Burglary at No. 9 S. Illinois.

The man is as crazy as a lute. The beautiful display in the window dazzled the inebriate's eyes. Such has been the case with the people who saw the grand holiday array, who are perfectly sane. Crowds have been standing about my store and in it all day Saturday. The fellow had a good taste for art—mean the arrangement and class of jewelry. He simply, in fact, "simple," wanted to play Kris Kringle with himself. He was certainly sane on one subject; namely, that he could not have selected a handsomer window in the city. Had he healthy brains? No! For then he would have selected the Merchants' National Bank. That concern is rich. I am not, and all sane people know it. I have a rich line of holiday goods; the price is so low on them that it does not pay to rob me. The police did their work with dispatch, and deserve credit. I sell my goods for cash, however, and it will pay to visit old lucky No. 9, S. Illinois St. Don't let the broken window bother you.

### New Books of Interest.

**Deutscher Uhrmacherkalender**, für das Jahr 1895. [German Watchmakers' Almanac for the year 1895.] pp. 200, bound in flexible linen cover, 16mo., Berlin, W. H. Kühl, 73 Jägerstrasse. Price 2 marks.

THE CIRCULAR is under many obligations to the publisher for a copy of above named almanac, which makes now its eighteenth annual appearance on the reviewer's table, to remind him that another year has passed away. This pleasant little visitor, which for years passed under the name of Grossmann's Notizkalender (having been started by Mr. Grossmann), comes as usual, full of interesting matter on horological subjects, and sustains the high reputation of its predecessors. A partial enumeration of the contents will speak for its intrinsic merit.

The calendar proper; tables of the differences between mean and true time at true meridian; difference of time between German cities and towns; difference of time between foreign cities as compared to central European time; calculation of the size and weight of balances; the watchmaker as optician, &c. The technical part is followed by the laws on the instalment payments; the new law governing trademarks, and a number of other articles of great interest to the watchmaker, both as horologist and as merchant, etc. Next comes an extremely practical diary, just as is needed by watchmakers. THE CIRCULAR desires all prosperity to the almanac, and advises its German-reading subscribers to procure a

copy, by sending direct to the publisher, as above stated.

**Das Land der Uhrmacherei.** [The home of horology]. Agence de Publicité Horlogère, Rue Gutenberg 22, Geneva, Switzerland.

It is a very complete directory of all the addresses of firms engaged in the manufacture of watches, music boxes, watch materials, tools, bijouterie, etc., and contains the names and business of every factory in the various cities, towns, and hamlets of Switzerland, with the statement what specialty the firm is engaged in; next, all the specialties are arranged separately, with the names of the firms engaged in each. The directory also contains a complete list, occupying 20 pages, of all the trademarks (figures and designations) used by the different manufacturers; the most important laws and ordinances concerning the manufacture of watches, bijouterie, etc., of great interest to all parties engaged in making or dealing in the latter, as well as an entertaining description of "The home of horology," with numerous explanations about every locality, many statistical and comparative tables, etc.

The directory is a complete compendium, arranged on a broad, comprehensive basis, and invaluable to every business man engaged in the horological business, no matter in what country. Price, 3.75 francs, postage paid to all countries. Copies can be obtained by addressing above named firm direct. No business man should be without a copy.

The next issue in French (the one under

review being in German), will appear before the commencement of the National Swiss Exposition in Geneva in 1896. Terms of advertisement and other information are cheerfully furnished gratis on application.

The Philadelphia Record Almanac for 1895, is a comprehensive work of reliable information. Besides the customary calendar tables, the book contains household receipts; home hygienics; postal rates and regulations; lists of officials of the National Government, the State of Pennsylvania and the city of Philadelphia; Philadelphia vote by divisions; Pennsylvania vote for Congress, Pennsylvania election, 1894; officials of New Jersey, Delaware, Maryland; the American turf, intercollegiate football, best bicycle records, baseball championship, etc.; general and local events for the year 1894.

### Queries by Circular Readers.

*Editor of THE JEWELERS' CIRCULAR:*

Please inform me where I can obtain Brownie figures made of paper or pasteboard for window dressing purposes.

E. R. SIBERT.

ANSWER:—The Arnold Print Works, North Adams, Mass., we think, can furnish you the figures desired.

*Editor of THE JEWELERS' CIRCULAR:*

Would you be kind enough to look me up Mr. Frederick Benard? His former address 11½ years ago, was 237 West 37th St., between 8th and 9th Aves. He was a retail jeweler at that time.

JOHN I. BENARD.

ANSWER: The only Frederick Benard in the New York city directory is in the musical instrument business at 561 W. 50th St. There is no jeweler in the country of this name, in our knowledge.

**CHRYSO-CERAMICS,**  
GOLD COVERED PORCELAIN.  
**M. & E. HEALEY,**  
1122 CONNECTICUT AVE., WASHINGTON, D. C.  
MEDAL AT WORLD'S COLUMBIAN EXPOSITION.

**R., L. & M. Friedlander,**

Are now located on  
ground floor of

**30 Maiden Lane, N. Y.**



IMPORTERS OF

**DIAMONDS.**

WHOLESALE

**JEWELERS.**

JOBBERS IN

**American Watches.**

We have made great reductions in  
the prices of Watch  
Glasses.

SEND FOR PARTICULARS.

SEND FOR OUR NEW CATALOGUE.

**Improved Ear Piercer.**

THERE are a number of patented ear piercers, both improved and unimproved, with the latter of which, the technical editor being still a bachelor, may also be classed shrieking babies, he thinks, although as far as he knows, they are not yet covered with letters patent. THE CIRCULAR, however, is at present referring to the

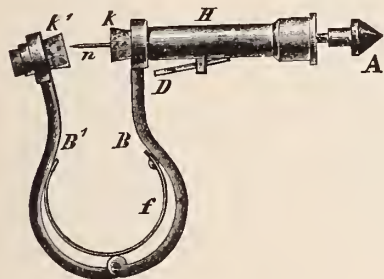

engine of war that pierces ladies' ears, as shown in accompanying illustration. The fearful weapon may be described as follows: An elastic bracket B B', kept open by the spring f, contains, each half, the small pieces of cork k k', between which the lobe of the ear is placed. The shell H contains the piercing needle n, which flies out by a pressure upon the trigger D, having brought the spring to full tension by pulling out the button A.

In order to have the hole pierced precisely at the desired spot which may be marked previously, there is within the strong cylindrical spring that forces out the needle n, still a second, but very feeble spring, which constantly presses the stem of the needle n, so far forward that this projects a certain length out of the cork k, even when the spring serving for shooting out the needle has already been brought at full tension.

The mentioned second spring is so delicate that the point of the needle is not at all felt upon the skin. The needle point n is therefore placed exactly upon the desired place of the ear lobe, the cork k is then laid

against the latter, whereby the needle n partly enters into the shell H. The other cork k' is then laid against the ear, while at the same time a pressure is exerted upon the trigger D. The needle n shoots out with lightning speed, and pierces the hole almost without pain.

If the least attention is paid, the case that the ear is pierced at a wrong place can never occur.

**Workshop Notes.**

**To Transfer Pictures.**—If you desire to transfer pictures from paper to wood for re-engraving, soak the print in a saturated solution of alcohol and white caustic potash to soften the ink; then transfer to the block under roller pressure.

**Argentine.**—The silvering fluid called argentine, is composed of 10 parts nitrate of silver, dissolved in 200 parts of water; then add 12 parts of sal ammoniac, 20 parts hyposulphate of potash, and 20 to 25 parts precipitated chalk.

**Green Bronze for Brass.**—Mix 80 parts of strong vinegar, one of mineral green, one of red umber, one of sal ammoniac, one of gum arabic, and one of green vitriol, and add four of Avignon berries (to be had in every dye store). Boil the mixture and strain, when cold. The articles to be bronzed should be cleansed with weak aqua fortis, then rinsed, and the fluid applied with a brush. Should the color not be dark enough, heat the article until it cannot be held in the hand, and then give a coat of spirits of wine mixed with a little lamp black. Finally apply a coat of spirit varnish.

**To Protect Metal Wares.**—Polished articles of iron, steel, bronze, or brass are best protected against rust or dimming by polishing them with joiners' polish and linseed oil, in the same manner as joiners polish wood. This procedure is adapted for all manner of highly polished metal wares, and especially for piano strings.

The knack is easily learned. If a little saffron is added for brass, it will receive a gold-like appearance. This must not be mistaken for the common way of "varnishing" by means of a brush. The inequality of such a coating is always disagreeable to the eye, while the other manner cannot be recognized except by expert eyes.

**Brass.**—A good method for drawing the temper from brass is to heat it to a red color, and then immerse it in water. It can be hardened by hammering.

**Hole Jewels.**—Hole jewels should be carefully felt of, under the eyeglass, to see if there is any shake either sideways or up or down. In burnishing the bezel to tighten a jewel, first burnish around the edges till the brass meets the jewel, then burnish the bezel over its face. When hole jewels are set in brass, the settings may be too small for their seats, and be held only by the pressure of screw-heads or set cap jewel upon their surface. All such should be tightened so that they fit snugly in place, even before the screws or caps are put in.

**To Clean a Brush.**—A watchmakers' brush is in constant requisition, still, it is seldom kept in proper order. A soft brush is useless for rough work, a hard one for fine work is ruinous, and a dirty brush for any kind of work is a nuisance. Some brushes are cleaned with dry bread; some by laying a piece of tissue or other paper across the wide open jaws of the bench vise, the sharp corners formed by the jaws taking off on the paper a little of the dirt. These methods are imperfect. A good way to clean a brush is with soap and water, warm water being preferable. Wet two brushes, soap them and rub them together in plenty of water, till perfectly clean. An objection to this method is the delay in drying. Apropos of brushes: much injury is done to the appearance of the watch movement by injudicious brushing, as the watch grows prematurely old in appearance by such a treatment.

**THE AMERICAN KNIFE AND SCISSORS SHARPENER.**



For Table Use.

Special Inducements to Jobbers

... Manufactured only by the

**MOSSBERG WRENCH CO.,**  
ATTLEBORO, MASS.

Makers of Novelties in Silver and Hardware.

- FOR SALE BY**  
 Benj. Allen & Co., Chicago, Ill.  
 F. M. Sproehle & Co., "  
 G. A. Webster, "  
 L. Straus & Sons, New York.  
 E. G. Webster & Son, "  
 Oskamp, Nolting & Co.,  
 Cincinnati, O.  
 Baldwin, Miller & Co.,  
 Indianapolis, Ind.  
 Eliassof Bros. & Co.,  
 Albany, N. Y.  
 Thos. Long & Co., Boston, Mass.  
 Smith & Patterson,  
 Dame, Stoddard & Kendall,  
 Boston, Mass.

**Practical and Handsome.**

A Silver Plated Knife and Scissors Sharpener, retailing at a popular price. Perfect in action, nothing to wear out. Cutting discs of finest hardened steel. An ordinary sharpness or a RAZOR EDGE can be acquired in a few moments.



TWO-THIRDS SIZE.  
FOR DESK USE.

### A Parisian Diamond Trick.

ONE of the foreign travelers of a famous jewelry house in this city has just returned from his annual trip abroad, and upon reading of a clever shoplifter's trick executed here, told of a bold and clever diamond robbery in Paris that borders on high art.

The swindle was perpetrated in a diamond shop on the Rue de la Paix, one of the busiest centers of the trade in Paris. A stranger came in and told the proprietor that he had found a stone among his family effects, which had been there a great many years, and the value of which he was anxious to know. He said he didn't suppose it could be worth very much, as otherwise it would not be found among his family possessions. The jeweler took the diamond out of the soiled paper in which the stranger brought it, and examining it closely with a strong glass, seemed surprised. Hesitating a moment he stepped into his private office to show it to another expert. Returning he said:

"Why, sir, that is not only a good stone, but a remarkably clear one and very valu-

able."

The stranger laughed incredulously, remarking lightly: "Nonsense; it may be a fine imitation, but certainly not a real diamond, for how would it get into the possession of my family, who were always poor? And how could it lie among our effects undisturbed for so many years?"

The jeweler assured him that it certainly was a diamond and a gem of the first water, and added that if the owner would leave it for a day or two he would show the stone to other jewelers and get their opinion. The owner agreed to this and two days later called again. The diamond merchant promptly repeated his assertion as to the purity of the stone, and added that it was worth at least 18,000 francs.

"Well," the owner replied, "I can't believe you yet, for I am certain it must be an imitation, no matter how good it looks; but I want to sell it, and if you are willing to buy it, how much will you pay for it and take your chances on the stone?"

"Well, under the circumstances, I will give 17,000 francs for the stone," the merchant replied.

"And when can I get the money or your

check for it?"

"You may call in a day or two."

The jeweler was not a novice in business; moreover, he was a Parisian of the purest type, and in matters of business was as shrewd as any of his brother merchants in that busy city. He took no chances, and, to make doubly sure of his bargain, he put the stranger off again, and in the interval not only removed all possible doubt as to the genuineness of the stone, but also found at least two very willing purchasers at a handsome advance over what he had offered. Therefore, when the stranger paid his final visit the jeweler had the stone in his safe, and with it a check all filled out. As the jeweler turned to hand the check over to the stranger, the latter said with half a sigh:

"Well, if I must part with it, let me have one last look at it."

The check still lay on the counter as the stranger picked up the paper containing the gem and slowly opened its folds. Then, after a long look, with a heavy sigh, he folded the paper again and handed it back to the jeweler.

As the jeweler started to make out a receipt for the money the stranger said: "Now, it is not very clear in my mind that this can be a genuine stone, and as I am very peculiar about some things please make your receipt read: 'Received for one imitation stone 17,000 francs,' for I can never believe that our family ever possessed anything else."

"That is a strange peculiarity of yours," the jeweler replied, "but I don't know that it makes much difference."

The receipt was made out as the stranger desired, who signed it, and the jeweler deposited the paper containing the stone with the receipt once more in the drawer of his safe.

The following day a friend called, the recent purchase was spoken of, and the paper containing the stone was brought out. As the jeweler took out the stone his face grew pale.

"Mon Dieu!" he cried. "My money! my money!"

The closer he now examined the stone the more evident it grew that the stone was really an imitation after all, and as he sank down in his chair and read the wording of his receipt and then recalled all the circumstances and how the stranger took one last long look at the treasure, it became clear to him that in that moment he was robbed and an imitation substituted for the good stone before his very eyes.—New York Sun.

# ARNSTEIN BROS. & Co.,

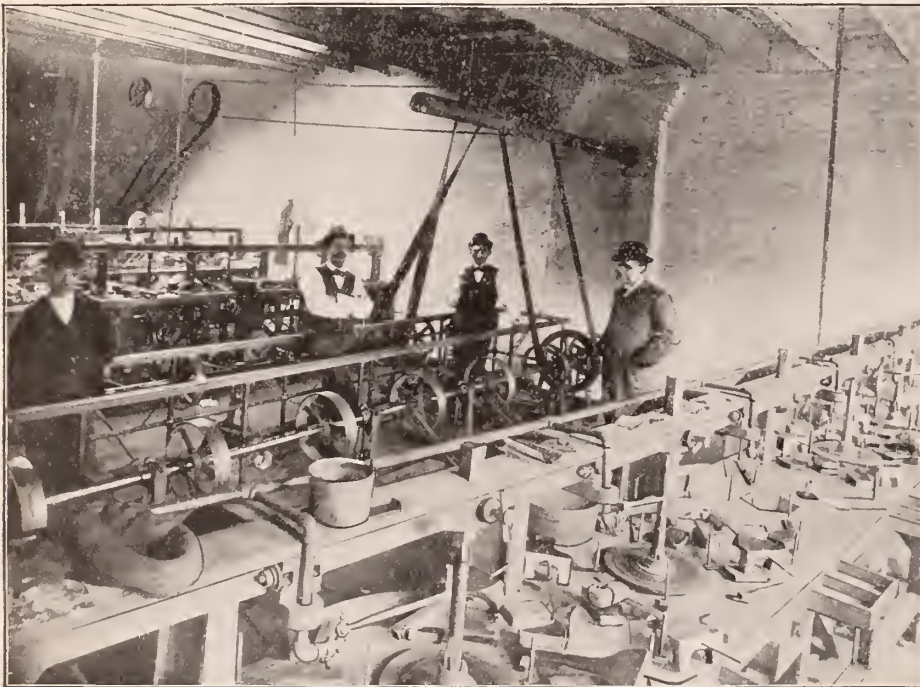

VIEW OF THE DIAMOND CUTTING WORKS OF ARNSTEIN BROS. & CO.

IMPORTERS  
AND CUTTERS OF

## DIAMONDS.

CUTTING WORKS, 43 JOHN STREET.

# 37 MAIDEN LANE, NEW YORK.

Though glass was principally used for fancy work in Egypt, it was also employed in the manufacture of vases and other utensils, but especially wine cups. In the later ages, when the Romans conquered Egypt, the glass vases nearly superseded those of gold and silver; indeed, some of them were so exquisitely wrought that they were more valuable than if they had been formed of the precious metals.

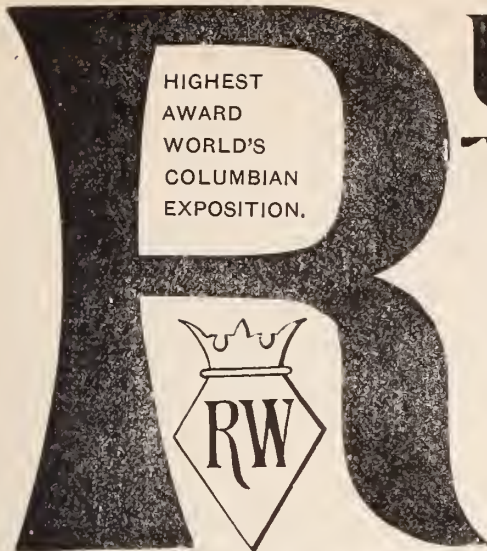

# RUDOLSTADT

## ART POTTERY.

CONTAINS all the elements re-  
quired as to designs, deco-  
rations and workmanship, in a high  
grade of Art Goods adapted to the  
Jewelry Trade, and yields a larger  
margin of profit than any other  
class of Pottery.

### L. Straus & Sons,

SOLE AGENTS,  
42-44-46-48 Warren Street,  
116 Chambers Street,  
NEW YORK.



..THE LATEST..  
Sterling Silver Novelty,  
CIGAR CUTTER  
AND KEY RING COMBINED.  
Patented Nov. 20th, 1894.  
WITH OR WITHOUT CHAIN.

MADE ONLY BY  
ENOS RICHARDSON & CO.,  
23 Maiden Lane, New York.

### SAFES FOR JEWELERS.

MOSLER, BAHMANN & CO., 518 BROADWAY  
NEW YORK.  
Patent Fire and Burglar Proof Safes.

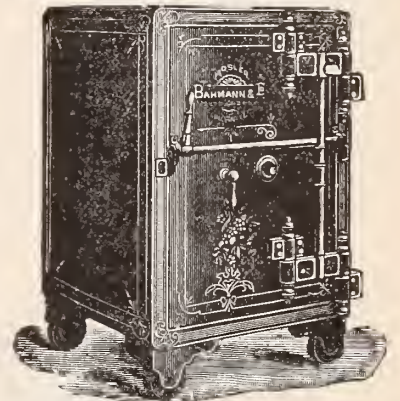

Large Assortment Always on Hand.  
Send for our Representative.  
Special Safes to Order.  
Jewelers' Safes a Specialty.



SPECIAL SALESMAN OF  
WATCHES, DIAMONDS,  
Bric-a-Brac  
and Art Goods  
FOR  
Established Jewelers.

WRITE FOR PARTICULARS.

Communications Strictly Con-  
fidential.

Referenc s given in all parts of the  
United States from Retail-  
ers and Jobbers.

### CROUCH & FITZGERALD.

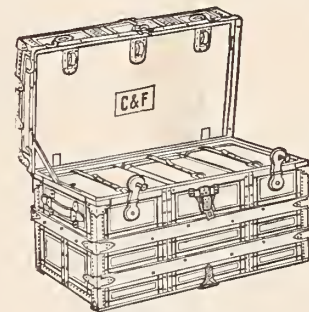

Jewelry Trunks  
and Cases,  
161  
Broadway,  
Bet. Cortlandt and  
Liberty Sts.,  
688 B'way,  
701 6th Ave.,  
NEW YORK.

CODDING BROS. & HEILBORN,  
North Attleboro, Mass.

Makers  
OF

QUICK SELLING NOVELTIES  
In Sterling Silver.

NEW YORK OFFICE—C. A. Vanderbilt, 178 Broadway.  
CHICAGO OFFICE—F. A. Buck, 103 State Street.

H. M. RICH & CO.,  
Jewelry · Auctioneers,  
21 School Street.  
BOSTON. MASS.

JACOT & SON  
IMPORTERS AND  
MANUFACTURERS  
OF  
MUSICAL BOXES  
ORPHEUS

39  
Union Sq.  
New York.



# FERDINAND BING & Co.,

106 GRAND ST., N. Y.

NEW DESIGNS IN \_\_\_\_\_

China Clocks and Gilt Bronze Sets, Fine Painted

Dresden Goods in Vases, Cups and Saucers, and Plates;

Cararra Marble Statuary, French Cabinets and other

Fancy Furniture.

**TOWLE MFG. Co.,**  
Silversmiths.



FACTORIES:

NEWBURYPORT,

MASS.

CHICAGO OFFICE, 149-151 STATE ST.

**FLAT WARE AND  
HOLLOW WARE**

STAMPED



IS THE GENUINE.

Manufactured by

**WM. ROGERS M'FG CO.,**  
HARTFORD CONN.

## **BOYLE, DAVIS & GOODMAN,**

*SPECIAL AUCTIONEERS for the Legitimate Trade only.*

**88 Fifth Avenue  
NEW YORK.**

**611 Pennsylvania Ave.,  
WASHINGTON, D. C.**



S. A. BOYLE.



W. M. DAVIS.



CHAS. P. GOODMAN.

**WE PAY ALL OUR OWN EXPENSES. GUARANTEE TO MAKE YOUR SALE WITHOUT LOSS.**

SEND FOR OUR BUSINESS PAMPHLET.

CONSULT US BEFORE PLACING YOUR SALE. ADDRESS ALL CORRESPONDENCE TO OUR WASHINGTON OFFICE.





## BRIC-A-BRAC.

**T**HE tramp went up to the cottage door  
To beg for a few coppers or more.

The cottage door was open wide,  
So he took a cautious look inside.

Then over his features there spread a grin,  
As he saw a lovely maid within.

A lovely maid within the gloom  
Of the shadiest part of a shady room.

Into the door the trumper went;  
Over a dog the maiden bent.

His eyes were set and full of fire,  
And he viewed the tramp with evident ire.

"Run for your life!" the maiden cried:  
"I clean forgot to have him tied!"

"Run for your life through yonder door—  
I cannot hold him a minute more!"

Without a word he turned his face,  
And leapt the fence with a careless grace.

Then lightly along the road he ran—  
A very-much-put-out young man.

The maiden loosed her bull-dog's neck,  
And gazed at the tramp—a vanishing speck.

And peal after peal of laughter rent  
The air with the maiden's merriment.

That dog was of terra-cotta ware—  
She won him that week at a lottery fair.

—Pottery Gazette.

## Old Egyptian Pottery.

**P**OTTERY among the Egyptians was a more honorable employment than brickmaking. The Egyptian potters were eminent for their artistic skill. Their vases are fully equal to the most beautiful specimens of Greece and Etruria. Indeed, there is every reason to believe that both these nations originally derived the art of pottery from Egypt. The Egyptians were well acquainted with the manufacture of glass more than three thousand years ago. Of this we have the clearest possible evidence, not only from numerous specimens of the articles found in the tombs and among the ruins of the temples, but also from the painted representations of the processes of manufacture preserved in the same situations, and from which the illustrations of the whole of them are to be found in most of the museums of Europe.

They were not only skilled in the art of fusing the materials, but also in the use of the blow pipe, an invention so ingenious that its presence alone indicates a very high degree of civilization. The fusion of glass was closely connected with the art of pottery, for many of the vases and fictile ornaments are glazed over with a vitrified substance containing also the proper proportions of the ingredients for making glass.

It was generally believed by the ancients that Egypt produced a peculiar species of earth without which glass of the best quality could not be manufactured. It is not easy to discover the nature of this substance from the loose descriptions transmitted to us; but it is said that the beads and ornaments formed from it possessed all the lustre and brilliancy of the diamond. The specimens of Egyptian beads preserved in the different museums of Europe show that this description is far from being exaggerated. In some of them colors are blended with more exquisite skill than in any specimens of modern art with which we are acquainted, and in others pieces of colored glass are made to form beautiful mosaics—an art which is now rarely practised, on account of the great difficulty of finding a proper flux for the glass that many writers have doubted the possibility of the process.

It is singular that glass beads, as they are used by ladies in ornamental work, being round and long were in use in the days of Moses, just as they are by modern embroiderers. The oblong beads, or as they are usually called, bagles, were strung into a great variety of fanciful patterns. In the Egyptian collection in the Paris Museum there is a lady's reticule, formed of bagles, whose workmanship is of extraordinary beauty. The sacred beetle of the Egyptians is a conspicuous ornament in the centre, and at the sides there are figures of stags, wrought with a life and spirit which could scarcely be expected from such a mechanical process. The glass manufacturers of these ancient days were skilful in the art of counterfeiting precious stones. Specimens of these are frequently found in the tombs, and we find that the artists were most successful in imitating the rich green of the emerald and the brilliant purple of the amethyst.

## The Rambler's Notes.

WHAT THE RAMBLER SAW AND HEARD AMONG THE  
DEALERS IN ART POTTERY, CUT GLASS,  
BRONZES, ETC.

IMPORT SAMPLES  
OF HACHE CHINA.

**I**N about ten days the Craighead Mfg. Co., 38 Park Place, New York, will commence opening and will put on display the new import samples of the china of Alfred Haché & Co., Vierzon, France, for which they are the American agents. Their new assortment promises to be the largest they have ever shown.

THE EMPIRE CUT  
GLASS CO.

**T**HE Empire Cut Glass Co., who recently started a factory at 145 Eleventh Ave., New York, have hired an office in the Para building, corner Church and Warren Sts., which they will occupy some time before Jan. 1, 1895. This down-town office being in the heart of the pottery and cut glass district will, it is expected, prove of great advantage to the company and to their patrons.

POPULAR LIMOGES  
NOVELTIES.

**A**MONG the lines successful as holiday presents none have been more popular than the Limoges novelties of P. H. Leonard, 76 Reade St., New York, pre-



LOUIS XVI ALMOND TRAY.

viously mentioned in these columns. The trays of this line, in particular, comprise a variety in style, shape and decoration never before surpassed. Among the various shapes shown in the comb, brush, desk, pen, pin, ink, almond, olive and ring

trays, probably the most beautiful styles were the Richfield, Psyche, Lys, Rose and Louis XVI., shown in the almond tray here illustrated.

**HEADQUARTERS FOR FINE BRONZES.** **A** FEATURE for which the ware-rooms of Ferd. Bing & Co., 106 Grand St., New York, have become noted in the jewelry trade, is the extensive assortment of bronzes which this firm always keep on display. Statues, figures, groups, ornaments and sets in French, Russian and other bronzes are always here to be found in all the latest and leading finishes. Among the newest pieces lately added to this collection, which is always up to date, are "En Vidette," a beautiful four foot statue of a Goth hunter, by Maureau; a bust of "Sappho," in silex, a new grey-green finish; "Les Lauriers," shown in several finishes; the pair of female figures, "Peace and War," and a large number of smaller figures, subjects by Obiorles, Maureau and others.

**NEW FRENCH FAIENCE.** **A** NEW and attractive line of French faience was last week opened by Chas. Ahrenfeldt & Son, 52 Murray St., New York. The pieces are candlesticks in several sizes and shapes, violin, fleur-de-lis and other shaped bonbon boxes, inkstands, mirrors, plaques and letter holders. The decoration shows the style and bright colors of the Italian faience. Candlesticks and other smaller novelties of this ware such as cane heads, umbrella heads and seal handles are also shown with a Delft blue decoration.

THE RAMBLER.

**The Other Side of Life.**

**A CHRISTMAS SURPRISE.**

**S**HE asked her experienced father, "Dear papa, tell me, I pray, What shall I give my husband To surprise him on Christmas day?"

"A present for Clarence?" he murmured, His mind with past years away, As he thought of his wife's dear presents, For which he had had to pay.

"This is sure to surprise him, daughter, If there's anything that will— A gold watch and chain to give him— And include a receipted bill."

—Judge.

**QUITE A DIFFERENT MATTER.**

**MISS BLANC** (contemptuously)—That's a nice looking watch; did you have to buy a suit of clothes to get that?

**JOHN WARE** (reflectively)—No; on the contrary. I had to sell one.—*Harvard Lampoon.*

**AN INFERENCE.**

**MRS. JACKSON**—Did you see Mrs. Brown's collection of rare old china?

**JACKSON**—Yes; her family must have been quite poor.

**MRS. JACKSON**—Nonsense. Why do you think so?

**JACKSON**—Well, if they had been able to keep servants, she never would have had that collection of rare, old china.

—Puck.

**HEARTLESS.**

There is nothing like the heartlessness of a man. There is a pretty little bride here in Washington who is just coming to know

that. She fell out with her newly acquired husband the other day. I forget quite what it was about, but it seems to me he had said things about a new gown of hers. At any rate, life was no longer worth living. She shut herself in her room and cried till her head ached. Then she bathed her eyes, brushed a fluff of powder over her red and swollen nose, and called icily to her husband:

"Fred," said she, "bring me a spoon, please; I'm going to take poison."

"Yes, dear," answered the heartless monster from below; "do you want a teaspoon or a tablespoon?"—*Washington Post.*

**LIKE PEARLS.**

She's the handsomest of girls, And her teeth are just like pearls, Which is hardly an original thing to say; Yet, like pearls, they are white, And, to her intense delight, They are often found in oysters nowadays.

—Indianapolis Journal.

**GRATIFYING HER CURIOSITY.**

**Mrs. Dusenberry** was toying with the Masonic seal on her husband's watch chain.

"What do those letters stand for?" she asked with a pleading look.

"What do they stand for? I suppose it is because they can't sit down."—*Texas Siftings.*

**FERD. FUCHS & BROS.**

**SILVERSMITHS,**

MAKERS OF STERLING SILVERWARE,

808-810 Greenwich St., New York.

For **BADGES and MEDALS,**

Flag Pins, Class Pins, Class Rings and Special Work of all Descriptions,

SEND TO **E. R. STOCKWELL, MANUF'R,** 19 John Street, New York.

**Jules Jürgensen**

OF COPENHAGEN.

The reputation these watches have maintained for Fifty Years has never been equalled, being made on strictly scientific principles and no expense spared to give the Best results in mechanism and timekeeping qualities.

SOLE AGENTS,

**John C. Hyde's Sons,** NO. 22 MAIDEN LANE.

**HAVE YOU RECEIVED OUR PRICE LIST?**  
—OF DIAMOND MOUNTINGS.—

If not, send your business card and we will send you one.



Manufacturing Jewelers,  
OFFICE AND FACTORY,

**LEONHARDT & CURRAN,** 57 Maiden Lane, New York.

**WM. SMITH & CO.,**

Manufacturers of Gold, Silver and Roll Plate Chains and Jewelry.



Novelties in Gold and Silver Bead Necklaces and Bracelets. Also a large line of Chain Trimmings and Silver Rings.

Office: 5 and 7 Maiden Lane, New York. **Manufactory: 61 Peck Street, Providence, R. I**

**AIKIN, LAMBERT & CO.,**

CHICAGO BRANCH: 103 State Street.

No. 19 MAIDEN LANE, NEW YORK.

Manufacturers and Exporters  
Gold Pens, Holders, Pencils,



Toothpicks and Novelties

**MERCANTILE**



**FOUNTAIN PEN.**

# The Best Chatelaine is the Lady Racine.

**STEEL CASES & SILVER CASES.**



10 LINE.

Made in 10 Line Open Face.  
 " 11½ Line Open Face and Hunting.  
 " 13 Line Open Face and Hunting.

THE SILVER CASES ARE 0.935 FINE.  
 THE MOVEMENTS HAVE 10 JEWELS  
 THE ENGRAVINGS ARE CHOICE.



13 LINE

## MADE IN 12 LINE OPEN FACE.

In Silver Cases only.

Case 0.800 Fine with a 6 Jewel Movement.  
 Expressly Gotten Up to Suit the Times.



12 LINE

A GOOD Chatelaine Watch at a LOW PRICE.

Do not fail to ASK YOUR JOBBER FOR THE NEW  
 12 LINE LADY RACINE in 0.800 Cases.

# CARBORUNDUM.

## Net Retail Price List of Carborundum Wheels.

ACCESON'S PATENT, February 28th, 1893.

Diam. in Inches	THICKNESS IN INCHES.																Rev. per Minute.	
	¼	⅜	½	⅝	¾	⅞	1	1¼	1½	1¾	2	2¼	2½	2¾	3	3½		4
1	\$.15	\$.18	\$.20	\$.23	\$.25	\$.28	\$.30	\$.35	\$.40	\$.45	\$.50	\$.55	\$.61	\$.65	\$.70	\$.80	\$.90	18,000
1½	.18	.22	.25	.28	.31	.33	.35	.40	.45	.50	.56	.62	.67	.73	.78	.90	1.00	14,000
2	.29	.35	.38	.42	.46	.48	.50	.55	.60	.65	.70	.77	.85	.91	1.00	1.20	1.40	11,000
2½	.25	.30	.37	.42	.46	.48	.50	.55	.60	.67	.75	.80	.91	.98	1.05	1.20	1.40	8,800
3	.30	.38	.45	.50	.55	.58	.60	.65	.70	.78	.85	.95	1.05	1.15	1.25	1.45	1.65	7,400
4	.65	.70	.75	.80	.85	.90	.95	1.10	1.30	1.50	1.65	1.80	2.00	2.15	2.35	2.70	3.05	5,500
5	.85	.90	.95	1.05	1.15	1.25	1.35	1.65	1.90	2.20	2.45	2.75	3.05	3.30	3.55	4.15	4.65	4,400
6	1.10	1.20	1.25	1.45	1.60	1.80	1.95	2.35	2.75	3.15	3.55	3.95	4.33	4.75	5.15	5.95	6.75	3,700
7	1.35	1.55	1.70	1.90	2.10	2.35	2.60	3.15	3.70	4.25	4.80	5.35	5.75	6.45	7.00	8.10	9.20	3,160
8	1.65	1.90	2.15	2.45	2.75	3.05	3.35	4.05	4.80	5.50	6.25	6.95	7.65	8.35	9.10	10.50	12.00	2,750
9	2.00	2.40	2.65	3.10	3.40	3.80	4.15	5.10	5.45	6.90	7.80	8.75	9.65	10.55	11.45	13.25	15.10	2,450
10	2.45	2.80	3.25	3.70	4.15	4.65	5.10	6.25	7.40	8.50	9.60	10.70	11.85	12.90	14.05	16.30	18.55	2,200
12	3.60	4.00	4.40	5.10	5.80	6.50	7.20	8.80	10.40	12.00	14.60	15.20	16.80	18.40	20.00	24.55	26.40	1,830

CARBORUNDUM was awarded both a Medal and a Diploma at the World's Columbian Exposition in recognition of its merits as an Abrasive, the hardness being greater than any other abrasive material.

The wheels are made with a vitrified bond, and pressed under hydraulic pressure. Those over three inches in diameter are turned up after firing. The same numbers are used to designate the degrees of fineness, as are used with Emery, and the wheels are made in seven degrees of hardness, marked SSS, SS, S, M, H, HH, HHH, from extremely soft to extremely hard.

In ordering, state diameter, thickness, hole, number and hardness.

Monongahela, Pa., U. S. A.

THE CARBORUNDUM COMPANY.

Hones, Slabs, Files.

Cut = This = Out.

IMPORTERS OF  
**DIAMONDS.**

JOBBERS IN  
 Watches, Jewelry, Chains,  
 NOVELTIES, ETC.  
 Latest Designs. Lowest Prices.

**AIKIN-LAMBERT**  
 JEWELRY CO.,  
 19 Maiden Lane, New York.  
 CHICAGO BRANCH: 103 STATE ST.

**TORQUOISES**

**E. KIPLING,**

182 Broadway, New York.

ELEVATOR ENTRANCE, 2 JOHN ST.

**S. F. MYERS & CO.,**

Manufacturing and  
WHOLESALE JEWELERS,  
1895 Issue, No. 39.

**OUR ROYAL CATALOGUE**

Illustrates all that is new, unique  
and desirable in

everything that pertains to jewelry.  
600 pages, size of this publication.  
Free to dealers.

SEVEN DOUBLE FLOORS.  
TWENTY-TWO DEPARTMENTS.

48-50 Maiden Lane,  
Myers Buildings, 33-35 Liberty St., New York.



OUR SPECIALTY  
The Largest Stock of  
CHIMING  
AND  
STRIKING  
HALL CLOCKS

ever shown.

Chas. Jacques  
CLOCK CO.,  
22 Cortlandt Street,  
NEW YORK.



**B. & W. B. SMITH,**  
220 W. 29th St., New York.

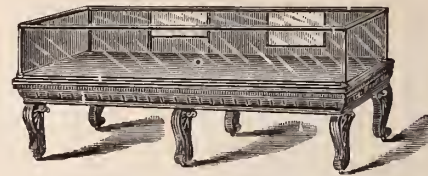

Improved Dust-Tight Counter Cases,  
Perpendicular Sliding Doors.

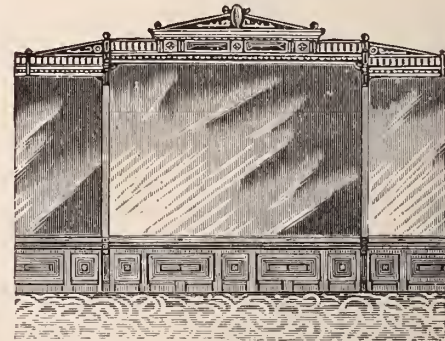

Improved Dust-Tight Wall Cases.  
Furnished with Improved Shelving and ar-  
ranged for Electric Lighting.

Sold by all whole-  
sale dealers at manu-  
facturer's price.

**A. N. CLARK & SON**  
PLAINVILLE  
CONN.

Manufacturer of the Celebrated  
**LOOP WATCH KEY.**

The Best for the Price in the World.  
CROSBY'S JEWELING TOOLS IMPROVED.

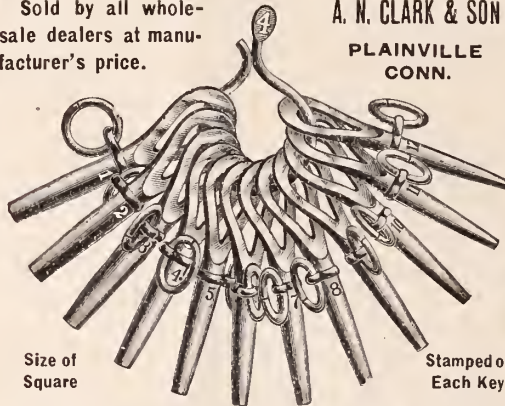

Size of  
Square

Stamped on  
Each Key.

Will quote royalty or price for the manufacturing of articles of real worth.



**PRESCRIPTION WORK.**  
**QUEEN & CO.,**

1010 Chestnut Street, PHILADELPHIA.  
SEND FOR PRICE-LIST AND ORDER FORMS.

**U. S. SMELTING & REFINING WORKS.**

Sweep Smelting and Assaying, Platinum in Plate and  
Wire. Chemically Pure Copper. Ore and Bullion  
Assays a specialty.

Highest prices paid for old gold and silver.  
Sole manufacturers of Phoenix Flux  
and Eureka Alloy.

M. WOLLSTEIN. 25 John St., New York.

**L. LELONG & BRO.,**

GOLD AND SILVER

**Refiners, Assayers AND Sweep Smelters,**

SOUTHWEST CORNER HALSEY AND MARSHALL STREETS,

**NEWARK, N. J.**

**SWEEPINGS A SPECIALTY.**

**ALBERT LORSCH & Co.,**

37 MAIDEN LANE, NEW YORK.

Branch, 167 Weybosset Street, Providence, R. I.

IMPORTERS OF DIAMONDS,

Rose Diamonds, Rubies, Sapphires, Emeralds, Opals, Moonstones,  
Fancy and Imitation Stones, Novelties.

SOLE OWNERS AND IMPORTERS OF

*The Sumatra Gem.*

REG'D. UNEQUALLED IN  
BRILLIANCE AND  
HARDNESS

HIGHEST AWARD AT THE COLUMBIAN EXPOSITION, CHICAGO, 1893.

IT PAYS TO KEEP IN TOUCH WITH TRADE AFFAIRS. THE JEWELERS' CIRCULAR. For 4c. a Week will do it. **Subscribe.**

DIAMONDS and Cutters. L. & M. KAHN & CO., 177 Broadway, NEW YORK.

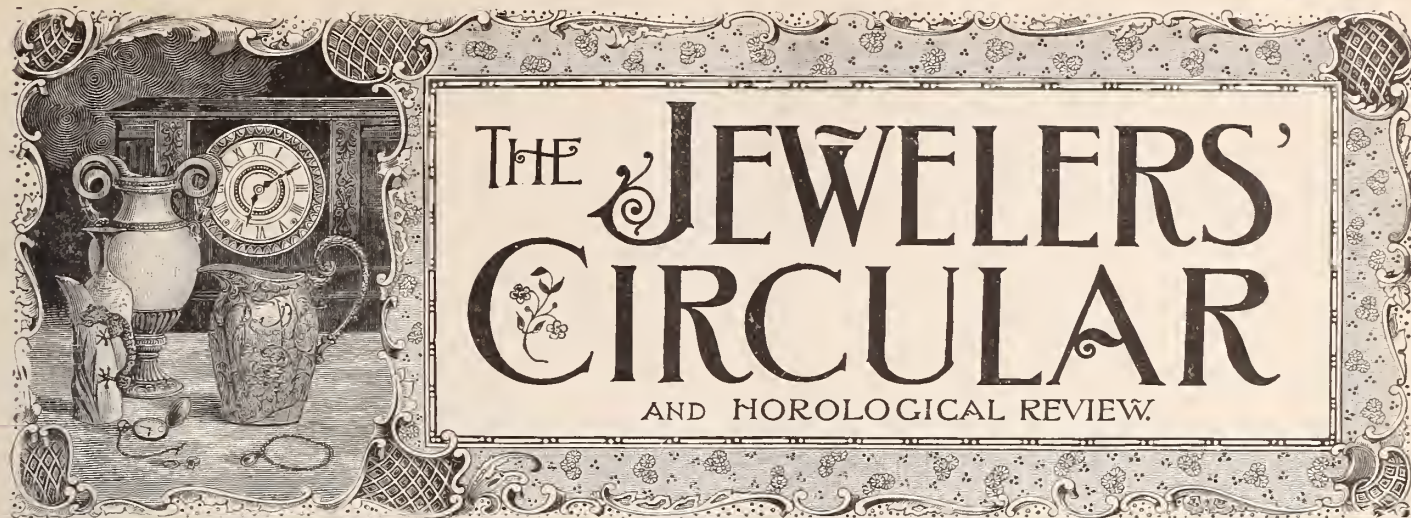

Copyright by THE JEWELERS' CIRCULAR PUB. CO.

189 Broadway, New York.

Entered at the Post Office in N. Y. as second-class matter.

VOL. XXIX.

NEW YORK, WEDNESDAY, JAN. 2, 1895.

No. 23.

THE EMPLOYMENT OF ENAMEL EFFECTS IN SILVERWARE.

THE increasing appreciation of enamels has resulted in the production of some beautiful examples of enamel and gold and enamel and silver-gilt effects. The pronounced whiteness of pure silver appears to deaden many of the color schemes when used in its natural color, but when the silver is gilded the warmth of the gold seems to permeate the design and enhance the beauty of the work to a most gratifying degree.

In a recent example, in the shape of a presentation set of nine pieces, the design-

style approximating a chastened Colonial and Queen Anne. The double curve was selected because of its resultant play of lights. In the spout on the teapot the same *motif* has been used, and both handle and spout are fluted to match the body lines.

The enameling on each piece is contained within two bordered shields, only one of which appears on the pieces in the illustration. The dainty floral design is accentuated by a delicately tinted background and shows roses, forget-me-nots, violets and lilies-of-the-valley, with a dain-

ture greater than that developed in any furnace, when softened by the intense heat of the oxyhydrogen blow-pipe, may be drawn out into threads of incredible fineness. Prof. Boys manipulates it by using a cross-bow arrangement, by which a straw, used as an arrow, carrying a small bit of quartz rod, is joined to another rod of quartz by melting the point of contact. When the straw arrow is fired from the cross-bow it draws out the quartz into a thread which may be made of almost any desired thickness, of any uniform diameter, and remark-



PORTION OF A PRESENTATION SET OF SILVER WITH ENAMEL DECORATIONS.

ers and makers, Reed & Barton, Taunton, Mass., have been particularly fortunate in combining beauty, color and grace in artistic design and execution. The accompanying illustration depicts three of the pieces, but the monotone of the engraving cannot, of course, do more than convey an idea of the harmonious color blending in the playing lights and shades of the original. The shape of the pieces is virtually a new one, being a combination of the hexagonal ware with some modified *motifs* of the Charles II. period, the result being a

tinness of touch and execution that proclaim the master hand of an artist. The material is silver heavily gilt, and the set in its entirety is a *chef-d'œuvre*.

Finest Fibers Made.

THE finest fibers said to have been ever made have been spun by Prof. Boys, out of quartz. This highly refractory substance, which requires to melt it a tempera-

ably strong, considering the fineness.

Fibers  $\frac{1}{15000}$  of an inch in diameter have been made, a hundred of which only equal in size the thickness of a single silkworm's thread, and the ends as they are drawn out become so fine that they cannot be seen, even with the aid of the most powerful microscope, and are not thicker than the millionth of an inch. A single cubic inch of quartz would supply sufficient thread to go around the world no fewer than 658 times—in other words, the length would be 16,450,000 miles.

THE AMERICAN KNIFE AND  
SCISSORS SHARPENER.

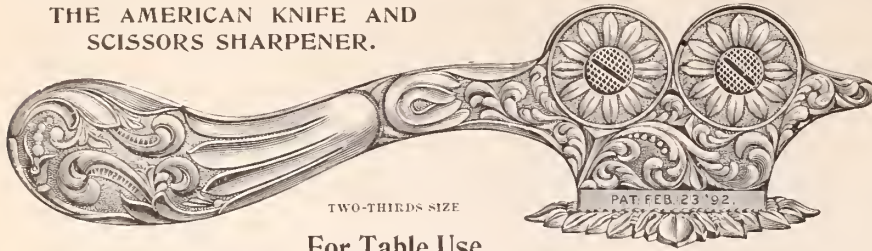

TWO-THIRDS SIZE

For Table Use.

Special Inducements to Jobbers

... Manufactured only by the

**MOSSBERG WRENCH CO.,**  
ATTLEBORO, MASS.

Makers of Novelties in Silver and Hardware.

**Practical and Handsome.**

A Silver Plated Knife and Scissors Sharpener, retailing at a popular price. Perfect in action, nothing to wear out. Cutting discs of finest hardened steel. An ordinary sharpness or a RAZOR EDGE can be acquired in a few moments.



TWO-THIRDS SIZE.  
FOR DESK USE.

FOR SALE BY  
Benj. Allen & Co., Chicago, Ill.  
F. M. Sproehle & Co.,  
G. A. Webster,  
L. Straus & Sons, New York.  
E. G. Webster & Son,  
Oskamp, Nolting & Co.,  
Cincinnati, O.  
Baldwin, Miller & Co.,  
Indianapolis, Ind.  
Eliassof Bros. & Co.,  
Albany, N. Y.  
Thos. Long & Co., Boston, Mass.  
Smith & Patterson,  
Dame, Stoddard & Kendall,  
Boston, Mass.



THE QUESTION ?  
WILL IT TARNISH ? Need  
not be asked if your Tissue Paper bears  
this label.

MANUFACTURED BY

**C. H. Dexter & Sons,**

WINDSOR LOCKS, CONN.

◁ BE SURE YOU GET THIS BRAND ▷

It has been adopted and is now used by the leading  
manufacturers of this country.

**OPPENHEIMER BROS. & VEITH,**  
35 MAIDEN LANE, - NEW YORK.  
CUTTERS OF DEALERS IN  
**DIAMONDS, WATCHES.**

HAMPDEN MOVEMENT, DUEBER CASES A SPECIALTY.



**H. H. HEINRICH,**  
14 John St., N. Y.  
MARINE  
Chronometers

for Rent and Sale.  
Large Stock on Hand.  
Springing, Readjusting and  
Repairing for the trade.

Easy Terms. Send for Price List.

No Jeweler or Watch Repairer should be without  
a copy of "WORKSHOP NOTES," a new and very  
useful book for the workshop. Send for circular  
containing a complete index of the book, and judge  
of its merits for yourself.

IMPORTERS OF  
**DIAMONDS,**  
JOBBER IN  
Watches, Jewelry, Chains,  
NOVELTIES, ETC.  
Latest Designs. Lowest Prices.

**AIKIN-LAMBERT  
JEWELRY CO.,**  
19 Maiden Lane, New York.  
CHICAGO BRANCH '03 STATE ST.



# FOSTER & BAILEY,



100 RICHMOND ST., PROVIDENCE, R. I.

Manufacturing Jewelers and Silversmiths.

925/1000.

HEADQUARTERS FOR MANICURE GOODS.



Garters

Link Buttons

Scissors

Neck Chains

Bag Tags

Glove Buttoners

Hat Marks

Chain Mountings

Pen Wipers

Shirt Waist Sets

Emery Balls

Crosses, Earrings

Match Boxes

Solid Gold Locket

Coat Hangers

Locket and Charms

Pocket Knives

Silver Belt Buckles

Pocket Combs

"Mount Hope" Buttons

Paper Cutters

Bracelets and Padlocks

Seals, Button Hooks

Pins and Neck Buckles

And Silver Novelties

Rolled Plate Watch Chains

Without End, all Sterling.

$\frac{1}{10}$  Gold Vest and Dickens Chain.

And also those

**HANDY SETS FOR TOILET IN LEATHER ROLLS.**

## A Woman as a Silver Designer.

THE engraving herewith reproduces the South Kensington (London) prize cup design, conceived by Miss Fleanor L. Mercer, the most successful student in connection with South Kensington this year. This young woman won, among others, two prizes, gold medals, one for a modeled design for a gold cup, and the other for a sheet of designs of silversmith's work. Miss Mercer has had an unusually brilliant career as an art student, and promises to take a high place in the ranks of designers. Born in 1871, she entered the Sheffield School of Art, at the age of 15 years, and devoted her attention to designing for silver work. For this purpose she went through a course of training in repoussé work. In 1891 she gained the scholarship then founded of £52 per annum offered by the Council of the Sheffield School of Art for designers; this she has held for three years. In that period she won several awards, both local and national, by her designs, one of which was given by the Duke of Norfolk for the cup illustrated here, which this year gains the national gold medal.

The cup is modeled in wax on a shape made by Miss Mercer and is two feet in height. The other work consists of designs for a silver bell in repoussé work, and a chatelaine set, the latter especially showing a high degree of delicacy and taste.

The perfected organization of society, which necessitates invitations, acceptances, acknowledgments, appointments, letters of congratulation and condolence, has made the equipment of the library tables and of the writing desk an important duty. This, of itself, has been the occasion of the liveliest trade in silver. No article provided for it will go unsold.

## Fashions in Jewelry and Silver Articles.

A LADY'S RAMBLES AMONG THE JEWELERS.

The afternoon tea table has given rise to another department of trade, which all silversmiths recognize as important.

The eating of lobster has required on its part, several special implements. These



SOUTH KENSINGTON GOLD MEDAL DESIGN FOR A CUP.

are the crock, the pick, and the scoop with pick attached.

For a novelty that will appeal to a comparatively limited number of the people on the earth is a silver mounted check book and a silver check cutter.

The adulteration of food tempts people to grind their own pepper, to churn their own table butter; so we have silver pepper mills, and the silver churn.

For macaroni there must be macaroni forks, for asparagus asparagus tongs; sardines, Welsh rabbits, ginger, all must have their separate consideration.

The blouse, which is an evolution of the workingman's jumper, has required a belt pin in order to cement the connection between the blouse and the dress skirt in the back.

The growing scientific interest in the weather has produced barometers and thermometers designed to appeal in their mountings to the most varied tastes and pursuits.

Even our literary tastes and historical fads must have expression. At this moment details follow fast upon one another that refer to the first Napoleon and the first Empire.

The fashion of doing away with bonnet and hat strings, brought about by the high chokers the women wear, renders two hat pins necessary. On these there is no limit to the richness in material and in workmanship.

If the testimony of jewelers could be taken it would point to two things: one that fewer articles merely ornamental are bought and the other that the sale of useful articles is largely increased. The growth of luxury is seen in the demand for essential and personal articles in precious metal. Ornament finds its place on these. There is scarcely a detail that contributes to service and individual comfort that cannot find a ready sale in silver. The jeweler who can contribute a new need can find plenty of customers for it.

ELSIE BEE.

George W. Pray has removed from 9 High St. to 211 Main St., Pawtucket.

# THE BOWDEN SEAMLESS RING

IS MADE ONLY BY

## J. B. BOWDEN & Co.,

Makers of Finger Rings of every Description.

REMOVED FROM BROADWAY AND JOHN STREET,

# TO 3 MAIDEN LANE,

NEW YORK.

## W. F. Evans & Sons SOHO CLOCK FACTORY,

HANDSWORTH,  
BIRMINGHAM,  
ENGLAND.

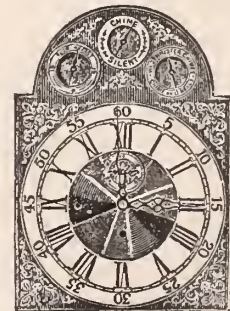

GRANDFATHER CLOCK.

Manufacturers of  
**CHURCH,  
CHIME &  
QUARTER  
CLOCKS,  
SCHOOL AND  
HOUSE CLOCKS**

With arch brass dials to chime upon  
Bells, Gongs, and Harrington's  
Patent Tubes.

ESTABLISHED 1805.



*Pairpoint*

# MANUFACTURING COMPANY.

## Gold and Silver Plate

WE ARE MAKERS OF THE  
LARGEST AND LOWEST PRICED

.....LINE OF.....

“Crown Pairpoint” China  
Rich Cut Glass,

Fine Decorated Art Goods,

.....TO BE FOUND IN THIS COUNTRY.

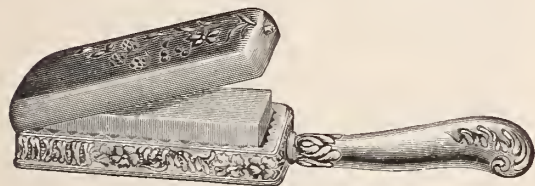

No. 2832. KNIFE SHARPENER.



No. 4908. SMOKING SET.

“WHEN IN DOUBT”

--- BUY ---

✻ PAIRPOINT GOODS.

Factories, New Bedford, Mass.



No. 3749. MATCH HOLDER.

### HOLIDAY NOVELTIES

..... OF EVERY DESCRIPTION.

**FREE**

OUR LATEST

SILVERWARE CATALOGUE No. 10, or  
CUT GLASS CATALOGUE No. 11

Will be mailed you upon receipt of address.

SALESROOMS:

NEW YORK, 46 Murray Street.

CHICAGO, 224 Wabash Avenue.

SAN FRANCISCO, 220 Sutter Street.

MONTREAL, P. Q., Temple Building.

We sell to the legitimate Jewelry and Stationery  
trade only.



NEW YORK

CITY, U.S.A

## CHOICE PAPERS

MAKERS OF

# FINE STATIONERY

For Correspondence, Wedding and Business Use, handsomely  
boxed, specially suited to the Jewelry Trade.

18 MURRAY STREET, NEW YORK.

### Watchman's Improved Time Detector

12 and 24 Different Keys with  
Safety Lock Attachments.

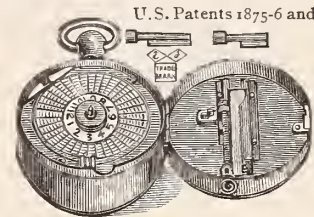

U.S. Patents 1875-6 and 7. Reissued, 1880.

This Watchman's Time Detector contains all latest improvements. The only perfect instrument in the market. It cannot be tampered with successfully. Warranted in every way.

Send for circular.

E. IMHAUSER, 206 B'way, New York,  
U. S. A.

### J. R. WOOD & SONS,

14 JOHN STREET, NEW YORK.



PLAIN SOLID GOLD RINGS.  
SEAMLESS PLAIN SOLID GOLD RINGS.  
ENGRAVED AND CHILD'S RINGS.

No Ring Stamped Different from Quality.  
Send for Catalogue and Price List.

Old Gold and Silver received and estimated on: If amount allowed  
does not give satisfaction, notify at once and will return at our ex-  
pense in same condition as received.

For **BADGES and MEDALS,**

Flag Pins, Class Pins, Class Rings  
and Special Work of all Descriptions,

SEND TO E. R. STOCKWELL, MANUF'R.,

19 John Street, New York.

# R. WALLACE & SONS MFG. CO.

## SILVERSMITHS,

WALLINGFORD, - - - - - CONN.



No. 20. FLASK.



No. 53. INK BOTTLE.  
CHASED TOP.

Trade Mark.

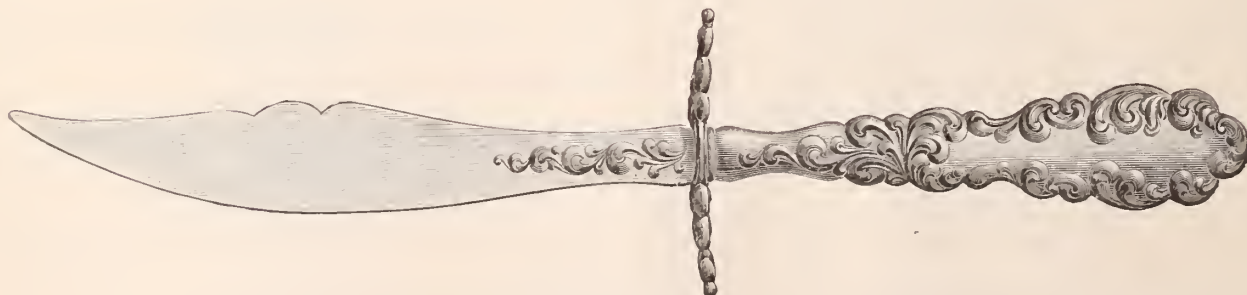

No. 39. PAPER CUTTER.

NEW YORK  
26 FIFTH AVENUE.

SAN FRANCISCO  
120 SUTTER STREET.

CHICAGO<sup>3</sup>  
86 WABASH AVENUE .

**The Dueber-Hampden Works Report a Prosperous 1894 Trade.**

CANTON, O., Dec. 24.—The Dueber-Hampden Works shut down Saturday evening for the regular holiday vacation. It was learned at the works that during the close down the regular annual inventory will be taken and the usual repairs at this time of year will be made. The notices posted in the corridors of the works state that work will be resumed Jan. 7.

It is understood that the past season, considering the depressed times, has been a remarkably successful one in both the factories, the sale of the seventeen jewel watch which Mr. Dueber first put on the market, having been so remarkable that other factories which at first attempted to discredit the enterprise, had to follow the lead of the Canton factory. Especially noteworthy has been the success of the new watch "The 400," put on the market in October. Their sale has been in excess of the company's expectations and of their ability to produce in time to fill all orders for the holiday trade. So marked has been the success of "The 400" that the line of this size will be increased for the coming season and they will be cased in various new designs, said to be the finest ever put on the market.

**Suit Against Bayse & Co. Dismissed and Balance of Stock Ordered Sold.**

SEATTLE, Wash., Dec. 24.—In the Simon Rumpf case, Judge Langley Dec. 17 signed an order dismissing the action as to J. K. Bayse and Jennie H. Klein, who are to recover their costs against the Rockford Watch Co., plaintiff. The order was made upon the basis of a stipulation entered into by the Rockford Watch Co. and the 19 intervenors, because of a showing that A. R. McOmber had fully complied with the order of court made Oct. 15 relative to purchasing the Rumpf stock and had discharged a \$5,000 promissory note at that time executed to the receiver.

The order was that receiver Arthur E. Griffin be directed to segregate from the stock of goods in his possession all goods identified as consigned to Rumpf and agreed upon between J. K. Bayse & Co. and the receiver to be consigned, and deliver them to the consignors upon payment of their pro rata share of costs accrued in the action. After the segregation the receiver was directed to sell the remainder, together with the fixtures and furniture in his possession, to McOmber, upon the following conditions: That the purchase price be \$5,000, McOmber to execute his promissory note for that amount to the receiver, payable in 90 days, interest at 10 per cent., that the stock be sold at retail at public or private sale, under the direction of the receiver, the daily proceeds to be paid the receiver, from which he is to pay the rent, insurance, lights, commissions of auctioneer, advertising and other expenses, the balance to be applied on the note; the property when the note shall have been fully paid to vest absolutely in McOmber.

McOmber is to have the right to sell the goods, provided the terms be not substantially less than the market price, except upon consent of the receiver, and to have the further right to remove the stock to some other store in the business portion of the city.

**Movement Among the Connecticut Clock and Silver Plate Factories.**

NEW HAVEN, Conn., Dec. 29.—The Thomaston clock and watch shops were shut down for repairs all this week. The rolling mill ran as usual, except Christmas day.

All the factories in Wallingford have been run to their fullest capacity to fill their orders for the last three months. They all expect a good trade in the Spring and base these expectations on the comparatively small stocks in the hands of the dealers as reported by their traveling men. The Va-

entine, Linsley Co., Wallingford, are moving into their new shop on Bull Ave.

In some of the Meriden factories the cheering news is out that business is so rushing that except on Christmas and New Year's day the full force will be kept at work all Winter. The J. D. Bergen Co. are so driven with work that they shut down only on Christmas, and the Meriden Cutlery shop will keep working right through the Winter, only closing for the two holidays. The Meriden Bronze shop is closed for two weeks, while the Chapman Mfg. Co., outside of one department, shut down to-day for two weeks. The Wilcox Silver Plate Co. and Miller Bros. will not shut down until New Year's, when the vacation will probably be two weeks at each place. The E. Miller Co. closed for only one week. The Meriden Silver Plate Co. have shut down for two or three weeks. The main department of C. Rogers & Bros. quit work Dec. 22d for two weeks.

**Death of Charles Lockwood, the Faithful Messenger.**

NEW HAVEN, Conn., Dec. 27.—Charles Lockwood, formerly well known as a most faithful and efficient messenger between New Haven and New York, chiefly in the employ of prominent jewelry firms, died this week in the insane asylum in Middletown. He met with a painful experience in Stamford about four years ago. He made his escape from an institution for the insane in New York, one day in the middle of Winter, and started to walk back to New Haven. He had reached Stamford and went to sleep in a box car. The night was bitter cold and his feet were frozen.

The jewelers of New Haven raised a fund for his care in New York and he was sent back there for treatment for his feet and after a time was sent to Middletown, where he remained until his death. The fund raised at the time was not consumed, and the balance will be used toward his burial. His widow is now residing in Boston.

**DON'T LET A GOOD THING ESCAPE YOU.**

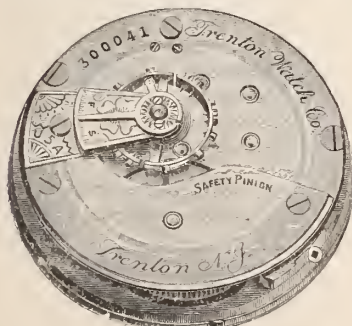

18 SIZE, 7 JEWELS.

THE REDUCED PRICE ON ALL GRADES OF TRENTON MOVEMENTS PLACES THEM WITHIN REACH OF EVERYBODY AND SURPASSES ALL COMPETITION. THEIR EVER INCREASING POPULARITY IS DUE TO THE UNIVERSAL SATISFACTION THEY ARE GIVING. THOUGH LOW IN PRICE, THEY ARE HIGH IN QUALITY.

SEND FOR ILLUSTRATED PRICE LIST, AND ORDER FROM YOUR JOBBER.



16 SIZE, 16 JEWELS.

**TRENTON WATCH CO.,**  
TRENTON, N. J.

# A MODEL FACTORY BUILDING.

THE KENT & STANLEY CO.'S MAMMOTH NEW STRUCTURE, THE FINEST OF ITS KIND IN THE WORLD.

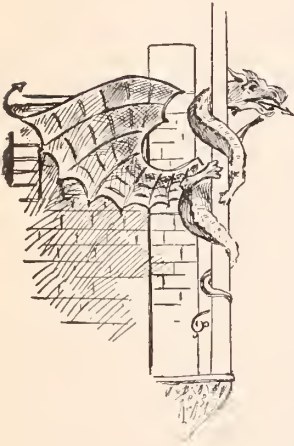

**P**ROMINENT among the many handsome factory buildings for which Providence is noted is the handsome structure built and occupied by the Kent & Stanley Co., on the Square bounded by Sabin, Aborn, Beverly and Mason Sts., in that city. The property which it occupies was the location of the old-time popular skating rink, destroyed by fire last year. Mr. Edwin F. Kent, recognizing the advantages of the site, on his own responsibility purchased the property after the fire, though at that time the building occupied by the Kent & Stanley Co., at Eddy and Fountain Sts., was generally looked upon as a model factory, excellently planned and perfectly equipped.

Mr. Kent's foresight in the matter of the purchase of the new site was soon endorsed by his partners. Its proximity to the new railroad depot, which will be one of, if indeed not the finest, in the country is a guarantee of increasing values in that section of the city, while the increased shop room was something rendered imperative by the firm's constantly increasing business.

Work on the new structure which is depicted in one of the illustrations in this article, was begun on November 1, 1893, and October 1, 1894, the company was operating in its new quarters.

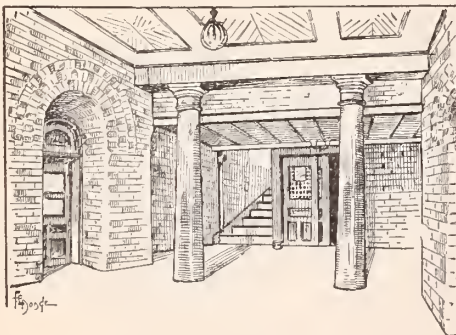

MAIN ENTRANCE ON SABIN ST.

The readers of the CIRCULAR can gather an idea of the immensity of the structure when it is borne in mind that it occupies an

acre of ground, rises seven stories above the foundation, has over 250,000 square feet of floor space, about 1,200 windows and required over five million bricks in its construction. While nearly all available space has already been leased, firms seeking modern quarters will do well to bear in mind that rentals are figured on a basis of 30 cents per square foot per annum, including power, steam heat water and elevator service.

The ground plan and character of the plot is excellently suited for the purpose to which it has been put. The L shaped formation gives it a frontage of 276 feet on Mason St., 221 feet on Aborn St., 106 feet on Sabin St., and 123 feet on Beverly St. A light well 40x200 feet extends from roof to basement in the main structure



THE KENT & STANLEY CO.'S BUILDING.

which with the additional advantage of four street frontages makes that great desideratum, good light, an assured fact for each tenant.

Red brick with brownstone trimmings was the material used for the walls, which rest on particularly solid foundations. At either corner on the Sabin St. facade are two handsome flag staffs held in place by artistic creations in wrought iron of dragons, one of which is incorporated in the initial letter beginning this article. Flags floating from these staffs bear, one, the company's trade mark on a white field and the other the national colors.

The two entrances to the building are well worthy of attention. Each shows a granite arch, while within enameled bricks of a light bluff tint please the eye and present an imperishable surface.

## THE KENT & STANLEY CO.

Our illustration shows the Sabin St. entrance with the handsome wrought iron elevator in the back ground, and two beautifully silvered supporting columns. The other entrance on Beverly St. is practically the same. Marble slabs for the names of the tenants is another feature not usually found in a factory building, and rapid running passenger elevators at either entrance afford quick access to, or egress from any floor. In the driveway running through from Sabin to Mason Sts., are two commodious freight elevators.

Floorings throughout are of maple, each floor being nearly an acre in area. The supporting columns are of iron, rising thirteen feet to the ceilings. Grinnell sprinklers and all other modern factory conveniences make the building a perfect one, whether from the view of the tenant, the insurance or the factory inspectors. Over 3,500 hands can find accommodation within its walls. Power and light are furnished by the company's private electric plant, one of the finest in the country.

The offices of the Kent & Stanley Co. are fitted up in oak, in the best taste, and pre-

sent an exceedingly attractive and handsome appearance. They occupy practically the whole of the Sabin St. wing on the sixth floor. Our illustration shows a view of the general office; adjoining it is the private office of Mr. E. F. Kent, which also connects with the director's suite.

The Kent & Stanley Co.'s shop, ever known as a model one, is in the new building better than ever. In one of the illustrations accompanying this article is shown a corner in the silver shop, a line in which the company is winning rapid recognition, and of which some of the productions, notably yachting trophies, have already been the subject of extended mention in the CIRCULAR.

A pioneer in selling its goods directly to the retail trade, the company, through its ten traveling salesmen and New York, Boston, Philadelphia and San Francisco offices offers a wide and varied line of goods. Some idea of its scope can be gathered from the fact that among them are

**THE KENT & STANLEY CO.**

One-tenth and one-quarter Gold Seamless Wire Chains; Gents' Rolled Plate Vests, all Seamless Wire, 1, 2, 3, Strand Curbs; Dickens, Trace, Rope, Single Curb, Boston

**THE KENT & STANLEY CO.**

its predecessor, if that is possible. The business of the present Kent & Stanley Co. was first established in 1873 under the style of William H. Robinson & Co.,

**THE KENT & STANLEY CO.**

surviving partners, Edwin F. Kent and Arthur W. Stanley, under the old firm name. In 1887 these gentlemen purchased Mrs. Robinson's interest and continued under the style of Kent & Stanley. Under the new impetus, business during the two following years was doubled, but on Feb. 19, 1888, another fire once more interrupted operations by burning the factory entirely to the ground. Another shop was immediately found by Mr. Kent, and by noon of the day following the fire new machinery was already being put in position at the new shop, an instance of his indomitable will and prompt action in an emergency to which is due in a large measure the firm's success and high position to-day.

A lease of the ground on which the burned building had stood was quickly secured, and without the least unnecessary delay, Kent & Stanley began the erection of a building suitable to the needs of jewelry manufacturers which, when completed, ranked among the best factory buildings in the city. The firm took up its quarters in it and continued with increasing success. In February 1891, it was incorporated, under the title of the Kent & Stanley Co., being capitalized at \$300,000, represented in real property, and with charter rights for half a million. In November, 1893, the constantly increasing business necessitated larger quarters and the balance of the treasury stock was issued. In July, 1894, this additional stock had been issued, paid for in cash and invested in the new plant, which forms the subject of this article. It represents an investment of about \$350,000, and the total capital and surplus of the company in-



VIEW OF GENERAL OFFICE.

and Fancy Links; Red Gold and Platinum Links in all styles; Ladies' Lorgnette, Neck Vest and Victoria Chains; 1,500 styles Gold, Silver and Plated Locketts and charms; White Stone Lace Pins and Brooches; Hair Ornaments; Chain Bracelets, Plate and Sterling Silver; Hat, Hair, Stick, Scarf and Bib Pins; Plated Sword Corsage Pins; Bracelet and Eye-Glass Chains.

In Sterling Silver Novelties, all warranted Sterling Silver are: Garters, Collarettes, Pocket Combs, Tie Holders; Belts with Silver, Pearl and Tortoise Shell Buckles, Paper Cutters and Weights, Match and Stamp Boxes, Trays, Letter Clips, Letter Openers, Book Marks, Prayer Book Marks, Thermometers and Calendars, Satchel Tags, Hat Marks, Coat Hangers, Souvenir Spoons, Umbrella Claps, Pearl Teething Rings and Rattles, Glove Hooks, Button Hooks, Glove Stretchers, and Hat Buckles, Hair Pins in Celluloid, Real Tortoise Shell, Silver Mounted; Tooth Brushes, Shoe Horns and Letter Seals, Mirrors, Game Counters, Cigarette Cases, Sword Corsage Pins, Key Ring Chains, Bonbon Spoons, Pocket Knives, Scissors, Razors, Manicure Articles, Gold and Silver Mounted Suspenders, Novelties in Leather Card Cases, memorandum Books etc; Stag Handle Cutlery Novelties, Corkscrews and many others.

The company issued last year one of the finest illustrated catalogues ever put out by a jewelry house and another is now in preparation which will be even better than

at 25 Calendar St. and the output consisted of chains. In 1882 Mr. Edwin F. Kent became a member of the firm and at once took an active interest in its welfare. In 1884 occurred the disastrous fire still remembered by the citizens of Providence, in

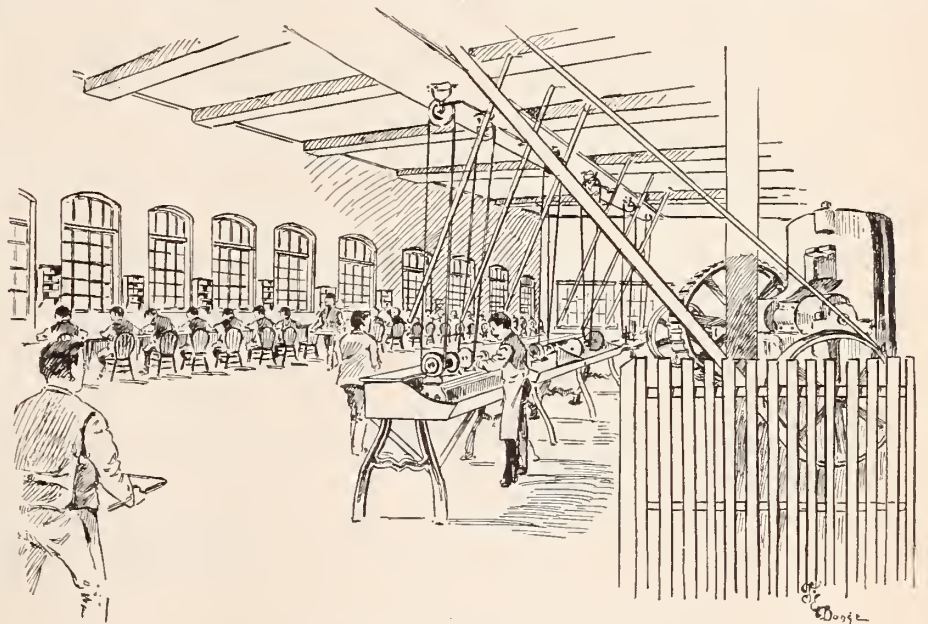

A CORNER IN THE SILVER SHOP.

which the factory was destroyed. New quarters were found at 7 Eddy St., and operations were again resumed. In 1885 Mr. Robinson died, and for nearly two years the business was conducted by the

vested in business is \$650,000. Its officers are: president, A. W. Stanley; treasurer, E. F. Kent; vice-president, J. S. Ingalls; secretary, J. D. Warren. George R. Clarke is superintende it and designer.

### The United States Optical Co. Closed Under a Mortgage.

DETROIT, Mich., Dec. 28.—The United States Optical Co. were last week closed by William C. Hegge, trustee for certain creditors on a mortgage given last July. The factory is located at 78, 80 Miami Ave. and the firm have been in business about three years. They are at present busy taking an inventory of stock and expect to finish the same in another week when it will be offered for sale in bulk. Mr. Hegge is in charge of the inventory.

Mr. Marx, secretary and treasurer of the concern, says no schedule has yet been made of their assets and liabilities but he thinks they will come out even. The stock is worth considerable more than the mortgage. He says the firm did a good business the first part of the year but that lately the sales have been falling off and they have been unable to meet the obligations of certain Detroit creditors. Outside firms have also recently received judgments against the firm and the trustee made the above move in order to protect the holders of the mortgage.

This instrument was given on July 14, 1894, and amounted to \$14,996.64. Those who were secured were the following: L. B. Colwell, Oscar B. Marx, Frank A. Rasch, August Rasch, Oscar E. Rasch, Eugene Deimel, S. G. Miner, J. J. Rankin, Charles Ortman. It is not known whether the firm will resume or not.

### Bay City, Mich., to Have an English Hall Clock Factory.

DETROIT, Mich., Dec. 28.—Dispatches to Detroit papers state that Bay City will shortly have a new industry in the shape of an English hall clock factory, to be operated by the Bay City Hall Clock Co. F. W. Wheeler, ship builder, and Frank H. Shearer, jeweler, are the principal stockholders.

The cases will be made in Bay City and the movements imported direct from Elliott, the English clockmaker. There is

but one other exclusive hall clock concern in the country.

### The Store of G. Howard Werntz Closed on an Execution.

LANCASTER, Pa., Dec. 28.—Late yesterday afternoon Mrs. Rose C. Werntz issued an execution for \$4,240 against G. Howard Werntz, jeweler, 116 N. Queen St., this city, a levy being immediately made and the store closed. The execution creditor is Mr. Werntz's wife. The cause of the failure is due to Mr. Werntz being involved with the Philadelphia Optical & Watch Co., a bankrupt corporation.

Arthur H. Williams' Sons obtained judgment against the optical company, attaching with other property the claim against Mr. Werntz amounting to \$400. Judgment on this claim would have been obtained against Mr. Werntz to-day and in order to protect his wife, whose money is in the business, Mr. Werntz confessed judgment to her.

### Jeweler F. A. Knowlton Wants \$20,000 For His Lease.

WORCESTER, Mass., Dec. 28.—Some time ago the State Mutual Life Assurance Co., of this city, purchased the property known as Grand Army Hall block, corner of Main and Walnut Sts., and immediately began excavations in the rear for an \$800,000 block. Frank A. Knowlton, one of the most prominent jewelers in the city, occupies two store rooms in the old block and his lease does not expire until Jan. 1, 1897. The State Mutual people have compromised with the other tenants who have vacated their rooms, but the company and Mr. Knowlton have not as yet reached any agreement and the building of the new block, on this account, may be delayed.

Knowlton and A. George Bullock, president of the State Mutual, have had one consultation regarding the matter but came to no understanding and it was stated Thursday that Mr. Knowlton wants \$20,000 to move. When Mr. Knowlton was seen by a representative of THE CIRCULAR regarding the

matter he said that he had not made any definite offer to the State Mutual people, and that he wants only what is right. He said, however, that he has had a good business this year, and that it will not be to his advantage to move unless he is paid more than \$20,000. He says, also, that he is perfectly willing to remain where he is, unless he can get what his business is worth.

The State Mutual people believe that Mr. Knowlton is trying to take advantage of their position. It is thought that if Mr. Knowlton does not lower his price, the company will go on with their building, leaving the corner which he occupies until his lease expires, when they will finish their building.

### Death of a Pioneer Milwaukee Watchmaker.

MILWAUKEE, Wis., Dec. 26.—Joseph A. Sidler, who a number of years ago conducted a prosperous watchmaking and jewelry business on Chestnut St., died yesterday at his residence, 914 Cedar St. He was one of the early day business men of Milwaukee, though during the last 10 years he had lived in retirement on account of poor health.

The deceased was born in Kuesswacht, Switzerland, May 26, 1826. In 1852 he came to the United States, and in 1858 to Milwaukee. He was married in 1860 and soon after that established himself in the watchmaking trade, making his headquarters on Chestnut St. His wife and five children survive him.

Thieves recently broke into the jewelry establishment of Moore & Moffett, Oakland, Ill. Night watchman Hamm was aroused and shots were interchanged, but the men escaped.

Three men swindled Cortland, N. Y., people out of about \$50 last week by making a house to house canvass repairing clocks and jewelry. They skipped out with considerable plunder. They operated the same swindle at Ithaca and were captured at Binghamton.

# ORANGE SPOONS

Do you want a line of ORANGE SPOONS or ORANGE SETS which will give credit to your store?



RIALTO ORANGE SPOON.

HAVE you seen our ORANGE SPOONS and ORANGE SETS? Send for special prices.

OUR ORANGE SETS are put up in fine satin lined cases. Jewelers everywhere say, "The best line of goods made."



WESSELL ORANGE KNIFE.

Our New York Salesroom, 2 MAIDEN LANE, Second Door from Broadway, carries a full line of

STERLING SILVER HOLLOW WARE, NOVELTIES AND PLATED WARE.

THE HOLMES & EDWARDS SILVER CO.,

BRIDGEPORT, CONN.

### The Death of William Turner Gale.

On Christmas night there passed away at his home, 125 W. 123d St., New York, William T. Gale, who had been actively engaged in the jewelry trade for about 45 years, nearly 20 of which were passed in the employ of Tiffany & Co. The deceased was the son of a clergyman of Rockport, Mass., and one of eight children. The limited means of his father prompted a wealthy uncle, Daniel Safford, to invite William to live with him in Boston, and there complete his education. He was graduated from the Latin School in 1853 at the age of 17 years, and began his business career in the employ of the old-time jewelry firm of Palmer & Bachelder, Boston. He remained with this firm and their successors about 20 years, and in 1862 embarked in business in Boston with James P. Snow, now of Snow & Westcott, New York, under the firm name of Gale, Snow & Co. After about five years, this partnership was dissolved, and in 1877 he entered the employ of Tiffany & Co., and remained with the house until his death.

Mr. Gale was one of the salesmen selected by Tiffany & Co. to preside at the firm's exhibition in the Tiffany Pavilion at the Paris Exposition of 1889, and in recent years he was connected with the diamond department of the Union Square store. He leaves a widow, two sons and a daughter. He was in his 57th year. The funeral

services were held at his late residence, Dec. 28th, the interment being private.

Mr. Gale was a man of fine presence, courteous manners, and apparently robust physique until about a year ago, when he began to be troubled with what appeared to be Bright's disease; other complications set in, and on Sept. 27 he was confined to his bed, his disease having developed into hasty consumption.

### Further Details of the Assignment of Charles Veicht.

MILWAUKEE, Wis., Dec. 27.—As reported in last week's CIRCULAR, Charles Veicht, dealer in jewelry and loan agent, 306 Grand Ave., has made an assignment to Matthew Killilea. The sureties are John Mueller and Frederick C. Gow. They gave bonds to the amount of \$35,000. Veicht, it is said, has been doing a large business. He came to Milwaukee from Indianapolis.

The insolvent said to a reporter that he had been forced to make the assignment by the knowledge that his stock was to be attached. "I made the assignment," he said, "at ten minutes past 12, and the sheriff arrived with attachment papers fifteen minutes later. I paid notes Saturday of \$900 and \$718, and that certainly doesn't look as if I intended to defraud any creditors. This attachment was sought by a New York firm, to whom I owe bills, which are not due until March and

May. I expect to have my affairs straightened out soon and pay every creditor dollar for dollar."

### Sweeney & Fredericks Robbed During the Holiday Rush.

HOUSTON, Tex., Dec. 27.—It has leaked out that several valuable diamonds were stolen a few days ago from Sweeney & Fredericks' jewelry store, corner of Main St. and Congress Ave. It appears that the jewels were stolen from the large show window by some one who sneaked inside during a rush of holiday business, and the interior windows being opened, grabbed the goods and escaped unnoticed.

The goods were not missed till the clerk went to lock them in the safe for the night. Their value is estimated at \$2,000.

### Burglars Work in the Rear While Business Was Brisk in Front.

COUNCIL BLUFFS, Ia., Dec. 26.—Burglars last night robbed N. P. Conant's jewelry store, 414 Broadway, of 90 watches and 100 solid gold rings. While business was going on in the front of the store, the thieves cut a pane of glass from the rear door and took everything in sight. No one saw them at work.

Jewelry was scattered all around the rear of the premises, showing the haste of the burglars. The loss is estimated at over \$1,000.

# JONES & WOODLAND,

*Late of the Firm of*  
**LARTER, ELCOX & Co.**

On January 1, 1895, we started up our New Factory and Office  
at 49 Chestnut Street (Krementz Building), Newark, N. J.

OUR LINE will comprise Children's, Ladies' and Gentlemen's PLAIN AND FANCY RINGS. A large assortment of IMPROVED SPRING BACK STUDS in new designs; LINK BUTTONS, STONE SEALS, etc.

The Superintendent of our Factory is Wm. C. Woodland, for 30 years Superintendent for the old firm.

WILLIAM H. JONES.  
THEODORE M. WOODLAND.

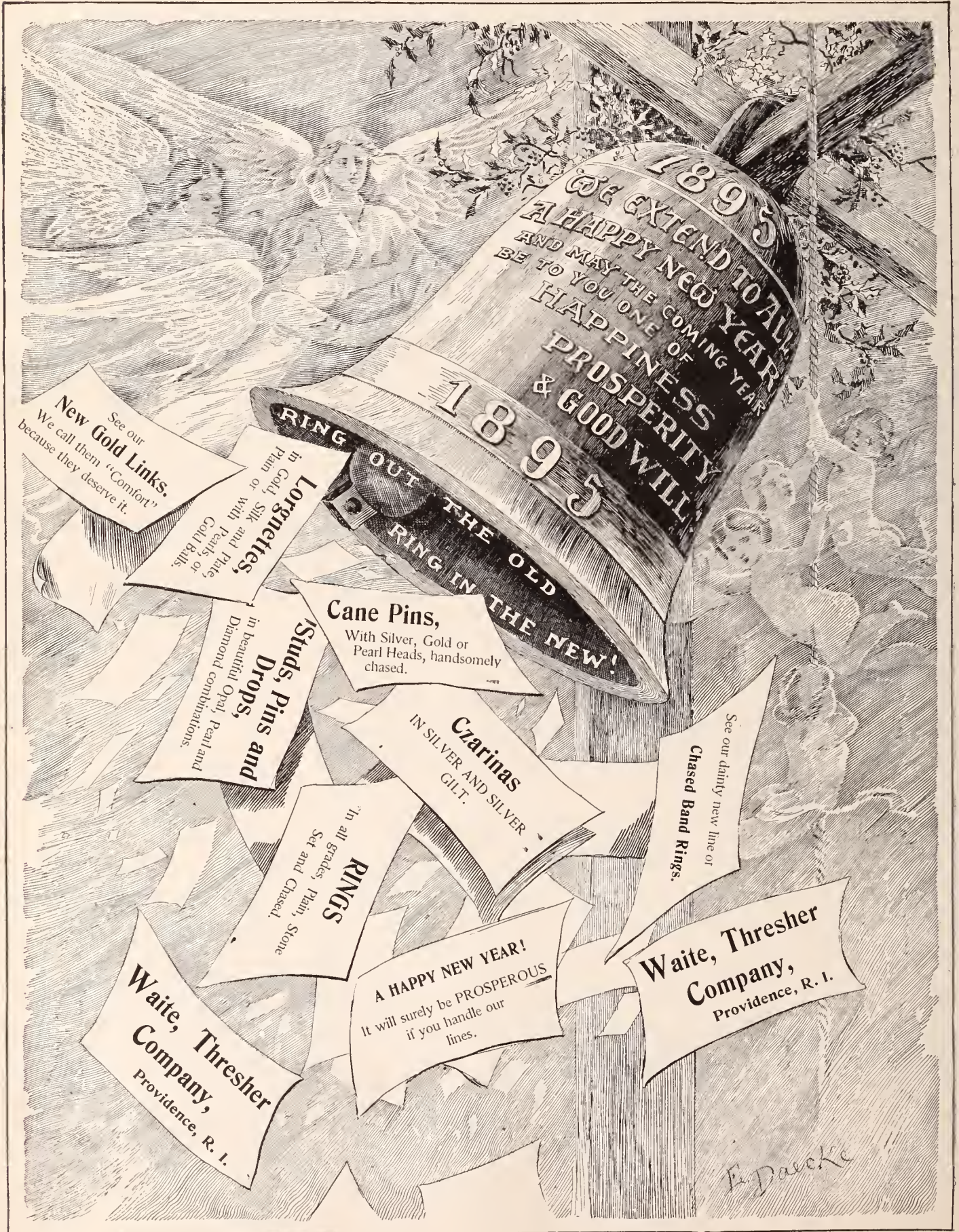

1895  
 WE EXTEND TO ALL  
 A HAPPY NEW YEAR  
 AND MAY THE COMING YEAR  
 BE TO YOU ONE OF  
 HAPPINESS  
 & GOOD WILL  
 1895

See our  
**New Gold Links.**  
 We call them "Comfort"  
 because they deserve it.

**Lorinettes,**  
 in Gold, Silk and Pines,  
 plain or with Pearls, or  
 Gold Balls.

**Studs, Pins and  
 Drops,**  
 in beautiful Opal, Pearl and  
 Diamond combinations.

**Cane Pins,**  
 With Silver, Gold or  
 Pearl Heads, handsomely  
 chased.

**Czarinas**  
 IN SILVER AND SILVER  
 GILT.

See our dainty new line of  
**Chased Band Rings.**

In all grades, plain, Stone  
 Set and Chased.  
**RINGS**

**Waite, Thresher  
 Company,**  
 Providence, R. I.

**A HAPPY NEW YEAR!**  
 It will surely be PROSPEROUS  
 if you handle our  
 lines.

**Waite, Thresher  
 Company,**  
 Providence, R. I.

*E. Daercke*



**Two New Metal Working Corporations in Connecticut.**

HARTFORD, Conn., Dec. 28.—A certificate of organization was filed with the Secretary of State to-day, by the Eagle Sterling Co. of Glastonbury, manufacturers and dealers in all kinds of goods and wares made wholly or in part of silver, britannia, brass, copper or other material, and all kinds of cutlery and household goods, useful and ornamental, of glass, metal, or other substance.

The capital stock of the company is \$20,000, divided into 200 shares of the par value of \$100 each. Of the capital stock, \$8,000 has been paid in cash. The subscribers to the stock are S. C. Hardin, 40 shares; S. C. Hardin, trustee, 30 shares; P. H. Goodrich, 40 shares; E. S. Stevens, 40 shares; S. P. Turner, 40 shares. The above are residents of Glastonbury and Alderman W. H. Watrous, of this city, subscribes for 10 shares of the stock.

The Naugatuck Mfg. Co. have been organized at Naugatuck to develop any and all processes for the working of metals. The capital stock of the company is \$10,000, divided into 400 shares. The capital stock has all been paid in.

**Death of a Well Known Silversmith.**

WALLINGFORD, Conn., Dec. 28.—Isadore Appletree, one of the best silversmiths in this vicinity, died at his home here at 10 o'clock this morning. He had been suffering from a complication of diseases.

He came to this country from England four years ago, and went to work for Simpson, Hall, Miller & Co., where he was employed for a year. Then he went into business for himself, manufacturing pocket flasks principally. These he disposed of to all the leading dealers. He had completed a large new factory, which he was about to occupy. Mr. Appletree was 54, and leaves a widow and one daughter.

**Jeweler Van Laeys Wants \$5,000 for Being Called a Thief.**

TOPEKA, Kan., Dec. 28.—Alphonse Van Laeys, a jeweler at 23 Kansas Ave., North Topeka, has filed suit in the District Court against one Holthoise asking for \$5,000 damages. The petition states that the plaintiff has always sustained a good name and character and did a good business until defendant made derogatory remarks about him. Holthoise, defendant, had said that plaintiff had robbed him of everything he owned and stole his watch. On another occasion he openly called the plaintiff a thief and a robber.

The plaintiff states that defendant is now a non-resident of the State, living in Nebraska.

The store of Wm. Griffith, Cleveland, O., has been attached, and the sheriff is in possession.

**Bertha Ehrlich Assigns Her Business After 30 Years' Existence.**

Bertha Ehrlich, a retail dealer in optical goods, cutlery and jewelry, at 3 Astor House, New York, made an assignment Thursday to Isaac Hirsch, giving preferences to Leopold Gusthal, for \$1,872.49 for money loaned and to Isaac Hirsch, \$1,000, on a promissory note.

The failure is said to be due to poor business. Louis S. Phillips, the attorney for Mrs. Ehrlich, told a CIRCULAR reporter that the business had been running behind for about two years and as the accounts were all coming due, and the Fall business had not been sufficient to meet these accounts, an assignment was deemed necessary. A meeting of the creditors has been called for Friday afternoon, at Mr. Phillip's office, 35 Broadway. A proposition for an extension, he said, will be made at this meeting, and if this is not agreeable to the creditors, instructions from them as to what course they wish the assignee to pursue will be asked for. As the rent of the store is \$100 per week Mr. Phillips said he desired matters to be settled quickly and avoid unnecessary expense.

The attorney also stated that Mrs. Ehrlich had also assigned over her property at Long Branch for the benefit of the creditors. This consists of a house and lot, valued at \$7,500, mortgaged to the Mutual Life Insurance Co. for \$4,000 and to two preferred creditors for \$2,840, and a lot worth \$750, mortgaged to the Irving National Bank for \$400. The schedules filed Thursday show the assets outside the real estate to be nominally \$7,312.11 and actually worth \$3,193.63. The liabilities amount to \$10,221.37 of which \$2,872.49 is to preferred creditors and the remaining \$7,348.88 to merchandise creditors.

The principal creditors are: Irving National Bank, \$500; Empire Knife Co., \$112; Winsted Optical Co., \$461; Goldsmith Mfg. Co., \$657; B. Kahn & Son, \$355; Lowey & Bovet, \$152; Jos. Friedlander & Bros. \$110; M. Frank & Co., \$753; Albro & Co., \$125; Kent & Stanley Co., \$125; Hayden Mfg. Co. \$102; Shaef & Schmidt, \$146; J. Ehrlich, \$1,200; E. Waterman & Co., \$150; and E. S. Johnson & Co., \$150.

The business owned by Mrs. Ehrlich was founded by her husband, Jacob Ehrlich who still manages it, over 30 years ago. He started as a dealer in optical goods at 3 Astor House, and in 1885 bought out the cutlery business conducted in the same store. About six years ago he turned the business over to his wife and since then has run it for her.

**The Sheriff in Possession of John Klipper's Business.**

Deputy Sheriff Mulvauey Wednesday took possession of the place of business of John Klipper, wholesale dealer in jewelry and optical goods, 41 Maiden Lane, New York, on executions for \$6,288. He confessed judgments to Joseph S. Klipper, for

\$4,604.98; Morris Klipper, \$949.09; Leon Hirsch, \$439.29. Another judgment for \$276.20 was entered Thursday in favor of Hipp Didisheim & Bros.

John Klipper came to this city from New Orleans, La. He originally started in business in New York city in 1887, as Gottlieb & Klipper, but the next year, Oct. 1, 1888, he went to New Orleans and succeeded to the jewelry and cutlery business carried on by his mother, Sarah Klipper, in that city. His father, Jos. Klipper, previously failed in St. Louis. In June, 1892, John Klipper moved his business from New Orleans to 436 Broadway, New York, where he dealt in cutlery and sporting goods and jewelry. In March, 1893, he moved to his present location in the Knapp building, 41 Maiden Lane, and became a jobber in optical goods and jewelry.

The jewelry store of D. P. Perkins, Chappell Hill, Tex., was entered by burglars last week and about \$700 worth of jewelry stolen. An unsuccessful attempt was made to blow open the safe. The safe was injured in such a manner that the proprietor could not open it.

S  
P  
E  
N  
C  
E  
R  
  
O  
P  
T  
I  
C  
A  
L  
  
M  
F  
G  
  
C  
O

SAID GRANDMAMMA TO GRANDPAPA,  
SLEEPING AT HIM WITH FURROWED BROW  
ENOUGH OF LIFE I HAVE NOT SEEN,  
NOR CAN I SPARE MY EYE-SIGHT NOW.  
COULD I REGAIN MY SIGHT OF YOUTH,  
I WOULD FOR A FEW SHORT YEARS TO COME,  
RICHES, OFFERED, WOULD FIND ME LOTH,  
  
ON PARTING FROM MY TREASURE WON,  
PERHAPS I CAN YOUR WANTS RELIEVE,  
TO TRY WILL BE MY CHIEF DESIRE  
IN BRINGING TO YOU SUCH RELIEF AND  
COMFORT, AS I CAN ACQUIRE,  
AND GRANDPA QUICKLY DONNED HIS HAT,  
LAUGHING CONFIDENTLY ALL THE WHILE,  
  
MAKING HASTE, WHILE GRANDMA SAT  
FORGETTING ALL, SAVE THAT HIS SMILE  
GAVE HER GOOD CHEER, FOR SINCE THAT  
TIME HER  
  
CONSTANT THOUGHT IS ONE OF THANKS  
OVER ALL OTHERS FOR GLASSES GOLD, MADE  
BY THE SPENCER OPTICAL MFG. CO.

### Preparations for the Annual Meeting of the Jewelers' League.

The 18th annual meeting of the full membership of the Jewelers' League of New York, will be held in Masonic Hall, 6th Ave. and 23d St., New York, on Tuesday evening, Jan. 15, 1895. The annual reports of officers and of the executive committee will be presented, and an election held for president for one year, two vice-presidents (known as 3d and 4th), for two years, three members of the executive committee for the term of two years, one member of the executive committee for one year, and three members of the advisory board, to serve two years.

The following are the nominations for officers to be elected at this annual meeting:

For president, Henry Hayes; 3rd vice-president, Jos. B. Bowden; 4th vice-president, Wm. Bardel; executive committee for 2 years, D. Untermeyer, G. M. Van Deventer and J. W. Beacham; executive committee for 1 year, O. G. Fessenden; advisory committee for 2 years, Geo. W. Parks, Chas. L. White and J. W. Steele.

The following amendment is sent out to the membership with the approval of the executive committee:

#### ARTICLE III., SECTION 1. OFFICERS AND ELECTIONS.

Its officers shall consist of a president, four vice-presidents, respectively designated as first, second, third and fourth, and an executive committee consisting of the officers ex officio and six other members, all of whom shall be elected by ballot, as hereinafter provided, from members engaged in the jewelry or kindred trades, and shall continue in office during their respective terms and until their successors shall be elected and qualify, except such as shall be removed, as hereinafter provided.

The following amendments are sent out to the membership with the disapproval of the Executive Committee:

#### Add to ARTICLE III., Section 1.

There shall also be an Advisory Board, consisting of twelve members who shall be elected by ballot as hereinafter provided for from members of Sections A and B.

Such Advisory Board shall hold office for one (1) year and until their successors shall be elected.

#### Add to Amendment on Nominating Committee.

The Nominating Committee shall make nominations for but six (6) members of the Advisory Board. The other six and all additional nominations for the Advisory Board shall be made at the Annual Meeting.

#### Strike out Section 4, ARTICLE III., and insert:

The First Advisory Board of the twelve members shall be elected at the 1895 Annual Meeting.

#### Strike out Section 2, ARTICLE IV.

Make Section 3 Section 2,

Make Section 4 Section 3.

Make Section 5 Section 4.

Insert Section 5, Article 4.

It shall be the duty of the Advisory Board to cooperate with the Executive Committee in all matters concerning the good and welfare of the League. The Advisory Board shall, from time to time, examine the books, accounts moneys and property of the League, and at least once a year shall cause a thorough examination to be made of the affairs of the League. This examination shall be made by an expert accountant under the direction of the Advisory Board. The Executive Committee shall make suitable provision for the payment of such accountant's services. It shall be the duty of the Advisory Board to report upon the books, accounts, vouchers of the treasurer, and on all securities, investments and property of the League in the keeping of the Executive Committee.

These reports shall be made at the First Annual Meeting succeeding the election of each Board or at any special meeting called for the purpose.

#### ARTICLE IX., insert:

SEC. 2.—The Executive Committee shall call a special meeting of the League at any time upon the application, in writing, of seven members of the Advisory Board for the purpose of receiving and acting upon any report and recommendations of the Advisory Board.

#### Make Section 2 Section 3.

### It Was Insanity Led Elmer Foster to Suicide.

CHICAGO, Ill., Dec. 29.—In speaking of the recent sad suicide of Manager Elmer Foster, of E. V. Roddin & Co., which was attributed at the time to overwork and exhaustion, Mr. Roddin says the cause was not as stated, but that the young man's death was brought about by a predisposition to insanity which he inherited from his father, who committed suicide shortly after his son's birth. "I learn that if he had experienced adversity he would have committed the deed long ago," said Mr. Roddin.

J. W. Atwell, for years with E. V. Roddin & Co., succeeds to the position of manager made vacant by Mr. Foster's death.

### Cass County, Neb., Gets a Verdict Against the Seth Thomas Clock Co.

PLATTSMOUTH, Neb., Dec. 25.—Judge Chapman has decided the suit of the Seth Thomas Clock Co. against Cass county, wherein the clock company sued for some \$900 as payment for the court house clock, in the county's favor.

The court held that the county had already paid for the clock to the company's authorized agent, C. M. Wickersham, and if the latter before absconding, had failed to settle with the clock company, it was not the county's affair. The clock company will take an appeal to the Supreme Court.

I am well pleased with THE CIRCULAR and no man in this business can afford to be without it.

H. A. ANSTEAD, Massena, N. Y.

## DIAMONDS.

# Wm. S. Hedges & Co.,

## Importers of Diamonds,

And Manufacturers of DIAMOND JEWELRY.

170 Broadway, New York.

22 Holborn Viaduct, London.

## Alfred H. Smith & Co.,

IMPORTERS

# DIAMONDS

AND

PRECIOUS STONES,

82 BROADWAY, COR. JOHN STREET,

NEW YORK.

83 Holborn Viaduct, London, E. C.

## R. A. KIPLING,

### Precious Stones

AND Fancy Goods

Bought and Sold on Commission.

19 RUE DROUOT,

PARIS, FRANCE.

### ONE YEAR'S SUBSCRIPTION

—TO—

## The Jewelers' Circular

—At \$2.50,—

Entitles the subscriber to a copy of "WORKSHOP NOTES" free, a 200 page book, bound in cloth, containing a fund of information for the workshop that can be found in no other work.

**Last Week's Arrivals.**

*THE CIRCULAR has perfected arrangements for obtaining the names and hotel addresses of all the latest buyers visiting New York, and each day posts in its office, 189 Broadway, a bulletin which every member of the trade is cordially invited to copy*

The following out-of-town dealers were registered in New York during the past week: A. B. Harwood, Boston, Mass., Imperail H.; Jos. Eisenback, San Francisco, Cal., Marlborough H.; C. C. Shaver, Utica, N. Y., B'way Central H.; P. H. Ives, Meriden, Conn., Murray Hill H.; E. Ellerman, Philadelphia, Pa., Astor House; H. Lowens' ein, St. Louis, Mo., B'way Central H.; L. E. Kirstein, Rochester, N. Y., Coleman House; E. G. Acheson, Monongahela, Pa., Astor House; S. M. Sigler, Cleveland, O., Astor House; W. S. Rowe, New Haven, Conn.; Grand Union H.

**The New Firm of Eckfeldt, Ackley & Woodland.**

Beginning Jan. 1st, Eckfeldt, Ackley & Woodland engage in the manufacture of fine jewelry at 49 Chestnut St., Newark, N. J. The co-partnership is composed of E. H. Eckfeldt, E. H. Ackley and W. B. Woodland.

Mr. Eckfeldt has represented Wm. B. Kerr & Co. for eight years, Mr. Ackley has represented Unger Bros. for six years, while Mr. Woodland has been for seven years in the factory of Larter, Elcox & Co. The first two gentlemen are widely and favorably known to the jewelry trade generally, while Mr. Woodland is familiar with all the practical and managerial requirements of a jewelry manufactory.

The new firm thus start out under the most favorable auspices and will doubtless soon carve out for themselves a recognized position in the trade. Messrs. Eckfeldt and Ackley will continue to visit their old friends who will welcome them as travelers in their own interests.

**The Jewelers' Circular for the British Government Service.**

Mr. Edward Arnold, 37 Bedford St. Publisher.  
Telegraphic Address, Strand, "Scholarly London."  
Publisher to the India Office. London, W. C. 15th Dec., 1894.

DEAR SIRS—Please mail to us regularly as issued from Jan. 1st to Dec. 31st, 1895, one copy of THE JEWELERS' CIRCULAR AND HOROLOGICAL REVIEW.

This order is part of a contract hitherto held by Messrs. Dulau, now entrusted to us. As it is for government service, kindly forward without delay, and remittance for subscription will be sent on receipt of invoice.  
Faithfully yours,

EDWARD ARNOLD,  
Per W. B.

*The Jewelers' Circular Publishing Co.,  
New York.*

ESTABLISHED 50 YEARS.

LANDEL, BAREMORE & BILLINGS,

IMPORTERS OF

DIAMONDS,

AND OTHER PRECIOUS STONES.

FINE PEARLS A SPECIALTY.

MANUFACTURERS OF

DIAMOND JEWELRY,

IN THE LATEST DESIGNS.

Diamonds Recut in Modern Styles or Repaired on Premises.

58 Nassau Street,  
29 Maiden Lane,  
NEW YORK.

1 Tulp Straat,  
AMSTERDAM.

1 St. Andrews St.,  
Holborn Circus,  
LONDON, E. C.



TRADE MARK.

ESTABLISHED 1841.

CARTER, SLOAN & CO.,

MANUFACTURERS OF GOLD JEWELRY,

No. 15 MAIDEN LANE,

NEW YORK.

A. CARTER JR.  
A. K. SLOAN.  
C. E. HASTINGS.

GEO. R. HOWE  
WM. T. CARTER  
WM. T. GOUGH.

FACTORY, NEWARK, N. J.



JOHN N. DISSELKOEN,

Gutter and Importer of

DIAMONDS

FACTORY  
73 LANGBLEEKERSPAD  
AMSTERDAM.

19 East 16th St.,  
NEW YORK.



## Our Traveling Representatives

Traveling representatives may consider these columns open for the publication of any news or items of interest regarding themselves or their conferees.

THE fourth annual election of officers of the Commercial Travelers' Club, 15 W. 31st St., New York, took place on the night of Dec. 19, and resulted as follows: President, John L. Shepherd; vice president, Charles G.

Braxmar; treasurer, E. F. Cronin; secretary, Union Adams; board of governors, John H. Black; M. A. Dominick, R. L. Gibbs, T. T. Brown, J. F. Hitchcock, A. J. Kelly, J. H. Goldman, C. F. Betts, A. H. Kellogg and John H. Bacon.

It will be seen from the above list of officers that the jewelry industry is well represented, both president and vice president being well known denizens of Maiden Lane and vicinity.



JOHN L. SHEPHERD,  
PRESIDENT, COMMERCIAL TRAVELERS' CLUB.

John L. Shepherd, who besides being president of the Commercial Travelers' Club, is also ex-president of the Jewelry Travelers' Association of New England, is one of the best known traveling men in the country. He began his travels in 1861, when, at the age of 18 years, he joined the First Virginia Regiment. He was born in Virginia in 1843 and served in the army three years, ending his military career in Libby Prison, from which he escaped in 1864. He subsequently located at various times in southern Indiana, Illinois, Pennsylvania and St. Louis, where he published newspapers with varied success. In 1878 he left the newspaper business and started on the road for the Keystone Watch Case Co. as missionary, visiting every town in the United States of over 1,500 inhabitants, and even going to Europe to introduce the Keystone Co.'s products to the retail jewelers. During the five years he occupied this position he became acquainted with thousands

of jewelers all over the country. In 1883 he was appointed manager of the New York office of the concern. He still continues to visit the trade of New York and New England. He is a member of U. S. Grant Post, No. 327, an incorporator of the Commercial Travelers' Club, a member of the Boston Jewelers' Club, Twilight Club, Central Lodge, and vice president of the Long Island Wheelman of Brooklyn. He was recently appointed aide-de-camp, with the rank of Colonel, to Commander-in-Chief Lawler, of the G. A. R.

C. G. Braxmar is one of the best known badge and medal manufacturers in the United States. Mr. Braxmar was born in Bennington, N. Y., in 1850, and after receiving an education in his native town worked on a farm until he was 18 years of age. In 1868 he started on the road selling badges on his own account, and in 1875 opened a business in Rochester, N. Y. Two years

later he went to New York and started a small workshop at 22 Ann St., where the entire product was manufactured by himself assisted by a boy. From the first he showed a remarkable prolificacy in introducing new designs and his business rapidly advanced. In 1881 he moved to larger quarters at 36 Cortlandt St. Two years ago he moved to 47 Cortlandt St., where his office and factory are now located, the latter employing about 30 men.

Mr. Braxmar possesses all the qualities that go to make a successful man. He is a member of the Manhattan Athletic Club and the following orders: Commonwealth 409, F. & A. M.; Palestine Commandery No. 18, New York; Lodge of Perfection of New York; Council Princes of Jerusalem of New York; Chapter of Rose Croix, New York; Consistory of New York; Northern Jurisdiction and Mecca Temple, A. A. O. N. M. S., New York, and other orders and clubs. He has long been a "commercial" in his own interests.

Commercial travelers' clubs in many cities have been consolidated through the efforts of E. C. Mathewson, into a National League, with headquarters at the New York branch. On Dec. 22 two delegates from each club met in the Marlborough Hotel and re-elected the following executive officers: E. C. Mathewson, New York, president; E. S. Benedict, Boston; T. R. McGrath, Syracuse; S. Low, Albany, vice-presidents; J. J. Stoneham, Philadelphia, treasurer; F. S. Jenkins, Baltimore, secretary.

Wm. L. Supple, who has been with Wm. B. Kerr & Co., New York, will after Jan. 1, represent Wm. B. Durgin, Concord, N. H., taking the place of Fred. Leigh, who re-

tires. Richard T. Supple, who has represented Mr. Durgin the past year, will continue in this capacity and cover his old territory.

Traveling salesman Haughn, representing S. A. Rider & Co., St. Louis, Mo., was in Salt Lake City recently. On departing from the store of one of his customers, he left his valise, containing \$2,000 worth of jewelry, to be sent for later. In the meantime, a traveler in another line left a valise of similar appearance to Haughn's at the same place. The latter sent for his package first and the expressman, by mistake got the jewels. When Haughn discovered his loss he was excited, and going to the police, caused several arrests before the mistake was discovered and the jewelry returned.

### Philadelphia.

H. Muhr's Sons have been busy since the holidays taking stock preparatory to the dissolution of the firm. It is expected that this task will consume some time, and that then some important announcements will be made concerning business arrangements interesting to the trade.

Frank H. Pon, 50 Franklin St., a repairer, was given a watch by Miss Helen M. Foster, Haddonfield, N. J., some time ago to repair. He didn't repair it, but disposed of it otherwise. He was arrested last week and committed on bail for court.

Traveling men were few in Philadelphia last week. There was no disposition to buy, and well known men contented themselves with looking into stores, wishing the compliments of the season, and skipping out again. There was no "opening of goods."

Local men are talking this week of the failure in Bethlehem, Pa., of James K. Rauch, who confessed judgment to his wife in the sum of \$10,000. Mr. Rauch is very well known in Philadelphia, and inasmuch as his embarrassment was not at all suspected there is considerable speculation as to the cause.

John P. Taylor on Dec. 27 began an action against Eugene F. Schmidt and Henley. Taylor says he entered the store of the defendants to purchase a chain or watch guard, and after inspecting the stock and not being suited he was about to leave when Henley informed him that a gold chain was missing and accused him of having stolen it. Taylor says the door was then locked and he was detained until the arrival of a policeman when he was searched, and the chain not being found upon him, he was allowed to depart. Taylor says that by reason of the detention and accusation he has been subjected to great bodily distress, mortification and anguish, and he demands judgment against the defendants for \$10,000 damages.

Henry Holtel, Oldenburg, Ind., has retired from the jewelry business.

### The Death of George Wilkinson.

PROVIDENCE, R. I., Dec. 28. — George Wilkinson, who has been for many years general designer and superintendent of the Gorham Mfg. Co., died at the works, in Elmwood, at about 10 o'clock this morning. Mr. Wilkinson came to the office, as usual, this morning, in apparent good health. As he entered his office he became suddenly weak and sank into a chair. Medical assistance was summoned, but he gradually grew worse and passed away quietly in the presence of his wife, the president and vice-

ued to work at his trade in Birmingham, until discovered by the Ames Co., of Chicopee, Mass., who, in 1854, brought him to America. The Chicopee firm, as is well-known, were among the pioneers in the business of manufacturing silverware. Mr. Wilkinson remained but a short time with the Ames Co., leaving to engage in business on his own account as an art die cutter and designer. In 1857 he decided to cast his lot with the Gorham Co., then a rising concern, and he remained till January, 1860, when he went with J. R. Went to New York, and became a member of the

in that position until his final retirement about a year ago.

Mr. Wilkinson's especial value to the Gorham Co. was as general superintendent, a position he assumed on the death of Henry E. Lathrop in 1870, and the marvelous success of this company was in a great measure due to the cultivated taste and artistic skill of Mr. Wilkinson. He was an enthusiast in art, not alone as a reader who endeavored to familiarize himself with the elements that constituted the various schools, or as a collector who strove to gather about him as many works or examples as possible for illustration, but in the practical application of the canons of the various schools in the development of industrial art upon a truly artistic basis. He was not one of those whose favorite occupation was the use of the pencil, for in the work of drawing he did not excel. But when it came to applying the principles of art to the silver or the bronze or whatever was in hand, his true artistic genius declared itself. He knew immediately to what department or school any design or part of a design belonged, and nothing caused him more discomfort than to see the incongruous mingling of two schools that by no sort of artistic reasoning could be harmonized.

It is said that during the prevalence of the craze for Japanese designs a few years ago Mr. Wilkinson was almost constantly shocked by the flagrant violations of the rules that were to be found upon every hand. He was an ardent student of nature, and from that grandest of all schools he drew inexhaustibly. And his reward lies in the fact that he was not only acknowledged as the artistic power in the greatest of all American art metal industries, but it has been said of him and doubtless with a considerable degree of truth, that he became to the metal industry of the United States during the period of its most rapid development what Josiah Wedgwood was to the pottery industry of England during its rise, about a century earlier.

There was method in everything that he did, too. Knowing the effect upon himself, he rightly judged that, surrounded by works of art, breathing an atmosphere of art, his assistants would partake of the proper enthusiasm, that which animated him; that from seeing they would come to discussing, and from that to putting into practical use. And the result was quickly apparent. In the furtherance of these plans he gathered at the Gorham works one of the finest art collections extant, which is a power in educating every one who comes in contact with it. No one was a more interesting talker upon art subjects, and none enjoyed the society of the artist more. His interviews with Buchanan Read, when that great artist was visiting here, are remembered by many, especially by those who were so fortunately situated as to be able to engage, in a manner, in the conversation. Each enjoyed the society of the other as true artists would be expected to do.

Mr. Wilkinson was married in 1847 in

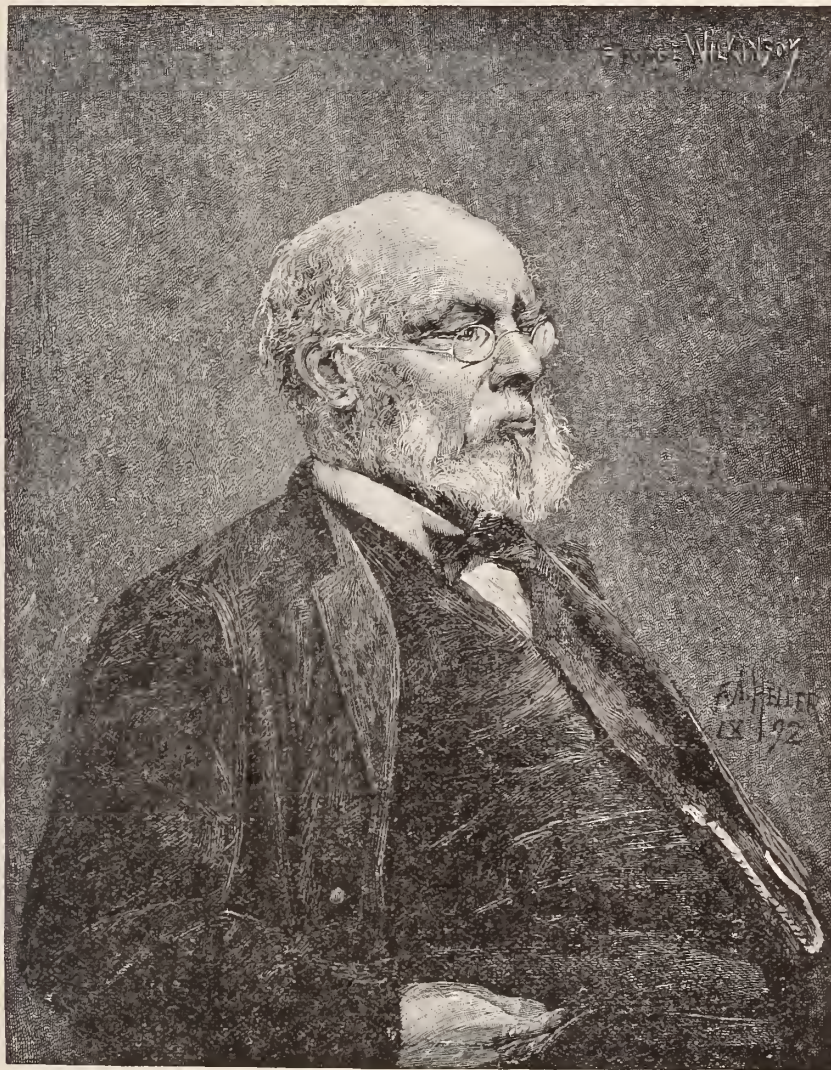

THE LATE GEORGE WILKINSON.

president and several other officers of the company. Mr. Wilkinson was stricken with paralysis some months ago, which weakened him considerably. His death this morning was due to a second stroke.

George Wilkinson was born in Birmingham, England, April 13, 1819, the son of George Wilkinson. His early life was devoted first to the acquirement of the rudiments of an education, and then, as he began to approach the threshold of young manhood, he was apprenticed to learn the trade of silversmithing. After finishing the necessary term of probation he contin-

ued to work at his trade in Birmingham, until discovered by the Ames Co., of Chicopee, Mass., who, in 1854, brought him to America. The Chicopee firm, as is well-known, were among the pioneers in the business of manufacturing silverware. Mr. Wilkinson remained but a short time with the Ames Co., leaving to engage in business on his own account as an art die cutter and designer. In 1857 he decided to cast his lot with the Gorham Co., then a rising concern, and he remained till January, 1860, when he went with J. R. Went to New York, and became a member of the

firm of Rogers, Went & Wilkinson, who were to become makers of silverware for Ball, Black & Co., then the rivals of Tiffany & Co. The co-partnership was not of long duration, for in August it was dissolved, and Mr. Wilkinson returned to the Gorham Co., in this city. Here he has ever since remained. He soon acquired an interest in the concern, and when the company were at length organized, Jan. 1, 1865, under articles of incorporation granted two years earlier, Mr. Wilkinson was elected a director. By successive elections he was retained

Birmingham, and his family numbered 13. Of these ten survive, with his wife. His ailment had existed for a longer period than is definitely known. Like most cases of the disease which resulted in his death, Bright's disease, the trouble was not at first detected. Indeed, no serious trouble was looked for until last Winter, when he was visiting in Florida. Then the first warning came in a mild attack of facial paralysis. From that time there was a steady decline, with occasional fitful rallies until the end.

Thus Providence has lost a citizen, who from his modesty and habits, was perhaps not so generally known here as many others, yet throughout the silver industry of the world, was famous. It is a remarkable coincidence that his death should have occurred not only at the works with the fame and success of which his name was inseparably united, but that the event should have come but two days after there had been set up in Roger Williams Park, the statue of the Fighting Gladiator which he had presented to the city, and which thus appropriately though unwittingly, he had provided not only as the final work of his career, but as a lasting memorial to himself and his labors.

#### Herman A. Ockel Makes an Assignment.

PROVIDENCE, R. I., Dec. 20.—At noon today Herman A. Ockel, conducting business at 159 Westminster St., made an assignment to his attorney, William Fitch. Mr. Fitch, who was interviewed this afternoon, states that nothing can yet be given for publication, as the amount of the liabilities is not known and will not be until after an inventory is taken during the coming week. There are no preferred creditors. Mr. Fitch took charge of the store immediately and put a man in charge.

H. A. Ockel has one of the largest retail stores in the city and has been engaged in the jewelry business for nearly 20 years. About a year ago he removed to large and finely equipped quarters at 159 Westminster St., and enlarged upon his line of jewelry, watches, clocks and music boxes, and has been doing a very good business. The business depressions, and difficulty of turning his large and valuable stock and the maturing of certain obligations forced him to make an assignment in order to escape other complications.

The new firm of Jones & Woodland, 49 Chestnut St., Newark, N. J., whose announcement appears on another page, possess the elements that achieve success. The members of the firm are known favorably far and wide in the jewelry trade, they have a grasp of the jewelry business in all its requirements, they are progressive and will seek constantly to produce timely and salable goods. Messrs. Jones and Woodland will cover their old territories in which they have gained numerous friends during their years of travel for other firms.

## TENTH ANNUAL MEETING AND BANQUET OF THE MANUFACTURING JEWELERS' BOARD OF TRADE.

PROVIDENCE, R. I., Dec. 29.—The year 1884 was marked by a series of disastrous and apparently, unnecessary failures, and these, together with the unbusiness-like indulgences, such as dating ahead, consigning of goods and non-adherence to terms, created a feeling of indignation among the manufacturing jewelers that was deep and bitter, so much so that several members of the New England Manufacturing Jewelers' Association proposed the introduction into that Association of a sort of a mercantile branch. There was considerable objection raised to this idea and at length these enterprising gentlemen conceived the idea of forming a Board of Trade. The idea



DUTEE WILCOX,  
PRES. MFG. JEWELERS' B. OF T.

took tangible shape and a meeting was held. The interest was so great that the present Manufacturing Jewelers' Board of Trade was organized, and November 1st, 1884, the officers were elected and the organization made permanent.

Ten years have since rolled by and during the time the Board has been a power of good to its members in protecting them in great degree from the schemes and unscrupulous dealings of dishonest buyers. Today the tenth annual meeting was held and was largely attended. The meeting was interesting and instructive and the Board has undoubtedly entered upon a new and more prosperous era of existence.

The meeting was called to order promptly at 2 o'clock by president Dutee Wilcox, Secretary Marcus W. Morton read his annual report as follows:

PROVIDENCE, R. I., Dec. 29, 1894.

To the Officers and Members of the Manufacturing Jewelers' Board of Trade:

GENTLEMEN—I have the honor to submit herewith the annual report of the proceedings and transactions of this office for the current year.

During the period since the last annual meeting, the following named corporations, firms and individuals have met with reverses in their business career: A. S. Adams, Boston, Mass.; H. W. Holbrook & Co., Bos-

ton, Mass.; E. H. Saxton & Co., Boston, Mass.; H. T. Spear & Sons, Boston, Mass.; W. L. Ballou & Co., Providence, R. I.; J. R. Feeley & Co., Providence, R. I.; G. C. McCormick & Co., Providence, R. I.; M. M. Eickstein & Co., New York City; Horton & Fitzsimmons, New York City; A. B. Kapp Mfg. Co., New York City; George Karmel, New York City; M. J. Lichtenberg, New York City; Jose Ma Menendez & Co.; Manheimer & Bibas, New York City; Phenix Jewelry Co., New York City; Prince & Schone, New York City; J. Rothschild, New York City; E. B. Schiller, New York City; J. T. Scott & Co., New York City; W. J. & C. I. Smith, New York City; J. B. Yates, New York City; Liebman Bros., Brooklyn, N. Y.; N. A. Soggs, Binghamton, N. Y.; S. & D. D. Gutman, Rochester, N. Y.; L. E. Freedman, Buffalo, N. Y.; R. Freedman, Buffalo, N. Y.; H. M. Betz Watch & Jewelry Co., Philadelphia, Pa.; C. W. Lautenbach & Co., Philadelphia, Pa.; M. Ollendorff, Philadelphia, Pa.; Philadelphia Optical & Watch Co., Philadelphia, Pa.; Queen & Co., Philadelphia, Pa.; J. Rosendale, Philadelphia, Pa.; A. L. Gossman, Pittsburgh, Pa.; Heckel, Bieler & Co., Pittsburgh, Pa.; L. H. Goldsoll & Bros., Cleveland, O.; A. Jankau, Cleveland, O.; A. B. Bell & Co. (Chicago Watch Co.), Chicago, Ill.; W. H. Bigler, Chicago, Ill.; A. Coulter & Co., Chicago, Ill.; H. Dyrenforth, Chicago, Ill.; L. L. Norton, Indianapolis, Ind.; F. S. Ring, Detroit, Mich.; A. R. Brooks Jewelry Co., St. Louis, Mo.; Siegfried, Schulein Mercantile Co., St. Louis, Mo.; Donelson Jewelry Co., Minneapolis, Minn.; W. L. Pettitt & Co., Minneapolis, Minn.; G. Wolf & Co., Louisville, Ky.; N. B. Shyer & Co., Nashville, Tenn.; F. E. Kern, El Paso, Texas; J. W. Stern & Co., San Francisco, Cal.; H. Wolff, San Francisco, Cal.; J. L. Solomon, San Francisco, Cal.; Simon Rumpf, Seattle, Wash.; Est. E. Eaves, Montreal, Can. Making a total of 54. Representing \$138,987.65.

The following have either compromised with their creditors or dividends have been paid by assignees or Courts of Insolvency:

W. A. Bigler, in full 1 creditor, \$720.  
A. S. Adams, 50 per cent. 9 creditors, \$5,126.91.  
H. W. Holbrook & Co., 20 per cent. 4 creditors, \$599.25.  
E. H. Saxton & Co., 20 per cent. 13 creditors, \$4,123.08.  
H. T. Spear & Sons, 31½ per cent. 8 creditors, \$1,303.94.  
G. C. McCormick & Co., 25 per cent. 28 creditors, \$2,660.88.  
J. Ma Menendez & Co., 30 per cent. 6 creditors, \$1,491.82.  
J. T. Scott & Co., 40 per cent. 62 creditors, \$50,923.16.  
N. A. Soggs, 12½ per cent. 12 creditors, \$1,529.19.  
C. W. Lautenbach & Co., 25 per cent. 2 creditors, \$29.43.  
A. Coulter & Co., 25 per cent. 11 creditors, \$896.03.  
L. L. Norton, 30 per cent. 5 creditors, \$481.42.  
A. R. Brooks Jewelry Co., 20 per cent. 52 creditors, \$9,238.48.  
G. Wolf & Co., 50 per cent. 5 creditors, \$1,167.12.  
Est. E. Eaves, 23¼ per cent. 18 creditors, \$2,227.29.  
J. R. Feeley & Co., 25 per cent. cash or 30 per cent. in 4, 8 and 18 months notes, secured. 4 creditors, \$482.17.  
Horton & Fitzsimmons, 25 per cent. 13 creditors, \$2,101.94.  
M. Ollendorff, 25 per cent. 5 creditors, \$1,314.11.  
J. Rosendale, 25 per cent. 15 creditors, \$5,314.02.  
H. Dyrenforth, 25 per cent. 21 creditors, \$4,474.93.

In the following composition offers are pending, with every reason to believe the same will be effected:

W. J. & C. I. Smith, 20 per cent. 15 creditors, \$3,156.31.  
W. L. Pettitt & Co., 33½ per cent. 14 creditors, \$2,007.43.  
J. L. Solomon, 25 per cent. 2 creditors, \$1,463.56.

The remaining cases of the year, briefly summed up, are:

W. L. Ballou & Co., assigned, liabilities, \$780.79; assets, inventoried at \$20,967.08. 9 creditors, \$503.42.  
M. M. Eickstein, closed by sheriff on an execution for \$1,323, and the stock sold for \$1,230. 29 creditors, \$2,630.25.  
George Karmel, assigned, liabilities, \$6,100.22; assets, \$4,014.80. 1 creditor, \$187.51.  
N. J. Lichtenberg, confessed judgment for \$6,033.11. Liabilities about \$40,000, of which \$10,000 was for merchandise; balance, borrowed money. Several judgments have been entered against him. 11 creditors, \$1,910.25.  
P. Manheimer & Bibas. The senior member confessed judgment for \$1,020, whereupon the other, not joining in the confession, applied to the courts for a receiver, which was granted. 12 creditors, \$2,296.28.  
Prince & Schone, closed by mortgage. 3 creditors, \$96.02.  
E. B. Schiller, assigned, liabilities about \$10,000; assets appraised at stock, \$1,400; accounts, \$600; total, \$2,000. An offer in composition was made at 20 per cent., but was withdrawn. 29 creditors, \$4,385.43.  
J. B. Yates, assigned, liabilities, \$589.35; assets, \$19,500. 12 creditors, \$1,688.65.

J. Rothschild, closed by sheriff, and stock sold to satisfy the execution. Judgments have also been entered against him. 12 creditors, \$1,908.12.

Phoenix Jewelry Co. (D. Berhend), closed by sheriff. 6 creditors, \$161.

A. B. Kapp gave bill of sale to B. Selig & Co., and Selig & Kaufman, of Philadelphia, for borrowed money and endorsements, also to cover his father for loans. Coming to Providence December 1st, he was arrested on three writs, and failing to secure bonds was confined in jail. During the following Monday and Tuesday, many additional writs were issued; he was released the next succeeding week on bonds aggregating about \$10,000. Application to take the poor debtor's oath was made, and citations issued for Dec. 26th to show cause why same should not be granted. A goodly number of creditors of the Board were present at the hearing, which was at the Providence County Jail, before George N. Bliss, Judge of Sixth District Court. Other creditors were represented by various attorneys, the examination of Mr. Kapp being chiefly conducted by Stephen A. Cooke, counsel for the Board, assisted by Frank Jackson. A continuance was granted by the court until Saturday, January 5, 1895, at 10 o'clock A. M., 35 creditors, \$3,971.93.

Liebmann Bros., closed by sheriff. 4 creditors. \$174.23.

S. & D. D. Gutman, gave bill of sale to Flour City Bank, Rochester, N. Y., to secure a claim of \$7,000. Subsequently the sheriff levied on the stock and fixtures on an execution for \$1,200. 17 creditors, \$4,447.68.

R. Freeman, closed on chattel mortgage. 6 creditors, \$401.84.

L. E. Freedman, gave chattel mortgage on stock and fixtures for \$2,000 and real estate mortgage for \$500. 8 creditors, 1,145.12.

H. M. Betz Watch & Jewelry Co., closed on execution for \$8,002.80. 3 creditors, \$250.09.

Philadelphia Optical & Watch Co. affairs presented a very tangled state. An assignment was made. Receivers appointed by the court, and litigation without end seemed probable. The sheriff finally disposed of the stock and fixtures for about \$70,000. 12 creditors, \$4,753.95.

Queen & Co., assigned, liabilities, \$200,000; assets, \$104,000. 7 creditors, \$669.81.

A. I. Grossman, closed by sheriff on execution for \$1,200. 12 creditors, \$1,225.17.

Heckel, Bieler & Co., closed on execution amounting to \$17,000. 13 creditors, \$913.80.

L. H. Goldsoll & Bros. The first difficulty to this firm appeared when L. H. Goldsoll was indicted by the Grand Jury, on the charge of promoting a lottery or other game of chance. Following came action by creditors asking for a receiver, which was not granted; then proceedings were begun to replevin goods in hand of the Merchants Banking & Storage Co., to whom the firm had transferred quantities of property in original packages. These proceedings were attended with much success, but the goods thus obtained were held by the company on re-delivery bonds, and the various suits are still pending. For awhile the brothers were fugitives from their city, warrants for their arrest having been sworn out, for obtaining goods under false pretenses. At the trial before the justice the younger brother, Joseph, was discharged, while his brother, L. H., was bound over for appearance before the Grand Jury; by whom a true bill was found against him and the cause placed on the calendar; just when it will be reached cannot be stated. 26 creditors, \$12,779.30.

A. Jankau, closed on chattel mortgage. 4 creditors, \$118.45.

A. B. Bell & Co. (Chicago Watch Co.) confessed judgment for \$1,900. 2 creditors, \$139.85.

F. S. King, closed on chattel mortgage. 19 creditors, \$3,570.72.

Siegfried Schullen Mercantile Co., closed by sheriff. 3 creditors, \$355.53. While in Kansas City, Mo., some two years ago, under name of Siegfried Schullen & Co., they made a bad failure, creditors never realizing on their accounts.

Donelson Jewelry Co., assigned. Liabilities, \$7,500; assets, \$4,500. 2 creditors, \$458.59. The court has granted petition of creditors to share in the assets without filing releases, as is usual in assignments, on grounds of fraud.

N. B. Shyer & Co., made special assignment, and gave deed of trust to Nathan Cohn as trustee, who is directed to sell all property conveyed, and to apply the proceeds to the payment of certain claims mentioned in said deed and in the order mentioned, paying those first named in full, before paying anything upon the others. Exhibit "A" shows four creditors, \$1,724.81. Exhibit "B" shows nine creditors, \$2,725.78. The value of the property conveyed is estimated at \$3,000 so that the creditors in class "B" are not very much better off than general creditors. 16 creditors, \$3,606.24.

P. E. Kern, assigned. Liabilities, \$57,000; assets, \$42,000. In March last Mr. Kern obtained an extension giving a deed of trust for his property for the benefit of his creditors. 4 creditors, \$317.48.

J. W. Stern & Co., assigned all their stock in trade for benefit of local creditors, which under the laws of California simply means nothing for foreign or non-resident creditors, unless five resident creditors join in a petition to set aside the assignment and have debtor declared insolvent. This we were unable to do. 17 creditors, \$1,906.66.

H. Wolff, some two years ago, became involved in divorce litigation with his wife, who succeeded in obtaining a decree of divorce, and alimony was awarded her. This latter he refused to pay; having reached the sum of \$4,000 he was cited to show cause why it should not be paid. To purge himself of contempt, he had all his property transferred through means of sheriff's sale, and insolvency proceedings were instituted, which were pending at last advices. 20 creditors, \$2,516.41.

S. Rumpf gave bill of sale August 29, after buying heavily of Eastern manufacturers and dealers, and at once left for parts unknown. Application for a receiver was made and Albert E. Griffin appointed by the Court with bonds at \$8,000. Rumpf is believed to have gone to Bavaria. 3 creditors, \$1,152.76.

In the following cases reported in 1893, dividends in whole or part, have been paid by assignees, receivers or trustees during the year:

Reinhardt & Co., Pittsburgh, Pa., 33 1/2 per cent.

C. F. Allcott & Co., Milwaukee, Wis., 32 per cent.

J. R. White Jewelry Co., Rochester, N. Y., 30 per cent.

J. Rosenstock & Co., Baltimore, Md., 10 per cent.

F. G. Smith, Sons & Co., Detroit, Mich., first dividend, 10 per cent.

Hoffman Bros., New York City, the dividend was so small it was returned by some creditors.

J. N. Bonnet, New York City, 13 per cent.

Of cases formerly reported:

Baldwin & Co., St. Joseph, Mo., all claims in the first deed of trust have been paid. The second deed, covering those creditors who compromised their accounts has been filed, and it is expected they will be paid in the near future.

Greene & Smith Watch & Diamond Co., Denver, Col., whose property was purchased by the principal creditor, was turned over to a local firm to dispose of. Mr. Knox, the purchaser, has intimated a composition with other creditors, but nothing substantial has developed.

In the J. M. Chandler Co., Cleveland, O., a dividend may be expected soon from Trustee Sigler, at least so our attorney informs us.

In the A. Bernhard & Co., New York, the assignee was ready to report and distribute the estate in his hands; legal objections having been entered no conjecture is reliable as to when it may be heard from again.

The Burt & Hulbert Co. appears to have gone entirely to pieces; the wreck being so complete that there is nothing visible against which an execution is available.

The affairs of the Providence Jewelry Co., St. Louis, Mo., are being closed up, and the creditors' committee had entertained hopes of making a final report before the end of this year. The larger part of merchandise creditors have been settled with upon a basis of 33 1/2 per cent., which has been the rate paid to all. As the affairs have not been finally adjusted, it is necessary to maintain the Missouri corporation.

In the composition settlement of the Giles Bros. & Co., Chicago, Ill., creditors have been notified of the inability of the firm to pay the outstanding notes which were taken in part settlement. This reduces the dividends actually received to 15 per cent., which was cash. The matter has been referred to our attorneys.

REPORTS.

There were 609 regularly numbered and 351 incidental reports issued, and 1,997 inquiries answered during the year.

COLLECTIONS.

Claims received.....		434
" collected.....	270	
" withdrawn.....	10	
" uncollectable, returned.....	32	
" reduced to judgment.....	10	
" pending.....	112	434
Representing.....	\$51,127.65	
270 collected.....	\$28,095.20	
10 withdrawn.....	4,134.29	
32 uncollectable.....	2,680.41	
10 in judgment.....	1,208.79	
112 pending.....	15,008.96	
	\$51,127.65	

Of this amount \$14,856.13 was without expense to members.

MEMBERSHIP.

Number of members last report.....	99
Admitted.....	26
	125
From which deduct	
Resigned.....	8
Dropped.....	2
Expelled.....	1
Out of business.....	4
	15
Present membership.....	110

The first decade of the Manufacturing Jewelers' Board of Trade has passed, and its history, written or unwritten, has been made.

It is a matter of much regret that for the first two years no record was kept of accounts placed for collection, either as to amount or number; also in the number of failures and amount thereof, for the first year. With three exceptions, the records are complete to date, and while no satisfaction may be gained or profits accrue by a presentation of the following facts and figures, it may prove an interesting study to those who desire to pass in review their business covering this period.

COLLECTIONS.

Claims received, 2,297, amounting to.....	\$286,851.60
Of which 1,147 were collected, amounting to.....	173,840.04
204 withdrawn, amounting to.....	30,625.64
334 uncollectable.....	31,043.81
72 reduced to judgment, ".....	23,400.96
3 compromised, ".....	350.89
210 pending, ".....	27,499.36
	\$286,851.60

Of the amount collected, \$84,191.18 was without expense to members.

FAILURES.

Covering a period of nine years there has been 317 failures of individuals, firms and corporations, an average of 35 for each year. The total amount involved in these disasters is \$1,350,690.86. An average to each failed case of \$4,260.85. Of this amount \$506,852.23 has been compromised upon a basis ranging from 20 to 75 per cent. or an average of 42 per cent.

There has been paid, either by Courts of Insolvency, Assignees, or Trustees, a further amount of \$28,951.95, the percentage being from 2 to 41 8/10, an average of 16 per cent.

The year 1890 presents the least amount involved, being but \$55,196.70, while 1893 shows the greatest amount, \$244,563.66, with 1892 a close second in the list, \$20,719.77. The smallest number of failures in any year was 1889, when 16 was the record; the largest was in 1893, when 67 were recorded. Nearly 33 1/3 per cent. of the entire number of failures were settled by compromise or by dividends paid by the legally authorized parties.

It has been conceded that a large percentage of all the financial failures arise from a lack of capital. Men of good moral character and habits, not extravagant in the granting of unwise credits nor engaged in questionable transactions of a fraudulent nature, but have simply overloaded themselves, and extended beyond the point of their capital limit without a thought or consideration whether or not they were justified, have gone down alike with the unscrupulous and fraudulent debtors in the vortex of disaster.

Considering the item of failures the past decade, how much can be attributed to the desire of the manufacturer to dispose of his products thus not only subjecting himself to loss, but aiding in the disaster and ruin of the jobber or dealer. If it be true, then there exists an evil which should be eradicated. Much, very much, of the entire business of the country is done on credit, the amount of which is beyond conception. It has been said, truthfully too, I think, that each and every case of credit is one in and of itself, and that no arbitrary rule can be laid down, for the circumstances and conditions are peculiar to each.

Is it not a fact that it is not so much the need of rules to apply, as a more complete and thorough knowledge of credits and their application. It is with this end in view, that our mercantile houses have their "credit man" whose entire time and energy is devoted to the interests of his house, that the least possible loss may entail.

The granting of credit is a necessity, and should be governed largely on a moral basis. Admitting this to be true, it follows as an invariable rule that the true moral and financial condition of every applicant for credit should be fully known. To obtain this information, to which reliance is placed on the various mercantile agencies; all proper and right in so far as they go, but personal investigations should never be superseded by these reports. Know your man, his character, habits, mode of living, his family relations, whether he is a man whose home is his ideal, or he is considered a "high roller" "by the boys." Beware of the "hustler," whether it be two years or twenty years of hustling, the inevitable will come, and the loss will be heavy.

In conclusion permit me to present the parody on Hamlet's soliloquy, taken from the book on "Whom To Trust."

To sell or not to sell?  
That is the question  
Whether it is better to send the goods  
And take the risk of doubtful payment,  
Or to make sure of what is in possession,  
And, by declining, hold them.  
To sell; to ship, perchance to lose—  
Aye, there's the rub!  
For when the goods are gone  
What charm can win them back  
From slippery debtors?  
Will bills be paid when due?  
Or will the time stretch out till the crack of doom?  
What of assignments, what of relatives,  
What of uncles, aunts and mothers-in-law,  
With claims for borrowed money?  
What of exemptions, bills of sale, and the compromise  
That coolly offers a shilling a pound,  
And of lawyer's fees  
That eat up even this small pittance?  
Yet sell we must;  
We seek the just;  
For wealth we lust;  
By some we are cused;  
And stocks will rust;  
But we skip the wust;  
Or we'd surely bust.

Respectfully submitted,  
MARCUS W. MORTON,  
Secretary.

This report was ordered printed and distributed to members of the Board.

Treasurer Hoffman, S. Dorchester presented his annual report which showed the board to be in an encouraging financial condition.

(Continued on page 22.)

# The "TRAJAN" Pattern.

DESIGN PATENTED.



Table Spoon.  
Average Weight to the Dozen,  
28 oz.

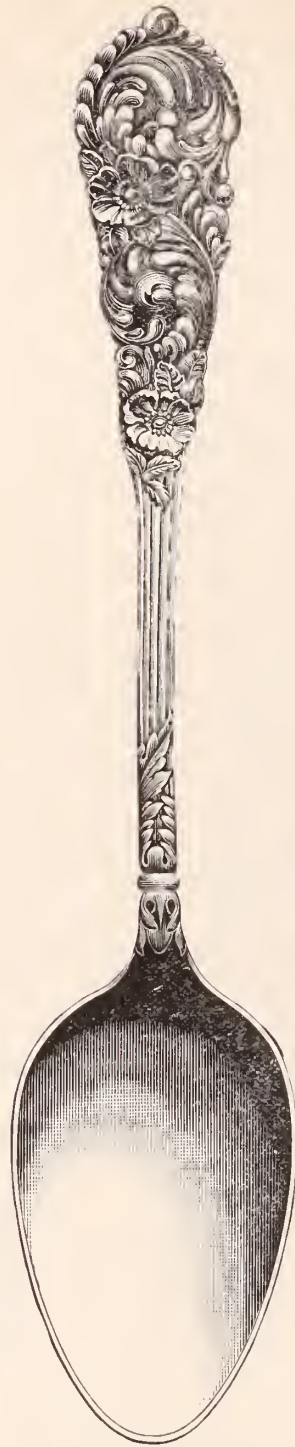

Dessert Spoon.  
Average Weight to the Dozen,  
20 oz.

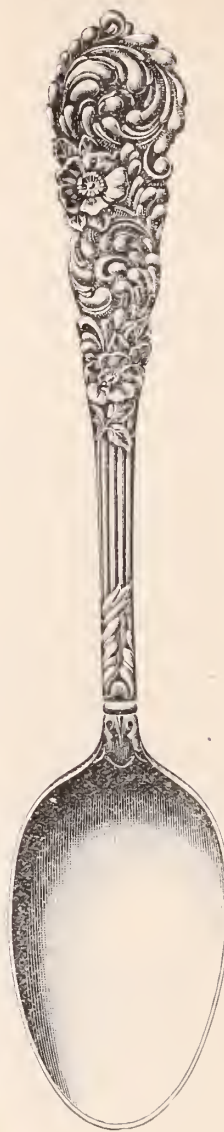

Tea Spoon.  
Average Weight to the  
Dozen,  
12 oz.



925 FINE.  
1000



Dessert Fork.  
Average Weight to  
the Dozen,  
20 oz.

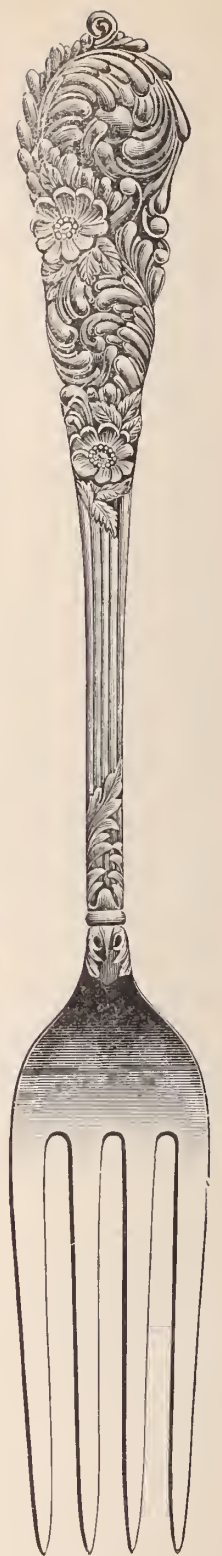

Table Fork.  
Average Weight to the Dozen,  
28 oz.

The TRAJAN Pattern is universally accepted as the richest in design and execution of any highly ornamented pattern ever offered to the trade.

It is furnished regularly in weights as specified above, and in heavier weights to order. The fancy pieces, numbering over one hundred, are artistic in design, and include all the latest ideas in Table Service.

## REED & BARTON, Silversmiths, TAUNTON, MASS.

### NEW YORK OFFICES,

CHICAGO,  
34 WASHINGTON STREET.

37 UNION SQUARE.

13 MAIDEN LANE.

PHILADELPHIA,  
925 CHESTNUT STREET.

OUR GOODS ARE WIDELY ADVERTISED IN THE MAGAZINES; A FEATURE WHICH DEALERS WILL APPRECIATE.



# The Jewelers' Circular

AND  
HOROLOGICAL REVIEW.

PUBLISHED EVERY WEDNESDAY BY

THE JEWELERS' CIRCULAR PUB'G CO.,

189 BROADWAY, NEW YORK CITY.

A JOURNAL DEVOTED TO THE INTERESTS OF JEWELERS, WATCHMAKERS, SILVERSMITHS, ELECTRO-PLATE MANUFACTURERS, AND ALL ENGAGED IN KINDRED BRANCHES OF INDUSTRY.

Our Editorial columns will contain our own opinions only, and we shall present in other columns only what we consider of interest or value to our readers. Advertising matter will not be printed as news.

Advertising rates in THE CIRCULAR are lower, considering the number of tradesmen reached by its large circulation, than in any other jewelry journal.

Notices of changes in standing advertisements must be received one week in advance; new matter can be received up to Monday.

## INFORMATION FOR SUBSCRIBERS.

### Terms of Subscription, Postage Prepaid.

	PER ANNUAL
United States and Canada, - - -	\$2.00
Foreign Countries in Postal Union, - - -	4 00
Single Copies, - - - - -	.10

New subscribers can commence at any time.

Payers for THE CIRCULAR when sent by mail, should be made in a Post Office Money Order, Bank Check or Draft, or an Express Money Order or Registered Letter. All postmasters are required to register letters whenever requested to do so.

Pay money only to authorized collectors having proper credentials.

Returning your paper will not enable us to discontinue it, as we cannot find your name on our books unless your address is given.

In changing address always give the old as well as the new one. Your name cannot be found on our books unless this is done.

We will continue to send papers until there is a specific order to stop, in connection with which all arrearages must be paid; but such an order can be given at any time, to take effect at the expiration of the subscription. All such orders will be promptly acknowledged by mail.

The Courts have decided that all subscribers to Journals are responsible until arrearages are paid in full and an order to discontinue has been received by the publisher.

Member of the American Trade Press Association.

Vol. XXIX. Jan. 2, 1895. No. 23.

*Every line of reading matter in THE JEWELERS' CIRCULAR, with the exception of the few brief extracts from exchanges always properly credited, is written exclusively for this journal. Each issue of THE JEWELERS' CIRCULAR is copyrighted.*

**Food for Thought**  
for 1895.

IT is customary at the close of the old year or the beginning of the new year for all classes of teachers, leaders and commentators to indulge in philosophical disquisitions relative to the briefness of life, the flight of time, the lessons of the past, the hopes of the future. These disquisitions too often take the form of verbose platitudes, neither teaching, leading nor commenting, and thus achieve little lasting good. But in our industry, at no time for several years past, has it been more desirable to analyze existing conditions, than at present. National legislative changes of the past year have disturbed the jewelry

trade to its very foundation, while events within the confines of the industry itself have had a tendency to enhance this disturbance.

First and foremost the changes in the tariff have affected the diamond industry to an extent unprecedented, and in a direction not calculated upon, and it is an open question whether any one has as yet profited by them. While our national legislators did not have in view the fostering of the diamond cutting industry in America when they changed the duties on diamonds, their proceedings have had apparently such an effect; we say apparently, for the projectors of the diamond shops themselves have no clear idea of the outcome of their operations. Being enterprising enough to take advantage of conditions favoring enhanced profits, their satisfaction rests in the present. Were any emphasis to this statement deemed necessary, it could be added that some of the cutters have expressed a desire to see the diamond industry in its entirety returned to its old status, in which 10 per cent. duty on cut stones and no duty on rough ruled. "There are more things in heaven and earth, Horatio, than are dreamt of in your philosophy," remarked Prince Hamlet, and there are more discouragements in the diamond cutting industry than are within the ken of the average importer who may desire to engage in the cutting business.

The principal local incident in the trade has been the establishment of retailers' associations throughout the Union. There are a number of recognized abuses that organized effort should endeavor to correct; but the methods adopted have not always met with the applause of this journal. The confirmed habit acquired by many, of reiterating in substance that the jewelry trade is going to the "demnition bowwows," the promulgation and publication in the daily press of speeches charged with hyperbolic statements to the effect that the department stores are acquiring almost the whole jewelry patronage, and the disposition to treat the jeweler as a minor business man—few sales and large profits, must ultimately have a tendency to make the public believe that the proper place to make purchases of jewelry is the department store. All agitation possible will not prevent dealers buying goods at low figures or manufacturers selling to the most profitable customers. There are not, after all, very many department stores in the country; there are perhaps over a dozen in New York, the same number in Chicago, five in Brooklyn and so on, numbering but a hundred or so throughout the United States. These cannot control every industry, though they may have a temporary baleful effect upon it. They cannot always make jewelry "a leader," for the principle of their business makes it necessary for them to seek new worlds to conquer.

It is not the question of the extension of the business of the department store which confronts the reformer; it is the question

of their principle, and as far as their industry is concerned the jewelers can fight this. A common statute should be obtained in all the States, regulating the stamping of silver and gold wares, and organized endeavor should be put forth to have the statutes enforced. Then the so-called "triple plate" which strips one quarter of that of the genuine article and the "sterling silver plate," which strips nothing whatsoever of the department store, would not be placed in competition with the jeweler's reliable articles. "Quick sales and small profits" is a principle of business which few houses can long stand, and the jeweler and dry goods dealer would soon meet on a fairly even footing. In the movement to obtain stamping legislation, many jewelers deserve recognition, notably those whose names have appeared in this column in previous issues of THE CIRCULAR, and those who are members of the Retail Jewelers' Association of Connecticut, and the Retail Jewelers' Association of Atlanta.

### The Failures of THAT reliable journal, *Bradstreet's*, in an exhaustive summary of

1894.

the mercantile failures during 1894, gives the total number of failures in the United States in that year as 12,721, as compared with 15,560 in the panic year of 1893, which was the heaviest total ever recorded. The shortage in the number of business failures in the past year contrasted with the year before, about 18 per cent., is, however moderate in comparison with the falling off of the total volume of indebtedness, which amounted during the past twelvemonth to \$149,595,000, about 37 per cent. of the aggregate liabilities in 1893. The falling off in total assets in 1894, \$79,755,000, is even greater, being only 30 per cent. of the corresponding aggregate, 1893. From these data it will be noticed that while business failures fell away about 18 per cent. in 1894 compared with the previous year the total indebtedness of those failing shrank 63 per cent., and assets, which were unduly expanded in the preceding year, decreased 70 per cent. The journal quoted construes as a sign of general healthfulness that total liabilities for 1894 are much smaller than in 1891 or 1890.

MICHIGAN manufacturers have started a movement which should be repeated by manufacturers of every other State. They have asked the Legislature to enact a law making it compulsory that all prison made goods shall be labeled as such, and that a brand be used instead of a label on all goods possible. This would prevent imposition by dishonest dealers, and would protect the laboring classes as well as the manufacturers. The competition of regularly made goods with prison made goods is unfair and a great injustice to honest labor. By all means let prison made goods be prominently stamped as such.

### New York Notes.

Richard Cohn, jeweler, 180 Bowery, is one of the incorporators of the Anti-Vice Society of New York, incorporated last week.

The recently formed firm of Jagulky & Ganter, manufacturing jewelers, 176 Broadway, have dissolved by mutual consent. L. Jagulky continues the business at the old address and Mr. Ganter becomes a jeweler for the trade at 10 John St.

A sale of the property assets and accounts in the hands of John B. Brown, as assignee of John B. Yates, is advertised to take place on Tuesday, Jan. 15th, at the office of the Montgomery Auction and Commission Co., 132 Front St.

Last Wednesday the sheriff took charge of the store of Gerson Gootenberg, a retail jeweler at 448 Grand St., on an execution for \$936.06, in favor of Henry Delerson. Gootenberg deals principally in second hand jewelry and musical instruments. He has been in business for himself about 10 years.

Anna E. Street, the nine year old daughter and only child of H. L. Street, of Geo. O. Street & Sons, died at her home Thursday evening from peritonitis after an illness of a few days. The funeral took place Saturday evening at the residence of her parents, 89 Cambridge Place, Brooklyn.

Stephen G. Patterson, assignee of Joseph Rundbach, obtained from Judge Bischoff, of the Court of Common Pleas, Thursday, an extension of 30 days from that date, in which to file his schedules of the assigned estate. Assignee Patterson claims that the reason he has been unable to make up his schedules is owing to the fact that a large part of the assigned property is held by the sheriff under attachment, while other goods are in the possession of Property Clerk Harriot. Rundbach who was a retail jeweler at 2168 Third Ave., is now under indictment for concealing property with intent to defraud creditors.

Two attachments were received by the sheriff Thursday, against the East Side Jewelry Exchange, 332 Grand St, one in favor of Max Speiser for \$1,025, money loaned, and the other for \$225 in favor of Albert Reitman. A judgment for \$42.48 against the same company was entered Friday in favor of Hipp Didisheim & Bros. The East Side Jewelry Exchange, of which Adolph Raduziner is manager, is incorporated under the laws of New Jersey with a capital stock of \$5,000. The incorporators are principally creditors of Raduziner and his wife, both of whom have failed in business. They are Arnold Kohn, Gottlieb Glauber, Frederick Kaffeman, Bernard Weinberger and Leo Kohn. Arnold Kohn, a member of the firm of Alois Kohn & Co., is president of the concern and Leo Kohn, secretary and treasurer. Adolph Raduziner, the manager, has failed twice, once in December, 1887, when he settled at 50 cents and again in July, 1891.

The Derby Silver Co., C. Dorflinger & Sons and Wm. B. Durgin, Concord, N. H., have been elected members of the New York Jewelers' Association.

A. King, of I. Emrich & Co., 52 Maiden Lane, left for Europe Dec. 29th on the *Lucania* to assist in producing the latest novelties in the firm's factory, at Pforzheim, Germany.

Martin Vassar Cable, a retired business man, 65 years old, died at his home, early Saturday morning, from heart disease. He was born in Poughkeepsie and came to this city about 40 years ago. He was in the jewelry business at Cortlandt St. and Broadway for 18 or 20 years. In 1876 he took charge of the old Belmont Hotel at 141 Fulton St. He retired from active business in 1892.

Acting Secretary Hamlin and Supt. Stump, of the Treasury Department, were unable to come to New York, as they intended last week, to hear further argument on the appeal from the decision of the Special Board of Inquiry. This decision declared that diamond cutting was a new industry here and ordered the release of H. Hoed, a detained diamond cutter on the ground that the Contract Labor Law did not apply to new industries. The concluding arguments on the appeal were therefore heard at Washington, Thursday last. No new testimony was introduced. A decision is expected within the coming week.

What appears to be a cool attempt at swindling was blocked last week by the careful methods pursued by J. B. Bowden & Co., 3 Maiden Lane. On Friday, a short, thick-set man called at the office, and stating that he was Mr. Kerr, junior member of Wm. Kerr & Son, Boston, ordered some goods. Mr. Bowden doubted his customer's honesty and telegraphing to Kerr & Son, received word that there was no one in New York who represented them or had authority to buy for them. The man who attempted to get the goods is described as a thick-set man of 26 or 27 years of about age, 5 feet 6 inches in height, and weighing about 140 or 150 pounds. He had dark brown hair and moustache and a pale complexion.

S. A. Gutman & Co., jobbers in diamonds and jewelry at 51 Maiden Lane and who have a retail store at 1146 Broadway, last week gave a bill of sale for \$22,000 to S. B. Lichtenstein. The amount of the consideration is said to be for money loaned. They also gave a bill of sale of the fixtures at the Broadway store to R. A. Breidenbach and another bill of sale of the fixtures at 51 Maiden Lane to Oppenheimer Bros. & Veith. At the office of J. C. Guggenheimer, the attorney for Mr. Gutman, a CIRCULAR reporter was told Monday that the failure was due to poor business. S. B. Lichtenstein, to whom the bill of sale was given, is a relative of Mr. Lichtenstein, the son-in-law and partner of Mr. Gutman. The merchandise indebtedness, the attorney stated, was comparatively small. No pre-

parations for a creditors' meeting had then been made. Oppenheimer Bros. & Veith, Eichberg & Co., Leon Hirsch, Sam Stern & Co., and R. A. Breidenbach are among the merchandise creditors.

### Manufacturing Jewelers' Board of Trade Meeting.

(Continued From Page 19)

dition. The trustees of the special fund reported that there was nearly \$5,000 in the fund.

The following were elected as members of the board of directors: Barton A. Ballou, Nathan B. Barton, Sidney O. Bigney, Robert E. Budlong, John M. Buffinton, Samuel H. Bugbee, George B. Champlin, Hoffman S. Dorchester, Samuel E. Fisher, William R. Dutemple, Charles E. Hancock, Everett S. Horton, James J. Horton, John Knox, George E. Luther, William S. Metcalf, George W. Parks, Clarence L. Watson, George K. Webster, Dutee Wilcox and Walter S. Williams.

This concluded the business portion of the session and an adjournment was taken at 4 o'clock until evening.

The directors will meet soon for the purpose of organization, at which time the officers and committees will be elected.

### THE BANQUET.

In the evening at 6.30 the members and their guests assembled at the rooms of Gelb & Norton, where the committee consisting of John M. Buffinton, Major E. S. Horton and G. E. Luther had arranged for a reception. As a special feature of the evening's festivities all of the surviving manufacturing jewelers of this vicinity had been invited to the number of about 30 to be present. Those who responded were Hon. Thomas Davis, formerly of Sackett, Davis & Co., 88 years of age; Pardon M. Stone, Calvin Stone, Fred. I. Marcy, E. Woodbury Dodge, Aldrich Gardiner, Robert Barton, George Allen, Sylvester Allen, Samuel Allen, James N. Hopkins, Christopher Duckworth, of Pawtucket and John H. Sturdy. For nearly an hour reminiscences were exchanged and old acquaintanceships renewed.

At 7 o'clock the entire party, which numbered more than 125, formed in procession, and to the strains of Reeves Orchestra, John S. Hanna, leader, proceeded to the banquet hall, where six long tables had been spread. Seated at the guests' table were: President Dutee Wilcox, William R. Dutemple, Major Everett S. Horton, John M. Buffinton, Fred. I. Marcy, E. Woodbury Dodge, G. F. Luther, Isaac M. Potter, George Allen, Christopher Duckworth, Samuel E. Fisher, James H. Sturdy, Marcus W. Morton, George L. Vose, George P. Tew, Aldrich Gardiner, Robert Barton, Hoffman S. Dorchester, Joseph H. Fanning, Hon. Charles Sydney Smith, Hon. F. Jillson, of Woonsocket, Hon. Thomas Davis, John W. Vernon, Senator Nelson W. Aldrich and Louis L. Angell.

Surrounding the other five tables were the following: Henry Wexel, Walter Mason,

**L. TANNENBAUM & Co.,**  
IMPORTERS AND CUTTERS OF

**Diamonds and Precious Stones,**

Cor. Maiden Lane & Nassau St.

**NEW YORK.**

25 Hatton Garden, London.

TELEPHONE, LONG DISTANCE 1959 CORTLANDT.

## Special Announcement.

Mr. L. Tannenbaum begs to notify his customers and the trade in general, that he has largely extended his facilities for cutting and polishing. Hereafter he will cut and polish not only RUBIES and SAPPHIRES, which has been done for the past 15 years with increasing and gratifying success, but

## DIAMONDS

and all other stones which undergo this process.

Modern machinery of the best and most approved pattern, and workmen of the highest class will enable Mr. Tannenbaum to offer, direct from the cutter's hands, that excellent workmanship demanded by American buyers, at

## PRICES THAT DEFY COMPETITION.

Nor will buyers of Diamonds be the only people benefited. Mr. Tannenbaum imported a five years' supply of rough Rubies and Sapphires DUTY FREE under the old tariff. These goods are now being cut and polished and it is very evident that in these particular stones he can make UNAPPROACHABLE PRICES.

New York as the future Diamond Market is not a phantasy. American cutters will be shown an assortment of rough, at prices which will perhaps cause them to believe that this has already been brought about. All arrangements have been made by the firm for enormous shipments of DIAMONDS, EMERALDS, PEARLS, SPINELS, CATSEYES, MELLÉS and all kinds of Precious Stones, although to-day the assortment offered by L. Tannenbaum & Co. ranks second to none in this country.

 HIGHEST PRICE PAID for all AMERICAN PEARLS and OTHER PRECIOUS STONES.

F. G. Pate, F. S. Gilbert, John J. Butler, Henry G. Thresher, J. P. Carpenter, J. Parker Ford, S. A. Baldwin, George Becker, Dr. George A. Brug, Albert Totten, C. A. Fraser, Frank Cutter, Everett L. Spencer, George H. Holmes, E. A. Mowry, William K. Harris, Daniel Sayles, G. H. Howard, A. D. Smith, T. I. Smith, L. W. Wise, E. E. Budlong, W. S. Williams, Samuel H. Bailey, Charles E. Hancock, Pardon M. Stone, E. R. Knight, Jr., George B. Champlin, F. B. Lawton, A. R. Dorchester, George F. Albro, W. H. Gale, Jr., Calvin Stone, Walter C. Young, William T. Chase, Walter S. Hough, Jr., Walter C. Gardiner, James R. Stone, John Fletcher, Henry Fletcher, Philip Linton, R. L. Griffith, Edwin Lowe, Charles Stanley, Nathan Barton, Fred C. Carr, Charles L. Place, Herbert B. Mason, E. I. Mulcahey, Albert O. Smith, Roswell C. Smith, Frank T. Pearce, J. L. Sweet, H. E. Sweet, C. I. McClatchy, J. T. Makinson, E. I. Franklin, W. W. Sherman, Lieut. H. A. Clarke, Louis Morse, Oren C. Devereux, Walter C. Burdick, James Campbell, John P. Bonnett, George W. Cheever, F. Parker, A. H. Bliss, E. D. Gilmore, William L. King, J. F. Sturdy, Sylvester Allen, Samuel Allen, J. H. Livsey, Joshua Lathrop, W. A. Engley, Frank Daughaday, E. A. Johnson, Edward B. Hough, John Knox, Edward N. Slade, B. W. Greene, W. W. Fisher, G. H. Niles, E. I. Richards, James N. Hopkins, J. C. Cummings, A. A. Busbee, W. C. Yappan, William H. Mason of JEWELERS' CIRCULAR; Walter Frost and Loomis W. Clarke, *Manufacturing Jeweler*, Samuel Gee, *Providence Journal* and J. N. Hunt, *Evening Telegram*.

The next two hours were delightfully passed in the enjoyment of an excellent menu.

#### The Hearing of A. B. Kapp on His Petition.

PROVIDENCE, R. I., Dec. 29.—The county jail at Howard was the rendezvous Wednesday afternoon for a party of about 30, which included representative manufacturing jewelers, lawyers from this city and New York, and officers of the Manufacturing Jewelers' Board of Trade. The occasion was to attend the hearing of Alfred B. Kapp on his petition to take the poor debtor's oath. Judge George N. Bliss of the Seventh District Court, established court in the prison chapel.

Kapp is the New York jewelry jobber who was arrested in this city about three weeks ago as he was about to leave the State, on a writ charging him with debt, at the instance of R. L. Griffith & Son, of this city. Immediately following this writ, 41 others were served, and Kapp was sent to jail, where his creditors paid his board, amounting to \$126 a week, for a fortnight, when he succeeded in obtaining bail for about \$10,000.

At the hearing Wednesday he stated that he started in business in January, 1892, with a capital of \$3,000 cash and \$2,000 of other resources. On April 9, 1894, he gave a bill

of sale to a cousin, covering all his stock and book accounts, to secure him for certain money that Kapp claimed he had borrowed. His cousin Selig removed the goods to Philadelphia, and for some time Kapp was without employment.

On May 28 the Empire Jewelry Co. were incorporated with a capital stock of \$2,500, three of Kapp's cousins being the stockholders. Kapp was engaged as manager with a salary of \$25 per week. At first Kapp merely countersigned all checks, but lately he has signed and drawn checks without the formality of their being countersigned. The stock with which the Empire Jewelry Co. began business was that which Kapp had transferred by bill of sale to his cousin, and was invoiced to the Empire Co. at \$2,000, and was all the stock that the corporation had.

As the time for the departure of the last train for this city had arrived, the hearing adjourned until Jan. 5.

#### The Suits Over the Stamping of the Word "Rogers" on Silver Plated Ware.

Judge Lacombe, in the United States Circuit Court, Saturday heard arguments on the motion of the Wm. Rogers Mfg. Co., Hartford, Conn., for a preliminary injunction against the R. W. Rogers Co., of Brooklyn and New York, to restrain that company from stamping their corporate name, or the name, "Rogers" on silver plated ware. The plaintiffs, through their attorney, C. E. Mitchell, claimed that in their three trade marks, Anchor, Wm. Rogers & Son, Anchor, Wm. Rogers Mfg. Co. and Anchor, Rogers, Anchor, the name Rogers was a material part of each mark and its use by the defendants was an infringement.

The attorney claimed and quoted decisions to show that his clients, Wm. Rogers Mfg. Co. had an adjudicated title to the name and by these decisions no other firms except Rogers & Bro., Meriden Britannia Co. and Simpson Hall, Miller & Co. had the right to stamp the name "Rogers" on silver-plated ware. He also claimed that the R. W. Rogers Co. were only formed in order that the Niagara Silver Co. or the corporation which they are a part, could have a colorable right to stamp "Rogers" on their goods. His third claim was that the defendant's goods were not of as good quality as those of his clients and did not come up to the standard of the quality they were marked.

The defendant's attorney claimed that there are many corporations to-day using the name "Rogers," and that the decisions quoted by the plaintiffs were only given where fraud had been shown. The R. W. Rogers Co., he said, were formed last August and took the name from the president, R. W. Rogers, who had been connected with the silverware trade for over 15 years. He claimed they had a perfect right to stamp the corporate name on their products, that there was no intent to

defraud the public, that they copied or imitated no labels or marks of any other company and that their goods were equal in quality and in some cases superior to much of the so-called legitimate "Rogers" plated ware.

Catalogues, certificates, advertising signs and silver plated flatware of many manufacturers were introduced in evidence, and the history of the Rogers family was taken up in detail by both sides. Judge Lacombe reserved decision.

A similar motion by the Wm. Rogers Mfg. Co. for an injunction against Wm. A. Rogers, 72 Vesey St., New York, and the R. Wallace & Sons Mfg. Co. who made the goods which were stamped with his name, was argued in the United States Circuit Court before Judge Benedict, on Dec. 24th. No decision has yet been given.

#### Providence.

Henry Reuss has started in the retail business at 680 Potter's Ave.

J. Schwartz, Philadelphia, was in town the past week, calling on the manufacturers.

Wallace & Simmons have transferred real estate in Warwick to Lydia A. Peckham.

G. E. Luther & Co. have removed from 95 Pine St. to the new Kent & Stanley Co. building.

Levi B. Darling is building an addition to his refining and smelting plant at 79 Sabin St.

Mr. Stone, of Stone Bros., New York, visited the manufacturers in this vicinity the past week and placed several good orders.

William P. Rockwell, formerly in the local office of Bruhl Bros. & Co., has severed his connection with that concern, and is now engaged as salesman with E. L. Spencer & Co.

Hon. Thomas Davis, of the old time manufacturing jewelry firm of Sackett, Davis & Co., celebrated the 88th anniversary of his birth on the 19th inst. He is enjoying remarkably good health.

#### Indianapolis.

A fire at New Carlisle, Ind., burned out jeweler Chas. L. Turner.

J. H. Durango, Dunkirk, Ind., was recently bought out by Ed. C. Miller, who will conduct a first class jewelry store.

Retail jewelers all report a very satisfactory holiday trade. Many merchants report sales greater than they had dared to anticipate.

Jeweler J. C. Sipe entertained his clerks at a dinner at the Bates House, Christmas evening. The host placed under each plate a ten dollar gold coin.

Early birds after Indianapolis worms were: Mr. Bigney, S. O. Bigney & Co.; Mr. Fisher, J. M. Fisher & Co.; M. L. Jacoby, Providence Stock Co.; Mr. Sheriden, Horton, Angell & Co.; Chas. Marsh, C. A. Marsh & Co.; Everett J. Rogers, Parks Bros. & Rogers.

## News Gleanings.

Nowlan & Co., Richmond, Va., will enlarge their business.

Geo. E. Bemis, Charlemont, Mass., has removed into his new business block.

After Jan. 1st J. D. Sallade, Norristown, Pa., will greatly increase his business facilities.

E. G. Nealy, Jericho Center, Vt., has located his jewelry business at F. A. Stiles' residence.

G. E. Slaughter, Colton, Cal., has returned from Idaho and advertises his business for sale on account of ill health.

The partnership existing under the firm name of C. Loudon & Son, Gorham, N. Y., has been dissolved by mutual consent.

John Sheedy, a clockmaker, of Lockport, N. Y., was killed Christmas night on the Ligonier railroad near Bell Station, Pa.

A young man named Rice, from Landisburgh, Pa., has opened a watch and clock repair establishment in O. D. Wingert's store, Newport, Pa.

The jewelry store of March & Henwood, 35 Court St., Binghamton, N. Y., was damaged by fire Dec. 26, to the extent of \$10,000; insurance, \$5,000.

American Watch Co., of Oshkosh, Wis., with a capital of \$100,000, have incorporated; incorporators, H. C. Parker, George A. Smith and George R. Zelmner.

In a destructive fire Christmas night, in Albany, N. Y., the jewelry store of F. L. Hunke suffered to a considerable extent, his loss being \$500, insurance, \$800.

A. B. Jones has removed from Greenfield, Ia., to Stuart, Ia., where he takes the management of the store of E. V. Boynton, who goes south for the benefit of his health.

John T. Wyse, dry goods and jewelry, Brenham, Tex., has filed a deed of trust, naming Robert Armstrong as trustee, to secure creditors to the amount of about \$21,000; assets about \$50,000.

Mr. and Mrs. W. F. Main, Iowa City, Ia., left Dec. 26 for the east, Mr. Main to transact business in Providence, R. I., and Mrs. Main to visit various points of interest.

Charles Knapp, who recently robbed the jewelry store of C. Van Derelsen, Green Bay, Wis., was sentenced to two years and six months in the Waupun penitentiary.

Fred. Hobson, a graduate of the Waltham Horological School, Waltham, Mass., is calling on old friends in that city before locating in the jewelry business in New Britain, Conn.

The jewelry store of Mrs. N. J. Bennett, Wellsboro, Pa., was closed by the sheriff recently, executions amounting to nearly \$2,000 having been issued. The stock was sold by the sheriff last Saturday.

On the night of the 14th inst. burglars entered the store of W. W. Viser & Son,

Madisonville, Tex., and stole jewelry of the value of \$250. Also the same night the shop of W. White, jeweler, was relieved of half a dozen watches.

Albert Barnes, a colored jeweler of Fort Worth, Tex., was arrested last week on a charge of theft. Barnes has been one of the leaders of colored society and his arrest has created considerable excitement in the circles in which he moved.

James Derby, jeweler and watchmaker, 1511 W. Baltimore St., Baltimore, Md., was buried on the afternoon of Dec. 24 in the Western Cemetery. The pallbearers were: Dr. J. S. Geiser, Dr. N. C. Mules, T. J. Ways and B. F. Hunt.

F. S. Stahl, Milwaukee, Wis., has made a voluntary assignment to Henry J. Gielens. The assignee's bond of \$500 is signed by Lawrence Ward and John F. Mackenheide. F. S. Stahl is manager of the Stahl Jewelry Co., who are in business on Chestnut St.

A couple of dusky skinned sharpers were in Burlington, Ia., last week, and attempted the theft of a watch at Carpenter's, an article of jewelry at Waldin's, and succeeded in getting away with a diamond ring for which they substituted a glass sparkler at Shontz's.

At the Richelieu Hotel, Phoenix, Ariz., a piece of onyx, representing an alligator, is on exhibition, which was recently carved by a convict in the Yuma prison. It is represented as sitting on the banks of the Ganges, chewing an Hindoo infant, and is surrounded by tortoises and India food fishes.

An unknown man stole two watches from Kraft's jewelry store, Johnstown, Pa., while examining the articles and disappeared. The watches were valued at \$70 each. Mrs. Kraft, the wife of the jeweler who was in attendance, was compelled to keep quiet by the thief pushing a large revolver into her face.

A fashionably dressed lady entered a Davenport, Ia. jewelry store last week and asked to see some diamond rings. She could find no ring that pleased her fancy and left without making a purchase. The next morning when the firm was sorting over the tray of diamond rings the discovery was made that the most valuable ring in the tray was gone, and in its place a piece of glass mounted in a brass ring, probably worth 5 cents.

Christmas night the jewelry store of George Bollinger, Woodland, Pa., was robbed of nine watches, a lot of chains and a number of other articles, also a satchel of ewelers' tools, the whole valued at \$400. C. McCondy was suspected, as he was seen leaving town toward Clearfield. He had been here several days ostensibly to buy out another jewelry store. A warrant was issued and he was arrested with all the goods in his possession. McCondy was held in \$1,000 bail and taken to Clearfield jail.

## Newark.

Harry Ingram, who has been connected with Alling & Co. as traveler for many years, has been admitted as a partner in the firm of A. Joralemon & Co.

The firm of Corey & Osmun have dissolved, Mr. Corey continuing in business with his brother, and Mr. Osmun starting in business with Mr. Parker, of Riker Bros.

Andrew Hatfield, aged 20 years, employed by the Hayden Mfg. Co., was arrested last week, charged by Frank R. Wiley, the manager of the company, with taking the pay envelope of another employe, which contained \$111 more than Hatfield should have received.

## Boston.

### TRADE CONDITIONS.

The holiday trade this year has been more than satisfactory to most of the Boston jobbers. The retailers, too, say that they have done a much better business for the month of December than they anticipated. On the whole, therefore, the jewelry trade in this section looks forward to stocktaking in a very cheerful frame of mind.

The wedding of M. Myers, the material jobber, to a lady of Augusta, Ga., took place, Dec. 27, in that city.

William H. N. Pratt, formerly of the firm of Floyd, Pratt & Co., has connected himself with the William H. Wood Engraving Co., 37 Temple Place, as treasurer and general manager.

The stock of the Craighead & Kintz Co., consisting of piano and banquet lamps, onyx tables and pedestals, bronzes and bric-à-brac novelties, is being sold out at auction under the direction of the Boston jobbers who were the receivers, pursuant to an order of the court.

It is 50 years since the Dennison Mfg. Co. were founded, and they have just celebrated the anniversary by distributing among their employes a fund which the stockholders authorized to be used for this purpose. The distribution was on the basis of \$5 for each year's service, and some of the employes received, it is said, \$150 apiece, as a Christmas present. It is estimated that the whole amount distributed by the company was about \$33,000.

## Rockford.

The Rockford Watch Co. have shut down for two weeks.

Shumway & Carpenter opened their new jewelry store in time for their share of the holiday trade.

Emil Haeni, formerly of this city, who recently failed at Kaukana, Wis., will return to Rockford.

The Rockford jewelers in interviews in a local paper state that their holiday trade was the best in years.

Secretary Kelley, of the Rockford Silver Plate Co., paid the employes half a week in advance so that they could enjoy Christmas.

# CLASSIFIED INDEX TO ADVERTISEMENTS.

All Advertisements are entitled to one insertion under proper heading. Extra insertions, \$6.00 per annum.  
Extra Headings, \$12.00 per annum.

<b>Art Pottery, Bric-a-brac, Etc.</b>	Page.	<b>Diamond Polishing Mills.</b>	Page.	<b>Show Cases.</b>	Page.
Bing, Ferdinand & Co., 106 Grand St., N. Y. . . . .	36	Arthur Co., The, 86 John St., New York. . . . .	39	Smith, B. & W. B., 220 W. 29th St., N. Y. . . . .	40
Straus, L. & Sons, 42 to 48 Warren St., N. Y. . . . .	35	<b>Fine Stationery.</b>		<b>Silver Plated Ware.</b>	
<b>Assayers &amp; Refiners.</b>		Parsons & Greene Co., 18 Murray St., N. Y. . . . .	5	Pairpoint Mfg. Co., New Bedford, Mass. . . . .	5
U. S. Smelting & Refining Works, 25 John St., N. Y. . . . .	40	<b>Gold and Rolled Plate Jewelry.</b>		The Wm. Rogers Mfg Co., Hartford, Conn. . . . .	36
<b>Auctioneers.</b>		Foster & Bailey, Providence, R. I. . . . .	3	Webster, G. A., Chicago, Ill. . . . .	29
Boyle, Davis & Goodman, 63 5th Ave., N. Y., 611 Pennsylvania Ave., Washington, D. C. . . . .	36	<b>Gold Jewelry.</b>		<b>Sterling Silver Novelties.</b>	
Comrie, A. J., 22 John St., N. Y. . . . .	35	Aikin, Lambert & Co., 19 Maiden Lane . . . . .	2-39	Coding Bros. & Heilborn, North Attleboro Mass. . . . .	35
H. M. Rich & Co., 21 School St., Boston, Mass. . . . .	35	Carter, Sloan & Co., 15 Maiden Lane, N. Y. . . . .	15	Holmes & Edwards Silver Co., Bridgeport, Conn. . . . .	10
<b>Badges, Medals, Etc.</b>		Cross & Beguelin, 17 Maiden Lane, N. Y. . . . .	34	Hagan, White & Co., 243 W. 23d St., N. Y. . . . .	39
Stockwell, E. R., 19 John St. N. Y. . . . .	5	<b>Gold and Silver Novelties.</b>		Kent & Stanley Co., Providence, R. I. . . . .	8-9
<b>Book Marks, Sterling Silver and Gold.</b>		Waite, Thresher Co., Providence R. I. . . . .	12	Knowles, J. B. & S. M. Co., Silversmiths' Hall, Union Square, N. Y. . . . .	35
Stone Bros., 535 Broadway, N. Y. . . . .	39	<b>Horological Schools.</b>		Reed & Barton, 37 Union Square, N. Y. . . . .	20
<b>Chains.</b>		Parson's School for Watchmakers, Peoria, Ill. . . . .	29	<b>Sterling Silverware.</b>	
Kent & Stanley Co., Providence, R. I. . . . .	8-9	Philadelphia College of Horology, 623 Heed Building, Phila., Pa. . . . .	39	Fuchs, Ferd. & Bros., 808-810 Greenwich St., N. Y. . . . .	39
<b>Chronometers, Marine.</b>		<b>Jewelry, Silverware and Optical Cases.</b>		Towle Mfg. Co., Newburyport, Mass. . . . .	36
Heinrich, H. H., 14 John St., New York . . . . .	2	Steinhaus, T. C., 10 Maiden Lane, N. Y. . . . .	38	Wallace, R. & Sons Mfg. Co., 3 Park Place, . . . . .	6
Bliss, John & Co., 129 Front St., N. Y. . . . .	38	<b>Jobbers, Watches, Diamonds, Etc.</b>		Wood & Hughes, 16 John St., N. Y. . . . .	39
<b>Clocks, French, English and American.</b>		Allen, Benj. & Co., Chicago, Ills. . . . .	29	<b>Watchmen's Time Detector.</b>	
Evans, W. F. & Sons, Hendsworth, Birming- ham, England. . . . .	4	Aikin-Lambert Jewelry Co., 19 Maiden Lane . . . . .	2-39	I. Imhauser, 206 Broadway. . . . .	5
Jacques, Chas., Clock Co., 22 Cortlandt St., N. Y. . . . .	40	Myers, S. F. & Co., 48 Maiden Lane, N. Y. . . . .	40	<b>Tissue Paper.</b>	
Self-Winding Clock Co., 26 Broadway, N. Y. . . . .	40	<b>Musical Boxes.</b>		Dexter, C. H., & Sons, Windsor Locks, Conn. . . . .	2
<b>Cut Glass.</b>		Jacot & Son, 39 Union Square, N. Y. . . . .	35	<b>Tortoise Shell Goods.</b>	
Clark, T. B. & Co., 860 Broadway, N. Y. . . . .	39	<b>Ophthalmic College.</b>		Potter, W. K., Providence, R. I. . . . .	5
<b>Diamond &amp; Precious Stone Importers.</b>		St. Louis Ophthalmic College, St. Louis, Mo. . . . .	29	<b>Tool Manufacturers and Dealers.</b>	
Cottier, C., & Son, 14 Maiden Lane, New York . . . . .	40	<b>Optical Goods.</b>		Allen, Benj. & Co., Chicago, Ill. . . . .	29
Disselkoen, John N., 19 E. 16th St., N. Y. . . . .	15	Geneva Optical Co., Chicago, Ills. . . . .	29	American Watch Tool Co., Waltham, Mass. . . . .	38
Falkenau, Oppenheimer & Co., 40 Maiden Hedges, Wm. S. & Co., 170 Broadway, N. Y. . . . .	14	Queen & Co., Philadelphia, Pa. . . . .	39	Moseley & Co., Elgin, Ill. . . . .	29
Kahn, L. & M. & Co., 172 Broadway, N. Y. . . . .	40	Spencer Optical Mfg. Co., 15 Maiden Lane, N. Y. . . . .	13	Mossberg Wrench Co., Attleboro, Mass. . . . .	2
Kipling, R. A., Hays Bldg., N. Y. . . . .	14	<b>Pens, Pencils, etc.,</b>		Oliver, W. W., Buffalo, N. Y. . . . .	40
Randel, Baremore & Billings, 29 Maiden Lane . . . . .	15	Aikin, Lambert & Co., 19 Maiden Lane, N. Y. . . . .	2-39	<b>Trunks and Traveling Bags.</b>	
Smith, Alfred H. & Co., 182 Broadway, N. Y. . . . .	14	<b>Photo-Miniature.</b>		Crouch & Fitzgerald, 161 Broadway, N. Y. . . . .	35
Tannenbaum, L., & Co., cor. Maiden Lane and Nassau St., N. Y. . . . .	23	Favre Leon, 107 East 26th St., N. Y. . . . .	40	<b>Watch Manufacturers.</b>	
<b>Diamond Cutters.</b>		<b>Ring Makers.</b>		Trenton Watch Co., Trenton, N. J. . . . .	7
Fox Bros. & Co., 68 W. 4th St., Cincinnati, O. . . . .	29	Bowden, J. B. & Co., 192 Broadway, N. Y. . . . .	4	<b>Watch Case Manufacturers.</b>	
Oppenheimer Bros. & Veith, 35 Maiden Lane, N. Y. . . . .	2	Woods, J. R. & Sons. . . . .	5	Wadsworth Watch Case Co., Newport, Ky. . . . .	31
<b>Diamond Jewelry.</b>		Jones & Woodland, 49 Chestnut Street, New- ark, N. J. . . . .	11	<b>Watch Case Repairers.</b>	
Keller, Ettinger & Fink, 24 John St. . . . .	38	<b>Safes.</b>		The Planchamp & Becker Co., Chicago, Ill. . . . .	29
Schroder, D. & Co., 252 Race St., Cincinnati, O. . . . .	31	Mosler, Bahmann & Co., 518 B'way, N. Y. . . . .	35	<b>Watch Importers.</b>	
		<b>Sample Trunks.</b>		Hyde's, J. E., Sons, 22 Maiden Lane, N. Y. . . . .	38
		Crouch & Fitzgerald, 161 Broadway, N. Y. . . . .	35	Robert, Edmond E., 21 Maiden Lane, N. Y. . . . .	38
				Mathey Bros., Mathez & Co., 21 & 23 Maiden Lane, N. Y. . . . .	39
				<b>Watch Keys.</b>	
				Clark, A. N., Plainville, Conn. . . . .	40

## Special Notices.

Rates 75c. per insertion for notices not exceeding 3 lines (25 words); additional words 2 cents each. If answers are to be forwarded, postage stamps must be enclosed. Two insertions, 15 per cent. off; three insertions, 20 per cent. off; four insertions or more, 25 per cent. off. Payable strictly in advance. Display cards on this page will be charged at \$2.00 per inch for first insertion, subject to same discount as above for subsequent insertions.

Under the heading of **Situations Wanted** on this page advertisements will be inserted for **One Cent a Word**. This offer refers to **Situations Wanted only**. Payable strictly in advance. If answers are to be forwarded, postage must be enclosed.

## Situations Wanted.

*Notices under this heading ONLY are charged at one cent a word, payable strictly in advance. If answers are to be forwarded, postage must be enclosed.*

**WANTED**, a position as salesman, after Jan. 1st, in a wholesale or retail jewelry business, by one who is at present engaged with one of the leading jewelry firms in this city. Best of references given. Address A. A. X., care JEWELERS' CIRCULAR.

**WANTED**, by a practical jeweler. Experienced foreman and designer, especially diamond work, wishes a position by Jan. 1st. Address A. B., care JEWELERS' CIRCULAR.

**TO MANUFACTURERS**.—Situation wanted as traveler; either silver goods or gold jewelry. Ten years' experience in retail store. References. Address B. D. S., care JEWELERS' CIRCULAR.

**WANTED**, to finish trade, 3 years' experience. Best of references. Address T., care of John Burgess, Bloomfield, Iowa.

**SALESMAN**.—A first-class man, with unquestionable references as to ability, character, &c., direct from one of the largest houses in N. Y. city, desires an engagement to travel in New England, New York city and near-by towns. Would like line of fine gold jewelry or any manufacturer's line. H. J., JEWELERS' CIRCULAR.

**A THOROUGHLY** experienced watchmaker seeks engagement. City or country. First-class on watches, plain and complicated. No engraving. Address Garnish, 1313 Third Avenue, New York.

**A PRACTICAL** watchmaker and jeweler, with some capital, wishes a position as manager or partner in a first-class retail jewelry store. Address O. G. N. T., care of JEWELERS' CIRCULAR.

**FIRST-CLASS** watchmaker, 18 years' experience in fine and complicated work and adjusting of high grade watches, desires permanent position with important firm, appreciating good work. High wages expected. Address Adjuster, care of JEWELERS' CIRCULAR.

**A FIRST-CLASS** watchmaker would like position after January 1st. Full set of tools. References if required. Address Whitcomb, care of JEWELERS' CIRCULAR.

**WATCHMAKER**.—First-class all-around man. Twelve years' experience. Full set of tools. A I references. Salary, \$20 per week. Address S., 145, care of JEWELERS' CIRCULAR.

**FIRST-CLASS** watchmaker wants permanent situation with good house. Full set of tools. A I references. Address W., 755, care of JEWELERS' CIRCULAR.

**BY** first-class watchmaker and engraver. Competent to take full charge. Moderate wages. Address Parker, Lock Box 401, Madison, Ohio.

**YOUNG** man (age, 22) wishes any kind of position in jewelry or silverware business. Excellent references. Address H., care of JEWELERS' CIRCULAR.

**A TRAVELING** salesman of nine years' experience will be open for an engagement Jan. 1. Acquainted with the trade in New England, New York State, Pennsylvania and the south; A I references. Address B. M., Box 1276, New York.

**HAVING** an extended acquaintance with both the wholesale and retail trade throughout the west, I should like to form a connection with some manufacturing jeweler as traveling salesman; fine goods preferred; salary moderate. Address Traveler, care JEWELERS' CIRCULAR.

**WANTED**—A position by a married man; age 35; has had seven years' experience in retail, eight years traveling; A I salesman; prefers New York City or near by trade; reference guaranteed. A., care JEWELERS' CIRCULAR.

**WANTED**—A position as representative in New York City and neighborhood trade; manufacturing jeweler preferred; best reference; ten years' experience; salary or commission. H., care JEWELERS' CIRCULAR.

**SITUATION** wanted by watchmaker with local jobbing house; 20 years' experience; A I references; buys \$5-6,000 annually for his trade. S. L., care JEWELERS' CIRCULAR.

**POSITION** wanted by traveler for 1895. Has traveled south and west for the past 17 years. First-class reference. Address S. H., care JEWELERS' CIRCULAR.

### EXPERIENCED

## Diamond Cutters and Polishers,

(HOLLANDERS)

wish to work for some first-class jewelers. They are acquainted with every branch of the trade and are willing to work in any city in the United States.

Address, A. P., care JEWELERS' CIRCULAR.

## Help Wanted.

**A TRAVELING** salesman to handle a first-class line of jewelry on commission in New York State, Pennsylvania, Ohio, or any one or two of the three, calling on the legitimate jewelry trade only in connection with his present line. Address T. 74, care JEWELERS' CIRCULAR.

**WANTED**, good engraver, who can assist watchmaker when not busy engraving, for leading store in the southwest. Address, giving age and salary wanted, S. Charles, P. O., Memphis, Tenn.

**WANTED**—A TRAVELER WELL ACQUAINTED WITH NEW ENGLAND JEWELRY TRADE. ONE WHO HAS HANDLED SILVER PLATED WARE. ADDRESS M., CARE JEWELERS' CIRCULAR.

## For Sale.

**A GOLD** solder that has a 14 kt. color, will not tarnish with perspiration, and will flow on silver. Send 25 cents for sample of (the best of all gold solder), 50 cents per dwt. Address J. J. Kerr, Manufacturing Jeweler, Indiana, Pa.

## Miscellaneous.

**I BUY JEWELRY STOCKS**—Manufacturers, jobbers and retailers desiring to dispose of surplus or entire stocks of diamonds, watches and jewelry, can find quick cash buyer by addressing Oscar Langer, 176 Broadway, Room 58½, or 223 E. 71st St., New York.

## Business Opportunities.

**WANTED**. Partner, with some money, in successful, established engraving business. Will be taught the trade, if desired. Best references given and asked. Large profit on investment assured. Address Engraver, A. B. C., care of JEWELERS' CIRCULAR.

## WHEEL CUTTING.

We make a specialty of Wheel Cutting, Demagnetizing and Watch Repairing for the trade. Complete plant. Send for price list.

**THE WINSLOW & PENNEY CO.**  
608 Masonic Temple, - CHICAGO.

## Frederick Knupfer the Victim of Assault and Robbery.

The store of Frederick Knupfer, retail jeweler, 206 Varick St., New York, was entered Thursday afternoon and the best part of his stock, together with a quantity of jewelry and watches left for repairs, was stolen. Although this happened shortly after 2 o'clock in the afternoon, on a crowded street and in sight of many persons, the thief or thieves has not yet been captured. This was the second attempt made to rob the store within a week. Knupfer is an old man and a German, and is a practical jeweler and watchmaker.

On Christmas Eve, Knupfer narrowly escaped death by assault. While waiting on a young man who wished to look at some watch chains Knupfer was struck upon the head with a piece of pipe in the hands of the pretended customer. Fortunately he did not lose consciousness and his cries made the thief drop his plunder and escape. Thursday afternoon Knupfer closed his store at 2 o'clock and went out for his lunch. When he returned 15 minutes later he discovered the glass panel of the door had been broken in and his store virtually "cleaned out."

Mr. Knupfer, when seen by a CIRCULAR reporter, was heartbroken by his misfortunes. His loss, he said, was only about \$300, but it was all he had in the world and beside his business was now ruined, for since these two bold attempts at robbery, customers were afraid to send jewelry for repairs, thus cutting off his only means of making a living.

Mr. Knupfer lays his trouble to the doors of the police. While working in a jewelry store on the Bowery, which, he says, was only a blind to hide a gambling establishment, he gained the enmity of the police of the Eldridge St. station who frequented the place. Since that time, Knupfer says he has been hounded everywhere he went, and the thieves and toughs of his neighborhood knowing the feeling of the police and their apathy to do him justice, have made him their mark.

Eric Skamser, Buckley, Wash., recently gave a bill of sale to J. B. Dinkenspeil & Co., San Francisco, Cal.

## TO OPTICIANS.

I am the originator of several optical illusion cards which are trade winners. Only sold to one optician or jeweler in each town or city. Prices to the trade on application. First come first served.

**WM. M. UPDEGRAVE,**  
242 Main Street, Johnstown, Pa.

Will Sell Elegant Stock of  
**Finest Jewelry**  
(nearly new) inventoried at \$16,-000, at a liberal discount, C.O.D. Address Cash, care Jewelers' Circular, N. Y.

THE STAR OF EMPIRE WESTWARD TAKES ITS WAY

# WESTERN SUPPLEMENT

## of THE JEWELERS' CIRCULAR

Chicago Office: Room 517, Inter-Ocean Building.

VOL. XXIX.

CHICAGO, WEDNESDAY, JAN. 2, 1895.

NO. 23.

### Chicago Notes.

M. H. Kennedy is a new house in Parsons, Kan.

W. E. Jenkins spent the holidays in Vincennes, Ind.

Jobbers are still receiving good sized mail orders.

T. A. Haney, lately of Lyons, Kan., has opened in Springfield, Mo.

J. M. Sullivan has just opened a jewelry business in Wheatland, N. Dak.

Mr. Crawley, manager here for Adolphe Schwob, left Friday on a New York visit.

C. S. Poole, formerly of Anthony, Kan., has established an elegant store in Joplin, Mo.

Engravers are as busy as previous to the holidays, principally on fine goods that require careful work.

Ostby & Barton Wednesday brought suit in assumpsit for \$600 against Fred, Lemendt, in the Superior Court.

George Gubbins, formerly with H. Muhr's Sons, will travel after Jan. 1 for the Courvoisier-Wilcox Mfg. Co.

Manager Weidig, of Jos. Fahys & Co.'s Chicago office, is on a ten days' to two weeks' visit in New York.

There is no change in the condition of Frank Strohm, 2821 Archer Ave., recently afflicted with paralysis of the legs.

J. L. Sievert, formerly of Fulton, Mo., recently moved to Springfield, Mo., and is making a specialty of optical goods.

Manager Loeb, of the Chicago office, left for the Wadsworth Watch Case Co.'s factory Thursday night, to be absent a week.

Mr. Bassett, of Bassett & Fairbanks, Jacksonville, Ill., visited the silver houses last week, likewise J. H. Reed, of Bloomington, Ill.

Isaac Swope, the watch case manufacturer of St. Louis, genial, hale and hearty as ever, made a flying trip to visit his Chicago friends last week.

There is a feeling among watch men and case dealers that business will pick up quickly and that houses will commence buying very soon after the first.

Outside retailers, those in outlying portions of the city, report a better business than December a year ago and the improvement seems to be universal.

Manager Caldwell, Rogers & Hamilton Co. will leave for the factory about Jan. 5, for a 10 days' visit there, and a few days with his mother at Baltimore.

L. Solomon, representative here of Leon Hirch, Swiss watches, left for New York Friday. It is understood the Chicago office, 155 State St., will be discontinued.

Cox & Nottensmeyer, Mt. Vernon, Mo., have recently bought out B. R. Peden, of that place. Mr. Peden retires from jewelry to engage in the optical business.

Manager T. H. Purple, Holmes & Edwards Silver Co. and Manhattan Silver Plate Co., returned Friday from a Christmas visit to his home in Constantine, Mich.

"The finest store in the State" is the claim put forth in behalf of H. W. W. Starcke, Junction City, Kan. Mr. Starcke has moved into his new store on the main street.

G. W. Marquardt & Sons state they are doing considerably more than they expected after the holidays, but give no reason for the large volume of jewelry orders.

John Gilles, Fort Scott, Kan., formerly with Harry F. Legg, Minneapolis, has fitted up a nice store in the former place and is receiving much encouragement from his business.

Manager Kettle, of the western office, accompanied President Fitch, of American Waltham Watch Co., on the latter's return trip. Mr. Kettle will divide his visit between New York and Philadelphia.

"Business kept right up to the last minute and good orders are still coming in," said Mr. Eaton, for D. Wilcox & Co., 407 Columbus building. "The sale of fancy rings has been unusually large."

C. F. Coutts, representative of G. A. Webster, is spending two weeks with his family in Clarksville, Tenn. It is antici-

pated the family will accompany him on his return and make this city their home.

C. W. Harmon, of the New York office of Jos. Fahys & Co., stopped over Thursday and Friday at the Chicago office. Mr. Harmon is accompanied by his wife, and is on his way to visit in California.

The office formerly occupied by H. Muhr's Sons, was vacated Thursday. The stock and fixtures had previously been disposed of and the books were shipped to Philadelphia, Friday, winding up affairs at the western office.

\* Manager Dorrance, of Simons, Bro. & Co.'s Chicago house, left Jan. 1st to attend the annual travelers' meeting of the firm in Philadelphia, which opens Jan. 2d and continues 10 days. At this function all the wares of the company are displayed and discussed by the practical men present and plans for the coming season talked over.

Goldsmith Bros., refiners and smelters, 65-67 Washington St., will double their office facilities Feb. 1, taking possession of the entire fourth floor. This increase was necessitated by the rapidly enlarging business of the firm and will be a great convenience to their many patrons. The firm report shipments coming in large and increasing volume.

The invitations to the Chicago Jewelers' Association banquet have been received from the printer and are a fine sample of press work—Italic script on heavy plate paper. The sub-committees on speakers, printing and toasts have not yet completed their work, but it is in the hands of competent men, as follows: Speakers—Messrs. Talbot, Hahn and Todd; printing—Messrs. Sercomb, Todd and Talbot; toasts—Messrs. Sackett, Sercomb, Hahn and Byrne. Rosenbecker's orchestra and the Imperial Quartette will furnish the musical numbers for the jewelers' gala night, Jan. 24, at Kinsley's.

THE CIRCULAR is the *Best* paper on the market and cannot be without it.

R. J. TRUMBULL, What Cheer, Ia.



# LOOK AT THESE PRICES!

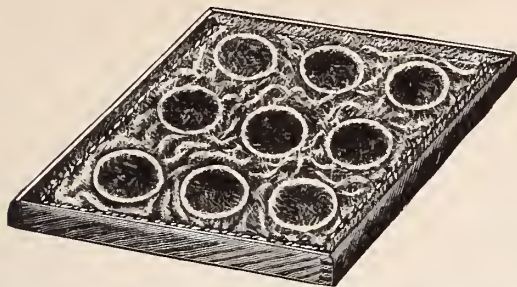

Show Case Trays with Solid Walnut Frames lined with fine Red Silk Plush, with Old Gold Border, and made to stack one on top of the other. Size, 11 3/4 x 11 3/4.

For Gents' Watches, each. . . . . \$1.25  
For Ladies' Watches, each, . . . . . \$1.25  
For Rings, each . \$1.25. For Chains, each, . \$1.25  
For Charms, ea., \$1.25, for Card Jewelry, plain, ea., 80c.

Subject to the usual discount for cash.

## CHRISTMAS IS COMING.

Make your Stock Attractive and Fresh. It does not cost much and will add largely to your SALES.

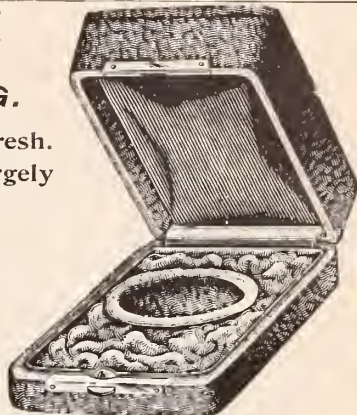

FINE PLUSH BOXES.

### BENJ. ALLEN & Co.,

141 & 143 State St.,  
CHICAGO, ILL.

WATCHES, CLOCKS,  
DIAMONDS,  
SILVERWARE  
and JEWELRY.

For Gents' Watches, per dozen, \$3.00  
For Rings, per dozen, . . . . . \$2.00  
For Six Tea Spoons, per dozen, \$9.00  
For Child's Set, per dozen, . . . . \$9.00  
For Sugar Shell, per dozen . . \$9.00  
For Ladies' Watches, per dozen, \$3.00  
For Ear Drops, per dozen, . . . \$1.50  
For Six Table Spoons, per dozen, \$15.00  
For Six Coffee Spoons, per doz., \$15.00  
For Butter Knife, per dozen, . \$9.00

Subject to the usual discount for cash.

DON'T FORGET THE JEWELERS' CIRCULAR PUBLISHING CO.'S BOOK LIST when in want of any technical book in the Jewelry or Kindred Trades.



## GENEVA OPTICAL CO.,

CHICAGO.

CATALOGUES.

- PART 1—General Catalogue of Optical Goods.
- " 2—Microscopes and Accessories.
- " 3—Photographic Cameras, Stocks and Supplies.
- " 4—Thermometers, Barometers and Meteorological Instruments.

**PRESCRIPTION WORK** Made with Promptness and Accuracy.

**OCULISTS' or OPTICIANS' OUTFITS.** Trial Cases, Ophthalmoscopes, Lens Measures.

CORRESPONDENCE SOLICITED.

**W. J. LAMONT**  
Makers and Repairers of  
**WATCH CASES**  
Gold and Silver Plating  
— of Watch Cases a Specialty  
UNEXCELLED FACILITIES

83 and 65 East Washington St., Chicago



One of the best of the very best.

QUALITY IS THE STANDARD OF VALUE FOR WHICH WE COMPETE

"THE MOSELEY."

"A Bread Winner" for the watchmaker. We furnish you good lathes and chucks, while the other fellow furnishes the wind.

MOSELEY & CO., Elgin, Ill.



No. 2 Moseley Wire Chuck has length, strength, accuracy.

## The St. Louis Ophthalmic College and Hospital

A SCHOOL OF THEORETICAL AND APPLIED OPHTHALMIC OPTICS.

1655 SOUTH JEFFERSON AVENUE,

N. W. Corner Lafayette Avenue, ST. LOUIS, MO.

For the Announcement and further information, address Ignatz Mayer, M. D., President.



**PARSONS' SCHOOL**  
—FOR—  
**WATCHMAKERS,**  
**PEORIA, ILL.**

Send for Circular and Terms

**PARSONS & CO.**

**G.A. WEBSTER**

42 & 44 Madison St., Chicago, Ill.

**Manufacturer,**

AND WESTERN AGENT FOR

E. G. WEBSTER & SON, of Brooklyn, N. Y.

A. F. TOWLE & SON CO., of Greenfield, Mass.

## THE SPECIAL

COLUMNS

— OF THE —

## Jewelers' Circular

Bring Better Results for a Small Outlay of money than any medium in the Jewelry Trade.

TRY THEM.

THE NOTICE

DIAMOND CUTTERS and POLISHERS looking for desirable and permanent positions should apply direct to

# FOX BROS. & CO.,

68 and 70 West 4th Street,

CINCINNATI, OHIO.

## Cincinnati.

### TRADE CONDITIONS.

Every jeweler in Cincinnati has cause to be satisfied with '94 holiday trade. The weather was "jewelers' weather," warm and pleasant, and every store was crowded up to the last minute. Oskamp, Nolting & Co. had perhaps the most extensive trade in the city. Duhme & Co. had fine sales. As to C. Hellebush, while his sales were not enormous in numbers, they were large in amounts. Gustave Fox & Co. sold one \$1,900 diamond set, and a number of others almost as handsome, besides having minor sales in great numbers. The jobbers also are hearing from the outside trade with much satisfaction, most of the memorandum packages having been sold entire, while many will be held over to the new year.

O. E. Bell & Co. report elegant sales. P. C. Pfaffle has returned from a long trip which was very satisfactory.

Louis Albert, of Albert Bros., says he made a mistake in not buying more novelties in silverware. They had a fine clock sale.

The failure of the Cincinnati Aluminum Co. last week was a surprise to many. Their liabilities will reach \$20,000; assets \$30,000.

Eastern salesmen are beginning to show themselves, but it is too early. Some of the jewelers will begin stocktaking this week.

Homan & Co. are taking stock. Joseph Homan has returned from New York where he has been superintending the outfitting of their eastern salesroom.

Bernard Thelan, a W. 5th St. jeweler, saw a girl pick up ten rings from a tray and followed her home with an officer. As she gave up the articles, he did not prosecute her owing to her youth.

The Cincinnati Wholesale Jewelers' Association held a preliminary meeting, Thursday, and nominated the following, to be elected Jan. 2: President, A. G. Schwab; vice-president, H. C. Walton, of the Wadsworth Watch Case Co.; secretary and treasurer, Jos. Becker, of Jos. Fahys & Co.; board of directors: A. Herman, of D. Schroder & Co.; A. Sanders, of the Denison Mfg. Co. The meeting will be held in the Burnet House, at 7.30 o'clock P. M.

## Kansas City.

Barney Metzgar has given a chattel mortgage for \$3,000.

H. C. McConnell, of C. G. Alford & Co., New York, spent the holidays in Kansas City.

Among the country buyers in town the past week were: J. H. Whitesides, Liberty, Mo.; T. W. Koalsteadt, Pleasant Hill, Mo.

V. G. Cuthbert, with Otto Young & Co., Chicago, remained in the city over Christ-

mas and met several of his country customers who were in town.

W. W. Atkin has opened a jewelry store at 517 Minnesota Ave., Kansas City, Kan. The store will be in charge of J. S. Schick, a competent jeweler. The store has been neatly furnished with new furniture.

The retailers report a larger number of people in town for Christmas than for some years, and the number of sales has been large, but as a rule the more expensive articles have not been bought. Among the wholesale dealers trade has been very good all the Fall, especially from southern Missouri and Oklahoma Territory.

Burglars broke the plate glass show window of I. N. Collins' jewelry store, Cherokee, Kan., and abstracted a quantity of jewelry. The deed was done in the early part of the evening when the streets were crowded with the holiday shoppers, but in the excitement the men escaped. The loss will amount to about \$500.

## Detroit.

Robert Beatty, 548 Baker St., was last week married at Toronto to a California lady.

George L. Lowe has returned from a prosperous trip through upper Michigan for Kennedy & Koester.

Frank Hamilton and wife, Stockbridge, and L. Peabody and wife, Birmingham, spent the holidays in this city.

S. Friedburg, the Ann Arbor jeweler, last week lost his little two year old child. The remains were brought to Detroit and interred in Elmwood cemetery.

F. S. Ring, formerly engaged in the wholesale and retail jewelry business at 68 Woodward Ave., and who has taken a position as business manager of the New Columbus Watch Co., spent the holidays with friends here.

F. G. Smith & Sons, who are preparing to remove their stock to new quarters at the corner of Clifford St. and Woodward Ave. some time in January, have offered the second and third floors of the building to the Board of Education for use during the ensuing year.

The traveling salesmen of the Johnston Optical Co. have been called in. The following will start out again about Jan. 1st: A. E. Southworth, C. M. Scannel, W. B. Gordon and Tom C. Phillips. The company report one of the best holiday trades they ever experienced.

Business in Detroit during the holidays was generally better than was expected. This was true of both retail jewelers and jobbers. The trade was far ahead of that of last year and almost equal to that of two seasons ago. The following Michigan country jewelers were in the city the latter part of Christmas week; William Parke, Reese; J. E. Haep, Montpelier, Ohio; L. A. Stehl, Linden; John T. Eddington, Orion; and A. W. Kludt, Lennox.

## Minneapolis and St. Paul.

### TRADE CONDITIONS.

All the Twin Cities jobbing houses enjoyed a fair Christmas trade, and are now very busy taking their annual inventory. Business was ahead of last year and was very encouraging to the jobbers. The retail trade was also very satisfactory throughout the Twin Cities, and in several cases exceeded the trade for the past two years.

News reached Minneapolis on the 26th inst., that Wm. P. Nesbitt's jewelry store, at Grand Rapids, Minn., was entirely destroyed by fire at midnight on Dec. 24th. The stock was worth about \$2,500; it is not known if insured.

An order was issued Dec. 20th, by the District Court of Hennepin County, in the matter of the assignment of Joseph Dupont, Minneapolis, directing and requiring the assignee to advertise for bids for a portion of the assets of the estate, consisting of counters, show cases, store fixtures, safe and the entire stock of merchandise remaining undisposed of in the hands of the assignee; bids were to be submitted to the court by Dec. 29th, when the estate would be sold to the highest bidder and confirmed by the said court.

## St. Louis.

The Mermod-Jaccard Jewelry Co. reported a daring theft last week. A well dressed young fellow entered the store and asked to see some diamonds. A tray of gems was shown him. He substituted two "phony" stones for the genuine and slipped away with brilliants worth \$800. Edward Eaves was arrested on suspicion, but was released.

L. Bauman Jewelry Co. sued A. Bertig recently for \$500 and interest from Feb. 2, 1894, alleging that Bertig gave the firm an order to allow a jewelry agent named L. Lippman to have goods to that amount. Lippman, they allege, "got in on" the firm to the extent of \$1,371.10, and refused payment. Bertig refused to make good his alleged guarantee.

Gambetta Achard, the son of a prominent French jeweler of this city, was arrested a few days ago on complaint of C. Heetfeldt & Co., diamond setters. It is charged that Achard recently dropped into Heetfeldt & Co.'s shop in order to get a diamond ring he had left for repairs. He got his ring, paid for the repairs and left. Shortly after Achard went out another diamond ring, which was lying on a table in the shop and which is valued at \$250, was missed. Achard was suspected of having nipped this ring, and his arrest was made on this ground.

A delicate and pretty souvenir issued to his friends by J. P. Stevens, of J. P. Stevens & Bro., Atlanta, Ga., is a folding card which on the outer side under an appropriate snow bird design contains his greeting for Christmas and New Year.

**San Francisco.**

Sales during the week preceding Christmas were in small articles, but numerous. One small firm sold over 200 hat pins. It is the talk of the trade that Sareve & Co. carried off about 75 per cent. of the trade in silver articles this Christmas.

A. Green, father of W. A. Green, of Carrau & Green, has returned from a trip to Europe.

M. Wunsch & Co. are selling their large stock at retail in anticipation of retiring from business.

Frank Carter, traveler for Armer & Weinschenk, has severed his connection with that house and has left for the east to secure coast agencies.

Geo. C. Smith, formerly representative of the Keystone Watch Case Co., and now in the mining industry, has accepted a temporary position with Vanderslice & Co.

The charge against L. H. Scharer, jeweler, arrested for violating the ordinance against selling pools on the races, has been dismissed on the ground that the evidence did not justify the charge.

Among the jewelers from the interior who were in town buying goods recently were: J. B. Klune and C. J. Noack, Sacramento; Chas. E. Graebes, San José; C. W. Thompson, Tomales; A. Thurman, Healdsburg; and C. Rappe, Watsonville.

**Tacoma, Wash.**

J. Lawrence has opened a store in Ashcroft, B. C.

Rounsfell & Co. are a new jewelry firm in Wellington, B. C.

V. E. Campbell, Mount Vernon, Wash., has taken quarters in the Mount Vernon drug store.

It is now believed that Simon Rumpf, the absconding Seattle jeweler, is in Honolulu. It is certain that a friend has received a letter from him recently, but refuses to divulge its contents.

Burglars attempted to blow open the safe of J. S. Boyd, Auburn, Wash., recently. Instead of boring a hole the burglars poured powder into the key hole (the safe being of an old pattern). No damage was done, and nothing was abstracted from the safe.

Fred Mathers, a young man, attempted to burglarize the store of C. E. W. Bowers, Seattle, on the night of Dec. 19. Mr. Bowers was engaged in conversation when Mathers entered the rear door and struck Bowers, who had gone to meet him, on the head with a "black jack." The noise alarmed two friends of Bowers in front, who immediately commenced yelling for a policeman. This alarmed Mathers, who ran out of the back door into an alley. A pistol shot scared the young man and he surrendered. He was held for examination. Mr. Bowers' injuries are not serious.

**Pacific Coast Notes.**

G. E. Pruner & Co. opened in Berkeley, Cal., Dec. 17.

Robert S. Norris has bought out G. Nieme, Astoria, Ore.

J. R. Hirsch has opened at 402 S. Broadway, Los Angeles, Cal.

Moore & Co., San Bernardino, Cal., are conducting a special sale.

Eric Skamser, Buckley, Wash., has given a bill of sale of his stock for \$1,500.

A. B. Crawford, Flagstaff, Ariz., has new quarters in the Cook & Lee building.

B. Haas, for 25 years a jeweler of Haywards, Cal., died recently at his home.

Frank Golden, Nevada City, Cal., has opened a branch store in Grass Valley.

Jeweler Lawrence, formerly of Whatcom, Wash., has removed to Ashcroft, B. C.

E. Dobrowsky, Redding, Cal., has remodeled his store in fine style and also increased his stock.

A. Keshishyan, formerly with S. Keshishyan, has opened business for himself on Mariposa St., Fresno, Cal.

The Oakland, Cal., city council has passed an ordinance requiring traveling jewelry dealers to pay a license of \$15 per day.

San Bernardino, Cal., jewelers have followed in line of those of other southern cities and have asked the common council to impose a license of \$25 a day on auctioneers.

A. Stark, of Will & Stark, Albany, Ore., has returned from Chicago, where he graduated from the Chicago Ophthalmic College. This firm have just removed into larger and better quarters.

**THE WADSWORTH WATCH CASE CO.**



774.

General Offices,  
NEWPORT, KY.

Filled



793.

NEW 12 SIZE  
TO FIT ALL 6S. P. S. MOVEMENTS.

Cases.

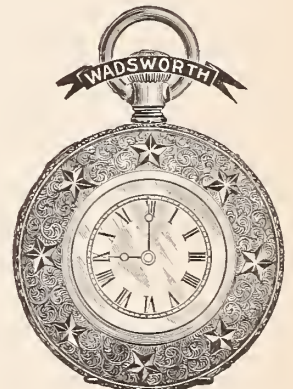

802.

Chicago Office,  
COLUMBUS BUILDING.

**D. SCHRODER & CO.,**

**WHOLESALE JEWELERS  
AND IMPORTERS,**



Diamonds, Loose and Mounted at Big Bargain Prices. Sole Agents for West and South of Howard Watches at Greatly Reduced Prices. Send for our Catalogue, it will please you.

**252 RACE STREET, CINCINNATI, O.**

## Connecticut.

### TRADE CONDITIONS.

J. Otto Schattgen has a new jewelry store in New Britain.

Pierpont, the Naugatuck jeweler, has sold his stock and gone to Arizona to reside.

The late Herman Alderman, jeweler, New Haven, left an estate valued at about \$6,000.

The New Haven jewelers report Christmas sales as in excess of last year's, and this is the case generally throughout the State.

Gilbert Rogers, of C. Rogers & Bros., has been elected president of the Meriden Republican club. N. L. Bradley is one of the club's trustees.

Scovill Hitchcock, the Southington jeweler, has arranged with his creditors on a 20 per cent. basis, and an auction sale of his goods took place last Saturday and Monday.

Nelson S. Bryant, who left Bridgeport Dec. 5th, having issued worthless checks for goods bought of various merchants has determined to pay up and has settled his account with Capron, the jeweler, for an \$85 watch, and with Deveau & Peck, jewelers, for a diamond ring.

Secretary Tibbitts, of Simpson, Hall, Miller & Co., Wallingford, says that the company will not give up having a store in New York, but will secure another location in the city, the place not yet being decided upon. The company's lease of their store on Union Square does not expire until 1898.

The annual meeting of the Simpson, Hall, Miller & Co. Aid Society, Wallingford, was held last Saturday evening and these officers were re-elected: President, John Norton; vice-president, Charles Toothe; secretary, Howard James; treasurer, R. S. Horton; trustees, A. Dickerman, B. F. Williams and C. Toothe. The membership of this society now numbers 90. The dividend declared was \$4.50, leaving a balance of \$2.25 in the treasury.

A. J. Comrie, the jewelers' auctioneer, finished his sale for E. P. Durando & Co., Chattanooga, Tenn., on the night of Dec. 24th. A letter from the firm to Mr. Comrie, of which the following is a copy, is another testimonial of the recipient's ability in his profession:

A. J. COMRIE,

DEAR SIR—At the close of the auction sale to-night we are pleased to return you our thanks, knowing you have done your utmost to get the best possible prices for our goods, and have accomplished the sale perfectly satisfactory to us.

E. P. DURANDO & Co.,  
Chattanooga, Tenn.

Mr. Comrie left Chattanooga for Rochester, N. Y., to finish his sale for H. G. Booth. His next sale will be for the Upson Jewelry Co., Waterbury, Conn., commencing Jan. 2d.

## Trade Gossip.

The trademark of T. B. Clark & Co., 860 Broadway, New York, on cut glass, is a guarantee of quality and selling powers.

The Kent & Stanley Co.'s beautiful factory building still continues to be the subject of compliment and admiration in Providence.

Have you seen the revolving hairpin offered by Paul Jeanne, 220 Fourth Ave., New York? It is highly commended by all to whom it has been shown.

"Quick selling novelties" are the constant aim of Coddling Bros. & Heilborn, North Attleboro, Mass. That they succeed is evidenced by their business.

"When in doubt buy Pairpoint goods;" send for silverware catalogue, No. 10, or cut glass catalogue, No. 11; the Pairpoint Mfg. Co., New Bedford, Mass.

We call special attention to the card of the Holmes & Edwards Silver Co., Bridgeport, Conn., on orange goods. They have a deservedly wide reputation and are being offered at special prices.

Wm. Smith & Co., 5 and 7 Maiden Lane, New York, have always in stock a most complete assortment of gold, silver and roll plate chains and jewelry, gold and silver bead necklaces, lorgnette chains, bracelets and silver rings.

M. Wollstein, 25 John St., New York, is the sole manufacturer of the celebrated Phoenix Flux and Eureka Alloy. Mr. Wollstein makes a specialty of sweep smelting and assaying and pays highest market price for old gold and silver.

Geo. W. Baker, the Providence, R. I., sweep smelter and refiner, whose work gives invariable satisfaction, is making extensive improvements in his plant which will be the subject of more extended mention in subsequent issues.

The R. Wallace & Sons Mfg. Co., Wallingford, Conn., show a constantly augmenting line of sterling silver novelties both for use and ornament. Their page in this issue depicts, as usual, some artistic designs in flasks, ink bottles and paper cutters.

L. Tannenbaum, of L. Tannenbaum & Co., New York, has the courage of his convictions. He says his prices on diamonds and all other precious stones defy competition and stands ready to prove his assertion to every buyer who will favor him with a call.

The Waite, Thresher Co., Providence, R. I., in a most commendable spirit of good fellowship extend to the entire trade a hearty whole souled New Year's greeting. It is intended for you whether your name appears on the firm's books or not, but in the latter case, the prosperity in the greeting will be all the more certain for you if you will handle the Waite, Thresher Co. popular goods during 1895.

In the display page of Foster & Bailey, Providence, R. I., elsewhere in this issue,

dealers will find interesting reading. A perusal of the various lines of goods offered affords some idea of the variety and scope of the firm's business. In the manufacture of sterling silver novelties especially, Foster & Bailey have taken a commanding position; all are guaranteed to be  $\frac{925}{1000}$  fine. Their toilet and manicure goods, too, have attained a deservedly wide popularity.

The leader in jewelers' findings is Thomas W. Lind, Providence, R. I. Mr. Lind's line is most complete as may be inferred from the two mammoth half tone plates showing some of his artistic productions which recently appeared in THE CIRCULAR. Mr. Lind has a staff of competent designers and engravers constantly engaged in evolving new and salable things. Send for his sample sheets and keep them before you for convenience in ordering.

We have already called attention to the merits of the American knife sharpener, made by the Mossberg Wrench Co., Attleboro, Mass. The list of A1. houses from whom the article may be obtained is in itself a guarantee that the sharpener has sterling merits. For table use the sharpener is a handsome article and a most useful ornament. For desk use it will be found excellently adapted for keeping an edge on erasers or pen-knives, while serving as a paper weight.

## Lancaster, Pa.

Retail jewelers of this city all report an unusually heavy and satisfactory Christmas trade.

W. W. Appel, jeweler, announced that he would give a prize of a large music box to the person guessing closest to the number of persons visiting his store on the day before Christmas. There were 3,600 guesses submitted and the upshot has been somewhat of a dilemma. The actual number of persons who visited the store on Monday Dec. 24th, was 1,154, and on examining the guesses it was found that two persons had guessed equally close. B. E. Osgood, 19 Maiden Lane, New York, guessing 1,153 and Mrs. C. E. Rea, of Lancaster, guessing 1,153. Mr. Appel will let these two persons determine for themselves the ownership of the music box.

## Bangor, Me.

Harry F. Hayes, representing a Boston wholesale house, was here last week, calling on the trade.

The jewelers in this city had a very large Christmas business. Some of them say that it eclipsed that of previous years. The trade in sterling silver novelties was immense.

W. C. Bryant has been doing quite an extensive business in badges. He has recently made several for the Masonic order, and has fitted out nearly every policeman in the city with a gold star.

### Curiosities in Night Clocks.\*

WHEN the first timepieces were invented it was thought that they might be arranged so as to be used at night. At the earliest period, when gnomons and sun-dials were the only timepieces, men contrived to note the time at night by means of a plumb-line hung vertically in the direction of the polar star, but this could only answer in the open country and during clear nights. Clepsydræ alone could be

face consists of a plaque on which are two dials showing on a ground in *repoussé*. The inferior dial, in brass, is meant for the daytime. The top one is a disc of glass with hour marks on it painted in black. Almost close behind this disc is another circular glass plate, on which a little figure, also painted in black and holding a stick, serves to point the time. A dented wheel, hidden by the surrounding ornaments, is fixed on to the rim of this second glass plate. This wheel is connected by means

The dial revolves, bringing the marks in turn underneath a dove-shaped motif also in pierced work, placed in the center of the crowning ornament. A lamp rests on the case containing the movement, so that the top hour mark and the dove pointing down to it are only visible in the night. This interesting piece is in polished brass, with the exception of the dial, which is silver plated.

(To be continued.)

### Workshop Notes.

**Drills.**—It is sometimes very troublesome to harden a very small drill as it cools before it can be plunged. I place such a drill between two steel wire jaws, heat them and plunge the whole into whatever I decide to harden it in.

**Repairing.**—Every workman has his favorite way in doing small repairs, such as tightening centers, etc.; there are many ways to do them, all familiar to the average repairer. THE CIRCULAR would say, however, never tighten a center with such a weak device as bristles. A very good way, beside rolling between files, is to lay the carbon pinion in a stake supporting itself by the leaves and strike into the lower end of the hole with a three-way-sharpened piece of hardened steel. This three-way-sharpened punch, also, will tighten a loose table roller.

**Hardening a Drill.**—Balance staffs are usually pretty hard, and oftentimes it is a difficult matter to drill them. I generally use, at first, a drill hardened in the ordinary manner, and if I am unable to make it work, I then try a drill hardened in petroleum, which will generally harden it sufficiently; but should that, too, prove ineffectual, I use one hardened in mercury, which will produce the hardest kind of a drill. I use the latter as a last resort, however, as they are rendered very brittle, and a small drill is liable to break off in the hole.

**Lubrication.**—Concerning the relative importance and effect of the quantity of oil used for lubricating a watch it may be stated in a general way that neither too much nor too little should be given. If there is too much oil, the excess will "get the better," as it were, of the capillarity; in other words, it will run off and carry the necessary lubricant with it, and there will be a certain amount of wear by friction. The superabundant oil will spread over other parts only to the injury of, and prove as an obstacle to, the time-keeping qualities of the watch. The great aim of the watchmaker should be to bring all the different parts of the watch into one harmonious whole, but at the same time not to lose sight of auxiliary matters. It very often happens that the best watch does not go as it might, owing entirely to the action of the oil, and the watchmaker should always be on the lookout for a good oil, that will not rust, run or leave its place.

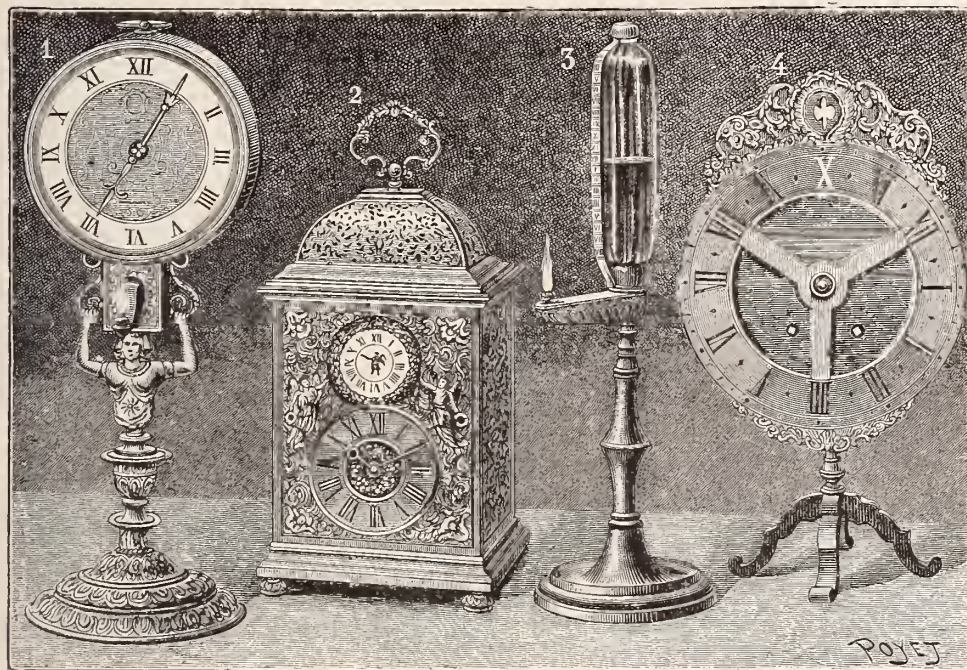

GROUP OF CURIOUS NIGHT CLOCKS.

used in the houses; accordingly contrivances were devised so as to light them at night. A clepsydra provided with a lamp is mentioned in the Tchan-li, a Chinese book written 202 years B. C. An Arabian clepsydra, which could be seen in a Damascus mosque in 1184, was made to answer the same purpose.

Many night clocks have been produced from the sixteenth century down to our times. To describe some curious specimens in this line is the object of this article.

Speaking of an alarm clock invented by Caravagius in the sixteenth century, Alciat wrote: "Every time the hour was heard, a spark, struck out of a flint by a pistol, set to fire some sulphur which lighted up a candle."

Fig. 1 reproduces a Renaissance clock in the shape of a monstrance. Underneath the dial, which is supported by a caryatid, projects the spout of a Jewish lamp in which was placed a wick dipping in oil contained in the body of the caryatid and in the stand on which it rests. This piece is in gilt bronze, well chased.

A curious clock (Fig. 2), made at Saltzbourg, in the beginning of the seventeenth century, belongs to one Planchon. Its

of a gearing with the works moving the hour hand on the inferior dial, which causes the second glass disk to revolve, so that the top dial shows the exact time indicated on the lower one. A night lamp is placed behind the glass dial. The two glass discs being transparent and looking as if they were but one, cause the clock to seem quite mysterious.

There is also in Planchon's collection a night lamp (Fig. 3), constructed on the clepsydra principle. This style of lamp was often used in the seventeenth century in private libraries. It consists of a Jewish lamp fixed at the base of a glass recipient screwed vertically on to a tin stand. Two tin bands, one on each side, run along the recipient from the base up. Hour marks in relief show on the band placed on the same side as the lamp. These hour marks indicating the night time run from 4 (the earliest dark hour in Winter) to 7 in the morning. The glass recipient was filled with oil so that the level of the oil should correspond exactly with the hour at which the lamp was to be lighted. The level, gradually lowering as the oil was being consumed, indicated the time.

A Dutch night lamp of the eighteenth century (Fig. 4) shows a peculiar contrivance. The hour marks are in pierced work.

\*Adapted from *La Nature*, Paris, France.

# Diamonds

.. AND ..

# Diamond Jewelry

.. FOR THE ..

## HOLIDAYS.

We have an unusually large stock of mounted goods all set in the latest designs of mountings and at prices that cannot be beaten.

We have imported a large reserve stock of Diamonds, and will not advance any of our prices at present. Dealers making their selections now will have the full advantage of the low tariff prevailing on Diamonds before the Wilson Bill went into effect.

You can save 15 per cent. by buying your Holiday Stock now.

If inconvenient to call upon us, or if you have a call for some special article not in your stock, let us send you a selection package.

## Cross & Beguelin

Loose—DIAMONDS—Mounted.

17 Maiden Lane,  
New York.

43 RUE MESLAY, PARIS.

## The History of Spectacles, Telescope, Etc.

SEVERAL of the leading publications of the European press have been agitating the subject of celebrating a double centennial in honor of two of the greatest inventions—beside printing—made during the past ages. About six hundred years have elapsed since the invention of spectacles, and three hundred years since that of the telescope. What is the name of the invention of by-gone ages—printing excepted—that has a greater claim to an honored remembrance of grateful mankind? Is there a family anywhere among the civilized nations where the one or the other is not in daily use or as well known as “household words?” One restoring the vigors of youth to the waning sight of enfeebled old age; the other permitting us to examine the starry sky and to read the secret laws by which the universe is governed. It permits us to study the star, the light of which required six thousand years to reach this orb, or to admire the consistency of creation by scanning the harmony of atoms of a size of the two hundred thousandth part of one inch.

It is a deplorable fact, however, that these inventions belong to the very large class of which both the name of the inventor and the time when made are unknown; painstaking research, even, has failed to establish these points, and it would therefore be rather impracticable to celebrate an event of which we know nothing; it is well, however, to recall occasionally the dates of the inventions and gratefully remember the unknown inventors.

While at the present day our inventors hasten to take a patent for the result of their cogitations, it was otherwise formerly. Those of former ages preferred to withdraw theirs from the attention of others. Every guild had its special guild secrets, and every shop its shop secrets, guarded with jealous care. When Guttenberg separated from his partners, Faust and Schoeffer, his greatest sorrow was that the art of printing could henceforth be guarded as a secret no longer. We next must remember that the mechanical auxiliaries of work—to which we may also class spectacles, microscopes, etc., are never introduced in a finished state; between the first inceptive thought and the finished tool that meets with universal recognition of its merits and subsequent adoption by those requiring its services, lies generally a wide range and space of time. The developing progress of human creation is a very slow one, and in most instances the inceptive thought cannot be traced to its sources. When names and dates begin to be mentioned we no longer have before us the initial stages of a useful invention, but those toward perfection. The germ of a great invention is almost invariably hidden—for instance, that of the watch. All our mental and mechanical auxiliaries are the product of inventive genius of succeeding generations and the

nature of individuals disappear, save a fraction. The history of the mechanical auxiliary in universal use to-day is the history of the progress of mankind.

If we were called on to mention instances of the intimate relation between the working tool and civilized life, it is only necessary to quote the history of development of the clock or of the microscope and telescope, and to compare the results of progressive adaptation. Every step of advancement in trade, art or science, calls for the improvement of the auxiliaries, employed by its votaries—one is the supplement of the other.

The art of cutting and enhancing the appearance of jewels and glass was well-known to the ancients, and a number of specimens of the lapidaries' art can be found preserved in our art museums. Among them are lenses, both concave and convex, the ages of which are stated to be more than 3,000 years; some are of a transparent, others of a translucent material; Layard found in the ruins of Niniveh a lens, about 1½ inches in diameter, with a four-inch focus.

It cannot be doubted but that the people who understood the cutting of these lenses, were acquainted with their magnifying power, and also used it; their admirably fine works of the lapidaries of ancient times tend to show that they were executed by means of magnifying agents, although there is only one instance mentioned in ancient writings. Pliny states that the European Nero watched the gladiators, while looking through an emerald. Both Pliny and Suetonius say that Nero was short-sighted, and we may, therefore, conclude that the emerald he used was thin enough in the center to be transparent.

Ancient writings do not contain a more concise description of the effects of spherically cut lenses; the first distinct mention is made by the scientific Arabian physician, Alhazen, who was also the first to give a closer anatomical description of the eye (about 1100 Christian era.) He understood the optical effect of a spherical segment of some compact transparent material. He says: “Such a spherical segment, when placed between the eye and an object, so that the spherical surface is turned toward the eye and the object held close to the plane, the object will be enlarged apparently.” But it may be doubted whether Alhazen really possessed such a plano-convex lens; it is far more probable that he made his experiments with glass vessels of about the shape described, and filled with water. This would explain his assertion that the magnifying effects of the article could be but seldom employed.

Later writers on optics repeat the assertions of the Arabian scientist, but do not venture very far into details, or explain the manner of using. The pundit Franciscan friar, Roger Bacon (1216-1294), however, doubtless had a more profound knowledge of optics than his contemporaries. He is occasionally designated as the inventor of spectacles and telescopes.

(To be continued.)

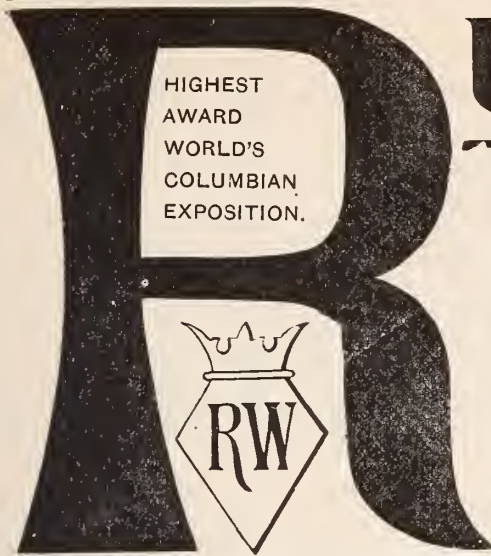

# RUDOLSTADT

## ART POTTERY.

CONTAINS all the elements required as to designs, decorations and workmanship, in a high grade of Art Goods adapted to the Jewelry Trade, and yields a larger margin of profit than any other class of Pottery.

### L. Straus & Sons,

SOLE AGENTS,  
42-44-46-48 Warren Street,  
116 Chambers Street,  
NEW YORK.



**SAFES FOR JEWELERS.**  
MOSLER, BAHMANN & CO., 518 BROADWAY  
NEW YORK.  
Patent Fire and Burglar Proof Safes.

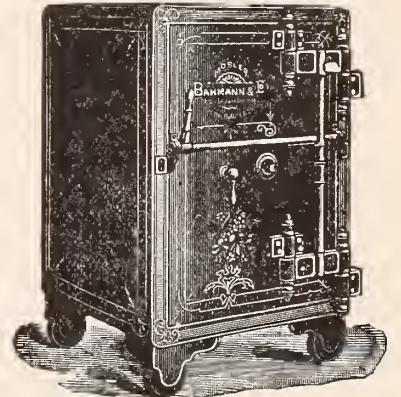

Large Assortment Always on Hand.  
Send for our Representative.  
Special Safes to Order.  
Jewelers' Safes a Specialty.

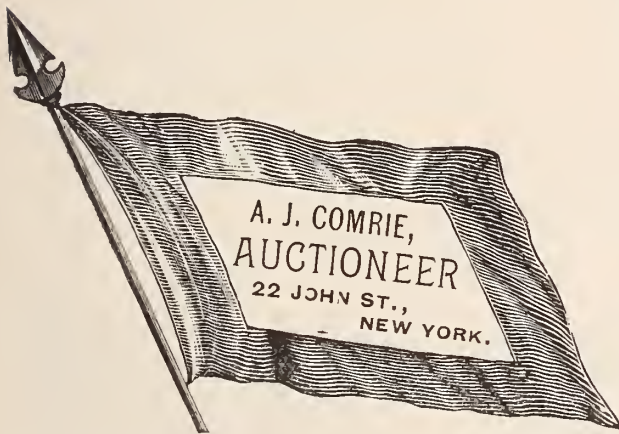

SPECIAL SALESMAN OF  
**WATCHES, DIAMONDS,**  
Bric-a-Brac  
and Art Goods  
FOR  
Established Jewelers.

WRITE FOR PARTICULARS.

Communications Strictly Confidential.

References given in all parts of the United States from Retailers and Jobbers.

### GROUCH & FITZGERALD.

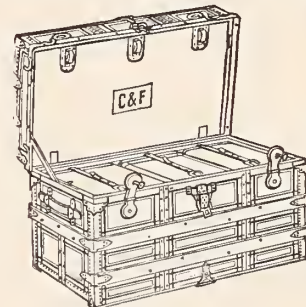

Jewelry Trunks  
and Cases,  
161  
Broadway,  
Bet. Cortlandt and  
Liberty Sts.,  
688 B'way,  
701 6th Ave.,  
NEW YORK

### CODDING BROS. & HEILBORN,

North Attleboro, Mass.

Makers  
OF

# QUICK SELLING NOVELTIES

## In Sterling Silver.

NEW YORK OFFICE—C. A. Vanderbilt, 178 Broadway.  
CHICAGO OFFICE—F. A. Buck, 103 State Street.

### H. M. RICH & CO., Jewelry Auctioneers,

21 School Street.  
BOSTON, MASS.





# FERDINAND BING & Co.,

106 GRAND ST., N. Y.

NEW DESIGNS IN \_\_\_\_\_

China Clocks and Gilt Bronze Sets, Fine Painted

Dresden Goods in Vases, Cups and Saucers, and Plates;

Cararra Marble Statuary, French Cabinets and other

Fancy Furniture.



## TOWLE MFG. CO.,

# Silversmiths,

NEWBURYPORT, MASS.

149-157 State St., Chicago, Ill.

## FLAT WARE AND HOLLOW WARE

STAMPED



IS THE GENUINE.

Manufactured by

WM. ROGERS M'F'G CO.,  
HARTFORD CONN.

# BOYLE, DAVIS & GOODMAN,

SPECIAL AUCTIONEERS for the Legitimate Trade only.

68 Fifth Avenue  
NEW YORK.

611 Pennsylvania Ave.,  
WASHINGTON, D. C.



S. A. BOYLE.



W. M. DAVIS.



CHAS. P. GOODMAN.

WE PAY ALL OUR OWN EXPENSES. GUARANTEE TO MAKE YOUR SALE WITHOUT LOSS.

SEND FOR OUR BUSINESS PAMPHLET.

CONSULT US BEFORE PLACING YOUR SALE. ADDRESS ALL CORRESPONDENCE TO OUR WASHINGTON OFFICE.





## The Rambler's Notes.

WHAT THE RAMBLER SAW AND HEARD AMONG THE DEALERS IN ART POTTERY, CUT GLASS, BRONZES, ETC.

A DISPLAY OF REDON WARE.

**M.** REDON, the well known manufacturer of fine porcelain, of Limoges, France, has opened a New York branch at 43 Murray St. His representative in this country is Henry Seedorf who is no stranger to the jewelry trade, having been for 30 years with Chas. Ahrenfeldt & Son. Mr. Seedorf will, at the New York warerooms, constantly keep on hand full lines of the latest and richest pieces in the artistic designs and decorations for which Redon china is famous. Those for the import season of this year are already on display.

GILT MOUNTED BONN.

**B.** AWO & DOTTER, 30 Barclay St., New York, are displaying the first shipment of a rich line of gilt mounted Bonn ware, which they expect will be thoroughly appreciated by the jewelry trade. The assortment now shown includes vases, ewers, and table centers in the form of fruit and flower bowls with side pieces. The feet or stands, handles, and in some the neck, are of gilt, while the decorations show the usual rich floral designs of the Royal Bonn. Some of the pieces show two body colors, cream and pink, and cream and blue.

IMPORT SAMPLES OF LIMOGES CHINA.

**A**MONG the first of the import samples of French china novelties to be seen in the market are those in the white and decorated china of J. Pouyat, Limoges, France. These pieces are to be found at the office of their New York agent, Alfred Lindsay, 56 Murray St.

INCREASED STOCK OF BRIC-A-BRAC.

**B**Y Jan. 15th, Hinrichs & Co., 31 Park Place, New York, expect to show a complete assortment of their import samples of fine china, art

pottery, glassware and bric-à-brac. Two of the upper floors of their buildings are now being rearranged to better accommodate this display which, it is confidently stated, will include the finest, richest and most extensive lines ever shown by this firm. This is in addition to the regular staple lines to be displayed in their warerooms.

NEW GOODS FOR 1895.

**M.** MONTAGUE F. HARRIS, resident of the Chas. Jacques Clock Co., is now in Europe purchasing goods for his house. Mr. Harris sailed Dec. 22d on the *Umbrina*, and will make an extended tour through England and France, selecting stock for this year. The import samples will be ready and on display at the company's warerooms, 22 Cortlandt St., New York, about the first or second week in February.

NEW IMPORT SAMPLES.

**L.** AZARUS, ROSENFELD & LEHMANN, 60 Murray St., New York, are now at work getting out their import samples which will be on display in about two weeks. The assortment of their own Victoria ware, already opened, shows more new shapes and decorations than ever before.

THE RAMBLER.

## Activity in the Potteries.

**I**T is many years since there was so much activity displayed in the Staffordshire Potteries as that can be witnessed just now, says the *Pottery Gazette*, (London) for December. It is surprising how some manufacturers, from an apparent state of lethargy caused by a stagnant trade, can, on the instant, so to speak, arouse themselves and prove capable of meeting unusual demands upon their resources. Yet this is what has been done by many of our potters. In the closing months of the year when the Winter promised to be a most gloomy one, a large demand was made

upon them, and we now find them busily employed, sending away shipments at a rate that is really surprising.

To illustrate our meaning, take for instance the week ending Nov. 10. To America the shipments were 2,012, as against 1,613 for the same period of 1893. Of course we are aware that it may be said that the packages have been waiting shipment for months past. This, however, on inquiry is not, we find, strictly correct, but that the present speedy productive power should be remembered. In the quiet days through which the trade has passed manufacturers have been steadily enlarging their works, building new factories, and putting down the most modern appliances of all kinds.

"If this had not been done," remarked a potter to us the other day, "it would have been impossible not only to cope with the present demands, but those which we expect to arise in the near future." The general feeling throughout the pottery districts is that continued efforts at production must be put forth, or else with the approaching expansion of foreign and colonial markets the orders will be kept on the books too long, and may drift into other channels. In other words, the manufacturers must be in a position to face the keen competition which is sure sooner or later to arise and soon hold their supremacy.

From the shipments quoted, it will be evident that the American trade is brisk, and orders are coming in from the Western continent steadily. Australian trade is also steadier, whilst the home manufacturers are busy with their Christmas lines. Indeed the pretty novelties being produced for the festive season appear to be more numerous than usual, and the prospects of the fancy trade are described as bright. The outlook for the Fall is encouraging, and efforts will undoubtedly be made to take the fullest advantage of whatever the day may offer. It will, however, probably be early in the year before the whole of the manufacturers and operatives feel the benefits of a steady revival in the trade. At least this is the expressed opinion of those who profess to know the bearings of the industry.

# AMERICAN WATCH TOOL CO.

ESTABLISHED 1872.  
INCORPORATED 1894.

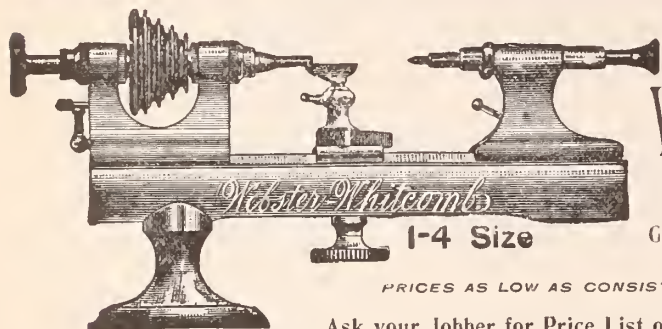

THE  
**Webster=**  
**Whitcomb**

I-4 Size

GROWS IN POPULARITY.

PRICES AS LOW AS CONSISTENT WITH QUALITY.

Ask your Jobber for Price List of 1895, or write to us at

**Stoney - Batter Works, Chymistry Dist., Waltham, Mass.**

## VACHERON & CONSTANTIN, GENEVA, SWITZERLAND.



FINEST QUALITY OF WATCH MOVE-  
MENTS, FITTING ALL SIZES OF  
AMERICAN CASES.



**EDMOND E. ROBERT,**

Agent for the United States and Canada

21 & 23 MAIDEN LANE.

NEW YORK.

## THEODORE C. STEINHAUS,

— MANUFACTURER OF —

### Fine Cases and Trays

For JEWELRY, SILVERWARE, &c.

SAMPLE CASES AND TRAYS FOR TRAVELERS.

Fancy Hard Wood Chests for Silverware, &c.

Linings, Cushions, Mounting, etc., for Sil-  
ver Novelties.

10 MAIDEN LANE, NEW YORK.

## Jules Jürgensen OF COPENHAGEN

The reputation these watches have maintained for  
**Fifty Years** has never been equalled, being made  
on strictly scientific principles and no expense spared to  
give the **Best** results in mechanism and timekeeping  
qualities.

SOLE AGENTS.

**John C. Hyde's Sons,**  
NO 22 MAIDEN LANE.



**AGENTS LADIES OR GENTS**  
**\$75 A WEEK.**  
At home, using or selling **Gray**  
**Plater**, or collecting goods for us  
to plate. We do all kinds of plat-  
ing at our works, manufacture the  
materials and outfits, and **teach**  
**the art.** We sell the only complete  
outfit, including lathe, wheels, tools  
and materials for polishing, prepar-  
ing, plating and finishing every-  
thing. Circulars and prices free.  
**Gray & Co., Plating Works,**  
Don't I. Columbus Ave.

## MARINE CHRONOMETERS,

MANUFACTURED BY

**John Bliss & Co., 129 Front St., New York.**

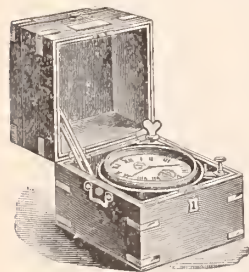

We have on hand a number of Chronometers, by various good makers, not new,  
which have been in service for purposes of navigation, and are excellent instruments.  
They have been put in perfect repair and will give satisfactory results as to perfor-  
mance. We will sell these Chronometers at low prices, either for cash, or on accom-  
modating terms to suit special cases, or will hire them at moderate rates and allow the  
hire to apply on purchase.

SEND FOR CIRCULAR GIVING PRICES AND TERMS.

## The Other Side of Life.

VERY STRIKING—An Alarm Clock.—*Puck.*

MAUDE (at the piano)—I do hate these  
finger exercises. I think they're just horrid.

EDITH—Why, I think they're lovely.  
They do show off one's rings to such ad-  
vantage, you know.—*Boston Transcript.*

A RICH ADORNMENT.

"What a singular brooch Mrs. Newrich  
has on! Is it enamel?"

"No. It's a thousand-dollar bill glazed."  
—*Harper's Bazar.*

TIME IS MONEY.

It was nearly five o'clock, and the man  
was on his way home from work when he  
met a wanderer who had no home.

"Excuse me," said the wanderer; "do  
you think time is money?"

"That's what they say," responded the  
man.

"And what time is it now?"

"About five o'clock."

"Well, give me about five cents and be  
thankful I didn't strike you at 10 o'clock."

He got the nickel.—*Detroit Free Press.*

RECOGNIZED A FELLOW CRAFTSMAN.

A commercial traveler of the more flashy  
type, according to the *Washington Post*, had  
just finished a startling story, when the  
listener, a new acquaintance, remarked:

"That reminds me of one of Munchausen's  
fairy tales."

"Munchausen," answered the drummer;  
"who is he?"

"Why, don't you know about him? He is  
the most colossal example of mendacity that  
civilization has produced."

A moment of silence followed, broken by  
the commercial traveler.

"Excuse me," he said, "would you mind  
telling me what house he travels for?"

**For Sake of Appearance.**—It adds to  
the appearance of fine watches to polish  
the flats of cap settings in dome and set-  
tings in plate by "stripping" them upon  
diamond faced agates or jasper. This is  
done dry, the setting being rubbed with  
clean felt buff over the surface of the stone.  
The sink polishing is done with "stripping"  
graver, reversing the lathe from you very  
slowly, and turning out final cut with the  
highly polished graver.

# KELLER, ETTINGER & FINK,

SELECTION ORDERS SOLICITED.

24 JOHN STREET, NEW YORK.

DEALERS IN

MOUNTERS OF

IMPORTERS OF

American Watches.

Fine Diamond Jewelry.

Diamonds.

**THE ARTHUR CO.,** LEADING DESIGNERS  
**DIAMOND MACHINERY** AND BUILDERS OF  
 IN THE UNITED STATES.  
 Machine Works, 86 John Street and 188-190 Front Street, NEW YORK

**HAGAN, WHITE & CO.,**  
 MANUFACTURERS OF  
**GOLD AND SILVER MOUNTED CANES, UMBRELLAS & NOVELTIES.**  
 RICH AMERICAN CUT GLASS, SILVER MOUNTED.  
 248 WEST 23D STREET, NEW YORK.

**WOOD & HUGHES,**  
**STERLING SILVERWARE MANUFACTURERS**  
 New York Agents for the Derby Silver Co.  
**FINE QUADRUPLE PLATED WARE,**  
 No. 16 JOHN STREET, NEW YORK.  
 206 Kearney St., San Francisco, Cal.  
**HASKELL & MUEGGE, Agents.**

Philadelphia College of Horology  
 It is not the largest but is the finest school in the country. A practical school to learn watch-making, engraving, and jewelry repairing. One tuition pays for all branches. Send for prospectus.  
**F. W. SCHULER, PRINCIPAL,**  
 1213 Filbert St., Philadelphia, Pa.  
 Write for particulars of our corresponding course.

**FERD. FUCHS & BROS.**  
**SILVERSMITHS,**  
 MAKERS OF STERLING SILVERWARE,  
 808-810 Greenwich St., New York.

When you buy  
 Cut Glass  
 You want the best!  
 That which bears our  
 Trade Mark  
 Has no superior  
 And will prove profitable and satisfactory.



**T. B. CLARK & CO., INC.,**  
 860 Broadway, N. Y.,  
 Factories: HONESDALE, PA. N. F. Cor. 17th St. & Broadway.

**PRESCRIPTION WORK.**  
**QUEEN & CO.,**  
 1010 Chestnut Street, PHILADELPHIA.  
 SEND FOR PRICE-LIST AND ORDER FORMS.

DON'T FORGET THE JEWELERS' CIRCULAR PUBLISHING CO.'S BOOK LIST when in want of any technical book in the Jewelry or Kindred Trades.

**THE LATEST NOVELTY**  
 IN  
**BIBLE BOOK-MARKS.**  
 MOUNTED WITH  
 Sterling Silver or Gold Ornaments,  
 ON ALL SILK RIBBONS, 8 1-2 INCHES LONG  
 WITH APPROPRIATE QUOTATIONS  
**WOVEN IN THE SILK.**

Nine different quotations. Ribbons in the following colors: Purple, black, white and lilac. Can be sold profitably at a popular price. Made only by

**STONE BROTHERS,**  
 535 Broadway, NEW YORK.

**MATHEY BROS., MATHEZ & CO.**  
 21 & 23 MAIDEN LANE, N. Y.  
 BRASSUS, SWITZERLAND.  
 MANUFACTURERS OF  
 THE SMALLEST,  
 THE THINNEST,  
 THE NEATEST AND  
 THE BEST  
**SPLITS.**

SOLE AGENTS FOR  
**JAQUES • LECOULTRE • RAZORS.**

**AIKIN, LAMBERT & CO.,**  
 CHICAGO BRANCH: 103 State Street. No. 19 MAIDEN LANE, NEW YORK.

Manufacturers and Exporters  
 Gold Pens, Holders, Pencils, Toothpicks and Novelties

**MERCANTILE** **FOUNTAIN PEN.**

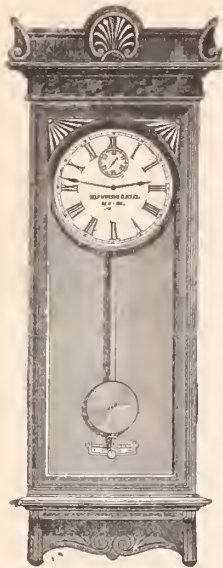

**SELF WINDING CLOCK CO.**

NEW YORK-CHICAGO.

HALL CLOCKS,  
OFFICE CLOCKS,  
Synchronized Time Plants.

No Winding. Corrected Hourly

BY TELEGRAPH SIGNALS OVER WESTERN UNION TEL. CO.

Wires from U. S. Naval Observatory, Washington, D. C.

General Office:  
26 BROADWAY, N. Y.

Branch Office:  
Columbus Memorial Bldg, Chicago.

Sold by all whole-  
sale dealers at manu-  
facturer's price.

**A. N. CLARK & SON**  
PLAINVILLE  
CONN.

Manufacturer of the Celebrated  
**LOOP WATCH KEY.**

The Best for the Price in the World  
CROSBY'S JEWELING TOOLS IMPROVED.

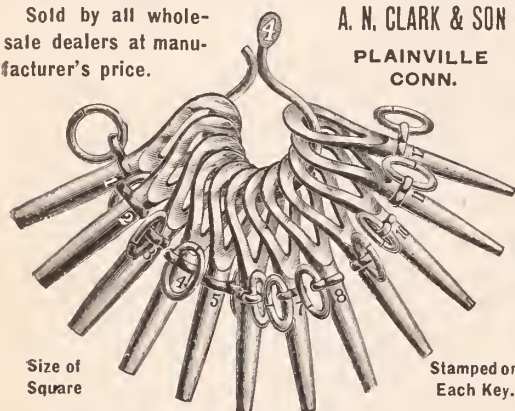

Size of  
Square

Stamped on  
Each Key.



Will quote royalty or price for the manufacturing of articles of real worth.

**DIAMONDS.**

**C. COTTIER & SON,** IMPORTERS OF PRECIOUS STONES,  
14 MAIDEN LANE, NEW YORK.

C. A. RICHARDS, Agt. 151 Weybosset St., Prov., R. I.

**FANCY GEMS.**

**\$3.00**

FORMERLY

**\$6.00**

Ivory and  
Enamel  
Miniatures



Best  
Workmanship.

Original  
Inventor and  
Patentee of  
**Miniatures**  
—ON—  
**Gold and  
Silver.**

PATENTED  
November 12, 1889

**LEON FAVRE.**

107 EAST 26TH STREET,  
NEW YORK.

**U. S. SMELTING & REFINING WORKS.**

Sweep Smelting and Assaying. Platinum in Plate and  
Wire. Chemically Pure Copper. Ore and Bullion  
Assays a specialty.

Highest prices paid for old gold and silver.  
Sole manufacturers of Phoenix Flux  
and Eureka Alloy.

M. WOLLSTEIN. 25 John St., New York.



**B. & W. B. SMITH,**  
220 W. 29th St., New York.

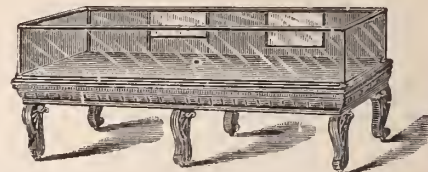

Improved Dust-Tight Counter Cases,  
Perpendicular Sliding Doors.

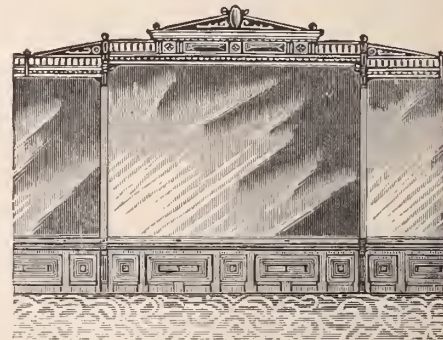

Improved Dust-Tight Wall Cases.  
Furnished with Improved Shelving and ar-  
ranged for Electric Lighting.

**S. F. MYERS & CO.,**

Manufacturing and  
WHOLESALE JEWELERS,  
1895 Issue, No. 39.

**OUR ROYAL CATALOGUE**

Illustrates all that is new, unique  
and desirable in

everything that pertains to jewelry.  
600 pages, size of this publication.  
Free to dealers.

SEVEN DOUBLE FLOORS.  
TWENTY-TWO DEPARTMENTS.

48-50 Maiden Lane,  
Myers Buildings, 33-35 Liberty St., New York.



.. OUR ..  
**SPECIALTY**

The Largest Stock of  
**CHIMING**

—AND—  
**STRIKING**

**HALL CLOCKS**

ever shown.

**Chas. Jacques**

CLOCK CO.,  
22 Cortlandt Street,  
NEW YORK.

**IT PAYS** TO KEEP IN TOUCH WITH TRADE AFFAIRS. **THE JEWELERS' CIRCULAR.** For 4c. a Week will do it. **Subscribe.**

**DIAMONDS** and Cutters. **L. & M. KAHN & CO.,** 177 Broadway, New York.

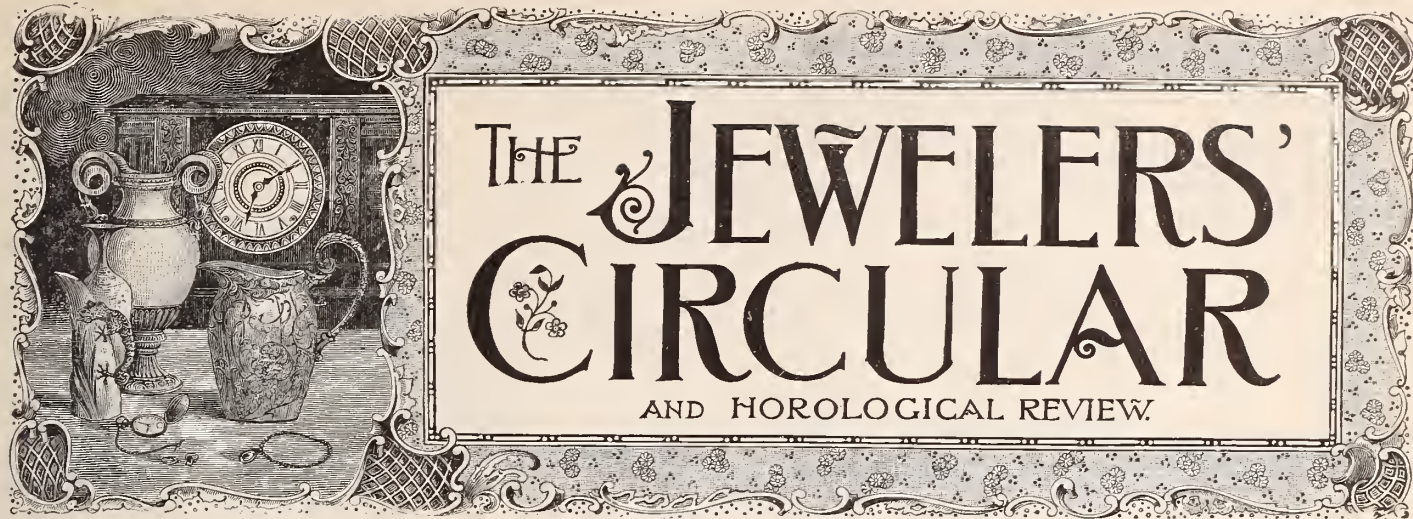

Copyright by THE JEWELERS' CIRCULAR PUB. CO.

189 Broadway, New York.

Entered at the Post Office in N. Y. as second-class matter.

VOL. XXIX.

NEW YORK, WEDNESDAY, JAN. 9, 1895.

NO. 24.

SECOND COSTLIEST JEWELLED MONSTRANCE IN THE WORLD.

THE most magnificent monstrance or ostensorium ever made in this country, and the second costliest in the world, was recently delivered to the Associate Fathers of the Church of St. Ignatius of Loyola, Baltimore, Md. It is the gift of the late Mrs. Celinda Whiteford, of that city, who, prior to her death, contracted for its manufacture and donated it to the church as a memorial to her son, the late Robert Louis Whiteford. Its value is estimated at \$12,000, which is a low figure, as the jewels which decorate it were part of the private collection of Mrs. Whiteford, who had the gift in contemplation for a long time before awarding the contract. She accepted the design of the W. J. Feeley Company, of Providence, R. I., and last August she instructed this company to have the monstrance completed by Christmas. Her instructions were carried out by W. J. Feeley. Mrs. Whiteford died some months ago.

Of the many sacred vessels used in the ceremonies in Roman Catholic churches the monstrance or ostensorium is oftener seen, perhaps, by the members of the congregation, than any other, for the reason that it is used at the Benediction of the Blessed Sacrament. It is made to represent the rays of the sun, for it holds the "Sun of Justice." Christ, ages ago, was said to have "placed his tabernacle in the sun," and the monstrance is for the adoration of his people at benediction and at the processions of the Blessed Sacrament. The host is first placed in the lunette, formed of two rings with glass, and then in the monstrance

The Whiteford monstrance is made of solid gold, and stands 32 inches high, and

the diameter of the base which is mounted upon the heads of four lions, is 12 inches.

The decoration of the base has given the embosser, engraver and enameler an opportunity to show their skill. There are four panels quarterfoil, richly carved, on which are set medallions emblematic of the four evangelists, in blue enamel—the symbol color of Heavenly Love, Truth, Constancy and Fidelity.

Saint Matthew is represented by a cherub, typical of the human nature of Christ, because he speaks more of the human than of the divine nature of the Saviour. A lion symbolizes Saint Mark. The king of beasts is a type of the royal dignity of Christ. According to an Oriental tradition, lions are born dead, and after three days are made alive by the breath or roar of the Sire; thus they are emblematic of the Resurrection, of which Saint Mark is called the historian. The Ox is the symbol of Saint Luke, and he especially sets forth the priesthood of Christ. The ox is typical of sacrifice. The Eagle, symbol of Saint John, is typical of the lofty flights of inspiration.

These emblems have been used in memory of the Incarnation, Passion, Resurrection and Ascension of Christ. Between these panels are vine leaf and grapes, emblematic of the Saviour, "The true vine and wine of our divine Lord." Above these and at points of the base below the column, the significant initials, "A. M. D. G." "Ad Marjorem Dei Gloria," "To the Greater Glory of God" appear in enamel. Directly under the initial "A," is a beautiful diamond incrustured "W," in an onyx stone

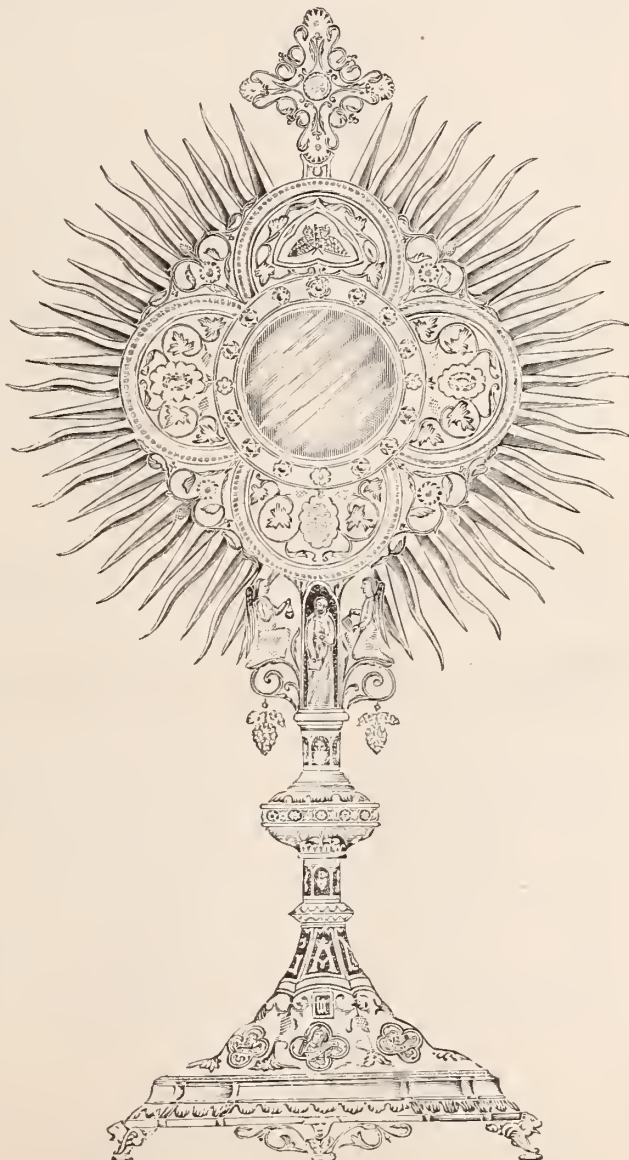

JEWELLED OSTENSORIUM FOR THE CHURCH OF ST. IGNATIUS,  
OF LOYOLA, BALTIMORE.

THE AMERICAN KNIFE AND  
SCISSORS SHARPENER.



TWO-THIRDS SIZE.

PAT. FEB. 23 '92.

For Table Use.

Special Inducements to Jobbers

... Manufactured only by the

**MOSSBERG WRENCH CO.,**  
ATTLEBORO, MASS.

Makers of **Novelties in Silver and Hardware.**

- FOR SALE BY**
- Benj. Allen & Co., Chicago, Ill.
  - F. M. Sproehle & Co., "
  - G. A. Webster, "
  - L. Straus & Sons, New York.
  - E. G. Webster & Son, "
  - Oskamp, Nolting & Co., Cincinnati, O.
  - Baldwin, Miller & Co., Indianapolis, Ind.
  - Eliassof Bros. & Co., Albany, N. Y.
  - Thos. Long & Co., Boston, Mass.
  - Smith & Patterson, "
  - Dame, Stoddard & Kendall, Boston, Mass.

**Practical and Handsome.**

A Silver Plated Knife and Scissors Sharpener, retailing at a popular price. Perfect in action, nothing to wear out. Cutting discs of finest hardened steel. An ordinary sharpness or a RAZOR EDGE can be acquired in a few moments.

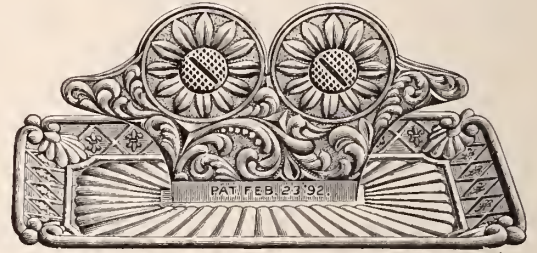

TWO-THIRDS SIZE.  
FOR DESK USE.

**CODDING BROS. & HEILBORN,**  
North Attleboro, Mass.

Makers  
OF

**QUICK SELLING NOVELTIES**  
In Sterling Silver.

NEW YORK OFFICE—C. A. Vanderbilt, 178 Broadway.  
CHICAGO OFFICE—F. A. Buck, 103 State Street.



For **BADGES and MEDALS,**  
Flag Pins, Class Pins, Class Rings  
and Special Work of all Descriptions,  
SEND TO **E. R. STOCKWELL, MANUF'R,**  
19 John Street, New York.

**R., L. & M. Friedlander,**



We have made great reductions in the prices of Watch Glasses.

SEND FOR PARTICULARS.

Are now located on  
ground floor of

**30 Maiden Lane, N. Y.**

IMPORTERS OF  
**DIAMONDS.**

WHOLESALE  
**JEWELERS.**

JOBBERS IN  
American Watches.

SEND FOR OUR NEW CATALOGUE.

IMPORTERS OF  
**DIAMONDS.**

JOBBERS IN  
Watches, Jewelry, Chains,  
NOVELTIES, ETC.

Latest Designs. Lowest Prices.

**AIKIN-LAMBERT  
JEWELRY CO.,**

19 Maiden Lane, New York.

CHICAGO BRANCH '03 STATE ST.



# FOSTER & BAILEY,



100 RICHMOND ST., PROVIDENCE, R. I.

Manufacturing Jewelers and Silversmiths.

925/1000.

HEADQUARTERS FOR MANICURE GOODS.



Garters

Link Buttons

Scissors

Neck Chains

Bag Tags

Glove Buttoners

Hat Marks

Chain Mountings

Pen Wipers

Shirt Waist Sets

Emery Balls

Crosses, Earrings

Match Boxes

Solid Gold Locket

Coat Hangers

Locket and Charms

Pocket Knives

Silver Belt Buckles

Pocket Combs

"Mount Hope" Buttons

Paper Cutters

Bracelets and Padlocks

Seals, Button Hooks

Pins and Neck Buckles

And Silver Novelties

Rolled Plate Watch Chains

Without End, all Sterling.  $\frac{1}{10}$  Gold Vest and Dickens Chain.

And also those

**HANDY SETS FOR TOILET IN LEATHER ROLLS.**

from a ring worn by Mr. Whiteford, richly mounted on either side with a scroll, artistically arranged, on which is engraved the memorial inscription, "Robert Louis Whiteford, by his mother." At this point, the shaft or column begins, and its every inch up to a group of figures at the top, is given the most artistic treatment.

Directly above the letters "A. M. D. G.," are emblems of the "Sacred Heart of Jesus," the "Immaculate Heart of Mary," "The Passion Flower" and "The Calla Lily," the emblem of purity. Above these is a knob, around the center of which is a row of diamonds, the middle one being very brilliant and weighing two karats and the others one karat each. At the top of the column is a bracket, on which is standing a richly modeled figure of St. Ignatius of Loyola. On either side mounted on artistically arranged scrolls, are the figures of two angels, one with the lyre and the other with the thurible, while suspended from the scrolls are two clusters of diamonds, each containing 25 quarter-karat stones.

The front ornamental plates are models of repoussé work. On them is a handsome display of diamonds. Directly above the center on the front plate is a pin containing 50  $\frac{1}{4}$  karat diamonds and 2 small rubies representing a fly. Immediately below the center is a pendant, in its original setting, which also contains 50  $\frac{1}{4}$  karat diamonds and on either side of the center are two large amethysts. Separating the front plates and mounted on entwined hearts are four solitaire diamonds, two weighing four karats each, and two three karats each. Between the diamond fly pin and the center, on a circle surrounding the custode, which contains the lunette, is a black diamond, the intrinsic value of which is estimated at \$1,000. On the right of this are two diamonds and an emerald, each weighing about  $3\frac{1}{2}$  karats, and on the left are two  $3\frac{1}{2}$  karat diamonds and a sapphire.

Around the lower part of the circle are eight 2 karat solitaire diamonds and three pearls weighing about two grains each. The whole is surmounted by a magnificent cross, in the center of which is a cluster of eight  $\frac{3}{4}$  karat diamonds, and below this cluster is a diamond pin, attached to the cross, containing nine  $\frac{1}{2}$  karat diamonds and a cat's-eye stone measuring three-eighths of an inch. On each arm, and at the top of the cross, are large diamonds weighing four karats each. The ray extends in graceful curves, the diamonds scintillating and producing an effect that is dazzling.

The vault in which are the monstrance and other valuables belonging to the church and college is absolutely fire and burglar proof, and so arranged that an unauthorized person approaching within six feet in any direction will cause an alarm to be sounded in all parts of the church and college.

#### Litigation Growing Out of the S. Kirk & Sons Robbery Cases.

BALTIMORE, Md., Jan. 2.—The expected damage suits against Samuel Kirk & Sons by employes recently acquitted of the charge of stealing and receiving stolen silver have been filed in the Supreme Court. There were four of them, and the damages asked aggregate \$85,000.

The suits are brought in behalf of Marcus Korman, who was charged with receiving stolen silver, and Louis Falkenstein, Andrew Addison and Llewellyn Walker, charged with stealing silver. All of them sue for \$20,000 each, except Korman, who asks for \$25,000. The grounds on which such heavy damages are asked are: false and malicious arrest and prosecution, without probable cause; hardships and indignities of arrest and imprisonment; injury to credit and reputation; loss of employment; anxiety of mind; scandal, infamy and disgrace.

#### Notes of Interest From Paris.

PARIS, France, Dec. 12, 1894.—An old goldsmith, who is an *esprit chercheur*, has obtained a patent for a metal composition, which he calls auro-marble silver. This metal which has the appearance of precious marble consists of silver in which parts of fine gold, green and red gold and platina are incorporated, not amalgamated. These pieces of various metals are, probably, thrown in a special manner into a crucible containing silver in a melting state at a certain temperature, then quickly stirred so as to scatter them about the mass, the ingot being suddenly cooled when all looks *à point*. Articles fashioned out of this metal need not be decorated, as the metal itself gives a great variety of pretty effects, according to the way it is finished, viz.: polished, or *grattebossé*, frosted, oxidized, etc. Bonbon boxes, jewel caskets, card receivers, trays, mirror and portrait frames, clocks, etc., in this style would look very original.

The *Bibliothèque des Merveilles* has just published a book called *La Bijouterie*, by Roger-Miles. The author of this illustrated history of jewelry has judiciously introduced in his book numerous quotations from Fontenay's remarkable work on ancient and modern jewels, published in 1887. The chapter on modern jewelry consists of extracts from Mr. Marret's report on the *bijouterie* at the Paris Exposition of 1889. It is much to be regretted that Mr. Roger-Miles should not have heard of Massin's report on jewelry published at the same time. Had he been acquainted with this source of substantial information, the intrinsic value of his work might have been somewhat increased, yet, in spite of such desiderata, this book ought to be welcome, as it will prove interesting to the *gens du monde*, who may possibly read it, and perhaps awaken in them a commendable liking for jewelry in general. JASEUR.

NEWARK, N. J., January 1st, 1895.



Messrs. Edward P. Beach and Philemon O. Dickinson

have this day become members of our firm.

UNGER BROTHERS.



*Pairpoint*

# MANUFACTURING COMPANY.

## Gold and Silver Plate



No. 3749. MATCH HOLDER.

WE ARE MAKERS OF THE  
LARGEST AND LOWEST PRICED

LINE OF

“Crown Pairpoint” China

Rich Cut Glass,

Fine Decorated Art Goods,

..... TO BE FOUND IN THIS COUNTRY.



No. 4908. SMOKING SET.

“WHEN IN DOUBT”

--- BUY ---

PAIRPOINT GOODS.

Factories, New Bedford, Mass.



No. 2832. KNIFE SHARPENER

### HOLIDAY NOVELTIES

..... OF EVERY DESCRIPTION.

**FREE**

OUR LATEST

SILVERWARE CATALOGUE No. 10, or  
CUT GLASS CATALOGUE No. 11

Will be mailed you upon receipt of address.

SALESROOMS:

NEW YORK, 46 Murray Street.

CHICAGO, 224 Wabash Avenue.

SAN FRANCISCO, 220 Sutter Street.

MONTREAL, P. Q., Temple Building.

We sell to the legitimate Jewelry and Stationery trade only.



NEW YORK

CITY U.S.A

CHOICE PAPERS

MAKERS OF

## FINE STATIONERY

For Correspondence, Wedding and Business Use, handsomely boxed, specially suited to the Jewelry Trade.

18 MURRAY STREET, NEW YORK.

ESTABLISHED 1870.



TRADE MARK.

### SAMUEL C. JACKSON,

MANUFACTURER OF

**FINE CASES** FOR

Jewelry, Silverware, &c., also Hardwood Chests, Trays, and Sample Cases.

**180 BROADWAY,**

**NEW YORK.**

### CROUCH & FITZGERALD.

Jewelry Trunks and Cases,  
161

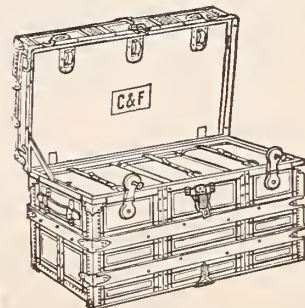

Broadway,  
Bet. Cortlandt and Liberty Sts.,  
688 B'way,  
701 6th Ave.,  
NEW YORK.

# R. WALLACE & SONS MFG. CO.

## SILVERSMITHS,

WALLINGFORD, - - - - CONN.

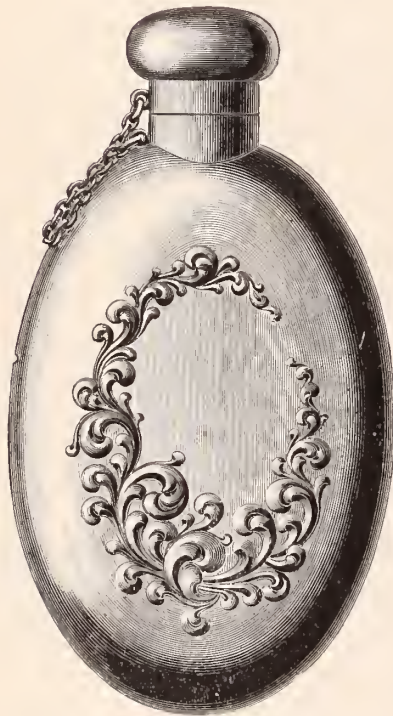

No. 20. FLASK.

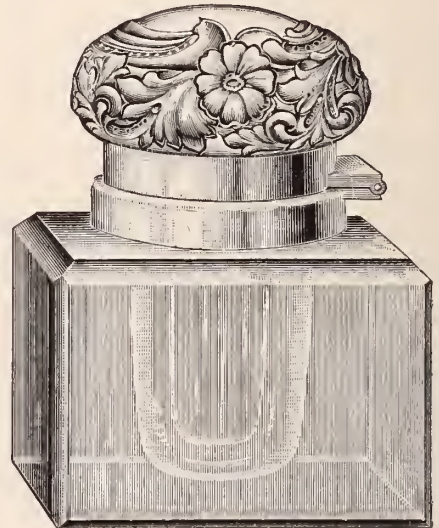

No. 53. INK BOTTLE.  
CHASED TOP.

Trade Mark.



R. W. & S.  
Sterling.

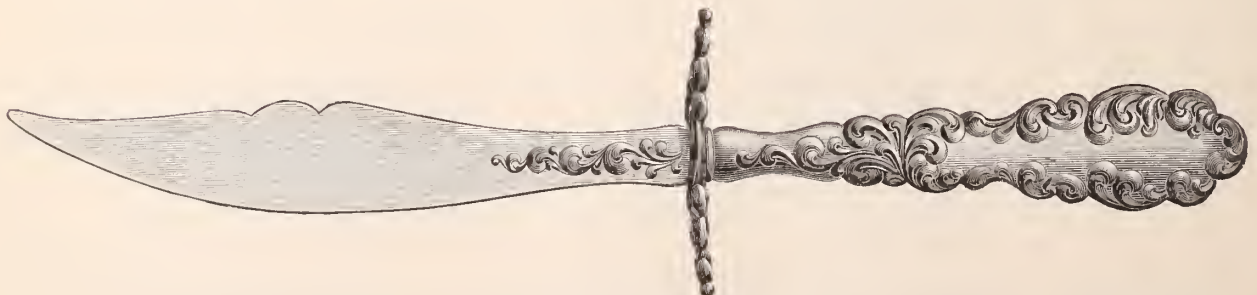

No. 39. PAPER CUTTER.

NEW YORK  
226 FIFTH AVENUE.

SAN FRANCISCO  
120 SUTTER STREET.

CHICAGO  
86 WABASH AVENUE.

## ADVERTISING HINTS FOR RETAIL JEWELERS.

BY CHARLES AUSTIN BATES.

The Editor of THE JEWELERS' CIRCULAR has asked me to contribute a series of articles on retail jewelry advertising.

It is my desire to make these articles as useful as possible and to that end, an invitation is extended to retailers to send to me any of their advertisements which they would like to have criticised. It may be that there are some questions which they will care to ask and that I can answer.

Each week I will give several examples of advertising, which will illustrate my ideas on the subject. I do not present these advertisements with the claim that they are perfect, but only with the hope that they will contain some useful suggestion, and that some dealer at least will find that by making slight changes in them, as local conditions require, they will be able to make use of them, and so relieve themselves of one detail of their business.

### PART XI.

THE best resolution that a retail jeweler can make for the year 1895 is that he will have his advertisement prominently located in the best newspapers in his town. Let him consider that the money he pays for advertising is just that much money well invested. It is something that he cannot lose unless he goes out of business, and even then the advertising has a value. It will make the business bring more money than it would otherwise. There is no doubt that money can be lost in advertising. And so can money be lost in any department of the business.

You can lose money on hollow silverware if you are careless enough about buying and taking care of it. You can lose money on any line of goods that you buy. If you buy advertising with the same care, and look after it as conscientiously as you do the other things that you buy for your business, you will find that it will pay every time. The good will of a well advertised store is sometimes really worth as much as the stock.

Several years ago, Dr. Hoagland, president of the Royal Baking Powder Co., refused something like \$12,000,000 for his business. Now, I don't suppose that all the property that the Royal Baking Powder Co. own, and all their stock on hand, are worth one third of this amount. The balance of the \$12,000,000 represents the value that has been given to the business by years of judicious and persistent advertising. Royal Baking Powder Co. started in the back room of a small drug store in Fort Wayne, Ind. It was advertised locally at first and then generally.

There is, of course, no parallel between the Royal Baking Powder business and the business of a retail jeweler, but the principle is the same. All over this country there are stores running in the name of the man who started them, while neither he nor his heirs have any interest whatever in them. There is no Mr. Macy connected with the great store of R. H. Macy & Co., New York, yet it is known all over the country as "Macy's." The name is valuable as a business property because it is well known as signifying a certain kind of store in a certain place. It would cost hundreds of thousands of dollars to make a new store on the opposite corner as well known as Macy's is to-day. If Charles L. Tiffany had not believed in advertising fifty years

ago, and all the time since, Tiffany's would not now be the leading jewelry store in the United States. The business might have been carried on in just the same manner that it is, on the same principles, and still have amounted to very little if people had not been told about it. It might still be in the little room where it first started at 151 Broadway.

The change has not been made in a day nor in a year. Advertising sometimes works slowly. It almost always does, but it is sure. If the jeweler expects to stay in business, he can count the money he spends for advertising as just so much money saved. If he makes an immediate profit on the investment, so much the better. It does not decrease the cumulative value in the least. In fact, the effort should be always to make the advertisement for each

### Overworked Eyes—

— Like any other part of the human body, require a stimulant when overtaxed.  
— Our stimulant for weak eyes is glasses. If you need them call and see us.  
— Small charge for glasses.  
— Examination free.

**McALLISTER.**

SCIENTIFIC OPTICIAN,  
3 NORTH CHARLES STREET.

day stand for itself. It should be a continual study of the merchant to make each day's advertisement pay for itself and a little more in direct returns. The only way that I know of doing this is to advertise special articles on different days. It is a good plan to buy certain lines of goods that are especially attractive to make a little run on. Any good thing at a low price can be sold by judicious advertising. If you are using weekly papers, have a fresh ad. every week. If you are using dailies, have a fresh ad. every day if you have to lie awake at night a little bit to think it up.

\* \* \*

The above is an example of carelessness in advertising. It comes from Baltimore, Md. It is the kind of thing that makes some advertising unprofitable. Sometimes men will go along for a year or two making

careless statements in their ads and in the end will wonder why the advertising does not pay. The mistake in this ad. is one which a great many people would not notice at all, but the people who do notice it may very likely be just the ones who would become customers, if they were not made suspicious by the careless advertisement. What the eyes, or any other part of the human body needs when it is overtaxed, is rest and help. What it most emphatically does not need is a stimulant. A stimulant

### Faulty Vision

is more or less general in this rushing age. Eyes are often overworked—need help. Glasses may prove of wonderful benefit and relief. I fit them and guarantee every pair I sell. Examination Free.

**Carl H. Peter, M. O.**  
HENDERSON, KY.

is a spur, an irritant. It is not in any way a help. The word "stimulant" is used in a great many cases to signify all alcoholic beverages. Whiskey is a stimulant. If a man is tired out, whiskey will keep him up and make him work a little bit harder and a little bit longer, but it will make the collapse just so much flatter after the effect of the stimulant is gone.

We do not want stimulants for our eyes, Mr. McAllister. The natural inference is, that if a man is careless about the language which goes into his advertisements, he might be a little careless about the lenses that go into his spectacles. This may look like a small point, but it is not.

It is the attention or inattention to just such small points that makes success or failure in advertising and in business.

\* \* \*

In contrast with McAllister's advertisement, I offer one from Henderson, Ky.

### Don't Say A Word

\* \* \* \* If things haven't seemed to come  
\* \* \* \* your way for a year or two, try and  
\* \* \* \* forget the past and begin a new  
\* \* \* \* year hopefully.

### We Are Right

\* \* \* \* At the verge of a period of activity  
\* \* \* \* King Cotton is black in the face  
\* \* \* \* from the hard kicks received, but  
\* \* \* \* we all have three square meals a  
\* \* \* \* day and a country grand in re-  
\* \* \* \* sources. Prices on everything are  
\* \* \* \* low. For proof of

### Good Times Ahead

\* \* \* \* Call on AVERY, The Jeweler,  
\* \* \* \* 131 Main Street, and see the many  
\* \* \* \* beautiful and useful articles suit-  
\* \* \* \* able for presents. Be sure to not  
\* \* \* \* only see them, but get prices on  
\* \* \* \* them.

# A MODEL FACTORY BUILDING.

THE KENT & STANLEY CO.'S MAMMOTH NEW STRUCTURE, THE  
FINEST OF ITS KIND IN THE WORLD.

## THE KENT & STANLEY CO.

Our illustration shows the Sabin St. entrance with the handsome wrought iron elevator in the back ground, and two beautifully silvered supporting columns. The other entrance on Beverly St. is practically the same. Marble slabs for the names of the tenants is another feature not usually found in a factory building, and rapid running passenger elevators at either entrance afford quick access to, or egress from any floor. In the driveway running through from Sabin to Mason Sts., are two commodious freight elevators.

Floorings throughout are of maple, each floor being nearly an acre in area. The supporting columns are of iron, rising thirteen feet to the ceilings. Grinnell sprinklers and all other modern factory conveniences make the building a perfect one, whether from the view of the tenant, the insurance or the factory inspectors. Over 3,500 hands can find accommodation within its walls. Power and light are furnished by the company's private electric plant, one of the finest in the country.

The offices of the Kent & Stanley Co. are fitted up in oak, in the best taste, and pre-

**P**ROMINENT among the many handsome factory buildings for which Providence is noted is the handsome structure built and occupied by the Kent & Stanley Co., on the Square bounded by Sabin, Aborn, Beverly and Mason Sts., in that

city. The property which it occupies was the location of the old-time popular skating rink, destroyed by fire last year. Mr. Edwin F. Kent, recognizing the advantages of the site, on his own responsibility purchased the property after the fire, though at that time the building occupied by the Kent & Stanley Co., at Eddy and Fountain Sts., was generally looked upon as a model factory, excellently planned and perfectly equipped.

Mr. Kent's foresight in the matter of the purchase of the new site was soon endorsed by his partners. Its proximity to the new railroad depot, which will be one of, if indeed not the finest, in the country is a guarantee of increasing values in that section of the city, while the increased shop room was something rendered imperative by the firm's constantly increasing business.

Work on the new structure which is depicted in one of the illustrations in this article, was begun on November 1, 1893, and October 1, 1894, the company was operating in its new quarters.

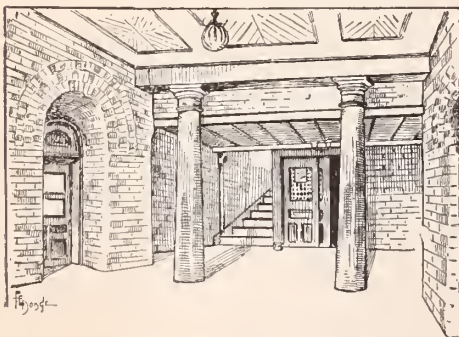

MAIN ENTRANCE ON SABIN ST.

The readers of the CIRCULAR can gather an idea of the immensity of the structure when it is borne in mind that it occupies an

acre of ground, rises seven stories above the foundation, has over 250,000 square feet of floor space, about 1,200 windows and required over five million bricks in its construction. While nearly all available space has already been leased, firms seeking modern quarters will do well to bear in mind that rentals are figured on a basis of 30 cents per square foot per annum, including power, steam heat water and elevator service.

The ground plan and character of the plot is excellently suited for the purpose to which it has been put. The L shaped formation gives it a frontage of 276 feet on Mason St., 221 feet on Aborn St., 106 feet on Sabin St., and 123 feet on Beverly St. A light well 40x200 feet extends from roof to basement in the main structure



THE KENT & STANLEY CO.'S BUILDING.

which with the additional advantage of four street frontages makes that great desideratum, good light, an assured fact for each tenant.

Red brick with brownstone trimmings was the material used for the walls, which rest on particularly solid foundations. At either corner on the Sabin St. facade are two handsome flag staffs held in place by artistic creations in wrought iron of dragons, one of which is incorporated in the initial letter beginning this article. Flags floating from these staffs bear, one, the company's trade mark on a white field and the other the national colors.

The two entrances to the building are well worthy of attention. Each shows a granite arch, while within enameled bricks of a light bluff tint please the eye and present an imperishable surface.

sent an exceedingly attractive and handsome appearance. They occupy practically the whole of the Sabin St. wing on the sixth floor. Our illustration shows a view of the general office; adjoining it is the private office of Mr. E. F. Kent, which also connects with the director's suite.

The Kent & Stanley Co.'s shop, ever known as a model one, is in the new building better than ever. In one of the illustrations accompanying this article is shown a corner in the silver shop, a line in which the company is winning rapid recognition, and of which some of the productions, notably yachting trophies, have already been the subject of extended mention in the CIRCULAR.

A pioneer in selling its goods directly to the retail trade, the company, through its ten traveling salesmen and New York, Boston, Philadelphia and San Francisco offices offers a wide and varied line of goods. Some idea of its scope can be gathered from the fact that among them are

**THE KENT & STANLEY CO.**

One-tenth and one-quarter Gold Seamless Wire Chains; Gents' Rolled Plate Vests, all Seamless Wire, 1, 2, 3, Strand Curbs; Dickens, Trace, Rope, Single Curb, Boston

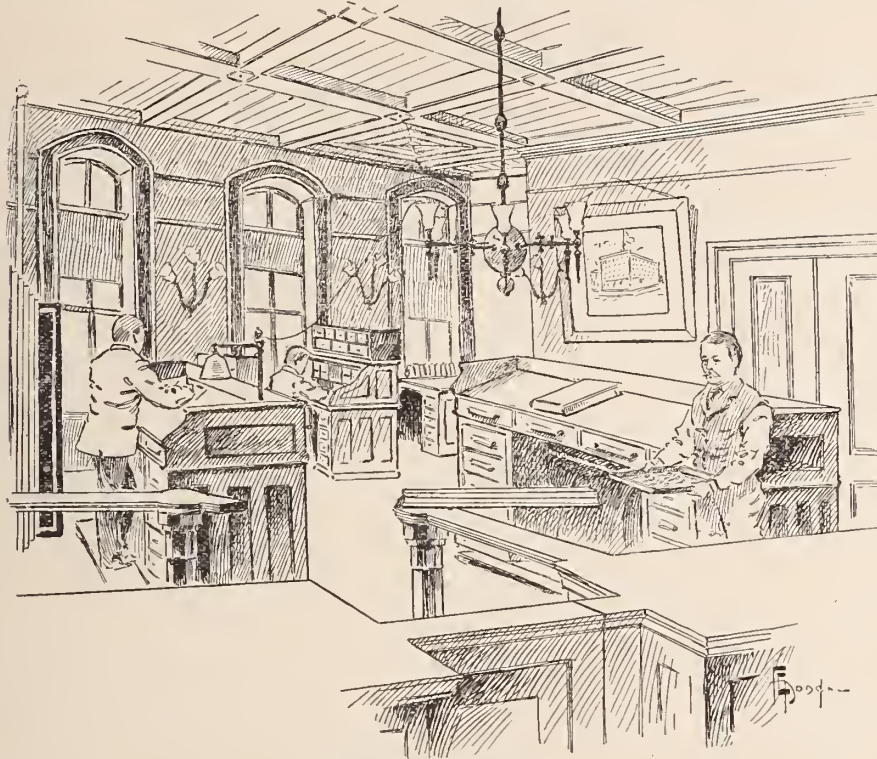

VIEW OF GENERAL OFFICE.

and Fancy Links; Red Gold and Platinum Links in all styles; Ladies' Lorgnette, Neck, Vest and Victoria Chains; 1,500 styles Gold, Silver and Plated Locketts and charms; White Stone Lace Pins and Brooches; Hair Ornaments; Chain Bracelets, Plate and Sterling Silver; Hat, Hair, Stick, Scarf and Bib Pins; Plated Sword Corsage Pins; Bracelet and Eye-Glass Chains.

In Sterling Silver Novelties, all warranted Sterling Silver are: Garters, Collarettes, Pocket Combs. Tie Holders; Belts with Silver, Pearl and Tortoise Shell Buckles, Paper Cutters and Weights, Match and Stamp Boxes, Trays, Letter Clips, Letter Openers, Book Marks, Prayer Book Marks, Thermometers and Calendars, Satchel Tags, Hat Marks, Coat Hangers, Souvenir Spoons, Umbrella Clasps, Pearl Teething Rings and Rattles, Glove Hooks, Button Hooks, Glove Stretchers, and Hat Buckles, Hair Pins in Celluloid, Real Tortoise Shell, Silver Mounted; Tooth Brushes, Shoe Horns and Letter Seals, Mirrors, Game Counters, Cigarette Cases, Sword Corsage Pins, Key Ring Chains, Bonbon Spoons, Pocket Knives, Scissors, Razors, Manicure Articles, Gold and Silver Mounted Suspenders, Novelties in Leather Card Cases, Memorandum Books, etc.; Stag Handle Cutlery Novelties, Corkscrews and many others.

The company issued last year one of the finest illustrated catalogues ever put out by a jewelry house and another is now in preparation which will be even better than

**THE KENT & STANLEY CO.**

its predecessor, if that is possible. The business of the present Kent & Stanley Co. was first established in 1873 under the style of William H. Robinson & Co.,

**THE KENT & STANLEY CO.**

surviving partners, Edwin F. Kent and Arthur W. Stanley, under the old firm name. In 1887 these gentlemen purchased Mrs. Robinson's interest and continued under the style of Kent & Stanley. Under the new impetus, business during the two following years was doubled, but on Feb. 19, 1888, another fire once more interrupted operations by burning the factory entirely to the ground. Another shop was immediately found by Mr. Kent, and by noon of the day following the fire new machinery was already being put in position at the new shop, an instance of his indomitable will and prompt action in an emergency to which is due in a large measure the firm's success and high position to-day.

A lease of the ground on which the burned building had stood was quickly secured, and without the least unnecessary delay, Kent & Stanley began the erection of a building suitable to the needs of jewelry manufacturers which, when completed, ranked among the best factory buildings in the city. The firm took up its quarters in it and continued with increasing success. In February 1891, it was incorporated, under the title of the Kent & Stanley Co., being capitalized at \$300,000, represented in real property, and with charter rights for half a million. In November, 1893, the constantly increasing business necessitated larger quarters and the balance of the treasury stock was issued. In July, 1894, this additional stock had been issued, paid for in cash and invested in the new plant, which forms the subject of this article. It represents an investment of about \$350,000, and the total capital and surplus of the company in-

at 25 Calendar St. and the output consisted of chains. In 1882 Mr. Edwin F. Kent became a member of the firm and at once took an active interest in its welfare. In 1884 occurred the disastrous fire still remembered by the citizens of Providence, in

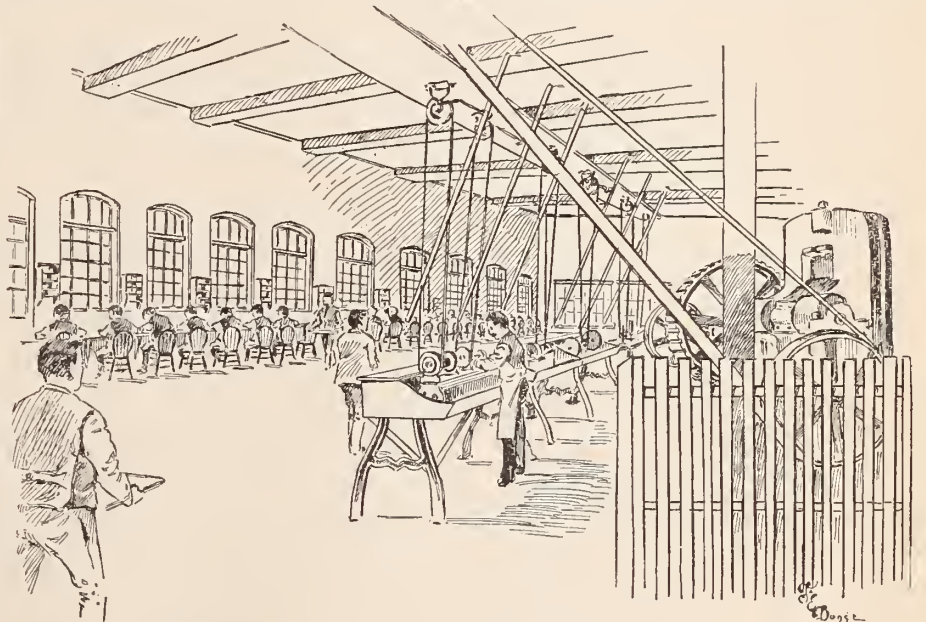

A CORNER IN THE SILVER SHOP.

which the factory was destroyed. New quarters were found at 7 Eddy St., and operations were again resumed. In 1885 Mr. Robinson died, and for nearly two years the business was conducted by the

vested in business is \$650,000. Its officers are: president, A. W. Stanley; treasurer, E. F. Kent; vice-president, J. S. Ingalls; secretary, J. D. Warren. George R. Clarke is superintende it and designer.

The similarity and the difference between the two are plainly apparent.

\*

The foregoing advertisement from Columbia, S. C., is commendable for the display and for the cheerful, optimistic tone which pervades it. It is a theory of mine that all advertising should be cheerful, that there should not at any time be a suggestion of anything unpleasant. That all mention of hard times should be rigidly excluded. This ad. is a little bit flippant, and one has to look at it pretty closely to find out what it is all about. Otherwise it is first-class. Every ad. ought to show on the face of it what it is talking about. This does not mean that the word "jewelers" and the dealer's name should be the biggest things in the ad. They should be prominent, but not obtrusively so.

#### Max Freund & Co. Sue Braverman & Bostelman.

SAN FRANCISCO, Cal., Jan. 1.—United States Marshal Baldwin has been appointed by United States Circuit Judge McKenna to take charge, as receiver, of the proceeds resulting from the sale of diamonds which recently formed part of the stock of Braverman & Bostelman, jewelers, doing business in this city. The diamonds had been deposited with the First National Bank of this city, in the name of Louis Braverman, a relative of one of the firm.

This action is the result of a suit begun in the United States Circuit Court by Max Freund & Co., New York, who allege that through fraudulent representations, Braverman & Bostelman obtained from them and other New York merchants, whose claims have been assigned to Freund & Co., diamonds valued at \$35,500; that the diamonds were converted into money and book accounts, and the same fraudulently transferred to Louis Braverman. Judgment in the sum of \$35,500 is prayed for, and it is demanded that Braverman & Bostelman be convicted and punished for the perpetration of a fraud.

Braverman & Bostelman failed several weeks ago. The men composing the firm came here from New York, where they had been engaged in the jewelry business two years ago.

#### J. T. Scott & Co. Lose a Suit in the Los Angeles Superior Court.

LOS ANGELES, Cal., Dec. 29.—J. T. Scott & Co., New York, were defeated in a suit in the Los Angeles Superior Court. They had levied an execution on the stock of goods in the store of Platt & Harris to satisfy a judgment obtained against the firm of Harris & Dukeman. The goods belonged to Harris & Dukeman, and it is claimed were hypothecated to one Bryson, a physician, to secure a loan of about \$2,000 to the Harris & Dukeman firm, but which Scott & Co. claim was only a scheme to defraud them amongst other creditors.

Bryson procured judgment against Harris & Dukeman and sold the goods on execution. He bought them in himself and subsequently put them in the store of Platt & Harris as he says "to sell for him." Harris had meanwhile dissolved from Dukeman and formed a co-partnership with Platt so he was again coming into possession "for sale" of his own goods. The court adjudged that there was not sufficient proof of Bryson's fraud apparent.

#### Sumner Blackinton Dines Members of the Trade.

An enjoyable dinner was recently given at the Café Savarin, under the Equitable building, New York, by Sumner Blackinton, of W. & S. Blackinton, to Fred. Kaufman, 41 Maiden Lane, and two of his travelers, A. Halzinger and M. Wolfe. Lively conversation, an excellent menu and superior wine contributed toward making the evening one which the guests will not soon forget. The remembrance of this dinner will no doubt be so pleasing that should the famous W. & S. B.★ chains get a boom through the efforts of Messrs. Halzinger and Wolfe the trade need not be surprised.

#### Poor Business Causes Henry G. Booth to Assign.

ROCHESTER, N. Y., Jan. 3.—Henry G. Booth, jeweler doing business at 9 State St., in the Powers building, made a general assignment this morning to Charles M. Oviatt for the benefit of his creditors. No preferred creditors are named. For several weeks past Mr. Booth had been selling off his stock at auction and had disposed of the greater part of it. The assets and liabilities are unknown, but it is thought the assets will not be inconsiderable.

Mr. Booth had conducted the store on State St. for many years. He succeeded his father, who began business in this city forty years ago. Poor trade is the cause of the assignment.

#### Creditors Claim That Mrs. Sarah M. Feiga Wants to Defraud Them.

WORCESTER, Mass., Jan. 4.—Deputy sheriff James Early has attached the store of Mrs. Sarah M. Feiga, jeweler, 270 Main St., for \$1,000, at the instance of Johnson & Gillespie, Boston, and placed a keeper in charge. The case is one of contract, the writ being returnable in the Central District Court.

Mrs. Feiga's husband is Max Feiga, who has done business in the city for a number of years, and she has taken out a married woman's certificate and does business in her own name. On Dec. 24th she mortgaged the store to Barnett Wolkowich for \$850, and the attaching creditors allege that this was done to defraud her creditors. Several of the creditors have formed a combination to contest the validity of the mortgage and they will attempt to annul it if possible.

#### Rogers & Bro. Stop An Infringer From Using Their Trademark.

PHILADELPHIA, Pa., Jan. 1.—Rogers & Brother, Waterbury, Conn., and 16 Cortland St., New York, brought an equity suit in Court No. 4 against Harry Friedman, who is engaged in business at 630 Arch St.

The bill of complaint sets out that the plaintiffs are using the trademark, "Rogers & Bro." on all their ware, to distinguish it from that manufactured by competitors in the same business throughout the country, and on second quality goods they use the mark "R. & B." Friedman, who is trading under the name of the Consolidated Silver Plate Co. has been stamping goods of his own manufacture with the mark "R. B. Quad. Plate," which, the plaintiffs say, has had the effect of misleading purchasers, and inducing them to believe that the goods were manufactured by their company. They asked for an injunction restraining Friedman from making any further use of the mark. Friedman filed an answer, in which he admitted the facts set forth in the bill, and expressed his willingness to desist in the future from using the mark complained of, and Judge Wilson made an order enjoining him from doing so.

#### The Cruiser "Minneapolis" to Receive a Silver Service.

MINNEAPOLIS, Minn., Jan. 3.—The cruiser *Minneapolis* is to receive from the city, a fitting and appropriate gift—a gift worthy of the city and her swift namesake. The executive committee of the cruiser ball met Dec. 29 to sum up results. The committee consists of Mayor Eustis, C. McC. Reeve, J. F. Conklin, Lucian Swift and George B. Eustis.

After looking over the finances they decided that they were warranted in ordering a \$5,000 silver service. It was further decided to order the service of the Gorham Mfg. Co., Chicago, through Eustis Bros., of this city. The designs for the service have already been prepared, and will produce a service ornate in the extreme. There is a suggestion in them of Minneapolis, industry and energy, and the largest piece will have a representation of Minnehaha falls, which are everywhere identified with Minneapolis. It will be a 10-piece silver service. The most prominent piece is a tureen and stand of massive design and superior workmanship. It will be surmounted by a cover of uniform design. There will also be two large vegetable dishes, with covers; two gravy dishes, an 18 inch meat dish and another somewhat larger.

The whole will constitute a service as fine as any which has been given to any of the white squadron, so that Minneapolis may feel that she has done as well by her namesake as any of her competitors for the honor of a name. As the designs are in hand, it will not be long before the service is ready for presentation.

### Last Rites to the Memory of George Wilkinson.

PROVIDENCE, R. I., Jan. 2.—All that was mortal of George Wilkinson was laid at rest yesterday afternoon with simple yet impressive ceremonies, which testified in a measure to the esteem in which he was held by all who were so fortunate as to have his friendship or acquaintanceship. Hundreds of all classes were at his bier to take their farewell of a man who was of inestimable benefit to the community and his fellowmen.

A private service was held at his late residence, 77 Melrose St., at 1.30 o'clock, conducted by Rev. Thomas D. Anderson, D.D. The body was removed to the Central Baptist Church, followed by a cortege of mourners, and at 2.30 o'clock a funeral service was held, conducted by the pastor, Rev. Dr. Anderson. The service was brief and unostentatious, consisting of an address eulogistic of the labors, virtues and life of Mr. Wilkinson, and the rendition of several hymns by the choir. The church was crowded, among the attendants being 800 of the employes of the Gorham Mfg. Co. A portion of the church was set apart for them and by a systematized arrangement they passed before the bier of their beloved superintendent. The scene was a solemn one, as these men passed before the bier, many of them being affected to tears.

The floral tributes were not numerous, as

Mr. Wilkinson had requested that no great display be made in this way, and his wishes were respected. There were, however, several floral testimonies of the esteem in which he was held. His taste in this matter was observed in the few choice tributes presented. Prominent among the tokens was a prettily designed floral piece from the employes of the works.

The gentlemen who served as honorary bearers were: Edward Holbrook, president of the Gorham Mfg. Co.; vice-president George H. Robinson; Frederick Grinnell, a director; secretary John F. P. Lawton; Lucien Sharpe, of the Brown & Sharpe Mfg. Co.; Gilbert A. Phillips, of the Manufacturers' National Bank; George E. Martin, of the Phenix National Bank and William P. Chapin, of the Rhode Island Locomotive Works, and the four oldest foremen of the Gorham Mfg. Co., who had been with the deceased for more than 25 years, Joseph Baker, H. C. Bushnell, William Hughes and Sanford Bodwell. There were many prominent people present from outside of the State, among whom were: Messrs. Albert Caldwell, Wheeler and Thomas representing J. E. Caldwell & Co., Philadelphia; Geo. H. Wilcox, of the Meriden Britannia Co.; John Hoare, Corning, N. Y.; J. H. Buck, New York; Mr. Southworth, Benedict-Burnham Mfg. Co., Waterbury, Conn., and many others. There were also a large number of men identified with the city and State business and local business houses.

At the conclusion of the services, the funeral cortege wended its way to Swan Point Cemetery, where the interment took place.

### To Make an Example of a Receiver of Stolen Property.

PROVIDENCE, R. I., Jan. 4.—The second of the young men accused of stealing gold stock from Waite, Thresher Co., has come into court and pleaded *nolo contendere*, and like the first has been placed under the nominal bond of \$500. It now remains for John Nelson, the member-at-large of the House of Representatives from this city, to come to the bar of the Common Pleas Court and plead to the indictment alleging that he received stolen goods. The course that the Attorney-General has taken in accepting pleas of *nolo*, and in asking for light bail, gives rise to the assertion that he intends to make an example of Nelson and to use the young men as the chief witnesses against the purchaser of the stolen gold scraps.

The manufacturing jewelers are watching this case even more closely than are the politicians from the fact that for several years past they have been the victims of thieves who have stolen large quantities of gold scrap. Although several of these operators have been apprehended and sentenced, the authorities have failed to discover where they disposed of their stolen goods and it is thought that Nelson has

# JONES & WOODLAND,

Late of the Firm of  
LARTER, ELCOX & Co.

On January 1, 1895, we started up our New Factory and Office  
at 49 Chestnut Street (Krementz Building), Newark, N. J.

OUR LINE will comprise Children's, Ladies' and Gentlemen's PLAIN AND FANCY RINGS. A large assortment of IMPROVED SPRING BACK STUDS in new designs; LINK BUTTONS, STONE SEALS, etc.

The Superintendent of our Factory is Wm. C. Woodland, for 30 years Superintendent for the old firm.



WILLIAM H. JONES,  
THEODORE M. WOODLAND.

been one of the principal avenues through which such material has been handled.

#### Tax Assessments on Connecticut Manufacturers.

NEW HAVEN, Conn., Jan. 5.—As shown by the new tax lists just out the Barbour Silver Co., Hartford, pay taxes on \$29,000; Alderman William H. Watrous, Hartford, personally \$33,700; The Biggins-Rodgers Co., Wallingford, \$22,000; the G. I. Mix Co., Yalesville, \$50,000; Maltby, Stevens & Curtiss Co., Wallingford, \$40,000; E. Maltby personally, \$33,285; H. L. Judd Co., Wallingford, \$65,400; H. L. Judd personally, \$40,413; Simpson Nickel Co., Wallingford, \$34,000; Samuel Simpson estate, \$72,302; Simpson, Hall, Miller & Co., \$134,322; R. Wallace & Sons Mfg. Co., \$130,000; F. A. Wallace, \$19,648; J. D. Bergen Co., Meriden, \$10,000; E. A. Bliss Co., Meriden, \$20,000; Bradley & Hubbard, Meriden, \$28,450; Bradley & Hubbard Mfg. Co., Meriden, \$335,000; Bradley & Hubbard Mfg. Co., and Meriden Britannia Co., \$27,250; N. L. Bradley, \$51,800; Chapman Mfg. Co., Meriden, \$35,000; George M. Curtis, Meriden, \$13,420; Samuel Dodd,

Meriden, \$16,944; Walter Hubbard, \$123,502; Isaac C. Lewis estate, Meriden, \$54,900; Manning, Bowman & Co., Meriden, \$130,100; Meriden Britannia Co., \$794,000; Meriden Bronze Co., \$64,500; Meriden Cutlery Co., \$196,150; Meriden Silver Plate Co., \$127,500; Miller Bros. Cutlery Co., Meriden, \$49,610; Edward Miller, Meriden, \$53,540; Edward Miller & Co., Meriden, \$242,675; Monroe Mfg. Co., Meriden, \$15,000; Chas. Parker, Meriden, \$37,500; Charles Parker Co., Meriden, \$420,820; Parker Clock Co., on \$19,580; Charles L. Rockwell, Meriden, \$16,050; C. B. Rogers, \$10,250; C. Rogers & Bros., \$78,450; George H. Wilcox, \$19,075; H. C. Wilcox estate, \$200,875; H. S. Wilcox, \$34,900; Wilcox Silver Plate Co., \$240,100.

#### To Change the Jewelry Manufacturing Center of Providence.

PROVIDENCE, R. I., Jan. 3.—It is understood that Kent & Stanley Co. have under way plans for a series of brick buildings to be erected adjoining their present new structure on Mason, Beverly, Aborn and Sabin Sts., and to cover the entire estate located between Mason and Sabin Sts.,

down to the junction of Cove St. The concern, it is stated, obtained an option on the land sometime ago, aside from the new Talcot building, which abuts on the new Kent & Stanley Co. building on the Sabin St. side, and this, of course, will remain intact. The other premises include several large old brick buildings and a number of wooden buildings so that in addition to Beverly St. the proposed new buildings will extend across Callender and Mathewson Sts., to Cove St.

It is stated that the plan is to concentrate the business of manufacturing jewelry to this section of the city and the ground floor of each building will be fitted for stores, where the wholesale trade will be carried on. At present the center for jewelry manufacturing is on Eddy St., and the lower portions of Pine, Friendship and Clifford Sts., but Kent & Stanley Co., with an eye to the completion of the new depot, the removal of the freight yards and the general cleaning up of that section of the city, are convinced that it will be very advantageous to have the manufacturers of jewelry goods confined in a large measure to that locality, and that other firms will be quick to recognize this. The alacrity with which manufacturers leased rooms in their new seven story building is considered an evidence of what they think of the location and the additional advantages to be gained by the completion of the proposed terminal facilities.

Mr. Kent was interviewed upon the subject but had nothing of a definite character which he cared to give out.

#### Members of the New York Jewelers' Association Honor Dr. Brown.

A handsome diamond and pearl pendant was presented last week by a number of the members of the New York Jewelers' Association to Miss Rosa M. Brown, daughter of the Rev. Jno. W. Brown, upon the occasion of her marriage to Mr. Crichton, which took place Saturday, at St. Thomas' Church, Fifth Ave. and 53d St., New York. The pendant was accompanied by a beautiful testimonial to her father, the Rev. John W. Brown, bound in white kid lined with satin and signed by the donors. The testimonial was a triumph of the artist's skill and read as follows:

REV. JOHN W. BROWN, D. D.

DEAR SIR:—A few members of the New York Jewelers' Association with pleasure embrace this opportunity to convey to you an expression of their respect and esteem and to present the accompanying token to your daughter on her approaching marriage with the hope that you and Mrs. Brown may long be spared to each other, and to New York, that your beneficent life work exert an increasing influence for good and that your daughter's new home may become a center of gracious influences worthy of her girlhood's surroundings. We offer our united congratulations subscribing ourselves,

Very sincerely yours,

J. B. Bowder & Co.,	Unger Bros.,
Krementsz & Co.,	Spencer Optical Mfg. Co.,
L. Lelong & Bro.,	Ino. R. Keim,
C. G. Alford & Co.,	Geo. W. Shiebler Co.,
Wilcox Silver Plate Co.,	Dominick & Haff,
Randel, Baremore & Billings,	Ludwig Nissen & Co.,
N. H. White & Co.,	Howard Sterling Co.,
Hayden W. Wheeler & Co.,	Jos. F. Chattellier,
Derby Silver Co.,	Chas. F. Wood & Co.,
	Alfred H. Smith & Co.,
	Carter, Sloan & Co.

## DIAMONDS.

# Wm. S. Hedges & Co.,

## Importers of Diamonds,

And Manufacturers of DIAMOND JEWELRY.

170 Broadway, New York.

22 Holborn Viaduct, London.

# Alfred H. Smith & Co.,

IMPORTERS

## DIAMONDS

AND

## PRECIOUS STONES,

82 BROADWAY, COR. JOHN STREET,

NEW YORK.

83 Holborn Viaduct, London, E. C.

# R. A. KIPLING,

## Precious Stones

AND Fancy Goods

Bought and Sold on Commission.

19 RUE DROUOT,

PARIS, FRANCE.

## ONE YEAR'S SUBSCRIPTION

—TO—

## The Jewelers' Circular

—At \$2.50,—

Entitles the subscriber to a copy of "WORKSHOP NOTES" free, a 200 page book, bound in cloth, containing a fund of information for the workshop that can be found in no other work.



**The Scope of the National Association to be Made Clear to Mass. Jewelers.**

WORCESTER, MASS., Jan. 4.—The adjourned meeting of the Retail Jewelers' Association of Massachusetts was held at the Board of Trade rooms, in this city, yesterday afternoon. There were present about 40 jewelers from all parts of the State and much interest was manifested in the proceedings of the day. Although the meeting was attended by the representatives of the State Association it really was a gathering of the members of the Worcester county branch. President R. E. Eldredge, of Milford, was in the chair.

Arthur S. Goodman, president of the National Association, delivered an address on the subject of "Trade Abuses." John Wilson, of the firm of Wilson Bros., Boston, spoke on the advantages of organization, and Albert J. Byrne, of the same firm spoke of the advantage of affiliating with the National Association. E. M. Dickinson, of North Adams, spoke on "Local Abuses." The following resolution was adopted by the association:

*Whereas*, Considerable misunderstanding exists relative to the true scope and efficiency of the National Retail Jewelers' Association, therefore,

*Resolved*, That we believe it due to the best interests of our trade that the association should avail itself of every opportunity of correcting such impressions. While it is not our desire to recommend the efforts of self, or attempt to affect other organizations, we are of the opinion that a vote of organization should be taken to instruct officers to attend the adjourned meeting of the Massachusetts Jewelers' Association, to be held at the Chamber of Commerce building, Boston, Tuesday, Jan. 15, 1895, at 2 o'clock P. M., and endeavor by all proper means to secure the co-operation of such men of the craft as are not members of this association.

On a motion the following members were appointed a committee on by-laws. Albert J. Byrne, Boston; Frank French, Orange; George O. Foye, Athol. It was voted to send delegates from the National Association, headed by the president, to the National Association of Jobbers in American Watches next month. The following board of directors was announced by the chair: E. M. Dickinson, North Adams; James H. Connor, Lynn; John Wilson, Boston; R. B. Johnson, Waltham; Alvin Bruce, Worcester.

Many applications for membership were made and the following were voted in as members: C. F. Pettingill, Quincy; Hill & Son, Beverly; William Bond & Son, Boston; L. M. Barnes, North Adams; W. J. Larcher, Webster; H. G. Hudson, Amesbury; F. H. French, Hopedale; G. H. Whittemore, Milford; W. E. Hobb and G. C. Clapp, North Brookfield; C. J. Holden, Waltham; L. E. Higley, North Adams; R. B. Johnson, Waltham; E. M. Dickinson, North Adams; Wilson Bros., Boston; A. E. Rogers, Fitchburg; D. E. Gray, Warren; M. E. Tobey, Great Barrington; Edwards Jewelry Co., F. A. Robbins, W. L. LaRue and T. H. Richardson, Pittsfield; L. W. White, North Adams, and F. H. Roberts, Adams.

N. H. Savage will shortly open a jewelry store in the Hoos building, Liberty, N. Y.

ESTABLISHED 50 YEARS.

RANDEL, BAREMORE & BILLINGS,

IMPORTERS OF

DIAMONDS,

AND OTHER PRECIOUS STONES.

FINE PEARLS A SPECIALTY.

MANUFACTURERS OF

DIAMOND JEWELRY,

IN THE LATEST DESIGNS.

Diamonds Recut in Modern Styles or Repaired on Premises.

58 Nassau Street,  
29 Maiden Lane,  
NEW YORK.

1 Tulp Straat,  
AMSTERDAM.

1 St. Andrews St.,  
Holborn Circus,  
LONDON, E. C.



TRADE MARK.

ESTABLISHED 1841.

CARTER, SLOAN & CO.,

MANUFACTURERS OF GOLD JEWELRY,

No. 15 MAIDEN LANE,

NEW YORK.

A. CARTER JR.  
A. K. SLOAN.  
C. E. HASTINGS.

GEO. R. HOWE  
WM. T. CARTER  
WM. T. GOUGH.

FACTORY, NEWARK, N. J.



JOHN N. DISSELKOEN,

Cutter and Importer of

DIAMONDS

FACTORY  
73 LANGEBLEEKERSPAD  
AMSTERDAM.

19 East 16th St.,  
NEW YORK.



## BUSINESS IN 1894 AND PROSPECTS FOR 1895.

INTERVIEWS BY THE JEWELERS' CIRCULAR'S CORRESPONDENTS WITH PROMINENT DEALERS THROUGHOUT THE COUNTRY.

### Prognostications of the Jewelers of the Garden City.

CHICAGO, Ill., Jan. 2.

The year has been one of close calculation with manufacturers, jobbers and retailers alike. Several causes have contributed to this result, chief among which was the uncertainty born of the business depression of the previous year. Delayed legislation of the tariff schedules tended to prolong the uncertainty and delay restoration of confidence. While directly the tariff would affect few lines as compared with the aggregate of those carried by jewelry houses, procrastination in passing a bill aided indirectly in strengthening the conservatism of dealers and kept purchasers within the bounds of actual trade necessities. This resulted in smaller orders than had been usual, which, after all, was not an unmixed blessing, as it enabled the retailer to scale down his bills payable and brought all branches of the trade well within their lines of credit. Losses the past year have been less than those of former years, and the trade from top to bottom is regarded as sound financially. Books of leading conservative jobbers indicate a loss from the previous year in jewelry lines of 15 to 20 per cent. Up to September there was a great falling off, but the last four months of the year showed a slight increase, with the close of the year unexpectedly strong.

In watches the distribution has been much less than in 1893, and manufacturers compare the year with 1873 as one of the worst in recent years. Up to August there was a very large decrease. In August an improvement was noted. The factories were then running five days a week and only half force, but the stock of goods on hand was sufficient to carry the companies through the succeeding months without increasing the factory forces. Since last August there has been a constant increase. The Elgin National Watch Co. turned out an average of 1,000 watches a day for the year.

The records for plated ware houses are widely divergent, ranging from a fair increase to a decrease of 20 per cent. from 1893 trade. Possibly an average would show a slight increase. In hollow ware the tendency of the manufacturers is toward a lower grade of goods, and those who have filled the demand for this class have had an excellent trade. While the higher grades nearly held their own, the lower grades sold better than formerly. There was a 15 per cent. increase in the dollars and cents of the sterling silver houses, and when the price reduction of Jan. 1, 1894, is taken into consideration this shows a volume of distribution fully 25 per cent. in excess of 1893.

Clock houses report a satisfactory year and a large increase in sales during the last six months. About a 15 per cent. increase is shown in dollars' worth sold, and from 20 to 25 per cent. in quantity of goods moved. Clocks are being sold on closer margins and are in good demand. Other lines show decreases for the year of from 5 to 20 per cent.

Following are given the opinions of leading jobbers as to the prospects for 1895:

Benj. Allen: "The unsettled condition of the currency is bound to keep general business retarded for a while. We look for a slight but gradual improvement from now on. As near as we can learn from our customers, they have done better this holiday season than they did a year ago, and the chances are they will be more inclined to buy. The retailers had a business scare and felt like going slow. There are now just as many resources of all kinds, just as much property, as during the boom of three years ago. We think the outlook is for a gradual but, perhaps, slow improvement.

Manager Prentiss, Gorham Mfg. Co.: "I think 1895 will be a better year in silver than even in 1892. The people are getting in better shape, there are a less number of unemployed, and the savings banks in December showed a large increase in deposits, something quite unusual for that month. The purchasing

power of the people has increased and is increasing, and this will result beneficially to all lines. We have not had in five years so many orders after the holidays and I believe it will continue."

Lem Flershem: "Future? I've quit guessing."

C. H. Knights: "Prospects for 1895 are much brighter than were those for 1894. Prices are holding steady and there is a better feeling among the retailers—a general restoration of confidence. Another item that cuts a figure is the reduced stocks. Any general improvement is always productive of increased sales and the market to-day shows a marked improvement. We haven't had a year in ten years with the losses so small as in 1894, and regard the business outlook as better now than for eighteen months past."

President Avery, Elgin National Watch Co.: "I look for a good condition of affairs when the industries improve. At present they are all low. I would not attempt to make any further forecast of the future."

Manager Barnum, Ansonia Clock Co.: "I have talked with dealers and find our customers have done a first-class business. Customers write me to the same effect. They all seem much encouraged. If we have an increase over 1894 of 12 per cent., we should consider it our just dues. This we expect."

Mr. Meacham, manager of credits, Meriden Britannia Co.: "We all look for a very good trade in 1895. In 1892 credit was so extended that many were really doing business on borrowed capital. They are now well within their own capital and the question of credit is hardly criticized as sharply as it was, which will assist toward a better feeling. The result will be a steady increase of sales."

Tools and material and findings dealers expect jobbers generally to stock up the early part of the year.

### Quaker City Jewelers Optimistic Regarding 1895 Trade.

PHILADELPHIA, Pa., Jan. 5.

As stated in a previous issue of THE CIRCULAR the Philadelphia houses were agreeably surprised at the wonderful amount of trade that attended the holidays. While the local jewelers, silversmiths, etc. agree that last year's business was unprecedentedly dull, the prospects of the coming year are generally optimistic. Much of the briskness of the dying year is explained by the fact that retailers found themselves short of stock and the demands upon manufacturers and wholesalers were therefore excessive. Below will be found the opinions of some of Philadelphia's representative men in the trade:

Edwin S. Simons, of Simons, Bro. & Co., said: "Speaking of last year from January to July was very dull, and from July to January was very busy. There were two causes in my opinion for this: returning prosperity, and the fact that the trade the previous Fall didn't buy any goods and found themselves short last Fall. I don't think this briskness was an indication of a greater consumption of goods. The retailers did not buy, and when the trade did come they had not prepared for it and they had to get the stock from the manufacturer. We seemed to have just the goods they wanted, and we were never cleaned out as much as we were last year. During the holidays we were very busy and worked early and late, and we had a far better retail trade than a year before. For 1895 the Spring will be better than a year ago, and the Fall will be better than that of 1894. We are ready for a big business for the year. We think the jewelry trade is in better shape to-day than it has been for years, because it is not overstocked, and they are better able to pay their bills."

H. Diesinger, of Hamilton & Diesinger, has this to say: "The number of people we handled during the

holidays was simply wonderful. We not only went ahead of last year, but we did the largest business in our history. The tendency was towards small goods, the large goods staying with us. But the business, as a whole, was remarkable. I believe there will be fewer failures in the trade this year than there were last. From inquiries I have made of men who are versed in its condition, their ideas coincide with mine. Collections are a very little bit closer, and that is a healthy sign. Everybody is worked out of stock, and I think there will be a still better trade this year than last."

Wm. P. Sackett, president of Sackett & Co., states: "Our Christmas trade was very satisfactory. The holiday business came, of course, very late, but the volume of it was larger than we anticipated. The year, as a whole, was very quiet on account of the business depression. Philadelphia felt this more than any of the larger cities on account of being more interested in manufactories. During 1895 I look for a gradual return of good times, but I don't think there will be any boom. I believe we are over the worst of the depression, and, of course, we are all glad of it."

B. F. Williams, of D. F. Conover & Co., expresses his views as follows: "Trade during the year of 1894 was not good, but during the month of December it improved very much. Our collections are better than usual at this time of the year, and I think the retail trade generally feels much encouraged. The prospects of business in 1895 are better than they have been during the past two years."

George Eakin, of Geo. Eakin & Son, says: "The holiday trade was particularly good, and considering the hard times and everything else the business of the year generally was very fair. I don't see how it could be better. It is impossible to speculate on this year, but we hope to do better. But after all there is no reason why trade should be better this year than it was last."

George W. Scherr, of L. A. Scherr & Co., regards the prospects in the jobbing trade as decidedly flattering. "The anticipations for 1895," he says, "are particularly good. The great majority of houses in the trade are short of goods, there is a good demand for stock, and so far money is coming in very liberally. Business during the early part of last year was dull—and it was dull all around—but towards the end it picked up wonderfully and in December it was marvelous. The demand was for small articles, and this branch appears to have ruled every grade in the business."

C. Huber, of the McAllister Optical Co., expresses himself as follows: "Our general trade for the year was better than in 1893. There were more goods sold and they were of a better quality. Ninety-three's business, however, was very small. Our Christmas trade was not anything to brag of, but the rest of the year, comparatively, was satisfactory. Ninety-five is very young, and it is difficult to anticipate it. The factories up-town are not now in a very prosperous condition, and unless things pick up in the Spring, we don't expect anything better than last year. Then there is the importing element. If the extent of the importations affect the manufacturers, as I fear it will, it will affect us also. We don't feel that cheap goods will be specially profitable to us."

### Prosperity the Order of the Day in Kansas City.

KANSAS CITY, Mo., Jan. 4.

The past three or four weeks have sorely tried the capacity of the retail stores, the holiday season just passed having been the busiest the jewelry trade has seen in four years. It opened as early as the first week in December, and steadily increased until the

few days immediately preceding Christmas, when some retail stores were busy until after midnight. The year as a whole has been very good, far surpassing the year before. There has not been much demand for the more expensive articles, but the number of sales more than doubles the preceding year. The general outlook for the coming year is one of security, and if expectations are fully realized 1895 will far surpass 1894.

Cady & Olmstead's sales were the same as last year. In the early Spring trade was far ahead of the preceding year, but the hot Summer showed a marked decrease. For the holiday trade diamond sales were tolerably good, while sterling silver table ware was far ahead of any previous year. Outlook for the future is encouraging.

The J. R. Mercer Jewelry Co. run ahead of last year by 20 per cent. during the entire year, with the exception of July and August. Their diamond sales for the holiday season compare well with any previous season; sterling silver novelties sold very well. Mr. Mercer is fully satisfied that the next year will see trade far ahead of any previous year in this city.

F. W. Meyer was busy day and night during the holidays and almost in the same condition during the whole year. Cut glass ware has far outdone any other season and the trade in silver novelties has been exceptional.

The past year has been one of unparalleled success with the Jaccard Watch & Jewelry Co. Their aggregate sales for the year were over 30 per cent. more than the preceding year. Silver novelties seemed to have been in greater demand than ever before, while expensive articles and diamonds compare favorably with the last two years. The firm seem well pleased with prospects for the coming year, and are making extensive preparations for handling a much larger stock.

### Syracuse Jewelers Pleased With Business.

SYRACUSE, N. Y., Jan. 4th, 1895.

Syracuse jewelers in general view the business of 1894 with equanimity, are well pleased with the holiday trade, and are looking forward with confidence to the year of 1895.

Joseph Seymour, Sons & Co.: "Business for 1894 better than a year ago. Fore part of the year very dull with an increase of 21 per cent. during the month of December. Prospects for 1895 very good. No great boom expected, but a gradual increase of trade during the year."

H. J. Howe: "We find a decided increase over last year in the amount of business, cash being more ready than previously; sold more watches than last year also; silver goods, of course, being the most popular, both in small and large pieces. Business opening up for 1895 very brisk, and a good trade expected. Our trade we find are buying much more confidently than last year, making the sales easier. We find solid silver flatware in great demand."

E. B. McClelland: "My business for the year 1894 has been about 20 per cent. more than that of 1893, but I regret to say not equal to that of 1892; the most conspicuous gain has been made in the December (or holiday) business, which illustrates to my mind the importance of the holiday trade to the jewelry business. I attributed my largely increased trade in December, 1894 over that of December, 1893, to the fact that the manufacturers anticipated a demand for inexpensive goods, owing to the general depression in trade; so made a line suitable to the conditions, thereby inducing the public to trade with the jeweler rather than as in 1893 going into other channels to make their purchases. I also noticed an increased demand for sterling table ware during the month. This undoubtedly was because the general public, knowing the present low price of silver and anticipating an increase used this opportunity to buy silver for family presents."

Geo. E. Wilkins: "While we do not know altogether what the business has been as compared with last year, yet there was profit we are sure. We don't anticipate next year will prove better than the past."

C. S. Ball: "The low price of silver helped the trade, but had to do an immense amount of work to keep the business up to 1894 years. While the dry goods trade do not ... the profits, they get a large

amount of the business that belongs to the jeweler and hurt us in that way to a great extent. Can't see any particular good outlook for the immediate present."

A. Lesser's Sons: "Although the year 1894 was not a very prosperous year for business, yet our sales and collections both ran ahead of the year previous by quite a decent amount. The prospects for jewelers in this section are very favorable and if watchmakers and jewelers will only display the same amount of interest and push that their neighbors (the dry goods and similar trades) do, there is no reason why they should not do a satisfying business in '95. I consider the outlook very favorable for a good business in '95."

Becker & Lathrop: "In reviewing the year past find business ahead of '93, with increased sales during the holiday season, but to a large extent of articles of smaller value. We are not prophets or sons of prophets, and so cannot give any estimate of the business of 1895 so early in the season."

C. E. Eager, Agent: "There seemed to be an increased demand for sterling silver goods, and much more was sold than in former years. Small diamond goods went quite freely. There was a greater proportion of cash sales to those of former years."

### Indianapolis Jewelers Had a Large Holiday Business.

INDIANAPOLIS, Ind., Jan 2

Indianapolis jewelers report a large volume of business for the holiday trade—a very considerable increase over the same period for 1893. The demand for silver novelties was very marked; sales were numerous, but mostly of the smaller and less expensive articles. Precious stones and gold jewelry were not in great demand. Bric-à-brac and cut glass helped the retail merchants to bring up their sales. The later half of 1894 did much to redeem the dull months at the beginning of the year. The outlook for trade during 1895 is promising; there is a general feeling, now that the "Hard Times" cry has stopped, and confidence has been restored by the result of the recent elections, that trade will gradually return to its old-time briskness.

Silas Baldwin, of Baldwin, Miller & Co., said: "Our business for the year has been very satisfactory. For the last half of '94 it was largely in advance of the year before. The last half of '93 and first half of '94 trade was very poor, but after that it was on the up grade, while the holiday trade was splendid. I consider the prospects for 1895 as very fair."

W. C. Garrison, book-keeper for Heaton, Sims & Co., in reviewing the year's business said: "Our trade up to July, 1894, was bad, but then began to pick up and each month grew better than its predecessor and better than the corresponding month of 1893, until December, when it ran away ahead and kept us busy day and night. We anticipate a good Spring trade."

Emmet Pee, of Nichols, Pee & Co.: "Our firm began business in September with a fair trade. It grew better until December, when it quieted down a little. I look for a gradual and steady increase of trade in 1895; no great rush, but an improvement over 1894."

Craft, Koehler & Co., manufacturers: "We had a fair business during 1894, but our holiday work was immense. We worked until midnight during December. We expect an increase during 1895."

Jas N. Mayhew, optician: "My business for 1894 was an improvement over 1893—sold more gold spectacles. Have nothing to complain of and am prepared for a better trade during 1895."

John Wimmer, optician: "1894 began quietly, but the last three months ran far ahead of the year before. The optical business is good and I am hopeful of an increase during the coming year—see no reason why it shouldn't come."

Julius C. Walk & Son: "Our December business was far in advance of the same month during 1893, but the entire year was not so good. Fully expect an increase during 1895."

F. M. Herron: "Trade during 1894 was fitful, but from September to Christmas was ahead of 1893. Holiday trade was very good—ahead of 1893, and equal to 1892. Can't predict the future, but hope for the best."

Horace A. Comstock: "My best months during 1894 were July, August, October. November was the

same as 1893, but December was far beyond. Holiday trade was beyond my expectations. Sales were not large, but lots of them. Since confidence in the government has been restored think we can expect good trade during 1895."

W. J. Eisele: "1894 was a trying year, but the holiday business was as good as could be expected. I was satisfied. This is a good rich country and I see no reason why trade shouldn't be better during the coming year. If people can be educated to appreciate good reliable goods the jewelers will have nothing to complain of."

### Bright Outlook Among the Jewelers of Detroit.

DETROIT, Mich., Jan. 3.

The jewelry trade of this city during the past year has been slowly but surely recuperating the strength which was lost during the Summer, Fall and Winter of 1893. At that time and later nearly every house in the city was embarrassed. One or two have gone out of existence but the rest pulled through and a visit to the retail jewelers last week revealed the fact that confidence in the future had been inspired by the excellent season just passed. As a general rule the holiday business has been much larger than was expected. When compared with the volume done the two preceding seasons, it was so much larger that all speak hopefully of a steady revival during 1895. One characteristic of the 1894 holiday business has been the large demand for silver novelties of all kinds. Those who anticipated this reaped rich harvests. An immense number of watches have also been disposed of by local dealers, not because of a healthy demand, but because the Michigan Central Railroad passed a rule requiring all its employes to purchase a timepiece of a certain quality.

Mr. Johnson, of the Johnson Optical Co., said that his firm never did a larger business since the company's organization. Trade during 1894 has steadily boomed and he predicts not only prosperity for the optical business but also for the jewelry trade.

Mr. Sturgeon, of Sturgeon & Co., stated that their business in diamonds and silverware which are the firm's specialty, by far exceeded their expectations during the last year. "I see no reason for the holding back of a prosperous year. We are anticipating such and are making preparations for it," said he.

R. J. F. Roehm said the business of the year culminated during the holidays, and that it was so excellent that he has every hopes of a continuance of the same. Trade will be naturally dull for a few weeks, but he confidently looks for a natural revival. This firm did a large business during the last year in fraternity pins and badges of all descriptions.

Henry Koester, of Kennedy & Koester, jobbers: "We had a very satisfactory Christmas business, and the year as compared with 1893 was a decided improvement. We found that the demand for high priced goods or even standard goods has decreased. We have sold a very large quantity of medium priced goods such as watches, and novelties of all kinds."

Wright, Kay & Co. say that the business of 1894 was considerably heavier than that of the preceding year, and look for an improvement from now on.

Eugene Deimel, wholesale dealer, is conservative, but states emphatically that his trade has been exceptionally good taking the prevailing conditions into consideration. He makes a specialty of watches, clocks, chains and watchmaker's tools.

At F. G. Smith & Sons, a large amount of bric-à-brac and other costly goods was moved during the holidays. Since the firm's re-organization, they have enjoyed a fair trade and express confidence that it will steadily improve after they get moved into new quarters the latter part of this month.

### Twin Cities Jewelers Generally Satisfied.

MINNEAPOLIS, Minn., Jan. 3.

Upon interviewing Mr. Bennett, of the Reed & de Mars Jewelry Mfg. Co., THE CIRCULAR correspondent found him very jubilant over last year's business, especially the Fall trade. "During the first half of '94 we did not do nearly as well as we did during the first half of '93, but our Fall trade was simply immense. In October we increased about 20

per cent., in November 40 per cent., and in December 60 per cent. over the corresponding months in '93. The fact is, we will be compelled to increase our quarters very soon. What do I think of next year? Well, we expect to do a great deal better in '95, not because business generally will be any better, but from the fact that we intend to hustle for it."

Charles Winter, of S. H. Clausin & Co., pronounced their business at 25 per cent. in gross amount ahead of 1893.

I. B. Miller Jewelry Co. enjoyed a good holiday trade, and are satisfied as this was their first season in business here.

H. E. Murdock says that trade during 1894 was not up to the former year owing to the extreme dullness in the first part of the year, when the firm did not make any effort to place goods. His holiday trade was quite fair.

Eustis Bros. pronounced trade during 1894 very satisfactory, and in volume exceeds the former year by at least 25 per cent.

The John S. Allen Co. say that trade was about the same as in 1893. A great many small sales was the rule during the holiday trade, which, in the end, did not amount to as much as was expected.

**An Era of Prosperity Among the Jewelers of the Queen City.**

CINCINNATI, O., Jan. 5.

There is greater prosperity in Cincinnati to-day than there has been in the past two years. While wages nearly everywhere have been reduced, there are less unemployed in the city than last year. The volume of trade the past month surpassed all anticipations. Though prices are lower there is a greater aggregate of sales than in '93. A vast improvement is looked for in '95. The failures of the past year were small compared to '93. The outlook is very encouraging to all branches.

The Wadsworth Watch Case Co. are a good gauge for the watch trade throughout the country. They

report general business not so good as in '93. It suffered in comparison to other lines. The cheaper grade of watches were sold. They were conservative and did not push sales as vigorously as in former years, but they have every hope that '95 will bring the dealers throughout the country in better shape and the trade will be greatly enlarged.

Clemens Hellebush reported sales in solid silver and at prices larger than in former years. His firm caught nearly all the large orders; the sales, while not numerous, were in large amounts, and the firm closed up the year handsomely.

Clemens Oskamp held his usual trade throughout the year, and had a fine holiday business. The largest number of sales were principally medium priced goods.

Oskamp, Nolting & Co., while more interested in building up a large wholesale trade, had an exceptional retail trade. During the holidays they were unable to wait on all their customers, remaining open in the evenings to accommodate them. Their sales were in everything—silverware, watches and novelties leading.

Frank Herschede's sales in every line, throughout the year, increased nearly 50 per cent. over those of 1893. His principal leaders were fine art pieces, of which he makes a specialty. Sales have improved since September steadily and the holiday rush was a revelation.

Russell Bros.' trade through the year was very satisfactory. They are judicious advertisers and reaped the fruits. They do an exclusively retail business and have a very large stock. The whole month of December was one of surprises. The firm think that 1895 will be a good trade year.

Louis Hummel has no complaint to make of past year's business. Some months were very good; two of the Summer months exceedingly dull, but there has been an improvement since September. He had an exceptional holiday trade.

Ed. G. Lohmeyer, Newport, Ky., said business in Newport was very slow, so many people being out of

work. Sales did not come up to '93.

Thos. Lovell said he was compelled to come down to the ground floor again. Since he moved to Race St. three months ago he found business picking up surprisingly. Had large watch sales.

L. M. Prince, optician, reports sales of '94 a decided increase over '93. All branches of his trade have a marked upward tendency, the increase in sales of spectacles being surprising.

John Holland Gold Pen Co. had a splendid increase in sales during the year, and expect a good trade in 1895.

E. E. Isbell & Co. report sales of '94 equal to those of '93. No visible increase except in toilet articles and silver novelties. There was a decline in sales of watches and staple articles.

**The Jewelers of Toledo Did a Flourishing Business.**

TOLEDO, O., Jan. 2.

Toledo jewelers have been very fortunate inasmuch as they suffered but little by the general depression of trade. The trade in costly goods—diamonds, watches, etc.—did suffer, but the purchases of novelties and smaller goods were brisk, and the total sales went ahead of those of 1892, which was a banner year with local jewelers. Novelties in silver saved the day, so says everyone in the trade here.

J. G. Kapp: "The past year was the best we have had since we have been in business. Our holiday trade was a surprise to us, being much larger than ever before. Silver novelties did it. Three and four times our stock was exhausted, and we had to order by telegraph to supply the demand. We kept 15 salesmen busy, with but 20 minutes for meals, during the holidays. We expect the trade in these novelties in silver will increase every year. They are just what the people want, especially for presents. From what traveling men tell me, I am inclined to believe that Toledo fared much better than her sister cities during the past year. Be that as it may, we are well satisfied

**"MOTHER GOOSE" STICK PINS.**

PATENTED NOVEMBER 6 AND DECEMBER 4, 1894.

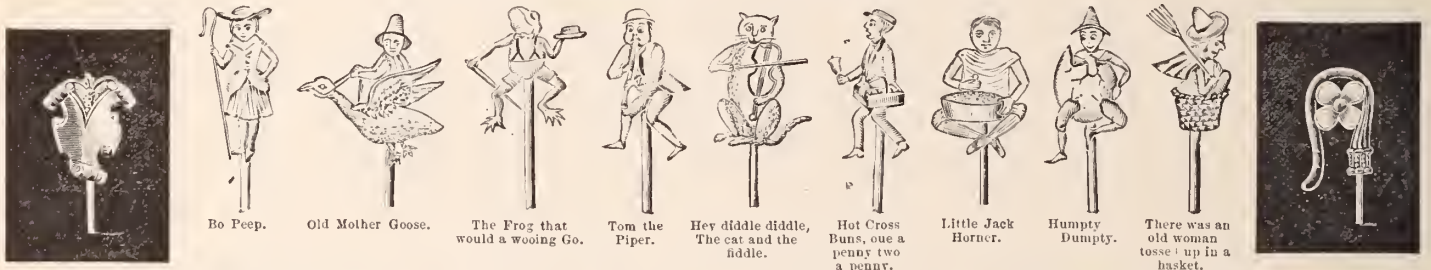

Bo Peep. Old Mother Goose. The Frog that would a wooing go. Tom the Piper. Hey diddle diddle, The cat and the riddle. Hot Cross Buns, one a penny two a penny. Little Jack Horner. Humpty Dumpty. There was an old woman tossed up in a basket.

Correct in style. Bound to sell. The best selling line of Stick Pins to date. Elegant in finish. Prices Right.

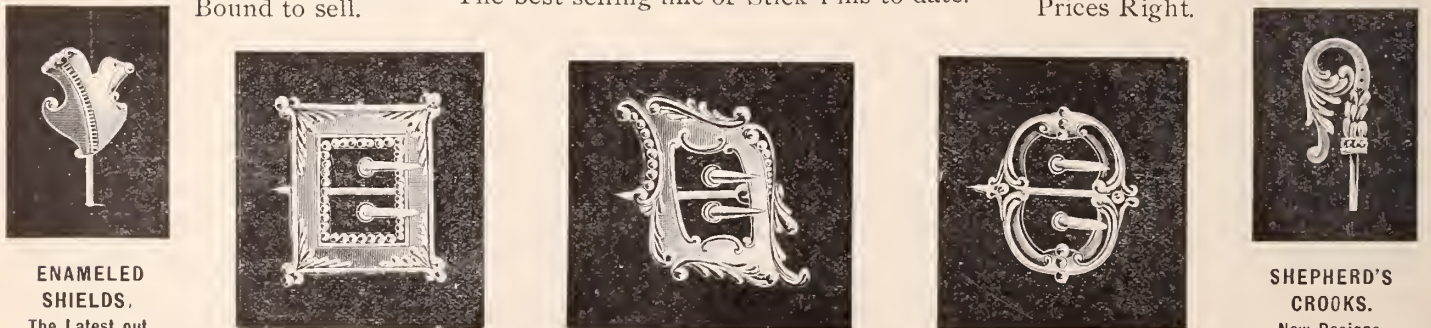

**ENAMELED SHIELDS.**  
The Latest out.  
Engraved Silver and Roman finish.  
Be sure and see them.

The Newest Fad.  
Elegantly Engraved and Enameled.

Beautiful Designs.  
Prices that defy Competition.

Finished in Silver and Roman.  
Put up in our best style.

**SHEPHERD'S CROOKS.**  
New Designs.  
Engraved Silver and Roman finish.  
Be sure and see them.

**CZARINA BUCKLE COLLARETTES**

**CZARINA BUCKLE STICK PINS.**

The Latest Novelty.

Don't Fail to see them.

GEO. F. GREENE & CO., Manufacturing Jewelers, 111 and 113 Point Street, PROVIDENCE, R. I.

with our year's work and are looking forward to a healthy increase all along the line."

J. J. Freeman: "We are well satisfied with our '94 trade; considering all things it was good. Our Christmas trade went ahead of last year. Sales were confined to smaller goods and it took many steps and much hard work. We have great store on the future. Trade is brisk now and promises to increase."

Robert Nelson & Co., wholesale jewelers, say that their business has been on a steady increase for the past six months. The year starts briskly and prospects are brighter still.

At Walcott's the holiday business was far ahead of the previous year. "What the coming year has in store for us we can only conjecture; however, it is my opinion, and I think the opinion generally that it will be one of unusual activity and prosperity. We made more sales last year especially during the holidays than ever before, but it was all in the smaller articles. The diamond and watch trade is picking up quite lively again. Even those who could have afforded these goods during the year refrained from purchasing until they saw how things were going to turn out."

Roulet & Armstrong, manufacturing jewelers, say they are experiencing a boom or they would not contemplate moving into a new commodious and elegantly fitted establishment, June 1st, when they will be located in the new Valentine building at the corner of Adams and St. Clair Sts.

L. Beckman, optician, did 50 per cent. more business during the past holidays than during any previous year and he expects business to keep up and increase steadily during 1895.

### Prospects in Lynchburg, Va., of a Roseate Hue.

LYNCHBURG, Va., Jan. 1st.

Your correspondent visited the principal jewelers in this city to-day and interviewed them on the state of trade and the prospects for the coming year. Without exception they speak hopefully. Business, the past few months, has increased in all lines, and, as a matter of course, the jewelers have felt the quickened pulse of trade to some extent. The holiday trade was larger than last year, and, in fact, better than they had reason to hope. Those who sell special lines stated that country orders were more plentiful and the goods ordered were of better grades. This is an agricultural region, and, as a matter of course, the low prices of farm products have a tendency to depress all lines of trade.

The first house visited was that of F. D. Johnson & Son. They state that the present year was away ahead of the previous one. Especially was this the case in the holiday trade. Mail orders were numerous and profitable, and they were kept busy day and night for over ten days. Their trade was 100 per cent. better than last year.

H. Silverthorn, probably the oldest active man in the trade in the country (he has been in the business over 60 years), states that his trade was much better than last year, and the holiday trade rushed him for over two weeks. The better goods were in demand.

E. A. Williams: "It gives me pleasure to state that my trade was much better than last year. Particularly was this the case in optical goods. My sales during the holidays were way ahead of last year. The better grades were called for in most instances."

J. S. Ehrick stated that his business was satisfactory, particularly during the holidays. The general tone of dealers here is healthy, and a hope that better times are in store for the future, gives the coming year a roseate hue. At least that is the impression gained by your correspondent in conversation with the dealers.

Ryland & Rankin: "Past year has been a quiet one. Taken altogether the volume of trade the past Fall was less than in '93. December business was unusually satisfactory, being in amount larger than for three years previous. We see no especially encouraging signs for '95. In our estimation much depends upon monetary legislation. If Congress will settle the financial problem business will permanently revive. Until this is done we do not look for material improvement."

### The Trade Had a Long Wanted Boom in New Bedford.

NEW BEDFORD, Mass., Jan. 2, 1895.

Like most of the cities of the country, probably, New Bedford is just now experiencing the reaction of a lively holiday trade and has settled down to the usual Spring lull. Just now a large share of New Bedford's industry is in the cotton mills. Everyone knows that this line of business has lately passed through a depressing vicissitude—in fact is not yet entirely out of it. The big strike of last Autumn, when 20,000 were for weeks deprived of income, followed the tariff uncertainty, and the city has not yet recovered from the effects. No one trade, perhaps, would naturally feel the effects as much as the jewelry trade. Therefore a marked dulness is reported here from early Fall till the present, except during the holidays. The holiday trade is stated to have been very good—in excess of the expectation of the dealers. But now they are suffering the relapse. A general feeling of hope, however, prevails and jewelers look for a brighter market in the Spring.

William L. Kelley stated that up to Dec. 12, the trade was the dullest he had ever seen. Even elections failed to stimulate it. No one seemed able to buy. But on the 13th a brisk Christmas trade struck up with startling suddenness. For two weeks it was the brightest he had ever known. The popular lines seemed to be the smaller and medium bits of jewelry and silver novelties. The demand for watches was very slight. Mr. Kelley looks for a brighter trade in the Spring, but not till then.

H. S. Francis says his trade has been as good as he could expect, generally better than last year, but not quite up to what it ought to be. The demand for the higher priced lines has been very good, but the popular goods were silver novelties.

Henry B. Howland has found his trade the best since he has been in business. The Christmas trade was better than he had expected under all the circumstances, while the staple trade was ahead of the average. Silver novelties, tags and markers were in demand, while gold rings and diamonds were by no means in poor demand. In optical goods a fair business was developed.

William F. Nye, the manufacturer of watch and clock oils, says he never had a better year in business than the past. His sales exceeded any previous aggregate for a twelve-month and as for the outlook he expects to sell just as much or more next year. The \$1,000 exhibit of his oils at the World's Fair had much to do with the increase by bringing the goods into notice. But the main reason for the stimulation is that dealers are coming to more and more appreciate the superiority of Nye's oils. Just now the works are experiencing a particular boom, due probably to the annual January replenishings of stocks after the New Year's stocktaking.

Thomas A. Tripp, president of the Pairpoint Mfg. Co., reports a rather duller trade this season than usual, except in 1893, due to natural causes. The Christmas trade was very good and the company see in prospect a brighter outlook. Cut glass has held its own very well, probably because cut glass is growing in popularity about in the same ratio that trade has fallen off.

Daniel J. Sullivan said that previous to and since the holidays a comparative dulness has prevailed, but immediately in the Christmas season business was very fair. It was fully as good as last year. The popular lines seemed to have been small articles, rings, bracelets, pins, etc., or novelties, while the larger such as clocks, bronzes and statuary, were not in great demand. For a superfluity of existence like jewelry, dealers have a very fair share of popular patronage.

Charles E. Woodworth says that while he feels satisfied with the trade, especially during the holidays, there is a chance for a marked improvement. Mr. Woodworth confidently looks for it in the Spring, but says it is dreadfully slow in coming. The Christmas demand was for silver novelties mostly, but cut glass and imported china were much called for. Diamond demand was not good, and the call for watches was positively slow.

(To be continued.)

### An Enormous Importation of White Stones.

The glittering heap which covered an area of twenty-five square feet and dazzled the eyes of a visitor to the shop of the Globe Jewelry Co.

PROVIDENCE, R. I., Jan. 9.—"It's the biggest show I ever saw in all my life." This remark proceeded from the lips of a visitor, who yesterday twined into the building at 119 and 121 Orange St., in this city, and entered the office of the Globe Jewelry Co. on the first floor.

The words were called forth by the sight of a counter piled with heaps upon heaps of beautifully cut, brilliant and sparkling white stones whose scintillating rays vied in color with every hue in the rainbow, as the observer shifted his point of view. There they lay, to the eye of the ordinary onlooker a heap of diamonds of the purest water, worth a thousand kings' ransoms and covering fully twenty-five square feet of counter room. To the uninitiated the sight was that of a lifetime, and the ephemeral pleasure of holding in one's hands a million dollars in bills, which is given privileged visitors at the United States treasury shrank into insignificance before the delight of the senses as the glitter and sparkle of the stones fascinated the eye and compelled its admiration.

With bated breath the visitor asked the reason for this apparently foolhardy display of boundless wealth, only to be told they were white stones! The very best of their kind ever produced it is true, but nevertheless only white stones, of which the firm had just imported a particularly large quantity for a certain purpose.

"And what is that purpose?" queried the visitor, still on information bent.

"To mount up in our new combinations" was the answer. "We propose to mount these stones, which have so excited your admiration, into earrings, scarfpins and studs, the latter with either spiral or separable backs, and to offer them to the trade for the sum of two dollars per dozen! These goods will be put up in handsome trays containing an assortment of six dozen of the articles mentioned, and as I see you look incredulous I want to assure you that my statement is nevertheless true. Two dollars per dozen is the price and you can therefore no longer wonder at the size of this heap of stones since that price would sell a heap many times larger. We sell to the retailer direct and save both him and ourselves the middleman's profit. The goods are neatly carded and on the cards, if desired, we print the retail price, 25 cents, a profit of 50 per cent. to the handler. Or the goods may be had on perfectly plain, blank cards.

"You'll have no difficulty in selling those goods," said the visitor, as he turned to depart.

### Eastern Jewelers Interested in New York Failures.

PROVIDENCE, R. I., Jan. 4.—Several manufacturing jewelers in this city and the Attleboros were greatly surprised upon receiving a statement from the firm of J. G. Rosengarten & Co., Philadelphia, Pa., on Wednesday, by mail. The firm ask the creditors, who are nearly all eastern manufacturers, to compromise upon all claims, in order that the firm may continue business. The firm want the creditors to accept 20 cents on the dollar on all claims for cash, or 25 cents on two notes, one for six months at 12½ per cent. and the other note for a year at 12½ per cent. If this compromise cannot be effected, the firm say they will have to close their business.

The statement rendered is a business-like document. In it the assets are given as \$16,600 and the liabilities as \$28,427. The concern consists of three hard working young men, who have been, they claim, drawing but \$18 per week salary. General business depression and poor collections are given as the cause of the embarrassment. Local jewelers, it is understood, are not yet willing to accept the compromise and will probably demand a further statement before taking any decided step.

Providence jewelers are creditors to the amount of between \$5,000 and \$6,000 in the failure of John Klipper, New York.

S. A. Gutman & Co., 51 Maiden Lane, New York, have creditors in this vicinity to

the amount of about \$6,000 to \$87,000.

Four to five thousand dollars will be the amount J. Lichtenstein & Sons, New York, owe local jewelers.

### The Death of a Promising Young Jeweler.

LANCASTER, Pa., Jan. 5.—Henry Rhoads Graff, a well-known young jeweler of this city, died yesterday afternoon at the home of his mother in this city, aged 23 years. Death was due to consumption.

Mr. Graff was a jeweler by trade, having learned it with Ernest Zahm, and subsequently formed a partnership with J. E. Sweet, manufacturing jewelers and wood engravers. Later he engaged in business alone, but overworked himself and broke down. He was a young man of many excellent qualities.

### H. M. Betz Charged With Larceny by His Father.

PHILADELPHIA, Pa., Jan. 5.—The Betz family has again come into prominence. Yesterday Frederick Betz had his son, H. M., arrested on the charge of larceny. It will be remembered that some months ago H. M. Betz, who at that time was in the jewelry business at 7th and Chestnut Sts., became involved in financial difficulties, and made an assignment to his father.

On Thursday the son went to the father's residence at Franklin and Wakeling Sts.

and loaded an office desk, account books and other articles on a wagon. He then took them to Allen's mill on Frankford Ave. and stored them. The articles came into possession of the father at the time of the assignment. When he found them gone and learned the method of their removal, he swore out a warrant and had his son arrested. He was taken before Magistrate Kochersperger, who held him under bonds for the hearing. The Betz's are very prominent people in Frankford, and the incident has caused a good deal of comment and gossip in that suburb.

The contract for the silverware for the *St. Louis* and *St. Paul*, the two new American steamships, has been awarded to the Holmes & Edwards Silver Co., Bridgeport, Conn. The competition was very close, such houses as the Gorham Mfg. Co., the Meriden Britannia Co., Reed & Barton and Holmes & Edwards participating. The last company's celebrated sterling silver inlaid quality was accepted. This company are congratulating themselves very much on the securing of this contract, as it emphasizes the excellence of this class of manufacture for the best steamship and hotel use, thus endorsing the official report of the judges of the award at the World's Columbian Exposition, which is incorporated in the government report.

THE LINE OF THE NOW WELL KNOWN

## L. E. & Co. SPRING BACK STUDS

Will be Unsurpassed  
for



PRICE, VARIETY, STYLE  
AND WORKMANSHIP.

THE INTRODUCTION OF NEW MANAGEMENT AND METHODS IN OUR FACTORY WILL ENABLE US TO MAINTAIN OUR REPUTATION FOR EXCELLENCY OF PRODUCTION, AND AT THE SAME TIME PLACE OUR GOODS BEFORE THE TRADE AT PRICES THAT WILL COMMAND ATTENTION

... WE MAKE ...

LINK BUTTONS in popular patterns at right prices.

GENTLEMEN'S RINGS with all the correct Stones, Jades, Jaspers, Corneliangs, Garnets, Etc. SIGNET RINGS.

LADIES' RINGS in the greatest variety of combinations.

CHILDREN'S RINGS in all styles.

STONE SEALS. A full line in Jades, Jaspers and Sardis.

## LARTER, ELCOX & Co.,

21 & 23 MAIDEN LANE, NEW YORK.

Factory, Cor. Mulberry and Chestnut Sts., Newark, N. J.



OUR TRADE MARK.

# The Jewelers' Circular

AND  
HOROLOGICAL REVIEW.

PUBLISHED EVERY WEDNESDAY BY

THE JEWELERS' CIRCULAR PUB'G CO.,

189 BROADWAY, NEW YORK CITY.

A JOURNAL DEVOTED TO THE INTERESTS OF JEWELERS, WATCHMAKERS, SILVERSMITHS, ELECTRO-PLATE MANUFACTURERS, AND ALL ENGAGED IN KINDRED BRANCHES OF INDUSTRY.

Our Editorial columns will contain our own opinions only, and we shall present in other columns only what we consider of interest or value to our readers. Advertising matter will not be printed as news.

Advertising rates in THE CIRCULAR are lower, considering the number of tradesmen reached by its large circulation, than in any other jewelry journal.

Notices of changes in standing advertisements must be received one week in advance; new matter can be received up to Monday.

## INFORMATION FOR SUBSCRIBERS.

### Terms of Subscription, Postage Prepaid.

	PER ANNUM.
United States and Canada, . . . . .	\$2.00
Foreign Countries in Postal Union, . . . . .	4 00
Single Copies, . . . . .	.10

New subscribers can commence at any time.

Payments for THE CIRCULAR when sent by mail, should be made in a Post Office Money Order, Bank Check or Draft, or an Express Money Order or Registered Letter. All postmasters are required to register letters whenever requested to do so.

Pay money only to authorized collectors having proper credentials.

Returning your paper will not enable us to discontinue it, as we cannot find your name on our books unless your address is given.

In changing address always give the old as well as the new one. Your name cannot be found on our books unless this is done.

We will continue to send papers until there is a specific order to stop, in connection with which all arrearages must be paid; but such an order can be given at any time, to take effect at the expiration of the subscription. All such orders will be promptly acknowledged by mail.

The Courts have decided that all subscribers to Journals are responsible until arrearages are paid in full and an order to discontinue has been received by the publisher.

## Member of the American Trade Press Association.

Vol. XXIX. Jan. 9, 1895. No. 24.

*Every line of reading matter in THE JEWELERS' CIRCULAR, with the exception of the few brief extracts from exchanges always properly credited, is written exclusively for this journal. Each issue of THE JEWELERS' CIRCULAR is copy-righted.*

THE editor of THE CIRCULAR is in receipt of an interesting communication signed "Jeweler's Clerk." As the name of the writer does not in any part of it appear, the letter does not find space in these columns. It is desirable to impress upon those persons who wish to have their communications to the editor of this journal published, that their names must be given, though their writings may be signed with a *nom de plume*.

A DESIRABLE change has been effected by the Jewelers' League in the making of assessments. In future it is proposed to assess on the first of every month for all deaths authentically reported the previous month. This will more evenly distribute

the payments by members, and avoid the burden of any heavy assessment. It is such changes as this that prove the League to be a progressive organization, constantly seeking the welfare of its members.

LITTLE ROCK, Ark., Jan. 2, 1895.

The Jewelers' Circular Pub. Co.:

DEAR SIRS—Have noticed in the columns of THE CIRCULAR at different times articles in reference to the stamping of silver manufactures.

If you have selected no one for Arkansas to represent you in the matter, would be pleased to take it up as our Legislature meets here this month and that bill is too good a one to allow even a single State to slip by. Respectfully, SPOTT & JEFFERSON.

IN accordance with the above letter THE CIRCULAR gladly forwarded to Spott & Jefferson a copy of the silver stamping bill referred to drafted by this journal. As there is not one sound argument against the passage of such a measure, it is reasonable to infer, the bill having been or being about to be introduced in the principal States, that we will shortly have throughout the Union practically universal legislation on the subject of stamping silver wares. As communicated to THE CIRCULAR by Mermod & Jaccard Jewelry Co., St. Louis, Mo., the latest development in this connection is the promised introduction of the bill in the Missouri State Legislature.

**To Protect** "STORE heavily robbed; we will now join your association." This is a copy of a telegram, dated Jan. 4, received by the Jewelers' Security Alliance from George W. Hickok & Nixon, of El Paso, Tex. There is an old aphorism reflective of some errors of human conduct which expresses the uselessness of locking the stable after the horse has been stolen. If Messrs. Hickok & Nixon had, before their misfortune, displayed a certificate of the Alliance they would now, doubtless, still be in possession of their valuables; for the "enterprising burglar" has learned that to rob the store of a member of the Jewelers' Security Alliance is a very dangerous undertaking. Membership in this organization is one of the most profitable investments a jeweler can make, considering its trifling cost and the protection it insures.

### The Silver Stamping Bill to be Introduced in the Missouri Legislature.

ST. LOUIS, Jan. 3, 1895.

The Jewelers' Circular Publishing Co.:

GENTLEMEN:—We have placed the Sterling Silver bill in the hands of Senator R. D. Landcaster of our State, who promises us that it will be presented at the earliest possible moment for action by the Legislature and that he will use all earnest and legitimate measures to have it passed.

As you have taken so much interest in this matter we thought we would give you this early advice of what has thus far taken place in connection with it.

Yours very truly,

MERMOD & JACCARD JEWELRY CO.

### The Sudden Death of John O. Holden.

BOSTON, Mass., Jan. 5.—John O. Holden, Quincy, Mass., died suddenly of heart disease, Thursday evening, while attending a meeting of the Quincy City Council, of which he was a valued member. It was the closing session of the outgoing administration, and an entertainment was about to follow the regular business of the council. Guests were present, among them being Mrs. Holden, but so sudden was the stroke that he was unable to speak a last word by the time she reached his side.

Mr. Holden had been for more than 35 years a prominent jeweler in Quincy, having succeeded his father in the business, which the latter established in 1840. He was 61 years of age. In this city much sorrow is expressed among the jobbers, with whom he had sustained the pleasantest of business relations for so many years and by whom he was held in high regard.

A special meeting of the council was held Friday and resolutions of respect were adopted by that body. The funeral of Mr. Holden took place to-day, services being held at the First church.

### Proceedings of the Jewelers' League.

The regular monthly meeting of the executive committee of the Jewelers' League was held Jan. 4th. There were present Vice-Presidents Bowden and Greason, Chairman Bardel, and Messrs. Van Deventer, Jeannot, Fessenden and Stevens, Jr., secretary.

The minutes of the previous meeting were read and approved. There was one request for change of beneficiary received and granted and the following members were admitted:

Section A, Edward B. Gerlach, Columbus, O., recommended by W. G. Harrington and A. H. Bonnet.

Section B, W. J. Miller, Baltimore, Md., recommended by H. A. Leonard and J. C. Justis.

Section B, Henry G. Springer, New Orleans, La., recommended by William B. Young.

Section B, H. A. Siegfried, Allentown, Pa., recommended by E. Keller, C. H. Higbee, L. Fisher and C. F. Duffy.

The beneficiaries of the following members were paid \$5,000 each, making a total of \$65,000: Eugene J. Cuendet; Eugene A. Crawford; J. F. E. Rosset; C. C. Lamos; W. W. Scott; Alexander Dominick; Wm. A. Henry; Henry J. Conway; C. J. Theuerner; John Crocker; Chas. C. Camerden; Philip Maucher and Joseph Jones.

### The United States Watch Factory to be put up for Sale.

BOSTON, Mass., Jan. 8.—The late Emil C. Hammer, who was treasurer of the United States Watch Co., Waltham, left no will. Under the Massachusetts law the factory will be put up for sale.

### New York Notes.

Frank Jeanne, of Wm. S. Hedges & Co., sailed for Europe Saturday, on the *Etruria*.

Singer & Robin, 280 E. Houston St., have given a chattel mortgage on jewelry fixtures to M. Reinach for \$150.

The judgment for \$758.80 entered Oct. 30th by the Gorham Mfg. Co. against Robert A. Osborn, has been satisfied.

Owing to a fire which recently broke out at Broadway and Park Ave., Brooklyn, the stock of David Michel, jeweler, suffered considerable damage by water.

Arnold & Steere, manufacturing jewelers, Providence, R. I., have opened a New York office in the Stevens building, 3 Maiden Lane. H. E. Kingman is in charge.

Judge Van Wyck, of the City Court, Thursday, granted a motion to vacate one of the attachments against the East Side Jewelry Exchange, issued Dec. 26th.

Berman Bonner, 525 Sixth Ave., has given a chattel mortgage on jewelry store fixtures to D. Bonner for \$600. He also gave a bill of sale of fixtures to A. Kohn & Co., for the same amount.

Sim. Englander, formerly of Henry Dreyfus & Co., now represents the New York branch of S. Konijn & Co., diamond cutters and importers, Amsterdam, Holland, and 68 Nassau St., New York.

The annual meeting of the stockholders of the Star Watch Co. was held Tuesday evening, Jan. 8th, at the office of Joseph Corbit, 212 Ninth Ave. Officers and directors for the ensuing year were elected.

The annual meeting of the stockholders of the F. Kroeber Clock Co., for the election of trustees for the coming year is announced to take place on the 15th of January, at the office of the company, 360 Broadway.

Herzog, Goldsmith & Frank, importers of diamonds and manufacturers of jewelry, 52 Maiden Lane, have leased the entire 4th floor of the Diamond Exchange, 14 Maiden Lane into which they will remove about Feb. 1.

Oppenheimer Bros. & Veith Thursday entered judgments for \$2,010.14, \$1,079.95 and \$1,330.07 against Sigmund Gutman and Louis Lichtenstein composing the firm of S. Gutman & Co., 51 Maiden Lane, whose failure was reported last week.

Tiffany & Co. have offered to place an electric clock in the 22d Regiment Armory on Columbus Ave. The clock will be on a level with the elevated trains. It will be illuminated at night, and will be visible from within as well as without the armory.

M. Wolfe denies the rumor that he has left the employ of Fred. Kaufman, 41 Maiden Lane, and states that he will continue to represent this firm on the road as heretofore. On his next trip he will carry an entirely new and complete line of the latest goods.

T. C. Sennet, jeweler, 278 Manhattan Ave., Brooklyn, was stricken with paralysis recently while riding in a Greenpoint horse car. The conductor who happened to know him stopped the car in front of his place and assisted him to the store. Word was sent to relatives who took him under their care.

Early Wednesday morning a thief or thieves smashed the side window of the jewelry store of Frederick Kanter, 12th St. and Broadway, and stole goods valued between \$150 and \$200. When Mr. Kanter reached his store at 6.30 o'clock A. M., he discovered that the glass had been smashed and three watches, a dozen souvenir spoons and a quantity of novelties had disappeared. He reported the robbery to the police, but no arrests have yet been made nor have the goods been located.

J. H. Johnston & Co., 15th St. and Union Square, were recently amused at receiving a "roasting" from a customer in Jasper, Ala., for sending sterling in place of solid silver. The customer, who by the way was a woman, apparently thought she had been cheated, and proceeded to berate the firm for not sending solid silver as they had advertised. She said she could purchase "sterling" silver in her own locality very much cheaper.

A window robbery occurred shortly after 5 o'clock, Friday morning, when the plate glass window of the store of Simpson, Hall, Miller & Co., 36 E. 14th St., was broken and about \$200 worth of goods stolen. When the engineer arrived to work at 5 o'clock everything was quiet and shortly afterward the robbery was discovered. The booty consisted of three watches and a quantity of silver novelties. At the store of Simpson, Hall, Miller & Co., it is thought that the police seem to take little interest in the robbery.

Max J. Lasar, on Jan. 1st, became a special partner in the firm of Adolph J. Grinberg & Co., diamond importers and manufacturers of jewelry, at 30 Maiden Lane. Mr. Lasar, who is a diamond dealer, at 24 Maiden Lane, takes the place of Mrs. Grinberg, the former special partner, who retired Dec. 31st. He contributes \$15,000. Both the business of A. J. Grinberg & Co., and of Mr. Lasar will be continued as heretofore without change.

Frank L. Palmer, an employe of Postal Station A, was held in \$2,500 bail for the Grand Jury by Commissioner Shields, Saturday, on the charge of robbing the mails. The arrest was the outcome of a complaint from Lynn & Co., who do a catalogue business in jewelry at 48 Bond St., that large numbers of letters containing remittances were intercepted. When the inspectors arrested Palmer, in his possession were discovered fifty unopened letters addressed to Lynn & Co. A pile of opened letters, all addressed to the same firm, was also found. Palmer confessed his guilt.

A meeting of the creditors of Bertha Ehrlich, whose assignment to Isaac Hirsch

was published in THE CIRCULAR last week, was held at the office of the assignee's attorney, Louis S. Phillips, 35 Broadway, Friday afternoon. The 17 creditors present represented over one half the merchandise indebtedness. A statement of the assets and liabilities as already published in THE CIRCULAR, was made by the attorney, and the following settlement was offered: 25 per cent. in four notes satisfactorily endorsed, due in three, six, nine and twelve months. A paper embodying this proposition was signed by nearly all the creditors present.

Wm. E. Bidwell, who on Dec. 30th was found dead in bed at his home, 387 Jefferson Ave., Brooklyn, is believed to have poisoned himself. An autopsy disclosed carbolic acid in his stomach; whether the acid was taken with suicidal intent or accidentally could not be determined. Mr. Bidwell was a member of the Jas. H. Hart corporation of Brooklyn, who went into liquidation last March. He was born in Burnside, Connecticut, in 1846 and passed his early youth in this town. He served in the Sixteenth Connecticut Regiment, and after the war went into the jewelry business near Exchange corner, Hartford, removing in a year or two to Brooklyn. He married twice. His second wife and two sons by his first wife survive him.

Charles L. Camerik, 19 years old, a clerk in the employ of the Spencer Optical Mfg. Co., was arrested Thursday charged with stealing from his employers. During the past few weeks his employers missed valuable opera glasses and gold framed spectacles, and manager John S. Spencer reported the matter to the police. A detective after watching Camerik for a few days placed him under arrest. At first Camerik strenuously denied having taken the goods but finally broke down and confessed. Camerik said he had given the stolen property to Henry Meyer, who pawned it for him. Both Camerik and Meyer were arraigned in the Tombs Court Friday morning and were held for trial. Part of the stolen property, which in all amounted to about \$150, has been recovered.

Deputy Sheriff Heimberger Friday took charge of the store of Benton Carr Carlton, jeweler, at 417 Sixth Ave., on a claim for \$1,029 in favor of David S. Decker on a note. Mr. Carlton disappeared New Year's eve, as did some of his stock. He said he was going to Boston. Carlton's liabilities in this city are said to be about \$4,500. Among his creditors are A. Peabody, Max Freund & Co. and C. E. Sherwood. From the last named Carlton purchased a bill of goods only a few days before his disappearance. Mrs. Carlton, who with her child lives over the store, does not know where her husband has gone, and is anxiously looking for him. Carlton is about 50 years old, and came from Atlanta, Ga., where he did business as a jeweler and pawnbroker. Before that he is said to have been in business in Portland, Ore.



**L. TANNENBAUM & Co.,**

IMPORTERS AND CUTTERS OF

**Diamonds and Precious Stones,**

Cor. Maiden Lane & Nassau St.

**NEW YORK.**

25 Hatton Garden, London.

TELEPHONE, LONG DISTANCE 1959 CORTLANDT.

## Special Announcement.

Mr. L. Tannenbaum begs to notify his customers and the trade in general, that he has largely extended his facilities for cutting and polishing. Hereafter he will cut and polish not only RUBIES and SAPPHIRES, which has been done for the past 15 years with increasing and gratifying success, but

# DIAMONDS

and all other stones which undergo this process.

Modern machinery of the best and most approved pattern, and workmen of the highest class will enable Mr. Tannenbaum to offer, direct from the cutter's hands, that excellent workmanship demanded by American buyers, at

## PRICES THAT DEFY COMPETITION.

Nor will buyers of Diamonds be the only people benefited. Mr. Tannenbaum imported a five years' supply of rough Rubies and Sapphires DUTY FREE under the old tariff. These goods are now being cut and polished and it is very evident that in these particular stones he can make UNAPPROACHABLE PRICES.

New York as the future Diamond Market is not a phantasy. American cutters will be shown an assortment of rough, at prices which will perhaps cause them to believe that this has already been brought about. All arrangements have been made by the firm for enormous shipments of DIAMONDS, EMERALDS, PEARLS, SPINELS, CATSEYES, MELLEES and all kinds of Precious Stones, although to-day the assortment offered by L. Tannenbaum & Co. ranks second to none in this country.

 HIGHEST PRICE PAID for all AMERICAN PEARLS and OTHER PRECIOUS STONES.



# ALWAYS



## DON'T LOOK

YOU CAN FIND OUR GOODS IN ANY FIRST-CLASS

EVERYTHING IN

**Lorgnettes**  
 IN A VARIETY OF STYLES, AT PRICES  
 THAT ARE RIGHT.

**Bra**  
 FOR THE M  
 AN

And Our Lines of **NECKS AND GE**

# Twenty-Five Years Tell the Story. On Top Then. On Top Now.

EVERY CHAIN BEARS ONE OF THE FOLLOWING TAGS :





# ON TOP.



## IN VANE.

JOBBER'S STOCK. IF YOU CANNOT, WRITE US.

THE CHAIN LINE. 

lets

CHILDREN  
ES.

### Victorias

HANDSOME STYLES FOR THE HOLIDAYS.  
YOU NEVER SAW THE LIKE,

VEST CHAINS ARE UNSURPASSED. 

# W. & S. BLAGKINTON.

1d Reliable  
W. & S. B. ★  
Globe Filled,  
Seamless Wire,  
Cold Soldered  
Joints,  
Warranted  
20 years.

WARRANTED  
○ 14 Kt. Plate.  
○ 10 Kt. Gold Solder  
Seamless Wire ★

W. & S. B. ★  
14 Plate, 14 Karat,  
Warranted to  
Assay 1-4 Gold.

W. W. Holmes has entered a judgment for \$134.50 against Gerson Goolenberg.

A judgment for \$179.98 has been entered against Hugo Markers by F. Kaffeman.

Henry Thomas, treasurer of the Jewelers' Mercantile Agency, was last night presented with a magnificent Past Chief Ranger's badge by Court W. S. Hancock 7354 A. O. F. of A., in which he held the position of chief ranger for three successive terms.

On consent of attorneys, Judge Fitzsimons, of the City Court, Monday discontinued the action in replevin brought by the American Watch Case Co. against Sol Lindenborn. The action arose through the attempt of the plaintiff to replevin goods sold to Nathan Rogers, who gave a bill of sale to Lindenborn.

Laubheim Bros. is the name of a new firm of diamond importers and manufacturing jewelers at 79 Nassau St., formed yesterday. The partners consist of Max Laubheim, who formerly conducted the business at that address, and Samuel and Leopold Laubheim, both of whom were with Adolph Goldsmith & Son, until Jan. 1st. Leopold Laubheim represents the new firm on the road.

Oppenheimer Bros. & Veith emphatically deny the truth of the reports published in several morning newspapers, which stated that this firm were creditors of Lichtenstein Bros., of 23d St. It is thought the mistake originated from the fact that Oppenheimer Bros. & Veith entered judgments against H. Lichtenstein and S. H. Gutman, composing the firm of S. H. Gutman & Co., who failed about the same time as did Lichtenstein Bros.

Gerson Gootenberg, a jeweler of 448 Grand St., who failed recently, was held in \$1,000 for trial by Justice Burke in the Essex Market Police Court, Wednesday, on a charge of secreting property with intent to defraud creditors. The complainants were B. H. Davis & Co., diamond dealers, at 68 Nassau St., from whom Gootenberg obtained \$2,617.30 worth of jewelry and diamonds on credit. About Dec. 15 B. H. Davis & Co. became suspicious, and on advice of their attorney, Ed. Kaufman, 15 Chambers St., had Gootenberg's place watched by a detective. When Gootenberg was closed out, Dec. 26, on a judgment for \$960 to his brother-in-law, the diamond jewelry, previously shown in his window, disappeared and imitation stones and cheap goods took its place. B. H. Davis & Co. then caused his arrest. The sheriff's sale, Wednesday, did not realize sufficient to pay the judgment of his brother-in-law. B. H. Davis & Co. will also have Gootenberg up in supplementary proceedings.

Bloom & Phillips is the name of a new wholesale house of Cincinnati, O., formed by J. S. Bloom and Jos. Phillips. Their office is at 228 Fourth St. The principal lines handled by this firm are silverware, cut glass, fancy goods and bric-à-brac.

### Last Week's Arrivals.

The following out-of-town dealers were registered in New York during the past week: J. Mehmert, Cincinnati, Ohio, St. Stephens H.; H. L. Joseph, Chicago, Ill., Grand Union H.; J. Floersheim, Chicago, Ill., Imperial H.; H. M. Yeager, Philadelphia, Pa., Oriental H.; L. S. Weil, Pittsburgh, Pa., Astor H.; D. Auer, Albany, N. Y., Astor H.; F. W. Kirk, Baltimore, Md., St. Denis H.; A. L. Bearse, Boston, Mass., Murray Hill H.; C. H. Hurlburt, Philadelphia, Pa., Holland H.; A. Zug-smith, Philadelphia, Pa., Albert H.; W. Shafer, Cobleskill, N. Y., Morton H.; A. C. Allen, Chicago, Ill., Grand Union H.; L. Emery, Jr., Bradford, Pa., Astor H.

### Albert B. Kapp, It Was Decided, is Not a Poor Debtor.

PROVIDENCE, R. I., Jan. 5.—The members of the Manufacturing Jewelers' Board of Trade are very well pleased to-night and Albert B. Kapp, of New York, correspondingly depressed, at the result of the hearing to-day on the petition of Kapp for the poor debtor's oath. It took about 15 hours to convince the court that Kapp was not a poor debtor.

A preliminary hearing was held a week ago last Wednesday and was continued until to-day. At 10 o'clock a party numbering about 30 assembled at the County Jail in Cranston. Among the number were A. B. Kapp, of New York, Bernhardt Selig, of Philadelphia, A. Kahn, of New York, the attorneys and members and officers of the Board, and THE CIRCULAR correspondent. The hearing was long drawn out and devoted principally to arguments and objections. J. B. Johnson, reporter for R. G. Dun's agency of New York and Samuel Anderson, reporter in New York of the Manufacturing Jewelers' Board of Trade both testified as to Kapp making certain statements to them concerning his business standing which afterwards were proved to be false and unreliable. These, with Benjamin Lederer and secretary Marcus W. Morton, constituted all the witnesses for the complainants.

Kapp was put on cross-examination but nothing new was brought out except that the stock which he transferred to Selig was never inventoried when it was transferred, was not opened while out of his possession, was not inventoried when returned to him at the Empire Jewelry Co. and was substantially the same as when transferred to Selig. He admitted that the Empire Jewelry Co., when it came into existence, occupied the same rooms as the A. B. Kapp Mfg. Co.

The refusing of the oath leaves Kapp a debtor, who is out on bail, which is \$10,000. He will remain on bail until after the creditors obtain judgments on their writs, when he will either have to satisfy the judgments or be remanded to jail on executions, where he will remain as long as the creditors pay \$3 per week for his board, until he

settles the claim against him. The manufacturers are right up in arms concerning this matter and state that they have been imposed upon by dishonest dealers as long as they propose to be, and will spend every dollar of their claim to hold Kapp closely to the rack.

### S. T. J. Byam Commits Suicide Without Apparent Reason.

S. T. J. Byam, the local manager for the Pratt & Whitney Tool Works, 138 Liberty St., New York, who committed suicide in his office early Monday morning, by firing two bullets from a 32 calibre safety-arm bull-dog revolver into his head, was well-known to many among the watch factories, having been prominently connected with several important watch companies. Mr. Byam was still alive when an ambulance arrived, but died five minutes after reaching the Hudson St. hospital. No reason for his suicide has yet been learned.

Mr. Byam was 48 years old and lived at 19 Tisca St., Newark. He was married, but had no children. He had been manager of the salesrooms of the Pratt & Whitney Tool Works, which is situated on the ground floor of the Electrical Exchange building, 138 Liberty St., since last March. He was a well-known figure among watch factory men. At one time he was with the American Waltham Watch Co. and after leaving them went with the Waterbury Watch Co. where he took charge of their train department. When the New Haven (now Trenton,) Watch Co. organized about 1884 Mr. Byam became superintendent of their factory, a position he retained until about four years ago. Mr. Byam's brother now has charge of one of the principal departments in the American Waltham Watch Co., while another brother is with the Waterbury Watch Co.

### Hickok & Nixon's Store Reported to Have Been Looted.

DALLAS, Tex., Jan. 3.—A special to the press of this city from El Paso says: More than \$10,000 worth of diamonds and other jewelry was taken from the store of Hickok & Nixon early yesterday morning. The front door, which is always locked, was opened by boring the lock off, and the big safe was treated in the same way. Not a valuable stone or watch was left in the house, but not a cheap watch was disturbed.

The work was evidently that of an expert, which all the more mystifies the officers. Three other stores were also entered, but it is thought by common burglars.

The sale conducted by A. J. Comrie, for the Upson Jewelry Co., Waterbury, Conn., ends Jan. 9th. The firm will move to temporary quarters until April 1st, when they will move in their new store. Mr. Comrie, on Jan. 10th, commences a sale for R. S. McWatty & Co., 27 Fifth Ave., Pittsburgh, Pa., who are going out of business.

# DIAMOND CUTTING INDUSTRY IN AMERICA.

## PART III.

THE diamond cutting factory of Henry Fera, at 66 Fulton St., New York, was started up only a few days ago, but to an outside observer it would appear as if it had been in operation for years, as everything goes along in an orderly manner

This has been shown to give a more uniform speed to the polishing wheel and a longer life to the belt. It is not always found, however, that the floor space will permit of this luxury. The machinery is driven by a "C. & C." electric motor which runs very



VIEW OF THE DIAMOND CUTTING FACTORY OF HENRY FERA.

under the management of Mr. Fera and his son. It must be remembered that the former is not an amateur in this business and therefore does not try to perform impossible tasks.

Mr. Fera has taken great care in the selection of his plant and workmen. He has abandoned all of his old machinery and his new place is equipped with Arthur's mills of the best and stiffest pattern. They are set in two solid lines, one row being in front and the other at the back of the building and facing large single light windows in each case.

The setters' benches are metal covered and extend the full width of the factory both back and front and are provided with tool drawers. The mills themselves are fitted up with drawers and locks, protection plates, pocket shelves and foot rails and racks for spindle plates. The driving shafts are of heavy steel and well protected with iron railing so that a workman cannot hurt himself unless he goes over the rail and among the belts, where he has no business to go.

The Arthur Co., when planning and equipping this factory, put the driving shaft a considerable distance from the mills, thus giving greater length to all driving belts.

quietly and gives no trouble and can be run holidays or nights if the pressure of orders requires.

D. Arthur, of the Arthur Co., has invented a method of driving a double or triple row of diamond polishing mills entirely independent of the small belts and upper arms and cross bars. This would enable a factory owner to utilize his floor space and natural light to better advantage and do away with that cumbersome and more or less dangerous floor shaft. Mr. Arthur states that if America decides to hold the diamond cutting industry here, he can reduce the running expenses for the factory owner and at the same time enable the operative to get on more comfortably with his work.

*(Series to be continued.)*

In the matter of assaying and refining J. Rathbone, Providence, R. I., presents elsewhere in this issue an announcement which is terse and to the point. The capacity of the establishment is 1,500 pounds of state clips per week. Returns are promptly made and Mr. Rathbone has on file hundreds of letters complimenting him on the satisfactory nature and promptness of the returns as made by him.

## Trade Gossip.

Blackinton's chains represent style, finish, wearing qualities and selling qualities. Don't forget that the "Old Reliable" is the W. & S. B.

Things are rushing at the shop of Irons & Russell, Providence, R. I. The firm's line of emblems was never better and the trade is endorsing this fact.

Waite, Thresher Co.'s popular and salable lines move along as briskly as ever. "Waite, Thresher Co.'s goods sell" is what every jobber should bear in mind.

George T. Greene & Co., Providence, R. I., whose announcement appears on another page, show an exceedingly artistic and taking line of Czarina buckle collarettes, enameled shields, shepherd's crooks and stick pins. The finish is Roman and engraved silver and the white metal used in the latter is of the firm's own production, of excellent body, in finish exactly like silver, and in wearing qualities perhaps superior. It may be cut or engraved or worn off but the pure silver whiteness is part and parcel of the metal itself and is always there. The enameling on the goods is all in delicate art shades and greatly enhances their beauty. There is also a most complete line of belt buckles shown and new goods are produced constantly. Prices will, without doubt, surprise many dealers who have not already seen the lines. W. S. Greene is now on the road and reports an excellent trade.

A roadster weighing 19 pounds and guaranteed to carry any rider over ordinary roads is the marvelous result of the evolution of the bicycle. A few years ago, when safeties weighed from 48 to 60 pounds, the Keating Wheel Co., Holyoke, Mass., placed on the market a roadster weighing 32 pounds. It was predicted that this wheel would go down. While it was admitted by all to be a handsome and fleet wheel, it was claimed there could not be sufficient strength to sustain the weight of the average rider. In fact, it was the common belief that weight as applied to bicycles was strength. Those 32 pound wheels, which instantly became prime favorites and which are in constant use to-day, served not only to inaugurate the crusade against heavy weights, but at one great bound brought into prominence the Keating Wheel Co., who, knowing that they had reached the acme of perfection in form, and with an abiding faith in the material used and their method of treating it, steadily reduced the weight while not in the least diminishing the strength of their machine; and their crowning triumph is shown in the superb line of eight models as described in their '95 catalogue and which are fully guaranteed.

M. C. Fish, of the Kent, Stanley Co., arrived home last week. Mr. Fish is as good company as ever, sells lots of goods and is sure of a welcome everywhere.

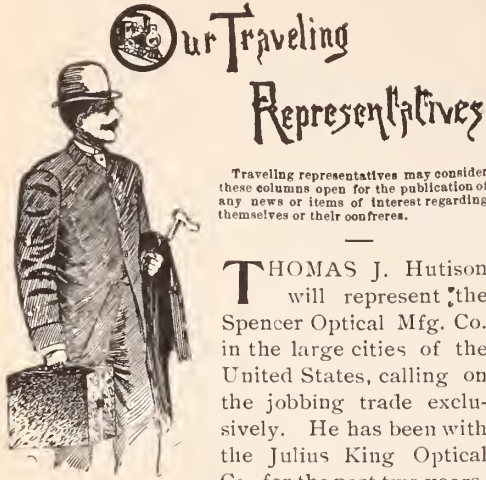

Traveling representatives may consider these columns open for the publication of any news or items of interest regarding themselves or their confreres.

**T**HOMAS J. Hutison will represent the Spencer Optical Mfg. Co. in the large cities of the United States, calling on the jobbing trade exclusively. He has been with the Julius King Optical Co. for the past two years,

but returns to the Spencers to solicit especially the business done through their European offices and the large trade in this country.

H. B. Bliss, of Gorham Mfg. Co., has just left on a trip through Ohio and Michigan.

W. C. Barry, formerly a retail jeweler of Danbury, Conn., is now representing Larter, Elcox & Co. on the road.

Ed. J. Mayer is again with the Julius King Optical Co., 15 Maiden Lane, and will represent this company in the southern States.

J. Zineman, formerly with the Seth Thomas Clock Co. and Simpson, Hall Miller & Co., will hereafter represent Marx, Veit & Co., 51 Maiden Lane, in the south.

Louis Berger, representing H. B. Peters & Co., 177 Broadway, New York, is out through western New York in the interests of his firm and reports trade as improving.

B. M. Henschel, formerly with Wm. Morris & Co., Philadelphia, Pa., now represents Marx, Veit & Co., 51 Maiden Lane, and will cover the Eastern and Middle States for this firm.

Jos. H. Sandman, former selling agent for the Trenton Watch Co., Trenton, N. J., has severed his connection with this company who will soon be represented on the road by Geo. B. Evans. All communications to the company should be addressed, for the present, to headquarters at Trenton, N. J.

A. Marshuetz, the popular traveling salesman representing the Spencer Optical Mfg. Co., will shortly begin his annual tour to greet his many friends and customers and solicit their patronage. He starts out full of hope, and expects through his usual energy to retain the support and confidence of his patrons, to whom he is so highly indebted for past favors.

Travelers in Pittsburgh, Pa., last week were: E. A. Reed, Reed & Barton; O. C. Lane, Reed & Barton; E. L. Mumford, Waite, Thresher Co.; Gus W. Strandberg, E. L. Spencer & Co.; Harry J. Hilderbrand for H. C. Lindol; S. O. Bigney, S. O. Bigney & Co.; Mr. Melcher, Bennett, Melcher &

Co.; Ed. Rogers, Parks Bros. & Rogers; Harry Scofield, Lincoln, Bacon & Co.; Harry Kenmon, H. D. Merritt & Co.; Mr. Platt, Foster & Bailey; and G. A. Dean, Enos Richardson & Co.

The Twin Cities jobbing houses will make no change in their force of traveling salesmen the coming year. The following is a complete list: Reed & de Mars Jewelry Mfg. Co., by W. H. Creveling; Spaulding Bros., by E. E. Spaulding; H. E. Murdock, by Louis Gans; Sicho & Beard, by Mr. Beard; I. B. Miller Jewelry Co., by I. B. Miller; S. H. Clausin & Co., by Clarence Schleiker, and J. M. Sinclair. The Minneapolis Jewelry Mfg. Co., as usual, will not have any traveling representatives.

Among the travelers in Cincinnati last week registered at the Gibson House were: W. F. Briggs, H. P. Kent, F. C. Brigham, J. J. Metcalf, S. O. Bigney, P. P. Bliss, Geo. Marsh, of Attleboro; W. H. Scofield, H. M. Tallman, C. W. Bailey, W. S. Griffith, A. A. Greene, of Providence; E. I. Rogers, M. Mitcher, G. C. Hudson, Ernest Block, H. A. Scofield, W. P. Stowe, F. T. Chapman, Baron Kennion, of New York, Geo. Merrill, G. L. Paine, of Boston; John W. Major, of Brooklyn; W. E. Cobb, of Chicago; and Fred. and Thos. W. Mockridge, of Newark. They are all en route west in high spirits.

Traveling men visiting the Indianapolis trade last week included: F. A. Fairbrother, Jr., B. K. Smith & Co.; J. M. Phillips, Hamilton & Hamilton, Jr.; Fred. Heffron, Riley, French & Heffron; H. E. Cobb, Daggett & Clap; Harry B. Kennion, H. D. Merritt & Co.; E. L. Mumford, Waite, Thresher Co.; G. Rodenberg, S. & B. Lederer; J. H. Killion, Donley & Co.; Mr. Melcher, Bennett, Melcher & Co.; Ernest Block, W. & S. Blackinton; representatives of R. L. Griffith & Son; W. O. Hutchins & Co.; W. H. Wilmarth & Co., C. H. Cook & Co.; Mason Jewelry Co.; G. C. Hudson, H. F. Barrows & Co.

### Philadelphia.

John C. Kelley has been ill for some weeks.

Articles valued at \$25 were stolen from the store of S. Barrenkopf, 244 South St., on Tuesday night last by three boys who escaped.

A. R. Justine & Co. obtained a verdict of \$1,250 against the city, last week, for damages sustained by the widening of Chestnut St., between 7th and 8th Sts.

Edward T. Taylor was an unsuccessful candidate for reading clerk of the State House of Representatives. Mr. Taylor, whose store is at 1020 Chestnut St., is a native of Delaware County.

Judgments were entered against J. G. Rosengarten & Co., 716 Arch St., and against Gustav Yeager, Front and Race Sts., during the week. The amount involved in the latter case was \$1,000.

In Quarter Sessions Court No. 1, on the

31st ult., John Wood, 2624 Frankford Road, the jeweler who was charged with assault and battery on 16-year-old Lizzie Fitzpatrick, was found guilty and sentenced by Judge Jenkins to six months in the County prison.

Out-of-town buyers here the past week included: A. Thoss, Boyersford, Pa.; Joseph Ladunus, Chester, Pa.; Howard Fitzsimmons, West Chester, Pa.; Charles Funk, of Stone & Funk, Lebanon, Pa.; Geo. Press, Oxford, Pa.; and John Dewar, Bryn Mawr, Pa.

The firm of H. Muhr's Sons has been dissolved by mutual consent, and Jacob Muhr and Philip Muhr have formed a new co partnership for the manufacture of watch cases and jewelry at 19th and Hamilton Sts. Jacob Muhr, who was the old firm's buyer of precious stones, will have charge of the general business of the new firm, and Philip Muhr will have charge of the manufacturing department. The arrangements for the new enterprise will not be ready, however, for probably three months. Meanwhile the liquidation process will be observed at 7th St. and Chestnut St., and it is believed that by March the stock will be sold. It is rumored that then Simon Muhr will carry on the business, in conjunction with one of the principal employes of the firm. It is also stated that Harry Schimpf will associate himself with Jacob Muhr. In the meantime there will be no change in the working staff of the establishment.

### Judgments Executed Against C. R. Smith & Son.

PHILADELPHIA, Pa., Jan. 5.—Judgments amounting to \$24,400.53 were on Thursday executed against the firm of C. R. Smith & Son, composed of Charles E. Smith and J. Henry Bailey, No. 1018 Chestnut St. The judgments were in favor of Annie K. Smith. The store was immediately closed, and the assets will be disposed of in the ordinary legal manner.

It is not known to what extent creditors' claims will go, but it is not believed that the local obligations are heavy. The firm was in difficulties in May, 1893, when their liabilities amounted to \$63,000. They offered a compromise at that time at 50 per cent. cash, 20 per cent. payable Jan. 1, 1894, and 10 per cent. payable June 1, 1895. It was stated that this trouble was due to the extensive speculations of a trusted clerk, who was subsequently arrested and convicted.

The present collapse is explained by the firm as the direct result of the hard times.

The Waterbury Watch Co.'s factory began last Wednesday, Jan. 2d, to run 10 hours per day.

Judge Reeder, of Allentown, Pa., granted an injunction on the sheriff of Northampton county, restraining him from selling the goods in the jewelry store of James K. Rauch, Bethlehem. The application was made by S. F. Myers & Co., New York, who allege that the judgment confessed by Rauch to his wife for \$10,000, is fraudulent.

**The Latest Patents.**

ISSUE OF DEC. 25, 1894.

**531,135. WATCHMAKER'S LENGTH-GAGE.** HENRY J. COGSWELL, Hartford, Conn.—Filed Oct. 1, 1894. Serial No. 524,578. (No model.)

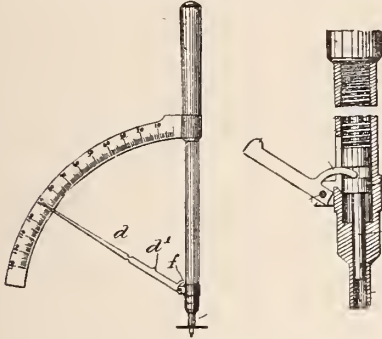

In combination in a length gage a handle, the tubular shank terminating in a nipple, an index arm pivoted to the shank with a branch extending within the latter and in contact with a plunger, a plunger located within the shank and having a shoulder co-operating with the shoulder within the shank whereby the outer end of the plunger is held in exact alignment with the outer end of the nipple, a spring actuated piston arranged within the plunger and pressing upon the branch, and a graduated arm adapted to be traversed by the end of the index arm.

**531,155. TOOL FOR ORNAMENTING WATCHCASES, &c.** CHARLES WILHELM, New York, and FREDERIC ECAUBERT, Brooklyn, N. Y., assignor to said Ecaubert.—Filed May 23, 1894. Serial No. 512,156. (No model.)

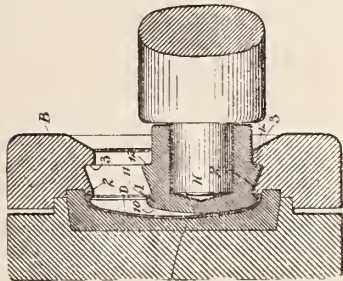

The combination in tools for making watchcase lids and similar articles, of a die corresponding internally to the exterior of the article to be produced, a die having a central opening corresponding or nearly so to the inner edge of the lid or similar article, a roller corresponding at its periphery to the interior of the article near the edges thereof, and shoulders in rigid connection with the die and at a distance from such article and by which the roll is supported while finishing the interior of such article.

**531,180. WATCH-BOW FASTENER.** ERICK

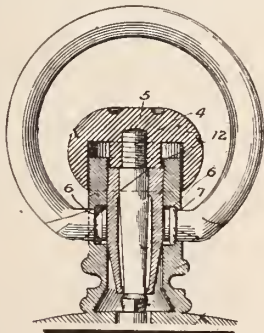

J. SWEDLUND, Atwater, Minn.—Filed Dec. 5, 1896. Serial No. 592,836. (No model.)

The combination, with the watch head or pendant provided with peripheral openings forming interior sockets 6 having smaller openings leading therefrom, of the watch-bow having grooved ends inserted into said sockets, and a split ring 10 clamped in the groove of

each end of said ring by the walls of said socket and forming an obstruction to the withdrawal of the end of the bow.

**DESIGN 23,884. BADGE.** JOHN F. KELLER,

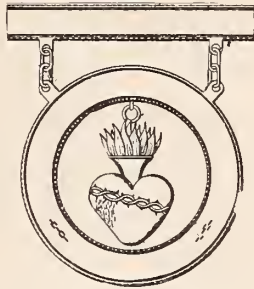

St. Louis, Mo.—Filed Oct. 17, 1894. Serial No. 526,226. Term of patent 7 years.

**DESIGN 23,890. PITCHER.** CHARLES C. WEINTGE, Providence, R. I., assignor to the

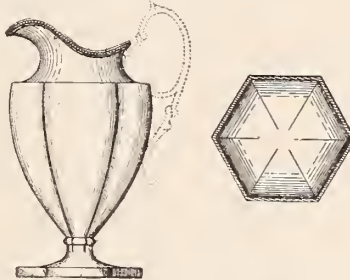

Howard Sterling Co., same place.—Filed Oct. 29, 1894. Serial No. 527,361. Term of patent 7 years.

**DESIGN 23,901. COMMUNION SERVICE TRAY.** EDWIN J. HOWE, Newark, N. J.,

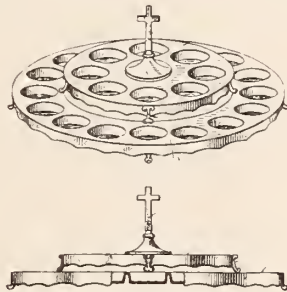

assignor of one half to George R. Howe same, place.—Filed Nov. 17, 1894. Serial No. 529,188. Term of patent 14 years.

ISSUE OF JAN. 1, 1895.

**531,789. MACHINE FOR SPINNING WATCH CASES, LOCKETS, &c.** FREDERIC ECAUBERT, Brooklyn, N. Y.—Filed Aug. 11, 1894. Serial No. 520,027 (No model.)

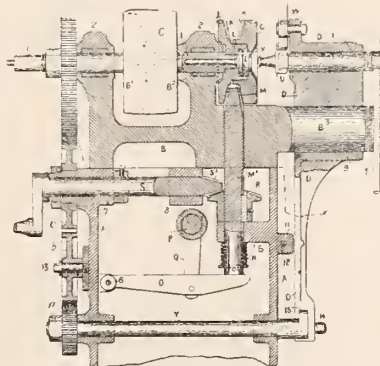

The combination with a die having an internal configuration that is not circular and corresponds to the article to be produced, of means for supporting and rotating such die, a roll for acting upon the interior of the article within such die, a support for the roll, and automatic mechanism for causing the said roll to follow the contour of the internal die.

**531,979. OPERA-GLASS.** NATHAN A. SHIGON, New York, N. Y., assignor to Henry Lorsch, same place.—Filed June 4, 1894. Serial No. 513,351. (No model.)

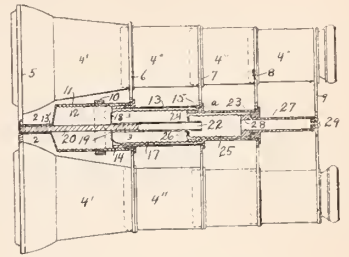

A glass having two sight tubes, each consisting of a main body and several tube sections, movable one within another and in the same direction, a rotatable screw handle, and means consisting of as many screws and sleeves or parts moved thereby as there are tube sections for simultaneously moving all the said tube sections.

**531,994. LENS.** LOUIS GATHMAN, Chicago, Ill.—Filed Jan. 9, 1893. Serial No. 47,857. (No model.)

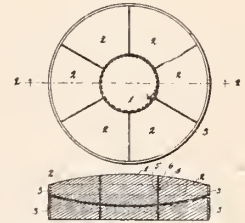

A lens consisting of a plurality of members or sections forming in conjunction with each other a complete lens and secured together side by side in the same plane, each of said members or sections having irrefractive sides.

**DESIGN 23,022. BADGE.** CHARLES W. GRUBB,



Providence, R. I.—Filed Nov. 14, 1894. Serial No. 528,833. Term of patent 3½ years.

**DESIGN 23,929. CLOCK CASE.** WILLIAM A. HOENEMAN, Clifton, assignor of one-half to Franklin P. Hoeneman, New York, N. Y.—Filed

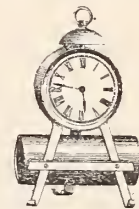

Nov. 9, 1894. Serial No. 528,351. Term of patent 7 years.

**TRADEMARK 25,767. JEWELRY AND PRECIOUS STONES.** HENRY ALKAN, Buffalo, N. Y.—Filed Nov. 14, 1894.



*Essential feature.*—The representation of a spread eagle carrying in its talons a ring mounted with a precious stone. Used since Oct. 1, 1894.

# CLASSIFIED INDEX TO ADVERTISEMENTS.

All Advertisements are entitled to one insertion under proper heading. Extra insertions, \$6.00 per annum.  
Extra Headings, \$12.00 per annum.

<b>Art Pottery, Bric-a-brac, Etc.</b>	Page.	<b>Diamond Cutters.</b>	Page.	<b>Ring Makers.</b>	Page.
Bing, Ferdinand & Co., 106 Grand St., N. Y. . . . .	40	Fera, Henry, 10 Maiden Lane, N. Y. . . . .	35	Bowden, J. B. & Co., 192 Broadway, N. Y. . . . .	42
Hinrichs & Co., 29 & 31 Park Place, N. Y. . . . .	43	Fox Bros. & Co., 68 W. 4th St., Cincinnati, O. . . . .	31	Jones & Woodland, 49 Chestnut Street, Newark, N. J. . . . .	11
Straus, L. & Sons, 42 to 48 Warren St., N. Y. . . . .	39	Oppenheimer Bros. & Veith, 35 Maiden Lane, N. Y. . . . .	42		
<b>Assayers &amp; Refiners.</b>		<b>Diamond Jewelry.</b>		<b>Safes.</b>	
Baker, Geo. M., Providence, R. I. . . . .	34	Jeanne, Paul, Bradley Bldg., N. Y. . . . .	42	Mosler, Bahmann & Co., 518 B'way, N. Y. . . . .	39
Le Long, L. & Bro., Newark, N. J. . . . .	44	Leonhardt & Curran, 44½ Maiden Lane, N. Y. . . . .	38		
Rathbone, J., 1-9 Mathewson St., Providence, R. I. . . . .	35	Schroder, D. & Co., 252 Race St., Cincinnati, O. . . . .	33	<b>Sample Trunks.</b>	
U. S. Smelting & Refining Works, 25 John St., N. Y. . . . .	44			Crouch & Fitzgerald, 161 Broadway, N. Y. . . . .	5
<b>Auctioneers.</b>		<b>Diamond Polishing Mills.</b>		<b>Show Cases.</b>	
Boyle, Davis & Goodman, 63 5th Ave., N. Y., 611 Pennsylvania Ave., Washington, D. C. . . . .	40	Arthur Co., The, 86 John St., New York . . . . .	44	Smith, B. & W. B., 220 W. 29th St., N. Y. . . . .	44
Comrie, A. J., 22 John St., N. Y. . . . .	29	<b>Fine Stationery.</b>			
French, J. H., P. O. Box 2775, N. Y. . . . .	39	Parsons & Greene Co., 18 Murray St., N. Y. . . . .	5	<b>Silver Plated Ware.</b>	
Fechner, St. Clair, 612 Pennsylvania Ave., N. W., Washington, D. C. . . . .	43	<b>Gold and Rolled Plate Jewelry.</b>		Pairpoint Mfg. Co., New Bedford, Mass. . . . .	5
H. M. Rich & Co., 21 School St., Boston, Mass. . . . .	42	Foster & Bailey, Providence, R. I. . . . .	3	The Wm. Rogers Mfg. Co., Hartford, Conn. . . . .	40
<b>Badges, Medals, Etc.</b>		Smith, Wm., & Co., 5-7 Maiden Lane, N. Y. . . . .	42	Webster, G. A., Chicago, Ill. . . . .	31
Stockwell, E. R., 19 John St. N. Y. . . . .	2	<b>Gold Jewelry.</b>		<b>Sterling Silver Novelties.</b>	
<b>Bicycles.</b>		Aikin, Lambert & Co., 19 Maiden Lane . . . . .	39	Codding Bros. & Heilborn, North Attleboro Mass. . . . .	2
Keating Wheel Co., Holyoke, Mass. . . . .	34	Carter, Sloan & Co., 15 Maiden Lane, N. Y. . . . .	13	Hagan, White & Co., 243 W. 23d St., N. Y. . . . .	42
<b>Book Marks, Sterling Silver and Gold.</b>		Greene, Geo. F., 111-113 Point St., Providence, R. I. . . . .	16	Kent & Stanley Co., Providence, R. I. . . . .	8-9
Stone Bros., 535 Broadway, N. Y. . . . .	39	Globe Jewelry Co., 119 120 Orange St., Providence, R. I. . . . .	17	Unger Bros., Newark; N. J. . . . .	4
<b>Chains.</b>		Larter, Elcox & Co., 21-23 Maiden Lane, N. Y. . . . .	18	<b>Thimbles.</b>	
W. & S. Blackington, Attleboro, Mass. . . . .	22-23	<b>Horological Schools.</b>		Ketchum & McDougal, 198 Broadway, N. Y. . . . .	39
Kent & Stanley Co., Providence, R. I. . . . .	8-9	Chicago Watchmakers' Institute, Rockford & Chicago, Ill. . . . .	31	<b>Sterling Silverware.</b>	
<b>Clocks, French, English and American.</b>		Parson's School for Watchmakers, Peoria, Ill. . . . .	31	Fuchs, Ferd. & Bros., 808-810 Greenwich St., N. Y. . . . .	38
Jacques, Chas., Clock Co., 22 Cortlandt St., N. Y. . . . .	44	Philadelphia College of Horology, 623 Heed Building, Phila., Pa. . . . .	35	Towle Mfg. Co., Newburyport, Mass. . . . .	40
<b>Cut Glass.</b>		<b>Jewelry, Silverware and Optical Cases.</b>		Wallace, R. & Sons Mfg. Co., 3 Park Place, Wood & Hughes, 16 John St., N. Y. . . . .	43
Clark, T. B. & Co., 860 Broadway, N. Y. . . . .	43	Jackson, S. C., 180 Broadway, N. Y. . . . .	5	<b>Tool Manufacturers and Dealers.</b>	
<b>Diamond &amp; Precious Stone Importers.</b>		<b>Jobbers, Watches, Diamonds, Etc.</b>		Allen, Benj. & Co., Chicago, Ill. . . . .	29
Friedlander, R., L. & M., Ltd. 30 Maiden Lane, N. Y. . . . .	2	Allen, Benj. & Co., Chicago, Ill. . . . .	31	American Watch Tool Co., Waltham, Mass. . . . .	43
Disselkoen, John N., 19 E. 16th St., N. Y. . . . .	13	Aikin-Lambert Jewelry Co., 19 Maiden Lane . . . . .	2-39	Moseley & Co., Elgin, Ill. . . . .	31
Falkenau, Oppenheimer & Co., 40 Maiden . . . . .	44	Myers, S. F. & Co., 48 Maiden Lane, N. Y. . . . .	44	Mossberg Wrench Co., Attleboro, Mass. . . . .	2
Hedges, Wm. S. & Co., 170 Broadway, N. Y. . . . .	12	<b>Musical Boxes.</b>		Oliver, W. W., Buffalo, N. Y. . . . .	33
Kipling, E. E. 182 Broadway, N. Y. . . . .	44	Jacot & Son, 39 Union Square, N. Y. . . . .	2	<b>Trunks and Traveling Bags.</b>	
Kahn, L. & M. & Co., 172 Broadway, N. Y. . . . .	44	<b>Ophthalmic College.</b>		Crouch & Fitzgerald, 161 Broadway, N. Y. . . . .	5
Kipling, R. A., Hays Bldg., N. Y. . . . .	12	Chicago Ophthalmic College, Chicago, Ill. . . . .	33	<b>Watch Case Repairers.</b>	
Lorsch, Albert & Co., 37 Maiden Lane, N. Y. . . . .	44	<b>Optical Goods.</b>		Henry, Peter, Cincinnati, O. . . . .	31
Randel, Baremore & Billings, 29 Maiden Lane . . . . .	13	Geneva Optical Co., Chicago, Ill. . . . .	31	The Planchamp & Becker Co., Chicago, Ill. . . . .	31
Smith, Alfred H. & Co., 182 Broadway, N. Y. . . . .	12	Queen & Co., Philadelphia, Pa. . . . .	44	<b>Watch Importers.</b>	
Tannenbaum, L., & Co., cor. Maiden Lane and Nassau St., N. Y. . . . .	21	Spencer Optical Mfg. Co., 15 Maiden Lane, N. Y. . . . .	29	Hyde's, J. E., Sons, 22 Maiden Lane, N. Y. . . . .	42
		<b>Pens, Pencils, etc.,</b>		<b>Watch Keys.</b>	
		Aikin, Lambert & Co., 19 Maiden Lane, N. Y. . . . .	2-39	Clark, A. N., Plainville, Conn. . . . .	44



## Special Notices.

Rates 75c. per insertion for notices not exceeding 3 lines (25 words); additional words 2 cents each. If answers are to be forwarded, postage stamps must be enclosed. Two insertions, 15 per cent. off; three insertions, 20 per cent. off; four insertions or more, 25 per cent. off. Payable strictly in advance. Display cards on this page will be charged at \$2.00 per inch for first insertion, subject to same discount as above for subsequent insertions.

Under the heading of **Situations Wanted** on this page advertisements will be inserted for One Cent a Word. This offer refers to **Situations Wanted only**. Payable strictly in advance. If answers are to be forwarded, postage must be enclosed.

## Situations Wanted.

Notices under this heading **ONLY** are charged at one cent a word, payable strictly in advance. If answer are to be forwarded, postage must be enclosed.

**TRAVELING** salesman, 15 years with one firm, thoroughly acquainted, established trade in larger cities from Pittsburgh, west and south, wants good line, moderate salary. Address A1, care JEWELERS' CIRCULAR.

**WANTED**—By experienced man with good trade in Ohio, Indiana and Michigan, position as salesman with first-class manufacturing or jobbing jewelry house, line of watches preferred. Address F. J. G., CIRCULAR Office.

**BY** experienced watchmaker, salesman and engraver, competent to take charge. Address Parker, Lock Box 401, Madison, O.

**ENGRAVER** and salesman desires position at once. Middle States preferred. Salary \$16. Reference given for character and ability. Address Commerce, care JEWELERS' CIRCULAR.

**SITUATION** wanted by first-class watchmaker and fair engraver. Own tools. Iowa preferred. J. H. Lipper, Grinnell, Ia.

**POSITION** wanted as jeweler and repairer; can do some setting (ring making a specialty); 12 years at bench; best of reference from last employer. J. Voight, care Hoefner & Zimmerman, 176 Broadway, New York.

**BOOKKEEPER**, absolutely reliable and competent to take charge of office, credits and collections, desires to make a change; for number of years in similar position in watch and diamond line; excellent references. Address Amiable, 170, Care JEWELERS' CIRCULAR.

**SITUATION WANTED**—A steady position by young man to finish trade; 1½ years' experience; watch and clock repairing; plain letter engraving; good habits; full set of tools. Address F. H. C., No. 1 Academy St., Norwich, N. Y.

**YOUNG MAN, 19 YEARS, WOULD LIKE A POSITION WITH A JEWELRY CONCERN WHERE HE CAN ADVANCE HIMSELF. EXCELLENT REFERENCES. ADDRESS OFFICE, CARE JEWELERS' CIRCULAR.**

**WANTED**, to finish trade, 3 years' experience. Best of references. Address T., care of John Burgess, Bloomfield, Iowa.

**SALESMAN**—A first-class man, with unquestionable references as to ability, character, &c., direct from one of the largest houses in N. Y. city, desires an engagement to travel in New England, New York city and near-by towns. Would like line of fine gold jewelry or any manufacturer's line. H. J., JEWELERS' CIRCULAR.

**A PRACTICAL** watchmaker and jeweler, with some capital, wishes a position as manager or partner in a first-class retail jewelry store. Address O. G. N. T., care of JEWELERS' CIRCULAR.

**FIRST-CLASS** watchmaker, 18 years' experience in fine and complicated work and adjusting of high grade watches, desires permanent position with important firm, appreciating good work. High wages expected. Address Adjuster, care of JEWELERS' CIRCULAR.

**A FIRST-CLASS** watchmaker would like position after January 1st. Full set of tools. References if required. Address Whitcomb, care of JEWELERS' CIRCULAR.

**WATCHMAKER**.—First-class all-around man. Twelve years' experience. Full set of tools. A1 references. Salary, \$20 per week. Address S., 145, care of JEWELERS' CIRCULAR.

**FIRST-CLASS** watchmaker wants permanent situation with good house. Full set of tools. A1 references. Address W., 755, care of JEWELERS' CIRCULAR.

**HAVING** an extended acquaintance with both the wholesale and retail trade throughout the west, I should like to form a connection with some manufacturing jeweler as traveling salesman; fine goods preferred; salary moderate. Address Traveler, care JEWELERS' CIRCULAR.

**WANTED**—A position by a married man; age 35; has had seven years' experience in retail, eight years traveling; A1 salesman; prefers New York City or near by trade; reference guaranteed. A., care JEWELERS' CIRCULAR.

**WANTED**—A position as representative in New York City and neighborhood trade; manufacturing jeweler preferred; best reference; ten years' experience; salary or commission. H., care JEWELERS' CIRCULAR.

**IF** you want good watchmaker, engraver and optician write to me; can give reference from present employer. Good reasons for changing. Salary not as much my object as steady employment. Am a hustler. Address P. O. Box No. 107, New Madrid, Mo.

## Help Wanted.

**WANTED**—A TRAVELER WELL ACQUAINTED WITH NEW ENGLAND JEWELRY TRADE. ONE WHO HAS HANDLED SILVER PLATED WARE. ADDRESS M., CARE JEWELERS' CIRCULAR.

**WANTED**—A good engraver and jeweler to go south; permanent employment to right man. Address H. S., Box 32, Lynchburg, Va.

**WANTED**—Experienced traveling salesman to carry a leading and well-known line of spectacles and eyeglasses. Samples easily carried. Liberal commission. Address Optics, care JEWELERS' CIRCULAR.

**WANTED**—A young man as salesman for city and vicinity for mountings and mounted diamond goods, or salesman to carry the line as a side line on commission. Address Diamond, care JEWELERS' CIRCULAR.

## For Sale.

**FOR SALE**—Marvin Safe fitted for watch business. Also travelers' outfit and other fixtures. Herzog, Goldsmith & Frank, 52 Maiden Lane.

**THE** greatest bargain ever offered.—The oldest established jewelry store in a railroad center of 1,400. Send me your address and I will give you full information. Address Watch Inspector, care JEWELERS' CIRCULAR.

**FOR SALE**—Well established jewelry and optical business in best business city of the south; population 30,000; only three other stores; established over five years and has been well advertised; best located store in city, nice size and moderate rent; have carried stock of \$6,000 to \$7,000; inventories now about \$4,000; could be reduced to suit purchaser; fixtures, etc., about \$1,200; sales have run from \$8,000 to \$10,000 and profits \$3,300 to \$3,800 per annum; stock consists of American watches, diamonds and a general line of jewelry, which is all in good shape and desirable goods; have made specialty of optical business and this alone pays \$1,800 per annum; would like to correspond with parties having cash, or who could give good paper and to whom I will show my books, etc., to verify my statements; only reason for selling is, am compelled to engage in out-door business on account of my failing health. Address E. A. Williams, 105 Main St., Lynchburg, Va.

## Miscellaneous.

**WOULD** like to negotiate in person with a reliable sterling silver manufacturing house, or a jobber in silver and kindred goods, with a view to recommending their agent, and making my store a depot for their goods. Mine is the handsomest jewelry store in Newark, N. J., located in a fire and burglar proof building; could devote a large and elegant wall case, and 20 feet of show case for display of goods; I deal principally with the better class of people; leading wholesale jewelers as references. Address Business, care JEWELERS' CIRCULAR.

## To Let.

**TO LET**—52 Maiden Lane, store and basement; also two upper floors. Apply Louis Herzog, on the premises.

## Business Opportunities.

**PARTNER WANTED**—For a favorably and well-known manufacturing jeweler, with a first-class trade and good line of staple gold goods; one to act as salesman and to furnish \$6,000 to \$8,000; said amount wanted to increase the business. For particulars address C. S. Carter, P. O. Box 1228, Providence, R. I.

**WANTED**.—Partner, with some money, in successful, established engraving business. Will be taught the trade, if desired. Best references given and asked. Large profit on investment assured. Address Engraver, A. B. C., care of JEWELERS' CIRCULAR.

**S** AID GRANDMAMMA TO GRANDPAPA,  
**S**LEEPING AT HIM WITH FURROWED BROW  
**E** NOUGH OF LIFE I HAVE NOT SEEN,  
**N** OR CAN I SPARE MY EYE-SIGHT NOW.  
**C** OULD I REGAIN MY SIGHT OF YOUTH,  
**E** 'EN FOR A FEW SHORT YEARS TO COME,  
**R** ICHES, OFFERED, WOULD FIND ME LOTS,

**O** N PARTING FROM MY TREASURE WON,  
**P** ERHAPS I CAN YOUR WANTS RELIEVE,  
**T** O TRY WILL BE MY CHIEF DESIRE  
**I** N BRINGING TO YOU SUCH RELIEF AND  
**C** OMFORT, AS I CAN ACQUIRE,  
**A** ND GRANDPA QUICKLY DONNED HIS HAT,  
**L** AUGHING CONFIDENTLY ALL THE WHILE,

**M** AKing HASTE, WHILE GRANDMA SAT  
**F** ORGETTING ALL, SAVE THAT HIS SMILE  
**G** AVE HER GOOD CHEER, FOR SINCE THAT  
TIME HER

**C** ONSTANT THOUGHT IS ONE OF THANKS  
**O** ER ALL OTHERS FOR GLASSES GOLD, MADE  
BY THE SPENCER OPTICAL MFG. CO.

## WHEEL CUTTING.

We make a specialty of Wheel Cutting, Demagnetizing and Watch Repairing for the trade. Complete plant. Send for price list.

**THE WINSLOW & PENNEY CO.**  
608 Masonic Temple, - CHICAGO.

**A. J. COMRIE,**

**AUCTIONEER,**

22 John St., N. Y.

**SPECIAL SALESMAN OF WATCHES, DIAMONDS, BRIC-A-BRAC, FOR ESTABLISHED JEWELERS.**

WRITE FOR PARTICULARS.

THE STAR OF EMPIRE WESTWARD TAKES ITS WAY

# WESTERN SUPPLEMENT

## of THE JEWELERS' CIRCULAR

**Chicago Office: Room 517, Inter-Ocean Building.**

VOL. XXIX.

CHICAGO, WEDNESDAY, JAN. 9, 1895.

NO. 24.

### Chicago Notes.

Jules Racine is sojourning at Old Point Comfort.

Anderson Bros. succeed S. Anderson, Wilmar, Minn.

Juergens & Andersen Co. closed their factory one day (Wednesday) for stocktaking.

J. W. Spence, of the Racine Jewelry Mfg. Co., Racine, Wis., and daughter Grace, were visitors to the city the past week.

The Pneumatic Clock Co. have nearly completed their system for the North Side Criminal Court building. It is placed there on probation.

H. Van der Heydt, 461 Ogden Ave., will move Jan. 15th into his own building just completed, on Ogden Ave. near Harrison St.

A meeting of the Chicago Engravers' Association will be held the coming week, day not yet decided on, to perfect organization, which was interrupted by the busy season.

The Waltham Mfg. Co., a retail concern in the Chicago Opera House block on Clark St., H. H. Rouse, proprietor, is out of business—store vacated. The concern was formerly of Denver.

Mr. Schauweker, of Schauweker & Chalmers, returned from his eastern holiday visit Thursday. Mrs. Schauweker (née Glatz) accompanied her husband on his return.

George D. Lunt, western traveler for the Towle Mfg. Co., returned Saturday from the Pacific Coast. Mr. Lunt found sufficient trade on the coast to extend his trip for a longer time than on any previous visit.

H. W. Duncanson, 759 W. Madison St., has disposed of his jewelry interests to Rose, Carter & Co., and will devote his undivided attention to the Chicago Optical & Electrical Co., of which he is proprietor.

The regular monthly meeting of the Chicago Jewelers' Association was held the 2d inst. without important action. The special meeting of the banquet committee was postponed owing to the absence of chairman Sercomb in Milwaukee.

Fire starting on the third floor of 132 Fifth Ave., at 1 o'clock, Thursday afternoon, caused a damage by water to the stock of Gordon & Morrison, wholesale jewelers, to the amount of \$2,500 to \$3,000. Gordon & Morrison occupy the entire second floor, the third being used for tailoring purposes. Fire originated from a gasoline explosion in the tailor shop. The damage was confined to water, which poured in streams from the floor above. The firm have been in business three years. Loss fully insured and business only interrupted twenty-four hours, so far as undamaged stock was concerned.

A portion of the goods stolen from the Brethauer Jewelry Co. have been recovered. They were in the possession of a Findlay, O., pawnbroker, who claimed he purchased them from traveling men. Mr. Remillet, a jeweler of that city, wrote the Dueber factory that their goods had been sold at reduced price. An investigation followed and it was discovered the goods complained of were a part of the Brethauer robbery. Mr. Brethauer was telegraphed to. Taking his stock book with him, he identified thirteen watch cases, two movements, and two hair chains as his, the value of which was \$100. Two other cases were later recovered by the chief of police of Findlay and returned to the owner, and a gold watch has been recovered from a pawnshop in this city. About \$2,000 worth of goods was taken by the robbers when they looted Brethauer's store here, after locking the secretary of the company in the vault.

### Daring Burglary and Prompt Capture of the Culprits.

ATLANTIC, Ia., Jan. 3.—While Al. Tharnish, the Exira jeweler, was at supper, Saturday night, a burglar pried open the back entrance and entered the store. He took \$1,500 worth of jewelry, literally stripping the show cases. He went to Weston, a mile from Exira, joined a confederate, who drove him to Audubon, where they put up their team at the livery barn of J. H. Tharnish, father of the jeweler who was robbed.

The police in all the neighboring towns were promptly notified of the robbery, and Tharnish, of Audubon, told the city marshal about the two men who had put up their team at his barn and his suspicions that they were the burglars. The men were found at the Park hotel and a search of their effects revealed the entire lot of stolen jewelry. The men were placed under arrest. The burglar gave his name as Deering, of Des Moines, and the confederate, an old man, as Williams, of Atlantic.

### A Receiver Wanted for the Stock of W. T. Marcy.

INDIANAPOLIS, Ind., Jan. 5.—The Dennison Mfg. Co., Chicago, yesterday filed a complaint in Superior Court, asking for a receiver for the jewelry stock of William T. Marcy, 38 W. Washington St. The complaint alleges that the defendant is indebted to the plaintiff in the sum of \$693.83 and asks judgment for \$1,000. It is averred that the defendant possessed prior to Dec. 18, 1894, a stock of jewelry worth \$30,000, which he has since sold and delivered to his wife.

It is asserted that this transfer was made without consideration and for the sole purpose of deceiving and defrauding the defendant's creditors, there being at the time of the alleged sale an indebtedness equal to the full appraised value of the stock. It is alleged that William T. Marcy is yet in the possession of the stock which is in danger of being removed or molested by him to the detriment of the creditors.

### E. M. Blauvelt Makes an Assignment.

COLUMBUS, O., Jan. 7.—E. M. Blauvelt has filed chattel mortgages aggregating \$5,000, and subsequently assigned.

The liabilities are estimated at \$15,000 and the assets at \$10,000.

E. & J. Swigart, Cincinnati, O., are clearing up stock and preparing to renew for the Spring trade. They had a very successful season in all branches.

# LOOK AT THESE PRICES!

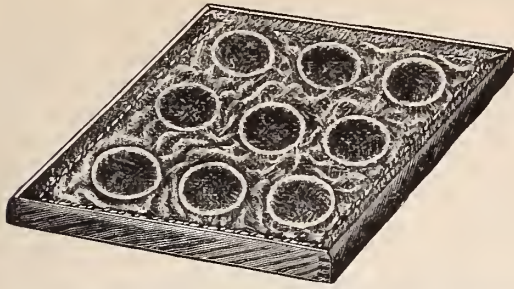

Show Case Trays with Solid Walnut Frames lined with Fine Red Silk Plush, with Old Gold Border, and made to stack one on top of the other. Size, 11 3/4 x 11 3/4.

For Gents' Watches, each, . . . . . \$1.25  
For Ladies' Watches, each, . . . . . \$1.25  
For Rings, each . \$1.25. For Chains, each, . \$1.25  
For Charms, ea., \$1.25, for Card Jewelry, plain, ea., 80c.

Subject to the usual discount for cash.

## CHRISTMAS IS COMING.

Make your Stock Attractive and Fresh. It does not cost much and will add largely to your SALES.

## BENJ. ALLEN & Co.,

141 & 143 State St.,  
CHICAGO, ILL.



FINE PLUSH BOXES.

WATCHES, CLOCKS,  
DIAMONDS,  
SILVERWARE  
and JEWELRY.

For Gents' Watches, per dozen, \$3.00 For Ladies' Watches, per dozen, \$3.00  
For Rings, per dozen, \$2.00 For Ear Drops, per dozen, \$1.50  
For Six Tea Spoons, per dozen, \$9.00 For Six Table Spoons, per dozen, \$15.00  
For Child's Set, per dozen, \$9.00 For Six Coffee Spoons, per doz., \$15.00  
For Sugar Shell, per dozen, \$9.00 For Butter Knife, per dozen, \$9.00

Subject to the usual discount for cash.

DON'T FORGET THE JEWELERS' CIRCULAR PUBLISHING CO.'S BOOK LIST when in want of any technical book in the Jewelry or Kindred Trades.



## GENEVA OPTICAL CO., CHICAGO.

CATALOGUES.

- PART 1—General Catalogue of Optical Goods.
- " 2—Microscopes and Accessories.
- " 3—Photographic Cameras, Stocks and Supplies.
- " 4—Thermometers, Barometers and Meteorological Instruments.

### PRESCRIPTION WORK

Made with Promptness and Accuracy.

### OCULISTS' or OPTICIANS' OUTFITS.

Trial Cases.  
Ophthalmoscopes.  
Lens Measures.

CORRESPONDENCE SOLICITED.

### THE PLANCHAMP & BECKER CO.

Makers and Repairers of

### WATCH CASES,

Gold and Silver Plating —  
of Watch Cases a Specialty.

UNEXCELLED FACILITIES.

62 and 65 East Washington St., Chicago.

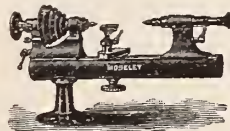

One of the best of the very best.

QUALITY IS THE STANDARD OF VALUE FOR WHICH WE COMPETE

### "THE MOSELEY."

"A Bread Winner" for the watchmaker. We furnish you good lathes and chucks, while the other fellow furnishes the wind.

MOSELEY & CO., Elgin, Ill.

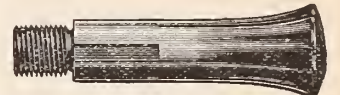

No. 2 Moseley Wire Chuck has length, strength, accuracy.

MORE ADVANTAGES—LESS COST.



CHICAGO  
ROCKFORD

## Watchmakers' Institute

211-20 WALNUT ST., ROCKFORD, ILL.

Write for New Terms

G. D. PARSONS, Principal

### PARSONS : SCHOOL

—FOR—

### WATCHMAKERS,

PEORIA, ILL.

Send for Circular and Terms.

PARSONS & CO.

### G.A. WEBSTER

42 & 44 Madison St., Chicago, Ill.

### Manufacturer,

AND WESTERN AGENT FOR

E. G. WEBSTER & SON, of Brooklyn, N. Y.

A. F. TOWLE & SON CO., of Greenfield, Mass.



EST. 1870.

DR. PETER HENRY  
SPECIALIST IN

### Watch Case Diseases

Key Winders changed to Stem Winders

Hunting Case changed to O.S.

English Case changed to fit American movements.

Can be cured at

53  
LONGWORTH ST.  
Cincinnati, Ohio.

DIAMOND CUTTERS and POLISHERS looking for desirable and permanent positions should apply direct to

## FOX BROS. & CO.,

68 and 70 West 4th Street,

CINCINNATI, OHIO.

### San Francisco.

Zach C. Oppenheimer, of Seckels & Oppenheimer, New York, has returned home.

Mr. Adams, Reed & Barton, and Fred Sadler, Dennison Mfg. Co., were recently in this city.

W. A. Schwartzkopf, jobber in the Thurlow block, received a Christmas present of a bouncing baby boy.

Rumors are afloat to the effect that early in the new year there will be changes in the well known house, The California Jewelry Co.

Henry Dinkelspiel, formerly of S. P. Dinkelspiel & Co., has left for New York, where he intends to locate permanently. He was at various times connected with several New York houses.

### Pacific Coast Notes.

George Hastings is selling out his store in Santa Barbara, Cal., at auction.

J. P. Alverson, Fresno, Cal., is contemplating opening in Guadalupe, Cal.

E. L. Swartsel, jeweler, Santa Ana, Cal., is conducting an auction of a portion of his stock.

S. W. Thompson & Co., Salem, Ore., have remodeled their store in elegant fashion.

The case of Black vs. the Standard Jewelry Co., South San Francisco, was decided for the plaintiff and judgment given for \$30. Black argued his own case.

Articles of incorporation for the Empire Jewelry Co., Seattle, Wash., have been filed with the county auditor. Incorporators, Dexter T. Sapp, Joseph F. Baer and Albert Moyer; capital stock, \$50,000.

The jewelry store of H. M. Funk, 931 5th St., San Diego, Cal., narrowly escaped being robbed recently. A burglar cut a hole in a pane of glass in one of the windows and was about to enter, when he was frightened away.

The jewelry store of A. Fagan, Fresno, Cal., was burglarized recently, the burglar entering through a hole in the front window. When inside the man ran against a contrivance arranged to shoot burglars and narrowly escaped being shot; the report, however frightened him away, his haul being only three or four cheap watches. The explosion of the pistol set fire to some of the decorations of the store and a conflagration was narrowly averted. The burglar has not been captured.

The new auction license ordinance was tested in Sacramento, last week, and found wanting. F. T. Keelan and D. G. Cronin, jewelry auctioneers, were arrested on the charge of violation of the new law and made their defense on the ground that the ordinance is unconstitutional, being a restraint of trade, etc. The Sacramento law requires nearly \$1,000 paid in advance, which is practically prohibitory, and now that it is found to affect several resident auctioneers who have

been doing a regular business in the jewelry auction line, the council men are regretting their hasty action. Judge Devine gave it as his opinion that the law was invalid, being unreasonable, oppressive and discriminating against one class of legitimate auctioneers.

### Louisville.

Herman Korfage has opened a store on 4th St. near Walnut St.

J. Gortikan has opened a new store on Market next to Jackson Sts.

J. C. Kowenberg and C. J. Rauch, with Geo. H. Kettman & Co., leave on their Spring trips about the 10th.

Geo. H. Kettman & Co. have moved to their new store on Market St. near 6th, where they will have more room.

The Louisville Trust Co. have discontinued the sale of the Schultz stock, which they have in charge and have been selling at auction.

Alf. W. Mayer has gone on the road for the Non-Retailing Co., succeeding Mr. Kersting who retires owing to ill health. Mr. Mayer will have his headquarters in Louisville.

D. E. Shoupe, optician, has removed from his temporary quarters to his old stand on 4th St. between Walnut and Greene Sts., which have been thoroughly remodeled since the recent fire.

### Detroit.

J. E. Durham, Douglass, Mich., has moved into more commodious quarters.

Henry Statz, representing W. H. Bell, Evart, Mich., was in the city last week purchasing goods.

Hugh Connolly, formerly of Black & Connolly, has taken a position with jeweler Adolph Enggass.

Herman C. Dittmar, of Camp & Dittmar, Saginaw, Mich., was last week married to Miss Laura Catterfield.

Albert G. Bedford, junior member of R. H. Bedford & Son, Ionia, Mich., was married last week to Miss Grace S. Long, of that city.

J. R. Caston, a Cincinnati jeweler, was called to Detroit last week on account of the sudden illness of his wife. Before he could reach here she died.

Two traveling salesmen passed through Detroit last week. They were J. Goldsmith, with William Loeb & Co., and Mr. Cook, with the Woodland-Cook Co.

The proprietors of the Wayne Hotel recently purchased a complete silver service from F. G. Smith & Sons. It was on exhibition in the firm's show windows last week.

George L. Lowe, representing Kennedy & Koester, went to St. Ignace, last week to attend the sale of W. M. La Clare's jewelry stock. Kennedy & Koester closed Mr. La Clare out on a chattel mortgage. The sale took place Thursday, Jan. 3d.

The following Michigan country jewelers were in Detroit last week: W. L. Tobey, Ovid; W. Walton, Richmond; William Ambler, Northville; C. E. Montford, Utica; J. S. McGlaughlin, Wyandotte; George Chambers, Mt. Clemens; Dan McCarthy, Marine City; George Hamilton, South Lyons; and Herman Jacobs, Sand Beach.

### Cincinnati.

O. E. Bell and John Holland are on the sick list.

Chas. Jacobs, Chicago representative of Homan & Co., was at the Cincinnati factory last week.

M. Loeb, Chicago representative of the Wadsworth Watch Case Co., was in Cincinnati last week.

Rudolf Jacobs, who has been ill for the past two months, has recovered sufficiently to go down to his store.

Morris Hahn, who has represented Henry Hahn & Co. for several years, has become associated with D. Jacobs & Co.

John Holland intends remodeling his place of business this year, putting the wholesale department on the entire second floor of his building and making a specialty in the retail department of desk items.

Information was received at police headquarters Friday that a five-karat diamond had been found on a thief in Chicago. It is thought it may be the big diamond the Simper Bros., of Cincinnati, had stolen from their show window in 1893.

A. A. Oakes, Bloomington, Ill.; E. L. Feyler, Portsmouth, O.; Fred Bruner, Circleville, O.; and J. H. Smith, of Nerswager & Slambaugh, Xenia, O., were in Cincinnati last week and all reported fine holiday trade and good prospects for the year '95.

### Kansas City.

A dispatch from Leavenworth states that the window of Mrs. Esther Lyon's store was smashed by one who gave his name as John Doe, with intent of robbery.

By mutual agreement M. F. Barger has withdrawn from the firm of Woodstock, Barger & Hofer, wholesale jewelers. The business will be continued under the name of Woodstock, Hofer & Co., who will receive and pay all debts of the old firm.

### Minneapolis and St. Paul.

S. H. Clausin is expected home from the Pacific Coast about Feb. 1. He went away early last Fall to spend the Winter.

The engagement of Louis Gans, traveling salesman for H. E. Murdock, Minneapolis, to Miss Helen K. Whittier is announced.

The C. A. Roebuck Co., Minneapolis contemplate removing their business to Chicago some time during February. They have already rented an office there.

Mrs. Chamberlain, wife of W. H. Chamberlain, Minneapolis, has gone to Indianapolis, to attend the funeral of her brother, the Rt. Rev. David Buell Knickerbocker, Bishop of the Episcopal Diocese of Indiana.

Rentz Bros., Minneapolis, have rented a large room adjoining their present quarters and are enlarging their manufacturing plant to twice its former capacity.

### Indianapolis.

J. W. Hudson is preparing to put up a new store room in Fortville, Ind.

S. T. Nichols, of Nichols, Pee & Co., was confined to the house by illness, the past week.

Louis F. Ott, Veedersburg, Ind., was here last week visiting friends and buying goods.

Chas. W. Lauer, of Baldwin, Miller & Co., spent several days last week with Herman Lodde, Lafayette, Ind.

H. L. Kepler has removed his stock from Fairmount, Ind., to Andrews, Ind. He will add it to a small stock recently purchased from G. W. Autenrith.

Wm. T. Marcy sold out Dec. 31st to his wife, Annie Marcy, from whom he had borrowed money to conduct his business. It is thought that his creditors will get 50 per cent.

A woman giving her name as Mrs. M. Miller and claiming to live on the South Side, called at H. D. Burgheim's jewelry store last week and looked at some diamond rings. She asked to take one valued at \$50 to show to a friend, promising to return it in half an hour. She never returned—Burgheim left for Louisville to secure her arrest. He secured the ring.

### Syracuse.

J. C. Mannering, Camillus; O. E. Ward, Phoenix; and C. H. Fuller, Manlius, were in town buying goods the past week.

Alfred Miller, formerly of Syracuse, but now with J. H. Johnston & Co., New York, is on a ten days' visit here with old friends.

Wm. A. Wightman, for R. F. Simmons & Co., and W. H. Browne, for the Wilcox Silver Plate Co., were the first traveling representatives to appear in Syracuse since the holidays.

The Standard Watch Co. will move to East Syracuse, where they have been offered ground for a factory, besides a bonus in money for locating there. The understanding is that the company shall employ at least 50 men daily on an average, and that not more than two shall receive more than \$25 a week.

### The Cincinnati Wholesale Jewelers' Association Meet and Banquet.

CINCINNATI, O., Jan. 4.—The Cincinnati Wholesale Jewelers' Association held their annual meeting at the Burnet House, Jan. 2, and elected the following officers: President, A. G. Schwab, of A. G. Schwab &



A. G. SCHWAB, PRES.

CINCINNATI WHOLESALE JEWELERS' ASSOCIATION.

Bro.; vice-president, H. C. Walton, of the Wadsworth Watch Case Co.; secretary and treasurer, Joseph Becker, Cincinnati agent of Jos. Fahys & Co. and the Brooklyn Watch Case Co.; directors, Aaron Herman, of D. Schroder & Co., and C. A. Sanders, of the Dennison Mfg. Co.

A brief business session followed in which the president appointed a committee consisting of A. Herman, John Dallar, L. Gutman, Ferd. Phillips and J. Frohman, to draft a circular petition to the manufacturers asking their co-operation in keeping the jewelry trade in the legitimate channels, by selling only to the legitimate jobbers. The committee will report at an early called meeting.

After business was disposed of, the assembled gentlemen adjourned to the banquet hall and sat down to a very fine spread. The president was called upon for a speech and he responded with a telling speech, complimenting the associate members, and eulogizing the growth of the association. He laid particular stress upon the importance of work the associat'on

could accomplish if they would all proceed in harmony.

Perfect good will seemed to flow, as well as spirits, and soon nearly every member present had the floor. Jake Dorst related a new joke. Aaron Herman expressed his happiness in epigrammatic language. S. M. Peck was animated and voluble; he had the floor 19 times to the amusement of his friends. L. Gutman having just joined made a neat initial speech and Mr. Frohman told how glad he was he was living. Altogether the occasion was one of jollity to those present.

The following houses were represented: D. Schroder & Co.; Alfert Bros.; Ben. Lindenberg & Co.; Henry Hahn & Co., Peter Henry, S. M. Peck, John Holland Gold Pen Co.; Jonas, Dorst & Co.; Oskamp, Nolting & Co.; A. & J. Plaut; A. G. Schwab & Bro.; Wadsworth Watch Case Co.; Homan & Co.; L. Gutman; Frohman, Wise & Newman; Dennison Mfg. Co.; Jos. Becker and W. G. Eichelberger & Co.

### Souvenirs of the Season.

As has been their custom for some years past, the Pairpoint Mfg. Co., New Bedford, Mass., have issued an elegant calendar for 1895. It is 10x15 inches in dimensions, and depicts four charming maidens, each a type of beauty, ascending a stair and laughing bewitchingly at the onlooker. This view is enclosed within an artistic panel of embossed roses and daisies. The company's advertisement announcing gold and silver plate, rich cut glass and decorated Limoges china is printed in blue. The calendar is in the lower corner. Altogether the ensemble forms a dainty souvenir well worthy preserving.

From the Nicholl & Roy Co., printers, 16 Dey St., New York, is received a convenient calendar consisting of six board leaves showing a month's dates on each side, strung on rings.

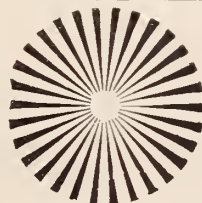

### OPTICIANS' SCHOOL.

If you want a GOOD ROOF over your head, come to our school. We want EARNEST STUDENTS, leave the rest to us, we do not want diploma hunters.

The Chicago Ophthalmic College and Hospital,

H. M. MARTIN M. D., PRESIDENT. 607 VAN BUREN ST., CHICAGO  
Being the oldest and most favorably known College of Theoretical and Applied Ophthalmic Optics in America, having more thoroughly qualified opticians in the field than all other so-called schools combined.

# D. SCHRODER & CO.,

## WHOLESALE JEWELERS AND IMPORTERS,

Diamonds, Loose and Mounted at Big Bargain Prices. Sole Agents for West and South of Howard Watches at Greatly Reduced Prices. Send for our Catalogue, it will please you.



252 RACE STREET, CINCINNATI, O.

### Connecticut.

William T Hoyt, assistant superintendent of Holmes & Edwards Silver Co., has left for the south to be gone all winter.

Colonel W. J. Leavenworth and daughter Bessie, of Wallingford, left this week for the west. Col. Leavenworth goes partly on a business trip.

W. R. Rogers, Meriden, Post Department Commander of the Grand Army of the Republic, installed the new officer of Standing Post, of New Britain, this week.

Col. W. J. Leavenworth, has been elected president of the Arcanum Club, Wallingford's leading club, and C. H. Tibbets has been elected secretary and treasurer of the club.

The management of the Standard Electric Time Co., of Waterbury, has been assumed by Leroy Upson, who lately retired from the assistant treasurership of the Waterbury Watch Co.

The Upson Jewelry Co., Waterbury, are having a successful auction removal sale, and expect to dispose of their \$20,000 worth of goods at auction in the next 15 days. They have secured another fine store, in the Warner Block, and will occupy it April 1.

Samuel George Simpson, George A. Simpson and Henry W. Simpson have each a \$5,000 interest in the estate of the late Samuel Simpson, of Wallingford, and Alvina A. Parker and Adeline E. Parker \$3,000 each. They have asked that Charles H. Tibbets be appointed trustee of the estate and the Probate Court has granted their request.

By a bad fire in Litchfield, Jan. 4, which destroyed the three story brick block, one of the best business blocks in town, the jewelry store of Ernest Pratt, was badly damaged. The damage to his stock is \$12,000; insured for \$7,500. The fire broke out at 1.30 o'clock and spread rapidly. It started, as is supposed, by the explosion of a Rochester lamp in the rear of Mr. Pratt's store.

### Pittsburgh.

M. Bonn & Co. have improved their new storeroom by adding incandescent lamps.

Louis Evans, for 10 years watchmaker with G. W. Biggs & Co., is now with T. P. Bedilion.

Frank Lang with Corcoran & Vilsack, will open a manufacturing plant with West, White & Hartman.

G. E. Giffin has started up a watchmaking and engraving establishment at 67 Federal St., Allegheny.

B. E. Arons and Al Pratt have departed on a six weeks' tour including the Bermudas, Cuba and Mexico.

A. E. Shutterly, of Mt. Pleasant, Pa., was closed out last week by S. Myers. Pittsburgh firms are interested to some extent in this failure.

Sol. Cerf, late of M. Bonn & Co., will shortly start anew at 533 Wood St. Mr. Cerf is now in the east, purchasing stock.

G. L. Ruff, agent for Mrs. C. B. Ruff, 636 Penn Ave., will be sold out Jan. 10th, by the sheriff on judgments of L. M. Smit, \$1,303.10.

M. Bonn & Co. have employed a new western representative, Samuel Guttman, and during the coming season will have four travelers on the road.

William Milchsack, 94 5th Ave., was sold out Jan. 2, 1895, by the sheriff on judgments of Miss Milchsack, \$150; I. Ollendorf, \$1,050; and the Pearl Laundry, \$766.96.

Fleming Bros., 61 4th Ave., have dissolved partnership, and A. R. Fleming will continue in the business in Wilkesburg. F. Beymer, formerly with R. Siegelman, of Homestead, will be with Mr. Fleming.

The jewelry store of C. A. Lindsey, Johnstown, Pa., was closed on the afternoon of Jan. 5th by Sheriff Davison, on executions by Dr. E. L. Miller and other creditors. The claims against Mr. Lindsey aggregate about \$1,000.

Visiting jewelers during the past week were: J. W. Carter, Beaver; Geo. V. Brady, Washington, Pa.; Bert Neville, Dawson, Pa.; Will F. Brehm, Rochester, Pa.; Wm. Hunt, Uniontown; G. L. Klesnan, Butler; Mr. Bygate, Scottsdale and P. J. Mason, Jeannette.

Charles Lohman had a narrow escape from death last Thursday night. He was attacked by a footpad, and showing fight, was stabbed twice. He is now at his home in a serious condition. William Heeren was held up on the same night, and is now in the hospital from injuries received.

G. L. Ruff, who, since his late failure, has been employed by Geo. W. Biggs & Co., was given a hearing last week before alderman J. V. McMasters, charged by J. Grafner, wholesale jeweler, 77 Fifth Ave., with obtaining goods valued at \$121.63 on credit upon the representation that he owned no one, while but a short time previous he had given a judgment note to I. Ollendorf for \$1,303.10.

### Buffalo.

The following out-of-town jewelers were here recently: Geo. Engel, Springville, N. Y.; Mr. McCoy, of Mundie & McCoy, Tonawanda, N. Y.; Geo. E. Crandall's Son, Springville. They all report good holiday business.

Seneca Baker, the oldest jeweler of Medina, N. Y., died last Tuesday evening from heart disease. Mr. Baker closed his store about 8.30 o'clock and he and his wife started for home. When they had gone but a short distance he sank to the sidewalk without being able to utter a syllable. Assistance was hastily summoned but he had breathed his last before the physician arrived. The deceased was 66 years of age.

The matutinal orange has created almost an industry for itself. There are orange sets consisting of knives, cups and spoons; there are orange holders, orange peelers, and orange spoons. These are none of them adaptations after implements, but things new, desirable and beautiful.

365 DAYS AHEAD OF THEM ALL.

Apply at Once for Catalogue and

BEATING BICYCLES

SEE THAT CURVE

FACTORY, HOLYOKE, MASS.

AGENCY FOR

*Jewelers make good agents, and get more profit on one bicycle than on six average watch sales.*

**We Know** THAT WE CAN GIVE YOU BETTER RETURNS ON YOUR OLD GOLD AND SILVER OR WASTE THAN ANY ONE ELSE. TO PROVE THIS STATEMENT GIVE US ONE TRIAL.



**GEO. M. BAKER,**

GOLD AND SILVER REFINER  
AND SWEEP SMELTER.

**PROVIDENCE, R. I.**

### Providence.

M. Levy, Toronto, has been registered at the Narragansett Hotel, the past week.

D. Oppenheimer, of Baltimore, has been in town inspecting the sample lines of the local manufacturers.

O. C. Devereux & Co. have been closed the past week making extensive changes and improvements in their factory.

The business of J. W. Richardson & Co., of this city and New York, will be continued by William Morris and Harry Butts.

R. A. Schultz, formerly salesman for E. L. Logee & Co., is now engaged with the Union Eyelet Co., in a similar capacity.

McNair & Burlingame, manufacturers and dealers in jewelers' findings, have been succeeded by J. P. Burlingame & Co., and will continue at 226 Eddy St.

Mrs. Nannie E. Holt, widow of the late Albert Holt, has been appointed administratrix of her husband's estate with bonds at \$20,000, the Fidelity and Deposit Co. of Maryland being surety.

Ora E. Case, for several years bookkeeper for Fred I. Marcy & Co., and Charles Lord, formerly of Lord & McLaughlin, have formed a copartnership for the manufacture of jewelry, as Lord & Case.

Clark & Johnson, assignees for W. L. Balou & Co., commenced an auction sale Saturday morning, to dispose of the remaining stock of this concern. Their liabilities amount to \$78,079.00, while the assets are only inventoried at \$20,967.08.

William S. Greene and Randolph A. Greene, of this city, have purchased the interest of Charles H. Grout in the copartnership heretofore existing under the name and style of George F. Greene & Co., 111 and 113 Point St. Mr. Grout has retired and the three Greenses will continue the business at the same place under the same name.

The annual Winter reunion of the New England Manufacturing Jewelers' Association will be held on Tuesday evening, Jan. 29, at the rooms of the Falstaff Club. The executive committee are putting forth great energies to make this occasion surpass anything in the history of the organization, and an entirely new departure in the nature of the entertainment will be provided.

### Boston.

Charles F. Morrill, of the Morrill Bros. Co., was re-elected commodore of the South Boston Yacht Club last Wednesday evening.

George H. Lloyd, optician, will remember the happy New Year wishes of his employes very pleasantly throughout 1895, for they were accompanied by a very handsome gold mounted meerschaum that he is now engaged in coloring after the most approved style of the art.

The new watch concern, whose intention to locate in Waltham was first announced

by THE CIRCULAR several months ago, is beginning to materialize, despite the denials which were current soon after the facts were first made public. Its name is to be the Rumford Watch Co., it is stated, and machinery for the plant is under construction. Present plans contemplate the beginning of watchmaking this year with about 100 employes.

### Canada and the Provinces.

George Alex. Gray and Jos. N. Babson, doing business as the Canada Plating Co., Montreal, have dissolved partnership.

C. H. A. Grant, manager of the Montreal Watch Case Co., Montreal, attended the funeral of the late Sir John Thompson at Halifax.

J. H. McClelland, jeweler, formerly of Peterboro, Ont., has opened business at Norwood, Ont., apparently oblivious of the present strong competition.

Henry Birks & Co. received a letter from Doulton & Co., Burslem, Staffordshire, England, last week warning them against a scoundrel who is representing himself to be connected with their firm. He is making a tour through the States and endeavoring by the use of the firm's name to get a temporary loan. In one case he has represented himself to be a son of Sir Henry Doulton.

### Newark.

Wm. L. Kaiser has given a mortgage for \$8,300.

Mr. Jones, of the new firm of Jones & Woodland, has moved from Brooklyn to this city, where he will locate permanently.

Joralemon & Ingraham will soon succeed A. Joralemon & Co., the members of the firm being A. Joralemon, head of the present firm, and Harry K. Ingraham, for many years representative for Alling & Co.

The employes of Larter, Elcox & Co. presented W. C. Woodland with a handsome etching upon his retiring from the superintendency of this firm. Mr. Woodland has taken charge of the factory of the new firm of Jones & Woodland.

### Springfield, Mass.

Gustave Young, for 20 years an engraver for Smith & Wesson and recognized as one of the leaders in this branch of work in this country, died last week. Mr. Young was born in Germany where he learned the trade of engraving, and came to this country 43 years ago. He first located in Hartford, Conn., and engaged as a contractor in Colt's fire arms factory, but entered the employ of Smith & Wesson in 1868. His engraving was considered as fine as any extant and specimens were exhibited at the expositions in Berlin, Vienna, London, Philadelphia and other places. He received a very fine medal for that shown in the Austrian city. His finest work was done for the World's Fair when he exhibited a pistol engraved in gold

relief work, the labor on which was worth more than \$1,500. This was the most elaborate and expensive pistol ever shown in the United States.

George W. Bradley, an itinerant watchmaker, who was convicted of embezzlement in police court some months ago, for failing and refusing to return a watch which he had taken to repair and who appealed to the Superior Court, settled the case by pleading guilty and paying a fine of \$30. He had hardly got rid of this case when he was taken in tow by a Connecticut deputy sheriff who took him to the Nutmeg State to explain what he did with about \$600 worth of property. Bradley represented that he was a member of the firm of Geo. W. Bradley & Co., and took the jewelry, some of it of a very fine nature, to be repaired by his partner. When it was not returned on time the owners become suspicious and looked him up. Bradley returned the property, very little of which had been repaired and as it could not be proven that he had tried to sell any of the goods he could not be held on a criminal charge.

Neafach's jewelry store, Troy, N. Y., suffered slightly by fire Jan. 2d.

## HENRY FERA,

IMPORTER AND CUTTER OF

# DIAMONDS,

10 MAIDEN LANE, NEW YORK.

ESTABLISHED

AS AN IMPORTER SINCE 1871.  
AS A CUTTER SINCE 1878.

I hereby take pleasure in announcing that I have just opened, in addition to my present establishment at 10 Maiden Lane, new DIAMOND CUTTING AND POLISHING WORKS AT No. 60 FULTON STREET, fitted up with all modern improvements by The Arthur Co.

My workmen are the very best in the trade and my long reputation as an expert guarantees the finest work possible.

CUTTING FOR THE TRADE A SPECIALTY.

## A Complete Establishment

MEANS

### PERFECT WORK

In every detail of

## ASSAYING, REFINING AND SMELTING.

The proof that mine is such lies in the prompt and satisfactory returns invariably given all my customers. ARE YOU ONE?

HIGHEST MARKET RATES FOR OLD GOLD AND SILVER.

J. RATHBONE,

Nos. 1 to 9 Matthewson St., cor. Cove, Providence, R. I.

## News Gleanings.

K. D. Monkman, jeweler, Wyoming, Ill., has sold out.

C. M. Poe, Norton, Kansas, has moved to Nevada, Mo.

A. M. Frankel & Co., Mt. Vernon, N. Y., have sold out.

C. B. Rich has opened a jewelry store in Micanopy, Fla.

Nelson Peterson succeeds Matt Simmer, Henderson, Minn.

Levy Lubin, Watertown, N. Y., is closing out his stock.

F. L. Aronson, Buffalo, N. Y., has given a mortgage for \$250.

Jacob Stadler, Toledo, O., has discharged a mortgage for \$800.

Kent & Gorham succeed C. W. Gorham, New Richmond, Wis.

Louis Arntz, Des Moines, Ia., has sold out to M. A. Davidson.

H. Schenkein & Sons, Pueblo, Col., have quit business in that city.

W. E. Masters, West Superior, Wis., has given a bill of sale for \$500.

L. J. Hooper, Cripple Creek, Col., recently suffered loss by fire.

A. W. Garbett, Picton, Ont., has been succeeded by Mrs. Garbett.

Fred W. Farrar, Somerville, Mass., has given a mortgage for \$750.

M. A. Davidson, Des Moines, Ia., has given a mortgage for \$1,745.

Jeweler Green will remove from Amsterdam, N. Y., to Buffalo, N. Y.

Ramsey & Ramsey, Grand Junction, Col., have opened up a jewelry store.

W. F. Tappan, Washington, D. C., has taken out a trust deed for \$350.

W. S. Allan has been admitted to the firm of Jas. Allan & Co., Charleston, S. C.

The store of W. J. Brouse, Potsdam, N. Y., was damaged by fire a few days ago.

F. C. Sands, Sag Harbor, N. Y., has a judgment note issued against him for \$363.

Thomas Dunlap, and J. J. Wandell, jewelers, Jefferson, Tex., have filed deeds of trust.

R. W. Chamberlain, Des Moines, Ia., has been served with a landlord's attachment for \$560.

Gotthelf & Voellinger, Vicksburg, Miss., have removed to 103 N. Washington St., opposite the old stand.

The dwelling of H. A. Youmans, Tipton, Ga., was recently burned. The loss was fully covered by insurance.

Frank Smith, jeweler, Hudson, Mich., has bought the Fisher block and has put in a stock of jewelry and clocks.

At Donnellson, Ia., the jewelry store of Meinhardt & Mattern was robbed last week of a large amount of jewelry.

Edward Crane, jeweler, Granite Falls, Minn., and Maud Dodge, daughter of Dr. Dodge, were married recently.

A. L. Dickman's store, Sedalia, Mo., was recently damaged to a considerable extent by fire. Fully insured.

The jewelry store of J. J. Compton, Halstead, N. Y., was gutted by fire recently. Mr. Compton was fully insured.

The jewelry rooms of Fred E. Way, Charlestown, N. H., were recently entered by burglars, and 30 watches taken.

The death occurred recently of Lysander P. Coe, Amsterdam, N. Y. He was a jeweler until his retirement about a score of years ago.

The Lovell Jewelry Co., Racine, Wis., have made an assignment to Herman Proehl. Liabilities are \$2,000 and assets about the same.

The Pestalozzi Jewelry Co., of Milwaukee, Wis., have been incorporated by Frank H. Brice, John F. Reiff and H. R. Pestalozzi, with \$2,000 capital.

R. E. Meyers, jeweler, Hazelton, Pa., has entered upon his duties as general manager and superintendent of the Freeland Light, Heat and Power Co.

A. P. Clayton, trustee of Baldwin & Co., St. Joseph, Mo., is conducting an auction sale of the balance of the stock of the firm, remaining in his hands.

Mrs. Kittie Innes, wife of jeweler Frank Innes, Moravia, N. Y., ill for several years past with consumption, died at her residence recently, aged 37 years.

Fire Friday afternoon, caused by a gas explosion in the store of George O. Willey & Co., Haverhill, Mass., caused a loss to George H. Hussey, jeweler, of \$5,000.

Baker & Worrell, Washington, Pa., will remove their jewelry store to the rooms now occupied by insurance agent W. C. Baldwin. The front will be remodeled and the rooms refitted.

Judge Osborn Dec. 29th signed an order denying a motion to discharge attachments in the suits against Simon Rumpf and Joseph Mayer, Seattle, Wash., brought by the Towle Mfg. Co., Unger Bros. and Henry Cowen.

Adolph Meyer, lately of the firm of Max Meyer & Bro. Co., Omaha, Neb., and more recently at the head of the musical department of Hayden Bros., has resigned his position. It is said he will go into business for himself.

James Robinson, assistant manager for Perkins Bros., Pougkeepsie, N. Y., has left for Enniskillen, Ireland, where he has been summoned to settle the estate of his uncle, Robert Robinson, a banker and millionaire bachelor.

It was discovered on the morning of Dec. 31 that burglars had entered the jewelry store of T. D. Cockerill, Sandusky, O. They loaded his safe upon a wagon and hauled it into the country where it was blown open. No valuables were secured.

Negotiations are going on toward securing a large watch and clock factory for

Stauffer, Pa. Quite a large sum has already been raised to secure its location there. The plant, if secured, will give employment to from two to three hundred men.

On the night of Dec. 25, at 9 o'clock, an officer noticed sparks falling from the roof of the building occupied by Artes' jewelry store, Evansville, Ind., and he sent a still alarm. When an investigation was made it was discovered that the chimney was burning out.

Some enterprising thief, a few days ago, drew the staple which secured a show case belonging to A. J. Shellman, optician, Grand Rapids, Mich. The show case stood at the foot of the stairs just inside the stairway. Opera glasses and magnifying glasses to the value of \$66 were taken from it.

The authorities of Keyport, N. J., are investigating the origin of a recent fire which destroyed Ulrich's jewelry store among other places. The stores were in Ogden's building. The circumstances connected with the destruction of the stores led to the belief the fire was started with criminal intent.

E. F. Winegar, Kenosha, Wis., who sleeps in the back part of his store, awakened the other night and thought that his room was full of coal gas. He saw some one running away and called the police who discovered that an attempt had been made to chloroform Mr. Winegar through the keyhole, the object being undoubtedly to rob him.

Nowlan & Co., Richmond, Va., have been succeeded by the Nowlan Co. The capital stock is not to exceed \$50,000, and not to be less than \$20,000, divided into shares of \$100 each. These are the officers for the first year: President, Thomas Nowlan; vice-president and general manager, Robert Macomber; treasurer, Robert L. Winston; directors, Thomas Nowlan, Robert Macomber, Robert L. Winston, Blair Bolling, and James B. Winston.

An injunction was recently issued upon request of E. R. Clapp, owner of the Clapp block, Des Moines, Ia., to restrain Kennedy, the jeweler, from disposing of his stock. Mr. Kennedy has a five years' lease upon the store room in which he conducts a jewelry store. Recently he had an auction and before the injunction could be served all the goods were sold. Mr. Kennedy, it is understood, will go out of business. Mr. Clapp secured the injunction in an effort to hold Mr. Kennedy to the five years lease.

Marsh & Henwood, Binghamton, N. Y., whose stock was badly damaged by fire recently, will continue business as soon as the necessary arrangements can be made. They will probably remain in the same location, as the building was not seriously damaged by the fire. During the excitement attending the fire a tray containing diamonds was dropped. It is believed by Mr. Henwood that a pair of earrings and a scarf pin were picked up by a spectator



**Curiosities in Night Clocks.\***

(Continued from p. 33, Jan. 2.)

IN the *Architecture de Schubler* are reproduced two apartment clocks made in 1724. One of them had a lamp behind the dial consisting of a lens projecting its image enlarged on the ground. The other was a magic lantern projecting the image of a dial on the wall. These two night clocks were of a large size, very elegant in shape, and profusely decorated.

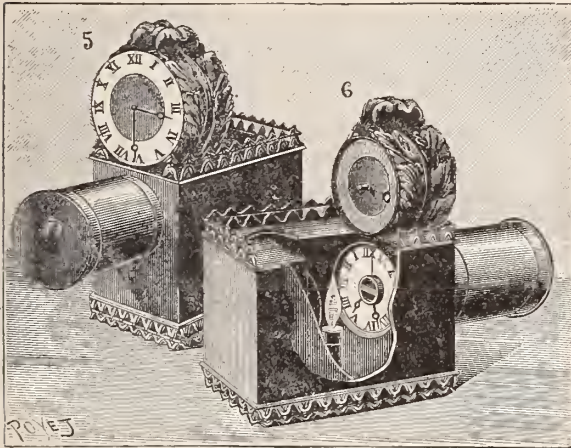

CLOCK LAMP.—FIG. 5, EXTERIOR VIEW; FIG. 6, DETAIL OF INTERIOR MECHANISM.

There is in Planchon's collection a clock which belongs to the Empire period. (Figs. 5 and 6). It consists of a square case having in front the object glass of a magic lantern, behind which there is a glass dial with hour marks painted on it. The hands on this dial are moved by means of an almost invisible gearing connected with the

Through this apparatus an enlarged image of the dial is projected on the wall or on a screen.

In 1828, Rehait took out a patent for a magic lantern used in connection with a watch, which is at the Arts et Métiers, Paris.

Great many night clocks were made during the Empire. Those most generally used consisted of an unpolished dial with hour marks painted black, the dial being circled with an elegant metal setting (Fig. 7); at the center was a brass *rosace* masking a watch movement, a night lamp was placed behind, lighting up the dial. The stand, of graceful outlines, was of chased brass. It exhibited, as a rule, a human figure kneeling on a column and holding up the dial.

Fig. 8 shows a night lamp, constructed in 1819 by Gabry, clock maker, of Liancourt, France. It is of a system similar to that of the night lamp reproduced in Fig. 3, and somewhat reminds us of ancient Indian clepsydræ. It consists of two china receptacles juxtaposed, which are connected by means of a pipe placed at the base of the partition dividing them. A dial is painted on the face of a sheet-iron plaque rising above the partition. The two receptacles were filled with lamp oil, and a wick dipped in the front one. Upon the surface of the oil contained in the back receptacle rested a floater held by a wire rolled around a pulley, the latter being mounted on a horizontal axis connected with the center of the dial. The floater, gradually sinking with the level of the oil, caused the hand to move on the dial. Such clocks must have been rather deficient as regards accuracy.

In modern times a great variety of night clocks have been made, many of which are night lamps in the shape of elegant vases provided with an unpolished glass dial. The movement is hidden by a *motif* placed in the center of the dial, as was the case with the Empire clock described above (Fig. 7).

A current pattern is a porcelain or bronze lamp of familiar shape with a globe of unpolished glass bearing hour marks painted in black. A graceful woman, or an infant grasping with one hand at a branch of flowers in relief thrown across the body of the lamp, points out with one finger of the other, the time on the globe which is a revolving dial. There are also all kinds of *bibelots* showing a night lamp combined in a curious manner, with a clock of ordinary use.

Fig. 9 shows a plump little boy, dressed as Auriol, the old clown. He strikes a cymbal with one hand against the other, which rests on the top of a drum, which is a clock, and holds with his right hand a lamp

in the shape of a *bilboquet*, surmounted with a globe. Another pattern is a mediæval herald, holding on one side a shield or escutcheon with a dial in the center, and on the other a torch which is an electric lamp, with a godrooned globe of unpolished glass.

**Bench Tools.**

A CORRESPONDENT enumerates the repairer's bench tools as follows: The first *sine quâ non* is a convenient bench, with needful accessories; a good assortment of tools, especially plyers, one or two pair of them with brass linings, for handling polished pieces without marring; a pair filed thin for straightening up damaged teeth, and others for special as well as for general work. Same with tweezers; a good assortment fitted up for different jobs; small points for balance springs, and a pair especially to hold jewels while cleaning them; they are easily made from a pair of brass tweezers, and should be a little flaring or funnel shaped. Regular watch brushes,



FIG. 9.—MODERN NIGHT CLOCK.

if new, should be rubbed down, until fit for use, on a piece of sandpaper, about No. 3, tacked to a flat board, taking care to wash them thoroughly before using; in fact, wash brushes as often as they need cleaning. Pinchers and stakes of hard wood are useful in making or reducing end shakes, and, if carefully used, will not mar the plate. A lathe is a convenience, especially in making small tools, and is almost indispensable. As good work as the average at the present time may have been done before the advent of the American, or split chuck lathe. Every watchmaker should have a "bow"-lathe, or "bench-turns" as they are called in England; a set of arbors, collets and whalebone bows, which latter should be well tapered, and have tension on them *only* when in use. The total cost is trifling, and when once familiar with their use, one will not be without them under any consideration.

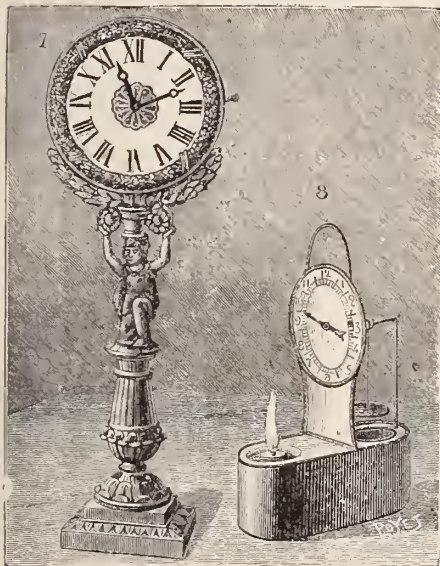

NIGHT CLOCKS.—FIG. 7, EMPIRE CLOCK; FIG. 8, GABRY CLOCK.

works of a clock placed on the top of the case, which clock serves in the daytime. Behind the inside glass dial is a lamp.

\*Adapted from *La Nature*, Paris, France.

## The History of Spectacles, Telescope, Etc.

(Continued from p. 34, Jan. 2.)

THE first undoubted report of the use of spectacles for assisting weakened eyesight is to be found in a letter, written in 1299, in which the writer says that his great age brings with it many infirmities, and that he would not be able to either read or write without his spectacles (occhiali), which had recently been invented to the great benefit of old persons with weakened eyesight. Redi, who quotes this letter, places the time of the invention between 1280 and 1311; an old chronicle of the St. Catherine monastery in Pisa mentions the name of the friar Alexander de Spina, who practiced the art of grinding spectacle lenses at the end of the 13th or beginning of the 14th century. Alexander de Spina died at Pisa in 1313. This assumption is supported by the testimony of a friar of the same monastery, Jordan di Rivalto, of St. Catherine, who, in a discourse delivered by him in 1305, calls attention to the useful invention of spectacles; he says, they are a recent invention, nearly 20 years old, and that he had known the inventor personally.

This might lead us to believe that de Spina was the actual inventor; this assumption is contradicted however, by the engraving on a tombstone in the church Maria Maggiore, in Florence, which says: "Here reposes Salvino degli Armati, of Florence, the inventor of spectacles. May God pardon him his sins, 1317." The most satisfactory solution would be, perhaps, that Armati was the actual inventor, while de Spina contributed largely toward introducing them by grinding the lenses.

The invention appears to have been adopted rapidly; in the 14th century we find the spectacles mentioned quite frequently, as a well-known aid for weakened eyesight. The art of grinding lenses must have issued quickly beyond the monastery walls, because in some writings of the 14th century we find that the art was practised by regular tradesmen in all the large towns of Italy, Germany, Holland, etc. Alexander von Humboldt says that spectacles were known in Haarlem, Holland, at the beginning of the 14th century.

When reviewing the entire course of development of the invention of spectacles,

we will find that it is fairly long. The ancients already understood the grinding of spherical lenses from crystal and glass, and very probably used their magnifying power. The art of manufacture and the remembrance of their effectiveness disappear in the middle ages, until Alhazen again revived them. This mention proved to be an incentive, although not attended by immediate consequences; it penetrated the cloister walls, and attracted the attention of scientific monks. Their first endeavor was to increase the magnifying power much beyond the ordinary—simple microscopes to enlarge very minute objects; less for spectacle lenses. Necessity required at time to grind lenses of large focus, and these next, assisted the eye, the accommodation for seeing things close by having been lost by reason of old age. Thus the spectacles were invented, or, rather, composed, and one of the greatest possible boons was conferred on mankind. The merit of the invention belongs to the Italian friars Salvino degli Armati and Alexander de Spina; they are in all justice entitled to the honor "of having their graves kept green," and their names resuscitated from possible oblivion after 600 years.

According to Maurolycus, it was the custom in the 15th and 16th centuries to designate the spectacles for aged people not according to their focus, but according to the age of the person. Common opinion was that spectacles should commence to be worn from the 40th or 45th year on. The first lenses had a focus of 36 inches and were called No. 40. Those for 50 years had a focus of 24 inches; for 60 years, 16 inches. From this will be seen that the opticians of those days had arranged a certain scale, based on a series of observations, sufficiently correct for ordinary cases; but a change from this scale was considered short of botchwork and highly injurious to the eye requiring such spectacles. This was, of course, a rather primitive style of optics. Short-sighted people fared still worse, and, of course, it was better to desist from wearing concave glasses altogether.

The progress in optics of those early ages, however, was simply one of routine, and rude to the last degree. This state of things prevailed for three hundred years, almost no advance either in the theory or practice of optics being noticeable. This is so much more remarkable because art, science and mechanics commenced to develop; the three centuries are those of the most importance in the history of civilization—the art of printing was invented. America discovered, the way to India around Cape Horn, discovered etc. But great inventions ripen

slowly, and their progress is often interrupted by pauses, to be succeeded by a renewed impetus.

Such an advance was made in the 17th century. Telescope and microscope—instruments calculated to produce new epochs in sciences,—appear almost simultaneously at different places, one remote from the other, so that it is difficult to name the true original locality. Italy and Holland both contend for the honor of the invention, and each of these nations again mentions different names. The old writers contradict one the other, or else leave the question entirely unsolved. The present tendency is to regard the Middleburg lens grinders Hans and Zachariah Jansen (Joanides), father and son, as the true inventors. The foundation upon which this view is principally based, is a writing of the priest Borelius, which appeared in 1655, in which he seeks to establish the invention of the telescope. He mentions several significant documents, to wit: a judicial testimony taken in 1655 of Johann Jansen, a son of Zach. Jansen, in which he deposes that his father had invented the telescope. Mrs. Sara Gödanda, sister of Zachariah, also states that she had often seen her brother construct telescopes. In support of this, the writing of Borelius also contains a letter of one Wilh. Borell, born in Middleburg in 1591, in which the latter calls himself an old friend of Zach. Jansen, and asserts that Hans Jansen and his son Zachariah were universally regarded as the inventors of those optical instruments which he had frequently seen, and describes more closely.

From this description, however, it appears almost beyond a doubt that they were rather compound microscopes. According to Borell, they were about 18 inches long; the tube was gilt, and about 2 inches in diameter; it stood upon a pedestal. The small objects laid upon this pedestal were greatly magnified when looking through the tube. This testimony, therefore, plainly means one of the fancifully gotten-up microscopes, such as were in use even as late as last century. But their sale seems to have not been very extensive at first. Borell as well as Johann Jansen always speaks of only two instruments, one of which was made for Prince Moritz, of Nassau, and the second for Prince Albrecht. Johann Jansen also says that these short telescopes remained in use until 1618, after which he and his father made long ones—

(To be continued.)

**Engravers' Border Wax.**—Bees' wax, one part; pitch, two parts; tallow, one part; mix.

## Philadelphia College of Horology

Is not the largest but is the finest school in the country. A practical school to learn watch-making, engraving, and jewelry repairing. One tuition pays for all branches. Send for prospectus.

**F. W. SCHULER, PRINCIPAL,**  
1213 Filbert St., Philadelphia, Pa.  
Write for particulars of our corresponding course.

## HAVE YOU RECEIVED OUR PRICE LIST? OF DIAMOND MOUNTINGS.

If not, send your business card and we will send you one.



Manufacturing Jewelers  
OFFICE AND FACTORY,

**LEONHARDT & CURRAN,**

57 Maiden Lane, New York.

**FERD. FUCHS & BROS.**  
**SILVERSMITHS,**  
MAKERS OF STERLING SILVERWARE,  
808-810 Greenwich St., New York.



# L. STRAUS & SONS,

IMPORTERS AND MANUFACTURERS,



China, Pottery and Glassware, 42, 44, 46 & 48 Warren St. and 116 Chambers St., N. Y.  
PARIS, CARLSBAD, RUDOLSTADT, LIMOGES, STEINSCHONAU.



## THE LATEST NOVELTY IN BIBLE BOOK-MARKS.

MOUNTED WITH

Sterling Silver or Gold Ornaments,

ON ALL SILK RIBBONS, 8 1-2 INCHES LONG  
WITH APPROPRIATE QUOTATIONS

**WOVEN IN THE SILK.**

Nine different quotations. Ribbons in the following colors: Purple, black, white and lilac. Can be sold profitably at a popular price. Made only by

**STONE BROTHERS,**

535 Broadway, NEW YORK.



SPECIALTY: SALES OF  
**JEWELRY BRIC-À-BRAC**  
AND  
ARTICLES OF VERTU



KETCHUM & McDOUGALL,  
MANUFACTURERS  
GOLD & SILVER THIMBLES,  
GOLD COLLAR BUTTONS,  
AUTOMATIC EYE-GLASS HOLDERS  
198 BROADWAY N. Y.

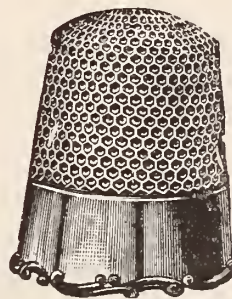

ILLUSTRATED CATALOGUE SENT ON APPLICATION

### SAFES FOR JEWELERS.

MOSLER, BAHMANN & CO., 518 BROADWAY  
NEW YORK.  
Patent Fire and Burglar Proof Safes.

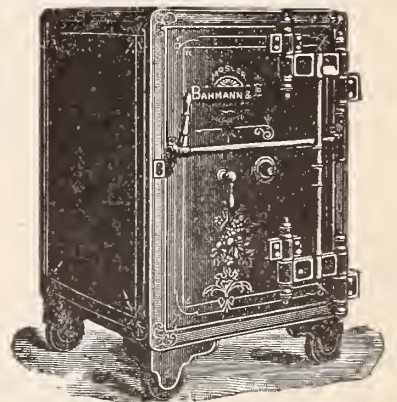

Large Assortment Always on Hand.  
Send for our Representative.  
Special Safes to Order.  
Jewelers' Safes a Specialty.

## AIKIN, LAMBERT & CO.,

CHICAGO BRANCH: 103 State Street.

No. 19 MAIDEN LANE, NEW YORK.

Manufacturers and Exporters  
Gold Pens, Holders, Pencils,



Toothpicks and Novelties

MERCANTILE



FOUNTAIN PEN.



# FERDINAND BING & Co.,

106 GRAND ST., N. Y.

*NEW DESIGNS IN* —————

China Clocks and Gilt Bronze Sets, Fine Painted

Dresden Goods in Vases, Cups and Saucers, and Plates;

Cararra Marble Statuary, French Cabinets and other

Fancy Furniture.

**S**TERLING SILVER . . . . .

TABLE WARE,

Manufactured at

NEWBURYPORT, MASS.



**TOWLE**

MANUFACTURING COMPANY.

CHICAGO OFFICE: 149-151 STATE STREET.

**FLAT WARE AND  
HOLLOW WARE**

STAMPED



IS THE GENUINE.

Manufactured by

**WM. ROGERS M'FG CO.,  
HARTFORD CONN.**

## **BOYLE, DAVIS & GOODMAN,**

*SPECIAL AUCTIONEERS for the Legitimate Trade only.*

**83 Fifth Avenue  
NEW YORK.**

**611 Pennsylvania Ave.,  
WASHINGTON, D. C.**



S. A. BOYLE.



W. M. DAVIS.



CHAS. P. GOODMAN.

**WE PAY ALL OUR OWN EXPENSES. GUARANTEE TO MAKE YOUR SALE WITHOUT LOSS.**

SEND FOR OUR BUSINESS PAMPHLET.

CONSULT US BEFORE PLACING YOUR SALE. ADDRESS ALL CORRESPONDENCE TO OUR WASHINGTON OFFICE.



THE TRADE MARKS ON PORCELAIN AND POTTERY.

PART I.—MARKS ON ENGLISH WARES.

SO many inquiries have been received by THE CIRCULAR from jewelers relating to marks on porcelain and pottery that this journal has decided to publish under this department reproductions of the trade-marks on the pottery wares that jewelers handle. The English lines entering into the jewelry trade are Royal Worcester, Coalport, Doulton, Granger Worcester, Pointons, Minton, Crown Derby, Geo. Jones' Crescent, Cauldon, Wedgwood, Adderley, Hammersley, Bodley, Old Hall, Leeds, and Copeland. They are carried by and may be had at the following importing houses of New York: Le Boutillier & Co., 860 Broadway; L. Straus & Sons, 42-48 Warren St.; Bawo & Dotter, 30 Barclay St.; Chas. Ahrenfeldt & Son, 52 Murray St.; Geo. Borgfeldt & Co., 18 Washington Place, Ferd. Bing & Co., 106 Grand St., Hinrichs & Co., 31 Park Place; Lazarus, Rosenfeld & Lehmann, 60 Murray St.; and Levy Dreyfus & Co., 11 Maiden Lane.



ROYAL WORCESTER.

The Royal Worcester trademark, it will be seen, consists of a circle containing the letter W in continuation, and surmounted by a crown. This mark appears on all the present products of the Royal Worcester Pottery Co., with the exception of the pieces in pierced work which bear the following mark:



GRANGER WORCESTER.

This ware is known as the "Granger" Worcester and in all but its pierced effects, is similar to the above.



DOULTON.

This mark which appears on the ware of Doulton & Co., has as its essential feature the central circle in which are four D's intertwined. Above this is the word, Doulton, and below, the word Burslem, the name of one of the places where the ware is made. Surrounding all is a wavy line surmounted by a crown.



CROWN DERBY.

The mark herewith appears on the products of the Royal Crown Derby Porcelain Co., Limited. Two script D's in opposite directions cross under the crown.



HAMMERSLEY.

Hammersley & Co. use as their trademark simply a crown with their name above and the words "china" and "England" below.



MINTON.

The china of Minton's Limited is easily recognized by the name which appears in the trademark on a globe beneath the crown.



ADDERLEY MARKS.

On the china of Wm. A. Adderley & Co., Longton, the essential feature of the trade mark is a ship. The triangle is a variation.



COALPORT.

The above shows an illustration of Coalport trademark which consists of a crown with the word Coalport in type below. It appears on the porcelain of the Coalport Pottery Co.



POINTONS.

The Pointons mark consists of a representation of the coat of arms of Great Britain and Ireland, surrounded by the words "Pointons, Stoke-on-Trent."



BODLEY.

The Bodley mark is a knot of rope enclosing the name of the works, New Bridge Pottery.



# HENRICHS & CO., 29 and 31 Park Place, NEW YORK.

## IMPORT AND STOCK SAMPLES FOR SEASON OF 1895 READY.

### SPRING 1895. WE WOULD CALL THE ATTENTION OF THE JEWELRY TRADE TO OUR RECENT IMPORTATIONS OF NOVELTIES IN BRIC-A-BRAC, FRENCH CHINA, ETC.

*Wilkes-Barre, Pa.,  
Oct. 27th, 1894.*

*I consider myself benefited over \$2,000.00 by engaging the Col. and can recommend him in confidence to all as he will make money for anyone.—Yours resp'y,  
W. O. Blase.*

My references are all dated, not from interested wholesalers, but from parties for whom I have sold.

### No Stock too Fine or Expensive for me to Sell.

Cater for and get the Largest Lady Attendance of any Auctioneer known. STRICTLY SOBER. TRUTHFUL AND HONORABLE.

A few open dates for the first that need my services.

*Plymouth, Pa.,  
Nov. 19th, 1894.*

*The auction sale made by Col. Fechner in the hardest times this town has ever seen has averaged over 47 per cent. profit on all goods sold by him.—*

*John P. Harris, Jeweler.*

## ST. CLAIR FECHNER,

### \* The Jewelers' Auctioneer. \*

Residence and Address—612 PENNSYLVANIA AVENUE, N.W., WASHINGTON, D. C.

Address until Jan. 10.—Care of Selover's Palace Jewelry Store, Newark, N. J.

If you are in financial straits, if you wish to raise money, if you are overstocked, if you wish to increase custom, if you wish to avoid bankruptcy, write to me, and I will be frank, open and candid, and tell you what can be done, and I will do all I agree. I never disappoint or mislead anyone.

Every Jeweler should have an Auction at least once in five years.

I have positively made NO FAILURE IN TWO YEARS.

Write for my Book, References, Terms, etc. No person will see your letters.

When I am through with my business, if you continue, you will have from 25 to 100 per cent. of new customers.

I am an expert and fully conversant with the values of all kinds of Diamonds, Watches, Jewelry and Bric-a-brac.

I belong to no syndicate or company, furnish no fakers as salesmen. I have one or two capable assistants with me.

*Place the management of the sale in my hands, you handle all the money. Settle with me when all is done. If I have not made money for you, I will pay you \$1,000.00 in cash.*

*I have new and original ways of drawing large lady audiences. They draw the gentlemen buyers that make my sales a success where many so called auctioneers fail.*

# AMERICAN WATCH TOOL CO.

ESTABLISHED 1872.  
INCORPORATED 1894.



THE Webster-Whitcomb

GROWS IN POPULARITY.

PRICES AS LOW AS CONSISTENT WITH QUALITY.

Ask your Jobber for Price List of 1895, or write to us at

Stoney-Batter Works, Chymistry Dist., Waltham, Mass.

When you buy

Cut Glass

You want the best!

That which bears our Trade Mark

Has no superior

And will prove profitable and satisfactory.

## T. B. CLARK & CO., INC.,

860 Broadway, N. Y.,

Factories, HONESDALE, PA.

N. E. Cor. 17th St. & Broadway.



### WOOD & HUGHES, STERLING SILVERWARE MANUFACTURERS

New York Agents for the Derby Silver Co  
FINE QUADRUPLE PLATED WARE,  
No. 16 JOHN STREET, NEW YORK  
206 Kearney St., San Francisco, Cal.  
HASKELL & MUEGGGE, Agents.

**CATSEYES.**

(ORIENTAL.)

**E. KIPLING,**

182 Broadway, New York.

ELEVATOR ENTRANCE, 2 JOHN ST.

**S. F. MYERS & CO.,**

Manufacturing and  
WHOLESALE JEWELERS,  
1895 Issue, No. 39.

**OUR ROYAL CATALOGUE**

Illustrates all that is new, unique  
and desirable in

everything that pertains to jewelry.  
600 pages, size of this publication.  
Free to dealers.

SEVEN DOUBLE FLOORS.  
TWENTY-TWO DEPARTMENTS.

Myers Buildings, 48-50 Maiden Lane,  
33-35 Liberty St., New York.



**PRESCRIPTION WORK.**  
**QUEEN & CO.,**  
1010 Chestnut Street, PHILADELPHIA.  
SEND FOR PRICE-LIST AND ORDER FORMS.

**U. S. SMELTING & REFINING WORKS.**

Sweep Smelting and Assaying, Platinum in Plate and  
Wire. Chemically Pure Copper. Ore and Bullion  
Assays a specialty.

Highest prices paid for old gold and silver.  
Sole manufacturers of Phoenix Flux  
and Eureka Alloy.

**M. WOLLSTEIN.** 25 John St., New York.



OUR  
**SPECIALTY**  
The Largest Stock of  
**CHIMING**  
AND  
**STRIKING**  
**HALL CLOCKS**

ever shown.

**Chas. Jacques**

**CLOCK CO.,**  
22 Cortlandt Street,  
**NEW YORK.**

**Diamond Polishing Machines.**

We build these machines complete with latest improve-  
ments also polishing wheels, tongs, dous, weights,  
shafting, belting, ventilating fans, gear-cutting, die blanks,  
etc. We do general repair work on jeweler's machinery.

**THE ARTHUR CO.,**

General Machine Works,  
**86 JOHN STREET, NEW YORK.**

Sold by all whole-  
sale dealers at manu-  
facturer's price.

**A. N. CLARK & SON**  
**PLAINVILLE**  
**CONN.**

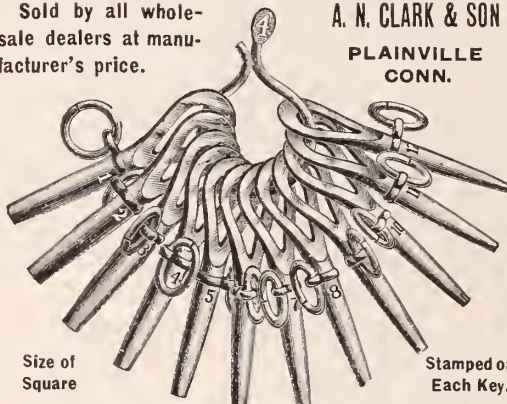

Size of  
Square

Stamped on  
Each Key.

Will quote royalty or price for the manufacturing of articles of real worth.

Manufacturer of the Celebrated

**LOOP WATCH KEY.**

The Best for the Price in the World.  
CROSBY'S JEWELING TOOLS IMPROVED.



**L. LELONG & BRO.,**

**GOLD AND SILVER**

**Refiners, Assayers AND Sweep Smelters,**

SWHORETH CORNER HALSEY AND MARSHALL STREETS,

**NEWARK, N. J.**

**SWEEPINGS A SPECIALTY.**

**ALBERT LORSCH & Co.,**

37 MAIDEN LANE, NEW YORK.

Branch, 167 Weybosset Street, Providence, R. I.

IMPORTERS OF DIAMONDS,

Rose Diamonds, Rubies, Sapphires, Emeralds, Opals, Moonstones,  
Fancy and Imitation Stones, Novelties.

SOLE OWNERS AND IMPORTERS OF

*The Sumatra Gem.*

REGD. UNEQUALLED IN  
BRILLIANCY AND  
HARDNESS

HIGHEST AWARD AT THE COLUMBIAN EXPOSITION, CHICAGO, 1893.

**IT PAYS** TO KEEP IN TOUCH WITH TRADE AFFAIRS. **For 4c. a Week will do it. Subscribe.**  
THE JEWELERS' CIRCULAR.





Copyright by THE JEWELERS' CIRCULAR PUB. CO.

189 Broadway, New York.

Entered at the Post Office in N. Y. as second-class matter.

VOL. XXIX.

NEW YORK, WEDNESDAY, JAN. 16, 1895.

No. 25.

RETROSPECTIVE GLIMPSSES OF THE ANTWERP EXPOSITION.

PART I.

THE Antwerp Exposition, taking place so soon after the great American World's Fair, could not be expected to contain numerous novelties, at least in the artistic lines which alone offer real interest to the readers of THE CIRCULAR. Yet in the course of our rapid review of the more important exhibits, we may happen to find here and there some striking features.

One of the chief attractions of the Exposition was the pavilion containing the collective exhibit of the Antwerp *diamantaires*. This pretty white and gold pavilion, in the Louis XV. style, was built by the architect, Arthur Van de Walle.

Each member of the organization had his display of stones spread on a cream colored velvet cushion, the stones being arranged so as to shape all kinds of *motifs*, among which were: a gathering of brilliants forming the words, *Homage au Roi des Belges*; a star and a crescent sketched with diamonds of various sizes and cuts; a cornucopia out of which diamonds, rubies, emeralds and sapphires seemed to roll; a comet, etc. A large brilliant weighing 200 karats, called the Belgian Star, was greatly admired. Next to the pavilion, and connected with it, there was a lapidary workshop.

In a separate glass case, Van Antwerpen and Van den Bosch exhibited a copy of the sacred elephant of India, cut out of a block of rock crystal, weighing 5 kilogrammes, a work which required five years to execute. The elephant was covered with a gorgeous harness adorned with diamonds, rubies, sapphires and emeralds.

A wonderful specimen of fine cutting

work was a tiny diamond of 1 karat 125° showing fifty-eight facets, perfectly sym-



DIADEM OF DIAMONDS AND PEARLS.

metrical. A microscope was necessary to examine this minuscule masterpiece, which

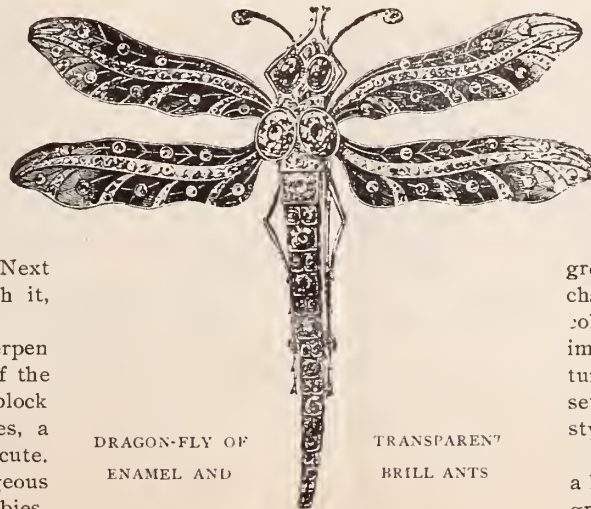

DRAGON-FLY OF ENAMEL AND

TRANSPARENT BRILLIANTS

was executed by Mr. Horemans, a member of the *diamantaire* artisans' club of Ant-

werp, a prominent organization.

Brussels jewelers of note were absent from the exposition. They intend to prepare themselves leisurely for the World's Fair of 1897 in the Belgian capital. Among leading Antwerp jewelers prominent were Van Hemelryck, Anthony, and Rondeau. Besides a great many remarkable works,

Van Hemelryck exhibited a German grand ducal crown of diamonds surmounted with a diamond cross formed of *briollettes* and a diamond dragonfly with wings in transparent enamel adorned with brilliants.

Anthony's quadrangular pavilion decorated in a Moorish style, and looking like

an Oriental temple at once mysterious and elegant, was lighted up the whole day by a subdued electric light, well calculated to show the effect which the jewels should give when worn at soirées or evening parties. Prominent in the exhibit was a handsome emerald *parure*, consisting of 20 different pieces assembled with much taste; a necklace and a diadem formed of brilliants weighing from 18 to 20 karats; and a great variety of brooches, bracelets, *châtelaines*, etc., in blue and amethyst colored enamel framed with brilliants, imitating the jewelry of the eighteenth century; besides *jardinières*, candelabra, table sets remarkably chased in the Regence style.

Rondeau's exhibit was prettily arranged in a little Louis XVI. salon adorned with pale green draperies. Much admired was a dazzling diadem *éclair*, with rays having the appearance of lightning; a lace bow knot in

# J. W. RICHARDSON & Co.,

200 Broadway, NEW YORK.



TRADE MARK.



TRADE MARK.

MANUFACTURERS OF

## SOLID GOLD EMBLEMS, Charms, Pins and Lapel Buttons.

Ask your Jobber to show you his "Blue Book" of Emblems for 1895.

### "MOTHER GOOSE" STICK PINS.

PATENTED NOVEMBER 6 AND DECEMBER 4, 1894.



Bo Peep.



Old Mother Goose.



The Frog that would a wooing Go.



Tom the Piper.



Hev diddle diddle, The cat and the fiddle.



Hot Cross Buns, one a penny two a penny.



Little Jack Horner.



Humpty Dumpty.



There was an old woman tessel up in a basket.



Correct in style.  
Bound to sell.

The best selling line of Stick Pins to date.

Elegant in finish  
Prices Right.



ENAMELED SHIELDS.

The Latest out.  
Engraved Silver and Roman finish.  
Be sure and see them.



The Newest Fad.

Elegantly Engraved and Enameled.



Beautiful Designs.

Prices that defy Competition.



Finished in Silver and Roman.

Put up in our best style.



SHEPHERD'S CROOKS.

New Designs.  
Engraved Silver and Roman finish.  
Be sure and see them.

### CZARINA BUCKLE COLLARETTES

### CZARINA BUCKLE STICK PINS.

The Latest Novelty.

Don't Fail to see them.

GEO. F. GREENE & CO., Manufacturing Jewelers, 111 and 113 Point Street, PROVIDENCE, R. I.



# FOSTER & BAILEY,



100 RICHMOND ST., PROVIDENCE, R. I.

## Manufacturing Jewelers and Silversmiths.

925/1000.

### HEADQUARTERS FOR MANICURE GOODS.



Garters

Link Buttons

Scissors

Neck Chains

Bag Tags

Glove Buttoners

Hat Marks

Chain Mountings

Pen Wipers

Shirt Waist Sets

Emery Balls

Crosses, Earrings

Match Boxes

Solid Gold Locket

Coat Hangers

Locket and Charms

Pocket Knives

Silver Belt Buckles

Pocket Combs

"Mount Hope" Buttons

Paper Cutters

Bracelets and Padlocks

Seals, Button Hooks

Pins and Neck Buckles

And Silver Novelties

Rolled Plate Watch Chains

Without End, all Sterling.

$\frac{1}{10}$  Gold Vest and Dickens Chain.

And also those

### HANDY SETS FOR TOILET IN LEATHER ROLLS.

pale gold with brilliants here and there, looking like Brussels lace on which a few rain drops had fallen; a portrait painted in enamel circled with brilliants, with a gold frame finely chased, a faithful copy of a candlestick, made by Martincourt for Queen Marie Antoinette, a marvel of lightness and grace; the cut shows clearly all the details of this most remarkable work.

A very interesting piece is a diadem of a clear and elegant design consisting of a succession of arches surmounted with pikes and having in the center an open niche partly filled with a *brillollette*. It is formed of diamonds, with pearls running underneath the band.

FRANCK.

(To be continued.)

**Death of K. V. R. Albertson.**

MERIDEN, Conn., Jan. 10.—K. V. R. Albertson, Australian representative for the Meriden Britannia and E. Miller companies, died suddenly in Melbourne last Saturday, aged about 45 years. Intelligence of his death was received at the Meriden factories by cable.

Mr. Albertson was well known to the older traveling men, having represented the Simpson, Hall, Miller & Co., in the United States prior to 1875. He leaves a father, mother and sister in Maywood, Ill.

There is a call for American clocks at Singapore, and a business house in that far eastern city has offered to become the sole agent of an American clock factory, or to sell on commission by special arrangement. With the proposition came an order for clocks. This country began very early to be famous for good cheap clocks, and doubtless Sam Slick was welcome to the Blue Noses because he brought them what they really needed. There are no better clocks for the money than those produced now in this country by the hundred thousand.—New York Sun.

**Fashions in Jewelry and Silver Articles.**

**A LADY'S RAMBLES AMONG THE JEWELERS.**

The manifestation of the back comb is the most conspicuous thing in jewelry at present.

which surround the back comb like a garland or are backed up by it. The most artistic combs are of shell. The contrasts of color and material which shell shows lend to artistic effects. The backs of these shell combs assume various forms. Generally they are irregular in shape. On these the designs are applied. At present these take the form of flowers in colored gold, prominently the rose and the thistle. The thistle is indeed a beautiful ornament. In the more expensive combs certain parts are accentuated by diamonds.

Small side combs are very much in use. The fact that Mr. Cleveland gave his wife a pair ornamented with diamonds will, notwithstanding that the President can scarcely be called an arbiter of fashion, give the side comb additional impetus. The prevailing ornamentation is either light overlay of gold ornaments or diamonds. Colored stones are rarely used, as manifestly women desire their side combs to agree with all their toilettes.

A considerate jeweler has prepared neat cases for stick pins. These are of leather lined with chamois with steps for the pins.

It is observed that careful women are apt to forego their jewel cases and fasten their brooches and pins in large pieces of chamois. These they fold over and the stones are thus protected. Afterward they can be rolled in small compass and laid away in unsuspected places. It is not wise in the burglarizing season to make things too convenient for the burglar.

The opal is seen everywhere. There is a large variety now in new shapes. The old oval is only one form. Curious patterns are wrought out with different shaped opals and diamonds.

ELSIE BEE.

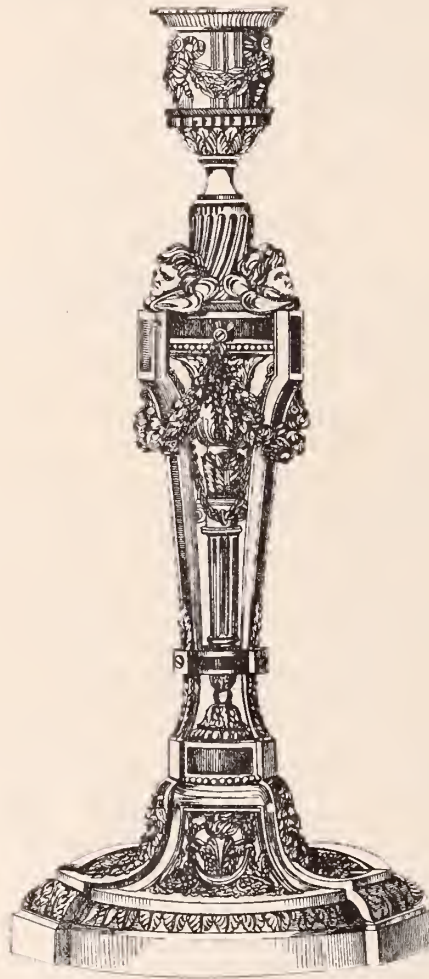

CANDLESTICK, BY MARTINCOURT.

The gala season is partly accountable for this. Still more the small crownless bonnets

Thieves broke in the rear door at Hart Bros. jewelry store, Collins, Mo., and secured \$200 worth of stock.

**THE AMERICAN KNIFE AND SCISSORS SHARPENER.**



TWO-THIRDS SIZE.

For Table Use.

Special Inducements to Jobbers

Manufactured only by the

**MOSSBERG WRENCH Co.,**  
ATTLEBORO, MASS.

Makers of Novelties in Silver and Hardware.

**Practical and Handsome.**

A Silver Plated Knife and Scissors Sharpener, retailing at a popular price. Perfect in action, nothing to wear out. Cutting discs of finest hardened steel. An ordinary sharpness or a RAZOR EDGE can be acquired in a few moments.



TWO-THIRDS SIZE.  
FOR DESK USE.

- FOR SALE BY**  
Benj. Allen & Co., Chicago, Ill.  
F. M. Sproehle & Co., "  
G. A. Webster, "  
L. Straus & Sons, New York.  
E. G. Webster & Son, "  
Oskamp, Nolting & Co.,  
Cincinnati, O.  
Baldwin, Miller & Co.,  
Indianapolis, Ind.  
Eliassof Bros. & Co.,  
Albany, N. Y.  
Thos. Long & Co., Boston, Mass.  
Smith & Patterson, "  
Dame, Stoddard & Kendall,  
Boston, Mass.

*Pairpoint*

# MANUFACTURING COMPANY.

## Gold and Silver Plate



No. 3749. MATCH HOLDER.

WE ARE MAKERS OF THE  
LARGEST AND LOWEST PRICED

.....LINE OF.....

“Crown Pairpoint” China

Rich Cut Glass,

Fine Decorated Art Goods,

.....TO BE FOUND IN THIS COUNTRY.



No. 4908. SMOKING SET.

“WHEN IN DOUBT”

--- BUY ---

✱ PAIRPOINT GOODS.

Factories, New Bedford, Mass.

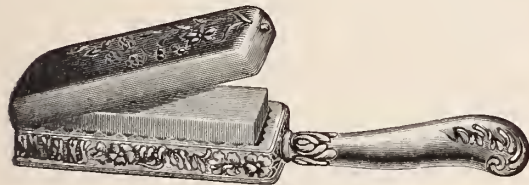

No. 2832. KNIFE SHARPENER.

### HOLIDAY NOVELTIES

.....OF EVERY DESCRIPTION.

**FREE**

OUR LATEST

SILVERWARE CATALOGUE No. 10, or  
CUT GLASS CATALOGUE No. 11

Will be mailed you upon receipt of address.



SALESROOMS:

NEW YORK, 46 Murray Street.

CHICAGO, 224 Wabash Avenue.

SAN FRANCISCO, 220 Sutter Street.

MONTREAL, P. Q., Temple Building.

We sell to the legitimate Jewelry and Stationery trade only.



CHOICE PAPERS

MAKERS OF

## FINE STATIONERY

For Correspondence, Wedding and Business Use, handsomely boxed, specially suited to the Jewelry Trade.

18 MURRAY STREET, NEW YORK.

### ENAMELERS

OF GOLD, SILVER AND PLATED JEWELRY,  
Enameled, Plain and in Colors.

ALSO OF

SOCIETY EMBLEMS,  
YACHT AND COLLEGE FLAGS.

All Varieties of Painted Enamel Work.

### S. S. WILD & SON,

179 Eddy Street, PROVIDENCE, R. I.

Correspondence Solicited.  
Telephone Connection.

### H. M. RICH & CO.,

Jewelry · Auctioneers,

21 School Street,  
BOSTON, MASS.

### CRITCH & FITZGERALD.

Jewelry Trunks  
and Cases,  
161

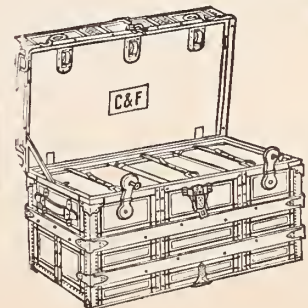

Broadway,  
Bet. Cortlandt and  
Liberty Sts.,  
608 B'way,  
701 6th Ave.,  
NEW YORK

# R. WALLACE & SONS MFG. CO.

## SILVERSMITHS,

WALLINGFORD, - - - - - CONN.

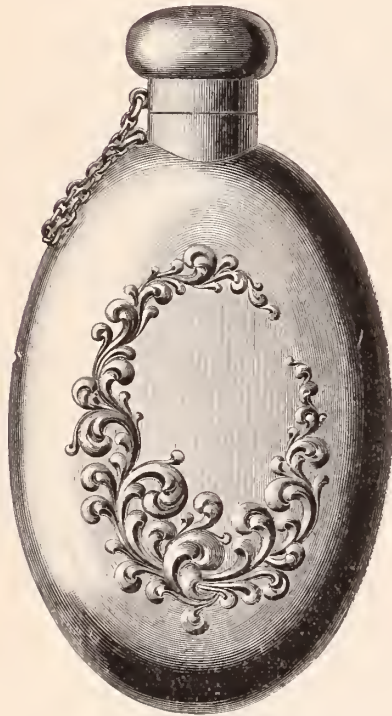

No. 20. FLASK.



No. 53. INK BOTTLE.  
CHASED TOP.

Trade Mark.

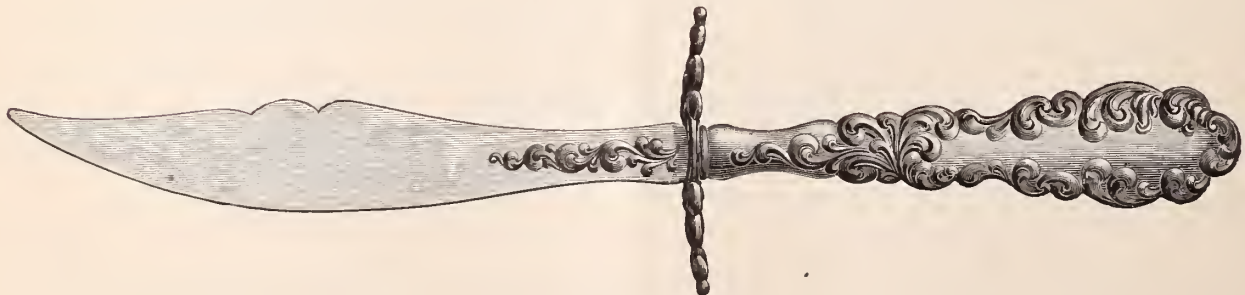

No. 39. PAPER CUTTER.

NEW YORK  
226 FIFTH AVENUE.

SAN FRANCISCO  
120 SUTTER STREET.

CHICAGO  
86 WABASH AVENUE.

# BUSINESS IN 1894, AND PROSPECTS FOR 1895.

INTERVIEWS BY THE JEWELERS' CIRCULAR'S CORRESPONDENTS WITH PROMINENT DEALERS THROUGHOUT THE COUNTRY.

*Continued from page 17, Jan. 9, 1895.*

## An Active Business in the City of Elms.

NEW HAVEN, Conn., Jan. 5, 1895.

Our New Haven jewelers report, on the whole a fairly active business for the holiday season—better than last year's; but the general verdict is that while sales were more numerous than last year they were chiefly confined to the less expensive grades of articles, and owing to this limitation the total receipts were from 25 to 30 per cent. less than those of 1892, which was a very prosperous year. The general opinion prevailing as to the outlook for the Spring trade is one of hopefulness.

Gen. George H. Ford said: "Our sales did not equal those of 1892, but the number of packages sent out was as large, perhaps, as at any previous season; and the ruling prices in nearly all classes of goods being much less than in former years, the returns fell off in volume, and owing to the same fact the returns in our class of trade will continue to be proportionately less in volume. I do not anticipate any marked improvement in business, either in our line or in the business world generally until the national currency and financial questions are settled on a solid basis. When that is accomplished I look for a return of substantial prosperity. We are confronted with a stubborn fact, not a theory. It is simply this: as a nation we are spending more than we earn. The national expenses are greater than its income. As a result the national debt is increasing through the issues of bonds to make up the deficiencies. This entails debt and increased expense in order to save the interest on the increased debt. The nation is borrowing money—working on borrowed capital. As soon as the nation gets back to a sound financial basis prosperity will return."

S. H. Kirbysaid: "Our trade this year was quite satisfactory. It did not surpass last year's, but last year's was exceptionally good with us for the reason that it was our removal sale when we closed our old store and came to our present headquarters. That removal sale gave us a very fine trade. Hence we consider that our holiday trade this year was very satisfactory. It was considerably short of that of '92, however, yet I look for an improved business in the Spring. Signs point that way. The country will emerge by and by from gloom and depression and shake itself for a new spurt."

S. Goodman & Co. said: "Our tradethis season was excellent in lines of small articles. Our sales of silver novelties were exceptionally large. The demand for expensive goods was very moderate. Our sales were more numerous than last year. The total result is a little improvement. I look for better times in the Spring."

S. Silverthau & Sons: "We found an increased demand for high priced goods over that of last year. There was less cry of hard times, hardly any in fact. Last year we heard that remark frequently. People are feeling better. Our sales fell short of the big trade of '92, but were better than '93's. We think business is picking up and will be better still later on."

Wells & Gunde: "Our sales were a little ahead of last year's. Business this holiday season was active, and the call was well distributed throughout the week owing to the continued run of favorable weather. We had a good business and have nothing to complain of and anticipate an improvement of the times by and by. No immediate boom but a gradual, slow, but sure improvement."

Edward Engel said that his holiday trade had been equal to that of 1893, but his trade was never specially great in Christmas week, but was a steady, evenly distributed all the year round trade. He was hopeful of a continued improvement in business as here in New Haven all the manufacturers were doing a big business as compared with a year ago, and times were much better.

## The Jewelers of Louisville are Enthused.

LOUISVILLE, Ky., Jan. 3, 1895.

The outlook for business is considered exceedingly bright here. For the past two months business has been far beyond all expectations, and during the few days since the holidays the trade was good, which is quite unusual. Jewelers are very much enthused, and are looking forward to the ensuing year with expectations of prosperity.

Wm. Kendrick's Sons: "Business was better than anticipated, although the first eight months were very unsatisfactory, yet in the latter part of the year from October on, business has been satisfactory. Silver goods were the life-savers of holiday trade and Fall trade was kept humming on wedding presents. Gold jewelry was very slack, as was also the watch business. Business, as a whole, was way ahead of 1893."

Irion & Girardet: "Business right good for the holidays, but on a whole do not consider business as good as '93, the first part of '94 being good. Silver novelties had their sway, but diamonds sold only medium to fair, and watches did not sell well. Gold rings sold well, otherwise gold was not in it."

C. P. Barnes & Bro.: "The sales were small and more numerous than '93, but we do not think that as a rule the many small sales will foot up as much as the larger sales of other years. Holiday business was far in excess to trade expectations. In the country the disposition to buy is good, but sales are small, yet many more than usual."

Buschemeyer & Seng: "Ninety-four has been the best season we have had since we have been in business. New work was more noticeable, showing that people were buying more new goods, and not simply having old jewelry fixed up. Business is holding up very well since Christmas, and prospects for '95 are very good."

George H. Kettmann & Co.: "1894 business very good, better than 1893 and about the same as 1892. Holiday trade better than expected."

Rodgers & Pottinger: "Business was better than anticipated. In character—not so many large sales to individuals, but many sales of less value but of more frequency. Silver had the lead; there was a demand for better watches than before; sales in diamonds quite numerous but of small value each."

Lieberman & Son: "Trade looks more encouraging. Not so many large sales were made, but small sales were easily made and were of great number."

Borgerding Bros.: "Commencing about August, trade was the best we have ever had. On the whole, trade much better than in 1893 and somewhat better than in 1892. Our sales of optical goods are increasing right along."

## Milwaukee Jewelers in a Pleasant Frame of Mind.

MILWAUKEE, Wis., Jan. 4.

Milwaukee jewelers are in a very pleasant frame of mind. The holiday trade, they all say, exceeded expectations and the prospects for a prosperous new year are undeniably bright. Small sales, but plenty of them, seem to have been the rule at all the stores. Silver novelties took the lead. There was a very fair trade in diamonds and jewelry also, as the subjoined interviews will show.

Louis Bunde, Bunde & Upmeyer: "Our trade was especially good the last four months, in fact way ahead of last year. We made three times as many sales, but they were largely small ones and our December business was almost equal to '92. The outlook for 1895 seems very bright. We sold more silver novelties than anything else, with quite a fair trade in diamonds and pearls."

The A. K. Camp Co.: "Our Christmas business was double that of 1893. From the way things look the coming year will show a steady improvement. People do not seem to hang on to their money as they did last year. We are very well satisfied with our holiday trade and can truthfully say that it was much better than we expected. We had a better trade in silverware, especially in novelties, than anything else. We had a good diamond trade the latter part of the year, too. Watches sold about as usual. We had a great deal of marking to do, so much silverware was sold."

Mr. Thatcher, O. L. Rosenkrans & Thatcher Co.: "Trade was better this year than last. There was not as much heavy buying but more sales were made. In fact, the last four or five months has shown a steady increase in general business—no boom, but a steady increase. Silver novelties, silverware, watches, diamonds and jewelry sold very well; silver novelties leading. I believe we waited on as many customers during the holidays as we ever did, although the amounts were small, as a rule. My impressions are that the people are feeling better and are not afraid to spend money nor are they apprehensive of anything to come. For the coming year trade is pretty sure to be good and to constantly improve."

The C. Preusser Jewelry Co.: "We were more than pleased with the holiday trade. The trade started early this year and was over 30 per cent. better than last year. The first six months of 1894 did not keep up with 1893, but the last six months were much ahead. Our December trade was unexpectedly large, and we look for a very good trade the present year, showing general improvement. Our trade was good in all lines and scarcely one better than another."

Julius Lando, optician: "As business could not be worse than 1893 it had to be better. I should say that the last few months of the year improved 25 per cent. As to the new year, I feel somewhat pessimistic. People are buying very close, and seem to begrudge a dealer a decent profit. Fine goods are not much in demand."

Jewelers generally throughout the city report a good holiday business. This is the case with Lord Bros., A. Bloedel, James Gilowsky and others.

## Jewelers of Columbus in High Feather.

COLUMBUS, O., Jan 5, 1895.

After a year of business which far surpassed that of 1893, ending with a surprising holiday trade, the consensus of opinion among the Columbus jewelers is that the outlook is promising for the coming year. The holiday trade began early and continued up to and including New Year's day. At several of the stores not only new clerks were engaged, but the workmen were pressed into service behind the counter.

T. T. Tress says his holiday trade exceeded his high expectations, and that everything was cleaned out and the clerks completely exhausted. He says the past year has been a successful one for the firm, showing an increase of 25 per cent. over the business of the previous year, and in consequence he will stock up heavier than ever before.

Bourquin & Co. say that business in every department of their store was so much better the past year that they have many reasons to be well satisfied. Their sales during the year were well divided among the different lines of goods. Their holiday trade was even better than that of '92. Every clock but one was disposed of.

Mr. Harrington thinks there is a better feeling prevailing among the tradesmen in general and he thinks there is every indication of a promising Spring trade.

F. F. Bonnet's store was crowded during the holi-

days. The demand was so great that every available man in the house was put to selling goods.

A. A. Gerlach says that while the past year has been better than the year before he doesn't see how it could possibly have been worse than '93. He says that while his holiday trade was good it has now dropped back again to the ordinary basis.

Barnitz & Nunemacher report an especially good business the past year in silver novelties with an absence of the usual sales in high priced goods. The general run of business was good during the year and in the holidays they had all they could handle. Their opening of Dec. 13th was an elaborate and profitable affair.

Aune & Wirschinger report the sales of diamonds and watches larger than in anything else.

J. B. White reports his first year of business as having been successful. He made a specialty of optical goods.

H. Cole expressed himself as well pleased with the holiday trade and as having had a fair optical trade the past year. He thinks the outlook for the coming year promising.

### Big Run on Silver and Bric-à-brac in Birmingham, Ala.

BIRMINGHAM, Ala., Jan. 2, 1895.

The jewelry trade in Birmingham during the past year has not been altogether satisfactory, but there has been an unprecedented run in novelties, especially silver novelties and bric-à-brac. The following are brief expressions of opinion from leading retail jewelers here:

Robert Sturges: "Trade during the past year has been rather dull, but since I have removed to my new quarters in 20th St. and enlarged my place of business it has been steadily improving. This dates from October. We look forward to better trade, and there is every indication that our expectations will be realized. Solid silver novelties and bric-à-brac have had the run altogether during the past year. Watches have been slow."

H. C. Abbott & Brother: "We had a fair trade in 1894. Our trade in cut glass and bric-à-brac was especially good though it was the first year we handled those lines of goods. Silver novelties have been in great demand. The watch trade has been dull but the outlook for that class as well as all other classes of the jewelry trade is much better, as general business conditions are greatly improved."

Harry Mercer: "General business has been anything but satisfactory. Holiday trade was shorter than that of the preceding season and was confined chiefly to cheap goods, especially novelties and bric-à-brac, which have been in fairly good demand. As to the prospects, that depends altogether on industrial conditions hereabout."

Rosenstihl Bros.: "The past year has been one of considerable depression in the jewelry trade. Trade was dull up to the holidays; then it was good, especially in the smaller lines of goods, such as novelties. High price goods have not been much in demand. The outlook is good and everybody seems to have taken in renewed hope and life. The prevailing demand now is for silver novelties, though watches and optical goods are having a fair run. Bric-à-brac is on a boom. We are encouraged at the prospects."

### The Trade in Rockford Fairly Satisfied with 1894.

ROCKFORD, Ill., Jan. 2d.

The business of the jewelers of this city the past year was on the whole satisfactory. Rockford, being a manufacturing city, the panic was felt as severely here as at almost any point. The jewelry interests naturally suffered, but the summary is that none has reason to complain. There were several new entries into the trade during the year, the majority, however, being small establishments. The holiday business was good, smaller price goods having the call, which was anticipated, and a large amount sold. None of the jewelers have any expressions to make regarding the

prospects of 1895. In interviews the leading merchants expressed themselves as follows:

J. C. Peers: "Trade was quiet during the Summer but splendid during the month of December. The holiday trade opened earlier than in the preceding year. I sold a large amount of silver novelties."

N. E. Benoit: "The year was far from being on the boom order. My holiday trade, however, was highly satisfactory, the month of December better than in the preceding year. The people bought earlier."

J. Beale & Son: "Trade during the year just closed was not at all booming. Our holiday business was very satisfactory. Watches and higher price goods did not move freely but there was a great demand for novelties."

D. F. Sullivan: "It was one of the best years I have had since I have been in business. One feature was that there were many out of town buyers. That is a good sign as it shows that people from other counties are coming here to trade."

A. E. Henry: "Business was about the same as last year. The holiday trade opened early and continued steady."

J. T. Buker: "It was a quiet year, but the holiday trade was of the right kind. Cheap goods were in demand."

### The Jewelers of Wilmington Not Altogether Satisfied.

WILMINGTON, Del., Jan. 4.

The retail jewelers of this city are well pleased with the holiday trade. The jewelers who carried only the highest class of goods fared very badly throughout the whole year, but those who carried the medium class of goods also, came out in fair shape. The holiday trade, with very few exceptions, was far in excess of the previous year. The prospects for this year are more favorable than they were at the beginning of last year.

Samuel H. Baynard says that, taking the number of people in the store through the holidays, if the prices goods would have been sold at in former years, with the exception of Christmas '93, were obtained the season would far excel former years, but the sales were all for small goods.

Harry E. Thomas, of H. E. Thomas & Co., says that the holiday trade was equal to the holiday trade of '92.

### Bangor Jewelers Report Generally Good Trade.

BANGOR, Me., Jan. 2, 1895.

Nearly every dealer in this city in jewelry, silverware, etc., reports his business for 1894 much better than the preceding year. This was so especially with the Christmas trade. One dealer was able to lift a mortgage of \$2,000 upon his stock and is greatly pleased with his business for the past year.

W. O. Colomy said that he had a fair year. He has only been in the jewelry business two years and was therefore unable to compare his business this year with those preceding it. He said that his best trade has been in solid silverware, of which he carries a large stock. He says that he believes that the coming year will be a good one with all branches of the jewelers' business.

W. C. Bryant said that his Christmas trade in 1894 was one-third larger than in 1893. He did a big business in sterling silverware. Some jewelry was sold and the trade in watches was fair. Mr. Bryant thinks that his business in 1895 will be the best yet. He has been in this city only two years and is greatly pleased with what he has done in that time.

Bernhard Pol, who is one of the oldest men in the business in the city, said that his business as a whole was not so good as in 1893. His Christmas trade was better than in the preceding year. He sold more watches this year than last, and he also had a good trade in sterling silverware. He hoped that 1895 would show an improvement in all kinds of trade.

W. H. Blacar said that the dull times of 1893 nearly everybody complained of did not affect his

business in the least. Mr. Blacar says that everything points to a most successful business for 1895. He believes that if the lotteries could be stopped that every jewelry dealer would have a better trade in the watch line. Mr. Blacar thinks that his Christmas trade was as good as in 1893.

The Tebbets Jewelry Co. have had their store open but a few months, but during that time their business has been very good. They carry a small stock but what they have is of the finest quality.

W. H. Edmunds and Adolf Pfaff report a good year's business in all lines of trade. The former makes a specialty of badges and he has had a big trade in this particular line during the year.

### Generally Satisfactory Feeling in Davenport, Ia.

DAVENPORT, Ia., Jan. 2.

Davenport jewelers are not buying large blocks of railroad stocks with the profits of their 1894 business, nor have they offered to help Secretary Carlisle out of his difficulty by keeping the gold reserve up to high water mark. I have only found one firm, however, whose members were disposed to write when asked as to the business done during the past year. Others who are not decidedly happy express themselves as satisfied with the share of trade that came their way, especially when compared with the previous year. Here are some of the expressions:

T. Kirchner: "The year as a whole was not satisfactory, although December business was a pleasant surprise. We feel a good deal better now than we did a year ago, and the outlook for 1895 is really hopeful. Trade has held up splendidly since Christmas. Silver novelties were the feature of the holiday trade, but solid silver and jewelry went well, while watches were slow. The demand for opera glasses surprised us and exhausted our stock. Our optical business has been good throughout the year."

M. E. Nabstedt: "Since we moved into our present quarters July 1st, and added to our shop facilities, our wholesale business has greatly increased. Our retail business has also been growing, and in 13 years we have never done the December business that we did this year. The demand began to increase in November and kept growing right along. Improved location had something to do with it. The watch trade was not so large as last year, but there was a good diamond sale and a good demand for clocks and large pieces."

Stark & Ruser: "Haven't figured up yet and don't know whether we are ahead or behind. Haven't any prospects—can't look into the future. Nothing to say. Those eastern papers want our figuring for the manufacturers, and can't have them. Manufacturers are making all the money; we can't make none."

A. C. Billon: "Our December business was double that of last year but October and November were very poor. It has been a poor year for repairing too. Next year will be as good or better than this—it can't be worse—so we are not in despair. For our first complete year here we are pretty well satisfied."

### Buffalo Jewelers had a Better Trade in 1894 than in 1893.

BUFFALO, N. Y., Jan 4, 1895.

According to all reports the jewelry business in December was better than that of the last few years. The goods sold were not as expensive as in other years, but the quantity was much larger. Silver novelties sold the best. Diamonds and other jewelry sold very well, but watches, as a general rule, went slow. Jewelers report that had general trade during the year been equal on the average with the holiday trade, the year of 1894 would have been a big year for them.

Heintz Bros. say their business of 1894 will average about the same as 1893, but the month of December will run away ahead of the corresponding month of last year.

Ansteth & Reinsch: "We are working on our books now, but think the business of the year will be fully as good as last year. The outlook for the coming year is very good. Business ought to be very much better, because the retailers bought light last



year and all report a big holiday business."

King & Eisele report business for October and November ahead of last year and December as good as 1892. The reports from different parts of the country received so far speak well of business, and collections are very good.

Frank Hammond reports business for the year about the same as last.

C. Bushman reports business decidedly better than last year. It was all in smaller articles.

C. Pchellas reports business for the year not as good as last year, but December was far better than the same month last year.

T. & E. Dickinson report business ahead of 1893, and the outlook so far for 1895 bright. Sales did not run in any particular line. Sold just as many high priced goods as before.

J. H. Ullenbruch reports business better than 1893. Watches sold better than in 1893.

C. C. Penfold's business was much better than 1893 in general lines.

W. A. Wanda's business was just about as good as in 1892, which was one of the largest years he ever had. Silver novelties, small diamond goods, and, in fact, a general line except clocks sold.

T. C. Tanke reports much better business than in 1893. More diamonds than watches were sold. It was a big year for silver goods and bric-à-brac.

F. W. Juengling had as good business as in 1893 - mostly in lower priced goods. Some diamonds and watches were sold, but not as many as in 1893.

C. F. Chouffet: "Better than we ever did before; mostly in small articles, especially silver novelties and other goods ranging in price from \$5 to \$10. Few gold watches and large diamonds were sold."

J. Clegg did better than in 1893. Watches sold well, but silver and gold novelties sold more than staple goods.

C. A. Kuster: "Much better than in 1893. Cheap watches sold very well."

A. Jiliox: "Am perfectly satisfied. It was much better than last year—almost as good as 1892."

### Hopeful Feeling Among the Jewelers of Boston.

BOSTON, Mass., Jan. 5.

Boston jobbers and retailers are agreed upon one point, namely, that the holiday trade of the past month was very good compared with that of the corresponding period in 1893, and many of them will go even farther and assert that it was entirely satisfactory, inasmuch as it exceeded their expectations. Of the early portion of the year little can be said beyond the repetition of what was so painfully impressed upon the trade from week to week. It was dull, and the dullness continued monotonously through six months at least before there was any tangible improvement in trade conditions. The change for the better made good progress after it had attained a little headway, however, and in the Fall and holiday seasons there was fully 25 per cent. gain upon the whole, with a much more cheerful tone pervading all lines. As the Boston dealers are in the habit of deferring their stocktaking till February, it is impossible for them to give any definite estimates of the year's results for a month or more, but they feel justified in hoping for a better business in 1895 than they had last year. It is evident, too, from the following interviews that the jobbers base their hopefulness upon the more encouraging sentiment that they discover among their customers in all parts of New England.

D. C. Percival: "The first half of 1894 was like the last half of 1893, rather discouraging, but business improved very substantially, as the holidays approached, and the closing months of the year were quite the reverse of the opening ones. The outlook is more promising now than it was a year ago."

Harwood Bros.: "Business isn't as bad as it was at the beginning of 1894 and we are hopeful. Retailers don't buy as freely as they formerly did, but there is a distinct gain in the volume of trade and a healthier tone. There is more disposition to stock up in staple lines. The watch trade has suffered as much as any during the past year, purchases in this line being less,

proportionately, than in diamonds and various classes of jewelry."

Morrill Bros. Co.: "The results that count with us are the profits. In volume, business has been all that could be wished for during the past year, but the margin between cost and selling price has been slight. That is the unsatisfactory feature of trade at present. From all indications this method of doing business will not be modified much during the year before us, and to the extent that it prevails the business of 1895 will be disappointing. Business depression makes competition keen and those who secure the business obtainable frequently have to bid pretty closely for it."

E. B. Floyd & Co.: "The year just closed is hard to summarize. It ran to both extremes. The first half was very unsatisfactory and the last half was just as pronounced the other way. Fall and holiday trade was excellent. Changes in the lines of stock that were found to be most salable were quite as much a matter of fashion as anything. There was a noticeable falling off in the trade of watches and the more expensive jewelry, and a marked increase in the demand for sterling silver goods, which are the fad to some extent now. The present outlook is very encouraging at all points."

E. A. Whitney Co.: "Trade has been quiet until within a few months, but the outlook is brighter now. The holiday novelty trade was especially good."

Smith & Patterson: "We are inclined to believe that our totals for the year, which will be footed up in a day or two, will show a greater volume of business transacted last year than in 1893. The past three or four months have been more than lively, and, even since Christmas, trade has continued good. We hear from most of our customers throughout the New England States that their Christmas trade was excellent, and, as a general rule, there was a bouncing big holiday trade all over this section. This being the case, stocks are low and will need replenishing. We look, therefore, for a very good business in the near future. The relative cheapness of solid silver lately has started up buying in that direction, and silver novelties as well as table ware have had a remarkable good sale. Diamonds have been a good investment, too, and there has been a fair movement in that line. The watch trade has not been so brisk as in previous years, however."

George H. Richards, Jr. & Co.: "The business of 1894 was poor as a rule, but it wound up with a good holiday spurt. Christmas trade was excellent—ladies' watches, silver novelties and diamond jewelry selling readily. As for the outlook this year—well, it's rather early to prophesy, but everybody seems to be more hopeful and that ought to help matters along considerably."

Charles May: "Business in the material line has not been as profitable as in the years immediately preceding the financial depression. In my opinion there will be no boom in 1895, but I look for a better year on the whole, and believe that the prevailing sentiment is strongly that way. Business has been going, of late, very much like a door with one of its hinges broken. Repair our monetary conditions and things will swing all right again."

Henry Cowan: "We have had a good trade ever since September, and some of the time were so busy that we all had to work late after regular hours. Reports from our customers show that trade generally in December was very good. Boston retailers, on account of the fine weather just before Christmas, drew away from suburban jewelers some of the trade that usually goes to the local dealers in such places when weather conditions are such as to discourage people from making the trip to Boston to do their holiday buying. The class of goods most in favor has been the medium grade. Stores catering for trade in this line have been able to secure the most custom as a rule. The higher grade stores have the least cause to be pleased with the year's results."

George H. Whitford & Co.: "The past year's trade has been mostly in silver ware and silver novelties. I don't think our regular line of flatware has gone any more freely, but the novelties of the year, which have been very attractive, sold better than anything else. Watches have been dull. The Christmas trade was fully as good as we expected, and I think that was the case with almost all the retailers. Dealers

feel very much more encouraged about the prospects for the year ahead of them than they did a year ago."

George H. Lloyd: "Business in the optical line has been very satisfactory as far as my own trade can be considered any indication of the condition of affairs during the year. It was way ahead of the previous year and I look forward to even better business for 1895."

Nelson H. Brown: "In the clock line the trade outlook seems better than it has been before for nearly two years. For some months a gradual improvement has been apparent, and 1895 starts off very well. There is a good inquiry and orders are beginning to come along encouragingly."

Shreve, Crump & Low Co.: "The year's aggregate probably has been smaller than that of 1893. Trade was slow early in the year, but in the latter part was much more satisfactory. Our diamond trade was good, but aside from that high priced goods sold more slowly than usual. As for the outlook, we stand just about where we stood a year ago. We are hopeful, but realize that recovery from business crises is a slow process and do not expect too much in a short space of time."

### The Jewelers of St. Joe Very Hopeful.

ST. JOSEPH, Mo., Jan. 2.

From the tone of the report from local jewelers and the smile on their faces, we should infer that the volume of 1894's business, especially the month of December, greatly increased over that of 1893. Almost all of our jewelers are under the impression that the year of 1895 will be a prosperous one and will give more comfort to the jewelers than did the past two years. December made the wall cases and other cases quite empty in the jewelry stores, and a good new stock will be necessary in nearly every store in the city. The following are the expressions of some of our leading jewelers on the past year's business:

Mr. Hartwell, of J. F. Hartwell & Co.: "1894's business was good, in fact we have doubled our business of 1893. Our holiday trade was very good. We had more than we cared for. Should we have had ten more men for the Saturday and Monday before Christmas trade would have kept them all busy. I have good reasons to believe that the coming year of 1895 will be a prosperous one and the jewelry business will be very profitable."

August Wetteroth: "I have this much to say, that business has been so dissolved all the year around that the holiday trade was a surprise to me and entirely unexpected. It seems to me that people have spent more money for jewelry this year than in any year I can remember. In all, business has been satisfactory and I fully hope that the year of 1895 will be a prosperous one."

R. U. Hendrick: "Well! We had a good holiday trade, as much as we could expect. As far as the prospects for next year are concerned, I hope it will be very good."

L. Burnett, of Louis Burnett & Co.: "The year of 1894 was far better than the previous one. Our optical business has been a success all the year round. The month of December was unusually good. We had as much to do as we possibly could, in fact, we have done more business this month than we looked for. Our branches at Severance and Everest, Kansas, have been more than doubled of last year, and we fully believe the year of 1895 will be a more successful one than we ever had, as the farmers are all well supplied with all they need and are more liberal than they have been for a number of years. They are spending more money for luxuries and are complaining less of the prices than usual."

Albrecht & Huber: "Trade this year was just about as last year. Holiday business was fair. Had we a better location we could have done more business this holiday. We are too far down and could not expect much."

Mr. McKelvey: "I cannot tell very much about past year's business as I have not taken invoice yet. I think it was fairly profitable. Holiday trade was very good."

W. F. Kirkpatrick: "Business with us this year has been a great deal better than the year previous

Our holiday trade was very satisfactory. As far as prospects for next year I am unable to say."

W. L. Dendover & Co.: "Trade this year was a great deal better than last year. Collections very good. Had a better holiday trade than we have ever had before. Everything looks bright and prosperous for next year. The poor people in St. Joseph have more money than in 1893 and a good part of it will be spent with the jewelers."

R. T. Levin: "Business this year was good; far better than last year. Holiday trade was beyond expectation."

Henry Elbelt: "I cannot express very much in regard to this year's business, as I have not taken stock yet. Holiday trade was fair, in fact good considering hard times. Prospects for next year I hope will be good."

R. L. Weber: "Trade this year was fair. Holiday business was quite good, better than last year."

Mr. Roy, of Regnier & Shoup Crocker Co.: "Never before in the history of our business in St. Joseph have we done a better business than we have done this year."

(To be continued.)

**Mrs. Sarah M. Feiga Files a Petition in Insolvency.**

WORCESTER, Mass., Jan. 10.—Sarah M. Feiga, dealer in jewelry, 270 Main St., wife of Max Feiga, through her counsel, Tues-

day, filed a voluntary petition in insolvency. Judge Forbes issued a warrant against the debtor's estate, returnable Friday, Jan. 25, when the first meeting of the creditors will be held. Deputy sheriff D. H. Hayter is in charge of the property as messenger. The property in the store, which was attached a short time ago by deputy sheriff James Early, at the instance of Johnson & Gillespie, Boston, for \$1,000, has been removed by the attaching officer, and is stored in the Worcester Storage Co.'s place.

The store was attached Jan. 1, at the instance of Johnson & Gillespie, and a keeper placed in charge. The case was one of contract and the writ is returnable in the Central District Court. Mrs. Feiga had taken out a married woman's certificate and did business in her own name. On Dec. 24, it is alleged, she mortgaged the store to Barnett Wolkowich, for \$850, and the attaching creditors claim that this was done for the purpose of defrauding her creditors. Several of the creditors formed a combination to contest the validity of the mortgage and they intended to make an attempt to annul it if possible. It was after this movement and the attachment that Mrs. Feiga filed the voluntary petition in insolvency.

**DIAMONDS.**

**Wm. S. Hedges & Co.,**

**Importers of Diamonds,**

And Manufacturers of DIAMOND JEWELRY.

**170 Broadway, New York.**

22 Holborn Viaduct, London.

**Alfred H. Smith & Co.,**

IMPORTERS

**DIAMONDS**

AND

PRECIOUS STONES,

**182 BROADWAY, COR. JOHN STREET,**

**NEW YORK.**

83 Holborn Viaduct. London. E. C.

**R. A. KIPLING,**

**Precious Stones**

AND **Fancy Goods**

**Bought and Sold on Commission.**

**19 RUE DROUOT,**

**PARIS, FRANCE.**

**ONE YEAR'S SUBSCRIPTION**

—TO—

**The Jewelers' Circular,**

—At \$2.50,—

Entitles the subscriber to a copy of "WORKSHOP NOTES" free, a 200 page book, bound in cloth, containing a fund of information for the workshop that can be found in no other work.

**A Swindler Cleverly Works Upon Pittsburgh Jewelers.**

PITTSBURGH, Pa., Jan. 8.—A young man under the name of Simon Stern, worked the bogus check game and a half dozen jewelry and other firms are the losers. He came to the city on Dec. 28th, and took up his quarters at the Monongahela House. The next day he visited a number of jewelry stores and ordered sets and pieces of silverware amounting from \$17 to \$38. The purchases, he said, were birthday gifts for Mrs. Samuel Wertheimer, wife of the well-known distiller, and were to be sent to her home on Western Ave., Allegheny, some day during the following week. Elaborate monograms and initials were to be engraved.

Payment was tendered in the shape of a check for from \$8 to \$12 more than the price of the purchase. All the checks bore the name of Samuel Wertheimer and were payable to Simon Stern at the Duquesne National Bank. The checks were accepted by the dealers and the change paid to the young man. The jewelers selling the goods and the amounts for which they were "done" are: E. P. Roberts & Sons, \$16; G. W. Biggs & Co., \$10; R. Siedle & Sons, \$13; B. E. Arons, \$10; Sheaffer & Lloyd, \$10; When the goods were sent to Mr. Wertheimer, he promptly returned them saying he had not ordered them. At the same time, the checks commenced coming back from the bank marked "no account."

They were all forgeries. Four were for \$50 each and two for \$25 each. Last Wednesday the police commenced receiving complaints from the merchants. A search was made for the young man, but he had left the hotel on New Year's Day.

**OPPENHEIMER BROS. & VEITH,**

**35 MAIDEN LANE, - NEW YORK.**

CUTTERS OF

DEALERS IN

**DIAMONDS, WATCHES.**

**HAMPDEN MOVEMENT, DUEBER CASES A SPECIALTY.**

**Important Measures Before the Missouri Legislature.**

The following circular letter was received by THE CIRCULAR from the National Retail Jewelers' Association of Missouri :

DEAR SIR—We beg to call your attention to the enclosed copies of bills that this association will introduce in the present session of our Legislature and Senate.

A careful scrutiny of these upon your part will no doubt convince you that these messages are of vital importance to the jewelry trade.

To secure their passage and have them become a law of the State we would call upon you to communicate with the members of the Legislature and Senate of your district ; advising and informing them of the true and actual value of such laws to the jewelry trade and the general public.

The bill dealing with the stamping of silver is modeled after the law in force in several of the eastern States and is indorsed by all honest manufacturers and dealers, as it will prevent and abolish the fraudulent advertising and sale of white metal, pewter and silver plated goods as "sterling" or "coin silver."

The bill relative to auctioneers and auction sales will meet with the strongest opposition that can be brought against it by the auctioneers; it being to their interest to defeat the measure as these auction sales are only successful in the evening, when the legitimate business houses have closed. Already we are in receipt of information that strenuous efforts are being made to fight this bill, consequently prompt action upon the part of the jewelry trade is necessary; therefore we beg you to consider this matter carefully and ask for your co-operation.

Very truly yours,

RETAIL JEWELERS' ASSOCIATION OF MISSOURI.  
W. S. Kemper, Sec'y

The bill dealing with the stamping of silver is that drafted by THE JEWELERS' CIRCULAR, and placed in the hands of Senator R. D. Lancaster, of Missouri, by the Mermod & Jaccard Jewelry Co., as stated in a communication from that firm, published in the last issue of THE CIRCULAR. The measure treating of auctioneers, etc., is as follows :

**AUCTIONEERS: SALES AT NIGHT.**

AN ACT to amend Chapter 14 of the Revised Statutes of the State of Missouri of 1889, entitled "Auctioneers," by adding therein a new section to be known as section 687 a to prohibit the sale at night by auction of certain classes of goods.

SECTION 1. To prohibit the sale at night by auction of certain classes of goods. Be it enacted by the General Assembly of the State of Missouri, as follows:

SECTION 1. Chapter 14 of the Revised Statutes of the State of Missouri, entitled "Auctioneers," is hereby amended by adding thereto and therein a new section, to be known as section 687 a, as follows:

SECTION 687 A. Except in cases wherein the property sold shall be free of duty, no person shall at public auction in the night time between sunset and sunrise sell any table wares of metallic manufacture or any precious stones, common gems or pastes or any article of personal ornament ordinarily known as jewelry or imitation jewelry or any articles of personal convenience or apparel carried in use about the body and being in whole or in part of metallic or mineral manufacture.

M. Schulze, Mansfield, O., who has been doing business in the Wilerhouse block at 59 N. Main St., for many years, has made an assignment to Howard B. Dirlam. The assets are about \$5,500 and the liabilities, consisting of real estate and personal property, are estimated at about the same figure. The assignee furnished bond in the sum of \$11,000.

ESTABLISHED 50 YEARS.

LANDEL, BAREMORE & BILLINGS,

IMPORTERS OF

DIAMONDS,

AND OTHER PRECIOUS STONES.

FINE PEARLS A SPECIALTY.

MANUFACTURERS OF

DIAMOND JEWELRY,

IN THE LATEST DESIGNS.

Diamonds Recut in Modern Styles or Repaired on Premises.

58 Nassau Street,  
29 Maiden Lane,  
NEW YORK.

1 Tulp Straat,  
AMSTERDAM.

1 St. Andrews St.,  
Holborn Circus,  
LONDON, E. C.



TRADE MARK.

ESTABLISHED 1841.

CARTER, SLOAN & CO.,

MANUFACTURERS OF GOLD JEWELRY,

No. 15 MAIDEN LANE,

NEW YORK.

A. CARTER JR.  
A. K. SLOAN.  
C. E. HASTINGS.

GEO. R. HOWE  
WM. T. CARTER  
WM. T. GOUGH.

FACTORY, NEWARK, N. J.



JOHN N. DISSÉLKOEN,

Gutter and Importer of

DIAMONDS

FACTORY  
76 LANGEBLEEKSPAD  
AMSTERDAM.

19 East 16th St.,  
NEW YORK.



## Death of Aaron L. Dennison.

The death of Aaron L. Dennison, "the father of the American watchmaking industry," was announced in New York by the following cablegram received Thursday at the office of the American Waltham Watch Co., 21 Maiden Lane:

"Father died last night.

EDWARD DENNISON."

The recipient of the telegram, Alfred Bedford, manager of the English branch of the American Waltham Watch Co., now in New York, stated to a CIRCULAR reporter Friday that Mr. Dennison's death was undoubtedly due to Bright's disease. When Mr. Bedford left England about a month ago Mr. Dennison had been suffering from this complaint for two months. Prior to that time, he had been apparently in the best of health, and showed no signs of illness. Only last year Mr. Dennison, though 82 years old, took a trip to Italy and visited his married daughter at St. Remo.

It is by reason of Mr. Dennison's early conception, the interchangeable system applied to watchmaking, that to-day, a watchmaker need be possessed of only ordinary mechanical skill and intelligence to repair any watch of American manufacture. The system was first applied to watchmaking by Mr. Dennison in 1850.

Aaron L. Dennison was born in 1812 in Freeport, Me., the son of a shoemaker. In 1822 we find him carrying a mason's hod in the village of Topsham. In 1825 he was making his own living as a lad of 13 years of age, by sawing wood in Brunswick, to which place his father moved in 1824. Two years later he was working at his father's trade, at which he continued till his 18th year when he grew tired of cobbling. His was a mind filled with mechanical ideas, turned mainly in the direction of watchmaking and kindred work. His father recognizing this, in 1830, apprenticed young Aaron to James Carey, a watchmaker of Brunswick. In 1833 Aaron left this town, entering the employ of Currier & Trot, of Boston, to perfect himself as a journeyman watchmaker. He shortly engaged in business for himself, but at the end of a brief time, we find him in the employ of Jones, Low & Ball, where he made the acquaintance of Tubal Hone, considered at that time one of the most expert watchmakers in the country.

It was while in the employ of Jones, Low & Ball, that Mr. Dennison, in 1835, was convinced that the workmanship and construction of even the best hand made watches of the period were full of inaccuracies, as may be inferred from a letter

written at this time, of which the following is a copy: "Within a year I have examined watches made by a man whose reputation at this moment is far beyond that of any other watchmaker in London, and have found in them such workmanship as I should blush to have it supposed had

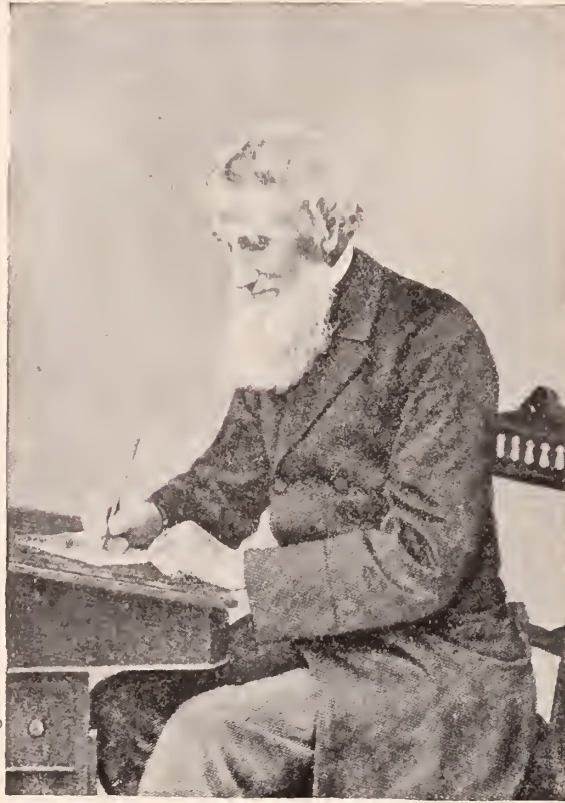

THE LATE AARON L. DENNISON,  
"THE FATHER OF THE AMERICAN WATCHMAKING INDUSTRY."

passed from under my hands in our lower grade of work. Of course I do not mean to say that there is not work in these watches of the highest grade possible to carry the finisher's art, but errors do creep in and are allowed to pass the hands of competent examiners, and it needs but slight acquaintance with our art to discover that the lower grade of foreign watches are hardly as mechanically correct in their construction as a common wheelbarrow."

In 1839 after a brief residence in New York, we find Mr. Dennison in business for himself in Boston, repairing for the trade and carrying a line of tools and materials. He built up quite a large trade and soon handled watches and jewelry. About this time he invented the Dennison Standard Gauge, and was in deep thought upon the subject of manufacturing watches on what is now known as the interchangeable system. The following extract from an address delivered before the Society of Arts, London, May 19, 1886, by Prof. Leonard Waldo, is in Mr. Dennison's own words: "The principal thinking up of the matter was done when I was in business at the corner of Bromfield and Washington Sts., Boston, and many a night after I had done a good day's work at the store and a good evening's work at home in repairing

watches for personal friends, I used to stroll out upon the Common and give my mind full play upon this project; and now, as far as I can recollect what my plans then were as to the system and methods to be employed, they were identical with those in existence at the principal watch factories at the present time." In 1846 he predicted that within twenty years the manufacture of watches would be reduced to as much system, perfection and expedition as obtained in the manufacture of fire-arms in the United States armory, in Springfield, Mass., which he often visited and where he evinced great interest in examining the various processes of finishing fire-arms.

In 1849 Edward Howard, a clock and scale maker of Boston, and founder of the E. Howard Watch & Clock Co., argued with Mr. Dennison upon the advantages of engaging in the manufacture of locomotives, but Mr. Dennison convinced Mr. Howard that the manufacture of watches in large quantities, on the interchangeable system would prove a profitable undertaking. Together they went in search of a capitalist, whom they found in the person of Samuel Curtis, of Boston, who furnished \$20,000, with which to try the experiment. D. P. Davis, Mr. Howard's partner, was also interested in the enterprise. The first money spent was for a tour of observation in the watchmaking districts of England, with a view

of ascertaining whether watchmaking was carried on there on the system represented to Mr. Dennison by English workmen he had employed from time to time in repairing; also with a view of finding out the source of supply for the necessary materials.

While Mr. Dennison was in Europe, Mr. Howard engaged in erecting a factory, and on Mr. Dennison's return work was immediately commenced. The results of Mr. Dennison's observations in Europe were summed up in a letter from which the following is copied:

"I found that the matter had been correctly represented, but in carrying out their system one-half the truth had not been told. How that the party setting up as a manufacturer of watches bought his Lancashire movements—a conglomeration of rough materials—and gave them out to A, B, C and D to have them finished; and how A, B, C and D gave out the different jobs of pivoting certain wheels of the train to certain other parts to F, and the fusee cutting to G. Dial making, jeweling, gilding, motioning, etc., to others, down almost the entire length of the alphabet, and how that, taking these various parts of work to outside workpeople, who, if sober enough to be at their places, were likely to be engaged

on some one's work who had been ahead of them, and how, under such circumstances, he would take the occasion to drop into a 'pub' to drink and gossip, and, perhaps unfit himself for work the remainder of the day. Finding things in this condition a matter of course, my theory of Americans' not finding any difficulty in competing with the English, especially if the interchangeable system and manufacturing in large quantities was adopted, may be accepted as reasonable."

The factory started in complete shape in 1851, the firm name being The American Horologe Co. The factory was located in Roxbury. In 1849 Mr. Dennison had commenced to build machinery for the manufacture of watches on the proposed system, and in 1850 he completed the model for the first watch which corresponded with the full plate 18-size of to-day. This watch was made to run eight days, but proved a failure, and its place was filled with a one-day watch. In 1853 the first watches were placed upon the market, and the name of the concern was changed to the Warren Mfg. Co., which was soon changed to Boston Watch Co. These watches were 18-size, full plate, slow train, and were sold for \$40.

In 1853 Mr. Dennison became dissatisfied with the location of the factory, and the Bemis farm in Waltham was acquired by the Waltham Improvement Co., incorporated with a capital of \$100,000, in which the Boston Watch Co. owned 30 shares of \$100 each. The building for the watch factory was started at once and was ready for occupancy Oct. 5, 1854. This was the nucleus of the present extensive factory of the American Waltham Watch Co.

The Boston Watch Co. was not a financial success and assigned in 1857, the property being purchased by Royal E. Robbins for \$56,000. After this Mr. Dennison was employed by his successors as superintendent, filling that position until December, 1861. In 1864 he interested A. O. Bigelow, one of the founders of Bigelow, Kennard & Co., Boston, in a new factory, conducted under the name of the Tremont Watch Co. Owing to the high price of labor at this time and other conditions, Mr. Dennison reasoned that it would be better to have certain portions of the movements made in Switzerland, and accordingly he went to Europe and decided that Zurich was the best location. He here gathered the necessary material together, set up the trains and sent them to Boston. Everything went along well until 1866, when the directors of the company decided to build a new factory in Boston, Mass., and make the entire watch there. This new idea was not approved of by Mr. Dennison, and accordingly he withdrew from the company. He remained in Switzerland until 1870, having taken a contract to furnish certain material for the company, which was now known as the Melrose Watch Co., and whose factory was in Melrose. The company having failed, he returned to America and tried to revive it

with new capital. Failing in this, he soon went to England, where he interested capitalists who purchased the plant and opened a factory. This concern known as the English Watch Co. is still running, though Mr. Dennison is in no way connected with it. It is run on a combination of English and American principles, with the machinery formerly used by the Tremont Watch Co.

When the American Waltham Watch Co. opened their London branch, in 1875, Mr. Dennison started manufacturing watch cases, principally for the product of this company, and became associated with a Mr. Wigley, an English case maker. The factory which Dennison, Wigley & Co. then established in Birmingham is to-day one of the largest in England. For the past three years Mr. Dennison has taken no active part in the work of this concern.

Though a resident of England for the past twenty years, Mr. Dennison up to the day of his death, was in every way a typical American. His appearance, manner, style of dress and strong New England features stamped him unmistakably as a "down east Yankee." He was tall of stature, of a genial disposition and had a personal magnetism which drew to him hosts of friends from all over the world.

The clear and keen judgment for which he was noted, he retained until his death.

The deceased was a brother of the founder of the Dennison Mfg. Co., and his nephews now carry on this business. He leaves a widow, two sons and two daughters, one son being a partner in Dennison, Wigley & Co., while the other is with the American Waltham Watch Co., at their London branch. A daughter is married to Dr. Terry, an American, who is noted as the greatest dentist in Italy.

In an article on the History of Early Watchmaking in America by E. A. Marsh, master mechanic of the American Waltham Watch Co.'s factory, this gentleman credits Mr. Dennison with being "the projector of an enterprise of systematic watchmaking, which has become an industry of no small proportions in America." Thus Aaron L. Dennison has been generally accredited with being the founder of watchmaking as it exists to-day in America, and the title that has been applied to him "the father of the American watchmaking industry" was fully warranted. Though he was the inventor of many details of machinery and improvements in watches, his place in the history of watchmaking will be the first among projectors and organizers. He showed the way, and an industry of which America is justly proud is the result of his convictions.

In the furnishing of the two new American steamships, *St. Louis* and *St. Paul*, with silverware, the Holmes & Edwards Silver Co., as reported last week, were successful in securing the contract for the flatware, while the Gorham Mfg. Co. will supply all the hollow ware.

#### J. W. Meacham Retires From His Position With the Meriden Britannia Co.

CHICAGO, Ill., Jan. 12.—After having been connected with the Meriden Britannia Co. in this city for almost 18 years, J. W. Meacham has decided to retire from his position as director of credits, and has accepted a position with the Rockford Silver Plate Co., at Rockford. Mr. Meacham's resignation will be a complete surprise in the jobbing circles, as well as to the jewelers throughout the country. He has been so long identified with the Meriden Britannia Co. in the building up of their western business in which he has had so great a share, that the Meriden Britannia Co. and Mr. Meacham have become to some almost identical.

Mr. Meacham began life as paymaster in the United States navy during the Rebellion, which position he held until the close of the war. He then engaged in the produce commission business in Milwaukee as a member of the well known firm of Morehouse, Meacham & Co. In 1878 he retired from the firm and identified himself with the Meriden Britannia Co. Mr. Meacham is president of the National Cutlery Co., of Rockford, and as stated above, will also be interested in the Rockford Silver Plate Co. He speaks in the highest terms of his association with A. L. Sercomb and of the Meriden Britannia Co., and says the change is not the result of any difference between himself and the company or Mr. Sercomb, but simply a desire to engage in a business less confining. He says he will be associated with his old friend, Geo. B. Kelley, who is secretary and treasurer of the Rockford Silver Plate Co. and also of the National Cutlery Co. Mr. Sercomb regrets very much the leaving of Mr. Meacham, as it severs an association of the pleasantest nature, and business relations that have existed since 1878.

#### Proceedings of the Jewelers' Security Alliance.

The regular monthly meeting of the executive committee of the Jewelers' Security Alliance was held at the Alliance office on Friday, the 11th inst. There were present: H. H. Butts, chairman; A. K. Sloan, president; Bernard Karsch, treasurer; Messrs. White, Kroeber, Abbott, and George H. Hodenpyl, secretary.

The following were admitted to membership: E. M. Bracher, 68 and 70 Nassau St., New York; Louis Bronenkaut, Brenham, Tex.; L. R. Erhard, Bastrop, Tex.; F. B. Harris, 1123 Ohio St., Lincoln, Neb.; N. Kaiser & Co., 15 Decatur St., Atlanta, Ga.; J. F. Lewis, North East, Pa.; C. Mauthe, 308½ Sixth Ave., Des Moines, Ia.; Louis Mandelstam, Summit, N. J.; F. E. Peckham & Co., Branford, Conn.; John Tansley, 5335 Main St., Germantown, Pa.; Albert Zilliox, 413 William St., Buffalo, N. Y.; Joseph Maier, 433 Manhattan Ave., Brooklyn, E. D.

### Cincinnati Wholesale Jewelers Address the Manufacturers.

CINCINNATI, O., Jan. 14.—The following is a copy of a circular letter that the Cincinnati Wholesale Jewelers' Association intend to send the manufacturers:

At the annual meeting of Wholesale Jewelers' Association held Jan. 24, 1895, a committee was appointed to draft a circular letter to the manufacturers of jewelry who solicit the jobbing trade, asking their co-operation in confining their sales to the legitimate wholesale jobbers, who report the following:

"It is the sense of this association, inasmuch as the jobber is the natural and legitimate distributor for the manufacturer, we believe it to be our mutual interest that a line should be drawn between those manufacturers who sell the retailer. If this movement meets the favor of your approval you will please signify the same by sending a reply to our secretary.

Address."

### J. W. Rexford Drops Dead in His Store.

SCRANTON, Pa., Jan. 9.—J. W. Rexford, of the firm of Rexford & Co., jewelers, 213 Lackawanna Ave., dropped dead in his store at 9 o'clock Monday morning. He was aged 64 years.

The body was removed yesterday to Hamilton, N. Y., for interment.

### Final Decision in the Suit over the Watch Insulator.

By the decision handed down Wednesday by the United States Circuit Court of Appeals, the Wilmot & Hobbs Mfg. Co., Bridgeport, Conn., have won the suit fought against them by the Newark Watch Case Material Co., for infringement of a patent for watch protectors. The patent covered a sheet iron case made in two parts and used to protect watches against magnetism when worn near dynamos.

The case was first argued before Judge Townsend, in the U. S. Circuit Court at New Haven, in November, 1893. The Circuit Court dismissed the bill of complaint and held the patent invalid for want of originality. The complainant company at once took an appeal to the United States Circuit Court of Appeals sitting at New York. The case was argued before Judges Wallace, Lacombe and Shipman last November. The opinion handed down by Court of Appeals affirms the decision of the Circuit Court, dismissing the bill of complaint.

### The Rogers Silver Plate Co. Awarded \$4,500 in a Suit.

MERIDEN, Conn., Jan. 11.—Meriden people have been greatly interested in the suit of the Rogers Silver Plate Co., Danbury, of which N. Burton Rogers is president, against Jennings Bros., Bridgeport, for breach of contract and \$5,000.

The trial occupied 21 days and has been in the courts a year and a half. Ex-Judge Park yesterday rendered his decision as referee in favor of the Rogers Silver Plate Co. Jennings Bros. were agents of the Rogers Silver Plate Co. and the suit grew out of a violation of contract. The referee allowed the company about \$4,500.

### A Receiver Petitioned for Smyth & Ashe.

ROCHESTER, N. Y., Jan. 9.—Yesterday morning Judge Werner granted an order to show cause why a receiver should not be appointed for the jewelry firm of Smyth & Ashe, doing business at the corner of Main and Front Sts. The order was made returnable this morning at the Special Term, but action has been postponed and a dissolution will be arranged.

It was generally supposed that the firm were doing a large business. Their stock of jewelry, while not very large, is one of the most select in the city. The firm opened the store at the corner of Main and Front Sts. about a year ago. A disagreement between the partners, it is said, is the cause of the present trouble, and, indeed, it is said the action taken by one of the members of the firm in applying for a receiver was a total surprise to his business partner.

The firm is composed of Frank A. Smyth and Thomas F. Ashe.

### A Case of Grand Larceny Against James S. Smyth.

ROCHESTER, N. Y., Jan. 13.—James S. Smyth, a brother of Thomas A. and Frank Smyth, jewelers of this city, is under arrest in Buffalo, charged with grand larceny. The prisoner formerly kept a jewelry store in Buffalo, but some time ago sold the stock to a Dr. McNames. The doctor says he bought the stock to aid Smyth, and intended to retain him as manager on a salary. He paid a part of the price in cash and gave a chattel mortgage for the remainder. On Thursday Smyth entered the store and told the clerk that he came for some jewelry which belonged to him. It is said that he took \$2,500 worth of diamonds and \$800 worth of watches. When Dr. McNames learned of this he caused the arrest of Smyth. He was arraigned in Police Court, Friday, and admitted to bail on the sum of \$1,000. His brothers in this city are the sureties.

Thomas A. Smith, of this city, gives the following version of the affair: "My brother was not successful in a financial way, in his business and he executed a bill of sale to Dr. McNames for \$3,700. With this he was to pay his minor debts and as much of the money as I had loaned him as he could. He was to work on salary for Dr. McNames. McNames paid him \$1,000 and refused to pay the rest. Acting on my advice and the advice of his attorney my brother then took as much of the stock as would cover the amount due him and executed a bill of sale of the same to me to cover the amount due me. The goods were his own and there was no theft. He has done nothing wrong and we stand ready to prove that there is \$2,700 coming to him from McNames which the latter refuses to pay."

A dispatch from Buffalo states that James S. Smyth has confessed that he gave the jewelry to his brother Thomas, of this city. Judgments in favor of Thomas S. Smyth for \$4,836.77, and John B. Humphrey for

\$341.89, have been filed against James S. Smyth in the County Clerk's office at Buffalo.

### The Mysterious Robbery of a Tray of Gems in E. Schall & Co.'s Store.

HARTFORD, Conn., Jan. 12.—A tray of valuable diamond rings was stolen from the jewelry store of the Ernst Schall Co. some time Thursday afternoon. A conservative estimate of the value of the jewels is \$5,000. That the robbery was accomplished in broad daylight and the thief escaped without leaving a trace of his work adds to the mystery and makes the detection of the criminal almost uncertain.

The force of the store was short handed. J. R. Stevens, who is ordinarily in charge of that part of the store fronting on Main St., went to New Haven early in the morning. One of the clerks was also away. This left the front store in charge of Mr. Schall himself. Some time between 12 and 1 o'clock a woman went into the store and approached Mr. Schall, who was behind the counter on the right. She was apparently about 40 years old, dressed in dark clothing, and was of dark complexion. This is about all Mr. Schall remembers of her appearance. She handed Mr. Schall an opal scarf pin, and asked him how much it would cost to have it set in a ring. Mr. Schall stepped to the show window where the tray of most valuable rings was kept and took an opal ring from the tray and showed it to the customer. She made no bargain, but left the store. Mr. Schall returned the ring to the tray in the window, and that, so far as can be learned, is the last anyone saw of the tray.

About 12.45 Mr. Schall went to dinner and returned about 2 o'clock. While he was away two clerks were supposed to be in the front of the store. Perhaps both may have been, for a few minutes, in the rear part. After Mr. Schall returned he was practically alone in the front store. This was undoubtedly the opportunity of the thief. The two clerks and the watchmaker were in the rear store. It was a stormy day and few customers were in. Mr. Schall cannot say but what he did step into the rear store during the afternoon. If he did, he left the whole length of the front store unprotected, and there was ample opportunity for an expert thief to sneak in and get the diamonds.

Thursday night Mr. Schall communicated with the police, and this morning he had a long talk with Chief Bill. The outgoing trains have been watched, but of course it is a case of locking the stable door after the horse is stolen. The tray contained 36 rings, the most valuable in the store, and two pairs of diamond earrings. The earrings were worth from \$250 to \$300 a pair, and some of the rings were worth \$600 each.

Mr. Schall has offered a reward of \$1,500 for the arrest and conviction of the thief or thieves and the return of the stolen articles.

**Boston.**

Mrs. N. H. Brown is in New York on a business trip.

Extensive alterations have been made since the holidays in the store of George H. Richards, Jr. & Co.

William S. Brown, of the E. Howard Watch & Clock Co.'s Boston office, is ill with typhoid fever.

George W. Wells, of the American Optical Co., was in the Hub during the past week, on a brief business trip.

Harry E. Howard, of the E. Howard Watch & Clock Co.'s Chicago office, has been in town during the past week.

Edson H. Burnham, optician, 572 Washington St., has assigned to A. G. Barber, of the Globe Optical Co. No statement of his liabilities and assets has been made public as yet.

Edwin P. Wells, of Southbridge, for seven years in charge of the gold department of the American Optical Co., will be connected with the Globe Optical Co., of this city, after Feb. 1.

W. R. Donovan, formerly with A. G. McKenzie, has taken quarters at 235 Washington St., and will carry a line of spectacles and eyeglasses, making a specialty also of prescription work.

The next meeting of the New England Association of Opticians will take place Jan. 21, at Young's Hotel. Dr. Homer A. Huntington will address the meeting and describe the workings of the phoro-optometer, his invention for correction of astigmatism.

In about another month the E. Howard Watch & Clock Co. will place on the market the most expensive American watch made at the present day. A model of the movement, which is a 17 jewel 18 size, is now exhibited at the Boston office of the company.

The annual meeting of the Boston Jewelers' Club will be held early in February. The election of officers is the most important business in prospect, and action will be taken in preparation for the annual ladies' night banquet, which is usually assigned to an evening in the latter part of March.

F. G. Butler, of F. G. Butler & Co., was complainant in the New York courts, Friday, against Henry Camp, of Boston, alias Babcock, alias Morris, who is wanted in this city on a number of charges. He did a loan business here, and is said to have pawned a diamond ring procured from Mr. Butler on memorandum.

Henry Guild, of Henry Guild & Son, last year completed a half century of business life, the firm being founded in 1844. Another house which dates back more than fifty years, having been founded in 1839, is the E. B. Horn Co., of which Edwin B. Horn is president. Mr. Horn succeeded his father on the death of the latter in 1872.

The Pratt clock establishment, heretofore located on Hawley St., has taken a hand-

some, well lighted store at 53 Franklin St., and is stocking up with some elegant lines of clocks. Daniel F. Pratt and Frank W. B. Pratt, the present proprietors, retain the old firm name, Daniel Pratt's Son. The house has taken the New England agency for the Waterbury Clock Co.

Albert N. Wood, who presided at the recent meeting of retailers and was authorized to appoint a committee on officers who should submit a list of nominees at the meeting to be held Jan. 17, has named the following gentlemen as members of the committee: Charles W. Morse, of Brookline; Luther Harrington and John Wilson, of Boston; John D. Grant, of Lowell; Harry Tisdale, of Taunton. The meeting was originally set for Jan. 15, but has been adjourned to the 17th, to suit the convenience of the Chamber of Commerce, in whose rooms the meeting will be held.

**Philadelphia.**

Hollingshed Bros. & Co. have made elaborate improvements at their establishment, 108 S. 5th St.

The sheriff's sale of the effects of the firm of C. R. Smith & Son took place last week. The general public attended the sale liberally, and it is expected that the amount realized will be quite handsome.

The traveling fraternity was represented in Philadelphia the past week by J. D. Pettingill, Derby Silver Co.; B. A. Noble, Payton & Kelley; Chas. Power, Ludeke & Power; Wm. Mount, Quayle & Co.

The difference between Frederick Betz and his son, Harry F. over the abstraction by the latter of the books of the embarrassed jewelry house, have been temporarily bridged by the presentation of an account by Harry F. to the assignee.

Jewelers here on purchasing business included: Joseph Ladomus, Chester, Pa.; A. Thoss, Royer's Ford, Pa.; A. Doran, Mt. Holly, N. J.; E. H. Williams, German town, Pa.; and Howard Fitzsimmons, West Chester, Pa.

Emma Becker, a middle aged woman was arrested on Saturday and committed for trial on the charge of shoplifting at

Mitchell's jewelry store, 58 N. 8th St. While making a purchase she is said to have picked up a \$25 watch and hid it in her sleeve.

Additional claims were filed last week with auditor S. M. Hyneman by creditors of the Philadelphia Optical & Watch Co. Mr. Hyneman will fix an early date which will be a limit of the time in which claims can be received, and the distribution of the fund will follow.

Judge Hamm, on Tuesday last, filed an adjudication in the Orphan's Court of the account of Simon and Jacob Muhr, executors of the estate of their father, Henry Muhr, who died in November, 1892. Under the will a house was left to the daughter, Sophia Stern. Bequests of \$500 each were made to the Jewish Foster Home Society and the Pennsylvania Society for Protecting Children from Cruelty. The residue was placed in trust for the benefit of the widow for life. The balance on hand was \$33,-245.81.

John Trainer, alias John Tobin and Charles Wilhere, alias Joseph Welsh, were committed for trial by Magistrate Pole on, Thursday, on the charge of robbing Milton Kirkenloger's jewelry store, 4377 Main St., Manayunk, on the previous Sunday. The place was entered by forcing open a cellar window, and thence through a trap door. One of the jewelry cases was broken open and \$200 worth of articles was carried away. The men were arrested on suspicion at Columbia, Pa., and were brought back here by Detective Tate and Mr. Kirkenloger, who identified them as residents of Manayunk. Some of the stolen property was found in their possession. The accused denied the robbery, and said they had found the plunder in a shed.

A young fellow who tried to do the stupid dodge, but whose black eyes were altogether too sharp to give credence to this idea, was arrested in the Arcade jewelry store, Fort Wayne, Ind., last week. He went into the place and looked at almost every article on exhibition, then took a seat in close proximity to the safe and went off into a pretended stupor. He was rudely awakened by an officer. He told three stories entirely different in detail.

365 DAYS AHEAD OF THEM ALL

Apply at Once for Catalogue and AGENCY FOR

**BEATING BICYCLES**

SEE THAT CURVE

FACTORY HOLYOKE MASS

Jewelers make good agents and get more profit on one bicycle than on six average watch sales.



Traveling representatives may consider these columns open for the publication of any news or items of interest regarding themselves or their confreres.

**R.** D. TUTWILER and E. B. Whitaker, travelers for R. Wallace & Sons Mfg. Co., are spending a few days at the factory preparatory to making their annual trips in the south and east.

W. A. Bigelow has been engaged to represent W. H. Bell & Co., Attleboro Falls, Mass., on the road.

Charles H. Clark, formerly with J. G. Cheever & Co., was in Chicago last week in the interest of J. F. Sturdy's Sons.

John J. Hawkes, who has been salesman for the Morrill Bros. Co., Boston, for ten years, will represent Hayden W. Wheeler & Co., New York, after Feb. 1.

Joseph Cowan, who has been on the road several years as the representative of the house of Henry Cowan, Boston, will start in the material business, Feb. 1, at 424 Washington St., Boston.

W. C. Sisco, a well known traveler from Chicago, will carry two lines the present year, L. Kaufman & Co.'s stone set rings and the Ansonia Clock Co.'s line. Mr. Sisco left for the east Saturday.

"Have taken more orders the present year than ever before, the Fall being an exceedingly good season. Business throughout my district is very encouraging and dealers are well pleased"—Mr. Tyler, traveler for Ansonia Clock Co.

Hammond Morton Tenney, for 12 years with Lapp & Flershem, and one of Chicago's most popular travelers, was wedded Jan. 8, at the First Baptist Church, Galesburg, Ill., to Miss Blondella Pollock, daughter of Dr. and Mrs. Pollock, of that city. Paul Shordiche and Morris E. Wolfe, of the traveling force of Lapp & Flershem, acted as groomsmen, and in speaking of the event, Morris said, "We simply owned the town." The irrepressible Paul went on softly humming, "There's only a few of us left." A large reception followed the wedding, Mr. and Mrs. Tenney leaving immediately after for a honeymoon in Cuba, via New Orleans.

Traveling men in Indianapolis, Ind., last week included: F. H. Gladding, Gladding & Coombs Bros.; J. F. Ridley, Watson, Newell & Co.; W. H. Lee, W. E. Webster & Co.; H. E. Cobb, Daggett & Clap; Mr. Fowler, Fowler Bros.; F. S. Gilbert; Mr. Mockridge; A. H. Oakley, Thornton Bros.; E. W. Fenger, The Natchaug Silk Co.; C. W. Battey, Waite, Mathewson & Co.; Geo. Paine, E. I. Franklin & Co.; Ernest Block, W. & S. Blackinton; N. F. Swift, E. D. Gilmore and G. K. Webster; Mr. Greene,

A. A. Greene & Co.; Mr. Cutler, F. H. Cutler & Co.; George Pearce, Short, Nerney & Co.; representatives of S. E. Fisher & Co., G. A. Dean & Co., Baldwin, Ford & Co.; E. L. Mumford, Waite, Thresher Co.; W. H. Tarlton, Wightman & Hough Co.; G. B. Angell, E. L. Logee & Co.; Robt. Moorhead, R. L. Moorhead & Co.; Jack Fuller, Fuller & Mayer; Mr. O'Donald, Courvoisier-Wilcox Mfg. Co.; G. B. Caldwell, Plainville Stock Co.

Traveling men in Boston, Mass., the past week included: Fred. H. Carpenter, R. F. Simmons & Co.; Harry Hildebrand, for R. C. Lindol; Louis Blackinton, W. & S. Blackinton; Henry G. Thresher, Waite, Thresher Co.; W. H. Tarlton, Wightman & Hough Co.; Mr. Kurtz, George W. Cheever & Co.; Ed. Gowan, Watson, Newell & Co.; Joseph Fowler, Fowler Bros.; D. F. Adams; R. E. Draper, Daggett & Clap; E. A. Potter; E. W. Martin, Martin, Copeland & Co.; Mr. Whitney, S. E. Fisher & Co.; J. M. Morrow, American Watch Case Co.; Charles T. Gallagher, Sinnock & Sherrill; W. S. Campbell, Day & Clark; Mr. Platt, Foster & Bailey; George H. Cahoon; Charles S. Isabel, L. Strasburger's Son & Co.; E. H. Cox, Sussfeld, Lorsch & Co.; E. B. Whittaker, R. Wallace & Sons Mfg. Co.; T. B. Wilcox, Jr., Pairpoint Mfg. Co.; Mr. Call, Simpson, Hall, Miller & Co.; H. B. Beach, Wilcox Silver Plate Co.; C. H. Barney, Middletown Plate Co.; Chris. Morgan, Rogers & Brother; Luther Townsend, E. Aug. Neresheimer & Co.; Charles L. Power, Ludeke & Power; J. D. Pettengill, Derby Silver Co.; Horace W. Dunham, Meriden Silver Plate Co.; Col. John L. Shepherd, Keystone Watch Case Co.; Mr. Breeden, W. S. Hedges & Co.

There was a "holocaust" of traveling men in Chicago the past week, and they did business, too. Good nature was mirrored in the faces of C. I. Brown, Geo. H. Cahoon & Co.; Fred Mockridge Mockridge & Buckenfield; Wm. P. Mockridge, W. P. Mockridge Mfg. Co.; Mr. Kent, Weaver & Co.; Chas. H. Clark, J. F. Sturdy's Sons; Mr. Melcher, Bennett, Melcher & Co.; G. C. Hudson, H. F. Barrows & Co.; Mr. Fitzgerald, M. Fitzgerald & Co.; J. W. Phillips, Hamilton & Hamilton, Jr.; Wm. Mount, T. Quayle & Co.; C. M. Vaslet, E. B. Thornton & Co.; W. H. Tarlton, Wightman & Hough Co.; E. L. Mumford, Waite, Thresher Co.; Mr. Whiting, S. E. Fisher & Co.; I. C. Nicholson, Flint, Blood & Co.; representative of Lothrop & Livsey; Wm. A. Wightman, R. F. Simmons & Co.; Ernest Block, W. & S. Blackinton, Everett I. Rogers, Parks Bros. & Rogers; E. M. Knapp, The Seymour, Knapp, Warren Co.; Mr. Ripley, Watson, Newell & Co.; Mr. Stern, Young & Stern, W. A. Griffith, R. L. Griffith & Son; M. L. Jacoby, Providence Stock Co.; Harry B. Kennion, H. D. Merritt & Co.; Mr. Oakley, Thornton Bros.; C. W. Battey, Waite, Mathewson & Co.; representative of J. M. Fisher & Co.; Everett B. Bliss, Bliss Bros.; John

Lamb, T. I. Smith & Co.; S. O. Bigney, S. O. Bigney & Co.; C. A. Marsh, C. A. Marsh & Co.; Mr. Tiffany, F. H. Sadler & Co.

#### MEETING OF THE BROTHERHOOD OF TRAVELING JEWELERS.

The Brotherhood of Traveling Jewelers, a benevolent organization composed of 100 travelers in the jewelry trade, held their annual meeting in Parlor B of the Astor House, New York, Wednesday afternoon. A large number of the members attended. President John W. Taylor made an address that was listened to with great interest. He was followed by E. V. Clergue, the chairman of the executive committee, who told of the good work done by the organization. C. A. Boynton, the secretary and treasurer, submitted his report showing the Brotherhood to be in an excellent financial condition.

The following officers were then unanimously elected: President, E. V. Clergue, of the E. Howard Watch & Clock Co., succeeding John W. Taylor; vice-president, C. C. Offerman, of Wm. Smith & Co., re-elected; secretary and treasurer, C. A. Boynton, of Wm. B. Kerr & Co., re-elected; chairman of the executive committee, D. V. P. Cadmus, of C. F. Wood & Co., succeeding E. V. Clergue. The other members elected to the executive committee are: H. A. Bliss, of Kremetz & Co.; E. H. Eckfeldt, of Eckfeldt, Ackley & Woodland; S. B. Kent, Wm. H. Ball & Co.; and E. L. Brown. J. F. Townley, F. H. Miller and Herbert Barker were admitted as members of the Brotherhood.

#### Canada and the Provinces.

W. Sloan, jeweler, of Milton, Ont., has assigned to W. B. Irving.

Cohen Bros., manufacturing jewelers, were burned out in the large fire which occurred in Toronto last Thursday.

An assignment has been made by Mason & Peterson, jewelers, Vancouver, B. C. They have been in business since August 1891, and did a fair trade; but, being anxious to do more than they were able, they find a heavy stock on hand, and their assets are mortgaged for \$765. Now they have liabilities of \$4,000 or \$5,000.

On Sunday morning, Jan. 6, the *Globe* building, with McKirnon's new block, Nicholas Rooney's silk warehouse and Webb's restaurant, Toronto were completely destroyed by fire. The jewelry establishment of H. Benham & Co., which is immediately opposite the *Globe* building, suffered, all their plate glass windows being broken by the intense heat. All their signs were burned and these will have to be replaced with new ones. The firm's loss was fully covered by insurance, which the Coy Commercial Union paid two days after the fire. Edmund Scheuer, jeweler, also suffered a slight loss through water. He was fully insured.



# The Jewelers' Circular

AND  
HOROLOGICAL REVIEW.

PUBLISHED EVERY WEDNESDAY BY

THE JEWELERS' CIRCULAR PUB'G CO.,

189 BROADWAY, NEW YORK CITY.

A JOURNAL DEVOTED TO THE INTERESTS OF JEWELERS, WATCHMAKERS, SILVERSMITHS, ELECTRO-PLATE MANUFACTURERS, AND ALL ENGAGED IN KINDRED BRANCHES OF INDUSTRY.

Our Editorial columns will contain our own opinions only, and we shall present in other columns only what we consider of interest or value to our readers. Advertising matter will not be printed as news.

Advertising rates in THE CIRCULAR are lower, considering the number of tradesmen reached by its large circulation, than in any other jewelry journal.

Notices of changes in standing advertisements must be received one week in advance; new matter can be received up to Monday.

## INFORMATION FOR SUBSCRIBERS.

### Terms of Subscription, Postage Prepaid.

	PER ANNUM.
United States and Canada, - - -	\$2.00
Foreign Countries in Postal Union, - - -	4 00
Single Copies, - - - - -	.10

New subscribers can commence at any time.

Payments for THE CIRCULAR when sent by mail, should be made in a Post-Office Money Order, Bank Check or Draft, or an EXPRESS Money Order or Registered Letter. All postmasters are required to register letters whenever requested to do so.

Pay money only to authorized collectors having proper credentials.

Returning your paper will not enable us to discontinue it, as we cannot find your name on our books unless your address is given.

In changing address always give the old as well as the new one. Your name cannot be found on our books unless this is done.

We will continue to send papers until there is a specific order to stop, in connection with which all arrears must be paid; but such an order can be given at any time, to take effect at the expiration of the subscription. All such orders will be promptly acknowledged by mail.

The Courts have decided that all subscribers to Journals are responsible until arrears are paid in full and an order to discontinue has been received by the publisher.

Member of the American Trade Press Association.

Vol. XXIX. Jan. 16, 1895. No. 25.

*Every line of reading matter in THE JEWELERS' CIRCULAR, with the exception of the few brief extracts from exchanges always properly credited, is written exclusively for this journal. Each issue of THE JEWELERS' CIRCULAR is copy-righted.*

**Marked Progress** MARKED progress was reported during the past week in the matter of obtaining legislation in the States of the Union regulating the stamping of silver wares. From South Carolina the following communication was received by THE CIRCULAR:

CHARLESTON, Jan. 9, 1895.

DEAR CIRCULAR:—I mailed you newspaper by this mail to let you see that the bill passed in our Legislature and has now become a law of the land requiring silver to be up to the standard as stamped.

Yours truly,

JAMES ALLAN.

The measure, which was passed Jan. 6, is that drafted by THE CIRCULAR, with section 3, referring to penalty, revised; it is as follows:

SECTION 1. A person who makes or sells or offers to sell or dispose of, or has in his possession with intent to dispose of, any article of merchandise marked, stamped or branded with the words "sterling" or "sterling silver," or encased or enclosed in any box, package, cover or wrapper, or other thing in or by which the said article is packed, enclosed or otherwise prepared for sale or disposition, having thereon any engraving or printed label, stamp, imprint, mark or trade-mark, indicating or denoting by such marking, stamping, branding, engraving or printing that such article is silver, sterling silver or solid silver, unless nine hundred and twenty-five one thousandths of the component parts of the metal of which the said article is manufactured are pure silver, shall be deemed guilty of a misdemeanor.

SECTION 2. A person who makes or sells, or offers to sell or dispose of any article of merchandise marked, stamped or branded with the words "coin" or "coin silver," or enclosed in any box, package, cover or wrapper, or other thing in or by which the said article is packed, enclosed or otherwise prepared for sale or disposition, having thereon any engraving or printed label, stamp, imprint, "mark" or "trademark" indicating or denoting by such marking, stamping, branding, engraving or printing that such article is "coin" or "coin silver," unless nine hundred and twenty-five one-thousandths of the component parts of the metal of which the said article is manufactured are pure silver, shall be deemed guilty of a misdemeanor.

SECTION 3. Whoever violates the provisions of either of the preceding sections shall, upon conviction, be subject to a fine not exceeding one hundred dollars for each offense or be imprisoned in the county jail not more than thirty days.

SECTION 4. This act shall take effect upon its passage.

Approved December 21, 1894.

From New Hampshire, the following communication from the prominent silversmithing firm of Wm. B. Durgin, gives almost positive assurance that legislation will govern the stamping of silver wares in that State.

CONCORD, N. H., Jan. 10, 1895.

JEWELERS' CIRCULAR PUBLISHING CO.,  
189 Broadway, New York, N. Y.:

GENTLEMEN:—In reply to your favor of Aug. 30, 1894, which accompanies the draft of a bill to be placed before the legislature of the various States, we desire to say that this bill has been presented to the New Hampshire Legislature by Mr. W. B. Durgin, a member of the House, from Ward 5, Concord.

Mr. Durgin will make an effort to secure the passage of the bill.

Very truly yours,

W. B. DURGIN,  
per Geo. F. D.

Thus gradually and surely will we obtain universal legislation to regulate the important matter of stamping of silver manufactures throughout the Union, and the trade in general will applaud those jewelers who have exercised their endeavors in this good cause.

### Woman Labor in Illinois.

A CASE which recently aroused much interest in Illinois was the arrest of Superintendent Hunter, of the Elgin National Watch Co., charged with violating the State factory law in relation to the employment of women. The defendant having been discharged by the court the State factory inspector requested presiding Justice Becker to give his reasons for his action, which he willingly did. It was shown that women have been employed in the Elgin watch factory more than eight hours in one day. It was admitted that Mr. Hunter had authority to

hire and dismiss employes, that he was an employe of the company, that all wages, etc., were paid from the company. It was proven that the defendant did not directly employ the women, but that other servants of the company did; that his department had no personal knowledge that these particular women were at work for the company. The prosecution arrested an individual, Mr. Hunter, conceded to be the executive officer of the company, though the law has no provision for the manner of punishing corporations for the violation of its enactments—certainly none for the arrest of an officer of a corporation for such violation. If Mr. Hunter was fined, the fine would have been against him as an individual. The Justice puts the question: Can an individual be made to suffer for the offenses of a corporation? He thought not, as such a proceeding would neither be good law nor good morals. As most factories are conducted by corporations, if this decision is allowed to stand, it will be practically impossible to enforce the eight-hour law as relating to women, at least in Illinois; and as the women themselves are thoroughly willing to work overtime, the non-enforcement of the law may produce, after all, little harm.

### The Goldsmith's and Silversmith's Arts.

LET every retail jeweler commit to mind the following extract bearing on stamping legislation from the address of Hon. C. Sidney Smith to the members of the Manufacturing Jewelers' Board of Trade, on the occasion of their 10th annual meeting and banquet, exclusively reported at great length in THE CIRCULAR of January 2. "The whole trouble lies with the consumer who is looking to obtain \$1.00 in value for 75 cents. Educate the consumer that an article of jewelry has an artistic value as well as a metal value and much of this trouble will be obviated." This journal has ever considered goldsmithing and silversmithing manifestations of the art instinct in man, and has taken all possible occasion to present noted works expressing the conceptions of artist minds. In deeming these crafts branches of art, the Europeans are ahead of the Americans who are inclined to look upon jewelry, silverware and kindred productions as prosaic merchandise. London manufacturers, as Streeter, advertise themselves far and wide as *art* goldsmiths and silversmiths, and it is such terms as this often reiterated, that cause the public to appreciate the æsthetic features of jewelry and silverware. Quantity does not govern the use of the word art, for the galleries and museums of the world contain hundreds of thousands of paintings and sculptures, the productions of individuals as Michaelangelo and Rubens numbering well into the hundreds, yes thousands. Goldsmithing and silversmithing are arts; let all jewelers always remember this fact and let them constantly repeat it.

### New York Notes.

C. Cottier & Son have entered judgment for \$3,410.67 against Chas. Seale.

N. W. Reane has entered a judgment for \$284.82 against Nathan Rogers.

The Gorham Mfg. Co. have filed a judgment for \$228.38 against Wm. S. Allen.

N. W. Holmes has entered a judgment for \$134.53 against Gerson Gootenberg.

A judgment for \$768.50 has been entered by R. A. Breidenbach against Isaac Rasowsky.

A judgment for \$650.56 has been entered against Wm. Llemand and Percival Leroy by John Eyre.

A. M. Bachrach has entered a judgment for costs amounting to \$12.15 against Joseph Robinson.

A judgment against the East Side Jewelry Exchange for \$245.48 has been filed by A. Reitman.

An electric light wire is said to have been the cause of a slight fire which broke out, Friday, in the jewelry store of Marks Myzel, 441 Eighth Ave.

Dr. R. H. Knowles, formerly instructor in the Spencer Optical Institute and recently with the Julius King Optical Co., is now giving instructions in refraction at his home, 110 W. 129th St.

B. C. & G. H. Tietze, manufacturers of cane and umbrella mountings, 191 Worth St., recently dissolved, and have been succeeded by Tietze & Weber, composed of B. C. Tietze and K. R. Weber.

The assignee's sale of the remaining effects of John B. Yates, formerly of 21 Maiden Lane, took place yesterday at the office of the Montgomery Auction & Commission Co., 132 Front St.

Deputy Sheriff Mulvaney, Wednesday, sold out the effects of John Klipper, wholesale dealer in jewelry and optical goods, 41 Maiden Lane. Klipper was closed out Dec. 26, on executions aggregating \$6,288.

The firm of I. Michelson & Co., composed of I. Michelson and M. D. Cohn, ring manufacturers, 41 John St., dissolved partnership Monday. Mr. Cohn retires and Mr. Michelson continues the business as before at the old address.

E. Kirstein's Sons Co., Rochester, N. Y., opened their New York office at 4 Maiden Lane, Monday. Geo. H. Griffin, formerly with the Julius King Optical Co., manages the New York branch, while Edm. Heurung looks after the city trade.

Louis M. Van Moppes, formerly a diamond cutter for the trade at 51 John St., is now associated with his father, M. L. Van Moppes, under the firm name of M. L. Van Moppes & Son. The diamond cutting factory which they opened last week at 81 John St., will run three mills.

Word was received in this city last week that Siegmund Davidson, formerly a diamond broker of 36 Maiden Lane, had died in St. Augustine, Fla. He was about 36

years old, unmarried, and had been in bad health for some time. Mr. Davidson was the brother of Salomon Davidson, 44 Maiden Lane.

Chas. L. Camerik, a clerk in the employ of the Spencer Optical Mfg. Co., who was arrested Jan. 3d on the charge of stealing opera glasses from his employers, was tried in Special Sessions Tuesday, Jan. 8th, and was sentenced to 30 days in the city prison. His companion, Henry Mayer, who was arrested as an accomplice, was discharged.

A sale by the sheriff, Friday, of the stock and fixtures of the East Side Jewelry Exchange, 332 Grand St., realized about \$1,800. The company, of which Adolph Raduziner was manager, was closed out Dec. 26 on two attachments—one for \$1,025, in favor of Max Speizer, and the other for \$225, in favor of Albert Reitman.

The firm of Bernheim, Cohen & Beer manufacturers of jewelry novelties, formed Jan. 1st, are now established in their quarters at 45 Maiden Lane. The members are Louis Bernheim, formerly with Leopold Weil & Co., Jno. M. Cohen formerly with Levy, Dreyfus & Co., and David Beer formerly with Leopold Weil & Co.

Frank L. Palmer, a clerk in Post Office Station A, who, as told in THE CIRCULAR last week, was arrested on the charge of embezzling letters addressed to Lynn & Co., jewelers, at 48 Bond St., was sentenced to two years' imprisonment in the Erie County penitentiary by Judge Benedict in the United States Circuit Court Friday.

Some of the creditors of Joseph Rundbach, 2168 Third Ave., who failed recently and is under indictment for attempting to conceal property in order to defraud his creditors, have obtained a settlement on their claims. Creditors seen by a CIRCULAR reporter, Monday, stated that their claims had been purchased by Mrs. Rundbach at 50 cents on the dollar. She gave five notes, endorsed by Dattelbaum & Friedman, due in three, six, nine, twelve and fifteen months.

Two attachments have been received by the sheriff against Benton C. Melton, retail jeweler, 417 Sixth Ave. One for \$459, in favor of Maurice Weil, and the other for \$439, in favor of Henry Froehlich. They were granted on the ground that he had departed from the State and disposed of his property. Melton disappeared Jan. 1st, and his store was closed out by the sheriff three days later. A sale of his effects, Friday, realized about \$400.

The handsome watch presented, Friday, by the board of officers of the 22d Regiment to Capt. E. E. Hardin, as an expression of their appreciation of his services as drill instructor to the National Guard of this State, was made by Tiffany & Co. The watch is an open-faced, 18 karat gold chronometer. On the back of the case are the Captain's initials, E. E. H., in the form of an intertwined cipher; on the inside is the inscription: Presented to Capt. E. E.

Hardin, 7th Inf., U. S. A., by the Officers of the 22d Regt., N. G. N. Y., January 11th, 1895.

In conformity with an order signed by Judge Patterson, of the Supreme Court, Dec. 3d, in the matter of the voluntary dissolution of the Kimberley Diamond Co., formerly of 861 Broadway, David J. Lees, the receiver, advertises a notice to all persons interested in the Kimberley Diamond Co., to appear before Wm. H. Ricketts, as referee, 36 Chambers St., on Jan. 23d, and show cause why the corporation should not be judicially dissolved.

On the application of Franklin Bien, as attorney for Henry Dreyfus & Co. and Justin Wertheimer, William H. Ricketts were last week appointed temporary receiver for Charles Seale & Co., a corporation formerly dealing in diamonds at 907 Broadway. Henry Dreyfus & Co. are creditors for \$3,539.50, and Justin Wertheimer for \$3,194. They obtained judgments on Oct. 4, 1893, but could never collect them. The creditors alleged that the company had large assets, consisting of diamonds, which passed into the control of Charles Seale, the president, and that the appointment of the receiver is necessary in order to institute proceedings to recover the property appropriated by the president. Mr. Seale made an assignment individually on May 31, 1893, to Edward B. LaFetra, with liabilities of \$96,000 and actual assets of \$28,000, and has not been able to effect a settlement with the creditors. A suit by the Gorham Mfg. Co. and other creditors, to set aside this assignment was tried before Judge Beach, of the Supreme Court, Nov. 21st and a decision is now pending.

The place of business of Abraham Schieber, an auctioneer, at 20 W. 14th St., was closed by deputy sheriff Heimberger Monday, on executions aggregating \$3,307, obtained by Erdman, Levy & Mayer, attorneys for twelve creditors. Schieber confessed judgments to the following creditors for a portion of their claims only: Max J. Cohn, \$509; Illinois Watch Co., \$468; Leon M. Hirsch, \$368; Niagara Silver Co., \$329; Nobis & Molle, \$268; John W. Johnson, \$218; Herman J. Muller, \$207.20; Leo Hammel, \$218; Leopold Lehman, \$193; William Wetstein, \$193; Bernard Gutter, \$168; M. E. Moore Bronze & Plate Co., \$168. Two more judgments were entered yesterday, one by Ferd. Bing & Co. for \$168, and one by the National Brass & Iron Co. for \$368. The business has been conducted under the name of Abraham Schieber, by Leopold Schieber, formerly of Frey & Schieber, wholesale jewelers, who failed about six years ago. At the office of Erdman, Levy & Mayer, a CIRCULAR reporter was told that the creditors to whom judgments were confessed, would probably realize the amount of the judgments, which averaged about 50 per cent. on the claims. The liabilities are estimated at between \$16,000 and \$18,000, and assets actually worth about \$5,000.

**L. TANNENBAUM & Co.,**  
IMPORTERS AND CUTTERS OF

**Diamonds and Precious Stones,**

Cor. Maiden Lane & Nassau St.

**NEW YORK.**

25 Hatton Garden, London.

TELEPHONE, LONG DISTANCE 1959 CORTLANDT.

## Special Announcement.

Mr. L. Tannenbaum begs to notify his customers and the trade in general, that he has largely extended his facilities for cutting and polishing. Hereafter he will cut and polish not only RUBIES and SAPPHIRES, which has been done for the past 15 years with increasing and gratifying success, but

## DIAMONDS

and all other stones which undergo this process.

Modern machinery of the best and most approved pattern, and workmen of the highest class will enable Mr. Tannenbaum to offer, direct from the cutter's hands, that excellent workmanship demanded by American buyers, at

## PRICES THAT DEFY COMPETITION.

Nor will buyers of Diamonds be the only people benefited. Mr. Tannenbaum imported a five years' supply of rough Rubies and Sapphires DUTY FREE under the old tariff. These goods are now being cut and polished and it is very evident that in these particular stones he can make UNAPPROACHABLE PRICES.

New York as the future Diamond Market is not a phantasy. American cutters will be shown an assortment of rough, at prices which will perhaps cause them to believe that this has already been brought about. All arrangements have been made by the firm for enormous shipments of DIAMONDS, EMERALDS, PEARLS, SPINELS, CATSEYES, MELLEES and all kinds of Precious Stones, although to-day the assortment offered by L. Tannenbaum & Co. ranks second to none in this country.

 HIGHEST PRICE PAID for all AMERICAN PEARLS and OTHER PRECIOUS STONES.

# THREE POPULAR \* FAVORITES

## TRILBY,

as a dainty blanchisseuse de fin, won all our hearts. Our new TRILBY Ladies' Chain, wins the heart and admiration, and the cash of every buyer. This is a fact.



## THE GAIETY GIRL

kicked her way into popular favor at once, but is even to-day nowhere near as strong a favorite as our new GAIETY GIRL Ladies' Chain. Have you seen it?



## THE DUCHESS,

with her aristocratic face and bearing, typifies the qualities of our new DUCHESS Chains. They sell at sight.



These are a few of our

many new **GOOD THINGS.**

Among others is a beautiful line of **GUARDS**, plain or with Beads, Pearls or Turquoise; some of the handsomest.....

**RIBBON SEAL FOBS** ever offered, and a line of **SEAL PONY CHAINS** that are **SELLERS**, every one.

We nearly forgot to mention our new **TASSEL GUARDS**. But you won't forget them once you see the goods.

EVERY FIRST-CLASS JOBBER CARRIES OUR LINES.

# W. & S. BLACKINTON,

**ATTLEBORO, MASS.**

## THE JEWELERS' CIRCULAR.

VOL. XXIX.

WEDNESDAY, JAN. 16, 1895.

NO. 25.

## 18TH ANNUAL MEETING OF THE JEWELERS' LEAGUE.

MASONIC TEMPLE, NEW YORK.

10 o'clock P. M., Jan. 15.

Though a few familiar faces were absent, through business and family exigencies, the meeting of the Jewelers' League of New York, to-night possessed the same air of fraternity and good-will which has marked the many previous assemblages of this benevolent organization. When the president called the meeting to order at 8 o'clock the assembled gentlemen represented a dispensed with. Mr. Hayes then made his proceedings of the occasion.

The reading of the secretary's report was goodly body who were interested in the pro-address as follows:

ADDRESS OF PRESIDENT HENRY HAYES.

*Fellow Members of the Jewelers' League:* One more revolution of the cycle of time has brought us to the threshold of our nineteenth year. We look over the past with its roll of death losses, with the depression of financial stress and with its ever changing scenes and conditions of life. Our own condition has in only a slight degree been consonant with the adverse experiences of so many of our neighbors. We can heartily congratulate ourselves upon the proud record maintained by the League amidst the discouragements or wrecks of nearly every enterprise. I feel safe in saying that the very small diminution of our membership is unequalled in the experience of any institution or association for life assurance. More than one of the many prosperous and well managed companies about us have been compelled during the past year to count their lapses by thousands, to their great discouragement, yet a fact asserted in accord with the personal declarations of their officers. Our members have been exceptionally loyal to their obligations while the sympathy of trade fellowship has stimulated them to respond generously to the calls for relief of the needy heirs of deceased associates. If we fully knew and appreciated the cheer and comfort conveyed to these worthy recipients, by our trifling contributions, we would forego the expected aid to our beneficiaries were the call made upon us in such manner. And here I take the liberty of quoting the words of another, which are exceedingly applicable to our own situation:

"Life insurance and hard times."

We have been living for many months in hard times, harder than most of us ever saw before, and harder, we trust, than any of us will ever see again. What effect has this prolonged period of idleness of scant earnings, of financial depression, had upon the great institution of life insurance? Have men, under the stress of lessened incomes, of positive and continual loss and shrinkage of values, given up their life insurance as a burden too heavy to carry, viewing it as a luxury well enough in good times but not a necessity to be maintained at any cost? Yes, now and then a man has felt thus, no doubt. But as far as the members of this association are concerned the great mass of them have steadily, persistently, yes, heroically, clung to their insurance, denying themselves for others and paying their premiums promptly.

Their action is not only a magnificent indorsement of the association, but reflects the greatest credit upon our members themselves.

We are strong in numbers, we are strong in finances. Never were the financial affairs of the League in sounder or more satisfactory condition. Every investment, and every dollar of money as reported by our treasurer, are intact, and if assurances were needed in these days of doubt and distrust on every side, your officers and Executive Committee would insure the accuracy of the report of your able and exacting Auditing Committee. Neither has an Executive Committee given more painstaking care of our entire interests, than the gentlemen who have served us for the past year. It may seem fulsome to annually sing the praises of the men who have always done their work in committee, but if you knew the thought, the time, and the labor so unselfishly given, you would admit that not half justice is done them by these words of commendation. The careful discrimination exercised in admission of new members, the assistance and advice bestowed on the details of our affairs and the devotion to our every interest, is not excelled in the administration of their private business.

Permit me to call attention to the wonderful and significant results of assessed life insurance companies. The figures are given by one of the ablest statisticians. For the past year there have been admitted 730,866 members. Total number of members at the close of the year, 3,478,100. Amount paid in by members for the year, \$85,198,200. Total payments to heirs of deceased members, \$59,708,000. Total expenses of conducting business, \$20,719,800. These stupendous and almost incredible figures show that the assessment system of insurance is not to be despised or ridiculed, and it is superior to the slanderous attacks so often made upon it. And here I desire to call to the minds of too many of our members the unfairness and carelessness with which they refer to the League. Ofttimes a member declares he has been compelled for several years to pay \$10 per month for assessments. A moment's thought should show him the fallacy and injustice of such an assertion. As a matter of fact there has never in any one year been assessed upon a member subject to a \$2 rate, over \$52 per annum or about \$5 a month, being just one-half the amount so flippantly stated. It is also a matter of record that during our entire existence the average cost to our members, per year, has been but \$33, or about \$2.75 per month, yet at this excessively low rate we have paid to beneficiaries a total sum of \$1,477,358.10. Would that such members might bear these facts in mind and present them to neighbors and friends, for thus would our membership be doubled within a year, and the old-time enthusiasm be revived for the League, by the members of the League, to the onward march of the League. In this connection I desire to commend to your confidence and consideration the general agent of the League, Mr. C. H. Higbee. His task is arduous and not fraught with unalloyed pleasure. You can often assist him in his efforts to present our cause to men whom we would be pleased to have with us, and can aid him by your favorable introduction of such persons.

The membership in Class B has not increased as rapidly as hoped for, but there is many a man anxious to join, only waiting for the bright clouds of prosperity to shine upon us, when he and hosts of others will swell our ranks and avail themselves of the advantages so strongly and justly urged by the worthy advocates of half-rate membership. Gentlemen, our association is sound and flourishing. You can double its advantages and beneficent influence by the smallest effort. Will you not make this effort?

The address was received with applause. The reading of the treasurer's report was dispensed with.

The chairman of the executive committee, Wm. Bardel, through business reasons, was absent, and the report of the executive committee was read forcibly by Mr. Van Deventer, as follows:

EXECUTIVE COMMITTEE'S REPORT.

*Mr. President and Fellow Members:*

The executive committee take pleasure in presenting the eighteenth annual report of the operations of the Jewelers' League.

It is made at the close of two years of depressed business, and yet we are glad to say that the organization is in first class condition and never was better equipped for the work it has to do, than it is at the present time.

Every member of this League should be proud of it as an organization, proud of the work that it has done in the year 1894 as well as in former years, rejoicing in the bright future that awaits us, providing that every member will do his utmost in speeches and by effort to uphold and push forward our work.

We have by no means reached the limit of our field or our ability for good in this work and need the efforts of all our membership in advertising our work and in the procuring of new members.

During the past year a new class of members has been opened known as Section B. Applications have commenced to come in for admission to it. The opening of this section has taken away about the only objection that has been brought against it in the past.

The passing to-night of the proposed amendment to our constitution Article III, Section 1, permitting officers to be elected from either section will remove the idea of any favoritism toward Section A.

Now that Section B has been started it becomes us as members of the League to boom both of these sections to the best of our ability; let no man say now he does not believe in Section B. It is here and is here to stay.

For years past we have been accumulating a reserve fund. This year of 1894 has been the first one in which the fund has been drawn upon. It comes in connection with a year of hard times, and hence has proved a double blessing, in that we have paid the death losses for our members (thirty thousand dollars) from this fund, and at the same time made it necessary to assess the membership for this amount.

The wisdom of providing such a fund has been thus demonstrated, so that there is no room in our counsels for any remarks regarding it, other than those of hearty approval.

With January 1, 1895 we commence making assessments monthly for as many deaths as we have been advised of, for the purpose of making assessments more frequent and for smaller amounts. The doing of this makes prompt response necessary, as extensions of time for payment will be impossible.

For details of the work we would respectfully refer you to the printed report of our secretary and treasurer.

We enter the new year full of hope and expectations for the prosperity of our League, and the business in

which we are engaged, and have only need to stand shoulder to shoulder in order that these hopes and expectations may be realized.

Respectfully submitted,

GEO. M. VAN DEVENTER.

The report was enthusiastically received. The report of the examining finance committee was the next proceeding, the reading of which was dispensed with. The report of the nominating committee was read by Mr. Jenks.

The election of officers was next in order. James P. Snow, first vice-president, was called to the chair. J. W. Beacham moved that the secretary cast one vote for Henry Hayes for president. Mr. Hayes accepted the responsibility in a graceful speech. He referred to the books and accounts of the League, being examined by an expert every two months, a detail omitted from the executive committee's report. He also referred to the remarkable lessening of the membership of the League, considering the conditions of the times during the past year.

J. B. Bowden was unanimously elected 3d vice-president without any opposition. Applause greeted his election. Geo. R. Howe declined re-election to the 4th vice-presidency, owing to the condition of his health, and Wm. Bardel was unanimously elected to that official position. The next business was the election of members of executive committee for years. David Untermeyer was elected, as were Mr. Van DeVenter and Mr. Beacham, who has been an earnest worker in the interests of the League. O. G. Fessenden, George W. Parks, Charles L. White, and John W. Steele were elected unanimously.

There was no unfinished business, and Secretary Stevens proceeded to read the following proposed amendment as miscellaneous business:

#### ARTICLE III., SECTION I.

##### OFFICERS AND ELECTIONS.

Its officers shall consist of a president, four vice-presidents, respectively designated as first, second, third and fourth, and an executive committee consisting of the officers ex-officio and six other members, all of whom shall be elected by ballot, as hereinafter provided, from members engaged in the jewelry or kindred trades, and shall continue in office during their respective terms and until their successors shall be elected and qualify, except such as shall be removed, as hereinafter provided.

Mr. Frank proposed an amendment to this as follows:

*Add to ARTICLE III., Section 1.*

There shall also be an Advisory Board, consisting of twelve members who shall be elected by ballot as hereinafter provided for from members of Sections A and B.

Such Advisory Board shall hold office for one (1) year and until their successors shall be elected.

Mr. Hayes interpreted the constitution to exclude the proposed amendment of Mr. Frank. This gentleman argued the legality of the decision of the President.

President Hayes responded that it would be unfair not to consider the amendments in order, aside from the question of parliamentary law governing such action. He

argued his position in the matter subject to appeal. Mr. Frank retaliated that both amendments were a part of each other, and that they should be so considered, his argument being that it would be too late to consider the second part after the first article had been adopted. Mr. Hayes was afraid such a treatment might be an injudicious precedent, and did not see his way clear to consider them together. To his mind it seemed equitable and fair to have a separate vote on the amendments. Sec. 1, art. 3, he desired placed for voting. Mr. Frank expressed himself as being too respectful of the chair to continue "fractious." Mr. Brown was requested to explain his reason for proposing the amendment, and did so to the effect that members of class B were as much entitled to officership as members of class A.

Mr. Frank then desired to know the status of the advisory board, upon which Mr. Bowden called for a point of order. Mr. Beacham argued that any member of the League should be eligible to officership and objection being made to this broad idea, Mr. Hayes put the question and the amendment was accepted. Secretary Stevens read the next proposed amendment as follows:

*Add to Amendment on Nominating Committee.*

The Nominating Committee shall make nominations for but six (6) members of the Advisory Board. The other six and all additional nominations for the Advisory Board shall be made at the Annual Meeting. *Strike out Section 4, ARTICLE III., and insert:*

The First Advisory Board of the twelve members shall be elected at the 1895 Annual Meeting.

*Strike out Section 2, ARTICLE IV.*

*Make Section 3 Section 2.*

*Make Section 4 Section 3.*

*Make Section 5 Section 4.*

*Insert Section 5, Article IV.*

It shall be the duty of the Advisory Board to cooperate with the Executive Committee in all matters concerning the good and welfare of the League. The Advisory Board shall, from time to time, examine the books, accounts, moneys and property of the League, and at least once a year shall cause a thorough examination to be made of the affairs of the League. This examination shall be made by an expert accountant under the direction of the Advisory Board. The Executive Committee shall make suitable provision for the payment of such accountant's services. It shall be the duty of the Advisory Board to report upon the books, accounts, vouchers of the treasurer, and on all securities, investments and property of the League in the keeping of the Executive Committee.

These reports shall be made at the First Annual Meeting succeeding the election of each Board or at any special meeting called for the purpose.

*ARTICLE IX., insert:*

SEC. 2.—The Executive Committee shall call a special meeting of the League at any time upon the application, in writing, of seven members of the Advisory Board for the purpose of receiving and acting upon any report and recommendations of the Advisory Board.

*Make Section 2 Section 3.*

Mr. Frank proposed that the amendments be adopted *seriatim*. The motion was lost. M. D. Rothschild then rose and made a long and eloquent speech. He said that the past two years had seen marked trouble in financial institutions. He read from an able article in the *Sun*, advocating stringent

safeguards in financial institutions, the gist of which was as follows:

No man, no matter how good his character is, or how long his services may be known, should be trusted singly with another man's money. Whether a man is president of a bank or the youngest clerk in it, it should be the duty of some other man to watch him and the duty of a third man to see the second man watches the first one \* \* \* \* \* \* \* Where every man is honest none need be afraid of inspection. Where inspection is regularly and carefully performed as a matter of strict duty it soon ceases to carry with it any imputation of dishonesty. Only by frequent, thorough and impartial inspections can the weak members of a bank's staff be kept beyond the reach of temptation. And it is always impossible to say whether the weakest member is the president or the youngest clerk.

This extract was made the *motif* of a long and able address, advocating the instituting of more thorough safeguards around the financial circumstances of the League. He compared the selection of the secretary and treasurer at the present day, with that at the time when the executive committee did not have the matter in their jurisdiction. He designated the examining finance committee as a farce, arguing that they cannot examine the finances in the short time usually devoted to it. "It is a physical impossibility that they should know anything about the books," he said. He cited the fact that the examiners of the banking institutions were an able and unprejudiced set of men. He read the following letter bearing on the subject:

STATE OF NEW YORK,  
INSURANCE DEPARTMENT,  
ALBANY, Jan. 4th, 1895.

M. D. Rothschild, 41-43 Maiden Lane, New York City.

DEAR SIR:—In reply to yours of the 21st ult., I would inform you that the last examination made by this department of the Jewelers' League, of New York City, bears the date of Jan. 21, 1886. I enclose for your information a printed abstract of the annual statement of said association, made to me for the year ending Dec. 31, 1893, which is my latest information regarding it.

The insurance law does not require such association to be examined every year, and I am unable just at this time to inform you when an examination of said association will be made.

Yours respectfully,

JAMES F. PIERCE,  
Superintendent.

NEW YORK, Jan. 15, 1895.

Mr. Rothschild further believed that it was high time that the executive committee should make laws and see they were carried out. He thought that 12 heads would be better than six, as they would constitute an examining finance committee. He differentiated the executive committee from the advisory board, reading extracts from the constitution relating to the duties of both bodies. Both bodies, he claimed, are to cooperate, and the advisory board will be a standing examining finance committee. The nut is, he said, that the advisory board shall have something to do.

# Why Experiment WITH AN Untried Scheme?

When  
You  
Want  
Life  
Insurance

YOU want it in a company whose plan is based on **STERLING BUSINESS PRINCIPLES** and WHICH WILL BE IN EXISTENCE AT THE TIME OF YOUR DEATH.

◀ This Result

CAN only be accomplished by the **GRADUATED PREMIUM PLAN**, where each assured person pays a sum based upon an equitable calculation, according to his age. Is it not manifestly **UNFAIR** that **OLD** and **YOUNG** alike should pay the **SAME** rate? Which of the two will benefit sooner?

////// THE ////

## Jewelers' & Tradesmen's Company.

OFFICERED BY CAPABLE AND EXPERIENCED MEN.  
HAS AN EQUITABLE GRADED PREMIUM PLAN.  
HAS NOT ONE SINGLE LEGITIMATE UNPAID CLAIM.  
GROWS STEADILY AND SOLIDLY.  
INCREASES ITS RESERVE FUND WITH EACH PREMIUM PAID.  
THE YOUNG MAN PAYS LESS THAN THE OLD.  
A PAID UP POLICY IS GUARANTEED AT THE END OF 15 YEARS.  
MEMBERSHIPS FOR ANY AMOUNT, FROM \$1,000 TO \$5,000.  
POLICIES IN FORCE, OVER FOUR MILLIONS.

## The Jewelers' & Tradesmen's Company.

SHUBAEL COTTLE, President.

E. S. JOHNSON, Jr., Secretary.

HOME OFFICE:

**POSTAL BUILDING,**

253 BROADWAY,  
Cor. Murray Street,

NEW YORK.

A Postal Card will insure a visit from our Representative.

Circulars and Rate Prospectus on Application.

An Insurance man of experience says: "In my opinion, no company, having a cast iron assessment, alike for both young and old, can have any permanent existence."





### An English Syndicate Corners the Diamond Product.

A dispatch received in New York last week stated that an English syndicate had completed a deal by which they were to obtain the entire output of the De Beers Consolidated Mines for 1895. The dispatch stated that the diamond output for this year was estimated at about £3,250,000 or \$16,250,000.

Communications received by L. & M. Kahn & Co., Jos. Frankel's Sons, Stern Bros. & Co., and other large diamond houses of New York showed the dispatch to be practically correct. Diamond dealers whom a reporter of THE CIRCULAR saw Monday were unanimously of the opinion that the result of this deal would be to strengthen the market here, and many were of the opinion that a rise in prices would necessarily ensue.

It is stated that an Amsterdam and an Antwerp syndicate were competitors of their English rival in the attempt to corner the diamond product.

### Wm. H. Atwater Completely Exonerated From a Baseless Charge.

The examination of Wm. H. Atwater on a charge of larceny preferred by James McKeon, took place in the Tombs Police Court, New York, Tuesday afternoon last before Police Justice Grady, with the result that Mr. Atwater was completely exonerated. Mr. Atwater was arrested Dec. 14, as told in THE CIRCULAR at that time, at the instigation of McKeon, who claimed to be representing Fd. & Ch. Pierre, clock dealers of Paris, for whom Mr. Atwater had been acting as the New York agent.

McKeon alleged that Atwater wrongfully withheld \$283.50 being the amount of two bills of clocks sold to Hilton, Hughes & Co. Upon seeing the contract submitted by Mr. Atwater, Justice Grady appeared satisfied that Mr. Atwater was justified in his course, but adjourned the case until last week. When the examination came up Tuesday, after hearing the complainant, the justice immediately dismissed the complaint without even hearing Mr. Atwater, and stated that the warrant had been issued under a misapprehension.

### Frank Bayerdoerfer Makes an Assignment.

Frank Bayerdoerfer, an importer of watches and diamonds, at 41 Maiden Lane, New York, made an assignment Jan. 7, to John J. Connelly, giving preferences to Mary Ubele, \$800, and Fred Bayerdoerfer, \$2,000, for money loaned. Mary Ubele is a sister of Mr. Bayerdoerfer who lives in Germany. Fred Bayerdoerfer is his brother, a retail jeweler, at 428 Fourth Ave.

Assignee Connelly estimates the liabilities at about \$20,000 and the assets between \$12,000 and \$15,000. The creditors number about 25, and are almost all in New

York. Mr. Bayerdoerfer attributes his failure to the poor business of the past two years.

John J. Donnelly, the assignee, stated that the schedules would be filed yesterday and that the stock and outstanding accounts will be converted into cash as quickly as a due regard to creditors' interests will admit. Earnest efforts made to effect a compromise settlement, he said, have failed, although the fullest investigation and examination of the assignor's effects and affairs were invited and have been made by creditors representing over one-half of the liabilities.

### A Spectacle Swindler Comes to Grief in Columbus, O.

COLUMBUS, O., Jan. 14.—The home of Mrs. Wilhelmina Schart was the scene, a few days ago, of an exciting episode. About ten days ago a spectacle peddler, claiming to be in the employ of H. Cole, optician, had called at the house and traded the old lady a pair of gold plated spectacles worth about a dollar for a pair of gold spectacles worth \$6, receiving \$2 to boot. As soon as the trade became known to the men at the house, they began a sharp lookout for the peddler. He was captured after a lively chase. He was taken back to Mrs. Schart's house and Mr. Cole was called, as the man persisted in claiming to be in that gentleman's employ. When Mr. Cole arrived an exciting scene occurred.

He denied any transactions with the peddler, but let him off on the understanding that Mrs. Schart be reimbursed and that he leave town at once. The man only had a portion of the amount due the old lady, and he left his watch and stock of spectacles while he went home to get more money.

Mr. Cole stated that the man's name is Isaac Schwartz and that Schwartz has caused him considerable trouble. Some times Schwartz represented that his name was Cole, at other times that he owned the store and that Mr. Cole worked for him, and at other times that he worked for Cole.

### St. Joseph.

G. H. McKelvey offers his stock for sale, as he wishes to close out his entire jewelry stock and will put in a large optical stock.

J. H. Tiefenburn, a manufacturing jeweler, who has been here for a number of years, has sold out his tools and machinery to W. R. Tilley & Co. Mr. Tiefenburn has left for St. Louis, where he expects to reside.

J. W. Richardson & Co., 200 Broadway, New York, have just issued a very hand some and complete illustrated catalogue of the solid gold emblems, pins, lapel buttons and charms manufactured by them. It is bound in blue cloth, and will be recognized by the jobbing trade as the "Blue Book" *par excellence* of this branch of the jewelry trade.

### Last Week's Arrivals.

**THE CIRCULAR** has perfected arrangements for obtaining the names and hotel addresses of all the latest buyers visiting New York, and each day posts in its office, 189 Broadway, a bulletin which every member of the trade is cordially invited to copy.

The following out-of-town dealers were registered in New York during the past week: L. Heller, Chicago, Ill., Belvidere H.; O. N. Shurly, Chicago, Ill., Astor H.; S. Lesser, Syracuse, N. Y., Imperial H.; J. Karr, Washington, D. C., Gilsey H.; J. Becker, J. G. Myers & Co., Albany, N. Y., Grand H.; B. Ginsberg, Boston, Mass., Normandie H.; M. C. Ellis, Toronto, Ont., Astor H.; C. W. Bixler, Easton, Pa., Coleman H.; B. V. Arnstine, Cleveland, O., Astor H.; E. A. Eisele, Buffalo, N. Y., Imperial H.; G. Hoyer, York, Pa., Sinclair H.; D. W. Janowitz, Baltimore, Md., Sturtevant H.; M. Streicher, Chicago, Ill., Astor H.; M. Hirsch, Chicago, Ill., Stewart H.; F. Knowlton, Worcester, Mass., Murray H.; W. Jenkins, Richmond, Ind., Metropole H.; H. W. Gubbins (Edson Keith & Co.), 96 Spring St.; G. A. Gay (Brown, Thompson & Co.), Hartford, Conn., 120 Franklin St.; A. L. Warner, Buffalo, N. Y., Imperial H.; S. Guggenheim, Buffalo, N. Y., Imperial H.; C. G. Fogg (Shepard & Co.), Providence, R. I., 54 Franklin St.; L. A. Lallance (J. S. Naylor & Co.), Wheeling, W. Va., 101 Franklin St.; A. Kingsbacher, Pittsburgh, Pa., Astor H.; A. G. Schwab, Cincinnati, O., Plaza H.; H. Hoffa, Washington, D. C., Broadway Central H.; John C. Dueber and W. A. Moore, Canton, O., Astor H.; M. Wendell, Chicago, Ill., Imperial H.; G. Weil, Danville, Pa., Metropolitan H.; A. Dilsheimer, Philadelphia, Pa., Astor H.; S. Cerf, Pittsburgh, Pa., Astor H.; H. E. Kirstein, Rochester, N. Y., Imperial H.; A. and E. Sickles, Philadelphia, Pa., Imperial H.; J. and R. Kasper, Chicago, Ill., Imperial H.; A. E. Shader, Chicago, Ill., Astor H.

W. & S. Blackinton have a number of excellent new things, and a few of them are well shown up on another page. Business with this house is booming and fifty additional hands have been given permanent quarters on the ground floor of the firm's building. Dealers are each day learning to appreciate the line more and more.

The following unsolicited letter of commendation was received Jan. 8th by the Self Winding Clock Co., third floor Columbus Memorial building, Chicago:

CHICAGO MANUAL TRAINING SCHOOL,  
MICHIGAN AVE. AND 12TH ST.  
CHICAGO, Jan. 8, 1895.

Self Winding Clock Co.:

DEAR SIRS—Our self winding clock attends strictly to business year after year. It is a great comfort, needing attention only about once in two years.

Very truly yours,

H. H. BELFIELD, Director.

### Imports and Exports for November, 1894, and the Preceding Eleven Months.

WASHINGTON, D. C., Jan. 14.—The summary statement of imports and exports for the month ending Nov. 30, 1894, and the eleven months ending the same date, compared with the corresponding periods of 1893, has been issued, and contains the accompanying figures relative to the jewelry trade:

Two immense steel safes were demolished, dynamite being used on one to blow the door off, which was found lying at the other end of the office, and the outer door of the other was pried off, the inner box being unlocked. The safes were rifled of everything except the books, papers and checks, the robbers securing a rich haul of diamonds. They did not stop to clean up the debris, but left as they entered by

	NOVEMBER		OCT.	ELEVEN MONTHS ENDING NOVEMBER.	
	1894.	1893.	1894.	1894.	1893.
<b>IMPORTS.</b>					
Diamonds and other precious stones, rough and uncut, including glaziers' and engravers' diamonds, not set, and jewels to be used in the manufacture of watches.	\$11 431	\$4,0 491	\$5 780	\$829 464	\$773 087
Clocks and parts of.	33 430	10 176	45 146	145 141	162 271
Watches, and parts of, and watch materials and movements.	96 164	110 891	115 601	889 390	1 372 788
Jewelry, and manufactures of gold and silver.	83 691	58 057	64 733	402 776	688 526
Precious stones, n. e. s. and imitations of, not set.	659 753	180 311	523 626	6 379 542	9 767 619
<b>EXPORTS.</b>					
Clocks, and parts of.	81 371	87 207	85 488	813 999	847 610
Watches, and parts of.	35 7 0	37 248	32 426	290 886	363 916
Jewelry, and manufactures of gold and silver.	61 600	76 543	44 045	651 654	936 675
Plated ware.	5, 869	37 812	27 732	259 099	317 657
<b>EXPORTS OF FOREIGN MERCHANDISE.</b>					
Diamonds and other precious stones, rough and uncut, etc.				2 220	355
Clocks, and parts of.	25			343	654
Watches, and parts of, etc.		7	14	48 434	444
Jewelry, and manufactures of gold and silver.	195	5 044	2 192	51 684	16 807
Precious Stones, n. e. s. and imitations of, not set.	61	160		4 325	1 328

### A Quartet of Daring Burglars Get in Good Work in Providence.

PROVIDENCE, R. I., Jan. 12.—Robbers, with an evident knowledge of the fitness of things and beyond doubt experts of the first class, got into the third story of the Bowen building, 107 Friendship St., Monday night, and cleaned out three manufacturing jewelry concerns at one stroke, leaving nothing but a Brownie pin. The amount of jewelry stolen aggregates nearly \$7,500, even gold scraps and cheap ornaments being taken, together with an entire stock of gold rings and several diamonds,

means of the fire escape at the back of the building.

The firms robbed are Wildpret & Saacke, manufacturers of solid gold rings; S. C. Shurtleff & Co., stone and pearl setters and repairers, who had a considerable stock belonging to other manufacturers; and A. V. Blake, manufacturer and salesman, who lost the contents of a sample case containing pins and brooches.

Mr. Wildpret, the last to leave the shop Monday evening, remained there until past 7 o'clock, straightening out the orders for the following day's work and then carefully

secured the doors and windows, previous to departure. He was the first to arrive the following morning and as he entered the office one glance was sufficient to disclose the startling fact that the place had been visited during the night. He opened the door leading to the workshop. Here everything was in the utmost confusion. Stools were overturned, the benches stripped of all the glittering stock, which looked so tempting the night before, and tools thrown about in a promiscuous disorder. Not even a scrap of gold was left. A glance at the broken window revealed the secret of the robbers' entrance. They had gained access to the fire escape by means of a board placed against the building and clambered up to the third story, the first which seemed to display sufficient quantities of the tempting merchandise to entice their crafty skill. The second story is vacant, and the first floor is occupied by Vennerbeck & Clase.

As soon as Messrs. Shurtleff and Blake arrived they set about to calculate their losses by the night's depredations. Wildpret & Saacke concluded that between \$4,000 and \$5,000 would recompense them for the loss of gold rings and scraps. S. C. Shurtleff estimates his loss at about \$1,000, embracing about a dozen diamonds and considerable gold and silver. A. V. Blake's loss is placed at about \$500.

### First Annual Meeting of the American Optical Jobbers' Association.

The first of the annual meetings of the American Optical Jobbers' Association commenced yesterday morning in one of the parlors of the Astor House, New York. The firms represented were: Queen & Co.; D. V. Brown; McIntyre, Ulmer & Co.; Geneva Optical Co.; Globe Optical Co.; E. Kirstein's Sons Co.; F. A. Hardy & Co.; Winsted Optical Co.; Julius King Optical Co.; Spencer Optical Mfg. Co.; Johnston Optical Co.; Sussfeld, Lorsch & Co.; and Levy, Dreyfus & Co. The only members not represented were L. Black & Co., and Chambers, Inskeep & Co.

Dr. Julius King presided, while Geo. Johnston, the secretary and treasurer, filled his official post. This is the first meeting since the organization of the Association last August and it was understood that arrangements would be perfected for carrying out fully the object of the Association, namely the mutual protection of the members against irresponsible customers and those who are habitually slow pay.

The American Optical Jobbers' Association was formed Aug. 6th, at Niagara Falls. The officers are: President, Julius King, of the Julius King Optical Co.; vice-president, F. A. Hardy, of F. A. Hardy & Co.; secretary and treasurer, Geo. Johnston, of the Johnston Optical Co.; directors, J. E. Spencer, of the Spencer Optical Mfg. Co., and H. E. Kirstein, of E. Kirstein's Sons' Co.

### Providence.

P. H. Richardson, formerly of Richard Robinson & Co., has started in business at 277 Westminster St.

Henry Read, who has been in the manufacturing business at 40 Potter St., for the past 15 years, has retired from business.

Isaac B. Lawton and wife, and Charles E. Lawton, of Central Falls, left last week for a three months' visit to Los Angeles, Cal.

Mr. Fisher, western representative for the Kent & Stanley Co., has been visiting the factory the past week, preparing his sample line for the season.

Albert Wilson for more than a decade in the employ of William M. Fisher & Co., of Attleboro, has entered the employ of Hamilton & Hamilton, Jr.

Francis W. Lincoln has sold his interest in the firm of S. T. Lincoln & Co. to F. A. Lincoln, and the business will be continued at the same place under the old name.

J. A. Flomerfelt, of J. A. Flomerfelt & Co., New York, has been in this city the past week on business in connection with the defending of certain patent rights which he claims are being infringed upon.

Andrew G. Lorimer, an optician of this city, was stricken with apoplexy at his home 146 Chestnut St., Wednesday afternoon and died almost instantly. He was 52 years of age and a member of several secret societies.

Alfred Williams has placed a chattel mortgage covering stock, lathes, dies, office furniture, etc., on fifth floor of the Fitzgerald building, to Wm. H. Miller, for \$600, and a second mortgage on the same property to Nathan H. Read, Attleboro, Mass., for \$1,400.

Vice-President Robinson, of the Gorham Mfg. Co., has presented to the Providence Athletic Association, a handsome loving cup of pottery with silver handles fastened by two rims of silver about the cup, as a prize in the whist tournament. The design is one of the Gorham's latest.

The directors elected at the recent annual meeting of the Manufacturing Jewelers' Board of Trade have organized with Dutee Wilcox as president; William R. Dutemple and Major Everett S. Horton as vice-presidents; Marcus W. Morton as secretary; Hoffman S. Dorchester as treasurer; and George E. Luther, Walter S. Williams and John M. Buffinton as finance committee.

Among the guests at the Narragansett Hotel the past week were Nathan Cohen, New York; J. M. Silver, New York; W. H. Kirby, buyer for the Pittsburgh Dry Goods Co., Pittsburgh, Pa.; and Sol Cerf, Sol Cerf & Co., Pittsburgh, Pa. The latter was formerly with M. Bonn & Co., and has been in this vicinity purchasing stock with which to start in business for himself.

At the organization of the City Council, last week, the following jewelers were appointed on committees: Councilman Horace

K. Blanchard on committee on Claims and Lamps; councilman George L. Vose on Highways and Railroads; councilman George H. Wood on Lamps and Sewers; councilman John L. Remlinger on Police and Parks; alderman Edward G. Burrows on Police, Poor Department, Streets and Pending Suits.

Some fifteen months ago H. C. Whittier & Son, of this city, made an assignment, but afterwards made a settlement with their creditors on a basis of 33 per cent. in several notes. As these have matured they have been met promptly, and on Tuesday last the final obligation, one day previous to its maturity. The past year has been a very good one with this firm, the holiday trade being exceptionally good.

During the past week the various banking institutions in this city have held their annual meetings and elections of directors. A glance at the following will prove that the manufacturing jewelers find time to devote themselves to other interests than the jewelry. Among the directors elected are: Dutee Wilcox, of National Bank of Commerce; William T. Barton, of Old National Bank; John Shepard, Jr., of Second National Bank of Providence; John McAuslan, of the Rhode Island National Bank; Beriah Wall, John S. Palmer and Sylvester G. Martin, of the National Eagle Bank; Isaac M. Potter, of Commercial National Bank; Silvanus M. Lewis, Steven M. Knowles and Jesse B. Sweet, of Fifth National Bank of Providence; Charles H. George, John M. Buffinton and Charles Sidney Smith, of Roger Williams National Bank; Edwin Lowe, Charles F. Irons, Englehart C. Ostby and Arthur E. Austin, of Citizens Savings' Bank; John McAuslan and Charles H. George, of Mechanics' Savings Bank; John S. Palmer

and Dutee Wilcox, of City Savings Bank; John McAuslan of the Roger Williams Savings Fund and Loan Association; Stern Hutchins, of the Industrial Trust Co.

### A Simple Cheap Watch.

RECENTLY it was mentioned in some journals of the trade that S. Schisgall, 301 E. 17th St., New York, had applied for a patent on a radically new watch. The patent has been granted, and Mr. Schisgall, who has been the superintendent of the Ingersoll Watch Co.'s factory, has severed his connection with this firm, and is endeavoring to find a capitalist with \$10,000 to establish a new factory to manufacture his watch.

Mr. Schisgall's object was to provide a time-piece, the construction of which would combine simplicity, novelty and accurate time-keeping qualities, which can be produced in large quantities with a small outlay for machinery, and at a very low cost. With these points in view Mr. Schisgall employs an ordinary train work, all parts of which are made exclusively by die work. The pinions are lantern. The combination of wheels and pinions which in an ordinary watch comprises the stem winding mechanism is entirely dispensed with in this watch.

A common lever fulcrum opens the barrel arbor with a click adapted to engage the ratchet wheel. This is the entire winding mechanism. The case of the watch has a slot through which the winding lever extends.

The inventor is convinced that there is a great popular demand for a very cheap watch, and he has devised the mechanism here described to supply it.

# 1895



# Novelties, Smart, Original.



# BACHRACH & FREEDMAN, SILVERSMITHS,

New York, Chicago and San Francisco.

# CLASSIFIED INDEX TO ADVERTISEMENTS.

All Advertisements are entitled to one insertion under proper heading. Extra insertions, \$6.00 per annum.  
Extra Headings, \$12.00 per annum.

<b>Art Pottery, Bric-a-brac, Etc.</b>	Page.	<b>Diamond Cutters.</b>	Page.	<b>Ring Makers.</b>	Page.
Bing, Ferdinand & Co., 106 Grand St., N. Y. . .	40	Fox Bros. & Co., 68 W. 4th St., Cincinnati, O. . .	33	Bowden, J. B. & Co., 192 Broadway, N. Y. . . . .	43
Hinrichs & Co., 29 & 31 Park Place, N. Y. . . . .	43	Oppenheimer Bros. & Veith, 35 Maiden Lane, N. Y. . . . .	10	<b>Safes.</b>	
Straus, L. & Sons, 42 to 48 Warren St., N. Y. . .	39	Randel, Baremore & Billings, 29 Maiden Lane . .	11	Mosler, Bahmann & Co., 518 B'way, N. Y. . . .	39
<b>Assayers &amp; Refiners.</b>		<b>Diamond Polishing Mills.</b>		<b>Sample Trunks.</b>	
Rathbone, J., 1-9 Mathewson St., Providence, R. I. . . . .	43	Arthur Co., The, 86 John St., New York. . . . .	44	Crouch & Fitzgerald, 161 Broadway, N. Y. . . .	5
U. S. Smelting & Refining Works, 25 John St., N. Y. . . . .	44	<b>Emblems.</b>		<b>Show Cases.</b>	
<b>Auctioneers.</b>		Richardson, J. W. & Co., 200 Broadway . . . . .	2	Smith, B. & W. B., 220 W. 29th St., N. Y. . . .	44
Boyle, Davis & Goodman, 63 5th Ave., N. Y., 611 Pennsylvania Ave., Washington, D. C. . . .	36	<b>Enamelers.</b>		<b>Silver Plated Ware.</b>	
Comrie, A. J., 22 John St., N. Y. . . . .	43	Wild, S. S. & Son, 179 Eddy St., Providence, R. I. . . . .	5	Pairpoint Mfg. Co., New Bedford, Mass. . . . .	5
Fechner, St. Clair, 612 Pennsylvania Ave., N.W., Washington, D. C. . . . .	43	<b>Fine Stationery.</b>		The Wm. Rogers Mfg. Co., Hartford, Conn. . .	40
H. M. Rich & Co., 21 School St., Boston, Mass. . . . .	5	Parsons & Greene Co., 18 Murray St., N. Y. . .	5	Webster. G. A., Chicago, Ill. . . . .	33
<b>Badges, Medals, Etc.</b>		<b>Gold and Rolled Plate Jewelry.</b>		<b>Sterling Silver Novelties.</b>	
Stockwell, E. R., 19 John St. N. Y. . . . .	40	Foster & Bailey, Providence, R. I. . . . .	3	Codding Bros. & Heilborn, North Attleboro Mass. . . . .	42
<b>Bicycles.</b>		<b>Gold Jewelry.</b>		Hagan, White & Co., 243 W. 23d St., N. Y. . .	43
Keating Wheel Co., Holyoke, Mass. . . . .	15	Aikin, Lambert & Co., 19 Maiden Lane . . . . .	39-40	<b>Sterling Silverware.</b>	
<b>Book Marks, Sterling Silver and Gold.</b>		Carter, Sloan & Co., 15 Maiden Lane, N. Y. . .	11	Bachrach & Freedman, 1 & 3 Union Sq., N. Y. .	27
Stone Bros., 535 Broadway, N. Y. . . . .	39	Greene, Geo. F., 111-113 Point St., Providence, R. I. . . . .	2	Fuchs, Ferd. & Bros., 808-810 Greenwich St., N. Y. . . . .	42
<b>Chains.</b>		<b>Horological Schools.</b>		Knowles, J. B. & S. M. Co., Silversmiths' Hall, Union Square, N. Y. . . . .	40
W. & S. Blackington, Attleboro, Mass. . . . .	20	Parson's School for Watchmakers, Peoria, Ill. . .	33	Shiebler, G. W. Co., 179 Broadway, N. Y. . . .	37
<b>Clocks, French, English and American.</b>		Philadelphia College of Horology, 623 Heed Building, Phila., Pa. . . . .	39	Towle Mfg. Co., Newburyport, Mass. . . . .	40
Jacques, Chas., Clock Co., 22 Cortlandt St., N. Y. . . . .	44	<b>Jobbers, Watches, Diamonds, Etc.</b>		Wallace, R. & Sons Mfg. Co., 3 Park Place, . .	6
Joliet Electric Mfg Co., Joliet, Ills. . . . .	33	Aikin-Lambert Jewelry Co., 19 Maiden Lane . .	39-40	Wood & Hughes, 16 John St., N. Y. . . . .	44
Self-Winding Clock Co., 26 Broadway, N. Y. . .	44	Myers, S. F. & Co., 48 Maiden Lane, N. Y. . . .	44	<b>Tool Manufacturers and Dealers.</b>	
<b>Cut Glass.</b>		<b>Musical Boxes.</b>		American Watch Tool Co., Waltham, Mass. . .	39
Clark, T. B. & Co., 860 Broadway, N. Y. . . . .	39	Jacot & Son, 39 Union Square, N. Y. . . . .	39	Moseley & Co., Elgin, Ill. . . . .	33
<b>Diamond &amp; Precious Stone Importers.</b>		<b>Ophthalmic College.</b>		Mossberg Wrench Co., Attleboro, Mass. . . . .	4
Cottier, C., & Son, 14 Maiden Lane, New York . .	44	Chicago Ophthalmic College, Chicago, Ill. . . .	33	Oliver, W. W., Buffalo, N. Y. . . . .	44
Disselkoben, John N., 19 E. 16th St., N. Y. . .	11	<b>Optical Goods.</b>		<b>Trunks and Traveling Bags.</b>	
Falkenau, Oppenheimer & Co., 40 Maiden . . .	44	Geneva Optical Co., Chicago, Ills. . . . .	33	Crouch & Fitzgerald, 161 Broadway, N. Y. . . .	5
Hedges, Wm. S. & Co., 170 Broadway, N. Y. . . .	10	Queen & Co., Philadelphia, Pa. . . . .	44	<b>Watch Importers.</b>	
Kahn, L. & M. & Co., 172 Broadway, N. Y. . . .	44	<b>Pens, Pencils, etc.,</b>		Hyde's, J. E., Sons, 22 Maiden Lane, N. Y. . .	40
Kipling, R. A., Hays Bldg., N. Y. . . . .	10	Aikin, Lambert & Co., 19 Maiden Lane, N. Y. .	39-40	Mathey Bros., Mathez & Co., 21 & 23 Maiden Lane, N. Y. . . . .	37
Keller, Ettinger & Fink, 24 John St. . . . .	37	<b>Photo-Miniature.</b>		<b>Watch Keys.</b>	
Smith, Alfred H. & Co., 182 Broadway, N. Y. . .	10	Favre Leon, 107 East 26th St., N. Y. . . . .	42	Clark, A. N., Plainville, Conn. . . . .	44
Tannenbaum, L., & Co., cor. Maiden Lane and Nassau St., N. Y. . . . .	19				

## Special Notices.

Rates 75c. per insertion for notices not exceeding 3 lines (25 words); additional words 2 cents each. If answers are to be forwarded, postage stamps must be enclosed. Two insertions, 15 per cent. off; three insertions, 20 per cent. off; four insertions or more, 25 per cent. off. Payable strictly in advance. Display cards on this page will be charged at \$2.00 per inch for first insertion, subject to same discount as above for subsequent insertions.

Under the heading of **Situations Wanted** on this page advertisements will be inserted for **One Cent a Word**. This offer refers to **Situations Wanted only**. Payable strictly in advance. If answers are to be forwarded, postage must be enclosed.

## Situations Wanted.

*Notices under this heading ONLY are charged at one cent a word, payable strictly in advance. If answer are to be forwarded, postage must be enclosed.*

**BY** experienced watchmaker, salesman and engraver, competent to take charge. Address Parker, Lock Box 401, Madison, O.

**ENGRAVER** and salesman desires position at once. Middle States preferred. Salary \$16. Reference given for character and ability. Address Commerce, care JEWELERS' CIRCULAR.

**BOOKKEEPER**, absolutely reliable and competent to take charge of office, credits and collections, desires to make a change: for number of years in similar position in watch and diamond line; excellent references. Address Amiable, 170, Care JEWELERS' CIRCULAR.

**YOUNG MAN**, 19 YEARS, WOULD LIKE A POSITION WITH A JEWELRY CONCERN WHERE HE CAN ADVANCE HIMSELF. EXCELLENT REFERENCES. ADDRESS OFFICE, CARE JEWELERS' CIRCULAR.

**FIRST-CLASS** watchmaker, 18 years' experience in fine and complicated work and adjusting of high grade watches, desires permanent position with important firm, appreciating good work. High wages expected. Address Adjuster, care of JEWELERS' CIRCULAR.

**A FIRST-CLASS** watchmaker would like position after January 1st. Full set of tools. References if required. Address Whitcomb, care of JEWELERS' CIRCULAR.

**HAVING** an extended acquaintance with both the wholesale and retail trade throughout the west, I should like to form a connection with some manufacturing jeweler as traveling salesman; fine goods preferred; salary moderate. Address Traveler, care JEWELERS' CIRCULAR.

**WANTED**, by a man of 28 years, a position as salesman in a wholesale or retail jewelry house; 12 years experience. References. Energetic, JEWELERS' CIRCULAR.

**A YOUNG** salesman having a large acquaintance in the jewelry trade wishes a position with moderate salary or commission. All references given. F., JEWELERS' CIRCULAR.

**SITUATION WANTED** to finish trade: three years' experience; no bad habits. Best references. Address P., Box 290, Collinwood, O.

**SITUATION WANTED** by a young man of 29, as traveling salesman in a jewelry house. Cheap jewelry preferred. Command a good trade in New York State and the east. Address D. M. C., JEWELERS' CIRCULAR.

**I WISH** to represent a manufacturing jeweler or jobber in my New York office. Finest location; excellent references. Address Maiden Lane, care JEWELERS' CIRCULAR.

**WANTED**.—A steady position by a 1 engraver in lettering, monos, etc. With best references or samples, if required. Address A., 1202 K. St., N. W., Washington, D. C.

**POSITION**; A 1 American watchmaker; expert engraver. Elegant bench and tools. Quarter century experience in city trade. Married. Good address; reliable. State wages paid. Address Eastern, care carrier No. 4, Newton, Kan.

**A FIRST-CLASS** traveling salesman, with established trade, wants line of sterling for New York or New England. All references. Address B. M., JEWELERS' CIRCULAR.

**WANTED**, position by optician and watchmaker. Can engrave and do jewelry jobbing. Have lathe, tools, trial case, etc. South or west. Best references. J. R., care JEWELERS' CIRCULAR.

**A YOUNG** man as salesman. Excellent trade in New York city and vicinity, desires to change his position. Can furnish best of reference. Would also take office position. Address Salesman, JEWELERS' CIRCULAR.

## Help Wanted.

**WANTED**—A TRAVELER WELL ACQUAINTED WITH NEW ENGLAND JEWELRY TRADE. ONE WHO HAS HANDLED SILVER PLATED WARE. ADDRESS M., CARE JEWELERS' CIRCULAR.

**WANTED**—Experienced traveling salesman to carry a leading and well-known line of spectacles and eyeglasses. Samples easily carried. Liberal commission. Address Optics, care JEWELERS' CIRCULAR.

## For Sale.

**THE** greatest bargain ever offered.—The oldest established jewelry store in a railroad center of 1,400. Send me your address and I will give you full information. Address Watch Inspector, care JEWELERS' CIRCULAR.

**FOR SALE**—Well established jewelry and optical business in best business city of the south; population 30,000; only three other stores; established over five years and has been well advertised; best located store in city, nice size and moderate rent; have carried stock of \$6,000 to \$7,000; inventories now about \$4,000; could be reduced to suit purchaser; fixtures, etc., about \$1,200; sales have run from \$8,000 to \$10,000 and profits \$3,300 to \$5,800 per annum; stock consists of American watches, diamonds and a general line of jewelry, which is all in good shape and desirable goods; have made specialty of optical business and this alone pays \$1,800 per annum; would like to correspond with parties having cash, or who could give good paper and to whom I will show my books, etc., to verify my statements; only reason for selling is, am compelled to engage in out-door business on account of my failing health. Address E. A. Williams, 1005 Main St., Lynchburg, Va.

**FOR SALE**, at a bargain, jewelry store, established 18 years, 10,000 population. Easy terms. Write at once. Lock Box 133, West Gardner, Mass.

**FOR SALE OR EXCHANGE**, electric engraving machine, cost \$160. For phonograph or graphophone, musical goods or watches. What have you for exchange? Address Tupper, care JEWELERS' CIRCULAR.

**FOR SALE**, by the executors of an estate, a partnership in a leading jewelry house, commanding the finest trade, and well located in New York city. Address V., JEWELERS' CIRCULAR.

**FOR SALE** cheap, for cash, or exchange for improved real estate, a fine jewelry store, established 20 years, in a southern New England city, convenient to seaside hotels, whose patrons bring a good summer trade. The owner has other business and resides out of town. The store is run by a manager. Address C. A. B., care JEWELERS' CIRCULAR, 189 Broadway New York.

**PAWNBROKER'S** business in New York city, established 20 years, for sale; retiring from business; splendid opportunity; invite closest inspection. Address Chance, care JEWELERS' CIRCULAR.

## To Let.

**TO LET**—52 Maiden Lane, store and basement; also two upper floors. Apply Louis Herzog, on the premises.

## Miscellaneous.

**WOULD** like to negotiate in person with a reliable sterling silver manufacturing house, or a jobber in silver and kindred goods, with a view to becoming their agent, and making my store a depot for their goods. Mine is the handsomest jewelry store in Newark, N. J., located in a fire and burglar proof building; could devote a large and elegant wall case, and 20 feet of show case for display of goods; I deal principally with the better class of people; leading wholesale jewelers as references. Address Business, care JEWELERS' CIRCULAR.

**WATCHMAKING** thoroughly taught by an experienced mechanic, no crowded school, but a limited number taken; charges reasonable; actual work. For particulars, etc., address M. E. Harmstead, 709 Sansom St., Philadelphia, Pa.

## Business Opportunities.

**PARTNER WANTED**—For a favorably and well-known manufacturing jeweler, with a first-class trade and good line of staple gold goods; one to act as salesman and to furnish \$6,000 to \$8,000; said amount wanted to increase the business. For particulars address C. S. Carter, P. O. Box 1228, Providence, R. I.

## WHEEL CUTTING.

We make a specialty of Wheel Cutting, Demagnetizing and Watch Repairing for the trade. Complete plant. Send for price list.

**THE WINSLOW & PENNEY CO.**  
608 Masonic Temple, - CHICAGO.

The Jewelers' Circular,

1869 = 1895,

Twenty-Six Years.

OLDEST,  
BEST,  
BRIGHTEST,  
NEWSIEST.

\$2.00 For One Year.

OR

SEND \$2.50

FOR A YEAR'S SUBSCRIPTION  
WITH A COPY OF

Workshop  
Notes.

## News Gleanings.

Sharp & Studer, Montreal, Que., have dissolved.

S. W. Brown, Beatrice, Neb., has given a mortgage for \$250.

Fred. Brodizaard, Omaha, Neb., has given a bill of sale for \$400.

J. O. Dudley will open a new jewelry store in Colchester, Ill.

Annie E. Smith, Norfolk, Va., is advertising a sale to close out.

F. W. Duke, Fort Dodge, Ia., has given a chattel mortgage for \$75.

R. M. Kearn & Bro., Detroit, Mich., have given a bill of sale for \$1.

J. P. Oliver, Hearne, Tex., recently suffered a loss of \$500 by fire.

McEwan & Freeman, Huntington, Tenn., have sold out to A. B. Fry.

Van Bergh Bros., Rochester, N. Y., have sold out to James Vernuisse.

G. F. Bauch, Fort Madison, Ia., has given a realty mortgage for \$3,000.

F. S. Fisher, Sidell, Ill., has conveyed realty to the amount of \$4,000.

The store of C. M. Schreiber, Greenville, Tex., has been damaged by fire.

Wm. Rolleston, St. Augustine, Fla., has given a chattel mortgage for \$500.

F. B. Lewis & Co., Cleveland, O., have given a chattel mortgage for \$2,000.

A. M. Cling, Danville, Pa., has moved his stock and fixtures to Duncannon, Pa.

Henry L. Meyers, Lynn, Mass., Monday made an assignment to Arthur F. Foster.

E. S. Rose, Joplin, Mo., has made an assignment and gave a mortgage for \$343.

F. W. Hey has opened a jewelry repairing shop in Hiner's floral establishment, Rockford, Ill.

E. H. Wetherhold, formerly at 106 N. 7th St., Allentown, Pa., has removed to 738 Hamilton St.

H. E. Hemingway, Brandon, Vt., will soon move his jewelry business into another store in that town.

Sheriff Wolfe visited Bethlehem, Pa., Jan. 8th, and he posted a new sale bill on Rauch's jewelry store.

F. C. Sands, jeweler, Sag Harbor, N. Y., has made an assignment, his mother being the preferred creditor.

Some of the toughs of the town smashed one of the windows of Cletus Keller, Luzerne, Pa., a few days ago.

John E. Thomson, Mechanicsville, N. Y., has removed his stock to a large store in the First National Bank block.

B. Petkyn has appointed H. Rothstein his agent to conduct his jewelry business at 825 E. Broad St., Brocton, Mass.

Sylvester Engle, Hazleton, Pa., has transferred his business to his son, Sylvester, Jr., who has had the management of it for some time.

J. O. Farris, Marion, Ind., has moved his

stock of optical goods to Wabash, Ind., and will open a store in the postoffice room.

The Dueber Watch Case Mfg. Co.'s works, Canton, O., resumed operations Jan. 7, with a full force in nearly all departments.

Albert G. Bedford, of R. H. Bedford & Son, Ionia, Mich., was recently united in marriage to Miss Grace S. Long, of the same city.

The marriage of Charles S., son of Edward Coriell, jeweler, Portsmouth, O., to Miss Od'ie May Guilkey, will take place to-day, Jan. 16.

John M. Caldwell, jeweler, Bryan, Tex., has filed a deed of trust, naming T. B. Collins trustee. Liabilities about \$3,000; assets about \$4,000.

M. J. Davidow, of the jewelry firm of Davidow Bros., 217 Lackawanna Ave., Scranton, Pa., is in Pittsburgh, where he intends opening a branch of the Scranton store.

Frank J. Drove, jeweler, Springfield, O., made an assignment on the afternoon of Jan. 10. The assets and liabilities are not known. He says it was impossible to make collections.

The City Council of Maysville, Ky., have adopted an ordinance increasing the license for spectacle peddlers from \$35 a year to \$100 a year. This license is imposed to protect the dealers there.

The four story business block, northwest corner of Market Sq., Williamsport, Pa., partially occupied by Bower Co., jewelers, has been sold. It is probable the jewelry firm will seek other quarters.

The jewelry store of C. A. Lindsey, Johnstown, Pa., has been closed by the sheriff on executions by Dr. E. L. Miller and other creditors. The claims against Mr. Lindsey aggregate several hundred dollars.

H. A. Gage, who has been conducting a jewelry store in York, N. Y., moved to Perry recently and opened an auction store. During the evening Morris Rosenbloom, of Rochester, appeared and seized the stock with an attachment.

O. H. Simpson, jeweler, with J. H. Hardick, Fairport, N. Y., was recently severely burned about the face. He was using the alcohol lamp, when for some reason unknown, it exploded, throwing some of the burning fluid in his face.

William Mason Boole, a jeweler, shot and killed himself in the store of his employer, John F. Beyerle, Reading, Pa., on the night of Jan. 7th. His body was found the next forenoon. The cause of the suicide, it is said, was marital troubles.

St. Clair Fechner, the live jewelers' auctioneer, opened a sale for S. C. Forschum, Nanticoke, Pa., on Jan. 15. He will run a sale for Wm. J. Tinthoff, Oil City, Pa., Jan. 24, and has sales in Nashville, Tenn., and Syracuse, N. Y., to follow.

Martin Eggers, one of the best known watchmakers in Louisville, Ky., died at his home, 215 Market St., a few days ago, of kidney trouble. He was 68 years of age, and went to Louisville from Hanover. He leaves a wife and six children.

Two men entered the jewelry establishment of J. Levinski, 407 Austin Ave., Waco, Tex., a few days ago, and after examining goods left. After they were gone it was discovered that a tray containing valuable diamonds was gone. No arrest has been made.

C. S. Apple, optician, Indiana, Pa., has purchased from William Young, of West Indiana, the Grove property on Philadelphia St. The sale includes only the dwelling. The price paid for the dwelling was \$4,000. Mr. Apple will take possession on April 1.

Confessions of judgments were filed last week by Wyllys N. Rudd, Rome, N. Y., who conducted a jewelry store. These are for \$6,952.68 and in favor of his father, Nathan S. Rudd, for money loaned on notes. Mr. Rudd's stock will be sold at public auction on Jan. 14th.

The store recently vacated by Marshall & Bragg, on Merchants Row, Rutland, Vt., is being refitted and newly papered. It has been leased to Brown & Hascall, jewelers, of West Rutland. They will move their stock of goods into the store as soon as it is refitted.

The general store of F. A. Barr, and the drug and jewelry store of A. J. Athay, Sparland, Ill., were robbed on the morning of Jan. 7th and \$1,500 worth of merchandise stolen. Entrance was effected through a back window, and the goods were carried away in a wagon.

In a destructive fire in Bradford, Pa., which started at 6.45 o'clock Sunday morning, at 99 Mechanic St., the business of Rothstein & Lippmann Bros., jewelers and pawnbrokers, was destroyed, the loss on building, stock, etc., being placed at \$15,000; insurance, \$4,000.

A party was in Iowa City, Ia., last week selling what he alleged to be Seth Thomas clocks. He sells on the instalment plan and disposes of his wares at a rate considerably lower than the bona fide Seth Thomas clock sells for. He was challenged by a local watch repairer, who offered to wager from 25 cents to \$5,000 with the salesman that the latter's clocks had no Thomas movement. The bet was not taken.

On the afternoon of Jan. 4, L. H. Wallace, jeweler, Salt Lake City, Utah, made an assignment for the benefit of his creditors to Willis Beardley. The total liabilities are \$11,000, and it is supposed, so far as present information goes, that the assets will about pay the liabilities. Hayden W. Wheeler & Co., New York, are preferred to the extent of \$7,284.65, and J. G. Raine, of Ogden, to the extent of \$170. The other creditors are not preferred.

**The Latest Patents.**

ISSUE OF JAN. 8, 1895.

**532,078. CLOCK-LEVEL.** WILLIAM J. MARSHALL, Desert, Tex.—Filed July 2, 1894. Serial No. 516,304. (No model.)

A clock level, consisting of the wall-plate A, provided with means for securing the same to the wall; arm braces B, their lower ends being secured to the outer face of the wall-plate A, their upper and horizontal ends provided with threaded perforations *b'*;

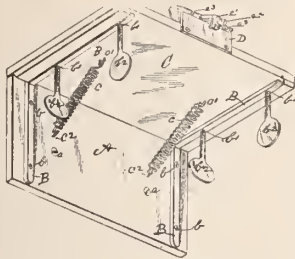

thumb screws *b*<sup>2</sup>, working in said threaded perforations, their upper ends slightly buried in the lower face of the shelf-plate C; shelf-plate C, resting on the upper ends of the thumb-screws *b*<sup>2</sup>; spiral springs *c*, securing said shelf-plate on the upper ends of said thumb screws, said shelf-plate adapted to be leveled by means of thumb-screws *b*<sup>2</sup>, and any suitable level or levels.

**532,135. LENS-MEASURING INSTRUMENT.** ROBERT H. BIEGEL, Denver, Colo.—Filed Feb. 3, 1894. Serial No. 499,044. (No model.)

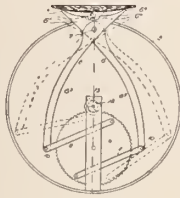

In a lens measuring instrument, the combination with a suitable case, of two movable parts crossed and suitably pivoted together at their point of intersection within the case, and having four contact points in the arc of curvature.

**532,229. COLLAR-BUTTON.** FRANK C. CRAW, South Norwalk, Conn. Filed Sept. 24, 1894. Serial No. 523,880. (No model.)

As an article of manufacture, a collar button and bosom supporter comprising a rigid plate curved to correspond approximately with the neck band of a shirt, and provided with a collar button of ordinary

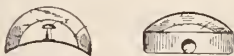

construction, and a rigid plate 4 which extends downward and outward therefrom and is adapted to lie under the upper end of the shirt bosom to prevent the bosom from falling in, the device as a whole acting to hold the collar, and to retain both neck band and bosom in position.

**532,288. SPECTACLE-CASE HOLDER.** ROBERT T. ROBERTS, La Harpe, Ill. Filed May 23, 1894. Serial No. 512,152. (No model.)

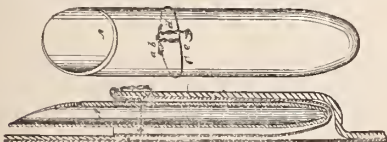

A spectacle case holder comprising two lengths of wire twisted together for part of their length and forming the hook like or U shape arm at the lower extremity of which the wires are pointed and bent

inwardly as at *e e*, the untwisted portions of the wire being oppositely bowed to form the clamp *d*, the extremities of the two wires being formed to interlock as shown at *a b*.

TRADEMARK **25,805. WATCHCASES.** DUEBER WATCH CASE MANUFACTURING COMPANY, Canton, Ohio. Filed Nov. 26, 1894.



*Essential feature.*—The representation of a shield with the word "DUEBER" and the letters "W. C. Co." Used since July 2, 1894.

**Pittsburgh.**

R. L. McWatty & Co. are busily engaged in selling out at auction.

Otto Heeren has been very ill during the past week, and is confined to his home.

M. Arnheim & Co., 941 Liberty St., have dissolved partnership, Mr. Goldsmith retiring.

I. Ollendorf has taken charge of W. Milchsack's store, and commenced an auction sale on Jan. 14.

Charles T. Ahlborn, taking advantage of the rise in the river, has gone to Cincinnati on a pleasure trip.

B. W. Hose, Wheeling, W. Va., has assigned, but the amount involved is not large. Mr. Hose expects to arrange affairs satisfactorily.

The store of Charles Stoupe, Turtle Creek, of the Greater Pittsburgh elect, was burned out last week, and part of his stock consumed.

The Atlas Jewelry Co. have entered judgment against W. H. Milchsack. Mr. Milchsack intends settling his affairs and going into business again.

Goddard, Hill & Co. have issued judgment against L. B. Ruff for \$292. John W. F. Ehlers has entered one for \$357, and S. M. Einstein against the same party for \$149.

Heeren Bros. & Co. and A. H. Gerwig are involved in the failure of A. F. Shutterly, Mt. Pleasant, Pa., whose executions aggregate some \$2,000. The sale has been postponed.

Among the buyers in town last week were: P. J. Manson, Jeannette; R. B. Fisher, Greensburg; F. H. Hayes, Washington, Pa.; H. H. Weylman, Kittanning; and C. L. Clark, Blairsville.

Travelers in Pittsburgh last week were: R. Hamilton, Hamilton & Hamilton, Jr.; E. T. Hopkins, Meriden Silver Plate Co.; Wm. W. Middlebrook, B. A. Ballou & Co.; Mr. Schwab, New Haven Clock Co.; W. R. Bristol, C. Rogers & Bros.; C. M. Dillon, Meriden Cutlery Co.; G. D. Munson, Wm. Rogers Mfg. Co.; Harry Osborne, Whiting Mfg. Co.; R. Wilcox, Rogers, Smith & Co.; W. H. Tarlton, Wightman & Hough Co.; F. V. Kennion, for John T. Mauran; Mr. Oakley, Thornton Bros.; B. A. Noble, Payton & Kelley; Geo. C. Booth, Hutchison & Huestis; I. C. Nicholson, Flint, Blood & Co.; H. J. Hildebrand, for H. C. Lindol.

**Newark.**

Mrs. Frieda Knapp, 374 Hunterdon St., last week reported to the police that her husband, age 27, had been missing since last Wednesday. She said he had been despondent on account of the impending foreclosure of a mortgage of \$3,000. Mr. Knapp is a jeweler.

On Jan. 12, the firm of Cory & Osmun dissolved by mutual consent. Both will continue in business as manufacturers of fine gold jewelry, the former, W. F. Cory, with his brother, John C. Cory, for six years factory foreman for Cory & Osmun, under the firm name of W. F. Cory & Brother, and the latter A. W. Osmun, with A. J. Parker, for many years with Riker Bros., under the name of Osmun-Parker Mfg. Co. The stock which Cory & Osmun had on hand has been divided between the two firms. The Osmun-Parker Mfg. Co. commence business Feb. 1st with office and factory at 338 Mulberry St., this city, and will make fine gold jewelry exclusively. W. F. Cory & Brother will do business at 27 Marshall St., this city. All accounts due Cory & Osmun should be remitted to Geo. W. Gore, 76 Columbia St., Newark.

**Syracuse.**

Herbert C. Watts, optician for Calvin S. Ball, left Saturday for a two weeks' vacation at his home in Ann Arbor, Mich.

Wm. Lesser, of A. Lesser's Sons, returned from New York Tuesday last and Simon Lesser, of the same firm, left on Thursday for a week's stay in the metropolis.

Mr. Hitchcock, of Hitchcock & Morse, left Wednesday for a four weeks' trip through Vermont, and F. J. Hollister is in northern Pennsylvania on a business trip for the same firm.

A. H. Rose, Auburn; N. G. Taylor, Weedsport; C. J. Fuller, Phoenix; G. N. Lucky, Baldwinsville; C. H. Fuller, Manlius; J. F. Orton, Canastota; and A. B. House, Orwell, were among the buyers in Syracuse last week.

The Trost jewelry shop on N. Salina St., was sold on mortgage foreclosure by Deputy Sheriff Cahill last week. The judgment was in favor of Caroline Muller against Catharine Trost, as executor of the estate of John Trost, for the sum of \$1,852.80. The property was purchased by the plaintiff for \$2,000.

The smiling traveling representative for 1895 is beginning to make his appearance in limited numbers in Syracuse. Alva J. Lasher, Whiting Mfg. Co.; L. E. Van Horn, Philipp Zellenka & Son; G. C. Booth, Hutchison & Huestis; J. M. Morrow, American Watch Case Co.; Mr. Ferre, O. W. Bullock & Co.; R. E. Kehl, F. H. Noble & Co.; A. G. Watts, Rogers & Brother; B. A. Noble, Payton & Kelley; Jay S. Budlong, Lord & Case; Mr. Hancock, Hancock, Becker & Co.; and Arthur Bradshaw, Meriden Britannia Co., were noticed in Syracuse the past week.

THE "WIND" TAKES ITS WAY!

# WESTERN SUPPLEMENT

## of THE JEWELERS' CIRCULAR

**Chicago Office: Room 517, Inter-Ocean Building.**

VOL. XXIX.

CHICAGO, WEDNESDAY, JAN. 16, 1895.

No. 25.

### Chicago Notes.

#### TRADE CONDITIONS.

The trade of the west for the season is entirely satisfactory. A number of bills of respectable size have been sold, many jewelers are patching up their stocks, and a generally healthy feeling prevails. The present business for the season is good and a consensus of opinion indicates the Spring trade will offer added encouragement. A gradual increase of sales has set in, which all the signs of the season indicate will be increased.

G. W. Flanders and wife, Marcellus, Mich., were in town several days.

Elmer A. Rich, manager for Alfred H. Smith & Co., is on a ten days' visit to New York.

Capt. P. H. Ray, U. S. A., will be the guest of O. W. Wallis at the jewelers' banquet on the 24th inst.

W. D. Searle, of Petoskey, Mich., will take a course of optics at the Chicago Ophthalmic College.

J. W. Forsinger, general watch inspector for western railroads, has returned from a brief visit to St. Paul.

Frank Barger, formerly of Woodstock, Barger & Hoefler, Kansas City, is in the city and is said to be considering locating here.

By a fire in an adjoining building the store of E. J. H. Hoyer, 26½ Clybourn Ave., was slightly damaged, and a large plate of glass in the front smashed in.

General Ruger, Captain Ray and Captain O. W. Wallis, all of whom entered the war from Wisconsin and are members of the Loyal Legion, will form a triumvirate of "vets" at the jewelers' banquet.

John W. Tyler, a jeweler on 43d St., near Drexel block, has signed a lease for a downtown store on Monroe St., in the Clifton House block, which he will occupy March 1. He was formerly of Tyler & Anderton, Dayton, O.

While conversing with THE CIRCULAR representative Thursday Wm. P. Mockridge, of the W. P. Mockridge Mfg. Co., received

the following telegram: "Frank Gutmann lost case and pays costs." The case was over a cuff holder made by Mr. Mockridge which Mr. Gutmann claimed was an infringement of patent rights held by him. Action was brought before the United States Circuit Court at Trenton, N. J., with the result outlined above. Gutmann's claim was for damages to the amount of \$20,000.

The New York Standard Watch Co. have on display at the Bicycle Exhibit at the Cavalry Armory a line of their "Standard" cyclometers, which are attracting much attention from wheelmen. The little instrument for measuring distance traveled weighs but four ounces, is as accurate in its working as a watch, of handsome appearance, and seems to fully meet the requirements at a low price. The exhibit is in space near the Armory entrance, and is in charge of E. T. Webbe, of the firm's New York cyclometer department.

Some time since C. M. Robertson, 216 Oak St., received a request from a woman customer for a hair chain mounting, which was to be a present to her lover. Mr. Robertson secured the mounting, but in the meantime the swain had proved faithless and the lady refused to take the article from the jeweler. Mr. Robertson thought he was entitled to some financial consideration for his trouble, but the lady indignantly swept from the store, and in slamming the door broke the plate glass it contained. The justice said "\$10 and costs" when the case was tried, charging her with "disorderly conduct." Only 75 cents was involved.

Chief of Police Farrell of Dayton, O., is doing effective work in unearthing the robbers who looted the Brethauer Watch & Jewelry Co.'s store in this city, recently, of \$2,000 worth of goods. About three weeks ago he sent to the firm a photo taken six years ago of a man he suspected. Mr. Brethauer, Jr., thought the picture was that of one of the men who assaulted him. A week ago Saturday the chief came here with a photo of the suspected party as he looks now. This was identified fully by Mr. Brethauer as his assailant. The man had been arrested in St. Louis, escaped with

his manacles and had been re-arrested at the workhouse. G. W. Brethauer, Jr., went to St. Louis and fully identified his man as the one whom he at the time called the "big one." When arrested in St. Louis, Smith alias a dozen names, had in his possession one of the stolen watches which he tried to throw away, but was detected. He was brought here Saturday and lodged in jail on a charge of "robbery by force." A pawnbroker named Henry Gallant, to whom Smith says he sold some of the goods, is under arrest in St. Louis.

In corroboration of reports of good business during the holidays throughout the west and that stocks were nearly depleted come the following out-of-town dealers with liberal orders for the season. The number arriving from other States is a most encouraging sign. The list: A. Brown, Momence, Ill.; G. S. Bauder, Elberon, Ill.; Geo. F. Beach, Valparaiso, Ind.; W. W. Denny, Aurora, Ill.; Eggerman & Son, Aurora, Ill.; M. Hedman, Table Grove, Ill.; J. F. Haehni, Aurora, Ill.; J. F. Ingalls & Son, Waukegan, Ill.; H. A. Johnson, Monmouth, Ill.; J. C. Peers, Rockford, Ill.; M. C. Knudson, Kenosha, Wis.; L. Luchtemeyer, Blue Island, Ill.; Lundgren & Wilson, St. Charles, Ill.; E. C. Long, Shabbona, Ill.; Albert Miller, Dundee, Ill.; L. H. Miller, Streator, Ill.; C. Oesterle, Joliet, Ill. Milo Putney, Olney, Ill.; C. J. Peterson, St. Charles, Ill.; G. W. Flanders, Marcellus, Mich.; Racine Jewelry Mfg. Co., Racine, Wis.; Mr. F. G. Reamer, South Chicago, Ill.; Smyth & Lawrence, Elgin, Ill.; Julius Taussig, Hammond, Ind.; W. P. Yeoman, Washington, Ill.; Mr. Crane, Mt. Pleasant, Ia.; Mrs. John L., Davery, Elgin, Ill.; J. W. Spence, Racine Wis.; A. A. Burbank, Rochelle, Ill.; A. R. Knights, Dubuque, Ia.; J. H. Stouthamer, Milwaukee, Wis.; A. C. Le Baron, Sharon, Wis.; M. A. Lombard, Des Moines, Ia.; George Wittstein, Cedar Rapids; E. A. Dayton, Omaha, Neb.; C. A. Kiger Wichita, Kan.

Walter J. Buckley, representing the Seth Thomas Clock Co., returned Friday from Canton, O., where he superintended the



# THE OLDEST, Newsiest, Most Thorough, Most Liberal, Best Illustrated, Handsomest, PAPER.

## IT PAYS

TO KEEP IN TOUCH WITH  
TRADE AFFAIRS.

## DO SO

... BY ...

SUBSCRIBING TO

The Jewelers' Circular.



## GENEVA OPTICAL CO., CHICAGO.

CATALOGUES.

- PART 1—General Catalogue of Optical Goods.
- " 2—Microscopes and Accessories.
- " 3—Photographic Cameras, Stocks and Supplies.
- " 4—Thermometers, Barometers and Meteorological Instruments.

### PRESCRIPTION WORK

Made with Promptness  
and Accuracy.

### OCULISTS' or OPTICIANS' OUTFITS.

Trial Cases.  
Ophthalmoscopes.  
Lens Measures.

CORRESPONDENCE SOLICITED.

# ELECTRIC SIGN CLOCK.

To successfully advertise your place of business you must cater to the convenience as well as the aesthetic eye of the public.

Examine the accompanying fac-simile of our Bracket Clocks.

Did you ever see any dummy so perfectly proportioned. We make this Clock for either Bracket or Post. It measures four feet from top of ring to bottom of ornament; is 30 inches in diameter and 10 inches thick. It is water and dust proof, and the dials are protected by Glass Bezels. Power is furnished by a small Battery. The circuit is opened and closed every 30 seconds by a small contact-wheel and spring placed on your regulator, thus moving the hands ahead every half minute.

The case is made of cast iron and the mechanism is simple. This clock is no experiment but a positive success and will last you a life time.



Price, from \$40.00 up.

CORRESPONDENCE SOLICITED.

## JOLIET ELECTRIC MFG. CO., Joliet, Ill.

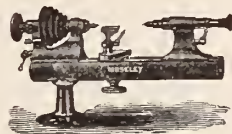

One of the best of the very best.

QUALITY IS THE STANDARD OF VALUE  
FOR WHICH WE COMPETE.

"THE MOSELEY."

"A Bread Winner" for the watchmaker. We furnish you good lathes and chucks, while the other fellow furnishes the wind.

MOSELEY & CO., Elgin, Ill.



No. 2 Moseley Wire Chuck has length, strength, accuracy.



## OPTICIANS' SCHOOL.

If you want a GOOD ROOF over your head, come to our school. We want EARNEST STUDENTS, leave the rest to us, we do not want diploma hunters.

The Chicago Ophthalmic College and Hospital,

H. M. MARTIN M. D., PRESIDENT. 607 VAN BUREN ST., CHICAGO  
Being the oldest and most favorably known College of Theoretical and Applied Ophthalmic Optics in America, having more thoroughly qualified opticians in the field than all other so-called schools combined.

## PARSONS : SCHOOL —FOR— WATCHMAKERS, PEORIA, - - - ILL

Send for Circular and Terms.

PARSONS & CO.

## G.A. WEBSTER

42 & 44 Madison St., Chicago, Ill.

Manufacturer,

AND WESTERN AGENT FOR

E. G. WEBSTER & SON, of Brooklyn, N. Y.

A. F. TOWLE & SON CO., of Greenfield, Mass

DIAMOND CUTTERS and POLISHERS looking for  
desirable and permanent positions should apply  
direct to

# FOX BROS. & CO.,

68 and 70 West 4th Street,

CINCINNATI, OHIO.

placing of one of the company's large, striking clocks with glass dials and 3,500 pound bell in the tower of the Canton Court House.

L. P. Biller, of Heintz Bros.' Chicago office went east Saturday for a ten days' visit.

A. Gluck, Dodge City, Kan., a prominent jeweler and Mayor of that city, has about recovered from a severe attack of the grip.

H. E. Vincent, representing Simpson, Hall, Miller & Co., left Saturday for Cincinnati and Louisville, and W. F. Adams the same day went to St. Louis in the house's interest.

Chas. Smith, of Smith Bros., Hastings, Minn., a well known traveler for Otto Young & Co., has retired from the road and will take it easy for a few months at his jewelry store in Hastings.

E. Rosenheim & Co., retail jewelers, 269 Dearborn St., entered two confessions of judgment in the Circuit Court a few days ago. The first one was in favor of Wm. Hunter for \$1,058, the other of Adolph Hirsch for \$1,017. Deputy Sheriff Nickerson made two levies upon the property at the above number.

The Geneva Optical Co. have entered suit in the United States Circuit Court here against F. A. Hardy & Co., for infringement of the patent rights this former company have in a lens measure. The attorneys for the plaintiffs state unqualifiedly that all lens measures proposed by others, as submitted to them, "are direct infringements upon and poor copies of the subject matter of patents already granted to and covered by letters patent of the Geneva Optical Co." The latter company sue for an injunction against F. A. Hardy & Co., restraining the manufacture of the lens measure in question.

The new position of T. R. Barnes, as manager of the Holmes & Edwards Silver Co. and the Manhattan Silver Plate Co., sits lightly on that gentlemen's shoulders. Mr. Barnes is an active, energetic worker, formerly the manager for the Manhattan Silver Plate Co. at St. Louis, with which company he has been associated several years, gradually working upward through the different grades. In the enlarged field the Chicago offers Mr. Barnes has opportunities for advancing the interests of the companies which his friends feel assured he will make the most of. Willis W. Brown, assistant manager of the companies here, has been connected with them 11 years. He is highly regarded by the two houses, and is an efficient and capable man. The interests of the house have fallen into good hands. President Thomas, of the Manhattan Silver Plate Co., and President Edwards, of the Holmes & Edwards Silver Co., were at the Chicago offices the latter part of the past week, leaving Monday for a visit to the St. Louis office before returning east.

### Los Angeles, Cal.

A. C. Abeytia has opened a jewelry store in Albuquerque, N. M.

W. T. Gillis, jeweler, Santa Monica, Cal., lost his wife a few days ago. She was 22 years old.

C. Cohn, the burglar who robbed the store of Mrs. J. Ferner, N. Main St., about two months ago, has been convicted and sentenced to the penitentiary for three years.

An ordinance adopted by the municipality of Santa Ana, Cal., imposes a license tax of \$15 per day upon all itinerant jewelry merchants who carry their stock around the streets. The ordinance was passed in the interest of the resident jewelers. It also prohibits the issuing of a license for more than 30 days to any one person.

Suit has been commenced in Los Angeles by S. Lyon, New York, against F. Marcher and wife. Mr. Lyon sold the Marchers a quantity of precious and semi-precious stones and took their notes in payment. They were, however, secured by a quantity of stock in the Kokomo Land & Water Co., of this State. The effort now is to sell this stock for whatever it will bring.

### Minneapolis and St. Paul.

C. A. Snell, optician, has opened in business at 29 4th St. South, Minneapolis.

F. O. Fiske, of Fiske & Co., Minneapolis, was married on the 8th inst. to Miss Nellie Litchfield, of this city.

Louis Gans, with H. E. Murdock, Minneapolis, was married Jan. 9, to Miss Helen K. Whittier, of this city.

Sears & Roebuck Co., Minneapolis, who have been conducting a watch business and a catalogue business, have removed to Chicago.

The H. F. Legg Jewelry Co., Minneapolis, are advertising their entire stock with store fixtures and four years' lease, or fixtures and lease without stock, for sale.

Out-of-town jewelers visiting the Twin Cities the past week were: R. H. Walker, Minto, N. Dak.; E. S. Bugbee, Tracy, Minn.; H. B. Marx, Shakopee, Minn.; Lucien Dian, Chaska, Minn.

A. E. Hall, representing the Holmes & Edwards Silver Co. and the Manhattan Silver Plate Co., with headquarters in Minneapolis, has gone to Chicago and New York on business.

H. M. Carpenter, president of the Minneapolis Jewelry Mfg. Co., was elected one of the directors of the Security Bank, of Minneapolis, at the annual meeting of the stockholders, held on the 8th inst.

L. C. Tucker, traveling salesman for the Max Meyer & Bro. Co., Omaha, Neb., is visiting his family who reside in Minneapolis. Mr. Tucker formerly represented the Reed & de Mars Jewelry Mfg. Co., Minneapolis.

John Pfister, St. Paul., who some time

ago concluded to move to California, has reconsidered the matter and will continue in business here. Mr. Pfister last week removed his place of business into new quarters at 54 E. 7th St.

Eastern jobbers and manufacturers represented in the Twin Cities the past week were: Meriden Britannia Co., by W. C. Wood; S. O. Bigney & Co., by S. O. Bigney; J. G. Cheever & Co., by J. G. Cheever; J. M. Fisher & Co., by J. M. Fisher; Foster & Bailey, by Mr. Limbach; Wm. Rogers Mfg. Co., by W. F. Adams.

### Cincinnati.

A. G. Schwab left for the east Saturday evening.

Wm. Pfeuger, of Jos. Noterman & Co., lost his mother last week. She was 83 years of age.

Frank R. Cross, formerly with the Columbus Watch Co., is now traveling for the Dueber Watch Case Mfg. Co.

Bloom & Phillips are manufacturers' agents and control eight lines in silver ware, bric-à-brac, pottery, etc. They are located at 228 W. 4th St.

Oskamp, Nolting & Co. are sole agents for the American knife sharpener, manufactured by Mossberg Wrench Co., Attleboro, Mass., and have succeeded well. The knife sharpener is indispensable when once used.

Cincinnati is to be re-numbered and the business houses are in a quandary regarding their printing and advertising. The houses will be numbered 100 to the block and Vine St. will be the dividing line instead of Main St.

The Cincinnati Wholesale Jewelers' Association held an extra session Saturday to receive the report of the committee on the circular letter to the manufacturers. The subject was fully discussed and it is the assured intention of the jobbers to protect themselves.

The Homan Silver Plate Co. were incorporated last week with a capital stock of \$500,000. Jos. T. Homan was elected president, Louis Homan, vice-president and treasurer, and Joseph Honschmeyer, secretary. The New York office is now formally open and is ready for business. The samples were shipped last week. Jos. Homan is now in New York.

Eastern travelers registered at the Gibson House last week were: C. A. Whiting, G. H. Coggsill, Charles O. Sweet, L. W. Cutler, G. W. Bunker, C. C. Darling, Chas. I. Browning, A. H. Oakley, W. C. Haskell, J. J. Sullivan, W. A. Bigelow, B. C. Crandall, Harry Osborn, J. B. Black, B. B. Brady, L. S. Hodges, F. W. Collom, C. H. Cooke, George N. Babbington, G. V. Stranberg, E. L. Mumford, J. Parker Ford, Chas. Kettlety, J. A. Jerald, Thomas F. Killany, B. A. Noble, George H. Kettlety, G. B. Angell, George A. Whiting, F. B. Kennion and W. W. Williams.

### Kansas City.

Charles Mossbacher, Wichita, Kan., was in town on personal business affairs last week.

F. G. Altman, jeweler, has rented the property at S. E. corner of 11th and Walnut Sts. for 99 years, and proposes to put up an extensive building.

The store of the Tower Jewelry Co., Coffeyville, Kan., was entirely destroyed by fire. The stock and fixtures were a total loss; covered by insurance.

Thieves entered the jewelry store of A. W. Kinney, Nevada, Mo., and secured about \$700 worth of jewelry. Entrance was effected by forcing one of the rear windows.

E. R. Stace and J. H. Tryas robbed S. A. Marshal's jewelry store at Viola, Kan., and were caught by the Wichita police. Almost all of the property stolen was recovered.

Detectives arrested in this city Ethel Roberts, alias Ethel Harrison, alias Ethel Montgomery. She is wanted in Chicago for complicity in several diamond robberies there; she is one of the most daring female thieves in the west.

Frank Crawford has been arrested at Sedalia, Mo. It was supposed he was implicated in the robbery of Ben. Levin's jewelry store in this city some weeks ago. A considerable amount of jewelry was found in his possession.

The Jaccard Watch & Jewelry Co. have just finished an elegant piece of workmanship in a Knight Templar jewel, which was presented to Past Eminent Commander E. H. Phelps, by the Fraters of Oriental Commandery, No. 35 K. T.

The Elgin Union Watch Co., with a capital stock of \$80,000, have filed articles of incorporation with the recorder of deeds in this city. The object of the company is to do a general watchmaking business. The capital stock is divided into 800 shares, and is held by the following: G. F. Benthuyesen, 648; George H. Ruddy, 75; Henry L. Strohm, 1; and Jas. T. Wilson, 1.

### San Francisco.

M. L. Levy has left for New York.

Henry Wolf has departed for the east on business.

Louis Van Vleit, formerly of the Art Jewelry Store, has accepted a position to represent Geo. Greenzweig & Co. on the road.

M. Wunsch & Co. who have been conducting a special sale are now auctioneering their goods preparatory to going out of business.

H. D. Hadenfeldt, of Rothchild & Hadenfeldt, has returned from the south. Business in general is reported to be very dull in the San Joaquin valley but the heavy rainfall has made the prospects bright for the future.

Gotthard Koehler, at one time a prominent jeweler of this city, has disappeared. He recently left his home for a walk and it is feared that he wandered down among the wharves and accidentally fell into the bay. Mr. Koehler was in his 72d year.

Rumors are current that there will be marked changes in the California Jewelry Co. commencing Feb. 1st. W. P. Morgan who has always conducted the silver department separately will go into business alone, it is said, while Mr. Marcus together with the son of Herman Levison, Louis Levison, will open a wholesale diamond house in this city.

United States Marshal Baldwin, who was appointed receiver by United States Circuit Judge McKenna of the proceeds resulting from the sale of diamonds which recently formed part of the stock of Braverman & Bostelman, as fully reported in last week's CIRCULAR, has seized \$50,000 worth of diamonds deposited in the First National Bank by Louis Braverman. The firm are very indignant and a damage suit against Max Freund & Co., the attaching creditors, is freely talked of. It is asserted that the diamonds were turned over to Louis Braverman as the firm were in debt to him in the sum of \$40,000. They further state that all their liabilities will be met in good time.

### Pacific Coast Notes.

A. P. Hall, Hanford, Cal., went out of business with the beginning of the new year.

C. T. Hastings, Santa Cruz, Cal., has sold out his business at auction and has retired.

Bert Carpenter, Placerville, Cal., while panning tailings from the deep channel at Smith's flat, found a first water diamond weighing two karats and the next day he found another gem weighing  $1\frac{3}{4}$  karats.

### Rockford.

The annual meeting of the stockholders of the Rockford Silver Plate Co., will be held Jan. 17. Three directors are to be elected.

The Rockford Watch Co. will soon begin the manufacture of a new style of watch. It is said it will be the thinnest timepiece on the market, and will be No. 16 size, open-face. It will be made only in the highest grades. Secretary Knight believed that this watch would find a ready market, and several months ago started the work of preparing the machinery. The factory opened after the holiday vacation with a large force and is running five days a week. This is better than the company have generally done after the holidays.

### Indianapolis.

J. L. Cox has opened a new store in North Salem, Ind.

C. R. Smith & Co. have opened a new store in Huntingdon, Ind.

It is reported that a new wholesale jewelry store will shortly be opened in this city.

Harry Rosebrock, Huntington, Ind., who has been located in a drug store, has moved into quarters all his own.

The partnership heretofore existing between Julius C. Walk and Carl F. Walk has been extended to Jan. 1, 1900.

Oscar Daringer started Jan. 7th for his first trip of the new year, representing Nichols, Pee & Co., in Indiana.

L. C. Phillips, Carbon, Ind.; S. J. Bradshaw, Paris, Ill.; and Geo. Swords, Fisher's Switch, Ind., were in this city buying goods last week.

Chas. W. Lauer, who for many years has represented Baldwin, Miller & Co., in Indiana, will Feb. 1st connect himself with Otto Young & Co., Chicago, to travel through Indiana and Michigan.

### Detroit.

Battle Creek jewelers last week decided to adopt standard time.

William Palmiter has purchased a stock of jewelry and will open a new store in East Jordan, Mich.

Robert Knudsen, Manistique, Mich., has moved his stock into more commodious quarters in the Gorman-Costello block.

The United States Optical Co.'s plant will be sold for the benefit of the creditors on Jan. 20. The inventory has been taken.

D. C. Rogers, Bay City, Mich., has purchased the jewelry business of John McPherson, Flushing, Mich. Mr. McPherson will move to Millington.

M. M. Dwillard, traveling salesman for the United States Optical Co., is a candidate for school inspector from the Fifth Ward. He is now secretary of the Lincoln League.

George L. Lowe, representing Kennedy & Koester, has returned from St. Ignace, Mich., where he closed out the jewelry stock of William H. LeClare on a chattel mortgage. Mr. LeClare has started a repair shop in that place.

Business with the jobbers and retailers was quiet last week. All were busy straightening out stocks and taking inventories. R. E. Brackett, Jr., Lansing, Mich., and Frank Nowan, Hadley, were the only country jewelers who were in the city.

Z. A. Crain has bought the jewelry stock of S. J. Stieglitz, Redfield, S. Dak.

Gray Bros., Port Jervis, N. Y., have leased the store, 13 Main St., and will open a jewelry establishment.

Brown Bros., jewelers, Ardmore, Ind. Terr., were recently closed by attachment. The entire stock of jewelry, furniture, fixtures, etc., passed into the hands of the attorneys of their creditors.

**Souvenirs of the Season.**

As a specimen of fine lithographing, the calendar of Parks Bros. & Rogers, makers of the American lever cuff and collar button, Providence, R. I., is highly commendable. Twelve sheets, each for a month, are attached to a large pasteboard displaying a handsome design. The reverse of the board discloses illustrations of the Kremenz "onepiece" collar button, in exact sizes, in 14 K. gold, 10 K. gold, 14 K. solid, gold tops on solid silver button, solid silver, 14 K. plated top and post with solid silver shoe, 14 K. rolled gold plate, 14 K. rolled gold plate full pearl backs, 14 K. rolled gold plate burnished in pearl backs. The process of manufacture at different stages is also illustrated. Parks Bros. & Rogers are sole agents to the jobbing trade for the Kremenz "onepiece" button.

\*

The usual neat calendar for 1895 has again been presented to the trade by Carter, Sloan & Co., 15 Maiden Lane, New York. It is similar in appearance to their attractive calendars of former years, and bears the firm's name on each sheet.

\*

As has been his graceful custom for many years, S. C. Jackson, manufacturer of jewelers' cases, trays, etc., 180 Broadway, New York, has sent his friends a neat and convenient calendar pad mounted on a red leather board with loop adapting the pad for hanging. Each leaf of the calendar contains a pertinent quotation from the poets and authors.

\*

Twelve heavy boards, each displaying the calendar for a month, attached by a silk cord, form the 1895 greeting of Emil Zothe, engraver and jeweler, 19 S. 9th St., Philadelphia, Pa. The January leaf contains a

list of the college colors, while all the other leaves contain the yearly as well as monthly calendars.

\*

A red folder with gold and black effects, containing the list of sales they made from Jan. 1st to Dec. 31, 1894, is received from H. M. Rich & Co., jewelers' auctioneers, 21 School St., Boston, Mass. The exhibit of names is a striking testimonial of the firm's ability in their line of business.

**Laneaster, Pa.**

The proceeds of the sheriff's sale of the stock and personal property of G. Howard Wertz were \$1,091.20. Nearly the entire stock was purchased by the attorney for Mrs. Wertz, the execution creditor.

C. C. Zahm has taken up the jewelry manufacturing business for many years carried on by Ernest Zahm, and will conduct it at the old stand, Zahm's Corner. J. M. Jenks, well and favorably known to the trade, will be the manager.

The manufacturing department which Ezra F. Bowman & Co. have added to their business has had surprising growth within the past year. The business is carried on distinct from the large tool and material business of the same firm and has already found a foothold in every State in the Union, a single day's mail returns coming from eleven States. The manufacturing branch is divided into the departments of engraving and die making; manufacturing of emblems and jewelry matching and repairing, stone setting, etc.; case repairing, changing and modernizing, and a watch repairing department. The firm make a point of employing only the best mechanics and their work will compare favorably with the best turned out in the large cities. Under the management

of L. C. Reissner the business has more than trebled within the past year.

**Worcester, Mass.**

A. B. F. Kinney has been elected a member of the executive committee of the Brunswick Fur Club, Barre.

A sterling silver tea service of six pieces and a large soup tureen and a ladle, manufactured by the Gorham Mfg. Co., were presented Rev. Daniel H. O'Neil, pastor of St. Peters Catholic church, Thursday night. The committee having the affair in charge went to Frank A. Knowlton's jewelry store a short time ago and outlined the plan to Frank J. Murphy, salesman, and as a result of this conference Mr. Knowlton visited the Gorham Mfg. Co., and placed the order. The silver tea service includes a coffee kettle, tea urn, hot water pot, sugar bowl, creamer and slop bowl. On the handle of the coffee kettle is the Latin inscription, in old English lettering: "Forsan et haec olim meminisse juvabit," from Virgil's *Aeneid*. On one side of the kettle is an engraving of St. Peters' church and on the opposite side, in script, is the inscription: "As a token of respect from St. Peters—84-94."

The Trenton Watch Co. had a very successful holiday trade and have been unable to keep up with the demand for their movements, although they have worked full time and their force to its fullest capacity. The company have been continually increasing their product. Their new 16-size is meeting with approbation from all who have seen it, and a large and ready sale for it during the coming year is expected. It is handsome in appearance, simple in construction and reliable in timekeeping qualities.

**BOYLE, DAVIS & GOODMAN,**

*SPECIAL AUCTIONEERS for the Legitimate Trade only.*

**63 Fifth Avenue  
NEW YORK.**

**611 Pennsylvania Ave.,  
WASHINGTON, D. C.**



S. A. BOYLE.



W. M. DAVIS.



CHAS. P. GOODMAN.

**WE PAY ALL OUR OWN EXPENSES. GUARANTEE TO MAKE YOUR SALE WITHOUT LOSS.**

SEND FOR OUR BUSINESS PAMPHLET.

CONSULT US BEFORE PLACING YOUR SALE. ADDRESS ALL CORRESPONDENCE TO OUR WASHINGTON OFFICE.

**Connecticut.**

E. F. Bennett, the New Britain jeweler, closed his auction sale Jan. 12th.

The Simpson Nickel Works, Wallingford, started up Jan. 14 on eight-hour time.

Traveling salesman George D. Munson, of Wallingford, left on an extended business trip to the far west Jan. 7th.

Jan. 14th work was resumed at the New Haven Clock Co.'s big factory. The working time will be eight hours a day.

Bridgeport's new tax list shows that the Holmes & Edwards Silver Co. pay city taxes on \$82,000, and the Aluminum Brass and Bronze Co. on \$202,600.

The Westfield Plate Co., Thompsonville, have changed their working schedule, and for the present the working hours will be from 8.30 A. M., to 6.30 P. M., six days per week.

Henry Harris, who has been nine years with Louis Herzog & Co., and Herzog, Goldsmith & Frank, New York, will shortly open a retail jewelry store and loan office at 210 Asylum St., Hartford.

The Upson Jewelry Co., Waterbury, had a remarkably successful removal sale and closed it several days earlier than at first intended. They rearranged the stock and reopened Wednesday last.

The safe in the jewelry store of Ernest Pratt, Litchfield, who suffered a \$12,000 loss by fire, as reported in last week's CIRCULAR, was opened next day after the fire, and the valuable contents found unharmed.

William J. Barber left Wallingford, Jan. 8th for Philadelphia, where he will take charge of the wholesale store of Simpson, Hall, Miller & Co. Mr. Barber will be joined in looking after the interests of the store by his brother, C. Hartwell Barber, who is now located in Boston.

David Mayer, the jeweler, who has been in business in Hartford for nearly a half a century, has decided to retire from active participation in the business he has carried on so long at 319 Main St., and a new firm will take possession about Feb. 1. A big dissolution sale is being arranged.

E. B. Whittaker, of Boston, formerly traveling salesman for Towle Mfg. Co., Newburyport, Mass., will travel for R. Wallace & Sons Mfg. Co., Wallingford, taking the route formerly covered by the late John Barton, New England States, Canada and main line of New York Central road.

Representative-elect Frederick L. Tibbals, of Milford, was presented with a

French oak buckhorn handled cane, handsomely mounted with silver and suitably engraved, at the parlors of the Milford House, Thursday night. The cane is the gift of the leading citizens of the town as a token of their appreciation of Mr. Tibbal's very able and timely work during the last election.

At the recent annual meeting of the Standard Electric Time Co., Waterbury, the office of general manager and mechanical superintendent, which for years has been held by C. D. Warner, of Ansonia, was divided and made into two distinct offices, Mr. Warner retaining that of mechanical superintendent and Leroy Upson, late of the Waterbury Watch Co., being appointed general manager. It is a change that has been suggested by Mr. Warner for some time.

Col. W. J. Leavenworth, F. A. Wallace, C. H. Tibbits and Henry Hull were on Jan. 8 elected directors of the First National Bank, Wallingford; and on the same date Samuel Dodd, Walter Hubbard, E. B. Cowles, George M. Curtis and Edward

Miller were elected directors of the Home National Bank, Meriden; C. L. Rockwell, N. L. Bradley and C. B. Rogers were elected directors of the First National Bank, Meriden, and George H. Wilcox and Charles Parker were elected directors of the Meriden National Bank; president W. J. Miller, of the Derby Silver Co., was elected a director of the Birmingham National Bank, and in Waterbury, David B. Hamilton was elected president of the Manufacturers' National Bank. The gentlemen were almost all re-elected.

**MY LADY'S HAND.**

My lady's hand is soft and white and taper—  
A hand an emperor might deign to kiss:  
But when she glides it, snake-like, o'er note paper,  
She makes of ink a trail—of words a hiss!  
Ye gods! she writes an awful, cruel letter  
(I am reading it while penning this reply).  
She stings me for a poor insolvent debtor,  
And tells me but too plainly that I lie.  
And all because her hand, so white and taper,  
Is not adorned with an engagement ring;  
The jeweler's afraid to take "my paper  
On ninety days"—the superstitious thing!  
—Louisville Truth.



**MATHEY BROS., MATHEZ & CO.**

21 & 23 MAIDEN LANE, N. Y.

BRASSUS, SWITZERLAND.

MANUFACTURERS OF  
THE SMALLEST,  
THE THINNEST,  
THE NEATEST AND  
THE BEST

**SPLITS.**

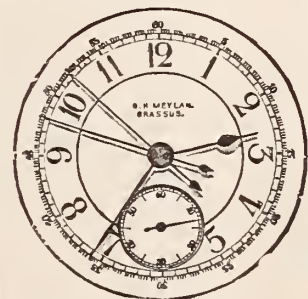

10 Size.



10 Size.

SOLE AGENTS FOR

**JAQUES • LECOULTRE • RAZORS.**

**KELLER, ETTINGER & FINK,**

SELECTION ORDERS SOLICITED.

24 JOHN STREET, NEW YORK

DEALERS IN

MOUNTERS OF

IMPORTERS OF

American Watches.

Fine Diamond Jewelry.

Diamonds.

## The History of Spectacles, Telescope, Etc.

(Concluded from p. 38, Jan. 9.)

SUPPOSING that by "instruments with long tubes" are meant the actual telescopes, those with long tubes must have been constructed long before 1618. It is deplorable that our forefathers were frequently not very precise in their mention of dates, or in their statements. It is very probable that Prince Moritz received his tube already in 1605 or 1606. Since great advantages were imagined to accrue from their use in warfare, the inventor was well rewarded and instructed to keep his invention secret. It leaked out soon afterward, however, and Borelius says that (probably in 1608) a stranger came to Middleburg, to find out the secret. But by mistake he applied not to the inventor, but to another lens grinder, by the name of Lepreg or Lipperstey, or Lippersheim, as he is indiscriminately called, who soon afterward delivered to the stranger a tube that showed objects on a magnified scale. Other writers point out Lippersheim to have been the true inventor of the telescope, without mentioning Jansen's name, or at best they state that he invented the microscope. Almost at the same time it is said Jacob Metius, in Alkmeer, constructed a telescope.

Nearly all the writings of that age concur in the statement that the telescope was invented in Holland about 1608, and probably was first constructed in Middleburg. But almost all the contemporary authors omit to mention the name of the inventor, and it will, perhaps, never be decided whether Jansen or Lippersheim was the first constructor. The simultaneous appearance of the invention, at different localities even, is not strange, because after the successful attempts had been made to combine the lenses, the invention of microscope and telescope was almost inevitable. The story that they were invented by the children of a lens grinder playing with spectacle lenses, is not improbable, although unsupported by evidence.

After the idea had become public, it was not difficult to carry it into execution, and this is the reason why so many illustrious men claim for themselves the honor of the invention. In Italy we have Francis Fontana, who claimed to have invented the telescope with two convex glasses in 1608. But since he made the claim, as late as 1646, after the instrument was in common use already, and beside this, as his assertion is unsupported by any evidence, it met with but little credence. Galileo, also, is called the inventor. But he cannot be regarded as the true one, since he acknowledged himself that the invention is of Dutch origin; he had heard that by placing several lenses together, an instrument for reviewing remote objects close by could be constructed; he had, therefore, tried to

make one himself, and been successful; and that he had soon afterward improved his first telescope essentially. In refutation of these statements, priority of claim might perhaps be accorded to J. Bapt. Porta: he says in his *magia naturalis* (1607), that it would be possible by a skilful combination of a convex and concave lens to see remote objects larger and more plainly. He adds that he succeeded with this combination in assisting the weak eyesight of his friends. The weakness was most probably short sightedness. The telescope of the Middleburg lens grinder as well as that of Galileo are still to-day called "Dutch" or "Galileo's telescopes." But Porta treats the matter in a cursory manner, and these observations did not by any means cause him to construct a special kind of instrument, so that the honor of the invention cannot be ascribed to him.

The ready reception of the instrument, altogether out of keeping with the plodding spirit of that age, was not shared in by the microscope. Although it was invented prior to the telescope, it remained almost unknown at the time when the latter was already in universal use. When the Dutch mathematician, Cornelius Drebbel, exhibited his microscope in London in 1621, he was considered to be its inventor. He was also the first to show such an instrument in Paris, in 1622. For this reason Drebbel is named by Huygens and many others as the inventor. Nor was it known in Italy until about 1624.

At present, when the microscope has become the mightiest auxiliary in the hands of the natural philosopher, it will most naturally astonish us to hear that the invention of this instrument met with so cold a reception, but in former ages there were no natural philosophers in the modern sense of the word; the philosopher's gaze was directed toward the large phenomena, but he had no inclination to investigate the smallest minutiae of nature. The revelations of the microscope simply caused astonishment; the philosopher did not know how to turn them to proper account, and considered the instrument to be one of leisure and amusement. A century afterward, even, the observations by the microscope were called "amusement for the mind and eye." Natural philosophy, however, has been developed to its present marvelous proportions only by the microscope.

When we examine the present condition of our optical instruments, we recognize joyfully the great advance made. It was indeed a laborious piece of work, a ceaseless striving after improvement and perfection of the optical and mechanical parts, but a satisfactory success is the results of our troubles. We may declare proudly that the greatest advances were made since the beginning of this century, and, indeed, most of them in the time of persons still living. Should arrangements be matured for celebrating the events, the scientists and intelligent people may be satisfied with the results obtained.

## Workshop Notes.

**Care of Screws.**—The repairer, in his every-day work, will often come across screws that are deserving of the name, others that are an indifferent set, and others that are called screws simply by courtesy. But let him remember never to allow a screw that does not draw to pass by him; he should always replace it with one properly fitting.

**Inserting a New Pivot.**—In inserting a new pivot, measurements must, of course, be taken for length, and the first thing to be done after the insertion of the plug is to stone it off to proper length, and then turn it true and finish. Never attempt to cut the end of the staff to conform to the pivot which you are turning; but when you start to turn, begin just where the staff leaves off and the plug begins, and make the pivot conform to the staff.

**Making Drills.**—Make your own drills out of sewing needles as follows: Draw the temper thoroughly by holding the needle in the flame of a lamp until nearly red hot; then allow it to cool slowly; file it down considerably smaller than the size of the hole you wish to drill, and file the end flat; then spread the end by tapping with a hammer, using a stake or punch block with the edge rounded off to lay the end of the needle against; when the end is spread sufficiently so that the drill will not join in the hole, harden it by heating it in the flame of a tallow candle (the strength of this flame being less than alcohol, and therefore less liable to burn the steel by overheating) and cool by shaking it backward and forward rapidly in the air, if a small drill; if of a larger size, by plunging it several times into a piece of beeswax; sharpen by rubbing it on an oilstone slip on two sides only, leaving a small knife edge as the center instead of a point.

**Shape of the Jewel Hole.**—What shape is to be given to the jewel hole when the ends of the pivots turn against cap jewels, is an interesting question, and has been treated frequently in THE CIRCULAR, and will be, perhaps, as long as the latter will exist, to be treated again by some successor. The course usually pursued is to make them concave inside and convex outside. The concave brings the parts into closer connection and makes the oil appear better. The convex, on the other hand, derives some advantage from the position of the flat counter pivot over it. What shall be the distance between the cap jewel and the convex part, is another disputed question. When they are placed just above, the ends of the pivots turn in the hole and the oil is more likely to spread, and if the cap jewel is too far away, the oil may run off altogether. The distance should be such that the end of the pivot should be outside of the hole when the arbor is working in the hole jewel only. The rule followed in the depth of the hole is usually to make it as deep as it is wide; deeper holes would only increase the effect of the oil.



# L. STRAUS & SONS,



IMPORTERS AND MANUFACTURERS.

China, Pottery and Glassware, 42, 44, 46 & 48 Warren St. and 116 Chambers St., N. Y.  
PARIS, CARLSBAD, RUDOLSTADT, LIMOGES, STEINBOHONAU.



## THE LATEST NOVELTY IN BIBLE BOOK-MARKS.

MOUNTED WITH  
Sterling Silver or Gold Ornaments,

ON ALL SILK RIBBONS, 8 1-2 INCHES LONG  
WITH APPROPRIATE QUOTATIONS

**WOVEN IN THE SILK.**

Nine different quotations. Ribbons in the following colors: Purple, black, white and lilac. Can be sold profitably at a popular price. Made only by

**STONE BROTHERS,**  
535 Broadway, NEW YORK.

When you buy

Cut Glass

You want the best!

That which bears our  
Trade Mark

Has no superior

And will prove profitable and satisfactory.



**T. B. CLARK & CO., Inc.,**  
860 Broadway, N. Y.,

Factories, HONESDALE, PA.

N. E. Cor. 17th St. & Broadway.

### Philadelphia College of Horology

Is not the largest but is the finest school in the country. A practical school to learn watch-making, engraving, and jewelry repairing. One tuition pays for all branches. Send for prospectus.

**F. W. SCHULER, PRINCIPAL.**  
1213 Filbert St., Philadelphia, Pa.  
Write for particulars of our corresponding course.

JACOT & SON  
IMPORTERS AND  
MANUFACTURERS  
OF  
**MUSICAL BOXES** 39  
Union Sq.  
New York.

### SAFES FOR JEWELERS.

**MOSLER, BAHMANN & CO.,** 518 BROADWAY  
NEW YORK.  
Patent Fire and Burglar Proof Safes.

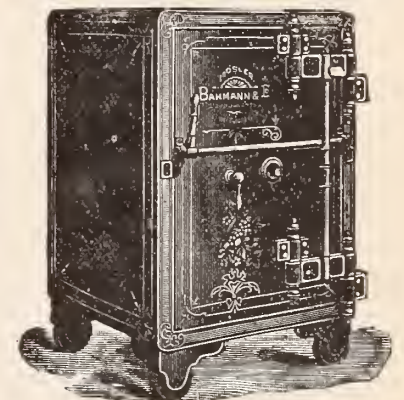

Large Assortment Always on Hand.  
Send for our Representative.  
Special Safes to Order.  
Jewelers' Safes a Specialty.

## AMERICAN WATCH TOOL CO.

ESTABLISHED 1872.  
INCORPORATED 1894.



THE  
**Webster-Whitcomb**

1-4 Size

GROWS IN POPULARITY.

PRICES AS LOW AS CONSISTENT WITH QUALITY.

Ask your Jobber for Price List of 1895, or write to us at

Stoney-Batter Works, Chymistry Dist., Waltham, Mass.

IMPORTERS OF  
**DIA MONDS,**  
WATCHES, JEWELRY, CHAINS,  
NOVELTIES, ETC.  
Latest Designs. Lowest Prices.

JOBBER IN

**AIKIN-LAMBERT  
JEWELRY CO.,**  
19 Maiden Lane, New York.  
CHICAGO BRANCH '03 STATE ST.

# FERDINAND BING & Co.,

106 GRAND ST., N. Y.

NEW DESIGNS IN \_\_\_\_\_

China Clocks and Gilt Bronze Sets, Fine Painted

Dresden Goods in Vases, Cups and Saucers, and Plates;

Cararra Marble Statuary, French Cabinets and other

Fancy Furniture.



## TOWLE MFG. Co.,

Silversmiths.



OLD ENGLISH BUTTER SPREADER

FACTORIES:

NEWBURYPORT,

MASS.

CHICAGO OFFICE, 149-151 STATE ST.

## FLAT WARE AND HOLLOW WARE

STAMPED



IS THE GENUINE.

Manufactured by

WM. ROGERS M'F'G CO.,  
HARTFORD CONN.

## Jules Jürgensen

OF COPENHAGEN.

The reputation these watches have maintained for fifty Years has never been equalled, being made on strictly scientific principles and no expense spared to give the Best results in mechanism and timekeeping qualities.

SOLE AGENTS.

John C. Hyde's Sons,  
NO 22 MAIDEN LANE.

## For BADGES and MEDALS,

Flag Pins, Class Pins, Class Rings  
and Special Work of all Descriptions,

SEND TO E. R. STOCKWELL, MANUF'R,  
19 John Street, New York.

DON'T FORGET THE JEWELERS' CIRCULAR PUBLISHING CO.'S BOOK LIST when in want of any technical book in the Jewelry or Kindred Trades.



J. B. & M. KNOWLES & CO.

MAKERS OF

STERLING SILVER WARE

FACTORY:  
PROVIDENCE R.I.

SALESROOM:  
260 BROADWAY N.Y.

## AIKIN, LAMBERT & CO.,

CHICAGO BRANCH: 103 State Street.

No. 19 MAIDEN LANE, NEW YORK.

Manufacturers and Exporters  
Gold Pens, Holders, Pencils,



Toothpicks and Novelties

MERCANTILE

FOUNTAIN PEN.





## THE TRADE MARKS ON PORCELAIN AND POTTERY.

PART II.—MARKS ON ENGLISH WARES.—MARKS ON FRENCH PORCELAIN.

CONCLUDING with the few marks below, the exposition commenced last week of the marks stamped on the fine English pottery wares that are sold by jewelers, we will take up in this instalment also the stamps on French porcelain, treating the subject exhaustively.



GEO. JONES CRESCENT CHINA.

The trademark of Geo. Jones & Sons' Crescent ware has as its salient feature the monogram "G. J." and underneath a crescent with the words "& Sons."



CAULDON.

The trademark of the Caudon ware of Brown, Westhead, Moore & Co., is shown above. There is another mark, seen on small pieces as cups, which consists simply of a crown with the words "Caudon Ware, English."



OLD HALL.

The Old Hall trademark is distinctive consisting of a three turreted castle with the name, Old Hall, and underneath, the date, 1790, in an open knot of cord.



COPELAND.

The above is the mark on Copeland ware, containing the word Spode above, and the word Copeland below.



WEDGWOOD

WEDGWOOD.

The Wedgwood trademark on china is easily recognized being an illustration of the celebrated Portland vase above the name, Wedgwood. This trademark does not appear on the Jasper ware in which facsimiles of this vase are now made.

### Marks on French China.

The Ch. Field Haviland china manufactured by E. Gérard, Dufraissex & Co., Limoges, France, will be recognized by the



HAVILAND & ABBOT, LIMOGES CHINA.



two marks above. The former appears only on their white ware, while both marks are stamped on the decorated pieces. The American agents for this ware are Haviland & Abbot, 29 Barclay St., New York.

The following stamp will be found on the Limoges china and novelties of Chas. Ahrenfeldt & Son, 50 and 54 Murray St., New York. The two small stamps will be used upon



LIMOGES—C. AHRENFELDT & SON.

the product of the firm's new factory at Limoges, France.



DELINIERES & CO.

The china and novelties of R. Delimieres & Cie, Limoges, on which the above trademarks appear, may be had from their New York agents, H. Endemann & Co., 58 Murray St.



POUYAT WARE.

The decorated porcelain of La Société La Céramique, J. Pouyat, Limoges, France, bears the two marks reproduced above. The sole agent for this ware in the United States is Alfred Lindsay, 56 Murray St.



P. H. LEONARD'S LIMOGES.

This stamp identifies P. H. Leonard's French china table specialties for the jewelry trade. Mr. Leonard's warerooms are at 78 Reade St., New York.



HINRICHS & CO.'S LIMOGES.

These trademarks are borne by the French china novelties of Hinrichs & Co., 31 Park Place, New York.

The Connoisseur.

(Continued from page 41).



BAWO & DOTTER'S ELITE.

The mark of the Elite china is borne on an extensive line of white and decorated table ware, novelties and specialties handled by jewelers. The ware is sold only by Bawo & Dotter, 26 to 32 Barclay St., New York.

Theo Haviland  
Limoges  
FRANCE

THEO. HAVILAND'S LIMOGES.

Theo. Haviland, Limoges, France, on whose china the above stamp appears, is represented in the United States by W. L. Briggs, 25 Murray St., New York.



LEVY, DREYFUS & CO.'S LIMOGES.

This mark will be found on the Limoges novelties of Levy, Dreyfus & Co., 11 Maiden Lane, New York.



On White China.



On Decorated China.

HAVILAND & CO.'S LIMOGES.

When decorated china bears both of the above marks it is the product of Haviland & Co., Limoges, France, whose New York branch is at 45 Barclay St.



Wm. GUERIN & Co.  
Limoges  
FRANCE.

GUERIN'S LIMOGES.

Guerin china, which bears one or both of these trademarks is manufactured by Wm. Guerin & Co., Limoges. The New York agent for this ware is Chas. Streiff, 31 Barclay St.



WHITE DECORATED

LANTERNIER LIMOGES,  
GEO. BORGFELDT & CO.

The product of A. Lanternier & Co., Limoges, France, whose china bears these marks, is controlled in this country by Geo.

Borgfeldt & Co., importers, 18, 20 and 22 Washington Place, New York.



THE A. K. LIMOGES.

The A. K. china on which this mark is stamped was formerly that of A. Klingenberg, but is now controlled here by his successor, C. L. Dwenger, 35 Park Place, New York.



CROWN PAIRPOINT WARE.

This mark only appears on French china, which has been imported in blank, and decorated in this country in American styles by native artists, at the factory of the Pairpoint Mfg Co., New Bedford, Mass. Pieces of this description are known as Crown Pairpoint ware. The New York branch of the Pairpoint Mfg. Co. is at 46 Murray St.

A H & Co  
V

A. Hache & Co.,  
Vierzon.

FRANCE

HACHÉ & CO.'S PORCELAIN.

Both of these stamps will be found on the decorated china manufactured by Alfred Haché & Co., Vierzon, France. The American agents for this ware are the Craighead Mfg. Co., 38 Park Place, New York.

CODDING BROS. & HEILBORN,

North Attleboro, Mass.

Makers  
OF

QUICK SELLING NOVELTIES

In Sterling Silver.

NEW YORK OFFICE—C. A. Vanderbilt, 178 Broadway.

CHICAGO OFFICE—F. A. Buck, 103 State Street.

\$3.00

FORMERLY

\$6.00

Ivory and  
Enamel  
Miniatures

Best  
Workmanship.



Original  
Inventor and  
Patentee of

Miniatures

—ON—

Gold and  
Silver.

PATENTED  
November 12, 1889

LEON FAVRE,

107 EAST 26TH STREET,  
NEW YORK.



L. STRAUS & SONS' LIMOGES.

L. Straus & Sons, 42-48 Warren St., New York, distinguish their many lines of Limoges china by the mark illustrated above.



LIMOGES OF LAZARUS, ROSENFELD & LEHMANN.

When French china bears the above mark, it comes from warerooms of Lazarus, Rosenfeld & Lehmann, 60 Murray St., New York.



RÉDON LIMOGES.



The above marks will be recognized as distinguishing the china of M. Rédon, Limoges, France. The American branch was recently opened at 43 Murray St., New York.

FERD. FUCHS & BROS.

SILVERSMITHS,

MAKERS OF STERLING SILVERWARE,

808-810 Greenwich St., New York.

No jeweler or watch repairer should be without a copy of "WORKSHOP NOTES," a new and very useful book for the workshop. Send for circular containing a complete index of the book, and judge of its merits for yourself.

# HINRICHS & CO., 29 and 31 Park Place, NEW YORK.

IMPORT AND STOCK SAMPLES FOR SEASON OF 1895 READY.

## THE BOWDEN SEAMLESS RING

IS MADE ONLY BY

### J. B. BOWDEN & Co.,

Makers of Finger Rings of every Description.

REMOVED FROM BROADWAY AND JOHN STREET,  
 TO 3 MAIDEN LANE,  
 NEW YORK.

## HAGAN, WHITE & CO.,

MANUFACTURERS OF

### GOLD AND SILVER MOUNTED CANES, UMBRELLAS & NOVELTIES.

RICH AMERICAN CUT GLASS, SILVER MOUNTED.  
 248 WEST 23D STREET, NEW YORK.

**A Complete Establishment**  
 MEANS  
**PERFECT WORK**  
 In every detail of  
**ASSAYING,**  
**REFINING**  
 AND  
**SMELTING.**

The proof that mine is such lies in the prompt and satisfactory returns invariably given all my customers. ARE YOU ONE?

HIGHEST MARKET RATES FOR OLD GOLD AND SILVER.

**J. RATHBONE,**  
 Nos. 1 to 9 Matthewson St., cor. Cove, Providence, R. I.

**A. J. COMRIE,**  
 AUCTIONEER,  
 22 John St., N. Y.

SPECIAL SALESMAN OF WATCHES, DIAMONDS, BRIC-A-BRAC, FOR ESTABLISHED JEWELERS.  
 WRITE FOR PARTICULARS.

<p><i>Wilkes-Barre, Pa.,        Oct. 27th, 1894.</i></p> <p><i>I consider myself benefited over \$2,000.00 by engaging the Col. and can recommend him in confidence to all as he will make money for anyone.—Yours resp'y,        W. O. Blase.</i></p>	<p>My references are all dated, not from interested wholesalers, but from parties for whom I have sold.</p>	<p><i>Plymouth, Pa.,        Nov. 19th, 1894.</i></p> <p><i>The auction sale made by Col. Fechner in the hardest times this town has ever seen has averaged over 47 per cent. profit on all goods sold by him.—        John P. Harris, Jeweler.</i></p>	
<p><b>No Stock too Fine or Expensive for me to Sell.</b></p> <p>Cater for and get the Largest Lady Attendance of any Auctioneer known.  <b>STRICTLY SOBER, TRUTHFUL AND HONORABLE.</b>        A few open dates for the first that need my services.</p>			
<p>I belong to no syndicate or company, furnish no fakers as salesmen. I have one or two capable assistants with me.</p>	<h2>ST. CLAIR FECHNER,</h2> <p>* The Jewelers' Auctioneer. *</p> <p>Residence and Address—612 PENNSYLVANIA AVENUE, N.W., WASHINGTON, D. C.</p> <p>If you are in financial straits, if you wish to raise money, if you are overstocked, if you wish to increase custom, if you wish to avoid bankruptcy, write to me, and I will be frank, open and candid, and tell you what can be done, and I will do all I agree. I never disappoint or mislead anyone.</p> <p>Every Jeweler should have an Auction at least once in five years.        I have positively made <b>NO FAILURE IN TWO YEARS.</b>        Write for my Book, References, Terms, etc. No person will see your letters.</p> <p>When I am through with my business, if you continue, you will have from 25 to 100 per cent. of new customers.</p>		<p>I am an expert and fully conversant with the values of all kinds of Diamonds, Watches, Jewelry and Bric-a-Brac.</p>
<p>Place the management of the sale in my hands, you handle all the money. Settle with me when all is done. If I have not made money for you, I will pay you \$1,000.00 in cash.</p>	<p>I have new and original ways of drawing large lady audiences. They draw the gentlemen buyers that make my sales a success where many so called auctioneers fail.</p>		

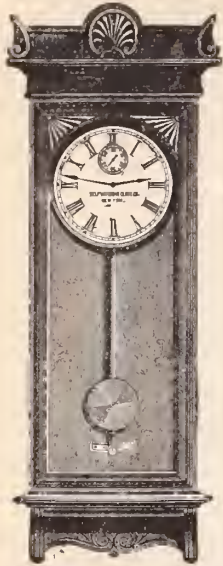

**SELF WINDING CLOCK CO.**

NEW YORK-CHICAGO.

**HALL CLOCKS,  
OFFICE CLOCKS,  
Synchronized Time Plants.**

No Winding. Corrected Hourly

BY TELEGRAPH SIGNALS OVER WESTERN UNION TEL. CO.

Wires from U. S. Naval Observatory, Washington, D. C.

General Office:  
26 BROADWAY, N. Y.

Branch Office:  
Columbus Memorial Bldg, Chicago.

Sold by all whole-  
sale dealers at manu-  
facturer's price.

**A. N. CLARK & SON**  
PLAINVILLE  
CONN.

Manufacturer of the Celebrated  
**LOOP WATCH KEY.**

The Best for the Price in the World.  
CROSBY'S JEWELING TOOLS IMPROVED.

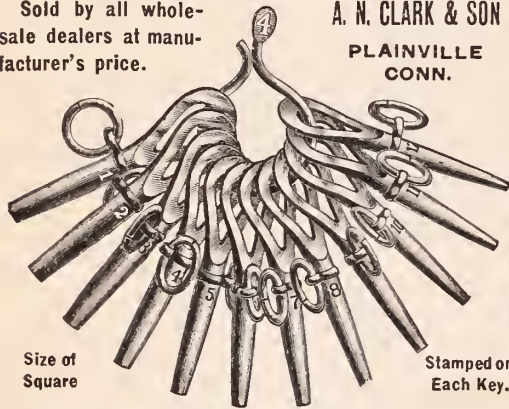

Size of  
Square

Stamped on  
Each Key.



Will quote royalty or price for the manufacturing of articles of real worth.

**DIAMONDS.**

**C. COTTIER & SON,** IMPORTERS OF  
14 MAIDEN LANE, NEW YORK. PRECIOUS STONES,  
C. A. RICHARDS, Agt. 151 Weybosset St., Prov., R. I.

**FANCY GEMS.**

**PRESCRIPTION WORK.**  
**QUEEN & CO.,**  
1010 Chestnut Street, PHILADELPHIA.  
SEND FOR PRICE-LIST AND ORDER FORMS.

SEND FOR PRICE-LISTS

**JEWELERS' MACHINERY**  
W.W. OLIVER BUFFALO, N.Y.

DRAG BENCHES ETC.

**U. S. SMELTING & REFINING WORKS.**

Sweep Smelting and Assaying, Platinum in Plate and Wire. Chemically Pure Copper. Ore and Bullion Assays a specialty.

Highest prices paid for old gold and silver. Sole manufacturers of Phoenix Flux and Eureka Alloy.

**M. WOLLSTEIN.** - 25 John St., New York.

**Diamond Polishing Machines.**

We build these machines complete with latest improvements also polishing wheels, tongs, dous, weights, shafting, belting, ventilating fans, gear-cutting, die blanks, etc.. We do general repair work on jeweler's machinery.

**THE ARTHUR CO.,**

General Machine Works,  
86 JOHN STREET, NEW YORK.

**WOOD & HUGHES,**  
STERLING SILVERWARE MANUFACTURERS

New York Agents for the Derby Silver Co  
**FINE QUADRUPLE PLATED WARE,**  
No. 16 JOHN STREET, NEW YORK.  
206 Kearney St., San Francisco, Cal.  
HASKELL & MUEGGE, Agents.

**B. & W. B. SMITH,**  
220 W. 29th St., New York.

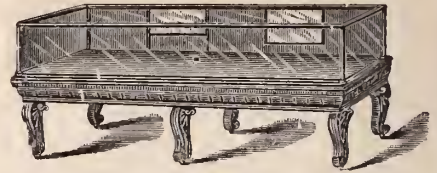

Improved Dust-Tight Counter Cases,  
Perpendicular Sliding Doors.

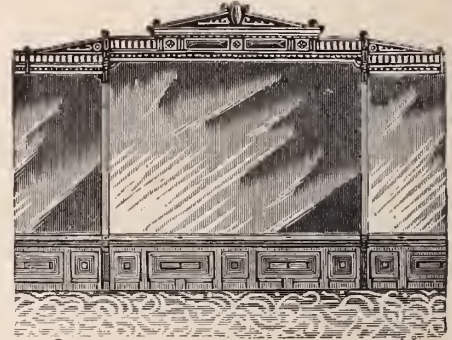

Improved Dust-Tight Wall Cases.  
Furnished with Improved Shelving and arranged for Electric Lighting.

.. OUR ..  
**SPECIALTY**  
The Largest Stock of  
**CHIMING**  
AND  
**STRIKING**  
**HALL CLOCKS**  
ever shown.

**Chas. Jacques**  
CLOCK CO.,  
22 Cortlandt Street,  
NEW YORK.

**S. F. MYERS & CO.,**  
Manufacturing and  
WHOLESALE JEWELERS,  
1895 Issue, No. 39.

**OUR ROYAL CATALOGUE**

Illustrates all that is new, unique  
and desirable in  
everything that pertains to jewelry.  
600 pages, size of this publication.  
Free to dealers.

**SEVEN DOUBLE FLOORS.**  
**TWENTY-TWO DEPARTMENTS.**

Myers Buildings, 48-50 Maiden Lane, New York.  
33-35 Liberty St., New York.

**IT PAYS** TO KEEP IN TOUCH WITH TRADE AFFAIRS. For 4c. a Week will do it. **Subscribe.**

**DIAMONDS** and Cutters. **L. & M. KAHN & Co.,** 172 Broadway, Cor. Maiden Lane, N. Y. **DIAMONDS**

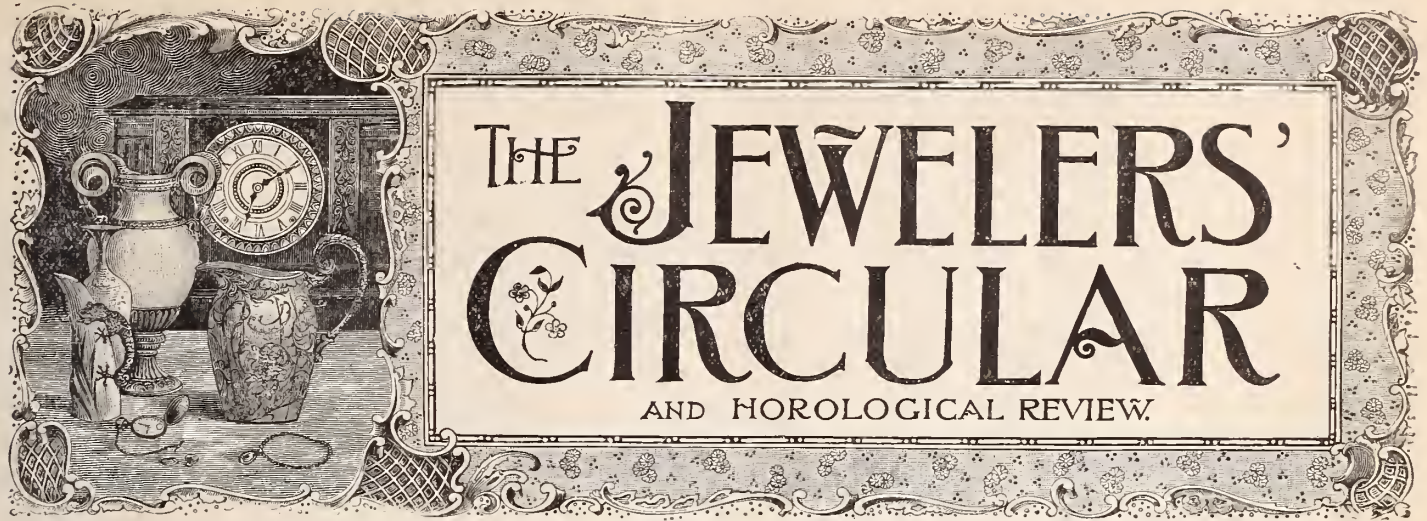

Copyright by THE JEWELERS' CIRCULAR PUB. CO.

189 Broadway, New York.

Entered at the Post Office in N. Y. as second-class matter.

VOL. XXIX.

NEW YORK, WEDNESDAY, JAN. 23, 1895.

No. 26.

RETROSPECTIVE GLIMPSSES OF THE ANTWERP EXPOSITION.

PART II.

IN the French section the jewelry department included 54 exhibits, some of which were very interesting, although several of the best Parisian jewelers were missing. In Boucheron's glass cases were especially noticed: a necklace formed of two corn ears consisting of tiny pearls and brilliants, the corn ears dropping in front and being held at the back with a rippling diamond ribbon; also a diadem showing diamond reeds with a dragon fly resting on one of them; besides several sprigs of flowers in *joaillerie*, such as corn-poppies, fuchsias, convulvi, etc., brooches formed of elegant diamond *motifs* with rubies, emeralds, sapphires, and topazes tastfully introduced here and there. Among artistic metal works the writer remarked a watch in chased steel with gold inlayings. This watch is adorned on the front and back of the case with figures full of life in relief on a ground of conventional foliage, these figures representing the 12 hours. An infant is seated on the pendant of the watch.

Lefebvre *fils aîné* had a varied display in which were several silver plaques reproducing religious scenes in repoussé, a Renaissance jardiniere of perfect workmanship, some bracelets in massive gold finely chased by Brateau, portrait frames, hand mirrors, clasps in worked gold, and also a

collection of Louis XVI. studs elegantly adorned with brilliants of fine quality.

Félix Desprès clearly showed what an inventive jeweler he is. Let us mention his bracelet in supple network surmounted with a sapphire having rays of diamonds shooting all round it; this star being removed becomes a brooch; a diadem formed of a ribbon bordered with rubies and brilliants and tied into a loose knot of a pretty and natural effect; another diadem being a succession of diamond fleur-de-lis of well graduated sizes; a necklace formed of wolf's teeth consisting of diamonds and pearls; another in a striking Arabian style; a very light necklace showing lotus flowers; a corsage *traine* called *reine des bois* (queen of the woods), being a diamond branch of sweet briar.

A remarkable diamond necklace consisting of floral *motifs* in pierced work; larger diamonds, with a platina setting being fashioned in the shape of a nail, are applied on it at regular intervals; while well faceted stones hang from pendants.

Louis Ancoc had in his display many artistic bracelets, brooches, and other small articles in gold finely chased in the Louis XVI. and Renaissance styles; also a beautiful miniature portrait of Empress Catherine II. of Russia in a handsome gold frame of a Byzantine style richly adorned with gems in *cabochon*.



LOUIS XVI TOILET TABLE IN SILVER AND GOLD INLAYINGS—CHRISTOFLE & CO.

# DEITSCH BROTHERS,

MANUFACTURERS OF...



Leather Goods,

Tortoise Shell Goods,

Ebony Goods,

Sterling Silver Novelties,

7 EAST 17TH STREET,

NEAR UNION SQUARE,

NEW YORK.

## HAGAN, WHITE & CO.,

MANUFACTURERS OF

GOLD AND SILVER MOUNTED CANES, UMBRELLAS & NOVELTIES.

RICH AMERICAN CUT GLASS, SILVER MOUNTED.

248 WEST 23D STREET.

NEW YORK.

For BADGES and MEDALS,

Flag Pins, Class Pins, Class Rings and Special Work of all Descriptions,

SEND TO E. R. STOCKWELL, MANUF'R, 19 John Street, New York.

## "MOTHER GOOSE" STICK PINS.

PATENTED NOVEMBER 6 AND DECEMBER 4, 1894.



Bo Peep.



Old Mother Goose.



The Frog that would a wooing Go.



Tom the Piper.



Hey diddle diddle, The cat and the fiddle.



Hot Cross Buns, one a penny two a penny.



Little Jack Horner.



Humpy Dumpty.



There was an old woman tossed up in a basket.



Correct in style. Bound to sell.

The best selling line of Stick Pins to date.

Elegant in finish. Prices Right.



ENAMELED SHIELDS.

The Latest out. Engraved Silver and Roman finish. Be sure and see them.

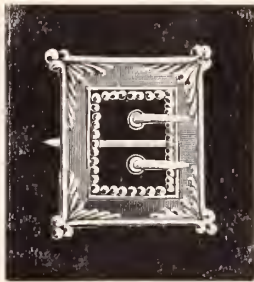

The Newest Fad.

Elegantly Engraved and Enameled.



Beautiful Designs.

Prices that defy Competition.



Finished in Silver and Roman.

Put up in our best style.



SHEPHERD'S CROOKS.

New Designs. Engraved Silver and Roman finish. Be sure and see them.

### CZARINA BUCKLE COLLARETTES

### CZARINA BUCKLE STICK PINS.

The Latest Novelty.

Don't Fail to see them.

GEO. F. GREENE & CO., Manufacturing Jewelers, 111 and 113 Point Street, PROVIDENCE, R. I.

## AIKIN, LAMBERT & CO.,

CHICAGO BRANCH: 103 State Street.

No. 19 MAIDEN LANE, NEW YORK.

Manufacturers and Exporters Gold Pens, Holders, Pencils,



Toothpicks and Novelties

# MERCANTILE

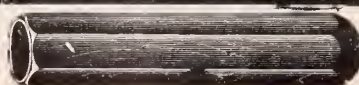

# FOUNTAIN PEN.



# FOSTER & BAILEY,



100 RICHMOND ST., PROVIDENCE, R. I.

## Manufacturing Jewelers and Silversmiths.

925/1000.

### HEADQUARTERS FOR MANICURE GOODS.



Garters

Link Buttons

Scissors

Neck Chains

Bag Tags

Glove Buttoners

Hat Marks

Chain Mountings

Pen Wipers

Shirt Waist Sets

Emery Balls

Crosses, Earrings

Match Boxes

Solid Gold Locket

Coat Hangers

Locket and Charms

Pocket Knives

Silver Belt Buckles

Pocket Combs

"Mount Hope" Buttons

Paper Cutters

Bracelets and Padlocks

Seals, Button Hooks

Pins and Neck Buckles

And Silver Novelties

Rolled Plate Watch Chains

Without End, all Sterling.

$\frac{1}{10}$  Gold Vest and Dickens Chain.

And also those

**HANDY SETS FOR TOILET IN LEATHER ROLLS.**

In the display of the talented enamelist Auguste Jean, was noticed a jewel casket in chased silver showing on its five faces, including the lid, scenes in enamel painting

bonbon box adorned with a fine miniature portrait circled with pearls, etc.

Christofle & Co.'s display in the silver and silver plated lines was very important, including besides many patterns in dinner services, coffee and tea sets, candelabra, etc., several statuettes in silver, and in ivory made by the best French sculptors of the day. I must particularly mention the Louis XVI. toilet set of a most artistic rendering. The engraving on the front page reproduces the toilet table, which was designed by Reiber, who also made the engraving. The two figures leaning against the columns of the candelabra, which hold the looking glass, were modeled by Gumery. The artist, Carrier-Beleuze modeled the figures of the graceful little cupids; the ornaments were made by Chéret. One of the figures standing by the looking glass is an allegory of art, leading to coquetry; she wears a pearl necklace and looks at herself complacently in a hand mirror. The other figure, with her abundant flowing hair, personifies nature. The caryatides which support the toilet table have on their heads a pretty basket of flowers, which gives a graceful appearance to the corners of the table. All the figures are of silver, and the ornaments, trophies and flowers so delicately chased, are in vari-colored gold. The table is in Mosaic work consisting of Persian lapis and Mont Blanc jasper, with silver and gold inlayings.

The jewelry department, in the German section, included 41 exhibitors, the Pforzheim exhibit alone comprising 29 firms. On the occasion of the World's Columbian Exposition, THE CIRCULAR described at full length the exhibits of the Pforzheim manufacturers. Although several houses which were represented at Chicago, abstained from exhibiting at Antwerp, being replaced there by other firms whose articles had not been sent to the American exposition, yet the *genre* exhibited in both places was the same. German manufacturers are above all practical; they make those patterns only which, being comparatively cheap and sufficiently elegant for current lines, are bound to sell on a large scale. The articles are made almost entirely by machine work, and the production is enormous. The sale must be very extensive in order to allow these manufacturers a profit. Wages are, on the average, very low in Germany, and the division of labor is so great as not to require on the part of artisans, a general and varied experience in jewelry work. Yet industrial schools are well attended; apprentices of both sexes obtain a practical teaching, and numerous artisans, anxious to become more and more proficient in their art, follow regularly the evening schools.

Among German exhibitors at Antwerp, Louis Fiessler & Co.'s display, showing all known chain patterns in the current lines—*colonne* chains, cable work, successions of balls alternating with links, besides pretty patterns in dull or polished gold, adorned

with gems; also pendants in enameled gold, with addition of precious stones, was important.

The few exhibitors in the silver lines



A GOOD SPECIMEN OF GERMAN ART WORK.

illustrating the five senses, a tiny clock five centimeters high, in chased silver, decorated with enamel in the style of Leonard Limosin; an olive shaped scent bottle in Sèvres blue enameled gold, *genre capiton* incrustated with diamonds; a chased gold



WATCH OF CHASED STEEL, WITH GOLD INLAYINGS.

showed curious imitations of ancient German styles. The silver cup here illustrated is a remarkable specimen of German art work. The outlines are at once bold and graceful. The halleberdier standing on the cover is in a natural attitude. The



A FRENCH JEWEL AT THE EXPOSITION.

heads in full relief coming out of the four bull's eyes, greatly add to the artistic effect of the ensemble, and all the details, in various reliefs, are beautifully chased.

FRANCK. .

(To be continued.)



*Pairpoint*

# MANUFACTURING COMPANY.

## Gold and Silver Plate



No. 3749. MATCH HOLDER.

WE ARE MAKERS OF THE  
LARGEST AND LOWEST PRICED

.....LINE OF.....

“Crown Pairpoint” China

Rich Cut Glass,

Fine Decorated Art Goods,

.....TO BE FOUND IN THIS COUNTRY.



No. 4908. SMOKING SET.

“WHEN IN DOUBT”

--- BUY ---

✻ PAIRPOINT GOODS.

Factories, New Bedford, Mass.

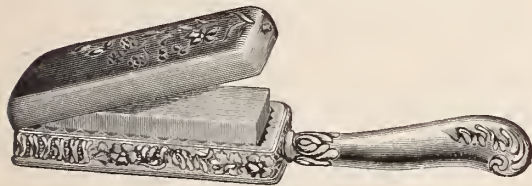

No. 2832. KNIFE SHARPENER.

### HOLIDAY NOVELTIES

..... OF EVERY DESCRIPTION.

**FREE**

OUR LATEST

SILVERWARE CATALOGUE No. 10, or  
CUT GLASS CATALOGUE No. 11

Will be mailed you upon receipt of address.



SALESROOMS :

NEW YORK, 46 Murray Street.

CHICAGO, 224 Wabash Avenue.

SAN FRANCISCO, 220 Sutter Street.

MONTREAL, P. Q., Temple Building.

We sell to the legitimate Jewelry and Stationery trade only.



NEW YORK

CITY, U.S.A.

## CHOICE PAPERS

MAKERS OF

# FINE STATIONERY

For Correspondence, Wedding and Business Use, handsomely boxed, specially suited to the Jewelry Trade.

18 MURRAY STREET, NEW YORK.

## FLAT WARE AND HOLLOW WARE

STAMPED



IS THE GENUINE.

Manufactured by

WM. ROGERS M'F'G CO.,  
HARTFORD CONN.

H. M. RICH & CO.,  
Jewelry · Auctioneers,  
21 School Street.  
BOSTON, MASS.

## CROUCH & FITZGERALD.

Jewelry Trunks and Cases,  
161

Broadway,  
Bet. Cortlandt and  
Liberty Sts.,  
688 B'way,  
701 6th Ave.,

NEW YORK

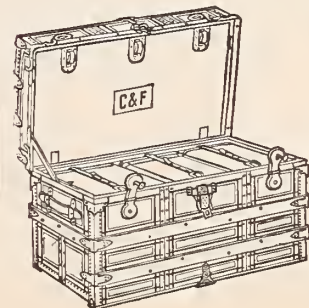

# R. WALLACE & SONS MFG. CO.

## SILVERSMITHS,

WALLINGFORD, - - - - - CONN.



No. 20. FLASK.

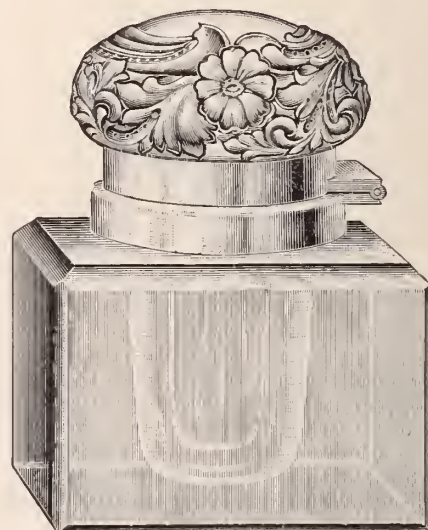

No. 53. INK BOTTLE.  
CHASED TOP.

Trade Mark.

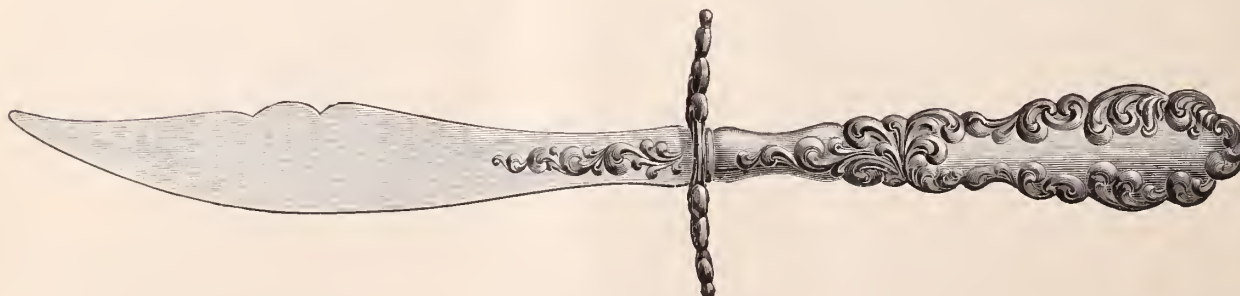

No. 39. PAPER CUTTER.

NEW YORK  
226 FIFTH AVENUE.

SAN FRANCISCO  
120 SUTTER STREET.

CHICAGO  
86 WABASH AVENUE.

# BUSINESS IN 1894, AND PROSPECTS FOR 1895.

INTERVIEWS BY THE JEWELERS' CIRCULAR'S CORRESPONDENTS WITH PROMINENT DEALERS THROUGHOUT THE COUNTRY.

*Continued from page 10, Jan. 16, 1895.*

## Pittsburgh Dealers Generally Pleased With Trade Conditions.

PITTSBURGH, Pa., Jan. 5.

The existing trade situation is a noticeable dulness after the almost frantic rush preceding Christmas. Nowhere else in the country is "hard times" so severely felt than in this manufacturing district, the region of strikes and wage reductions. Notwithstanding a cheerfulness assumed by the leading members of jewelry firms in the city, it is unanimously agreed that a couple of years must elapse before the reflex action of good old times can be felt. Idle mills and prospective strikes are still a menace to trade, and until difficulties are adjusted and mills are working, a more or less inactivity will prevail. The past few months show a decided increase in the amount of business done, and while a few of our leading firms hesitate to assume a prophetic role the majority predict better times.

G. B. Barrett, of G. B. Barrett & Co., says: "Collectively, business during the past month has been much better than that for the same month in 1893. The increase in the volume of goods has been marked, although the quality of goods sold has more of a tendency to the medium priced. The outlook for 1895 is fair. I cannot say that it is of the brightest, but there is a better tone."

Mr. Hill, Goddard, Hill & Co.: "Our business returns for 1894 have been considerably over those of 1893. In the sale of watches we found a decrease; diamonds, fair; in sterling silverware the demand was greater than ever before; flat ware, no great demand; clocks and bric-à-brac, medium. The prospects for the coming year can scarcely be stated so early in the day."

Mr. Hartman, West, White & Hartman: "Our business, being in its infancy, has been surprisingly satisfactory. The watch trade is better than expected. Silver is quiet, the big trade being in silver novelties; jewelry in general is good. We cannot expect a big trade this Spring owing to the number of idle works, but the prospects over those of 1894 are manifestly brighter."

S. F. Roberts, E. P. Roberts & Sons: "The returns for the past year are away over those of 1893, the sale of watches and gold jewelry being excellent. Many diamonds were sold, but not of the high priced kind. The silver trade was something phenomenal—novelties, certainly, had the call. We did nicely in bric-à-brac, while flat ware was disposed of in large quantities. The outlook is a brighter one, but 'nothing startling.'"

H. Cerf, M. Bonn & Co.: "We are much pleased over our returns for the past year, and, while we can not give figures, we can cheerfully assert that business is better and the prospects for 1895 more enlivening. We sold a larger number of diamonds than we expected."

J. C. Grogan: "The business returns of the past year are a token of a brighter future. The city trade being upheld by manufacturers and their employes, must naturally suffer. In high priced watches my trade was fair; diamonds, good, having sold many high priced ones. In silverware, sterling, we had an excellent trade. The coming year's prospects I leave 'in the hands of my friends.'"

Harvey Wattles and Charles Wattles, of W. W. Wattles & Sons: "We had an excellent sale in watches ranging in prices from \$70 to \$200. Diamonds, very good, but not so great a demand as in '93. Bric-à-brac we found quiet as sterling silver had the preference. Thus far we can state that 1895 appears much brighter for the trade than 1894."

Kingsbacher Bros.: "Our receipts for '94 are considerably above those of '93, and during the past week we have made some very large sales. We found the demand for silverware to be exceptionally good, like-

wise a fair call for clocks. Watches and diamonds were largely sold."

D. Lloyd, Sheaffer & Lloyd: "We found that 1894 brought in larger returns than 1893, but the prospects for 1895 are, as yet, in the dark. That is, it is not safe to predict. In watches, medium priced, we had good sales; diamonds, larger sales; sterling silver had the lead; flat ware, clocks and bric-à-brac, fair."

John Roberts: "I am very well satisfied with the total receipts of the year, and found a surprisingly large increase over last year's. I can safely say that the sale of diamonds was four times better than in 1893. The silverware demand was immense; bric-à-brac holds its own, while of watches and clocks we sold many. The outlook for the coming year is most auspicious."

R. Siedle & Sons: "In comparison 1894 has been much better for the trade than 1893. As to the prospects for this year we cannot say. Of watches we had a good sale for cheap and medium priced ones; silverware, fair demand for plated ware, while sterling goods had the call; diamonds, very good sale—we sold many large ones; clocks fair."

## 1894 the Dullest Year in the History of Fort Wayne.

FORT WAYNE, Ind., Jan. 2, 1895.

The hard times have, perhaps, dealt more leniently with this place than with the average city of its size. Our good fortune is to be attributed to the conservative policy of our business men, which forbade their indulging in doubtful enterprises or pushing business beyond the margin of safety. As a result, the panic found us with a fair proportion of ready money in hand and only a moderate amount of liabilities. Still, there is here a large population of laboring men, and several hundred of these lost their positions during the great strike last Summer. Business in general has shown a very gradual improvement since about October, but the jewelry trade was one of the last to feel the reviving influence. THE CIRCULAR correspondent visited nearly every jeweler in this city, and, without exception, they say that the year 1894 was the dullest in their experience. Beginning with the first days of December the trade began to improve, and the holiday trade has greatly surpassed all expectations.

August Bruder says that his sales for the holidays were more than double those of the corresponding season of 1893, and were even slightly greater than in 1892. There was an unusual call for articles of large value, such as diamonds and gold watches, but also much demand for cheaper articles. He thinks the prospect for 1895 very good.

Green & Probasco report a good holiday trade but the principal run was in silver novelties and in the cheaper varieties of goods. They think the prospect for the coming year good if other business improves.

Trenkley & Scherzinger make substantially the same statements. Holiday trade was much larger than last year, with a strong tendency toward the cheaper varieties of jewelry.

Henry C. Graffe says that his holiday trade was very large in all lines. The more expensive articles, such as diamonds and gold watches, were in more than usual demand, and the same is true of the cheaper articles.

## Montreal Dealers Did a Good Business.

MONTREAL, Can., Jan. 3.

The holiday retail trade in Montreal was as good as the average in spite of the times. Henry Birks, of Henry Birks & Sons, said that their trade showed a substantial increase over that of the corresponding season of last year. The special feature during the season was the great sale of inexpensive goods. The

cash sale percentage was fully 15 per cent. ahead of last year and the favorite lines were silverware and novelties.

"As for credit trade," he said, "I see very little difference as compared with last year. Of course we had to refuse some accounts. We employed 51 hands during Christmas week, and a private detective to keep ourselves from being robbed. I may say that that last precaution saved us a good many dollars, as he spotted several people in the act of lifting goods."

Richard Helmsley said that trade in his locality was very good. "We had a good demand for diamonds and our call for cheap goods was behind that of last year."

## Jewelers of Utica Hopeful of a Good 1895 Trade.

UTICA, N. Y., Jan. 5.

A casual review of the trade among the jewelers of this city during the year just completed, including their holiday business which under the existing circumstances of general financial depression, was a pleasant and profitable surprise to the merchants, brings this fact to view, that the year 1894 will long be remembered as one of the most unprofitable in the history of the trade in Utica. The general tenor of the merchants' remarks on the subject is that during the year business was very spasmodic, with a decided depression during the Summer and Spring months, gaining somewhat in September and October, then dropping off until the first, and, in some instances until nearly the middle of December, when trade renewed wonderfully, many of the dealers reporting an unprecedented Christmas business. The prospects for this year are good, there being many indications for a much more substantial trade than characterized last year's business. Here is what some of the leading jewelers say concerning the above:

A member of the firm of Joseph Wineburgh & Sons said that the business of the year was not equal to that of the two previous years. There was scarcely any difference between that of 1893 and 1894, although in the former year trade was more uniform. Last year the bulk of the business was consummated in the month of December. The holiday trade was very large and in excess of the previous year. Buyers confined their purchases mainly to novelties, mostly of silver, and for that matter small articles were very salable. There were few purchases for substantial amounts, the exception being in favor of diamonds, there being a small trade in that direction.

Wallace B. Wilcox told me that he had no cause to complain of the business of 1894. While trade has been rather spasmodic, it has averaged well with that of former years. Along some lines it had increased. Mr. Wilcox said that he did not think that his holiday trade would fall below that of 1893, but would about equal it. His sales were, in many instances, for liberal amounts, there being numerous calls for jewelry of a good quality for which high prices were paid. Diamonds and watches predominated. On the whole, this dealer expressed himself as being pleased with the results of the business of the year.

Of the trade for the past year just passed George E. Wheelhouse said he thought the business of his concern had experienced some loss compared with the trade of the year before and others previous. Business was very quiet during most of the months with the exception of October and November when it took an advance. The holiday trade commenced late and this had a tendency to decrease the sales accruing at that season of the year. Trade now appears to be on the increase.

The C. J. Wells Co. report an increase in sales over those of other years almost double. The company make a specialty of watches and have a large trade from the

surrounding towns. Mr. Wells said that the patronage of the working class of people was heavier than it had been in 1893, while there was a decided falling off among his customers from the country district. Silver novelties and small articles were most in demand at Christmas time.

William S. Taylor & Son say that they did a fair business in 1894—doing mostly or as near as possible a cash business, very little credit being given. There were times during the year when it was exceedingly quiet, and then again strengthened, as in the case of the early Fall months. This firm also were affected by the financial condition of those residing in the agricultural districts in this vicinity. Their holiday business was heavy, trade starting in well, and continued so, gaining daily up to the close of the season. The demand was for standard lines of jewelry.

Charles C. Shaver, manufacturer and dealer in silver ware, said to me that he had experienced a very dull year and sincerely hoped that the new year would bring an increase of business. The condition of trade last year was deplorable and heavily felt by all jewelers. The holiday trade was a pleasant surprise, there being a great many purchases made, but principally for small amounts. The sale of small goods was large, with a great call for single spoons and forks and the like, also for lamps.

Charles H. Schiller said that his business last year was at the low water mark. It was much worse than in 1893 and could not compare with trade four or five years ago when it was impossible to get the prices too high to suit the tastes of buyers. The dry goods men are in a measure responsible for the dropping off in custom during the past year or two, as owing to the small amount of money in circulation many not being able to buy goods of a superior quality, purchased those of a cheaper and therefore inferior kind such as the dry goods firms have in stock and with whom the jewelers are not able to compete. Others, however, who wished to have their purchases represent a high class of goods invested in small articles such as sterling silver novelties. He said that this year opened much stronger and brighter than had 1894 and that the signs of the times were strongly indicative of a substantial business during this year.

### Expressions From the Jewelers of Worcester, Mass.

WORCESTER, Mass., Jan. 4.

The condition of the jewelry trade in this city at the present time is summed up in a single statement made by Alvin C. Bruce, of Bruce & Chapin. "The trade," he says, "has reached its lowest point and is now on the increase and by the next Fall will be more like old times."

This statement is the statement of two-thirds of the jewelers in this city, and at the meeting of the State Association of Jewelers held at the Board of Trade rooms in this city, Thursday afternoon, where were present jewelers from all over the State, there was much discussion over the prospects for the future business. They all take a most cheerful view of the outlook, and although some of them predict a dull Spring and perhaps a dull Summer, they look for an old-time boom in the Fall.

With the majority of the trade here the year of 1894 was fully one-third better than 1893. The Christmas trade was unusually good and with the larger dealers it was better than they have ever had. The year 1892 was a good year with all the jewelers, but the year 1893, the first of the hard times, was exceedingly poor and some of them barely got along. The last year was an improvement and one reason for this is that there was not a prominent failure during the year. For the past few years there has been on an average one failure a year among the larger dealers and as a result of forced or auction sales the trade of the regular dealers has been decidedly cut into. The local dealers, after their experience during the year 1893, did not put in a large stock for the past year's trade and some of them did not dare to stock up heavily for the holiday trade, although it turned out to be a prosperous season. The demand during the entire year has been for medium grade goods and the more expensive lines have suffered in consequence.

The optical goods trade is not to any particular extent governed by the holiday season, but there has

been during the past two years a steady increase in this line. The business of opticians is constantly increasing and the demand for optical goods has increased in the same proportion. The following is the statements of some of the principal dealers, made to a representative of THE CIRCULAR:

Frank A. Knowlton: "I feel most encouraged by the year's business. The year 1894 was larger than 1893 by a number of thousands of dollars. The holiday trade was splendid and I sold a great many nice goods. The holiday trade was the best that I ever had. Of course I carry a line of high priced goods, and I was surprised to see the sale that I had on them. It seems that there is a feeling of confidence among the people, and there certainly was more money in circulation. I said that I had the best Christmas trade in my history. I will say that I had one better year. I sold during holiday week an unusual number of diamonds and also sold the same week two oak sets—one of 93 pieces and the other of 73 pieces—and, of course, these run into big money. I see an excellent outlook for the future, as the year starts in well after the Christmas trade, which is usually flat."

W. A. England: "I had a good fair business all the year and the best holiday business that I ever had. There was more money in circulation and, on the whole, the year 1894 was considerably better than 1893. I was stocked up with a general line of medium priced goods and there was a good demand for them, although there was a fair demand for a better class of goods. The prospects for 1895 are good. Speaking of the Christmas trade, I will state that I sold in a single trade, during holiday week, goods aggregating over \$1,200, which is the largest day's sale that I ever had. Taken all in all, the year 1893 was dull and trade was better in 1894. With me the year 1894 was as good as any ordinary year that I have experienced since I have been in business."

Nelson H. Davis: "My business during the year 1894, I should judge, without examining the books, was 20 per cent. less than in 1893. It fell off during the first six or nine months of the year, but the last three months business was good. The December trade was fully 10 per cent. better than the same month during the year 1893 and the Christmas trade was good. I do not think the outlook is for any immediate boom but in the Fall of the present year business ought to be good. It will, in my opinion, take fully six months to show a decided improvement."

Edward Moulton: "My business was a great deal better in 1891 than in 1893 and my Christmas business trade was the biggest that I ever had, but that is accounted for in the fact that I made a special push for it. The outlook for the next year, I think, is good."

Frank R. Hayden, wholesaler: "Six months of the year of 1894 were good and the year as a whole was better than the year 1893, but not so good as 1892, when jewelers were doing a very good business. November and December of the past year were very good and the outlook for the future is much brighter than it was a year ago."

George H. Corbett Co.: "I have been in this store six years but the present firm has been in business two years. The first year we were in business was in 1892, and business at that time was very dull, but the year 1893 was much better and the prospects for the next year even better. The year of 1894 was fully one-third better. The business during the past year picked up in July and has been good since, excepting short intervals, when business was a little dull, and this was expected. During the holiday trade there was a demand for medium grade goods and novelties, and there was no call for nice goods."

Bruce & Chapin: "The Christmas trade was all that could be asked for and we are satisfied. The year of 1894 was some better than the year 1893, and the outlook for the next year is good. We had the largest Christmas trade that we have ever had. The new year's business starts in fairly well. We are pleased with the results of last year's sales and think that the dull times are over. We think that the lowest point in the trade has been reached, and from this time the business will steadily improve."

Herman Lucke: "The trade with me in 1894 was slow, less than the average, and during the year I did not put in a big stock. The Christmas trade was a lit-

tle better than in 1893, but the most of my trade came on the last two days before Christmas. Trade for the next year starts in slow, but that is expected at this time."

J. P. Weixler: "My Christmas trade was better than in 1893, but fell off from 1892, and there have been better holiday weeks than the last. Perhaps, on the whole, the trade for 1894 was a little better than 1893, but not much. The prospects for the future are brighter and I think we will have a better year's business."

Elmer G. Tucker: "My Christmas trade was fully 25 per cent. better than that of 1893, and the past year was much better than the year before. The prospect for the next year with me is good."

England & Leavitt: "There were more customers at Christmas time and money seemed a little more plenty. Trade was as good as could be expected for the holidays. There has been a good, big interest in the trade during the past six months, but the demand has been for a medium grade of goods. The prospects are much brighter."

### Lancaster, Pa., Jewelers Enjoyed a Prosperous Year.

LANCASTER, Pa., Jan. 4.

The jewelry business centered in this city has enjoyed on the whole a fairly prosperous year and look forward to the coming twelve-month with increased hope and confidence. The volume of business has been nearly up to that of former years, but the demand generally was for articles representing less money and the profits as a general rule showed a diminution.

Ezra F. Bowman, of Ezra F. Bowman & Co., said their business for 1894 was ahead of the two previous years, but it had only been kept ahead by going into new fields. General purchasing was much below what it was two years ago. In their manufacturing and engraving department the increase of business was very satisfactory. The outlook for the new year Mr. Bowman considered very encouraging.

Augustus Rhoads said that trade during the year had been fair, and December business very good. The demand, however, was largely for goods of the medium class. The watch trade has been good principally in the cheaper grades. The diamond trade during the year was about as good as in more prosperous years. The clock trade was also good. An indication of the trade was the reviving demand for breastpins and similar lines of jewelry.

Willis B. Musser, of the Non-Retailing Co., said their business in 1894 was ahead of that of the previous year, and memoranda at hand led them to expect a very good trade in the coming year. The increase of their trade in 1894 was all the more surprising inasmuch as the bulk of their trade—watches and chains—were the lines most generally depressed. Since the holidays Mr. Musser said collections had been surprisingly good and a general feeling of confidence seemed to pervade the trade.

### Springfield Jewelers in a Happy Frame of Mind.

SPRINGFIELD, Mass., Jan. 5, 1895.

Springfield jewelers entered upon the New Year in a happy frame of mind, for their inventories, so far as taken, showed an increase of business over 1893 and the prospects for a much better business in 1895. The consensus of opinion among local jewelers is that while the trade was not equal to that of 1891 or 1892—which, by the way, were unusually good years—it was very good. The first half of the year was most discouraging, as a result of the financial depression, but the holiday trade, which began earlier than usual, more than made up for the loss of the first part of the year. But this was true of the city alone, for the surrounding towns and even the city of Northampton report a very small trade. Just what causes this difference in reports is hard to determine unless it be that the people outside of Springfield had more money to spend than usual, and in order to spend it to the best advantage sought the larger cities. Another feature remarked by Springfield jewelers was that more of the middle class purchased goods. This can be easily ex-

plained because of the resumption of work in almost all of the local factories.

F. A. Hubbard said that the past year had been an unusually good one, especially during the holiday season, when his trade not only exceeded that of last year, but passed his most sanguine expectations. He predicted a very bright future for the local jewelers but does not expect more than a gradual increase. His 1894 trade was largely in the better class of goods, especially diamonds.

L. S. Stowe, who is engaged in both the wholesale and retail trade, is very much pleased with his 1894 business and says that his inventory showed an increase of 30 per cent. for the holiday season, although the total sales of the year was about the same as in 1893. In regard to 1895 he thought that the prospects were much brighter, for people have got settled, and there is not the uncertainty that prevailed a year ago.

L. B. Coe said that the most notable depression was felt in the sale of fine watches, while the minor goods, such as silver novelties and the like, were much heavier than ever before. The diamond trade was unusually brisk at Christmas time and very much better than he expected. He, too, was of the opinion that the year just ushered in would be much more prosperous than 1894, and he expects a great revival of the jewelry business.

### Satisfactory Feeling in Omaha Under the Circumstances.

OMAHA, Neb., Jan. 5.

The result of a tour among the jewelry establishments of Omaha is encouraging in the face of much that would seem to make it otherwise. Nebraska suffered severely from the drouth and is still suffering. Her western citizens are crying loudly for bread to keep them alive and clothing to keep them from freezing. Jobbers who sold largely to country dealers from these sections, in the Spring, when the prospect seemed good for a crop, have given up any attempt to collect at present, and are simply doing all possible to tide the retail merchants over to another crop. The improvement in business in the east is begetting a feeling of confidence which will soon begin to show itself in a like improvement here, and with abundant Spring rains, 1,500 miles of irrigating canals constructing and a big manufacturing canal for Omaha, a new era of prosperity will begin.

E. A. Dayton & Co. report trade rather slow and collections slower, particularly in Nebraska, although the volume of business has been about equal to that of last year. They do not expect much revival of trade until Nebraska has a good crop.

S. I. Bergman Co. consider business about as good as last year; have had to strike out somewhat for other fields than Nebraska.

Shook, Patterson & Co. report more orders, but smaller ones. The poor Nebraska market induced them to push into Missouri and parts of Iowa never before reached, and even down into Kansas and Arkansas, and found the new territory better than they could really expect. They will have four men on the road Feb. 1st.

The Van Cott Jewelry Co. report a decided improvement in trade the last few months. While the trade has been fully as good as last year, in fact somewhat better, it has been chiefly in low priced articles, necessitating more work, but bearing a larger margin of profit. This firm has recently moved into larger and finer quarters.

A. Mandelberg reports business fully up to his expectations. The holiday trade was mostly in inexpensive articles necessitating three times as much work, but netting an equal amount. This is the second season for this firm which has grown largely in sixteen months.

A. B. Huberman reports trade better than last year, chiefly in diamonds. They report their business 20 per cent. better than last year. Expect trade will be very dull until next Fall's crop is assured.

John Baumer doesn't want to go through another siege like last year. The jewelry business has been of late confined to a cheaper grade of novelties, and

the department stores do a large portion of that. There is very little money in the country to invest in higher priced goods.

C. B. Jacquemin & Co., Council Bluffs, report a trade that, taking the year as a whole, has been quite satisfactory.

Max Meyer & Bro. Co. find their business satisfactory the past year. They have given up the retail department, and also the musical, confining themselves entirely to wholesale jewelry.

### Two Warrants for Superintendent Hunter of the Elgin Watch Factory.

ELGIN, Ill., Jan. 15.—Two warrants have been issued for superintendent George Hunter, of the Elgin National Watch Co.'s factory, charging him with violation of the factory law as to employment of women over eight hours per day. Deputy inspector Abraham Bisno secured the warrant.

The case is identical with that brought against Mr. Hunter a month ago, and dismissed on the ground that the defendant could not be held responsible for the acts of the corporation. The complaints are made by Amelia and Ida Fischer, who maintain they worked ten hours last Wednesday.

The most precious walking stick in the world is said to be owned by a Dr. Hailes, of New York. The handle is made of a nugget of virgin gold, weighing nearly three pounds, and joined to the stem by a ring studded with 65 diamonds. It is valued at \$3,000.

### The Death of James T. Almy.

NEW BEDFORD, Mass. Jan. 17.—James T. Almy, the oldest engraver and jeweler in this city, and well known as an engraver and optician, died Jan. 12, after a few days' suffering from paralysis.

Mr. Almy was born in Acushnet, Dec. 24, 1824. When a very young child his family moved to Pawtucket, where he passed his boyhood days. He received his education at the Friend's school in Providence, and at the age of 13 came to this city, and became an apprentice to his uncle, the late James Almy, who carried on a jewelry and watchmaking business. A few years later the business was bought by the late George H. Dunbar, and was moved west on Union St. Mr. Almy continuing in Dr. Dunbar's employ. Soon after he established a business of his own, and has been well known as an engraver and jeweler for the past half century.

Mr. Almy was a birth-right member of the Society of Friends, and was also a member of Star in the East Lodge of F. & A. M., and Adoniram Chapter, R. A. M. He was remarkable in the possession of a fine artistic temperament and an extraordinary mechanical ability, a combination which made him exceptionally successful in his avocation. His sterling integrity and unassuming demeanor earned for him the unbounded respect of his fellow citizens.

**FERD. FUCHS & BROS.**  
**SILVERSMITHS,**  
MAKERS OF STERLING SILVERWARE,  
808-810 Greenwich St., New York.

**Jules Jürgensen**  
OF COPENHAGEN.

*The reputation these watches have maintained for Fifty Years has never been equalled, being made on strictly scientific principles and no expense spared to give the Best results in mechanism and timekeeping qualities.*

SOLE AGENTS  
**John G. Hyde's Sons.**  
NO 22 MAIDEN LANE

**A. J. COMRIE,**  
AUCTIONEER,

22 John St., N. Y.

SPECIAL SALESMAN OF WATCHES, DIAMONDS,  
BRIC-A-BRAC, FOR ESTABLISHED JEWELERS.  
— WRITE FOR PARTICULARS. —



**ONE TRIAL**  
OF OUR WORK ON REFINING OF  
ALL KINDS WILL CONVINCe YOU  
THAT OUR RETURNS ARE THE BEST



**CONVINCE YOURSELF.**  
**GEO. M. BAKER,**  
Gold & Silver Refiner  
and Sweep Smelter,  
PROVIDENCE, R. I.

**HAVE YOU RECEIVED OUR PRICE LIST?**  
— OF DIAMOND MOUNTINGS. —

If not, send your business card and we will send you one.



**LEONHARDT & CURRAN,**

Manufacturing Jewelers  
OFFICE AND FACTORY,

57 Maiden Lane, New York.

### The Death of Bathuel Ranger.

BRATTLEBORO, Vt., Jan. 17.—A well-known figure in the business life of Brattleboro passed away Jan. 15, in the sudden death of Bathuel Ranger, 73, senior member of Ranger & Tbompson, who, with a record of 59 years of continuous service, was among the oldest jewelers in New England. Mr. Ranger was in the store all day Saturday, but Sunday he was attacked with neuralgia in the left side. It was soon evident that his condition was serious, and the end came suddenly through weakness of the heart.

Mr. Ranger was born in Colrain, Mass., the youngest of a large family. He came to Brattleboro in 1836 to learn the jeweler's trade with the late Deacon B. Thompson, whose father, Isaac Thompson, had established the business in 1817. The store was in a small building on the site of the present Ranger & Tbompson block. This store was afterward moved to the Hall building, where Hooker block now is. Since 1851 the store has been in its present quarters. Mr. Ranger was admitted to partnership with D. B. Thompson in 1843. D. B. Thompson died in 1876 and soon after his son, Henry

H. Thompson, became Mr. Ranger's partner, under the firm name of Ranger & Tbompson, the style previous to the death of the elder Thompson being Tbompson & Ranger.

Mr. Ranger was married 44 years ago to Miss Abbie S. Wheeler, who survives him. They have no children. Mr. Ranger was a man of quick, penetrating mind, who discussed all public questions with brightness and sound sense. In his business life he was a man of strict integrity, and has enjoyed the esteem of all during his long career.

The funeral was held at St. Michael's Episcopal Church this afternoon at two o'clock.

## DIAMONDS.

# Wm. S. Hedges & Co.,

## Importers of Diamonds,

And Manufacturers of DIAMOND JEWELRY.

170 Broadway, New York.

22 Holborn Viaduct, London.

## Alfred H. Smith & Co.,

IMPORTERS

# DIAMONDS

AND

## PRECIOUS STONES,

182 BROADWAY, COR. JOHN STREET,

NEW YORK.

83 Holborn Viaduct. London. E. C.

## R. A. KIPLING,

### Precious Stones

### AND Fancy Goods

Bought and Sold on Commission.

19 RUE DROUOT,

PARIS, FRANCE.

North East corner 19th St. & 5th Ave.

First Floor, 25 x 100 feet, all light.

SUITABLE FOR MANUFACTURING PURPOSES.

To Let at very low rent. Inquire

A. BARR, on premises.

No jeweler or watch repairer should be without a copy of "WORKSHOP NOTES," a new and very useful book for the workshop. Send for circular containing a complete index of the book, and judge of its merits for yourself.

# OPPENHEIMER BROS. & VEITH,

35 MAIDEN LANE, - NEW YORK.

CUTTERS OF

DEALERS IN

# DIAMONDS, WATCHES.

HAMPDEN MOVEMENT, DUEBER CASES A SPECIALTY.

### A Package of Diamonds Tampered With While in Transit.

COLUMBUS, O., Jan. 18.—A package of diamonds in transit to Harrington & Co., jewelers, of this city, from Koch, Dreyfus & Co., 22 John St., New York, shipped on Jan. 11th, was tampered with. The package was received by Mr. Harrington, but in a far different condition from that in which it left New York. It had been opened and some of the most valuable of the diamonds were missing.

There were three papers of the stones in the package. From one paper four of the nine diamonds were missing, and from the second paper two of the three stones were gone. The third paper had not been opened. The value of the entire lot of the diamonds was \$3,000, and of those stolen about \$800.

Koch, Dreyfus & Co., who were shown the above dispatch, stated to a CIRCULAR reporter that facts contained therein were practically correct. The firm are insured in the Jewelers' Safety Fund Society, which they notified of the theft. Secretary Ira Goddard, of this organization, said that the express company by whom the goods were shipped would probably be held liable for the loss.

### Four Charges Against Jeweler Harris Cohn.

READING, Pa., Jan. 16.—Harris Cohn, a jeweler, residing at 346 Cedar St., has been sent to jail in default of bail to await trial on four charges. For about five years Cohn lived with Miss Rebecca Broodsky and, it is alleged, introduced her to his friends as his wife. Cohn's legal wife arrived from Austria this week with her four children and took up quarters with Cohn.

When Miss Broodsky learned of the new order of things, she went to secure her clothing and jewelry in Cohn's possession and alleges that she was assaulted. As a result she went before Alderman Eby and swore out three warrants, charging Cohn with adultery, larceny and assault and battery, and J. C. Luden, a jeweler, of 706 Penn St., had another warrant issued charging Cohn with larceny. Cohn could not furnish bail and was locked up.

**Fashions in Jewelry and Silver Articles.**

**A LADY'S RAMBLES AMONG THE JEWELERS.**

The beast and bird mania continues. The saw tooth bread knife seems to be a success.

Tailors make a special buttonhole for the middle bar of the man's chain.

Crystals are cut into horse heads, steeple-chases, coaches, and all sorts of horsey pins.

Golf makes its appearance in a new charm. This is a bag in which the jeweled sticks are carried.

A Pomeranian brooch signifies a spitz dog in diamonds. A collie brooch does the same honor to the collie.

The conservatory trowel is a dainty affair with silver or ivory handle, to work among the pots and window boxes.

Gun metal is being used abroad in card cases embellished with a monogram in gold and it is said with excellent effect.

An English woman has brought over a tray of French morocco which contains a clock, a calendar and a thermometer.

A number of women have been asked if they like their knife blades ornamented, and they say: No! The ornamentation makes them look cheap.

Napoleon bronzes are announced, meaning busts of the great captain in the different stages of his career. Napoleonic fans, another name for Empire fans, are also among the novelties.

The proper things to anchor a key chain are the latch key, first of all, a pencil case and a knife with a corkscrew. There are men who attach card cases, cigarette cases. This seems absurd for the trousers pocket.

A pie dish, for the purpose of serving mince pies without chasing them from the pan to the tablecloth before they reach the serving dish, has been invented. Instead of a knife there is a prong, which is warranted to pierce the lightest pastry without breaking it.

It is said that Turkish baths occasionally reveal gold necklaces hung on the necks of men. Bracelets are more common. Some wear bone and ivory studs in preference to gold and carry silver and steel watch chains. The thumping seal on the chain has given way to a quaint coin Indian, or a spade guinea.

ELSIE BEE,

MARKED DOWN.

A Rochester woman recently saw, in New York, a beautiful old French clock, and has often since expressed her wish to own it. Yesterday, when the family distribution was made, she found among her gifts the measliest kind of a toy clock, which, upon being opened, disclosed an owl upon its perch. This choice gift bore a card inscribed: "Louis XIV. clock; marked down from Louis XVI." — Rochester Democrat.

ESTABLISHED 50 YEARS.

LANDEL, BAREMORE & BILLINGS,

IMPORTERS OF

DIAMONDS,

AND OTHER PRECIOUS STONES.

FINE PEARLS A SPECIALTY.

MANUFACTURERS OF

DIAMOND JEWELRY,

IN THE LATEST DESIGNS.

Diamonds Recut in Modern Styles or Repaired on Premises.

58 Nassau Street,  
29 Maiden Lane,  
NEW YORK.

1 Tulp Straat,  
AMSTERDAM.

1 St. Andrews St.,  
Holborn Circus  
LONDON, E. C.



TRADE MARK.

ESTABLISHED 1841.

CARTER, SLOAN & CO.,

MANUFACTURERS OF GOLD JEWELRY,

No. 15 MAIDEN LANE,

NEW YORK.

A. CARTER JR.  
A. K. SLOAN.  
C. E. HASTINGS.

GEO. R. HOWE  
WM. T. CARTER  
WM. T. GOUGH.

FACTORY, NEWARK, N. J.

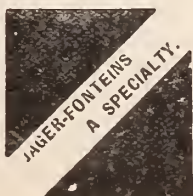

JOHN N. DISSELKOEN,

Cutter and Importer of

DIAMONDS

FACTORY:  
76 LANGELEKERSPAD  
AMSTERDAM

5 & 7 Maiden Lane,  
NEW YORK.

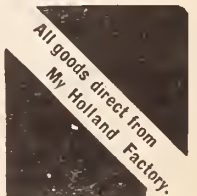

### Maiden Lane's Latest Structure.

Our illustration depicts the latest building of the new and handsome ones erected on Maiden Lane, New York, within the past few years. It is known as the Fahys

have received thorough study on the part of the builders, and on the upper floors in particular both are unsurpassed. Three rapid running Otis elevators will furnish ample facilities in this regard. Heat is



HOW THE FAHYS BUILDING WILL LOOK WHEN FINISHED.

building and occupies the plots numbered 54 Maiden Lane and 29 and 31 Liberty St. The building rises 12 stories above the sidewalk and the material used in the lower portion is granite and Indiana limestone. Above this mottled bricks are used throughout, relieved by courses of terracotta. An artistic ornamental creation of the architect tops the whole.

In the construction of the Fahys building particular care has been taken to resist the action of fire, and in this respect the architects believe it to be the equal of any building in New York city. All partitions are fire-proof. Both the Maiden Lane and Liberty St. entrance halls are wainscoted in marble with mosaic floors. Ventilation and light

supplied by steam and the lighting is by electricity from a private plant embodying all the latest improvements.

The building will be completely ready for occupancy by May 1st, and tenants may lease entire floors or portions of same.

Skillman, Vanderveer & Williams, manufacturing jewelers, Trenton, N. J., have leased the store on the southwest corner of State and Broad Sts. and will take possession on March 1st. The firm will also occupy the upper story of the building, which will be converted into a factory for the manufacture of jewelry and silver novelties, while their show room will be on the ground floor.

### Proceedings of the American Horological Society.

CHICAGO, Ill., Jan. 16. — The regular monthly meeting of the society was held on Wednesday evening, Jan. 9th, President Parsons presiding. Several letters were read from watchmakers throughout the country, asking the board of examiners to publish the correct answers to the questions asked in the November examination. It appeared from the letters that a number of watchmakers, in various parts of the country, had read the questions in the trade journals and had answered them to the best of their ability, and desired to compare the correct answers with their own solutions of the problems, in order to see how they would stand in case they were examined by the board. These letters were turned over to the chairman of the board, who was asked to use his discretion in the matter.

The applications of Leonard S. Bolter, Springfield, Mass., Charles A. Braun, Ottumwa, Ia., Jesse W. Hall, Cazenovia, N. Y., and E. M. Decker, Bloomfield, Ind., were passed upon, and they were elected to membership. Mr. Ashby, chairman of the board of examiners, then reported the decision of the board in regard to the applicants for certificates in the November examination. The committee awarded a certificate to the work marked "No. 1 A" only, the practical work of the other candidates having brought down their averages below 70 per cent., which was agreed on as the minimum average. The applicant "No. 1 A." received 70 points out of a possible 100. The envelopes being opened, it was announced that the successful candidate was A. W. Strickler, 258 51st St., Chicago.

The following inquiry was sent to the "Question Box:"

"Please give a simple rule for determining correct size of a wheel and pinion that is lost."

The question was answered by President Parsons, as follows:

"As it is customary to purchase wheels and pinions ready made in our day, it will not be necessary to go into the theory of epicycloids and the form of cutters for producing them, I will therefore proceed to detail an easy and withal scientific method of ascertaining the correct proportions for a third wheel and pinion when the watch is presented with these parts missing:

First:—We must ascertain the correct number of teeth in wheel and leaves in pinion. We find by count that the center wheel contains 64 teeth, and the fourth pinion has 8 leaves. As every fourth wheel carrying a seconds hand must, of necessity, make 60 revolutions to one of the center wheel, we must so proportion the teeth and leaves of the missing parts as to produce this combination. As it would not be possible to divide 64 by any other figure than 8, without a fraction remaining, we conclude that 8 is the number of leaves in the third pinion, and, if we accept 8 as the number of leaves in the third pinion, we have but one resource in deciding upon the number of teeth in the third wheel. If 8 divides the teeth in center wheel and gives us 8 as the number of times the leaves in the missing pinion are contained in the center wheel, we must conclude that the missing third wheel contains  $7\frac{1}{2}$  times the number of leaves in the fourth pinion, else we could not get the proper number of revolutions of the fourth wheel and seconds hand, or 60 revolutions of fourth to 1 of the center



wheel. Let us work out the problem on these lines and see if we are correct :

Number of teeth in center wheel.....=64÷8=8  
 " " third " .....=60÷8=7½

No. of revolutions of fourth wheel to 1 of center =60 giving us 60 teet in third wheel, or 7½ times the number of the leaves in the fourth pinion, and 8 leaves in third pinion or ⅙ the number of teeth in center wheel. Showing, in brief, that the third wheel and pinion makes 8 revolutions to 1 of the center wheel and the fourth wheel and pinion, 7½ revolutions to one of the third wheel. Multiplied together we have eight times 7½ or 60 as the number of the revolutions of the fourth to one revolution of the center wheel.

Having determined as above the ratio each bears to the other, we are now prepared to find what should be the diameter of a wheel and pinion to work properly in the center distance allotted to these parts. We have learned that the center wheel is 8 times the size of the third pinion, because the numbers of teeth and leaves are in unvarying ratio to the size in all cases, as we shall see further on. For simplicity we will suppose the center distance between the center and third to be 9 m m. If we divide this center distance by 9 (or 8 for center wheel and 1 for third pinion), we have 1 millimeter of the third pinion, leaving 8 millimeters as the pitch radius of the center wheel. If we are certain that the center wheel is correct in size we pay no further attention to it, but proceed to find the proper full diameter of the missing third pinion by the following rule: Multiply the number of leaves (8) plus the addendum, which for pinions is usually 1.25 or 9.25 by the pitch diameter, which is

19.50(2.4375  
 16  
 35  
 32  
 30  
 24  
 60  
 56  
 40  
 40

which gives 2.4375 millimeters as the full size of the third pinion, measured from point of leaf to point of leaf.

Now to find the size of the third wheel by the same rule. We see that it is necessary that the third wheel shall have 7½ times as many teeth as there are leaves in the fourth pinion. This will divide the center distance between third and fourth by 7½ plus 1 or 8½.

We will call the center distances 8 millimeters.

Divided by ratio 7.5 plus 1 = 8.5)8.00(.941+  
 765  
 350  
 340  
 100  
 85  
 15

This gives us .941 as + the pitch radius of the fourth pinion, and as our third wheel must be 7.5 times as large we must multiply our pitch radius of pinion by

.941  
 7.5  
 4705  
 6587  
 70575  
 2

And we have pitch diameter of third wheel = 14 1150

Now to find the full diameter of third wheel we multiply the pitch diameter by the number of teeth plus

the addendum, which for wheels is ordinarily 2.5 thus:

Number of teeth in third = 60.  
 Plus addendum 2.5  
 62.5  
 Multiply by pitch diameter say 14.1 + 14.1  
 62.5  
 2500  
 625  
 Divide by number of teeth 60)88125(14.6875 full diam  
 60  
 281  
 240  
 412  
 360  
 525  
 480  
 450  
 420  
 300  
 300

Hence we have as a result 14.6875 millimeters as the full diameter of wheel (practically 14.7 mm), and for the third pinion, 2.4375 as full diameter.

The above rules are simple and easily mastered, and can be applied to every problem of this kind. I should like to go deeper into the subject and explain something of depthing, etc., but time will not permit. I will, however, give a sample of method, which we use in teaching this branch, for measuring the center distance with the depthing tool. First, set the tool so that the points of the centers enter the jewel hole or bearing perfectly concentric. In other words, strike the center of the holes to be measured from. Hold the depthing tool so that the centers are perpendicular to the face of plate or upright. Next measure over

the centers with millimeter gauge, being very careful that all operations are done with the utmost painstaking, for a very slight error in this measurement will spoil all your calculations. Now measure the thickness of one of the centers and deduct from the distance over all and you have the distance from the point of one center to the point of the other, hence the center distance sought for.

I have endeavored to answer this question in plain terms, that all may understand, knowing that many who need such information are not expert mathematicians, and I believe our mission as a society is to do the most good to the greatest number. Should our friend not get a clear understanding of the subject from these more or less hurried explanations, I shall be glad to explain more fully at some future time. I would say, however, that when once understood, these rules are simple, and take but little time to apply to any case, and in my work, extending over many years, I have found nothing to compare with them for good results in such cases.

Mr. Ashby then explained the uses to which an air ball or bulb can be put to in watch repairing, and the many advantages it possesses over blowing into a movement as practiced by watchmakers generally.

**Missouri Jewelers Want Legislation on the Stamping of Gold Wares.**

St. Louis, Mo., Jan. 17.—The Retail Jewelers' Association of Missouri have sent out a circular of which the following is a copy:

**COPY OF LEGISLATIVE MEASURE DEALING WITH THE STAMPING OF GOLD MANUFACTURES.**

SECTION I. A person who makes or sells, or offers to sell or dispose of, or has in his possession with intent to dispose of, any article of merchandise, marked, stamped or branded with the words, gold or solid gold, 14 K., 18 K. or any other number of karat, or enclosed, or encased in any box, package, cover

**R** J. N. DISSELKOEN,  
**E** FROM  
 19 EAST 16TH STREET,



**M** TO  
 5 7  
**O** MAIDEN LANE,  
**V** NEW YORK.  
**A**  
**L**

FACTORY :  
 76 LANGELEEKERSPAD  
 AMSTERDAM



IMPORTER OF

**DIAMONDS.**

or wrapper, or any other thing in or by which the said article is packed, enclosed or otherwise prepared for sale or disposition, having thereon any engraving or printed label, stamp, imprint, mark or trademark, indicating or denoting by such marking, stamping, branding, engraving or printing, that such article is gold or solid gold, 14 karat or 18 karat, or any other number of karat, unless the component parts of which the said article is manufactured are one part solid gold to each karat, by which the article is marked, stamped or branded, enclosed, encased in any box, package, cover or wrapper, or any other thing in or by which the said article is placed for sale, shall be deemed guilty of a misdemeanor.

SEC. 2. Whoever violates the provisions of the preceding section shall, upon conviction, be subject to a fine not exceeding one hundred dollars for each offence, or be imprisoned in the county jail not more than thirty days.

SEC. 3. This Act shall take effect upon its passage.

#### Election of Directors of the Jewelers' Safety Fund Society.

At the annual meeting of the Jewelers' Safety Fund Society, held Jan. 9th, at the rooms of New York Jewelers' Association, 146 Broadway, New York, the following board of directors were all re-elected: Enos Richardson, of Enos Richardson & Co.; Henry Randel, of Randel, Baremore & Billings; Henry Hayes, of the Brooklyn Watch Case Co.; Wm. R. Alling, of Alling & Co.; Ira Goddard; James C. Aikin, of Aikin, Lambert & Co.; S. C. Scott, of J. T. Scott & Co.; Chas. G. Alford, of C. G. Alford & Co.; Frederick S. Douglas, of Shafer & Douglas; S. Oppenheimer, of Oppenheimer Bros. & Veith; and James P. Snow, of Snow & Westcott.

These directors will elect the officers and executive committee at their next meeting, to be called by the president.

#### Laripp's Clever Swindling Scheme Did Not Work.

HARTFORD, Conn., Jan. 17.—George P. Laripp was arrested yesterday for trying to defraud Barbour Bros. He is wanted in Brooklyn for defrauding the silver plate firm of E. G. Webster & Son, in the same manner in which he tried to victimize Barbour Bros.

His scheme is to go to a silver plate manufacturer and tell him he has a solution which will put a satin finish on silver plated goods. Among the necessary parts of the solution are  $47\frac{3}{4}$  pennyweights of gold and 3 ounces of silver. He asks the company to get the material for the solution, and he will give them a sample of his work. When this is done he invents some excuse for going out, taking the materials for the solution with him. He never comes back.

When Webster & Son had been defrauded in this way they sent out a description of the man and his scheme, to silver plate manufacturers all over the United States.

Walter K. Shearman, of Wheeler & Shearman, jewelers, Penn Yan, N. Y., has been appointed agent for the Ariel bicycles for Yates county, New York.

#### Newton Dexter Turned Down at a Meeting of Massachusetts Jewelers.

BOSTON, Mass., Jan. 17.—The retail jewelers of this city and vicinity held their adjourned meeting to-day at the Boston Chamber of Commerce and organized, or rather connected themselves with an existing organization, but not on the lines laid down for them by the call which had brought them together. The process by which they arrived at this conclusion was attended with some very interesting, not to say exciting, scenes and incidents.

It was evident from the outset that there was a difference of opinion among those present regarding the advisability of following the lead of Newton Dexter, the organizer who had engineered the meeting held a little over a month ago.

In the absence of Albert N. Wood, who presided at the previous meeting, Samuel J. Byrne, of Wilson Bros., representing the opposition element, was chosen as chairman. The committee on permanent organization which was authorized at the first meeting and instructed to present a list of nominees for officers, submitted their report, which was tabled.

Mr. Byrne then called Mr. Newcomb, of Fitchburg, to the chair and proceeded to arraign and interrogate Mr. Dexter after the manner of a dissecting surgeon with an inquisitorial scalpel. Mr. Dexter refused to answer some pointed questions regarding his salary as secretary of the New York Business Men's Association and other matters which he claimed did not concern the meeting, because they had no bearing, in his judgment, on the matter of effecting an organization such as he had advocated. He admitted, however, that the Dueber-Hampden Co. paid him a salary while he traveled about in the capacity of an association organizer.

Mr. Byrne claimed that the movement started by Mr. Dexter was undertaken by that gentleman in his own interest and not in the interest of the retail jewelers. A motion that those present, except press representatives, who were not retail jewelers be requested to retire, came within two votes of passing.

After the excitement attending this proceeding had subsided Mr. Dexter was granted the floor and spoke in vindication of his motives. He stated that it was evident that there was an element present that did not desire organization. He failed to see what difference it made in whose employ he was as long as the Massachusetts jewelers were organized with a definite purpose and had their own officers. They might elect him counselor or not, as they deemed best. He was perfectly willing to leave the room, but would impress upon them the fact that he had taken the initiative in the formation of their association, in case they should decide to carry the matter to such a conclusion.

Another motion was made and carried, inviting Mr. Dexter to remain, but he with-

drew shortly after speaking and the work of organization went on without him.

Mr. Wilson, of Wilson Bros., called the attention of the members to the fact that there was in existence a Massachusetts branch of the National Retail Jewelers' Association. Jewelers from the western part of the State who had joined it recently were present and would explain its purpose and methods. He did not believe in setting up a rival association, such as had been proposed by Mr. Dexter, but thought they should join the National organization in the interest of harmony. It had been intimated that the opponents of Mr. Dexter's scheme did not want organization of any sort. This was an incorrect impression. They did want organization, but they wanted to be sure they were started right and allied with the most desirable body.

Resolutions were adopted rescinding the vote of Dec. 4th whereby the participants in that meeting decided to organize another Massachusetts Retail Jewelers' Association and it was voted that the meeting of to-day favored an alliance with the Massachusetts Branch of the National Retail Jewelers' Association.

*Whereas*, The National Retail Jewelers' Association has been in existence for several years, with State associations now in Pennsylvania, Ohio, Missouri, Illinois, Alabama, Mississippi, New York, Iowa, Kansas, Wisconsin and Massachusetts, and

*Whereas*, The alleged object of the said National Retail Jewelers' Association is the correction of trade abuses and the protection of the retailers, therefore,

*Resolved*, That the establishment of a rival association in Massachusetts would tend to discourage those who are, we believe, working honestly and earnestly in our behalf.

*Resolved*, That the movement inaugurated by Mr. Newton Dexter is suggestive of an advertising scheme for the benefit of a certain manufacturer in whose employ Mr. Dexter has recently been.

*Resolved*, That so far as we have been able to trace the record of Mr. Newton Dexter, we do not consider him a fit person to entrust with our affairs or to represent us in any capacity whatever.

*Resolved*, That we hereby reconsider the vote of Dec. 4th, 1894, by which it was decided to organize another Massachusetts Retail Jewelers' Association.

*Resolved*, That we hereby vote to ally ourselves with the Massachusetts Branch of the National Retail Jewelers' Association.

After adjournment the meeting was called to order again by president R. E. Eldredge, of the Massachusetts branch and president A. S. Goodman, of Philadelphia, who was present from the National Association, assisted in the matter of enrolling new members. A number of those who participated in the meeting had previously joined and seven more signed applications and paid the initiation fee. The meeting then adjourned subject to the call of Secretary Newcomb of the Massachusetts branch.

#### R. Wallace & Sons Mfg. Co. to Supply Silver for the White House.

MERIDEN, Conn., Jan. 16.—R. Wallace & Sons Mfg. Co., Wallingford, have received an order for sterling silverware to be added to the service at the White House. The order will be a costly one.

**Death of Edwin A. Robinson.**

ATTLEBORO, Mass., Jan. 19.—The death of Edwin A. Robinson, which occurred at the family homestead on the Old Boston Pike, near Oldtown, Monday night, removed a historic figure from the circle of wealthy jewelry manufacturers who do business in the two Attleboros. His end was quite sudden, he having been ill with bronchial pneumonia but a few days previous to his death.

The funeral was held from the house, on Thursday afternoon, and was in charge of Bristol Commandery, Knights Templar, of which the deceased was a member. Bristol Lodge also attended the funeral. Rev. Fred A. Dillingham, of the First Universalist Church officiated. The impressive masonic ritual was used and the pall bearers were members of the Commandery. There was a profusion of elegant floral pieces. The interment was at South Attleboro.

Mr. Robinson was born in Oldtown in 1842. His father erected the first shop in this vicinity that was exclusively used for the manufacture of jewelry about the year 1800. The building still stands. His father was in every sense a pioneer jewelry manufacturer.

Mr. Robinson's first business experience was as a clerk in a Boston store. In 1862 he went upon a business trip to China. He returned to the Pacific coast and spent about four years in California and Nevada. In 1867 he embarked in business in the old shop at Oldtown, with two brothers, as Robinson & Co.

Three years after he went to Providence, and went into the real estate business. His investments were very fortunate and have since doubled themselves many times over. Fifteen years ago he purchased property at Attleboro, upon which three large jewelry shops now stand, two of which he built.

Mr. Robinson was a member of many fraternal organizations. He was married twice and a widow and five children survive him. The property of the deceased is reputed to be worth upwards of \$300,000.

**The Factory of the Winsted Optical Co. Burned Out.**

WINSTED, Conn., Jan. 19.—A disastrous fire visited the optical works of the Winsted Optical Co. about 7.40 this morning. The fire started from the furnace in the basement. An effort was made to quench it with a couple of shop hose, but this proved impossible, and the fire department was called out. The deep snow and the long, steep hill bore hard against the firemen. The shop is on a level with the lake and there was no water pressure. By the time the department reached the scene the flames had run up the walls to the room above, where there was a double floor, the planks being about 12 inches apart. The flames spread between these two floors, and the firemen had blazes in every corner to oppose with only two streams of water.

The fire worked up and down, and the result was that the building was pretty thoroughly burned out inside before the firemen succeeded in mastering the blazes. The whole inside of the works and all the machinery are destroyed. The damage is estimated at between \$10,000 and \$12,000. There is an insurance of \$8,000 on the machinery, but none on the building. The company will immediately secure other quarters and continue business.

**A Philadelphia Judge Declares all Watch Clubs Lotteries.**

PHILADELPHIA, Pa., Jan. 16.—J. F. Fritz yesterday pleaded guilty, before Judge Hare, to setting up an illegal lottery. Fritz organized a watch club. His custom was to get about 50 or 60 members each to contribute a dollar a week for 50 weeks, under the inducement that a watch would be given away each week to that member of the club who was so lucky as to have his name chosen by lot. Joseph Kelly, a farmer in the Columbia Ave. Market, joined the club, paid up for about eight or ten weeks, and when the collector for the defendant failed to appear for his money he had Fritz arrested.

Fritz had formed other clubs, one of which was known as a wagon club, in which the same principle was involved. Judge

Hare said that all such schemes were, under the law, lotteries. Sentence was suspended, and Fritz was allowed to enter bail for his future appearance, if called for.

**John Nelson, Buyer of Old Gold, on Trial.**

PROVIDENCE, R. I., Jan. 19.—A case of more than usual interest to the manufacturing jewelers, and retailers as well, of this city, has been occupying the attention of the Supreme Court during the past three days and will probably be prolonged for several days more. It is that involving the receiving of gold scraps and clippings stolen from a manufactory here, by a dealer who is suspected of having been engaged in the business for a long time.

John Nelson is a politician of this city, and Representative at Large in the Rhode Island Legislature. He runs a little watch and jewelry store on N. Main St., and there he has, it is stated, been repeatedly purchasing gold stock at prices that would have suggested something wrong. The people he bought this stock from are Felix McLaughlin, an employe of the Waite, Thresher Co., and Wallace J. Wallace, an employe of the Kent & Stanley Co.

Henry G. Thresher, of Waite, Thresher Co., and John J. Butler, foreman of that corporation, testified as to the identity of the stolen gold; the two thieves testified to disposing of the stock to Nelson and the detectives as to arresting the two men, the finding of the stolen property at Nelson's shop and of the latter's arrest. This was the general line of the prosecution.

Nelson made a complete denial of any complicity, that he did not know that the goods were stolen and that he had always dealt openly with the men and lived up to all the requirements of the law as far as he understood them. He was subjected to a searching cross-examination and was afterwards corroborated in the testimony by the statements of other witnesses. The case was continued until next week.

In a destructive fire in Barnesville, O., Jan. 12, the store of McKeever & Stevenson suffered to a considerable extent.

**Jno. W. Reddall & Co.,**

107 HAMILTON ST.,

NEWARK, N. J.

**SIDE COMBS** *in fourteen karat gold.**A great variety of patterns at prices within reach of all.*

# REED & BARTON



SILVERSMITHS

TRADE MARK  
STERLING  $\frac{925}{1000}$  FINE

37 Union Square }  
13 Maiden Lane } New York

"LA MARQUISE"  
DESIGN PATENTED.

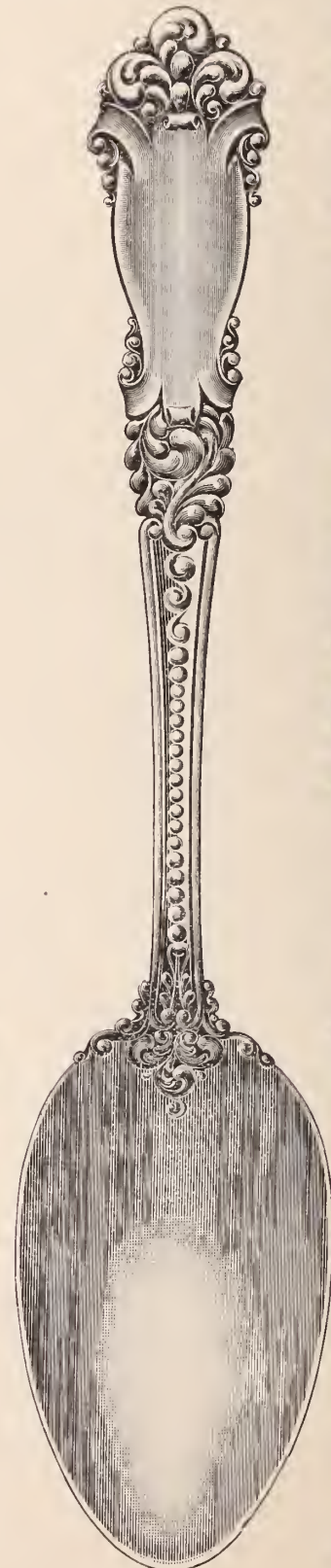
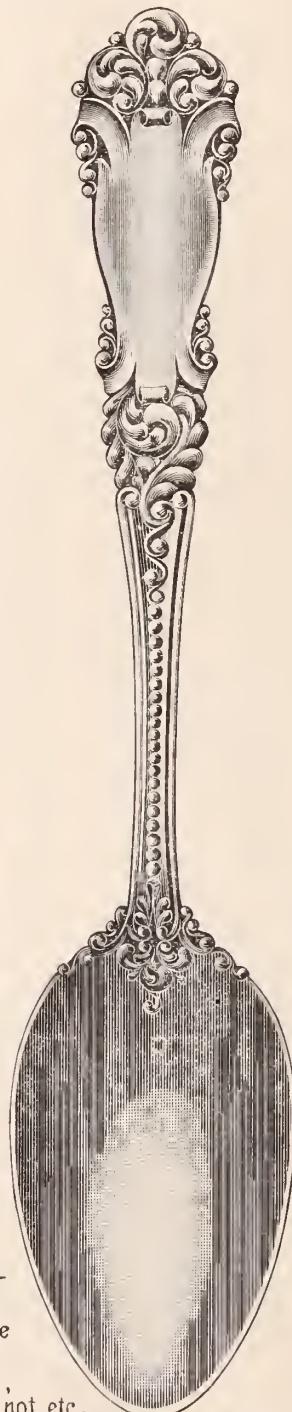
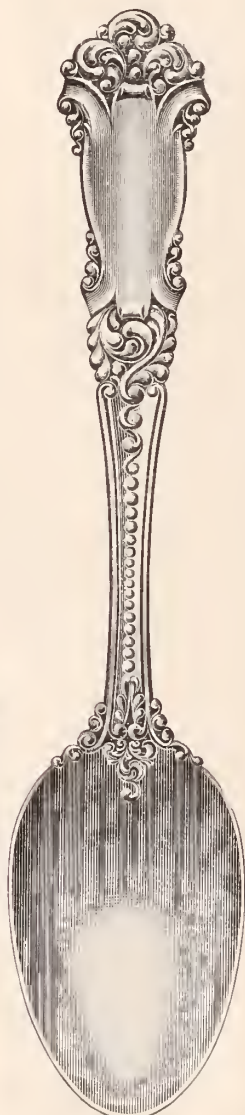
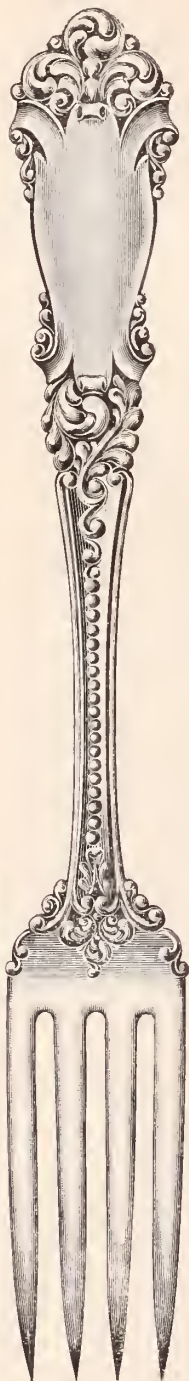
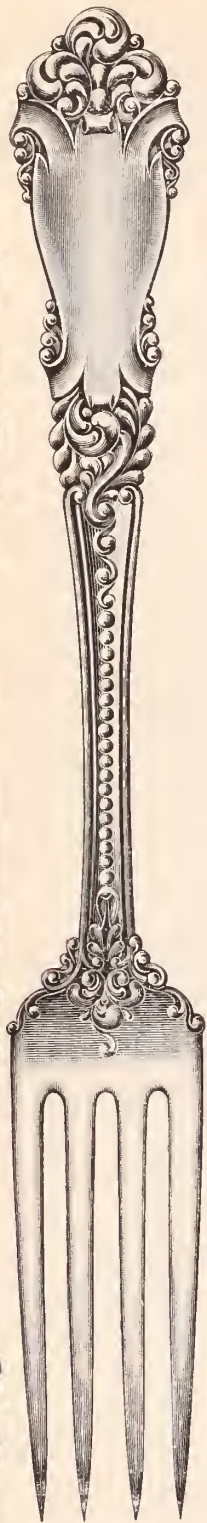

Table Fork.  
Average Weight to the Dozen,  
28 oz.

Dessert Fork.  
Average Weight to the Dozen,  
20 oz.

Tea Spoon.  
Average Weight to the Dozen,  
12 oz.

Dessert Spoon.  
Average Weight to the Dozen,  
20 oz.

Table Spoon.  
Average Weight to the Dozen,  
28 oz.

THE "LA MARQUISE" especially meets the requirements of those of a truly refined taste. The ornamental designs on the reverse side of the different pieces of this pattern show a pleasing variety of FLOWERS including the Orchid, Golden-Rod, Clematis, Wild-Rose, Chrysanthemum, Daisy, Forget-me-not, etc. It is furnished in weights as mentioned under each article, and in heavier weights to order. A complete variety of fancy pieces is made in this pattern, numbering over one hundred and embracing the latest ideas in silver service worked into the most pleasing and practical forms

WORKS  
(AND)  
OFFICES

TAUNTON, MASS.

CHICAGO OFFICE 34 WASHINGTON ST.

PHILADELPHIA OFFICE 225 CHESTNUT ST.

# The Jewelers' Circular

AND  
HOROLOGICAL REVIEW.

PUBLISHED EVERY WEDNESDAY BY

THE JEWELERS' CIRCULAR PUB'G CO.,

189 BROADWAY, NEW YORK CITY.

A JOURNAL DEVOTED TO THE INTERESTS OF JEWELERS, WATCHMAKERS, SILVERSMITHS, ELECTRO-PLATE MANUFACTURERS, AND ALL ENGAGED IN KINDRED BRANCHES OF INDUSTRY.

Our Editorial columns will contain our own opinions only, and we shall present in other columns only what we consider of interest or value to our readers. Advertising matter will not be printed as news.

Advertising rates in THE CIRCULAR are lower, considering the number of tradesmen reached by its large circulation, than in any other jewelry journal.

Notices of changes in standing advertisements must be received one week in advance; new matter can be received up to Monday.

## INFORMATION FOR SUBSCRIBERS.

### Terms of Subscription, Postage Prepaid.

	PER ANNUM.
United States and Canada, . . . . .	\$2.00
Foreign Countries in Postal Union, . . . . .	4.00
Single Copies, . . . . .	.10

New subscribers can commence at any time.

Payments for THE CIRCULAR when sent by mail, should be made in a Post Office Money Order, Bank Check or Draft, or an Express Money Order or Registered Letter. All postmasters are required to register letters whenever requested to do so.

Pay money only to authorized collectors having proper credentials.

Returning your paper will not enable us to discontinue it, as we cannot find your name on our books unless your address is given.

In changing address always give the old as well as the new one. Your name cannot be found on our books unless this is done.

**NOTICE OF DISCONTINUANCE.**—We will continue to send papers until there is a specific order to stop, in connection with which all arrearages must be paid; but such an order can be given at *any time*, to take effect at the expiration of the subscription. All such orders will be promptly acknowledged by mail.

**PAPERS RETURNED ARE NOT NOTICE OF DISCONTINUANCE.**—The Courts have decided that all subscribers to Journals are responsible until arrearages are paid in full and an order to discontinue has been received by the publisher.

Member of the American Trade Press Association.

Vol. XXIX. Jan. 23, 1895. No. 26.

*Every line of reading matter in THE JEWELERS' CIRCULAR, with the exception of the few brief extracts from exchanges always properly credited, is written exclusively for this journal. Each issue of THE JEWELERS' CIRCULAR is copy-righted.*

THE publisher of a weekly journal is not expected to perform the feats of his brother who issues a daily newspaper. Yet sometimes the former equals his rival in his performances, a notable instance being the publication in THE CIRCULAR, last Wednesday morning, of a full report covering three pages of the annual meeting of the Jewelers' League, held the previous night. Considering the circumstances surrounding the two branches of journalism, this feat of THE CIRCULAR far excels that of a daily newspaper when it publishes an important news "beat." But the meeting was an occasion worthy the effort, and THE CIRCULAR is compensated in the knowledge that it was first to furnish thousands of readers with a full

and fair account of proceedings deeply interesting to them.

WHEN president Dutee Wilcox, of the Manufacturing Jewelers' Board of Trade, at this organization's annual banquet, requested those present who had been connected with the jewelry business for 50 years or more, to stand up and five responded, and those of 40 years' career to do likewise and 25 responded, surely there was an evidence that the goldsmith's is an ancient and honorable craft. Why should not these 30 gentlemen organize themselves into a body to be known by some title such as Ancient and Honorable Order of Goldsmiths?

**Silver Stamping Legislation Rapidly Progressing.** THE following report of correspondence tells its own story, and requires little comment aside

from a repetition of the fact that the measure drafted by THE CIRCULAR, aiming to regulate the stamping of silver manufactures, is meeting with hearty approval among the jewelers and legislators of the several States:

LITTLE ROCK, Ark., Jan. 16, 1895.  
THE JEWELERS' CIRCULAR PUB. CO.

GENTLEMEN:—Your "Silver stamping bill" was submitted so one of our young representatives from this county. He is a bright, hustling attorney and one of our coming men and in his hands the measure will have justice done it if possible. We append you his reply to our letter when we sent him the bill.

The changes in the wording he mentions consist of titles, such as, "Be it enacted by the General Assembly of the State of Arkansas," etc., etc., necessary before presenting to the august body. Our Legislature convened Monday, Jan. 14. Will keep you posted in regards bill.

Respectfully, SPOTT & JEFFERSON.

The letter of the State Representative was as follows:

LITTLE ROCK, Ark., Jan. 15, 1895.  
Messrs. Spott & Jefferson, City.

DEAR SIR:—I have before me a copy of the silver stamping bill. I can find nothing in it but what is just and equitable. I think no one should obtain money under false pretenses. To sell an article as solid silver when in fact it is not seems to me to come under this head. I shall make a few changes in the wording of the bill and then I will take pleasure in introducing the same in the present house and give it my strongest support.

I desire to thank you for your suggestion of this wise measure. If you have any other to offer, I will be glad to receive it.

Very truly yours, JAMES A. GRAY.

Among the Letters to the Editor will be noted additional correspondence bearing on the same important subject of silver stamping legislation which bids fair to become universal throughout the Union,

**Guessing Matches** AS jewelers, to as great extent as other merchants, perchance,

**Are Lotteries.**

aim to advertise their business by instituting guessing matches of various character, the following decision of the Assistant Attorney General bearing upon the subject will prove interesting:

"First—The awarding of a prize to the person guessing nearest the number of seeds in a watermelon would be a lottery.

"Second—The awarding of a prize to the person guessing the nearest number of beans in a clear glass bottle set in plain view would be a lottery. I have, in a few instances, held that such a scheme is not a lottery, but upon a maturer consideration I am now satisfied that it is. To remove the chance element from such a scheme, the size of the vessel and the exact size of each article in it must be given. I mean by size of the vessel, its contents, exclusive of the material of which it is composed. For instance, the contents of the vessel is given, and it is filled with articles of a uniform size and shape, such as shot of a certain number, then the number of such articles may be computed approximately, and if the scheme does not require the exact number to be guessed, but prize is offered to the person guessing nearest the contents of such a vessel so filled, it would not be a lottery. Where, however, beans, corn, oats, wheat, or other grain of variable sizes and shapes are put in the vessel, no such certain data exist as will eliminate the chance feature from the scheme.

"Third—The awarding of a prize to the person guessing the weight of a watermelon, the guess to be made after lifting it, would not be a lottery."

## A Bold Plan to Rob Several Chicago Jewelers Foiled.

CHICAGO, Ill., Jan. 15.—Twenty Desplains St. police officers in citizens' clothes laid around dark alleys and other places during the early morning hours Sunday waiting for a united attack by an organized band of thieves on a dozen jewelry establishments. The expected raids did not materialize, but it was only due to the fact that the gang received information of the preparations by the police for their reception.

During the last week a disreputable gang of five men has been loafing about West-side thoroughfares, and, though the police fancied they meant no good, they were not molested. A close watch was kept upon their movements, however, and when the quintet met in a certain saloon on Kinzie St., Thursday night, there were friends of the police not far away. Just what was done at this gathering or how everything was borne to Desplains St. station does not appear, but Friday morning Capt. Gibbons knew that between the hours of midnight Saturday and 6 o'clock Sunday morning the following jewelry houses would be looted: R. Lurie, 121 Madison St.; A. Kaempfer, 146 Madison St.; Joseph P. Wathier & Co., 178 Madison St.; E. Hirschberg, 224 Madison St.; Dolle Bros., 348 Madison St.; J. R. Priesmeyer & Co., 198 Madison St.; Youngdahl & Lilja, 273 Madison St.; Spaulding's, 223 Madison St.; Dart's, 321 Madison St.; J. C. Leppert's, 155 Halsted St.; Williams, 121 Halsted St.

### New York Notes.

Bartens & Rice have entered a judgment for \$54.26 against Wm. H. Nesbit.

The Gorham Mfg. Co. have entered a judgment for \$96 against J. Everett Harler.

The Derby Silver Co. have filed a judgment against Lichtenstein Bros. for \$1,776.47.

A judgment against Benj. S. Wise for \$598.08 has been entered in favor of H. Cent.

A judgment against John B. Garcia for \$169.71 has been entered by the Peters & Cahoun Co.

M. B. Bryant & Co. have been elected to membership in the New York Jewelers' Association.

A judgment for \$1,788.04 has been entered against S. A. Gutman & Co., in favor of Eichberg & Co.

Bloch Ainé has removed from 4 Maiden Lane to the ninth floor of the Diamond Exchange, 14 Maiden Lane.

The Solidarity Watch Case Co., now at 52 Maiden Lane, will about March 1st move to new quarters at 3 Maiden Lane.

John N. Disselkoe, importer of diamonds, Thursday opened his new office at 5 and 7 Maiden Lane, having removed from 19 E. 16th St.

Jno. W. Sherwood, jobber in diamonds and watches, removed last week from 20 Maiden Lane, to the seventh floor of the Stevens building, 3 Maiden Lane.

Edmond E. Robert, importer of watches in the Hays building, 21 Maiden Lane, will remove sometime before May 1st to the Stevens building, 3 Maiden Lane.

The Sheriff, Monday, received an execution for \$477 against Morris Schiff, wholesale jeweler, 30 Maiden Lane, in favor of Simon Sondheim. Liabilities about \$5,000.

The settlement proposed by Frank Bayerdoefer of 40 cents cash is still in abeyance. His liabilities are \$22,603.40, nominal assets, \$16,881.86, and actual assets, \$12,122.07.

The suit in the City Court by A. Lounsbury & Son against the Jewelers' Safety Fund Society has been settled out of court. An order discontinuing the action without costs was entered Jan. 15th.

Arthur Hirsch now represents Koch, Dreyfus & Co. in Virginia, Tennessee, Kentucky and the south Atlantic States. Fred. Diefenthaler will hereafter look after the New York city trade for this firm.

Henry E. Oppenheimer & Co., diamond importers and manufacturing jewelers, 47 Maiden Lane, have leased the entire seventh floor of the Diamond Exchange, 14 Maiden Lane, into which they will remove about May 1st. The factory will remain at the old location, 47 Maiden Lane.

The firm of Seckels & Oppenheimer, importers of precious stones and diamonds, 45 Maiden Lane, dissolved Jan. 15th by mutual consent. Both partners sign in liquidation. Wm. Seckels has started in business for

himself at 41 and 43 Maiden Lane, while Zach. A. Oppenheimer continues at the old address.

The following officers' of the Jewelers' Safety Fund Society were elected, Jan. 18, at a meeting of the directors: President, Henry Hayes; vice-president, S. Oppenheimer; secretary and treasurer, Ira Goddard; executive committee Enos Richardson, Wm. R. Alling, Frederick S. Douglas, Henry Randel, S. C. Scott.

Wm. Moll who recently gave himself up to the police and confessed that he had stolen a quantity of rings from the factory of John R. Wood & Sons, 1322 Atlantic Ave., Brooklyn, where he had been employed, was discharged last week by Justice Goetting, in the Lee Ave. Police Court. His employers did not press the charge.

F. A. Averbeck, of Averbeck & Averbeck, 14 Maiden Lane, is receiving congratulations upon his recent marriage to Miss Georgia Moll, of Chicago, Ill. Mr. and Mrs. Averbeck were married New Year's day at Junction City, Ind., in the private car of J. B. Moll, the bride's father, who is supervisor of the C. M. & St. P. R.R.

Additional judgments against Abraham Schieber whose auction store at 20 W. 14th St., was closed out Dec. 14 on confessed judgments aggregating over \$3,000, were entered last week by the Niagara Silver Co. for \$440.72, and the Con. Fruit Jar Co. for \$555.17. Schieber is said to have been the head of the American Syndicate of Jewelers' Auctioneers.

An original mode of displaying loose diamonds and jewelry is to be seen in the window of Benedict Bros., at Broadway and Cortlandt St. One of the large show cards announcing the seventh annual reception to be given by Palestine Commandery, No. 18, Knights Templars, in Madison Square Garden, February 7th has been used as a basis for the very attractive decoration. Entirely surrounding the large red Templar cross, which occupies the middle of the card, are diamonds of the first water and of large size. Fourteen large stones are placed about the figure of a Knight Templar of the olden times which is in the middle of the cross. The entire card was surrounded by a frame of gold and silver collar buttons. The window also contains a fine display of Masonic emblems.

The General Term of the Superior Court Monday handed down its opinion in the suit of Price against Ga Nun affirming the decision of the trial term which awarded a judgment to the plaintiff. This judgment was awarded the plaintiff, Miss Price, against Ga Nun & Parsons, opticians, W. 42d St., for damages suffered to her eyes and general health alleged to have been caused by a mistake in filling a prescription for eyeglasses.

Simon Black, manufacturing jeweler, 14 John St., made an assignment Friday to Warren S. Burt, without preference. Mr. Black made a fortune, it is said, in Kim-

berly, South Africa, which he lost in a panic in London in 1879. He came to this country later and settled in Philadelphia. He has been engaged in the jewelry business in New York but a few years. Mr. Black is the father of Mr. Bonner, senior member of Bonner, Rich & Co., 41 Maiden Lane. Black's liabilities are estimated by the trade at about \$20,000.

Sometime in the early hours of Wednesday morning, the side pane in the window of the branch store of Mrs. T. Lynch, 1123 Broadway, was either broken or cut through, and jewelry and opera glasses estimated to be worth over \$500 were stolen. The broken window was discovered by the policeman on the beat, who reported it to the 30th St. station, but though detectives were immediately put on the case, no trace of the goods has yet been discovered. Among the articles stolen were a diamond brooch, a heavily jeweled watch, with the case set with diamonds, and 27 pairs of opera glasses. This makes the third window robbery from which this store has suffered.

Bernard Berman, pawnbroker and dealer in diamonds, 2 Oliver St., sold out his pawnbroking business last week to Harris Ablowich, who is now in possession only for the purpose, it is said, of redeeming the pledges, and not to continue the business. Herman Joseph, who represents Mr. Ablowich, is authority for the statement that the latter had paid some cash and extinguished a past indebtedness for the transfer of the business. The liabilities, the attorney states, will probably not exceed \$40,000, principally for diamonds, and the assets are a lot of uncollectable debts. The cause of Mr. Berman's failure is attributed to losses on the sales of diamonds on the instalment plan. Berman's liabilities are estimated in the trade at about \$20,000 more than the figure given by Mr. Joseph. Among his principal creditors are: L. Tannenbaum & Co., Jos. Frankel's Sons, Sig. Hirschberg, M. J. Lasar and H. Schenkein & Sons.

Emil Van Gelder, formerly in the diamond business at 10 Maiden Lane, who on Oct. 7, 1889, skipped out, leaving his many creditors to mourn his absence, is said to be rusticated in the county jail in Syracuse, N. Y., awaiting trial on the charge of forging a number of checks. Van Gelder has lately added the title "Baron" to his name. Van Gelder, about six years ago opened an office at 10 Maiden Lane, under the name H. E. Van Gelder & Son., which he claimed was a branch of the business controlled by his father, a well-known diamond dealer of Amsterdam. At the end of about six months Van Gelder skipped out, leaving creditors whose claims amounted to about \$50,000. His father, who was notified, claimed to have no interest in the son's business. Among Van Gelder's principal creditors were Hodenpyl & Sons, M. J. Lasar, Lewisohn & Co., H. Muhr's Sons, Kuhn, Doerflinger & Co., H. Fera, D. L. Van Moppes & Co. and a host of others.

L. TANNENBAUM & Co.,  
IMPORTERS AND CUTTERS OF

**Diamonds and Precious Stones,**

Cor. Maiden Lane & Nassau St.

**NEW YORK.**

25 Hatton Garden, London.

TELEPHONE, LONG DISTANCE 1959 CORTLANDT.

## Special Announcement.

Mr. L. Tannenbaum begs to notify his customers and the trade in general, that he has largely extended his facilities for cutting and polishing. Hereafter he will cut and polish not only RUBIES and SAPPHIRES, which has been done for the past 15 years with increasing and gratifying success, but

## DIAMONDS

and all other stones which undergo this process.

Modern machinery of the best and most approved pattern, and workmen of the highest class will enable Mr. Tannenbaum to offer, direct from the cutter's hands, that excellent workmanship demanded by American buyers, at

## PRICES THAT DEFY COMPETITION.

Nor will buyers of Diamonds be the only people benefited. Mr. Tannenbaum imported a five years' supply of rough Rubies and Sapphires DUTY FREE under the old tariff. These goods are now being cut and polished and it is very evident that in these particular stones he can make UNAPPROACHABLE PRICES.

New York as the future Diamond Market is not a phantasy. American cutters will be shown an assortment of rough, at prices which will perhaps cause them to believe that this has already been brought about. All arrangements have been made by the firm for enormous shipments of DIAMONDS, EMERALDS, PEARLS, SPINELS, CATSEYES, MELLEES and all kinds of Precious Stones, although to-day the assortment offered by L. Tannenbaum & Co. ranks second to none in this country.

 HIGHEST PRICE PAID for all AMERICAN PEARLS and OTHER PRECIOUS STONES.

## Letters to The Editor.

### M. D. ROTHSCHILD CONGRATULATES THE CIRCULAR ON ITS LEAGUE MEETING REPORT.

NEW YORK, Jan. 16th, 1894.

Editor of THE JEWELERS' CIRCULAR.

DEAR SIR:—I wish to tender to you my congratulations upon the full and fair account which you publish in to-day's issue of the proceedings of the Jewelers' League last night.

If you will continue in this course, I can safely predict that you will help the League and at the same time derive such benefits from your enterprise as you richly deserve.

Yours very truly,

M. D. ROTHSCHILD.

### TIMELY RHYMES REGARDING THE JEWELERS' LEAGUE.

Editor of THE JEWELERS' CIRCULAR:

The agitation necessary to obtain laws that will give countenance and position to those who sell honest goods rather than to those who do not, should warm the feelings of the jewelers toward the Jewelers' League, as it is wholly interested in the jewelers' prosperity, and the feeling should be reciprocal.

#### PLEASANT MEMORIES.

'Tis pleasant to remember,  
'Midst anxieties and cares,  
That you are a member  
Of the Jewelers' League.

'Tis pleasant to remember,  
In season of rest and pleasure,  
That you will get full measure  
In the Jewelers' League.

'Tis pleasant to remember  
The company you have met,  
Friends you will never forget  
In the Jewelers' League.

'Tis pleasant to remember,  
When blessed with rugged health,  
Should evil come by shock or stealth,  
You are in the Jewelers' League.

'Tis pleasant to remember,  
When sickness is your fate,  
That you joined, before too late,  
The Jewelers' League.

'Tis pleasant to remember,  
When Death calls you hence,  
The good you have done,  
The blessings you have won—  
What a full recompense  
To the Jewelers' League!

W. W. S.

### A GOLD BILL IN THE MISSOURI LEGISLATURE.

JEFFERSON CITY, Mo., Jan. 17, '95.

Editor of THE JEWELERS' CIRCULAR:

I enclose copy of Gold Bill which I shall hand to one of the representatives of our Legislature to be enacted into a law in our State. This bill was drafted by our State organization, and put in shape by myself and a friend.

I would consider it a favor for you to look it over, and any suggestions will be cheerfully received and appreciated, however, advise me anyway, if the bill meets with your approval.

Yours truly,

GEO. PORTH,

*An Act to punish the falsely marking or stamping of the karat on any article of merchandise, gold or solid gold, and to prohibit the manufacture and sale thereof.*

*Be it enacted by the General Assembly of the State of Missouri as follows:*

SECTION 1. A person who makes or sells, or offers to sell or dispose of, or has in his possession with intent to dispose of, any article of merchandise, marked, stamped, or branded with the words gold, or solid gold, 14k., 18k., or any other number of karat, or encased in any box, package, cover, or wrapper, or any other thing in or by which the said article is packed, enclosed or otherwise prepared for sale or disposition, having thereon any engraving or printed label, stamp, imprint, mark, or trademark, indicating or denoting by such marking, stamping, branding, engraving or printing, and such article is gold or solid gold, 14k., or 18k., or any other number of karat, unless the component parts of which the said article is manufactured are one part solid gold to each karat, by which the article is marked, stamped, or branded, enclosed, encased in any box, package, cover or wrapper, or any other thing in or by which the said article is placed for sale, shall be deemed guilty of a misdemeanor, and upon conviction thereof shall be fined not less than five dollars nor more than one hundred dollars or by imprisonment in the county jail not less than thirty days.

### THE CIRCULAR'S SILVER STAMPING BILL IN INDIANA.

Editor of THE JEWELERS' CIRCULAR:

We enclose copy of bill our association is endeavoring to have passed by our Legislature. We are working hard for the measure and hope to succeed.

Yours truly,

JULIUS C. WALK & SON.

*A bill for an act relating to the manufacture and sale of articles constructed in whole or in part of gold or silver, or any alloy, or imitation thereof, prescribing penalties and declaring an emergency.*

SECTION 1. *Be it enacted by the General Assembly of the State of Indiana,* That whoever makes for sale, or sells, or offers to sell or dispose of, or has in his or her possession with intent to sell or dispose of, any article or articles constructed in whole or in part of gold or any alloy, or imitation thereof, having thereon—or on any box, package, cover, wrapper, or other thing enclosing or encasing such article or articles, for sale—any stamp, brand, engraving, printed label, trademark, imprint, or other mark, indicating or designed or intended to indicate that the gold, alloy, or imitation thereof in such article or articles is different from or better than the actual kind and quality of such gold, alloy, or imitation, shall be guilty of a misdemeanor, and upon conviction thereof shall be fined in any sum not less than fifty dollars nor more than one hundred dollars.

SEC. 2. Whoever makes for sale, sells or offers to sell or dispose of, or has in his or her possession with intent to sell or dispose of, any article or articles constructed in whole or in part of silver, or any alloy or imitation thereof, having thereon—or on any box, package, cover, wrapper or other thing enclosing or encasing such article or articles for sale—any stamp, brand, engraving, printed label, trademark, imprint or other mark, containing the words "sterling" or "sterling silver," referring or designed or intended to refer, to the silver, alloy, or imitation thereof, in such article or articles, when such silver, alloy, or imitation thereof, shall contain less than nine hundred and twenty-five one thousandths thereof of pure silver, shall be guilty of a misdemeanor, and upon conviction thereof shall be fined in any sum not less than fifty dollars or more than one hundred dollars.

SEC. 3. Whoever makes for sale, sells, or offers to sell or dispose of, or has in his or her possession with intent to sell or dispose of, any article or articles con-

structed in whole or in part of silver, or any alloy or imitation thereof, having thereon—or on any box, package, cover, wrapper, or other thing enclosing or encasing such article or articles for sale—any stamp, brand, engraving, printed label, trademark, imprint or other mark, containing the words "coin" or "coin silver," referring to or designed or intended to refer to, the silver, alloy or imitation thereof, in such article or articles, when such silver, alloy or imitation shall contain less than nine-tenths thereof of pure silver, shall be guilty of a misdemeanor, and upon conviction thereof shall be fined in any sum not less than fifty dollars and not more than one hundred dollars.

SEC. 4. Whereas, an emergency exists, this law shall take effect and be in force from and after its passage.

OFFICE OF  
RETAIL JEWELERS' ASSOCIATION  
OF INDIANA.

INDIANAPOLIS, January 17, 1895.

DEAR SIR: Will you please use your influence with your member to further the passage of this bill. Please acknowledge receipt of this bill for an act.

Respectfully yours,

JULIUS C. WALK,  
*President.*

HORACE A. COMSTOCK,  
*Secretary.*

## Last Week's Arrivals.

**THE CIRCULAR has perfected arrangements for obtaining the names and hotel addresses of all the latest buyers visiting New York, and each day posts in its office, 189 Broadway, a bulletin which every member of the trade is cordially invited to copy.**

The following out-of-town dealers were registered in New York during the past week: A. G. Barber, Boston, Mass., Astor H.; J. Gillespie, Boston, Mass., Astor H.; W. C. Sisco, Chicago, Ill., St. Cloud H.; M. Streicher, Chicago, Ill., Astor H.; J. B. Gifford, Fall River, Mass., Metropolitan H.; I. Sternberg, Savannah, Ga., Morton H.; A. C. Lord, Tilton, N. H., Astor H.; H. Leiter, Syracuse, N. Y., Holland H.; W. J. Barr, Toronto, Ont., Astor H.; E. A. Dayton, Omaha, Neb., Astor H.; R. E. Kehl, Chicago, Ill., Astor H.; M. Kohner, Baltimore, Md., Astor H.; C. E. Wigginton (bric-à-brac for Woodward & Lathrop), Washington, D. C., St. Denis H.; C. H. Jennings, Bridgeport, Conn., Grand Union H.; L. Heller, Chicago, Ill., Astor H.; L. S. Stowe, Springfield, Mass., Astor H.; S. Eisenstadt, St. Louis, Mo., St. James H.; H. L. Phillips, Jamestown, N. Y., Metropole H.; M. S. Levy, San Francisco, Cal., Belvidere H.; A. S. Goodman, Philadelphia, Pa., St. Cloud H.; H. Wineburgh, Utica, N. Y., Park Ave. H.; L. Hill, Chicago, Astor H.; E. Stein, Chicago, Ill., Stewart H.; J. A. Pitt, Montreal Can., New Amsterdam H.; C. Wendell, Oswego, N. Y., Astor H.; C. H. Hancher, Wheeling, W. Va., Marlboro H.; J. Watson, (Panton & Watson) Duluth, Minn., 415 Broadway; J. Neafach, Albany, N. Y., Broadway Central H.; Geo. Greenzweig, San Francisco, Cal., Astor H.; A. Kurtzborn, Jr., St. Louis, Mo., Imperial H.; J. Castelberg, Baltimore, Md., Stewart H.; A. W. Paul, Boston, Mass., Marlboro H.



# THREE POPULAR FAVORITES

## TRILBY,

as a dainty blanchisseuse de fin, won all our hearts. Our new TRILBY Ladies' Chain, wins the heart and admiration, and the cash of every buyer. This is a fact.



## THE GAIETY GIRL

kicked her way into popular favor at once, but is even to-day nowhere near as strong a favorite as our new GAIETY GIRL Ladies' Chain. Have you seen it?



## THE DUCHESS,

with her aristocratic face and bearing, typifies the qualities of our new DUCHESS Chains. They sell at sight.



These are a few of our

many new **GOOD THINGS.**

Among others is a beautiful line of **GUARDS**, plain or with Beads, Pearls or Turquoise; some of the handsomest.....

**RIBBON SEAL FOBS** ever offered, and a line of **SEAL PONY CHAINS** that are **SELLERS**, every one.

We nearly forgot to mention our new **TASSEL GUARDS**. But you won't forget them once you see the goods.

EVERY FIRST-CLASS JOBBER CARRIES OUR LINES.

# W. & S. BLACKINTON,

**ATTLEBORO, MASS.**

### Boston.

M. Myer has returned from Georgia with his bride.

E. H. Saxton has been in Washington during the past week.

Misses Leah and Lizzie Cowan are home from their southern trip.

William E. Clement, of D. C. Percival & Co., was married Jan. 22 to a Somerville lady.

John O. Holden's son, of Quincy, will carry on his father's business and settle up the estate.

E. C. Woodworth, from Boston, Mass., has moved his business to 51 Center St. Brockton, Mass.

W. H. Galloupe, salesman for the Saxton Co., is on a vacation trip to his former home in Battle Creek, Mich.

A. G. Barber, of the Globe Optical Co., was in New York as the concern's representative at the meeting of the American Optical Jobbers' Association.

In the Suffolk County's Insolvency Court Jan. 18, at the adjourned third meeting in the case of Harry W. Oliver, Chelsea, a discharge was refused. The composition case of Alfred H. Marcus & Son was adjourned to Jan. 25.

Buyers in town the past week included: A. S. Gordon, Laconia, W. D. Heath, Lakeport, J. H. Hutchinson, Portsmouth, N. H.; George A. Foye, Athol, Herman Lucke, Worcester, F. A. Robbins, Pittsfield; M. F. Robinson, Springfield, L. R. Hapgood, Westboro, F. M. Nichols, Taunton, Mass.

Carlos D. Smith, known to his numerous friends and acquaintances in the New England trade as "Carl," brother of the senior member of the firm, has been admitted to partnership with Smith & Patterson, and the name of the house will now be Smith, Patterson & Co. The new member has represented the establishment as traveling man for 15 years, and during the past three years has been a buyer of gold and plated jewelry.

A measure which interests the jewelry auctioneers is creating considerable stir among those who conduct auction sales of various sorts in Boston and other cities of the State. It aims at restriction by legislation and proposes an increase from \$2, the present auctioneer's license fee, to \$500, without the power of deputizing. Another feature of the proposed bill is the provision that no sales shall be held between sunset and sunrise. The auctioneers have organized in various lines of business affected and will present a vigorous remonstrance when the subject comes up for discussion in the Legislature.

### Springfield, Mass.

C. Rogers, optician, is planning for a trip through Europe on his wheel next Summer.

The Waltham Watch Tool Co. were awarded a verdict of \$2,094.70 against

the Springfield Mfg. Co., in an action tried last week.

E. D. Burnham has resigned his position in F. L. Tabor's jewelry store, Holyoke, and has been succeeded by Lee Roberts, of Saco, Me.

The will of the late Gustave Young has been filed for probate. The income of his entire estate is to go to his widow and after her death the property is to be equally divided among his children.

The Boston *Globe* of Jan. 20th had a biographical sketch of Wm. J. Brecknell, engraver, who is now employed by F. A. Hubbard. In reciting the history of his life, he tells of some of the fine work he has done. He was born in England and at one time was superintendent of the art department in the big silver works at Birmingham. While in this position he engraved a silver salver, weighing 1,000 ounces, for the Sultan of Turkey and also had the honor of engraving the first piece of work for the Mikado of Japan after Japanese ports were opened to Europe. He also made several elegant and costly pieces for Prince Albert.

### Pittsburgh.

Charles J. Ahlborn has returned from his Cincinnati trip.

Geo. W. Biggs & Co. have improved their store by the addition of Wellsbach lights.

A. J. Reinhart, for many years manager for Jos. Horne & Co.'s jewelry department, died last week. Mr. Reinhart was well-known in the trade here.

The auction sale of R. L. McWatty & Co. has been a remarkable one in every respect, being attended by the society people of the city. The sale will continue a few days longer.

Visiting jewelers in the city last week were: Bert Neville, Dawson, Pa.; E. L. Kennerdall, Kitanning, Pa.; F. Worrell, Washington, Pa.; G. Boss, McKee's Rocks; and W. Brehm, Rochester, Pa.

### Canada and the Provinces.

J. D. Bennett, New Westminster, B. C., has assigned.

S. E. Stephenson, jeweler, Elora, Ont., is in financial difficulties.

The business of Herman Weidman, jewelry, etc., Winnipeg, Man., is in the possession of the sheriff.

M. J. Feeley, representing the Meriden Britannia Co., Hamilton, Ont., is at the Queen's Hotel, Montreal.

Wm. Sloan, jeweler, Milton, Ont., who has been conducting a small business for some years, has assigned.

A settlement of 40 cents on the dollar has been one of the latest achievements of R. Mercer, jeweler, Seaforth.

### Wilmington, Del.

Chas. Rudolph is engaged to be married.

Chas. Heabner has left the employ of S. H. Baynard, as watchmaker.

Joseph Blank, a former jeweler of this city, has engaged with M. Parish, jeweler, Newark, Del.

Wm. Clark, who closed out his jewelry store, 407 Market St., has opened a repair shop at 107 W. 9th St.

Hamilton Ayers, formerly in the jewelry business in this city, is lying very low at his home, and is not expected to recover.

Mr. Davidson, who conducted a pawnbroker's office and jewelry store here for about six months, has sold out at auction.

### Philadelphia.

Edw. Masson has left the employ of the late Rem P. Davies, 116 S. 12th St.

Walter Davis, late with H. Muhr's Sons, has gone with M. Sickles & Sons, 618 Chestnut St.

Salesmen who visited town last week were: C. F. Willemin, T. G. Frothingham & Co.; Mr. Hopkins, Meriden Silver Plate Co.; J. D. Pettingill, Derby Silver Co.

Alfred Britton, alias "Toothpicks," and Frank Leaver, alias "Lawyer," were acquitted of the larceny of a number of unmounted diamonds and two lace pins, valued in the aggregate at \$450 from the store of Jos. K. Davison, 718 Sansom St.

The jewelry store of I. A. Jackemite, 1221 N. 10th St., was entered by a colored thief, who stole jewelry to the amount of \$10.50. The entire reserve squad of the twelfth district officers was called out, but despite the fact that they chased the man some distance he escaped.

Assignments for the benefit of creditors have been recorded as follows: J. G. Rosengarten, Elmer E. Pferisch and William Ettinger, trading as J. G. Rosengarten & Co.; and Geo. J. Dehner & Co. to J. A. Schwartz. The deed is dated Dec. 31, 1894, and conveys no real estate.

Buyers in town the past week included: John Dewar, Bryn Mawr, Pa.; Joseph Lodomus, Chester, Pa.; Howard Fitzsimmons, West Chester, Pa.; Hugo Watson, Manayunk, Pa.; R. G. Porter, Woodbury, N. J.; B. C. Foster, Bristol, Pa.; C. F. Hunsberger, Slatertown, Pa.; Israel James, Sweedborough, N. J.; C. F. Rudolph, Wilmington, Del.; J. I. Doughty, Millville, N. J.

We have before us perhaps the handsomest catalogue ever issued by a file house. Typographically and artistically the volume issued by the Nicholson File Co., Providence, R. I., leaves nothing to be desired. Numerous views of the factory are scattered over the sixty odd pages in the book and, being printed in a rich brown, set off the black of the file illustrations in a most effective manner. Nearly three hundred varieties of files are illustrated in such a manner that one can see the shape, transverse section and cut. There is a short sketch of the company's career, complete price lists and a host of useful information.

## News Gleanings.

J. H. Sweger, Mifflintown, Pa., has sold out.

John C. Demmert, Trenton, N. J., has assigned.

J. J. Ring, Logan, Ia., has given a mortgage for \$300.

G. H. Todd, De Kalb, Ill., has confessed judgment for \$765.

Gus. Hooben, Whittenton, Mass., will retire from business.

James Clegg, Lapeer, Mich., has had a recent loss by fire.

J. T. Thoelecke, Sidney, Neb., has moved to Pocatello, Idaho.

F. C. Forchner, Nanticoke, Pa., is selling out his stock at auction.

T. E. Gonteman, Edwardsville, Ill., has conveyed realty for \$5,375.

Wetherell & Hollister succeed James H. Morse, in Westfield, Mass.

G. E. Davis, Mahaffey, Pa., has a judgment against him for \$1,530.

L. Golding, Plattsmouth, Neb., has given a realty mortgage for \$1,000.

Charles M. Dick, Greenburgh, Pa., has sold out to Sherman Braughtler.

Geo. L. Ackerman, Scranton, Pa., has given a judgment note for \$968.

F. A. Loew, Tamaqua, Pa., has removed to another location in that town.

J. B. Berger & Co., Paterson, N. J., has given a chattel mortgage for \$2,500.

Charles W. Collings, jeweler, Niles, O., has assigned. His assets are small.

J. O. Dudley, of Plymouth, Ill., will open a new jewelry store in Colchester, Ill.

W. S. Banks, of Banks & Banks, Greenwich, Conn., has made an assignment.

Charles D. Stoup's jewelry store, Turtle Creek, Va., was burned out some days ago.

Robert H. Peters, Corfu, N. Y., contemplates opening a jewelry store in Hallstead, N. Y.

A. L. Shiller, jeweler, Avoca, Pa., will be united in marriage, Feb. 12, to Miss Lena Lasenvitz.

George H. Hopkins has embarked in business as a watchmaker and jeweler in Waltham, Mass.

The jewelry store of C. A. Richardson, Eaton, O., has been closed by C. Fenzel & Co., creditors.

John Rovang has returned to Dalton, Minn., from South Dakota, and has opened a jewelry store.

In a fire in Great Barrington, Mass., Jan. 11, J. R. Prinder, jeweler, lost \$1,000; insurance, \$1,000.

The Turney business block, Greensburgh, Pa., has been bought by Adam Fisher, jeweler, for \$25,150.

Bower & Co., jewelers, Williamsport, Pa., will move on April 1 to a large store room on E. Market Sq.

Drews Bros., Holstein, Ia., have given a bill of sale for \$300, and likewise a chattel mortgage for \$588.

E. R. Stevens, formerly with jeweler Chadsey, Wakefield, Mass., has started in business in Lowell, Mass.

The Burbank block, Pittsfield, Mass., suffered by fire Jan. 18. T. H. Richardson, jeweler, lost \$1,000; insured.

Harry J. Hayward, of Lowell, Mass., has entered the employ of Jordan, Marsh & Co., Boston, Mass., as jewelry buyer.

In a fire in State Center, Ia., recently, R. W. Holesworth, jeweler, is reported to have been affected to the extent of \$3,000.

Meinhoefer & Larosh, jewelers, 30 S. 7th St., have moved to 106 N. 7th St., Allentown, Pa., into more commodious quarters.

The marriage of L. W. Mowry, jeweler, Slayton, Wis., and Miss Eleanor Thayer, Mankato, Wis., took place a few days ago.

The store of W. A. Thoma, Kaukauna, Wis., was damaged a few days ago by fire to the extent of about \$1,400; insurance \$1,000.

The sheriff's sale of goods in C. A. Lindsey's jewelry store, Johnstown, Pa., was postponed until 10 o'clock Friday morning, Jan. 18.

K. Smit, Pittsburgh, Pa., has rented the room in the Kuntz building, Washington, Pa., and will open a jewelry store about April 1.

Nels Vingham has moved from Ft. Atkinson, Wis., to Mt. Horeb, Wis., where he will be engaged in the jewelry business with a brother-in-law.

William Eberlee, who has been in the jewelry business at Benton Ill., the last three months has purchased a jewelry store in La Motte, Ia., and will move there.

On Jan. 9 the window of Brown's jewelry store, Barton, Fla., was broken into and 13 watches and a lot of jewelry taken. Loss about \$200. There is no clew to the thief.

A company has been formed in Waltham, Mass., for the manufacture of clock cases. C. P. Nutting, E. Q. McCollester and J. F. McCollester are the parties chiefly interested.

The storeroom of Wm. Glover, Jr., Hazleton, Pa., will shortly undergo extensive alterations. An auction sale, under the supervision of Col. Rutherford, is now in progress.

At Bethlehem, Pa., the sheriff, Jan. 14, sold the stock of jeweler J. K. Rauch, in bulk, to Gen. W. E. Doster who purchased it for Mrs. Rauch. The price was \$1,800. The execution was for \$10,000.

The Churchill Jewelry Co., Pueblo, Cal., have incorporated with a capital stock of \$1,000 to do a retail jewelry business, and borrow and loan money on jewelry, diamonds, etc. The promoters are: Herbert H. Churchill, Edwin W. Davis and Harry P. Vories, of Pueblo.

## Calvin S. Ball Forced to Make an Assignment.

SYRACUSE, N. Y., Jan. 16.—The jewelry store of Calvin S. Ball, 127 Salina St., was closed a little before 5 o'clock yesterday afternoon, just after his general assignment had been filed in the office of the county clerk. This action on the part of Mr. Ball was expected in certain business circles. His credit had not been the best for several months, and the commercial agencies had had frequent inquiries concerning his financial standing. He had not given a statement to the agencies for some time and this served to lessen his credit among the large firms with whom he dealt.

Mr. Ball has been one of the oldest and best known jewelers in Central New York for many years. In recent years he has met with losses through unfortunate indorsements, and this fact led to the assignment for the benefit of his creditors. Mr. Ball was the former owner of several pieces of real estate, but they have been transferred at different times to his wife and daughter. He became involved with the defunct real estate firm of Selleck Bros., and is said to have lost considerable money by indorsing that firm's paper. Since those losses he has been slow in meeting his bills, it is claimed.

In former years Mr. Ball had been looked on as one of the most substantial business men of the city. He conducted his business for several years at the location now occupied by Becker & Lathrop, in Salina St. From here he moved to the Washington St. side of the White Memorial building, and later to his present location in S. Salina St. The last was looked on as a bad change, and he is said to have made no money since.

In the assignment papers J. Douglass Lavette, Mr. Ball's son-in-law, is named as the assignee. He is directed to turn the stock and any other assets into money and after the payment of many preferred creditors, to distribute the remainder pro rata among the other creditors. The last named are chiefly wholesale jewelry dealers and manufacturers in New York, Boston, Providence, New Haven and Hartford. Mr. Ball's liabilities are estimated at about \$25,000 and the assets, consisting principally of the stock in the store, at about \$18,000.

The Merchant's National Bank is preferred in the sum of \$3,500, the amount of four notes endorsed since Nov. 30th by Mrs. Charlotte E. Ball, the assignor's wife, and the First National Bank of this city, in the sum of \$4,300 and interest, the amount of five notes, dated between Oct. 20th and Dec. 24th last. All of these, except one note of \$1,100, dated Oct. 20th, have not yet matured. These preferences to the banks are stated to be valid only to the amount of one-third of the estate assigned. The preferred claims will amount to something like \$11,000.

Mr. Ball is contesting the payment of some of the notes indorsed for Selleck Bros.

## Our Traveling

### Representatives



Traveling representatives may consider these columns open for the publication of any news or items of interest regarding themselves or their conferees.

**M. F. LAURANCE**, the well known traveling salesman for the Spencer Optical Mfg. Co., will soon start out on his regular trip, and hopes all his friends and customers will favor him with their patronage, as in the past.

William E. Cohen, formerly of New York, is to travel south for E. A. Cowan & Co., Boston, Mass.

Edward D. Cole, formerly with W. W. Mansfield, Portland, Me., will represent Smith, Patterson & Co. hereafter, covering Maine and adjacent sections of New Hampshire and Massachusetts.

John H. Patten, for over seven years with C. G. Alford & Co., representing them in New England, has signed for 1895 with D. S. Spaulding, Mansfield, Mass. Mr. Patten will travel in New England, Philadelphia, Baltimore and Washington.

Salesmen visiting the Hub during the past week included: W. D. Elcox, Larter, Elcox & Co.; S. L. Howland, Eisenmann Bros.; C. B. Hancock, Hancock, Becker & Co.; M. W. Potter, J. M. Fisher & Co.; Mr. Mowry, Kirby, Mowry & Co.; George W. Parks, Parks Bros. & Rogers; Irving Smith, Crescent Watch Case Co.; Harry Barrows, H. F. Barrows & Co.; John L. Shepherd, Keystone Watch Case Co.; Mr. Oakman, A. F. Towle & Son Co.; Robert Hamilton, Hamilton & Hamilton, Jr.

Traveling men in Indianapolis last week included: Geo. W. Bunker, for A. Shydecker; C. A. Fraser, Hancock, Becker & Co.; J. S. Platt, Foster & Bailey; J. J. Somers, Thos. Totten & Co.; L. H. Bosworth, Potter & Buffinton; Mr. Fogg, Keystone Watch Case Co.; H. C. Walton, Wadsworth Watch Case Co.; F. W. Trewin, Keystone Watch Case Co.; H. E. Vincent, Simpson, Hall, Miller & Co.; A. B. Chase, G. W. Cheever & Co.; F. N. Vaslett, Fletcher, Burrows & Co.; Mr. Vaslett, E. B. Thornton & Co.; C. F. Willemin, T. G. Frothingham & Co.; Jno. Cross, Dueber Watch Case Mfg. Co.; Jos. Becker, Jos. Fahys & Co.; J. E. Blake, Blake & Clafin; Geo. C. Booth, Hutchison & Huestis; Wm. W. Middlebrook, B. A. Ballou & Co.; W. F. Briggs, and representatives of New Haven Clock Co.; J. T. Inman & Co.; R. Bradley & Son; and H. C. Lindol.

Travelers in Pittsburgh, Pa., last week were: Geo. C. Booth, Hutchison & Huestis; Charles F. Ketcham, Riker Bros.; J. E. Alexander, for Frank W. Smith; H. Nicholson, Flint, Blood & Co.; James E. Blake, Blake & Clafin; A. Fisher, Kraus, Kragel

& Co.; J. M. Morrow, American Watch Case Co.; Fred J. Foster, Unger Bros.; Chas. E. Dorr, Gorham Mfg. Co.; D. Skutch, Waterbury Clock Co.; D. Barker, Empire Cut Glass Co.; Mr. Tinker, for W. B. Durgin; J. A. Granbery, Reeves & Sillcocks; C. A. Marsh, C. A. Marsh & Co.; G. H. Coggsill, Geo. L. Vose & Co.; A. W. Oakley, Thornton Bros.; I. L. Lehweß, for D. R. Corbin; J. M. Torbett, Hall, Elton & Co.; G. S. Melville, Acme Silver Plate Co.; C. F. Willemin, T. G. Frothingham & Co.; G. Hoffman, Ansonia Clock Co.; F. H. Carpenter, Alfred H. Smith & Co.; Mr. Weisz, Illinois Watch Case Co.; A. Peabody; Wm. Dietz, for L. Combremont.

### Providence.

Fred. R. Pennell has given a chattel mortgage to W. F. Main for \$872.

G. R. S. Killam has started in the watch repairing business at 281 Westminster St.

Among the buyers who visited the manufacturers the past week were M. Bonn, Pittsburgh, Pa., and B. Arnstine, Cleveland, O.

The directors of the Manufacturing Jewelers' Board of Trade met Saturday afternoon and transacted considerable routine business.

David J. White, secretary of the Standard Seamless Wire Co., Pawtucket, has been elected president of the City Council of that city.

Since the recent burglary on Friendship St., several jewelry firms have taken extra precautions for the protection of their property by having their places of business properly wired from the Electric Protective Co.

The case of John Hopkins *vs.* Hopkins & Settle was called in the Supreme Court Saturday morning. This is a petition for the sale of attached property. The case was continued for further service of citation on defendants.

The annual midwinter re-union of the New England Manufacturing Jewelers' Association will be held on Tuesday evening, Jan. 29, at the rooms of the Falstaff Club. The efficient executive committee announce that an unusually fine programme, entirely out of the usual run, will be provided, and an excellent time is assured.

William Abrahams, 17 years of age, was arrested by Detective Parker early last evening for having appropriated \$50 in cash and a number of checks from his employers, the Waite, Thesher Co. Abrahams was hired about a fortnight ago as errand boy, and as such was sent last Saturday to the High St. Bank to make a deposit, which consisted of checks and cash, in all amounting to nearly \$1,000. The lad failed to visit the bank or to return to the factory, and the police were notified with the above result. In the Sixth District Court he admitted his guilt, and in \$500 was held for the action of the grand jury.

### Trade Gossip.

John W. Sherwood, 3 Maiden Lane, has continued his custom of presenting the legitimate jewelry trade with neat celluloid cards, containing the yearly calendar. The three which he has presented to jewelers, as souvenirs for 1895, are models of their kind.

Wm. B. Osgood, manager of the Keating Wheel Co., Holyoke, Mass., is in charge of this company's exhibit at the National Cycle Show, now being held at the Madison Square Garden, New York. Mr. Osgood recently returned from Chicago, after attending a similar exhibit in that city.

One of the most successful lines of last year was the sterling silver mounted ebony toilet articles and novelties introduced by Deitsch Bros., 7 E. 17th St., New York. In the new line for this year the trade will find designs not only as salable as their predecessors but unsurpassed in style, finish and artistic conception. A fine assortment of original designs in tortoise shell goods has also been introduced.

A handy souvenir comes from M. L. Roberts, Grand Junction, Col., in the form of a pocket memorandum notebook. The cover contains Mr. Roberts' ad. and the yearly calendar for 1895, while scattered among its leaves are comparative tables of the population of the States and cities of the United States, and the largest cities of the world, electoral and popular vote for President, 1892, interest laws and statutes of limitations of the States and Territories and other interesting and valuable information.

In the fashion notes of last week's issue appeared a paragraph which, in speaking of the popularity of side combs, mentioned that President Cleveland had recently presented his wife with a pair of handsome small combs ornamented with diamonds. These combs, *THE CIRCULAR* is informed, were made by Jno. W. Reddall & Co., Newark, N. J., who sold them to the Washington jeweler from whom they were purchased by the President. They are but one of the many handsome varieties of side combs which Jno. W. Reddall & Co. are now producing.

Under the title, Gruen's Precision Watches, the jewelry trade has been presented with a neatly bound, well printed pamphlet by D. Gruen & Son who recently established their general office in Columbus, O. The pamphlet is a descriptive catalogue for 1895 of the fine watches made by this firm. The opening pages are devoted to information relating to the watch trade in Switzerland and the reasons for the establishment by this firm of their factory at Glashütte, Germany. The remainder of the catalogue is devoted to a detailed description of the Gruen movement of which an illustration of the 18 size is given. Inserted in the catalogue is a large colored plate showing in detail the Moritz Grossman escapement as carried out to the highest technical perfection in Gruen's precision watches,

**The Latest Patents.**

ISSUE OF JAN. 15, 1895.

**532,520. STEM WINDING AND SETTING MECHANISM FOR WATCHES.** ALFRED BARTON, Boston, Mass.—Filed Jan. 15, 1894. Serial No. 496,838. (No model.)

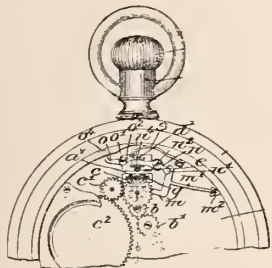

In a stem winding and setting mechanism for watches, a longitudinally movable stem, winding and setting trains, an intermediate winding and setting connection, and an operating lever for the same, an actuating lever for and positively connected to said operating lever and also connected with said stem, inward movement of the latter acting through the said positively connected levers to throw said intermediate connection into engagement with said winding train, and a single spring exerting a constant force tending to throw both the positively connected levers in an opposite direction to move the said intermediate connection into engagement with said setting train.

**532,532. STAFF TURNING LATHE.** DUANE H. CHURCH, Newton, Mass.—Filed Nov. 11, 1893.—Serial No. 490,614. (No model.)

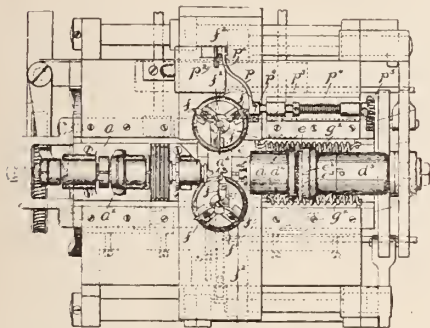

In a lathe, the combination with a rotary work-holding chuck, of a plurality of work-supporting centers in a movable holder whose movement brings said centers severally into axial line with the work while held in the chuck, and means for intermittently moving the holder to bring the centers to such position.

**532,587. JEWELRY.** EMIL SCHILL, Newark, N. J.—Filed July 25, 1894. Serial No. 518,519 (No model.)



The method hereinbefore described of producing jewelry, consisting in first forming a side piece, as *a*, with a design in outline thereon; secondly, forming a center piece, as *b*, thirdly, soldering said center piece to the side piece, so that the upper surface of the center piece and the upper edge of the side piece are flush, and finally forming the cramps on said side piece and said center piece.

**532,680. ENGRAVING-MACHINE.** WILLI-BALD MERL, Cologne, Germany.—Filed Oct. 18, 1894. Serial No. 526,310. (No model.)

**532,695. HAIR-PIN.** MORRILL N. PACKARD Baltimore, Md., assignor of one-half to James F. Morrison, same place.—Filed May 1, 1894. Serial No. 509,685. (No model.)



A hair-pin comprising a sinuous sheath, having a series of perforations arranged in a longitudinal line, and a pin adapted to pass through said perforations in the sheath.

**A Sea Captain Discourses Upon Non-Magnetic Watches.**

**CAPTAIN PATTERSON**, in a lecture recently before the Seawanaka Yacht Club, illustrated by the aid of a large black-board the theory of the various navigation problems, after which he elicited a laugh by stating that he was not in the employ of the firm whose exhibit of non-magnetic timepieces occupied a place on the large table before him. He said:

"In these days of electric lighting plants on board of steam vessels, and where yachtsmen and other navigators are daily moving within the circle of influence of dynamos, of electric ventilating fans, of artificial magnets used for compass correctors, and even that of the trolley car, the question of a non-magnetic timekeeper is one of vital importance. Several years ago I was the proud possessor of a beautiful watch that tallied time almost to perfection, but the mechanism of which I ruined one day by charging the hairspring, balance and pallet with magnetism while handling several bar magnets in the act of adjusting a compass. Although I attempted to have the watch de-magnetized, it never again marked good time, so I discarded it and after a most thorough and rigorous test of the various non-magnetic movements known, I provided myself with a set of Paillard works, and have since by heroic tests demonstrated their wonderful time recording properties, their absolute unsusceptibility to magnetism and electricity and the imperviousness of such non-magnetic metal to corrosion."

The lecturer then made a series of novel and intensely interesting experiments with ordinary watch works magnetized and with the Paillard works, bringing the two movements close to a powerful magnet and showing the stoppage of the ordinary works while the non-magnetic watch ticked regularly and bravely on.

The new rolls being put in the forge room of the Silver Plate Cutlery Co.'s works in Shelton, Conn., are expected, if they prove successful, to work a revolution in the cutlery business in this country. They will do away entirely with the laborious trip-hammer work on knives and by their combination of rolls render the blade ready for the finishing processes. This does away with some of the most irksome of the various processes that a table knife goes through.

**Connecticut.**

The Winsted Optical Co., West Winsted, resumed work on the 21st.

Henry Hall, of the Biggins-Rodgers Co., has returned to Wallingford from a successful trip.

Mr. and Mrs. C. A. Hamilton, of Waterbury, will spend the Winter at the Hotel Majestic, New York.

L. A. Burt, R. Wallace & Sons Mfg. Co.'s traveler, started from Wallingford Jan. 15th on a southwestern trip.

W. F. Rogers, Meriden, addressed the Boys' Club, of that city, Jan. 16th, on "Scenes in My European Journey."

Col. W. J. Leavenworth was re-elected president; L. M. Hubbard, vice-president; R. H. Cowles and W. J. Leavenworth, auditors of the Wallingford National Bank, Jan. 15th.

Col. Watson J. Miller, president of the Derby Silver Co., attended the Old Guard's ball, New York, Jan. 15th, together with Governor Coffin, of Connecticut, and the other members of the Governor's staff.

R. Wallace & Sons Mfg. Co.'s factory, Wallingford, is running full time in many of its departments, and the same may be said of the Maltby, Stevens & Curtiss Co. There are prospects of a good Spring trade among the silver factories.

W. F. Rockwell was Jan. 15th re-elected president and treasurer of Miller Bros. Cutlery Co., Meriden, and C. L. Rockwell was chosen secretary. The directors are the two gentlemen mentioned, G. W. Lyon and Henry J. Lewis, of Stratford.

The Meriden Britannia, Meriden Silver Plate and Wilcox Silver Plate companies, Meriden, started up Jan. 14th, after their three weeks' holiday shut down. The Britannia and Wilcox Silver Plate companies will run for the present on eight hours per day.

William H. Saxton, Jr. has severed connection with the Saxton Jewelry Co., of New London, and has removed to New York, where he will enter the employment of E. E. Orvis, 694 Columbus Ave. Mr. Saxton is a graduate of Woodcock's Horological School, Winona, Wis.

The Derby Silver Co.'s works started Jan. 14th after a three weeks' shut down for inventory, and at present will give about three days' work per week to the full complement of help, the shop running every day with about half the regular force in alternate half weekly trips. This is only a temporary arrangement until the works can be started. The annual meeting of the company was held Jan. 15th. A dividend was voted. The election of directors followed and resulted as follows: Watson J. Miller, William E. Downes, Thomas H. Newcomb, A. R. Smith, Henry J. Smith, Charles H. Nettleton and Charles E. Clark. The directors then met and elected the following officers: President, Watson J. Miller; secretary and treasurer, Wesley S. Clark; superintendent, Thomas H. Newcomb.

# CLASSIFIED INDEX TO ADVERTISEMENTS.

All Advertisements are entitled to one insertion under proper heading. Extra insertions, \$6.00 per annum.  
Extra Headings, \$12.00 per annum.

<b>Art Pottery, Bric-a-brac, Etc.</b>	Page.	<b>Diamond Cutters.</b>	Page.	<b>Ring Makers.</b>	Page.
Bing, Ferdinand & Co., 106 Grand St., N. Y.	36	Fera, Henry, 10 Maiden Lane, N. Y.	34	Bowden, J. B. & Co., 192 Broadway, N. Y.	39
Hinrichs & Co., 29 & 31 Park Place, N. Y.	39	Fox Bros. & Co., 68 W. 4th St., Cincinnati, O.	30	<b>Safes.</b>	
Straus, L. & Sons, 42 to 48 Warren St., N. Y.	35	Oppenheimer Bros. & Veith, 35 Maiden Lane, N. Y.	10	Mosler, Bahmann & Co., 518 B'way, N. Y.	35
<b>Assayers &amp; Refiners.</b>		Randel, Baremore & Billings, 29 Maiden Lane	11	<b>Sample Trunks.</b>	
Baker, Geo. M., Providence, R. I.	9	<b>Diamond Jewelry.</b>		Crouch & Fitzgerald, 161 Broadway, N. Y.	5
Le Long, L. & Bro., Newark, N. J.	40	Jeanne, Paul, Bradley Bldg., N. Y.	36	<b>Show Cases.</b>	
Rathbone, J., 1-9 Mathewson St., Providence, R. I.	39	Leonhardt & Curran, 44½ Maiden Lane, N. Y.	9	Smith, B. & W. B., 220 W. 29th St., N. Y.	40
U. S. Smelting & Refining Works, 25 John St., N. Y.	40	<b>Diamond Polishing Mills.</b>		<b>Silver Plated Ware.</b>	
<b>Auctioneers.</b>		Arthur Co., The, 86 John St., New York	40	Pairpoint Mfg. Co., New Bedford, Mass.	5
Boyle, Davis & Goodman, 63 5th Ave., N. Y., 611 Pennsylvania Ave., Washington, D. C.	29	<b>Ebony Goods.</b>		The Wm. Rogers Mfg. Co., Hartford, Conn.	5
Comrie, A. J., 22 John St., N. Y.	9	Deitsch Bros., 7 E. 17th St., N. Y.	2	Webster, G. A., Chicago, Ill.	29
French, J. H., P. O. Box 2775, N. Y.	34	<b>Fine Stationery.</b>		<b>Sterling Silver Novelties.</b>	
H. M. Rich & Co., 21 School St., Boston, Mass.	5	Parsons & Greene Co., 18 Murray St., N. Y.	5	Codding Bros. & Heilborn, North Attleboro Mass.	38
<b>Badges, Medals, Etc.</b>		<b>Gold and Rolled Plate Jewelry.</b>		Hagan, White & Co., 243 W. 23d St., N. Y.	2
Stockwell, E. R., 19 John St. N. Y.	2	Foster & Bailey, Providence, R. I.	3	<b>Sterling Silverware.</b>	
<b>Bicycles.</b>		Smith, Wm., & Co., 5-7 Maiden Lane, N. Y.	32	Fuchs, Ferd. & Bros., 808-810 Greenwich St., N. Y.	9
Keating Wheel Co., Holyoke, Mass.	38	<b>Gold Jewelry.</b>		Reed & Barton, 37 Union Square, N. Y.	16
<b>Book Marks, Sterling Silver and Gold.</b>		Aikin, Lambert & Co., 19 Maiden Lane	2-35	Towle Mfg. Co., Newburyport, Mass.	32
Stone Bros., 535 Broadway, N. Y.	35	Carter, Sloan & Co., 15 Maiden Lane, N. Y.	11	Wallace, R. & Sons Mfg. Co., 3 Park Place	6
<b>Chains.</b>		Greene, Geo. F., 111-113 Point St., Providence, R. I.	2	Wood & Hughes, 16 John St., N. Y.	36
W. & S. Blackinton, Attleboro, Mass.	21	Larter, Elcox & Co., 21-23 Maiden Lane, N. Y.	36	<b>Tool Manufacturers and Dealers.</b>	
<b>Clocks, French, English and American.</b>		Reddall, John W., & Co., Newark, N. J.	15	Allen, Benj. & Co., Chicago, Ills.	29
Jacques, Chas., Clock Co., 22 Cortlandt St., N. Y.	40	<b>Horological Schools.</b>		American Watch Tool Co., Waltham, Mass.	35
<b>Cut Glass.</b>		Chicago Watchmakers' Institute, Rockford & Chicago, Ill.	29	Moseley & Co., Elgin, Ill.	29
Clark, T. B. & Co., 860 Broadway, N. Y.	35	Parson's School for Watchmakers, Peoria, Ill.	29	Mossberg Wrench Co., Attleboro, Mass.	39
<b>Diamond &amp; Precious Stone Importers.</b>		Philadelphia College of Horology, 623 Heed Building, Phila., Pa.	35	Oliver, W. W., Buffalo, N. Y.	9
Disselkoeen, John N., 19 E. 16th St., N. Y.	11-13	<b>Jewelry, Silverware and Optical Cases.</b>		<b>Thimbles.</b>	
Falkenau, Oppenheimer & Co., 40 Maiden	40	Jackson, S. C., 180 Broadway, N. Y.	39	Ketchum & McDougal, 198 Broadway, N. Y.	39
Friedlander, R., L. & M., Ltd. 30 Maiden Lane, N. Y.	34	<b>Jobbers, Watches, Diamonds, Etc.</b>		<b>Trunks and Traveling Bags.</b>	
Hedges, Wm. S. & Co., 170 Broadway, N. Y.	10	Aikin-Lambert Jewelry Co., 19 Maiden Lane	2-35	Crouch & Fitzgerald, 161 Broadway, N. Y.	5
Kahn, L. & M. & Co., 172 Broadway, N. Y.	40	Myers, S. F. & Co., 48 Maiden Lane, N. Y.	40	<b>Watch Case Repairers.</b>	
Kipling, E. E. 182 Broadway, N. Y.	40	<b>Musical Boxes.</b>		Henry, Peter, Cincinnati, O.	27
Kipling, R. A., Hays Bldg., N. Y.	10	Jacot & Son, 39 Union Square, N. Y.	35	<b>Watch Importers.</b>	
Lorsch, Albert & Co., 37 Maiden Lane, N. Y.	40	<b>Optical Goods.</b>		Hyde's, J. E., Sons, 22 Maiden Lane, N. Y.	9
Smith, Alfred H. & Co., 182 Broadway, N. Y.	10	Geneva Optical Co., Chicago, Ills.	29	<b>Watch Keys.</b>	
Tannenbaum, L., & Co., cor. Maiden Lane and Nassau St., N. Y.	19	Queen & Co., Philadelphia, Pa.	40	Clark, A. N., Plainville, Conn.	40

## Special Notices.

Rates 75c. per insertion for notices not exceeding 3 lines (25 words); additional words 2 cents each. If answers are to be forwarded, postage stamps must be enclosed. Two insertions, 15 per cent. off; three insertions, 20 per cent. off; four insertions or more, 25 per cent. off. Payable strictly in advance. Display cards on this page will be charged at \$2.00 per inch for first insertion, subject to same discount as above for subsequent insertions.

Under the heading of **Situations Wanted** on this page advertisements will be inserted for **One Cent a Word**. This offer refers to **Situations Wanted only**. Payable strictly in advance. If answers are to be forwarded, postage must be enclosed.

## Situations Wanted.

*Notices under this heading ONLY are charged at one cent a word, payable strictly in advance. If answer are to be forwarded, postage must be enclosed.*

**BY** experienced watchmaker, salesman and engraver, competent to take charge. Address Parker, Lock Box 401, Madison, O.

**ENGRAVER** and salesman desires position at once. Middle States preferred. Salary \$16. Reference given for character and ability. Address Commerce, care JEWELERS' CIRCULAR.

**BOOKKEEPER**, absolutely reliable and competent to take charge of office, credits and collections, desires to make a change; for number of years in similar position in watch and diamond line; excellent references. Address Amiable, 170, Care JEWELERS' CIRCULAR.

**YOUNG MAN, 19 YEARS, WOULD LIKE A POSITION WITH A JEWELRY CONCERN WHERE HE CAN ADVANCE HIMSELF. EXCELLENT REFERENCES. ADDRESS OFFICE, CARE JEWELERS' CIRCULAR.**

**A FIRST-CLASS watchmaker** would like position after January 1st. Full set of tools. References if required. Address Whitcomb, care of JEWELERS' CIRCULAR.

**WANTED**, by a man of 28 years, a position as salesman in a wholesale or retail jewelry house; 12 years experience. References. Energetic, JEWELERS' CIRCULAR.

**A FIRST-CLASS traveling salesman**, with established trade, wants line of sterling for New York or New England. A1 references. Address B. M., JEWELERS' CIRCULAR.

**A YOUNG man** as salesman. Excellent trade in New York city and vicinity, desires to change his position. Can furnish best of reference. Would also take office position. Address Salesman, JEWELERS' CIRCULAR.

**SITUATION WANTED**—By young man 24; does not drink; good appearance; A No. 1 salesman and good engraver; been connected with the jewelry trade for 14 years; capable of taking charge of store. Address "Ulster," care JEWELERS' CIRCULAR.

**SITUATION WANTED**—As traveling salesman by a hustling young man of good appearance; can talk and sell watches, jewelry, silverware or clocks; knows the business from A to Z and can sell goods if any one can. Address "Commercial," care JEWELERS' CIRCULAR.

**POLISHER**—A competent man with 15 years' experience on watch cases and jewelry seeks steady employment. Address Polisher, care JEWELERS' CIRCULAR.

**FIRST CLASS watchmaker**, 28; experience in materials, tools, also optical goods; speaks English, French and German; would like position as salesman in retail or wholesale material house. "Material," care JEWELERS' CIRCULAR.

**SITUATION** wanted by an experienced engraver, chaser, designer and letterer. Address Ed. S. Browe, Upper Montclair, N. J.

**WATCHMAKER**, first class, wants position; 25; A1 references; full set of tools; good salesman, etc. Address J. G., care JEWELERS' CIRCULAR.

**POSITION**—As watchmaker and salesman; will start at \$10 per week. Melvin Avery, Jackson, Mich.

**WANTED**—A traveling position south or west to represent a manufacturer of rings, or rings and jewelry by A 1 salesman. "Set Rings," JEWELERS' CIRCULAR.

**TRAVELING salesman** south and west; well known and posted in jewelry and silver lines; A1 references and ability, is open for engagement. "Jewelry Trade," care JEWELERS' CIRCULAR.

## Help Wanted.

**WANTED**—A TRAVELER WELL ACQUAINTED WITH NEW ENGLAND JEWELRY TRADE. ONE WHO HAS HANDLED SILVER PLATED WARE. ADDRESS M., CARE JEWELERS' CIRCULAR.

**WANTED**—Experienced traveling salesman to carry a leading and well-known line of spectacles and eyeglasses. Samples easily carried. Liberal commission. Address Optics, care JEWELERS' CIRCULAR.

**WANTED**—A good engraver and jeweler to go south; permanent employment to right man. Address H. S., Box 32, Lynchburg, Va.

**WANTED**—A bright young man to make himself useful in wholesale jewelry and material business; must have A No. 1 references. Address, stating references, etc., T. B., care JEWELERS' CIRCULAR.

**SALESMAN**—Energetic, traveling, who visits retail jewelry trade, to carry a side line; commission liberal; samples weigh two pounds. F. M. Sproehne & Co., 108 State St., Chicago.

## For Sale.

**FOR SALE**—Well established jewelry and optical business in best business city of the south; population 30,000; only three other stores; established over five years and has been well advertised; best located store in city, nice size and moderate rent; have carried stock of \$6,000 to \$7,000; inventories now about \$4,000; could be reduced to suit purchaser; fixtures, etc., about \$1,200; sales have run from \$8,000 to \$10,000 and profits \$3,300 to \$3,800 per annum; stock consists of American watches, diamonds and a general line of jewelry, which is all in good shape and desirable goods; have made specialty of optical business and this alone pays \$1,800 per annum; would like to correspond with parties having cash, or who could give good paper and to whom I will show my books, etc., to verify my statements; only reason for selling is, am compelled to engage in out-door business on account of my failing health. Address E. A. Williams, 1005 Main St., Lynchburg, Va.

**FOR SALE**, at a bargain, jewelry store, established 18 years, 10,000 population. Easy terms. Write at once. Lock Box 133, West Gardner, Mass.

**FOR SALE** cheap, for cash, or exchange for improved real estate, a fine jewelry store, established 20 years, in a southern New England city, convenient to seaside hotels, whose patrons bring a good summer trade. The owner has other business and resides out of town. The store is run by a manager. Address C. A. B., care JEWELERS' CIRCULAR, 189 Broadway New York.

**FOR SALE**—Lapidist's grinding lathe imported 1894, of improved pattern and has never been used. Address L. Y. M., care JEWELERS' CIRCULAR.

**FOR SALE**—Stock and fixtures of an established jeweler in Catskill, N. Y.; good repair trade; stock will be sold cheap. Address Bach, 279 Main St., Catskill, N. Y.

**FOR SALE**—Jewelry store; established 10 years; with or without stock; a bargain; selling to go into another business. Henry Wolf, 164 Springfield Ave., Newark, N. J.

**FOR SALE**—Hydraulic press made by John Robertson & Son, Brooklyn, N. Y., in perfect order. Address J. B. & S. M. Knowles Co., Providence, R. I.

## To Let.

**TO LET**—52 Maiden Lane, store and basement; also two upper floors. Apply Louis Herzog, on the premises.

## For Exchange.

**UPRIGHT PIANO**, standard make, for sale; will take watch or diamonds in part payment; balance cash or time. For particulars, address G. G., 1313 Bushwick Ave., Brooklyn, N. Y.

## Miscellaneous.

**WOULD** like to negotiate in person with a reliable sterling silver manufacturing house, or a jobber in silver and kindred goods, with a view to becoming their agent, and making my store a depot for their goods. Mine is the handsomest jewelry store in Newark, N. J., located in a fire and burglar proof building; could devote a large and elegant wall case, and 20 feet of show case for display of goods; I deal principally with the better class of people; leading wholesale jewelers as references. Address Business, care JEWELERS' CIRCULAR.

**THE Omaha Optical, Watchmaking and Engraving Institute**, offers greater inducements than any other trade school in this country; our instructors are experienced in school work; we advance students rapidly in theory and practice; write for prospectus. 509 Sheely Block, Omaha, Neb.

**WANTED**—A steel lined fire proof safe; give inside and out measurement with maker's name and full description. Address K. M., JEWELERS' CIRCULAR.

**WANTED** a line of jewelry, gold or silver novelties or staple goods to handle on commission or otherwise in connection with diamond stock in Chicago and surrounding country; am thoroughly acquainted with the trade and have my own office; references. Address Elmer A. Rich (formerly Chicago manager for Alfred H. Smith & Co.), 34 and 36 Washington St., Chicago, Ill.

**WANTED**—By A No. 1 salesman, a line of silver novelties or gold jewelry on small salary with part commission; five years' experience as traveler for a large house; also acquainted with all dry goods and syndicate buyers in the east. Address M. C., care JEWELERS' CIRCULAR.

**WANTED**—A pair of flat second hand power rolls. Meyer Jewelry Co., 1018 Main St., Kansas City, Mo.

**A GOLD solder** that has a 14 kt. color, will not tarnish with perspiration, and will flow on silver. Send 25 cents for sample of (the best of all gold solder), 50 cents per dwt. Address J. J. Kerr, Manufacturing Jeweler, Indiana, Pa.

**WANTED**—Chronometer, second hand, in good condition, cheap. E. C. Kern, Montclair, N. J.

## Business Opportunities.

**I WISH** to represent a manufacturing jeweler or jobber in my New York office. Finest location; excellent references. Address Maiden Lane, care JEWELERS' CIRCULAR.

**PARTNER WANTED**—For a favorably and well-known manufacturing jeweler, with a first-class trade and good line of staple gold goods; one to act as salesman and to furnish \$6,000 to \$8,000; said amount wanted to increase the business. For particulars address C. S. Carter, P. O. Box 1223, Providence, R. I.

**A PARTY** with capital about to start a factory of silver plated hollowware wishes to find partner (with capital preferred) who is familiar with the selling of same, or a good, reliable, established house to take the selling agency for the entire output; only parties with exceptional references need apply. Address Confidential, giving full particulars, JEWELERS' CIRCULAR.

**GENTLEMAN**, with some capital, employed in wholesale business, desires partnership with a fair retailer in New York city. Address M. L., care JEWELERS' CIRCULAR.

**A BUSINESS man** or engraver having about \$5,000 to invest may secure a partnership in a successful established engraving and light manufacturing business controlling a monopoly; thorough investigation allowed; highest references asked and given. "Manufacturer A. Z.," care JEWELERS' CIRCULAR.

## WHEEL CUTTING.

We make a specialty of Wheel Cutting, Demagnetizing and Watch Repairing for the trade. Complete plant. Send for price list.

**THE WINSLOW & PENNEY CO.**  
608 Masonic Temple, CHICAGO.

THE WESTERN SUPPLEMENT OF THE JEWELERS CIRCULAR

Chicago Office: Room 517, Inter-Ocean Building.

VOL. XXIX.

CHICAGO, WEDNESDAY, JAN. 23, 1895.

NO. 26.

### Chicago Notes.

#### TRADE CONDITIONS.

Clock houses usually experience a season of quiet after the holidays, but the present year is an exception. In explanation it is said that country lines are reduced to such an extent as to leave the shelves nearly empty, and good orders are being received to keep up the store display. Business exceeds expectations for the season.

Sterling silver houses say if business keeps up for the year as it has started out that they will equal 1892, business up to the 16th equaling the entire month of January, 1894.

Trade in jewelry and cognate lines shows a marked improvement over the same period a year ago.

Herman Oppenheimer, Kansas City, visited the city last week.

M. A. Mead left the latter part of the week to visit his family in Colorado.

Wilbur B. Hall, plated ware manufacturer, Meriden, Conn., stopped several days at the Palmer House.

Manager R. A. Kettle, of the American Waltham Watch Co., returned Monday from his eastern visit.

R. Gamenthaler's jewelry store and dwelling, Barnesville, Ohio, are reported to have been slightly damaged by fire Jan. 13.

C. F. Coutts, representing E. G. Webster & Son and A. F. Towle & Son Co. lines, returned to Chicago from a short trip, and left on the 17th for St. Louis.

M. F. Barger, formerly of Woodstock, Barger & Hoefer, Kansas City, has concluded a lease for quarters on the fourth floor of the Columbus Memorial building, and will shortly open with jewelry lines.

W. F. Adams, traveler for Simpson, Hall, Miller & Co., just returned from St. Louis, reports good trade in that territory, a feeling of encouragement everywhere and that things are in much better shape than last year.

A special meeting of the American Horological Society was held at the salesrooms of J. H. Purdy & Co., sixth floor, Champlain

building Sunday, and suitable action was taken on the recent death of Aaron L. Dennison, an honorary member of the society.

The co-partnership existing between Clayton B. Shourds and Joseph Kasper, as Shourds & Kasper, southwest corner Randolph and State Sts., has been dissolved by limitation and mutual consent, Mr. Kasper retiring. The business will be continued at the same place by Clayton B. Shourds.

H. D. Cretcher, formerly for five years salesman for the Hartford Silver Plate Co., and later for a year with the Rockford Silver Plate Co., will represent the Holmes & Edwards Silver Co. and the Manhattan Silver Plate Co., on the road in Michigan and Wisconsin. Mr. Cretcher is making arrangements to leave for his territory.

The quarterly inspection of watches on Chicago, Rock Island and Pacific Railway, as compiled by J. W. Forsinger, general inspector, resulted: Total examined, 1,129; compared with standard time, weekly, 1,014; average days run, since setting, for rated watches, 30; average daily variation in seconds for rated watches, .6; rejected as unsafe, 2.

Walter L. Nason informs his friends that he will this season represent, direct from the factories, the Holmes & Edwards Silver Co. and the Manhattan Silver Plate Co., and will leave the present week for the west. This is getting back to his first love, the first named company being the one which several years ago first engaged his services.

Over 1,500 invitations have been issued for the marriage of Bessie Wade, the only daughter of Mr. and Mrs. Benj. Allen, 1815 Michigan Ave., to Phelps Hoyt. The ceremony is to be celebrated at 8 o'clock Wednesday evening, Jan. 23, at Grace Episcopal Church, and a reception to 300 guests will follow, at the home of the bride's parents.

J. B. Kendrick, auditor for Simpson, Hall, Miller & Co., visited the Chicago house the past week. Monday, Jan. 14, the factory

started up on eight hours a day and they feel they are justified in expecting a satisfactory business. There is a settled belief that things are improving nicely, and the factory will be prepared for a good trade.

Wm. J. Barber has taken the Philadelphia agency for Simpson, Hall, Miller & Co., and has located headquarters in the Penn Mutual building, 925 Chestnut St., suite 501, where he will serve the interests of the company in that city. Mr. Barber will have the assistance of his son, Fred. Barber, and R. M. Mansfield, formerly with the company at Wallingford, will look after the books. Wm. J. Barber has been with Simpson, Hall, Miller & Co. as traveler for the past 20 years.

J. W. Davidson, formerly manager for H. Muhr's Sons' Chicago office, returned from the east Wednesday, and it would seem his lot was cast in easy lines. As manufacturer's agent he will handle the productions of S. W. Bassett & Co., jewelry, Providence; F. & F. Felger, diamond mountings, Newark; O. J. Valentine & Co., fine jewelry, Newark; Allsopp Bros., rings, Newark, and I. Bedichimer, society marks and charms, Philadelphia. Mr. Davidson has a thorough acquaintance with the western trade.

K. V. R. Albertson, the well-known Australian representative of the Meriden Britannia Co., who died at Melbourne on the 6th inst., from the effects of an operation for cancer of the tongue, was at one time with N. Matson & Co., of this city, later a traveling salesman in the west for Simpson, Hall, Miller & Co., with whom he remained for several years, afterward taking the agency of the company in Australia. Twelve years ago he entered the employ of the Meriden Britannia Co., as Australian agent, New Zealand also being included in his territory. Through his long connection with the silver interests Mr. Albertson made hosts of friends in the trade. He was a man of commanding presence and pleasing personality. The father and mother of the deceased reside in Maywood, a suburb of this city, and the remains will be brought here for interment.



# BENJ. ALLEN & Co.,

141 & 143 STATE STREET, CHICAGO, ILL.

IMPORTERS AND WHOLESALE DEALERS IN

Watch Materials, Tools and Jewelers' Supplies, Watches, Clocks, Diamonds and Jewelry.

Best Attention Given to Orders. Best Goods.

\* \* \* \* \* LOWEST PRICES.



## GENEVA OPTICAL Co., CHICAGO.

CATALOGUES.

- PART 1—General Catalogue of Optical Goods.
- " 2—Microscopes and Accessories.
- " 3—Photographic Cameras, Stocks and Supplies.
- " 4—Thermometers, Barometers and Meteorological Instruments.

**PRESCRIPTION WORK** Made with Promptness and Accuracy.

**OCULISTS' or OPTICIANS' OUTFITS.** Trial Cases. Ophthalmoscopes. Lens Measures.

CORRESPONDENCE SOLICITED.

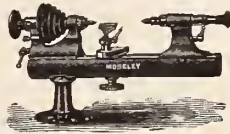

One of the best of the very best.

QUALITY IS THE STANDARD OF VALUE FOR WHICH WE COMPETE

"THE MOSELEY."

"A Bread Winner" for the watchmaker We furnish you good lathes and chucks, while the other fellow furnishes the wind. MOSELEY & CO., Elgin, Ill.



No. 2 Moseley Wire Chuck has length, strength, accuracy.



MORE ADVANTAGES—LESS COST.

## CHICAGO ROCKFORD Watchmakers' Institute

211-20 WALNUT ST., ROCKFORD, ILL.

Write for New Terms : G. D. PARSONS, Principal

**PARSONS : SCHOOL FOR WATCHMAKERS, PEORIA, ILL.**

Send for Circular and Terms. PARSONS & CO.

**G.A. WEBSTER**  
42 & 44 Madison St., Chicago, Ill.  
**Manufacturer,**  
AND WESTERN AGENT FOR  
E. G. WEBSTER & SON, of Brooklyn, N. Y.  
A. F. TOWLE & SON CO., of Greenfield, Mass.

# BOYLE, DAVIS & GOODMAN,

SPECIAL AUCTIONEERS for the Legitimate Trade only.

83 Fifth Avenue NEW YORK.

611 Pennsylvania Ave., WASHINGTON, D. C.



S. A. BOYLE.



W. M. DAVIS.



CHAS. P. GOODMAN.

**WE PAY ALL OUR OWN EXPENSES. GUARANTEE TO MAKE YOUR SALE WITHOUT LOSS.**

SEND FOR OUR BUSINESS PAMPHLET.

CONSULT US BEFORE PLACING YOUR SALE. ADDRESS ALL CORRESPONDENCE TO OUR WASHINGTON OFFICE.

### Speakers and Toasts at the 18th Chicago Jewelers' Association Banquet.

CHICAGO, Ill., Jan. 19.—Details of the annual banquet of the Chicago Jewelers' Association have been completed, and all is now in readiness for the pleasurable occasion. J. P. Byrne, secretary and treasurer of Lyon & Healy, and also secretary of the banquet committee, will be toastmaster, and the following gentlemen will speak on the respective subjects of which they are past masters:

Lyman J. Gage, president of the First National Bank, will enlighten the banqueters on the currency question; Hon. Thomas Cratty speaks of the college man in business; Hon. John Barton Payne, Judge of the Superior Court, on growth of ethics in business; Rabbi Emil G. Hirsch, now professor at the University of Chicago, on the wave of reform that is sweeping the large cities; and Dr. W. M. Lawrence, pastor of the Second Baptist Church, will speak of the new woman—she who is entering man's sphere. The National government, State and city, will be honored guests in the persons of Washington Hesing, postmaster of Chicago; General Wheeler, representing the Governor of Illinois; and Mayor Hopkins, of Chicago.

### Columbus.

Mrs. H. A. Nunemacher has been called to mourn the loss of her father, George C. Barnitz.

The Dueber Watch Case Mfg. Co.'s works at Canton have resumed operations with a full force in nearly all departments, and it is expected that soon all of the departments will be in operation.

The friends of Eugene M. Blauvelt were sorry to learn of his assignment to Barton Griffith a few days ago. Mr. Blauvelt has for several years operated a jewelry store at 569 High St. He owned no real estate, and no statement of his assets and liabilities was furnished. It is understood, however, that the assets are estimated at \$12,000. Before the deed was filed chattel mortgages on the stock of goods were left at the recorder's office as follows: To King &

Eisele, \$332.13; A. Goldsmith, \$267.92; D. Schroder & Co., \$719.38; C. Oscamp, \$437.22. Eugene M. Blauvelt, \$1,513.15; Ernest Adler, \$496.76; Eva A. Blauvelt, \$1,235; a grand total of \$4,000.30.

### Indianapolis.

Jobbers are getting ready to have their travelers on the road by Feb. 1st.

Jan. 1st Gribben & Gray gave a gold watch to the person guessing nearest the number of the Waltham movement. The guesses were many and varied.

Oscar Demdinger who, until the first of the year traveled for Nichols, Pee & Co., has become connected with Baldwin, Miller & Co., to represent them in Indiana.

Chas. Williams, Terra Haute, Ind.; Louis F. Ott, Veedersburg, Ind.; and J. Sherry Jones, Clayton, Ind., were buyers seen among the wholesale houses last week.

### Minneapolis and St. Paul.

The residence of A. E. Sawyer, jeweler, Faribault, Minn., was badly damaged by fire on the night of the 9th.

J. C. Marx, a recent graduate of the Parsons Horological School, Laporte, Ind., will establish himself in business in Shakopee, Minn., where his parents reside.

Out-of-town jewelers visiting the Twin Cities on business the past week were: Albert Wang, Shell Lake, Wis.; G. A. McHenry, West Superior, Wis.; J. C. Meacham, Prescott, Wis.; John Saxine, Prescott, Wis.

Dorner & Port, manufacturing jewelers, Duluth, Minn., recently dissolved partnership, Mr. Dorner continuing the business. J. R. Port passed through Minneapolis last week on his way west, prospecting for a new location to start in business again.

A man, giving his name as George Brown, 712 King St., Winnipeg, committed suicide in St. Paul, Jan. 13, by taking eight ounces of nitric acid. He was evidently on his way to Kansas City, as he had a ticket in his pocket reading "from Winnipeg to Kansas City." He wore considerable new

jewelry, and was evidently a jeweler by trade, as he carried a kit of tools. He also wore an Odd Fellows' badge and in his wallet was found \$160 in money.

### Cincinnati.

Albert Bros. will make a specialty of clocks this season.

Isa Schroder is one of the first this season to go on the road.

Albert Maas has contracted to represent A. Weiler & Co. in the southwestern territory.

J. C. Raulmyer, of Jos. Noterman & Co., has been confined to his home by illness for several weeks.

O. E. Bell & Co. are out with another snap. This time it is a gold plated watch for \$2.75 with a warrant.

E. A. Bliss, of the E. A. Bliss Co., Meriden, Conn., visited the western agents, Bloom & Phillips, last week.

Messrs. Pfeuger and Osthoff, of Jos. Noterman & Co., will go on the road as soon as their new stock is ready.

Miffler & Anderson, Temple, Tex., have changed their firm name to Anderson & Crawford, the former retiring.

The Homan Silver Plate Co. are alive to the interests of the trade and have begun some of the handsomest patterns that will be seen in the market this year.

Bloom & Phillips have on exhibition this week the magnificent \$1,000 cut glass punch bowl made by J. Hoare & Co., Corning, N. Y., for the World's Fair. It attracts the admiration of thousands who pass on 4th St. The firm are western representatives of J. Hoare & Co., and show samples of every item made by this cut glass house.

Eastern men registered at the Gibson House the past week were: J. E. Alexander, New York; L. P. Cook, New York; Geo. J. Smith, New York; Chas. F. Willimin, New York; Mr. Keane, New York; Thos. Frothingham, Providence; Frank Sawton, Providence; E. A. Bliss, Meriden, Conn.; J. B. Reynolds, Providence; A. R. Dorchester, New York; J. J. Robinson, New York; J. R. Sheriden, Chicago.

DIAMOND CUTTERS and POLISHERS looking for desirable and permanent positions should apply direct to

**FOX BROS. & CO.,**

68 and 70 West 4th Street,

CINCINNATI, OHIO.

### San Francisco.

John Hood, Santa Rosa, Cal., has been in town buying goods.

Mr. Harmon, of Jos. Fahys & Co., New York, has been in town.

Harry Nordman, of the Standard Optical Co., will leave next week for a trip northward.

Chas. Weinschenk, of Armer & Weinschenk, will hereafter represent the firm on the road.

Fred. Davis will leave the early part of February for the south, for Rothschild & Hadenfeldt.

A meeting of the creditors of E. C. Shaver, Watsonville, Cal., was held a few days ago in this city and he was granted an extension of time to meet his obligations.

P. J. Burroughs, jewelers' auctioneer, Chicago, will arrive here about the 25th, to dispose of the property by auction, of M. Wunsch & Co. They have a stock said to be worth \$75,000.

Davis Bros., widely known on this coast as the proprietors of the Golden Rule Bazaar, have dissolved partnership. Andrew Davis is to continue in the downtown store, while Eugene Davis will be proprietor of the uptown branch.

The latest venture in the jewelry line in this city is the formation of the Prudential Watch Insurance Co. The head of this enterprise is Allen Marshall, watch maker in the Thurlow block, and his brother David Marshall, of Vanderslice & Co. They intend to do all repairing for their subscribers for \$2 per year. They are now getting up elegant and commodious offices in the Thurslow block. The idea has been already described at length in THE CIRCULAR.

Frank Golden has sold out his store in Nevada City, Nev., to E. A. Zoberbier, and his Carson City, Neb., store to D. M. Ryan. It is said he is indebted to the following firms: M. Schussler & Co., \$8,000; Geo. Greenzweig & Co., \$5,000; A. Eisenberg & Co., \$3,000; Phelps & Miller, \$4,000, besides several smaller amounts. The question of his solvency was set at rest by the receipt of several checks from Golden to Armer & Weinschenk, and also to Geo. Greenzweig & Co.

### Pacific Coast Notes.

Samuel Moore, Ukiah City, Cal., is ill at the German Hospital, San Francisco.

J. D. Houck, formerly of Escandido, Cal. is now connected with M. German's new establishment, in San Diego, Cal.

C. Hadenfeldt has shipped the remainder of A. P. Hall's jewelry stock from Hanford, Cal., to San Francisco. Mr. Hall will give his exclusive attention now to his Tulare store.

By terms of the will of the late Bonifacius Haas, Oakland, Cal., the jewelry store in Haywards, including all book ac-

counts, is given to his nineteen year old son, Edward Haas.

The recent inspection of Jacob Jensen's onyx find, near Brigham, Utah, by Sprout & McBride, has resulted in the leasing of the property by the Ogden Onyx Co. Development work will begin at once.

The wholesale jobbing house in Seattle, Wash., carried on by Joseph Mayer and S. F. Myers & Co., will after Jan. 15th be conducted as the Empire Jewelry Co., incorporated, the New York house of S. F. Myers & Co. taking an interest in the company. Two men will be sent on the road.

The estate of J. A. Ingram, Oakland, Cal., who assigned, is found to be an empty shell. Ingram succeeded one Titcomb in business and it now appears that most of the stock belonged to Titcomb for whom Ingram was selling on commission. The outstanding accounts were mainly against firms who had failed or the claims were outlawed. The report of the assignee shows that in one case \$135 was offered in settlement of a \$4,000 account. The estate realized only about \$5,600.

### Kansas City.

C. A. Kiger, Wichita, Kan., was in town for a few days last week.

N. S. Larson, Los Animas, Cal., is in the city, partly for pleasure and partly for business.

At the regular monthly meeting of the Retail Jewelers' Association of Kansas City, held at the Midland Hotel, only routine business was transacted.

Mr. Hofer, of Woodstock, Hofer & Co., has just returned from an extended trip. He reports prospects very good in Kansas since the change in administration in that State.

The entire stock of A. L. Hosmer, jeweler, 725 Main St., is being sold at auction to satisfy the claim of \$5,600 which Susan P. Barrett had against it. The Stern Commission Co., this city, are the auctioneers.

The following country buyers were in town last week: J. H. Whiteside, Liberty, Mo.; W. H. Myer, Lossing, Mo.; A. Z. Mege, Norborne, Mo.; B. E. Taylor, Oswego, Kan.; Amos Plank, Hutchinson Kan.

Thomas W. Chambliss has been acquitted of the charge of stealing a pair of earrings from Albert E. Smith, jeweler, Sheidly building. Chambliss entered Mr. Smith's place of business and looked at some diamonds. After his departure a pair of ear drops valued at \$200, were missing.

Flint Bowen, who has had his office at 415 Keith & Parry building, will in the future have an office with Edwards & Sloane Jewelry Co. in the same building. Mr. Bowen will represent the Wm. L. Gilbert Clock Co., Winsted, Conn., Hayden Mfg. Co., Newark, N. J., and Link, Angell & Weiss, Newark, N. J., the coming year.

### Detroit.

L. W. Terrell recently opened a new jewelry store in Vicksburg, Mich.

G. H. Wells & Co., Flushing, Mich., have moved into more commodious quarters.

F. G. Smith & Sons have an elaborate display of Oriental goods in their show windows.

S. G. Seabright, a graduate from the Detroit Optical School, has located in Grayling, Mich.

H. G. Nagararian has taken the store at 269 Woodward Ave., and will convert it into an Oriental art emporium.

August Deimel, of Chicago, is engaged at the wholesale jewelry establishment of his brother, Eugene Deimel. He is an expert watchmaker.

Frank Roehm, of R. J. F. Roehm & Son, has been very ill for the last three weeks with malarial fever. He is said to be now on the road to recovery.

Rudolph Kern, jeweler, 171 Griswold St., last week discharged a chattel mortgage on his stock for \$556.65. On the same day he gave a bill of sale of the stock, fixtures and accounts to the Detroit Pharmacal Co.

Nathan Mann's jewelry store in Clio, Mich., was recently robbed of \$300 worth of jewelry belonging to Thomas Lean, which had been left in his care. His son, William Mann, and Arthur Williard, were arrested for the crime, and part of the goods were recovered here and in Saginaw. The trial of the two began last Friday at Flint. Young Williard alleged on the witness stand that Mann proposed the scheme and was the prime mover in the robbery of his father's store.

The following traveling salesmen passed through Detroit last week: George B. Case, Pairpoint Mfg. Co.; Mr. Merrill, Seery Mfg. Co.; W. F. Briggs, W. F. Briggs & Co.; Mr. Sallinger, Clark & Coombs Bros.; Mr. Wilkinson, T. B. Richardson & Co.; Mr. Kehl, F. H. Noble & Co.; Mr. Battey, Waite, Mathewson & Co.; Mr. Kettle, S. Albro & Co.; F. A. Fairbrother, B. K. Smith & Co.; Mr. Fanning, J. H. Fanning & Co.; C. M. Dillion, Meriden Cutlery Co.; H. L. Sherman, Simpson, Hall, Miller & Co.; J. E. Alexander, for Frank W. Smith; Mr. Greenwald, for H. Hehenstein; E. T. Hopkins, Meriden Silver Plate Co.; D. H. Lowman, Lissauer & Co.; J. H. Granbery, Reeves & Sillocks; A. O. Waterman, Pairpoint Mfg. Co.; Harry Osborne, Whiting Mfg. Co.; A. H. Atwood, Towle Mfg. Co.; representative of Williams & Payton; Fred. Foster, Unger Bros.

A bunco man worked W. C. Pfaeffle, jeweler, Fort Worth, Tex., recently out of a \$150 gold watch. The man went in on a boarding house and asked Mr. Pfaeffle to wait at the door while he went in to get the money. While the jeweler waited the sharper made his escape with the watch.

## The "Star Stone" Dealers of Ceylon.

FAMILIAR to some of the ancient writers, and credited with supernatural powers, the Asteria, or star gem, was highly valued for the benefits supposed to



STAR STONE DEALER ("MOORMAN") IN CEYLON AND A NATIVE LAPIDARY.

be something more than an ordinary crystal, and to the superstitious mind it could readily be believed to embody some tutelary spirit. The particular virtue attributed to this gem was the conferring upon the wearer "Health and good fortune," when worn as an amulet, and to those fortunate to be born in the month of April, with which that stone was associated or represented, the wearer was insured from all evil.

The star stone is found principally in Ceylon, invariably in soil peculiar to rubies and sapphires; indeed, it is composed of the same constituent, corundum, its chatouyant, or star-rays, being caused by the presence of what the natives call "silk." It is found in many different colors, from pale blue, pink and white to deep, dark blue, ruby and purple. The blue are termed "sapphire stars," the red "ruby stars." It is always cut "en cabuchon," the star dividing into six rays at the apex. It is next in hardness to the diamond. Of late years, since the magnificent collection in the Ceylon Court of the Colonial Exhibition, this gem has been better known, and fine specimens collected for costly ornaments.

be conferred on the wearer, says the London *Graphic*. Its bright six-rayed star, ever changing and shifting with every play of light, and especially shooting out its flames in the direct sunlight, would seem

depicted one of the "moorman" dealers in stars and other stones, well known to visitors to Colombo or Galle, who will, doubtless, remember the dusky merchant's cry of "Master, buy a fine ye starrystone."

Our artist, Major-General H. G. Robley, has

and many painfully receive a proof of the virtue of the stone in bringing good fortune to the owner when they find out they have given good sovereigns for a worthless specimen. These dealers are most persistent; no refusal will deter them from ceaseless entreaty to buy, and with cool Oriental impertunity they will persevere for days and weeks.

The "moorman" here stands by his native lapidary, who, with tools as rude and simple as his forefathers used 1,000 years before, with no training or instruction, ex-



STAR STONES UNDER CONCENTRATED LIGHT, AT THE ASHMOLEAN MUSEUM, OXFORD.

cept the unwritten mysteries of the craft handed down from father to son, will produce the most wonderful results in cutting and polishing gems, and in many instances rival the more educated lapidary of Europe for judgment in cutting gems to the greatest advantage.

### Birmingham, Ala.

The firm of Gluck & Black composed of E. Gluck and William Black which has been in the jewelry business here for about ten years was Jan. 18, dissolved by mutual consent. Mr. Gluck will continue business at the old stand corner of 21st St. and First Ave., assuming all the liabilities and assets of the late firm, while Mr. Black has gone to Montgomery to engage in business on his own account. Mr. Black has purchased the jewelry business of Otto Stroelker on Dixon Ave., in Montgomery and assumed charge Jan. 19.

Charley Jones who for many years has been a jeweler at Greensboro, has retired from the jewelry business and will pursue a scientific course.

Secretary William Rosenstihl, of the Alabama Retail Jewelers' Association, is now engaged in taking a ballot by mail on the place for holding the next annual meeting of the Association. This meeting will convene during March and is expected to be the most important ever held in the State. A number of lectures by distinguished jewelry manufacturers from abroad will be delivered; matters bearing upon some important legislation will also come up, besides the election of officers. The Association is growing all the time and is now quite strong.

**TOWLE**  
MANUFACTURING  
COMPANY.  
MANUFACTURERS.

OLD ENGLISH STRAWBERRY FORK.

STERLING SILVER  
TABLE WARE,  
IN A COMPLETE ASSORTMENT.

149-151 STATE STREET  
CHICAGO ILL.

Newburyport, Mass.

**WM. SMITH & CO.,**  
Manufacturers of Gold, Silver and Roll Plate Chains and Jewelry.



Novelties in Gold and Silver Bead Necklaces and Bracelets. Also a large line of Chain Trimmings and Silver Rings.

Office: 5 and 7 Maiden Lane, New York.      Factory: 61 Peck Street, Providence, R. I.

## New Escapements and Difficulty of Introducing Them.

THE CIRCULAR has, at different times, expressed its opinion about, and criticised new escapements. It is well, however, that the thinking watchmaker should employ some of his spare moments in devising them, because it prevents him from becoming a mere machine working by rote, and although he may fall short of his aim to produce something that shall be better than the mechanisms heretofore existing, the horological science is all the better for the fact that he has lived and thought, as his successors in the world of invention will avoid the mistakes he committed. The following is the closing of an article written by one of the foremost watchmakers of Germany, F. W. Ruffert, who publishes his experiments under the above caption in the *Deutsche Uhrmacher Zeitung*:

"In order," he says, "to better illustrate the preceding remarks, I will finally give my own experience with escapements. I have, since the commencement of my vocation as watchmaker—that is 45 years ago—occupied myself with the invention and improvements of escapements; they have become known partly, and partly they have not. Of all my inventions I considered only one to be practical, to wit, the free pendulum escapement, with constant power, which will be known to readers of this journal.\* This escapement really discharged the functions for which it was gotten up, to wit: it preserved equally large arcs of oscillation, even with double the force of the mainspring.

"The escapement is a dead beat—that is, the impulse is imparted only at every second beat of the pendulum, whereby the escape wheel moves forward one whole tooth. In clocks with seconds pendulum and an escape wheel of 30 teeth, the seconds hand moves consequently forward two entire teeth at every second beat only. In those oscillating half-seconds, however, the hand would move forward one second at every second beat of the pendulum. I then tried to improve this escapement by giving it another shape, whereby the pendulum received an impulse at every beat; in a third shape, only after several beats; this disposition, however, I dropped soon afterward. Although the fundamental idea—that is the uniform impulse of the pendulum, with an unequal force of the train, is not new, still the shape of my escapement was. It was very favorably received by the horological press, especially as it appeared to be well adopted for clocks with long rates, since it required little impulse.

"As I was not in a sufficiently favorable situation to work the invention myself, I spared no pains to find a purchaser, and made pecuniary sacrifices, but my endeavors were void of results. I was already on

the point of taking out another patent for the altered escapement, when the happy thought occurred to me that I had perhaps better keep the money in my pocket, as the original patent was a steady source of expense. I let it drop after two years, and have never heard since that either one or the other form of the escapement has ever been used.

"How easily cases of misconception may occur in matters of this kind is shown by the circumstance that Mudge, the inventor of the original rack lever escapement, had already invented my pet escapement, although in a somewhat different shape. It is highly surprising that none of my colleagues ever found this out, but that I, myself, was called on to ascertain this fact.

"And thus it is with many other escapements. When our horological papers started, they contained many disputes about the priority of invention of escapements, although they were no longer new, but in use in a somewhat altered form. Many have at present undertaken to impart a steady impulse to the chronometer balance. A lever is for this purpose interposed between the balance and the escape wheel, which stretches the former and imparts the impulse. The following is overlooked, however:

"1. By this disposition the vibration arcs of the balance become unequally large, because the unlocking resistance differs according to the impulse force. An increased impulse has a greater unlocking resistance, and, consequently, a smaller vibration.

"2. The uniform impelling force of the balance is by this disposition an illusion only because the force effecting the tension of the impelling lever, can be imparted solely by a spring; the resisting force of springs, however, is subject to changes.

"3. The impelling force of the chronometer, even without a fusee, is almost entirely uniform.

"4. With the present chronometer escapement the unlocking resistance increases with the augmenting impulse force, although this creates no complete equalization, at any rate, a partial one.

"The ordinary chronometer escapement is simple and reliable; all its complicated modifications have defects that are not counterbalanced by the advantages of the pretended steady impulse.

"The inventor of a new escapement must first ask himself: How are the proportions as regards the degrees of lifting? How does the escapement behave, when the hands are moved forward or back? How does it act in winding or by irregular motions, when transported? How can it be set in order again, if for some reason or other it has become disarranged how can the drop be regulated? etc. He should either answer these questions himself without prejudice, or, what is better, have them answered by another person, and he will find that a small defect is invariably present. The simple forms are always the best, and

many of those novelties which are considered to be new inventions, existed already at a previous time. A new conception should always be constructed in metal, because in the making, only the inventor will encounter defects that can either be overcome with great difficulty only or not at all.

"A long period elapses until a good thing is recognized. Not only prejudice, but also well founded considerations, are frequently to be overcome until an actual improvement is valued and adopted universally. Other factors must often be taken into account. Take, for instance, the Graham escapement, invented as early as 1720; it remained practically unknown, and has been introduced generally only for the last 20 or 30 years. If the inventor hoped to reap a pecuniary benefit from his invention he must have waited for more than 200 years.

"Next, as regards the bare 'honor,' which, it should be thought, cannot escape from the inventor, the same state of things prevails; it follows in this part of our art scarcely ever immediately after the invention. The value and magnitude of an invention is estimated now-a-days generally by the pecuniary results accruing therefrom. That many are entirely lacking in judgment, I saw visibly demonstrated with my escapement mentioned above. It was, as averred, 'improved' and 'simplified,' nevertheless it was plain that the 'improvers' and 'simplifiers' most generally did not even comprehend the first fundamental idea of it; nor were they capable of ascertaining which was really its principal merit.

"Above mentioned remarks also apply to the lever escapement for watches that appeared recently, in which the lever is divided into two parts, distributed upon two axes, and again united one with the other. This escapement is an alteration of the lever escapement; it possesses no merits, whatever, but a number of defects; it is unpracticable, and never will it have any prospect of being used.\*

"At a former time when the balance together with its spring had not yet attained to its present form, and still performed in an imperfect manner, the idea was frequently entertained that two balances should really regulate better than one. The escapements were, therefore, divided in different ways, so as to use two balances, and the lever was frequently doubled and again united. There is an entire series of them, and the above mentioned lever escapement undoubtedly owes its existence to the similar train of thought.

"It is really a difficult matter to state what kind of escapements are worthy of being published. Although no great benefit will accrue from any one of them, we wish it, nevertheless, not said that, as regards escapement, there is no progress possible.

\*The escapement was in due time published, with proper illustrations, in THE CIRCULAR.

\*For further particulars see THE CIRCULAR, No. 25, date July 25, in which the escapement is criticised in a similar manner.

**HENRY FERA,**  
IMPORTER AND CUTTER OF  
**DIAMONDS,**  
10 MAIDEN LANE, NEW YORK.

ESTABLISHED

AS AN IMPORTER SINCE 1871.  
AS A CUTTER SINCE 1878.

I hereby take pleasure in announcing that I have just opened, in addition to my present establishment at 10 Maiden Lane, new **DIAMOND CUTTING AND POLISHING WORKS** at No. 60 FULTON STREET, fitted up with all modern improvements by The Arthur Co.

My workmen are the very best in the trade and my long reputation as an expert guarantees the finest work possible.

CUTTING FOR THE TRADE A SPECIALTY.



SPECIALTY: SALES OF  
**JEWELRY BRIC-À-BRAC**  
AND  
ARTICLES OF VERTU

The publishing of new ones is invariably interesting to the thinking watchmaker, and only by comparing them will he be able to understand the merits of this or that. Nor is it impossible that an inventor will at once reap a pecuniary benefit from his new mechanism. The writer simply penned above remarks so as to guard the inventor against loss and deceptions."

### Timing in the Positions.

**T**O adjust a watch so that it has the same rate when placed first in a horizontal and then in a vertical position is a delicate and often difficult operation; thus it is seldom found to be properly done in ordinary watches. It will be well here to summarize such of the directions as have a bearing on every-day work. The rates in a vertical and horizontal position are made identical or nearly so by equalizing the resistances that interfere with the motion of the balance in the two cases, and by taking advantage of the displacement of the center of gravity of the balance spring.

Satisfactory results will be obtained in most cases by employing the following methods, either separately, or two or more together, according to the results of experiments on the rates, the experience and the judgment of the workman.

1. Flatten slightly the ends of the balance pivots so as to increase their radii of friction; when the watch is lying flat the friction will thus become greater.

2. Let the thickness of the jewel holes be no more than is absolutely necessary. It is sometimes thought sufficient to chamfer the jewel hole so as to reduce the surface on which friction occurs; but this does not quite meet the case since an appreciable volume of oil is maintained against the pivot.

3. Reduce the diameters of the pivots, of course changing the jewel holes. The resistance due to friction, when the watch

is vertical, increases rapidly with any increase in the diameters of pivots.

4. Let the balance spring be accurately centered, or it must usually be so placed that the lateral pull tends to lift the balance when the watch is hanging vertical. In this and the next succeeding case, it would sometimes be advantageous to be able to change the point at which it is fixed; but this is seldom possible.

5. Replace the balance spring by one that is larger or shorter, but of the same strength: this is with a view to increase or diminish the lateral pressure, in accordance with the explanation given in the last paragraph.

6. Set the escapement so that the strongest impulse corresponds with the greatest resistance of the balance.

7. Replace the balance. A balance that is much too heavy renders the timing for position impossible.

8. Lastly, when these methods are inapplicable or insufficient, there only remains the very common practice of setting the balance "out of poise."

If there is any gain in the vertical hanging position of the watch slightly reduce the lower side of the balance; the vibration will increase somewhat in extent, and there will be a losing rate in this position. The opposite course must be adopted in the opposite case.

When the vibration exceeds a whole turn, the changes will be the reverse of those above indicated. This fact must not be forgotten, especially in regard to the duplex and lever escapements, which may at first make a vibration of more than a turn, and subsequently less, according to the state of the oil.

We would again observe that the timing of a watch for position presents some difficulty and it will be only after making a number of trials and studying the mechanism that the watchmaker will be able to accomplish it with certainty.

Frank F. Fulcher, Marion, Ind., has given a chattel mortgage for \$236.

# R., L. & M. Friedlander,



We have made great reductions in the prices of Watch Glasses.

SEND FOR PARTICULARS.

Are now located on  
ground floor of

## 30 Maiden Lane, N. Y.

IMPORTERS OF  
**DIAMONDS.**

WHOLESALE  
**JEWELERS.**

JOBBERS IN  
**American Watches.**

SEND FOR OUR NEW CATALOGUE.



# L. STRAUS & SONS,



IMPORTERS AND MANUFACTURERS,

China, Pottery and Glassware, 42, 44, 46 & 48 Warren St. and 116 Chambers St., N. Y.  
PARIS, CARLSBAD, RUDOLSTADT, LIMOGES, STEINSCHONAU.



## THE LATEST NOVELTY IN BIBLE BOOK-MARKS.

MOUNTED WITH

Sterling Silver or Gold Ornaments,

ON ALL SILK RIBBONS, 3 1-2 INCHES LONG  
WITH APPROPRIATE QUOTATIONS

**WOVEN IN THE SILK.**

Nine different quotations. Ribbons in the following colors: Purple, black, white and lilac. Can be sold profitably at a popular price. Made only by

**STONE BROTHERS,**  
535 Broadway, NEW YORK.

When you buy

Cut Glass

You want the best!

That which bears our  
Trade Mark

Has no superior

And will prove profitable and satisfactory.

**T. B. CLARK & CO., Inc.,**  
860 Broadway, N. Y.,

Factories, HONESDALE, PA.

N. E. Cor. 17th St. & Broadway.



Philadelphia College of Horology

Is not the largest but is the finest school in the country. A practical school to learn watch-making, engraving, and jewelry repairing. One tuition pays for all branches. Send for prospectus.

**F. W. SCHULER, PRINCIPAL.**  
1213 Filbert St., Philadelphia, Pa.  
Write for particulars of our corresponding course.



## AMERICAN WATCH TOOL CO.

ESTABLISHED 1872.  
INCORPORATED 1894.



THE  
**Webster-Whitcomb**

1-4 Size

GROWS IN POPULARITY.

PRICES AS LOW AS CONSISTENT WITH QUALITY.

Ask your Jobber for Price List of 1895, or write to us at  
**Stoney-Batter Works, Chymistry Dist., Waltham, Mass.**

**SAFES FOR JEWELERS.**

**MOSLER, BAHMANN & CO.,** 518 BROADWAY  
NEW YORK.  
Patent Fire and Burglar Proof Safes.

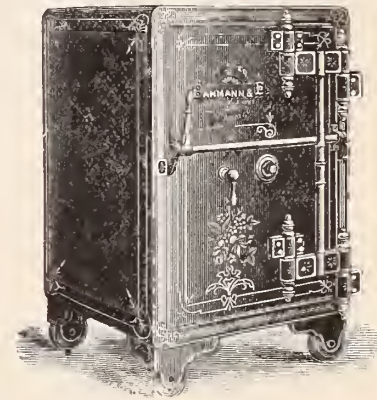

Large Assortment Always on Hand.  
Send for our Representative.  
Special Safes to Order.  
Jewelers' Safes a Specialty.

IMPORTERS OF  
**DIAMONDS,**  
WATCHES, JEWELRY, CHAINS,  
NOVELTIES, ETC.  
Latest Designs. Lowest Prices.

**AIKIN-LAMBERT  
JEWELRY CO.,**  
19 Maiden Lane, New York.  
CHICAGO BRANCH '03 STATE ST.



# FERDINAND BING & Co.,

106 GRAND ST., N. Y.

NEW DESIGNS IN \_\_\_\_\_

China Clocks and Gilt Bronze Sets, Fine Painted

Dresden Goods in Vases, Cups and Saucers, and Plates;

Cararra Marble Statuary, French Cabinets and other

Fancy Furniture.

## Paul : Jeanne's : Revolving : Hairpin.

THE LATEST NOVELTY.

220 Fourth Ave., cor. 18th St.,

NEW YORK.

WOOD & HUGHES,  
STERLING SILVERWARE MANUFACTURERS

New York Agents for the Derby Silver Co.

FINE QUADRUPLE PLATED WARE,  
No. 16 JOHN STREET, NEW YORK  
206 Kearney St., San Francisco, Cal.  
HASKELL & MUEGGE, Agents.

THE LINE OF THE NOW WELL KNOWN

## L. E. & Co. SPRING BACK STUDS



WILL BE UNSURPASSED FOR  
PRICE, VARIETY, STYLE AND WORKMANSHIP.

..... WE MAKE .....

LINK BUTTONS in popular patterns at right prices.

GENTLEMEN'S RINGS with all the correct Stones,  
Jades, Jaspers, Cornelians, Garnets,  
Etc. SIGNET RINGS.

LADIES' RINGS in the greatest variety of combinations.

CHILDREN'S RINGS in all styles.

STONE SEALS. A full line in Jades, Jaspers and  
Sards.

THE INTRODUCTION OF  
NEW MANAGEMENT  
AND METHODS IN OUR  
FACTORY WILL ENABLE  
US TO MAINTAIN OUR  
REPUTATION FOR EXCEL-  
LENCY OF PRODUCTION,  
AND AT THE SAME TIME  
PLACE OUR GOODS BEFORE  
THE TRADE AT PRICES  
THAT WILL COMMAND  
ATTENTION

## LARTER, ELCOX & Co.,

21 & 23 MAIDEN LANE, NEW YORK.

Factory, Cor. Mulberry and Chestnut Sts., Newark, N. J.



OUR TRADE MARK.





THE TRADE MARKS ON PORCELAIN AND POTTERY.

PART III.—MARKS ON GERMAN AND AUSTRIAN WARES.

IN taking up the marks on the German and Austrian wares it may prove the best plan to begin with the proprietary trademarks, those used on wares carried by the several firms. As these number in the hundreds only those marks of the principal dealers, whose wares are carried more or less extensively, by the jewelry trade, are here given.



RUDOLSTADT.  
L. STRAUS & SONS.

Of the three marks illustrated above the first two are of the Rudolstadt trademarks, found on the pottery of the New York & Rudolstadt Pottery Co., whose product is controlled by L. Straus & Sons, 42-48 Warren St., New York. The third is the trademark of L. Straus & Sons' Carlsbad ware.

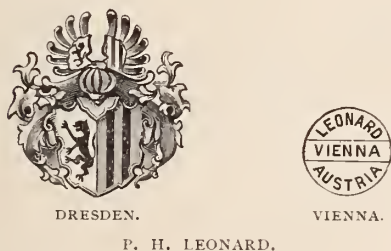

DRESDEN.  
P. H. LEONARD.

The smaller trademark above is to be found on the Vienna china of P. H. Leonard, 78 Reade St., New York. The larger mark appears on a line of rich Dresden novelties introduced last year.

The following trademarks are found only on the goods handled by Chas. Ahrenfeldt &

Son, 50-54 Murray St., New York. The first is the trademark on their Saxonia ware, the second that on their Carlsbad



CARLSBAD.



SAXONIA.



IMPERIAL AUSTRIAN.

CHAS. AHRENFELDT & SON.

china, and the third the mark on their Imperial Austrian ware. A new trademark will soon appear on this firm's Carlsbad lines.

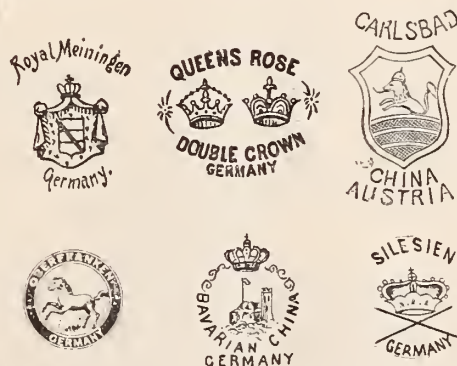

MARKS ON BAWO & DOTTER'S AUSTRIAN AND GERMAN WARES.

The above trademarks are borne by six lines of china of Bawo & Dotter, 30-32

Barclay St., New York. The name by which these wares are known will be found included with the marks.



CARLSBAD.  
HINRICHS & CO.

The Carlsbad goods of Hinrichs & Co., 31 Park Place, New York, will be identified by the above mark.



VICTORIA.

LAZARUS, ROSENFELD & LEHMANN.

Lazarus, Rosenfeld & Lehmann's Carlsbad line is known as Victoria ware and is stamped with the above trademark. This ware is sold only by Lazarus, Rosenfeld & Lehmann, 60-62 Murray St., New York.



A. K. CARLSBAD  
C. L. DWENGER.

The A. K. Carlsbad china, on which this mark appears, is controlled by C. L. Dwenger, 35 Park Place, New York.

The following trademarks are those of other prominent German and Austrian wares handled by jewelers, which are for sale in the general market. They include: Royal Dresden, plain or R. K. Dresden, Royal Berlin, Royal Bonn, Royal Copenhagen, Magdebourg, Fisher's Hungarian (commonly known as "Five Churches"), Teplitz, Plaue, Pirkenhammer, and Elbogen or Austrian faience.

**The Connoisseur.**

(Continued from page 37).

Nearly all of these wares are contained in the warerooms of the large importing houses

Geo. Borgfeldt & Co., 18-22 Washington Place; Ferd. Bing & Co., 106 Grand St.; L. J. Glaenger & Co., 80 Chambers St.; Bawo & Dotter, 30-32 Barclay St.; Hinrichs & Co., 31 Park Place; L. Straus & Sons, 42-48 Warren



**Bonn**

BOON.



ROYAL BERLIN.



K P M

ROYAL DRESDEN



Dresden  
GERMANY

DRESDEN.



MAGDEBOURG.



ROYAL COPENHAGEN.

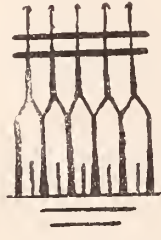

FIVE CHURCHES.



NANCY FAIENCE.



PLAU

PLAUE.



PIRKENHAMMER.



AUSTRIA

ELBOGEN.



TEPLITZ.

of New York, among the principal being: Chas. Ahrenfeldt & Son, 50-54 Murray St.;

St.; Lazarus, Rosenfeld & Lehmann, 60 Murray St.; Leboutillier & Co., 86o B'way.

**CODDING BROS. & HEILBORN,**

North Attleboro, Mass.

Makers  
OF

**QUICK SELLING NOVELTIES**

In Sterling Silver.

NEW YORK OFFICE—C. A. Vanderbilt, 178 Broadway.

CHICAGO OFFICE—F. A. Buck, 103 State Street.

365 DAYS AHEAD OF THEM ALL.

Apply at Once for Catalogue and

**BEATING BICYCLES**

AGENCY FOR

FACTORY, HOLYOKE, MASS.

SEE THAT CURVE

Jewelers make good agents and get more profit on one bicycle than on six average watch sales.

**The Other Side of Life.**

"I guess I'll take them," mused the burglar, softly slipping the silver spoons in his pocket. "I'm no darned gold-bug."—*Chicago Tribune.*

JEWELER—This cup costs two dollars extra on account of the chasing.

FARMER WAYCROSS—Yer don't hafter chase me. I pay cash.—*San Francisco Chronicle.*

"You brought all that beautiful china back with you?" exclaimed the caller: "didn't you break anything?"

"Nothing but the custom laws," replied the young lady, who had just returned from Europe.—*Washington Star.*

"Your new servant girl is very pious, I hear?"

"Yes; if she was as careful about the crockery as she is about the ten commandments she would be a jewel."—*New York Press.*

WHAT SHE WOULD NEED NEXT.

SHE—These glasses are not strong enough for me. What comes next to number two?

HE—Number one.

"And after that?"

"After number one you will need a dog."

—*Life.*

ENTITLED TO THE NAME AGAIN.

"Amy has celebrated her golden wedding."

"What do you mean?"

"The man she married is worth \$2,000,000"—*Detroit Free Press.*

SUPERSTITIOUS.

KIDDY McNAB—Wot wuz it fur Swipesy got sent up?

TOMMY THE RAT—He holds a loidy up one day on Maderson Ave., an' pinches her opal pin. Dat's highway robbery, an' he's doin' time fer six.

KIDDY McNAB (with conviction)—Didn't I allus tell yer dem opals wuz unlucky?—*Puck.*

THAT YOUNG MAN.

"Did you ever pay any attention to theosophy, Mr. Slogo?" she asked, with deadly sweetness in her tones.

The young man admitted that he had not.

"Oh, it is just lovely!" she continued.

"I have often thought how perfectly charming it would be to send one's astral self down into the parlor to entertain while one's tired self was sound asleep."

The ticking of the little clock became so painfully loud that the young man was forced to look at it and suddenly discover that it was really growing so awfully late.—*Indianapolis Journal.*

# HINRICHS & CO., 29 and 31 Park Place, NEW YORK

IMPORT AND STOCK SAMPLES FOR SEASON OF 1895 READY.

## THE BOWDEN SEAMLESS RING

IS MADE ONLY BY

### J. B. BOWDEN & Co.,

Makers of Finger Rings of every Description

REMOVED FROM BROADWAY AND JOHN STREET,

## TO 3 MAIDEN LANE, NEW YORK.

### A Complete Establishment

MEANS PERFECT WORK

In every detail of

### ASSAYING, REFINING AND SMELTING.

The proof that mine is such lies in the prompt and satisfactory returns invariably given all my customers. ARE YOU ONE?

HIGHEST MARKET RATES FOR OLD GOLD AND SILVER.

### J. RATHBONE,

Nos. 1 to 9 Matthewson St., cor. Cove, Providence, R. I.

ESTABLISHED 1870.



TRADE MARK.

## SAMUEL C. JACKSON,

MANUFACTURER OF

### FINE CASES FOR

Jewelry, Silverware, &c., also Hardwood Chests, Trays, and Sample Cases.

## 180 BROADWAY,

### NEW YORK.



KETCHUM & McDOUGALL,  
MANUFACTURERS  
GOLD & SILVER THIMBLES,  
GOLD COLLAR BUTTONS,  
AUTOMATIC EYE-GLASS HOLDERS  
198 BROADWAY N. Y.



ILLUSTRATED CATALOGUE SENT ON APPLICATION

### THE AMERICAN KNIFE AND SCISSORS SHARPENER.



TWO-THIRDS SIZE.

PAT FEB 23 '92

For Table Use.

### Special Inducements to Jobbers

... Manufactured only by the

## MOSSBERG WRENCH CO.,

ATTLEBORO, MASS.

Makers of Novelties in Silver and Hardware.

### Practical and Handsome.

A Silver Plated Knife and Scissors Sharpener, retailing at a popular price. Perfect in action, nothing to wear out. Cutting discs of finest hardened steel. An ordinary sharpness or a RAZOR EDGE can be acquired in a few moments.



TWO-THIRDS SIZE.

FOR DESK USE.

- FOR SALE BY
- Benj. Allen & Co., Chicago, Ill.
  - F. M. Sprochnle & Co., "
  - G. A. Webster, "
  - L. Straus & Sons, New York.
  - E. G. Webster & Son, "
  - Oskamp, Nolting & Co., Cincinnati, O.
  - Baldwin, Miller & Co., Indianapolis, Ind.
  - Eliassof Bros. & Co., Albany, N. Y.
  - Thos. Long & Co., Boston, Mass.
  - Smith & Patterson, "
  - Dame, Stoddard & Kendall, Boston, Mass.

EMERALDS.

E. KIPLING,

182 Broadway, New York.

ELEVATOR ENTRANCE, 2 JOHN ST.

S. F. MYERS & CO.,

Manufacturing and  
WHOLESALE JEWELERS,  
1895 Issue, No. 39.

OUR ROYAL CATALOGUE

Illustrates all that is new, unique  
and desirable in

everything that pertains to jewelry.  
600 pages, size of this publication  
Free to dealers.

SEVEN DOUBLE FLOORS.  
TWENTY-TWO DEPARTMENTS.

Myers Buildings, 48-50 Maiden Lane,  
33-35 Liberty St., New York.



OUR SPECIALTY

The Largest Stock of  
CHIMING  
AND  
STRIKING  
HALL CLOCKS

ever shown.

Chas. Jacques

CLOCK CO.,  
22 Cortlandt Street,  
NEW YORK.

Diamond Polishing Machines.

We build these machines complete with latest improve-  
ments also polishing wheels, tongs, dous, weights,  
shafting, belting, ventilating fans, gear-cutting, die blanks,  
etc., We do general repair work on jeweler's machinery.

THE ARTHUR CO.,  
General Machine Works,  
86 JOHN STREET, NEW YORK.

B. & W. B. SMITH,  
220 W. 29th St., New York.

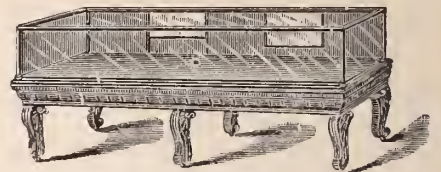

Improved Dust-Tight Counter Cases,  
Perpendicular Sliding Doors.

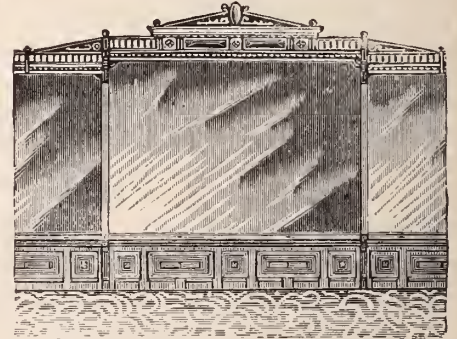

Improved Dust-Tight Wall Cases.  
Furnished with Improved Shelving and ar-  
ranged for Electric Lighting.

Sold by all whole-  
sale dealers at manu-  
facturer's price.

A. N. CLARK & SON  
PLAINVILLE  
CONN.

Manufacturer of the Celebrated  
LOOP WATCH KEY.

The Best for the Price in the World,  
CROSBY'S JEWELING TOOLS IMPROVED.

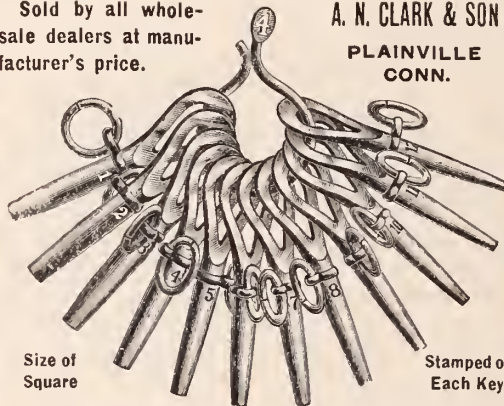

Size of  
Square

Stamped on  
Each Key.

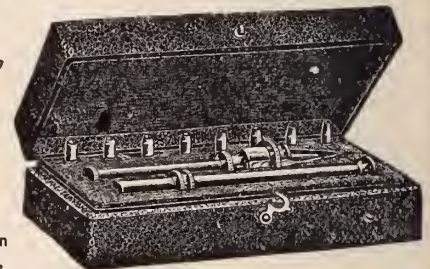

Will quote royalty or price for the manufacturing of articles of real worth.

L. LELONG & BRO.,  
GOLD AND SILVER

Refiners, Assayers AND Sweep Smelters,

SOUTHWEST CORNER HALSEY AND MARSHALL STREETS,

NEWARK, N. J.

SWEEPINGS A SPECIALTY.

PRESCRIPTION WORK.  
QUEEN & CO.,  
1010 Chestnut Street, PHILADELPHIA.  
SEND FOR PRICE-LIST AND ORDER FORMS.

U. S. SMELTING & REFINING WORKS.

Sweep Smelting and Assaying, Platinum in Plate and  
Wire. Chemically Pure Copper. Ore and Bullion  
Assays a specialty.

Highest prices paid for old gold and silver.  
Sole manufacturers of Phoenix Flux  
and Eureka Alloy.

M. WOLLSTEIN, 25 John St., New York.

ALBERT LORSCH & Co.,

37 MAIDEN LANE, NEW YORK.

Branch, 167 Weybosset Street, Providence. R. I.

IMPORTERS OF DIAMONDS,

Rose Diamonds, Rubies, Sapphires, Emeralds, Opals, Moonstones,  
Fancy and Imitation Stones, Novelties.

SOLE OWNERS AND IMPORTERS OF

The Sumatra Gem.

REG'D. UNEQUALLED IN  
BRILLIANCE AND  
HARDNESS

HIGHEST AWARD AT THE COLUMBIAN EXPOSITION, CHICAGO, 1893.

IT PAYS TO KEEP IN TOUCH WITH TRADE AFFAIRS.  
THE JEWELERS' CIRCULAR. For 4c. a Week will do it. **Subscribe.**

DIAMONDS and Cutters. L. & M. KAHN & CO., 172 BROADWAY, NEW YORK.

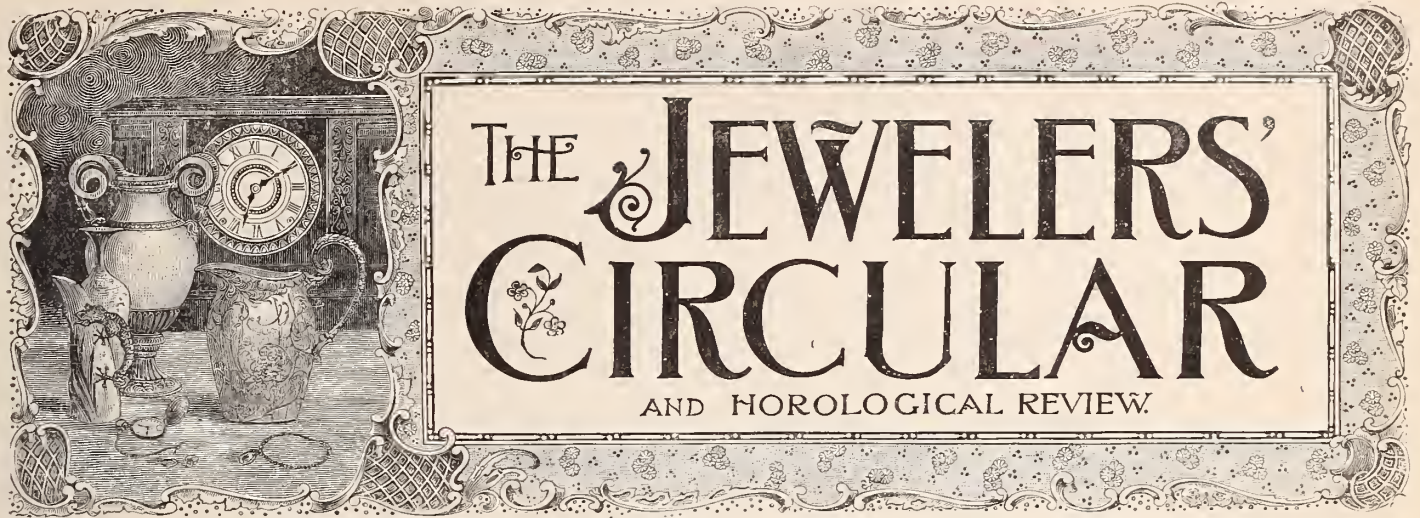

Copyright by THE JEWELERS' CIRCULAR PUB. CO.

189 Broadway, New York.

Entered at the Post Office in N. Y. as second-class matter.

VOL. XXIX.

NEW YORK, WEDNESDAY, JAN. 30, 1895.

No. 27.

THE CHICAGO JEWELRY TRADE IN PEN AND PICTURE.

EVENTS of 40 years ago are vividly recalled to mind by hundreds in the jewelry trade of to-day, and yet, at that jeweler, opened at 77 Lake St., the business street of those days, in a two-story frame building two doors east of the old Tremont now the site of the First National Bank. Mr. Speer's business was burned out in a fire that destroyed the Tremont House, but



THE "MAIDEN LANE" OF THE WEST.—EAST SIDE OF STATE ST., CHICAGO, LOOKING NORTH FROM MONROE ST.

time, 1855, Chicago was a-borning and boasted not the convenience of a jobbing jewelry house. Later in that year, however, Isaac Speer, Chicago's first wholesale House. A dull day was passed in shooting prairie chickens where now is 12th St., ducks at Bridgeport, and the younger generation poled rafts on Dearborn St. ear Monroe, he saved his stock and moved across the street, returning to his first location on the completion there of a new brick structure. He built up a business of \$100,000 to \$200,-

# C. H. KNIGHTS & CO.,

HEADQUARTERS

FOR



# Diamonds.

Imported direct from

AMSTERDAM.

Columbus  
Memorial  
Building,

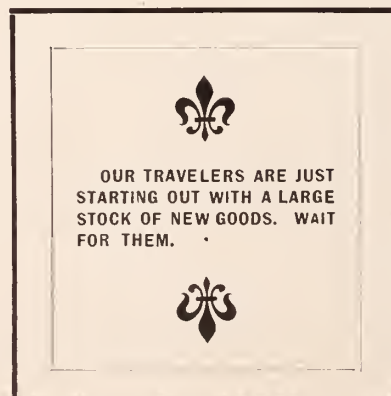

Chicago,  
U. S. A.



# FOSTER & BAILEY,



100 RICHMOND ST., PROVIDENCE, R. I.

Manufacturing Jewelers and Silversmiths.

925/1000.

HEADQUARTERS FOR MANICURE GOODS.

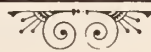

Garters

Link Buttons

Scissors

Neck Chains

Bag Tags

Glove Buttoners

Hat Marks

Chain Mountings

Pen Wipers

Shirt Waist Sets

Emery Balls

Crosses, Earrings

Match Boxes

Solid Gold Locket

Coat Hangers

Locket and Charms

Pocket Knives

Silver Belt Buckles

Pocket Combs

"Mount Hope" Buttons

Paper Cutters

Bracelets and Padlocks

Seals, Button Hooks

Pins and Neck Buckles

And Silver Novelties

Rolled Plate Watch Chains

Without End, all Sterling.

$\frac{1}{10}$  Gold Vest and Dickens Chain.

And also those

**HANDY SETS FOR TOILET IN LEATHER ROLLS.**

000 a year, but failed in the crisis of 1857 and lost \$200,000 through the panic.

Isaac Speer was followed by Oppenheimer & Metzger a few months after his opening, and in 1863 came Marcus Kronberg. C. F. Happel went to Chicago from Dixon, Ill., in that year, and opened a retail store at 23 N. Clark St., and in 1866 established a wholesale business at 124 Lake St. Mr. Happel may thus claim to be the first jeweler in Chicago among those now doing business. Subsequent to Mr. Happel's coming, jobbing houses followed in quick succession. Among these were Quimby & Co., which later became Benj. Allen & Co.; W. B. Clapp & Co., now Otto Young & Co.; B. F. Norris & Co., changed now to B. F. Norris, Alister & Co.; Giles Bros., Chas. Wendell, B. F. Ashelman, Kearney & Swartzchild, and others.

Thus at the time of the great fire in 1871 it will be seen that the jobbing trade was in its early youth. Following the fire the growth in numbers and importance was steadily augmented, until to-day this department of the trade stands forth in lusty manhood and invites comparison as being fully representative of the great distribut-

stands pre-eminent. Chicago is dependent on the east for supplies; the east is dependent on Chicago for their distribution.



ISAAC SPEER.

THE EARLIEST WHOLESALE JEWELER IN CHICAGO.

Let the retail jeweler, in fancy, accompany THE CIRCULAR representative in a visit to the trade as seen at the present day. A leading center of attraction is the Columbus Memorial building, illustrated herewith. Of beautiful architectural propor-

tions, the structure is built of steel and terra cotta, lined with marbles throughout its fourteen stories. Among buildings this is the jewelery palace of Chicago, the home of the Chicago Jewelers' Association, and within its walls is, probably, the greatest concentration of jewelry interests in any one building in the world. Taking an elevator to the 14th floor we find Tatsch & Wild displaying pearls and precious stones. A visit to the diamond cutting works of Stein & Ellbogen Co. would here be interesting, but we failed to ask for the necessary permit from the salesrooms of the company on the 4th floor and a "No Admittance" sign confronts us. Dropping to the 9th floor, we greet at his downtown office Dr. H. M. Martin, president of the Chicago Ophthalmic College, and continue to the 8th floor, where we enter upon eight floors filled solidly with jewelry and cognate houses, and solid houses,

of which organization he is the acting secretary, and also on the Waterbury Watch Co., F. H. Noble & Co. and Heintz Bros. Passing to the 6th we meet the Wadsworth Watch Case Co., A. C. Becken, O. W. Wallis & Co., George H. Fuller & Son, T. W. Adams & Co. and Jules Racine & Co.

The 5th finds us in the home of the watch manufacturer and jobber, including such houses as the American Waltham Watch Co., M. A. Mead & Co., Keystone Watch Case Co., Courvoisier-Wilcox Mfg. Co., Jos. Fahys & Co., Brooklyn Watch Case Co. and New York Standard Watch Co.

On the 4th are found G. W. Marquardt & Sons, Stein & Ellbogen Co., Crescent Watch Case Co., Louis Manheimer, M. F. Barger, Western Watch Case Co. and Wאלach & Schiele.

F. M. Sproehle & Co. and C. H. Knights & Co. have elegant salesrooms on the 3d floor, and here we also meet the Self-Winding Clock Co. and J. W. Forsinger.

Pitkin & Brooks display porcelain and art wares on the 2d, and also have a store on the street level. Thence we pass to the retail house of Hyman, Berg & Co., who have



COLUMBUS MEMORIAL BUILDING.

HOME OF THE CHICAGO JEWELERS' ASSOCIATION.

ing center of western commercial life.

In jewelry manufacturing Chicago is not strong and comparatively little in this line is done, but as a central supply depot for placing the products of eastern factories in the hands of dealers in the great west, she

too. Aikin, Lambert & Co., Aikin-Lambert Jewelry Co., S. N. Jenkins, A. H. Reinke, F. A. Buck, and C. T. Wittstein engage our attention here. On the 7th floor a pleasant call is made on Abner Hurd, at the handsome rooms of the Chicago Jewelers' Asso-



MASONIC TEMPLE.

the double store on the corner of State and Washington Sts., and our visit to the jewelery palace is completed.

North one block, at the northeast corner State and Randolph Sts., stands the Masonic Temple, also illustrated herewith,



*Pairpoint*

# MANUFACTURING COMPANY.

## Gold and Silver Plate



No. 3749. MATCH HOLDER.

WE ARE MAKERS OF THE  
LARGEST AND LOWEST PRICED

.....LINE OF.....

“Crown Pairpoint” China,  
Rich Cut Glass,

Fine Decorated Art Goods,

.....TO BE FOUND IN THIS COUNTRY.

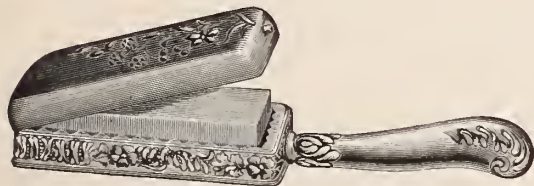

No. 2832. KNIFE SHARPENER.



No. 4908. SMOKING SET.

“WHEN IN DOUBT”

--- BUY ---

✻ PAIRPOINT GOODS.

Factories, New Bedford, Mass.

### HOLIDAY NOVELTIES

::::: OF EVERY DESCRIPTION.

**FREE**

OUR LATEST

SILVERWARE CATALOGUE No. 10, or  
CUT GLASS CATALOGUE No. 11

Will be mailed you upon receipt of address



SALESROOMS:

NEW YORK, 46 Murray Street.

CHICAGO, 224 Wabash Avenue.

SAN FRANCISCO, 220 Sutter Street.

MONTREAL, P. Q., Temple Building.

We sell to the legitimate Jewelry and Stationery  
trade only.



CHOICE PAPERS

MAKERS OF

## FINE STATIONERY

For Correspondence, Wedding and Business Use, handsomely  
boxed, specially suited to the Jewelry Trade.

18 MURRAY STREET, NEW YORK.

### FLAT WARE AND HOLLOW WARE STAMPED



IS THE GENUINE.

Manufactured by

WM. ROGERS M'F'G CO.,  
HARTFORD CONN.

H. M. RICH & CO.,  
Jewelry · Auctioneers,  
21 School Street.  
BOSTON. MASS.

### CROUCH & FITZGERALD.

Jewelry Trunks  
and Cases,  
161

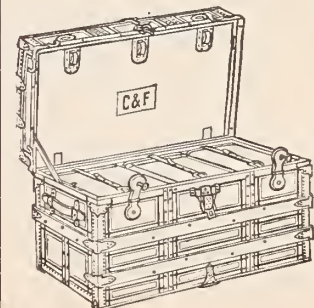

Broadway,  
Bet. Cortlandt and  
Liberty Sts.,  
688 B'way,  
701 6th Ave.,  
NEW YORK

# R. WALLACE & SONS MFG. CO.

## SILVERSMITHS,

WALLINGFORD, - - - - - CONN.



No. 20. FLASK.

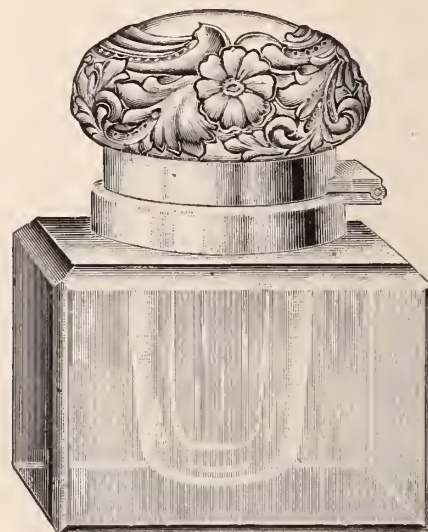

No. 53. INK BOTTLE.  
CHASED TOP.

Trade Mark.

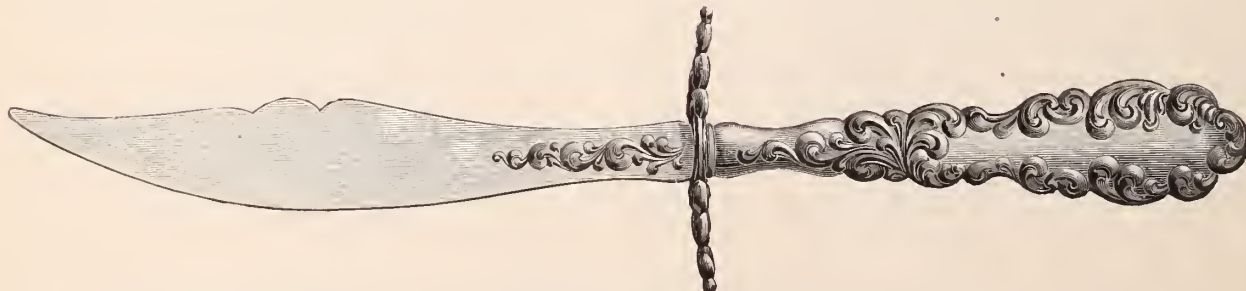

No. 39. PAPER CUTTER.

NEW YORK  
226. FIFTH AVENUE.

SAN FRANCISCO  
120 SUTTER STREET.

CHICAGO  
86 WABASH AVENUE.

which also is a caravansary for jewelry firms, principal of which are A. Hirsch & Co., M. S. Fleishman & Co., Swartchild &

business offices, salesrooms and local factory.

Crossing State St., adjoining the Colum-

Titus, Schauweker & Chalmers, United States Watch Co., of Waltham, and Reed & Barton, with their choice silver wares.

Again going south, at 113-115 State St., is the large establishment of B. F. Norris, Alister & Co. on the 2d floor, with several manufacturing shops above. At the northeast corner State and Madison Sts. are the Juergens & Andersen Co., and at the northwest corner, the Champlain building, a number of firms, of whom the principal are H. F. Hahn & Co., J. H. Purdy & Co., F. E. Morse Co. and the Wendell Mfg. Co. Between Madison and Monroe Sts. on the east side of State St., are some of the heaviest houses of the city, old established houses of an even international reputation. At 137-139 State St. the great house of the Gorham Mfg. Co. need no words of commendation. Benj. Allen & Co., detailed elsewhere in this number, occupy the 2d and 3d floors of the building illustrated on page 9—the 2d as a salesroom and the 3d for stock and shipping rooms, etc. Simpson, Hall, Miller & Co. take the entire fourth floor of 141-143. Heavyweights are again encountered at 149-151 State St. in the mammoth house of Otto Young & Co., 2d floor; Seth Thomas Clock Co. 3d floor; and Towle Mfg. Co., 3d. floor; E. V. Roddin & Co. and G. W. Hook, manufacturer, occupy the 4th floor. At No. 147 are the four floors of the Meriden Britannia Co., replete with plated lines and shipping and repairing facilities. Nearly opposite, on the west side of the street, is the optical house of Chambers, Inskeep & Co. The third floor of No. 155 introduces us to Homan Silver Plate Co. and A. & L. Felsenthal have the 3d floor of No. 158. At the



DENNISON MFG CO.—R. WALLACE & SONS MFG. CO.

Co., and Katlinsky & Gatzert Co., besides many manufacturing shops and prominent lamp houses. The Winslow & Penney Co., with their wheel-cutting machinery and demagnetizing apparatus are an interesting house on the 6th floor. The old established house of Giles, Bro. & Co. continue a retail business on the ground floor corner.

A block south and on the opposite side of State St., at the northwest corner of Washington St., is the Lapp & Flershem building shown in the illustration. Lapp & Flershem occupy the second floor. On the fourth are Simons, Bro. & Co., B. Grieshaber, F. H. Jacobson & Co., J. Milhening, and C. D. Peacock's shop, the latter house having the retail corner on the street. A few doors north at 86 State St., Glickauf & Newhouse have spacious salesrooms on the second floor, well stocked with tools and materials. The third floor is occupied by C. F. Happel & Co.

Leaving here and going one-half block west on the north side of Washington St., we come to the Institute of Arts building, 63-69 Washington St. Goldsmith Bros., refiners and assayers, occupy the 4th floor and basement. The 3d introduces us to the Holmes & Edwards Silver Co. and the Manhattan Silver Plate Co., and near by are R. M. Johnson and the Planchamp & Becker Co. Descending to the 2d, the Geneva Optical Co. are found in possession of this and the 1st floor, comprising the

bus building, stands the Venetian building, on the south side of Washington St. Here



VIEW SHOWING JEWELRY ESTABLISHMENTS WE ALL KNOW.

are located Alfred H. Smith & Co., the E. Howard Watch & Clock Co., Taylor &

northeast corner of State and Monroe Sts. M. C. Eppenstein & Co. are the most

**G. W. MARQUARDT & SONS,**  
 WHOLESALE JEWELERS.  
 ANYTHING YOU NEED.  
 103 STATE STREET, CHICAGO.



SPECIAL SELLING AGENTS  
**DUEBER-HAMPDEN WATCHES.**  
 Leaders in Uniform Low Prices.  
 We deal with Jewelers Only.  
 No Goods Sold at Retail.  
 We would like to Receive your Mail Orders.

GOODS THAT ARE SELLING.

**Sterling Silver Belts Complete with Silk Webbing.**  
 ASSORTED COLORS. PRICES EACH. SUBJECT TO CATALOGUE DISCOUNTS.



No. 4949. Plain Satin, "Military Style," Good Weight, Suitable for Monogram, - - - - - \$4.12

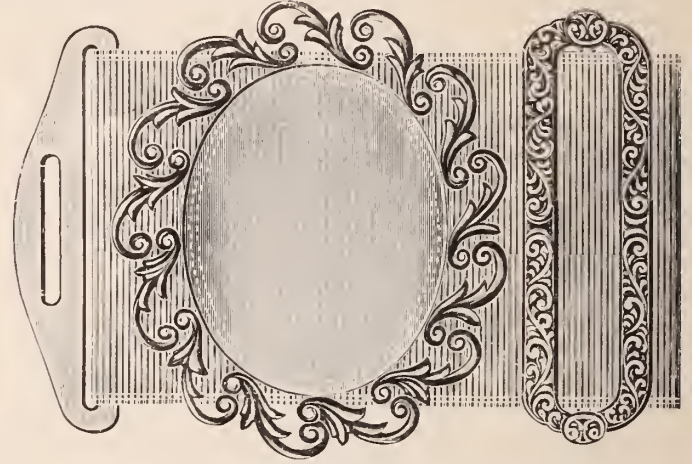

No. 4953. Sterling Silver, Good Weight, Plain Satin Center, Suitable for Monogram, - - - \$3.00

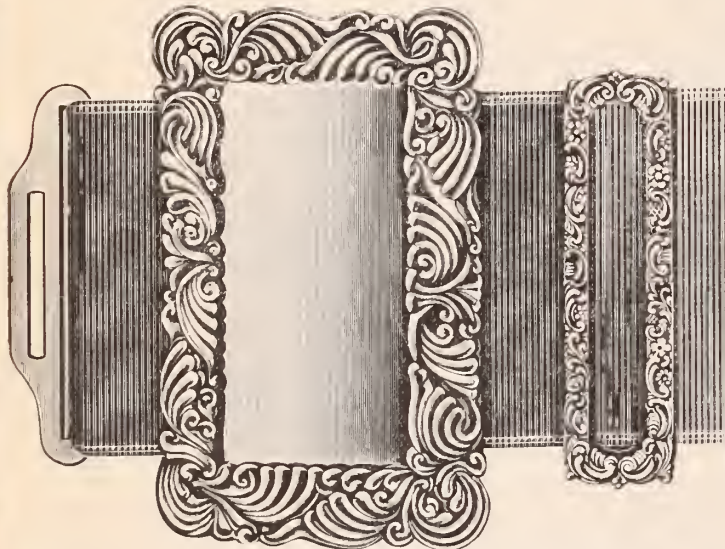

No. 4952. Sterling Silver, Good Weight, Plain Satin Center, Suitable for Monogram, - - - - - \$2.00

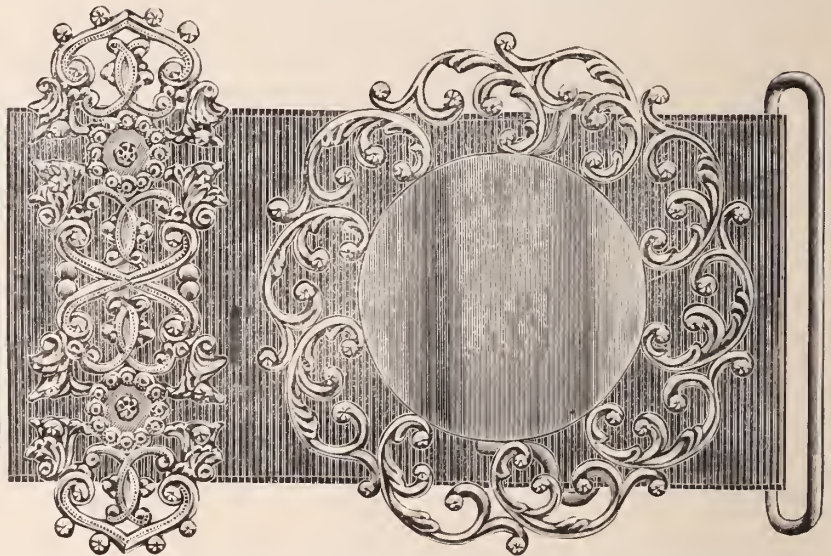

No. 4955. Silver Plated, Plain Satin Center, Good Weight, Four Assorted Shapes, all Suitable for Monogram, - - \$1.50

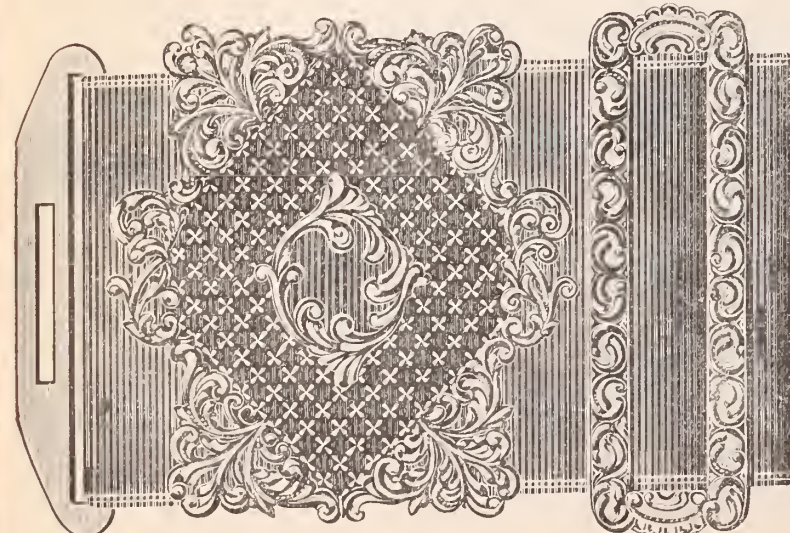

No. 4951. Sterling Silver, Open Work, Good Weight, - - - - - \$4.80

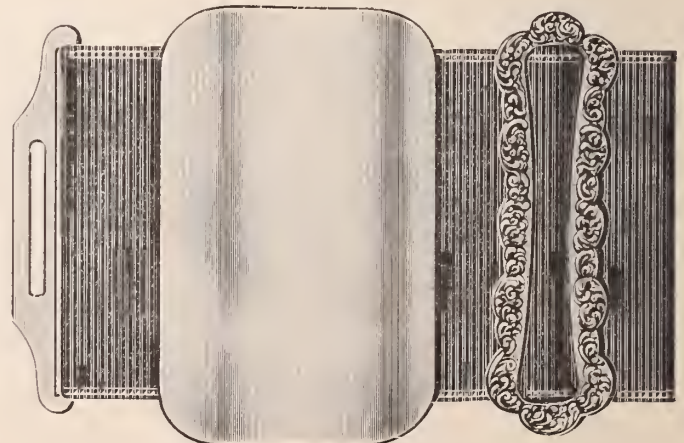

No. 4954. Sterling Silver, Good Weight, Suitable for Monogram - - - - - \$2.66

If you are wanting an assortment of Sterling Silver Novelties, send to us. We lead the world in uniform low prices. A bold statement, but it's true. If you are a watchmaker, or employ one, send for our new 500 page Illustrated Catalogue.

prominent among the houses there located.

While Spaulding & Co. are to be found at State and Jackson Sts., and several manufacturing plants and agencies lie between there and Monroe St., the "Maiden Lane" of Chicago, if confined to one street, would be the district limited by Monroe St. on the south and the Masonic Temple on the north. But a few years ago all the business in a jobbing way was confined within those limits. Then Wabash Ave. advanced its claims as a business thoroughfare which led to the establishment of a number of interests there, particularly in silver plate and clock lines. By the completion of the Columbus Memorial building, the tendency that was then ready to set in toward an advance of the jobbing houses southward was arrested and the trade became even more centralized than before. A general view of the western "Maiden Lane" is given on the first page.

Here we are diverted from State St. to visit the general offices of the Elgin National Watch Co., at 78 Monroe St., wherefrom emanate the methods of distribution of their enormous production. At the northeast corner Monroe and Dearborn,

Bailey, whom every one knows. Returning to Madison St. we visit the silver plat-

manufacturing optical house of F. A. Hardy & Co., and next door, at Nos. 42-44, G. A. Webster, representing also as western agent, the A. F. Towle & Son Co. and E. G. Webster & Son. Passing on to Wabash Ave. we call at No. 86, the western home of R. Wallace & Sons Mfg. Co., and immediately south the Dennison Mfg. Co., which are shown in the illustration on page 7. Hamilton & Rogers Co. are located at Nos. 110-112, and Theodor Shrader & Co. and Barbour Silver Co. occupy the northeast corner of Wabash and Madison. Thence we go to the finely arranged salesrooms of the Ansonia Clock Co. and the Meriden Silver Plate Co. (shown in cut) at 133-135 Wabash. Directly across the street an elevator is taken for the Waterbury Clock Co.'s salesrooms, and at No. 211 the New Haven Clock Co. are visited. A little further down on the east side of the avenue, at No. 124 are the very handsome salesrooms of the Pairpoint Mfg. Co., showing a grand display of silver and cut glass, with elegant surroundings.



BENJ. ALLEN & CO.—SIMPSON, HALL, MILLER & CO.

ing plant of Chas. A. Allen at 100-102; thence pass to L. Manasse, 88 Madison St., and crossing State St. find the Wm. L.

These comprise the leading features of interest in the central district of the jobbing trade. The Chicago and Aurora Smelt-



SOME OF THE HEAVY-WEIGHTS.



ANSONIA CLOCK CO —MERIDEN SILVER PLATE CO.

one meets the well-known houses of Bates & Bacon, Ostby & Barton, and Foster &

Gilbert Clock Co. in convenient salesrooms at 54-56 Madison St. At Nos. 46-48 is the

ing and Refining Co. in the Woman's Temple, corner La Salle and Monroe Sts.; W. S.

# OUR LEADER.

THE "ACME" LATHE  
IS NICELY NICKEL-PLATED AND WELL FINISHED THROUGHOUT.

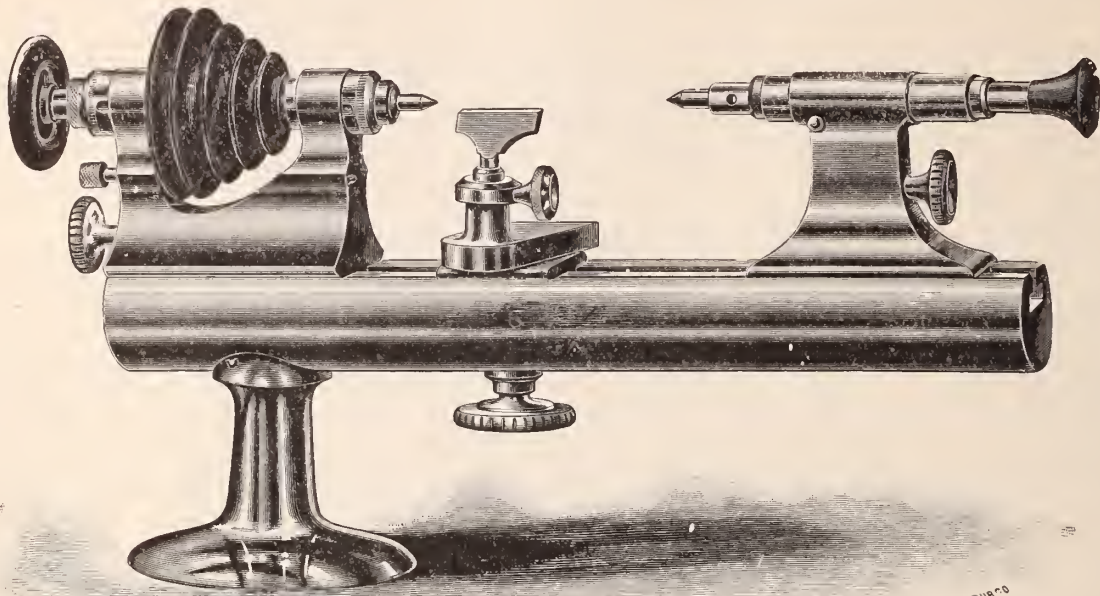

WE GUARANTEE THE  
"ACME" LATHE  
TO BE HARD AND TRUE.

THE GENUINE "ACME" LATHE, No. 1 x 2 HARD.

Guaranteed to be hard and true. Dimensions of Lathe:--Length of bed, 9.50 inches; bed to center, 1.75 inches; swing, 3.50 inches.

Same size in every respect as the No. 1 x 2 Moseley, with which all parts and attachments will interchange. Combination consists of: 1 Lathe, No. 1 x 2 hard; 10 Wire Chucks; 3 Step Chucks; 1 Screw Chuck; 6 Brass Cement Chucks, 1/4 inch; 1 Brass Cement Chuck, 1/2 inch; 1 Brass Cement Chuck, 1 inch; 2 Steel Tapers; 9 feet Belting; 1 Oak Chuck Box

**\$19.50**

If not satisfactory after 10 days trial, Lathe can be returned and Money will be Refunded.

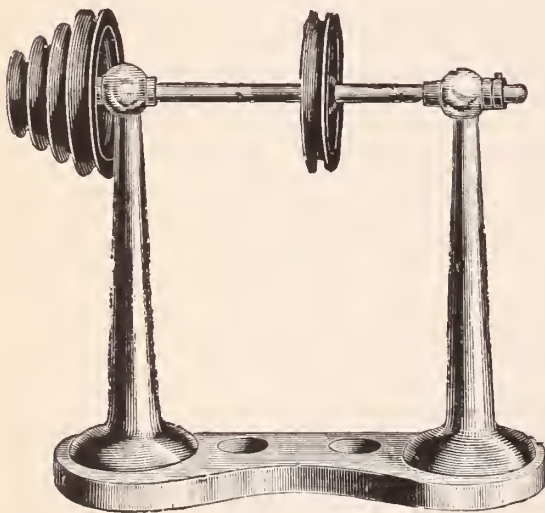

THE "ACME" COUNTERSHAFT.

Nickel plated, runs in babbitt metal bearing, - \$1.25

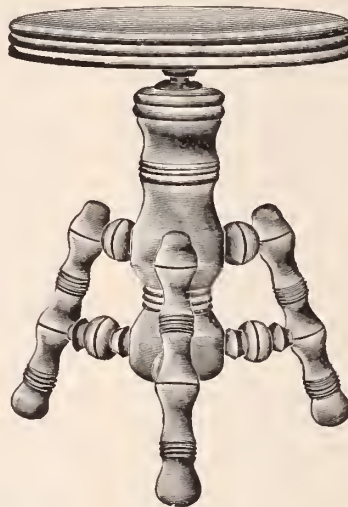

THE "G. & N." WATCHMAKERS' STOOL.

Hardwood Seat, 13 inches in diameter, finished in Ebony, Oak, Walnut and Mahogany. The best made.

Price - - - - - \$1.50

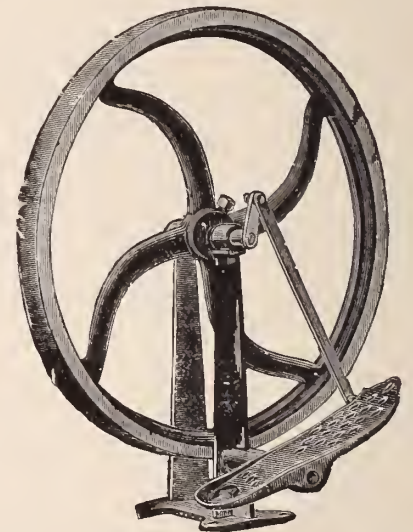

THE "ACME" HEEL AND TOE FOOT WHEEL,

\$2.00

ALL PRICES ARE SUBJECT TO 6 PER CENT. DISCOUNT FOR CASH.

Any of the above articles at price given or the entire outfit, consisting of one "Acme" Lathe, with 14 chuck combination, as above described, one "Acme" Foot Wheel, one "Acme" Countershaft, and one G. & N. Watchmakers' Stool, for the next 30 days for **\$23.90**

**GLICKAUF & NEWHOUSE, 84 & 86 State Street, Chicago, Ill.**

& J. B. Wilkinson, on Superior St.; Harding Bros., 1036 Lincoln Ave., and others

What a remarkable change has been effected in so short a time as has passed



GENEVA OPTICAL CO. HOLMES & EDWARDS. MANHATTAN SILVER PLATE CO. GOLDSMITH BROS.

that do not now come to mind, are houses that are worthy inspection.

since Isaac Speer, the first jobber first led the way in 1855!

**George Wilkinson's Will Entered For Probate.**

PROVIDENCE, R. I., Jan 25.—The will of the late superintendent George Wilkinson, of the Gorham Mfg. Co., was entered for probate in the Municipal Court before Judge Spink this morning. The will makes no public bequests and leaves the whole estate intact among the members of the family. John F. P. Lawton and the deceased's son, William S. Wilkinson, are named as executors and trustees of the estate, exempt from giving bond.

The first provision sets aside for the sole use of his widow, Harriet Wilkinson, the household estate and all the household effects and horses and stable equipments and an absolute bequest of \$50,000 in common stock, par value, of the Gorham Mfg. Co. To his sister, Mrs. Anna Dillon, of Montpelier, Vt., he bequeaths \$2,000. The residue of the estate he places in the hands of his trustees, to be held in trust for the benefit of his widow, who is to receive all incomes after all expenses have been paid. At her death the estate is to be equally distributed among his ten children, Mrs. Jessie Crooker, Walter Wilkinson, William S. Wilkinson, Arthur W. Wilkinson, John B. Wilkinson, Mrs. Amey H. Jackson, Mrs. Harriet S. Taylor, Mrs. Esther Ann Hull, Mrs Ruth Wheaton and Robert Wilkinson.

Loans of \$5,000 to Walter; \$5,000 to William S.; \$3,000 to Arthur W.; \$5,000 to John B. and \$3,000 to Robert are to be added to the inventory and deducted from the shares of these children. It is understood that the inventory of the estate will be about \$150,000. The witnesses of the will are Theodere A. Barton and Frederick C. Lawton.

**Jno. W. Reddall & Co.,**

107 HAMILTON ST.,

NEWARK, N. J.

**SIDE COMBS** in fourteen karat gold.

*A great variety of patterns at prices within reach of all.*

**KELLER, ETTINGER & FINK,**

SELECTION ORDERS SOLICITED.

24 JOHN STREET, NEW YORK.

DEALERS IN

MOUNTERS OF

IMPORTERS OF

**American Watches.**

**Fine Diamond Jewelry.**

**Diamonds.**



## HISTORY OF THE CHICAGO JEWELERS' ASSOCIATION.

CHICAGO, Jan. 25.—A well remembered truism of childhood's teaching, that "great oaks from little acorns grew," is paralleled in the remarkable growth of the Chicago Jewelers' Association, which, as a corporate body, from the acorn of small beginnings has grown to be a tower of strength in western commercial life. Dean Swift has immortalized the separate races of the Lilliputians and the Brobdingnagians; the Chicago Jewelers' Association has shown to the world the development of a Lilliput into a Brobdingnag whom the thongs of neither tariff reform nor currency legislation can long keep bound. The tracing of such a development is not without its interest to members of the present day, and as a matter of practical business is worthy of emulation by trade associations which have not already done so.

In a gathering of a dozen jobbers of jewelry in a little back room in this city, May 20, 1876, was sowed the germ that, nurtured by the genial warmth of enthusiastic but withal conservative leaders, has come to mature growth the fruitage of which has been of such marked value to the members. This small gathering consisted



GEORGE M. WALLACE.  
VICE-PRESIDENT.

of W. A. Giles, L. J. Norton, H. Oppenheimer, Benj. Allen, Otto Young, C. Wendell, J. H. Weber, L. W. Flershem, W. M. Alister, S. H. Hale, W. F. Tompkins, and D. R. Grow. A permanent organization was effected June 16th following, with these firms as members: C. Wendell & Co., W. B. Clapp, Young & Co., Waterbury Clock Co., Benj. Allen & Co., Giles, Bro. & Co., Weber & Co., Elgin National Watch Co., H. F. Hahn & Co., American Watch Co., Lapp & Flershem, B. F. Norris, Alister & Co., American Clock Co., Henry Oppenheimer & Co. and N. Matson & Co. Of these C. Wendell & Co. and Weber &

Co. have passed out of existence; Giles, Bro. & Co. retired from the wholesale business; N. Matson & Co. went out of the job-



GROVE SACKETT.  
PRESIDENT.

bing trade and were succeeded by Spaulding & Co. in the retail; the American Clock Co. became the Seth Thomas Clock Co.; the American Watch Co. changed its name to the American Waltham Watch Co.; Henry Oppenheimer moved to New York; W. B. Clapp, Young & Co. developed into Otto Young & Co.

Effective co-operation during the next four years led to their incorporation May 7, 1880, with the object of "cultivating friendly relations, promoting the interests of its members obtaining and distributing accurate and reliable information among such members as to the standing of jewelers," and other matters pertaining to their interests and welfare as business men. As year by year the progress of the association became more marked, the exigencies were met by a thorough systemizing of the office work and the employment of an assistant secretary. Clerical assistance has been added as required, office room increased, and departments added for the accomplishment of work not originally contemplated by the founders. Chief among these was a collection bureau, established in 1888, which has proved a valuable adjunct.

It would seem but natural to expect a slow growth in membership as the years advance, but this, it seems, is not the case with the Chicago Jewelers' Association. Since 1892, but three years ago, this commercial body has shown an increase in membership of 25 per cent. and at present the membership numbers 52, comprising the largest and strongest houses of the city, houses which owe their present

high position largely to the business ability of the very men who meet at the association rooms on the seventh floor of the Columbus Memorial building the first Tuesday of each month, to discuss the current topics of general trade interest. The hospitality of Chicago jewelers is proverbial. During the World's Fair the association as a body, not to be outdone by the individual members, opened handsome clubrooms in the Columbus Memorial building, established a bureau of information for visiting jewelers, and became the host to jewelers, strangers in this city, not only from various sections of the United States, but from many foreign countries.

A full list of the Association members follows: Benj. Allen & Co., Ansonia Clock Co., Courvoisier-Wilcox Mfg. Co., Crescent Watch Case Co., Dennison Mfg. Co., Elgin National Watch Co., Jos. Fahys & Co., Geneva Optical Co., Wm. L. Gilbert Clock Co., Gorham Mfg. Co., H. F. Hahn & Co., C. F. Happel & Co., F. A. Hardy & Co., A. Hirsch & Co., Holmes & Edwards Silver Co., E. Howard Watch & Clock Co., Juergens & Andersen Co., Keystone Watch Case Co., C. H. Knights & Co., Lapp &



J. A. TODD.  
SECRETARY AND TREASURER.

Flershem, Lyon & Healy, L. Manheimer, G. W. Marquardt & Sons, M. A. Mead & Co., Meriden Britannia Co., Meriden Silver Plate Co., F. E. Morse Co., H. Muhr's Sons, New Haven Clock Co., B. F. Norris, Alister & Co., Pairpoint Mfg. Co., Reed & Barton, Robbins & Appleton, Rockford Silver Plate Co., Rockford Watch Co., Rogers & Hamilton Co., Roy Watch Case Co., Seth Thomas Clock Co., Simons, Bro. & Co., Simpson, Hall, Miller & Co., Alfred H. Smith & Co., F. M. Sproehle & Co., Adolphe Schwob, Stein & Ellbogen Co., Towle Mfg. Co., R. Wallace & Sons Mfg.



=The  
=Directors  
=of the

=Chicago  
=Jewelers'  
=Association.

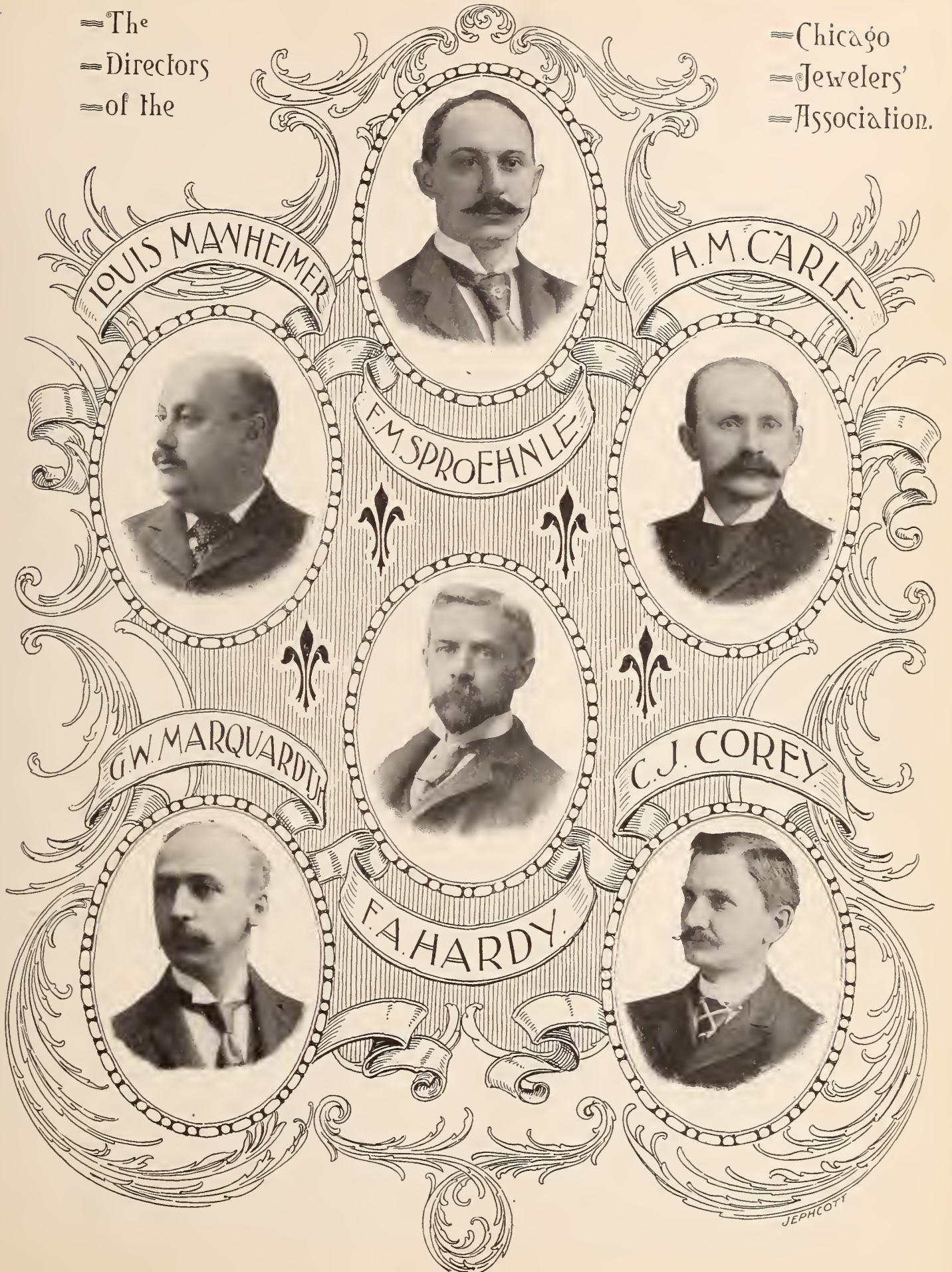

Co., O. W. Wallis & Co., Waterbury Clock Co., Waterbury Watch Co., Western Watch Case Mfg. Co., W. S. & J. B. Wilkinson, Otto Young & Co.

The business merits of the members of the Chicago Jewelers' Association are known to all the world; the banquet of last evening was an eloquent testimonial to their services as useful members of the world social.

#### Dull Business Drives Samuel Goodman to the Wall.

NEW HAVEN, Conn., Jan. 24.—Samuel Goodman, the Chapel St. jeweler, made an assignment in the Probate Court Tuesday morning through his attorney, David Strouse, naming jeweler Samuel H. Kirby as the trustee. Pending further action, at the request of Attorney Strouse, a precept was issued from the Court to Deputy Sheriff James H. Peck to take charge of the store.

The assets are said to be equal in amount with the liabilities, ranging in the neighborhood of \$20,000. Accountants have been at work preparing a statement for the creditors. Dull business is the prime cause of Mr. Goodman's condition, and it is natural that in these times those in the jewelry trade are the first to suffer.

Mr. Goodman is a nephew of Edward Engel, the wealthy jeweler and pawnbroker of this city, whose estate is estimated at \$150,000. He was for years in his

uncle's store here. Notwithstanding his popularity he has attended strictly to his business, which was supposed to be profitable.

A circular letter has been sent out by Mr. Goodman to his creditors in New York and Boston asking that they compromise with him on a basis of 40 per cent. on the dollar. A meeting of the creditors has been called for Monday morning, Jan. 28, at the office of Herzog, Goldsmith & Frank, New York.

#### Aftermath of the Fire at the Winsted Optical Co.'s Works.

WINSTED, Conn., Jan. 24.—A meeting of the directors of the Winsted Optical Co. was held Jan. 21st. The situation regarding the recent fire was discussed, but no decisive action was taken, and the meeting was adjourned until after the insurance has been adjusted. The company expect to resume business as soon after the adjustment as possible. The company have been doing a good business and their capital was recently increased from \$30,000 to \$45,000.

A great deal of their fine machinery is damaged beyond use. The company, about two years ago, bought out Smith, Lesquerieux & Co., Springfield, and the price paid was about \$10,000. All this machinery was in the factory. In a graceful, open letter, from secretary F. A. Clark, the fire department is highly praised.

#### The Circular's Silver Stamping Bill in the Arkansas Legislature.

LITTLE ROCK, Ark., Jan. 22.—Mr. Gray introduced to-day House Bill No. 66, an act to regulate the sale of goods marked "sterling silver;" misdemeanor to sell or keep such goods unless .925 pure silver, etc.

This measure is the one drafted by THE JEWELERS' CIRCULAR.

#### The Incorporation of the F. M. Whiting Co.

NORTH ATTLEBORO, Mass., Jan. 25.—The F. M. Whiting Co. have incorporated with a capital stock of \$100,000 in single shares of \$100 for the manufacture and sale of silver, jewelry and novelties.

The promoters are Florence L. Whiting and Josephine S. Whiting.

Wm. H. Dietz, 117 Dearborn St., Chicago, has just published the fourth edition of his engravers' monogram book, containing more than 2,200 different designs arranged alphabetically, and indexed so one can find any monogram in 10 seconds' time. The letters are in outline, so that one can see how the letters are intertwined. They can thus be enlarged or reduced quickly. This book does away with the making of special designs to show to customers. The book can be ordered from your jobber, or from Mr. Dietz direct, as announced in his ad. elsewhere in this issue.

THE LINE OF THE NOW WELL KNOWN

## L. E. & Co. SPRING BACK STUDS



WILL BE UNSURPASSED FOR  
PRICE, VARIETY, STYLE AND WORKMANSHIP.

..... WE MAKE .....

**LINK BUTTONS** in popular patterns at right prices

**GENTLEMEN'S RINGS** with all the correct Stones, Jades, Jaspers, Cornelians, Garnets, Etc. **SIGNET RINGS.**

**LADIES' RINGS** in the greatest variety of combinations.

**CHILDREN'S RINGS** in all styles.

**STONE SEALS.** A full line in Jades, Jaspers and Sardis.

THE INTRODUCTION OF NEW MANAGEMENT AND METHODS IN OUR FACTORY WILL ENABLE US TO MAINTAIN OUR REPUTATION FOR EXCELLENCE OF PRODUCTION, AND AT THE SAME TIME PLACE OUR GOODS BEFORE THE TRADE AT PRICES THAT WILL COMMAND ATTENTION



OUR TRADE MARK.

## LARTER, ELCOX & Co.,

21 & 23 MAIDEN LANE, NEW YORK.

Factory, Cor. Mulberry and Chestnut Sts., Newark, N. J.

# ADELPHI SILVER PLATE CO.,

JOHN SCHIMPF & SONS, Proprietors.

Manufacturers of Finest Grades of

## ELECTRO SILVER PLATED WARE.

Original and Artistic Goods of our own Design Heavily Silver Plated on Hard White Metal.

NEW YORK OFFICE,  
62 JOHN STREET,

CHICAGO OFFICE,  
L. SELIGSBERGER,  
34 MONROE STREET.

FACTORIES,  
124-130 PEARL STREET,  
BROOKLYN N. Y.

AN EXCELLENT SELLER!!!

Our No. 15 "Antique" Tea Set.  
Five pieces. One-third size.  
Cream and Spoon Holder. Gold  
lined. All satin, bright cut.



No. 25. Fern Dish.

We offer one of the finest and most  
complete lines in these goods  
ever shown.





# We beg your pardon

for any seeming delay in filling your orders during the Holiday rush, but we weren't entirely to blame when you think of it.

We repeatedly warned you to send in your orders early, and not get left; we made provision by doubling our former stock orders, and increased our force of employees 33 $\frac{1}{3}$  per cent., but still couldn't take care of the rush as promptly as we would have desired, and we were compelled to have our employees **work Day and Night during December** to keep up with the ever increasing demand made of us, and boarding them at a neighboring hotel to save time.

There is, however, one gratifying truth and thought back of it all **both for you and ourselves**, and that is, that **Our Prices were recognized by close buyers** as being the lowest, and which they took advantage of.

Below examine **Opening and Closing Hours** of our place of business during December 1894, as furnished by the Chicago Electric Protective Co.:

## OPENING AND CLOSING TIME FOR DECEMBER, 1894.

1894	<u>CLOSED</u>	<u>OPENED</u>	1894	<u>CLOSED</u>	<u>OPENED</u>
Dec. 1	11.59 P. M., Evening,	7.45 A. M.	Dec. 14	12.35 A. M., Morning,	7.48 A. M.
" 2—Sunday,	1.42 " " "	11.15 "	" 15	3.09 " " "	7.48 "
" 3	11.11 " " "	7.25 "	" 16—Sunday,	5.40 P. M., Evening,	10.42 "
" 4	11.55 " " "	7.33 "	" 17	1.58 A. M., Morning,	7.05 "
" 5	11.07 " " "	7.40 "	" 18	2.09 " " "	7.51 "
" 6	3.45 A. M., Morning,	7.42 "	" 19	2.31 " " "	7.48 "
" 7	1.48 " " "	7.40 "	" 20	3.55 " " "	6.10 "
" 8	12.10 " " "	7.57 "	" 21	3.02 " " "	7.20 "
" 9—Sunday,	4.35 " " "	11.23 "	" 22	1.32 " " "	7.19 "
" 10	12.43 " " "	7.48 "	" 23—Sunday,	6.53 P. M., Evening,	9.45 "
" 11	4.00 " " "	7.48 "	" 24	11.16 " " "	7.40 "
" 12	4.30 " " "	7.58 "	" 25		
" 13	12.36 " " "	7.40 "	" 26	1.20 A. M., Morning,	7.18 "

### ONE THING TO REMEMBER

 that our prices for 1895 will always be bottom, and such that will prove interesting to you as a close buyer. We want your trade. Wishing you a Prosperous and Happy New Year, we remain,

**F. M. Sproehnle & Co., Chicago,**  
103 STATE STREET, COLUMBUS MEMORIAL BUILDING.

WATCH THE RESULTS OF **our Salesman** 1895 CATALOGUE OPEN ON YOUR SHOW CASE



## EIGHTEENTH ANNUAL BANQUET, AT KINSLEY'S,

THURSDAY EVENING, JANUARY 2, TH.

CHICAGO, Ill., Jan. 25.—It was a great night. The rocky hillsides of New England, fertile plains of the great Central West, and orange groves of California were all represented in the participants at the eighteenth annual banquet of the Chicago Jewelers' Association at Kinsley's, last evening. It was a night long to be remembered. Sumptuous appointments, fine music, both vocal and orchestral, and a large number of guests made it a great success. The invitations read 7 P. M., but as early as 6.30 the reception committee assembled and at 6.45 the members and their friends began to arrive, and each

presented his credentials to the banqueting-house."

In the large reception room on the third floor, where the jewelers assembled before passing to the banqueting hall, it was a pleasing sight to note the demonstrative proof of friendship that existed between men of the same calling. They were all brothers of the great family of jewelers; care was thrown to the winds, thoughts of business banished, and all met on the equal ground of genial companionship. And in the short time allowed for social intercourse their acquaintanceship was furthered and more closely cemented.

On to the banquet was sounded at 8 o'clock, and the jewelers repaired to the sumptuous hall on the 4th floor set apart for the occasion. To the accompaniment of soft strains of music floating out from the orchestra stationed in the gallery they entered, and then President Sackett rapped for order.

The tables were arranged in the form of the letter E with the table of honor forming the upright and the tables branching from this nearly three times the length of the main table. In the place of honor sat

President Grove Sackett; on his right were the Rev. Dr. Lawrence, pastor of the Second Baptist Church; Lyman J. Gage, president First National Bank; Otto Young; Judge John Barton Payne, and F. E. Morse. At his left sat J. P. Byrne, toastmaster of the evening; Hon. Thomas Cratty, H. F. Hahn, J. L. Shepherd, president of the Commercial Travelers' Club, New York; and F. C. Elliott. At the right end of the table of honor were George M. Wallace, vice-president of the Chicago Jewelers' Association, and Robert Morris; at the left end, Holmes Hoge and Abraham Hart. The three lateral tables were presided over respectively by A. L. Sercomb, J. F. Talbot, and J. A. Todd.

Never was better taste shown in floral decoration and general arrangement of the hall. At intervals on the tables stood tall masses of white lilies, separated by huge epergnes of fruit and bowls of red and day-break carnations, the whole made complete by roses and ferns lying loosely on the cloth.

The menu was an artistic bit of work, consisting of three leaves of heavy card printed in script and fastened with baby blue gros grain ribbon into a lavender cover with gold inscription and a copy of the seal of the city of Chicago in colors in the upper right-hand corner.

In its literary feast the association is to be congratulated on having secured the master minds on the subject matters dwelt upon, as shown in the programme as arranged. The first page contained the menu, the second the following programme:

### AFTER DINNER.

*Introductory,* The President.  
 Toast Master, Mr. J. P. Byrne.  
*The City of Chicago,* Mr. John L. Shepherd.  
*Some Words on the Currency,* Mr. Lyman J. Gage.

### Civic Virtue,

Measures are good, but men are needed,  
 Behind the law, the loyal citizen.

Prof. Emil G. Hirsch.

### The Growth of Ethics in Business,

Hon. John Barton Payne.

### The New Woman,

Rev. Dr. Wm. N. Lawrence.

### College Men in Business,

Hon. Thomas Cratty,

The third page showed the officers as follows:

### THE CHICAGO JEWELERS' ASSOCIATION.

#### Officers and Committees.

Grove Sackett, President;

George M. Wallace, Vice-president;

Jas. A. Todd, Secretary and Treasurer.

Membership Committee. Finance Committee.

H. M. Carle,

G. W. Marquardt, Jr.

F. A. Hardy,

G. J. Corey,

F. M. Sproehle,

L. Manheimer.

#### BANQUET COMMITTEE.

A. L. Sercomb, Chairman, H. F. Hahn,

J. P. Byrne, Secretary, J. A. Todd,

J. F. Talbot,

Grove Sackett, Ex-officio.

#### RECEPTION COMMITTEE.

F. E. Morse, Chairman,

Lem W. Flershem,

M. N. Burchard,

A. Hirsch,

H. M. Carle,

M. A. Mead,

G. J. Corey,

Julius Schearing,

Max Ellbogen,

O. W. Wallis.

The individual arrangement of members and their friends, showing the various house parties, was as follows: Benj. Allen & Co., John A. Cox, Samuel W. Dripps; Ansonia Clock Co., C. F. Huntington; Courvoisier-Wilcox Mfg. Co., S. C. Payson; Geo. C. Gubbins, Arthur F. Smith; Dennison Mfg. Co., J. F. Talbot, E. C. Thomas, W. G. Walton, W. J. Wilton; Elgin National Watch Co., George Hunter, W. H. Cloudman, George E. Hunter, C. H. Smith, J. W. Forsinger, Wm. A. Purcell, O. W. Barrett, Wm. Geo. Prall, G. V. Dickinson, Jno. M. Cutter; Jos. Fahys & Co., Geo. Weidig, Wm. Oskamp; Geneva Optical Co., A. L. Smith; Wm. L. Gilbert Clock Co., Grove Sackett



J. P. BYRNE.

Frank C. Elliot; Gorham Mfg. Co., Henry S. Hyman, Morris H. Berg, Edward S. Hyman; H. F. Hahn & Co., Herman F. Hahn, Abraham Hart, Holmes Hoge, Harry W. Hahn, J. M. Joseph; C. F. Happel & Co., C. F. Happel; F. A. Hardy & Co., Almer Coe, John H. Hardin, E. S. Fowler; A. Hirsch & Co., A. Hirsch, Wm. Hirsch, Oscar Hirsch, R. Eiseman; Holmes & Edwards Silver Co., T. R. Barnes, Willis W. Brown; E. Howard Watch & Clock Co., H. E. Howard; Keystone Watch Case Co., H. M. Carle; C. H. Knights & Co., W. H. Gleason, F. G. Thearle, Jr.; Lapp & Flershem, Lem W. Flershem, Peter Lapp, E. P. Edwards, S. Milnor; Lyon & Healy, J. P. Byrne, J. P. Healy; L. Manheimer, W. S. Manheimer, M. Loeb; G. W. Marquardt & Sons, G. W. Marquardt Jr., C. G. Marquardt, A. W. Crawford; M. A. Mead & Co., Lieut. Brewer; Meriden Britannia Co., A. L. Sercomb, Hon. O. H. Horton, J. H. Hiland, Geo. F. Greenleaf, Frank Abbott; Meriden Silver Plate Co., Col. J. F. Turner; F. E. Morse Co., F. E. Morse, Noah Clark, Jas. W. Clark, Eugene McDonald, Frank H. Shearer; New Haven Clock Co., Geo. A. Jewett; B. F. Norris, Alister & Co., C. H. Spencer, S. C. Holland, Pairpoint Mfg. Co., G. J. Corey, O. H. Hall, S. M. Sturdevant; Reed & Barton, H. M. Lane; C. D. Peacock, C. B. Shourds; Robbins & Appleton, Ed Lake, R. A. Kettle, A. W. Goodrich, Sam L. Joseph; Rockford Silver Plate Co., Geo. B. Kelley; Rogers & Hamilton Co., J. K. Caldwell; A. C. Becken; Roy Watch Case Co., C. S. Shepard; Seth Thomas Clock Co., Geo. W. Church, G. W. Payson, J. T. Glover; Simons Bro. & Co., E. A. Dorrance, Dr. J. W. Slonaker; Alfred H. Smith & Co., Elmer A. Rich, H. W. Allen, W. H. Vogell; Simpson, Hall, Miller & Co., M. N. Burchard; F. M. Sproehle & Co., F. M. Sproehle, A. W. Sproehle; Stein & Ellbogen Co., Sigmund Stein, Max Ellbogen, F. Le Brore, J. S. Townsend; Towle Mfg. Co., J. A. Todd, H. D. Stevens, Geo. D. Lunt, R. C. Demarest, George Hay; R. Wallace & Sons Mfg. Co., Geo. M. Wallace, Robert Morris; O. W. Wallis & Co., O. W. Wallis, H. C. Smith, J. K. Stevens; Waterbury Clock Co., C. J. Dodgshun, E. W.

Holden; Waterbury Watch Co., E. F. Strickland; Western Watch Case Mfg. Co., Marx Meyer; W. S. & J. B. Wilkinson, E. M. Lunt; Otto Young & Co., Otto Young, Julius Schnering, E. V. Roddin, Albert Miller; Association guests, Hon. Thomas Crathy, General H. W. Wheeler, Jno. P. Hopkins, H. J. Furber, L. J. Gage, Dr. W. M. Lawrence, Washington Hessing, Jno. Barton Payne, J. L. Shepherd, Abner Hurd, Prof. Emil Hirsch; press reporters, W. W. Wilcox, Loren Boyle, Stephen Parlin.

When the refreshment of the inner man had been concluded, President Sackett made the following brief introductory remarks:

#### GREETING OF PRESIDENT SACKETT.

*Gentlemen:*—Recently I attended a public meeting where the presiding officer, before commencing his speech, stated that for fear of being misquoted by the press he had written out what he had to say. I am a little in that position myself.

I not only esteemed it, gentlemen, an honor to meet so many eminent people, but it gives me great pleasure to extend a most hearty welcome in the name of the Chicago Jewelers' Association to every one present at this, our Eighteenth Annual Banquet. There has never been a time when I would have given more to have been an orator than at the present moment, but as that is an attainment I do not possess, my remarks will be brief, and you will soon have an opportunity to listen to the eloquent speakers who have kindly consented to address us.

Last year we did not hold our banquet as usual, and it was suggested, in view of the fact that so many unemployed persons were suffering from lack of the necessities of life, that members should contribute to aid those in distress, the amount usually expended at our annual banquet; and as much more as they could afford. Committees were appointed from members of this association and from members of the jewelry trade throughout the city, to solicit subscriptions from all who were engaged in the so-called jewelry trade or kindred lines. The result was that Mr. H. M. Carle, who acted as treasurer for the committees appointed, paid to the treasurer of the Central Relief Association \$13,847.68, which I am informed was the largest amount contributed by any one line of trade in Chicago. In justice to all it should be stated that many persons had made contributions direct to the Central Relief Association before the special committees were appointed to collect funds from jewelers, so the amount contributed by the jewelry trade must have to quite an extent exceeded the amount of which we have a record.

It is my sad duty to report that since our last banquet we have lost by death an honored resident member, Sebastian Andersen, president of Juergens & Andersen Co., and three non-resident members, Geo. R. Curtis, Hon. Samuel Simpson and Gurdon W.

Hull, all of whom were for a great many years recognized as leading and representative men in the silverware business. A committee from this association last July attended the funeral of Thomas Cogswell, who was not actively engaged in business at the time of his death, but was for many years an active member.

The recent report by our worthy secretary and treasurer, Mr. Todd, shows that our association is in good financial condition, and our office records show that for the year 1894 our business in the reporting department exceeded by 16½ per cent. the amount done in that branch any previous year since this association was organized. The collection department records show an increase of nearly 15 per cent. in the total amount collected for our members and over 20 per cent. increase in revenue for the association compared with the year 1893.

Notwithstanding the general depression in business I think our members have been very fortunate in the amount of business done and we have reason to congratulate ourselves on the satisfactory condition of our association, but at the same time it will be well for us to keep in mind the fact that we are living in an age of rapid progress, and that all leaders in religion, art science or business are constantly looking for new truths and improvements.

The suggestion I desire to make is that as an association and as individuals, we should aim to keep our standard high, with the hope that when another year has passed and we attend our next annual banquet we may all be better prepared to solve the problems of life and to do our duty as citizens of the best country on earth.

I fear I have already occupied more valuable time than I had a right to appropriate, and it now affords me great pleasure to introduce one of our distinguished members, who has kindly consented to act as toastmaster for the evening, Mr. J. P. Byrne. (Applause.)

The toast-master, Mr. J. P. Byrne, spoke as follows:

*Honored guests and fellow-members:* Our highly esteemed president has extinguished rather than distinguished me by saying to you almost everything I had intended to say, and with a dignity, elegance and eloquence that are at once my admiration and despair. I am somewhat in the condition of the amateur after-dinner speaker on the occasion of his first (and only) appearance in that role. Through some oversight on the part of the committee, he was placed about seventh on the list of speakers. He prepared a half-dozen choice stories to enliven his maiden effort, but became a little nervous when he heard the first speaker tell one of them with admirable skill; he applauded with a dry and hollow laugh the recital of another of his anecdotes by the second speaker; he spilled some ice water on his shirt front in an endeavor to wet his parched throat when he heard one more of his laugh-makers told by the third orator of the evening, and he kept shrinking in his chair as this was repeated by speaker after speaker until his turn was reached, when, upon his failure to arise, it was found that coma had set in. (Laughter) However, I am very glad for my own sake that I am not so far down on the list as to be in that gentleman's condition; there are a few things left for me to say, and among them is the fact that this is the eighteenth mile-stone

# TO RETAIL WATCH DEALERS.

**WALTHAM  
WATCHES.**

**THE BEST AND BEST  
KNOWN WATCHES  
FOR FORTY YEARS.**

The history of the AMERICAN WALTHAM WATCH COMPANY may be properly called the history of watch making in America. Entering, in 1854, a field hitherto held by the Swiss manufacturers, this Company established at once the principle of watch making by machinery as understood to-day, and the superiority of American Watches. Other concerns have sought to emulate the originality and progressiveness of the AMERICAN WALTHAM WATCH COMPANY, but the steady growth, during the past forty years, in the demand for Waltham watches has demonstrated their unrivalled popularity. The mechanical excellence of WALTHAM watches has been attested by the highest awards at international expositions.

WALTHAM watches embody the greatest achievements in Horology. They are made in sizes 0, 6, 16 and 18, in grades from seven to seventeen jewels, and are sold upon their merits. Every WALTHAM watch movement is guaranteed to be made of the best material and upon the most approved principles, and for any defect in material, workmanship or performance, under fair usage, the Company hold themselves at all times responsible.

**THE WALTHAM  
RETAIL REBATE IS  
A GUARANTEE OF  
PRICES.**

Dealers who are urged on any plea to purchase the indifferent product of other manufacturers, should bear in mind the advantages of handling WALTHAM watches exclusively. The WALTHAM rebate system, which was adopted more than ten years ago, guarantees every legitimate retail watch dealer in the United States or Canada against loss by changes in the prices of WALTHAM watches. This method of protecting the retail dealers has been conducted at an expense of several hundred thousand dollars. Supplementing the mechanical superiority of the watches themselves, it has afforded additional assurance that WALTHAM watches are the safest goods in the world to handle.

**THE PROFITS ON  
REPAIRING  
SECURED TO  
JEWELERS.**

The repairing of watches is an important branch of the retail jewelry business. It is well known that many persons not in the trade send watches direct to manufacturers for repairs, with the view of saving the profit which would otherwise go to the jeweler. We recognize the importance of protecting the retailers in this as well as in every other respect, and it is our rule to charge repairs through the trade only. Persons who are not dealers in watches are in each instance notified of this rule and are requested to indicate a retail jeweler through whom the package may be returned and the transaction effected.

**WALTHAM  
IMPROVED  
MOVEMENT  
BOXES.**

The compact and secure locking boxes in which WALTHAM watches are issued are a great improvement, wholly original with ourselves. These boxes insure safety in transit and freedom from dust or other annoyance incidental to the use of pasteboard holders. American Watch Co. First Quality 16 size and Vanguard movements are delivered in elaborate WALTHAM display boxes.

**FANCY DIALS.**

Fancy dials with Gold or Steel Louis XIV. hands are supplied on adjusted movements without extra charge.

**SIGNS AND  
ELECTROTYPES.**

Signs and electrotypes are sent, expressage prepaid, to watch dealers on request.

Correspondence upon the above or any other subjects of mutual interest is cordially invited.

**AMERICAN WALTHAM WATCH COMPANY,  
Waltham, Mass.**

February 1st, 1895

# EXTRACT FROM A SPEECH

WHICH MIGHT HAVE BEEN

## Delivered at the Annual Banquet of THE CHICAGO JEWELERS' ASSOCIATION.



“Mr. Chairman and Gentlemen :

“The illustrious speakers who preceded me here this evening have duly eulogized **Our Officers**, touched upon the marvellous development and growth of **Our Country**, paid a fitting tribute to **Our Guests**, done justice to **Our City** and tried to do the same for **The Ladies**, the latter a task which no speaker has ever yet fully accomplished. It remains for me to add but a few more flowers to the rhetorical bouquet, and I will do so by telling you that which as astute business men you are doubtless familiar with. I refer to the numerous good qualities of the **Old Reliable W. & S. B.★ Chains**. As a representative dealer I endorse them in the strongest manner, believing, as I do, that for style, finish, wearing qualities, price and selling powers, the chains made by W. & S. Blackinton, Attleboro, Mass., stand at the head. Now, as the reporters' axiom, “stop when you've told your story,” holds good equally with after dinner speakers, I thank you all for your courteous attention, and will conclude by wishing every success to W. & S. Blackinton and their specially excellent line.” (**Uproarious applause.**)





J. A. TODD.

## ADDRESS OF JOHN L. SHEPHERD.

*Mr. President and Gentlemen of the Chicago Jewelers' Association:*

No doubt many of you think it strange that I should come from the city of New York to respond to the toast, "The City of Chicago," but I assure you that I am not here as the representative of that envious element which can find no other encomium to pass upon your marvelous city than that of the "Windy City." As I came into the city of Chicago this morning and saw its marvelous growth and realized all the possibilities, all that might be said and all that should be said, I realized how impossible it was to pay tribute to the genius and skill of Chicago in the short time allotted to me here to-night. To me it is no less a pleasure, as it is an honor, to be invited here to pay tribute to the skill and the courage that within the lifetime of one generation has created this great city and placed it abreast with the foremost cities of the world, whose births are lost in the misty centuries of the past.

No doubt my coming here to-night to tell you of the glory of the city of Chicago will remind you of the legend of carrying coals to Newcastle, and again I assure you that I come here with no feeling of envy in my heart for the new glory the name of Chicago has added to our country, and the new love and greater pride engendered, because we know it is the product of American genius and American courage. I was greatly tempted in addressing you to-night to do so as "Fellow-citizens," as I once had the honor of residing in your midst and making use of that prerogative so dear to the hearts of Chicago people, and not to make it as warm as did those of your friends who were so unfortunate as to live in a city other than Chicago, and as I resided in your city at the time when one of your largest suburban towns lying west of the Mississippi River, called St. Louis, imagined it was in the race, I lost no opportunity to make you city the burden of my song, and so you see to some extent I am fitted by my early education to perform the purposes for which I came here to-night. St. Louis never has fully forgiven you for the manner in which you have beaten her in that race, and her papers every now and then, referring to your city, spoke of "hogs," "big feet" and "windy city," and it is said, a short time ago, that in one of her Sunday Schools, while a teacher was giving a lesson in which he expatiated upon the wickedness of mankind in general, that all were born in sin. Said a little boy: "Please, Mr. Teacher, I was not born in sin; I was born in Chicago." Said the teacher: "That is worse yet."

I am perfectly willing to admit that a great many good people in New York were seriously disappointed when you succeeded in wresting the great prize of the World's Fair from her; especially after we had decided there was no other place to locate in but New York; but I am not sure but what there were some muttering there about "hogs," "big feet" and "windy city," and when we came here and saw your marvellous creation of the World's Fair and realized all we had lost, and how completely you had outwitted us in the selection of that Fair, a great many of us felt very much like the parrot of the clergyman, which

that this association has reached in its journey, and that a majority of its charter members are alive and well and here to-night to testify to its usefulness, not alone as a business organization, but as a social factor in their lives. When we pass the age of 40 we do not usually make many new friendships, so it behooves us to "grapple to our souls with hooks of steel the friends we have and their adoption tried."

The monthly meetings of our association and our annual banquets lengthen and strengthen the chain of our personal friendships and make life worth living.

But for fear that I may be spiking the guns of some of those who follow, I will now confine myself to my main duty.

Has it not occurred to you that the so-called Toast Master is very greatly handicapped where the names and positions of the speakers are known in advance? Be he never so brilliant in his exordium his every reference is discounted and he is never able to surprise. I must, therefore, leave it to the eloquent speakers themselves to surprise you.

There is one subject that is dear to the hearts of us all, and without which no after-dinner card in this rising village would be complete. We are everyone of us firm believers in Home Rule; in government of ourselves by ourselves in the great future of our municipality. We are immensely and properly proud of its glorious past, and we have no apologies to make for our enthusiasm, though we be called "windy" or "wooley," or told that we citizens of Chicago do not know at exactly what temperature to drink our champagne. We have with us to-night a fellow craftsman from the grand old city of New York, the city whose name and fame were synonymous with America, which stood for everything great and progressive in this republic. This gentleman having acquired his early business education in the great and boundless west, has not had his powers contracted by any "pent up Utica," but he left us many years ago for the Atlantic seaboard, where his western energy and his native ability were quickly discerned, and caused him to be promptly adopted by the "wise men of the east." He will, with his rare gift of expression, tell us how "iters see us." Your banquet committee is under deep and lasting obligations to him for coming directly and especially from New York to speak here this evening. He is in such demand that he must return immediately to address at their annual banquet his fellow members of the New York Jewelers' Board of Trade.

Gentlemen, I have the pleasure to introduce to you Col. J. L. Shepherd of New York, a soldier of the late war, a successful business man and a high officer in the Grand Army of the Republic. (Applause)

John L. Shepherd, president of the Commercial Travelers' Club of New York, made a decided hit with his brilliant remarks. His address was punctuated with applause and laughter at his cleverly told anecdotes, and caused Dr. Lawrence to lean toward President Sackett and remark, "That is the cleverest after-dinner talk I've ever heard." Mr. Shepherd's address follows:

account, no doubt, many of you have heard. This parrot had the bad habit of swearing, much to the disgust of the pious gentleman, and a friend of his said to him: "The next time you hear that parrot swearing, take and throw some water upon it and that will break the parrot of its habit." One evening when the good man was saying his evening devotions the parrot, in a very loud voice, invited all to go to that very certain hot place. The enraged clergyman seized a bucket of water and threw it upon the parrot, and at the same time whirled the cage around rapidly and threw it into the corner of the room. The parrot shook the water from it, and looking up at the clergyman, cried out: "Hallo, pastor, old boy, where in hell, old boy, were you when the cyclone struck us." (Applause.)

The city of Chicago is no less wonderful to the world at large than it is to your own citizens. The fact is well illustrated by a conversation overheard a short time ago in the smoking room of a parlor car running between New York and Chicago, carried on between two traveling men, in which Chicago was the chief topic of conversation, and while one of them was relating some story to the other the first said: "How long since is it that you have been home?" "About two weeks ago," said his friend. "Two weeks," said the first speaker, "my God! you won't know the town when you get back." (Applause.) One of the most remarkable features about the city of Chicago is that it has no past, no history, except that which lives in the minds of its oldest inhabitants. Just think of it, gentlemen, for a moment! A city claiming a population of two million souls whose birth and christening is remembered by thousands of its inhabitants! Truly it is most marvelous and most wonderful! (Applause.) A recent writer in referring to Chicago said that in its rapid march of progress it had overcome many almost insurmountable obstacles, and that in doing so it had not at all times had that consideration for the feelings of its competitors which one expects from a great people or from the people of a great city, is one of fact and not of theory; and in a work of this kind the finer courtesies of life are even lost sight of in the fiercest of conflicts and competition. I do not believe it is a matter of regret that your competitors have been over-lavish in the compliments they have paid your work nor do I believe that meekness is one of your greatest virtues, although a gentleman has said of your city that meekness is one of the chief characteristics of the people of Chicago, and he said that no doubt our Saviour had Chicago in his mind when he said: "Blessed are the meek and lowly for they shall inherit the earth." My faith in your meekness received quite a shock in a story told me by one of your jobbers, who said a short time ago that one of his friends, Mr. O'Toole, either an alderman or a policeman, if he had been in New York he never would have got out here with that name—that Mr. O'Foole was showing his friend Dennis the sights of Chicago. After having gone around for quite a while Dennis said to Pat: "What is the meaning of those words *pro bono publico* that I see on so many of your public institutions?" Pat replied: "I do not know just what they do mean, but a friend of mine down at the Court House said they were French and meant 'To hell with New York.'" (Applause.)



J. F. TALBOT.

Gentlemen, laying aside all these stories about you and your city, I do not believe there is a patriotic man or woman in all this broad country that is not proud of you and your city. Why should we not be? Is it not an American city and the product of American genius? It may be, however, that we are standing too close in the wake of the envy and millstone of competition to measure your work at its true worth; but when the gentle hand of time shall have smoothed away all prejudice, and love and memory shall have made golden all you have accomplished, then from the rocky coast of Maine across this mighty continent, to where the salt spray of the Pacific sparkles on the golden shores of California, will the city of Chicago be the pride and glory of every patriotic man, woman and child that loves American genius and American courage. (Applause.) You may call this flattery, if you will, but these sentiments are truth, and truth is the most sincere flatterer, and I defy any man from any city of the world to stand before you here and tell in language most modest all that you have done and not be accused of flattery. If I am to find fault with you at all, it is because of your selfishness in claiming the sole honor of the public spirit that has caused all these things, for in your every enterprise we see the inherited genius of the sons of the west of the fathers of the east. And I do not believe that there is any dream of greatness that ever blossoms and blooms in your soul that is not perfumed with some loving memory of your old New England home. (Applause.) \* \* \* \*

Who shall find words to speak of your crowning glory, the World's Fair? Truly, not I, for, in its presence, words lose their meaning, and eloquence stands speechless and dumb. All the world doubted your ability to fulfil your promises because they knew you not, and thought that you should fail. Chicago knows not the meaning of that word "fail," and in two years of time there bloomed upon the shores of Lake Michigan that great White City, of whose glory the black man speaks to his doubting comrades amidst the darkest jungles of Africa, and even the yellow children of the east sit palsied in amazement, forgetting the traditions of their departed in the shadow of your work, and amidst the sons of the far north its glory shall live in tradition, among the undeparted Esquimos until time shall be no more. In all the civil nations of the world the World's Fair to-day is an object of honor and of envy. The noble generosity of your citizens has taught the world that America is not alone a nation of money getters, and in building up the commerce of this great city you have not lost sight of the great blessings of the mind and soul. You have acquired wealth that you may make better the world in which we live, to lift up the poor and lowly, and that your children may walk in the higher plane of life, and the noble university into which your citizens have poured their wealth is a promise that Chicago shall be in the field of knowledge what Chicago is to-day in that of commerce, a leader. As I look around me here to-night, I see men associated with every enterprise adding honor and glory to your city, and I do not believe any trade has brought more honor and glory to Chicago than this trade of the jeweler whose gems sparkle with that glory which is so typical of the glory of Chicago.

May I ask you in conclusion that in your quest for wealth that you lose not sight of the fact that you are a part of this most wondrous country, and that the east, west, north and south have all contributed to your glory, and let no narrow minded prejudice or jealousy blind you to the glory of the great eastern city that sits enthroned at the golden harbor of the port of New York. (Applause.) As I entered the gates of your city there seemed to fall upon me above the roar and din of commerce the mingled voices of the people who once came from the familiar scenes of New England, the rustling of the golden corn upon harvest fields and the waving grain upon rolling prairies, the moaning of the trees upon the mountain tops mingled with the perfumes of the roses and magnolias of the south, all blended into one harmonious praise of the city of Chicago, and as the smoke of the destruction of the White City darkened the heavens, we saw in it the incense of your offerings of our country whose proudest boast shall be that theirs was the only nation that ever in the lifetime of one generation caused to blossom and bloom upon the face of the earth, a city of Chicago. (Applause.)

The TOAST-MASTER: "We now come to  
*Some Words on the Currency.*

"What the country wants, and wants quickly, is immediate relief for the Government finances, and we want the aid of the best men of all parties—we care not whether they are Democrats, Republicans or Third Party.

"There is a goodly number of such clear-headed, broad-minded, experienced and patriotic men, who claim Chicago as their home; men to whom the entire country, as well as the executive officers of the General Government, look for assistance and advice in critical financial times, and in the fore front of those stands a gentleman whom we delight to honor, not only for his sterling integrity, his honorable and brilliant record in the world of finance and commerce, but for his never-ceasing activity in philanthropy, in large public affairs and in higher politics. We all know that these are troublous times for both the Government and the citizen, but I firmly believe that the worst is past, and I beg of the gentleman not to think that I am endeavoring to commit him to any special financial policy when I use the Miltonian metaphor that the sable currency cloud is at length showing forth a silver lining.

"Gentlemen, it is in reality superfluous for me to introduce to you our honored guest and fellow-citizen Mr. Lyman J. Gage." (Applause.)

SOME WORDS ON THE CURRENCY BY LYMAN GAGE.

Mr. Chairman, Mr. Toast-Master:—My first duty is to acknowledge your great kindness in the flattering words in which you have introduced me to this audience, words that I am sure I do not at all deserve. It is my next duty, I think, to compliment the programme maker in having that artistic skill which marks the true painter, when behind the glowing figure in the foreground he throws a dark, sombre background. Indeed, one might well be proud to serve as a background to the brilliant oration to which

we have just listened, as delivered by the gentleman from New York. (Applause) I was a little surprised to hear the words of the chairman, quoted as they were by the Toast-Master, that they have taken the pains to write down what they had to say, in order that they might be properly reported by the press. The only trouble I have ever got myself into was when I was properly reported, (laughter) and I never know, when I expect to speak in public, whether to prepare a manuscript and take the risk of being properly reported, or to speak without manuscript and take the risk of either being improperly reported or not reported at all. I heard a gentleman once say that there were two occasions only on which he would ever take a drink; one, he said, was when he was alone, and the other was when he was with somebody else. (Laughter.)

I am sure there are two occasions when I feel a sense of numbness, conceal it as I may, and I tremble at the knees, stand as firmly as I can; here are two occasions when I have this feeling that I have described. One is when I have a manuscript to read from, and the other is when I have to speak without a manuscript. In the first case I am always afraid my audience will peter out and in the second place I am always afraid I will peter out myself. (Laughter.) I have envied these other speakers who have these subjects allotted to them where poetry and eloquence will well adorn what they utter, but who can be at all eloquent or give the faintest suspicion of eloquence for the theme so plain and practical as the one announced, some words about currency.

It does seem a pity to intrude on an array of festivity like this a theme like this. It is about like bringing business into hours of conviviality. Words of cheer, encouragement, happiness, song, fancy—those are the words for such an occasion. And yet it seems to be excusable, indeed I think it is for men whose interests are so much concerned in our national life and our business affairs as all of you are, to take a little section of time—and I agree not to take a very large section—for some serious thoughts that may furnish food for reflection and mutual consultation afterwards. We have come indeed to a peculiar situation. A country, the richest in the world in all of the resources that lie at the command of man and industry whether under the soil or on the soil, whether of grain and forest, or the treasures under the soil, no country on earth can compare with this; a population so vigorous and hardy and daring that it penetrates all climates; mountains can not intimidate or restrain it; the deserts are made to blossom. How did it come about that with a country like this and with a population like this we should find the representatives, the focalized representatives of all the people in the government, in the condition of semi-bankruptcy? What witchery has come over us?

At our situation the whole world looks on with astonishment; they cannot believe it possible that the United States of America can be capable of so weak an administration in all those affairs which make government credit and individual credit as that which they now witness at Washington. This thing, I think, is the result largely of discordant voices falling upon the ears of those who represent the people. We have



H. F. HAHN.

learned to achieve wonderful conquests over nature, the telephone enables us to talk a thousand miles; the cable helps us to transmit our thoughts over the Atlantic in a few seconds of time; the triple expansion engine accomplishes wonders; the Edison phonograph, and all these modern conquests over nature, seem to have bewitched us with the ideas that all the laws of nature, of every kind, can either be superseded or turned against themselves, if not in morals—some believe that they can be in morals—then in business and in finances; and so we see springing up on all sides the most astonishing vagaries relating to money.

There is published in Kansas a paper. I forget the name of it, I was honored with the receipt of a copy the other day, in which they advocate indirect issue by the government of paper money at the rate of two per cent. per annum to the full value of all the real estate property owned by any one who will make the application to the proper agent of the government to get it. (Laughter.) Perhaps that is not exactly the words. A short time ago a very honest man, dressed like a gentleman, came into my office and said, "Have you seen my book?" I said "No, I haven't seen your book." He handed me a little book of about sixteen pages and said, I wish you would take that home with you and read it over to-night, and tell me to-morrow what you think of it." I took it home and read it. He wanted to get up a society of some thousands of persons; I think the membership fee was \$2 each; and they were to move on Washington and secure an issue from the government of \$12,000 per capita of paper money for all the people of the United States. The members of that particular society were to have as a consideration for their contribution of \$2, and their influence in securing the bill, \$4,000 each, as their premium on the undertaking. (Laughter.) He came in the next day and asked me if I had read it; I said, "I have read it, every word." "Well," said he, "what do you think about it?" "Well," I said, "there are some ideas in there (laughter), but your hairs and mine are gray and I am afraid you are too advanced for this generation; I don't believe you will live to realize it." "Well," he says, "that is the only thing I am afraid of." (Laughter.) "By the way," he says, "do you know how I could manage to get a pass from here to Washington Territory?" (Laughter.) I said, "I do not; I never apply for one myself—I don't know the *modus operandi*." He said, "I live in Washington, and I want to go out there, and I am broke." I says, "How did you get broke?" He said, "Peddling my book." He continued, "I have a wife out there, and we had a farm. We sold it and divided the money. She has her half now, but I have sunk mine in promoting my idea." I said, "Where are you stopping?" "Out here at Dunning." (Laughter.) I said, "Do you think that I would advance you the money?" He said, "I didn't know but you would." "No," said I. "I guess your security is a little thin. You have got your scheme and you have sunk your own money, and that is all you have as collateral, is it?" He said it was. He was a very honest man. I really felt sorry for him. He wrote a letter to his wife, and in due time she wrote him back, putting money in the bank somewhere over in Washington State, and in her letter to him she said, "Now, you take this \$30. I give it to you as the last. You have

trenched on my share of the farm once or twice. You take this \$30 and come home, but you can chase your vagaries alone after that, you will get no more out of my share." I had lent the old man a dollar the day before, and he paid it back out of that draft, so I know he is honest.

Now, there are thousands of men in the United States just as honest, but they believe that a science as recondite as chemistry can be achieved out of the inner consciousness of a man that don't know anything about it, (laughter) and that their opinion is as good as anybody's on earth. They intimidate the representatives in Washington. We see the government with \$350,000,000 of demand liabilities, with a revenue insufficient to pay its current daily expenses. It hasn't the courage, the foresight or sense to do the thing that the simplest man in the United States would do if he was in the same situation. They have borrowed some money, as you know. Within a year they borrowed a hundred millions, and they are as poor in their cash resources as they were a year ago. The foreign demand for gold comes at an unfortunate time—our sins always take us at an unfortunate time. It comes at an unfortunate time, when the government revenues are insufficient to pay the current expenses. They sell the bonds to get the gold to redeem the notes, pay the notes out again for expenses; the notes are presented for redemption; sell more bonds, issue more notes and pay them out for expenses and so the circuit of exhaustion goes on. They remind of the farmer who said he had a phenomenon; he said he had a pig that he would feed a pail of milk to, and then he could take the pig and all and put him in the pail, and he would only two-thirds fill it. (Laughter.) He couldn't understand that. Perhaps better than that was the butcher who had a cat; the cat grew thin, meager, gaunt and hungry looking. He said to his Irish servant: "That cat looks bad: do you feed her?" Pat said: "I do feed her, sir." "Well, feed her more." "How much shall I give her?" said Pat. "Give her a pound of meat a day." "All right, sir." Three or four days after that the butcher noticed that the cat was as thin and gaunt as ever. "Do you feed that cat, Pat?" "I do, sir." "Do you give her a pound of meat a day?" "I do, sir." "Did you give her a pound of meat to day?" "I did sir, about half an hour ago." He says: "Come here," and he put her in the scale and she weighed just a pound. He says: "Yes, the meat is all right, where the devil is the cat?" (Laughter.) Of course you have all read—and that is one of the troubles of it, you hear so much about it, so many communications in the newspaper about it, so much speechmaking about it, so many bills reported about it that we get tired reading about it and give the whole thing up as hopeless, pretty near.

But you have heard of the "Baltimore Plan," which is a bankers' plan adopted by a sort of town meeting vote, and canvassed one by one, when they were all opposed to it. You have heard of the "Carlisle Plan," which is a patent right to take away the security from all banks and allow all banks to issue their notes provided they would take 70 per cent. of the notes of this poor government which is unable to pay its own, and deposit it as security for \$100 of their own notes.

This scheme of Carlisle's was a politician's scheme. By it he was enabled to say to the inflationist, "You ought to vote for this, because for every \$30 taken in there will be \$100 put out: you are in favor of inflation." He would say to everyone who considered it a holy horror a sin to pay reasonable interest, who consider it a sin for the government to fund these demand obligations which they are unable to pay, into interest bearing obligations. Here is a trick, you see, by which we can make the bankers carry the obligations of the United States which we have not the integrity and ability to protect ourselves. (Applause) Now it seems to me there is a simple way for the government to get out of this business and let the thing all fall where it ought to fall. There are, as you know, \$150,000,000 and \$346,000,000, make \$496,000,000 of the demand obligations of the United States Government outstanding.

The Government has on hand now, either in gold or partly retired, that if it has not yet paid out, very soon may have \$100,000,000 of gold or its obligations, leaving outstanding unprotected by gold, \$396,000,000. If the Government of the United States would offer a loan, drawing interest at 2½ per cent., and allow the National Banks to take at par and put them up as security for their circulating notes at par, and reduce the present outrageous attacks on bank circulation, which is one-eighth to one-quarter per cent. All these bonds, to the amount of \$250,000,000, if not taken by the public would be taken by the banks and made the basis for their circulation medium—namely, National Bank notes.

That \$250,000,000 to \$300,000,000, thus funded for Government notes, thus replaced by National Bank notes, the problem of the Government as relating to currency and redemption would be completely, absolutely solved, because the notes for reserve by the bank of the United States and by the increased notes for reserves, owing to the issue of these \$250,000,000 of their notes by the banks of the United States, would absorb into their vaults, as reserve, sufficient of the then outstanding volume of the currency to enable Mr. Secretary Carlisle to go to sleep and concern himself no more about the redemption of the Government notes. Now, every business interest in the United States stands paralyzed—partially, not wholly so, I am thankful to say. In spite of all these untoward influences at Washington, in spite of the shadow which hangs over us there, the natural ability of the American people, their natural enterprise, is operating to pull industries and enterprise and trade and commerce together; and that man is dull indeed he does not see sympathetically, even if he cannot demonstrate it, a steady, uprising pressure from below, for we have trade, we have industry, we have employment, we have profits; in short, we have commercial life in all its aspects, and all we need for this movement to go on sharp and effectively is to have this problem of the currency solved at Washington. I will not take your time longer; all I will add is this, that if you have any influence anywhere among those who represent the people at Washington, urge them to look at this question purely from the government standpoint, and protect their own credit, fund their own obligation, get themselves out of the way of being a menace and a threat to our industry, and with the industry of all the people of the United States

# COSTS AND VALUES TOTALLY IGNORED!

RARE OPPORTUNITY TO BUY HIGH QUALITY WATCHES AT LOW QUALITY PRICES.

Prices Net Cash.—16-Size, 3-4 Plate, Hunting and Open Face, Stem-Wind.



20 finest quality red ruby jewels in gold settings, jeweled center, full cap jeweled escapement, Breguet hair-spring, accurately adjusted to temperature, isochronism and all positions, micrometer regulator, double sunk dial, finely damaskeened and finished throughout.

No. 71. Nickel Hunting and Open Face..... \$50.00



18 fine ruby jewels in gold settings, center jeweled, cap jeweled escape wheel, Breguet hair-spring, accurately adjusted to temperature, isochronism and six positions, micrometer regulator, double sunk dial.

No. 72. Nickel..... \$35.00



16 ruby jewels in gold settings, jeweled center, Breguet hair-spring, adjusted to temperature, isochronism and four positions, micrometer regulator.

No. 73. Nickel, Hunting and Open Face.... \$25.00

15 ruby jewels in settings, Breguet hair-spring, adjusted to temperature, isochronism and three positions, micrometer regulator.

No. 74. Nickel, Hunting and Open Face.... \$18.00

SEE REDUCED PRICES OF COMPLETE WATCHES.



K 30—14 K. FILLED, 16S. HTG. GUARANTEED FOR 20 YEARS.

COMPLETE WITH:

	REG. PRICES.	CUT PRICES.
No. 71 Movement.....	\$60.00	\$34.00
" 72 " .....	45.00	26.50
" 73 " .....	35.00	21.50
" 74 " .....	28.00	18.50

K 31—10 K. FILLED, 16S. HTG. GUARANTEED FOR 20 YEARS.

COMPLETE WITH:

	REG. PRICE.	CUT PRICE.
No. 71 Movement.....	\$58.00	\$32.20
" 72 " .....	43.00	24.70
" 73 " .....	33.00	19.70
" 74 " .....	26.00	16.70

K 32—10 K. FILLED, SCREW BEZEL AND BACK. GUARANTEED FOR 15 YEARS.

COMPLETE WITH:

	REG. PRICE.	CUT PRICE.
No. 71 Movement.....	\$54.00	\$28.60
" 72 " .....	39.00	21.10
" 73 " .....	29.00	16.10
" 74 " .....	22.00	13.10

THESE movements which we offer at special reduced prices as complete watches were closed out to us at a sacrifice price on account of being engraved GENEVA NON-MAGNETIC WATCH CO. At the low prices we offer them as Complete Watches they are a bargain. Beautiful in finish, accurate in performance and absolutely non-magnetic, they offer at our reduced prices more value for the money than any watch made. With the growth of the uses of electricity the requirements for Non-Magnetic Watches increases and opens a new field for watch dealers. As we have all there are of the above described movements, the prices and grades of which are unknown to your customers, they will PAY GOOD PROFITS.

Don't miss this opportunity but send us your orders at once.

## A. C. BECKEN, The Chicago Wholesale Jeweler,

103 STATE STREET, CHICAGO.

SPECIAL AGENT FOR DUEBER-HAMPDEN WATCHES. SEND FOR LATEST POCKET PRICE LIST,

N. B.—Paillard Non-Magnetic movements engraved "Non-Magnetic Watch Co. of America." we can only sell at regular established prices as per list at top of page.

# GOODS WELL BOUGHT ARE HALF SOLD.

We, perhaps, cannot expect much for this Congress, but the thing we can hope for and agitate for and speak for and beg for, is the appointment of a commission properly organized, who, during the vacation, will take up this scientific study, analyze and neutralize all these so-called arguments of cranks and advocates, and show the people, as a whole, and those that represent them hereafter, the true law of currency and the true way to find deliverance from the evils which have so long threatened us. (Applause.)

Mr. Gage's speech was such as might have been expected from so great a leader in finance, and was interspersed with flashes of humor that were as appropriate as they were unexpected.

#### THE TOASTMASTER:

"I am very sorry to have to announce to you that Dr. Hirsch is prevented from being heard by you all here to-night. I am doubly sorry because of a very severe illness of his little son, and I know I am voicing the sentiments of you when I send him a message of sympathy and condolence with the hope that his little boy will soon be quite well again.

#### *The Growth of Ethics in Business.*

"I have very high authority for the statement that in the early days of Chicago the amenities of life among competitors in business were not observed with that punctiliousness that distinguished the commander of the French King's body guard at the battle of Fontenoy, who exposed his bosom and invited the English officer to fire first. On the contrary, it was a case of "first come, first served, and the devil take the hindmost." This, of course, carried with it, sometimes very bitter animosities and it changed competitors into *rivals* with all that the word implies. I refer not to the jewelry trade necessarily but to many others as well, not excluding the music business, that very humble but necessary handmaid of the Art Divine. Their touch (with each other) was not always harmonious, nor was their tune melodious, when describing the piano of the other fellow. But the world moves onward, if slowly, and such conditions are, in great part, past and gone, and we have such bodies as the Chicago Jewelers' Association to thank for it—long may it live and prosper.

"Ethics is defined by Webster as 'The science of human duty,' and the mission of such associations is to teach their members how to apply those rules in their daily business intercourse. We are honored to-night by the presence of a member of our judiciary whose name and fame stand for all that is embodied in Shakespeare's short but comprehensive line, 'An upright judge, a learned judge.' He especially represents the younger generation on the bench, but in a manner most fully approved by every generation, while the esteem in which he is held by the people of Cook County was attested by his triumphant election at a time when the other candidates of his party and of the party of a few more of us met defeat.

"From the very nature of his high office he is most deeply versed in this 'science of human duty,' and I call him to speak some thoughts thereon. Gentlemen, I have the pleasure of introducing to you that able jurist and sterling Democrat, Judge John Barton Payne."

ADDRESS OF HON. JOHN BARTON PAYNE.

#### *Toastmaster and Gentlemen:*

I have reached the conclusion that I am a find. A f-i-n-d. A little more than a year ago, the last time I had the pleasure of being in this location I happened to be the guest of the Fellowship Club, and I was introduced as the only Democrat then living; it had been said that I had survived the wreck. We do not feel that way; brother Byrne and I are still on deck. You have asked me to discuss the subject: "The Ethics of Business." I have listened with great pleasure to the modest claim of Chicago so admirably set forth by our brother of New York, but the modesty of Chicago is very far exceeded by the modesty of this association. I am told that you are now celebrating your 18th anniversary. It is not the fact at all. We have heard a distinguished member of the banker's profession here making some suggestions on currency. Do you know that the distinguished lineage

of the jeweler, of the goldsmith and the silversmith, reaches far back into remote times, antedates all banks and all bankers; that the real banks of all the peoples of the earth, and that the people to whom the English Government was wont to go when it desired money for the purpose of defensive or aggressive war, were the gold and silversmiths of London. Your association, then, has the right of lineage beyond that of any profession, occupation or business which sits around this festive board. Being the oldest, it has the right to stand for more—it has more history to be proud of, more achievements to be nailed upon its banner. It has a right to stand in this community for



A. L. SERCOMB, EX-PRESIDENT.

the ethics of business. What are ethics? The giving intrinsic daily honesty. An honest man is a good man; a good-hearted man; a man who has instincts simple and upright—who is ready to stand in a community for the right, individual, government, public—and that is what we need in this community. See the old houses of the country. Their simple name upon any article of merchandise means integrity. That integrity is based upon character; that character is based upon homely honesty, and if these three concur, all the world stands emblazoned in truth, and ethics come as a matter of common right. In this community we have had reforms of all all sorts and conditions. We need them; we need more than that. Reforms cannot possibly succeed unless there is at the basis individual integrity; you must have that in your business before you can have anything like success; you must have it in your community before you can have public honesty—individual honesty. If you have individual honesty you have business ethics; you have public administration which is the admiration of all the world. The Jewelers' Association then is not new, either in its principles, its professions or its practices, because it stands in this community for high dealing, for honest purpose, and the success of this association evidences that fact because without it your Association could not succeed. Your purposes must fail unless based on these homely principles. I say then that business ethics have succeeded beyond our fairest expectation, because in this city the business men have given to it its character in its own community and among all the peoples of the earth. In the matter of government we have to get a government as we are entitled to have. I say that advisedly, and in business we have as good business men, as honest, as intelligent and as aggressive as the people will permit. Chicago has made her reputation because of the aggressiveness of her business men. We have achieved wealth, distinction, success. It is time now for us to look at some other question, some other proposition which confronts us, and that is, it is time to adhere to the simple principles which I have suggested to your consideration, and which

have made this Association a success. You are now, in fact, passing your 18th milestone. You can look back at the time when the spirit which now pervades the Association did not exist. You have come together as friends, you learned to know the value of each member of this Association, you looked upon him not as a rival, but as a brother, as a man who has character, and who stands in this community for the right, and whose place is made because of his intrinsic worth. Did it ever occur to you what friendship means in this Association? In this busy aggressive life of our we have no time for friendship in the sense in which that term is used. We have spent our lives making business a success. In the country each man has around himself five to ten men who will stand by him through evil and good report, who will sustain him if he fall, who will stand by him in success, and in failure will reach him the strong hand of individual fellowship and friendship. In the great cities there is not time for that sort of friendship, but it must come from this association. Here you know each other, and the man whose character does not bear examination, who does not bear that brotherly strength, must go down. The man who does merit that consideration is known to you. He stands by the reputation he has made, and your association has its character made for it by those aggressive, honest characters who have made the reputation of the association and will make that of this city. I beg of you to stop and reflect upon these sentiments. I have no time, nor would I take your time to discuss this question, but simply to ask you to think of these questions and let every man stand upon his individual worth, because the association stands for the concensus of the strong, the honest and the aggressive men who make up this association. Gentlemen, I am glad to be here, and I am sorry I cannot remain longer. (Applause.)

(The quartette here sang "My Country 'tis of Thee," the banqueters all joining.)

#### *The New Woman.*

#### TOASTMASTER.

"Our next speaker and his subject I feel both delighted and honored to present to you. His high profession and his reputation command our most respectful regard; his subject we greet with chivalrous devotion. To the new woman, what'er her phase, all hail—'Age cannot wither her nor custom stale her infinite variety.' We could not wish her a more graceful apologist, a more able Tertullian than the Reverend Dr. Lawrence, whom I deem it a distinction to present to you."

ADDRESS BY REV. DR. WILLIAM M. LAWRENCE.

*Mr. President, Toastmaster and Gentlemen:*—If these gentlemen who have expressed themselves to the effect that they put themselves in writing in view of their being apprehensive of the reporter, just think of me tomorrow morning, for I will guarantee that if it is said that anybody has anything to say about a woman, it will be read, and I am exceedingly glad that it is the new woman and not the old woman that I am to speak about. (Laughter.) I would not have anything to say if it were the old woman because there is not any old woman in Chicago or anywhere else. It is like the boy who was met by another while he was eating an apple, and who looked on the act with great eagerness, and asked for the to the apple. He responded, "There aint going to be no core to this 'ere apple." (Laughter.) I should have liked if the eloquent speaker from the city I had the honor to have my business apprenticeship, had remained long enough to have had the new woman make her humble courtesy to the eloquent representative of her grandfather, Old Knickerhocker of New York, but he has gone, and so the new woman must for once be silent. I wonder that she can be. (Laughter.)

Now, this new woman in vulgar parlance, is not to be sneezed at, she is here, and like most women, she is here to stay. She is here for a purpose; she used to be used as a convenience. When men came to borrow money of Mr. Gage, he would probably find upon investigation that the house was in some one else's name, which reminds me of the story I heard the other day, and I suppose you will allow me to relate it. A man said: "Did you hear that story about Mr. Rosenthal down town? No. He has got religion. Got religion? Yes. Where has he got it? Why, he has got it in his soul, of course." "Now," he says, "See here, you can just get

**GOLDSMITH BROS.**

**REFINERS**

63-65 **W**ASHINGTON STREET,  
**CHICAGO.**

Lead all Others

ACCURATE VALUATIONS

YOU GET FULL VALUE

RELIABILITY

**SELL GOLD**

**BUY OLD GOLD**

Buy Sweepings

**PROMPT RETURNS**

**GIVE ESTIMATES  
WITHOUT MELTING**

**SEND TRIAL SHIPMENT**

If Estimate is not satisfactory we will  
return consignment intact and pay all  
charges.

**SELL SILVER**

your life if Rosenthal has got religion he has got it in his wife's name." (Laughter and Applause.) I was telling my friend, Mr. Gage, how my father yanked me out of college and put me to hoisting flour barre's in the mill, and how when I got through he told me I could go and do what I pleased after that, and that if I did fail as a minister I might know how to earn my living. I told him how I used to go and collect debts down in New Jersey. Talk about New Jersey justice. There is a lot of it down there. It was sometimes very hard work to find out who was the chief of the concern, and there was a good deal of honoring the female sex in that spirit, and in that sort of way in those days, but that is not the New Woman.

The new woman is a typewriter in our offices. What would we do if it were not for that sweet-faced object of our admiration? How influential she has become! And what effect upon our habits of regularity in departure from our homes in the morning! So strikingly observed by those at home! (Applause.) I ride a bicycle and the other day I was going to Garfield Park, and I saw an object ahead of me. I did not know what it was. It had a hat on and knickerbockers. I soon discovered it was a woman riding on man's bicycle, and 50 feet ahead there was a man riding a woman's bicycle. I said to myself, "I am sober but things look somewhat mixed up there." I speak no more about a woman than any other man, but I think others are just as interested in the woman as the ministers are. The only difference is, if we take any special interest in them, it is known, and if you take such interest in them you will leave it to be found out. (Laughter.)

We do woman great injustice when we suppose that her present position is because of any special endowment of Nature, which has never been recognized. The University of Bologna a thousand years ago celebrated its annual commencement in the great Cathedral of Bologna, the University conferred upon a woman, who was so beautiful, when she taught her class, it was necessary for her to appear with a veiled face, the degree of L.L.D., long before the present professor of Greek at Vassar College knocked at the doors of Professor Sophocles and demanded to be instructed in Greek. The advance of Woman to-day is only a Renaissance. There has come into her history a period of depression. She is only climbing back again where she was some years ago, with this advance modified by the demands of the time upon her. Now she has come as a factor. We sometimes think that the only thing that a woman can do is to ornament us. Now the new woman has come to take her place, and she has come to make the young man prove that there is something more in this world than beaux for our girls or chaperons, if I may borrow a French term for those who are a little passe. I see she has come to make the young man prove his manhood, and I am inclined to think that she will put her big sleeves right over his head and put him out of sight.

I happen to have some functions to perform in connection with the Chicago University, and I said to its honored president the other day: "Tell me what the effect of Young Womanhood is in this institution?" He replied: "The effect is that when a young man stands alongside of the young woman to recite, brain is measured with brain, keenness with keenness, logic with logic, effectiveness with effectiveness. What is the trouble to-day with many of our young men? I have more or less experience trying to get young men situations, and they come and say to me, "We can do anything," and when I come to look into the matter, I find they cannot do a thing." When a young girl comes around, you ask her, "What can you do, Madame?" She will say: "I can do so and so;" not that I can do anything (which generally means I can do nothing). She is clear, explicit, definite, practical, ascertainable, valuable, and I have no difficulty in getting young women positions alongside of young men. But after all, is there anything which a man ever does well in which he is not joined by a woman?

What under heavens would you jewelers do if it were not for a woman? (Laughter.) They wear your diamonds, your sapphires and your rubies; they are on the keen scent for the latest designs in silver and goldsmith ware. It is their taste which is incarnated in the advances which you make. One of the most useful books I ever read in my life was the Biography of Benvenuto Turini, that wonderful silversmith, and the remark of the honorable Gentleman made absolute history when he said that the profession which you are identified with is the

foremost profession in the world along the line of the artist; and when I read that book and noticed the narration of his great genius along the line of silversmith designing, I could not help but notice the account that the finest bit of cutting in stone that ever was done was done by a woman's hand. This new woman is here. She goes into our telegraph office and she takes our messages and does it accurately, and this new woman is going to exercise an influence upon our country.

There have been some very marvellous essays put forth of late. One I have in mind at this moment is that of a Mr. Eugene Field in which he speaks about the influence of his grandmother upon him; by a bard in which he speaks of the influence of his wife, and another by Canon Farrar in which he speaks of the influence of his mother. We are sometimes confronted with the assertion that the new woman is going to be less the wife and mother to posterity and less the guide and counsellor, but I say No. The new woman claiming the rights which God has bestowed upon her, never will abandon or abdicate that position. God has qualified her in making her a helpmeet to us, and the advice of woman means the elevation of man. (Applause.)

Gentlemen of this association, this new woman is more than the polite toast to the absent one whom we love as Mother, whom we revere as Wife, whom we greet as Companion; it is the tribute of every true man to the true woman. God bless her. (Great Applause.)

### *College Men in Business.*

#### TOASTMASTER:

"The last subject was the 'New Woman,' and immediately following her is the College Man. It is a way those college men have, aye and other men, too, of invariably following the women, God bless 'em. Our friend, Mr. Gratty, gladly joins the procession, and for the sake of the pleasant company will forgive us for placing him last on the list, and we do so with no fear of his being embarrassed by having his thunder stolen like our post-prandial orator before referred to, as we well know Mr. Gratty's supply of thunder is well-nigh inexhaustible.

"Your Committee knowing that there are many anxious parents in this Association, is happy to have secured a disinterested party—a bachelor—to give us his views on how to educate our sons, literally born with silver spoons in their mouths. The proverbial ability of bachelors in managing wives and children (other men's) leads us to hope for valuable guidance and many wise suggestions in our friend's discourse. I would beg to remind our learned guest that while some men are born great, and some achieve greatness, some are born in the jewelry business—shall those uncut, unpolished gems be college cut and college polished? And if his answer is yes, then how well will they fulfill their parent's expectations; how well will they perpetuate the business that has been unbuilded for them by their father's ability and perseverance?

"For a most able solution of the problem I refer you with confidence, to one whom you all know and wish to hear—Hon. T. Cratty."

#### ADDRESS BY HON. THOMAS CRATTY.

*Mr. Toast-Master and Gentlemen:*—The speech of Brother Lawrence was so good and the song that followed it was so sweet, "Good night, Ladies;" we generally quit when we say that, that I wanted to quit; but it comes only once a year, and although it is late, if you can wait only just a little while I will try not to be tedious. A great many successful business men in the jewelry business, as in any other business, perhaps, did not go through a college. Now, I am not afraid of the reporters; I don't care a nickel. I am not the President of a bank nor a minister nor the boss of a committee nor a candidate nor the son of a candidate and I never expect to be. It is a splendid condition to be in. Being an honest man, working for a living, making it, I don't care a cent. I have some ideas upon this subject. I learned them from reading. My father wasn't a business man, and I have no children to be business men, and I never expect to have any (Laughter.) I am proof against either an old woman or a young woman. Artemus Ward was once assigned to speak on music, and he said, "I am saddest when I

sing, but I am not so sad as those who hear me." There is a man in Boston by the name of Delant, who advertises on his cards to give business counsel. He is not engaged in business of any kind, yet he makes a good income by advising business men about their business. He knows how, no doubt. I am not a cultured professor, nor am I a business man.

I suppose you will know without the saying, that a good collegiate education is a good thing, and I suppose it is even more true that wherever it can be afforded and wherever it can be received it ought to be so. It takes many years to put a man through college, and it takes years and pains to go through and get any good out of it. I suppose it goes without saying that a good collegiate education tends to make a man a gentleman. It gives him that eloquence or language, that perfection of diction, that duty of words that helps the business man. Other things being equal, we like best the man who talks to us in good language. What a difference between the polite and amiable clerk in your store who increases your business and the boor who drives trade away. The young man who uses nice language and is always a gentleman, which sometimes comes from a literary education, gets you customers instead of driving them away. I take it to be a good thing in the prosperous man; it gives him a feeling of enjoyment with books, with literature, with the sciences, in his intercourse with his neighbors and friends. It helps him very much in adversity; it helps when trouble and misfortune come. He can have that consolation, that relaxation, that relief, which the ignorant man may not have.

But, if I should say tonight that a college education is indispensable to a good business man it would be unfair and it would not be right; it would do violence to my own judgment and conscience, and it would not be fair to a great many here who were not fitted just as exactly in that way. Some of you have been unfortunate enough to surround yourselves with a lot of wives and children. (Laughter.) You have families to clothe and feed, and you have not the money nor the time now to go to college. Some of you have got into business, and all you have is invested. Some of you, perhaps, are not rich enough, if you had the chance, to go to college, and I am not going to undertake to tell you that you have got no sense without going to college, and that you cannot succeed in business without a college education.

The fact of the matter is that education does not make a business man. As is said of a man or a woman clothes do not make them, but when they are made perhaps they look a little better with clothes on. (Laughter.) In 1880 I heard Prof. Swing preach a sermon—don't think it was the only one I have heard—and it was about the endowment of colleges for educating young men for the ministry, and he advocated that there should be first established an inquisition to inquire as to whether the young men who were trying to get into college were fit to be in the ministry. He said that they were all the time learning tricks, and they come out with a sober face, with a solemn countenance, which is exactly adapted to co-operate with the inner man and swindle people. (Laughter.)

He said that some people think that Pharaoh's daughter finding Moses in the bullrushes made him a Moses. The poor fools! Don't they know that he was a Moses long before he got stuck in the mud? (Laughter.) It is the timber that a man is made of that makes him a merchant or a banker or a professor, or anything else. It is the timber that God puts in him in his mother's womb. It is that that comes from his mother in his mother's milk that is in him when he is born.

They say poets are born, not made. It is true, and it is true that business men are born, not made. These men would have been business men if they had never learned a single syllable in school, having an education helps them; it helps them to talk in public; they can use fine language, language that can illustrate; and they can make it ornate and elegant and all that, but it doesn't make a business man simply to educate him in a school. You can't make a man cut out for a minister a merchant, nor a man cut out for a merchant a minister. You can't make a bad man good by sending him to school. Good men are good because they are good. It is in them and has to come out. These business men are business men because they are made of that kind of stuff. They got it with their birth. Business men are business men because they are made that way. Gentlemen, you have it in your own hands,

# THE EMPIRE PATTERN.

NEW DESIGNS FOR 1895

TRADE  
MARK.

## 1847 ROGERS BROS.



MANUFACTURED BY

# THE MERIDEN BRITANNIA CO.,

New York. Chicago, *MERIDEN, CONN.* San Francisco, Hamilton, Ont.

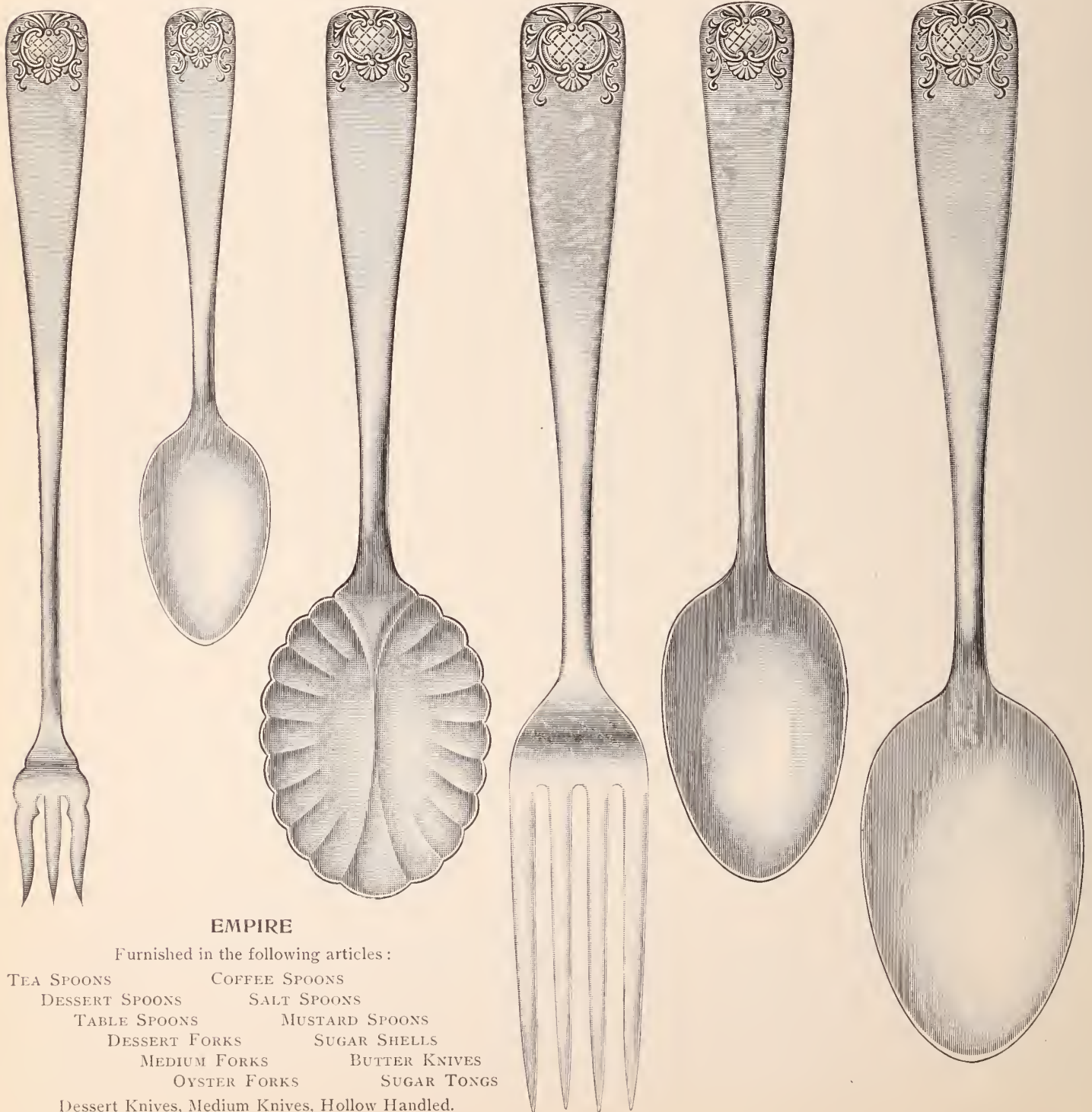

### EMPIRE

Furnished in the following articles :

- TEA SPOONS                      COFFEE SPOONS
- DESSERT SPOONS              SALT SPOONS
- TABLE SPOONS                  MUSTARD SPOONS
- DESSERT FORKS                SUGAR SHELLS
- MEDIUM FORKS                BUTTER KNIVES
- OYSTER FORKS                 SUGAR TONGS

Dessert Knives, Medium Knives, Hollow Handled.



The business men of this country are the sinew and the brain of the nation. They make it and they sustain it, in the true sense. The miner digs the metal out of the earth, the gold, the silver, the copper, the tin, but it is mere dead weight. When men coin it into shining dollars, it does nothing, it is no good until the business man gets it into his hands and manipulates it. Then it produces; then it gets into the business world and becomes a power. The business man makes the money, makes the world, makes and sustains the Government. He produces the money that supports the families and that supports the Government; that builds the school-houses, the factories and the great marts of trade, the ships and the trains of cars. He builds them; that is his work. Of course intelligence is important, but although you cannot cypher in the calculus, although you cannot figure in algebra and trigonometry, although you cannot read the dead languages, you can mark, if need be, on the cellar door the cost and price; you can figure with your neighbor; you can follow the markets to perfection; you can scalp your neighbor in a trade like a Comanche Indian, and it doesn't make any difference whether you have been through college or not, you can do it. It is the timber that makes the business man. Work to the point, and my word for it, sooner or later you will find yourself successful, whether in the jewelry business or not. (Applause.)

THE TOASTMASTER:—"We skip one toast to-night, but I think we ought to make up for it by calling on a gentleman whom you all know. He has recently been adopted into the jewelry business; and I therefore ask Mr. Henry J. Furber to address this association for a moment."

#### SPEECH OF HENRY J. FURBER.

Mr. President and Gentlemen:—I regret that I have been called so late in the evening. An hour ago, I should have attempted to be funny, but the sobering influences of speeches to which we have listened for the last hour has made it absolutely ridiculous for me to think of being funny; particularly when I consider my surroundings. Here I am an old man surrounded by my grown-up boys, who would at least be sixty days poking fun at papa for trying to be funny on this occasion. It remains only for me to sum up as the last lawyer who is permitted to speak in the case, the substance of those who have gone before me. In the first place we listened to a most eloquent address of the gentleman from New York, on the City of New York. Now, imagine the gentleman from New York telling us anything about Chicago, and particularly the jewelers of Chicago. Why, gentlemen, I would stake my salvation on a stack of monthlies—mean Bibles—that there is not a man in Chicago; that there is not a man in New York, who has any comprehension of the advantages of being a citizen of Chicago as compared with the jewelers of Chicago. We have listened to the distinguished gentleman, a citizen of whom we are all proud, on the subject of "National Currency." Is there anybody who has a keener appreciation and prizes more highly the national reputation than a jeweler of Chicago to-day? We did not listen to Dr. Hirsch, who was scheduled to speak to us to-night on "Civic Virtues of Chicago" and elsewhere.

We come next to the "Ethics of Business." We have listened to the very eloquent address of the Honorable John Barton Payne. I dare venture the assertion that the Honorable John Barton Payne nor any other person has a keener appreciation of what belongs to business—right and wrong—than the jewelers of Chicago to-day. The New Woman and the Old Woman. While the jewelers of Chicago still admit they have a keen appreciation of the women not only of Chicago but elsewhere, still, as far as respect for the virtue of woman, old and young, is concerned, the jewelers of Chicago stand ahead of all other businesses. Man is business. If there is a field open wide and attractive to young men to enter upon a business career whose integrity is fixed, whose purpose and intention is honorable and straightforward, we feel that the jewelers of Chicago open a wider field than any of them. I can say this for my association, that many of the prominent jewelers of Chicago, in daily intercourse with them, and I say to the young men of Chicago, who enter upon a business career, who are well grounded and honest and faithful in intention, that the jewelry business of Chicago opens a wider field than any other business of to-day.

I say this after years of association with the gentlemen surrounding me here to-night, many of whom I know intimately, and I say the business enterprises of the City of Chicago to-day, of all of them, none are more fully known, none are crowded with men of more integrity than the jewelry business of Chicago to-day. (Applause.)

THE TOASTMASTER:—"I now declare the Eighteenth Annual Banquet of the Chicago Jewelers' Association ended."

And thus closed the jewelers' gala night.

#### Echoes of the Banquet.

Attendance—145.

H. M. Burchard was in his element.

We missed the Muhr brothers—Simon and Jake.

Judge Oliver H. Horton gave dignity to the Meriden Britannia party.

M. A. Mead is visiting his family in Colorado and was necessarily absent.

Benj. Allen was missed. The marriage of his daughter, Miss Bessie Allen, prevented his attendance.

Those youngsters, Dripps and Cox, were again to the fore in representing the house of Benj. Allen & Co.

Pretty good people in that Reed & Barton group, Harry Lane, C. D. Peacock and Clayton B. Shourds.

George Gubbins has changed houses, but got there just the same. It was a great team, Payson, Gubbins and Smith.

Just an even 10 marked the number representing the Elgin National Watch Co.—the largest party from an individual house.

Manager Church, salesman Payson and accountant Glover were of the people who make the wheels go round for the Seth Thomas Clock Co.

The Waterbury Watch Co., E. F. Strickland, manager, was among the new ones. This house is the latest acquisition to membership in the association.

It was G. W. Marquardt & Sons first social entry here, but the occasion rested easily upon them. There are big events in Iowa with which the firm has been familiar.

The banquet committee can look back upon the event of 1895 without a regret at having left undone a single thing that could have increased the enjoyableness of the occasion.

An indisposition of the throat, on account of which his doctor advised against going out into the night, was responsible for the absence of Manager Prentiss, of the Gorham Mfg. Co.

The Honorable Thomas Cratty, a leading light of the Chicago bar; General H. A. Wheeler, representing the Governor and State; H. J. Furber, the capitalist who owns Chicago's great jewelry palace; Lyman J. Gage, head of the First National Bank, one of the strongest financial institutions in the country; Dr. Lawrence, the well known Baptist divine; Judge John Barton Payne, among the foremost on the Chicago bench, and John L. Shepherd,

president, Commercial Travelers' Club, guests of honor at the feast, laid aside reserve and joined heartily in the abounding good cheer. They were a goodly company.

General Manager Wygant, of the United Express Co., wrote to O. W. Wallis from West Baden Springs: "Your kind invitation is appreciated. If I did not absolutely need the rest so much I should surely come home to attend."

Professor Emil G. Hirsch, the brilliant Jewish rabbi, now of the University of Chicago, was unable to fill his appointment as speaker by reason of the illness of a son, who is low with diphtheria.

It was the first appearance in Chicago society of T. R. Barnes, the new manager of the Holmes & Edwards Silver Co., and the Manhattan Silver Plate Co.; but in his brief sojourn he seems to have made many friends.

A telegram to Jos. Fahys & Co. from Los Angeles, Cal., Wednesday announced that C. W. Harmon, New York manager of the company, was delayed by floods on his return from San Francisco and would be unable to be present.

"Here's to an intelligent jury," remarked George Hunter, as he raised his glass, and the glasses of the Elgin Co. clicked in unison. Mr. Hunter had been acquitted the day previous by an Elgin jury on the charge of violating a State labor law.

#### Women May Work More Than Eight Hours a Day in the Elgin Watch Factory.

ELGIN, Ill., Jan. 24.—The case against George Hunter, superintendent of the Elgin National Watch factory, for employing women in the factory more than eight hours per day, was decided in the police court this evening. A jury of business men and prominent citizens acquitted him. This is the second attempt on the part of Deputy Inspector Bisno, of Chicago, to convict Mr. Hunter here. There are 2,000 women employed in the factories in Elgin, and they are bitterly opposed to the enforcement of the law, declaring that it would throw them out of employment if put in force, or at least reduce their wages to a sum that would deprive them of many of the comforts of life. A majority of the women are self-supporting and fully one-half have no homes to look to or relatives to assist them.

In the case to-day two girls, Ida and Amelia Fischer, testified that they were perfectly satisfied with their employment, and they had worked several years in the factory without any perceptible injury to their health, and the factory was clean, warm and well ventilated. Assistant Superintendent Cloudman testified that it was shown that women employed in the factory worked ten hours per day, five days in the week. The work was passed from the women to the men and if the former were not allowed to work more than eight hours a day they could not employ the men longer.

### The Kent & Stanley Co. Seek an Extension of Credit.

PROVIDENCE, R. I., Jan. 24.—The somewhat startling announcement was made public this morning that the Kent & Stanley Co. requested their creditors to grant an extension of the payments maturing on stocks, notes and mortgages. The official notice sent out by order of the directors, making known the inability of the corporation to settle their obligations was as follows:

PROVIDENCE, January 23, 1895.

To the Creditors of the Kent & Stanley Co.:

We regret to be obliged to advise you that we shall be unable to meet our maturing payments as they become due, and shall be obliged to ask for an extension.

The affairs of the company are now being investigated, and as soon as a statement can be made out, a meeting of the creditors will be called for the purpose of advising with them as to the wisest course to be pursued.

In the meantime we beg your forbearance.

Yours very truly,

KENT & STANLEY CO.  
Per order of the board of directors.  
J. D. WARREN, Secretary.

The Kent & Stanley Co. are well known throughout the country as extensive manufacturers of chains and silver novelties but locally are chiefly known by the general public as the owners of the mammoth building at Sabin, Mason and Beverly Sts. The present huge factory building is pronounced by every one who has seen its modern construction to be the best and the biggest in the world; and the statement is doubtless true. For a long time the Kent & Stanley Co. have been the gossip and the wonder of the manufacturing jewelers of this city and the Attleboros. Recently the company have been negotiating for a bigger factory than the present one and an idea of what the corporation proposed can best be gained by the amount of money to be invested therein.

The scheme laid out for the new building was a marvellous one. An eight or nine story factory was contemplated, and the proposition was to bond it for \$500,000, and stock it for \$500,000 more. The plans had already been prepared, and, it is understood, accepted. The talk of the Kent & Stanley Co. business heads was to have not only one more building, but several, and the gossip of the town was the proposed centralization of the jewelry industry in the territory north of Sabin St. and west of Cove. The idea was that of a hustling pair of men, who saw the greatest future for the jewelry manufacturing business in and about Providence. The concern proposed to rent the buildings to jewelers, in apartments of any size, and furnish the power and heat and light.

It was later learned that the directors had been in session yesterday afternoon, and that within a few days a Mr. Huxley, of Boston, had been elected treasurer, to succeed Edwin F. Kent, the senior member of the firm. The officers of the corporation are at present, so far as can be ascertained: president, Arthur W. Stanley; secretary, J. D. Warren.

The present factory building is pretty well in the grip of the John Carter Brown estate, and the holder of several large mortgages, Harold Brown, is a member of the banking and manufacturing house of Brown & Ives. The mortgage loans by Harold Brown are personal accommodations and there are plenty of provisions in one mortgage which indicates a belief by the Kent & Stanley Co. members that they would soon make large payments on these mortgages. The first of the mortgages which covers the new building and the whole of the lands of the corporation is for \$150,000, and was made to Harold Brown, Aug. 13, 1894. The mortgage notes were four in number for \$25,000 each, and ten in number for \$5,000 each. The interest on this mortgage loan is 5 per cent. payable semi annually in advance.

There is also another for \$2,500, made August 14, 1893, and still a later one for \$25,000, made by the company to the same mortgagee, the latter being made Jan. 14, 1895, although not recorded until the 22d. The notes are payable in one, two and three years at 5 per cent. The first note of one year is for \$5,000, and \$10,000 is due each succeeding year. The old property owned and occupied by the firm at the corner of Eddy and Fountain streets was mortgaged Feb. 11, 1889, for \$65,000, which has never been canceled, so that the company are mortgaged to the total amount of \$242,500. It is also reported that the inability to dispose of as much as was anticipated of the capital stock is responsible for the difficulty the enterprising company find themselves in.

Besides the new building and land owned by the Kent & Stanley Co. there have been purchases of land in and about the new building by Mr. Kent, and the land formerly owned by the Barstows and others has to some extent passed into the hands of the members of the corporation.

This movement, it is understood, was in the line of gaining control of adjacent property to erect the proposed new factories, to be controlled by the corporation known as the Kent & Tingley Building and Land Co. The exact relation between this company and the Kent & Stanley Co. does not appear on the records at the State House, but stories are told of wonderful schemes afoot to embrace the whole territory in the vicinity of the factory by the former corporation.

The Kent & Stanley Co. were organized March 7, 1891. On Feb. 24, 1891, an act in amendment of an act entitled, "An act to incorporate the Eagle Furniture Company," was enacted by the General Assembly, as follows:

Section 1 of an act entitled "An act to incorporate the Eagle Furniture Co.," is hereby amended so as to read as follows:

"SECTION 1. Edwin F. Kent, Arthur W. Stanley and Daniel G. Littlefield, their associates, successors and assigns, are hereby created a corporation by the name of the Kent & Stanley Co., for the purpose of manufacturing, selling, or otherwise disposing of jewelry, plated ware, and articles useful in metal, and for the transaction of any other business connected therewith or incidental thereto, with all

powers and privileges and subject to all the duties and liabilities set forth in Chapters 152 and 155 of the Public Statutes," etc.

The capital stock was fixed at a sum not exceeding \$500,000, of which \$300,000 was paid in upon organization. On Tuesday, of this week, a return was filed at the office of the Secretary of State, showing that the balance of the capital stock (\$200,000) had been paid in.

The Eagle Furniture Co.'s charter granted Jan. 30, 1891, was never taken up and, as was customary at that time, the Kent & Stanley Co., upon deciding to become incorporated, procured the rights granted under the Eagle Furniture Co.'s charter by the special act in amendment alluded to above. Chapters 152 and 155 of the Public Statutes aforementioned give the company the right to hold or transfer real estate according to the requirements of their business.

Edwin F. Kent, Frank F. Tingley and John A. Shibley on the 10th day of September 1864, incorporated by the name of the Kent-Tingley Land and Building Co. for the purpose of acquiring, holding, building upon, improving, managing, leasing, mortgaging, selling and conveying real estate, chattel interest in realty and leasehold estates and supplying heat, light and power to the owner, tenants and occupants of real estate. The capital stock is \$1,000,000 divided into 10,000 shares of \$100 each, of which 5,000 shares are preferred stock and the remaining 5,000 common stock. The stock is entitled to receive from the net earnings of the corporation 6 per cent. per annum, and if the net earnings of any one year shall not be sufficient to pay such dividends on the preferred stock, the said dividends are to be cumulative and paid out of the net earnings of any subsequent year, but without interest. No dividends are to be paid on the common stock as long as there is any arrears of dividends on the preferred stock.

A peculiar circumstance is that said Edwin F. Kent, Frank F. Tingley and John A. Shibley only took one share each of the common stock, while the remainder of the stock remains in the treasury for future issue upon payment of the par value thereof. An amendment to the article of incorporation was adopted Nov. 17, 1894, striking out the words and figures "six per centum (6 per cent.) per annum," and substituting seven per cent.

The first meeting of the subscribers to the agreement was held Sept. 14 last, and John A. Shibley was chosen temporary chairman, and Mr. Tingley, clerk. By-laws and the constitution were then adopted. Following were the officers elected: Directors—Edwin F. Kent, Frank F. Tingley, John A. Shibley; president, Frank F. Tingley; treasurer, Edwin F. Kent; secretary, John A. Shibley. It is understood that Mr. Kent was the only "moneyed man" in the building company, and that Mr. Shibley was supposed to be the "great stock placer," and a failure would be a serious blow for the latter.

It is stated that the Kent & Stanley Co. are not embarrassed on account of their jewelry manufacturing interests, but because of trying to operate too many real estate deals. It is understood that, while the Kent & Stanley Co. built the new building on Sabin St., it was really in the Kent-Tingley Building & Land Co.'s interests.

The truth of the matter is substantially as follows: the Kent & Stanley Co. are supposed to own the new building on Sabin St. and the old Enterprise building recently vacated by them on Eddy St. When it comes to the other property to be acquired by the Kent-Tingley Co., the fee simple is supposed to be held by Edwin F. Kent and had not reached the point where the transfer was to have been made. Although the latter company were duly incorporated no deeds had been turned over to them. There are said to be two or three Boston banks, the same number in this city and one in Pawtucket involved for small amounts.

Neither secretary J. D. Warren nor Mr. Stanley, of the corporation care to say anything about the embarrassment pending a preparation of a report for the creditors and the making of a further statement by the board of directors. The statement that the affairs of the company are being investigated has aroused much curiosity and information upon this particular feature of the case was refused by everyone at the company's office. Treasurer Hoxley is busy looking into the financial end of the company and in all probability a statement will be prepared in a few days.

The Kent & Stanley Co. did business on the \$100,000 basis in about everything they touched. The commercial agencies were unable to secure any definite statement of assets and liabilities to-day. It is understood that an extension may be granted.

#### The Assets and Liabilities of C. S. Ball.

SYRACUSE, N. Y., Jan. 23.—Late yesterday afternoon the schedule of the liabilities and assets of Calvin S. Ball, who on last Tuesday made a general assignment, was filed in the office of the county clerk. The schedule showed that the liabilities on notes amounted to \$26,058.36. The assets are on stock, nominal, \$17,290.41; actual, \$15,968.23; on fixtures, nominal, \$2,480; actual, \$1,591. The schedule also showed that the cash on hand amounted to \$347.85; that accounts due the firm amounted to \$4,014.51, and also accounts of long standing due from persons whose residences are unknown amounted nominally to \$1,569.96, and actual, \$145.70.

The schedule showed further that notes amounting to \$5,000 had been given by Selleck Bros. and endorsed by Mr. Ball and also by John H. Young, of Auburn, amounting to \$4,800. The indebtedness preferred amounts to \$10,030 and not preferred to \$16,028.36. The total assets, nominal, amount to \$34,524.79 and actual, \$22,067.29. The sureties are J. Douglas Levette, Ramson B. True, Fred Barnes, David J. Francis

and A. B. Schreuder, and the amount of the assignee's bond is \$3,000.

#### Bold Sunday Morning Robbery at C. D. Peacock's Store.

CHICAGO, Ill., Jan. 25.—The night janitor at Peacock's jewelry establishment was startled from his work at 5 A. M., Sunday, by a loud noise which sounded to him like the dropping of a crowbar on the pavement. Running upstairs into the store and looking around he failed to discern anything unusual, and returned to his work in the basement. About ten minutes later he was called upstairs by a policeman rapping on the front door, who said that one of the large show windows on the north side of store in front of watch repairing department, containing opera glasses, including inside case, had been broken into.

Evidently the thief or thieves made quick work in their robbery owing to the fact that the police were on hand in ten minutes from the time of the robbery. This show window is situated near the entrance to elevator belonging to the building making it easy to watch the police as they pass to and fro on their beat; at the same time, skulking in the shadow of the large passageway, they could remain unobserved for some time watching their time to commit the robbery. On examining the surroundings a piece of iron about 12 inches long was discovered, also a full half brick which was evidently the instrument used in breaking windows. The hole looked as if a cannon ball had been shot into it.

In his haste the robber cut his hand on the jagged edges of the broken glass, leaving blood drops on the bottom of the showcase. Five Lemaire opera glasses were taken, two handled and two plain, worth in all about \$60.

#### The Firm Members of Smyth & Ashe Come to an Understanding.

ROCHESTER, N. Y., Jan. 24.—The members of the jewelry firm of Smyth & Ashe have finally come to a mutual understanding, and a dissolution of partnership is now announced. Frank A. Smyth continues the business and Thomas F. Ashe retires. About a week ago dissensions in the firm caused one of the partners to apply for a receiver.

#### An Old Jeweler's Charge of Grand Larceny.

ROCHESTER, N. Y., Jan. 25.—Frederick H. Young, a bookkeeper, who was arrested at Syracuse Wednesday on a charge of grand larceny in the first degree, was discharged in police court yesterday afternoon.

James Lusk, of this city, made the charge of grand larceny against Young. Lusk some time ago conducted a small jewelry store in a room over 161 E. Main St. In November last, it was claimed Young, who had been in the city a short time, called on Lusk and represented that he desired to sell goods for him on commission. The two

had some talk and Young called at the place several times. According to Lusk's story, Young called at his place Nov. 24th and took possession of the goods in the store, saying he was going to Syracuse to sell them. Lusk is an old man and he says he was so taken back by the man's nerve that he scarcely knew what to do. When he realized what the man was about, Lusk remonstrated with him, whereupon the man testified Young drew a revolver and threatened to shoot him if he did not give up the goods. The owner was much frightened and he said Young left the place with the goods in his possession. The goods consisted of watches and jewelry valued at \$2,149.45.

Lusk testified that he engaged Young to sell jewelry on a commission of 5 per cent. He said the man returned but \$178.

#### The Death of James Curran.

James Curran, of Leonhardt & Curran, New York, passed away Thursday morning. He died at his home in Bergen Ave., Jersey City, from heart failure, brought on by typhoid malaria, from which he had been suffering for two weeks.

Mr. Curran was a young man well known to the jewelry trade of New York. He was born in Newark, March 2, 1865, and early in life commenced to work in the jewelry trade. When about 16 years old he went to work for Dorrance, Edge & Co., of Newark, in whose office he was employed for many years. After representing several jewelry houses of Newark he started in business three years ago with G. H. Leonhardt, with whom he formed the firm of Leonhardt & Curran, manufacturers of rings and diamond mountings, 44½ Maiden Lane. The firm shortly afterward moved to their present location, 57 Maiden Lane.

The funeral services were held at the residence of the deceased Sunday, and the remains were interred at the New York Bay Cemetery.

#### The Plan of a Petty Swindler to Victimize Jewelers.

ROCK ISLAND, Ill., Jan. 26.—A fellow pretending to be a Rochester, N. Y., jeweler, was in this city this week working a more or less ingenious fake. He called on jeweler Jacob Ramser and others, and in the course of conversation mentioned the fact that he was "stranded," that he wanted to send a telegram to "the store," but that at the telegraph office after he had written the message (which he produced), 55 cents toll was demanded in advance. If he could, he would like to borrow the 55 cents for a couple of hours.

Mr. Ramser gave him the money and 25 cents for a meal, but learning later that the fellow was victimizing other jewelers in the same way, he overhauled him and secured the return of his money. The swindler's sole equipment was a pencil and a block of telegraph blanks, but he had a pocketful of money.

# THE MIDDLETOWN PLATE CO.,

IN  
CHICAGO, ILLINOIS,  
AT  
113-115 STATE STREET.

---

Goods for sale by all the Leading Jobbers and Retailers everywhere.

None but the Best Quality of Plated Ware is cheap at any price.

All Ware bearing our trade mark is of the BEST QUALITY.



We aim to excel in Beauty of Design, Fineness of Finish and Durability.

Our Tea Ware has the only genuine Non-Conductors in market,  
so far as we know.

---

# THE MIDDLETOWN PLATE CO.,

Middletown, Conn.

22 JOHN ST., New York.

120 SUTTER ST., San Francisco

# The Jewelers' Circular

AND  
HOROLOGICAL REVIEW.

PUBLISHED EVERY WEDNESDAY BY

THE JEWELERS' CIRCULAR PUB'G CO.,

189 BROADWAY, NEW YORK CITY.

A JOURNAL DEVOTED TO THE INTERESTS OF JEWELERS, WATCHMAKERS, SILVERSMITHS, ELECTRO-PLATE MANUFACTURERS, AND ALL ENGAGED IN KINDRED BRANCHES OF INDUSTRY.

Our Editorial columns will contain our own opinions only, and we shall present in other columns only what we consider of interest or value to our readers. Advertising matter will not be printed as news.

Advertising rates in THE CIRCULAR are lower, considering the number of tradesmen reached by its large circulation, than in any other jewelry journal.

Notices of changes in standing advertisements must be received one week in advance; new matter can be received up to Monday.

## INFORMATION FOR SUBSCRIBERS.

### Terms of Subscription, Postage Prepaid.

	PER ANNUM.
United States and Canada, . . . . .	\$2.00
Foreign Countries in Postal Union, . . . . .	4 00
Single Copies, . . . . .	.10

New subscribers can commence at any time. Payments for THE CIRCULAR when sent by mail, should be made in a Post-Office Money Order, Bank Check or Draft, or an Express Money Order or Registered Letter. All postmasters are required to register letters whenever requested to do so.

Pay money only to authorized collectors having proper credentials.

Returning your paper will not enable us to discontinue it, as we cannot find your name on our books unless your address is given.

In changing address always give the old as well as the new one. Your name cannot be found on our books unless this is done.

We will continue to send papers until there is a specific order to stop, in connection with which all arrearages must be paid; but such an order can be given at any time, to take effect at the expiration of the subscription. All such orders will be promptly acknowledged by mail.

The Courts have decided that all subscribers to Journals are responsible until arrearages are paid in full and an order to discontinue has been received by the publisher.

Member of the American Trade Press Association.

Vol. XXIX. Jan. 30, 1895. No. 27.

*Every line of reading matter in THE JEWELERS' CIRCULAR, with the exception of the few brief extracts from exchanges always properly credited, is written exclusively for this journal. Each issue of THE JEWELERS' CIRCULAR is copyrighted.*

### The Finding of Diamond Deposits.

THE first question which occurs to the mind upon one reading a report of the discovery of a diamond mine, such as described by St. George in his letter from Kimberley, in another column of this issue, is: "What effect will it have on the diamond trade if the report tells the truth?" In endeavoring to answer the question here, it might be well to premise our deliberations with some remarks bearing upon the publication of reports in general treating of new finds of diamonds. It has been pointed out to us by more than one diamond importer that it is a pernicious policy to publish every

wild report of the finding of precious stones that reaches the editor's desk, inasmuch as such reports tend to cause the retail dealers to infer that prices will be immediately depressed. As it is a practically impossible matter to distinguish false from authentic reports when the correspondents are thought to be truthful, a journal as THE CIRCULAR, which is essentially a news purveyor, sees no way out of the difficulty other than publishing all. And he must be a man of small mental caliber, who would expect prices to immediately fall because a small quantity of diamonds besides the output of the powerful De Beers Company might possibly be placed in the market. Should the Robinson mine prove to be the valuable property many consider it, one of two circumstances will transpire; either the De Beers Company will absorb it, leaving the diamond industry in its present monopolistic condition without any change in prices, or this company will have a competitor of considerable magnitude and prices will fluctuate in accordance with the laws of competition. The former will be the more likely outcome, if the Robinson mine is a reality. Presuming it would not be, and that the quantity of diamonds in the market was increased and the prices lowered, the demand for the gem would be proportionately augmented. The fondness for the prismatic sparkle of a fine stone is almost universal in the human heart, and the people who would buy more diamonds than they do, if the price of the gems permitted, constitute a large part of the population of civilized countries. Whatever may be the ultimate outcome of the finding of diamonds in the Orange Free State, dealers will not expect any drop of prices for some months to come at least; for operations necessary to win the precious stones in paying quantities are a work of much time.

### An Important Insurance Decision.

THE New York Court of Appeals recently handed down a decision on the law of insurance, which is of great importance to business men in general in New York State. The facts in the case were that the Home Insurance Co. had insured one, Verdier, on his stock of hardware. The policy contained the usual clause, "if the property be sold or transferred, or any change takes place in title or possession," it should be void. Verdier took a co-partner in his business and transferred to him an interest in his stock. Subsequently the fire occurred. The Court decided that the admission of a new partner made a change in the firm which vitiated the insurance, the contract for which was personal in its nature. As this decision comes from the Court of Appeals, it is not open to dispute; however, it will prove to be news to almost all merchants and to many lawyers. Business men have considered that any change taking place in a co-partnership did not affect its ordinary contracts, particularly

not its insurance. It is safe to say that there is not one merchant in a hundred of those who take in a new partner or buy out the interest of an old one who has thought it necessary to make any change in the firm's policies of insurance. The publication of this decision will apprise many jewelers that their policies, upon which they have relied for protection, have lapsed, and that in the case of loss by fire they could recover nothing. The many firms who have made co-partnership changes with the beginning of the new year should notify their insurance companies, and so place themselves beyond the likelihood of litigation.

THE profuse wearing of jewelry is the order of the day in the fashionable circles of Paris, even young girls being lavishly bedecked with costly ornaments, a circumstance which a few years ago was deemed unsuitable for their age. The fashion will soon spread to New York, Paris having led the way. All varieties of jewels adorned with all the colored stones are displayed on every hand and it is evident that the theory that jewelry is a "relic of barbarism" is not widely espoused in the French capital. And it is a fact bearing peculiar significance in the face of the cataclysm of such blatant theories as the foregoing, that eminent figures of noted artistic periods of the past are depicted, by pen or brush, as heavily borne down with the weight of jewels, or at least generously bedecked with them.

### The Death of C. A. Morse.

CHICAGO, Ill., Jan. 25.—C. A. Morse, brother of F. E. Morse, and in the jewelry business here for some 35 years, died the 19th inst., from stone in the bladder. Mr. Morse had not been actively engaged in business for the past ten years. His affliction had been coming on for the past five years.

He was 76 years of age and left a son and daughter, both married. The funeral took place the Sunday following, from the residence of his daughter in Englewood, with whom he had made his home. Remains were interred in the family lot at Oakwood cemetery. [The death of Mr. Morse removes another of the pioneers of the trade of this city, in which deceased had many warm friends.

### A False Rumor Affected Charles F. Dufeu's Credit.

CHILLICOTHE, O., Jan. 24.—This week Charles F. Dufeu, the oldest jeweler in this city, made an assignment to John P. Phillips. Recently, in a suit that was instituted, some money in the hands of Mr. Dufeu was garnished, which was the cause of a false rumor getting out about his financial condition, and creditors swarmed in upon him. The assets amount to about \$25,000 and liabilities will run almost as high. Preferences of \$8,000 were given by Mr. Dufeu to members of his family.

### New York Notes.

C. W. Schumann, Jr., has entered a judgment for \$493.57 against Geo. H. Grossman.

Niagara Silver Co. have entered a judgment for \$440.72 against Abraham Schieber.

A judgment for \$104.30 has been entered against Nathan Rogers by the Ladd Watch Case Co.

Stephen Rock, 195 E. 3d St., has renewed a chattel mortgage on his jewelry stock to F. Kaffeman for \$650.

A judgment for \$155.05 against Abraham Schieber has been entered in favor of the Matthews & Willard Mfg. Co.

J. C. Wakefield, of Aikin, Lambert & Co., has been confined to his home in Bayonne, N. J., with an attack of the grip.

The action of Freudenheim & Abramson against Julia Raduziner has been restored to the day calendar of the City Court and is set down for trial on Feb. 4th.

A fine exhibit of standard cyclometers was made by the New York Standard Watch Co., last week at the Cycle Show held at Madison Square Garden.

By a mistake the name of M. J. Lasar appeared among those of the creditors of Bernard Berman, published last week. Mr. Lasar states he never sold to Berman.

Emile Philippe, of Geneva, Switzerland, has been visiting this city. Mr. Philippe is a member of the watch manufacturing firm of Patek, Philippe & Co. He arrived on *La Bourgogne* Jan. 20th.

Judge Daly, of the Court of Common Pleas, Saturday, extended the time in which John J. Connelly, assignee of Frank Bayerdoerfer, is to file his schedules until 20 days from that date.

Historical Sketch of Madison Square is the name of a handsome monograph issued by the Meriden Britannia Co. in commemoration of the recent removal of their New York store from Union Square to Madison Square. The souvenir is a neat specimen of the printer's art.

At a meeting of the United Watch Case Makers' Association, held at 407 Bridge St., Brooklyn, last week, a committee was appointed to draft a letter to Mayor Schieren containing the resolutions which the association passed, in which they express their sympathy with the striking trolley car employes.

A blonde young man about 21 years old called at the office of M. B. Bryant & Co., 10 Maiden Lane, Jan. 22d, and stating he was the son of Walter C. Potter, a Boston jeweler, ordered goods worth between \$500 and \$600. He said he would call and pay for the goods the next day. A telegram by M. B. Bryant & Co. to Mr. Potter brought the answer that the latter had no son, and there was no one in New York to represent him. The young swindler did not return.

One of the thieves who early in the morning of Jan. 15th smashed the window of Mrs. Lynch's branch jewelry store, 1123 Broad-

way, and stole a quantity of jewelry and opera glasses, was captured by the police Friday last. Detectives arrested him after seeing him pawn an opera glass at Simpson's, on Chatham Square. He confessed having been one of the window robbers and gave his name as Edward Crooks, 513 Wythe Ave., Brooklyn. He was held for examination.

Stephen G. Patterson, assignee of Jos. Rundback, applied to Judge Daly, of the Court of Common Pleas, Saturday, for another extension of time in which to file his schedules. In his affidavit he says that he is unable to obtain part of the assigned property, which is in the hands of property clerk Harriot, to be used as evidence in the criminal proceedings against Rundback. The assignee also states that he has reason to believe that Rundback has settled with all his creditors. Judge Daly granted an extension of 30 days.

Judge McAdam and a jury, in the Supreme Court, Thursday, heard on a retrial, the suit brought by Sarah A. Carson against Simon Dessau, formerly a dealer in diamonds and bortz, at 4 John St., from whom she sought to recover \$50,000 damages for false arrest. Miss Carson claimed that on Feb. 9, 1889, when she called at Dessau's office to collect a bill, he refused to pay it and caused her arrest on a charge of blackmail. In the Police Court she says she was fined \$10 for disorderly conduct. The jury gave Miss Carson a verdict for \$3,500. On the first trial she was awarded \$3,000.

A. S. Koplik & Son, 247 Sixth Ave., confessed judgments Jan. 22d to Rosalie Koplik for \$3,627 and to Isaac Hirsch & Son for \$774, both for borrowed money. The failure is attributed to very poor business. The liabilities are said to be \$15,000, of which \$8,500 is due to the wife of the senior partner for money she borrowed from a life insurance company and put in the business. The assets are estimated at \$10,000. The firm consists of A. S. Koplik and his son, Samuel J. Koplik, the father having been in business since 1855. Samuel J. Koplik was admitted as a partner about three years ago after being employed in the business about ten years.

The United States Circuit Court of Appeals, Wednesday and Thursday heard the appeal from the decisions of the Circuit Court in the suits of Ecaubert *vs.* Appleton and Appleton *vs.* Ecaubert. The former suit was brought by Frederick Ecaubert against Robbins & Appleton for alleged infringement of a patent granted to Ecaubert on a machine for ornamenting watch case centers. The cross suit brought by Robbins & Appleton against Ecaubert was to set aside this patent. The decision of the Circuit Court before whom the cases were tried last February declared that the patent in question was wrongfully issued to Ecaubert, and rightfully issued to one Hoffman, an employe of Robbins & Appleton. An appeal was taken from this de-

cision, which was argued last week as before stated. Decision was reserved.

A cool theft was attempted Thursday at the jewelry store of J. H. Johnston & Co., 17 Union Square. The Rev. Joseph A. Harper, a salesman in the store, while attending to two young men who were looking at studs, noticed a suspicious movement of the hand by one of his customers. When the men started to go without purchasing, Mr. Harper grabbed the man he suspected and putting his hands in the man's pocket pulled out a card of studs valued at \$33, which had been stolen from the tray. The thief grappled with his captor and continued the fight out to the sidewalk where Detective Jacobs arrested him. In the confusion his companion escaped. In the Jefferson Market Police Court he gave his name as Harry King, of Norfolk, Va. He was held for trial in \$1,500 bail.

The schedules of Simon Black, 14 John St., which were filed Jan. 22, show the assets of the insolvent to be nominally \$8,398.41 with an actual value of \$3,328.41. They consist of merchandise worth \$2,978.41 and a safe and fixtures worth \$350. The remainder is in uncollectable accounts. The liabilities amount to \$12,294.85. The merchandise creditors are Greene & Knox Mfg. Co., \$307.26; W. C. Edge Co. \$213.60; Stern Bros. & Co., \$980.50; Potter & Buffinton \$412; Bugbee & Niles, \$145; J. Bulova, \$187.95; Rothschild Bros., \$164.50; Waite, Thresher Co., \$267.48; B. Sugarman, \$329.50; Morris Prager, \$505.97; M. J. Lasar, \$1,675.07; Max Freund & Co., \$986.80; Maurice Weil, \$486.27; H. Z. & H. Oppenheimer, \$819.59; M. Kollender, \$600.80; R. A. Breidenbach, \$959.91; J. M. Lyons, \$771.53; M. Damast, \$1,299.18; C. Cottier & Son, \$481.50; Otto Kruh, \$150.94 and E. L. Anrich, \$544.44. Mr. Black assigned Jan. 17th to Warren S. Burt. The assignee has given a bond of \$5,000.

Jacob Ritter, 461 Eighth Ave., New York, and Hoboken, N. J., is offering a compromise. In response to a call sent out by Hays & Greenbaum, as attorneys for Ritter, a number of the creditors met at the offices of the law firm, 170 Broadway. The creditors present who represented merchandise indebtedness amounting to about \$12,000 out of the total liabilities of \$16,000, were made an offer of settlement at 40 per cent.; 25 cents cash and the remainder in two notes due in four and eight months. The acceptance of this offer the creditors unanimously agreed to recommend, and papers embodying the proposition are now being circulated. Ritter owes \$550 to his bank and also owes for cash lent by his wife and sons. The last two, it is said, however, are willing to waive their claims if the settlement can thereby be accomplished. About two weeks ago an attachment was issued against Ritter for \$200 in favor of Isaac Smith's Sons. This was paid, and Ritter then removed his stock to Hoboken.

*Continued on Page 53.*

**L. TANNENBAUM & Co.,**  
IMPORTERS AND CUTTERS OF

**Diamonds and Precious Stones,**

Cor. Maiden Lane & Nassau St.

**NEW YORK.**

25 Hatton Garden, London.

TELEPHONE, LONG DISTANCE 1959 CORTLANDT.

## Special Announcement.

Mr. L. Tannenbaum begs to notify his customers and the trade in general, that he has largely extended his facilities for cutting and polishing. Hereafter he will cut and polish not only RUBIES and SAPPHIRES, which has been done for the past 15 years with increasing and gratifying success, but

# DIAMONDS

and all other stones which undergo this process.

Modern machinery of the best and most approved pattern, and workmen of the highest class will enable Mr. Tannenbaum to offer, direct from the cutter's hands, that excellent workmanship demanded by American buyers, at

## PRICES THAT DEFY COMPETITION.

Nor will buyers of Diamonds be the only people benefited. Mr. Tannenbaum imported a five years' supply of rough Rubies and Sapphires DUTY FREE under the old tariff. These goods are now being cut and polished and it is very evident that in these particular stones he can make UNAPPROACHABLE PRICES.

New York as the future Diamond Market is not a phantasy. American cutters will be shown an assortment of rough, at prices which will perhaps cause them to believe that this has already been brought about. All arrangements have been made by the firm for enormous shipments of DIAMONDS, EMERALDS, PEARLS, SPINELS, CATSEYES, MELLEES and all kinds of Precious Stones, although to-day the assortment offered by L. Tannenbaum & Co. ranks second to none in this country.

 HIGHEST PRICE PAID for all AMERICAN PEARLS and OTHER PRECIOUS STONES.

# French Coffee Percolator.



FRENCH COFFEE PERCOLATOR.

This French System of Percolation produces the very best results. Extracts the entire strength of coffee by this double filtration. Made in any style of bright cutting or plain.

Sizes 2, 3 and 4 quarts.



The Manhattan Silver Plate Co. are the original makers of this Urn, which has been pronounced by lovers of good coffee, the only perfect article of its kind manufactured in Silver Plated Ware.



COFFEE PERCOLATOR.  
Cut showing inside Filtering, Etc.

**SALESROOMS :**

23 John Street, New York.

65 Washington Street, Chicago.

CATALOGUES  
AND PRICE LISTS AT  
ALL OUR  
SALESROOMS.

508 Chestnut Street, St. Louis.

120 Sutter Street, San Francisco.

## SOMETHING NEW!!

Inside Plate is granite ware or earthen plate, used by housekeepers, in which you bake the pie and then place it in the Silver Dish to serve on the table—being not only ornamental but very useful, and will be appreciated by everyone.

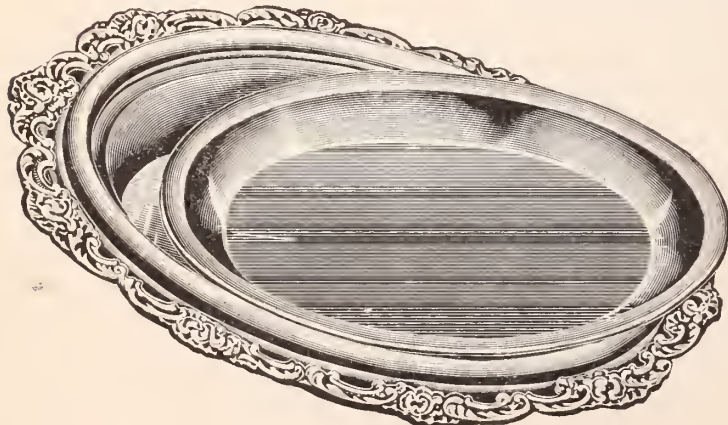

PIE BAKING PLATE.



PIE BAKING PLATE.

**MANHATTAN SILVER PLATE CO.,** FACTORIES, **LYONS, N. Y.**



# THE HOLMES & EDWARDS SILVER Co.,

BRIDGEPORT,  
CONN.,

are the largest manufacturers of Silver Table Flatware in the country. Their

goods are every-  
where known as  
the finest in quali-  
ty and finish. In  
Sterling Silver In-  
laid quality, Trade



WALDORF PATTERN.  
TEA SPOON

Mark, "E STERLING INLAID HE." The two new Steamships, "St. Louis" and "St. Paul," are to be furnished with Inlaid quality.

The Waldorf and Rialto are the most popular patterns made in the Inlaid quality and Special XIV



RIALTO PATTERN.  
TEA SPOON.

in fancy pieces. Ladles in this pattern are most artistic. Leading jewelers pronounce them beautiful.



DELSARTE PATTERN.  
TEA SPOON.

"XIV."

on fancy pieces in lined boxes meet the demands of the best trade.

The Government give their endorsement on Holmes & Edwards goods.



DELSARTE PATTERN  
MEDIUM FORK.

CHICAGO SALESROOMS, 65 WASHINGTON STREET.

T. R. BARNES, Manager,

WILLIS W. BROWNE, Asst. Manager.

NEW YORK,  
2 Maiden Lane.

ST. LOUIS,  
307 N. 4th Street.

SAN FRANCISCO,  
120 Sutter Street.

THE HOLMES & EDWARDS SILVER Co., BRIDGEPORT, CONN.

# SETH THOMAS CLOCK CO.,

(ESTABLISHED 1813.)

FACTORIES, - - - - - THOMASTON, CONN.

MAKERS OF

## CLOCKS AND WATCHES.

No. 785.

LOUVRE.

Marqueterie Panel, Mahogany Front, With Polished Brass Inlay, Gilt Metal Trimmings.

Wood Case, Adamantine Finish. Bronze Metal Trimmings.

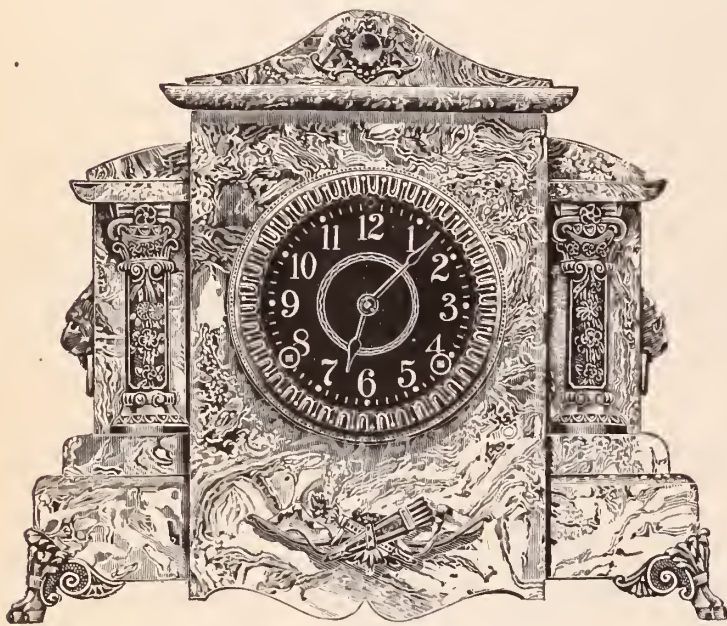

Height, 12 3/4 inches. Base, 15 inches.  
8 Day, Spring, Strike. Cathedral Bell. 5 inch Dial.



Height, 16 inches. Base, 10 inches.  
Cathedral Bell. - - - 4 inch Porcelain Dial.



No. 202. Hunting, Nickel. 18 Size. 15 Jewels. Adjusted. Micrometer Regulator.



No. 119. Nickel. 5 Size 15 Jewels.



Maiden Lane. O. F. Nickel. 17 Ruby Jewels in Gold Settings. Adjusted. Micrometer Regulator. Breguet H. S. D. S. Dial.

OFFICES AND SALESROOMS:

149 and 151 STATE STREET, CHICAGO.

49 MAIDEN LANE, NEW YORK.

126 SUTTER ST., SAN FRANCISCO.

# SIMPSON, HALL, MILLER & CO.,

141 and 143 STATE STREET, - - CHICAGO, Ill.

MANUFACTURERS OF - - - -

THE HIGHEST  
QUALITY QUADRUPLE  
SILVER PLATED HOL-  
LOW WARE.



TRADE MARK FOR  HOLLOW WARE.

MANUFACTURERS OF - - - -

THE GENUINE  
WM. ROGERS  
KNIVES,  
FORKS,  
SPOONS, Etc.



TRADE MARK FOR FORKS, SPOONS, ETC.

 **W. ROGERS**,  
Wallingford, Ct.



FACTORIES:

WALLINGFORD,  
CONN., U.S.A.



Write for Our New Illus-  
trated Catalogue No.  
27, of Knives,  
Forks, Spoons, Etc.

No. 7700, Epergne, Silver Embossed, Gold Lined Bowls.  
Height, 24 inches.

# GENEVA OPTICAL CO.,

..... CHICAGO, U. S. A.,

WISH TO CALL THE ATTENTION OF THE TRADE TO A FEW OF THEIR SPECIALTIES.

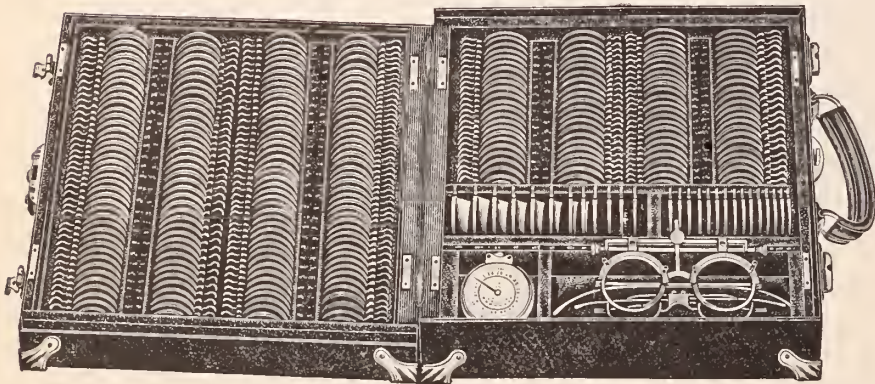

No. 1004 and 1008. Open.



No. 1004 and 1008. Closed.

## FOLDING CASES OF TRIAL LENSES.

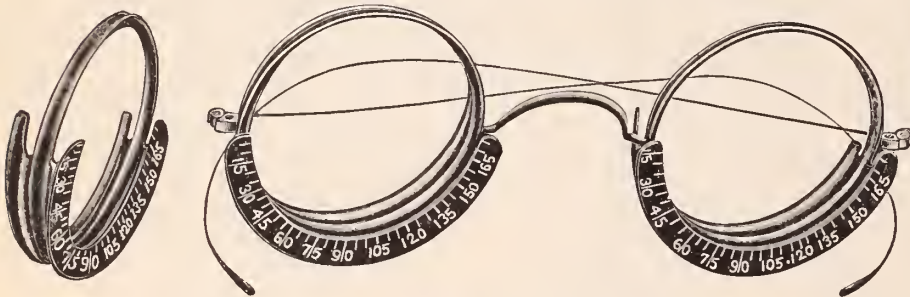

No. 1050 "FAIRIE" TRIAL FRAME.  
Aluminum, Weighs but One-Quarter of an Ounce.

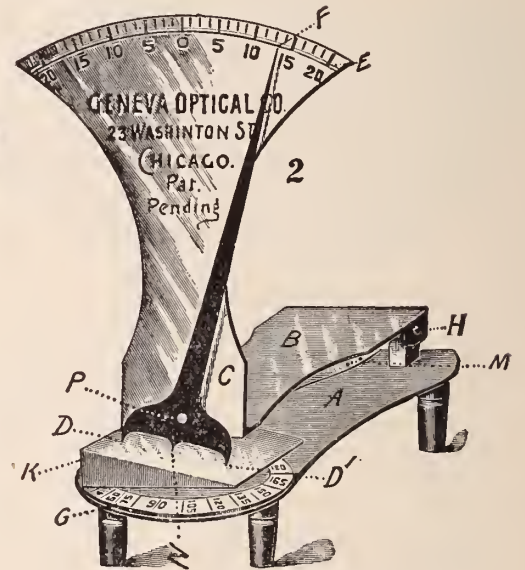

PRISM MEASURE and LENS CENTERING INSTRUMENT.

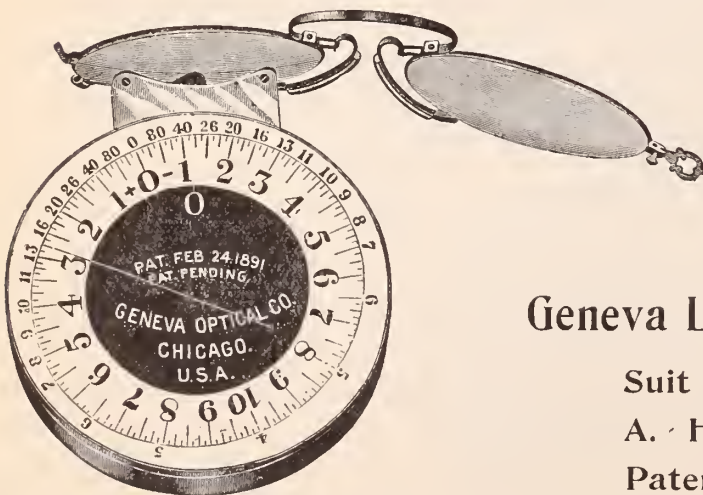

## Geneva Lens Measure.

Suit was entered January 10th, against The F. A. Hardy Company, for infringement of our Patents on Lens Measures.

CATALOGUE MAILED ON APPLICATION.

# THE MAGNITUDE OF THE CHICAGO JEWELRY INDUSTRY.

## The Ramifications of Otto Young & Co.

AS typical of the resistless energy that has figured so largely in promoting the rapid growth of Chicago, a visit of inspection to the mammoth salesrooms of Otto Young & Co., 149-151 State St., should become the duty of every jeweler visiting



OTTO YOUNG.

the city. The tireless energy of Julius Schnering, the active manager and Co. of the firm, seems to have inculcated every employe with a spirit of activity that is unusual, even in this bustling city. With



JULIUS SCHNERING.

an army of assistants in the many departments the effect is that of a vast beehive of commercial industry.

At first sight there is a sense of bewilderment, but so well managed are all the minor details that each employe is but a part of that wonderful machine—a great jobbing

house—which distributes its products worldwide. Away in the distance we hear the stentorian voices of the callers as they repeat to the entry clerks the bills ready for shipment, and yet, though half a block distant, this is but a part of the great scene before us. The various enterprises with which Mr. Young is connected require the greater portion of his time, Mr. Schnering having so absolute a management of the jewelry interests that the former appears rather in the light of a consulting partner.

The present quarters have been occupied by the firm for 24 years, and the wonderful development of the house in that time to a foremost position among business houses of the west, is one of the best examples of what executive ability can accomplish when associated with sound business policy. The stock of Otto Young & Co. is a complete index of all the newest and latest productions required by the retail jeweler.

## The Beauty of the Towle Mfg. Co.'s Product.

THE truly remarkable growth of the Towle Mfg. Co. is without a parallel in western business circles. Incorporated in 1880 with a small capital the company has in the few years since then rushed into the foremost ranks of silver manufacturers. From 1880 with its future all before it, to 1895 with success and high standing assured, is a phenomenal record, and it is one not secured by "boom" methods, as grow the mushroom "cities" of the far west, but rather, was brought about by conservative, far sighted business men who accepted an offered business opening, and from indications have made the most of their opportunity. Before the holidays the writer was passing the silver display in the window of a leading Chicago jewelry house when he heard a lady remark:

"Aren't they beautiful?"

Her escort replied: "They are, indeed. Which do you prefer?"

"Really, I do not know," she said, "they are both so pretty."

Now, it happens that the listener, being a married man, knew a woman whose judgment, so far as it relates to household articles, is to him final, and shortly after passing the same window he called her attention to the silver display.

"They are very handsome," she commented, and when asked as to her choice

replied "really, either would be very acceptable."

Her escort remarked, after telling of the conversation previously overheard and speaking of the oneness of sentiment, "That is a strange coincidence."

"Not at all," she quickly responded, "it is a 'natural coincidence.'"

And after all it is but natural, for the patterns under inspection were the "Empire" and "Old English" of the Towle Mfg. Co., 149-151 State St. To the connoisseur in silver there would seem a wide difference in the two patterns; to the purchasing public who look more to effect there is a difference, but less wide. The "Empire" is extremely chaste in design while the pop-



J. A. TODD.

ularity of the "Old English" depends rather upon a certain richness than on simplicity of design.

It is probable that the choice patterns issued by the Towle Mfg. Co. are to a large degree responsible for the activity in both factory and salesrooms. Manager Todd affirms that this is true.

## "The Busiest House in America."

"THE busiest house in America" is no misnomer when applied to the great commercial establishment of Lapp & Flershem, northwest corner State and Washington Sts., Chicago. And yet, as time is measured in other cities, it was but yesterday that Ohio and New York, the respective birth places of the members of the firm, joined hands to establish in Chicago a business that has already exceeded in volume the most sanguine expectations of its founders. The firm consists of Peter Lapp and Lem W. Flershem, each

a man of rare business qualifications, each self-taught in the school of practical commercial life by advancing through the various grades of promotion in the wholesale jewelry business in the employ of others before venturing on the sea of commerce themselves.

Thus equipped with a complete knowledge of details the firm began business in 1876 in



PETER LAPP.

L. W. FLERSHEM.

LAPP &amp; FLERSHEM.

a modest way, with a small and well selected stock, at the corner of Madison St. and Fifth Ave. At the commencement they were long on experience and stock and short on customers. With a "go-ahead-itiveness" characteristic of both men, efforts were properly directed looking to an enlargement of trade, and the results were so gratifying that the little 20x40 office was soon exchanged for salesrooms at 141 State St., quadruple in size their former quarters. These seemed sufficient in size for all time to come, but the firm outgrew their space within two years and a removal to 81 State St., followed, this location in turn being given up by a change to their present quarters, northwest corner State and Washington Sts., where fifteen times the space originally started with was further increased by the building of suspended half-floors for stock.

The history of the house from its inception in 1876 to its present magnificent proportions is an object lesson as to what fidelity to details, enterprise and liberal dealing may accomplish when coupled with honesty and foresight. The title of "Busiest House in America," in the words of the bard of the jewelers' banquet of two years ago, "came to stay," and is not only appropriate to this energetic house but a deserving merit. The laurel wreath of success has crowned their efforts, but Messrs. Lapp and Flershem as practical and progressive men care little for laurel leaves and crowns and such like "fixin's" but are actively in "harness" that they may with real merit and true worth go forward to still greater achievements in the world of trade.

### The Extensive Ramifications of the Ansonia Clock Co.

THE name "Ansonia" is synonymous with all that is artistic in clock architecture. Unconsciously one associates the word not only with clocks themselves, but also as a designation of that class of clocks which combines accuracy in timekeeping qualities with the choice and popular designs which have aided so largely in giv-

ing fame to the factory as a leader in case construction. As to intrinsic merit of movement and elegance of case design the trade is already so well informed that it were superfluous to here go into details as regards the productions of the Ansonia Clock Co.

The company, by consolidation with several concerns, dates its birth forty years back. Its works were then in Ansonia, Conn., but were shortly after established at Brooklyn, N. Y., where an entire block, four acres in extent, covered with five and six story buildings, is required for the conduction of its enormous manufacturing interests, with a range of production extending all the way from the to many indispensable nickel alarm to the most costly and ornamental art works in rare marble and bronze. Besides the main offices, at 11 to 21 Cliff St., New York, from which its large operations are conducted, the company has salesrooms at 11 Cortlandt St., New York, a circulating depot at 23 Fore St., E. C., London, England, and an extensive office and elegant salesrooms at



E. D. BARNUM.

133-135 Wabash Ave., Chicago, for the convenience of its large and constantly growing list of customers in the west. The latter branch has been in operation for fifteen years—at first at 65 Washington St., later moving to No. 64 of the same street, and six years ago, having outgrown its old quarters, moved to its present location, where double the former space is occupied.

E. D. Barnum, manager of the western branch, has been associated with the company for eight years, and during that time has, by his well directed efforts, aided efficiently in the rapid progress the company has made, and is making in western business. In the clock business Mr. Barnum has worked from the ground up. At the time of the great Chicago fire he entered the employ of the American Clock Co. as bookkeeper. After the dissolution of the company he engaged with the E. N. Welch Mfg. Co. for several years as salesman and later was jewelry traveler for T. I. Smith & Co., of Attleboro. In 1887 he accepted the position of manager for the Ansonia Clock Co., in charge of the western office, and jewelers will find no more cor-

dial greeting anywhere than that extended by Mr. Barnum to callers at the Chicago salesrooms, 133 and 135 Wabash Ave., this city. Even in the line of information as to advancement in clock mechanism, a visit to the handsome salesrooms will be of interest.

### The March of Progress of G. W. Marquardt & Sons.

FORTY-ONE years have passed since G. W. Marquardt established the house of G. W. Marquardt & Sons in Iowa City, Ia. For 26 years the youngster thrived and grew fat, but there were limitations which prevented it becoming a giant. Casting aside the swaddling clothes of its birthplace it went in 1881 as a youth to Des Moines, Ia., where facilities were better for a larger commercial development. With a healthy increase for 13 years in that city, it became "a strong house in the field with its contemporaries" and like Alexander of old looked for new worlds to conquer. All roads in the west lead Chicagoward, and hither came this stripling, now grown to man's estate. And to put it mildly the firm have created a stir. They had no need for money; in fact, they had a whole bankful in Iowa, and though they have been in Chicago but a few months, the appearance of their salesrooms on the fourth floor of the Columbus Memorial building, indicates that they do not lack for customers; in fact, G. W. Marquardt & Sons have outgrown their quarters in their first year of business in Chicago. And it wasn't the fault of the quarters; they seemed ample enough, but the firm spent \$10,000 or \$15,000 on a book.

This book was got up rightly, and it told all about what the firm would do if the retail jeweler would give them a chance. Word got out in some way that the book was a pretty handy thing to have around,



G. W. MARQUARDT, JR.

and the result was that every jeweler wanted one. The firm set forth the claim, in silver lettering on the lavender cover of the book, that their prices were lower than those of any others, and perhaps this was what caused the demand. Well, the trade kept asking for them and the edition ran out, but the firm said they had noticed there were

Ask your  
Jobber for



Elgin's New  
Twenty Ruby Jeweled  
Eighteen Size Nickel Movement

Hunting or Open-Face.  
Adjusted to Temperature,  
Isochronism and Position.  
Escapement Cap Jeweled.  
Jewels in Gold Settings. Micrometer Regulator.  
Breguet Hairspring.  
Glass Enamel Double-Sunk Dial.  
Finely Finished Throughout.

Manufactured by the

**Elgin National Watch Company,**

General Offices: Chicago, Ill.  
New York Office: 11 John Street.

Elgin, Illinois.

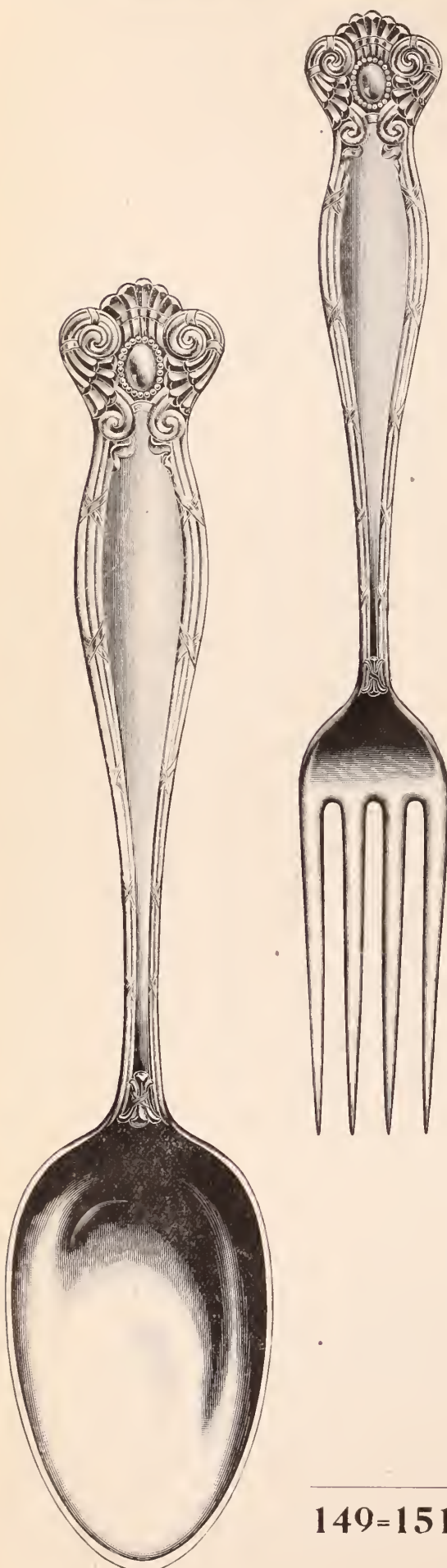

# EMPIRE.

\*\*\*\*\*

TEA SPOONS, small,	-	-	-	-	8 Ounces.
TEA SPOONS,	=	=	=	=	10, 12, 15 "
TABLE SPOONS,	-	-	-	-	24, 28 "
TABLE SPOONS, large,	-	-	-	-	32 "
DESSERT SPOONS,	-	-	-	-	17, 20, 24 "
DESSERT FORKS,	-	-	-	-	17, 20, 24 "
MEDIUM FORKS,	-	-	-	-	24, 28 "



# Towle Manufact

# SILVER

—DESIGNERS

**STERLING**

CHICAGO:

149-151 STATE STREET.

**TA**  
**W**  
 IN ONE C







# OLD ENGLISH.

\*\*\*\*\*

TEA SPOONS, small,	-	-	-	-	8, 9 Ounces.
TEA SPOONS,	-	-	-	10, 12, 15	"
TABLE SPOONS,	-	-	-	24	"
TABLE SPOONS, large,	-	-	-	28	"
DESSERT SPOONS,	-	-	-	18	"
DESSERT FORKS,	-	-	-	18	"
MEDIUM FORKS,	-	-	-	24	"

Manufacturing Company,  
**SMITHS.**

MAKERS OF

BLE  
ARE



## SILVER

### NEWBURYPORT, MASS.

*Correspondence Solicited from the Jewelry Trade.*

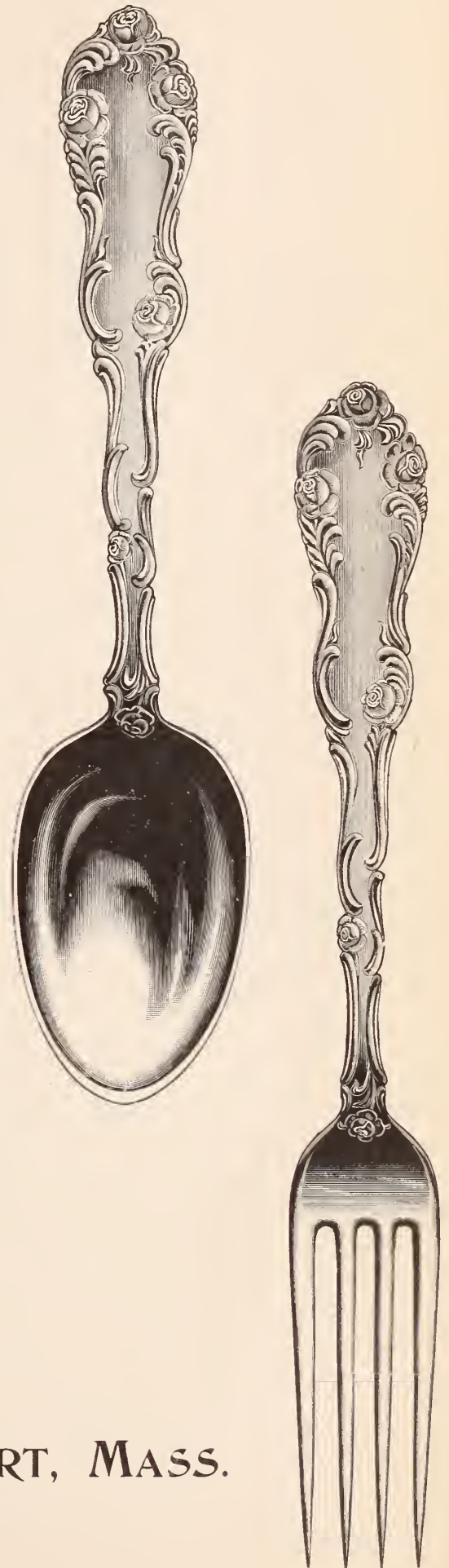

LITY ONLY,  
5  
00  
IE.

*Established 1844.**Incorporated 1878.*

# DENNISON MANUFACTURING Co.,

## PAPER JEWELRY BOXES.

MOROCCO,  
PLUSH,  
VELVET,  
CELLULOID,

ASES.

PLUSH,  
LEATHER,

SHOW CASE MATS.

CHAMOIS,  
PLUSH,

OPERA GLASS BAGS.



Job or Repair Envelopes, Jewelers' Cotton, Chamois Watch Bags, Silver  
White, Cleaning Caskets, Jewelry Soap, Sealing Wax,  
Jewelry Cards.



## Dennison's Grass Bleached Tissue Paper.



Rubber Bands, Tags, Gummed Labels, Dennison's Watch Papers,  
Dennison's Folded Diamond Papers, Chamois Skins, Boxwood  
Saw Dust, Dennison's Show Case and Window Trays.

*All of the above goods sold at our different stores.*

90 & 92 WABASH AVENUE, CHICAGO.

26 FRANKLIN ST., BOSTON.

198 BROADWAY, NEW YORK.

630 CHESTNUT ST., PHILADELPHIA.

143 WALNUT ST., CINN., O.

413 NORTH FOURTH ST., ST. LOUIS.

plenty of printing presses in Chicago and if the jewelers wanted the book so badly they should have it, and another edition was run off.

From the title page to the back cover every one of its 496 pages has its interest. Besides, each is fully illustrated, with the latest in patterns and styles, and the price is there in plain figures. There's some good advice and information of value in some additional pages, but there's no use in trying to tell all about a 500 page book in a 2 x 4 space; the best way is for the jeweler himself to write for it, if he has not already done so.

### The Enterprise of F. M. Sproehnle & Co.

LOOKING back on the few years intervening since 1883 and the present, F. M. Sproehnle & Co., Chicago, should find cause for congratulation in the truly remarkable growth of their wholesale jewelry



F. M. SPROEHNLE.

establishment. One is forced to the conclusion that such unexampled increase is not the result of any ordinary business management, but is due rather to exceptional ability and a breadth of trade insight



A. W. SPROEHNLE.

that few possess. The firm commenced business in a little 2 x 4 room on the 6th floor at Randolph and Dearborn Sts. in 1883 as Bryant, Sproehnle & Co., and memory could easily have served as bookkeeper. They continued in a small way for four years, when Albert W. Sproehnle purchased Mr. Bryant's interest, the latter retiring.

In 1887 the firm, consisting of F. M.

Sproehnle and Albert W. Sproehnle, brothers, became more pretentious by the removal to second floor quarters at 110-112 Wabash Ave. Here the possibilities for larger growth became recognized and with increased business the firm in 1892 secured a fine location at 195-197 Wabash Ave., the trend of business having turned toward Van Buren St. Here they occupied spacious quarters—2,200 square feet on the second floor—and were directly in line with the southward advance of the jobbing interests. This advance was checked by the completion of the Columbus Memorial building at the southeast corner of State and Washington Sts., and the jewelry interests became firmly centered on State St.

With a constant growth for several years, the brothers felt assured of a strength sufficient to compete with the then larger houses, and on the completion of the Columbus Memorial building they took a long stride to the front by securing an entire half of the third floor, the most desirable floor in this commercial palace. May 1, 1893, found them in their new quarters and present location, with an assortment of general jewelry lines which it was a pleasure to them to present for the inspection of their greatly enlarged list of customers. The growth of recent years was here largely augmented and to-day the firm look back without a regret over the business opportunities which they have so signally mastered.

From the time the brothers engaged in business the house doubled its business each year for three years, and has had an uninterrupted and healthy increase in business ever since. The past year the firm have increased the working force 25 per cent. to keep pace with the growth of their business. They employ no travelers, but publish "The Salesman," a catalogue work of unusual excellence, which laid open upon the counter of a retail store will promote sales and give the retailer the advantage of complete wholesale lines at prices that make them profitable to the retail dealer.

Frank M. Sproehnle, the senior member of the house, was born Feb. 28, 1859, on Van Buren St., near the present Board of Trade. He attended the public schools till he was 14 years of age. At 14 he was given choice between a business education and a preparatory collegiate course and he selected mercantile life, engaging as errand boy for B. F. Norris, Alister & Co., at \$4 per week. Ten years later he had by successive promotions secured the highest position the house had to offer, that of credit manager. In 1883 he engaged in business on his own account with the brilliant success above noted. Jan. 11, 1893, Mr. Sproehnle married Miss May Reeves Caliger, of this city, and a boy of 13 months blesses the union.

Albert W. Sproehnle, the junior member, is also a Chicago boy, dating from Oct. 31, 1862. He also studied in the public schools till 14, when he entered the employ of a stove manufacturer, and was advanced by promotion until his eyesight failed and he

was obliged to give up office work. He then conducted a grocery business for four years, later going to Notre Dame University, where he studied law. On the completion of his law course he was induced to give up the profession and take Mr. Bryant's interest as his brother's partner. The result has been exceedingly happy.

### The Output of the Seth Thomas Clock Co.

IN the Seth Thomas clocks are embodied the basic principles of accurate timekeeping with the improved mechanism developed by later-day ingenuity. The Seth Thomas Clock Co. is a development of the old American Clock Co. which in turn was the consolidation of the leading clock companies of its day, thus giving the Seth Thomas Clock Co. a monopoly of the best ideas of the times as a foundation, to which has annually been added the highest inventive skill. This company is the oldest in its line in the country, dating its establishment to what was then known as Plymouth Hollow, Conn., in 1813. The name of the town was later changed to Thomaston, where the mammoth plant is still located.

The production of the factory is of the



GEO. W. CHURCH.

widest range, covering the smaller classes for household use of whatever nature, and extending through the entire line of clocks for the office, salesroom, or factory, to the handsome line of jewelers' regulators and huge tower clocks which decorate the court houses, public buildings and schoolhouses throughout the land. The western office is at 149-151 State St., Chicago, a central location in the very heart of Chicago's jewelry jobbing trade. Being so easy of access, a cordial invitation is extended by Geo. W. Church, manager of the company's western business, to jewelers visiting that city, to inspect the latest productions of the factory, among which are to be found some specially interesting moderate priced lines of this season's goods that are meeting with special favor. Mr. Church has been associated with the company for many years, and besides having a thorough knowledge of the subject of clocks, is one of those genial business men whom it is always a pleasure to meet.

### The Chicago Branch of the Dennison Mfg. Co.

WITH factories at Brooklyn, N. Y., Roxbury, Mass., and houses in New York, Boston, Philadelphia, Cincinnati, St. Louis and Chicago, the Dennison Mfg. Co. is in a position to supply its customers at the shortest notice with any of their almost infinite array of jewelry boxes, cases for silver and other purposes, and jewelers' findings, in the manufacture of which the company is the oldest house in the country. The semi-centennial of the



J. F. TALBOT.

house, commemorating 50 years of activity in the business world, was fitly celebrated Jan. 1 last by distributing among the employes a fund set apart by the stockholders for this purpose, each employe receiving a gift of \$5 for each year's service with the house. The amount distributed ran from \$5 to \$150 and aggregated over \$20,000. This not only showed a high appreciation of the services of the assistants in their devotion to the company's interests, but serves to illustrate the liberal business principles of the house in dealing with their fellow men.

In 1878 the company was incorporated, and now has a capital of \$1,000,000. In 1868 the Chicago branch was opened by Henry B. Dennison, eldest son of the founder of the business, the late E. W. Dennison. Charles E. Benson succeeded Mr. Dennison at the Chicago salesrooms in 1869, and continued in that position until his death in 1886. In J. F. Talbot, who succeeded to the position thus made vacant, the house has a tireless worker who combines with energetic will power a conservative business judgment that has done much to promote the interests of the house in the west. Mr. Talbot, now a director of the company, was early in life an employe of the house in Boston; was later transferred to Chicago, then to St. Louis, where in 1876 he was made manager, and in his present duties has reached one of the topmost rungs of the ladder of commercial life. The catalogue issued by the house is replete with articles every jeweler needs and is worthy careful perusal.

### The Geneva Optical Co.'s Extensive and Growing Business.

THE Geneva Optical Co. was organized 20 years ago in Geneva, N. Y., by A. L. Smith, and associated with him at that time were some of the present stockholders. A factory was established in Linden St., for the manufacture of gold and steel spectacle and eyeglass frames and other optical appliances of that class. As the business increased wings and additions to the factory were built till space could not be secured for the necessary works. Two years ago the company built a large new factory one-quarter of a mile west of the former building, capable of employing a full force of workmen, and while retaining the old factory for the manufacture of trial cases and goods in that special line, the entire capacity of the new building was given to the production of frames.

From time to time, as the necessity arose, the company has had constructed for it special machinery to perform special work, and has now a plant combining all the latest improvements, unexcelled by any factory in the world. Having visited the western trade, the Geneva Optical Co. felt the need of a western branch to be in closer touch with that section, and in 1889 organized a company in Chicago, financially separate from the parent factory and designed to be a distributing point not only for the product of the factory, but also for the manufactures of other factories, goods of its own make in Chicago and foreign importations. A. L. Smith and J. T. Brayton came west upon the organization of the company here. Mr. Brayton is not only the patentee of the firm's lens measure but has been instrumental in producing many of the improvements which the company has placed upon the market.

In 1889 the Geneva Optical Co. was located at 57 Washington St. It soon outgrew its quarters and moved to 23 Washington St., where it continued in business until the new Marshall Field building was projected to occupy that site, when the company received a bonus for its lease and moved to 67-69 Washington St. In these, its present quarters, the work rooms have been much enlarged; the prescription department alone employing continually at the present time from 25 to 35 workmen. With its unusual facilities the company is prepared to secure all special order or prescription work promptly, the work going out the same day the order is received. A specialty is made of the prescription work, in which department the company is justly proud; also the manufacture of trial cases, lens-measuring instruments, instruments for diagnosing errors of refraction, and fine spectacle and eyeglass frames. The company's trade extends throughout the world, a shipment recently being sent to a point 1,000 miles in the interior of China. Pak Yong Kiu, connected with the Korean Embassy, has ordered goods for Corea, and

shipments to the Gold Coast may be mentioned as a case of carrying the war into Africa. The results of its pronounced successes at the World's Fair have opened to the company the markets of the world.

### Lyon & Healy's Moorish Palace of Music.

THE palace of the Moorish kings, the famed Alhambra, with its riches of ornamentation, is recalled to mind as one enters the grand entrance to the music palace of Lyon & Healy, southeast corner of Wabash Ave. and Adams St., Chicago. The bold and aggressive policy which has always characterized the management of the house in the past is mirrored in the fitting up and arrangement of their Wabash Ave. temple, and the effect produced is a brilliancy not surpassed if indeed it be equaled by the famous galleries of the old world. A jeweler's visit to this latest of Chicago's trade palaces will be a pleasure, not only by reason of the infinite variety of musical instruments presented for inspection but also for the artistic manner in which they are displayed. Whatever he may desire the facilities for purchase are equally pleasing.

The entire depth of the store has been spanned with graceful Moorish arches which form the fronts of as many smaller stores, each of which has been converted into the most captivating of pavilions. These are occupied respectively by guitars and mandolins, banjos and zithers, old violins, cellos and double basses, Lyon & Healy harps, Æolian, music boxes for which two pavilions are required, and a host of band and miscellaneous instruments. Of special interest to jewelers will be an inspection of the fine lines of music boxes, string instruments, and musical novelties, of which the firm are the largest manufacturers in the country, turning out at their West Side factories upward of 100,000 instruments annually.

Throughout the six floors of the building fanciful bits of architecture and arrangement are to be found, which form an artistic setting to the varied productions of the factory. The firm do a large business with jewelers in all sections of the country and are members of the Chicago Jewelers' Association, J. P. Byrnes, secretary and treasurer of the company, being also the secretary of the banquet committee of the association, to whose efforts was due in large measure the credit for the enjoyment had by the jewelers and their friends at the ever-memorable banquet of 1895.

### The Variety of Wares of the Holmes & Edwards Silver. Co.

STERLING silver inlaid spoons and forks, and gold and silver-plated table flatware; also 18 per cent. nickel-silver flatware blankets for plating, are specialties with the Holmes & Edwards Silver Co., with factory at Bridgeport, Conn., and

# BENJ. ALLEN & Co.,

## 141 & 143 State Street,

### Chicago, Ill.

PUBLISHERS OF THE B. A. & CO. JEWELRY CATALOGUE.

Watches, Clocks, Diamonds,  
Silverware and Optical  
Goods,

AT WHOLESALE ONLY.

LOWEST PRICES.  
BEST GOODS.

PROMPT ATTENTION.

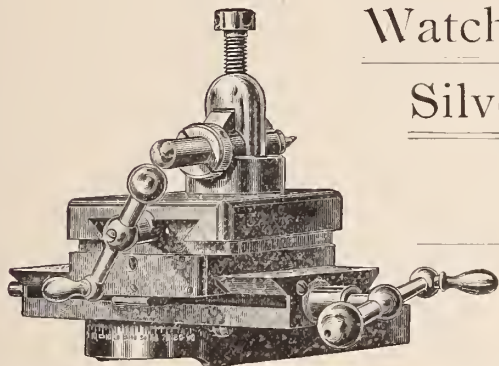

Slide Rest to fit 1x2 Mosely Lathe, - - - \$12.00  
" " " No. 2 " " - - - 13.50  
" " " Geneva Lathe, - - - 12.00

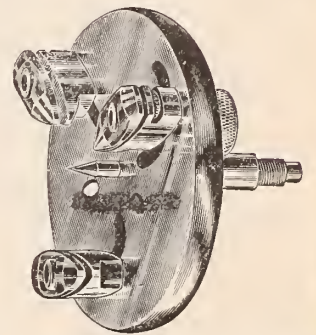

Houghten Universal Face Plate,  
to fit any American Lathe, \$8.00



Watchmakers' Stool, with iron frame  
and leather seat, - - - - - \$5.00

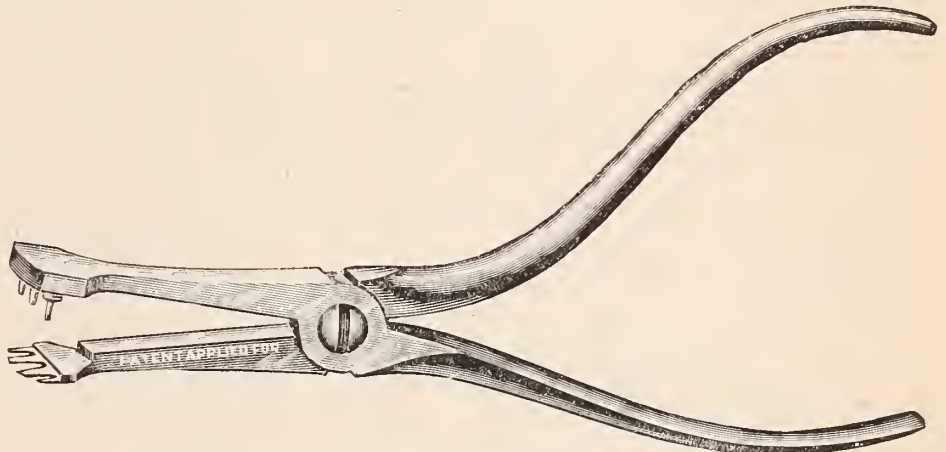

Nickel Plated Hand Removing Plier, - - - - - \$1.00

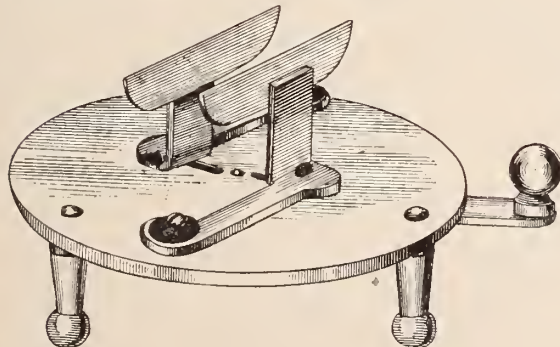

New Style Nickel Plated Poising Tool, - - - \$2.00

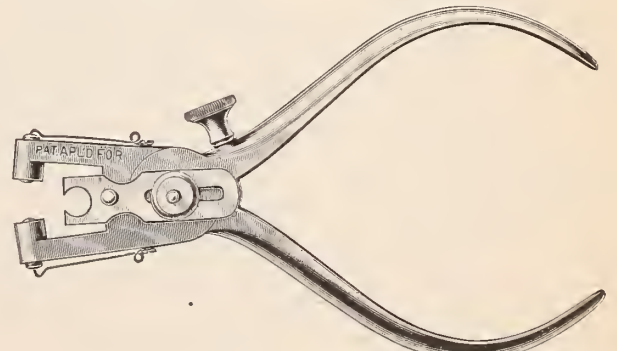

Nickel Plated Combination Caliper and Plier, the latest and  
best, - - - - - each, \$3.50

Six Per Cent. off for Cash.

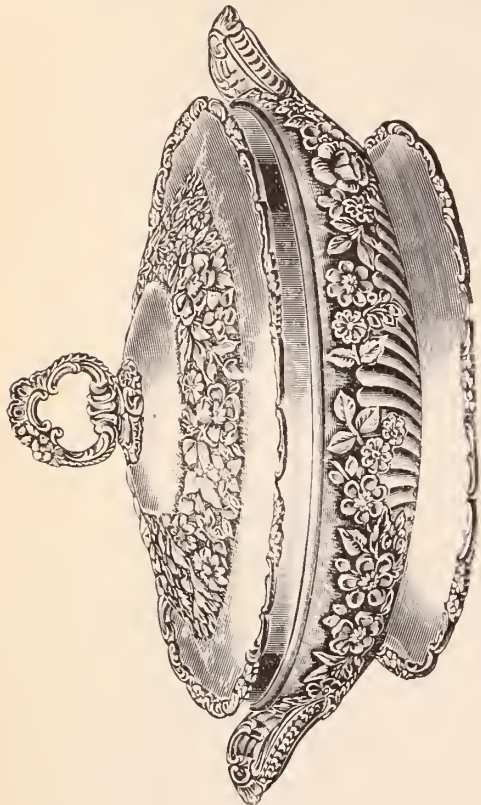

No. 2234, Embossed Baking Dish.

Eight inch, Three Pints, - - - List, \$27.00  
 Nine inch, Four Pints, - - - List, 28.00



No. 1830, Embossed Tureen. Oval.

Two Quarts, - - - List, \$26.50  
 Three Quarts, - - - List, 34.50

THIS IS THE TOP NOTCH OF RICH AND THOROUGHLY ARTISTIC HEAVILY EMBOSSED QUADRUPLE SILVER PLATE. OUTSIDE OF SOLID SILVER, THERE IS NOTHING MADE THAT IS FINER.

# THE MERIDEN SILVER PLATE CO.,

133 & 135 WABASH AVENUE,

FACTORIES:  
 MERIDEN, CONN.

CHICAGO.

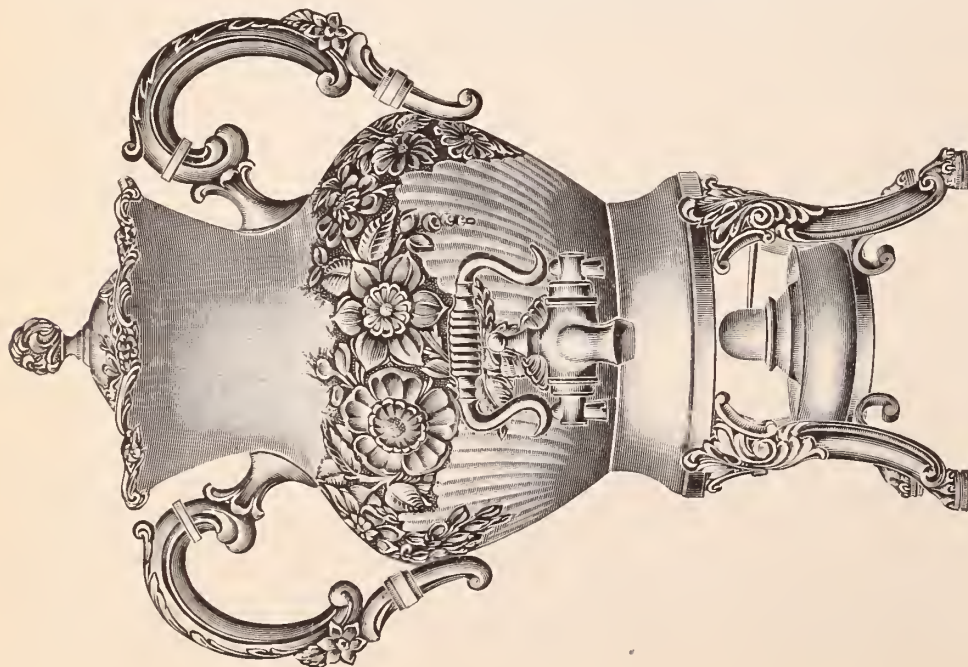

No. 1447, Embossed Urn.

List, - - - \$35.00

We have the Entire Set of Tea Ware (EVERY PIECE AN EX-AMPLE OF HIGH CLASS ART WORK), to match the three pieces here shown, viz:

- Coffee Pot, Tea Pot, Water Pot, Sugar, Cream Gold Lined, Slop
- Gold Lined, Spoon Gold Lined, Butter, Syrup
- with plate, Kettle.

salesrooms at 2 Maiden Lane, New York; 63-65 Washington St., Chicago; 307 N. 4th St., St. Louis, and 120 Sutter St., San Francisco.

The company manufacture all grades of tableware, including solid silver, but as a specialty they have patents on what they term the sterling silver inlaid goods, the method of manufacture consisting of five stages. First, a blank for a fork is milled out at all wearing points. Into these milled out points sheets of pure silver are laid and fused into the blank by means of intense heat. After the milling is filled with the silver the tines are cut out which forms the third stage. In the fourth stage comes the fork in form, ready to buff and plate, covering the places where the sterling silver is inlaid. The same method is carried out with other flatware. A spoon cut through shows that the sterling silver has completely amalgamated with the nickel silver. By this process it is claimed five times as much silver is required for standard plate and that it is impossible for the spoons or forks to show any wear whatever; they are guaranteed for twenty-five years.

In patterns are shown the "Jack Rose," showing hand engraved handles of Jack roses with bowls and blades of differing ornamentation; the "Minnehaha," an ornamental bright pattern of conventional design; the "Hiawatha," a flower pattern completely covering the handles, with hand engraved bowls; the "Triumph," a bright and attractive ornamental scroll and shield pattern; and the "Waldorf," their latest, the handle bordered with small scroll and terminating in neat fluted tip. In plated ware, of many patterns, the "Rialto" and "Delsarte" are especially good. The former shows a polished shield with heavy scroll covering handle; the latter a handle with neat scroll edging.

Something entirely new, issued the first of December, is their "Gold Aluminum" ware. This is made into spoons, forks and smaller fancy pieces, from an extremely pure and perfectly solid metal called "Gold Aluminum." They are free from any trace of the baser metal used in high class plated ware, and having no plating they will never wear nor lose their beautiful color. They have the best of sanitary qualities and are tough as steel, being practically unbreakable. They are quickly cleaned by the ordinary means and retain their polish with much less care than sterling silver. These come in Rialto pattern only.

Everyone knows, or knows of, Peter L. Krider, of Philadelphia, a judge of silverware at the World's Exposition. The following is his report:

"The progress made by the Holmes & Edwards Silver Co. in the manufacture of spoons and forks, is a surprise to me. I have been a practical silversmith for nearly 50 years and familiar with all makes of silver plated flatware. I have seen nothing to compare with, or equal to, their sterling silver inlaid spoons and forks, and believe for hotels and restaurants, as well as family service, they are the most durable goods made."

The World's Columbian Exposition of 1893 gave the company five awards: Most

marked progress, the insurance of durability heretofore unknown, highest grade of materials, finest workmanship and finish, artistic display. With this record the company invite an inspection by dealers.

The factory has a capacity of 200 gross of spoons daily. George E. Edwards is president and treasurer; John Cummings, secretary. T. R. Barnes looks after the interests of the company in Chicago territory, W. W. Brown assisting with a full complement of aides.

**The Products of the Manhattan Silver Plate Co.**

THE volume of new goods shown by the Manhattan Silver Plate Co., at their Chicago house, 63-65 Washington St., is simply astonishing. Starting over 30 years ago in Brooklyn, N. Y., in 1882, the entire plant was removed to Lyons, N. Y., and as increased business has necessitated, has added to machinery and equipment, until, judging from the products of the factory, the capacity at the present time is limited only by the requirements of the trade. The house has rapidly forged to the front and to-day shows a handsome line of quadruple plated white metal hollow ware in desirable sellers—one that appeals to both eye and purse, and commends itself to the retail trade.

In satin finished and bright cut

work the factory is especially fortunate in satisfying public taste. In silver pie baking dishes is shown a plate of granite ware in which the baking is done, with an outer silver plate in which the inner plate is placed on the dining table. New things are shown in a beautiful line of berry dishes in all finishes of silver and colored glaze glass. Novelties there are in bonbons in plain and bright cut gilt, and new designs in bread trays in plain satin, satin bright cut, and chased. Cake baskets are there in plenty in new designs; a pretty line of fern dishes at a low price; a nice line of new pickles with decorated and plain ruby glasses and four choice things in tea sets are of special interest in new goods.

Under the efficient management of its present officers, president O. F. Thomas and secretary G. W. Hill, the company have come to the front with a line that demands the consideration of the retailer. Salesrooms of the company are located at 23 John St., New York; 63-65 Washington St., Chicago; 40 N. 6th St., Philadelphia; 509 Chestnut St., St. Louis; 110 Sutter St., San Francisco. The Chicago salesrooms are in charge of manager T. R. Barnes, formerly St. Louis manager for the company, ably aided by Willis W. Brown, assistant manager. Both gentlemen will take pleasure in introducing the trade to a further acquaintance with the new wares issued by the factory from time to time.

PINS

CHARMS

**Irons & Russell,**  
 Successors to  
**CHAS. F. IRONS.**

**EMBLEMS.**  
 Solid Gold—Rolled Plate.  
 102 Friendship Street,  
 Providence, R. I.  
CHAS. F. IRONS. CHAS. A. RUSSELL.

SOLID GOLD RINGS.

The World's Columbian Exposition of 1893 gave the company five awards: Most

### Story of the Rise of Benj. Allen & Co.

A concise history of the continuous rise and progress of so great a mercantile establishment as Benj. Allen & Co., dating its birth from the infancy of Chicago, is subject matter of peculiar interest to the trade as showing the magnitude to which a business house rightly conducted may acquire; and in this respect it is not without its value to those who seek, in emulation of higher methods, a means leading toward success.

In the many business changes of recent decades there are comparatively few now in the trade who remember the establishment in Chicago in 1864 of the jobbing

jewelry house of M. T. Quimby & Co., owned by Boston jewelers. Located in those days in unpretentious quarters on Lake St., opposite the old Tremont House, the firm four years later were changed to Quimby, Stark & Co., in which Benj. Allen took an interest, Mr. Allen having engaged with the firm in 1865. In 1870 Mr. Stark purchased the interests of Mr. Quimby in the firm, which then became Stark & Allen. This firm were burned out in the great Chicago fire of Oct. 9, 1871, and they with characteristic enterprise secured temporary quarters in the northernmost building left by the flames, a two-story frame structure on Wabash Ave. and Harrison St. For six months during the rebuilding of the city,

the firm occupied these temporary quarters and in 1872, 22 years ago, moved to 137, 139, 141 and 143 State St., where they have remained ever since.

In the same year (1872) Mr. Allen purchased his partner's interest and established



BENJ. ALLEN.

the name of Benj. Allen & Co., the title seemingly being a trade convenience only, as for 22 years the firm has continued without change under Mr. Allen's sole ownership and direct control. Under his management the progress has been rapid. The volume of business has increased five-fold over that of 1872, and in the one month of December in recent years the house has sold more goods than in any full year from 1868 to 1872.

Early in their history the firm made a prominent specialty of Swiss watches. Since then the Swiss demand has fallen to only nominal while the American sales have increased to magnificent proportions, the firm of Benj. Allen & Co., standing in the foremost rank as distributors of American watches. The jewelry department of the firm which constitutes a most important feature, is a reflex of the business policy adopted in the other various departments. Each branch is in charge of men who have been with the house many years, one of them since 1868,—men thoroughly qualified for the positions and excellent judges of the needs of the trade. In jewelry as in all lines carried, the firm are fully abreast of the times and make dominant the special features of latest styles and best quality. The firm make a point of proving the quality of goods by sending samples to the United States Assay Office and having them melted up and officially tested. This is made possible by the large purchases made by the firm.

Watch tools and materials were added as a department in 1881 by the purchase of the business of John H. Mather, who gave his services to the house as manager of this branch. The department is noted for its promptness in filling orders and the good quantity of the material sold. Since June 1 last, the sales in this department have been phenomenal. The firm have never

# FREE

A TRADE = BRINGING  
WINDOW SIGN, SEE  
BELOW. = = = =

Important to all Wide Awake Dealers in Musical Instruments,  
Musical Sundries, Strings, Musical Novelties, Etc., Etc.

**O**UR New Musical Merchandise Catalogue, 380 pages, is now ready for distribution. It is the most exhaustive work of the kind ever issued. It contains New Musical Trimmings, Assortments, String Assortment, Violin Outfits and many other goods that admit of splendid profits.

IF YOU WOULD LIKE A COPY (GRATIS), KINDLY LET US HEAR FROM YOU WITHOUT DELAY.

ADDRESS ADVERTISING MANAGER

## LYON & HEALY,

Cor. Wabash Av' & Adams St., - - - CHICAGO.

N. B.—Free, with orders for goods—a beautiful sign reading:

**STRINGS** Violin, Guitar,  
Mandolin, Banjo.

The Kozie Flakie Strings are the best!

\*OR WILL BE SENT SEPARATELY ON RECEIPT OF 3  
CENTS TO DEFRAY POSTAGE.



before approached in their orders, for the season, those they are now filling for all sections of the country, the frequent orders from Pennsylvania and New York State being particularly noticeable. Canada, Mexico and South America are also well represented in the orders. As an addendum to this department the optical stock of John H. Mather was purchased, the line as at present carried requiring 68 pages of the general catalogue issued by the company.

The firm have established connections in Amsterdam with the very best cutters and those having the largest facilities, and are direct importers. The clock and silverware departments are in charge of competent men thoroughly experienced in their respective lines, and the sales in both departments have kept pace with the general growth of the company's business. In clocks they are western agents for the popular line of the E. Ingraham clocks. In the flatware branch of the silver department a specialty is made of ★Rogers & Bro. A1. goods. Sales of hollowware comprise the well known lines of Homan & Co., Simpson, Hall, Miller & Co., and Pairpoint Mfg. Co.

The company issue a general catalogue of all lines carried, a handsome volume of 768 pages, and a tool and material catalogue of 464 pages, each the foremost of its kind; and covering as they do all goods required by the retailer, are of great assistance in ordering. These are sent to dealers only

who are entitled to them, as the interests of the firm and their customers are of sufficient magnitude to make it to their interest to protect the legitimate trade. These customers number many who have dealt with the company since they first entered business. In all that goes to make a leading business house the firm of Benj. Allen & Co. are pre-eminent.

**The Principles of Business of Glickauf & Newhouse.**

**R-E-L-I-A-B-I-L-I-T-Y** is the way Glickauf & Newhouse spell the word, and when reliability in watch tools and materi-

in its completion, that imitation or inferior goods have been forwarded to fill his order, or perhaps a substitution of something else for the article ordered. In the prompt and proper filling of orders intrusted to them lies the secret of much of the success the firm have well merited. Substitution is avoided by Glickauf & Newhouse under all circumstances, and there is no necessity for substitution, for their large and well filled storerooms show a stock complete to the minutest requirement, a stock that obviates all necessity under ordinary circumstances of going outside their own sales and stock rooms in filling orders. In connection with their promptness and accuracy in busines



MR. GLICKAUF.



MR. NEWHOUSE.

als is to be considered, the firm are an authority. There is nothing more provoking to a jeweler than to find, after holding a job and ordering the material to be used

dealing the rule of the house to handle reliable goods only is a consideration well worthy the commendation of all watch-makers.

# LÉON J. GLAENZER & Co.,

80 and 82 Chambers St., New York.



## Clocks, Bronzes, Lamps,

Fine Decorated Porcelains and Glassware.

Decorated China Toilet Articles.

Onyx Pedestals and Tables, Bric-a-Brac Cabinets.

All French and German Potteries.

NOVELTIES AND SPECIALTIES FOR THE SPRING TRADE. NEW SAMPLES FOR IMPORT ORDERS NOW READY.

The firm originally established themselves in San Francisco in 1875. Successful from the start, they saw even greater opportunities in a more central location, where the larger proportion of the trade might be served more promptly and sold their flourishing business on the coast, coming to Chicago. This was 15 years ago. The business qualifications of Messrs. Glickauf and Newhouse were eminently suited to this larger field, and the growth of their sales from year to year carries with it the conviction that their methods of doing business are based on right principles. With the buying and general supervision in the competent hands of Mr. Glickauf and the sales department in the personal charge of Mr. Newhouse, the rapid strides forward the firm have taken are not to be wondered at. The firm occupy commodious quarters at 86 State St., where they would be pleased to personally meet visitors to the city.

### The Beauty and High Quality of the Meriden Silver Plate Co.'s Wares.

**A**N immense variety of everything in hollow and flat ware and a fine line of cut glass of their own manufacture greets the eye as one enters the salesrooms of the Meriden Silver Plate Co., 133-135 Wabash Ave., Chicago. The wares are attractively arranged on long tables, occupying the central space in the rooms, and deep wall cases for the larger pieces line the walls on both sides. The western branch was established in 1884 to supply an increasing demand from the western, northwestern and southern States. Six years ago the company moved from 64 Washington St., their earliest location here, to their central quarters at 133-135 Wabash Ave.

April 15, 1889, H. H. Walton assumed the duties of manager of the Chicago store. Mr. Walton is a thorough believer in qua-



H. H. WALTON.

lity as regards plated ware, and his position, therefore, at the head of the Meriden Silver Plate Co.'s western interests is a congenial one. The house do not make the trashy grades which now and again flood the market, but confine their efforts to the one purpose of making the best at a reasonable price. And when Manager Walton remarked: "There is nothing nicer made on earth than our hollow ware," he said it with an earnestness that could

not help but carry conviction. Not only in quality, but also in beauty of patterns, the season's production is unusually rich, and betoken's a master hand in the designing department at the factory.

The cut glass department of the company, which has been developed by degrees, has become an important item in their manufactures. This factory, it is understood, was the first silverware factory in the country to cut the glass bottles for their casters, and this gradually developed into a complete plant for the production of cut glass. Of this the company make a nice display at the Chicago salesrooms.

### The Eminent Standing of C. H. Knights & Co.

**T**HE thorough grasp of the principles of business affairs possessed by C. H. Knights, combined with the valuable experience of W. H. Gleason, the two mem-



C. H. KNIGHTS.

bers of the firm of C. H. Knights & Co., are the levers that have aided largely in giving the firm their present prestige in the trade. Schooled in his duties by having risen from the position of order clerk, through that of traveler, to the head of the house bearing his name, Mr. Knights has had instruction in the school of practical experience. Mr. Gleason for many years held responsible positions in the Probate Court and Sheriff's office, having entire charge of the latter office for several years; and the knowledge there gained, as related to credits and accounts, has reduced to a minimum the setbacks with which trade is surrounded.

With two such forces working in conjunction the result could be naught else than a steady growth. The firm carry all lines necessary in conducting the largest jewelry store, but of recent years while still adding to each of their many departments, they have placed their diamond business well in the foreground, and thus, while all the departments have shown increases, the diamond business has become a prominent one. Both partners are men of foresight, and keep closely in touch with trade and legislative affairs, and this oftentimes enables them to give a customer the advantage of a rising or falling market.

This is an important consideration to the retailer, and one which he will not be slow to appreciate.

The trade are extended a cordial invitation to call at C. H. Knights & Co.'s handsome salesrooms on the 3d floor of the Columbus Memorial building, southeast corner State and Washington Sts., and inspect the latest productions of the leading manufacturers.

### Bates & Bacon's Popular Cases.

**A**T 167 Dearborn St., is the Chicago office of Bates & Bacon, where H. S. Noyes carries a full line of the popular B. & B. cases for the convenience of jobbers in Chicago and adjacent cities. The line includes all those good sellers, the Favorite, Royal 14 k., Peer and Puritan. In the Royal 14 k. line which has proved so very popular are the 6 and 0 sized bascine vermicelli and the 16, 6 and 0 sized vermicelli and star. New designs in the Royal 14 k. are being



W. H. GLEASON.

put on the market constantly in order to meet the demand for these popular and valuable goods.

H. S. Noyes, who represents Bates & Bacon in Chicago and nearby territory, is well known to the trade. He was connected with the Brooklyn Watch Case Co. for nineteen years and thoroughly understands the needs of western jobbers. For the past two years he has held his present position with most satisfactory results. The home office of the firm is at 11 John St., New York, under the management of E. R. Crippen.

### A Pushing Firm of Silver Plated Ware Manufacturers in the Western Field.

**T**HE western trade and Chicago jobbers in particular are cordially invited to call at the handsome salesrooms of the Adelphi Silver Plate Co., 34 Monroe St., Chicago, where the resident representative, L. Seligsberger will make visitors welcome. "I am showing one of the finest and most complete lines of silver plated ware ever offered to western buyers," said Mr. Seligsberger. "The goods are of specially excellent appearance, original and

artistic in design, beautifully made, heavily silver plated on hard, white metal, and well finished. The line comprises many new and original ideas and particularly worthy of mention is the line of eastern novelties, all salable and pleasing goods. We have a well established eastern business and appreciate the fact that in reaching out for western buyers we must meet the strong competition by means of special inducements. These we offer in the shape of best quality of goods, in original designs, at moderate prices, and in keeping up to the times in the shape of new goods of which we are constant producers. The various members of the company are all practical men of special skill in their various vocations. Hence the saving in the shapes of salaries for designers, foremen, superintendents and managers enables us to offer goods at the closest possible figures. At any rate," concluded Mr. Seligsberger, "I will certainly open the eyes of such western buyers as have not yet seen our line if they will give me a call."

A handsome new illustrated catalogue just issued by the company contains about 150 pages filled with good things. It will be sent on application to any dealer who has not yet received it. The New York office of the Adelphi Silver Plate Co. is at 62 John St., and the factory takes in the buildings, Nos. 124 to 130 Pearl St., Brooklyn, N. Y.

The growth of the company has been so gratifying despite the recent business depression that from May 1st of the present year the present shop room will be doubled, leases having already been signed for the same.

#### The Old Reliable W. & S. B.★ Chains.

THESE goods are always in evidence in Chicago. Sumner Blackinton and Ernest Block cover the territory thoroughly and systematically, and when one bears in mind the quality of goods and the very complete line produced by W. & S. Blackinton, it goes without saying that their order books are always well filled.

#### Foster & Bailey's Large Line of Jewelry.

THE readers of THE CIRCULAR can gain an idea of the scope of this firm's products by their handsome page display else-

where in this issue. Their goods are sellers and up to date. J. A. Limbach is the Chicago representative, located at 167 Dearborn St., and carries a full line of the firm's excellent goods. The main office and factory are at 100 Richmond St., Providence, R. I.

#### Quick Selling Novelties of Codding Bros. & Heilborn.

THIS headline is the watchword of the enterprising firm of Codding Bros. & Heilborn, No. Attleboro, Mass., whose Chicago representative is F. A. Buck, with cosy and comfortable headquarters at 103 State St. Sterling silver novelties of all kinds are shown, and the line will repay inspection.

THE R. Wallace & Sons Mfg. Co., Wallingford, Conn., are ably represented in Chicago by George M. Wallace and at their handsome salesrooms 86 Wabash Avenue, the visitor gets an idea of the fine work capable of production in silver at the hands of experienced artisans. The company's reputation in their field renders any panegyric unnecessary. The exterior of the Chicago office appears in one of the plates in this number.

G. J. COREY, at 224 Wabash Ave., looks after the Chicago interests of the Pairpoint Mfg. Co., New Bedford, Mass., in an excellent manner. The salesrooms of the company are well stocked with a full line of this company's popular and salable goods.

J. K. CALDWELL represents the Rogers & Hamilton Co., Waterbury, Conn., in Chicago. The salesrooms are at 110-112 Wabash Ave. and there will be found a full line of all the company's popular patterns. The Chicago trade is cordially invited to call.

#### The History of O. W. Wallis & Co.

O. W. WALLIS, of O. W. Wallis & Co., is one of the old timers in the Chicago jewelry trade. When the war broke out, having become of age and assumed

the duties of citizenship, he thought it the duty of a citizen to defend his country. Enlisting in a Wisconsin regiment of artillery he served with distinction in the army of the west, being under Grant in the important engagements in Mississippi and Tennessee and siege of Vicksburg. He was promoted to a first lieutenancy for meritorious conduct on the field of battle, and by subsequent gallantry was brevetted captain, and to-day wears the button of the Legion of Honor, the only one in the trade in Chicago. Returning home a short time later, 1866, he engaged in mercantile life in Chicago. His merits were soon recognized, and promotion, as of yore in the army, followed. In 1869 he purchased an interest in the firm of Cogswell & Co. Later the firm name changed to O. W. Wallis & Co., who are ever alert to secure the latest designs of new goods, and their salesrooms at 103 State St., are always open to the inspection of visiting tradesmen, who are assured a cordial welcome.

#### St. Louis.

Chas. L. Bates, of the Mermod & Jaccard Jewelry Co., is lying seriously ill at his home, 4126 Page Ave.

The J. Bolland Co., now two doors south of the southeast corner of 4th and Market Sts., have leased new quarters in the Mercantile Club, at 7th and Locust Sts.

Fred Geitz, jeweler, 418 N. 7th St., whose show case was broken a few days ago and a lot of jewelry stolen, went to O'Fallon, Ill., in order to look at the jewelry which was found in possession of two boys giving the name of Murphy.

H. L. Beard, cashier E. Jaccard Jewelry Co., applied for a warrant a few days ago, against Harry Snyder, Jr., charging him with obtaining a gold ring and \$48 on a bogus check, purporting to have been drawn by his father on the Laclede Bank.

The following officers of the Bauman-Massa Jewelers' Supply Co. have been elected: S. H. Bauman, Edwin Massa and G. H. Moll; and of the St. Louis Clock and Silverware Co.; F. L. Jaccard, S. H. Bauman, Edwin Massa, G. H. Moll and Otto Pfeffer.

# DEITSCH BROTHERS,

MANUFACTURERS OF...



Leather Goods, Tortoise Shell Goods.

Ebony Goods, Sterling Silver Novelties,

7 EAST 17TH STREET,

NEAR UNION SQUARE,

NEW YORK.

### The United States Optical Co. Purchased by the Former Secretary.

DETROIT, Mich., Jan. 22.—The United States Optical Co., in accordance with an advertisement, were sold last Monday and alderman Oscar B. Marx, the former secretary, was the purchaser. He paid \$12,000 for the company. The stock inventoried at \$30,000. Recently the optical company borrowed \$15,000 on a mortgage from Frank Rasch, Charles Ortman, S. G. Miner, and Eugene Deimel. It was this mortgage that Mr. Marx bought for \$12,000. It was then foreclosed and he became the owner of the property.

City Attorney Rasch says the company will be re-organized at once and the business will be continued at the old quarters on Miami Ave. The building is not yet completed, but as soon as the weather permits, work will be commenced on it.

### Jeweler Rorig, Charged With Keeping a Fence, Released on Bail.

EDWARDSVILLE, Mo., Jan. 25.—John P. Rorig, jeweler, indicted by the grand jury several weeks ago for receiving stolen goods, or acting as a fence for local burglars, has been released on bond. His father, who resides in Wisconsin, made a deposit of \$1,000 in John A. Prickett & Sons' bank to secure the bondsmen for that amount.

Rorig's attorneys have been persistent in their efforts to have the prisoner re-

leased, and this proved the only method, as the sentiment at home was not favorable to him.

### The Death of Joseph Russell.

LOUISVILLE, Ky., Jan. 22.—Joseph Russell, one of the best known watchmakers and jewelers in the city, died at 6 o'clock P. M. Jan. 17<sup>th</sup> at the St. Joseph's Infirmary at the advanced age of 81 years. Mr. Russell, previous to his retirement from business a few years ago, had charge of the watch department of George Wolf & Co. Before that he conducted a jewelry store at Bardstown.

Three sons survive the deceased: A. R. Russell, a jeweler of Bardstown; Capt. Ed. M. Russell, ex-marshal of Springfield; and J. S. Russell, jeweler and city marshal of Taylorsville. The body was shipped to Bardstown for burial.

### N. B. Jeter, Butler, Mo., Sues a Rival Jeweler for \$60,000.

BUTLER, Mo., Jan. 24.—N. B. Jeter, jeweler, has sued F. Bernhardt, a rival jeweler, for \$10,000 on each of six counts for libel. The suit is based on a circular issued by Bernhardt during the holidays, which contained the following: "I cannot compete selling cheap diamonds, as I do not take the ladies' \$300 diamonds out of their earrings and substitute paste diamonds, as has been done."

The petition states that the defendant, in explanation of this paragraph, said that Jeter took the earrings of one, Mrs. Walton, and substituted paste diamonds worth about \$30.

### A. B. Kapp Offers to Settle With His Creditors.

PROVIDENCE, R. I., Jan. 20.—Albert B. Kapp, who owes 40 or 50 local concerns various sums of money, and who, last month was refused the privilege of taking the poor debtor's oath, has made an offer of settlement with his creditors. He has offered 25 cents on the dollar, which sum the creditors have generally refused. They are of the opinion that in time they will be able to secure every cent due them. In the meanwhile Kapp is out of the State on bail to the amount of about \$10,000, and this commonwealth has ceased receiving big board money. When confined at the jail in Cranston each creditor paid \$3 per week for his board, and as there was 42 creditors, the New Yorker was styled a "gilt-edged" sort of a boarder.

A number of cases came up in the Sixth District Court, last Monday, in the civil branch, before Judge Cooke. They were none of them tried, however, the defence putting in no evidence, but submitting to judgment. Writs of execution will now be drawn up and placed in the hands of a sheriff for service. That official will then inaugurate a hunt after Mr. Kapp. The

# J. W. RICHARDSON & Co.

200 Broadway, NEW YORK.



TRADE MARK



MANUFACTURERS OF



TRADE MARK.

## SOLID GOLD EMBLEMS, Charms, Pins and Lapel Buttons.

Ask your Jobber to show you his "Blue Book" of Emblems for 1895.

# THE VALUE OF THE JEWELERS' CIRCULAR,

..... AS EXPRESSED IN .....

## UNSOLICITED TESTIMONIALS.

The following unsolicited expressions of opinion were recently received:

### REGARDING THE JEWELERS' CIRCULAR.

Enclosed find \$2 for another year's subscription to your valuable journal. Long live THE JEWELERS' CIRCULAR is the wish of  
CHAS. TUCKER, Del Norte, Cal.

As soon as our subscription is out, we shall renew it. We shall take THE CIRCULAR as long as we are in business.

MARKS & KRANK, Schenectady, N. Y.

I am *well pleased* with THE CIRCULAR and no man in this business can afford to be without it.

H. A. ANSTEAD, Massena, N. Y.

I would feel lost without THE CIRCULAR for it is the Heart of the jewelry trade.

S. E. WILLIAMS, Gloversville, N. Y.

THE CIRCULAR has been visiting me monthly and weekly for the past 18 years.

H. H. ROBINSON, Presque Isle, Que.

It is *the* live jewelers' paper and keeps us in touch with the trade throughout the continent. We want it if only for the advertisements.

BRITTON BROS., Lindsay, Ontario.

We think it pays to keep posted. We read our CIRCULAR and find it to be one of our very useful helps.

BROWN, HIXON & Co., Lockport, N. Y.

It is the *Best* paper on the market and one cannot be without it.

R. J. TRUMBULL, What Cheer, Ia.

THE CIRCULAR has been the means of saving me considerable money in the last three years in buying goods from jewelers who advertise in it.

H. M. TURNEY, Goodland, Kan.

I always find THE CIRCULAR very interesting, and find many points of information in the same which have often proved to be quite valuable to me.

A. E. HAHN, Westerly, R. I.

Think each article you publish about "Window Decoration" worth the full price of your subscription, and trust you will have more of them this year.

GEO. E. FEAGANS,

Joliet, Ill.

### REGARDING "WORKSHOP NOTES."

Workshop Notes received and am well pleased with it. I think every watchmaker should have one, for there are points that could improve their knowledge. I recommend it very highly.

S. E. WILLIAMS,

Gloversville, N. Y.

I received my copy of Workshop Notes last night and am very much pleased with same.

H. W. SELTS, Clay Center, Kan.

Your Workshop Notes is a valuable book of reference and all watch makers and jewelers should have a copy.

FRANK P. MCKENNEY, Portland, Me.

I received my copy of Workshop Notes and I am very much pleased with it.

E. H. HAYWARD, Ballston, N. Y.

More than pleased with the Workshop Notes.

C. W. BLAKE, Baltimore, Md.

Will say that I think Workshop Notes will be very handy and helpful to any one as a watch maker and jeweler,

D. L. CLEELAND, Butler, Pa.

I also wish to add my testimony to the value of "Workshop Notes." It is a book brim full of facts which cannot fail to be of great value to the workman. I have tested its value for a year past and I find it a valuable book.

J. H. HARMON, Bolivar, N. Y.

### REGARDING THE CIRCULAR'S SPECIAL NOTICE PAGE.

We are very much indebted to THE JEWELERS' CIRCULAR through whose columns we secured our very competent watchmaker and optician now in our employ.

C. H. ANKENY Co., Lafayette, Ind.

We are very well satisfied with the results of our ad. and think we can be suited.

JAS. D. LEYS,

Butte, Mon.

Must say we got excellent returns from the little ad. showing plainly that your medium is read far and wide.

S. JACOBS & Co.,

Minneapolis, Minn.

THE JEWELERS' CIRCULAR IS A COMPENDIUM OF NEWS, TECHNICAL INSTRUCTION AND VALUABLE SUGGESTIONS FOR THE CONDUCTING OF A JEWELRY BUSINESS.

## Our Traveling Representatives

Traveling representatives may consider these columns open for the publication of any news or items of interest regarding themselves or their confreres.

**C.** G. Megrue is on his trip through the west in the interests of Aikin, Lambert & Co. A. S. Reilly and M. F. Thornton, also with this house, will soon commence to cover their respective territories. J. H. Jenkins, in charge of the Chicago branch of Aikin, Lambert & Co., will visit during the season his customers throughout the north-west.

L. I. Beckwith will represent the Rockford Watch Co. in New York State and Connecticut.

J. J. Rolleston, who recently severed his connection with Aikin, Lambert & Co., New York, is now with Jno. W. Reddall & Co., Newark, N. J.

C. Eugene Bahm will represent the material house of H. B. Peters & Co., New York, through Pennsylvania, Maryland and the south. Louis Berger will also represent the firm through New York and New England.

Among the knights of the grip in Columbus, O., recently were: J. M. Morrow, American Watch Case Co.; Charles W. Hempel, Sandland, Capron & Co.; H. A. Tibballs, Wilcox Silver Plate Co.; John R. Jepson, Byron L. Strasburger & Co.; T. D. Munson, Wm. Rogers Mfg. Co.; M. Stein, Wendell Mfg. Co.

Among the traveling salesmen in Wilmington, Del., last week were: Fred. Crane, Mandeville, Carrow & Crane; Thos. E. Rogers, Hayes Bros.; Mr. Steel, Maltby, Henley & Co.; Jos. Halbertstadt, S. Kind & Co., E. H. Pelletreau, Shafer & Douglas; J. Hooper, Simons, Bro. & Co.

Among the travelers visiting the Hub the past week were: Walter Gardner, L. Wilcox & Co.; Harry Barrows, H. F. Barrows & Co.; Mr. Marsh, C. A. Marsh & Co.; Mr. Freeman, B. S. Freeman & Co.; Charles Bennett, Jacob Bennett & Son; Herbert Slater, Champenois & Co.; Arthur Simons, Stern Bros. & Co.; Eugene H. Cox, Sussfeld, Lorsch & Co.; W. D. Elcox, Larter, Elcox & Co.; A. L. Stearns, Roy Watch Case Co.

Traveling salesmen passed through Detroit in swarms last week. Many chain men were present. Among those who visited the trade were: Chas. F. Ketcham, Riker Bros.; Mr. Lucas, Bliss & Co. and J. G. Cheever & Co.; W. D. Port, Coddling Bros. & Heilborn; Sam. Kohn, Renommee Mfg. Co.; Mr. Carpenter, the Parsons & Greene Co.; Harry Osborne, Whiting Mfg.

Co.; J. H. Granbery, Reeves & Sillocks; Mr. Darling, J. W. Pierce & Co.; Mr. Lee, W. E. Webster & Co.; J. E. Alexander, for Frank W. Smith; F. H. Carpenter, Alfred H. Smith & Co.; Mr. Jacobs, Providence Stock Co.; J. M. Fisher, J. M. Fisher & Co.; Mr. Barry, A. Bushee & Co.; L. Seligsberger, Adelphi Silver Plate Co.; Mr. Richardson, G. A. Dean & Co. and Mr. Waterman, Pairpoint Mfg. Co.

Traveling men in Pittsburgh, Pa., during the past week were: Mr. Whitney, S. E. Fisher & Co.; Mr. Steele, J. B. Bowden & Co.; C. J. Suplee, Belknap, Johnson & Powell; C. W. Cary, J. B. & S. M. Knowles Co.; C. A. Boynton, Wm. B. Kerr & Co.; Mr. Hasberg, Lazarus, Rosenfeld & Lehmann; Mr. Crane, Strobell & Crane; Lawrence H. Smith, Bipart & Co.; Wm. Peacock, French & Franklin Mfg. Co.; L. V. Benson, for Frank H. LaPierre; A. D. Miller, Pairpoint Mfg. Co.; Fred. L. Baker, Hayden W. Wheeler & Co.; A. B. Daggett, Derby Silver Co.; Mr. Hudson, H. F. Barrows & Co.; Mr. Sheridan, Horton, Angell & Co.; C. C. Darling, L. W. Pierce & Co.; Arthur Bradshaw, Meriden Britannia Co.; M. L. Jacoby, Providence Stock Co.; C. O. E. Hartung, Sussfeld, Lorsch & Co.; Charles W. Hempel Sandland, Capron & Co.; Tom J. Hutson, Spencer Optical Mfg. Co.; F. S. Sherry, Joseph Fahys & Co.; Fred. J. Foster, Unger Bros.; S. L. Barbour, Barbour Silver Co.; Mr. Sommer, Thos. Totten & Co.; John Lamb, T. I. Smith & Co.

### COMMERCIAL TRAVELERS' CLUB SMOKER.

There were but few if any of the host of knights of the gripsack who thronged the parlors of the Commercial Travelers' Club, 15 W. 31st St., New York, Friday evening, who did not agree that the "smoker" on this occasion was one of the most enjoyable ever held by the club. Even more than the usual array of "talent" was present to contribute to the enjoyment of the evening which was accentuated by the collation washed down with famous C. T. punch. Among the many favorites were "musical director" Powers, Miss Arnold, of the Monte Carlo Co., Mr. Raines whose fine voice the audience could not hear too much of, and many others. Tom Ballantyne as usual set the travelers roaring with laughter with his quaint recitations and humorous stories, but the event of the evening followed when piquant Julia Mackay sang "I Don't Want To Play In Your Yard," and "Her Golden Hair Was Hanging Down Her Back." The audience almost went wild in their enthusiasm, applauding her again and again. The "boys" departed in the wee hours of Saturday morning, unanimous in the feeling that a glorious time had been passed.

We again call attention to the Czarina buckle collarettes and stick pins, and the enamelled shields as offered by Geo. F. Greene & Co., Providence, R. I. The goods are finished in silver and Roman, of beautiful design and at remarkably low prices.

### Last Week's Arrivals.

**THE CIRCULAR** has perfected arrangements for obtaining the names and hotel addresses of all the latest buyers visiting New York, and each day posts in its office, 189 Broadway, a bulletin which every member of the trade is cordially invited to copy.

The following out-of-town dealers were registered in New York during the past week: H. M. Eliasoff, Albany, N. Y., H. Imperial; A. Rosenstein, Lancaster, Pa., Grand H.; W. B. Page, Boston, Mass., Astor H.; T. F. Christie, buyer for J. G. Myers, Albany, N. Y., St. Cloud H.; A. C. Anderson, Toronto, Ont., Astor H.; A. S. Stone, Chicago, Ill., Grand Union H.; W. L. Ballou, Providence, R. I., Murray Hill H.; H. E. Hall, buyer for Forbes & Wallace, Boston, Mass., Murray Hill H.; G. M. Gibbs, buyer for M. E. Smith & Co., Omaha, Neb., 338 Broadway, New York; H. L. Houghton, Boston, Mass., Astor H.; J. B. Lippincott, Philadelphia, Pa.; Oriental H.; J. Karr, Washington, D. C., Gilsey H.; J. B. Norris, Chicago, Ill., Astor H.; W. A. Gill, St. Louis, Mo., St. Denis H.; J. F. Beyerle, Reading, Pa., Sturtevant H.; H. C. Tilden, Providence, K. I.; Murray Hill H.; G. J. Titus, Chicago, Ill., St. Cloud H.; J. A. Anderton, Dayton, O., Imperial H.; A. A. McCandless, Pittsburgh, Pa., Imperial H.; J. F. Morrill, Boston, Mass., St. Denis, H.; L. and E. Sickles, Philadelphia, Pa., Astor H.; J. K. Roumaine, Baton Rouge, La., Astor H.; E. G. Forman, Chicago, Ill., Holland H.; J. A. Pitt, Montreal, Que., Amsterdam H.; A. Kingsbacher, Pittsburg, Pa., Astor H.; C. G. Bigelow, Boston, Mass., Sturtevant H.; B. Allen, Chicago, Ill., Hoffman H.; H. F. Hahn, Chicago, Ill., Hoffman H.; B. Allen, Chicago, Ill., H. Waldorf; L. W. Flershem, Chicago, Ill., H. Waldorf; H. F. Hahn, Chicago, Ill., H. Waldorf; A. G. Schwab, Cincinnati, H. Waldorf; A. S. Goodman, Philadelphia, Pa., St. Cloud H.; A. Sickles, Philadelphia, Pa., St. Cloud H.; E. B. McClelland, Syracuse, N. Y., Windsor H.; W. S. Bigelow, Boston, Mass., H. Brunswick; J. G. Crump, Boston, Mass., Morton H.; J. King, Cleveland, O., Union Sq. H.; E. P. Kohn, H. Kohn and G. E. Kohn, Hartford, Conn., Imperial H.; S. L. Abt, Chicago, Ill., Stewart H.; H. Benham, Toronto, Ont., Grand Union H.

At a meeting of the creditors of S. Goodman, New Haven, Conn., held at the office of Herzog, Goldsmith & Frank, 14 Maiden Lane, New York, Monday, Mr. Strouse, attorney for Goodman, made an offer of settlement at 40 cents cash. The notice calling the meeting stated that Goodman's liabilities were about \$34,000 and his assets about \$17,000. Only 10 creditors out of about 70 were present, but among these were some of Goodman's largest merchandise creditors.

**Boston.**

## TRADE CONDITIONS.

Expectations have hardly been met during this first month of the year, a very quiet tone having characterized trade here in the past fortnight. Dealers have not lost their hopefulness for a good year on the whole, but look forward to an improvement when stocktakings are all out of the way and the decks are cleared for action once more.

A Harmon, of the American Waltham Watch Co.'s Montreal office, was in Boston during the week.

President Benton, of the Courvoisier-Wilcox Mfg. Co., was among the visitors to the trade here the past week.

A. A. Abbott, manager of Smith, Patterson & Co.'s Montreal office, has been in the Hub on a short business trip.

Treasurer Arthur M. Little and manager Rufus B. Carr, of the E. Howard Watch & Clock Co., are in New York this week on business and as attendants upon the annual meeting of jobbers.

William S. Brown, who has been bookkeeper and cashier in the Boston office of the E. Howard Watch & Clock Co. during the past six years, and was previous to that time bookkeeper for the concern at the factory in Roxbury, died Jan. 20, at his home in Dorchester, after a brief illness.

He was a man of sterling character, and will be sadly missed by his associates and his many friends in the trade.

E. Frank Wilson has accepted a position in the diamond and watch department of J. A. Foster's establishment, Providence.

At the annual meeting of the directors of the E. Howard Watch & Clock Co. routine business was considered. The annual business meeting of the stockholders will take place Feb. 11th.

Harwood Bros. will occupy the space in their store just vacated by Charles May, who takes a convenient room on the same floor. Harwood Bros. will devote their extra space to their optical department, to a large extent.

An alarm clock and some chains, most of them plated, the entire haul being valued at \$32, were secured early on the morning of January 24 by a thief, who threw a brick through the window of Benjamin DeYoung's store on Kneeland St. and made his escape.

Buyers in town during the week included: H. J. Frost, Springvale, Me.; W. D. Heath, Lockport, N. H.; A. G. Stone, Montpelier, Vt.; H. E. Fay, Keene, N. H.; G. R. S. Killam, Providence, R. I.; Charles T. Davis, North Berwick. Mr. Davis was formerly with L. E. Hanson, of South Berwick, but will start for himself soon, and has been in town stocking up.

During the last 18 months Mrs. Daniel

Falconer has been searching for her husband, whom she married more than 20 years ago when he was doing business in this city and was a man of reputed wealth. It is a case of desertion and hasty flight with another woman. She traced her husband to Duluth where she has sworn out warrants against him. She also attempted taking possession of his jewelry store. Divorce proceedings are now on the tapis.

**Syracuse.**

Harry W. Duncan has given a chattel mortgage for \$1,000.

Samuel Anderson, a peddler, living at 711 Almond St., complained to the police a few days ago that he had been robbed of a satchel containing \$900 worth of jewelry. The man claims that he bought the goods some time ago of I. J. Liberman & Co., and that shortly after Leon Berson, brother-in-law of Liberman, came to his house and took possession of the goods.

Edward Dillon, who was caught last Wednesday noon by bookkeeper G. J. Hall, while attempting to rob the safe of the Crescent mills at Rochester, on Thursday morning acknowledged his identity as "Kid" O'Brien. He waived examination and was held by Police Justice Ernst to await the action of the Grand Jury. His "pal" escaped. The description of Dillon tallies exactly with that of the man who operated last Fall in Utica and Syracuse jewelry stores.

# TWO MINUTES WITH YOU!

## DO YOU APPRECIATE SALABLE GOODS?

Goods that embody artistic ideas, novel conceptions, excellent workmanship and sterling worth?

### OF COURSE YOU DO!

And it gives us pleasure therefore to call your attention to our line.

Among other things that will prove profitable and make your customers better friends than ever, are:

**RINGS**—stone, band, plain, fancy, etc., etc.

**SILVER BELT PINS**—ornate and plain.

**CZARINAS**, in gold or silver, beautiful designs.

**SCARF PINS** in infinite variety.

**LINKS**, in silver or gold, plain, fancy, enameled, etc.

**STICK PINS**, too numerous to detail.

A beautiful line of **RIBBON** and **SEAL FOBS**,

**STUDS, DROPS, Etc., Etc.**

“OUR GOODS SELL.”

# WAITE, THRESHER COMPANY,

## PROVIDENCE, R. I.

### John Donaldson Jr., Works Firms on the Strength of his Father's Reputation.

It became known last week that John Donaldson, Jr., a young man having an office at 189 Broadway, New York, where he sold jewelry on commission, had skipped out leaving creditors whose claims against him amount to nearly \$2,500. Donaldson, who is the son of John Donaldson, an engraver at 20 Maiden Lane, worked with his father until about a year ago when he engaged as a broker, taking desk room in the office of Clarence F. Pearce, jeweler, 189 Broadway.

On the strength of his father's reputation he was able to obtain goods on credit from many diamond and jewelry firms. Recently his purchases and consignments of goods on memorandum materially increased and his creditors commenced to press him for an accounting. Wednesday last it was discovered that Donaldson had skipped and investigations followed. These led to a meeting of about 18 creditors Friday at the rooms of the New York Jewelers' Association, who out of consideration for Mr. Donaldson's father, decided to keep the matter quiet, and Lud-

wig Nissen, of Ludwig Nissen & Co., was chosen to act for the creditors in attempting to catch young Donaldson, force him to return the goods which he had in great part pawned, or make restitution.

Among the firms said to be losers by Donaldson's operations are Ludwig Nissen & Co., Randel, Baremore & Billings, Cross & Beguelin, Cooper & Forman, Morris Kollender, Alfred H. Smith & Co., Louis Strasburger's Son & Co., C. F. Pearce, J. W. Block & Bro., Simons, Bro. & Co., Smith & Knapp, and J. B. Bowden & Co.

Another meeting of the creditors was held Monday afternoon, Mr. Donaldson, the elder, being present. An arrangement was made by which the entire matter was put in the hands of Ludwig Nissen and John C. Mount, of Randel, Baremore & Billings, as a committee to act for all the creditors and secure an adjustment. It is understood that Donaldson's relatives will raise a fund and also assist in locating and restoring such goods as can be recovered. The creditors do not expect to lose any large amount of their claims.

### Chas. F. Wood & Co. Win Their Case Against an Indemnity Company.

From Tuesday, Jan. 22d, until Saturday evening, the trial of the suit of Chas. F. Wood & Co., 14 Maiden Lane, New York, against the American Credit Indemnity Co., occupied the attention of Judge Townsend and a jury in the United States Circuit Court, in New York. The action, which was for \$10,000, was brought on a policy for insurance against losses incurred in the year 1893.

The losses on which the plaintiffs endeavored to collect indemnity, were caused by the failures of E. F. Sanford & Co., E. E. Kipling and C. Cottier & Son. The principal defence was an allegation of fraud on the part of the plaintiffs, the defendants claiming that Chas. F. Wood & Co. knew these firms were about to fail when the accounts were insured. Other technical defenses were set up. After hearing exhaustive testimony on both sides the jury awarded a verdict in favor of Chas. F. Wood & Co. giving a judgment for \$6,200.

In awarding the amount, Judge Townsend directed that inasmuch as the plaintiffs had recovered a judgment for \$5,297 against the Mercantile Credit Guarantee Co. in a similar suit on these and other losses, the amount of the plaintiff's claim be modified accordingly and fixed at \$6,200. The case will probably be appealed to the United States Circuit Court of Appeals.

The sheriff, of New York county, Thursday, received an attachment for \$10,500 against the Kent & Stanley Co., in favor of Adolph Lewisohn, a dealer in metals, 81 Fulton St. Another attachment for \$1,782, in favor of W. G. McGrath, connected with the Lewisohn firm, was received Saturday. The Kent & Stanley Co.'s offices in New York are at 17 Maiden Lane, and in the Decker building, Union Square.

## FOX TAIL CHAINS.

Lowest Prices on the Market.

Superior to Imported.

Orders filled promptly in Gold, Silver, German Silver.

## Settings, Galleries, Ornamental Designs, Rich Borders in Rococo and Renaissance.

SEND FOR CATALOGUE

TO

## BLANCARD & CO.,

45 & 47 John Street, N. Y.

## TIME KEEPING ELECTRIC SIGN CLOCK.

To successfully advertise your place of business you must cater to the convenience as well as the aesthetic eye of the public. Examine the accompanying fac-simile of our Bracket Clocks.

Did you ever see any dummy so perfectly proportioned. We make this Clock for either Bracket or Post. It measures four feet from top of ring to bottom of ornament; is 30 inches in diameter and 10 inches thick. It is water and dust proof, and the dials are protected by Glass Bezels. Power is furnished by a small Battery. The circuit is opened and closed every 30 seconds by a small contact-wheel and spring placed on your regulator, thus moving the hands ahead every half minute.

The case is made of cast iron and the mechanism is simple. This clock is no experiment but a positive success and will last you a life time.



Price, from \$40.00 up.

CORRESPONDENCE SOLICITED.

JOLIET ELECTRIC MFG. CO.,

JOLIET, ILL.



## The Latest Patents.

ISSUE OF JAN. 22, 1895.

**532,821. GEM-SETTING.** EMIL SCHILL, Newark, N. J.—Filed Nov. 13, 1894. Serial No. 528,632. (No model.)



The method hereinbefore described of producing a setting for precious stones or pearls, consisting in first, forming a bezel *a*, then producing cup-shaped depressions *a'* therein, and soldering rings *d* on said bezel between said depressions, substantially as and for the purposes set forth.

**532,919. WATCH-DIAL FASTENER.** CHAS. D. SMITH, Bridgeport, Ohio.—Filed Mar. 31, 1894. Serial No. 505,939. (No model.)



In a fastening, the combination with a notched foot, of a notched and split locking pin set at right angles to the foot, substantially as and for the purposes specified.

## Providence.

Richard Robinson has entered the employ of F. T. Pearce & Co. as salesman.

E. Cohen, Toronto, Can., was registered at the Narragansett Hotel the past week.

George Hunt, of the old pioneer manufacturing concern of Hunt & Owen, is confined to his house by illness.

H. Benham, buyer for H. Benham & Co., Toronto, Can., was in the city the past week. He left for New York.

The administratrix of the estate of George W. Ladd has settled her final account to the Municipal Court which shows a balance on hand of \$5,626.21.

It is understood that several of the creditors of A. B. Kapp have accepted the offer of 25 cents on the dollar. A large majority, however, intend to hold for a hundred cents.

Clark H. Johnson, assignee for William L. Ballou Co., states that he will be unable to make any definite proposition looking toward a settlement for some time to come. For several weeks past the goods have been disposed of at auction sale with excellent results. It is estimated that the sales have amounted to \$125 per day on an average.

Elwood J. Fisher, the surviving partner of William M. Fisher & Co., gold, plated and silver chain manufacturers at 226 Eddy St., gave an assignment last Wednesday to Robert Thompson. So far as is known the financial standing of the concern is secure

and the assignment has been made solely for the sake of liquidation and to straighten out the several interests involved. William M. Fisher died several years ago and his estate is interested in the manufacturing property, and so is that of the late George R. Richardson, who, until his death, was a member of the firm. Mr. Thompson, the assignee, is at work on the company's books, but has yet nothing to say about the amounts involved.

## Canada and the Provinces.

George Chillas, of Montreal, is in Ottawa.

S. E. Stevenson, Elora, is offering his creditors 33 $\frac{1}{3}$  cents.

Rounsefeld & Co., jewelers, Winnipeg, Man., have gone out of business.

B. Kent, wholesale jeweler, of Toronto, was in Montreal on Tuesday last.

James Robertson, representing T. Lee & Co., Toronto, is in Montreal.

R. Russell, representing Levy Bros. Co., Hamilton, is doing Quebec Province.

J. A. Pitts, wholesale jobber, is in New York, buying goods for the Spring trade.

J. S. Leo, manager of the Montreal Optical Co., Montreal, left for Boston and New York last week.

J. E. Normandin, representing the Montreal Optical Co., is on a trip through the Ottawa valley.

Henry Birks and wife left for Colorado, a few days ago and will remain in that State for six weeks or two months.

Mr. Tripp, president of the Pairpoint Mfg. Co., New Bedford, Mass., was in Montreal for a couple of days last week.

George Smith, representing Simpson, Hall, Miller & Co., Montreal, is doing the Ottawa district and Charles Green, of the same firm, is in Toronto.

James O'Neil, for some time bookkeeper with A. A. Abbott, manager of the Canadian branch of Smith, Patterson & Co., Montreal, died last Sunday from consumption, and was buried on Tuesday.

Fred Croke, jeweler, New Westminster, B. C., has assigned. He started in business nearly 10 years ago with a few hundred dollars capital. Dull times is given as the cause of his failure.

## A Trustee for the Estate of Samuel Goodman.

NEW HAVEN, Conn., Jan. 29.—There was no contest in the Probate Court, yesterday morning, over the appointment of a trustee upon the estate of Samuel Goodman, the Chapel St. insolvent jeweler. Samuel H. Kirby was appointed by Judge Cleaveland. Commissioner will be appointed a week later. The schedule of assets and liabilities show that the liabilities are \$34,148.60 and the assets \$17,800.

## New York Notes.

(Continued from p. 32-b)

Bartens & Rice have filed a judgment for \$94.65 against Wm. B. Wilkins.

A judgment against Simon Dessau, for \$4,311.26, has been entered by S. A. Carson.

The graduating class of '04 of the Spencer Optical Institute, on Jan. 17 held a banquet at the Columbia, Union Square. Officers were elected and a handsome diamond ring and engrossed resolutions were presented to Dr. Heath, instructor.

John D. Maynard, for over 16 years a salesman for Tiffany & Co., in their fancy goods department, died early Saturday morning at the New York Hospital. Mr. Maynard had no relatives in this city. He was born in the vicinity of Boston, in 1851, and his family, who were in comfortable circumstances, gave him a liberal education. His father served in the Revolution, and after his mother died, young Maynard came on to New York, and of late lived at the Morton House. The funeral services were held at the residence of Joseph Harris, 303 E. 17th St., Jan. 29th, and were largely attended by his former associates.

One of the many incidents of the Brooklyn trolley ca strike was a considerate offer which was heartily appreciated by the members of Troop A. The quarters assigned to this company being very poor, Jeannot & Shiebler kindly offered them the use of the engravers' room of their watch case factory at Herkimer St. near Brooklyn Ave. As this is a large, well heated room, containing wash basins and other sanitary requisites, the offer was gladly accepted, and the recipients declare that the consideration shown by Jeannot & Shiebler will ever be remembered by the boys of Troop A.

The suit recently tried before Judge Beach, in the Supreme Court, which was brought by the Gorham Mfg. Co. against Chas. Seale to set aside Seale's assignment on the ground of fraudulent disposition of property, has been decided in favor of the defendant. In deciding, Judge Beach says: "The main point urged by plaintiff's counsel upon the trial was that the assignor's books left unaccounted for at date of assignment one hundred and twenty-two articles of stock. The defendant's counsel, by an exhaustive and specific analysis of the stock and other books in evidence, accounts for most of the merchandise testified by the assignor to have been 'presumably' in stock. This property, it seems, had been in part sold, and the rest could not be turned over to assignee, because out of assignor's possession in memorandum and pledged as collateral to loans. The business acts of the insolvent, for some time, just prior to the assignment, were reckless and improvident. But the evidence fails to convince me that such procedure was taken with an intent to hinder, delay or defraud his creditors." A decree is ordered for the defendants.

CLASSIFIED INDEX TO ADVERTISEMENTS.

All Advertisements are entitled to one insertion under proper heading. Extra insertions, \$6.00 per annum. Extra Headings, \$12.00 per annum.

<p><b>Art Pottery, Bric-a-brac, Etc.</b></p> <p>Bing, Ferdinand &amp; Co., 106 Grand St., N. Y. . . . . 74</p> <p>Borgfeldt, Geo. &amp; Co., 18, 20 &amp; 22 Washington Place, New York . . . . . 77</p> <p>Glaenzer, Léon J. &amp; Co., 80 &amp; 82 Chambers St., N. Y. . . . . 48a</p> <p>Hinrichs &amp; Co., 29 &amp; 31 Park Place, N. Y. . . . . 79</p> <p>Straus, L. &amp; Sons, 42 to 48 Warren St., N. Y. . . . . 73</p> <p>Vantine, A. A., &amp; Co., 877 &amp; 879 B'way, N. Y. . . . . 76</p> <p><b>Assayers &amp; Refiners.</b></p> <p>Goldsmith Bros., 63 &amp; 65 Washington St., Chicago, Ill. . . . . 26</p> <p>Rathbone, J., 1-9 Mathewson St., Providence, R. I. . . . . 65</p> <p>U. S. Smelting &amp; Refining Works, 25 John St., N. Y. . . . . 80</p> <p><b>Auctioneers.</b></p> <p>Comrie, A. J., 22 John St., N. Y. . . . . 65</p> <p>H. M. Rich &amp; Co., 21 School St., Boston, Mass. . . . . 5</p> <p><b>Badges, Medals, Etc.</b></p> <p>Stockwell, E. R., 19 John St. N. Y. . . . . 66</p> <p><b>Bicycles.</b></p> <p>Keating Wheel Co., Holyoke, Mass. . . . . 60</p> <p><b>Book Marks, Sterling Silver and Gold.</b></p> <p>Stone Bros., 535 Broadway, N. Y. . . . . 73</p> <p><b>Chains.</b></p> <p>W. &amp; S. Blackinton, Attleboro, Mass. . . . . 20</p> <p><b>Clocks, French, English and American.</b></p> <p>Ansonia Clock Co., 133-135 Wabash Ave., Chicago, Ill. . . . . Inside Back Cover</p> <p>Jacques, Chas. Clock Co., 22 Cortlandt St., N. Y. . . . . 80</p> <p>Joliet Electric Co., Joliet, Ill. . . . . 52</p> <p>Self-Winding Clock Co., 26 Broadway, N. Y. . . . . 80</p> <p>Seth Thomas Clock Co., 149-151 State St., Chicago, Ill. . . . . 34</p> <p><b>Cut Glass.</b></p> <p>Clark, T. B. &amp; Co., 860 Broadway, N. Y. . . . . 73</p> <p><b>Demagnetizers.</b></p> <p>Bowman, Ezra F. &amp; Co., Lancaster, Pa. . . . . 61</p> <p><b>Diamond &amp; Precious Stone Importers.</b></p> <p>Cottier, C., &amp; Son, 14 Maiden Lane, New York 80</p> <p>Disselkoen, John N., 5-7 Maiden Lane, N. Y. . . . . 67</p> <p>Falkenau, Oppenheimer &amp; Co., 40 Maiden Hedges, Wm. S. &amp; Co., 170 Broadway, N. Y. . . . . 66</p> <p>Kahn, L. &amp; M. &amp; Co., 172 Broadway, N. Y. . . . . 80</p> <p>Keller, Ettinger &amp; Fink, 24 John St. . . . . 11</p> <p>Kipling, R. A., Hays Bldg., N. Y. . . . . 66</p> <p>Knights, C. H., &amp; Co., Chicago, Ill. . . . . 2</p> <p>Smith, Alfred H. &amp; Co., 182 Broadway, N. Y. . . . . 66</p> <p>Tannenbaum, L., &amp; Co., cor. Maiden Lane and Nassau St., N. Y. . . . . 32c</p> <p>Young, Otto. &amp; Co., 149-153 State St., Chicago, Ill. . . . . Back Cover</p> <p><b>Diamond Cutters.</b></p> <p>Fox Bros. &amp; Co., 68 W. 4th St., Cincinnati, O. 71</p> <p>Oppenheimer Bros. &amp; Veith, 35 Maiden Lane, N. Y. . . . . 56</p> <p>Randel, Baremore &amp; Billings, 29 Maiden Lane 67</p> <p><b>Diamond Polishing Mills.</b></p> <p>Arthur Co., The, 86 John St., New York. . . . . 80</p>	<p><b>Ebony Goods.</b></p> <p>Deutsch Bros., 7 E. 17th St., N. Y. . . . . 48c</p> <p><b>Emblems.</b></p> <p>Irons &amp; Russell, Providence, R. I. . . . . 47</p> <p>Richardson, J. W. &amp; Co., 200 Broadway . . . . . 48d</p> <p><b>Enamelers.</b></p> <p>Wild, S. S. &amp; Son, 179 Eddy St., Providence, R. I. . . . . 79</p> <p><b>Fine Stationery.</b></p> <p>Parsons &amp; Greene Co., 18 Murray St., N. Y. . . . . 5</p> <p><b>Gold and Rolled Plate Jewelry.</b></p> <p>Foster &amp; Bailey, Providence, R. I. . . . . 3</p> <p>Waite, Thresher &amp; Co., Providence, R. I. . . . . 51</p> <p><b>Gold Jewelry.</b></p> <p>Aikin, Lambert &amp; Co., 19 Maiden Lane. . . . . 72-73</p> <p>Carter, Sloan &amp; Co., 15 Maiden Lane, N. Y. . . . . 67</p> <p>Greene, Geo. F., 111-113 Point St., Providence, R. I. . . . . 78</p> <p>Larter, Elcox &amp; Co., 21-23 Maiden Lane, N. Y. . . . . 14</p> <p>Reddall, John W., &amp; Co., Newark, N. J. . . . . 11</p> <p>Schwartz, W. H., &amp; Co., Newark, N. J. . . . . 60</p> <p><b>Horological Schools.</b></p> <p>Chicago Watchmaker's Institute. . . . . 71</p> <p>Parson's School for Watchmakers, Peoria, Ill. 71</p> <p>Philadelphia College of Horology, 623 Heed Building, Phila. Pa. . . . . 37</p> <p><b>Jewelry Boxes, Cases, Trays, &amp;c.</b></p> <p>Dennison Mfg. Co., 90-92 Wabash Ave., Chicago, Ill. . . . . 42</p> <p><b>Jobbers, Watches, Diamonds, Etc.</b></p> <p>Aikin-Lambert Jewelry Co., 19 Maiden Lane . 72 73</p> <p>Allen, Benj. &amp; Co., Chicago, Ill. . . . . 45</p> <p>Becken, A. C., 103 State St., Chicago, Ill. . . . . 24</p> <p>Lapp &amp; Fleshem, Chicago, Ill. Inside Front Cover</p> <p>Marquardt, G. W. &amp; Sons, Chicago, Ill. . . . . 8</p> <p>Myers, S. F. &amp; Co., 48 Maiden Lane, N. Y. . . . . 80</p> <p>Sproehle, F. M. &amp; Co., Chicago, Ill. . . . . 16</p> <p>Wallis, O. W. &amp; Co., 113 State St., Chicago, Ill. . . . . 69</p> <p>Young, Otto, &amp; Co., 149-153 Strte St., Chicago, Ill. . . . . Back Cover</p> <p><b>Monograms.</b></p> <p>Dietz, W. H., 115 Dearborn St., Chicago, Ill. . 71</p> <p><b>Musical Boxes.</b></p> <p>Jacot &amp; Son, 39 Union Square, N. Y. . . . . 73</p> <p><b>Musical Instruments.</b></p> <p>Lyon &amp; Healy, Wabash Ave. and Adams St., Chicago, Ill. . . . . 48</p> <p><b>Optical Goods.</b></p> <p>Geneva Optical Co., Chicago, Ills. . . . . 36-71</p> <p>Queen &amp; Co., Philadelphia, Pa. . . . . 80</p> <p><b>Optical Schools.</b></p> <p>Knowles, Dr., 4 Maiden Lane, N. Y. . . . . 55</p> <p><b>Pens, Pencils, etc.,</b></p> <p>Aikin, Lambert &amp; Co., 19 Maiden Lane, N. Y. 72-73</p> <p><b>Photo-Miniature.</b></p> <p>Favre Leon, 107 East 26th St., N. Y. . . . . 72</p> <p><b>Ring Makers.</b></p> <p>Bowden, J. B. &amp; Co., 192 Broadway, N. Y. . . . . 66</p> <p><b>Safes.</b></p> <p>Mosler, Bahmann &amp; Co., 518 B'way, N. Y. . . . . 73</p>	<p><b>Sample Trunks.</b></p> <p>Crouch &amp; Fitzgerald, 161 Broadway, N. Y. . . . . 5</p> <p><b>Settings, Galleries, &amp;c.</b></p> <p>Blancard &amp; Co., 45-47 John St., N. Y. . . . . 52</p> <p><b>Show Cases.</b></p> <p>Smith, B. &amp; W. B., 220 W. 29th St., N. Y. 58-59-80</p> <p><b>Show Trays.</b></p> <p>Fletcher Mfg. Co., 259 W. 27th St., N. Y. . . . . 64</p> <p><b>Silver Plated Ware.</b></p> <p>Adelphi Silver Plate Co., 62 John St., N. Y. . . . . 15</p> <p>Manhattan Silver Plate Co., 65 Washington St., Chicago, Ill. . . . . 32d</p> <p>Meriden Britannia Co., Chicago, Ill. . . . . 28</p> <p>Meriden Silver Plate Co., 133-135 Wabash Ave., Chicago, Ill. . . . . 46</p> <p>Middletown Plate Co., Middletown, Conn. . . . . 32</p> <p>Pairpoint Mfg. Co., New Bedford, Mass. . . . . 5</p> <p>Simpson, Hall, Miller &amp; Co., 141-143 State St., Chicago, Ill. . . . . 35</p> <p>The Wm. Rogers Mfg. Co., Hartford, Conn. . . . . 5</p> <p>Webster, G. A., Chicago, Ill. . . . . 71</p> <p><b>Sterling Silver Novelties.</b></p> <p>Codding Bros. &amp; Heilborn, North Attleboro Mass. . . . . 79</p> <p>Hagan, White &amp; Co., 243 W. 23d St., N. Y. . . . . 66</p> <p><b>Sterling Silverware.</b></p> <p>Bachrach &amp; Freedman, 1 &amp; 3 Union Sq., N. Y. 62</p> <p>Fuchs, Ferd. &amp; Bros., 808-810 Greenwich St., N. Y. . . . . 66</p> <p>Holmes &amp; Edwards Silver Co., 65 Washington St., Chicago, Ill. . . . . 33</p> <p>Knowles, J. B. &amp; S. M. Co., Silversmiths' Hall, Union Square, N. Y. . . . . 64</p> <p>Towle Mfg. Co., 149-151 State St., Chicago, Ill. . . . . 40-41</p> <p>Wallace, R. &amp; Sons Mfg. Co., Wallingford, Conn. . . . . 6</p> <p>Wood &amp; Hughes, 16 John St., N. Y. . . . . 8c</p> <p><b>Tool Manufacturers and Dealers.</b></p> <p>Allen, Benj. &amp; Co., Chicago, Ills. . . . . 45</p> <p>American Watch Tool Co., Waltham, Mass. . 73</p> <p>Glickauf &amp; Newhouse, 84 &amp; 86 State Street, Chicago, Ill. . . . . 10</p> <p>Moseley &amp; Co., Elgin, Ill. . . . . 71</p> <p>Mossberg Wrench Co., Attleboro, Mass. . . . . 79</p> <p>Oliver, W. W., Buffalo, N. Y. . . . . 80</p> <p><b>Trunks and Traveling Bags.</b></p> <p>Crouch &amp; Fitzgerald, 161 Broadway, N. Y. . . . . 5</p> <p><b>Watch Case Manufacturers.</b></p> <p>Bates &amp; Bacon, 167 Dearborn St., Chicago. . . 69</p> <p>Margot Bros., 11 Franklin St., Boston, Mass. . 57</p> <p>Dueber-Hampden Co., Canton, O. . . . . 57</p> <p><b>Watch Case Materials.</b></p> <p>Newark Watch Case Material Co., Newark, N. J. . . . . 63</p> <p><b>Watch Importers.</b></p> <p>Hyde's, J. E., Sons, 22 Maiden Lane, N. Y. . . 65</p> <p>Mathey Bros., Mathez &amp; Co., 21 &amp; 23 Maiden Lane, N. Y. . . . . 72</p> <p>Strasburger, B. L. &amp; Co., 17 Maiden Lane, N. Y. . . . . 62</p> <p><b>Watch Keys.</b></p> <p>Clark, A. N., Plainville, Conn. . . . . 80</p> <p><b>Watch Manufacturers.</b></p> <p>American Waltham Watch Co., Waltham, Mass 19</p> <p>Dueber-Hampden Co., Canton, O. . . . . 57</p> <p>Elgin National Watch Co., Chicago, Ill. . . . . 39</p>
-----------------------------------------------------------------------------------------------------------------------------------------------------------------------------------------------------------------------------------------------------------------------------------------------------------------------------------------------------------------------------------------------------------------------------------------------------------------------------------------------------------------------------------------------------------------------------------------------------------------------------------------------------------------------------------------------------------------------------------------------------------------------------------------------------------------------------------------------------------------------------------------------------------------------------------------------------------------------------------------------------------------------------------------------------------------------------------------------------------------------------------------------------------------------------------------------------------------------------------------------------------------------------------------------------------------------------------------------------------------------------------------------------------------------------------------------------------------------------------------------------------------------------------------------------------------------------------------------------------------------------------------------------------------------------------------------------------------------------------------------------------------------------------------------------------------------------------------------------------------------------------------------------------------------------------------------------------------------------------------------------------------------------------------------------------------------------------------------------------------------------------------------------------------------------------------------------------------------------------------------------------------------------------------------------------------------------------------------------------------------------------------------------------------------------------------------------------------------------------------------------------------------------------------------------------------------------------------------------------------------------------------------------------------------------------------------------------------------------------------------------------------------------------------------------------------------------------------------------------------------------------------------------------------------------------------------------------------------------------------------------	---------------------------------------------------------------------------------------------------------------------------------------------------------------------------------------------------------------------------------------------------------------------------------------------------------------------------------------------------------------------------------------------------------------------------------------------------------------------------------------------------------------------------------------------------------------------------------------------------------------------------------------------------------------------------------------------------------------------------------------------------------------------------------------------------------------------------------------------------------------------------------------------------------------------------------------------------------------------------------------------------------------------------------------------------------------------------------------------------------------------------------------------------------------------------------------------------------------------------------------------------------------------------------------------------------------------------------------------------------------------------------------------------------------------------------------------------------------------------------------------------------------------------------------------------------------------------------------------------------------------------------------------------------------------------------------------------------------------------------------------------------------------------------------------------------------------------------------------------------------------------------------------------------------------------------------------------------------------------------------------------------------------------------------------------------------------------------------------------------------------------------------------------------------------------------------------------------------------------------------------------------------------------------------------------------------------------------------------------------------------------------------------------------------------------------------------------------------------------------------------------------------------------------------------------------------------------------------------------------------------------------------------------------------------------------------------------------------------------------------------------------------------------------------------------------------------------------------------------------------------------------------------------------------------------------------	-------------------------------------------------------------------------------------------------------------------------------------------------------------------------------------------------------------------------------------------------------------------------------------------------------------------------------------------------------------------------------------------------------------------------------------------------------------------------------------------------------------------------------------------------------------------------------------------------------------------------------------------------------------------------------------------------------------------------------------------------------------------------------------------------------------------------------------------------------------------------------------------------------------------------------------------------------------------------------------------------------------------------------------------------------------------------------------------------------------------------------------------------------------------------------------------------------------------------------------------------------------------------------------------------------------------------------------------------------------------------------------------------------------------------------------------------------------------------------------------------------------------------------------------------------------------------------------------------------------------------------------------------------------------------------------------------------------------------------------------------------------------------------------------------------------------------------------------------------------------------------------------------------------------------------------------------------------------------------------------------------------------------------------------------------------------------------------------------------------------------------------------------------------------------------------------------------------------------------------------------------------------------------------------------------------------------------------------------------------------------------------------------------------------------------------------------------------------------------------------------------------------------------------------------------------------------------------------------------------------------------------------------------------------------------------------------------------------------------------------------------------------------------------------------------------------------------------------------------------------------------------------------------------------------------------------------------------------------------------------------------------------------------------------------------------------------------------------------------------------------------

## Special Notices.

Rates 75c. per insertion for notices not exceeding 3 lines (25 words); additional words 2 cents each. If answers are to be forwarded, postage stamps must be enclosed. Two insertions, 15 per cent. off; three insertions, 20 per cent. off; four insertions or more, 25 per cent. off. Payable strictly in advance. Display cards on this page will be charged at \$2.00 per inch for first insertion, subject to same discount as above for subsequent insertions.

Under the heading of **Situations Wanted** on this page advertisements will be inserted for One Cent a Word. This offer refers to **Situations Wanted only**. Payable strictly in advance. If answers are to be forwarded, postage must be enclosed.

## Situations Wanted.

*Notices under this heading ONLY are charged at one cent a word, payable strictly in advance. If answer are to be forwarded, postage must be enclosed.*

**BY** watchmaker. Experienced and have tools. Address Watchmaker, Box 52, Lanham, Neb.

**POSITION**—As watchmaker and salesman; will start at \$10 per week. Melvin Avery, Jackson, Mich.

**SITUATION** wanted by an experienced engraver, chaser, designer and letterer. Address Ed. S. Browe, Upper Montclair, N. J.

**WATCHMAKER**, first class, wants position; 25; A 1 references; full set of tools; good salesman, etc. Address J. G., care JEWELERS' CIRCULAR.

**A** MELTER, refiner, or one to work down silver or gold stock. Will go anywhere. Experienced, reliable. Address M. R., care of JEWELERS' CIRCULAR.

**A** FIRST-CLASS designer and modeler on silver-ware and jewelry is open for immediate engagement. Address Designer, Room 88, 33 Union Square, New York.

**A** FIRST-CLASS watchmaker would like position after January 1st. Full set of tools. References if required. Address Whitcomb, care of JEWELERS' CIRCULAR.

**ENGRAVER** and salesman desires position at once. Middle States preferred. Salary \$16. Reference given for character and ability. Address Commerce, care JEWELERS' CIRCULAR.

**WANTED**.—A 1 salesman wants city or near-by trade. Salary or commission. Seven years' experience. Reference unexceptional. Address X. X. B., care of JEWELERS' CIRCULAR.

**SITUATION WANTED** by April 1, 1895, as watchmaker. Do all ordinary watch work, clock work and gold soldering; four years' experience; A 1 references; good habits. Address R. I., Mt. Gilead, Ohio.

**FIRST CLASS** watchmaker, 28; experienced in materials, tools, also optical goods; speaks English, French and German; would like position as salesman in retail or wholesale material house. "Material," care JEWELERS' CIRCULAR.

**BOOKKEEPER**, absolutely reliable and competent to take charge of office, credits and collections, desires to make a change; for number of years in similar position in watch and diamond line; excellent references. Address Amiable, 170, Care JEWELERS' CIRCULAR.

**A** FIRST-CLASS watch repairer, jeweler and fair engraver, 20 years' experience; all tools; no bad habits; capable to take charge of bench work; good references; speaks German and English; would like a steady job. Address Conrad Kohler, 1766 N. Ashland Ave., Chicago, Ill.

**YOUNG MAN**, 19 YEARS, WOULD LIKE A POSITION WITH A JEWELRY CONCERN WHERE HE CAN ADVANCE HIMSELF. EXCELLENT REFERENCES. ADDRESS OFFICE, CARE JEWELERS' CIRCULAR.

## Help Wanted.

**WANTED**—EXPERIENCED TRAVELER in the optical line. on salary and commission. Address H., care of JEWELERS' CIRCULAR.

**WANTED**.—Watchmaker; young man; must have good references and furnish his own tools; by March 1st. Address Henry Harris, Hartford, Conn.

**WANTED**.—A first-class jewelry salesman, with an established trade, for the city and vicinity. Address City Salesman, care of JEWELERS' CIRCULAR.

**SALESMAN**—Energetic, traveling, who visits retail jewelry trade, to carry a side line; commission liberal; samples weigh two pounds. F. M. Sproehln & Co., 108 State St., Chicago.

**WANTED**.—Letter engravers on silver ware. Permanent positions in city, if satisfactory. Address, stating experience and salary expected, L. E., care of JEWELERS' CIRCULAR.

**WANTED**—Experienced traveling salesman to carry a leading and well-known line of spectacles and eyeglasses. Samples easily carried. Liberal commission. Address Optics, care JEWELERS' CIRCULAR.

## Business Opportunities.

**LAKEWOOD**, N. J., farm for sale or exchange for jewelry store. Pennsylvania or New York preferred. If you want a home residence or farm, look at this. Price, \$10,000. Address P. O. Box 29, Delhi, N. Y.

**A** GENTLEMAN, representing some of the best silverware houses in Europe, wishes to make arrangements with some gentleman of means to carry on a mutually beneficial business. Experienced preferred. Address J. V., Room 88, 33 Union Square, New York.

**A** BUSINESS man or engraver having about \$5,000 to invest may secure a partnership in a successful established engraving and light manufacturing business controlling a monopoly; thorough investigation allowed; highest references asked and given. "Manufacturer A. Z.," care JEWELERS' CIRCULAR.

**PARTNER WANTED**—For a favorably and well-known manufacturing jeweler, with a first-class trade and good line of staple gold goods; one to act as salesman and to furnish \$6,000 to \$8,000; said amount wanted to increase the business. For particulars address C. S. Carter, P. O. Box 1228, Providence, R. I.

**FOR SALE** cheap, for cash, or exchange for improved real estate, a fine jewelry store, established 20 years, in a southern New England city, convenient to seaside hotels, whose patrons bring a good summer trade. The owner has other business and resides out of town. The store is run by a manager. Address C. A. B., care JEWELERS' CIRCULAR, 189 Broadway New York.

## To Let.

**TO LET**—52 Maiden Lane, store and basement; also two upper floors. Apply Louis Herzog, on the premises.

**LOFTS TO LET** for light manufacturing purposes (jewelry). Apply to The Mauser Mfg. Co., 14 East 15th St., New York.

## Miscellaneous.

**WANTED**—A pair of flat second hand power rolls. Meyer Jewelry Co., 1018 Main St., Kansas City, Mo.

**WANTED**.—Good, strong safe, 80 inches high outside. Would like extra steel chest inside and fitted with drawers for jewelers' use. Address R. L. W., care of JEWELERS' CIRCULAR.

**WANTED**—A steel lined fire proof safe; give inside and outside measurement with maker's name and full description. Address K. M., JEWELERS' CIRCULAR.

**A** GOLD solder that has a 14 kt. color. will not tarnish with perspiration, and will flow on silver. Send 25 cents for sample of (the best of all gold solder), 50 cents per dwt. Address J. J. Kerr, Manufacturing Jeweler, Indiana, Pa.

**THE** Omaha Optical, Watchmaking and Engraving Institute, offers greater inducements than any other trade school in this country; our instructors are experienced in school work; we advance students rapidly in theory and practice; write for prospectus. 509 Sheely Block, Omaha, Neb.

**A** WELL KNOWN SALESMAN, having an office in New York and an established trade, would like to arrange with manufacturer to handle line of gold or silver goods for better class of trade. Would travel west if required. Address Experience, care of JEWELERS' CIRCULAR.

**WANTED** a line of jewelry, gold or silver novelties or staple goods to handle on commission or otherwise in connection with diamond stock in Chicago and surrounding country; am thoroughly acquainted with the trade and have my own office; references. Address Elmer A. Rich (formerly Chicago manager for Alfred H. Smith & Co.), 34 and 36 Washington St., Chicago, Ill.

## For Sale.

**FOR SALE**—Hydraulic press made by John Robertson & Son, Brooklyn, N. Y., in perfect order Address J. B. & S. M. Knowles Co., Providence, R. I.

**BURGLAR-PROOF SAFE** for sale. New. Having use of vault in store, will sacrifice large Moser burglar and fire proof safe; weight, five tons; lever-set; burglar-proof door on lower chest. Address Wm. A. Keddie, 14 Maiden Lane, New York.

## TAINTOR & McALPINE, OF EASTHAMPTON, MASS.,

Offer for sale their Jewelry and Stationery Store, or Jewelry Department sold separate if so desired. Stock all new and in good condition.

Jewelry stock with fixtures will inventory about \$5,000, and can be reduced if necessary. Reason for selling, have gone into the manufacturing business.

The above is an old established store with a good business and a large amount of bench work.

## WE OFFER A PRIZE OF \$50.00

For the best idea for a Souvenir of the Cotton States and International Exposition which opens in Atlanta, Ga., Sept. 20th. We wish a new and original souvenir in our line and one that can be made in series to cost about 50 cents each—Something to take the place of the bangle ring and souvenir idea—The decision to be made March 15th. Send in the design on a separate slip from your name.

MAIER & BERKELE, Atlanta, Ga.

## WHEEL CUTTING.

We make a specialty of Wheel Cutting, Demagnetizing and Watch Repairing for the trade. Complete plant. Send for price list.

## THE WINSLOW & PENNEY CO.

608 Masonic Temple, - CHICAGO.

## DR. KNOWLES'

## Private Course in Refraction.

LECTURE for the course, - \$20.00.

DIPLOMA engrossed on parchment, 5.00.

\$25.00

Special inducements offered to students who purchase an outfit.

## WRITE FOR PARTICULARS.

Office and Headquarters for Graduate Opticians,

4 MAIDEN LANE (up stairs), NEW YORK.

**SPECIAL**  
IN  
**THE JEWELERS'**  
**CIRCULAR**  
Produce the  
results desired.

**NOTICES**

## The National Association of Jobbers to be Dissolved.

The banquet hall of the Equitable building, New York, was again the scene of the convention of the National Association of Jobbers in American Watches, when the eleventh annual meeting was called to order, Tuesday morning, by president Her-



H. F. HAHN,  
PRESIDENT.

man F. Hahn. The roll call showed that the following firms were represented:

A. Paul & Co., D. C. Percival & Co., Smith, Patterson & Co., Boston, Mass.; H. A. Osgood & Son, Lewiston, Me.; Bogle Bros., White River Junction, Vt.; Henry Kohn & Sons, Hartford, Conn.; Aikin, Lambert Jewelry Co., C. K. Colby, Max Freund & Co., Henry Ginnell & Co., Keller, Ettinger & Fink, S. Levinson, Lissauer & Co., S. F. Myers & Co., Roseman & Levy, Rubenstein Bros., Adolphe Schwob, H. M. Smith & Co., Smith & Knapp, Hayden W. Wheeler & Co., and N. H. White & Co., New York; Philip Present, Rochester, N. Y.; L. Levy, I. J. Liberman, Syracuse, N. Y.; Henry Euler, H. O. Hurlburt & Sons, M. Sickles & Sons, Philadelphia, Pa.; Non-Retailing Co., Lancaster, Pa.; N. B. Levy & Bro., Scranton, Pa.; Goddard, Hill & Co., Heeren Bros. & Co., Pittsburgh, Pa.; Bowler & Burdick Co., Cleveland, O.; A. G. Schwab & Bro., Cincinnati, O.; H. F. Hahn & Co., Lapp & Flershem, O. W. Wallis & Co., Chicago; and Herman Oppenheimer & Co., Kansas City, Mo.

Among the firms represented by proxy were: G. B. Barrett & Co., M. Bonn & Co., Pittsburgh,

Pa.; Eugene Deimel, Detroit, Mich.; Albert Bros., Amberg & Goldberg, Bene, Lindenberg & Co., Duhme Co., Frohman, Wise & Newman, Henry Hahn & Co., Clemens Hellebush, Oskamp, Nolting & Co., D. Schroder & Co., and J. S. Voss & Sons, Cincinnati, O.; Robert Nelson & Co., Toledo, O.; Baldwin, Miller & Co., Heaton, Sims & Co., Indianapolis, Ind.; A. & L. Felsenthal, Glickauf & Newhouse, Hass & Co., C. F. Happel & Co., C. H. Knight & Co., Chas. Kolb & Co., F. Lewald & Co., S. J. Loeb, Louis Manheimer & Co., M. A. Mead & Co., Metzberg & Co., B. F. Norris, Alister & Co., F. M. Sproehne & Co., Stein & Ellbogen Co., and Otto Young & Co., Chicago; T. R. J. Ayres' Sons, Keokuk, Ia.; Ch. Preusser Jewelry Co., Milwaukee, Wis.; Minneapolis Jewelry Mfg. Co., Minneapolis, Minn.; Max Meyer & Bro. Co., Omaha, Neb.; S. A. Rider Jewelry Co., St. Louis, Mo.; and Woodstock, Hoefler & Co., Kansas City, Mo.

President Hahn then read his address.

Secretary Noyes' report showed the members in good standing to number 165, and his financial report showed a balance in the treasury of \$1 895.16.

The committee appointed to meet the National Retail Jewelers' Association at their last annual meeting reported that requests were sent by this body to the Jobbers' Association, that means be taken to stop retailing by jobbers, to stop the indiscriminate issuance of catalogues, and to stop the sale of goods by licensed jobbers to other members of the Association over whom the manufacturers have no control. The Retail Jewelers' Association also wanted arrangements effected so that they be represented at the meeting of the Jobbers' Association. A committee, consisting of Arthur S. Goodman, president of the National Retail Jewelers' Association, O. O. Stillman, Geo. H. Bowers and John Wilson, were in attendance close by, and asked a hearing at this meeting of the jobbers.

The entire matter was temporarily laid upon the table to be taken up later.

A committee of 15 was appointed to decide on what course of action the Association should pursue during the coming year. This committee consisted of David Keller, N. H. White, M. J. Lissauer, S. F. Myers, Benj. Allen, L. W. Flershem, Otto Heeren, Geo. M. Goddard, A. G. Schwab, Henry Euler, Willis B. Musser, D. C. Percival, H.

W. Patterson, R. E. Burdick and Herman Oppenheimer. At noon the meeting adjourned until 2.30 P. M.

The committee appointed at the morning session met early in the afternoon, David Keller, the chairman, presiding. After a general discussion it was unanimously decided that the affairs of the National Association of Jobbers in American Watches be wound up, its debts be paid and the assets be divided pro rata among the members in good standing.

This report was submitted at the afternoon session which commenced about 3 P. M. and was adopted. The executive committee are to wind up the affairs of the association. President Goodman, of the National Retail Jewelers' Association, delivered an address, and Mr. Stillman, another member of the committee from that organization, made a few remarks.

The closing exercises were marked by the presentation of a gavel to President Hahn. Mr. Keller, who acted as spokesman, presenting it on behalf of his colleagues, with a few timely and well chosen remarks.

The meeting then adjourned *sine die*.

## The Circular's Stamping Bill in the Nebraska Legislature.

LINCOLN, Neb., Jan. 24.—House roll No. 291, by Hairgrove, to prevent the disposing of goods or wares marked "sterling," "sterling silver" or "coin silver" without said goods or wares being sterling or coin silver, and providing a penalty therefor had its first hearing in the Legislature.

This is the measure drafted by THE JEWELERS' CIRCULAR.

Phillip Zellenka & Son will remove Feb. 10th from 37 Maiden Lane, New York, to the Seabury building, 59 Maiden Lane.

R. W. Wehrle, jeweler, Blairsville, Pa., had his show window artistically decorated with spruce and moss, on which were placed stuffed pheasants, quail and a fox.

Israel Weisbach, a diamond setter employed by L. & J. Adler & Co., 51 Maiden Lane, was a prisoner in the Tombs Police Court, Tuesday, charged with larceny by Nathan Kaplan, a dealer in jewelry at 80 Nassau St. Kaplan is said to have given Weisbach some diamonds to set in rings and the latter subsequently reported that he had lost the stones. Weisbach waived examination and was held in \$1,000 bail for trial.

Paul J. Slider, jeweler, Crystal Lake, Minn., offered a silver tea set to the one who would guess nearest the correct number of beans contained in a quart fruit jar. There were three who came anywhere near guessing the number. There were 3,982 beans in the jar. M. Lamberton guessed 3,971; Miss Fredericks, 3,921; J. M. Sterling, 3,990. Guessing at beans in quart jars is a good deal like looking for the hole after pulling your finger out of the water.

# OPPENHEIMER BROS. & VEITH,

35 MAIDEN LANE, - NEW YORK.

CUTTERS OF

DEALERS IN

# DIAMONDS, WATCHES.

HAMPDEN MOVEMENT, DUEBER CASES A SPECIALTY.

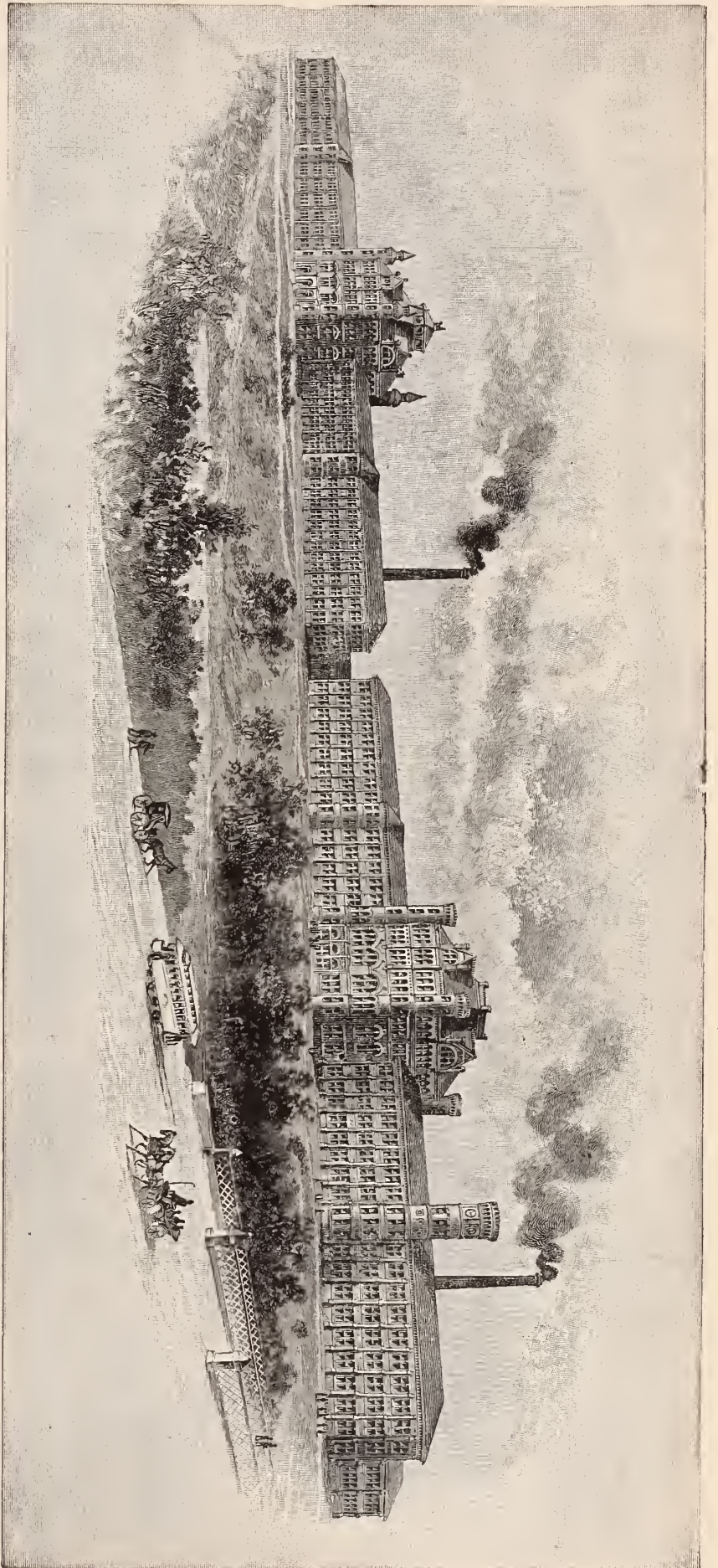

**THE DUEBER-HAMPDEN WATCH FACTORIES,  
CANTON, OHIO.**

**ARE THE LARGEST AND ONLY COMPLETE WATCH FACTORIES IN AMERICA.**

The policy of these companies has always been and will continue to be the best interests of the Retail Watch Maker and Jeweler. The rebate voucher system now in general use by us guarantees, as heretofore, a satisfactory margin of profit to all legitimate dealers selling . . . . .

**DUEBER-  
HAMPDEN  
WATCHES.**

**OUR MOTTO:** The welfare of the Jeweler depends more upon goods that are salable and yield him a good profit than upon any scheme, combination or organization. . . . .



Portion of Gorham Mfg. Co., Silversmiths, N. Y. City. Fitted entire by B. & W. P. Smith.

# B. & W. B. Smith,

220 WEST 29th STREET,  
New York City.

\*\*\*\*\*

A VISIT TO OUR SHOWROOM  
WILL REPAY YOU. YOU  
MAY LEARN SOME-  
THING ABOUT COUNTER AND  
WALL CASES. MANY NOVEL-  
TIES ON EXHIBITION.



Geo. W. Siebler & Co., Silversmiths, N. Y. City. Fitted entire by B. & W. P. Smith.



ESTIMATES GIVEN UPON  
APPLICATION. PAR-  
TIES WILL PLEASE  
SEND GROUND PLAN AND  
NUMBER OF FEET FRONT  
OF WALL CASES DESIRED.

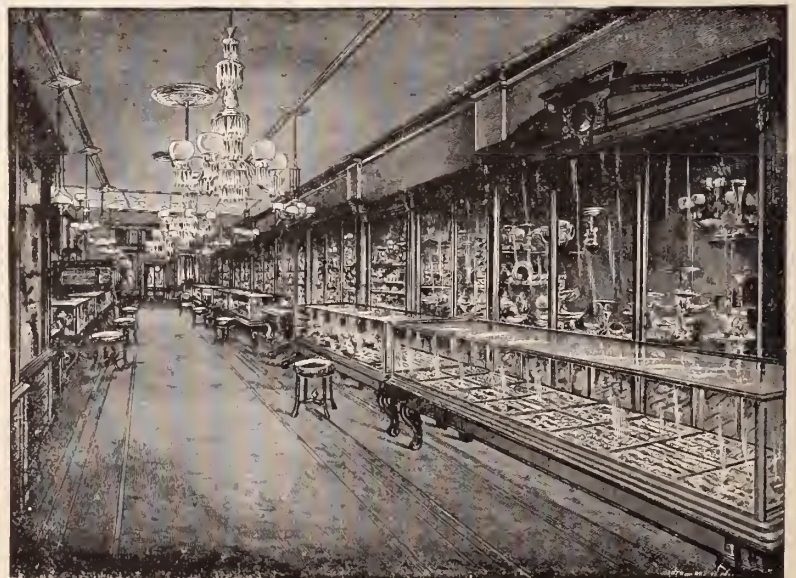

Reed & Barton, Silverware, 37 Union Sq., N. Y. City. Fitted entire by B. & W. B. Smith.



**B. & W. B. SMITH,**  
 220 WEST 29TH ST.,  
 N. Y. CITY.

Cases below have no frame or bar in front.  
 All Glass.

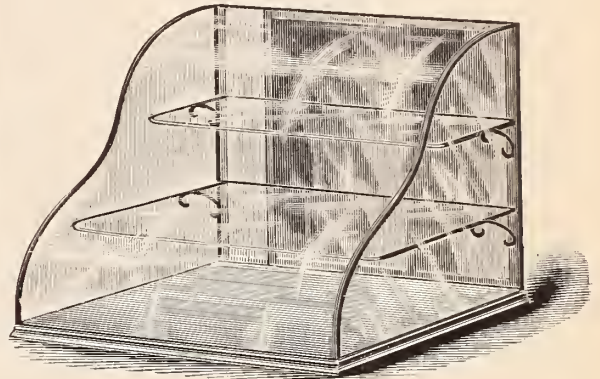

**O. G. FRONT.**

Size, 24 inches wide, 18 inches deep and 20 inches high. Glass Shelves.

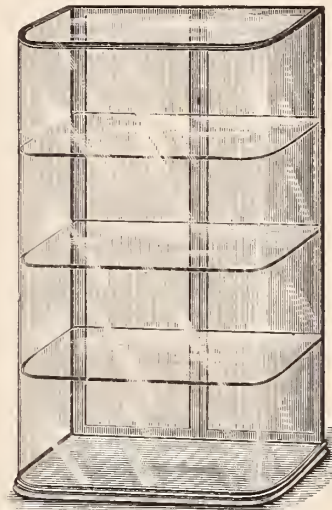

**CIRCULAR FRONT UPRIGHT, GLASS SHELVES.**

Size, 20 inches wide, 12 inches deep, 25 inches high.

CALL and SEE  
 OUR  
 SHOW ROOMS  
 VISITORS  
 RECEIVED  
 8 A. M. to  
 4.30 P. M.



**HAUSER, ZIVY & CO., JEWELRY STORE,  
 MEXICO CITY.  
 FITTED ENTIRE BY B. & W. B. SMITH.**

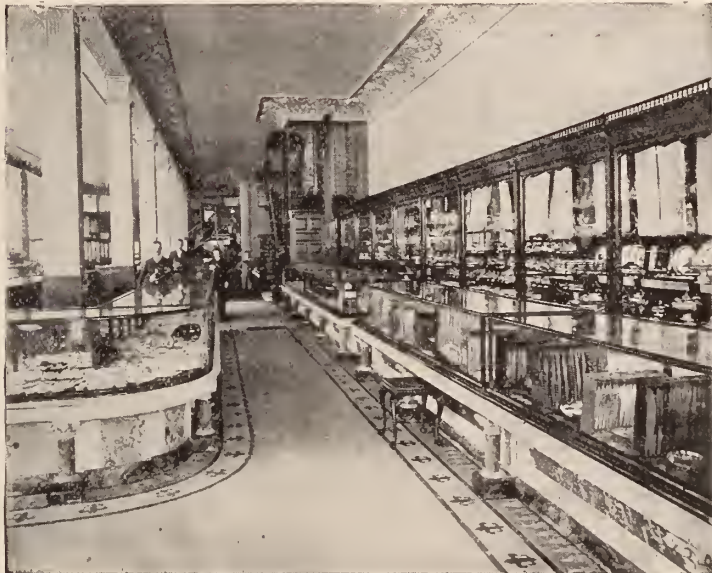

**SPAULDING & CO., JEWELRY STORE,  
 CHICAGO, ILLS.  
 FITTED ENTIRE BY B. & W. B. SMITH.**



**BUNDE & UPMEYER, JEWELERS,  
 MILWAUKEE, WIS.  
 FITTED ENTIRE BY B. & W. B. SMITH.**

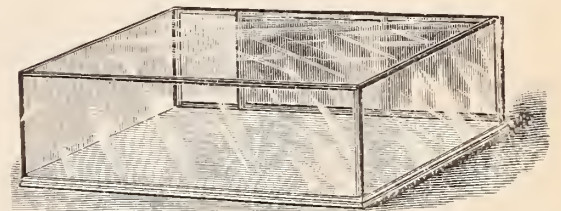

**HORIZONTAL, SLIDING GLASS DOORS IN BACK.**

Size of case 12 inches high, 24 inches wide. Any length.

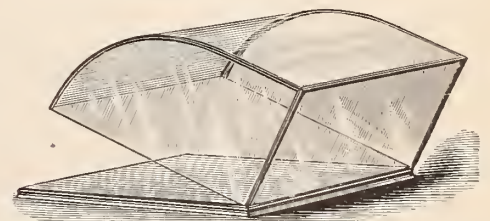

**SPECIALTY CASE.**

Size, 14 inches wide, 10 inches deep, 5 inches high. Hinged on back. Lock in front if required.

law allots three months before the writ is returnable, and the official has just so long a time in which to find his man. At the end of that time, supposing Mr. Kapp isn't to be found within the confines of Rhode Island, the creditors turn to his bondsmen for recourse. A new writ is then issued—a writ of scire-facias—and served upon the bondsmen, who will be the parties responsible for the defendant's non-appearance, and would have to make good the claims against him.

THE CIRCULAR is in receipt from Nicholas Muller's Sons & Co., manufacturers of art metal work, bronzes, lamps, etc., 224-232 W. 26th St., New York, of a bronze bust of the late Henry Woodfin Grady, the noted southern journalist. This work was done by Nicholas Muller's Sons & Co., upon the order of J. E. Muller, of Atlanta, Ga., after a model by Orion Frazee, another Georgian, both gentlemen being among Mr. Grady's warmest friends and admirers. The sculptor has endeavored to portray the beloved Georgian as he daily appeared among his friends, and his endeavors have been fully realized. The character of the subject has enabled Messrs. Muller & Co. to do their best to make a true copy of the original, and in this they have succeeded.

A circular has been addressed to the trade announcing the formation of a co-partnership by A. Joralemon, Chas. L. Joralemon and Harry K. Ingraham, under the firm name of Joralemon & Ingraham. The firm will carry on the business of manufacturing jewelers, at 49 and 51 Chestnut St., Newark, N. J.

### News Gleanings.

William A. Baker is a new jeweler in Fort Worth, Tex.

Henry Drukker, of Lawrence, Kan., will open a jewelry store in Atchison, Kan.

C. W. Harte, Waterloo, Wis., has sold out his jewelry stock to Albert J. Vick.

H. A. Potter, Pittsfield, Mass., has sold his jewelry business to a Mr. Stone, of Worcester.

In a destructive fire in Glasgow, Minn., W. W. Mabe's store was burned out; loss \$1,000; no insurance.

Max Rudert, formerly of Duquesne, Pa., has opened a jewelry store at 234 Fifth Ave., McKeesport, Pa.

J. Bennett has opened "The Great Metropolitan Loan Office and Jewelry Store," at 110 Church St., Norfolk, Va.

W. A. Schwalb has set up a jewelry shop in the front part of E. W. Helmick & Son's hardware store, Gibson City, Ill.

Fire broke out in the jewelry store owned by J. W. Eddy, Kewanee, Ill., Jan. 20. Little damage was done to the store.

The big steam engine which was bought to run the watch factory in Wichita, Kan., has been sold to an irrigation company.

Sheriff Coulter a few days ago disposed of the jewelry stock of C. A. Lindsey, Johnstown, Pa., for the benefit of creditors.

An attempt to rob E. F. Gilbert's jewelry store, Jacksonville, Fla., was made on the night of Jan. 20th, but the robber became

rattled by a curious pedestrian and ran off, leaving a ladder leaning against the transom over the rear door of the store.

Max Kaufman, a Berlin jeweler, is reported to have made a perfect ivory chariot with movable wheels, the whole weighing but two grains.

The Crook jewelry stock Hebron, Neb., was recently taken possession of by the sheriff for the benefit of creditors. Mr. Crook has gone south.

Charles Rudolph, son of C. F. Rudolph, Wilmington, Del., was married to Miss Allmond, daughter of ex-Mayor Allmond, of Wilmington, Jan. 22.

Burglars broke into the jewelry store of A. W. Stevenson, Middleburgh, N. Y., some nights ago, but were frightened away before they secured anything.

C. L. Rost, jeweler, Crawfordsville, Ind., has rented a room in the Crawford block and will move into it shortly. It be when refinished, the finest business room in the city.

The jewelry store of P. M. Tilghman, Crisfield, Md., was entered by burglars a few nights ago and jewelry and money to the amount of \$150 taken. There is no clue to the thieves.

The stock of Bean Brothers, dealers in jewelry and stationery, Ironwood, Mich., was levied on Jan. 21 by the sheriff. The firm expect to be able to adjust matters with their creditors.

The American Waltham Watch Co. will close their factory on the last four days of the current month for stock taking. President Fitch says that last year was one of the worst in the history of the watch trade all over the world, but that he is anticipating better conditions for 1895.

C. C. Sigler, jeweler and watch case manufacturer, Cleveland, O., was fined \$100 in police court Jan. 21 for violating the smoke ordinance. He made a motion for a new trial. This was overruled and the sentence imposed. Five days were given in which to file a bill of exceptions.

The Manhattan Silver Plate Co., Lyons, N. Y., have elected officers for the ensuing year. G. W. Hill, formerly secretary of the corporation, was elected adviser to the president and secretary. The board of directors met Monday evening, Jan. 21, and declared a dividend of 10 per cent. upon the capital stock of \$75,000.

The jewelry store of W. A. Allen & Co., DeLand, Fla., was recently burglarized. An entrance was made through a ventilator. Leading from the basement of the post office in the same building, there is an open stairway into a hall upon which a rear door of the jewelry store opens. The burglar sawed a hole in the rear door just above the lock, reached his hand through and turned the key. The haul was not a very rich one considering the stock that was at his mercy. Perhaps a dozen watches in the repairing department, belonging to customers, were taken.

**W. H. SCHWARTZ & CO.**  
 MANUFACTURERS OF FINE  
**JEWELRY**  
 AND  
 NOVELTIES  
 IN GOLD AND SILVER.  
 355 Mulberry Street.  
 Newark, N. J.

365 DAYS AHEAD OF THEM ALL.  
 Apply at Once for Catalogue and  
**BEATING BICYCLES**  
 AGENCY FOR  
 FACTORY, HOLYOKE, MASS.  
 SEE THAT CURVE

Jewelers make good agents, and get more profit on one bicycle than on six average watch sales.



Haberle Bros., Denver, Col., have assigned.

D. M. Hensley, Decatur, Ind., has given a mortgage for \$2,500.

Harry Gage has closed out his jewelry business in York, N. Y.

The store of L. A. Kimball, Stanbury, Mo., has been burned out.

J. A. Hertle, Buffalo, N. Y., has a judgment against him for \$278.

Mithvin Bros., Temple, Tex., have been succeeded by J. T. Anderson.

B. C. Mansfield, Grand Haven, Mich., has given a mortgage for \$700.

The Winnipeg Jewelry Co., Winnipeg, Man., suffered through a fire, Jan. 24.

G. H. May, Burlington, N. J., has opened a jewelry store in Washington, D. C.

Attorney J. J. Sullivan has qualified as assignee of Charles W. Collings, Niles, O.

Charles Morse, Colebrook, N. H., is settling with his creditors, at 25 cents on the dollar.

The late firm of C. N. Fleager, Georgetown, Tex., will now be known as C. N. Fleager & Co.

Claude Smith, who has been in the jewelry business in Buffalo, N. Y., has sold out there and will go east.

Gus Hooben, Taunton, Mass., refutes the report published last week that he intends to retire from business.

J. M. Phillips, jeweler, Portland, Ind., has moved into his new room, formerly occupied by Denney Bros.

W. A. Johnson, Danielsonville, Conn., who changed his location about a year ago, has re-occupied his old store.

A. Boyer and O. Walters have started a new silver and nickel plating establishment at 949 Hamilton St., Allentown, Pa.

Melvin Harley, of Benjamin Martin's jewelry store, Logansport, Ind., has gone to Chicago, where he will take a course in a school of engraving.

William Herzberg, Pottsville, Pa., is disposing of his varied stock of jewelry, etc., as he has to remove from his present location before April 1st.

Ellwood K. Bean, now with jeweler D. H. Krause, North Wales, Pa., has just bought out the jewelry store of H. B. Schanely, Lansdale, Pa.

The store occupied by E. F. Bennett, New Britain, Conn., who disposed of his stock at auction, will be opened about Feb. 1, by a former clerk in the establishment.

### Pittsburgh.

Jacob Grafner went west last week on a selling trip.

I. Ollendorf has disposed of real estate in Allegheny for \$8,000.

Maurice J. Baer is going east to tour the New England States on Feb. 1.

Samuel Weinhaus is contemplating a trip across the Atlantic about June 1st.

Grafner Bros. have taken their jewelry department out of Solomon & Ruben's department store.

Biggard & Wolfe, 113 Smithfield St., will take up quarters in the Monongahela House building on April 1.

R. Siedle & Sons are making alterations in their store by building a gallery in the rear of the room for more floor space.

J. C. Vincent, jewelers' auctioneer, has returned from Salem, O., where he has been selling out the stock of Max Bernstein.

Theo. Kaufman, buyer for Kaufman Bros., sails shortly on a month's European trip. He will import jewelry and art goods.

Max Loebnitz, representing the Dueber-Hampden Co., Canton, O., spent several days in the city last week, and spoke favorably of the change in Pittsburgh trade.

Among jewelers who visited the city last week were: Geo. V. Brady, Washington, Pa.; H. C. Morrison, Mt. Pleasant; C. Kennerdell, Freeport; and John Linnenbrink, Rochester, Pa.

Simon Stern, who victimized jewelers by the bogus check dodge, was recently located in Baltimore and brought to this city. Roberts, the other swindler, was captured, brought here, and railroaded through his trial, and a sentence of two years imposed upon him.

### Columbus.

G. Guggenheim, of Buffalo, N. Y., reached the city Saturday on his customary rounds. The sidewalks were very icy and Mr. Guggenheim fell, breaking his leg. He was at once taken care of by friends here and is at present at the Protestant Hospital.

The stockholders of the New Columbus Watch Co. at their annual meeting Thursday afternoon elected the following board of directors: J. B. Schueller, Fred Lazarus, Ralph Lazarus, C. T. Pfaff, William Reel, Charles A. Klie and W. W. Owen. The board of directors re-elected Charles A. Klie president and treasurer, J. B. Schueller, vice-president, and William Reel, secretary and general manager. The prospects for the new company are very encouraging.

F. F. Bonnet was the victim of a schemer who attempted to swindle him out of a fine gold watch last week. The man, after selecting a watch valued at between \$150 and \$200, left word that the works should be adjusted and that he would call again, which he did. The watch was for his father, who was at the Neil House, and he asked that one of the clerks might go with him to deliver the timepiece. When they arrived at the hotel the swindler said his father was in the bath room, and rather than delay the clerk he would show his father the watch, and if it suited him the clerk would be paid the price at once. He took the watch, and when the clerk got tired waiting and went to the adjoining room, he found it empty. The man has been arrested but the watch has not been turned in yet. The young man gave his name as Harry Hamilton, New York.

George M. Baker, the energetic and well known refiner of Providence, R. I., has all facilities for every detail of his business right on the premises. No smelting is put out to be done at second hand. Mr. Baker's improved smelting furnace, operated under his own eye, gives his customers assurance that work entrusted to him will receive the very best personal care and attention with the very natural sequence of the best returns.

# PERFECTION IN DEMAGNETIZERS.

"THE LITTLE GIANT." (PATENT ALLOWED).

ONE OF THE WONDERS OF THE AGE.

Sold on condition that if it fails to demagnetize the worst case of a magnetized watch by following the directions (which are so simple that a child can operate it), we will refund the money paid for it on return of the machine to us.

Style "A" for 110 volts, direct current,	-	-	\$25.00
" " "B" " 110 " alternating current,	-	-	20.00
" " "C" " 52 " " " " "	-	-	15.00

Less 6 per cent 10 days, 5 per cent. 30 days.

SOLD BY JOBBERS AT ABOVE PRICES.

EZRA F. BOWMAN & CO., Lancaster, Pa., SOLE MANUFACTURERS AND SELLING AGENTS.

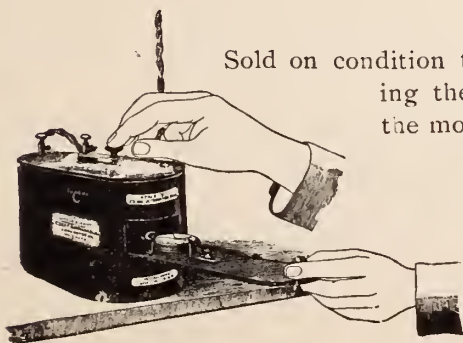

**Connecticut.**

E. F. Bennett, New Britain, closed a successful auction sale recently.

A jewelry and music store will be opened in Rogers' block on Main St., in New Britain, shortly.

Scoville Hitchcock, Southington, has settled with his creditors and resumed business.

S. H. Kirby, New Haven, has been elected a director of the New Haven Retail Merchants' Association.

E. S. Stevens, vice-president and manager of the Eagle Sterling Co., was in New York on a business trip last week.

An assignee's sale of watches, jewelry, diamonds, silverware, etc., is in progress at 218 Asylum St., Hartford.

Jeweler Frederick L. Hartenstein, Rockville, expects to leave for Salt Lake City this week, in search of health.

The board of directors of the Southington Cutlery Co., Southington, met Jan. 22d, and declared a dividend of two per cent.

The Derby Silver Co.'s works, Birmingham,

started Jan. 21st, to run full handed for six days per week, nine hours per day.

Joseph P. Smith, for many years identified with the Williams Bros. Mfg. Co., Naubuc, has engaged as a foreman with C. Rogers & Bros., Meriden.

George W. Taylor, who has been employed at the Maltby, Stevens & Curtiss Co., Wallingford, as die sinker, has gone to Providence, R. I., where he has accepted a similar position with the J. B. & S. M. Knowles Co.

The Upson Jewelry Co., Waterbury, have secured a home in an excellent location, that now occupied by the Apothecaries Hall Co., one of the most central stores in the city. They will take possession of their new headquarters about April 1.

The Waterbury Watch Co. at their annual meeting Wednesday afternoon, Jan. 23d, re-elected the following directors: A. S. Chase, Israel Holmes, H. W. Scovill, P. B. Burnham, A. O. Jennings, E. L. Frisbie, Jr., W. H. Hungerford. The directors chose these officers: President, A. S. Chase; treasurer, E. L. Frisbie, Jr.; secretary, A. O. Jennings.

The Silver City Plate Co., Meriden, are the newest industry bidding for trade in the Britannia line. They are not touching the flatware business, but will compete for a share of the hollowware trade. The company started on S. Colony St. last Fall and have recently taken quarters on Veteran St. Henry Felix, who formerly worked in the stock room of the Britannia Co.'s shop, and who left ten years ago for Canada, to take charge of the burnishing department of the Toronto Silver Plate Co., is associated with three other gentlemen in the venture.

At the annual meeting of the Rogers Cutlery Co., Hartford, Jan. 23d, the following board of directors were elected: Wm. H. Watrous, Scott Watrous, George H. Wilcox, D. B. Hamilton. The officers elected were: William H. Watrous, president and treasurer; George W. Watrous, secretary. A cash dividend of 25 per cent. was paid out of the earnings of the past year. At the annual meeting of the William Rogers Mfg. Co. the following were elected: Directors, William H. Watrous, George H. Wilcox, George W. Watrous, D. B. Hamilton; officers, president and treasurer, William H. Watrous, secretary, George W. Watrous. A cash dividend of 25 per cent. was paid out of the earnings of the year.

At 5 o'clock the morning of the 22d inst., the McAvoy residence, 2321 Calumet Ave., Chicago, the home of Moses Goldsmith, was totally destroyed by fire. Smoke pouring into the rooms awakened the family and they sought safety in immediate flight leaving behind all their personal property, which was a total loss. Mr. Goldsmith, who is the senior member of Goldsmith Bros., refiners, seemed a happy man though, when seen by THE CIRCULAR representative the next day. The reason was that on the evening of the 22d Mrs. Goldsmith presented him with a lusty 10 lb. baby boy, and mother and child were getting on nicely. A coincidence to this was the birth to Mr. and Mrs. Simon Goldsmith on the 20th inst., of their first born—a healthy boy, the two births dating within 48 hours of each other. Simon Goldsmith is the junior member of the firm. It was an interesting week in the Goldsmith households.

The "Restless and Sleepless" standard price-list for the year 1895, just issued by B. F. Norris, Alister & Co., is a work of some 720 pages, brimfull of good things the jeweler should know, and contains a number of things new to books of the kind. Specially attractive are the numerous colored plates, showing original packages and their labels in colors true to the original, which gives a value to the work not to be given in "black and white." The work is nicely bound in cream cloth, with black inscription on front cover, and a postal card addressed to the firm will bring it to you if you are a legitimate jeweler.

**BYRON L. STRASBURGER & Co.,**

IMPORTERS OF WATCHES  
AND MAKERS OF  
FINE DIAMOND JEWELRY,

**HAVE REMOVED TO**

**17 MAIDEN LANE, NEW YORK.**

**1895 NOVELTIES.**

**"SMART"**

**"ORIGINAL."**

**BACHRACH & FREEDMAN,**

**SILVERSMITHS,**

**Masonic Temple, CHICAGO.**



**1-3 UNION SQUARE,  
NEW YORK.**

**230 KEARNEY STREET,  
SAN FRANCISCO.**

Letters to The Editor.

THE MEETING OF THE MASSACHUSETT'S RETAILERS FROM ANOTHER POINT OF VIEW.

MEDFORD, Mass., Jan. 26, 1895.

Editor of THE JEWELERS' CIRCULAR:

DEAR SIR: The report you give of the Massachusetts jewelers' meeting held in Boston, Jan. 17, savors more of the interest of the National Association than I think it should, and I would like the privilege of a few words through the columns of your paper.

There are a few things the Massachusetts jewelers should think of and consider well before any affiliation is made with the so-called "National Association." By intrigue a temporary chairman was elected, in the absence of Mr. Wood, who is an ex-newspaper man employed by a Boston firm as advertising manager, etc., and by no means a "jeweler," whose arbitrary rulings and insults given the organizer, Mr. Dexter, made anything but an agreeable impression; also when he called for some one to take the chair temporarily, and the temerity of an officer of the National Association in assuming the chair, showing conclusively that honorable methods were not present in the opposition—the National Association.

The presence of Mr. Goodman uninvited and unannounced must cause the thinking men of the craft to consider the conception of meaner tactics by the National difficult to imagine. After some discussion Mr. Goodman was allowed to state the benefits the Massachusetts jeweler could derive from its connection with him and his association, but after he had talked some few minutes and not touched the subject on which he was to speak and when reminded of his subject

was indignant; his publication gives as much information on this subject as he gave before the meeting—nothing.

Mr. Dexter seems to be condemned by the National Association because he honorably says he derives his expense money from John C. Dueber, while Mr. Goodman says he enjoys the honor of traveling by "private subscription."

I hope that the Massachusetts craft may enjoy the honor of an Association of its own; surely one could do no less for the trade than the work shown by the National Association. Very truly yours,

EDW. W. MITCHELL.

Philadelphia.

George Kite, of the Quaker City Watch Co., has returned to business after a severe illness.

Simon Muhr, who has been quite ill at his home, 1936 Arch St., from nervous prostration, is improving.

Chas. H. O'Bryon, Chas. P. Sutton and James D. Hughes were guests at the recent Manufacturers' Club reception.

The principal creditors of Gustav Yeager, whose failure was announced in last week's CIRCULAR, are M. Sickles & Sons, to the extent of about \$1,000.

John C. Dueber, of the Dueber-Hampden Co., Canton, O., and his business manager, W. A. Moore, paid a visit to the Philadelphia agency recently.

Among the salesmen in Philadelphia the past week were: Leo Henle, Sussfeld, Lorsch & Co.; Mr. Crane, Mandeville, Carrow & Crane, and A. M. Leibmans, E. P. Reichhelm & Co.

On trial last week in Common Pleas was the case of E. Aug. Neresheimer & Co.,

New York, against the Keystone Watch Case Co., on a feigned issue to determine the ownership of diamonds and jewelry valued at \$8,000.

The colored thief who stole a watch from Mr. Jackemite's store, 1221 N. 10th St., has been captured and committed for trial. His name is John Parker, and he was arrested on a description furnished to the police. He was also identified by Mrs. and Miss Jackemite.

On Saturday the Hendry Cutlery Co., Limited, made an assignment for the benefit of creditors to Charles Cobb Van Riper. The instrument is dated Jan. 24, and is signed by John G. Wightman, chairman, and W. S. Emerson, secretary. No real estate is conveyed.

Alfred G. Schmidt, surviving partner of the firm of P. S. Schmidt & Sons, 625 Poplar St., made an assignment last week for the benefit of creditors, to Harry S. Greenwald. The deed conveys a two-story brick house on Poplar St. west of Marshall, but the amount involved is not large.

The appraisers appointed by Common Pleas Court, No. 1 to make an inventory of the estate of John G. Rosengarten, Elmer F. Pfersick and Wm. M. Ettinger, trading as J. G. Rosengarten & Co. and George J. Dekner & Co., have filed their report, in which they value the assets at \$1,940.20.

Out-of-town buyers here during the past week included: Mr. Funk, of Stoll & Funk, Lebanon, Pa.; E. P. Zane, Christiania, Pa.; L. H. Bewley, Atlantic City, N. J.; J. E. Reidenbach, Riverton, N. J.; Garnet Mertz, Mahonoy City, Pa.; Robert Steel, Hammononton, N. J.; J. Schlieter, Limerick, Pa.; Harold A. Fitch, of Lemend & Fitch, Salisbury, Md., and George P. Press, Oxford, Pa.

HEADQUARTERS FOR WATCH CASE MATERIALS.

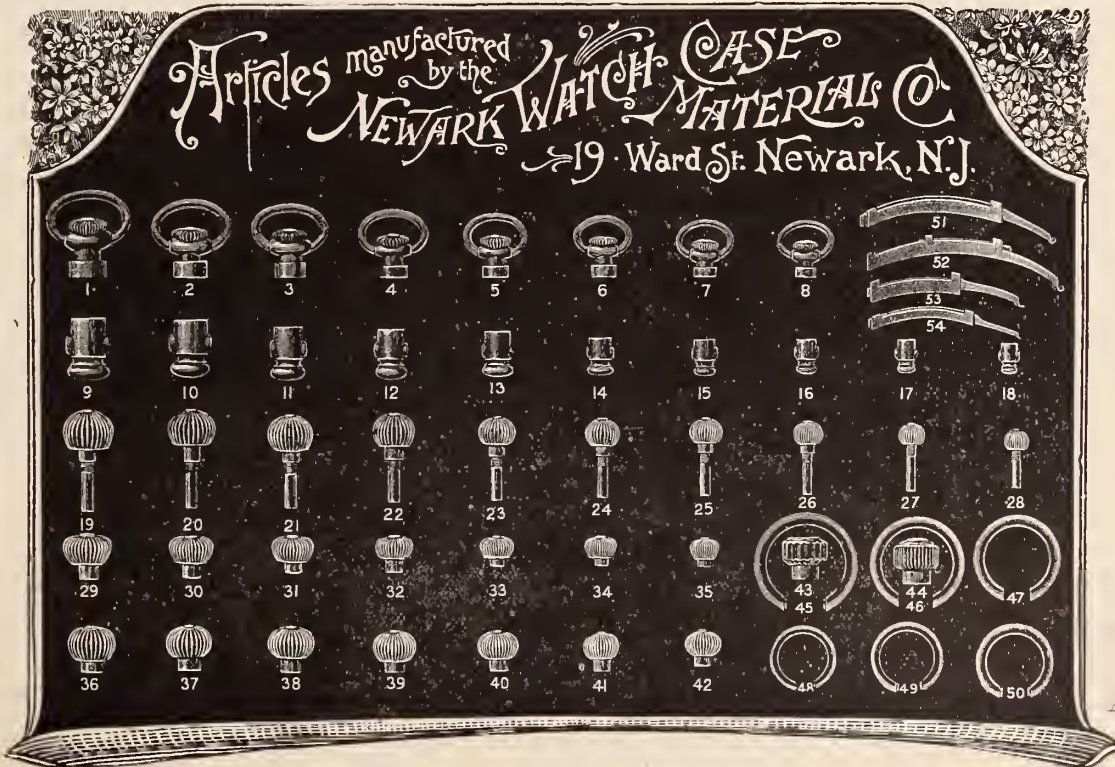

QUALITY GUARANTEED. WRITE FOR PRICES.

**Some Fine Work of B. & W. B. Smith.**

**T**HERE is no firm of show case manufacturers in the world who have produced finer work than B. & W. B. Smith, 220 W. 29th St., New York. Their advertisement in this week's issue of THE CIRCULAR shows some fine store fittings, as well as some specimens of fine cases fitted at the corners without wood or metal, this class of work being a special feature with B. & W. B. Smith.

This firm are just finishing a large contract for the Metropolitan Museum of Art, New York, which includes cases for the Jessup Wood Collection in the new wing; two cases are the largest bent wall cases ever made, being 30 feet in a half circle. The glass of the case which contains the Courier group measures 144x100 inches. The view in the firm's advertisement gives but a faint idea of the work as it appears in the Museum, as the case is the largest in

the world, being 32 feet long, 16 feet wide and 16 feet high. It has four lights of glass and the roof weighs 3,000 pounds. This case contains a group of moose and buffalo, life size.

At the showrooms of B. & W. B. Smith there are on exhibition specimens of their work, to inspect which parties interested are always welcome.

**The "Little Giant" Demagnetizer.**

**T**HE prevalence of magnetism in watches is almost as fatal to the good performance of the watch as consumption is to the human system. The many inquiries Ezra F. Bowman & Co., Lancaster, Pa., have received in the last year for a good demagnetizer, and the large number of watches which have been sent them for demagnetization have led the firm to look thoroughly into the subject of eradicating the magnetism from the watch in the most

efficacious manner. The illustration here-  
 shows the Little Giant Demagnetizer, on which a patent was allowed Sept. 13th, 1894. The operation of demagnetizing watches with this machine is so simple that a child can operate it. The result is so per-

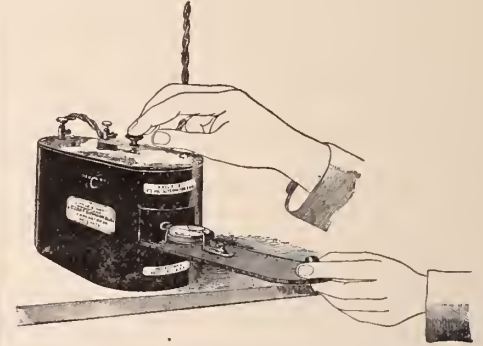

fect that it has baffled expert electricians. To meet the demands of the different currents furnished by the electric power companies these are made in three sizes. Style A is for the direct current of 100 to 120 volts; style B is made for the alternating current of 110 volts, and style C for a resistance of 52 volts alternating current. Ezra F. Bowman & Co., Lancaster, Pa., are the sole agents for these machines and they will cheerfully give prices and any further information in reference to the same.

**Indianapolis.**

Louis Kiefer has just returned from a visit to his orange and pine-apple groves in Florida.

Horace A. Comstock has taken his dog and gun and left for a hunt in the Tennessee mountains.

Jan. 10th, 1895, J. E. Reagan was admitted as a member of the firm of Baldwin, Miller & Co. The firm name remains the same.

Travelers for the wholesale dealers are busy preparing their new lines for the Spring trade. February 1st will see them all on the road.

The Indianapolis jobbers have received invitations to the Eleventh Annual Meeting of the National Association of Jobbers in American Watches, to be held Jan. 29th in New York.

Some State jewelers in town last week were: E. M. Wilhite, Danville; J. W. Hudson, Fortville; Woodruff, Edinburg; L. J. Small, Carmel; T. F. Cahill, Spencer; A. Hawkins, Noblesville; W. A. Pilkenton, McCordsville; C. Alford, Arlington; Geo. A. Fletcher, Carthage.

Last week Indianapolis was visited by the following jewelry representatives: John S. Jepson, Byron L. Strasburger & Co.; John J. Robinson, Holden & Knox Mfg. Co.; Mr. Sherrill, Sincock & Sherrill; F. B. Lawton, S. B. Champlin & Son; E. M. Blake, Bardon, Blake & Co.; Wilber Pond, E. G. Webster & Son; John Lamb, T. I. Smith & Co.; Abel King, I. Emrich & Co.; E. A. Tyler, Ansonia Clock Co.; David Swartz, Nicholas Muller's Son & Co.

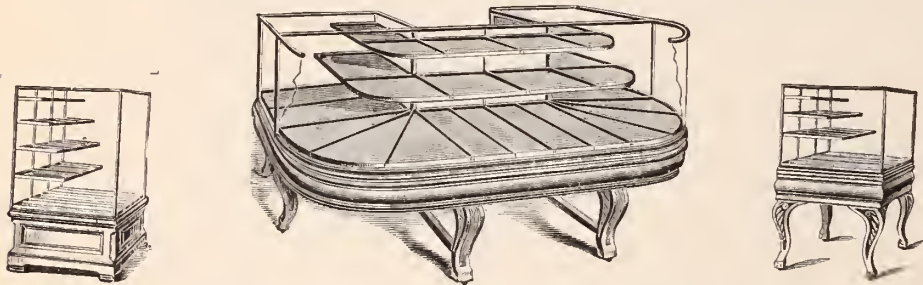

**NOW** is the time to act in fitting up your store for the Spring trade. The advantages of the **FLETCHER PATENT SYSTEM** of trays, in saving of room, speed and attractiveness, also the various appliances in store fittings made by the **FLETCHER MFG. CO.** to facilitate business should be born in mind **NOW**

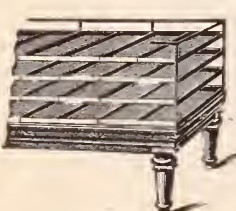

**THE FLETCHER MFG. CO.,**  
 259 WEST 27th STREET,  
 NEW YORK CITY.

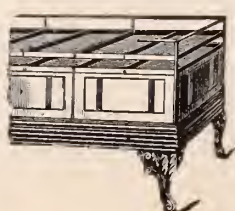

NEW CREATIONS THIS SEASON.  
 SEND FOR CATALOGUE.

**The J. B. & S. M. Knowles Co.'s New Building.**

PROVIDENCE, R. I., Jan. 25.—J. B. & S. M. Knowles Co., located for over a quarter of a century at 95 Pine St., are now comfortably established in the handsome modern structure on Sabin St., known as the

passes into the general offices, handsomely paneled in quartered oak and selected ash on both walls and ceilings. Private offices cosily and artistically fitted up occupy the righthand side, while at the back are the counters and a handsome display case. A packing room and toilet rooms with all



THE NEW FACTORY OF THE J. B. & S. M. KNOWLES CO.

Talcott building. In this building the company have greatly superior facilities for the production of their excellent and popular goods which have placed the name of this house among those of the foremost silversmiths in this country.

A glance through the firm's new offices and shops will be of interest. These occupy the two lower floors of the building. On entering from the street the visitor

other necessary modern office conveniences are all to be found, judiciously disposed.

In the rear of this floor is placed the heavier machinery, specially noticeable among which are modern drops solidly bedded in a granite and concrete foundation and which will produce die work equal if not superior to the finest. There are all conveniences for the workmen in the shape of cloak rooms, lockers, toilet rooms, etc.

A staircase in the center of the floor furnishes easy access to the floor above. Here are located the stock room, designer's room, foreman's quarters, die cutters' room, etc., all well placed along the Sabin St. front. The rest of the floor is devoted to the finishing and polishing department and other factory accessories. The same conveniences for the workmen found on the lower floor are also on this floor. All the fitting has been done by men of skill and experience in their lines and no details enhancing facility of production and the comfort of the workmen have been neglected. The firm's idea in moving, which was imperatively necessary owing to lack of room, etc., was that if they must move, their new quarters would at least be as perfect as their experience since 1852 would enable them to have. That they have succeeded it needs but a visit at the new Sabin St. shop to see.

All details, such as stock safes, safes for finished goods, furnaces, modern machinery and the thousand and one things that go to make a perfect shop are here, and dealers who have found the J. B. & S. M. Knowles Co.'s wares to be popular, artistic and salable, will hereafter find them even better if that be possible.

**A Complete Establishment**

MEANS

**PERFECT WORK**

In every detail of

**ASSAYING,  
REFINING  
AND  
SMELTING.**

The proof that mine is such lies in the prompt and satisfactory returns invariably given all my customers. ARE YOU ONE?

HIGHEST MARKET RATES FOR OLD GOLD AND SILVER.

**J. RATHBONE,**

Nos. 1 to 9 Matthewson St., cor. Cove, Providence, R. I.

**A. J. COMRIE,**

AUCTIONEER,

22 John St., N. Y.

SPECIAL SALESMAN OF WATCHES, DIAMONDS' BRIC-A-BRAC, FOR ESTABLISHED JEWELERS.

WRITE FOR PARTICULARS.

DON'T FORGET THE JEWELERS' CIRCULAR PUBLISHING CO.'S BOOK LIST when in want any technical book in the Jewelry or Kindred Trades.

**Jules Jürgensen**

OF COPENHAGEN.

The reputation these watches have maintained for Fifty Years has never been equalled, being made on strictly scientific principles and no expense spared to give the Best results in mechanism and timekeeping qualities.

SOLE AGENTS.

**John C. Hyde's Sons,**  
NO. 22 MAIDEN LANE.

**DIAMONDS.****Wm. S. Hedges & Co.,****Importers of Diamonds,**

And Manufacturers of DIAMOND JEWELRY.

**170 Broadway, New York.**

22 Holborn Viaduct, London.

**Alfred H. Smith & Co.,**IMPORTERSDIAMONDS

AND

PRECIOUS STONES,**182 BROADWAY, COR. JOHN STREET,**

NEW YORK.

**83 Holborn Viaduct. London. E. C.****R. A. KIPLING,****Precious Stones**AND **Fancy Goods****Bought and Sold on Commission.****19 RUE DROUOT,****PARIS, FRANCE.****FERD. FUCHS & BROS.****SILVERSMITHS,**

MAKERS OF STERLING SILVERWARE,

**808-810 Greenwich St.. New York.**For **BADGES and MEDALS,**

Flag Pins, Class Pins, Class Rings

and Special Work of all Descriptions,

SEND TO **E. R. STOCKWELL, MANUF'R.,****19 John Street,****New York.****THE BOWDEN****SEAMLESS RING**

IS MADE ONLY BY

**J. B. BOWDEN & Co.,****Makers of Finger Rings of every Description.**

REMOVED FROM BROADWAY AND JOHN STREET,

**TO 3 MAIDEN LANE,**

NEW YORK.

**HAGAN, WHITE & CO.,**

MANUFACTURERS OF

**GOLD AND SILVER MOUNTED CANES, UMBRELLAS & NOVELTIES.**

RICH AMERICAN CUT GLASS, SILVER MOUNTED.

**248 WEST 23D STREET,****NEW YORK.****As to "The Father of the American Watchmaking Industry."**

In the following letter addressed to the editor of the Boston *Globe*, Edward Howard says that the late A. L. Dennison never claimed the sole title to "Father of the American Watchmaking Industry":

*To the Editor of The Globe:*

In several of the papers in this city and vicinity, about Jan. 11 I saw notices of the death of Aaron L. Dennison, "The Father of American Watchmaking," so-called, with a short history of his life, and, as there was some inaccuracy in the statements, particularly in the claim of being the "father of American watchmaking," I take the liberty of making some corrections.

I never tried, as stated, to get Mr. Dennison interested in the manufacture of locomotives, but the firm of Howard & Davis were then considering that matter, and my mentioning it to Mr. Dennison caused him to speak to me on the subject of watchmaking, and I being a clockmaker, the subject was readily taken up and talked over frequently for several months.

Finally, in 1850, Mr. Samuel Curtis, of Boston, was induced to invest \$20,000 in the project, that being thought sufficient to establish the business. A two-story brick building, 100 feet long and 25 feet wide, was then erected in Roxbury, Mass., and work at once commenced under the name of the American Horological Company, comprising Howard & Davis, Samuel Curtis and A. L. Dennison.

It was not many months before the \$20,000 put in by Mr. Curtis was all expended, and \$20,000 was then put in by Howard & Davis. In the meantime the name of the company had been changed to the Warren Mfg. Co., and soon after to the Boston Watch Co., which name was retained until the company's property in Waltham was sold in 1857.

After working in Roxbury for more than three years, the company built a factory in Waltham, and moved there in 1854. There was only one financial failure, and that was in 1857, but it was a wonder to me that it did not fail long before that time, under the wildest kind of mismanagement, for, instead of using \$20,000 as contemplated, \$250,000 had been expended, which made me the busiest man in town, looking after money to fill the gap.

Now, in regard to Mr. A. L. Dennison being the "father of American watchmaking," I do not think he ever made such a claim. He believed watches could be made on the interchangeable plan, but the tools and machines required to bring about that interchangeability, with the necessary accuracy and facility, were not his designs or inventions; that was well known by all the principal workmen in the factory, many of whom are now living, who will confirm that statement.

It is one thing to believe a thing can be done and another to invent suitable machines and tools to do it. I believe people will fly at some time, but that does not make me the father of flying or the machine that is to do the flying.

In regard to the claim of being the "father of American watchmaking," the whole of that claim was persistently made by his brother, Mr. E. W. Dennison, whenever an opportunity offered, and I suppose he really thought he was correct from his standpoint.

To show what Mr. A. L. Dennison thought of the claim of being the "father of American watchmaking" I will quote his own words to me, the last time but one that he visited Boston—the last time I ever saw him—and on the day before he sailed for England. We were in the front part of his brother's store, and in the course of taking leave of each other he said: "I want to say to you, Mr. Howard, that my brother talks altogether too much about what I did to establish the watch business, for I feel that I never should have accomplished it without your aid, both financially and mechanically." The facts are, we were co-workers in that enterprise, and if there were any "fathers" in the case there were two of them.

I do not wish to take any credit from Mr. A. L. Dennison, but I feel it my duty to claim what I surely know belongs to me, that is equal honor and credit in establishing the manufacture of watches in America.

I have only touched on a few points in the great un-

dertaking of creating a new industry of so complicated a nature, with so many different branches of trade, under one roof, with the energy and perseverance necessary to a full success. It would require a large volume to give its history in detail.

Respectfully yours,

EDWARD HOWARD,

Hotel Denmark.

Boston, January 22, 1895.

**The Authentic Value of the New Robinson Diamond Mine.**

KIMBERLEY, Dec. 22, 1894.—Something has occurred which is causing the De Beers directors much anxiety. In the course of his speech at the annual meeting of the company, Mr. Rhodes, the chairman, expressed the hope that they might not be called upon to buy up any more new diamond mines. The estimation in which De Beers shares have been held has been due to a widespread belief that no rival mines were likely to be found. The Free State has always been held by the experts to have within its boundaries deposits quite as rich as De Beers and Kimberley, but circumstances were against the development of the indications. Now, however, it is clear that a mine has been discovered in the Free State, the mere surface scraping at which has yielded numerous stones of large size, and of a brilliancy and purity with which, it is said, those of Kimberley cannot compare. That its prospects have satisfied the close investigation of J. B. Robinson, one of the three great diamond millionaires, that he has determined to invest largely in it and confer his name upon it may have little significance at a distance. But here it is regarded as a blow at the monopoly of De Beers, which must either buy out the concern at a fancy price or have a disagreeable rival.

You have, of course, heard from time to time much of these new mines, none of which so far have justified their pretensions. But this new Robinson diamond mine is certainly the most important of the new discoveries during the last six years, and one may await developments with interest.

The news of the discovery in Tasmania of stones resembling diamonds has necessarily excited much attention and some concern here, though it has not caused anything approaching a panic among those who regularly deal in diamonds. Australian diamonds have been long known to merchants here, but have never been considered of sufficient importance to attract the attention of buyers to any appreciable extent. They are principally remarkable for their shape, being usually as round as a pebble, and of small size, seldom exceeding one-half karat. Their extreme brittleness renders the task of cutting almost a hopeless one.

It has always been reported that a few karats of Australian diamonds are frequently ingeniously introduced into parcels of South African, but the general average of such parcels must be inferior in order that this remarkable specimen of carbon can escape detection from experts.

ST. GEORGE.

ESTABLISHED 50 YEARS.

LANDEL, BAREMORE & BILLINGS,

IMPORTERS OF

DIAMONDS,

AND OTHER PRECIOUS STONES.

FINE PEARLS A SPECIALTY.

MANUFACTURERS OF

DIAMOND JEWELRY,

IN THE LATEST DESIGNS.

Diamonds Recut in Modern Styles or Repaired on Premises.

58 Nassau Street,  
29 Maiden Lane,  
NEW YORK.

1 Tulp Straat,  
AMSTERDAM.

1 St. Andrews St.,  
Holborn Circus,  
LONDON, E. C.



TRADE MARK.

ESTABLISHED 1841.

CARTER, SLOAN & CO.,

MANUFACTURERS OF GOLD JEWELRY,

No. 15 MAIDEN LANE,

NEW YORK.

A. CARTER JR.  
A. K. SLOAN.  
C. E. HASTINGS.

GEO. R. HOWE  
WM. T. CARTER  
WM. T. GOUGH.

FACTORY, NEWARK, N. J.

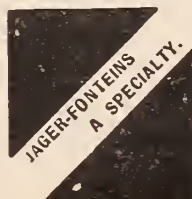

JOHN N. DISSELKOEN,

Cutler and Importer of

DIAMONDS

FACTORY:  
76 LANGEBLEEKSPAD  
AMSTERDAM

5 & 7 Maiden Lane,  
NEW YORK.

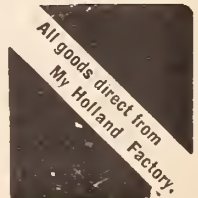

THE WESTWELL TAKES ITS WAY

# WESTERN SUPPLEMENT

## of THE JEWELERS CIRCULAR

**Chicago Office: Room 517, Inter-Ocean Building.**

VOL. XXIX.

CHICAGO, WEDNESDAY, JAN. 30, 1895.

NO. 27.

### Chicago Notes.

J. R. Davidson, manufacturers' agent, formerly with H. Muhr's Sons, is temporarily located with H. Josephs, 155 State St.

At the recent annual meeting of the stockholders of the West Chicago Masonic Association Geo. K. Hazlitt was elected president for the ensuing year.

Chas. F. Willemin, late of H. Muhr's Sons, now with Thomas G. Frothingham & Co., dropped in to visit the Chicago trade the latter part of the past week.

Morgan & Wright's new office building, N. May and Lake Sts., has had Western Union wires run in, in view of installing a system of Self-Winding Clock Co.'s timepieces.

A. F. Smith, formerly buyer for Max Meyer & Bros. Co., Omaha, will open a jobbing business there as the Reichenberger & Smith Co., about Feb. 15th. Mr. Smith bought stock here and will finish up in New York the present week.

The Madson & Buck Co., of Chicago, have incorporated with a capital stock of \$10,000 in single shares of \$100 for the manufacturing and selling of gold and fountain pens, pearl holders, silverware, etc. The promoters are Martin Madson, Fred. A. Buck and Harry T. Wilson.

The Self-Winding Clock Co., third floor Columbus Memorial building, have secured the contract for placing their system of self-winding clocks in the University School building, corner Dearborn and Elm Sts., this city. A sub-master clock will be placed in the main schoolroom, and will connect with four other clocks in different parts of the building.

The quarters at 63-65 Washington St. occupied by the Holmes & Edwards Silver Co. and the Manhattan Silver Plate Co. are undergoing an entire re-arrangement and re-decoration throughout. Twenty-five incandescent lights are being added and the World's Fair case of the Manhattan Co., filled with the latest in patterns and designs, will be prominently placed.

The Geneva Optical Co. have sold their downstairs business, including the photographic and microscope departments, to the Treleaven Optical Co., 82 State St. There will be no change in the Geneva Optical Co.'s wholesale business. Henry Burk, formerly in charge of these departments, will go to the Treleaven Co. An increased business from the first of the year is the report of the Geneva Optical Co.

A. C. Smith, president of the A. C. Smith Watch Co., has been visiting Chicago jobbers the past week with a view of putting more push into Paillard non-magnetic watches for the coming year. The development of the practical use of electricity in the west has resulted in largely increased demand for the Paillard watch. Western watchmakers are fast falling into line in the belief that a reliable non-magnetic watch is a growing necessity.

During the heavy wind storm of Monday, Jan. 21, the great semi-circular window in the salesrooms of M. S. Fleishman & Co., Masonic Temple, blew in, badly cutting W. I. Goodfellow, a salesman, about the head and hands and scattering broken glass throughout the room. The glass door leading out onto the rotunda was also smashed by the wind. Mr. Goodfellow was sitting close up to the window that was blown in, and it was owing to this nearness that he was not more seriously injured. A boarded-up window and the necessary use of electric lights in the day time were the only inconveniences the firm suffered.

Fred. L. Gregory, of the Garden City block, northwest corner Randolph St. and Fifth Ave., was issued a patent Jan. 2 for a self-winding clock that contains no spring, but whose motive power is given by the rising and falling of a weight. The magnets are placed below the clock body with curved armatures, that make a contact once in six minutes. Extending from the armatures is a lever about four inches long, at the end of which is a small weight. Just before contact the lever is in a horizontal position. When contact is made the weight end of the lever is raised to an angle of

about 45 degrees, which, in gradually falling to the horizontal position, again furnishes the motive power for running the clock. A synchronizer by Mr. Gregory is not yet patented, and no information regarding it is obtainable.

At a special meeting of the American Horological Society, Jan. 20, called to take action on the death of Aaron L. Dennison, the following resolutions were unanimously adopted:

*Whereas*, Divine Providence, in its infinite wisdom, has called from this life a gifted and highly respected member of this Society; and

*Whereas*, His associates in this Society, in which he was so eminently known and respected, have assembled to do honor to his memory and place on record this memorial of their esteem and friendship; therefore, be it

*Resolved*, That in the death of Aaron L. Dennison his family have lost a devoted husband and father and the American Horological Society a craftsman and inventor of rare genius and skill; and that we sincerely lament the loss of a craftsman so upright in all the relations of life.

*Resolved*, That we extend to the family of our deceased friend and fellow member our tenderest sympathies, and that copies of this resolution be presented to them.

The Swedish Watchmakers' Society of Chicago gave a masquerade at Phoenix Hall, 324 E. Division St., Jan. 19, when 12 prizes were given for best and odd costumes. The special prize for character costume, a fine gold watch, Waltham "Vanguard" movement and Crescent case, was won by Mrs. Emma Hasselbom. Other prizes distributed were a gent's gold watch to John Ohlson, silver cigar stand to E. Lagerquist, gold roll-plate chain to Mrs. Gunderson, silver card receiver to Mrs. A. W. Johnson, solitaire diamond ring to Mrs. L. W. Lintz, diamond and turquoise set gold ring to Miss Lettie Lundvall, pearl opera glass to Miss Anna Swanson, silver cake basket to Miss Sophia Shoberg and Miss Nilson, duplicate characters, sugar bowl and spoon holder to Miss Mary Sederblad, cologne bottle to Miss Ella Holm, and Mr. Edwin Johnson walked off with one of the ladies' prizes, a silver pin tray, for his character of the merry fisher maiden. The Society cleared about \$200, which will be placed in the sick benefit fund of the organization.



# HEADQUARTERS FOR Novelties and New Goods

• • • • AT BOTTOM PRICES.

Bag Tags—Silver.  
Bracelets and Padlocks,  
Chain Mountings—Gold.  
Chain Mountings—Rolled  
Plate.  
Coat Hangers.  
Earrings.  
Garters—Silver.  
Hat Marks—Silver.  
Link Buttons—Silver.  
Link Buttons—Gold.  
Link Buttons—Rolled Plate.



We publish no Illustrated Catalogue. Our aim is to give our Customers the Very Latest in the Market, which you cannot find in the Catalogues. Send for a selection.



Locketts and Charms—  
Rolled Plate.  
Locketts and Charms—Gold.  
Match Boxes—Silver.  
Neck Chains—Gold.  
Neck Chains—Rolled Plate.  
Pins and Neck Buckles  
Rolled Plate Watch Chains.  
1/10 Gold Vest and Dick-  
ens Chains.  
Seals, Button Hooks.  
Silver Belt Buckles.

**O. W. WALLIS & Co.,**

COLUMBUS MEMORIAL BUILDING,

113 STATE ST., CHICAGO.

## Do You Know?

THAT A FULL LINE OF THE POPULAR

FAVORITE,

PEER, . . .

ROYAL 14K.

AND PURITAN

# WATCH CASES

CAN BE SEEN AT

**BATES & BACON'S CHICAGO OFFICE?**

**H. S. NOYES, AGENT, 167 DEARBORN ST., CHICAGO.**



N. Y. OFFICE:  
11 JOHN STREET.

### Kansas City.

V. G. Cuthbert left for Chicago the last of the week.

Geo. Schafer, the mortgagee of Barney Metzger's jewelry stock, has opened up for business in the Grand Ave. store.

M. F. Barger, formerly with Woodstock, Hoefer & Co., was in town all the past week, but has returned to Chicago.

The following country jewelers were in town the past week: E. R. Matters, Neosha, Mo.; O. Kolstad, Pleasant Hill, Mo.; and H. W. W. Stalker, Junction City, Kan.

D. P. Ward, salesman for Woodstock, Hoefer & Co., has just returned from an extended trip. He expects to start out again in a few days.

Jaccard's have just placed in position a new and original idea in a watch rack for repair watches, made of iron and plate glass. It serves a double purpose, protects the watches and makes a fine display.

### Detroit.

Eugene Deimel has just issued two handsome calendars to his customers.

Frank Roehm, who has charge of Roehm & Son's watch department, is reported as being convalescent.

S. Friedberg, jeweler, Ann Arbor, Mich., announces that he will dispose of his stock of goods and return to Germany.

E. A. Dayton, of E. A. Dayton & Co., Omaha, Neb., recently passed through here with his wife en route for a visit east.

Frank Lamphere, jeweler, Lansing, Mich., has received the contract for furnishing the sergeant-at-arms and the messenger boys of the Senate with silver badges.

C. C. Thoma, Battle Creek, last week received a telegram from his brother A. W. Thoma, who is a jeweler at Kaukauna, Wis., that he had been burned out, losing everything but his bench. Mr. Thoma was formerly in business in Battle Creek.

Charles Roe, formerly with F. G. Smith & Sons, of this city, was last week visited by a large party of his Detroit friends at Pontiac, Mich., where he recently opened a finely appointed hotel. An elaborate banquet was prepared by Mrs. Roe and the new hostelry was dedicated in a fitting manner.

The finest Masonic temple in the United States was dedicated here last Thursday and as a result a great many strangers were in the city. Among the Michigan jewelers who combined business with pleasure were the following: M. D. Walton, Armada; A. T. Scattergood, Ithaca; J. S. McLachlan, Wyandotte; N. J. Eddy, Portland; George Carhart, Pontiac; M. E. Wooten, Milford; R. E. Gardner, Fowlerville; George Hamilton, South Lyons; E. N. Colby, Ypsilanti; Mr. Stone, of Stone & Carpenter, Ypsilanti; Eugene Wagner, of Wagner Bros., Monroe; S. A. Hammond, Novi; William H. Horton, Clarkston; and Mr. Gark, Imlay City. Business so far this year with the retailers and jobbers has been more satisfactory than was expected.

### Minneapolis and St. Paul.

A. E. Hall returned from a business trip to Chicago and New York last week.

C. Wahlberg, Minneapolis, has removed from 1115½ Washington Ave. S. to 1223 East Franklin Ave.

T. G. Bonnallie, Cottonwood, Minn., last week sold out his business to B. R. Cowan, who will continue at the old stand.

Out-of-town jewelers visiting Twin Cities the past week were: Lucien Diacon, Chaska, Minn.; Mr. Ingraham, Menomonee, Wis.; E. C. Bennett, Pine Island, Minn.

S. H. Clausin, of S. H. Clausin & Co., Minneapolis, who has been spending the past two months in California, accompanied by his wife, returned home last week.

Eastern jobbers and manufacturers represented in the Twin Cities the past week were: The Wm. Rogers Mfg. Co., by A. H. Clinger; L. Combremont, by William Dietz; W. R. Cobb & Co., by W. R. Cobb; The Rockford Silver Plate Co., by Mr. Wells.

The Minneapolis jobbers are getting ready for the coming Spring trade. They are buying new goods with which to stock up their traveling salesmen. Trade at present is very dull, but the near approach of Spring will no doubt stimulate trade throughout the northwest. Clarence Schlieker and J. M. Sinclair, both of S. H. Clausin & Co., started out last week on their first trip this season. Mr. Creveling, of the Reed & de Mars Jewelry Mfg. Co., and Louis Gans, of H. E. Murdock, are getting their trunks ready to start out Feb. 1st.

### Louisville.

Joe C. Kowenbergh, with Geo. H. Kettman & Co., is spending a few weeks in Bardstown, Ky.

Three negroes were arrested here for robbing the jewelry store of W. J. Scottour, Frankfort, Ky., of eight watches valued at \$500. The watches were pawned here in various shops and detectives were notified who arrested the three negroes who afterwards confessed that they had broken into the store and taken the watches.

Traveling men in Louisville, last week were: R. A. Butler, John Russell Cutlery Co.; Fred J. Foster, Unger Bros.; G. Hoffman, Ansonia Clock Co.; Thos. H. Ryland, J. B. Bowden & Co.; A. Fisher, Kraus, Kragel & Co.; Jno. S. Jepson, Byron L. Strasberger & Co.; Arthur Totten, Rogers & Bro.; Mr. Tinker for Wm. B. Durgin; M. Goldsmith.

The Mossberg Mfg. Co., Attleboro, Mass., are offering rolling mills of the very latest design which embody several ideas never before introduced in these machines. A new automatic drop press, simple, easy of adjustment and operation, and capable of the rapid production of uniform work is another article which the trade will appreciate. Full descriptive circulars may be had on application, also copies of the firm's new 1895 catalogue, showing many new tools for jewelers and silversmiths.

### Cincinnati.

The failure of C. F. Dufeu, Chillicothe, for \$22,000 caught several Cincinnati people.

B. Frankenstein will enter the jobbing arena. He is looking for quarters in the Carew building.

Hilward Aubray Goldberg is the new heir to the house of Samuel Goldberg, of Amberg & Goldberg.

By order of the Court the stock of the assigned Pure Aluminum Co. is offered for sale this week at public auction.

Peter Henry, the well known watch case repairer, is wearing a button with a watch dial face presented to him by Mr. Duncan, of the American Waltham Watch Co.

E. & J. Swigart, importers and dealers in jewelers' supplies, are as busy now as at any time last month. An immense amount of tools and trays has gone out of this house in the past three months.

Harry Walton, of the Wadsworth Watch Case Co., is in the east sending in good orders. The new flat center recently introduced is much admired. The No. 6 size is especially in much demand. Many new designs have been brought out this year.

A man entered Anthony Wahl's jewelry store at 8th and Carr Sts. and asked to see some watches. While examining from a tray displayed, the proprietor turned to bring out some more, when he grabbed three gold watches and ran out. He made his escape.

Bloom & Phillips, manufacturers' selling agents, have added a handsome line of Ferdinand Bing & Co.'s novelties in porcelain, bric-à-brac, bronze, etc. They have also the agency of Deitsch Bros., fine leather specialties, which they sell direct from the factories.

The travelers ready to go out are: Joe Hellebush, of C. Hellebush; John Othill and Wm. Pflueger, of Jos. Noterman & Co.; Eugene Froh Meyer, of D. Schroder & Co.; Chas. Rauch, of Stern & Co.; W. Higgins, H. C. Pfaffle, of O. E. Bell & Co.; Chas. Eickhardt, of Albert Bros.; I. Linndorf, of Henry Hahn & Co.

The manufacturers of jewelry, watches, etc., were conspicuous for their absence at the great manufacturers' convention, in Cincinnati last week. Only local manufacturers were present. The Homan Silver Plate Co., Wadsworth Watch Case Co., Jos. Noterman & Co., Gus. Fox & Co., and Michie Bros., were on the register. The object of the gathering was to secure new markets and better legislation.

Wm. Oskamp, of Oskamp, Nolting & Co., as a member of the Cincinnati Board of Trade, was active in pushing the enterprise to a successful issue. The formation of a National Association of Manufacturers gives every manufacturers' association an opportunity for membership to co-operate for these advantages now in motion.

I. Warshauer, wholesale jeweler, 33 Bedford St., Boston, Mass., has assigned, with liabilities about \$20,000 and assets not stated.

**San Francisco.**

George Greenzweig is in the east for five weeks.

E. C. Marliave, traveler of Phelps & Miller, has departed on a southern trip.

Fred. Davis started north last week for Nordmann Bros. He is the first traveler out.

Fred. Lipman has moved from Kearney St. near California St., to Kearney near Bush Sts.

R. Kocher, of San José, and Frank Lewis, Pleasanton, were in town buying goods recently.

W. H. Crins, ex-president of the Gorham Mfg. Co., of Providence, is in town with his wife and family.

The engagement is announced of Walter P. Treat, with Shreve & Co., and Miss Mamie C. Hayes, a daughter of Thos. R. Hayes.

The Lombard Loan Co. have opened another store on Market St. near 5th St. The Kearney St. store will also be run by the same corporation.

The Lombard Loan Co. have been incorporated with a capital stock of \$200,000 by J. L. Salomon, A. Mendelsohn, Edith Salomon and Moses H. Lichtenstein.

A. Markewitz, who went out of business

last Summer, has returned from the east where he has settled up some property left to him. He is now opening a jewelry store in Kearney near Clay St.

**Pacific Coast Notes.**

F. B. Spiridon has filed a civil suit in Los Angeles against jeweler A. N. Polymath, to secure an antique bracelet valued at \$50 which was left with Polymath to be repaired and which has not been returned.

A. A. Lazarus, Arcata, Cal., has failed. His total indebtedness is \$3,073.53, and assets including stock and fixtures are only \$650. H. Reilinger, Oakland, is the principal creditor, he holding notes amounting to \$1,838.35.

Herman Welisch recently secured judgment for \$5 against jeweler J. C. Wahlen, San Diego. The latter had decided to leave town and one night not only removed all his stock from his store which adjoined Welisch's but even removed the paper from the partition wall separating the stores. This wonderful act of economy was the cause of the damage suit.

F. C. Chase has been arrested in Spokane, Wash., charged with stealing the contents of a traveling jeweler's trunk. By

mistake E. E. Meyers' trunk was left outside the Union depot at night, and upon being looked for was missing. The next morning it was found where it had been left the day before, but was empty. The crime was traced to Chase. Eight gold watches and a miscellaneous assortment of jewelry were stolen.

**ARE YOU AN ENGRAVER?** } WANT  
**ARE YOU LEARNING?** } A GOOD  
 } BOOK?

Over 2200 Different Monograms.



More than  
6000  
Combinations.



Book indexed, so you can find any 2 or 3 letter design in 10 seconds' time, also contains specimens of Old English and Script Text, Ornamental and Cipher Monograms. If book is not found **satisfactory**, money will be refunded. Sent prepaid on receipt of \$1.00. References, any Chicago jobber.

Ask for new Illustrated Circular on Engravers' Type.

SOLD BY CHICAGO JOBBERS,

**W. H. DIETZ,**  
115 Dearborn Street, CHICAGO.



**GENEVA  
OPTICAL CO.,  
CHICAGO.**

CATALOGUES.

- PART 1—General Catalogue of Optical Goods.  
" 2—Microscopes and Accessories.  
" 3—Photographic Cameras, Stocks and Supplies.  
" 4—Thermometers, Barometers and Meteorological Instruments.

**PRESCRIPTION WORK** Made with Promptness and Accuracy.

**OCULISTS' or OPTICIANS' OUTFITS.** Trial Cases. Ophthalmoscopes. Lens Measures.

CORRESPONDENCE SOLICITED.

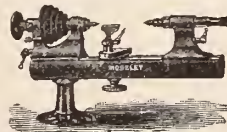

One of the best of the very best.

QUALITY IS THE STANDARD OF VALUE FOR WHICH WE COMPETE.

"THE MOSELEY."

"A Bread Winner" for the watchmaker We furnish you good lathes and chucks, while the other fellow furnishes the wind.

MOSELEY & CO., Elgin, Ill.



No. 2 Moseley Wire Chuck has length, strength, accuracy.

MORE ADVANTAGES—LESS COST.



CHICAGO  
ROCKFORD

**Watchmakers' Institute**

211-20 WALNUT ST., ROCKFORD, ILL.

Write for New Terms. \_\_\_\_\_ :

G. D. PARSONS, Principal

**PARSONS' SCHOOL**  
—FOR—  
**WATCHMAKERS,**  
PEORIA, - - - ILL.

Send for Circular and Terms.

**PARSONS & CO.**

**G.A. WEBSTER**

42 & 44 Madison St., Chicago, Ill.

**Manufacturer,**

AND WESTERN AGENT FOR

E. G. WEBSTER & SON, of Brooklyn, N. Y.

A. F. TOWLE & SON CO., of Greenfield, Mass

DIAMOND CUTTERS and POLISHERS looking for desirable and permanent positions should apply direct to

**FOX BROS. & CO.,**

68 and 70 West 4th Street,

CINCINNATI, OHIO.

**Trade in Watches With Japan.**

WASHINGTON, D. C., Jan. 25.—The Swiss vice-consul at Yokohama, Dr. Paul Ritter, has recently sent an elaborate report on the commerce and industries of Japan to his Government. The following extract will prove of interest to the American watchmaking and jewelry trade:

"Watches.—There has been great excitement among importers and exporters, owing to the projected establishment of a great American watch factory at Yokohama. After several vain efforts made by American speculators to sell the old machines brought over from the United States to Japan by a stock company, for which they had asked 1,000,000 yen, they lately succeeded in selling them to a Japanese stock company, together with a considerable number of unfinished watches. The capital stock of the company is stated to be 300,000 silver yen, of which 150,000 yen have been subscribed by the originators themselves. The factory will be established at Osaka, and I will be able next year to report on its results.

"The Swiss watch industry will not be encroached upon to any extent by this undertaking. As to clocks, hardly any of them

have heretofore been imported from Switzerland, and, as to watches, the Japanese do not like factory-made works. If the Japanese people had been willing to buy such, they could long ago have bought the cheap American factory watches instead of the expensive Swiss, and the following figures will show how little chance the former have to increase their sales in Japan.

"The total imports for 1892 and 1893 were 89,318 watches, worth 431,918 yen, and 103,747 watches, worth 523,126 yen, respectively. The increase in number was 14,429, or about 16 per cent., and the increase in value, 91,298 yen, or about 21 per cent.

"The countries below participated in these figures as follows:

Countries.	1892. Number.	1893. Number.
Switzerland.....	80,447	86,713
France.....	5,751	10,243
United States.....	2,816	2,406
Germany.....	287	3,694
Great Britain.....	9	691
Other countries.....	8	...
Total.....	89,318	103,747

"From the United States, there were further imported 333 plated or rolled watch

cases and 106 gold cases, and from Switzerland parts of watches worth 9,077 yen, which items were probably required for watches finished in Japan.

"The imports of watches to Japan increased in 1893, as against 1892, by about 16 per cent. in number, and about 21 per cent. in value. The increase in value is not due to the importation of higher-priced watches, but to the advanced rate of exchange in the second half of 1893."

**Jeweler W. U. Watson and Wife Charged With Fraud.**

BUFFALO, N. Y., Jan. 23.—In the county court Hattie E. Watson has begun an action against William U. Watson and others to foreclose a \$1,200 mortgage on property on the east side of Richmond Ave., 132 feet north of Lexington Ave. William H., E. Fen and Edwin H. Gardner are named as defendants, they claiming to have a lien on the premises. In their answer to the proceedings they make a charge of dishonesty against Mr. Watson. Watson is the jeweler at 289 Main St. The plaintiff is his wife. The Gardners claimed they contracted with Watson to construct the house on the Richmond Ave. property and say they were to receive \$3,564. They declare that \$955.73 is still due them.

The mortgage in question was executed Jan. 23, 1894. The Gardners charge that at that time Watson was the owner of \$10,000 worth of jewelry stock, that he was indebted for that amount and confessed judgment for \$5,000 in favor of certain creditors. The Gardners charge that these creditors and the Watsons entered into a scheme to prevent Watson from being dispossessed of his jewelry store. They also allege that part of the scheme was the execution of the \$1,200 mortgage, and they ask that it be declared null and void and that the premises be foreclosed to satisfy their lien.

In his answer Mr. Watson denies that anything wrong or dishonest has occurred, and says he can prove it.

Fire broke out about 8 o'clock on the night of Jan. 13, in the basement of the Green-Smith Co.'s jewelry store, 713-715 16th St., Denver, Col. The flames were confined by the department to where they originated, but smoke and water did considerable damage to the stock on the floor above. The loss will be about \$1,000

**\$3.00**      **FORMERLY**      **\$6.00**

Ivory and Enamel Miniatures  
Best Workmanship.



Original Inventor and Patentee of  
**Miniatures**  
—OR—  
**Gold and Silver.**  
PATENTED November 12, 1889

**LEON FAVRE, 107 EAST 26TH STREET, NEW YORK.**

**MATHEY BROS., MATHEZ & CO.**  
21 & 23 MAIDEN LANE, N. Y.  
BRASSUS, SWITZERLAND.  
MANUFACTURERS OF  
THE SMALLEST,  
THE THINNEST,  
THE NEATEST AND  
THE BEST  
**SPLITS.**



10 Size.      SOLE AGENTS FOR      10 Size.  
**JAQUES LECOULTRE • RAZORS.**

**AIKIN, LAMBERT & CO.,**  
CHICAGO BRANCH: 103 State Street.      No. 19 MAIDEN LANE, NEW YORK.

Manufacturers and Exporters  
Gold Pens, Holders, Pencils,



Toothpicks and Novelties

**MERCANTILE**



**FOUNTAIN PEN.**



# L. STRAUS & SONS,

IMPORTERS AND MANUFACTURERS.



China, Pottery and Glassware, 42, 44, 46 & 48 Warren St. and 116 Chambers St., N. Y.  
PARIS, CARLSBAD, RUDOLSTADT, LIMOGES, STEINSCHONAU.



## THE LATEST NOVELTY IN BIBLE BOOK-MARKS.

MOUNTED WITH  
Sterling Silver or Gold Ornaments,  
ON ALL SILK RIBBONS, 8 1-2 INCHES LONG  
WITH APPROPRIATE QUOTATIONS  
**WOVEN IN THE SILK.**

Nine different quotations. Ribbons in the following colors: Purple, black, white and lilac. Can be sold profitably at a popular price. Made only by

**STONE BROTHERS,**  
535 Broadway, NEW YORK.

When you buy  
Cut Glass  
You want the best!  
That which bears our  
Trade Mark  
Has no superior  
And will prove profitable and satisfactory.



**T. B. CLARK & CO., INC.,**  
860 Broadway, N. Y.,  
Factories. HONESDALE, PA. N. E. Cor. 17th St. & Broadway.

**Philadelphia College of Horology**  
Is not the largest but is the finest school in the country. A practical school to learn watch-making, engraving, and jewelry repairing. One tuition pays for all branches. Send for prospectus.  
**F. W. SCHULER, PRINCIPAL,**  
1213 Filbert St., Philadelphia, Pa.  
Write for particulars of our corresponding course.

**JACOT & SON**  
IMPORTERS AND MANUFACTURERS OF  
**MUSICAL BOXES**  
39 Union Sq. New York.

## AMERICAN WATCH TOOL CO.

ESTABLISHED 1872.  
INCORPORATED 1894.



THE  
**Webster-Whitcomb**

GROWS IN POPULARITY.

PRICES AS LOW AS CONSISTENT WITH QUALITY.

Ask your Jobber for Price List of 1895, or write to us at  
**Stoney - Batter Works, Chymistry Dist., Waltham, Mass.**

**SAFES FOR JEWELERS.**  
**MOSLER, BAHMANN & CO.,** 518 BROADWAY NEW YORK.  
Patent Fire and Burglar Proof Safes.

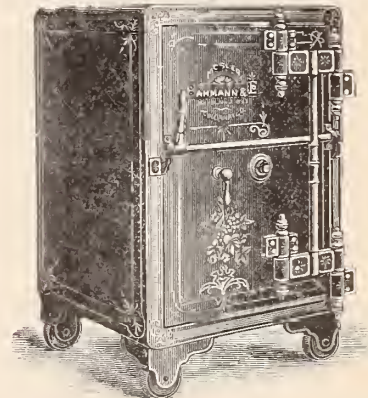

Large Assortment Always on Hand.  
Send for our **Representative**.  
Special Safes to Order.  
**Jewelers' Safes a Specialty.**

IMPORTERS OF  
**DIAMONDS.**

JOBBERS IN  
Watches, Jewelry, Chains,  
NOVELTIES ETC.

Latest Designs. Lowest Prices.

**AIKIN-LAMBERT**  
**JEWELRY CO.,**

19 Maiden Lane, New York.  
CHICAGO BRANCH 103 STATE ST.

# FERDINAND BING & Co.,

106 GRAND ST., N. Y.  
COR. MERCER.

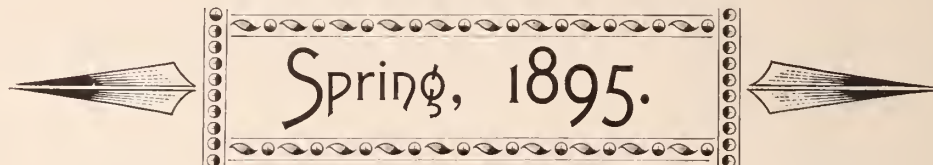

ALL THE  
NEW STYLES  
IN

## CLOCKS

ALL THE LATEST  
CREATIONS IN

## BRONZES

ALL SIZES  
AND SHAPES  
OF

## LAMPS

WITH GLOBES TO MATCH.



ALL THE  
NOVELTIES  
JUST OUT IN

SÈVRES  
VASES,

DRESDEN AND



VIENNA GOODS

AND

RUSSIAN  
SPECIALTIES.

NOW READY FOR  
INSPECTION.



New  
Furniture  
and  
Marble  
Statuary.





THE TRADE MARKS ON PORCELAIN AND POTTERY.

PART IV.—MARKS ON SEVRES AND AMERICAN KERAMICS—MARKS ON AMERICAN CUT GLASS.

SEVRES ware has borne many marks depending upon the date of manufacture. The collection below shows almost all the principal changes since the date of the first mark, 1745.

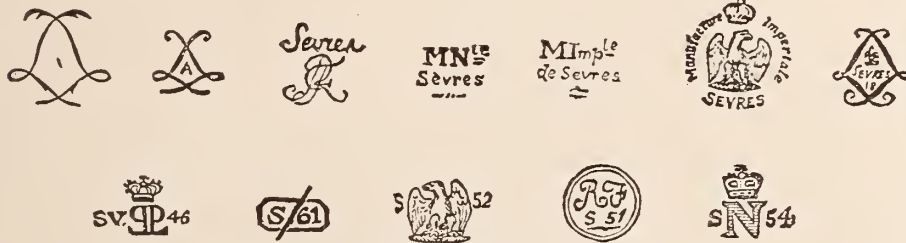

SOME MARKS SEEN ON SÈVRES.

The mark on Rookwood pottery consists of a unique combination of the letters R



ROOKWOOD.

and P. The manufacturers are the Rookwood Pottery Co., Cincinnati, O.

The foregoing marks and those illustrated in the three preceding numbers of THE CIRCULAR having represented practically all of the principal pottery lines handled by the jewelry trade, the trademarks of the chief American brands of an equally important line, cut glass, are here appended.

TRADE MARKS ON CUT GLASS.

C. Dorflinger & Sons use the cut as the trademark for the cut glassware which they



C. DORFLINGER & SONS.

manufacture at their factory in White Mills,

Pa. The New York salesrooms are located at 36 Murray St.

Below is the trademark used by that branch of the Pairpoint Mfg. Co., which was formerly the Mt. Washington Glass Co., New



PAIRPOINT MFG. CO.

Bedford, Mass., on their rich cut glass. The ware is to be seen at the company's various salesrooms, 46 Murray St., New York; 224

Wabash Ave., Chicago, Ill.; 220 Sutter St., San Francisco, Cal.; and Temple building, Montreal, Can.

T. G. Hawkes & Co., Corning, N. Y., use



T. G. HAWKES & CO.

the above mark on the rich cut glass which they manufacture.

This cut identifies the cut glass of L.



L. STRAUS & SONS.

Straus & Sons, the product of their factory in Hoboken, N. J. The ware is displayed

at their showrooms, 42-48 Warren St., New York.

The mark below is known to the trade as belonging to the cut glass of T. B. Clark



T. B. CLARK & CO.

& Co. (incorporated), Honesdale, Pa., whose ware rooms are at 860 Broadway, New York.

The cut glass of the J. D. Bergen Co. shows the cut below as their trademark. It is



J. D. BERGEN CO.

manufactured at Meriden, Conn. The New York salesrooms are at 42 Murray St.



J. S. O'CONNOR.

The cut glass of J. S. O'Conner, whose trademark is here illustrated, is manufactured at Hawley, Pa. The entire product of this factory is controlled by Geo. Borgfeldt & Co., 18, 20 and 22 Washington Place, New York.

Other manufacturers of cut glassware are the Meriden Silver Plate Co., Meriden, Conn., whose New York salesrooms are at 30 E. 14th St. and 133 Wabash Ave., Chicago. This company have not as yet adopted a trademark for their cut glass products.

## The Connoisseur.

(Continued from page 75).



TRADE MARK.

A. A. VANTINE & CO.'S TRADE MARK ON ORIENTAL WARES.

The finest of the Oriental Porcelains controlled by A. A. Vantine & Co., 877 Broadway, New York, bear the trade mark of this firm which consists of crossed Chinese and Japanese flags, and Star and Crescent as shown above.

### Past Year's English Pottery Trade.

SO far as the pottery trade is concerned the past year cannot be described as of a remarkable character, says the *Pottery Gazette* (London) for January. Although disputes have arisen between employer and employed in other industries, and which have seriously interfered with trade relations, nothing of the kind has happened amongst the Staffordshire potters. The differences that have arisen to the surface have been amicably settled. But whilst congratulating the capitalist and laborer in this respect we cannot but express regret that the selling prices have continued so low and that no steps have been taken by the manufacturers generally to raise the standard of their lists. We have before pointed out that

it is impossible, or at least next to impossible, for the individual manufacturer to raise his prices single-handed. For the welfare of the potting community it is imperative, as it appears to us, that united action should be taken in the matter by the manufacturers, and, if they think it advisable, we see no reason why the operatives should not be taken into their confidence.

So many complaints have been made during the year as to the lowness of selling prices that the question will have to be faced in the earlier months of the year, and the sooner it is looked at squarely the better will it be for all parties concerned. It would appear now to be generally recognized that the present position of affairs is not due solely to the effects of foreign competition, but that it is largely owing to the action of manufacturers themselves in underselling each other. This being the case, the question of raising the standard of the marketable value of ware is much simplified, since the natural deduction is that it rests largely with the manufacturers themselves.

Even under adverse conditions the Staffordshire potter has continued to make progress, and it may be safely asserted that he is in a better condition to meet the demands of the market at the end of the year 1894 than he was at its commencement. The dark clouds which have hovered over the industry have not prevented him from extending his means and powers of production, and this is strikingly observed on a

visit to the potteries. On every hand are observable new factories, or factories in process of construction, whilst old establishments are being enlarged and improved. It may be said that the Factory Acts are responsible for this; well, they may be to a large extent, but we contend that our manufacturers now recognize that many of the old methods of manufacture have become obsolete, and that their factories must be built in a different form than they used to be, if they are to meet the demands which they expect in the future to be made upon them. It is almost universally felt at the present time in the Staffordshire potteries that the demands upon their producing power will rapidly increase, and that it is essential that manufacturers should be in a position to meet them. In other words, the industry, whatever its achievements in the past may have been, is still regarded as but in its infancy. And there would seem to be much reason for this hopeful spirit when we look around upon the world, and the continual expansion of its markets, and remember at the same moment the utilitarian nature of the products of the potter's craft.

Increased facilities have been provided during the past year for the educational advancement of the sons of the potter, and these, so far as we can learn, are most highly appreciated. It has for a number of years been felt that the highest educational advantages should be placed at the command of our sons of toil, and especially

## THE JEWELRY TRADE

Will find our stock of Oriental Importations replete with the most advanced novelties in folding and open fans, fine Japanese porcelains for bric-a-brac and table use, Japanese bronzes in statuary and figures, Oriental lamps and hanging lanterns, India and Chinese solid silverware, white metal novelties, and many other lines especially adapted for a high class jeweler's display.

The trade are cordially invited to inspect our wholesale lines.

### A. A. Vantine & Co.

LARGEST JAPANESE, CHINESE, TURKISH, PERSIAN, EGYPTIAN, AND INDIA HOUSE IN THE WORLD.

Wholesale: 18, 20 and 22 East 18th St. Retail: 877 and 879 Broadway, N. Y.



TRADE MARK.



# IT PAYS TO IMPORT.

EXAMINE OUR

## HIGH CLASS PORCELAINS AND POTTERIES.

Art Novelties. Fine Bric-a-Brac.

CHINA BOUDOIR CLOCKS.



THREE-QUARTERS OF ACTUAL SIZE.

**Most Attractive**  
 And Salable Goods ever put on  
 the Market.  
 Dainty and useful pieces of  
 Bric-a-Brac.  
 Best American Movements.  
 Can be retailed at \$2.00 each  
 and upward.  
 Do not fail to see this line.

**New Styles**  
 and Decorations.

“St. Cloud,” “Imperial,”  
 “Monarch,” “Carmencita,”  
 “Majestic,” “St. Elmo,” “Prin-  
 cess,” “Savoy,” “Pompadour,”  
 “Mignon,” “Gladstone,” “Bi-  
 jou,” “Fountainblau,” “Em-  
 pire,” “Alhambra.”

Our large sample collections afford Jewelers and Art Dealers a splendid opportunity to secure the choicest of goods, and unequalled European connections enable us to quote the lowest prices. SUPERB ASSORTMENTS. ACTUAL NOVELTIES.

Every buyer should see our lines of

**CLOCKS, BRONZES, MARBLE STATUARY, DRESDEN AND FLORENTINE FURNI-  
 TURE, RICH CUT GLASSWARE, ETC.**

# GEO. BORGFELDT & Co.,

18, 20 & 22 WASHINGTON PLACE,

COR. GREENE ST., NEW YORK.

with reference to art, education, and technique. Undoubtedly as the years roll by, we shall see, as we have in the past, the influence which such advantages conferred upon the rising generation have upon the future productions of the ceramic art.

As to the foreign and colonial markets a decrease is observable for the 11 months ending November. In 1893 the total amount of the exports was 1,712,232*l.*, whilst for 1894 they only reached 1,475,555*l.* It must, however, be stated that the exports for the month of November show a very satisfactory increase—the figures being, 1893, 145,790*l.*, and 1894, 161,344*l.* This increase, it must be clearly understood, is largely due to the shipments to the United States, consequent upon the tariff reduction. And whilst mentioning this matter it may be as well to remind the readers of the *Pottery Gazette* of the strenuous exertions which are being made in the States to cause a reimposition of the tariff which has been ceded. We can hardly expect, however, that they will succeed when we remember the severity of the lesson which was taught the American citizen by the existence in "all its glory" (?) of the McKinley Tariff Act. But to resume, trade with Germany continues to increase steadily and also with France. The exports to Brazil are also rising, but trade with the Argentine Republic is scarcely worth recording. A decline is also noticeable in the British East Indian and North American markets.

**Queries by Circular Readers.**

AUNVASSE, Mo., Jan. 18.

Editor of THE JEWELERS' CIRCULAR :

Is there a law as to how long a jeweler has to keep a watch after repairing it?

JAMES DAVIS.

ANSWER:—As you are a subscriber to THE CIRCULAR we presume you keep the journal on file. If you refer to the issue of Nov. 21, 1894, page 25, you will find among the editorials, one bearing pertinently upon the subject.

NEWARK, N. J., Jan. 10, '95.

Editor of THE JEWELERS' CIRCULAR :

As a subscriber to THE JEWELERS' CIRCULAR I ask you for a little information: 1. Please tell me how much copper is there added to silver to make it sterling? 2. What makes a good hard silver solder? 3. What makes a good easy silver solder?

S. MITCHELL.

ANSWER: Here are two recipes for composing standard or sterling alloy:

1. Fine silver, 18 dwts.; shot copper, 2 dwts.
2. Fine silver, 1 oz.; shot copper, 2 dwts., 6 grains.

As regards solders, some recipes published specify the use of brass; this, however, is an unreliable and unsatisfactory component, because its constituents vary largely at times. It is better, therefore, that the silversmith should add the several constituents composing brass, or separate metals, as in that case he knows what compound he has.

Best Hard:—Fine silver, 16 dwts.; shot copper, 3 dwts. 12 gr.; spelter, 12 grains; or best hard, fine silver, 1 oz.; shot copper, 4 dwts. 9 grs; spelter, 15 grains.

Easy:—Fine silver, 14 dwts.; shot copper, 4 dwts. 12 grs.; spelter, 1 dwt. 12 grains; or, easy, fine silver, 1 oz.; shot copper, 6 dwts. 12 grs.; spelter, 2 dwts. 4 grains.

By the way, why does Mr. Mitchell not refer to his copy of "Workshop Notes," in which he will, beside the recipes detailed above, find a large number of others from the plenitude of which he can select those best suited to his wants? The subject, "Silver, its alloys, modes of treatment, etc.," is treated at full length in the book, and will be found on page 145, *et seq.* THE CIRCULAR is bold to assert that very few technical books on so comprehensive a plan have ever been issued.

One of the prettiest show windows that Muncie, Ind., has seen was at Klein's jewelry store recently. In the window the name H. C. Klein was made of glass tubes through which red fluid and air continually moved. The air and fluid ran up, down and crosswise, and a person soon became dizzy by close observation of the movements. In the cellar was a large boiler half filled with the fluid and the remainder air. There was an equal pressure on each and alternately a drop of fluid and air was forced into a rubber tube and continued its course through all of the tubes. Armstead Klein had been experimenting on this piece of work for two months.

**"MOTHER GOOSE" STICK PINS.**

PATENTED NOVEMBER 6 AND DECEMBER 4, 1894.



Bo Peep.



Old Mother Goose.



The Frog that would a wooing go.



Tom the Piper.



Her diddle diddle, The cat and the fiddle.



Hot Cross Buns, one a penny two a penny.



Little Jack Horner.



Humpty Dumpty.



There was an old woman tossed up in a basket.



Correct in style. Bound to sell.

The best selling line of Stick Pins to date.

Elegant in finish. Prices Right.



ENAMELED SHIELDS.

The Latest out. Engraved Silver and Roman finish. Be sure and see them.



The Newest Fad.

Elegantly Engraved and Enameled.



Beautiful Designs.

Prices that defy Competition.



Finished in Silver and Roman.

Put up in our best style.



SHEPHERD'S CROOKS.

New Designs. Engraved Silver and Roman finish. Be sure and see them.

**CZARINA BUCKLE COLLARETTES**

The Latest Novelty.

**CZARINA BUCKLE STICK PINS.**

Don't Fail to see them.

GEO. F. GREENE & CO., Manufacturing Jewelers, 111 and 113 Point Street, PROVIDENCE, R. I.

# HINRICHS & CO., 29 and 31 Park Place, NEW YORK.

## IMPORT AND STOCK

SAMPLES FOR SEASON OF 1895 READY.

Useful and Art Goods for Jewelers.

CHINA LAMPS. ALL SIZES AND PRICES.



ELABORATE line of French China, consisting of Chocolate Pots, Cracker Jars, Salad Bowls, Fancy Trays for Brushes and Combs, Toilet Sets, Picture Frames, Tea-Caddies, Bon-Bons, Chocolate Sets, Etc.

A very large line of A. D. Chocolate, Coffee, Tea, and Bouillon Cups and Saucers in French, Bohemian and German Chinas.

Cut and Engraved Bohemian Glassware in Bowls, Sugars and Creams, Etc.

A number of new lines of Pottery and Bric-a-Brac from England, Austria and Germany.

Tall Bohemian Glass Bouquet-Holders for Chrysanthemums and long stem cut flowers, in Heavy Cut Crystal, Engraved and Gilt; also in Bohemian Colored Glass, plain and decorated, some with Cupid and Watteau designs. Send for Catalogues.



### CODDING BROS. & HEILBORN,

North Attleboro, Mass.

Makers OF

## QUICK SELLING NOVELTIES

In Sterling Silver.

NEW YORK OFFICE—C. A. Vanderbilt, 178 Broadway.  
CHICAGO OFFICE—F. A. Buck, 103 State Street.

### ENAMELERS

OF GOLD, SILVER AND PLATED JEWELRY, Enameled, Plain and in Colors.

ALSO OF SOCIETY EMBLEMS, YACHT AND COLLEGE FLAGS. All Varieties of Painted Enamel Work.

### S. S. WILD & SON,

179 Eddy Street, PROVIDENCE, R. I.

Correspondence Solicited. Telephone Connection.

THE AMERICAN KNIFE AND SCISSORS SHARPENER.



TWO-THIRDS SIZE.

PAT. FEB. 23 '92.

For Table Use.

Special Inducements to Jobbers

... Manufactured only by the

## MOSSBERG WRENCH CO., ATTLEBORO, MASS.

Makers of Novelties in Silver and Hardware.

### Practical and Handsome.

A Silver Plated Knife and Scissors Sharpener, retailing at a popular price. Perfect in action, nothing to wear out. Cutting discs of finest hardened steel. An ordinary sharpness or a RAZOR EDGE can be acquired in a few moments.



TWO-THIRDS SIZE.

FOR DESK USE.

- FOR SALE BY
- Benj. Allen & Co., Chicago, Ill.
  - F. M. Sproehle & Co., "
  - G. A. Webster, "
  - L. Straus & Sons, New York.
  - E. G. Webster & Son, "
  - Oskamp, Nolting & Co., Cincinnati, O.
  - Baldwin, Miller & Co., Indianapolis, Ind.
  - Eliassof Bros. & Co., Albany, N. Y.
  - Thos. Long & Co., Boston, Mass.
  - Smith & Patterson, "
  - Dame, Stoddard & Kendall, Boston, Mass.

FALKENAU, OPPENHEIMER & Co.

TRADE MARK **DIAMONDS**  
40 MAIDEN LANE NEW YORK.

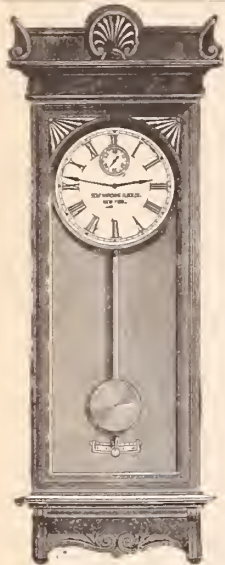

**SELF WINDING CLOCK CO.**

NEW YORK-CHICAGO.

HALL CLOCKS,  
OFFICE CLOCKS,  
Synchronized Time Plants.

No Winding. Corrected Hourly

BY TELEGRAPH SIGNALS OVER WESTERN UNION TEL. CO.

Wires from U. S. Naval Observatory, Washington, D. C.

General Office:  
26 BROADWAY, N. Y.

Branch Office:  
Columbus Memorial Bldg. Chicago.

Sold by all whole-  
sale dealers at manu-  
facturer's price.

A. N. CLARK & SON  
PLAINVILLE  
CONN.

Manufacturer of the Celebrated  
**LOOP WATCH KEY.**

The Best for the Price in the World.  
CROSBY'S JEWELING TOOLS IMPROVED.

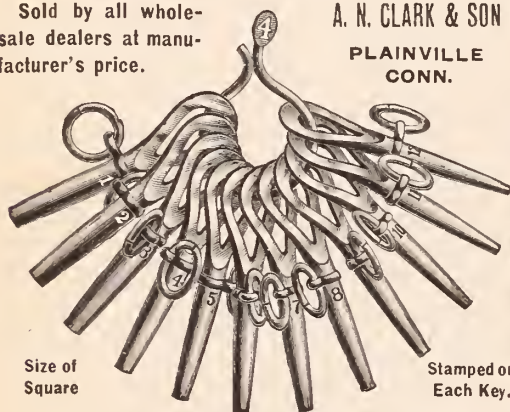

Size of  
Square

Stamped on  
Each Key.

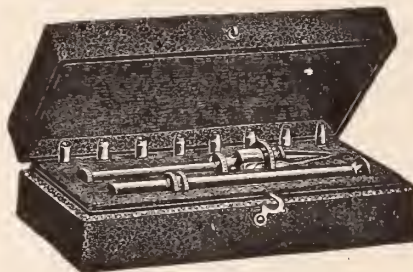

Will quote royalty or price for the manufacturing of articles of real worth.

**B. & W. B. SMITH,**  
220 W. 29th St., New York.

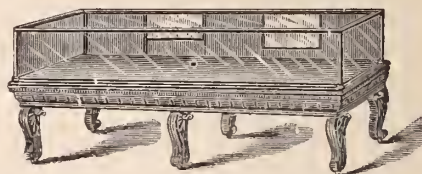

Improved Dust-Tight Counter Cases,  
Perpendicular Sliding Doors.

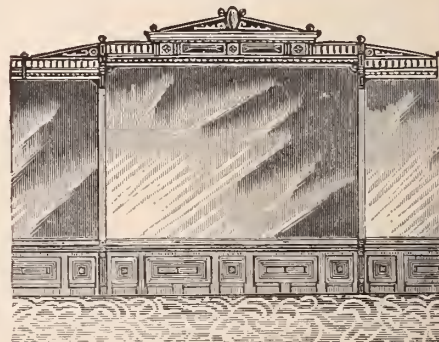

Improved Dust-Tight Wall Cases.  
Furnished with Improved Shelving and ar-  
ranged for Electric Lighting.



.. OUR ..  
**SPECIALTY**

The Largest Stock of  
CHIMING  
AND  
STRIKING  
HALL CLOCKS

ever shown.

**Chas. Jacques**  
CLOCK CO.,  
22 Cortlandt Street,  
NEW YORK.

**DIAMONDS.**

**C. COTTIER & SON,** IMPORTERS OF  
PRECIOUS STONES,  
14 MAIDEN LANE, NEW YORK.  
C. A. RICHARDS, Agt. 151 Weybosset St., Prov., R. I.

**FANCY GEMS.**

**PRESCRIPTION WORK.**  
**QUEEN & CO.,**  
1010 Chestnut Street, PHILADELPHIA.  
SEND FOR PRICE-LIST AND ORDER FORMS.

**U. S. SMELTING & REFINING WORKS,**

Sweep Smelting and Assaying, Platinum in Plate and  
Wire. Chemically Pure Copper. Ore and Bullion  
Assays a specialty.

Highest prices paid for old gold and silver.  
Sole manufacturers of Phoenix Flux  
and Eureka Alloy.

**M. WOLLSTEIN.** 25 John St., New York.

**Diamond Polishing Machines.**

We build these machines complete with latest improve-  
ments also polishing wheels, tongs, dous, weights,  
shafting, belting, ventilating fans, gear-cutting, die blanks,  
etc., We do general repair work on jeweler's machinery.

**THE ARTHUR CO.,**

General Machine Works,  
86 JOHN STREET, NEW YORK.

**WOOD & HUGHES,**  
STERLING SILVERWARE MANUFACTURERS

New York Agents for the Derby Silver Co  
**FINE QUADRUPLE PLATED WARE,**  
No. 16 JOHN STREET, NEW YORK.  
206 Kearney St., San Francisco, Cal.  
**HASKELL & MUEGGE,** Agents.

SEND FOR PRICE LISTS

**JEWELERS' MACHINERY**  
W. W. OLIVER, BUFFALO, N. Y.

DRAW BENCHES ETC.

**S. F. MYERS & CO.,**

Manufacturing and  
WHOLESALE JEWELERS,  
1895 Issue, No. 39.

**OUR ROYAL CATALOGUE**

Illustrates all that is new, unique  
and desirable in  
everything that pertains to jewelry.  
600 pages, size of this publication  
Free to dealers.

SEVEN DOUBLE FLOORS.  
TWENTY-TWO DEPARTMENTS.

Myers Buildings, 49-50 Maiden Lane,  
33-35 Liberty St., New York.

**DIAMONDS** Importers and Cutters. **L. & M. KAHN & CO.,** 172 Broadway, Cor. Maiden Lane, N. Y. **DIAMONDS**

**IT PAYS** TO KEEP IN TOUCH WITH TRADE AFFAIRS. For 4c. a Week will do it. **Subscribe.**  
THE JEWELERS' CIRCULAR.







