







Staatliche Uhrmacherschule

IV 1166

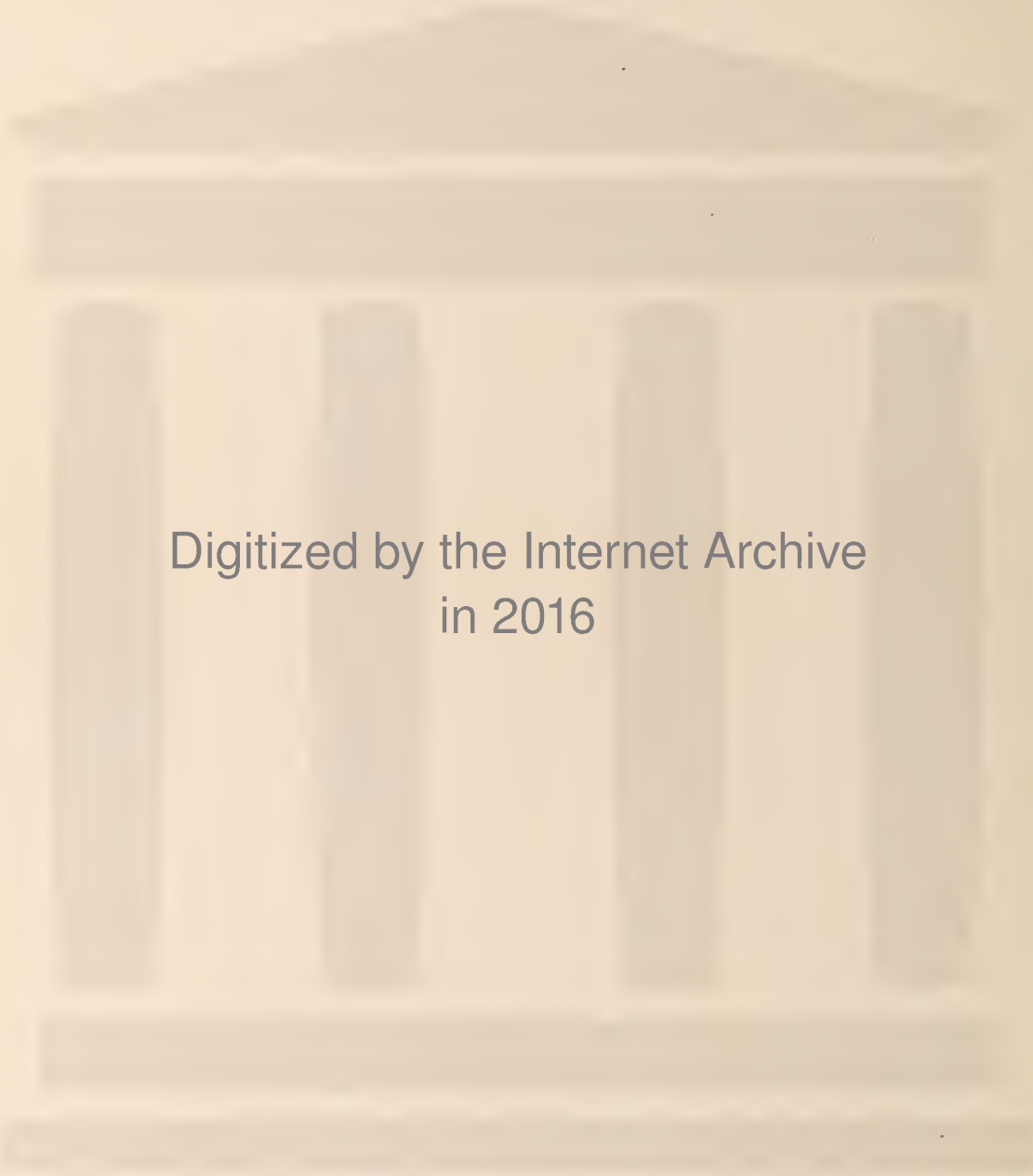

Digitized by the Internet Archive  
in 2016

[https://archive.org/details/jewelerscircular00unse\\_20](https://archive.org/details/jewelerscircular00unse_20)

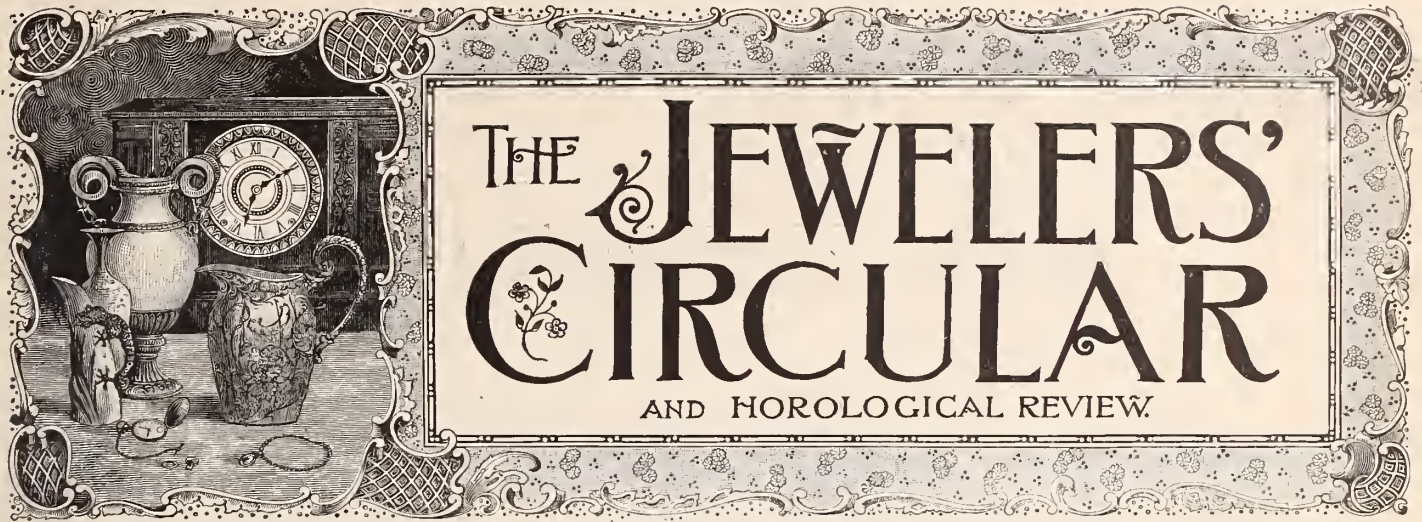

Copyright by THE JEWELERS' CIRCULAR PUB. CO.

189 Broadway, New York.

Entered at the Post Office in N. Y. as second-class matter.

VOL. XXVIII.

NEW YORK, WEDNESDAY, FEBRUARY 7, 1894.

NO. 1

### THE SILVER ANNIVERSARY OF THE JEWELERS' CIRCULAR.

WITH this number THE JEWELERS' CIRCULAR celebrates its Silver Anniversary. During a quarter of a century this journal has weathered the storms that have struck the commercial and industrial world and it is but meet that the publishers should emphasize the success of their journal with an edition which, as an artistic and literary work, will stand as a monument in the history of jewelry trade journalism. At the date of the founding of THE JEWELERS' CIRCULAR, few of the special journals that now wield such commanding influence in nearly all lines of activity, were in existence, and of these perhaps not a dozen are published at the present day. The recognition of its own achievements which this issue evidences is a fitting acknowledgment of the importance of the profession of trade journalism. The numerous kind expressions of continued success received from the trade since the announcement by the management of THE CIRCULAR of their intention to publish a Silver Anniversary Edition, have been gratifying to them not only as an appreciation of their own endeavors, but of those of the men now long since departed, who founded the journal, worked unceasingly to make it a recognized adjunct of the jewelry and cognate industries, and who left a heritage that has proved a source of pride and honor to their followers. We take this opportunity to extend collectively a

cordial thanks to all these well wishers of this journal. THE JEWELERS' CIRCULAR owes its origin to D. H. Hopkinson, who from a

journalistic venture so new and strange as the launching of a paper to be devoted exclusively to the interests of the jewelry trade, characterized Mr. Hopkinson in his every action during life. He was born in Sheffield, England, in 1840. His family was one of prominence and influence in the community, but he labored under the disadvantages of being a younger son in a country where the principle of primogeniture is established, and he therefore had to make his own way in the world. The goal of ambitious youth then as now was America, and he came hither with intelligence, capacity, energy, perseverance and a few dollars as his sole capital. At the breaking out of the rebellion, Mr. Hopkinson entered the service of the Government as clerk to E. K. Cooley, acting paymaster in the navy, whose friendship he had gained. At the close of the war he returned to New York and successively held positions in the business departments of various publications, notably *The Evening Mail*. In this branch of activity he developed great capacity and was highly successful.



D. H. HOPKINSON.  
FOUNDER OF THE JEWELERS' CIRCULAR.

a few years after its establishment till his death on Friday, July 25, 1884, was its sole proprietor and directing spirit. The quality of bravery which urged him to make a

In 1869 he conceived the idea of establishing a journal to be devoted to the watch and jewelry interests, and the THE JEWELER'S CIRCULAR was the result. During his experience on the daily newspapers he had won the friendship of many members of the trade, and though the reception given to his



# Gorham Manufacturing Company SILVERSMITHS,

SILVER  $\frac{925}{1000}$  FINE.



VIEW OF THE PAVILION OF THE GORHAM MANUFACTURING COMPANY AT THE  
WORLD'S COLUMBIAN EXPOSITION, CHICAGO, 1893,

CONTAINING THE

Largest, most varied and valuable Exhibit of Silverware  
in all of its important branches

EVER DISPLAYED AT ANY EXPOSITION IN THE WORLD.

List of separate awards granted to the  
**GORHAM MFG. CO.,**

... BY THE ...

World's Columbian Exposition,

CHICAGO, 1893.

(Containing a greater number of awards than given to any other single exhibit at the "World's Fair.")

- |   |  |
|---|--|
| <p>No. 1. Artistic display as a whole.</p> <p>2. Sterling Silver-Ware.</p> <p>3. Fine Art Pieces.</p> <p>4. Special Silver and Glass Dessert Service.</p> <p>5. Silver Dinner Service, Repoussé Chased.</p> <p>6, 7, 8. Silver Hollow-Ware, 3 awards.</p> <p>9. Special Exhibit of Prize Pieces.</p> <p>10. Special Exhibit of Silver Gilt-Ware.</p> <p>11, 12. Enamelling on Silver, 2 awards.</p> <p>13, 14. Painting on Enamel, 2 awards.</p> <p>No. 15. Translucent Enamel.</p> <p>16. Champlevé Enamel.</p> <p>17. Cloisonné Enamel.</p> <p>18. Blown-in Glass.</p> <p>19. Silver Mounted Cut-Glass and Crystal.</p> <p>20. Silver Deposit on Glass and Pottery.</p> <p>21. Ecclesiastical Goods.</p> <p>22, 23. Ecclesiastical Silver and Gold, 2 awards.</p> <p>24. Ecclesiastical Electro-Plate.</p> <p>25. Ecclesiastical Brass.</p> | <p>No. 26. Statuary in Silver, Bronze and Brass.</p> <p>27. Bronze Statuary.</p> <p>28. Bronze Castings.</p> <p>29. Knives, Forks, Spoons, &amp;c.</p> <p>30. Silver Flat Ware.</p> <p>31. Toilet Ware.</p> <p>32, 33. Electro-Plated Ware, 2 awards.</p> <p>34. Medal Work, in Gold, Silver and Bronze.</p> <p>35. Hard Wood Chests.</p> <p>36, 37. Gold and Silver Mounted Leather Goods, 2 awards.</p> <p>No. 38. Carved Leather.</p> <p>39. Silver Mounted Card Cases and Purses.</p> <p>40. Silver Mounted Pocket Books.</p> <p>41. Silver Mounted Traveling Bags.</p> <p>42. Silver Mounted Hand Bags.</p> <p>43. Silver Mounted Portfolios.</p> <p>44. Silver Mounted Cigar Cases.</p> <p>45. Silver Mounted Leather Cases.</p> <p>46. Silver Mounted Umbrellas.</p> <p>47. Silver Mounted Canes.</p> |
|---|--|

**Gorham Manufacturing Company,**  
**SILVERSMITHS,**

Broadway and 19th Street, = = New York.

BRANCH OFFICES:

23 Maiden Lane, New York,  
 137 State Street, Chicago,  
 118 and 120 Sutter Street, San Francisco.

43 West Street, Boston,  
 37 Avenue de l'opera, Paris,  
 Works at Providence, R. I.



idea would have discouraged most men he found a few firms who accepted it and gave him their support. His first office was in connection with the printery of Donovan & Londergan, 269 Pearl St., who printed THE CIRCULAR for 21 years. Canvassers were employed to solicit the trade and special writers on horological and other trade topics were retained. When THE CIRCULAR was once established, its high commercial tone and general character soon commended it to the trade. Subsequently was purchased a struggling little paper, started a year before THE CIRCULAR, called *The Horological Review*, which was merged with that journal, and the double title was given rise to. Thus THE JEWELERS' CIRCULAR AND HOROLOGICAL REVIEW dates back to 1869. In 1873 the paper passed into the hands of Mr. Hopkinson as sole proprietor, and he shortly afterwards took an office at 42 Nassau St., which speedily became a social headquarters, prominent dealers of Maiden Lane and visitors from out-of-town dropping in habitually to have a chat with the affable proprietor.

It was the founder's policy to give the journal a high tone and to make it instructive to those in the trade and to those about to enter it. THE CIRCULAR reflected the character of its proprietor, and it therefore championed right at all times, and vigorously denounced all frauds and shams. Mr. Hopkinson, though a young man, exercised an elevating and salutary influence upon his associates in the editorial and business departments, and being full of resources himself, he was quick to act upon suggestions and to award the full meed of praise to him who made them. He was an indefatigable worker, being at his desk early and late. Though born an Englishman he became a thorough American in thought and action. In private life Mr. Hopkinson was one of the most genial and companionable of men. Humor was a prominent characteristic of his nature, but he did not use it as a weapon to stab sensitiveness, for he was of an exceeding sympathetic and charitable temperament.

On July 25, 1884, in the 44th year of his age, Mr. Hopkinson passed away, lamented deeply by the entire trade, for he had been a man who endeared himself to all who came in contact with him by his many generous and manly traits.

SETH W. HALE.

At the death of the founder, his widow desired to dispose of an interest in the property

and Seth W. Hale organized among his friends The Jewelers' Circular Publishing Co., which purchased of Mrs. Hopkinson a controlling interest in THE CIRCULAR. Mr. Hale was chosen president and general manager, which position he held till the time of his death.

Mr. Hale had spent a half century in active business life, as an able, intelligent, energetic man. His experience in the jewelry trade dated back practically to his boyhood, when he was an employe in the Jerome Clock Co.'s factory. He later went on the road to sell clocks and materials, and subsequently had charge of the company's New York office. About this time his brother,



SETH W. HALE.

MANAGER OF THE JEWELERS' CIRCULAR FROM 1884 TO 1889.

C. E. Hale, went to New York, and with Seth W. formed a jewelry business in partnership. This business did not last long, and S. W. Hale became a traveler for Fellows, Wadsworth & Co. While on the road he formed a strong friendship with Aaron Carter, of Carter & Pierson, which lasted till his death. Somewhat later, these gentlemen became associated in business, the firm becoming Carter, Pierson & Hale; later Carter, Hale & Co. The firm is now Carter, Sloan & Co.

In 1867 Mr. Hale retired with a competence and went to Europe. On his return he made the mistake of going into the stock brokerage business in Wall St. He subse-

quently returned to the jewelry trade, becoming a partner in 1873 in Mulford & Co., the firm name being changed to Mulford, Hale & Cottle. The members of the firm were L. J. Mulford, present general manager of THE CIRCULAR, Mr. Hale, and Shubael Cottle, of the S. Cottle Co. of the present day. Mr. Cottle retired in 1876, and the firm continued as Hale & Mulford. Six years later L. J. Mulford retired and S. W. Hale & Co. succeeded. This firm continued two years, at the end of which time Mr. Hale assumed the management of THE CIRCULAR.

One who knew him personally has said: "He was one of the kindest, gentlest natures I ever knew; a man of strictest integrity, with a keen sense of business honor, and who never wilfully wronged another or intentionally wounded his feelings." It was during his regime that the present spacious offices of THE CIRCULAR at 189 Broadway were taken. Mr. Hale died on Dec. 11, 1888, at the age of 67 years. He was succeeded in the management of THE CIRCULAR by his former partner, L. J. Mulford, who had been connected with the journal for some time previous and had an extended acquaintance in the trade. Under this gentleman's administration of the affairs of the paper, THE CIRCULAR has seen some radical changes all in the line of progress.

#### THE FIRST NUMBER OF THE JEWELERS' CIRCULAR.

The first number of THE JEWELERS' CIRCULAR would not be considered a pretentious affair from the stand-point of present day journalism. It consisted of eight pages, 12 X 17 inches, the letter press being printed on paper which would be looked upon as common today, though it was then of a finer quality than usually obtained among journals of its kind—news and book paper in those days being fully 100 per cent. higher in price than at the present time. The reproduction of the first page of this initial number, seen in this article, is about two-thirds size of the original. To demonstrate the unvarying success which has been THE CIRCULAR's from its inception, by making a comparison between the initial number of Mr. Hopkinson's enterprise and the voluminous numbers of later years, it is proper to compare it with the later monthly issues, when THE CIRCULAR was often composed of as many as 150 pages, over 100 of which were devoted to advertisements; or a comparison may be made between the eight pages a month in 1870 and the 48 pages to 64 pages a week of the



# THE FIVE MOST DESIRABLE PATTERNS



TRIANON.—Pierced.

LOUIS XIV.

MAZARIN.

ROCOCO.

CUPID.

**Dominick & Haff,** Makers of Wares in Sterling Silver.  
 Broadway and Seventeenth St., Union Square, N. Y.

ESTABLISHED 1821.



present time. But THE CIRCULAR in 1870 was in its infancy, and everyone will recognize the propensity of all infants to be small. The journal grew into a strong and vigorous manhood, in which we find it to-day.

Glancing over the advertisements which Vol. 1, No. 1 contained, we are forcibly impressed with the many and sad changes that even a quarter of a century of fleeting time brings about in every field of activity howsoever limited. On page 1 were the

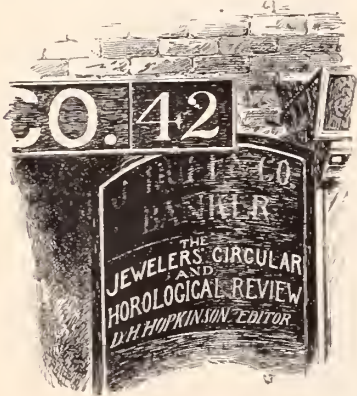

AN OLD SIGN ON NASSAU ST.

announcements of Smith & Hedges, of 1 Maiden Lane, now Alfred H. Smith & Co., 182 Broadway, and Wm. S. Hedges & Co., 170 Broadway, the original firm having dissolved in 1878; Collier & Lu Gar, composed of H. N. Collier, who had been with Randel & Baremore, and J. B. Lu Gar, the son of a well known house decorator, failed after a short existence; Priest & Fuller failed, while all the members of Merrill, Fitch & Allin are gone to the country from whose bourne no traveler returns, the only remains of the business being an almost extinguished sign on the building at 15 John St.; Philip Bis-singer is still a prominent exponent of the trade at 22 John St.; Quinche & Krugler, once prominent watch importers, are both dead.

On page 2, the American Watch Co., now the American Waltham Watch Co., printed a card to the trade, it being the first advertisement which Mr. Hopkinson received for his new paper. The company were then located at 182 Broadway, and they averred that "no watches retailed by the company." The Waterbury Clock Co., then located on the same spot as to-day, though their number was 4 instead of 10, announced themselves as dealers in every kind of clocks and clock materials; while Munsell & Thompson claimed themselves to be the sole manufacturers of Queen's patent portable forge bellows for jewelers, dentists and blacksmiths; Ball, Black & Co., 565-567 Broadway, now Black, Starr & Frost, 251 Fifth Ave., were importers of Jurgensen, Nardine, Jacot, Saltzman, Nicoud, Gérard, Frodsham, Peardon, Gording, Rugenstein, Harrison and Taylor watches and movements, and Tiffany & Co., then at 550-552 Broadway, were importers of watches, jewelry and bronze goods, mantel and clock sets, writing desks, book racks, statuary, etc.

On page 3 were a goodly representation of Philadelphia advertisements: Carrow, Crothers & Co., wholesale manufacturers of fine jewelry, are long out of business, John Carrow being dead, and Thos. J. Crothers being in the plumbing business; Butler, McCarty & Co., composed of Franklin Butler, Edward McCarty and H. O. Hurlburt, were the predecessors of McCarty & Hurlburt, now H. O. Hurlburt & Sons; R. Brunswick, importer of watches, failed, and Hildeburn & Bro., one of the largest jobbing firms in the Quaker City, are dead; G. S. Lovell is now the Geo. S. Lovell Clock Co., agents for the Seth Thomas Clock Co.; Wm. B. Warne & Co., of which firm D. F. Conover was a member, are succeeded by D. F. Conover & Co., and L. A. Scheer, deceased, is succeeded by his sons Louis A. Scherr and Geo. W. Scherr and C. H. O'Bryon, as L. A. Scherr & Co.; A. Picard also had an advertisement on this page, as did Ephraim & Isaacs, both now dead.

The editorial page was No. 4, while page 5 contained the announcement of W. A. Hayward, whom we cannot trace; Geo. A. Jones & Co., manufacturers of regulators; J. F. Hopkinson & Co., lately gone out of business; Leonard Decker, subsequently in business with W. R. Cattelle, as Cattelle & Decker, Mr. Decker being deceased, and Mr. Cattelle being a salesman for Henry E. Oppenheimer & Co.; Th. Block & Bros., 20 Maiden Lane, now Adolphe Schwob, 4 Maiden Lane; H. G. Soule & Co., 17 Maiden Lane, now out of business for many years; Waaser & Lissauer, importers, 52 Nassau St., subsequently Lissauer & Sondheim, 12 Maiden Lane, now Lissauer & Co.; H. A. & G. M. Church, 176 Broadway, out of business; Samuel Strauss, importer of watches and jewelry, 11 Maiden Lane, deceased; Moore & Horton who remained at 11 Maiden Lane till their retirement in 1892; J. Garson, importer, 60 Nassau St., deceased; J. B. Laurençot, 61 Nassau St., and later at 33 Maiden Lane, deceased, and the business is now closed; John Dickinson, glazier's diamonds, 64 Nassau St.; Graham & Clark, lapidaries, the business still continued at 63 Nassau St., by Graham & Co.; F. Kroeber, dealer in American clocks, 10 Cortlandt St., now the F. Kroeber Clock Co., 360 Broadway; Charles Francke & Co., fine jewelry and ornamental hair work, 165 Broadway, now out of business; and Freund, Keller & Co., 15 John St., importers of watches and dealers in a general line of jewelers' goods, dissolved in April, 1870, the business existing to-day in the firms of Max Freund & Co., 8 Maiden Lane, and Keller & Untermeyer Mfg. Co., 192 Broadway.

Page 6 contained no advertisements, while page 7 contained one-half page announcements of Adams, Chandler & Co. and Giles, Wales & Co. The former firm, long out of business, advertised a patent tilting and revolving ice pitcher and stand. John P. Adams, brother of Caleb Cushing Adams, of Brooklyn, recently deceased, till the change in the administration of the municipi-

pal affairs of the City of Churches, was Commissioner of Public Works. Giles, Wales & Co., the name of the selling department of the United States Watch Co., of Marion, N. J., located at 13 Maiden Lane, are long since out of business. Giles, Bro. & Co., Chicago, were the western agents.

Of the dealers who advertised on page 8, Paul A. Brez, importer of watches, 23 John St., William Ruhl, a prominent importer of coral and other jewelry then fashionable, 2 Maiden Lane, above Wheeler, Parsons & Hayes, Stein & Brother, importers of watches, 66 Nassau St., have departed this life; Julien Gallet, importer of watches, 26 John St., was succeeded by Julien Gallet & Co., 1 Maiden Lane, now Jules Racine & Co., 180 Broadway; Albert Lorsch & Co., 16 Maiden Lane, now at No. 37, then were manufacturers of patent accommodating spectacles and eyeglasses; Tomlinson & Tyler, watches and jewelry, 20 Maiden Lane, long since dissolved, T. C. Tomlinson having an office with the late J. D. Yerrington, at 176 Broadway; Sig'd Veit, importer, 16 Maiden Lane, is still seen in the "Lane;" J. E. Spencer & Co., manufacturers of fine jewelry, spectacles and eyeglasses, 16 Maiden Lane, are now the Spencer Optical Mfg. Co. at No. 15, but do not manufacture jewelry, their extensive business being in the optical line exclusively; Ve. J. Magnin, Guédin & Co., 652 Broadway, were a very prominent firm, Mr. Guédin being the second president of the New York Jewelers' Association; they were general importers of French goods adapted to the jewelry trade, and are now all out of business; Warren, Spadone & Co. are out of the jewelry business, Messrs. Warren and Spadone being interested at present in the Para Rubber Co.; J. T. Scott & Co., 11 Maiden Lane, were then associated with Scott, Barrett & Co., Pittsburgh, Pa., now G. B. Barrett & Co.; Mr. Scott is dead, the present firm of J. T. Scott & Co., 4 Maiden Lane, being continued by his sons, James T. and Clement S., but no longer being connected with the Pittsburgh house; M. Fox & Co., lapidaries, 1 Maiden Lane, where they are still located; the Co. was then Charles Schmidt, who was lost when the *Schiller* foundered off the Scilly Islands; A. Wallach & Co., manufacturers of gold chains, 11 Maiden Lane, now at No. 30; J. A. Brown & Co., Providence, R. I., the predecessors of the Ladd Watch Case Co., then manufactured lockets and George W. Ladd's "patent stiffened or filled gold watch cases;" Mr. Brown died about a year or more ago; J. S. Birch, 16 Maiden Lane, then manufactured self-adjusting watch keys, as the firm do to-day, though Mr. Birch is long since deceased; Bryant & Bentley, 12 Maiden Lane, made 300 patterns of hard solder rings, stamped and warranted 16 karats fine, also 18 karat bracelets, Etruscan and solid enameled sets, masonic jewelry, etc., while their successors, M. B. Bryant & Co., 10 Maiden Lane, confine themselves to an unlimited production of rings.



# The Jewelers' Circular.

A MONTHLY JOURNAL,

Devoted exclusively to the interests of the Manufacturers and Importers of Jewelry, Watches, Clocks, Silver-Ware, Plated Goods, Etc., Etc.

VOL. I.

NEW YORK, FEBRUARY 15TH, 1870.

No. 1.

## DIAMOND MINES.

The Diamond is the purest form of carbon, an elementary substance of great importance both in organic and inorganic chemistry. They are found throughout the range of the Ghats in India, but chiefly at Golconda, in Borneo, Brazil, California and recently in Africa. Of those recent discovered Diamond producing regions we propose to speak of in detail. The Brazilian mines are said to furnish about fifteen pounds weight of stones every year, of which not more than nine hundred carats are fit for jewelers.

The primitive form of a Diamond is the regular octahedron, or two four-sided pyramids of which the faces are equilateral triangles applied base to base. It is a non-conductor of electricity and may be heated to whiteness in a crucible without injury, although it burns in the open air about the melting point of silver, as was demonstrated in Tuscany by exposing the stone in the focus of a large lens. In England the celebrated Chemists, Boyle, Tennant and Sir Humphrey Davis demonstrated the same fact.

The art of cutting and polishing Diamonds is supposed to have originated in Asia at some unknown period, but was accidentally discovered in 1456 by Louis Berquen, of Bruges, by rubbing two of the precious gems together. The various forms into which they are cut are called the *Brilliant*, the *Rose* and the *Table*.

The chief application of the Diamond is for ornamental jewelry, but there are other interesting applications of this gem in the useful arts.

The geological locality of the Diamond seems to be in diluvial gravel, and among conglomerate rocks, consisting principally of quartz mixed with ferruginous sand, called *casuelito* in Brazil.

The loose earth containing them lies always a little way beneath the surface of the soil, towards the lower outlet of broad valleys, rather than upon the ridges of the adjoining hills. It is said that stones surrounded by a greenish crust are of the first water, most limpid when cut.

India has been celebrated from the most remote antiquity as the country of Diamonds, the principal mines being those of Golconda and Visapur, extending from Cape Camorin to Bengal, at the foot of a chain of mountains called the *Orissa*, which appear to belong to the trap rock formation. In all this district the stones are found enveloped in an earthy crust which is first broken in pieces then washed in basins and spread out in a smooth spot to dry. The Diamonds sparkling in the sun can then be easily picked out.

They are also found in the interior of Borneo, on the banks of the river Succadan and upon the peninsula of Malacca.

Their first discovery in Brazil was in 1728, near Sorrodo Frio, where the ground has a perfect resemblance to that of the East Indies.

The most celebrated mine is that of Mandarga, on the river Jigitouhonha, which is nine feet deep; but the water is drawn off by sluices during the dry season. The gravel bed is then removed and piled up on the banks in little mounds of sixteen tons each. During the rainy season this earth is washed beneath a long shed in slime boxes by squads of negroes containing two hundred hands in each.

In the small streams which flow into the Jigitouhonha are found the blue Topazes and Crysoberyls. The districts of India and Abaité produce the largest Diamonds, yet not so pure a water as those of Sorrodo Frio. On the banks of the Rio Pardo, a mountain torrent, there is another mine, the ground presents many irregular strata of friable pudding-stone rock while the Diamonds have a greenish-blue tinge.

The largest Diamond yet found in Brazil, now in the Crown of Portugal, weighed one hundred and twenty carats. The mines have brought the Government from the year 1730 to 1814, 3,023,000 carats; being an average of 36,000 carats yearly. There the Diamond, Ruby, Sapphire and Opals, sparkle in their native splendor, yet so much greater is the annual sum received from the single article of coffee that it exceeds the results of eighty years yield of the mines.

In California the few Diamonds which have

been discovered were found in washing gravel for gold. The largest does not exceed two carats, and we question if the yield will ever amount to much.

Turning our face to the South Pole, we gaze upon a newly discovered region which bids fair to rival the old mines.

The recent discoveries of Diamonds in South Africa have created considerable excitement among the jewelers of Europe, and it is not to be wondered when we learn over three hundred stones have been discovered in the limited area of one farm. The Diamond mines are located in the Orange Free State, a Dutch Republic in the northern interior of South Africa. The adjacent country is settled by farmers in sections of 8,000 acres of land, beyond these tracts is an immense amount of land as yet unexplored in the Valt and Orange River district inhabited only by natives who seek the precious stones for barter with the Boers. The region of Diamonds is near Hope Town, the character of a land being mostly plain or gently rolling like our Western prairies. The largest Diamond as yet found is called the Star of South Africa, but we regret that there is no authentic data of its weight or form. It was sold by a native medicine man to a Dutch farmer for five hundred sheep, and he disposed of it in Port Elizabeth for the sum of £11,500. At this town it was exhibited for some time and thence sent to Paris, the owner meanwhile refusing an offer of £20,000.

Another large stone brought over \$5,000 gold at public auction, while many small ones varying from a half to three carats in the rough are being sold daily. They bring from £8 to £50 for a three carat.

The farms upon which these gems are found do not bring a very high figure as the excitement has just commenced and no systematic operations have been inaugurated. From all reports it would seem that a new field has been opened up for the supply of small Diamonds that bids fair to last for years. If the region were not so distant we should doubtless see as great a rush of fortune seekers as those who flocked to California in the golden days of '49.

We will inform our patrons from time to time of the progress of new discoveries.

## THE SPECIFIC GRAVITY OF GOLD

It is well known that the Specific Gravity of Gold is very great, but very few persons have a clear and definite idea of what Specific Gravity is. Even in these days of science and education there are very confused notions prevalent about the celebrated pound of lead and pound of feathers, a brief explanation of the theory of Specific Gravity may not be interesting to our readers.

What we call *weight* is really only the attraction of the earth exercised in a different degree upon different substances, and is otherwise known as Gravitation. It is evident that, in order to ascertain the relative power of Gravitation of various substances, we must take some unit of comparison, and for the purpose of estimating the Specific Gravity of all solid bodies, water has been uniformly adopted. Accordingly, if we were to take a cube of gold and compare its weight with an exactly equal bulk of water, we should certainly be able to discover its Specific Gravity; but as this course would be extremely difficult in practice, another method has been adopted of arriving at the desired result. If you immerse a solid body in water it will displace a mass of water exactly equal to itself. And no matter how heavy the body may be, the water has a much greater tendency to support it, or to cause it to float, as we say, than the atmospheric air.

This tendency, then, counteracting Gravitation, makes the substance lighter in the water than in the air, and the amount of lightness or negative weight is exactly equal to the amount of heaviness or positive weight of a bulk of water equal to the bulk of the substance immersed. Hence is deduced the rule for taking the Specific Gravity of a solid, which consists in weighing it first in air then in water, and dividing its weight in air by its loss in water.

## SMITH & HEDGES,

No. 1 MAIDEN LANE;

Corner of Broadway,

NEW YORK.

Importers and Manufacturers of

# DIAMOND GOODS,

EXCLUSIVELY.

Diamonds and Precious Stones, Set and Unset, sent on approval to Dealers in all parts of the Country, on receiving from them satisfactory References to New York Houses.

## COLLIER & LU GAR,

Importer of

# DIAMONDS AND PRECIOUS STONES,

And Manufacturers and Dealers in

# WATCHES AND FINE JEWELRY,

Sole Agents for the NEW YORK WATCH COMPANY'S

STEM AND KEY WINDING WATCHES.

No. 176 BROADWAY,

H. N. COLLIER, (late with Randal & Baremore)  
J. B. LU GAR.

New York.

## Priest & Fuller,

Importers and Dealers in

English, Swiss and American

# WATCHES,

DIAMONDS,

JEWELRY,

SILVER-WARE, &c.

13 MAIDEN LANE,

New York.

E. A. Priest,  
F. A. Fuller, Jr.

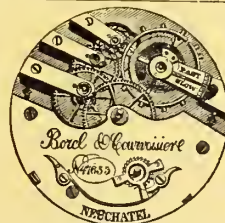

The celebrated  
**Borel & Courvoisier's**  
NICKEL  
Movements,  
IN  
**GOLD**  
AND  
**SILVER**  
CASES,

Are Manufactured, Imported and for sale Wholesale only by  
**QUINCHE & KRUGLER,**  
8 & 10 John Street,  
Sole Agents for the U. S.,  
Up Stairs.

The Celebrated  
**Borel and Courvoisier Nickel Movements,**  
Of which the above cut is a fac-simile, are manufactured  
and imported in Gold and Sterling Silver Cases,  
and for sale wholesale by  
**QUINCHE & KRUGLER,**  
8 & 10 JOHN ST., (Up Stairs.)

## Merrill, Fitch & Allin,

Manufacturers of

# Fine Jewelry,

19 JOHN STREET,

Near Broadway.

W. B. Merrill,  
D. M. Fitch,  
Geo. Allin.

New York.

## PHILIP BISSINGER,

Importer of

# Diamonds, Pearls, Corals,

AND PRECIOUS STONES,

And Manufacturer of

# DIAMOND JEWELRY,

No. 13 JOHN STREET,

New York City

Agent for the Sale of BOHEMIAN GARNET GOODS



The reading matter evidenced a primitiveness of knowledge of trade requirements, though it was absorbing to the readers of the times. The news gathering facilities were in an embryonic state, and therefore the editor waxed facetious in his accounts of happenings, as for instance:

A Cleveland jeweler, by the name of Wade, slandered a lady clerk in his employ, by the name of Rosa Barton. Rosa Waded into him and got a verdict of \$5,000. She won't take store pay.

Again:

Diamonds are becoming more and more scarce and expensive every year, on account of the giving out of old mines. New mines do n t seem to be discovered in proportion as the old ones give out. What will our belles do when no more are found at all?

Scanning the pages we note that General McClellan was recently presented with a \$300 watch; that the prospect of the coming Spring was most encouraging, employment being abundant and money plentiful; that the large fortunes made during the war had created a "new social demand for jewelry and gold and silver wares;" that the first

discoverer of the important law respecting springs was "Huggens;" that an ancient silver mine known as the "white pebble pit" had recently been discovered; that for every day wear plain sets of brooch and earrings with yellow gold pendants were very stylish, the latest novelty being enameled tracery in relief on colored gold; that the Byzantine were the only mosaics worn; that never were earrings worn so large; that the opera chain was much used.

As the trade began to welcome THE CIRCULAR more and more warmly with the passing of the months, and the publishers acquired a clearer insight into and a more positive knowledge of the desires of the trade in respect to a journal published in their interests, experienced writers on various topics were engaged, and THE CIRCULAR soon became and has since remained the recognized authority on technical matters pertaining to the jewelry and kindred trades.

It would be a vain attempt to endeavor to

review the achievements of THE CIRCULAR. From the outset the policy of the journal has been to provide for its readers articles original and instructive. That this policy was a wise one the long career of the journal and the high appreciation in which it is held by the trade, afford ample proof. As an essentially technical trade journal when in its monthly form, it was the *vade mecum* to thousands of apprentices who, through the constant study of its pages, became proficient workmen. In its present weekly form, now at the threshold of its fourth year, THE CIRCULAR is acknowledged as the most representative journal devoted to the interests of the jewelry and cognate lines, being a thoroughly equipped newspaper, while it retains many of the technical and artistic features that made the older monthly famed in the field of journalism. The publishers feel proud of the record of their journal and elated at the character of the current issue, which is an earnest of their capabilities.



### THE CLOCK THAT SOT ERGIN THER WALL.



EACON SKINNER'S  
clock wuz tall  
Straight sot up ag'in  
ther wall  
An' I had ter git er  
chair  
Fer t' see th' sojers  
there  
What kem out an'  
marched before  
Er captain who popped  
out a door  
Every time she struck,  
an' thin

Turned an' popped right back ag'in.  
I wuz jist a little mite  
En thet clock wuz greatest sight  
Sottin' up ergin ther wall  
Mighty fine an' mighty tall,  
An' th' sojers what marched by  
In their red coats, caught my eye  
In er way thet sojers now  
Couldn't catch it anyhow.  
Well our folkses moved away

An' ther years lagged on 'fore they  
Went back visitin' some aunts  
Takin' me, an' th' fust chance,  
Fast ez my two legs could race  
I jest made fer Skinner's place  
Fer ter feast my eyes onct more  
On them sojers; but ther floor  
Er th' ceilin' had grow'd small  
An' ther clock ergin ther wall  
Want so shiny, an' my face  
Reached up to th' captain's place  
An' ther sojers to my sight  
Want so party er so bright  
An' I didn't need er chair  
Fer to see 'em marching there.  
I wuz disappointed some  
But I watched 'em when they cum  
Cuz they wuz old friends uv mine  
An' altho' they didn't shine  
In their red coats an' want tall  
An' ther clock ergin ther wall  
Kinder dwindled an' looked sad  
'Long with me, still I wuz glad  
Fer ter see 'em onct ergin

Marchin' roun' an' reun'—en thin  
Ma o' visitin' got through  
An' went hone, an' I went too.  
Years an' years had passed away  
I wuz gettin' on, an' gray,  
Whin ergin in Skinner's hall  
Ther ol' clock ergin ther wall  
Met my sight—I'm sorry now  
I a-seed it; can't tell how  
Suthin' tother want jist right  
Didn't 'mount ter shucks in height  
Sojers, little bits o' wood,  
Squeakin' round; ther captain stood  
'Thout his arms before th' door  
Tryin' as in days before  
Ter look prim; but lost ther knack—  
Wish I hadn't er gone back  
An' could 'member it so tall  
Sottin' up ergin ther wall.

Geo. W. Stevens

THE "Pairpoint"

# MFG. COMPANY,

FACTORIES:

New Bedford,  
Mass.

MAKERS OF

Highest  
Grade  
Gold  
and  
Silver  
Plate.

ASK  
YOUR  
DEALER  
FOR AND  
INSIST ON  
HAVING  
"Pairpoint"  
GOODS.

We have in stock  
a large line  
of  
NOVELTIES  
Suitable for Holiday  
Trade.  
Send for our latest  
Illustrated  
Catalogue.



No. 2959, EMBOSSED FLASK.

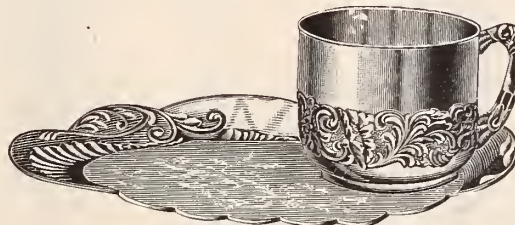

No. 3551. LUNCH SET.

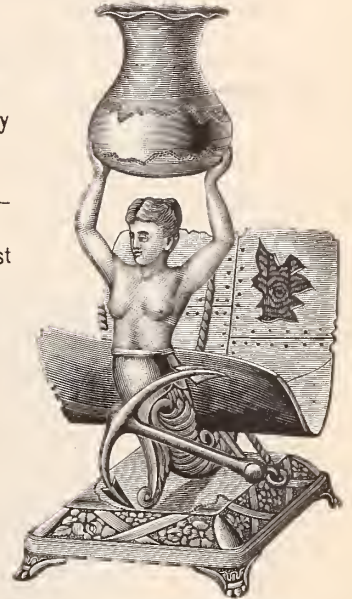

No. 1441. CARD RECEIVER.

SALESROOMS: { NEW YORK, 20 Maiden Lane. CHICAGO, 224 Wabash Avenue. SAN FRANCISCO, 220 Sutter Street.

## JOS. F. CHATELLIER,

860 BROADWAY, NEW YORK,

MANUFACTURER OF GOLD AND SILVER JEWELRY,

### OUR NEW PATENT CLASP,

— FOR —

### Ladies' and Gentlemen's Hose Supporters,

(As is Illustrated.)

*Is the most practically perfect and convenient  
yet offered to the trade.*

We are also makers by secured rights of

THE LINDSAY

### Patent Loop and Button Fastener.

Made only in Sterling Silver and 14k. Gold.

Permission for manufacture of the above illustrated, with terms, can be had upon application.

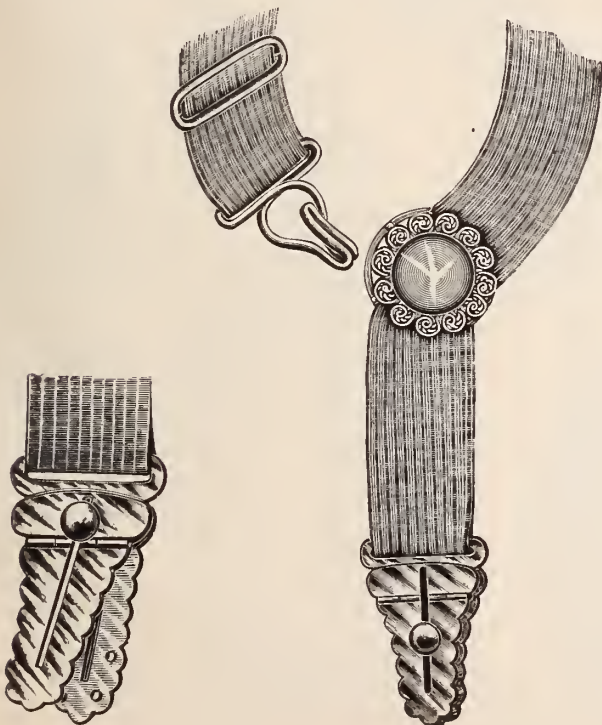



# The "Romanesque." PATENTED.



FLAT WARE was especially designed to supply the demand for a novel and beautiful pattern. The outline and decoration is entirely new. We believe it will please every one desiring the most artistic goods ever produced in Flat Ware.

## MERIDEN BRITANNIA CO., Meriden, Conn.

NEW YORK.

CHICAGO.

SAN FRANCISCO.

HAMILTON, ONT.



Reverse View.



PON BON SPOON.  
Saw Pierced.

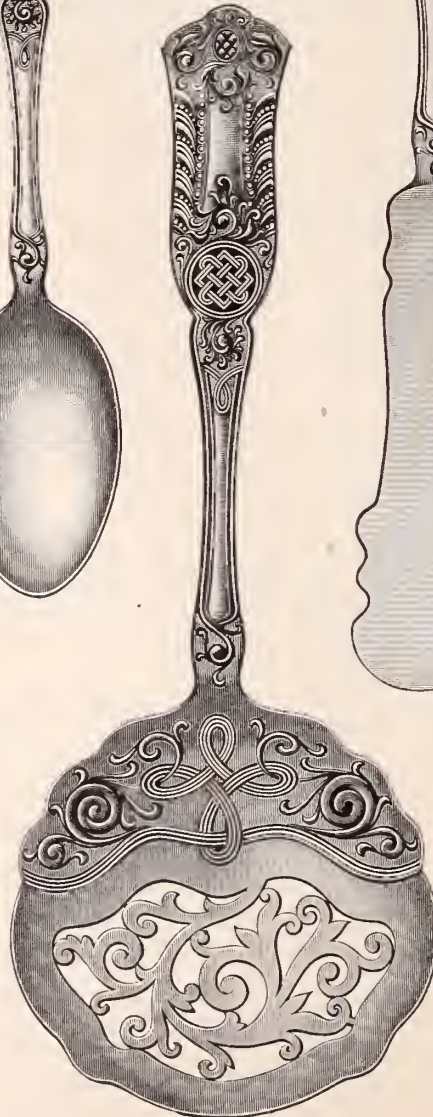



NUT SPOON.  
Saw Pierced.

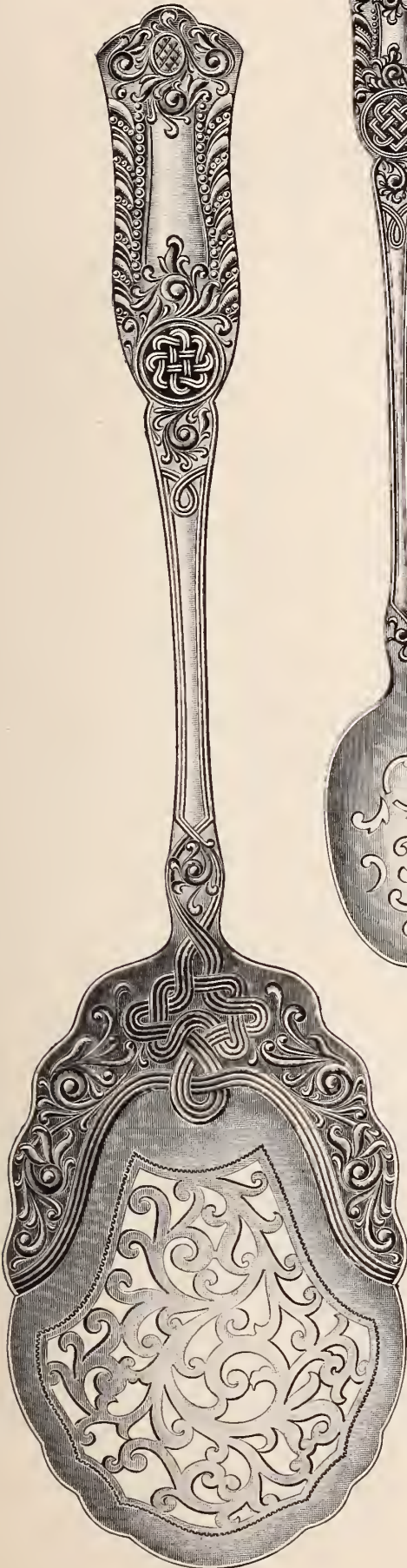

OLIVE SPOON.



CAKE FORK.

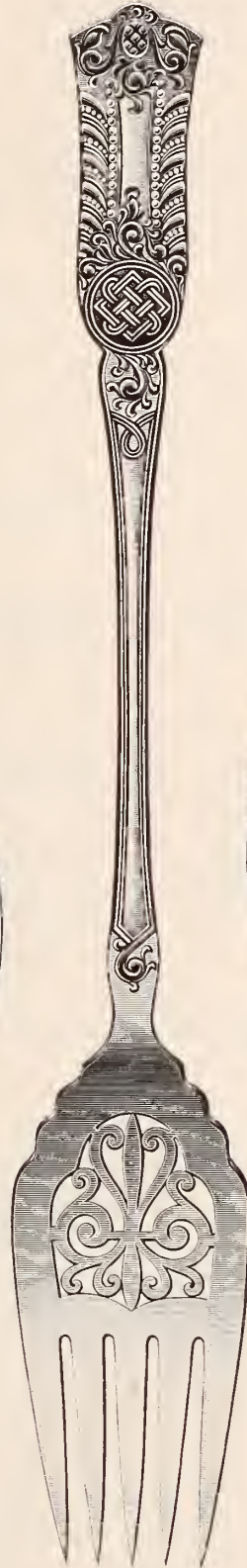

SUGAR SHELL.



PIE KNIFE.  
Saw Pierced.



1847 ROGERS BROS.



MATCH BOXES.

LETTER OPENERS.

BUTTON HOOKS.

SILK WINDERS.

NAIL FILES.



STAMP BOXES.

CUTICLE KNIVES

CIGARETTE CASES.

POCKET KNIVES

POCKET CORKSCREWS.

SYLVESTER S. BATTIN, Jr.

JOHN D. BATTIN.

# Battin & Company,

Makers of

## Original Novelties,

IN GOLD and SILVER,

THIRD AVENUE  
AND OGDEN ST.

NEWARK, N. J.



CALENDARS.

CLINICAL THERMOMETER CASES.

RAZOR STROPS.

CIGAR CASES.

EMERY BAGS.



LORNETTES.

KEY RINGS.

CIGAR CUTTERS.

COMB CASES.

WHISK BROOMS.

NAIL FILE CASES.

JEWEL MATCH BOXES, CIGAR CUTTERS, KNIVES, ETC.



# HAYDEN W. WHEELER & CO., DIAMOND IMPORTERS.

MANUFACTURERS OF

## DIAMOND JEWELRY,

No. 2 MAIDEN LANE. NEW YORK.

50 HOLBORN VIADUCT  
LONDON.

We sell to the legitimate  
Jewelry and Stationery Trade only.



### CHOICE PAPERS

MAKERS OF

### FINE STATIONERY

For Correspondence, Wedding and Business Use, Handsomely  
boxed, specially suited to the Jewelry Trade.

18 MURRAY STREET,

NEW YORK.

## A Plain Business Proposition.

Our papers are so put up as  
to particularly meet the require-  
ments of the Jewelry Trade.



THEY ARE

"NEATLY BOXED,"

THEY ARE

"CHOICE,"

THEY ARE

"COMPACT,"



and hence require no large  
space for display. A good  
salesman can sell writing paper  
as easily as watches or rings.  
There is a good profit and a  
quick sale. No dead stock. The  
outlay is small and the result  
sure. Try it.





Crescent Street, Nickel



Appleton, Tracy & Co., Nickel



Appleton, Tracy & Co., Gilt.



P. S. Bartlett, Nickel, Adjusted.



P. S. Bartlett, Gilt, Adjusted.



P. S. Bartlett, Nickel, Unadjusted.

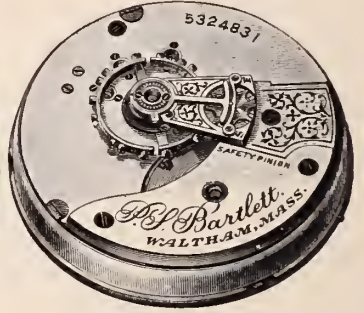

P. S. Bartlett, Gilt, Unadjusted.

# WALTHAM 18 Size.



No. 35, Nickel.



No. 25, Nickel.



No. 15, Nickel, Adjusted.

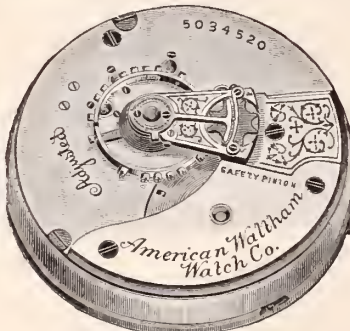

No. 15, Gilt, Adjusted.



No. 15, Nickel, Unadjusted.



No. 15, Gilt, Unadjusted.



No. 3, Nickel.

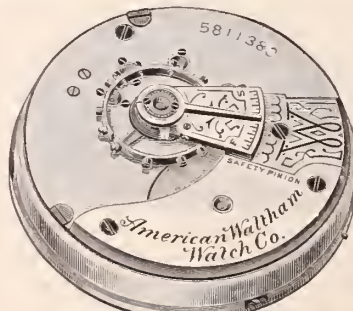

No. 3 Gilt.

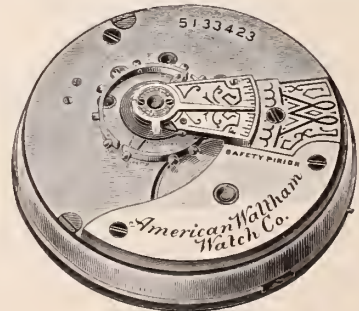

No. 1.



Tortoise Shell

... WITH ...

Sterling Silver

Deposit.

Extensive Lines

... OF ...

Hair Ornaments,  
Lorgnettes

... AND ...

Other  
Novelties.

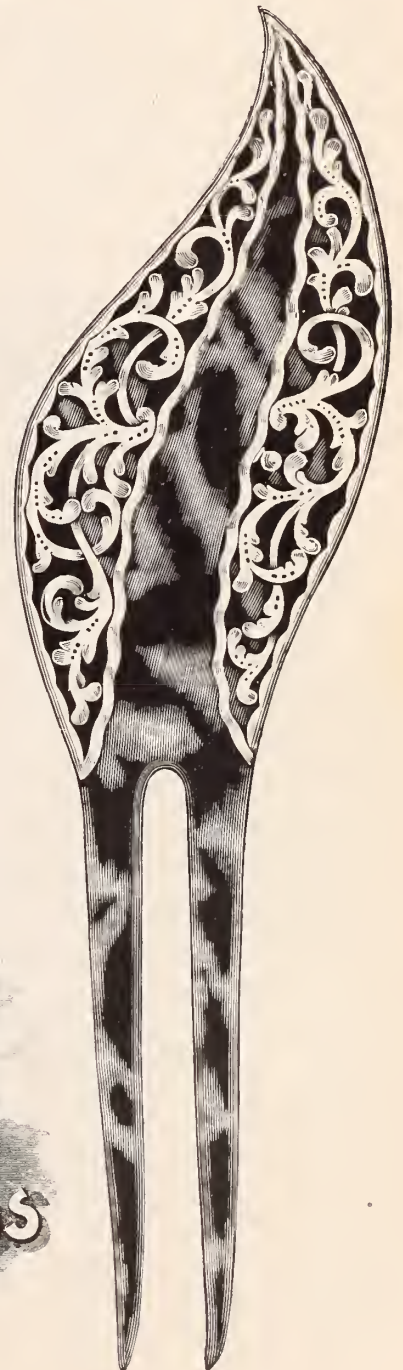

HIGHEST AWARD, WORLD'S FAIR,  
CHICAGO.

Rice & Hochster,

TRADE MARK

Manufacturers of

TORTOISE

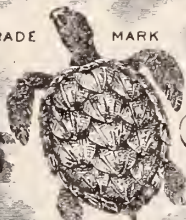

SHELL  
GOODS

483 & 485 Broadway,

New York.





## CHARLES L. TIFFANY AND THE HOUSE OF TIFFANY & CO.

BY GEORGE FREDERICK HEYDT.

CHARLES LEWIS TIFFANY, founder of the house of Tiffany & Co., is a descendant, in the sixth generation, of Squire Humphrey Tiffany, of England. His great-great-grandfather, great-grandfather, and grandfather were natives of Massachusetts. Comfort Tiffany the father of Charles L. Tiffany, was born in Attleboro, Mass., and after marrying Chloe Draper, daughter of Isaac Draper of that town, he removed to Danielsonville, Conn., where he embarked in the manufacture of cotton goods.

Comfort Tiffany established his home on the Killingly side of the Quinebaug River, and here on February 15th, 1812, Charles L. Tiffany, the eldest son, was born. The boy was brought up in the town of his birth, and received his primary education in the "little red schoolhouse" at Danielsonville—a typical New England district school—and later spent two years at the Plainfield (Conn.) Academy, about ten miles from his home. This was at that time a noted educational institute, presided over by John Witter, a graduate and tutor of Yale.

While young Tiffany was at the Plainfield Academy, his father, Comfort Tiffany, who had already been engaged in the manufacture of cotton goods in Danielsonville for about twenty years, formed a new company for the same purpose. They bought half of the water privilege of the Quinebaug River, on the Brooklyn side, and began operations under the name of the Brooklyn Manufacturing Co. While building the new mill, Comfort Tiffany opened a little country store, and gave his son Charles, then but fifteen years old, full charge; and in this inconspicuous way Charles L. Tiffany made his *entrée* into the commercial world. He kept the books of the store, and when the business had become firmly established he made frequent trips to New York for supplies.

About a year after the opening of the new mill, Comfort Tiffany established his home over on the Brooklyn side of Danielsonville, and some time later bought out the interests of his other partners in the Brooklyn Manufacturing Co., and operated the plant under the name of C. Tiffany & Son. After the business of the little country store

had developed, and the elder Tiffany had erected a more commodious store for its purposes, the additional help required afforded young Charles L. an opportunity to take up his studies again, and with several short terms at the Brooklyn school he finally finished his education.

The year 1837 was the turning-point in his life. From the little Connecticut village he

ery and fancy goods store. Mr. Tiffany followed early in September of 1837. New York was then in the throes of perhaps the greatest commercial crisis of its history. Many well established concerns were on the verge of ruin. Mr. Tiffany's ambition, however, was not to be daunted by this grave state of affairs. He and his former schoolmate went carefully over the field together, and concluded to unite Mr. Young's limited stock of experience with whatever capital could be advanced by Mr. Tiffany's father, and to open a fancy goods and stationery store. The elder Tiffany being appealed to, he consented to loan the young men a thousand dollars, \$500 to be assumed by each partner.

TIFFANY & YOUNG.

The young men entered into a partnership under the firm-name of Tiffany & Young, and thus was laid the foundation of the present house of Tiffany & Co. The difficulties which they encountered in finding a desirable location which should come within their limited means, in running the chances of success without any knowledge of metropolitan business methods, in starting out in the very face of the worst commercial depression in the history of the country at that time—these and other obstacles, which to most men would have seemed insurmountable, were overcome by this young firm in a manner that augured well for their future success.

A suitable site for their first venture was finally found in an old fashioned double dwelling house at 259 Broadway. Half of the lower part was already occupied by Mme. N.

Scheltema, a fashionable modiste; the other half, with a frontage of fifteen feet, was obtainable at a moderate rental; the only serious objection urged against the premises being that they were too far up town. Marquand & Co., the leading jewelers of those days, were located at 181 Broadway, near Cortlandt St., and within a few blocks of them were clustered all the jewelers and dealers in high-class fancy articles who had any prominence at that time.

It was A. T. Stewart who perhaps unconsciously turned the balance in favor of No.



C. L. Tiffany

ventured out into the maelstrom of metropolitan life. New York was then a city of over 200,000 inhabitants and proportionately as crowded with business enterprises as it is to-day. Young Tiffany's business venture was not an accident—it was born of a deliberate purpose, the result of his conclusion that the future of the cotton industry in Connecticut offered nothing to satisfy his ambition. Hence he determined to seek a wider field of activity.

His neighbor, friend and schoolmate, John B. Young, had gone to New York six months before him, and was employed in a station-



259. Mr. Stewart, already a successful merchant of ten years' standing, had his own store next door to Mme. Scheltema's and belief in the sagacity of the future dry-goods king led the young men to decide

soon became generally known; patronage increased, and new features were added. On the day preceding Christmas of the same year, the sales footed up \$236, and on New Year's Eve the receipts amounted to \$675. New Year's Day, according to old Knickerbocker usage, was then the approved occasion for the interchange of gifts, as Christmas is now.

The following year marked a steady, though uneventful growth; but on the morning of Jan. 1, 1839, the young firm was robbed of nearly all it possessed. The thieves, who carried away almost everything portable of value, had also evidently calculated upon appropriating the largest single week's receipts of the year; but luckily the two partners had taken the precaution to empty the cash drawer and carry the contents home with them. Their loss amounted to nearly \$4,000; but they quickly recovered themselves, and the business continued to prosper to such an extent that early in 1841 it was found necessary to rent the adjoining corner store, No. 260. With the increased space at their

of the members should go abroad in search of novelties for their exclusive trade. This method of Mr. Tiffany's for obtaining choice selections for retailing at first hand was a unique one fifty years ago. Mr. Young was selected to make the trip.

This year of successes also marked the happiest turning-point in Mr. Tiffany's career. On Nov. 30, 1841, he was married to Miss Harriet Olivia Avery Young, sister of his partner, and daughter of Judge Ebenezer Young, of Killingly, Conn. This union brought them six children. Four are living and reside, some in the home of their parents, others in homes of their own, near-by. Charles Lewis, Jr., the first-born, died at the age of four, and Henry Charles, the third child, died at the age of one. Mr. Tiffany's family now consists of his wife, Mrs. Charles L. Tiffany, and children, Annie Olivia (Mrs. Alfred Mitchell), Louis Comfort, Louise Harriet, and Burnett Young Tiffany.

The success of the first journey abroad warranted annual visits to the European markets, and led to the introduction of useful and fancy articles of a higher order of taste, beauty and richness than had ever been seen before in New York. The house had now established for itself a reputation which made it the resort of all who were in search of rich and costly articles of luxury.

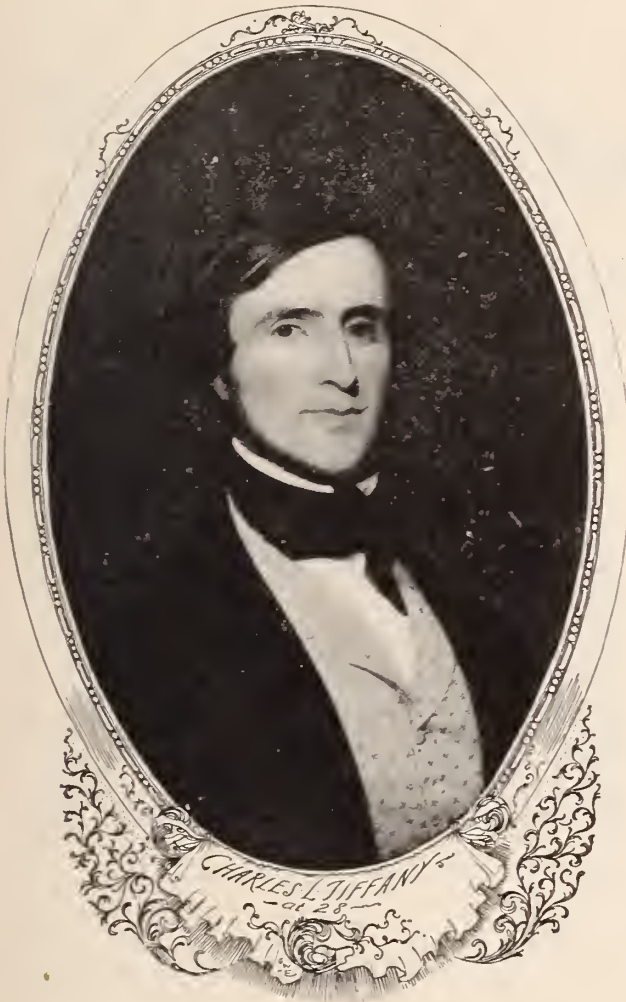

upon this up-town location. This perplexing question disposed of, there followed the problem of how to open business with a stock sufficiently unique and choice to attract custom to a new house.

One of Mr. Tiffany's most noted traits, and one that has distinguished the house in its entire career, is an instinctive avoidance of beaten paths. He was ever devising original methods and seeking unique objects. The store was stocked with salable merchandise. Choice and novel objects in bric-à-brac; Chinese goods, then very popular; Japanese *papier mâché* and terra-cotta wares; umbrellas, walking sticks, desks, dressing cases, cabinets, fans, fine stationery, pottery, fancy articles, and curiosities of every description—these things soon became marked features of the store of Tiffany & Young.

The little store was opened to the public on the morning of September 18, 1837. The total sales for the first three days amounted to only \$4.93; with this they opened their first cash book. The next day \$2 77 was added. But the high character of the stock

disposal, the scope of the business was rapidly enlarged. Bohemian glassware, French and Dresden porcelain, cutlery, clocks and fancy Parisian jewelry were added in the order named.

TIFFANY, YOUNG & ELLIS.

The year 1841 was in more respects than one a memorable one in the history of the young firm. The first important step during the Spring of the year was the admittance of another partner, J. L. Ellis, the firm name becoming Tiffany, Young & Ellis.

The business had now grown to such proportions that the disadvantages of importing stock without a thorough personal knowledge of what the European markets afforded were daily growing more evident. After the addition to the firm, it was decided that one



Shortly the cheap grades of jewelry from France, Hanau and Frankfort, Germany, gave way to a better quality of English jew-



eltry, and this in turn was followed by Italian or Roman jewelry. During this time the mosaic work from Florence and Rome, and the finer jewelry from Paris, enjoyed a period of popular favor running over many

2,285,700 francs (about \$500,000), a larger amount than the total purchases of the nine next largest buyers.

In 1850 Gideon F. T. Reed, formerly of Lincoln, Reed & Co., the leading jewelers

Tiffany & Co. introduced the English standard of sterling silver— $\frac{925}{1000}$  fine. Their example was immediately followed by all the other leading silversmiths of that period, and the standard which Great Britain found necessary to protect with a "hall mark," soon became established in this country upon the reputation of an individual firm. What the house has since accomplished in developing American art in metal work is a matter of history. The improvement in the manufacture of silverware, both in form and decoration, had by this time (1851) become recognized, and with the recognition came rapidly increasing demands for special presentation pieces and household articles. The productions of John C. Moore, who made silverware for Marquand & Co., and also for their successors, Ball, Tompkins & Black, were then attracting considerable attention for their solidity and artistic conception. Upon the retirement of the elder Mr. Moore, he was succeeded by his son, the late Edward C. Moore, who had learned the trade in his father's factory. The skill he had acquired under the tuition of his father, with the resources of Tiffany & Co. and their rapidly growing business, developed the little shop with its handful of employes into an industry of extraordinary proportions, covering to-day almost an entire block in Prince St., and giving employment to a force of about 500 men.

TIFFANY & CO.

The year 1853 marked another important change in the composition of the firm. On May 1st, J. B. Young and J. L. Ellis retired, and with the admission of new partners the business was from that day continued under the present firm name of Tiffany & Co. The change resulted in materially broadening the scope of the business, and



years. Gradually, however, American jewelry encroached upon the field to such a degree that when in 1848 the firm began the manufacture of gold jewelry, it quickly became one of the most important branches of their business.

Before the close of the first 10 years the continued increase necessitated another removal, which took place in 1847. A much larger and more modern store was secured at 271 Broadway, corner of Chambers St., and the business rapidly expanded in every direction. Diamond jewelry, watches, clocks, silverware and bronzes became the leading features of a stock which had now grown so complete in articles of luxury that the house issued an annual catalogue for the convenience of their patrons.

The political disturbances of 1848 in Paris afforded many opportunities for shrewd investments. In the panic that followed, diamonds declined about 50 per cent. Mr. Tiffany and his partner, J. B. Young, were quick to grasp the situation and immediately decided to invest all the available resources of the firm in these precious gems. This first large purchase of gems was followed by many others. Notable among these were the investments in historic gems, of which Tiffany & Co. have probably been among the largest purchasers in the world. Among the most famous gems which passed into their possession was the zone of diamonds worn by the ill-starred Marie Antoinette. This zone was bought by the house in Paris about forty years ago. At the great sale of diamonds of the famous Hungarian Prince Esterhazy, some years later, Tiffany & Co.'s purchases amounted to over \$100,000. But the largest investment ever made by them in historic gems was in 1887. At the sale of the crown jewels by the French Government, Tiffany & Co. purchased 24 lots of the stones—over one-third of the entire amount—at a cost of

of Boston, was admitted into partnership. Immediately after, the first branch house was established at 79 Rue Richelieu, Paris, Mr. Reed becoming the resident partner in Paris, where the house was conducted under the firm name of Tiffany, Reed & Co. This branch house proved an invaluable acquisition to the firm, Mr. Reed's residence abroad enabling him to take advantage of all the fluctuations in the European markets. Like the New York house, the Paris branch developed rapidly. From the little office in Rue Richelieu it removed to 57 Rue du Cardinal Fesch, afterward named Rue de Châteaudun. At the present time it occupies very spacious quarters at Avenue de

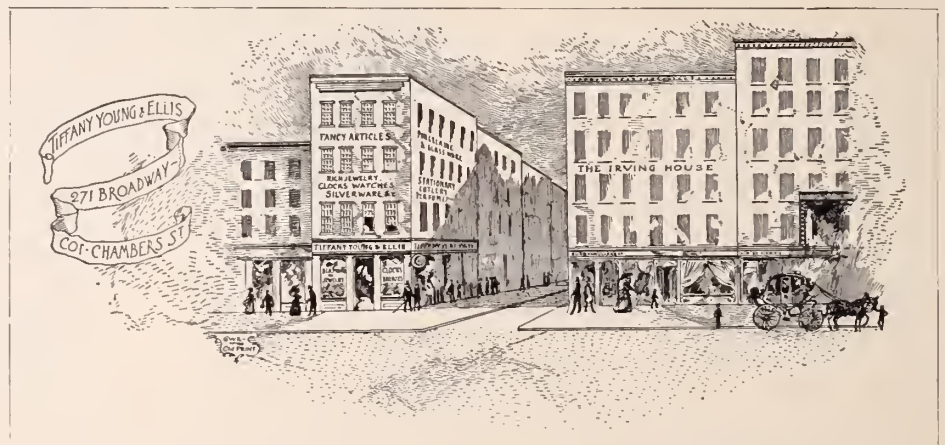

l'Opéra 36 bis. Since the retirement of the late Mr. Reed the foreign branch has been continued under the name of Tiffany & Co.

One of the first innovations made by Tiffany & Co. was that of using the highest practical grade of silver in all of their productions. Up to this time, old Spanish and Mexican coins contributed largely to the supply of metal used; but in these coins there was no uniformity of standard.

the continued increase of the business made another removal necessary in 1854. A new building was erected for their accommodation at 550 Broadway. This location was then considered so far above the business territory of Broadway, that many questioned the wisdom of the change.

The firm took possession of their new quarters on May 1, 1854, and before long the former critics of Mr. Tiffany com-



mended him for his keen foresight The firm remained upon this site for sixteen years, the most eventful of their existence, marked by an immense growth in their

The advertisement from *Frank Leslie's Weekly* of Sept. 11, 1858, may be of interest.

SEPT. 11, 1858.]

FRANK LESLIE'S ILLUS

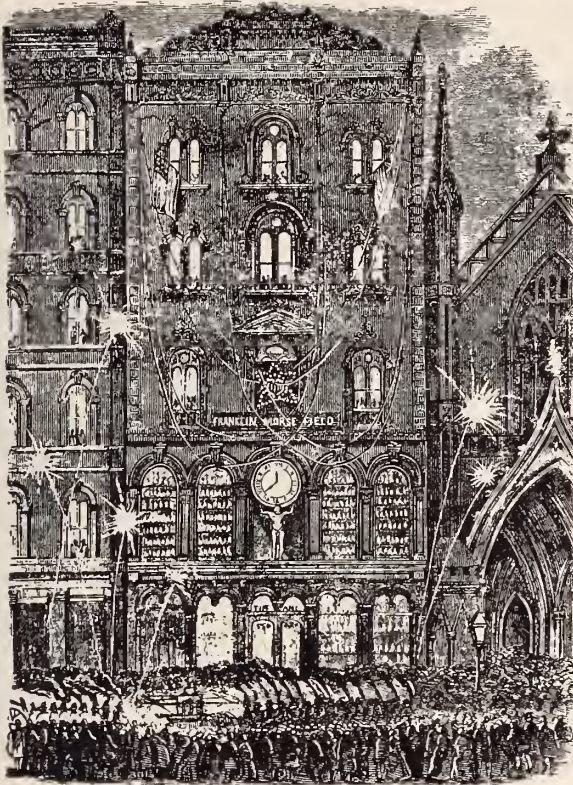

TIFFANY & CO.'S JEWELLERY STORE. 550 BROADWAY, NEW YORK, AS IT APPEARED IN THE ILLUMINATION DURING THE TELEGRAPHIC JUBILEE, SEPTEMBER 1, 1858.

Between the period of the first Atlantic Cable Jubilee in 1858 and the celebration in 1866 of its final success, came the Civil War. Foreseeing a prolonged struggle, Mr. Tiffany promptly made arrangement to devote the capital and facilities of the house to the support of the Government. The elegant show rooms were transformed into a depot for military supplies. Orders for all manner of supplies came in from all over the country—French rifles, ambulances and army shoes, cavalry, army and navy swords and equipments of every kind. Twenty thousand badges were made for the State of Ohio alone, while non-commissioned officers' swords, caps, rifles, army shoes, medals, and corps badges were manufactured and shipped by thousands.

Soon after the Atlantic Cable Jubilee in 1866,

Tiffany

business, and by many historic incidents. In 1861 they added the adjoining building, 552 Broadway, which afforded facilities for meeting the pressure of business incidental to the war, and otherwise enlarging their field of activity. Upon completion of the first great Atlantic cable in 1858, Mr. Tiffany made a clever stroke by purchasing the remaining cable, many miles in all, and cutting it up into souvenirs of the event, making paper weights, cane, umbrella, and whip handles, bracelets, seals and other watch charms, festoons and coils for ornamenting parlors and offices. When the

& Co. again became conspicuous—this time at the Paris Exposition of 1867. They wisely made no attempt to rival the productions of old established houses abroad, or the elaborate masterpieces of European art, but confined themselves almost exclusively to a display of the plainer patterns of domestic plates. The grace and beauty of these designs, together with their delicacy of workmanship and solidity of construction,

called forth the encomiums of the European press, and resulted in the house receiving the first award ever offered to a foreigner. In commenting upon the above, the London *Spectator* said: "We confess we were surprised and ashamed to find at the Paris

The reputation established by Tiffany & Co. during the war for promptly executing great orders, as well as the laurels won at the Paris Exposition for the superiority of their productions, gave the firm an impetus which placed them in the front rank of the world's jewelers. Their store, already one of the largest of its kind, was once more inadequate for their business. The firm was incorporated as a manufacturing company under the laws of the State of New York in 1868, with Mr. Tiffany as president and treasurer; Gideon F. T. Reed, vice-president; Charles T. Cook, general superintendent and assistant treasurer; and Geo. McClure, secretary. Upon Mr. Reed's retirement in 1875 from active participation in the management of the business, Charles T. Cook succeeded him as vice-president.

Mr. Cook's connection with the house of which he is now the vice-president dates back to 1848. Since the incorporation of the business he has shared with Mr. Tiffany the responsibility of its general management. Mr. Cook's work has brought him in touch with most of Tiffany & Co.'s patrons during the last 25 years; and to his executive abilities, and the judgment which he exercised, Mr. Tiffany attributes much of the success that has come to the house.

The incorporation of the house as a manufacturing company was followed by a general expansion of the business, including the manufacture of watches, clocks, etc. The silver works in Prince St. were united to the commercial department and considerably enlarged, and then Edward C. Moore became a director in the company and manager of its manufacturing interest. At

313-350 No. 6 Maiden Lane.

**To Army and Navy Officers.**

TIFFANY & CO., 550 AND 552 BROADWAY, have in store, and are receiving by every steamer, Swords "warranted to cut wrought iron," from Solingen Passants. Cap Ornaments and other Embroideries from Paris. Gold Epaulettes and Navy Laces, etc., from London. Orders by mail promptly filled, and Goods forwarded to all parts of the Loyal States. 313-150

MISCELLANEOUS.

**TIFFANY & CO.,**  
No. 550 BROADWAY, NEW YORK,  
announce that they have secured the entire balance of the  
**ATLANTIC TELEGRAPH SUBMARINE CABLE,**  
Now on board the  
**U. S. STEAM FRIGATE NIAGARA.**

In order to place it within the reach of all classes, and that every family in the United States may possess a specimen of this wonderful mechanical curiosity, they propose to cut the Cable into pieces of four inches in length, and mount them neatly with brass ferules.

Each piece will be accompanied with a copyrighted facsimile certificate of

**CYRUS W. FIELD, Esq.,**  
that it is cut from the genuine Cable. Twenty miles of it have been actually submerged and hauled up from the bottom of the Ocean. This will be first sold in precisely the condition in which the great Cable now lies in the bed of the Atlantic.

Orders will be received from dealers and others for not less than 100 pieces at a time, at \$25 per hundred. Retail price, 50 cents each.

Each order must be accompanied by the money, in funds current in New York, as it will not be possible to open accounts. A register will be kept of the orders as they are received, which will be filed in turn without favor or partiality.

A large portion of the specimens will be ready, it is expected, for delivery within a week.

New York, August 21st, 1858. 144-146

**GREEN'S LADIES' AND CHILDREN'S**

articles were put on sale, policemen were required to maintain order among the crowds who were eager to buy the souvenirs.

New York firm, Tiffany & Co., had beaten the Old Country and the Old World in domestic silver plate."

about the same time a branch house was established in London, England, with an office at 29 Argyll St., but soon more spa-



cious quarters were needed, and a removal was made to 5 Argyll Place. At present the London house occupies a handsome store at 221 and 221A Regent St.

The establishment of the London branch was followed by the construction of a large plant for the manufacture of watches in Geneva. Arrangements were made to unite the best European skill with the latest mechanical improvements and labor-saving methods that American ingenuity could devise. It was a unique experiment, and to it the house directed the lavish resources and energies at its command. The first Geneva office was established in 1868 at 7 Rue Le-verrier, and a salesroom for watches, jewelry and diamonds was opened a few years later at 10 Grand Quai, pending the completion of their watch factory. This was erected at the Place Cornavin—where it still stands—in 1872, but after a thorough trial, the conditions surrounding European labor were found to be wholly inapplicable to American methods. Better results were obtainable by turning both patterns and patents over to a watch company to operate and manufacture the superior timepieces required by the firm.

As an immediate result of the incorporation, steps were taken to provide more adequate quarters for the business, which had entirely outgrown the facilities of 550 and 552 Broadway. Upon the corner of Union Square and 15th St., the present site of Tiffany & Co.'s establishment, stood Dr. Cheever's ivy-covered "Church of the Puritans." The church had just been vacated, and the property, with a frontage of 78 feet on Broadway and 140 feet on 15th St., was offered to Tiffany & Co. The picturesque Square and other advantages led to a quick decision, although the conditions of sale necessitated the purchase of the church with all its fittings, including organ pews, etc.

five-story structure was one of the first strictly fire-proof buildings erected in the city.

The building was completed late in the Fall of 1870, and on Nov. 10th formal possession was taken. With the removal to Union Square, many new departments were added. While at 550-552 Broadway, Tiffany & Co. had gratuitously stored many valuables for their patrons; they now portioned off half of the entire basement for a storage department with burglar-proof vaults.

The first floor was divided up between the silver, diamond, jewelry, watch, fancy goods, leather goods, umbrella, stationery, plated ware, watch repairing and jewelry and silverware repairing departments, with offices in the rear; while the entire second floor, with the exception of a portion in the rear reserved for the executive and bookkeepers' offices, was devoted to the display of art works in bronzes, statuary, bric-à-brac, clocks, mantel sets, lamps, curios, reproductions of ancient armor and ornamental objects for home decoration.



TIFFANY & CO.,  
UNION SQUARE, NEW YORK.



TIFFANY & CO.'S NEW PLATED WARE WORKS.  
FOREST HILL, NEWARK, N. J.

Plans were immediately drawn for an absolutely fire-proof building; and the present

limited stock at the old store of a few choice pieces of fancy porcelain and glassware was now enlarged to a special department for high class pottery and cut glass. This collection occupies the third floor, and here everything in that line required for the proper furnishing of a household could be obtained, while special attention was given to securing choice specimens of antique glass and pottery and examples of the most beautiful of modern products to be found in

the European markets. The two upper floors afforded ample facilities for organ-

izing new shops and enlarging the old ones. These are located at present as follows: Third floor extension, watch and fan shops; fourth floor, engraving and art department, stationery, printing and stamping; silver polishing and clock shops; fifth floor, jewelry, diamond cutting and polishing, case and leather work shops.

Since the removal to Union Square, the manufacture of electro silver plated ware has been added to the business. From a small shop in Newark, N. J., this branch of their manufactures has so expanded that a year ago a seven acre plot was purchased at Forest Hill, a suburb of Newark, N. J., and the erection of a large plant begun, which has recently been completed; the new works at present occupy 45,000 square feet, and are so designed that additional wings and stories can be added to meet further requirements.

Reviewing the results of the last quarter of a century's activity—from the Paris Exposition of 1867 to 1893—this era of peace and development shows a succession of international victories of great significance to American industries. At the Centennial Exposition in 1876, Tiffany & Co.'s exhibit of the masterpieces of their art in the various departments left them virtually without competitors. In addition to a gold medal,



special recognition and certificates of award were bestowed for the display of jewelry, jeweled watches, silverware, silver inlaid with niello and copper, and wedding stationery.

The recognition and awards Tiffany & Co. received at the Paris Exposition of 1867 have already been mentioned, and the honors bestowed upon them at the last two Universal Expositions held at Paris in 1878 and 1889 are of too recent date to call for any comment. In 1878 they received the *Grand Prix* for silverware, a gold medal for jewelry, and six medals to co-laborers; while Mr. Tiffany, who attended the Exposition, was made the recipient of distinguished honors. He was created a Chevalier of the National Legion of Honor of France, and from the Emperor of Russia he received the Gold Medal *Premia Digno*—an exceptional tribute. Then followed appointments as Imperial and Royal Jewelers, Gold and Silversmiths to most of the monarchs and dignitaries of Europe.

At the Exposition of 1889 the *Grand Prix* for silverware was again awarded to the house. E. C. Moore, the late manager of the works, was created a Chevalier and decorated with the ribbon of the Legion of Honor. In addition to this, sixteen other medals were awarded to the productions of the house: gold medals respectively for jewelry, precious stones of North America, leather work,

ivory carved and mounted, copper plate engraving and printing; silver and bronze medals respectively for glassware and clocks, and ten medals to co-laborers.



THE TIFFANY PAVILION,  
WORLD'S COLUMBIAN EXPOSITION.

The exhibit made by Tiffany & Co. at the World's Columbian Exposition of 1893 at Chicago, is of too recent occurrence to comment upon at length in this article.

*The Art Journal*, of London, said in reference to the exhibit: "Passing to the exhibit of Messrs. Tiffany & Co., of New York, one finds a display more varied in expression and original in design, more distinctive and individual, than the work of any other firm in the art metal group. And above all we must note the distinctively American characteristics of many of the exhibits here. Judging by the productions exhibited, one may well be in doubt whether our much boasted European pre-eminence in these things is to last much longer, and whether, after all, we shall not in the near future be compelled to regard the firms of New York as at least our equals, if not our superiors, in the production of high class gold and silver work." Tiffany & Co. have received 55 awards at the World's Columbian Exposition; but while these many additional honors are appreciated, they mean but little compared with that calm verdict of public approval so generously given.

The directors of the house of Tiffany & Co. at present are: Charles L. Tiffany, president and treasurer; Charles T. Cook, vice president and assistant treasurer; Paulding Farnham, secretary. The trustees are: Charles L. Tiffany, Charles T. Cook, Louis C. Tiffany, Paulding Farnham, John C. Moore and Alfred Mitchell. The manager of the Paris branch is Charles M. Moore.

## THE COMMERCIAL TRAVELER.

"Homekeeping youths have ever homely wits."

—Shakespeare.

IT is not to be supposed that Shakespeare had in mind the commercial traveler when he penned the above words, but he undoubtedly meant to convey the idea that it was travel that sharpened the wits and made wise the man of the world. If this be true of the man who travels for pleasure, it must apply with far greater force to a commercial traveler, for his occupation brings him in very close touch with mankind; and he is thus afforded a golden opportunity to make a most earnest study of humanity. Of all things, it is most difficult to hide human nature, which, like the hard and rugged flints which flash the shining sparks one from the other as they come in contact, exerts itself in that great struggle of the "survival of the fittest," or, in other words, the pursuit of money; for disguise man's vocation under the name of poet, sculptor, musician or painter, or merchant, mechanic or salesman, it is but a means to this end, bringing out all that is cruel and cunning, or all that is noble and true in the human breast.

The lives of a great majority of the busi-

ness men of all nations are passed in the narrow confines of their offices, which to them, form the bounded world. But the life of the commercial traveler is bounded alone by the blue canopy that envelopes this great globe, peopled with its teeming millions of human beings whose souls are aflame with hopes and ambitions, the realization of which makes this earth a paradise, or the destruction of which turns the sunshine of life into the dark shadows of despair.

It is with these hopes and ambitions that the traveling men are spurred on to achievement, for it is upon their skill and tireless energy that the business men of the country most depend. It is this vast army of nearly 500,000 wide-awake men, spending annually \$175,000,000, who keep turning the fast running wheels of the mills and factories of America whose hum and whirr are the sweet song of industry that tells of happy homes and prosperity.

From the ever open pages of the book of human nature, the commercial traveler learns the greatest of lessons; he learns to

know himself, and thus he is of all men the best fitted to cope with the cunning, the weakness and love of flattery and honor which are inherent in all men to a greater or less extent, and which are the great forces that dominate and rule the world.

His work is never done; all through the hours of the day and long after the weary sun has sought rest behind the red and golden clouds, the commercial traveler works on, ever adding to the wealth of his employer. Far into the shades and shadows of the night he toils on, while the laborer sleeps the sleep "that knits up the raveled sleeve of care," and while all the world is in peace and quiet, the commercial traveler is far from those he holds most dear, and by his enforced absence is barred from the true pleasure and happiness that only linger in the soft and genial glow of the fireside of that place most dear to all the world, his home.

*John L. Shepley*



# REEVES & SILLCOCKS,

19 MAIDEN LANE,  
NEW YORK.

MAKERS OF FINE GOLD JEWELRY AND SILVER NOVELTIES.

Sterling Silver Belts,  
Hair Pins,  
Hat Pins,  
Garters,  
Umbrella Fasteners,  
Tie Fasteners,  
Scabbard Sword Pins,  
Link Buttons,  
Paper Cutters, Etc.  
14k. Hair Pins,  
Scarf Pins,  
Brooches,  
Seal Charms,  
Chain (padlock)  
Bracelets a specialty.



FACTORY, NEWARK, N. J



## Announcement.

*Big reduction  
of former prices.  
We are  
constantly adding  
many new  
ideas to our line  
in  
Silver  
Novelties.*



## LATEST NOVELTIES IN SILVER PLATE.

Awarded Diploma for  
Most Marked Progress.



MELON SPOON.

Award for Durability  
Hitherto Unknown.



SUGAR SIFTER.

5 Awards Covering  
All Points of Excellence  
in Spoon Manufacture.



WALDORF TEA SPOON.  
(INLAID QUALITY.)

SPECIAL REDUCTION MADE ON OUR SPECIAL FANCY PIECES FOR 1894.

# The Holmes & Edwards Silver Co.,

Bridgeport, Conn.

NEW YORK 2 MAIDEN LANE,  
SAN FRANCISCO 120 SUTTER ST.

SALESROOMS: { CHICAGO, 65 WASHINGTON ST.  
ST. LOUIS, 317 N. FOURTH ST.



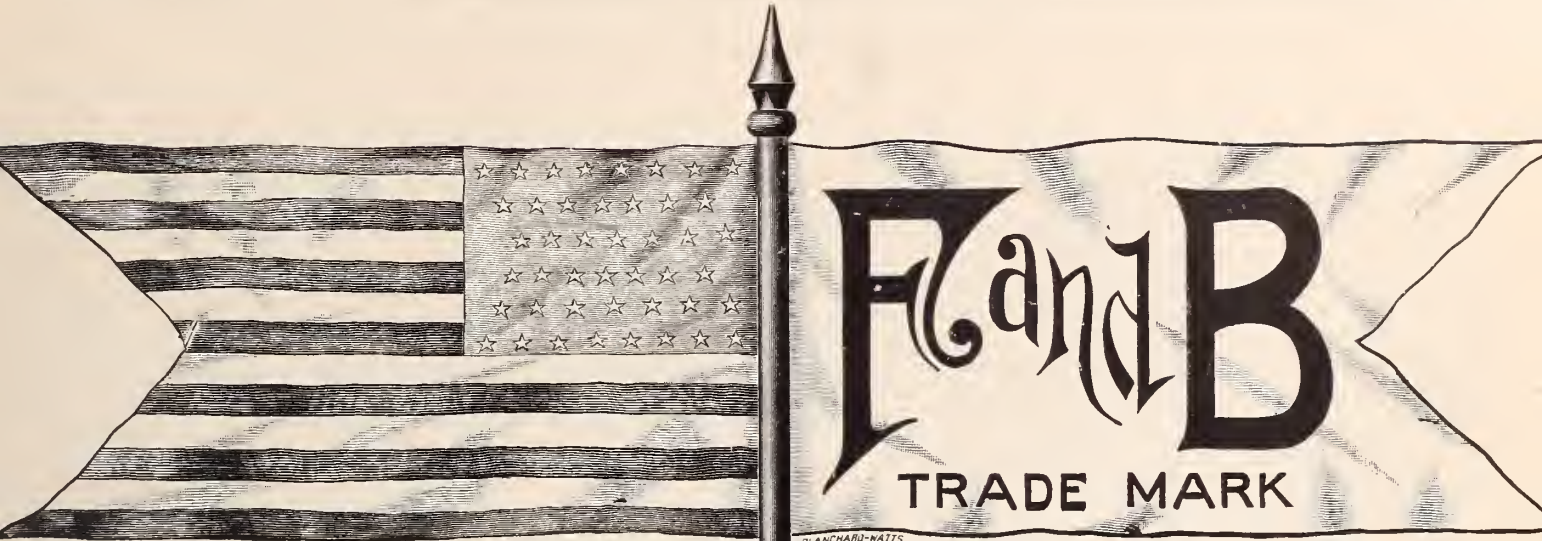

Our American F. & B.  $\frac{1}{10}$  Gold Chains will assay 10 K. 1-10 gold, and are guaranteed for ten years.

Our regular line of Chains is made of heavy gold plate, finely finished, and guaranteed for five years.



**Chains**

Our new line of chains will assay 10 karat 1-10 gold. All gold soldered.  
**American F. & B. 1-10 gold.**

WE RECEIVED  
**4 MEDALS**  
AT THE WORLD'S FAIR.

**Mount Hope Button.**



CLOSED.

**Watch Chains for Gentlemen**

These goods are of fine quality, and guaranteed to give satisfaction. Some recently added have sold far beyond expectation. They are made of heavy rolled plate in all sizes and patterns.

**Watch Chains for Ladies**

Our Victoria and Princess chains are neat and pretty. They are made in all bright, Roman and bright, platinum and bright gold, and have one or two charms.

**Mount Hope Button.**

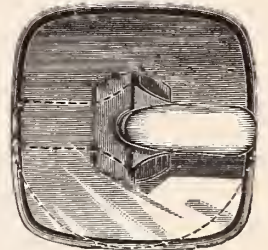

OPEN.

**Charms**

This line is adapted to ladies' or gentlemen's chains, and includes a number of heart charms in Roman, bright and satin finish, with stones and without.

**Hair Chain Mountings**

In solid gold and rolled plate. We are headquarters and make everything desirable in this line.

**Bracelets**

We make a large stock of curb bracelets in five sizes, besides the graduated links, with padlocks and snaps, in chased and plain polished, Roman, rolled silver plate and sterling silver. Also padlocks with keys and a push snap.

**Pins**

Our large line of lace and cuff pins comprise many desirable patterns in gold fronts engraved and trimmed. Also includes baby pins and scarf pins.

**"Mt. Hope" Buttons**

These are superior to any button in the world. They are easy to put in and easy to take out of the cuff.

**Link Buttons**

This line has increased rapidly with us, and is very low in price, embracing all styles in Roman, chased, engraved and plain, with and without stones, and some in enamel.

**Crosses**

We make four sizes of gold filled in plain, engraved and set with stones, and suitable for our neck chains.

**Sterling Silver and Solid Gold Sword Scarf Pins**

**Glove Buttoners**

We make the Interlocking and one with a twist handle in gold rolled plate and silver rolled plate.

**Earrings**

This line includes many pretty patterns in gold fronts engraved, some with pretty trimmings and a small line of hoop drops.

**Neck Chains**

We make a variety of neck-chains in bright and Roman, with snaps.

**Sterling Silver Bracelets and Padlocks**

**Gold Locket Set with Diamonds**

These lockets are made of 10 karat gold throughout and set with brilliant diamonds. They cannot be surpassed in finish or cheapness of price.

**Gold Locket Engraved**

These lockets are also made of 10 karat gold throughout, with beautiful designs engraved thereon and the price is so low that they cannot fail to be in great demand.

**Gold Front Locket**

This line is very extensive. Many patterns are plain polished, others nicely engraved, with and without stones.

**Rolled-Plate Locket**

This line is almost endless, and consists of nearly every conceivable shape, size and style. Some are set with imitation diamonds, rubies and sapphires.

We have put upon the market a line of Gentlemen's Chains and Ladies' Chain Bracelets made of 1-10 gold stock. Every joint is soldered with gold, and every Chain or Bracelet will assay more than 1-10 gold. They are our AMERICAN F. & B. 1-10 GOLD goods, and are so stamped. Bar, Chain and Swivel are stamped 1-10 gold.

**FOSTER & BAILEY, Providence, R. I.**



## THE AMERICAN WATCH AS A PRODUCT OF NINETEENTH CENTURY GENIUS.

BY EXCELSIOR.

AMONG the products which exemplify the distinctive characteristics of the nineteenth century and mark the changes which it has witnessed, perhaps none show the difference between our day and the past more plainly than the American watch. Good watches were made before this century, but even the cheapest were expensive, and only the well-to-do could possess them. To-day far better watches are within the means of everybody and are carried even by the boys in knickerbockers. This is not the result of mere increase of manufacture and consequent reduction in price, but of a radical change in the entire industrial system and the application of new business principles and methods in their production.

## THE OLD STYLE.

At the beginning of the century watches were made piecemeal, from the raw material—the gold, silver, brass and steel, forged and cast. Every part was separately rolled and brought into approximate shape, worked down to proper form, fitted, tempered and polished, and the different parts fitted to each other. Wheels and pinions, plates, springs, balances and escapements, dials, hands and the many miscellaneous pieces required to make a complete movement—all of these the skilled artisan could make with his own hands. There were watchmakers in those days.

With tireless industry and care, consummate skill and almost infinite patience, the workman would toil day after day, and week after week, to make a single watch. Had some apparition revealed to him that the time was at hand when watches would be made by automatic machines, and that a far better movement and more perfect timekeeper than his could be made and sold for a single dollar, he would have laid down his tools in despair and prayed: "Good Spirit, let me die!" That is now possible, and the class to which he belongs is already well nigh extinct in this country.

But when he had completed his movement, another long and tedious task was before him, the making of a case for it. Not only the diameter and thickness of the movement must be provided for, but the width and depth of every shoulder, every screw head and piece projecting beyond its circular outline must have its corresponding recess in the case, the openings for the winding and setting posts must be accurately located, the lifting and locking springs must have room for play, and must be so placed that when

pressed inward they would not interfere with any working part of the movement, while a dozen other points must be attended to,—enough to render case making a difficult trade in itself.

All this has been changed. The present century sees a complete revolution in the method of watchmaking, in this country at least. Not only are the American companies far in advance of all rivals in their improved system of manufacture, but the system itself is of American evolution.



A. L. DENNISON

"THE FATHER OF AMERICAN WATCHMAKING."

## THE NEW STYLE.

The first great change was the substitution of machinery for manual labor, and the production of great numbers of pieces exactly alike. As the machines were constructed to produce those forms which study and practice showed to be best, the result was that the finished pieces were not only very cheap, but as perfect as knowledge and skill could design. Then came the production of complete movements exactly alike, having the same size, shape and outline throughout, whereby it became possible to also manufacture cases by machinery, in vast numbers, and to have any of the movements fit into any of the cases, making complete watches. Then, for the first time, the watch became a true article of manufacture, as distinguished

from a hand made and hand fitted product. MECHANICAL AND COMMERCIAL ADVANTAGES.

The advantage of this state of affairs to the manufacturer was that skilled workmen could be quickly trained, the product was practically perfect, the output of each workman was very large, the requisite parts could be assembled into a complete movement with little or no special fitting, any sudden demand could be easily met by running the proper machines to their full capacity, and the cost was very small compared with that for the same quality under the old systems.

Its advantages to the case makers were even more apparent. As they no longer had to fit each movement, they could make great numbers of cases for the same "block," (representing the shape of the movement which was to go into them), and were justified in getting the most complicated and costly machinery for rolling, stamping, punching, etc., and the cost for each case was reduced almost to the expense for the gold, silver and other material used, leading to greatly increased sales.

Then came another improvement: the filled cases now so common and popular. In former times, when a customer's head became so large that a silver case was not good enough for him, but he could not afford one of fine gold, the workman would accommodat-ingly reduce the quality of the gold to obtain the requisite cheapness. Instead of 18 karat, he would use 12 karat, 10 karat, 8 karat, and even 6 karat gold, and the wearer would have to keep a supply of brick dust and a rag handy, to scour up his case when it turned black or green, for those old fellows

did not like to be accused of carrying brass or copper watches any more than our *fin-de-siècle* exquisites do.

The modern American case makers improved on these early methods by putting all the gold on the outside, where it would do the most good. By using a central plate of composition metal for body and stiffness, with plates of good gold brazed on each side of it to give a fine surface, they made cases having the appearance and serviceability of solid gold, which would last for a long time before the gold was worn through. In fact, some of our nineteenth century manufacturers have attained such perfection in this respect that they will guarantee their cases to wear for 251 years, lacking 1. The centuries yet to come will hardly be able to



**Hunting only.**

RAILWAY Nickel, 15 *extra* fine Ruby Jewels, in solid gold settings, 14 *Carat*, gold patent regulator, compensation balance adjusted to *heat, cold, isochronism* and *positions*. Particularly desirable and specially recommended to meet the requirements of the *Railway Service*.

The Company list them at \$25.00

**Our Price \$13.50**

**NET.**

**THIS !!**  
**BEYOND QUESTION**  
 IS THE  
**GREATEST BARGAIN**

**WE EVER OFFERED.**

**THEY PASS RAILROAD EXAMINATION.**

*Yours Truly,*  
*J. S. Rosefield.*

**34 MAIDEN LANE NEW YORK.**



**WE ARE**  
**ALWAYS IN THE LEAD**

OWING to the hard times we have concluded to reduce prices in proportion and put the well known ACME LATHE within reach of everybody. The following is a *Genuine Bargain* and excels *anything and everything* ever offered before. Note the prices of our competitors and be *convinced*.

If not satisfactory after a 5 days' trial, it can be returned to us and money will be refunded. All orders are filled the same day as received. We carry Genuine Material only; send only such goods as ordered, and never substitute.

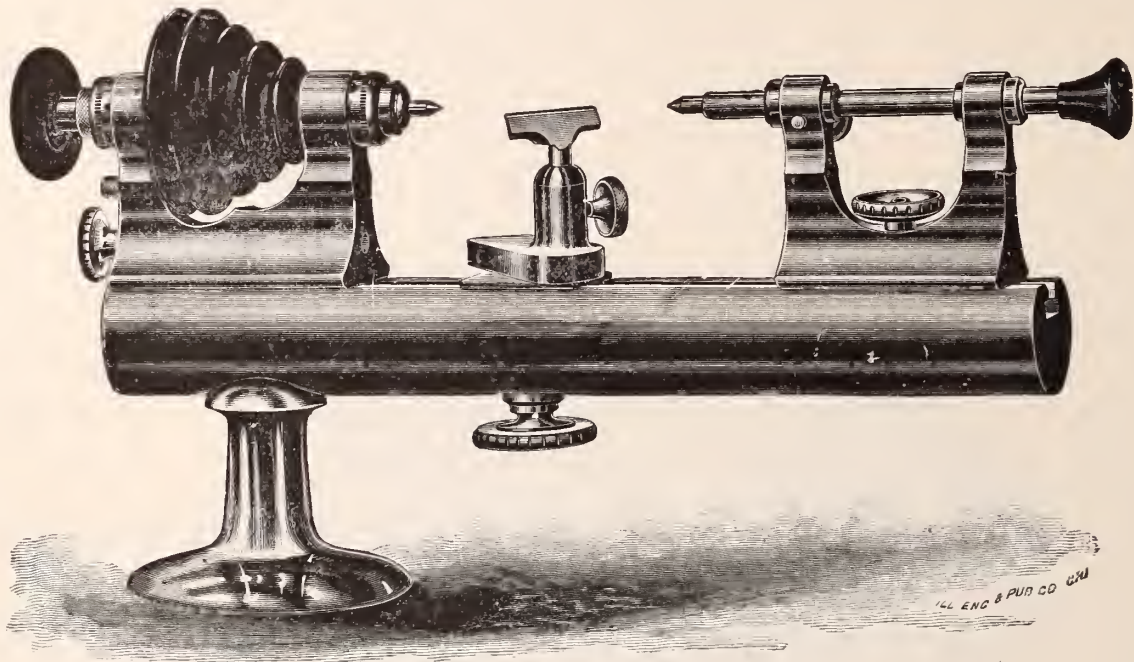

THE prices given below being so remarkably low, we must request you to enclose the money with order. Every Watchmaker should have a Lathe.

**THE GENUINE ACME LATHE.**

With the following combination: 1 Lathe, No. 1x2 hard, 10 Wire Chucks, 3 Wheel Chucks, 1 Screw Chuck, 1 Brass Cement Chuck (1 inch), 1 Brass Cement Chuck (1/2 inch), 6 Brass Cement Chucks (1/4 inch), 2 Steel Tapers, 9 Feet Belting and 1 Oak Chuck Box. The ACME LATHE is the same size as the 1x2 Moseley, with which all parts will interchange. *It is guaranteed to be hard and true.*

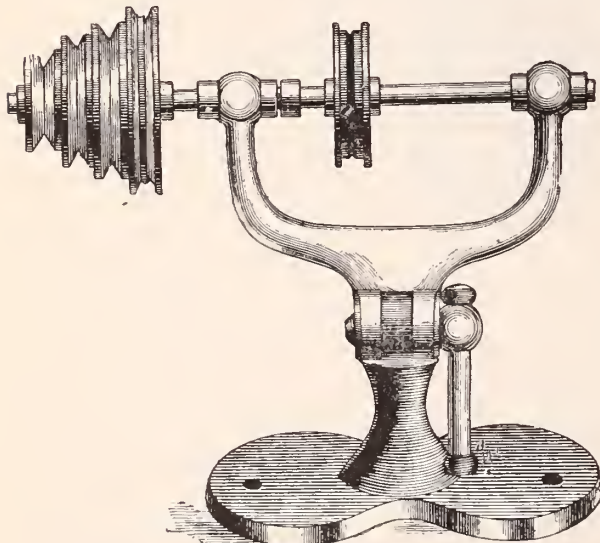

A well made, nicely Nickel Plated Countershaft, is adjustable, has Rubber Pulley and Babbitt Metal Bearings.

This Entire Outfit, consisting of one **Genuine Acme Lathe** with Chucks as above, one **Acme Foot Wheel**, one **Nickel Plated Adjustable Countershaft**, all for

**\$25.00**

NET CASH.

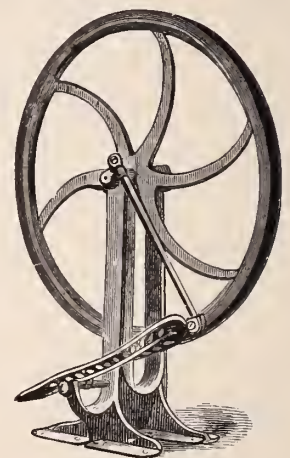

The **Acme Heel and Toe Foot Wheel**, easy running and grooved for belt.

**Glickauf & Newhouse,**

84 & 86 STATE STREET, CHICAGO, ILLS.



go much beyond this achievement.

The mechanical system of watchmaking was equally advantageous to the retail dealer. After a little experience with the different grades of watches, he always knew just what he was buying, without examination or selection. With a very small stock, say, four movements and four cases, all different in style or quality but of the same caliber, he could make ten combinations of movement and case, and could virtually offer the customer a choice from ten different watches, instead of from only four, as by the old system. The benefit was equally important with larger stocks.

Customers are hardly ever competent to select a movement. They can only tell



EDWARD HOWARD.

FOUNDER OF E. HOWARD WATCH CLOCK CO.

about what kind of service they will expect from it. For one, anything which does not stop, and which will not vary more than five minutes in a day, will answer all purposes; while for another it must be as nearly a perfect timekeeper as can be obtained. Between these extremes are all the grades required to suit any customer. Knowing his wants, the dealer can at once pick out the proper movement for him. But in the selection of a case, the customer chooses for himself. He may want one of gold, or silver, or filled, light, or heavy, engraved, ornamented, or jeweled, open-faced or hunting. Whatever his preferences may be, the selected case and movement are put together in a moment, and the watch is ready for him. There is no long delay, no excuse for waiting, no chance to change his mind; he gets the watch he wants, and pays for it while his satisfaction is still warm. With the old style of watches, it is almost impossible to suit a fastidious customer. If the case pleases him, the movement does not; if he likes the movement, he does not like the case that goes with it. There is always something wrong somewhere. But by the American plan, it is an easy matter to suit him all around. To the dealer who under-

stands human nature and the requirements of successful business, this feature of the American watch would alone make it preferable to all others which do not possess the same advantages.

For the watch repairer this system facilitates his work, since it is easy for him to obtain new pieces exactly replacing any part worn or injured and restore the watch to perfect condition. He can with equal ease fit a new movement, better or different, in a cherished case, or replace a damaged or worn out case by a new one for a valuable movement.

Among the other mechanical improvements to be found in the American watch are the reversible center pinion, to prevent damage when the mainspring breaks; durable stem winding and setting mechanism; strong and easily adjustable escapements; long and thin mainsprings, enabling the stop works to be so arranged as to obtain a nearly uniform motive force, which, in connection with a detached escapement and isochronal hairspring, secures all the advantages of the former chain and fusee arrangement, while being much simpler, cheaper and safer; hardened and tempered hairsprings, instead of the soft and unreliable spirals formerly used; non-magnetic balances, which prevent the watch from being disturbed or stopped by the electrical and magnetic devices now encountered everywhere; and numerous others, not the least of which is the solid, substantial and serviceable construction of the entire movement.

#### ADVANTAGES IN TIMEKEEPING.

As regards timekeeping the improvements are remarkable. Aside from those already noted, which enhance the efficiency of the movement in every part, is a series of improvements worthy of special notice, which were primarily intended to perfect the higher grades of movements and at the same time reduce their cost and bring them within the means of ordinary wearers, but which incidentally also improve the quality of the lower grades.

Isochronal hairsprings and compensated balances were known before this century, but the cost of an adjusted movement was enormous for those days, and few could own them. As late as 1850, many of our watchmakers and jewelers had never seen one. They would smile quizzically when "adjusted" movements were mentioned, and remarked that they were adjusted to extract a big price from the purchaser. Thousands of people now carry them, and think so little of it that they hardly remember whether they bought them as adjusted watches or not, showing that there was nothing particularly strange about the price paid, or they would recollect what it was for. Surprising as it may appear, the modern American system enables the manufacturer to produce adjusted movements which have never been adjusted, and he can therefore sell adjusted watches without charging for the costly operation of adjusting.

This seeming paradox is easily explained. The manufacturer takes a perfectly adjusted balance for a model, and makes others exactly like it in every respect, on the supposition that they will perform like the model without requiring to be adjusted as that was. In other words he makes them already adjusted. In practice, it is not so easy and simple as it might appear from the foregoing statement. The process begins at the very beginning, and requires, as its foundation, that the entire movement be carefully calculated and designed so that its construction shall be permanent. For if any material change in its plan should afterward be made, the size and mass of the balance must necessarily be changed also, and the hairspring



DANIEL F. APPLETON.

ROBBINS & APPLETON.

must be altered to suit the balance. This would necessitate new models for both, and a new set of means for their manufacture.

But supposing that the train is as perfect as possible, with the best possible construction of escapement for it, and a balance and hairspring best suited to that movement, they are taken as models and the reduplication system of adjustment begins. The proper size and mass for the balance being now known, different methods of making balances are compared, and that one is adopted which not only gives the best products, but the greatest *uniformity* in quality and action. Absolute uniformity is the keynote of the system.

Scores and hundreds, perhaps thousands of movements of the same style and size are wound, set to time, and exhaustively tested, and are adjusted with the utmost thoroughness and care. When the best possible results have been attained, the perfect balances are compared. If all is as it should be, every one of them will have its screws in the same positions on its rim. But if the screws are in different positions on different balances, it shows that the balances are not uniform, for if they were the adjusters would have found it necessary to bring the screws



to the same positions in order to secure the same performance. Whatever changes may be required, are made, until the process of manufacture secures practical uniformity in the finished balances. Thenceforth it is only necessary for the maker to put the screws in the proper positions, and the balance is already adjusted.

The success of the system depends upon making all of the balances precisely like the model. The same methods must be rigidly adhered to, from the first step in the manufacture to the last. Everything is measured to the ten-thousandth part of an inch to obtain absolute uniformity in size and proportions, and even the screws must be of the same metal, size, weight, shape and positions. If the balances have been made in the same way as the adjusted model, and really are precisely like it, they will necessarily act like it; i. e., they will, without any "adjustment," give the same action as the original adjusted balance. That is to say, they are as perfect, when made, as the model was after the adjusters had exhausted their skill in perfecting it.

This is the theory of the mechanical adjustment system, and practical results prove its correctness. When tested in the movements, many of the balances are found so perfect that little or no change is needed. These balances are classed as "adjusted," because they are of that quality, although their perfection has been obtained by care in their manufacture, instead of by the pro-

cess of adjustment. A very moderate charge will compensate the makers, instead of the heavy expense of the usual adjustment, and



THOMAS W. AVERY.  
ELGIN NATIONAL WATCH CO.

watches with compensated balances can be sold at prices greatly below those when the watches are adjusted in the old way.

Not all of the balances are perfect, however. This could hardly be expected. Owing

to undiscernable differences in the metal or the manipulations, many of them require more or less adjustment. If they are readily brought to perfect action, they are also classed as "adjusted;" if they are not, no attempt is made to adjust them, but they are used in the unadjusted grades of movements, just as they are. All of them are superior to ordinary balances, and they are graded as fair, good or excellent, according to their performance in the trials they have undergone, and are used for the corresponding grades of movement.

It will, of course, be understood that the foregoing details apply more particularly to the balance. There are three distinct adjustments in watch work. The one already referred to is the "adjustment for temperatures," to compensate for the effects of heat and cold, which may make a watch gain or lose several minutes per day if the balance is not adjusted or "compensated"; another is the "adjustment for isochronism," which is applied to the hairspring to make the watch keep the same time whether the balance vibrations are great or small, and so compensate for the variations in the power of the mainspring when it is wound much or little, and for other causes affecting the motion of the balance; and a third is the "adjustment for positions," to secure the same correct running whether the watch is lying on its back, its face, held stem up, stem down, or in any other position. Watches with compensated balances are usually called

# SWARTCHILD & CO., MASONIC TEMPLE, CHICAGO, ILLS.

THE ONLY EXCLUSIVE TOOL AND MATERIAL HOUSE IN AMERICA.

OUR STOCK IS THE MOST COMPLETE IN EVERY DEPARTMENT OF ANY HOUSE IN THE COUNTRY. OUR PRICES ARE THE LOWEST.

**HEADQUARTERS**  
... FOR ...  
**Watch Makers'**  
... AND ...  
**Jewelers'**  
**Supplies.**

*Genuine Moseley Chucks*  
**\$1.00**

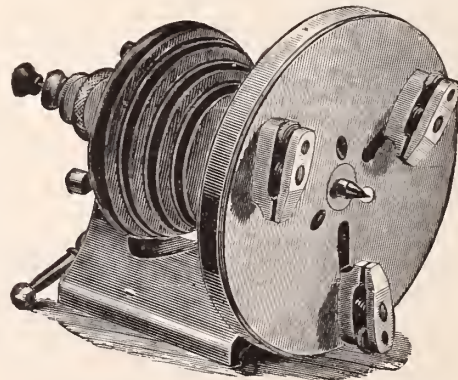

**NO. 2296. COLUMBIA-UNIVERSAL HEAD.**  
This Universal Head will interchange with the Whitcomb and Webster-Whitcomb Lathes, and are warranted as to style, finish, and workmanship of any Head made. In ordering send chuck, or state if for 1½ Whitcomb or Webster-Whitcomb.  
**PRICE AS SHOWN ABOVE, \$12.00.**

We always carry the latest improved tools placed on the market.

*Genuine Whitcomb*  
... OR ...  
*Webster-Whitcomb*  
**Chucks \$1.00**

—LOOK AT THE ABOVE PRICE ON THIS UNIVERSAL HEAD.—

**SWARTCHILD & CO., - - MASONIC TEMPLE.**

If you have not got our 645 page Illustrated Catalogue, please write for it and it will be sent to you Express prepaid. You cannot afford to be without it.



# SUBJECT:



# WATCH CASES.



PAT 1600

WE are continually adding new shapes and designs to our popular line of

## GOLD FILLED WATCH CASES.

*ASK YOUR JOBBER FOR THEM!*

# Bates & Bacon,

167 DEARBORN STREET,  
CHICAGO, ILLS.

11 JOHN STREET,  
NEW YORK.

# Illinois



# Springfield

# Watches.

The  
Reliable Lever  
Setting Movement.

Our Stock is Kept Full and Complete at all Times, so Orders  
can be Filled Promptly and Correctly.

HOWARD,  
ELGIN,  
WALTHAM,  
STANDARD  
AND  
OTHER  
MOVEMENTS.



SOLID GOLD,  
GOLD FILLED,  
SILVER  
AND  
NICKEL  
CASES.

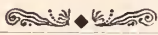

SWISS  
WATCHES.

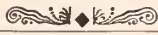

CLOCKS  
OF ALL  
KINDS.



DIAMONDS,  
FINEST 14k.,  
10k. GOLD,  
ROLLED PLATE  
AND  
SILVER  
JEWELRY.



STERLING  
AND  
SILVER  
PLATED  
WARE.



WATCH MAKERS'  
AND  
JEWELERS  
TOOLS,  
MATERIALS  
AND  
SUPPLIES.

"BUSIEST HOUSE IN AMERICA."

Catalogue, 864 pages of illustrations and retail prices,  
which can be used by retail jewelers the same as a  
stock, sent on application, to dealers not having  
received it. Largest Wholesale Supply House for  
everything needed by jewelers.



Lapp & Flershem,  
CHICAGO.



"adjusted," and that adjustment (for heat and cold) is all that most people need. But those who require very accurate timekeepers should take a completely adjusted watch, having all three of the adjustments.

The system which has been explained is not limited to the balance, but is applicable to all of the adjustments. When applied to the manufacture of hairsprings to obtain isochronism, a spring which has been tested and manipulated till it is perfectly isochronal and satisfactory is taken for a model, and others are made precisely like it, thus securing practically isochronal springs without the trouble and expense of adjusting them. Even the Breguet over-coil is as readily produced as any other part. A mould or form is made upon the cover of the box holding the body of the spring. This mould has an external curve of the desired form for the over-coil. The spring wire is closely wrapped over this curve and hardened while held in the form it is to permanently retain. This gives a more perfect spring than can be obtained in the old way.

The adjustment for positions may require rather more labor, but it is obvious that with a perfect movement for a model, and other movements made as nearly like it as machinery and human skill can attain, a minimum of special work should secure a practically perfect adjustment.

The result of this system is that a certain proportion of the movements produced are of the "adjusted" quality as soon as made, another portion are easily brought to that condition, while the rest are excellent,

movement differs more or less from others, requiring independent special adjustment, which labor must necessarily be paid for and included in the selling price. In this respect machine made watches will always be superior to the hand made articles.

Such is the American system of *mechanical adjustment*, the crowning step in practical horology during the nineteenth century.



JACOB BUNN.  
ILLINOIS WATCH CO.

To whom this idea should be credited, is not known, but it was a brilliant conception—and a daring one as well—to apply rigid business principles to the practical solution of some of the most profound and intricate problems in all horology, and to arrange the process of manufacture so as to largely do away with the necessity of adjusting the movements, the most difficult part of the whole work. It shows that those who have had the watch industry in charge have been imbued with the true nineteenth century spirit, and are worthy of their trust. The higher departments of the factories are not open to the public, and outsiders are not informed what new projects are in mind or under way; but it is understood that other improvements are to follow, which will keep the American watch in the van of progress during the twentieth century as well as during the present.

#### ITS PLACE IN HOROLOGY.

What rank should be assigned to the American watch in horology? It embodies no radical change in principle, contains no new escapement or other startling innovation, but it fairly teems with improvements of a practical and common-sense order. Securing a practically uniform motive force without the fuzee and chain is one; hairsprings hardened and tempered in their final form is another; non-magnetic movements is another; the combined uniformity, perfection and cheapness which machinery secures for the individual parts and for the movement as a whole, is another; the improved system of manufacture is another, which none of its rivals has yet adopted in its entirety; the method of producing adjusted movements is another; and a score of other improvements have already been mentioned. The finest American watches are the equal of any in the world for perfect performance, as has been demonstrated by long and thorough competitive trials at international

expositions and elsewhere, while its low-priced grades give service unexcelled by any other sold for the same money. It has fairly revolutionized the practical application of horological laws and principles, and brought really excellent timekeepers within the means of the masses. If quality of product and perfection of methods count for anything, the American watch will stand in the very front.

#### THE WATCH AS A THING OF BEAUTY.

A few words should be said upon a point which has been strangely overlooked, and that is, the watch as a thing of beauty, as well as use. Many of the American movements now turned out, especially the stem-winders, are positively handsome and delightful to the eye. The yellow of the wheels, the jet black polish of the steel, plain or with intricate designs upon its surface, the jewels in their red or yellow settings, the gold or nickel of the plates, beautifully engraved and rayed or damaskeened, the exposed ruby pallets, swinging back and forth, checking the too eager wheels, the swaying sectors of light reflected from the polished balance springs and screws, all form a picture that interests everyone. From the oldest to the youngest, even to the little children, all take keen delight in getting a peep at the works of a watch.

Customers are necessarily prohibited from opening the backs of their watches for obvious reasons. But why should all this beauty exist merely to be seen only by the dealer, and covered and sealed from the owner? Why not utilize it, and get some



D. GRUEN.  
COLUMBUS WATCH CO.

although not perfect. Very superior timepieces are thus obtained, at prices which are very low for the quality, and much lower than would be possible under any other system. For it can only be applied where facilities exist for following an absolutely uniform system in the manufacture, and making great numbers of movements precisely alike. When made by hand, each



AMBROSE WEBSTER.  
AMERICAN WATCH TOOL CO.

practical benefit from it? It costs too much money to waste needlessly. Why not make cases with thick glass backs, so that the movements could be seen without opening the case? By giving the glasses a wide support in the bezels, they would be practically secure against breaking. The bezel should be prevented from coming off easily by tight



fitting, or preferably by screwing on, and then kept from moving by a screw interlocking with it, while the movement would be made inaccessible to any one but the watch-maker. The wide bezel and the central rim of the case could be ornamented by engraving or chasing, or could be worked into fancy shapes, or be jeweled to suit the most expensive tastes.

## Engravers' Type.

A Rubber Type in new styles specially adapted to Engravers' use. Seven different sizes now ready.

*Minnie S. Foster*  
*Sir Walter Scott.*

Does away with all tracing.

Letters are stamped upon the article in clear cut script or old English.

The outline can readily be engraved by even the apprentice.

Type made on new principle, bevel edged; alignment guaranteed.

Every Engraver should have it.

Write for particulars.

WM. H. DIETZ,

117 Dearborn Street, Chicago.

If the cases were made as suggested, watches would be more valued and admired, and the trade would undoubtedly be benefited. Watches would be bought and worn as pleasing ornaments.

Even the most jaded votary of fashion would admire the differently colored metals and their ornamentation, the jewels, the untiring wheels, the bounding life and motion, and would wonder at the ingenuity and skill which could contrive and make such a marvel. As one can watch the ceaseless antics of an imprisoned insect for hours with interest, so would he be equally interested in watching the wheels and other pieces doing their appointed work—meeting and passing, interlocking but never clashing, while the balance constantly flies to and fro with lightning swiftness, like an imprisoned spirit seeking to escape. And it truly is so; for it is a portion of nature's energy, temporarily imprisoned in the springs, which turns the wheels and causes all this animation in a struggling for deliverance. But the mechanism allows it to escape only bit by bit, by giving a "tick" as a ransom for the liberation of each bit. And when the springs have run entirely down and the imprisoned force has all escaped, whither has it gone?

### ITS MERITS IN GENERAL.

Take it all in all, the American watch is a noteworthy product. Whether it is considered with regard to its mechanical perfection, its cheapness, its quality, its time-keep-

ing properties or its commercial advantages, its place in horology, its perfect system of manufacture or the many improvements which that system renders it possible to devise and execute, its value to individual wearers or the benefit arising from placing good timepieces within the reach of the masses—it would be difficult to find a better type and example of nineteenth century ingenuity and progress than the American watch of to-day.

### THE PORTRAITS.

In the compass of such an article as this, it is hardly possible to comprehend in the matter of portraits all the men who have been instrumental in bringing the American watch to the high standard it occupies to-day. A. L. Dennison, Edward Howard, D. F. Appleton, Thomas W. Avery, Jacob Bunn, Ambrose Webster and D. Gruen are but a selection from a goodly list of men who have brought out striking ideas, including Royal E. Robbins, C. S. Moseley, D. H. Church, E. A. Marsh, J. B. Gooding, Chas. W. Fogg and Chas. Vander Woerd, of Waltham, Geo. Hunter and Geo. E. Hunter, of Elgin, D. A. A. Buck, of Waterbury, while among those who have invented minor matters should be mentioned W. W. Hastings, S. T. J. Byam, Geo. E. Hart, and Henry J. Cain, while the names of Chas. D. Rood, Henry W. Price, W. E. Moore and Geo. E. Knight should not be forgotten in connection with the various companies.

# THE AURORA SILVER PLATE MFG. CO.

AURORA, ILLS.

Man's of Superior Hollow and Flat Ware IN GREAT VARIETY.

Many new and handsome Novelties in fine Electro Silver Plate, are being brought out for the Season of 1894.



The "AURORA" FLAT WARE is not excelled in quality or finish by any brand in the U. S. Extra heavy "Hotel Ware" a specialty.

No. 276 B. C. WATER SET.

We have just opened a complete line of samples in our new and spacious quarters, at No. 120 Sutter St., San Francisco, Cal., with Mr. J. B. Whitney as Manager.



**BIPPART & CO.**  
 MANUFACTURERS OF FINE **DIAMOND JEWELRY.**

NEWARK, N.J.  
 CORNER MARSHALL & HALSEY ST'S.  
 NEW YORK OFFICE, 19 MAIDEN LANE.

BROOCHES CHATELAINES  
 LACE PINS HAT PINS  
 SCARF PINS CUFF PINS  
 EARRINGS NECKLACES  
 BRACELETS RINGS

IN STRICTLY 14 K. WITH OR WITHOUT DIAMONDS.

**WATCHES**  
**J. T. SCOTT & CO.**  
**JEWELRY**

**DIAMONDS**

**Watches**  
**JEWELRY**

4 Maiden Lane, N.Y.  
**Watches**

Labels on the diamond stack:  
 BROOCHES  
 LACE PINS  
 EAR DROPS  
 STUDS  
 SCARF PINS  
 SINGLE AND  
 FANCY  
 STONE RINGS



# Alvin Manufacturing Co.,

## 860 Broadway, New York.

Silver Deposit Cologne.

1000 FINE.  
1000

Factory, Irvington, N. J.

Book Mark  
and  
Paper Cutter



California  
Midwinter  
Exposition  
Souvenir Spoon.



FRONT.

**\$3.50**



Cut Exact Size.

**\$3.50**

California  
Midwinter  
Exposition  
Souvenir Spoon.



BACK.

Bag Tag.



Silver . . .  
Deposit . . .  
. . . Wares.

For the purpose of introducing these beautiful goods to new localities, we offer the above beautiful specimen at the remarkably low price of \$3.50 each.

Over 1000 Different Designs of

### Decanters, Colognes, Atomizers, Ink Stands, Flasks, etc.

PHOTOGRAPHS SENT ON APPLICATION.



## A QUARTER CENTURY IN THE PRECIOUS STONE INDUSTRY.

*George F. King,*

A COMPARISON of the literature that existed in 1869 on the subject of precious stones with that of 1894, shows at a glance the immense revolution that has taken place in the short interval of twenty-five years. Among books, Feuchtwanger's "Treatise on Gems," was the standard reference on this side of the Atlantic, and the works of Kluge and Barbot abroad. We had none of the five editions of "Precious Stones," "Great Diamonds of the World," and "Pearls and Pearlring Life," bearing the name of Edw. W. Streeter. The second edition of his "Antique Gems," "Antique Rings," and other contributions to antique gem lore, by the Rev. C. W. King; the works of A. H. Church, S. W. Burnham, A. C. Hamlin and others were added to our gem lore. The fifth edition of the "System of Mineralogy," that marvelous compendium of mineralogical science by James D. Dana, appeared in 1868; the sixth edition in 1892, this monumental undertaking containing 1,134 pages, mainly brought up to date by Edward S. Dana, a son of the great Nestor of mineralogy, although at such an expense of his physical condition that he has not fully recovered, even after one year of rest.

The importance of statistics on the subject of precious stones has been so fully recognized by Major Powell, of the U. S. Geological Survey, that each of the nine volumes of mineral statistics edited by Dr. David T. Day, the Chief, has contained an article on the subject; and the 11th U. S. Census had a special investigation made and a report printed in the volume on mines, in charge of the same eminent authority; while at the present time the United States Fish Commission is preparing an investigation as to the occurrence and production of pearls in the United States.

In 1868 the pearl fisheries of the Little Miami and other Ohio rivers were prolific. In the past five years there have been produced more than a quarter of a million dollars' worth of pearls from Wisconsin, and more than one-half that amount from Texas, Tennessee and Kentucky. At that time the discoveries of diamonds in South Africa had scarcely begun, and none of the four now great mines had been opened. We little dreamed then that during the coming quarter of a century nine and one-half tons of diamonds selling for more than \$300,000,000 uncut and for \$600,000,000 after cutting would be added to the world's wealth, an amount more than twice as much as was known before; that a corporation whose market value is quoted at over \$90,000,000 would control over 90 per cent. of all the output, and would regulate and maintain the price, resulting in the establishment of diamond

cutting industries such as were never before thought of, and by which tens of thousands of men would be employed as cutters, polishers and dealers; this again being revolutionized by the establishment of immense mills, at which the cutters hire only the benches at which they do the cutting.

The diamond mines of Brazil which had chiefly supplied the world have now become almost an unknown factor in the production of this gem, although the Canavieras Mine in Bahia about ten years ago yielded a large quantity of remarkably fine white stones. In 1869 diamonds had been cut only for one year in the United States. In 1892 nearly as many diamonds in value and more in weight were cut than the entire import of 1868.

Henry Morse, of Boston, had scarcely commenced the industry of diamond cutting in this country, which he subsequently continued for more than 18 years, breaking down the superstition about the difficulty of acquiring the art, by becoming master of it himself and teaching it to American apprentices. In 1870, I. Herrmann started the New York Diamond Cutting Co., in New York city. In his attempt to establish this industry in the United States, he has sunk three fortunes, but he still has faith in our ultimately being a diamond cutting center.

Both Mr. Morse and Mr. Herrmann taught the art of diamond cutting to girls, which lead to their taking up this industry not only on this side of the Atlantic, but to a large proportion in France, Switzerland and other European countries. It was really these pioneer diamond cutters that increased the taste and proficiency of the cutters abroad; for cutting diamonds as they did, with mathematical precision, created a demand for such work here which the foreign cutters had to acquire the skill to meet; and the result was a style of diamond cutting which for mathematical precision had never been excelled before.

In Mr. Morse's shop, in 1872, C. M. Field invented the first diamond-cutting machine, which has made it possible to cut diamonds faster and with more precision than by the old hand process. It has been adopted in some of the larger establishments in the United States, although abroad its true value has not yet been fully recognized.

Sir Henry Bessemer has devised for the London cutters an endless rope that furnishes the power for as many as ten diamond mills at the same time, thus doing away with the long belt for each machine. Now it is suggested that an American dynamo motor company furnish a separate perpendicular dynamo for each mill, thus dispensing with the belts entirely, saving power, and making it possible to cut diamonds with more cleanliness than with a moving belt.

This is also of interest when one realizes that smaller dynamos could be attached directly to precious stone polishing wheels to the gem-cutting lathe or, better still, to the revolving drill, such as is used for the dentist's work and gem engraving, thus producing, as in the days of ancient Greece and ancient Rome, more artistic finish than would be possible by the horizontal lathe method. This method of gem engraving was fully described in THE JEWELERS' CIRCULAR some eight years ago.

This subject of diamond cutting in the United States is worthy of consideration when we remember that duty was paid on about \$15,000,000 worth of diamonds between June, 1892, and June, 1893, of which the rough stones surely did not cost more than one-half; and allowing one-tenth for power and rental and one-tenth for profit, it would still leave \$1,000 a year for four thousand diamond cutters, if the cutting had been done in this country. The deplorable condition of most of the diamond cutting industry in this country is due to the inability of the dealers to obtain rough at first hand.

There have been imported into the United States since 1868, about \$175,000,000 worth of diamonds and there are to-day on the continent four stones weighing more than 55 karats each. \$600,000 added to the world's wealth in the most concentrated, portable and ornamental form, more convertible than anything except gold and silver, in the accretion of which cities like Kimberley have been built, Amsterdam and other cities sustained, proves the great economic importance of the invincible and beautiful precious stone.

France was an empire in 1869, and Napoleon III. little thought that the imperial crown jewels would be dispersed and that an American house would be the purchaser of more than one-third of them. The famous Duke of Brunswick collection of gems, and the Hope collection of jewels have been dispersed within this time, the yellow diamond of the "diamond duke" being one of the great features of the Centennial Exhibition.

All the known diamonds weighing 100 karats or over could then be counted on the fingers of the two hands. The number has been more than doubled since. Scarcely 10 years ago the finest large brilliant was the Victoria or Imperial, shown at the Paris Exposition, since acquired by the Nizam of Hyderabad, for about \$2,000,000, the option of \$500,000 having been received by Jacob of India, immortalized by Marion Crawford as Mr. Isaacs, who in June, 1893, found a 961 karat stone. The Jagersfontein, or Excelsior, now in the innermost vaults of the Bank of England, it is rumored, Emperor William wished to acquire for \$5,000,000, although past experi-



ences would seem to prove that that monarch would prefer to add glory to his crown by an equal expenditure on his army, rather than on the greatest known diamond.

Less than 10 years ago diamond was first discovered in a meteorite at Novo Ureii, Russia; and three years ago the presence of diamond was recognized in the meteorite found at Cañon Diablo, Arizona. The latter was detected by Foote, described by Koenig and Huntington, analyzed by Friedel, and, finally its hardness tested by myself and Dr. Huntington, who successfully polished two diamonds with the powder of the meteorite in September last, in the Tiffany cutting exhibit in the Mines Building at the World's Columbian Exposition.

At least a score of chemists and others believed that they had produced artificial diamonds; but it was not until 1892 that Moisson, of the French Academy, attained that chemical triumph and long-sought-for glory, although the diamonds were microscopic in size. At that time Frémy and Feil had experimented for years to produce artificial rubies, spinels, etc. It remained for Frémy in 1889 to present the synthesis of the ruby to the French Academy, although he did not succeed in producing rubies larger than a pin's head. A Zurich experimenter, through a Genevan diamond cutter, once placed upon the Paris market great quantities of the so-called reconstructed rubies (not really such, however, but artificial gems), only to have them taken back to the venders, who were compelled to refund the money.

Although Cellini boasted in his time that he used a blue coloring matter (indigo) to make a yellow diamond appear white, and Ferrandus, in 1695, published an article on the subject, it remained for unscrupulous dealers in the latter part of the past quarter century to perpetrate the blue aniline swindle to the extent of some millions of dollars on the diamond fraternity of both hemispheres.

At the commencement of this quarter of a century there was not in the United States a single collection of gems on public exhibition. To-day we have the Tiffany collection presented by J. Pierrepont Morgan to the Museum of Natural History in New York city; a fine collection at the United States National Museum in Washington, a smaller collection in the State Museum at Albany, N. Y., and the Garland gift to the collections of Harvard University at Cambridge, Mass., the last containing many fine examples of gems in their natural form, among other things the richest collection of tourmalines in existence, collected by Hamlin, father and sons, of Bangor, Maine, for the past 73 years, and some of the finest existing Uralian gem minerals.

The remarkable collections of antique gems of that greatest of writers on antique gems, the Rev. C. W. King, the collection of Babylonian cylinders of the Rev. W. Hayes Ward, the Cypriote collection of antique gems of Gen. L. P. di Cesnola at the Metropolitan Museum of Art, and the great collection of Dr. Maxwell Sommerville in the Museum of Archæology at the University

of Pennsylvania, Philadelphia, give this country a fair representation of these ancient monuments of art and skill that are rapidly becoming more priceless and unattainable.

Ten years ago quantities of the finest sapphires ever found were brought to light in Cashmere. So many and so fine were these gems that for a time the price of sapphires was lowered in the markets of the world. Their price has now fully appreciated and the then apparent overabundance has been consumed by the world's demand.

More recently emeralds were reported from Vegetable Creek, New South Wales, but as yet the mines in the United States of Columbia have little to fear in the way of competition, and if the recent renewal of the lease of these mines (December, 1893) was made to the right parties we may hope to see as fine gems as were ever found before.

Remarkable crystals of emerald were obtained in Alexander County, North Carolina. Commercially little was realized from these gems, although the hiddenite found with them yielded some ten thousand dollars' worth of gems.

The agatized wood of Arizona was one of the great features of the 1889 and 1893 exhibitions, and over \$50,000 worth of it has been sold. The garnets of Arizona and New Mexico are matchless as specimens of color, and several thousand dollars' worth of them are annually sold.

The search for gems in this country received something of a set-back at the time of the famous Arizona swindle of 1870-71. Since then more than a quarter of a million dollars' worth of turquoises have been obtained in New Mexico. A few diamonds have been found in California, North Carolina and Georgia, and they have since then been observed in Wisconsin, Kentucky and Montana.

We have yet to learn that the \$2,000,000 Montana Sapphire Mining Co. are paying dividends from earnings, although the English nobility did attend their very formal introduction to that greatest of the world's centers, London. The sales in London last year are only quoted at £158, and a deficit of £6,000 was reported at their last meeting instead of the 40 per cent. dividend hoped for by the stockholders.

Until within the past decade we knew as little about the ruby mines of Burmah and the marvelous gems supposed to be in the possession of King Thebaw of that country, as was known a century ago. An English syndicate, through the efforts of Streeter, of London, after many vicissitudes obtained a grant from the English government, who secured Thebaw's gems, and they are now shown under plain plate glass as a part of the regular collection at the Indian Museum in South Kensington, England, instead of being relegated to the jewels at the Tower, so did their value pale into insignificance by comparison.

The mines have not proved the profitable investment which was expected on the day

when the London police were compelled to club the millionaires away from the subscription office, so great was the demand for the stock; and fine rubies, although not "above price," can only be obtained at a very high cost, even higher than ever before.

From Siam we have obtained rubies that frequently are very fine and of great value, a number of mines being worked in that small kingdom.

The great quantities of opal from the large discoveries of fine opal in Queensland and New South Wales, the mines in Washington State and Idaho, and the opening of many new mines in Mexico, have been absorbed, opal being less of a drug than it was in 1869. This is sufficient evidence that the unfounded and unfortunate superstition has been vanishing with great rapidity. This contrasts favorably with the moon-stone which is almost universally believed to bring good luck, so much so in Ceylon that it is always sold on a yellow cloth (the holy color). Owing to the finding of almost unlimited quantities, it has gradually decreased in price until it is used now only in the cheaper jewelry, except in remarkable examples.

Within these 25 years the jade discussion has been participated in by many authorities, and was finally disposed of as being a chemical and not an ethnological question. The discussion originated with Dr. Heinrich Fischer, of Freiburg Baden, who published an exhaustive volume on the subject, the entire results going to prove that all of the jade and jadeite found in Europe as well as that found in Mexico, was of Burmese origin. Seven letters appeared in the *London Times*, the discussion being participated in by many of the most eminent men in Europe. It has been conclusively proved that the jadeite of Mexico is of Mexican origin, that that from Alaska is of Alaskan origin, and the specimens from Europe undoubtedly originated in European localities.

At that time cat's-eyes, asterias, tourmalines, spinels, zircons and chrysoberyls were almost unknown, except to the few gem collectors. Because the Duke of Connaught gave his bride a cat's-eye engagement ring, the stone became fashionable; in the search for it, alexandrites, finer than were ever known before and of great size, chrysoberyls, zircons and other fine gems were found in quantities and brought from Ceylon and Cashmere. Topaz has since then been found in Maine, New Hampshire, California, Mexico, Madagascar and Japan.

Demantoid green garnet, generally erroneously called olivine, so phenomenally popular for some years, had not yet received a name; and every month brings its new surprises although we safely refer to the past quarter century as the most eventful in the history of precious stones.

A quarter of a century ago that many sided genius Lebrethon, cameo-cutter, designer, actor, etc., Bonet, Avet and many other artists, at least 25 in number, pursued



# DAY & CLARK,

"Manufacturers Only."

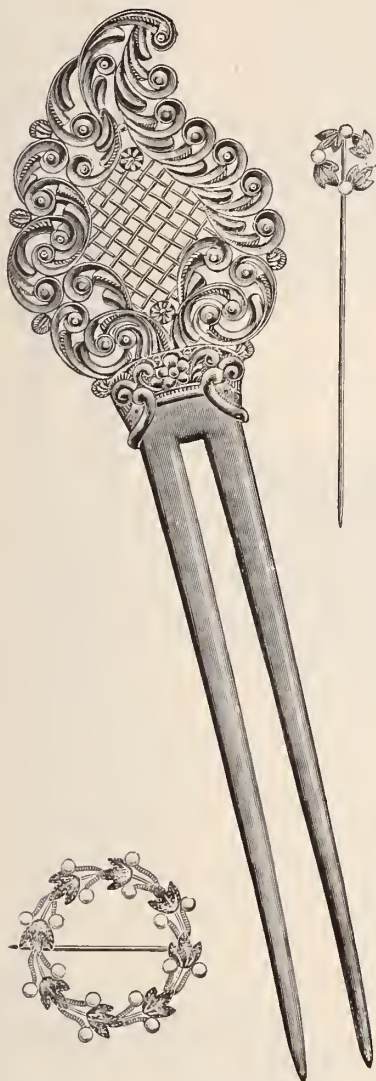

FULL LINE

Wreath Scarf Pins and Brooches,

Pearl, Diamond and Emerald Set.

NOVELTIES IN HAIR COMBS

in 14-kt. Gold and Sterling Silver.

23 MAIDEN LANE,

HAYS BUILDING.

NEW YORK.

## ANNOUNCEMENT.

# Theodore C. Steinhaus,

Late with Samuel C. Jackson for 26 years, as Manager 4 years.

MANUFACTURER OF

## Fine • Cases • and • Trays

... FOR ...

### JEWELRY, SILVERWARE, &c.

SAMPLE CASES AND TRAYS FOR TRAVELERS.

FANCY HARD WOOD CHESTS FOR SILVERWARE, &c.

Respectfully soliciting a share of your patronage,  
I am, Yours Truly,

THEODORE C. STEINHAUS.

OFFICE AND FACTORY,

10 MAIDEN LANE, NEW YORK.

Have you ever had any trouble with  
turquoises?

The turquoises mined and sold by the  
Azure Mining Company DO NOT  
CHANGE COLOR.

Be sure you get Azure turquoises.  
Every Stone has our trade mark  
 engraved on the back.



HAT PINS,  
GOLD, \$2.25  
SILVER  
\$5.00 DOZ.

GOLD HAIR PIN, \$6.75  
SILVER, \$1.30

# 1894-PRICES.



BEST ALL SILK WEBBING, \$2.00

WE ARE THE ORIGINATORS OF THIS STYLE OF BELT AND WE PROPOSE TO HOLD THE TRADE ON THEM.

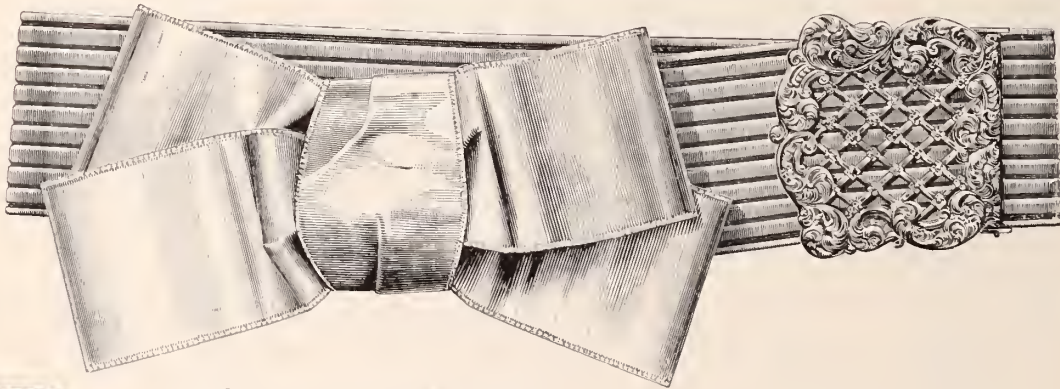

BEST SILK ELASTIC, \$2.00 PAIR.

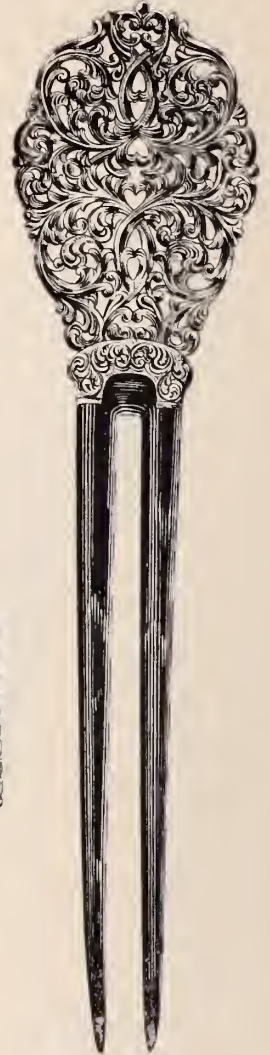

HAT MARK, \$4.00 DOZ.

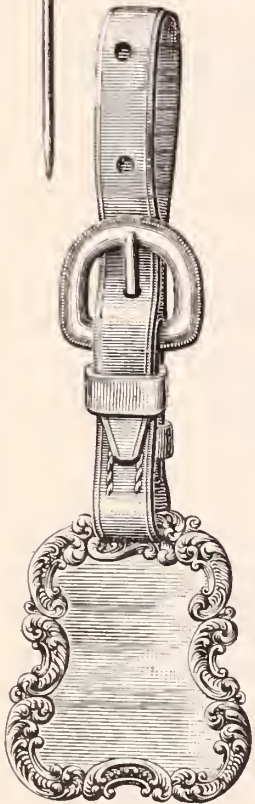

BAG  
TAG,  
80 CTS.  
EACH.



COAT HANGER, \$5.50 DOZ.



UMBRELLA STRAPS,  
GOLD, \$2.00 EACH,  
SILVER, 25 CTS. EACH.

**UNGER BROS.,** Makers of Fine Jewelry, In 14 kt. Gold and Sterling Silver, (.925 Fine,) at Salable Prices. **192 Broadway, NEW YORK.**



the artistic calling of cameo-cutting. To-day, Bonet alone, and a few assistants, follow it as a profession. Our great sculptor, A. St. Gaudens, had given up this profession only a few years before to take up the great art which has since immortalized him. But he has yet a difficult task before him in educating some Senators to an artistic Columbian Exposition medal.

In 1869 the lapidaries, Cottier, M. Fox and Tournier were in their prime; all except the latter have now been superseded by their sons.

The present extensive use of burglar-alarm safe deposit boxes affords greater safety

for the jewels of the dealer and the private owner than ever the jewels of the imperial houses had with their armed forces. By the expenditure of merely a nominal sum, family jewels receive absolute protection from thief or fire which the monarchs of foreign lands with their guards armed to the teeth occasionally failed to attain.

The safety of the English and Continental mails seems very apparent when one realizes that nearly all of the \$300,000,000 worth of rough was shipped from the Cape to London by mail and again sent from England to the Continent to be cut. When one considers that no French or English merchant would

have a moment's doubt that his package of diamonds or precious stones would go safely to its destination: that a package mailed in London one day would be delivered in Paris on the forenoon of the following day, or that a package shipped in Paris in the afternoon would be delivered in London on the morning of the next day, it would suggest that if a similar system of insurance and safety be secured our American merchants it would serve as a greater medium of exchange, than even our present methods of shipment. A universal movement in this direction on the part of the importers might bear good fruit.

## THE JEWELRY FASHIONS OF THE FUTURE.

*Langley Humphreys,*

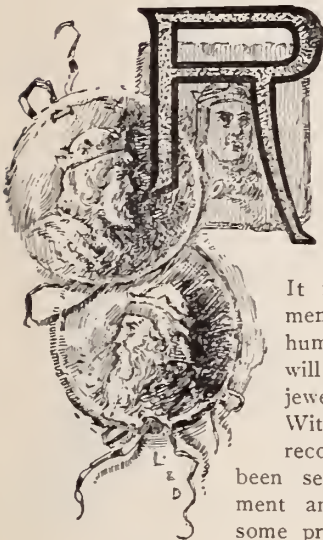

REALLY we find the love of ornament antedates the necessity of clothes. The painted Pict was long able to dispense with breeches.

It is this fundamental trait in human nature that will perpetuate the jewelers' trade. Within everybody's recollection has been seen the effacement and the rise of some prosperous business. The jewelers'

trade is one of the most ancient, most honorable, most prosperous. It marches with civilization, and holds its own alike with dynasties and democracies.

It is interesting to observe that in articles of gold, silver and gems, we have scarcely gone beyond the earliest Biblical record. Gold is an old story in the second chapter of Genesis. There is no record of Sarah's ornaments, but the abundant mention of Rebecca's earrings and bracelets made her envied by many a Sunday school little girl, who in this way made her acquaintance.

Thenceforth rings, necklaces, earrings, breast pins, bracelets, tiaras, jeweled daggers, girdles, pins, combs, but repeat themselves according to the taste of the age. An inspection of the Cyprian jewelry at the Metropolitan Museum shows how completely the ladies of antiquity had their jewel cases equipped. To these we have been able to add very few articles, the watch being the most conspicuous.

Nose rings and lip rings have certainly gone out of fashion. No jeweler could be induced to make them except on special

order, and would then have to be persuaded that the person was sane or in amateur theatricals in order to get his bills paid. Nor is there great demand for anklets; garter clasps may be said to have taken their place.

If the past may be taken as a guide, and the wisdom of ages seems to warrant its acceptance, the articles of the jewelers' trade in the future will be pretty much those of the past, subject to the usual waxing and waning of fashion. Certain tendencies, however, may be remarked, and on these a few predictions based.

There seems to be no probability of long earrings ever being revived. Diamond solitaires, came for a long time to be tolerated on their merits, but the screw is more refined.

Personally one may assert belief in the persistence of what is known as women's distinctive dress, and this is the teeth of the efforts of all the dress reformers. Women are built both architecturally and of materials that are intended for beauty. No costume that has ever been devised for them compares in suitability and adaptability with that which they have as a sex evolved. Drappings and swathings are intended for softness and feminine grace. These, so long as they last, will demand pins, and buckles, and girdles, and clasps. With these, in the eternal fitness of things, will always go bracelets, necklaces, tiaras, pendants and other purely feminine adornments. These will always be meet for the finest resources of the jeweler's art.

But, and it is right to put the thing squarely, if the time comes when women will approach more nearly the sex that depends on buttons alone, then jewelers will be among the first to feel the change. As men have been obliged to give up necklaces, crowns, bracelets, jeweled buckles, so will women.

Madame Dieulafoy, who is one of the

three women permitted by the French Government to don men's clothes, has recently had something to say on this subject. The tentative efforts of the dress reformers she holds in great scorn. Their garments are primarily inartistic, and are not convenient enough to compensate for their loss of beauty. If women do make any change in their clothing, she predicts that they will deliberately adopt that of men, which she regards as the last word to be said in the way of useful convenient dress.

Pinero's play, "The Amazons," which was produced in London last year presented a duchess' daughters in such fetching masculine garments that their admirers in the audience declared that the actresses never seemed so attractive. This same play is to be brought out in America at the Lyceum Theatre. Its success may be so great that before the end of the Summer the woods may be full of women in Norfolk jackets and knickerbockers.

Of course, if this is ever the case and women once get into trousers, the jeweler will still have his business, but it will be greatly changed.

## OTHERWISE THAN WISE.

O'HOLLAHAN (reading card attached to statuette of Venus).—Tin per cint. off! Begob, there be more off thin that.

### BUSINESS FOR THE MONT DE PIÉTÉ.

KNOWLES—If the tariff as now proposed is passed, I suppose diamonds will go up.

BOWLES—Won't affect me. Mine are up already.

### RIVALS MARCO POLO.

FIRST JEWELER—Is your new man, Valise, a good traveler?

SECOND JEWELER—Oh, yes a very good traveler, indeed. He's been with me two weeks, and he's used up a mileage book already.

## Don't

Be deluded, but send your old gold and silver direct to the refiner who makes a specialty of this business, and can give you correct valuations. Don't

## Flirt

With Dame Fortune, by sending to every one promiscuously. The "Old and Tried is Always the Best," and our plan has given general satisfaction, and

## With

The positive assurance that we will remit immediately on receipt of consignment. If our offer should not prove satisfactory we will return consignment intact and pay all charges. You take no chances whatever. Every jeweler has more or less of a collection of gold and silver on hand. Now is the time to collect it. Grasp fickle fortune while you can, and do not let

## Her

Escape you.



— — — — —

# GOLDSMITH BROS.,

## Gold and Silver Refiners

## and Assayers,

63 and 65 Washington Street,

- - - -

Chicago, Ill.





## THE ART AND DEVELOPMENT OF AMERICAN SILVERSMITHING.

WITH AN INTRODUCTION BY J. H. BUCK.

IN the first busy centuries of the Anglo-Saxon race in America, when the rude forces of the continent had to be conquered, and the whole of men's energies were devoted to the development of the natural resources of the land and to the procuring of the daily necessities of life, the young country had no time for the formation of a national style in art or letters. The good old methods of the mother country sufficed for them and the people were content to run in the lines that their parents and grandparents had followed. But with advancing civilization, with the greater wealth and the consequent leisure that it brought, came the time for them to assert their independence otherwise than politically. The day of imitation had ceased and American taste began to be no longer the mere echo of European culture.

There is an old saying, tracing the decay of English art during the first half of the present century, that if all that was supposed to represent English art in the great exhibition of 1851 was piled in a heap and made into a bonfire the world would not be the poorer. This saying would certainly not apply to the art at the Centennial Exhibition in 1876, at Philadelphia, previous to which great advance had been made both in design and workmanship. This great exhibition gave a fresh impetus to the silversmith's art. American manufacturers were then able to compare the best products of all nations with their own. After the exhibitions at Paris in 1878 and 1889, and Chicago last year, the superiority of American design and manufacture was universally conceded.

Instead of our silversmiths being hampered by Hall marks or a slavish adherence to tradition or waiting as in the older countries, to be educated by public wants, they are ever striving to produce articles in advance of the prevailing taste and thus educate the public to appreciate their beautiful productions.

A recent English writer observes: "As in their architecture, so in their subsidiary arts, the Americans seem unconsciously to assimilate, in a degree unknown to nations fettered by the bonds of tradition, all that is good in the art work of other people and at the same time to impart to the conglomeration thus obtained a distinct flavor of their own individuality."

In no other branch of American art, and

in no other American craft, is this quality more patent than in silver work.

By the aid of trained designers, by the eager adoption of inventions and improved systems of manufacture, the advance during the last quarter of a century has enabled the majority of our people to enjoy articles which previously were a luxury only afforded by the few. This applies principally to domestic work, but large pieces such as prize cups, trophies, presentation and centerpieces are now produced equal to, if not superior to any modern work.

Great advance has been made during the last decade in ecclesiastical silverware. Here the true guide has been followed, namely, the spirit of the devout silver workers of mediæval days. Church work to-day in America can compare favorably with that of the older continent.

### SPECIAL WORKS IN SILVER.

The artistic instincts and manipulative ingenuity of the silversmith find their most striking expression in the production of special prize cups, trophies, punch bowls and kindred pieces. In such works the value of the raw material, silver, lies not so much in its pecuniary cost, as in its adaptability to the various processes entering into the design of the article considered as an ensemble. Casting and appliqué work, chasing and repoussé, etching and engraving, yield the greatest measure of effect when employed in the manipulation of massive silver, while with regards to modeling, this metal is second to none, bronze which is poorly adapted to the several processes so essential in the production of works of a commemorative and honorary character, as cups, vases, bowls and the like, being employed only on account of its durability and inexpensiveness.

It is in this branch of artistic endeavor that the American silversmith of to-day especially excels all foreign competitors. His work *per se* possesses not the multiplicity of detail of the German, nor the ethereality of the Frenchman, nor the cold stolidity of the Englishman, but is rather a combination of the apparent beauties of all; the attention to detail of the one, and the grace and massiveness of the others. Except where specific orders are given, the American designer breaks away from the tiring conventionalities, utilizing the deli-

cate outlines of the Greek or the more rigid though eloquent lines of the Egyptian, under newly devised combinations as a setting to his own conceptions of decorative elements.

This journal has exercised unusual endeavor in depicting and describing these special works, as it has considered each piece to be a lesson in the art of silversmithing. The professor, in the belief that art can have no advance, discourses on past models, inviting imitation rather than originality. Let him, if his dissertations bear in any respect upon silversmithing, hold up works such as the silverware companies of America produce, works which are the embodiment of all present knowledge of the art. Let him remember that even Cellini and Flaxman as silversmiths, find more versatile expression in the able American designers of the present time. The famous cups and hanaps of the past, preserved in museums and private collections, would be derided to-day, if produced as lasting works, as ungainly and trivial. The most ordinary designer of New York or Providence would not be proud of his conception, nor the manipulator of his handiwork, if the piece possessed no more art than such treasures.

Necessity is the mother of artistic achievement, as she is of invention. The designer of fine special works in silver has been evolved by the positive demand for such works. The truth of this statement was abundantly proved by the display of about 200 special trophies in the beautiful white metal, that the Whiting Mfg. Co. made in their windows during the Summer last past. The display could serve as a museum of modern silverware of the highest character. Here it was evidenced that the brain of the American designer knows no limit to its fertility. The realms of mythology, folk lore and history find ample expression; while the sciences of botany, zoology and ichthyology yield up their stores of knowledge, and "all ocean's waters" appear as in nature or in allegory.

We should not have the temerity to place silversmithing among the fine arts as painting, music, sculpture and poetry, but among the lesser arts its position is unassailable and assured.

B. F. S.

In giving the stories of the many firms that maintain the high reputation of American silverware, it may prove most proper



to treat them in chronological order. It is a matter of too fine a discrimination to arrange such a series in the order of the importance of the firms.

#### DOMINICK & HAFF.

The firm of Dominick & Haff, according to the chronology customarily employed in historical sketches of commercial houses, can veritably trace the foundation of their business to the latter half of the eighteenth century, though it has been the last quarter century that has seen their greatest development. The present concern established themselves in business under their own name, in 1870, succeeding William Gale & Son, who manufactured silverware in all its branches, and who were at that time looked upon as the oldest established firm of silversmiths in the country. William Gale had been an apprentice of Peter and John Targee, who had succeeded to the business of John Vernon, silversmith, of Jacob St., New York, during the latter half of the eighteenth century. Though not positively known, many facts go to prove that William Gale bought out the plant of the Targee brothers. He established himself in 1821.

In the early years of their establishment Dominick & Haff devoted themselves exclusively to the manufacture of silver small wares, and acquired a wide reputation for their vinaigrettes, chatelaines and other fancy articles. Following this period they developed a large business in hollow ware. In 1877 the firm's office and factory were entirely burned out, in the destructive fire that devastated the Waltham building in Bond St. They immediately moved into 7 and 9 Bond St., where they had increased facilities for business, and began to manufacture all varieties of articles in silver.

The firm remained in this location but a short time, when, removing to 1, 3 and 5 Bond St., into the reconstructed Waltham building, they purchased that part of the plant of the Adams & Shaw Co., as tools, fixtures and patterns that related to the manufacture of silverware and which the latter concern had previously purchased from John R. Wendt & Co. This purchase enabled the firm to give constant employment to about one hundred men. They manufactured a general line of silverware.

In the Summer of 1884 the firm removed to the building at the corner of Broadway, 17th St. and Union Square. At first they occupied the entire sixth floor and a part of the basement. Soon the factory again assumed proportions too small for the business, and in the Spring of 1891, the fifth floor of the same building was added. At the present time this extensive plant, occupying two floors of a large building running from 17th to 18th Sts., and a goodly part of the basement is a beehive of industry, every available foot of space being utilized. The present force numbers over 200 individuals.

In the Spring of 1888 the firm was organized as a joint stock company. In the

organization several of the clerks were given an interest in the enterprise. The officers elected were: president, H. B. Dominick; vice-president and treasurer, L. B. Haff; and secretary, A. Dominick. A few weeks ago occurred the death of L. B. Haff. The house of Dominick & Haff have been uniformly and phenomenally successful. Starting as one of the smallest silversmithing concerns, they are recognized to-day as one of the largest.

#### GORHAM MFG. CO.

The marvelous development of the Gorham Mfg. Co. is a potent illustration of the great results which the economic conditions existing among the industries of New England, combined with the exercise of mechanical skill and the employment of high artistic ideals in the productions may achieve. Jabez Gorham is generally designated as the father of the business, though to his successors are the great growth of the enterprise and its wide spreading ramifications justly due. Jabez Gorham was born in Providence, R. I., on Feb. 18, 1792, and as a boy was apprenticed to Nehemiah Dodge who began the manufacture of jewelry in 1795. After attaining his majority he with Christopher Burr, William Hadwen, Geo. C. Clark and Henry G. Mumford, formed a partnership which lasted five years when it was dissolved, Mr. Gorham continuing alone. He pursued the manufacture of jewelry until 1831. In that year Mr. Gorham began manufacturing silver spoons, in partnership with Henry L. Webster, of Boston, who was a practical spoon maker. The firm name was Gorham & Webster. They occupied a corner of the lower story of a little building, but the shop was soon increased to include that story. The process of manufacture was extremely crude, two men by hard work being able to make in a day two dozen teaspoons, no two, however, alike in shape or weight. For nine years nothing was made but spoons, thimbles and silver combs and an occasional napkin ring or fork. At 50 years of age Mr. Gorham retired from the business, being succeeded by his son, John. He died suddenly on March 24, 1869, at the age of 77 years.

In 1841 the concern became J. Gorham & Son, composed of Jabez Gorham and his son, John. Mr. Webster at this time returned to Boston, the reorganized firm buying his interest. On the death of his father and on his becoming sole proprietor of the business John Gorham retained the old firm name. In 1850 he determined to take possession of a field of silver manufacture not yet occupied. His business had not been, like that of the silversmiths of New York and Boston, to make spoons and other articles for a retail trade of their own, but to manufacture for the trade. It was his ambition to enter on a large scale into the manufacture of silver goods of every class, whether for ornament and artistic display or combining with these utility for various purposes. To carry out this plan he formed a partnership with

Gorham Thurber, under the firm name of Gorham & Thurber. The purpose of the new firm was principally to make hollow ware. The growth of the business soon made it necessary to have a third party interested in it, and Lewis Dexter, Jr. was admitted in 1852, the firm name becoming Gorham & Co.

George Wilkinson, who had learned his trade as a die cutter in Birmingham, England, was engaged in 1854. He had also given some attention to designing and modeling. He soon developed into an accomplished designer and modeler, evincing rare taste, judgment and fertility, and has had until the present day the superintendence of the designing room. In 1861 about 200 hands were employed. In 1862 Mr. Dexter withdrew from the firm, the name of which remained unchanged. In May, 1863, the Gorham Manufacturing Co. was incorporated, and on Jan. 2, 1865, the charter was accepted. The incorporators were John Gorham, president, and Gorham Thurber, treasurer; J. F. P. Lawton was secretary. The capital stock was fixed at \$300,000, which was increased by act of Legislature in May, 1872, to \$600,000, with a limit of \$1,200,000, which it subsequently rose to. The business during the next ten years after the incorporation steadily increased, the number of hands employed being 450. The shops and rooms for the various purposes of the business had been multiplied until the buildings occupied covered the whole area bounded by North Main, Steeple, Canal and Friend Sts., except a small building, 60 x 40 feet, on the corner of North Main and Friend Sts. At the time of the incorporation the superintendent of the works was Henry E. Lathrop, who died in January, 1871, and was succeeded by George Wilkinson.

In 1860, the Gorham Mfg. Co., in conjunction with G. & S. Owen, erected the building, 3, 5 and 7 Maiden Lane, New York. The company had had an office at 4 Maiden Lane. In 1876 the concern had two stores in New York, at 37 Union Square, and in Bond St. In March, 1877, the Bond St. store was destroyed by fire, and the two stores were consolidated at 37 Union Square. The Chicago store was opened in 1882, under the management of E. W. Prentiss. In May, 1884, the New York branch was removed to the magnificent building at 19th St. and Broadway. In 1885 the company leased the store at 9 Maiden Lane, which they continued till May, 1892 when the downtown branch was removed to the Hays building, 21-23 Maiden Lane. Till 1873 the New York retail trade was supplied with Gorham goods through Tiffany & Co.

In January, 1878, Mr. Gorham retired from the office of president of the company, and was succeeded by Wm. Crins, who retains this office at the present day. In 1876 Edward Holbrook became agent, and in 1889 he became treasurer and general manager. It is but justice to say that to this gentleman the proud position which the



NO. 214 MERRIMAC STREET,  
Newburyport, Mass.

NO. 149-151 STATE STREET,  
Chicago, Ill.



**Towle**  
Manufacturing  
Company,

**SILVERSMITHS.**

◆ ————— No. 1492 Tea Set Ready for Delivery.

1850 ♦ ESTABLISHED ♦ 1894

# PETER L. KRIDER CO.,

618 Chestnut Street,

Philadelphia, Pa.



WE take pleasure in announcing to the Trade our line of ANTIQUE SILVER WARE.



2/3 SIZE



THE accompanying designs are some of the most popular reproductions.



3/4 SIZE.



William E. Wood.

August Weber.



2/4 SIZE.



Gorham Mfg. Co. occupy to-day, is in a great measure due. While the development of the concern up to the last decade partakes almost of the marvelous, the progress during the past 10 years could not have been conceived years ago. Yet this development wonderful as it has been, has not yet reached its limit, for the progress of the Gorham Co. will be limited only by their ingenuity.

In 1887 the land at Elmwood, Providence, on which the present factory stands was bought; in 1890, the factory was completed. Thirteen acres of land represent the site on which the factory is built, of which about six acres are now occupied by the several buildings. The total floor space is 240,703 square feet, equivalent to about five and a half acres. The average force at work is 1,400 people; the works can accommodate 1,800 persons. The officers of the company are: W. H. Crins, president; Geo. H. Robinson, vice-president; Edward Holbrook, treasurer; J. F. P. Lawton, secretary; George Wilkinson, superintendent; Bruce Bonny, New York agent. The capital stock of the company was recently increased \$4,200,000, it all being immediately subscribed for. The honors showered on the company by the judges of awards of the World's Columbian Exposition were but just recognition of the magnificent exhibit which was one of the marvels of the great fair.

#### WOOD & HUGHES.

The father of the old established house of Wood & Hughes, New York, was the same as he who gave birth to the house of Dominick & Haff. In 1833 William Gale formed a partnership with Jacob Wood and Joseph H. Hughes, under the name of Gale, Wood & Hughes. The two latter gentlemen had served their apprenticeship as silversmiths under Mr. Gale. The new firm started business at 116 Fulton St., and manufactured a general line of sterling silverware.

There were several changes in and out of this partnership until 1845, when the firm became Wood & Hughes, which name has been perpetuated until the present day. Jacob Wood and Jasper H. Hughes remained in partnership until 1851, the year of the death of the founder. Then Chas. Wood and Stephen T. Fraprie entered the business, the name of which remained the same. Chas. H. Hughes was admitted into the firm in 1855. He effected several improvements in the mechanical department of the business. Jasper H. Hughes retired in 1856 on account of ill health, the business being continued by the three remaining partners until 1865.

In 1861 the factory was removed to the corner of Cliff and Frankfort Sts., where greater facilities were secured. About the year 1865, Henry Wood and Dixon G. Hughes, the present members of the house, were admitted into the concern. Both had had experience in the office as well as in the factory. The young men subsequently became full partners, and after the death of Charles Wood in 1881, Charles H. Wood in 1883, and Stephen T. Fraprie in Decem-

ber, 1889, they succeeded to the business as equal partners.

The factory remained at Cliff and Frankfort Sts. until 1887, when it was removed to Bank and Hudson Sts. This factory was entirely destroyed by fire in 1891, entailing an irremediable loss of records, models and patterns. The plant was re-established on W. 33d St. Throughout the long career of this house, one salient principle has actuated them, namely, to manufacture a superior line of sterling silverware.

#### F. M. WHITING & CO.

William D. Whiting, born at Attleboro in 1815, was the founder of F. M. Whiting & Co. He learned his trade as a jeweler with Draper & Tift, to whom he was apprenticed at the age of 14 years. In 1840 Mr. Whiting associated himself with Albert C. Tift under the style of Tift & Whiting and with a cash capital of \$500 the new firm entered the business arena. Within two years Tift & Whiting had built for their occupancy a substantial two story shop and in 1847 began the erection of a portion of the present Whiting building by erecting a stone factory 90x40 feet. About six years later another addition of 40 feet was built and at this time Mr. Whiting bought out the interest of his partner, paying for it \$90,000.

Mr. Whiting then established a New York office and began the manufacture of silver combs and hairpins, subsequently adding other silver work, until this branch became very large and resulted in the organization of the Whiting Mfg. Co., with William D. Whiting as president and with a capital of \$150,000 soon afterward increased to \$250,000.

In 1875 a factory was built in New York, where Mr. Whiting conducted the business for five years. He then severed his connection with the Whiting Mfg. Co., and returning to North Attleboro, entered upon the manufacture of silver jewelry and sterling silverware, with his son, F. M. Whiting who had already been in business in that line since 1877, the firm name becoming F. M. Whiting & Co.

#### SIMONS, BRO. & CO.

The house of Simons, Bro. & Co., Philadelphia, Pa., was founded in 1840 by Geo. W. Simons. In that year Mr. Simons, who was born in the Quaker City in 1819, and who had learned the trade of making silver thimbles and pencils, set up in business on his own account on Chestnut St., below Fourth St. About 30 years ago he bought the old Jones Hotel property on Chestnut St., where he remodeled and improved the building in which his sons now continue the business. Mr. Simons died about three years ago.

At his death Mr. Simons left a successful and prosperous business to his sons, John F., Fred. M. and Edwin S. Simons. These gentlemen had been associated with their father in business during his later years, and having inherited the abilities of their progenitor, the ramifications of their estab-

lishment at 618 Chestnut St. have become more and more widespread. John F. Simons has the management of the manufacturing department, which occupies the upper floors of the building. Fred. M. Simons has supervision of all the details of the business outside the factory, while the New York branch of the business, at 20 Maiden Lane, is under the management of Edwin S. Simons. The firm have also a Chicago branch at 90 State St.

The firm produce many exclusive patterns of tea sets and table ware, and do an immense business in comb tops, thimbles, cane and umbrella heads. The factory force numbers about 150 persons.

#### PETER L. KRIDER CO.

Undoubtedly the oldest silversmith in Philadelphia, in number of years of experience at least, is Peter L. Krider, the founder of the concern now known as the Peter L. Krider Co., 618 Chestnut St. This gentleman was born in Philadelphia, in 1821. At ten years of age he went to work on a farm, where he remained until his fourteenth year, when he was apprenticed to John Curry, silversmith, on Chestnut St., whom he served for a period of six years. At the end of this time, his health failing, Mr. Curry retired from business, transferring young Krider's indentures to R. & W. Wilson, silversmiths of the same city. With this firm Mr. Krider worked as journeyman for fifteen months, and then engaged with Obadiah Rich, of Boston, with whom he had made a four years' contract. Two years, before the conclusion of this contract Mr. Rich sold out his establishment to Bracket, Crosby & Brown, Mr. Krider taking charge of the business.

By this time Mr. Krider had become a highly skilled silversmith whose work was admired for its many excellent features. After serving as foreman a short time in the factory of his old employers, R. & W. Wilson, he rented a room at the corner of Dock and Walnut Sts., Philadelphia, and went into business for himself. From these small beginnings, Mr. Krider's business gradually expanded until he was compelled to engage more commodious quarters, which he found in the building at 6th and Market Sts. In 1859 he took into partnership John W. Biddle, and moved to 8th and Jane Sts., where steam power was obtainable. In 1860, the firm, then known as Krider & Biddle, moved to its present location, 618 Chestnut St.

At the breaking out of the rebellion, Mr. Krider went to serve in the army, while Mr. Biddle looked after the business. Five or six years after the close of the war the latter gentleman retired, Mr. Krider continuing the business. Mr. Krider about five years ago sold his business to August Weber, who had served him faithfully as clerk, retaining a small interest in the business. Mr. Weber has since taken a partner, W. E. Wood, into the business, which is now carried on as the P. L. Krider Co. This house has perhaps the largest medal plant in the country, and has produced many famous medals.



## JOS. SEYMOUR, SONS &amp; CO

In the city of Syracuse, N. Y., stands an old fashioned building on the face of which, though almost obscured by time, can be read the sign "Joseph Seymour." It is a silverware factory, and here for nearly 40 years the manufacture of flatware has been carried on by the late Joseph Seymour and his sons succeeding him. Joseph Seymour was born near Albany, N. Y., in 1815. He went to New York to apprentice himself to a leading silversmith of that city at the customary age. He became associated with Willard & Hawley in the establishment of a silverware factory in Syracuse, of which he subsequently became the sole proprietor. His sons, Joseph, Jr. and E. G., and George F. Comstock, Jr., were admitted to partnership in the course of time and for some years past the firm name has been Joseph Seymour, Sons & Co.

Mr. Seymour, it is said, was the first man in the country to make a society mark or emblem, having made a number for a lodge in Utica, N. Y., long before the war. This branch of business he followed for some time successfully in connection with the production of flatware. Through the purchase of the retail business of D. Valentine, his responsibilities were largely increased but he still continued to devote most of his time to the silverware factory until his death in 1887. The factory is now in charge of Chas. H. Seymour, who was for many years under his father's tuition. The firm have always done a conservative business, and have found a ready sale for their product.

## J. B. &amp; S. M. KNOWLES CO.

One of the oldest concerns engaged in the manufacture of sterling silver flatware is the J. B. & S. M. Knowles Co., Providence, R. I. In 1852 Joseph B. Knowles, son of Ex-Mayor Edward P. Knowles, of Providence, formed a partnership with Henry L. Webster, of Boston, an experienced manufacturer, who had been associated with Jabez Gorham some years before, under the firm name of Webster & Knowles, for the manufacture of sterling silverware. Young Knowles had already mastered the jewelry trade. The firm applied themselves almost entirely to the production of tableware in all its branches, of which they make a specialty to this day.

The first shop was located on Meeting St., with another young firm, Farrington & Salisbury, as near neighbors. Webster & Knowles soon bought out and engaged the members of Farrington & Salisbury as workmen. The business grew steadily and the need of larger quarters compelled them to move to 137 S. Main St. in 1853, and again to larger quarters in 1856 on Middle St., in the Mathewson Allen building. New lines were added, improved facilities acquired, and in 1859 Samuel J. Ladd was admitted to the firm.

In 1864 Mr. Webster withdrew from the firm and his death occurred in 1865. The firm name was changed to Knowles & Ladd, and in 1868 they moved to their present quarters, the second floor of 95 Pine St. As

early as 1864, desiring closer touch with metropolitan and outside trade, a New York office was established at 20 Maiden Lane, in charge of Stephen M. Knowles, a younger brother of Joseph B. Knowles. Ten years later this was removed to 8 Liberty Place, the firm soon returning, however, to the ground floor of No. 20. For the past four years their New York office has been located at 860 Broadway, Silversmiths' Hall.

In 1875 Mr. Ladd retired and Stephen M. Knowles was admitted, the firm name becoming J. B. & S. M. Knowles. Joseph B. Knowles, who had charge of the factory from the start, was a thorough mechanic and a man of indomitable perseverance and industry. Close application to business undermined his constitution, and on Jan. 4, 1891, he died, universally esteemed by his employes and his fellow citizens. The business was shortly afterward incorporated under the name of the J. B. & S. M. Knowles Co., with Stephen M. Knowles president, and William C. Burwell, a son-in-law of the late Joseph B. Knowles, as treasurer.

Besides various patterns in staple flat ware, they have devoted much attention to the production of fancy flat ware and hold a deservedly high place in this line. In etched work they justly claim superiority, and during the souvenir spoon craze they were unable to meet the demands upon them for this class of work.

The company are now anticipating moving into a new building in process of construction on Sabin St., where they will occupy two floors and be better able, with increased facilities, to meet the larger demand for their goods.

## R. WALLACE &amp; SONS MFG. CO.

One of the most noted factories in Connecticut which is devoted to the manufacture of silverware, and one which has in no small degree contributed to the development of the industry, is the R. Wallace & Sons Mfg. Co., Wallingford. This immense enterprise embraces a number of large factories, and employs over 500 people. It was established by Robert Wallace in 1855, under the title of R. Wallace & Co., Samuel Simpson being one of the firm.

Robert Wallace when a young man, in the year 1835, secured from a foreigner the receipt for making German or nickel silver. He produced some of the metal and he had it manufactured into spoons at a mill in Waterbury. After its practicability had been thoroughly tested, he manufactured the metal on a small scale, and in 1855 established the factory out of which the present concern has grown. He is believed to have been the first person to manufacture German silver. In September, 1865, the firm changed its name to Wallace, Simpson & Co., and on June 17, 1871, it was incorporated under the title of the R. Wallace & Sons Mfg. Co. Beginning with table wares, one branch after another has been added until the company now make all kinds of solid silver, nickel silver and silver plated goods. The capital stock in-

vested in the company is about \$700,000, and the officers of the corporation since the death of Robert Wallace, which occurred Jan. 1, 1892, are: President, F. A. Wallace; secretary, Henry L. Wallace; treasurer, W. J. Leavenworth.

Robert Wallace was one of the old school of men. Up to the time of his last sickness he had his bench in the factory, where he was always to be found apron on and hard at work, and ever ready to give information to any who desired it. Like Mackay, the bonanza millionaire, he thought there was "too d— much quarterdeck" in the business offices, and it was rare that he was seen there; he was always at his little work bench with the men in the factory.

The main factory building is devoted exclusively to the manufacture of solid silver table ware. The manufacturing plant contains all the latest improvements in the way of machinery and appliances. All kinds of spoons imaginable are manufactured, from the plain table spoon to the most elaborate souvenir spoon.

The company maintain stores at 3 Park Place, New York, and at 86 Wabash Ave., Chicago. The New York branch is conducted by John W. Sisson, and the Chicago store is in the hands of Geo. M. Wallace.

## WM. B. DURGIN.

Wm. B. Durgin, Concord, N. H., is the oldest manufacturing silversmith now engaged in business. He was born in Camp-ton Village, N. H., under the shadow of the White Mountains, in 1833. As a boy his mind turned toward mechanics, and at 16 years of age he took a position in the silverware manufactory of Newell Harding & Co., Boston. He was an apt apprentice, and as he progressed in his trade his employers recognized him as one of their most promising workmen. Possessed of a remarkably accurate eye, and of all the keen instincts of a born mechanic, he was never satisfied with anything but perfect results. Careless work in others has always been absolutely painful to him, and for years after gaining a position of independence as an established manufacturer, he found his greatest enjoyment at the bench, instructing and drilling his men and inspecting their work to the minutest detail.

After the apprentice had faithfully served his time and become a journeyman, his ambition to take a place in the world would not allow him to stay at the bench working for wages. He had saved \$200, and with this poor pittance and a little more advanced by his father, he rented one small room in Concord at \$75 a year, and with a few necessary tools the young mechanic began making plain spoons. The satisfaction his work gave was evinced by its steadily increasing popularity, and larger quarters became necessary. Mr. Durgin then built a small ten-foot wooden shop on the site of his present commodious establishment. As business outgrew his quarters he dared dream of owning an equipped factory. He bought the land he had leased and more lying contiguous, negotiated a loan at one of the



THE  
**ARGO.**

**SOLID SILVER**  
EXCLUSIVELY.



**J. B. & S. M. Knowles Co.**

SALESROOMS:  
860 Broadway, Union Square,  
NEW YORK.

Factory and Main Office:  
**PROVIDENCE, R. I.**



We are Equipped to furnish a complete line of Argo Fancy Pieces.

# GEO. W. SHIEBLER Co.



TRADE MARK.

## SILVERSMITHS.

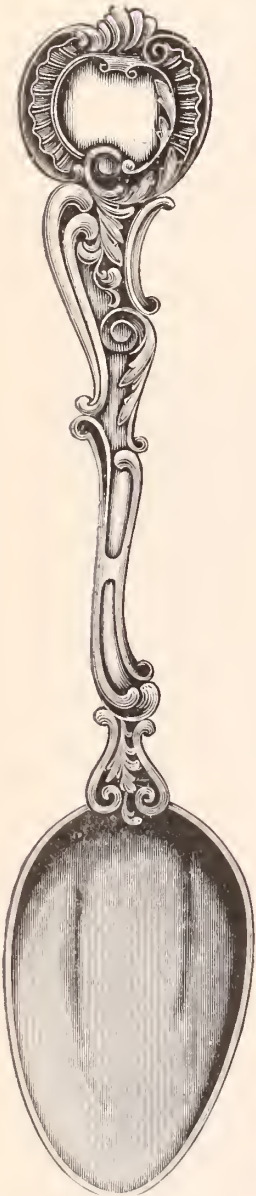

ROCOCCO.



LOUVRE.

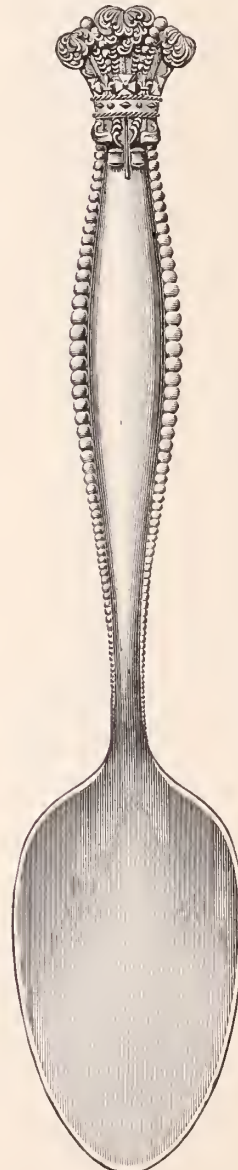

SANDRINGHAM.



FLORA.



FLORA.

The "Flora"

COMPRISES 12 DIFFERENT DESIGNS.

No. 179 BROADWAY,

=

=

NEW YORK.



banks, and built a four-story brick building, and fitted a part of the first floor and basement for manufacturing.

"Durgin's spoons" had become favorably known throughout New England. Figured patterns were demanded, and Mr. Durgin followed a live policy and brought them out. Enlargement followed as a natural sequence, and one by one the different tenants of the brick building were asked to give place to men and machinery. In 1880 Mr. Durgin's only son, George F. Durgin, became an active factor in the business, and the senior, who had begun to feel the great strain of unremittent labor, settled back a little to enjoy a well earned rest. The young man had already acquired much practical knowledge of the business. Soon the making of hollow ware was begun. To-day the factory turns out a large line of hollow ware and novelties.

Two years ago it was found necessary to add another story to their factory, and a year ago the establishment was further increased by acquiring land in the rear and the building of a considerable addition. The house of W. B. Durgin is one of the most progressive in the trade. A familiar instance of the enterprise of the Durgins and their alertness in following the public taste was furnished by the souvenir spoon fad. They were the first to see the extent of the demand that was destined to spring up for these pretty little trifles.

#### FESSENDEN & CO.

In 1859 William B. Fessenden, who was engaged in the jobbing jewelry business in Boston, Mass., decided to establish a silverware factory in Providence, as an auxiliary. He accordingly took into partnership his son, Thomas F., and started as Wm. B. Fessenden & Co., in the manufacture of fancy flat and staple hollow wares. In 1860 Mr. Fessenden abandoned his Boston jobbing business and, selling out his Providence interests to his son, retired. In 1864 he died. T. F. Fessenden, feeling the need of a partner, admitted Giles Manchester, who remained in charge of the manufacturing department until his death in 1889.

In 1876 S. H. Manchester, a brother of Giles, took a small interest, which, on the death of the latter became a partnership interest, and he assumed the management of the shop. Since 1860 the business has been carried on under the name Fessenden & Co., 100 Friendship St. Their line consists of fancy spoons and staples, such as napkin rings, cups, etc., sold exclusively to the jobbing trade. Wm. B. Fessenden was at one time a member of the jewelry and silverware firm of Whiting, Fessenden & Cowan, North Attleboro, the predecessors of the Whiting Mfg. Co.

#### J. F. FRADLEY & CO.

In 1868, J. F. Fradley who had completed his apprenticeship as chaser in the silverware factory of Wood & Hughes, opened a small workshop in the Gilsey Building, corner of Broadway and Cortlandt St., New York, and began doing chasing for the trade. He

soon had a staff of between 25 and 30 chasers in his employ.

In 1870 Mr. Fradley decided that if his work was so attractive for others it would be more so on goods manufactured by himself and he accordingly opened a small factory at 68 Nassau St., for the production of gold-headed canes which at that time were very popular.

The venture proved a success from the start, and in 1873 he moved his office and factory to 18 John St., and added all kinds of silver novelties to his productions. The next move a few years later was to 21 John St. Subsequently the office was moved to 23 John St., and the factory to the southwest corner of Pearl and Frankfort Sts., where it is now located. The whole top floor is occupied by the firm, together with the basement.

The silverware produced by the firm shows the result of artistic workmanship, and to secure the latest novelties, Mr. Fradley takes annual trips to Europe. The office of the firm was moved to Silversmiths' Hall, Union Square, May, 1891. Some years ago Mr. Fradley admitted into partnership D. P. Mygatt, a young man who had been in his employ several years, and subsequently F. M. Matthews, John Blackwell and George Fradley were admitted.

#### GEO. W. SHIEBLER CO.

The adaptability of silver to the manufacture of wares that combine the essentials of beauty with the elements of utility is evidenced by the practically unlimited range of articles which are variously known as small wares, trinkets, novelties, etc., that are produced. The house that has been foremost in this line of activity is the George W. Shiebler Co., New York.

George W. Shiebler entered the employ of Jahne, Smith & Co., 170 Broadway, New York, in 1867, as traveling salesman. The firm then manufactured gold chains. Mr. Shiebler remained with them until the death of both Mr. Jahne and Mr. Smith, in the year 1870 or 1871, when the firm was succeeded by Hodenpyl, Tunison & Shiebler, who continued the business as theretofore. The firm, like numerous others, was affected by the stringent times that followed the panic of '73. Mr. Shiebler about a year later purchased the business of Coles & Reynolds, manufacturers of silver spoons, with a factory at 6 Liberty Place.

Mr. Shiebler commenced business on March 4, 1876, with a force of five men. A few months later he bought out the business of John Polhemus, an old and recognized silversmith, whose plant was located at Centre and Howard Sts. He merged this plant with his own, and continued thus for a short time, when he purchased the factory of M. Morgan, who had succeeded Albert Coles, at 6 Liberty Place. This plant he also merged with the others, on the fifth floor of 6 Liberty Place. Mr. Shiebler's facilities were now quite extensive, and his business was rapidly progressing.

A few years subsequently he moved his showrooms to 8 Liberty Place and his factory to a building at York and Washington Sts., Brooklyn, N. Y. At this time Mr. Shiebler's factory gave employment to 50 to 60 people. Anon, the space becoming too crowded, Mr. Shiebler purchased property at St. Mark's and Underhill Aves., Brooklyn, and erected a finely equipped factory building, of which the firm occupy at the present time three spacious floors, giving employment to 160 to 170 individuals. On Jan. 1, 1892, the firm incorporated as the George W. Shiebler Co., with a capital stock of \$300,000. George W. Shiebler is president and Wm. F. Shiebler, treasurer of the company.

Mr. Shiebler at the beginning made only spoons and forks, but the product gradually increased until the firm produced the largest line of novelties in silver extant at the time. One of the reasons of the success of the house has been the introduction of novel ideas never before attempted, one of the most successful innovations being the curio medallion work, which looked as though it had been unearthed at Pompeii and Herculæum. Another such novel line was tinted leaf work, consisting of silver formed into leaves and tinted in all the rich colors of Autumn. In addition to their unique artistic lines of small wares, the company, which now have an extensive store at 179 Broadway, opened Aug. 1, 1892, manufacture a general line of silverware of the highest character.

#### HOWARD STERLING CO.

One of the youngest silversmithing firms in Providence though among the foremost in the high standard of its products, is the Howard Sterling Co. Within the brief period of less than eight years this concern has developed by indomitable energy, enterprise and business sagacity from comparatively small beginnings into magnificent proportions. The firm started in 1873 as H. Howard & Co., in a room used as a manufactory and office, in the Dyer Street Land Co.'s building, and employed 15 operatives. At the outset they devoted themselves to the manufacture of plated jewelry. The business rapidly increased and necessitated the enlargement of the manufactory and the number of employes was augmented to 175. In July, 1886, a department was established for the manufacture of wares in sterling silver. This department was conducted under the title of The Sterling Co.

During the Fall of 1888 the firm discovered that their combined industries had outgrown their limited accommodations, and on Jan. 1, 1889, they removed to the Enterprise and Allen Green buildings on Eddy, Fountain and Worcester Sts. The third floors of both these buildings and the fourth floor of the Allen Green building were converted into a model factory. In January, 1891, the concern was granted an act of incorporation as the Howard & Son Co., and continued under that title until December, 1891, when they



disposed of the plated goods branch of the business to another firm, and at the same time the name of the corporation was altered to that of Howard Sterling Co. From that time the entire attention of the concern has been devoted to the development of the silver department. The concern has ever exercised the best judgment and discrimination in the employment of none but competent and devoted assistants. The officers of the company at present are: Hiram Howard, president; Stephen C. Howard, treasurer; W. Edward Fiske, secretary; Charles C. Wientge, superintendent. The New York salesrooms are at 860 Broadway, Silversmiths' Hall.

#### THE TOWLE MFG. CO.

The Towle Mfg. Co., Newburyport, Mass., are an indirect outgrowth of efforts of individuals and co-operative industries established as early as the seventeenth century. In the vicinity of Newburyport, the art of the silversmith has been practiced for over 200 years, the culmination of these efforts being found in the factory of the Towle Mfg. Co.

The pioneer colonial silversmith was William Moulton, 2<sup>d</sup>, whose first silver shoe buckles appeared about 1690. The first goldsmith in New England whose successors in a direct line have continued to the present time was Joseph Moulton, son of William Moulton, 2<sup>d</sup>. From the rude "Blacksmith and Whitesmith Shop" of the Moultons in 1690 has been evolved one of the most complete silverware factories in the world.

Seeking for the origin of the Towle Mfg. Co., we find other names prominent among the early Newburyport silversmiths. Jacob Perkins, born in 1766, assumed the management of the business of his deceased master, Davis, at the age of 15 years. He afterward removed to London. Bradbury & Bro., manufacturing silversmiths, thrived about the year 1800.

The Towle Mfg. Co. incorporated in 1880 with a capital of \$20,000. Their growth has been continuous and remarkable, until today they rank among the first houses in America engaged in the manufacture of silverware. Their capital has been doubled and doubled again until now the stock is \$372,000. The wares manufactured are mainly sterling silver and embrace everything known as table flatware. The principal building of the company is a handsome brick structure, 184 feet in length by 40 feet in depth and has four stories. This building, with the wings and smaller buildings, gives a floor space of about 35,000 square feet.

The large business done through their Chicago branch is the result of the personal abilities of J. A. Todd, and of the quality of the productions. The officers of the corporation are: President, Eben Sumner; treasurer, Wm. H. Swasey; vice-president and manager, L. D. Cole.

#### FRANK W. SMITH.

The town of Gardner, Mass., embraces among its industries a thriving silverware manufactory, of which Frank W. Smith is

the proprietor. Mr. Smith commenced business in Gardner about eight years ago, having had a previous experience of nearly 20 years in the silverware line. He constructed a substantial brick building 40x60 feet, three stories in height, put in the latest improved machinery, and secured the services of some of the best artisans in the country.

Mr. Smith's factory turned out its full share of designs in souvenir spoons, adding to its reputation as a producer of artistic silverware. The aim of the manufacturer has been to produce original designs unsurpassed in finish. His success has been such that he has found it necessary to enlarge his factory, giving him a building 40x120 feet, three stories in height.

#### ALVIN MFG. CO.

The Alvin Mfg. Co. in their career have carved out a plan of business of their own, and have attained marked success in their several unique lines of silver work. The company incorporated on Aug. 17, 1887, for the manufacture of sterling silverware and novelties. Wm. A. Jamouneau is president and secretary of the company, and Henry L. Leibe is treasurer. Both are practical mechanics and thoroughly posted in all the technical processes involved in the manufacture of silverware. The business of the company, which took a factory in the large building at 24 Boudinot St., Newark, N. J., increased to such an extent that it became necessary for them to procure more capacious quarters in which to carry on the industry. Their recently erected works are situated near the village of Irvington, N. J. The main building is an immense brick structure two stories high with basement, 120 feet long by 40 feet wide.

Doubtless the most novel and at the same time artistic work turned out by this company is that known as electro-deposit goods. This class of work was invented and brought to a state of commercial success by this firm. An important branch of this special process is the coating of handles for umbrellas and canes. This company have been among the most extensive producers of souvenir spoons.

The company have offices at 860 Broadway, Silversmiths' Hall, New York.

#### REED & BARTON.

The old established house of Reed & Barton, Taunton, Mass., have for years enjoyed a world-wide reputation as manufacturers of nickel and silver plated wares, and when some four years ago they announced their intention of adding a complete new line of sterling silver, something out of the ordinary was expected of them. Abundance of capital, the pride of fifty years of successful effort and a determination to lead and not to follow, prompted them to select a field comparatively untried in this country—that of enameling on silver.

Experts from abroad had to be engaged to train the large force of employes in the secrets and niceties of the art. Some branches of the work which they undertook

were quite new as a manufactured product, the art having been pursued abroad by individual artists, whose field was necessarily very limited, and who preserved the secrets of their craft jealously guarded from the curious eye. To-day the American public can feast their eyes upon the hand-somest line of hand painted enameled silver goods made anywhere in the world. Another and very beautiful class of work which Reed & Barton are now producing with much success, consists of a combination of enamel with gold of different colors. Although they have been only a few years engaged in the manufacture of sterling silver, they have produced beside this superb enamel work, a number of very fine sample patterns in flat ware.

Reed & Barton have for some years been a corporation, of which the present officers are: Henry G. Reed, president; Geo. Braybrooke, treasurer; and F. L. Fish, secretary. Mr. Reed has been connected with the business for over sixty years, having served his apprenticeship with the old firm of Babbitt & Crossman, the predecessors of Reed & Barton. The name of Reed & Barton was adopted in 1837 and has since been retained.

#### LUDWIG, REDLICH & CO.

Ludwig, Redlich & Co. organized in 1890 and a small office and factory were opened at 247 Centre St., New York, with a force of eight men. Adolph Ludwig had for nine years previous been an expert designer of silverware for Geo. W. Shiebler, now the Geo. W. Shiebler Co. A. Alec Redlich, his partner, had spent the greater portion of his life in the diamond business, and had an extended acquaintance in the retail trade. A few months after the firm started an office was opened at 45 Maiden Lane. The following May the office was removed to Silversmiths' Hall, Union Square. A month later the factory was moved from Centre St. to 351 and 353 Jay St., Brooklyn, where 6,250 square feet of space are now occupied by the machinery of the concern, and in the busy season about 100 hands are employed.

The part played by Tiffany & Co. in the development of the silverware industry in America is dwelt upon in the history of this house which appears in another part of this number of THE CIRCULAR. In the compass of such an article as this it is practically an impossibility to apportion out the proper meed of recognition to all firms and individuals who have acted parts in the development of the industry. It is to be hoped that the persons whose names are omitted will look at the matter in this light. Besides the firms whose histories are set forth in the foregoing are Samuel Kirk & Son, Baltimore, Md.; Myrick, Roller & Holbrook, Davis & Galt and Hamilton & Diesinger, Philadelphia, Pa.; The Duhme Co., Cincinnati, O.; Wendell Mfg. Co., Chicago, Ill.; and Wilcox & Everson, New York, and many individual workers to whom some credit is due for their achievements in the art of silversmithing.



LEADING PATTERNS IN 

# HIGHEST GRADE

ELECTRO SILVER PLATE.

---



SHELL.

MONARCH.

FRONT.

KING.

BACK.

MAJESTIC.



MAJESTIC INDIVIDUAL SALAD FORK.

MANUFACTURED BY

The Rogers & Hamilton Co.,  
 WATERBURY, CONN.

# Stern Bros. & Co.,

CUTTERS AND

IMPORTERS OF

# DIAMONDS,

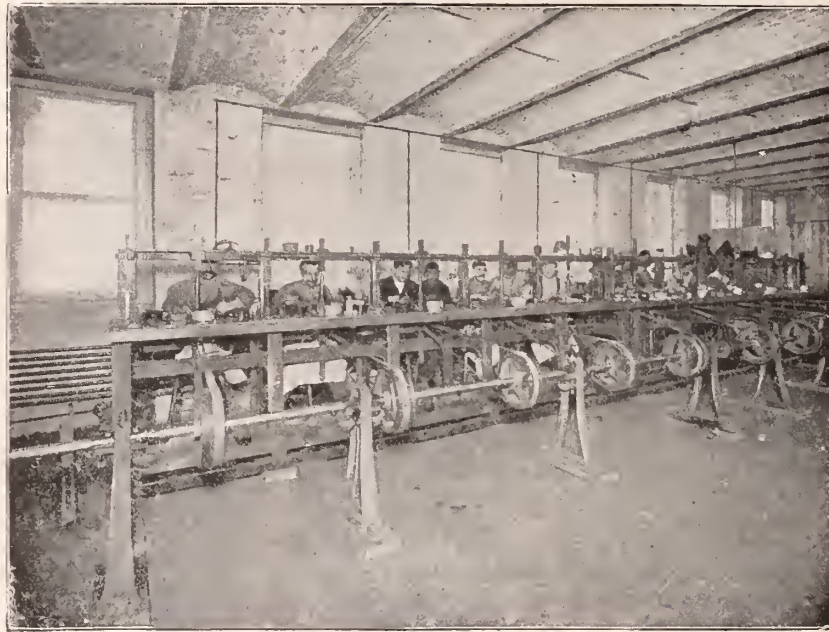

GENERAL VIEW OF EAST WING OF DIAMOND CUTTING WORKS, SHOWING  
POLISHING MILLS IN OPERATION.

30 MAIDEN LANE,

NEW YORK.

DIAMOND CUTTING WORKS,

2 TULP STRAAT,

29-31 GOLD STREET, NEW YORK.

AMSTERDAM.



## THE DIAMOND CUTTING INDUSTRY IN AMERICA.

IN ancient writings there is but little mention of diamonds, the more positive blues and reds of the other gems appearing to have had a greater fascination for the eye than the mediocre brilliancy of an uncut diamond. The European, to whom is usually accorded the honor of being the first cutter and polisher of diamonds is Louis de Berquem, a native of Bruges. It is a matter of history that de Berquem, in 1465, worked at a polishing wheel, said to be of his own invention, and cut facets upon diamonds and other gems placed into his hands. In India and in China the cutting and polishing of gems was an industry practiced by the native artisans long before that time, and we find in an inventory of French royal jewels sundry "cut diamonds" as early as 1360.

The process of cutting and polishing a diamond is full of interest. Finally wrested from the bosom of Mother Earth and divested of its hard clay envelope, the irregular crystals, technically known as "rough," find a market first in London. Thence the major portion goes to Amsterdam, a city which is the centre of the diamond cutting and polishing industry in the world, employing in that business over 10,000 workmen.

The primary operation is the cleaving, which nearly all stones undergo in order to make them of the greatest commercial value. An expert examines the stone in the most thorough manner, noting the formation and plan of the piece of rough. His judgment and experience tell him the number of pieces into which the stone can best be cleft, and having completed his examination, the rough diamond firmly imbedded in cement, has scratched upon its faces, by means of another diamond, a line or lines along which it is proposed to make the contemplated division. With a sharper pointed diamond the first line is again gone over, and the cut made deeper, until it is considered safe to deliver the final blow which will separate the stone. Everything being in readiness, a fine steel blade is placed upon the scratch, and with a sharp quick tap upon the blade, the experienced cleaver finds his rough neatly split in twain.

In its next stage, the cleft stone undergoes the cutting and begins to assume its general form as either a "brilliant" or a "rose." The old method, still in use in many European shops, is to rub together two rough diamonds, each embedded in cement at the end of a suitably shaped handle. In this country, however, diamond cutters generally use a machine or lathe in which the stone in process of cutting is securely held in a rapidly revolving chuck, while another rough diamond similarly fastened in an adjustable chuck and guided by the workman,

is brought in contact with it. By attrition, the stone gradually assumes shape and outline and is soon brought to a state in which it is ready for the polisher.

This workman, from whose hands the stone finally comes as the bright and sparkling diamond so universally admired, must bring judgment and experience into play in the final stage. He must determine the most advantageous method of polishing the stone, and if it have any defects, how best they may be remedied or minimized. Having determined on his first facets, the stone is imbedded in molten composition metal contained in a conically shaped hollow at the end of an iron arm having at the further end two small peg like projections or feet. The diamond embedded in metal and exposing only the small portion upon which



THE CLEAVER AT WORK.

the facet is to appear, forms the third "leg" of the iron when it is finally ready for the polishing. This is done on a disc or wheel of steel, about a foot in diameter and revolving at a very high rate of speed, usually about two thousand revolutions per minute.

On this disc, mixed with oil, is placed the diamond dust resulting from the cleaving and cutting, and when in motion the iron holding the diamond is fitted into its proper place at the bench in such a manner that the metal embedded diamonds rests upon the revolving disc. A polisher may have from one to half a dozen stones on the wheel at the same time, and as he must constantly watch the stones to note how the cutting progresses, his work is by no means easy. In the larger shops he has an assistant, termed a setter, whose duty it is to

remove the stone from its metal case when the desired facet has been cut, and reset it again in proper position for the next facet. As only three facets can be cut in one position the stone must be reset again and again before it acquires the numerous angles, which, thanks to refraction, give the diamond its brilliancy, and make it when, in a completed state, it finally leaves the polisher's hands, the peer of gems.

The pioneer diamond cutter in this country was Henry D. Morse, of Boston, Mass., who in 1859 first showed what could be done by mathematical accuracy in the cutting and polishing of diamonds. Henry D. Morse in early life learned the engraver's art and subsequently became a jeweler. Shortly after the great yields of the South African diamond fields began to attract the attention of the trade in 1861 B. S. Pray, of Boston, at that time engaged in the African diamond trade, brought to this country a parcel of rough with the intention of seeing what Mr. Morse could do in the way of cutting. The two men associated themselves in business and in a short time, the industry of diamond cutting was an established fact in this country. The Morse Diamond Cutting Co. was the style of the firm, and American stone dealers watched the outcome of the undertaking with much interest.

Dutch workmen were employed at first, working under Mr. Morse's supervision. Conformably with their long established custom the workers maintained secrecy with respect to their art, but Mr. Morse, already familiar with the work took pains to familiarize himself with all details, which he communicated to apprentices in a shop established in the suburbs of Boston without the knowledge of the Dutch workmen. When the latter finally struck, Mr. Morse was ready for them and his American hands took the places of the Amsterdam cutters at once.

In 1869 Mr. Morse had delivered to him an American diamond, found near Richmond, Va., and by adroit manipulation and due regard to lights and geometrical relations, produced from the rough stone a gem which permanently established his reputation as a cutter and polisher. The firm of Crosby, Morse & Foss, which succeeded the Morse Diamond Cutting Co., was dissolved in 1875, Mr. Morse going into business on his own account as a cutter and dealer in diamonds. In 1887 Mr. Morse again associated himself with one of his old partners, under the style of Henry D. Morse & Charles D. Foss. Mr. Morse died on Jan. 2, 1888, experiencing, undoubtedly, a feeling of satisfaction in seeing the art introduced by him develop, there being about a dozen cutting shops in this country at the time of his death.

ESTABLISHED 1876

*J. B. Humphrey*

**Diamond Cutter**

IMPORTER OF DIAMONDS  
AND OTHER GEMS

383 Washington St.  
Boston, Mass.

Special Attention  
given to Matching  
Recutting and Repairing





Prior to the days of the Morse Diamond Cutting Co., the usual shape of the cut diamond was what is termed in the trade cushion cut. Mr. Morse was the first to introduce the circular shaped stone of to-day which he did soon after he opened his cutting shop. He did this, too, at a time when he himself had on hand quite a large stock of the cushion cut stones which had to be recut to meet the popular demand for circular stones, or be sold at a sacrifice. How popular the circular shape, in which nearly all diamonds are now polished, eventually became, may be imagined when one considers how rarely a cushion or square cut stone is seen to-day.

Mr. Morse was also the inventor of a cutting machine for shaping rough diamonds which greatly facilitated that previously tedious operation. He introduced cutting by gauge, making all facets and angles mathematically correct and really showing delighted buyers for the first time the brilliant possibilities of a properly cut diamond.

Shortly after Mr. Morse's death the diamond cutting business of the firm of H. D. Morse and C. D. Foss was purchased by J. B. Humphrey, who being himself in business as a practical cutter and polisher, since 1876, had already produced work which elicited much admiration. One boy and himself composed Mr. Humphrey's shop complement when he started, but this staff had been augmented considerably when in 1890 he moved into the old Morse shop at 383 Washington St. where he to-day turns out work, flawless, accurate and known for its beauty over the entire country. Every stone in Mr. Humphrey's shop is cut by gauge and every facet polished with the grain. Hence, on a finished stone from his hands one finds nowhere on any one facet that slight roughness which occasionally appears on some of the facets of what would be called perfect stones. To-day Mr. Humphrey employs over a dozen men and challenges the finest polishers in Europe to produce stones equal to his.

In New York there are to-day in operation about fourteen shops in which diamonds are cut and polished. The largest of these, a shop where about one half of the employed workers in this country are employed, is that of Stern Bros. & Co., Gold St. In this establishment, which is the only one in the country conducted on the European plan of buying large parcels of rough which are cut under the direct supervision of the firm, a parcel of rough is kept intact throughout the entire process, being returned as cut diamonds, greatly reduced in weight but still constituting the original parcel. At present Stern Bros. & Co. have about 50 men constantly employed at cutting and polishing diamonds, and so satisfactory has been the result of their venture into the cutting field that it will be but a short time

when one hundred men will be found at work in the commodious Gold St. shop. Improved machinery both for cutting and polishing enables the firm to produce cut stones which find a ready market here, where it is known the people insist on much finer workmanship than would satisfy the European purchaser.

Other cutting establishments in New York, the center of the polishing industry in this country, are those of Randel, Baremore & Billings, Tiffany & Co., Chas. G. Browne, L. Tannenbaum & Co., D. De Sola Mendes & Co., M. D. Ferro, R. Ramsgate, J. Weiner, H. A. Groen & Bro., Norden & Co., H. Levy, and three or four others employing but few men. There is some cutting done in Chicago by the Stein & Elbogen Co. Competent judges place the number of men



THE DIAMOND POLISHER AT WORK.

in this country engaged in the cutting and polishing of diamonds at less than 150.

As has already been stated, American buyers demand a much better quality of work than would satisfy the ordinary buyer in the European marts. Those, however, who have seen a mediocre diamond transformed into a snapping, blazing gem, full of fire, simply by being re-cut with a proper regard for the accuracy of the facets, cannot blame the American public for its choice. Owing its brilliancy to refraction, a pure white stone, badly cut, may not possess one-half the beauty of another of not nearly as good color, but properly cut.

Very few diamonds have been found in the United States. California, Wisconsin, North Carolina and Georgia have all been the scenes of incidental finds, and while the African diamonds are found in a hard blue

clay, American diamonds have been found in debris of crystalline rocks among gravel and earth. No systematic attempt at diamond mining has ever been made here. The largest American stone ever found was picked up near Richmond, Va.; it weighed about 25 karats in the rough, and was cut into a stone of about one half that weight.

Our imports of rough diamonds for the last 20 years are given below:

YEAR ENDING	VALUE.
June 30, 1873.....	\$176,426
" " 1874.....	144,629
" " 1875.....	211,920
" " 1876.....	186,404
" " 1877.....	78,033
" " 1878.....	63,270
" " 1879.....	104,158
" " 1880.....	129,207
" " 1881.....	233,596
" " 1882.....	449,513
" " 1883.....	443,996
" " 1884.....	367,816
" " 1885.....	371,679
" " 1886.....	302,822
" " 1887.....	262,357
" " 1888.....	322,356
June 30, 1889.....	250,187
" " 1890.....	513,611
" " 1891.....	804,626
" " 1892.....	1,109,429
" " 1893.....	1,066,586

A certain proportion of this rough is of course used in the arts, for glazier's points, etc. The increase in imports since 1890 is notable.

An expert report in 1890 placed the number of men engaged in cutting and polishing diamonds in the United States at that time at 167 men and 69 boys, and the number of shops at 19. The men worked an average of 234 days in the year and earned an average of \$3.53 per day. The boys averaged 216 days, and earned 65 cents per day. Total wages paid, \$148,114 for gems which were cut from 54,344 karats of rough, and were valued at \$1,006,716.

The average wages paid in New York to-day are \$2.00 per karat less bench expenses. In Boston, where

special accuracy is required of the cutters, the price paid workmen per karat is higher. Good European workmen also receive an equivalent of about \$2.00 per karat in the shops there, while their bench expenses are less than they are in this country. When one also takes into consideration the fact that better work is required here for the same wages it will be seen that there is small inducement for Amsterdam cutters to emigrate. If, in addition to all this, cutters are to pay a duty of 15 per cent. on rough, as is proposed in the Wilson bill, the future of the American diamond cutting industry is extremely uncertain.

Dr. Knapp, of New York, an authority on the subject, is reported as saying that in nine cases out of ten epileptic fits can be cured by the use of spectacles.

JEWELRY CASES,  
TRAYS.

Jewelers' Findings,  
Chamois Bags.

# S. & A. BORGZINNER,

82 & 84 Nassau Street, New York.

SILVERWARE—CASES.

PAPER BOXES—CARDS.

## R., L. & M. Friedlander,



IMPORTERS OF  
DIAMONDS.

WHOLESALE  
JEWELERS.

JOBBERS IN  
American Watches.

Tools, Materials, and Optical Goods.

Send for Catalogue.

65 & 67 Nassau Street, New York.

## F. W. GESSWEIN,

39 JOHN STREET,

NEW YORK.

### ENGRAVERS' REFLECTORS

FOR OIL OR GAS, SINGLE OR DOUBLE.

The Glass Reflecting Globe magnifies and concentrates the light, and can be adjusted to cast it on any desired point.

... Circulars and Price Lists on Application ...

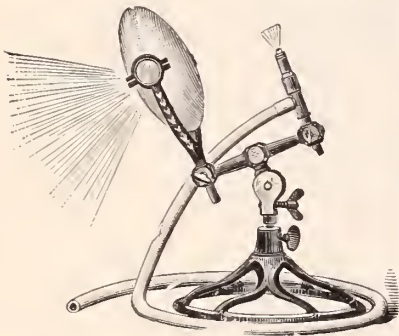

VACHERON & CONSTANTIN,  
GENEVA, SWITZERLAND.

FINEST QUALITY OF WATCH MOVEMENTS, FITTING  
ALL SIZES OF AMERICAN CASES.



\* V. & C. \*

CHAS. LEO ABRY,

Agent for the United States and Canada.

41 and 43 Maiden Lane, - - - NEW YORK.



# AUTOMATIC WATCHES

IN GOLD, SILVER and NICKEL  
CASES, HUNTING and  
OPENED-FACED,

At Half the Cost  
of Importation

Headquarters for

## Waltham Watches

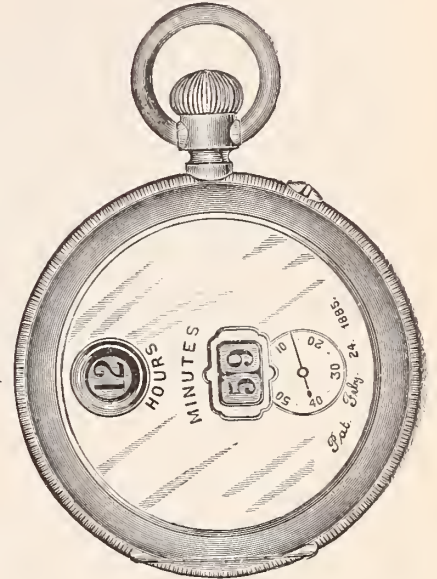

Diamonds

Watches

Silverware

Optical Goods

Tools and Materials

..... and .....

EVERYTHING ELSE NEEDED BY JEWELERS.

DAVID F. CONOVER.

B. FRANK WILLIAMS.

### David F. Conover & Co.

Chestnut and Seventh Sts.,

PHILADELPHIA.

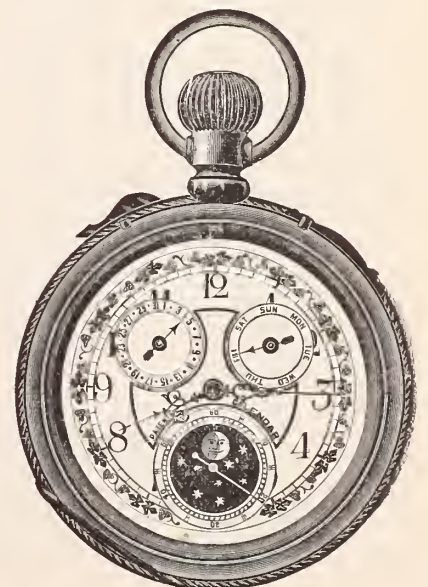





### R. A. Kettle and the Dogs.

At one end of the rope was a seedy-looking, uncouth fellow of the genus tramp, at the other a huge mastiff, as they slouched into the office of the American Waltham Watch Co. on the fifth floor of the Columbus Memorial building. Ives Lake approached the counter cautiously, with a weather eye on the beast.

"Well?" said he.

"Where's de man wot wants a dog?"



asked the newcomer, as he rested both tattered elbows on the counter.

"Don't want a dog here," responded Ives, edging away as the brute sniffed through the gate rails. The old man drew from his pocket a soiled and torn bit of paper.

"Where's Kettle?" he inquired.

Ives, glad to escape, called Manager Kettle from his private office.

"Now, this here's a watchdog as is a watchdog," said the tramp, as Mr. Kettle approached. "He's a good un. He's—"

"But, my dear man—," interrupted Mr. Kettle, and a low growl made him pause.

"There ain't no dog like him anywhere," continued the tramp. "He's a fighter from

Fightersville, too, an'—" A yelp in the hallway brought a deep growl and the tramp with difficulty restrained the brute as a man entered with a mongrel pup.

"Where's the man,—," began the new man. With a bound the big brute sprang at the pup, but its owner fled precipitately dragging the pup after him. Growls and yelps came from the hall in various keys as the tramp continued:

"Now, this here's jes the dog you'uns ought ter hev."

"But I don't want a dog," remonstrated Mr. Kettle. "I've no use for a dog."

"Then whatcher advertise fer; whatcher make a feller tote a big dog up four stairways fer?" And he laid the soiled bit of paper on the counter. It read:

**WANTED.**—A good watchdog. Bring same to R. A. Kettle, fifth floor Columbus Memorial building, between 10 A. M. and 4 P. M.

It required finesse to convince the man that he had been imposed upon by some practical joker. He left, muttering, only to be succeeded by another and yet another, till the dog pound had yielded up all its treasures and the "strays" had all been gathered in.

But after the first encounter, a sign faced the dog fanciers.

NOT IN.  
R. A. KETTLE.

*Stephen Parlin*

CHICAGO.

### The Wiles of the Farmer.

He was long and lank; the tan of last July had faded to a light brown upon his cheeks; the wrinkles on his forehead told of varying successes in the protection of harvests from drouth and rust, chinch bugs

and grasshoppers; but the vicissitudes of a farmer's life hadn't driven the light of kindness from his eye, and as he hobbled into C. S. Durfee's store and laid his lean hands on the outer edge of a show case, he singled out the proprietor with a look of genuine commiseration.

"Still in the business?" he asked.

"What business?" inquired the astounded Mr. Durfee.

"Sellin' silver things."

"Well, we have a few of them left," the reply being accompanied by a modest wave of the hand towards cases and shelves well stocked and walls full hung.

"Yo' don't say. Waal, I am confusticated! I'm glad, though, cause I thought like as I mightn't find you here. You see, I've been readin' about silver goin' way down, gettin' cheaper than dirt, some of the papers said; mines closin', cause it wasn't wuth the minin'; white metal so cheap yo' couldn't give it away. All so, isn't it?"

"Pretty near; now there's that set—"

"I knew it—and I sez to my wife, sez I: 'Maria, comin' next March, we've been married 31 years. Never had no silver weddin', did we? And she said 'no,' like a truthful girl, cause somehow we couldn't afford no celebration when the time cum round nigh six years ago. A flood washed out the corn that year and the difthery carried off John and Nell," and he paused a moment and furtively blew his nose. Then he resumed: "So when I heered how





silver had slumped, I said, 'Now we'll celebrate that silver weddin'. Next time I go to town I kalkerlate I'll bring back a load of tea services, and dishes till you can't rest, Maria.' So here I be, as I done promised. Say, how much's that soup bowl over there?"

"That fruit dish would cost you \$30."

"Sho' now; you're foolin'! Mebbe, though, that's cause o' the gold linin'. Now, how's them spoons marked?"

"Those are sterling. You can have them for \$18, and that's a close figure. Pretty pattern, too."

"Eighteen hoe-handles! Goshamity! Then you ain't a-givin' things away," and the old fellow's face fell so that I stopped smiling to pity him.

"Not much."

"And Maria and me can't have no silver weddin'."

"That would be too bad," agreed the sympathetic proprietor.

"I don't mind it so much myself, you know," smiling weakly, "but it'll be dreff'l disappointing to Maria. She's gettin' old, you see," and he braced up and tried to look cheerful. "What with worry and rheumatiz, she isn't kalkerlated to stand many castin'-downs. Come, now," and he dropped into persuasive tone, and inside of 10 minutes he had under his arm "a little sumthin' for Maria, ennyhow," a \$2.50 plated salad bowl that he had prevailed upon the man of silver to let him have for 79 cents—"takin' my last, sure as blazes."

I felt sorry for the poor old fellow till I saw him negotiate a horse trade an hour later. By mere accident I happened along just as he was pulling from his hip pocket a roll of bills containing at least \$100. He was trading a \$15 plug for a horse that was worth \$75 if it was worth a cent, and he paid just \$25 "boot."

*Ralph W. Cram,*

DAVENPORT, IOWA.

### The Realm of Sultan Rutherford.

The retail jewelry trade in Lancaster runs in one direction—to auctions. The well developed fondness of the local members of the craft for this method of getting even with the other fellow and disposing of stock that has lagged in the race, has grown with what it has fed on for some years until the "positive closing out" auction has come to be looked for as an annual visitor equal in regularity to the blue bird. The people want it and no other species of public amusement is so popular.

The number of stores and auctions in this city have for some years been running a very close race and are now neck and neck—with 16 jewelry stores and 14 auctions, the latter in a little more than the same number of years.

Col. J. M. Rutherford, the lightning manipulator of king's English, introduced in our midst this happy method of cleaning out old stock. He is a sort of Pooh Bah or local

John Y. McKane. A sale in Lancaster without Rutherford would be a foregone fizzle. These evidences of appreciation have made such an impression on the Colonel that he finally decided to make his permanent home here, the more thoroughly to keep his fences in order and warn off poachers.

During the merry month of December, just passed, the Colonel scored one of his greatest local successes, and it is Ernest



Zahm's turn to smile. Other jewelers have expressed some very emphatic opinions on the subject, but they either remember when they were in the same boat or console themselves with the reflection that they will do the trick themselves some day. Meanwhile Lancaster holds the champion's belt for jewelry auctions, and Rutherford, with fourteen medals on his ample breast, looks as contented as a man can who is just getting over his eighth attack of grip.

*J. S. Landis*

LANCASTER, PA.

### Her Teeth as Old Gold.

Most of the Queen City veterans of the jewelry trade have passed away, but some old landmarks still remain. Joseph Noterman heads the list, having been over forty years in the business. He rose from the bench to the head of a prosperous house.

One of the oldest and best known jewelers is I. N. Laboiteux, of Duhme & Co. He is full of reminiscences. He remembers when as a traveler, along in the fifties, how he had to blow the dust off the counters, or wipe away the fly specks to see how the stock was broken. Many a time he found cards tacked on closed doors, in small western towns, announcing that his customers were away on fishing excursions.

Numerous amusing incidents happen at this house daily, but the most ludicrous one occurred a few months ago. An old acquaintance entered the store. Mr. Laboi-

teux, re-adjusted his spectacles as he sighted the lady, scenting a smart sale, and he would do her the honor to wait on her. She approached him with an air of confidence, taking a parcel from her reticule and whispered,

"I brought you these to sell for me." She laid on his desk a set of false teeth on a gold plate. "They're good gold," she urged. He recovered himself. It was evident she meant to sell the gold, and so he made an estimate and told her what they were worth.

She cried out in surprise, "They cost \$60." He explained that the plate would have to be sold as old gold, and she innocently remarked as she returned them to her satchel, that she thought "he could find a customer whom they would fit."

*J. E. Harkrader*

CINCINNATI, OHIO.

### Ed. Boehmer's Striking Clocks.

Everybody who knows Ed Boehmer, the N. Broadway jeweler, knows he is a crank on clocks. He not only has his store filled with clocks of all kinds, but has even stocked his residence with a choice assortment of timepieces. Notably, he has two large clocks in the hall. Now, these clocks are very good friends, and when they decide to strike they generally join hands and do so together. But their internal constitutions must be slightly different, for in real cold weather they often vary in their times of striking. While this variance is generally very slight, still it is often sufficient to cause much confusion, often causing the bells to sound one right after the other, ringing, for instance, 24 times at noon.

Mr. Boehmer has often threatened to isolate the refractory clock if it would not arrange



to strike the hours at the same time with its partner, but a recent experience has caused him to resolve to treat the old clock very tenderly. Mr. Boehmer is not in the habit of going home at 9 o'clock every night in the week. In fact, it is now occasionally after midnight when he retires. He does



not, upon inquiry of his wife, explain that the cars were so crowded he couldn't get home sooner, and thus give his wife a chance to say feelingly, "So the cars were full too, were they?" No; he simply looks at the clocks, and if it is a safe distance from striking time he simply says soothingly:

"Half past ten, dear."

He generally arranges to come in near the half hours so as to be a safe distance from striking time. The clocks strike one at every half hour and so he can say "half past ten, dear," if it's half past two without fear of detection.

But one very cold night recently Mr. Boehmer must have lost his time table, for he wandered in at ten minutes of four. It was so cold that one of the clocks had stopped running.

"What time is it, dear?" asked a soft female voice. He looked at the clock. One was 3.50 and the other was — stopped.

What answer to make was a puzzle. He knew that if he said half past ten, the clock would soon strike four, so he calmly answered:

"Oh—oh—it's about two o'clock, this time."

"Only two o'clock?"

"Yes, that's all."

For a few moments there was silence. Then the clock that was going slowly and solemnly struck one, two, three, four. This time the female voice was not quite so gentle.

"What time did you say it was, Ed?"

"Why, two o'clock."

"Two o'clock, why my gracious, how could the clock strike four at two o'clock?"

"Why, easily dear. You're sleepy if you think you heard the clock strike four. You know what you heard?"

"Well, what?"

"Why you heard both clocks striking two, one right after the other. See?"



ST. LOUIS, MO.

### He was Having His Watch Repaired.

There is probably no calling in life that requires more patience than that of the watchmaker. His vocation requires not only the most thoughtful attention, but delicacy of touch and complete control of his nerves. He is often subjected to tirades that would excite the patience of Job himself. It is known how often it happens that a customer will leave a watch to be repaired or cleaned in a jewelry establishment, and after having had it fixed, go away only to return with curses upon the head of the watchmaker, because his watch don't run, when he has, in fact, simply forgotten to wind his precious timepiece.

The oldest watchmaker in Elmira to-day is perhaps John Bally, a member of the firm of John Bally & Son. Several years ago while Mr. Bally was working at his bench, an

elderly and arbitrate German citizen entered his store. The man's name was Jacobs. He was a very wealthy tanneryman. He asked Mr. Bally if he could repair his watch, and have it done for him by 2 o'clock that afternoon. It was then 10 o'clock in the forenoon. Jacobs stated that he must catch a train for New York at 4 o'clock, and must have the watch. Mr. Bally agreed to have the work fixed by 2 o'clock, and the customer withdrew.

The hour of 10.30 o'clock brought him again into the place to inquire if his watch was not yet done. Mr. Bally told him that it was not, and laughed to himself over the man's sudden return, telling him that it would be done at 2 o'clock.

"Vell, get it done," said the German, and out he went, only to return again at 11 o'clock and ask the same question. Mr. Bally became nervous and disgusted with his customer and again told him it would be done at 2 o'clock. Jacobs walked up and down the store, cursing and swearing because he had to wait so long. He went out and again returned at 12 o'clock, just as Mr. Bally was putting on his coat to go to dinner. He inquired if his watch wasn't yet done. Mr. Bally gave him a searching look and asked him to let him have the hat he was wearing. The watchmaker had taken the watch to pieces and arranged the parts upon his work table. He gathered them up and dumped them into Jacobs' hat.

Jacobs was mad and so was the Elmira jeweler.

"Vell, vat you dinks I do mit dese," said Jacobs.

"I don't give a d— what you do with them; take them and get out of here," replied watchmaker Bally.

The customer again went out, and returned bareheaded at 1 o'clock, when Mr. Bally had returned from dinner. Jacobs still carried his hat in his hand, containing the pieces of the watch. Jacobs insisted that Mr. Bally must fix his watch.

"It will cost you another dollar," said the watchmaker.

After some time spent in idle argument, Jacobs was forced to agree to pay the dollar and also not to again call at the store until 2.30 o'clock, when the watch was to be done. The timepiece was repaired at the appointed hour, but Jacobs didn't appear on time. When he did appear it was nearly 4 o'clock. He missed his train and could not find words sufficient to heap upon the suffering, nervous watchmaker.

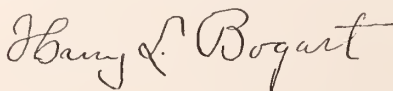

ELMIRA, N. Y.

### She Took Him at His Word.

It is certainly amusing to watch customers in a jewelry store, for "they say such things and they do such things." It is one branch of trade where human nature asserts

itself, and in many cases in a ludicrous manner.

It was some time ago that an old man dropped into Edward Moulton's jewelry store. He was a typical Irishman, a little mite inquisitive, but jolly looking. He went from one counter to another, looked everything over from the secret society charms to the big old fashioned clocks in the rear of the store and said:

"D'ye have marriage rings?"

"Certainly, sir," replied the clerk.

"Well, let's see them! Something foine, mind ye. Don't mind the expense."

Several trays of rings were handed out for the old man's inspection, and after looking the lot over he selected one which he thought was about the right size. The selection proved to be in good taste, the ring being a plain band costing \$10. The ring was tucked away in a little box, the old man paid over the price, and with the package safely stowed away in his waistcoat pocket, sailed for the door. But half way he stopped suddenly, looked distressed and returned to the clerk.

And then, in a stage whisper that wreathed the face of the grandfather's clock in smiles, the old man asked:

"Boy, ef she won't have me, kin I get my money back?"

The clerk said he could; but though that was months ago, the old man never came back.

Another little incident that occurred in the same place recently shows a woman's knowledge of values in a jewelry store.

"That's a beautiful chain in the window," said a woman to an obliging clerk; "how much is it worth?"

"Seventy-five, madam," answered the clerk, obsequiously.

"Then you may let me have it," continued the woman as she laid a dollar bill on the beveled plate glass show case.

"But it's dollars, madam, instead of cents," replied the clerk, the corners of his mouth wreathing themselves into a smile.

Tableau:— Clerk with a growing grin, blushing lady who says something about not knowing the price of jewelry, while from the repairer's room comes a long drawn snicker.

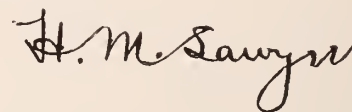

WORCESTER, MASS.

### The Gullibility of the Public.

Prof. Fields, a prominent young teacher, entered E. Lowinsohn's jewelry store recently, and asked the proprietor to make a trade with him, at the same time drawing from his pocket a pair of spectacles.

"Now, I want to exchange these for another pair," said the Professor. "They are for a young lady, and these have some little fault in them."

"Of course I can make a trade with you."





# Bee Main Springs

... FIT ALL ...

American Watches.

H. BEALMEAR,  
 --- DEALER IN ---  
 Clocks, Bronzes and Supplies,  
WHOLESALE ONLY,  
 No. 25 SOUTH CHARLES STREET,  
 BALTIMORE, MD.  
 TOOLS, WATCH MATERIAL, JEWELER'S FINDINGS  
 AND JOBBING STONES.

Jewelry Boxes

... AND ...

Jobbing Stones

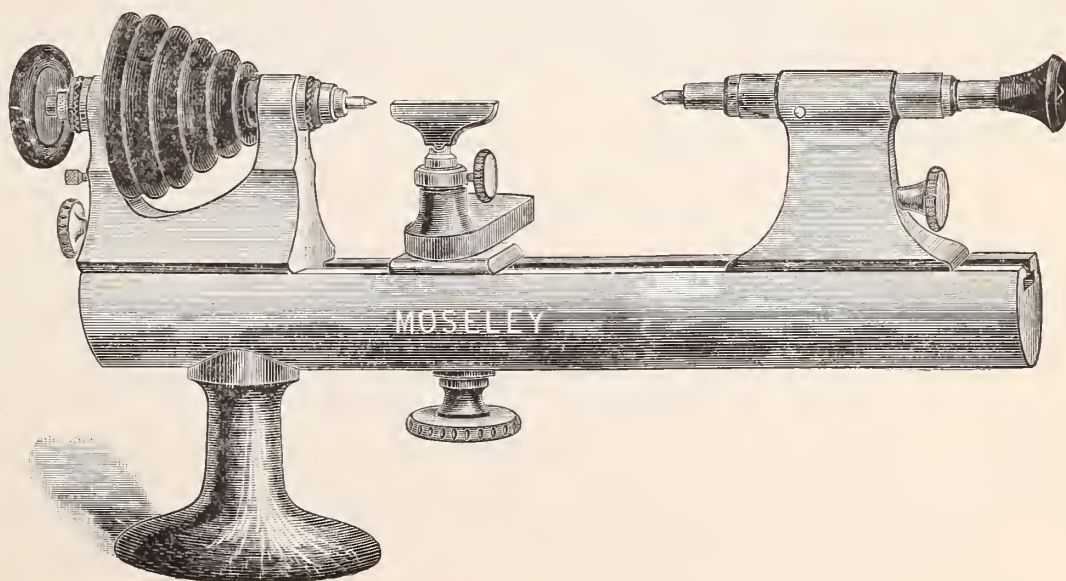

# OUR PLUMP 8kt. SOLID GOLD RINGS

ARE THE GREATEST SELLERS THE TRADE EVER HAD.

## WHY?

BECAUSE OF THE PRICE.

VELVET LINED CHAMOIS TRAYS IN ARTISTIC COLORS.

DIAMOND, PEARL AND COLORED STONE EFFECTS.

ORDER QUICK!

THEY SELL QUICKER!

Five of our Plump 8kt. Rings, selected at random and subjected to U. S. Govt. assay, proved eight and one-tenth kt. fine.

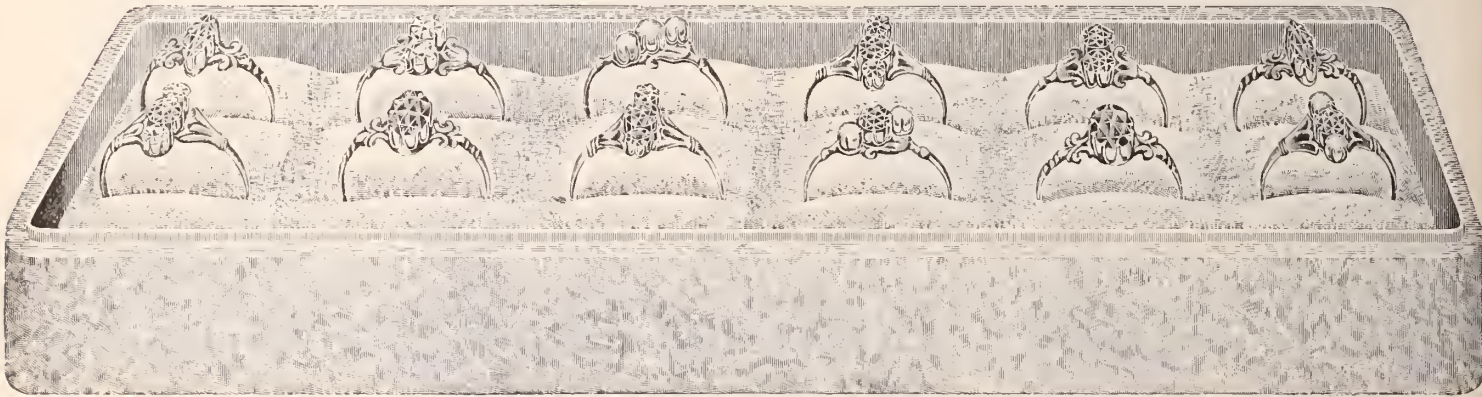

No. 1894.

Here's another Assortment, put up in the same style, Plump 8kt. Solid Gold but for **EVEN LESS MONEY** than the 1894.



No. 1894½.

Nicely Assorted Stones.

Positively the Cheapest Ring on the Market.

Excellent Appearance.

Order from any Jobber. If he can't supply you write direct to us.

OUR NEW SPRING LINE, IN 10kt. GOLD ONLY, OF WHICH WE ARE NOW SHOWING SAMPLES, COMPRISES:  
**LACE PINS, BROOCHES, CHARMS, DROPS, STUDS, SCARF PINS,**  
**EYEGLOSS CHAINS, NECK CHAINS, PENDANTS, &c., &c.**

## E. L. SPENCER & CO.,

MAKERS OF GOLD JEWELRY,

62 PAGE STREET,

PROVIDENCE, R. I.



answered the dealer, "but you will have to pay me the difference in price."

This the Professor was willing to do, and after selecting a pair of spectacles, he paid \$1 for the difference. About 24 hours later, when a young lady entered the same jewelry establishment, and approaching the proprietor asked if Prof. Fields had purchased a pair of spectacles the day before, the proprietor answered in the affirmative.

"Well, will you do me the kindness," said she, "to exchange these for another pair?" at the same time showing the glasses that had been sold to Prof. Fields the day before.

"Of course," replied Mr. Lowinsohn, "I can make an exchange with you, but you will have to give me a certain sum to balance the difference." The difference was \$1, and the young lady, after trying several pairs, picked up the same pair that Prof. Fields had brought to the store, and trying them, felt certain that they were just the pair she wanted.

As a favor the jeweler engraved her name on them, free of charge.

*E. P. Smith*

BIRMINGHAM, ALA.

### Jewelry for Shingles.

Washington suffered probably as much during the late financial stringency as any of the Pacific Coast States, and some rather odd expedients were resorted to in order to compensate for the lack of ready cash. One of these was the so-called "shingle scrip," reminiscences of which are still floating around. Washington's principal industry lies in her lumber and shingles, and when there is no demand for these products the entire State suffers. Therefore, last Summer, when lumber and shingle shipments dropped off, money became scarce, and the



merchants naturally felt the effects severely; especially the jewelers, who had large stocks, and who usually feel first the stoppage of trade. It became then necessary to adopt a circulating medium, and in the northern part of the State shingles passed as currency in grocery stores, drug stores,

barber shops, and even, it is said, in police courts.

Up at Blaine, a commercial traveler informs me, the jewelers had stacks of shingles piled up in the rear of their stores, taken as payment for rings, watches, alarm clocks and wedding presents. One day an express wagon drove up to the leading firm and unloaded a number of shingle bunches. In a few moments a red cheeked lass entered the store, nodded coquettishly to the apprentice, and with a smile asked for the "boss." The "boss" jumped up from his bench, where he was examining the interior of a watch, surveyed the blushing damsel with his monocle, and asked what he could do for her.

"If you please, sir," she stammered, as she looked down at her feet, in confusion, "me an' Mike—well, that is—Mike and me thought we'd get married. You see, Mike works in the shingle mill, and we want a ring."

"Ah, indeed! And where is Mike?" queried the now interested jeweler.

"He's outside," she simpered. "Wuz 'fraid to come in." And then she disappeared, to reappear in a few minutes leading the bashful Michael by the hand. Michael was six foot tall, and well proportioned. He had an impressive countenance, that would have looked well on a souvenir spoon. He was bashful, however, and felt rather mean about it. After considerable giggling and one or two attempts on the part of Mike to make his exit, the plain gold band was selected. It came to \$10.

"We have no money, sir," said the maid, "but Mike has 100,000 shingles coming to him, and we have brought 10,000 for you in payment for the ring."

This amused the commercial traveler exceedingly, and he went outside to laugh. But the jeweler merely shrugged his shoulders, and said: "All right, bring them in, and place 'em behind the counter. I guess people will have to use shingles to roof their houses one of these days, and in that event I will have a chance to dispose of them."

The commercial traveler would not give names, but vouches for the story.

*Victor H. Beckman*

TACOMA, WASH.

### Diamond Mining in the Dump.

The diamonds were missing. The two precious coruscating \$1,000 brilliants were nowhere to be found. The merchant we speak of, Gen. George H. Ford, of New Haven, had laid them on his desk, and after critically scrutinizing them, had turned his attention to some traveling friends who had come in, and who spread out some of their specialties upon the desk. The commercial men had now gone. It was 5 o'clock P. M., and the lady who had ordered the two brilliants and their settings for earrings appeared.

In vain did the General search for the missing treasures. No trace of them appeared. The little torn envelope in which they lay was gone also. It had perhaps been brushed off the desk. Every nook, corner and crevice, every imaginable place were investigated. All inquiries from assistants were likewise vain. 'Tis said riches have wings. So it seemed as regards this pair of diamonds. The store had been swept a half hour before the gems were missed.

Gen. Ford directed a thorough examination of the gutters of the street, but to no avail. The city's street cleaning carts had just taken away all the accumulations of the day in the street. Taking a carriage, Gen. Ford found the City Inspector of Streets, genial Patrick Ward, now deceased. The



case was laid before him. The shades of night had now fallen, and the quest was postponed to the morrow. Aurora had but just opened the gates of day; it was three days before Christmas, when City Inspector Ward, with his cohorts marshalled before him, and mounted an ash barrel inquired in his stentorian tones if any one of them had found anything of value the afternoon before. No one had been so fortunate.

Still undaunted, Gen. Ford obtained the services of the men whose carts had been in use near his store the day before. The laborers pointed out the proximate locality where the particular dumping was done. A stake was driven in the center of the spot designated and a circle of 35 feet in circumference about it was described. Over 25 loads of earth and other street scrapings were taken up and being in congealed lumps, the ground having frozen during the night, were laden into barrels and carted to a raging fire, where the masses were thawed out.

About 15 barrellfuls were run through a sieve, when lo! the missing envelope appeared and in it were the missing diamonds. It was a good morning's work and the shining faces of the laborers as they pocketed the bright dollars bestowed by the General, showed that they shared with him in his satisfaction.

*Jerome B. Lucke*

NEW HAVEN, CONN.



### A Burglar Proof Safe (Sic.)

Your correspondent walked into the jewelry establishment of E. A. Williams, the other day and noticing a great hole in the door of the fine fire and burglar proof safe, which has double doors outside and inside, inquired:

"What is the matter here?"

"Oh!" said Mr. Williams, "my combination got out of order this morning and wouldn't work, and I could not get my goods out of the safe. I was terribly worried over the matter, and thought I would have to send the safe with its contents back to the factory and have it cut to pieces in order to get the goods out.

"After studying over the matter for some time, I concluded to send for one of our local machinists and ask his advice. He came and told me that he could open the safe by cutting the door. As I had paid a big price for the guarantee of the safe being burglar proof, I told him he would not get inside of it in a week. He consented to take the job, however, and with an old drill, a chisel and a hammer, opened that safe as you see, in exactly two hours, and sharpened one of his tools in the meantime."

Mr. Williams said for the past three years he had slept perfectly contented thinking that his safe would resist every effort, short of an earthquake, and then to sit down and see an ordinary mechanic with three old obsolete tools, tear the thing to pieces, was too much for him, especially as he had paid for the burglar proof qualities of the concern.

*A. W. B. Oliver*

LYNCHBURG, VA.

### Time Do Move.

Geo. Zumar, watchmaker for Wm. Kendrick's Sons, has many queer stories to tell about the changes that have taken place in the city since he first came to know Louisville.

This city was then but a small town and his store was one of the first here. He often took dog and gun and strolled over to the Point, a strip of land so called by reason of its shape formed thus by Beargrass Creek, which then emptied into the Ohio at the foot of 3d St., only two blocks from his store. Here was his hunting grounds. Mr. Zumar is so regular in his habits that he even now hardly knows the extent of Louisville, save by hearsay, as he seldom goes anywhere except to and from his work. On Thanksgiving a year ago Mr. Montgomery, one of Wm. Kendrick's Sons' salesmen, invited Mr. Zumar to dine at his house at Floyd and Ormsby Sts. Mr. Zumar was surprised at the growth of the city and said: "Why here is where I used to shoot snipe."

Mr. Zumar came to Louisville in 1823 from Baltimore, and entered in partnership with Mr. Beard, composing the firm of Beard & Co., who did business on Main St. between 3d and 4th Sts. Mr. Zumar was

watchmaker and Mr. Beard was silversmith. Mr. Zumar afterward sold his interest and went to West Port, Ky. He afterward removed to a farm near Six Mile Island; and later he went to Cincinnati, but finally drifted back to Louisville and went to work for Wm. Kendrick's Sons, where he is still employed. He is now 90 odd years of age. In his younger days he was one of the most skilful workmen in this section of the country.

Many a difficult piece of work has been sent to him by his fellow workmen. Wm. Kendrick, Sr., father of the present member of the firm, learned his trade at the bench of Mr. Zumar.

*David O. Montow*

LOUISVILLE, KY.

### His Maiden Trip a Howling Success.

Every comic paper and every humorous writer has made the unsophisticated resident of the rural districts the butt of their jokes, depicting them as blowing out the gas, trying to extract with a huge jack-knife the knob of the electric call bell in the hotel apartments, thinking it a new fangled collar button, and going through other equally ludicrous experiences. That the rustic is not the only visitor to the metropolis who becomes the prey to the wiles of modern

inventions, was verified in the experience a few years ago, of J. E. Gould, at that time salesman for S. W. Gould & Co., Attleboro, Mass.

It was on one of his first trips, and during his stay in New York he stopped at the Astor House. Desiring, one evening, to call a bell boy he stepped up to a knob in his room and pressed the button. Waiting a few moments and no boy appearing, he rang again and again, but all to no purpose, at least, not as he desired. In the meanwhile, the alarm bells outside were furiously clanging, the thoroughfares in the neighborhood were crowded with apparatus, and excited firemen rushed to and fro through the building, while the guests in alarm hastened forth to discover the cause of the commotion.

In blissful ignorance of the excitement that he was causing, Eddie continued to press the button, and it was only when a member of the department burst open the door of his room, that he learned that he

had been working an "auxiliary" alarm box. It cost Eddie many cigars to clear away in smoke the laugh which his greenness occasioned.

*U. H. Mason*

PROVIDENCE, R. I.

### One of His Bad Days.

He left his home in the northwest bright and early. He had carefully tied a piece of red cord to the ring of his watch. He had a duty to perform and left his office at 11 o'clock in the forenoon. He gazed in the windows of the shops and at the gay crowd in the streets. A corner fruit stand attracted his attention, and taking out his watch, glanced at the red cord, opened the case and gazed vacantly at the face.

Then he went into Muhr's store and spoke to Simon Muhr. He said "Good morrow! How do you do?" and glanced at his watch again. When he had shut it, he looked at Mr. Muhr pitifully.

"What is it?" asked the jeweler.

"I know not," said the man, and he wandered from the store.

He walked along aimlessly and purchased an early afternoon paper. He entered the Post Office and dropped the loose journal in a box. Again he looked at the watch. Stepping briskly from the building with features brightened, he crossed Chestnut St. and studied the chronometer at Caldwell's, and then he took out the watch again to compare the time. He toyed with the cord thoughtfully and failed to open the watch. The bright look fled from his face. And thus he journeyed aimlessly and unsteadily from place to place until finally he found himself in front of his home.

The man went in and his wife watched him critically.

"Humph!" said she. "Another day!"

"Yes," replied the man. "What means the red cord?" His wife informed him.

"What was the matter when you were here at noon?" asked Mr. Muhr, of the man, later in the day.

"I wished my watch mended," he replied with a sickly smile. "This is one of my bad days."

*Hugh H. H. H. H.*

PHILADELPHIA, PA.

### The Hamlin Necklace.

Probably the most interesting and surely the most valuable piece of jewelry owned in Maine is the Hamlin necklace which is the property of Dr. A. C. Hamlin, of Bangor. The necklace was originally made of 100 tourmalines which were found at famous Mt. Mica, at Paris, Me. The tourmalines found in Brazil, Russia and near the Elbe are said by British mineralogists not to equal those in the Hamlin necklace.



# EBONY AND SILVER TOILET ARTICLES.

A COMPLETE NEW LINE OF PHOTO FRAMES IN STERLING SILVER-MOUNTED EBONY, ALSO SOLID SILVER.

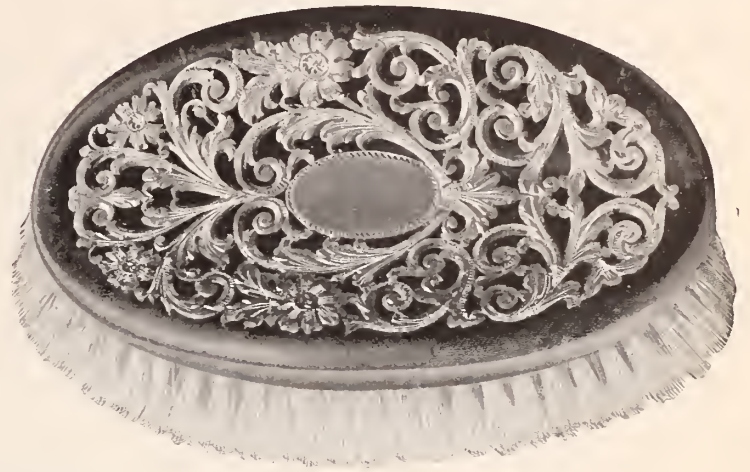

AS this combination is to be very fashionable this season, we have produced the most elaborate line on the market in Ladies' and Gentlemen's Toilet and Manicure Articles. These goods are mounted with pierced Sterling Silver, and decorated by the most artistic hand engraving

A full line of these goods will make a beautiful window display.



## MADE IN

HAIR BRUSHES.  
MILITARY BRUSHES.  
CLOTH BRUSHES.  
HAT BRUSHES.  
BONNET BRUSHES.  
GENTLEMEN'S COMBS.  
LADIES' COMBS.  
ROUND AND OVAL MIRRORS.  
WHISK BROOMS.  
SHOE AND BUTTON HOOKS.  
NAIL POLISHERS.  
POWDER AND PUFF BOXES.  
NAIL POWDER BOXES.  
SHOE HORNS.  
NAPKIN RINGS.  
PAPER CUTTERS.  
HAND BLOTTERS.  
PIN TRAYS,  
NAIL FILES.  
CORN KNIVES, etc.

A complete new line of Sterling Mounted Ebonized Briar Wood Pipes.

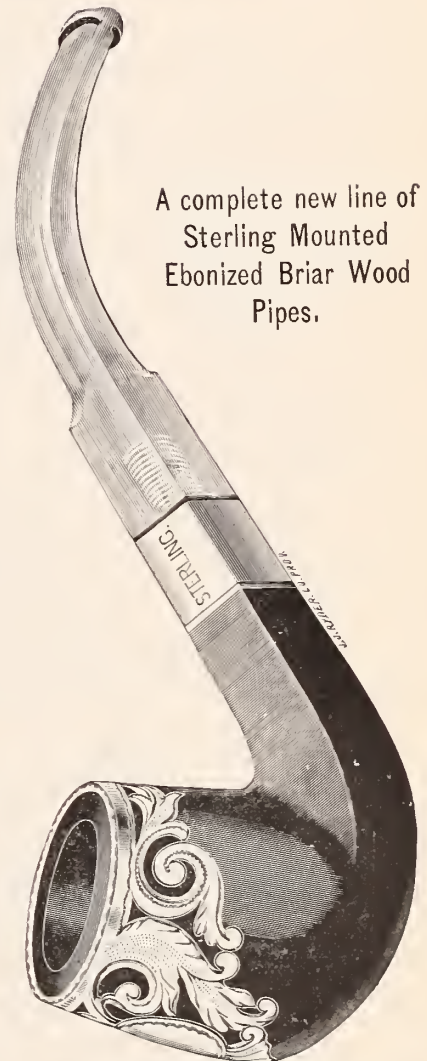

THESE PIPES ARE GENUINE BRIAR, NATURAL OR EBONIZED.

## J. N. PROVENZANO,

GOLD AND SILVERSMITH,

No. 39 UNION SQUARE,

NEW YORK CITY.

# AJAX INSULATORS.

PATENTED OCTOBER 28, 1889.

Will Protect all Watches Against Magnetism.

THEY are Cheap; THEY Reduce Wear and Tear of the Case;  
THEY Protect from all Ordinary Magnetic Influences.

PERFECT IN  
ACTION.  
CONVENIENT IN  
USE.



Educate your Customers by talking up Ajax Watch Insulators.

MADE IN VARIOUS SIZES.

The Trade are Cautioned to Use no Other.

## The Newark Watch Case Material Co.,

MANUFACTURERS OF

PENDANTS, BOWS, CROWNS, SPRINGS, Etc.

19 Ward Street, Newark, N. J.



The necklace during the World's Fair was admired by thousands of people. It was exhibited by Tiffany & Co. near their big diamond and it attracted almost as much attention as the big stone. When the Maine building commissioners started to make up a mineral display from the Pine Tree State they wanted the necklace, but Dr. Hamlin refused to let them have it, because they would not insure it. While the necklace was in Chicago, Dr. Hamlin was offered \$50,000 for it, and made answer to the admirer who wanted it that no money in the world could buy it.

The necklace is now in Boston where it is being exhibited. Thence it will go to Dr. Hamlin's daughter, of Brookline, Mass., as her property. Dr. Hamlin says that when she dies the necklace will be donated to Harvard College. The senior class will have charge of it. Dr. Hamlin says that it will be seen at great events and will be worn by the wife of the Governor of Massachusetts, or the wife of the President of the United States, if she is in attendance. The necklace now contains 17 tourmalines of every shade and variety.

*Harry W. Hunt*

BANGOR, ME.

#### An Hibernian Description of a Watch.

The illiteracy of the general public manifests itself in many ways, but its comicality assumes more ample proportions in the jewelry trade than in any other. I make this assertion with the happy foresight that no one will offer a contradiction. In my weekly rounds among the jewelry stores, the usual reportorial task has developed into a recreation, in which the many phases of character of shopman and customer, and traveling man and his patron, are brought into ludicrous prominence. I have listened to so many amusing remarks gravely intended, have witnessed so many humorous incidents and comical situations, that I can now invest myself in stoical raiment, and stifle the Vesuvius of mirth that formerly would have found vent.

A personal experience may serve as an illustration of this preamble. On a recent cold morning when the darkness of Pittsburgh was illuminated by a heavy fall of snow, my duties as a CIRCULAR correspondent brought me to the store of B. E. Arons. I had been an interested listener to that genial proprietor's remarks on the existing condition of the world and its people, when the door opened with a fling, bringing with it a wave of the outside atmosphere and a gentleman of Hibernian extraction and whisky injection. He evidently had been fortunate in securing an annual license, for his elaborate attire was further enhanced by a blazing stud in a scarlet tie and a sparkle on the little finger of his right hand. With a stride and a swagger, he approached the proprietor, and with unequalled pomp-

osity and the thickest of accents, asked: "Hev yez anny watches?" On being assured of a surplus of the best makes, he continued: "It's the besht Oi'm afther, an' Oi will adjudicathe till yez the perquzites O'im afther. Oi wants, moind ye, a *Ondiani-tur-r-ined* case, opinion movement, an' Oi wants it *suggested to hate* an' cold!"

*Maria A. Coyle*

PITTSBURGH, PA.

#### The Crank and the Suffering Jeweler.

Jewelry stores have not immunity from cranks any more than other branches of business, as L. S. Stowe has cause to remember. Mr. Stowe has been in the jewelry business in this city for thirty years, and during his time has had some funny experiences. One happened several years ago.

A man, evidently a countryman, judging by his dress and actions, sauntered into the store and demanded his watch, which he claimed to have left there for repairs. The repairer looked through his case and politely informed the stranger that he had no such watch as the one described. The stranger was positive that the clerk was mistaken and ordered him to make another search, with the same result as before. Then the stranger became angry and stormed and fretted, using his auctioneer-like voice with such good effect that the other customers in the store probably thought he was being buncoed.

The clerk was in a quandary, but Mr. Stowe came to the rescue and told the man that he must have left the watch somewhere else. The stranger was positive that he had not, but Mr. Stowe finally persuaded him to make a tour of the other stores on Main St. He did so, or pretended to, but returned shortly and again demanded his timepiece, in tones that for a time threatened to create a panic among the other customers. In despair, Mr. Stowe finally called one of his clerks and giving him a description of the missing timepiece sent him in search of it. The watch was about 75 years old, and more valuable on account of its antiquity than anything else, and the clerk had no difficulty in locating it.

The countryman was still executing his war dance when the clerk returned, and was nonplussed to think he had been mistaken; but he was more than crestfallen when Mr. Stowe reminded him of the fallibility of man's memory, and advised him to be less positive in the future.

*H. J. Healy*

SPRINGFIELD, MASS.

#### The Story of a Diamond Ring.

Mabel and Evalene Scott are two maidens whose smiles are much sought after by the young gentlemen of their acquaintance in the City of the Golden Gate. Mabel had a lover whose intentions were to share her home and happiness. He soon found himself engaged to marry Mabel, but he was not happy until her little white finger bore tangible evidence to the world that she was engaged. There was one drawback to the immediate realization of his desire in this regard, however, namely, he had not the necessary coin to exchange for the ring. But an obliging Kearney St. jeweler agreed to supply the brilliant evidence of his affection for \$90, on the instalment plan.

But two months' instalments had been paid when the young man lost his situation and he was unable to keep up his monthly payments. The jeweler demanded the money or the ring. What to do was a difficult problem for the young man. But like most similar serious problems of life, the question settled itself. The young lady seeing her lover out of work and with no very bright prospects of the marriage materializing, decided to break the engagement, and returned the diamond ring. But having paid \$20 on the jewelry the youth did not like to give it up, so

he confided his trouble to a friend, who was at the time engaged to Evalene, Mabel's sister. A happy thought came to the friend. He wanted a diamond ring for Evalene, and so he assumed the monthly payments with the jeweler, and took the ring off his friend's hands. In due season the ring with glittering brilliancy, told all Evalene's friends that she was engaged.

Matters went on smoothly in the Scott mansion for some weeks, when all at once a cloud gathered over the horizon of Evalene's love dream. Papa Scott concluded it was necessary for the good health of Eva that she take a vacation trip to the World's Fair, and prolong her stay by a visit to the "old homestead" in Vermont. He also thought it safer that she should not unduly excite the cupidity of strangers by displaying a diamond ring on her index finger. So the engagement ring was returned to the second donor. Two sisters had worn the same engagement ring without either suspecting that it was the same article. Two lovers had gone broke to pay for the token, and now a diamond ring was for sale cheap.

But fortune again smiled, and the brother of the two disengaged maidens was struck with a spirit of generosity and proposed to





make each of his two sisters a present. Mabel wanted a diamond ring. The brother was a personal friend of Eva's late betrothed, and consulted him on the subject of how and where to buy jewelry to the best advantage. He made an engagement to accompany his late brother-in-law-that-was-to-be, to a certain jobbing house on Sutter St. In the meantime, the latter visited an acquaintance, a salesman in the Sutter St. house, and explained the situation to him, and left the twice returned engagement ring to be sold. In due time the parties called, the salesman had a special bargain in a solitaire diamond ring, and on account of closing out the line, he would take \$50 spot cash for the sparkler. And now Mabel wears the same ring she and her sister both have worn as engagement rings, but is none the wiser for it. In fact, she rather likes it the better for it reminds her of one very like it she once wore, but returned to the giver at the end of a short but sweet marriage engagement. Each lover lost \$20 on the ring, and the brother presented a \$90 ring to his beloved sister, at a net cost to himself of \$50. And no one knows anything about the history of that ring, except the two discarded lovers.

*Abel Benton*

SAN FRANCISCO, CAL.

**Mr. Rogers is very much Dead.**

There is a story told of William B. Smith, who for two or three years past has been salesman with W. S. Taylor & Son. Mr. Smith is one of the best salesmen in Utica, and he enjoys as thoroughly as anyone, the tale which is told at his expense.

Messrs. Taylors' landlord was about to remodel the building occupied by them, and this made a removal necessary. They therefore decided upon an auction sale, to dispose of some of the older stock, and engaged Col. Rutherford to conduct the auction. The sale was well attended, and in his own style the Colonel was impressing contemplating purchasers with the immensity of the bargains offered. One old lady insisted on having a dozen spoons "made by Mr. Rogers." Colonel Rutherford informed her that Mr. Rogers had gone on beyond, but that the business had been bought by the Meriden Britannia Co.

Mr. Smith, who was then new in the business, seized this pointer with great avidity and lost no opportunity for springing it. One day a boarding house keeper came in to buy some spoons. She wanted the cheap, steel sort, which sell at something like a dollar a barrel. Mr. Smith was equal to the occasion, and told her the firm had them, in genuine Rogers' ware.

"You know Mr. Rogers is dead," he assured her, suavely, "but we call these Rogers' make, you know. You see, the business was so great that it could not be allowed to suspend. A dozen? Yes, thanks. Would you like them engraved with your initials or monogram? Our Mr. Payne will

engrave them for you. Call to-morrow. Good-day, madam."

Mr. Payne is still endeavoring to learn the art of engraving steel spoons, silver plated, without cutting through to the black metal. In the meantime, the genial and courteous Mr. Smith is still telling patrons that Mr. Rogers is dead.

This reminds one of the experience Mark Twain relates in "Innocents Abroad," when in Italy. The guides were continually pointing out busts and statues of Christopher Columbus, and finally Mark inquired, solemnly, "Is the gentleman dead?"

*Eugene J. Pugh*

UTICA, N. Y.

**Sam Rush's Hunting Trip.**

Samuel Rush, of Rush & Smith, Mt. Carmel, Ill., recently joined a jolly party of three and started for a hunting trip into the wilds of Arkansas. In a few days his Mt. Carmel friends received a letter full of enthusiasm regarding the big game he was killing—deer, etc.; but the next day Sam suddenly appeared at home and was strangely silent as regards his trip.

This greatly mystified his friends, until it leaked out that Mr. Rush and the party were arrested in Arkansas for hunting without a special permit and fined \$12.50 each. Between the four brave hunters \$20 was paid the officious sheriff, who consented to wait until the next day for the balance of the fine. In the quiet hours of the night the crest-fallen hunters boarded



a home bound train, determined that the balance of that fine should never be collected.

After arriving safely home Mr. Rush made numerous inquiries and learned that there was no such hunting law in the State of Arkansas, and that the stern and awful sheriff was only a harmless practical joker, who expected to return the \$20 when the hunters came to pay the balance of their fine. It is not yet safe to mention this hunting trip to Samuel Rush.

*Helen M. Hinney*

INDIANAPOLIS, IND.

**A Romance of Moving Day.**

It was moving day for one of the firms on Jewelry Row in the Modern Athens. Floyd, Pratt & Co. were about to whisk themselves and all their goods and chattels around the corner to chambers on Summer St., and all

the jobbing houses on Washington St. were interested in the event. Up and down the thoroughfare the surging throngs of shoppers passed and repassed, and self-constituted sidewalk committees superintended affairs.

Out came great sections of counters, showcases and safes. The crowd gazed with unusual curiosity, for was it not a jewelry concern that was moving? When the movers swung some of the things from the windows and lowered them to the sidewalk, star-gazing was the popular pursuit of half the pedestrians.

Along came a pretty maiden. She had a Paris hat on her graceful head, a New York rolled umbrella in her dainty hand, and a Boston pair of eyeglasses athwart her aristocratic Grecian nose. Following the precepts of Rev. Dr. Edward Everett Hale, she looked "up and not down," and found herself the next moment clasped in the embrace of a fashionably attired young man, who was wrestling with an icy bit of pavement that threatened to throw them both.

Being something of an athlete the youth managed to retain his balance. He was about to tender profuse and abject apologies for his absent-mindedness in imagining that he was a drowning man and the fair damsel the only straw that he could clutch at for safety, when their eyes met.

"Charlie!"

"Eva!"

Whereat the bystanders laughed, and all the clerks and salesmen who had been watching proceedings from the windows of the other jobbing houses wished they stood in Charlie's shoes.

As Charlie offered his arm to Eva, faced about and retraced his steps with her, you wouldn't have thought to look at them that there had been the most irreconcilable of lovers' quarrels, with these two for participants, just 48 hours previous.

Since then I have received a card that reads somewhat as follows:

CHARLES STUART DIAMOND  
 MISS E. ADAMS RUBY  
 Married  
 Wednesday, January Thirty-first,  
 1894.  
 At Home  
 After February Twenty-eighth,  
 Emerald Street,  
 Suburbia,  
 Massachusetts,  
 1894.

*John S. Browning*

BOSTON, MASS.

**An Incident to Mr. Pitts.**

Every one in Montreal and Eastern Canada, connected with the jewelry trade knows James A. Pitts, wholesale jeweler, in the Temple building, Montreal. The past Christmas season was a busy one with him and although Mr. Pitts weighs something over 200 pounds, he got around the city in an



ALL KINDS

FANCY WOOD

CHESTS

FOR

TEA SETS

AND

FLAT WARE.



FANCY KID,

CHAMOIS,

SILKS and

BROCADE

CASES,

FOR

SILVER WARE

AND

JEWELRY.

**HEBBARD & BROTHER,**  
**860 BROADWAY, NEW YORK.**

“THE BEST BUTTON MADE.”

IN GOLD

FROM

**KREMENTZ & CO.**

AND ALL JOBBERS.



IN ROLLED PLATE

FROM

ALL JOBBERS.

COLLAR BUTTON.

THE ORIGINAL ONE PIECE BUTTON.

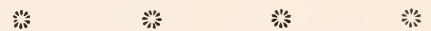

STILL THE BEST AND STILL UNSURPASSED.

PATENTED AND PATENT SUSTAINED BY U. S. SUPREME COURT.

# New Novelties In



## Silver Plated Ware.



COLUMBUS BERRY FORK.



VICTORIA BUTTER SPREADER.



COLUMBUS OYSTER FORK.



COLUMBUS ORANGE SPOON.



CROMWELL ORANGE SPOON.

MANUFACTURED BY

# THE Wm. ROGERS MFG. Co.

OFFICE AND SALESROOM, HARTFORD, CONN.

FACTORIES:

HARTFORD, CONN.

NEWBRIDGE, CONN.

TAUNTON, MASS.



astonishingly quick manner. In order to facilitate business he employed cabs to some extent. At this season of the year, too, cabling has its advantages besides speed, considering the slippery condition of the streets and if there is anything that J. A. P. has a dread of, it is doing involuntarily the skirt dance on the streets of Montreal. One day he hired a covered sleigh and started on his rounds with many parcels.

"Drive sharp, Jo," was the last injunction he gave the driver as he closed the glass door of the vehicle. Jo drove the old nag of his as only a Montreal Jehu can, and at every corner they turned the vehicle slewed in an alarming manner and the runners described wonderful curves in the roadway. At McGill and College Sts., the equipage was performing its usual street evolutions when the whole institution suddenly turned over, horse, driver, Pitts, parcels and all.

The Jehu jumped off his box in the descent but our hero was somewhere inside of the rig and for a few moments was hardly aware of what had happened. It did not take long for him to make up his mind to find out and as the doors would not open he proceeded to cut his way through the debris. Having reached the air Mr. Pitts rested for breath. For a few moments he stood knee deep in cab debris with a parcel in one hand and a sample case in the other, hat off, coat torn and mad. The phoenix rising from its ashes was nothing to Pitts rising from that wrecked cab. The tableau was charming but somehow James A. did not acknowledge the shouts of admiration from the crowd, and saying something unrecordable, hailed another cab and went home.

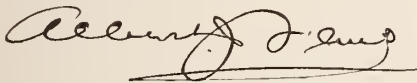

MONTREAL, CAN.

#### Mound Builders as Jewelers.

Edward Butts, formerly city engineer at Kansas City, and an earnest student of American archæology, possesses three unique specimens of the prehistoric jewelers' handiwork of more than usual interest. They are two earrings and a cross. The earrings are crescent shaped and the band is fastened to the body by an ingenious hinge. Both the earrings and the cross are made of hammered silver, and are ornamented with rude tracings much resembling modern engraving. The cross is three inches long and has two arms. It shows the marks of the beater's mallet, and it is to be inferred was not worn as an article of personal adornment, because it has no ring by which it could be suspended.

The jewels were found buried in a mound at Edwardsville, 16 miles from Kansas City. This mound was one of a group and corresponded in general appearance to others in the Missouri Valley and accredited by experts of the Smithsonian Institute with belonging to the age of the Mound Builders. Trees several centuries old stood on the

mound where the jewelry was unearthed. A double cross similar to this one was found some time ago at Danville, Ill. Mr. Butts has been unable, as yet, to discover its significance. The earrings were, of course, for personal adornment. Their counterpart has never been discovered.



KANSAS CITY, MO.

#### And He Never Came Back.

An incident which furnished amusement for a large number of people and relaxation for the ladies and gentlemen connected with the store of L. Sunderlin & Co., occurred recently in front of that establishment. A member of Rochester's select circles drove up in state to Sunderlin's for the purpose of having some diamonds reset. When she spread the gems out upon the counter, one stone was missing. Consternation immediately seized upon her, and the frills and furbelows with which she was encumbered never underwent a closer inspection than upon this occasion. The search extended to sidewalk and brougham, the latter being denuded of its trappings in the quest for the treasure. The passing crowd caught the anxiety betrayed in the countenances of the investigators, and in a few moments a surging mass of people of all shades and conditions was earnestly engaged in the chase.

About this time one of Mr. Sunderlin's young men, a horologist by profession and a wag by inclination, conceived a plan for extracting some fun from the situation. Taking a "sparkler" from his bench he rejoined the searchers and when opportunity offered slipped the bit of glass into a pile of dirt. In less time than is required to tell the story an old man, shabbily clad, approached this particular pile of earth, and the treasure was his. The look of supreme joy which overspread his countenance, and the celerity with which he broke through the crowd and disappeared, shamed the air of decrepitude which lingered about him. And he didn't return the gem to its rightful owner, either.

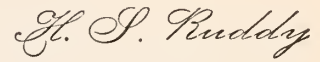

ROCHESTER, N. Y.

The several other correspondents of THE CIRCULAR had interesting incidents to relate, but as we have illustrated some of the idiosyncrasies of the jewelry trade, and the space for the many special articles of this Silver Anniversary Number is already too limited, we will call a halt, hoping that these Stories by THE CIRCULAR'S Correspondents, which will be in evidence in THE CIRCULAR from time to time, will prove entertaining if not particularly instructive.

THE EDITOR.

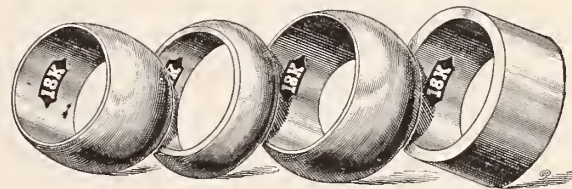

Band rings, metal lapped. Full value allowed for old gold.

**PLAIN SOLID GOLD RINGS.**  
**HILDRETH MFG. CO.,**  
**53 MAIDEN LANE, NEW YORK.**

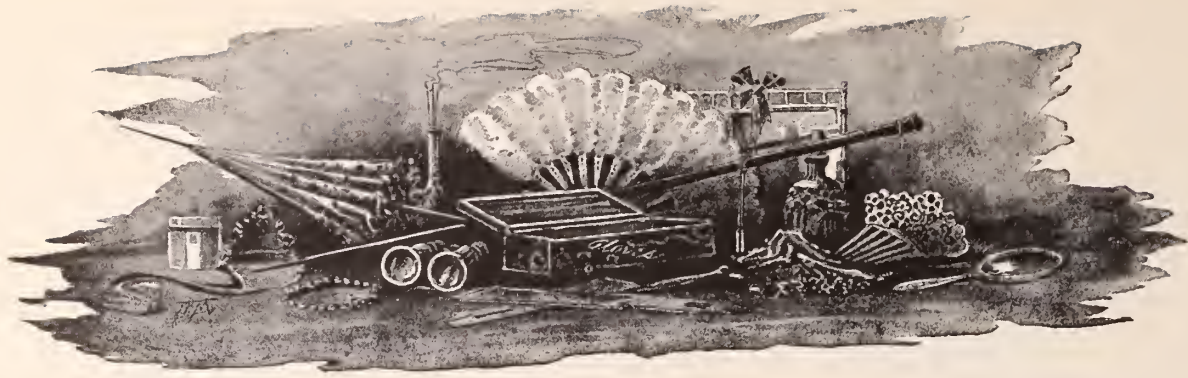

## THE KINDRED LINES OF THE JEWELRY TRADE.

THE ADVANTAGES TO JEWELERS IN HANDLING LEATHER GOODS, ART POTTERY, CUT GLASS, TORTOISE SHELL GOODS, BRONZE ART GOODS, ETC.

The relations to the regular jewelry business of those classes of merchandise known generically as kindred lines, have essentially been effected during the past quarter century. These lines are no longer considered in the light of ventures, but are absolutely necessary in the ensemble of the complete jewelry store. They harmonize in their artistic attributes with the delicate products in the precious metals and gems, while they add beauty to the establishment and yield a good measure of profit. The following brief essays by gentlemen versed in their own particular lines, will give jewelers generally many positive ideas which will redound to their advantage.

### ADVANTAGES OF LEATHER GOODS.

Until ten years ago nearly all the fine leather pocketbooks used in America were of European make. The workshops of France, Austria and Germany supplied the trade. But the quality of the imported goods was low and the workmanship not of the best, and our people demanding articles superior in style and finish called on native manufacturers to supply the want. Now American workmen and American workshops are producing goods far superior in style, finish, strength and utility than were ever made abroad.

In the earlier days leather goods were carried in the stocks of dry goods dealers exclusively, but as the demand for a higher grade of articles became more marked, and as the dry goods dealers do not care to keep in stock such expensive wares, the natural result was that live jewelers throughout the country, recognizing that fine leather goods were certain to be a valuable adjunct to their business, bought small lines that cost from \$100 to \$350, and gradually worked up a trade which has developed into a positive business.

A fact which impresses itself on the mind of an observer is that once a woman possesses a pocketbook or card case of fine leather and made in a stylish and sensible manner, she will always want the like. The jewelers will thus be frequently called upon to supply the demand and will eventually

find the leather goods department a growing as well as a profitable one.

The great variety of material and the still greater variety of ornamentation place the retailers in a position to satisfy any customer's wants, no matter howsoever fastidious. As a medium for affective window dressing, no line of goods offers better opportunity. The black and white, snake and lizard skins, and the English, morocco and dentelle leathers in their fancy shades, invariably produce a highly attractive effect.

*Carl J. Weitsch*

### HINTS ON SELLING ART POTTERY.

Art pottery belongs essentially to the commercial domain of the jeweler, though he does not control the sale of these goods. Other dealers handle these goods, but inasmuch as art pottery is only an adjunct to a jeweler's stock and people would rather purchase this class of ware from jewelers than from other merchants, they could materially increase their business in this line by paying particular attention to two methods of making sales.

The first method is to effectively display the ware. Watches, diamonds, clocks, rings and pins and other jewelry *ad infinitum* are displayed day after day, week after week, but seldom is a window devoted exclusively to a display of art pottery. A half dozen pieces well displayed on a ground of plush or velvet will do more to attract attention than 50 pieces set on a shelf. The beautiful features of the ware commend it at once to the appreciation of the passer-by, who will never forget the display, and who, when intending to make purchases will think first of that jeweler whose display was impressed upon his mind most favorably. Not only should art pottery be well displayed in the window, but it should be also shown to advantage within the store. An intending purchaser will be more impressed with a handsome vase set on a pedestal or a plush covered table than on a bare shelf at

the rear of the store. The customer may also buy the pedestal or the table. The displaying of art pottery is almost an art in itself, and too much care cannot be expended in its study.

The second motive power in making sales lies in daily newspaper advertising. Jewelers do comparatively little advertising. When they do advertise their announcements occupy a few inches, before Easter and before Christmas. They then consider their obligations to printer's ink are fulfilled. They make little or no mention of art pottery in their advertisements, notwithstanding the fact that there is a large profit in handling it compared to the profit on the standard makes of watches or clocks they advertise prominently. Continued advertising of art pottery is sure to increase its sale, and there is no more reason why a jeweler should advertise only ten or fifteen days in the year than there is in keeping the store open for the same length of time and closing it the balance of the year.

*George S. Lemery*

### HOW TO HANDLE CUT GLASS.

It cannot be denied that cut glass has loomed up prominently in the best jewelry stores during the past few years, and it has come to stay. The jeweler cannot now, without loss of prestige and of trade, confine himself strictly to gold and silver wares. Cut glass has the advantage of being artistic, beautiful and useful, and no store is so richly furnished or carries so fine a stock but that a line of cut glass will enhance the beauty of the store and help to increase the sales.

Unlike silver ware, cut glass does not require polishing or refinishing when not in use. It does not fade nor tarnish when exposed to air, and requires only intelligent protection to enable it to be always fresh and bright. It should not be held with moist hands and then put down uncovered and exposed to dust, as a scum will form on the surface, the bright polish will be dimmed



and the brilliancy and luster disappear. In such a case it would be as well to have pressed or molded glass.

Cut glass should be displayed on glass covered tables, or in glass protected cases; it should be wiped and brushed at frequent and regular intervals. In dull seasons, once or twice a year it may be washed with soap and water, dried in sawdust and then brushed clean. No matter how old a piece may be it will then look as bright and fresh as when new. Glass exposed upon open tables, or upon shelves, requires daily cleaning and brushing, and being handled often and being within the reach of careless shoppers, soon shows wear and tear in broken points and scratched surfaces.

*Wm. J. Dooling*

#### POPULARITY OF TORTOISE SHELL GOODS.

**T**HE embodying of tortoise shell in hair ornaments is rapidly increasing. Enterprising jewelers recognizing the importance of keeping pace with the times, are ordering selection packages, making attractive window displays and acquainting their customers with the merits of this line. As every improvement or innovation usurps to a greater or lesser extent the position of its predecessor, so tortoise shell hair ornaments are actively rivaling those of gold and silver for first place. The reason is obvious. Tortoise shell does not cut the hair, which metal is likely to do, and weight for weight it exceeds the value of silver and nearly equals that of gold, while its extremely light weight combined with its refined and elegant appearance makes it particularly adaptable as an ornament of the coiffure.

The style in greatest demand is the Spanish or high top ornament, both plain and carved. It produces an effect at once elegant and distingué. A novelty in this line is a tortoise shell hair ornament embellished with electro-deposit silver filigree work. As yet this style has not been made in quantities, but the demand is extensive.

No stock of tortoise shell goods can be considered complete without an assortment of lognettes. Their extremely light weight makes them universal favorites. They may be obtained with either plain or carved handles. To jewelers who do not carry a line of tortoise shell goods, it will prove interesting to them to know that they can obtain an assortment for \$50 and upwards. Displayed in his window on a covering of cream, or any other appropriate shade of satin or velvet, the jeweler will find this line a means not only of increasing the number of his customers, but also of disposing of a larger quantity of his goods.

*Ignatius Rice*

#### TO COUNTERACT UNFAIR COMPETITION.

**I**T is a well-known fact, that nearly all the large dry goods stores run a jewelry department. In it we find not only the nickel clock from Connecticut, and the stamped, gilded, soft soldered breast and scarf pins from our most cultured down east State, but also diamond jewelry of fair quality, American watches (movements at jobbers' discounts, and cases sold at so much per penny-weight), onyx clocks of dubious quality, and eight-day clocks marbled, 1/2-hour gong strike, with real bronze ornaments for \$2.98. The dry goods clerk will also show you 4-ounce solid and hollow ware and rattle off discounts at which the jeweler could not buy, unless Safford had his credit at: Good for all requirements.

These are facts. These are the conditions of to-day. How to cure these abuses? Well, I individually, am waiting until the jeweler is ready to help those who are only too willing to help him in this fight.

The wide-awake jeweler, many years ago, extended his lines, adding to his stock leather goods, umbrellas, cut glass, and now most judiciously selected bric-à-brac—vases of Royal Worcester, Limoges, Sèvres and Saxony, unmounted or mounted in gilt or real bronze, chime clocks, pedestals, hall clocks, cloisonné sets, baccarat, étagères, liqueur caves and what-nots, mirrors, lamps, Russian silver, etc. No large stocks of some of these lines have been imported, but still fewer have been sold. But this condition is all right. The wise jeweler knew it was 1893, an off year, with more business for Bradstreet than for him. He wisely bought lots of small stuff—bric-à-brac that he could offer at three or five dollars. This added to his line, his sales and his profits.

When Congress adjourns and the senators are sent home there will be better times for the jeweler's counter and bench. But I advise the jeweler to extend his lines, to make up for what has been taken from him.

*J. Krober*

#### THE APPROPRIATENESS OF FANS.

**F**INE fans are a necessary adjunct to a jeweler's stock. During the Winter months, when balls, receptions and afternoon teas are the vogue, the demand for these goods is at its height and jewelers should be on the lookout to receive their share of business. The only way to increase sales in this department is to keep a representative assortment in stock. Fine fans are staple goods, their value does not depreciate; a fair assortment costs but a moderate sum, while for display purposes they are unequalled. A jeweler who keeps but a few fans in stock cannot hope to dispose of a large quantity. Women are the purchasers of fans, and everyone is aware of their desire to select from a wide assortment. The fan line pre-

sents to jewelers an opportunity to work up a good trade, and a very pretty assortment can be bought for one hundred dollars.

The Empire fan with its covering of delicate silk gauze, its decoration of small figures and white bone sticks inlaid with silver and gilt, is becoming very popular. Its price is very modest costing, but \$2 and upwards each. The lace fan with flowered decorations, and bone and pearl sticks is a style which has always sold well with the jewelry trade. These goods are shown by some of the best retail stores priced as high as \$100 apiece. Many effective and pretty styles can be sold from \$5 and upwards each.

Ostrich feather fans are sold usually either in white or cream with bone or wood sticks and in black with shell or ebony sticks. This line is a desirable one for jewelers to handle as its value never depreciates. They may be retailed for \$5 and upwards.

It will be inferred from the foregoing that jewelers need not carry a large variety of styles in order to compete with other houses. The essential item to be observed is to carry enough of the styles displayed so as to be able to assure intending purchasers that the stock is extensive enough to select from.

*E. Davidson*

#### Tragedian Keene's Curious Ring.

**T**HOMAS W. KEENE, the tragedian, wears a ring on the second finger of his left hand which is causing him no end of worry. During his engagement in San Francisco this ring was sent to him by several friends and he wears it more particularly during his impersonation of Richelieu, as he regards it as most fitting to that character. However, it is not the wearing of the ring that perplexes Mr. Keene; it is the peculiarity of its design and the mystery that surrounds the origin of the ring.

Evidently it one time belonged to a bishop. In the center is a rose colored carbuncle, and surrounding this is a perfect horseshoe of diamonds. The carbuncle itself is one of the most brilliant and rare in existence. At the bottom of the ring is a bishop's mitre made up of sapphires and rubies. The whole is surmounted by a crown, also composed of diamonds, pearls and rubies of pigeon blood hue. The ring undoubtedly came from Mexico, and had been stolen. The gold is battered and worn, and the strongest caps hold all the jewels secure. Mr. Keene would give a great deal to find out the origin of his present, and penetrate back to the days when it must have flashed terror from the hand of some monseigneur of the church.

'O, pal,' said the topaz to his fiery friend, 'I noted that you quaffed rather copiously of the ruby last night.' 'Don't you talk,' replied the opal; 'you were always among the toppers.'



**SPRING**  
1894  
**Announcement.**

OUR IMPORTATIONS OF NEW SAMPLES FOR THE COMING SEASON ARE NOW ARRIVING AND WE HAVE ON EXHIBITION AT OUR WARE-ROOMS A COMPLETE ASSORTMENT OF EXCLUSIVE

**Novelties**

AND

**Specialties.**

Selected for the Jewelry Trade.

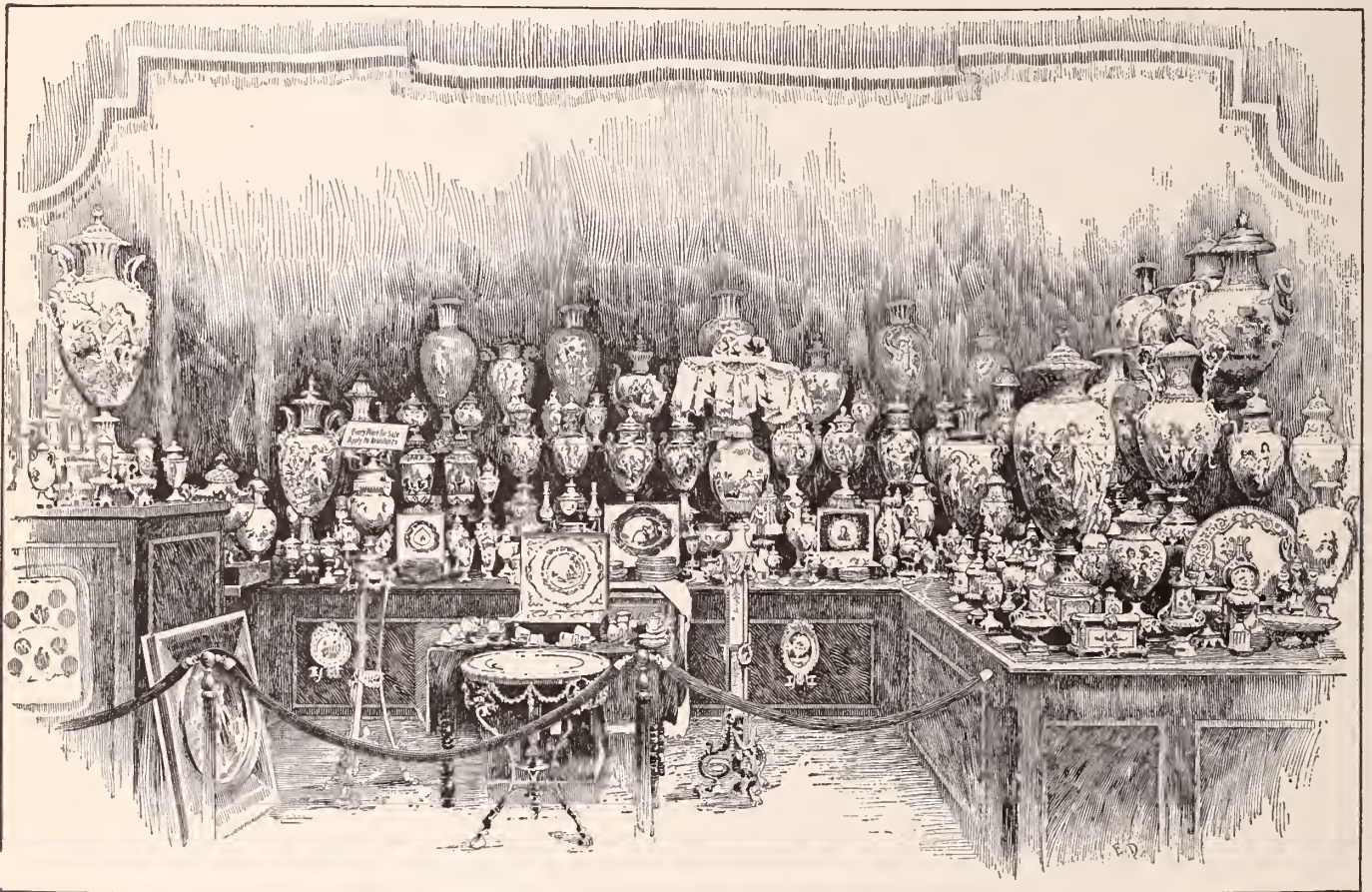

CLOCKS, BRONZES, SEVRES VASES,  
FINE DECORATED PORCELAINS,  
CUPS and SAUCERS, TEA SETS, LAMPS,  
and Photo Frames in endless variety.

**Leon J. Glaenger & Co.**

80 & 82 Chambers Street,  
New York.

ORDERS TAKEN FOR IMPORTATION.

35 Boulevard de Strasbourg, Paris.





## ARTISTIC CLOCKS IN NEW YORK'S PALATIAL HOTELS.

**G**UESTS at the new magnificent hotels in New York may keep track of the flight of time by means of timepieces that are masterpieces of decorative art. The general onward tendency of the art decorative requires the character of details to be in keeping with the general effect of the surroundings. When that effect leans

case was made after the design of the hotel architects, entirely of onyx, relieved by graceful ornaments and borders of bright yellow bronze. This clock, as well as two double dialed circular onyx clocks in other parts of the hall leading to the writing and dining rooms have electricity as the motive power.

Also on the main floor, in the handsome and luxurious apartment known as the Marie Antoinette parlor, is the dainty Empire set of which our artist has been able only to suggest the beauties. The bases of the candelabra and clock are of bronze ornamented with graceful geometrical designs. Each of the candelabra has six candle sockets tastefully dispersed among a dozen lilies with gilded calyxes and stamens. On the left Cupid clashes a pair of cymbals, while his companion marks time with castanets. Supporting a globe, enameled in dark blue, star studded and disclosing the dial figures, is another pair of Cupids, also depicted in the act of producing music with pipe and cymbals. Resting on the globe are a mandolin, horn and other instruments of music. The hands are formed of an engraved snake coiled in the centre, the tail serving to mark the minutes and the head the hours.

Another engraving of a clock at the Waldorf depicts a timepiece in the state suite. The case is of an East Indian wood, hand carved. It served to mark the hours for the Duke de Veragua during his recent visit to New York as the guest of the city. Also in this state suite is an antique Dutch hanging clock of brass, with quaint dial and case, the pendulum being an anchor and the escapement one which served the purpose when an error of ten or fifteen minutes each day was a matter of no consequence. To-day, unfortunately, it does not go at all.

In the various ante-rooms and parlors of the state suite are numerous other clocks of faience and in Empire style, and mention should also be made of the china in the dining-room connected with the suite. Contained in the seven cabinets upon the walls are dinner services of hand painted porcelain intended only for the use of royalty visiting these shores. Portraits of all the crowned heads are shown on the plates and plaques, and the visitor's only regret is in the thought that this handsome china will be but little used.

At the Savoy Hotel is one of the most artistic clocks in the city. Once the property of John Hoey, it occupied for many

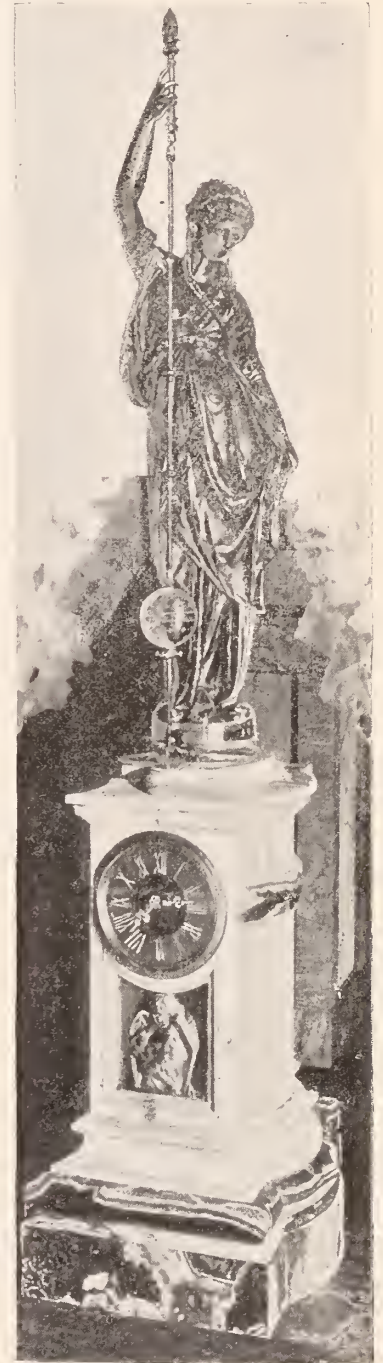

HOEY CLOCK AT THE SAVOY HOTEL.

years a place of honor at his Hollywood mansion. Purchased at the sale of Mr. Hoey's art collection by the owners of the

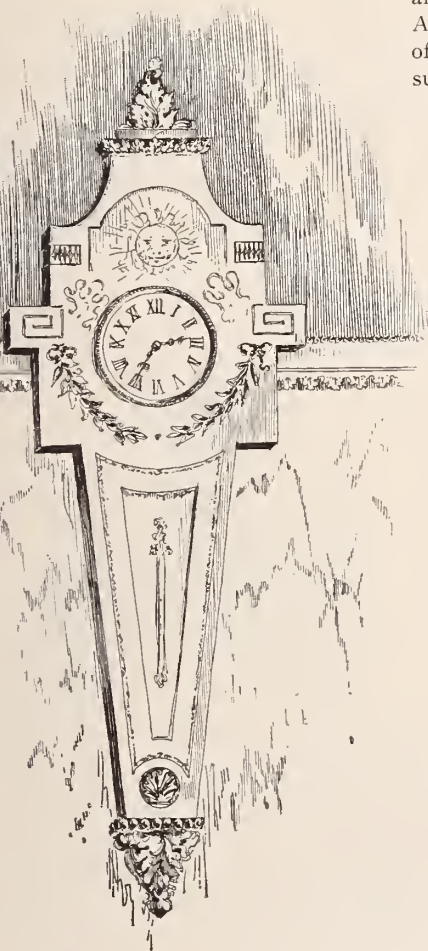

CLOCK IN MAIN HALL, WALDORF HOTEL.

toward the sumptuous, the timepiece, therefore, even in the public room of the hotel must possess artistic as well as time-keeping qualities.

Perhaps in no hotel have clocks received as much attention as at the palatial Waldorf. Here each clock or clock set is as much a part of the furniture as the tables or chairs, harmonizing in each case with the general effect.

In the main hall, directly opposite the clerk's desk is the handsome onyx and bronze clock illustrated herewith. The

# THE F. KROEBER CLOCK CO.,

360 BROADWAY, 1894 NEW YORK.

MANUFACTURERS AND IMPORTERS.

HALL CLOCKS,  
 CHIMES,  
 CLOISONNE CLOCKS,  
 FAIENCE CLOCKS,  
 GILT and PORCELAIN  
 SETS,  
 CANDELABRA,  
 PEDESTALS,  
 SEVRES VASES,



PORCELENE CLOCKS,  
 DRESDEN TRAYS,  
 HUNGARIAN TRAYS,  
 CABINETS,  
 ONYX and MARBLE  
 CLOCKS,  
 FAIENCE GROUPS,  
 EUROPEAN ART  
 GOODS,  
 BRIC-A-BRAC.

WE MANUFACTURE THE LARGEST AND MOST ATTRACTIVE LINE  
OF AMERICAN CLOCKS.

# ROGERS, SMITH & CO.

UNION SQUARE,  
 NEW YORK.



MERIDEN,  
 CONN.

BEST QUALITY

# GOLD AND SILVER PLATE.



Savoy, it now stands in the hall on the ground floor of that hotel, to the left of the hotel desk. From the floor to the tip of the pendulum rod in the right hand of the figure the distance is nearly 11 feet. The base is of polished rich brown variegated marble, supporting a white marble pillar, flattened in front, which serves as the case. On this rests a bronze female figure, in graceful drapery, whose upheld right arm holds a swinging rod, having near its lower end an enameled dark blue ball and terminating in a fine point which engages with the escapement. A circular motion is thus imparted to the rod and ball, causing the latter to swing slowly round its allotted orbit. At the equator of the blue sphere, typical of the heavens, are the signs of the zodiac in bronze, while numerous gilded stars stud its other portions. The extreme point of the rod marks the seconds as it swings round a bronze circle beneath it. A bronze Cupid, in bas-relief,

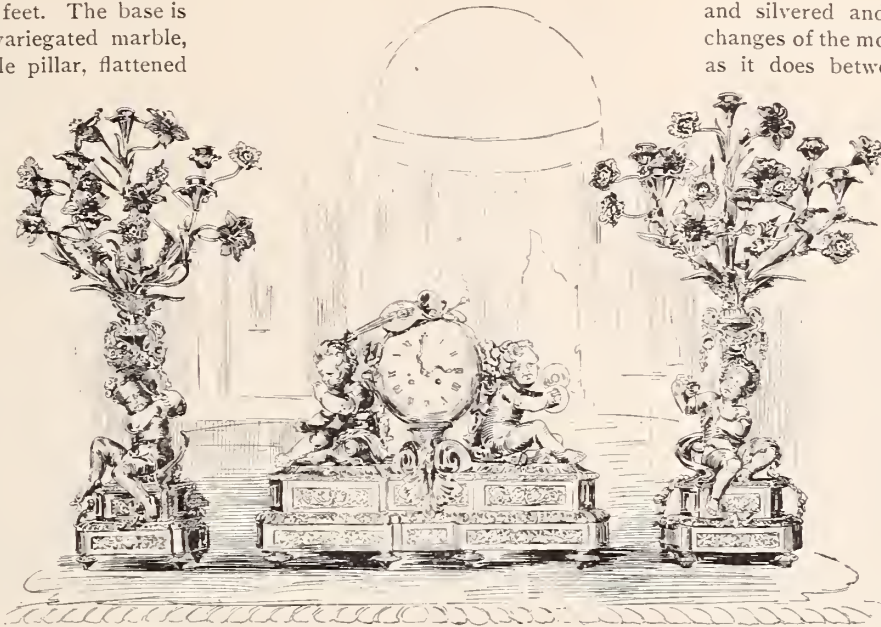

MARIE ANTOINETTE SET AT THE WALDORF HOTEL.

by a terrestrial globe and flanked by a telescope and an allegory of History was a particularly happy coincidence, in that it

minutes by chiming at the quarter hours. The case is of oak, very highly polished and relieved by trimmings of wrought iron in dull black finish. The dial is handsomely gilt and silvered and above it are shown the changes of the moon and the date. Standing as it does between two handsome pillars of polished marble, the general effect is one of extreme richness.

Not many of the guests at the Holland House as they note the time by the handsome clock in the main hall are aware that it keeps in order the one hundred and twenty other clocks in various places about the hotel. This is done by an electric system specially designed for interior use.

The main or master clock already referred to has an eight day movement, manually wound, and by means of ingenious electrical devices not only imparts

told the time to the Princess Eulalia during her visit to this country last Summer. It stands in one of the hotel parlors, which formed part of the suite occupied by the Princess during her sojourn at the Savoy. Coming as she did to visit the continent which owed its discovery to Columbus, she had before her a clock reminiscent in its ornamentation of the navigator who sailed from Palos toward the west over a trackless ocean.

motion to the other clocks but effects synchronization either backward or forward every 15 minutes. In all the secondary clocks, the minute hand of course jumps from one minute to the next at one motion. These secondary clocks vary in size from 12 inch wall dials to 4 inch dials in onyx cases in bedrooms; a particularly agreeable feature of the latter, to

The globe is symbolical of Columbus' idea, the laurel wreath of him who discovered the Americas, while History with waiting fingers, ready to write the discoverer's name on tablets of enduring bronze. On each side of this clock stand two branched candelabra on square pedestals, bearing miniature incandescent electric lights in globes of ground glass.

At the Plaza, our artist photographed the clock in the main hall, to the right of the hotel offices. The case is of carved mahogany, with side panels of embossed velvet, and the dial is about 11 feet above the floor.

Chimes mark the hours and quarters. Beneath the clock our illustration shows the hotel stenographer, a prettier girl by the way than the camera seems to show. In the parlors on the floor above are also two very pretty clock sets, one of French and one of American make.

The Imperial Hotel has a handsome clock facing the clerk's desk

on the main floor. It occupies a position at the lower landing of the main staircase elevated slightly above the floor. It is particularly commended as an excellent timekeeper, beside marking the fleeting



EMPIRE CLOCK AT THE SAVOY HOTEL.

nervous people, is the fact that they are noiseless. Any one of the secondary clocks may be lifted from its base without disturbing the other clocks in the circuit.



CLOCK IN THE STATE SUITE OF THE WALDORF HOTEL.

below the dial, typifies the flight of time by means of an hour-glass.

The dainty little Empire clock surmounted



There are many other hotels in New York with clocks well worthy description, but the

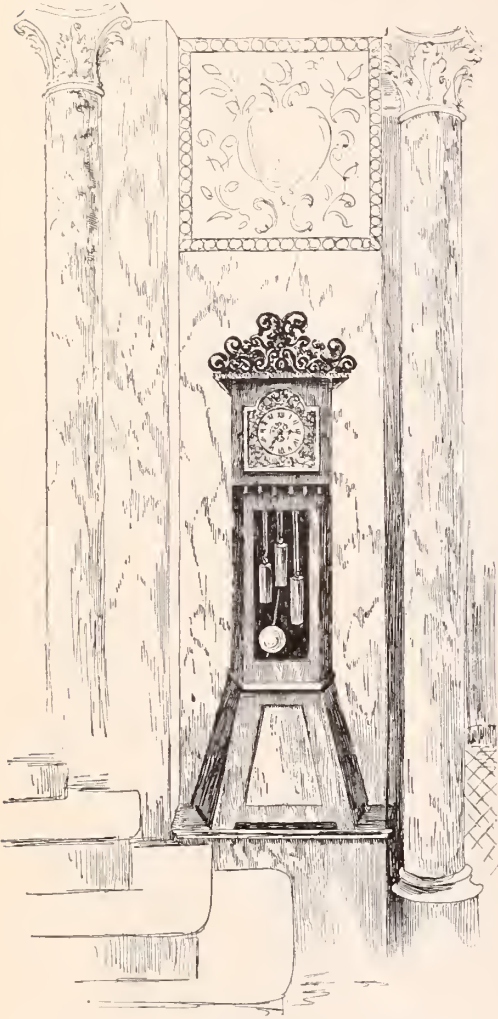

CLOCK IN THE CORRIDOR OF THE IMPERIAL.

limits of the present article make it impossible to do more than sketchily describe the most interesting.

*Richard H. Keller*

#### THE HOUR'S WOODEN LEG.

SEVERAL thousands of pounds were paid for one wooden leg provided by the Sultan of Turkey for a favorite of his harem. Having lost her leg in an accident, the Sultan had an artificial one of wood made for her, and by his directions it was set with rare and costly jewels to the value of many thousands of pounds. When released from its position each night this jeweled limb is guarded with great care, and restored to its fair owner when she rises in the morning.

"I'm tired of working" said the hall clock. "So'm I," replied the regulator. "Let's strike!" offered the first. "No, let's wind up our affairs," suggested the second.

#### Through the Vista of Past Fashions.

LOOKING back through the glittering, dazzling vista of 25 years' fashions in jewelry, one might easily ask, "Can there be anything new 'neath the sun?" Indeed, it would seem as though Nature's resources and the jewelers' ingenuity had been taxed to the utmost; yet the jewelers' skill has never before reached such a state of perfection as to-day, the increase of the use of precious stones has never been so great. This is particularly true of our own country. Foreign authorities in such matters receive with open and welcome hand, our many original designs in stone settings and silverware and the superb displays made by the jewelers and silversmiths of America, at the World's Columbian Exposition, opened the eyes of European visitors.

The feverish eagerness among American women to amass jewels has been most noticeable during the past twenty-five years, and so great has the desire for precious stones become that now-a-days a woman of moderate wealth can boast of a collection of jewels that a woman in the same circumstances of life a quarter of a century ago hardly dreamed of possessing.

Those were the days of golden glory and ladies of fashion were contented if their jewel boxes contained a handsome assortment of gold ornaments. Jewelry was designed in gold in all its various shades and qualities. The styles were both massive and delicate, although the massive style was more popular. All ornaments were sold in sets; earrings, brooch, necklace and bracelets, to be quite in the mode, must all be of one design, in direct contrast to the prevailing style of to-day, when only that which is the most "unique" is desired, one frequently finding a solitaire sapphire screw worn in one ear with a solitaire ruby in the other. The earrings of '69 were very large, very long, and the more showy the better.

A recent peep into a jewel box of 25 years ago, brought to light a most curious design in earrings, namely, a horn of plenty made of filigree gold, long enough to almost reach the shoulder, and thickly encrusted at the opening of the horn with precious stones of almost every variety. Although at first glance one trembled for the wearer's comfort with the somewhat overpowering looking ornament dangling from her ear, upon taking it in the hand it proved to be very little heavier than the solid gold ball earrings that afterward became so popular. Mosaics were also worn about this time and some were marvels of artistic workmanship. The big, gold linked chain, from which

hung an enormous gold locket, was the only necklace worn, while the narrow "glove band" bracelet of gold fitting tight to the wrist was considered indispensable to the toilette. Ladies in those days thought sapphire or emerald rings, set with diamonds, and worn on the first finger to be "quite the thing." Pearls were the favorite stones, become so perhaps, by the famous necklace owned by the Countess Dudley. This necklace was composed of a rope of pearls which went six times around the neck, each pearl being so absolutely perfect that six or eight would have realized a small fortune.

About the year '73 our women adorned themselves in truly barbaric splendor. No woman or young girl was happy unless her arms were literally weighed down with bangles, her waist girdled with a silver chain from which hung the chatelaine with its numberless attachments, while her neck was tightly encircled with a silver "dog collar." These silver fancies were certainly becoming, and remained popular for several years.

About this time the Princess of Wales adopted sapphires and they reigned supreme. In '76 ornaments were revolutionized and

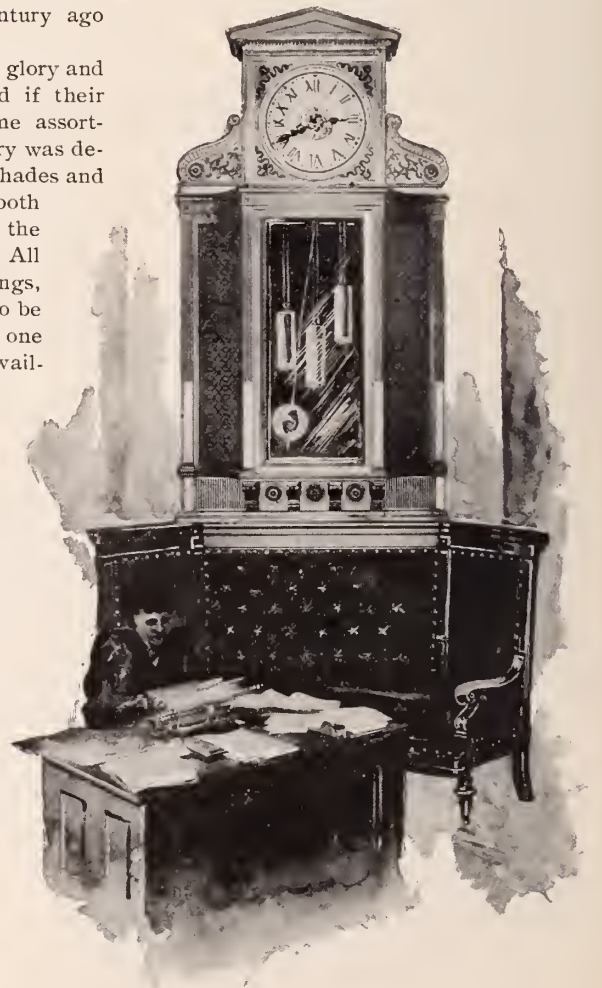

CLOCK IN THE MAIN HALL OF THE PLAZA HOTEL.

styles went back a hundred years. Platina crept into favor, instead of gold or silver, and onyx was also much worn, particularly as a setting for diamonds. The marquise ring, that has ever since remained so popu-



# THE ANSONIA.

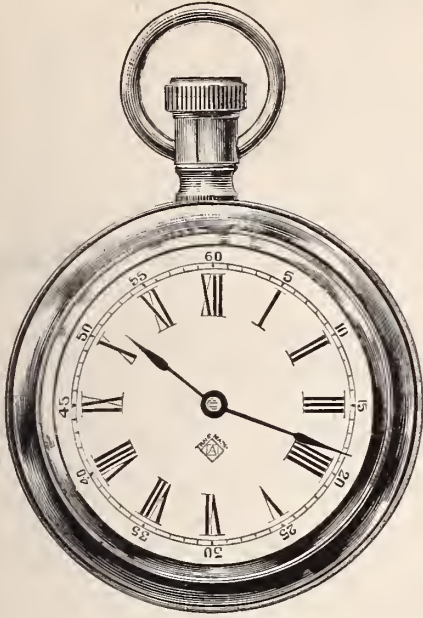

NICKEL FINISH. FULL SIZE. STEM WIND. STEM SET.

THOROUGHLY RELIABLE GOOD TIMEKEEPER. THE ONLY LOW PRICED AMERICAN MADE WATCH THAT IS STEM WIND AND STEM SET.



ADVANCE.  
ENAMELLED IRON, ONE DAY TIME, ALARM, DIAL 3 IN. HEIGHT 9 IN.



PORCELAIN D.  
HEIGHT 11 1/2 IN. WIDTH 10 1/2 IN.



ARROW.  
ENAMELLED IRON, ONE DAY TIME, ALARM, DIAL 3 IN. HEIGHT 8 1/2 IN.

To our patrons and the trade in general, we beg to announce that we have purchased the tools, machinery and all patents from the Boston Clock Company, connected with the manufacture of their fine 8 day Lever time and strike Movements, which are acknowledged to be the best of their character in the world being excellently finished, accurate timekeepers and durable.

We will add to our present lines, many new designs in metal, imported marble, onyx, porcelain, faience, etc., etc.

## THE ANSONIA CLOCK COMPANY,

CHICAGO OFFICE:  
33 & 135 WABASH AVENUE.

11 CLIFF STREET, NEW YORK.

# F. M. Whiting & Co.,

MANUFACTURERS OF

## Sterling Silverware,

NOVELTIES IN  
SILVER JEWELRY,

NORTH ATTLEBORO,

MASS.



GOTHIC.



GENOA.



RODERIC.



DAMASCUS.

READY THIS SEASON,

A GENERAL LINE OF  
**HOLLOW WARE.**

ARTISTIC DESIGNS IN  
TRAYS, DISHES, FLAT WARE, Etc.

◆—NEW IDEAS CONSTANTLY.—◆



lar, first became fashionable about the year '77, and the serpent ring at that time also made its appearance and was extensively worn by gentlemen. With their jeweled eyes or with a solitary precious gem set in its head, the serpent was a costly and alluring ornament.

Capricious fashion then flew to the Orient and Japan for its models, and in '79 curious indeed were the styles worn in brooches, earrings and ornaments for the hair. Odd little fans were worn at the throat and in the ears, and women made veritable pin-cushions of their hair with the quaint, and sometimes grotesque affairs supposed to be popular with the fascinating little Japanese maiden. Jeweled flies and bugs of all sizes and conditions were also very fashionable, and surely this style of ornament gave the designer great scope for his imagination and art.

In 1884 moonstones and tourmalines came into popularity, especially the latter, as they were supposed to possess potent charms to the wearer. Fashion, however, must have been greatly at a loss for novelties, when gentlemen wore bracelets as a leap year token, and women adopted alligator and buffalo teeth mounted in gold, as ornaments. This year was quite distinguished by the introduction of the rhinestone, which at once sprang into great popular favor, and although of slight value, when artistically and skilfully set was effective and deceiving.

Extremes went still further in 1889 and women delighted in wearing live bugs that came from South America. These very unattractive little pets were encased in a golden harness of most delicate workmanship and were fastened to the bodice by a slender

gold chain. Jeweled lizards were worn at the side of the waist. But the favorite design was the exquisite floral brooches, earrings and the stick pins that were at that time first patronized by women. The enameled effect of these floral ornaments was most charming and artistic. The style first came from Paris, but so far in advance were the effects of our own jewelers in their designs that the foreign importations were cast into the shade. The natural flower was used as a model by the skilful workman and the most marvelously faithful results were produced. Violets and orchids, with a diamond dropped amongst the petals, were the favorite designs. Tiny watches in iron cases were much in vogue at this time.

The fashions between the years '90 and '94 certainly seem as though they could not be surpassed either in design or workmanship. Never was the wearing of gems so universal. The best of the past is as much in demand as the most attractive of the present; for example, that exquisitely dainty design, borrowed from the time of Louis XV., the bow-knot. This ever popular style has held its own through all these centuries, and has been during the last three years used in almost every possible style of ornamentation although just now another fashionable fad, the dagger, stands like grim fate before it.

The latter, however, cannot stand the general usage that the charming bow-knot can, and is not likely to become so widely popular. A very pretty design is shown in silver, with a turquoise beading on the edge of the sheath and hilt. The heart design is also copied from the time of Louis XV. and

Louis XVI. This has also been widely popular in recent years and admits of great variety in style. The single and double linked hearts are in equal demand. Miniature painting on porcelain in the old French style is restored to favor, and very deservedly so.

At present the most effective design for diamonds is the sun burst, and verily no style is so appropriate to display the matchless brilliancy of this gem.

Through all changes, when every stone seems to have its day, the diamond stands alone, incomparable. In these days all stones are brought into prominence to meet the demand for variety, and such stones as the amethyst, the aquamarine, the chrysoberyl, the golden carnelian and many other stones known as semi-precious are so wonderfully cut and set as to greatly increase their intrinsic value. These stones are very fashionable just at present set in the form of collar and girdle. The turquoise has been more universally adopted in recent years than any other stone. The greatest number, and some of the most beautiful, have of late years, been found in our own country. During the past three years, \$400,000 worth of American turquoises have been used.

And the opal—that exquisite stone with its fairy light dancing over its delicate surface—just now it is finding its reward, after many years of prejudice. Indeed, so far has the old superstition regarding this stone been removed that it has become, when set in diamonds, one of the chosen stones for the engagement ring, and the woman who can claim among her associates the most beautiful opal, is to be envied not pitied.

ELSIE BEE.

## THE JEWELRY INDUSTRY OF PROVIDENCE.

THE art of making jewelry was one of the first at which mankind arrived, and the desire for personal adornment is a universal expression of man. In modern times the improved process of the art has so cheapened and increased the production of jewelry as to place within reach of everyone the ability to gratify his or her taste for it. In the United States the political conditions, together with the freer distributions of the products of industry and the activity of our social life, have led to the almost universal use of jewelry.

The chief seat of this industry is in Providence, R. I., which early assumed this position and has kept it ever since. By the Constitution of the United States a periodic enumeration of the inhabitants of the Union was provided for, but in the first of these, made in 1790, there was no record of the various industries of the country. It was in 1810 that the first report upon the manufactories of the country was submitted to Congress, and though acknowledged to be defective and incomplete, yet in the census

of this year, the jewelry manufactories of Providence are stated as employing about 100 workmen, with a production amounting yearly to about \$100,000. During colonial times there is no record that the jewelry business of this city gave any evidence of its future greatness.

Seril Dodge is the earliest jewelry manufacturer of this city of whom there is any mention. It is told that he had an establishment for the making of the shoe buckles worn by the dandies of that day, "two doors north of the Baptist Meeting House," N. Main St., which was the Westminster St. of a century ago. Sanders Pitman also engaged in the manufacture of silver at about the same period. In 1790 a committee of the Mechanics' Association, appointed to collect statistics, report that in Providence were made that year "100 pair silver buckles, 1,400 pairs plated buckles and 80 dozen silver spoons of different sizes."

The name of Dodge has been more or less prominent in the jewelry business from that day to this, and to Nehemiah Dodge may be

attributed the credit of really founding the jewelry industry in Providence. It was in 1794 that he established himself as a "goldsmith and jeweler, watch and clock maker," in a little shop on the Roger Williams estate, N. Main St. He removed nearer Market Square in 1798, a "few doors south of the Baptist Meeting House." Heretofore gold jewelry was made 18 karats fine, and being all wrought by hand, was very expensive. Mr. Dodge made necklaces, knobs and twists, gold rings and miniature cases. Knowing that trade would be greatly improved if the price of the manufactured article was reduced, he conceived the idea of introducing a cheaper class of work. Exactly what this cheaper jewelry consisted of there is no record. It is highly probable, however, that it was the system of washing or gilding which preceded the modern electro-plating. Mr. Dodge at once won success, and in 1805 there were seven firms on the list of manufacturing jewelers in Providence.

Other of the pioneer jewelers whose influence and enterprise contributed not a little



towards the growth of this country were John C. Jenckes, Ezekiel Burr, Frost & Mumford, Gorham & Bebee, Samuel Lopez, Whiting Metcalf, Jonathan B. Nichols, Galen & Arroet Richmond, Ellis Richmond, Davis & Babbitt, William R. Taylor, Joseph Veazie, Arnold Whipple, Edward S. Lyon, Pardon Simmons, Adnah Sackett, Lloyd Shaw, Christopher Burr and Josiah Whitaker & Co. In 1810 there were upwards of 100 men employed in the industry. Still the business grew until in 1812, there were about 175 workmen employed, and the value of the products during the year was \$300,000. The "last war with England" paralyzed the industry, but upon the declara-

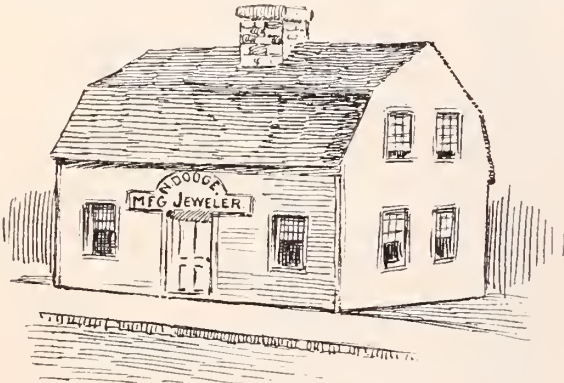

AN EARLY JEWELRY FACTORY IN PROVIDENCE.

tion of peace the jewelers took up the business where they had left off, and in 1820 there were 300 workmen engaged, and the manufactured product was valued at \$600,000. Providence contained 15,941 inhabitants in 1825 and the jewelry manufacturers had increased in the number and the magnitude of their operations.

From 1825 to 1857, the year of the great financial crisis, the jewelry business grew and prospered. Men who had commenced business with little more capital than their hands and ingenuity, in a few years owned large shops, private residences, and had good bank accounts. In those days it was the rule for one partner to preside over the shop and do more work than any of his hands, and for the other to sell the goods, do the shipping and keep the books. Industry and economy in shop expenses which characterized these early jewelers, formed the greatest source of their strength. In 1850 the business had grown to 40 or 45 shops, in which were employed about 1,200 men and boys. As an artistic sense and a steadiness of nerve were needed for a skilful worker in jewelry in those days, the right man could almost name his own wages. The result was that no other trade paid as high wages on the average.

Then, as now, the business had greater fluctuations and experienced more ups and downs than any other industry in the commonwealth. Then, as now, when it was dull it was dreadfully dull, and the people who were engaged in it declared that they were going into farming or any other pursuit rather than stay in such a delusive business.

They had served the customary apprenticeship, which was at this period rapidly growing shorter, and were generally able to do all kinds of work pertaining to the trade. When they worked they made from \$3 to \$7 a day, and sometimes even \$10, for they were generally paid by the job, and \$5 a day was not considered unusual wages.

During the first half of the century the center of the jewelry manufacturing business was on the east side, but about 1850 the shops began to move westward with the growth of the city in that direction. Instead of confining their business to North Main, South Main and Steeple Sts., their signs began to appear on the buildings of Weybosset and Broad Sts. The shops crept quietly down Eddy St., and one by one, branched off into side streets, until in the year of the panic, 1857, they had become located on Broad, Pine, Friendship, Eddy, Page, Potter, Orange and Richmond Sts., as well as upon Canal and both Main Sts. This colonization of the business in the Fifth Ward has continued until now there are no manufacturing jewelers on the east side, except a small colony at the corner of Broad and Arnold Sts. in the First Ward.

In the panic of 1857 houses tottered and fell one after another. But the reaction came and, as if to make up for lost time, the business was greatly increased. Just previous to the panic there were 56 shops; in 1860 there were 77, according to the United States census, and 86 by the Providence directory, representing a capital of more than a million of dollars. In four years 20 to 30 shops had been added; there was a generous demand, good wages were paid to employes and the outlook was roseate indeed. Then the war period came and caused radical changes. In 1864 the 86 firms had dwindled to 54. But those who weathered the gale, or who had the genius to turn the war to good account, came out wealthy. Those who had good stocks of gold on hand when it began to rise made money, while those who turned their attention to the making of cheap medals and badges of a martial character for which there was a great demand did well, and those who made brass buttons, belt clasps, and other munitions of war for the Federal or State Governments had a veritable bonanza. The period of inflation and high wages subsequent to the war was advantageous to the jewelers. They made money until the panic of 1873. Since then business has been conducted on a larger scale, but with a smaller percentage of profit, and few fortunes have been acquired.

The growth and present importance to this city in the jewelry industry cannot, perhaps, be better made apparent than by quoting some figures collected from the general and State censuses, and other sources.

In 1810 the workmen engaged in making jewelry numbered 100, and the value of the

products, roughly estimated, at \$100,000. In 1815 there were about 175 workmen, and their products were valued at \$300,000. In 1820 there were 300 employes, and they made \$600,000 worth of jewelry. In 1850 there were 729 people in the State employed in the jewelry industry, probably 700 of them in Providence; there were about 50 manufactories. In 1860 Providence county showed 77 shops, representing a capital of \$1,112,900. The cost of the raw material used was \$916,297; value of products was \$2,250,280. There were 1,498 males and 263 females employed, earning in wages \$697,692 in the year.

Five years later, in 1865, the war having done its work, and the State census being rather imperfect in this particular, there were only 45 shops reported, with a capital of \$261,000. The value of raw materials used was \$516,922; value of products, \$1,200,025; total hands employed, males 606, females 118. In 1870 there were 79 shops, but the Government census gives no statistics. In 1875 the State census reported 133 jewelry shops in Providence, employing 2,667 persons; the value of raw materials used was \$2,730,283; value of products \$6,923,551. The United States census of 1880 showed 142 shops; capital invested, \$2,755,070; value of raw materials used, \$2,495,824; value of products, \$5,444,082; wages paid, \$1,614,836; people employed, 3,264. During 1880 the 148 shops in the entire State produced \$5,650,133 worth of goods; the entire country produced \$22,201,621 worth of goods.

During the past decade the history of the trade has been a series of ups and downs. The changes in the different firms have been very numerous and an unusually large number of new concerns have sprung into existence. At the present time there are upwards of 200 firms in Providence engaged in manufacturing jewelry, giving employment to nearly 10,000 operatives, while more than 5,000 more engaged in kindred trades of enameling, engraving, chasing, coloring, etc., depend for their livelihood upon this trade alone. It is estimated that the capital invested is between \$6,000,000 and \$8,000,000 and that the average yearly output is valued at about \$10,000,000. According to the tax book the members of these 200 firms pay taxes on \$5,874,250 worth of personal property and \$10,473,650 on real estate.

The working jewelers of Providence, men and women, are as well paid and in as comfortable circumstances as the operatives of any other industry in the country. Being independent, educated and intelligent, they are a perfect type of the better class of American wage earners. Considering the number of persons employed and the wages paid them to be by them distributed among the tradesmen of the city, the manipulation of the precious metals and their alloys, forms probably the most important industry in this busy municipality. The growth has been remarkable, and its future looks prosperous, notwithstanding the depressing season just passed through.

WM. H. MASON.



# FINE AND MEDIUM PRICED WATCHES

OF ALL SIZES AND STYLES.

## SPLIT SECONDS

AND

## REPEATERS



SPLIT SECONDS.



THESE CUTS SHOW ACTUAL SIZES

RELIABLE  
QUALITY  
ONLY.



A  
complete  
line of  
**Movements**  
in various  
grades, fitting  
**American**  
**Cases**  
of all sizes.

GENUINE FINISHED WATCH MATERIAL FOR  
AGASSIZ & LONGINES MOVEMENTS.

# A. Wittnauer, 19 Maiden Lane, New York.

SOME OF THE NOVELTIES

MADE BY

# S. COTTLE CO.,

JACKSON BUILDING,

UNION SQUARE, NEW YORK.

MAKERS OF

DIAMONDS, FINE GOLD AND SILVER JEWELRY,

MOUNTERS OF DRESDEN CHINA AND CUT GLASS.



ALSO  
BLOTTERS,  
PAPER KNIVES,  
PEN TRAYS,  
PEN WIPER STANDS,  
LETTER FILES  
AND  
CANDLESTICKS.



IN THE DIFFERENT  
DECORATIONS  
TO MATCH THE INK-  
STANDS, MAKING  
THE  
COMPLETE DESK  
SET,



DRESDEN INKSTANDS.  
MOUNTED IN STERLING  
SILVER.

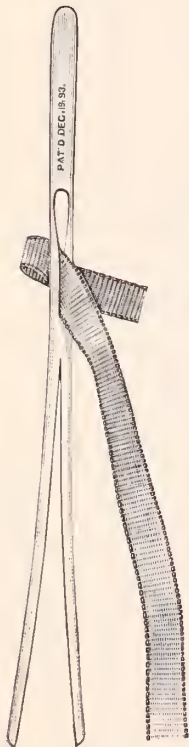

A TAPE NEEDLE THAT WILL PRE-  
VENT THE TAPE FROM  
TWISTING.



<p>ENGLISH DICTIONARY PRINTED ON OXFORD INDIA PAPER</p>	<p>ENGLISH DICTIONARY</p>	
<p>EXACT SIZE. 884 Pages. Weights 44 Grains.</p>	<p>Case with Magnifying Glass.</p>	<p>SPECIMEN OF PAGE.</p>
<p>THE SMALLEST ENGLISH DICTIONARY IN THE WORLD.</p>		



## HISTORY OF THE AMERICAN WATCH REPAIRERS' LATHE.

**P**REVIOUS to 1860 the only lathes known to the watch repairers were the Bottom Lathe, the Jacot, and the Swiss or English universal lathes. The improved tools and the improved method of handling watch work, as developed in the American Watch Co.'s works at Waltham, convinced the watch repairers there, that the spring chuck with draw-in spindle, as used in the factory, would prove a great convenience to the watch repairer. With this in mind, Chas. S. Moseley designed in 1859 a lathe with round bed and round pedestal bolted together, and with head and tail-stock as used in the factory; also using the wire spring chuck; and he considered the matter of going into the business of manufacturing such lathes, but his engagements with the Nassau Watch Co. prevented his putting this plan into execution. Therefore the plan lay dormant until the Summer of 1861 when in consequence of the depressed state of the watch business, Royal E. Robbins gave A. Webster, foreman of the machine shop of the American Watch Co., directions to discharge a number of workmen.

Mr. Webster advised the watch company to retain the machinists and take up the business of manufacturing a watch repairers' lathe. After some persuasion Mr. Robbins consented to the scheme, and Mr. Webster then designed and commenced the manufacture of what proved to be the first "American combination watch repairers' lathe," consisting of the bed and pedestal of Moseley, with a head-stock, tail-stock, universal head and slide rest. Thirty of each

of two sizes of this lathe were begun, but before they were completed, the watch business revived and in consequence all but two of the lathes went into the watch factory for manufacturing purposes. One was completed and used for many years by A. T. Bacon, the superintendent, as a model making lathe. This first lathe, as well as the drawings, are now in the possession of Ambrose Webster, of the American Watch Tool Co., of Waltham.

After the revival of the business, two of the machinists employed in the manufacture of these lathes, Messrs. Kidder and Adams, left the factory and started the business in a town adjoining Waltham, but were not successful in their undertaking. The business was afterward removed to Waltham, and John Stark obtaining possession of it, continued for many years the manufacture of this lathe.

Machinists connected with other watch factories made feeble attempts to start the manufacture of lathes in competition with Mr. Stark, and in 1872 Messrs. Ballou and Whitcomb, who were machinists employed by the American Watch Co., started the business of making lathes on the lines of those being made in the factories, but very much improved in the details of construction. They started in Boston, but afterwards removed to Waltham and took the name of American Watch Tool Co. The reputation of the Ballou, afterwards known as the Whitcomb lathe, was at once assured, for in its construction hardened steel spindle and hardened steel bearings had

been adopted, as were in use at that time in the American Watch Co.'s works. This particular construction of spindle and bearings was an invention of Mr. Webster, and the first lathe in which they were introduced was built by George Hunter, present superintendent of the Elgin National Watch Co., who was then working as a machinist in the American Watch Co.'s works.

A year or two later Chas. S. Moseley again took up the project of building lathes for watch repairers, and started in business in Elgin, where it is now carried on by his brother, Horace Moseley. Since these two leading manufacturers started in business there have been several unsuccessful as well as successful attempts to manufacture lathes, the principal being the Waltham Watch Tool Co., the Mansfield Watch Tool Co., Ohio Watch Tool Co., Faneuil Watch Tool Co., and the Horological Tool Co., the last of Chicago.

The high reputation of the Moseley and the Whitcomb and Webster-Whitcomb lathes has been such that they have been taken to Germany and Switzerland, and copied with a great degree of accuracy, so far as externals are concerned; but the details of construction and accuracy in details to secure interchangeability are yet beyond the conception of the Swiss and German manufacturers, who have not passed through the years of experience which our American machinists have served in the line of work of precision, to enable them to compete in quality with the American manufacturers.

## THE LARGEST DIAMOND OF THE DECADE.

**K**IMBERLEY, Dec. 16, 1893.—I learn from London that the Emperor of Germany is eager to purchase the big diamond found at the Jagersfontein mine, July last. This monster gem turns the scale at 971 karats, and there seems good reason for believing that it is the very biggest in the world. Some of the Oriental potentates have very large diamonds, the weight and size of which they are not anxious to disclose to Europeans, and it is thought that there are several in existence approaching nearly the size of the Jagersfontein gem. The latter is of fairly good color and shape, and has been christened the Jagersfontein "Excelsior." As I mentioned when recording the find, this diamond has a somewhat interesting history.

The Jagersfontein mine, which is situated about 50 miles from Kimberley, and within the territory of the Orange Free State Republic, is owned by a company, many of the shareholders of which reside in England, and few of them on the spot. For some

time they have sold the yield of diamonds by public tender in advance. The contractors for the purchase of the diamonds in July were Messrs. Wernheim and Beit, and their contract expired on the very day this famous stone was found. Had it been handed to the manager only a few hours later it would have fallen into other hands.

The "Excelsior" was found by a native Basuto laborer named Jonas, and he could easily have secreted it, as has been done in thousands of cases no doubt, because it happened that he was working alone at the time at a place where no diamonds were expected to be found. However, he promptly placed it in the hands of the manager, who did not for a considerable time realize its enormous value. The natives at the mine, as an encouragement to zeal and honesty, are allowed a small commission upon the diamonds they find and Jonas' share was about £30. This sum to an African native is quite a small fortune and as the bonus was supplemented by the gift of a horse, saddle and

bridle, the Basuto left for his home a very proud man.

On the spot the diamond was valued by the Official Government Inspector at £25,000, but when it reached Kimberley a bid of £250,000 was made for it. The offer was declined and the "Excelsior" was shipped to Europe. It was a curious sight to see the parcel guarded to the Capetown docks by a squad of cavalry and a detachment of police. It reached England safely and immediately the value went up until now the owners decline to part with it for less than £1,000,000. It has been lodged in the Bank of England for security, and at the present time negotiations are proceeding for its purchase on behalf of the German Emperor who is having a new crown constructed and has an idea, apparently, that this particular gem will add lustre to the diadem. He is not, however, the only bidder in the market, and it is quite uncertain yet what will be the gem's ultimate destination.

FREDERIC ST. GEORGE.

ESTABLISHED 1870.



**S. C. JACKSON,**

MANUFACTURER OF

**FINE CASES**

• • • FOR • • •

**Jewelry, Silverware, &c.**

ALSO

**SHOW CASE TRAYS, HARD WOOD CHESTS**

AND

**SAMPLE BOXES OF EVERY DESCRIPTION.**

**180 BROADWAY,**

**NEW YORK.**



# DEITSCH BROS.,

7 EAST 17TH ST., NEW YORK.

## LEATHER GOODS.

EBONY AND SILVER COMBINATIONS.

ORIGINATORS AND MAKERS OF  
NOVELTIES IN  
LEATHER AND  
STERLING SILVER  
COMBINATIONS.



### The "Bryant" Rings.

Are widely advertised and will sell when anything will, therefore every Retail Jeweler should buy them.

IF NOT CALLED UPON BY OUR TRAVELERS  
ORDER DIRECT FROM

**M. B. BRYANT & CO.,** 10 MAIDEN LANE, N. Y.  
OLDEST RING MAKERS IN AMERICA.



Sold by all wholesale dealers at manufacturer's price.

**A. N. CLARK,**  
PLAINVILLE,  
CONN.

Manufacturer of the Celebrated  
**LOOP WATCH KEY.**

The Best for the Price in the World.  
CROSBY'S JEWELING TOOLS IMPROVED.

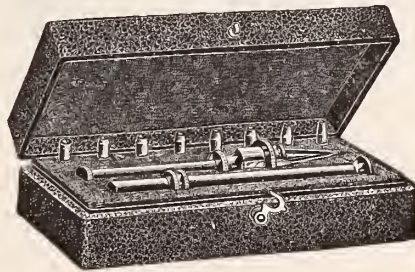
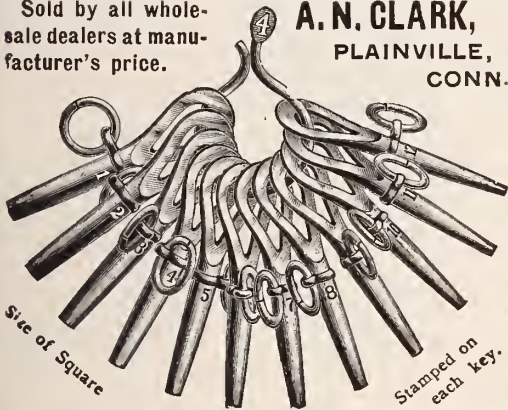

Will quote royalty or price for the manufacturing of articles of real worth.

**If Your Sales  
Are Not Satisfactory**

ADDRESS

**DE B. O. SCOTT,**  
20 Murray Street, New York.  
AUCTIONEER.

Specialties: Watches, Clocks, Bric-a-Brac, &c.

Write for particulars and references.

DON'T FORGET the JEWELER'S CIRCULAR PUBLISHING CO.'S BOOK LIST when in want of any technical book in the Jewelry or Kindred Trades.



**THE QUESTION ?**  
WILL IT TARNISH ? Need  
not be asked if your Tissue Paper bears  
this label.

MANUFACTURED BY

**C. H. Dexter & Sons,**  
WINDSOR LOCKS, CONN.

**BE SURE YOU GET THIS BRAND.**

It has been adopted and is now used by the leading manufacturers of this country.



**AWARD** At World's Columbian Exposition, Chicago.

# LEON FAVRE,

107 E. 26th Street, New York.

Ivory and  
Enamel  
Miniatures.

Best  
Workmanship.



Original  
Inventor and  
Patentee of  
**Miniatures**  
—O—  
**Gold and  
Silver.**

PATENTED  
November 12, 1889.

**INFRINGERS PROSECUTED.      LOWEST RATES.**  
**SEND A TRIAL ORDER.**

HAVING SEVERED MY CONNECTION with the Roy Watch Case Co., my former agent, I am now enabled to reduce the price of MINIATURES from \$6.00 to \$3.00, thus giving the Trade an opportunity of offering MY GENUINE and DURABLE process at THE PRICE OF CHEAP and counterfeit work.

## MATHEY BROS., MATHEZ & CO.,

21 & 23 MAIDEN LANE, N. Y.  
BRASSUS, SWITZERLAND.

Manufacturers and Importers of  
**Plain and Non-Magnetic  
Movements.**

COMPLICATED WATCHES A SPECIALTY.  
A Full Line of 10 and 16 Size

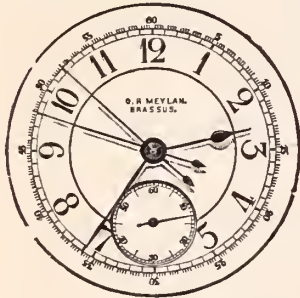

# SPLITS.

ESTABLISHED 1837.  
**GEO. O. STREET & SONS.**  
MAKERS OF  
Fine Rings, Lockets, Seals,  
Sleeve Buttons and Links  
15 John Street, NEW YORK.

## LEGENDS OF GEMS.

BY FRANK SHELLEY.

Gilt edged; bound in leather; a perfect specimen of the printer's and binder's art. Should be in every jeweler's library. Price, \$1.00. For sale by

THE JEWELER'S CIRCULAR PUB CO.

## VICTOR. ⊗ ⊗

SIMPLEST FEED. ALWAYS THE SAME.  
GUARANTEED FOR ONE YEAR.

## THE VICTOR FOUNTAIN PEN

(Pat. Feb. 4, 1890.)

THE BOSTON PEN CO.,

N. C. Whitaker & Co., Proprietors.

363 Washington Street, Boston, Mass..

Manufacturers of finest quality

TORTOISE : SHELL : AND : HORN : GOODS  
in every variety. Also Aluminum Hair Pins.

Send for Illustrated Pen Price List No. 1.



## M. L. READ & CO.,

161 DORRANCE ST.,  
PROVIDENCE, R. I.

THE  
Old

Reliable  
House

FOR  
STICK PINS AND  
WHITE STONE GOODS.

# OPPENHEIMER BROS. & VEITH, WATCHES AND

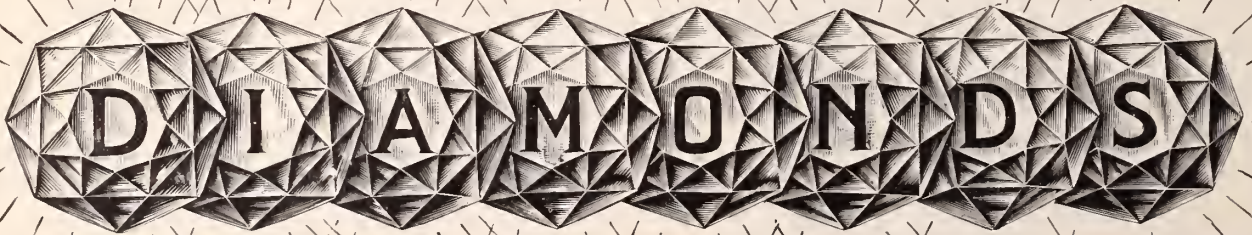

A Large Line of DUEBER Solid Gold Cases. Filled Cases. Silver Cases.  
Our Specialty: HAMPDEN MOVEMENTS, 6, 16 and 18 Sizes.

AMSTERDAM, HOLLAND, 2 TULPSTRAAT.      LONDON, ENG., 28 HOLBORN VIADUCT.      NEW YORK, 35 MAIDEN LANE.



### A Bill to Make All Debts Mature at Insolvency.

ALBANY, N. Y., Feb. 2.—A bill which has been introduced in the Legislature by Senator Jacob A. Cantor has for its object, in brief, the maturing of all debts and obligations of an insolvent debtor at the time of his insolvency. There appears to be little reason to doubt that the bill was drafted at the instance of the business men of New York and other large cities, and is intended to protect them. Those who would receive the greatest benefits if the bill becomes a law would be the wholesale jewelry and other firms who give long credits, and date bills ahead. These firms have given the bill their emphatic approval and support, as they see in it a remedy for an evil which they have long been contending with and which has seemed to be getting more general.

In the jewelry trade it is customary for wholesale firms to sell to the trade on liberal terms. As a consequence the wholesaler takes risks which have proved very unprofitable to the wholesale jewelers during the past few years. A retailer who was not honest would obtain long credit from several big jewelry firms. Then at a convenient time he would make an assignment to someone with whom he was in league. The wholesalers' bills would not be due perhaps for months, and their hands were tied. They could do nothing to protect themselves. It was impossible for them to institute suits, as their accounts were not due. Prior claims had sway, and the wholesalers invariably got the worst of it.

Dan'l P. Hays, of Hays & Greenbaum, said to a CIRCULAR reporter: "I am heartily in favor of the proposed bill introduced by Senator Cantor, to make due immediately all debts owing by a person who commits an act of insolvency. One of the greatest evils which creditors have to contend with under the present law is that when a debtor fails he so arranges it as to protect those who occupy a confidential relation towards him, and the merchandise creditors are hampered and delayed in any proceeding they may chance to take against him by reason of the fact that the credit upon which they sold their goods has not expired. This is a great injustice to the merchants and the honest creditors and benefits no one but the debtor, and the only manner in which it benefits him is to give him time within which to carry out any scheme or plan he may have conceived for the purpose of defrauding his honest creditors."

### Fritzie Dhein at Length Run to Earth.

Through the efforts of the Jewelers' Protective Union, a noted diamond thief, Fritzie Dhein has been run to earth. A telegram received Saturday stated that Dhein had been captured by Pinkerton detectives at Hot Springs, Ark. The Pinkertons do the work for the Jewelers' Protective Union, and they have been hunting for Dhein since Nov., 1891, when he stole \$15,000

worth of diamonds. The robbery took place at the railroad station in Dayton, O., where, on Nov. 10, 1891, Dhein entered a car of a train and stole a satchel containing the gems from R. E. Kramig, a salesman for the Herman Keck Mfg. Co., Cincinnati.

Pinkerton's men were notified, and on Dec. 13, through the arrest of William Hurless, alias Charles Blondy, an alleged accomplice of Dhein, the diamonds were recovered. The entire lot was found in four glass fruit jars, buried on a farm at Jeffersonville, O. A few days later the detectives captured Dhein. At the trial at Dayton, O., the jury disagreed and while out on bail pending a new trial, Dhein skipped.

The detectives got on his track and kept it over a goodly portion of this country and then to Europe, but Dhein always was a few days ahead of his pursuers. Following him back from Europe to New York they lost him, but a few days ago got the trail again and located him at the race track at Hot Springs, where he was captured. He will be taken to Dayton, O., for trial.

### Proceedings in the Settlement of Edward Moulton.

WORCESTER, Mass., Feb. 1.—Before Judge William T. Fowler, in the Court of Insolvency, Friday last, there was an adjourned hearing on the new offer of composition of 30 cents in the case of Edward Moulton, jeweler, 389 Main St., who failed last November. He at first offered 25 cents, and the court appointed as one of the assignees Albert Walker, of Providence. On account of the holiday trade no definite action was taken on the original offer of compromise of 25 cents on the dollar, and at the meeting last week the new offer of 30 cents was made.

At this meeting claims were approved, and the hearing was further adjourned until Tuesday, Feb. 6th, when it is expected the offer will be confirmed. It is claimed that the necessary number of creditors have assented to the new offer.

### C. D. Place Has Very Little Assets.

BOSTON, Mass., Feb. 2.—C. D. Place, optician and jeweler, who occupied part of the store of George H. Whitford, 421 Washington St., has removed to 6 Winter St. He is financially embarrassed and his business affairs will be settled by insolvency proceedings. Mr. Place's liabilities are in the neighborhood of \$15,000 and his assets are practically *nil*, as most of the stock that he had on hand has been taken by virtue of a mortgage held thereon by one of his creditors.

Mr. Whitford will take the entire store for the present and add the optical branch to his present business. Samuel Leonard, formerly with C. D. Place, enters Mr. Whitford's employ in this department.

B. Marker, Dushore, Pa., expects to locate in Montrose, Pa., about April 1.

ESTABLISHED 1866.

*Lissauer & Company*

Manufacturers, Importers and Jobbers of!

**WATCHES,**  
**DIAMONDS**  
**AND JEWELRY,**  
 12 MAIDEN LANE,  
 NEW YORK.



March 28, 1893.

P. O. Box 2516.

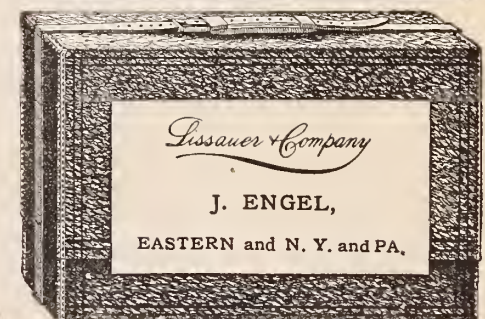
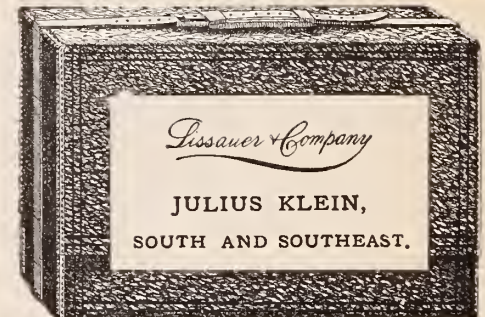
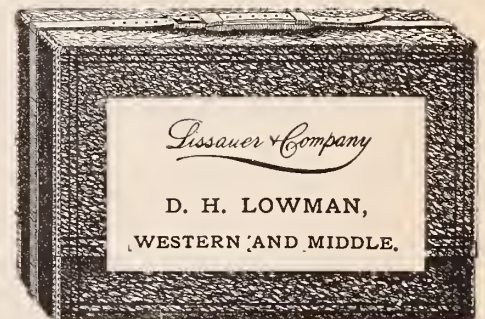

Our representatives, as named above, are now on the road with a complete stock, and will call on the legitimate jewelry trade only. Kindly reserve for them a share of your patronage.



# EMPIRE GOLD and SILVER PLATING WORKS.

## FRITZ MORRIS, GOLD • AND • SILVER • PLATING

IN ALL THEIR BRANCHES.

Case Repairing, Polishing, Etc., Dial Painting, Coloring, Gilding, Etc.

75 and 77 NASSAU STREET, NEW YORK.

It is economy to save a penny when you can. You will save many pennies by sending anything in the plating line to my factory, where it can be renovated, replated, recolored or repaired satisfactorily, and at a price beyond competition. I make a specialty of jewelry, romanizing and satin finishing, and of family table ware. Others speak of their good work, my work speaks for itself. Out of town trade solicited and estimates cheerfully given.

FRITZ MORRIS.



Send for Illustrated Catalogue.

## A Revolution in the Music Box Trade.

It is an American music box, immeasurably superior in tone, execution and simplicity of construction to ordinary music boxes costing four times as much. By means of interchangeable metallic plates, obtainable at a trifling cost, it will play an unlimited number of tunes of every variety, including the latest operatic and popular airs.

A. WOLF,  
194 Broadway, New York.

## MARINE CHRONOMETERS,

MANUFACTURED BY

John Bliss & Co., 129 Front St., New York.



We have on hand a number of Chronometers, by various good makers, but new which have been in service for purposes of navigation, and are excellent instruments. They have been put in perfect repair and will give satisfactory results as to performance. We will sell these Chronometers at low prices, either for cash, or on accommodating terms to suit special cases, or will hire them at moderate rates and allow the hire to apply on purchase.

SEND FOR CIRCULAR GIVING PRICES AND TERMS

## Jobbers Give Testimony in the Dueber Suits.

The commission recently issued to take testimony of witnesses in Pittsburgh, Pa., in the litigation between the Dueber Watch Case Mfg. Co. and the Co-operating Manufacturers has been returned to the New York Supreme Court. The following named jobbers were examined: Geo. B. Barrett, of Geo. B. Barrett & Co.; Otto Heeren, of Heeren Bros. & Co.; Geo. E. Goddard, of Goddard, Hill & Co.; Morris Kingsbacher, of Kingsbacher Bros., and Isidore Ollendorf. Their testimony covers 170 pages of legal cap, and gives in detail the history of the National Association of Jobbers in American Watches and its connection with the association of the manufacturers. All the parties examined except the last two are still members of the National Association.

The principal testimony given is in regard to when and why they ceased to buy Dueber goods. In this connection, Otto Heeren says: "As far as we were personally concerned we would like to have had the sale of the Dueber Co.'s goods continued, as we have always been great friends of the concern. While we had a chance to throw as much trade as possible in their favor, we have, of course, transferred their trade to other parties."

Wilber & Oldham, the counsel for the Dueber Co., state that commissions will at once be issued to examine the prominent jobbers in Chicago, St. Louis, Cincinnati, Cleveland, Milwaukee, Boston, Philadelphia and all the other prominent cities of the United States.

## A Clever New Game Worked on Jeweler W. F. Morse.

BOSTON, Mass., Feb. 3.—Wednesday evening, William F. Morse, jeweler, 268 Tremont St., who has been robbed more times by crooks than any other dealer in the trade in this city, was again victimized by a couple of nimble thieves.

It was a little after 6 o'clock when the pair entered the store. They asked to be shown some diamond rings. One of the men said there was a ring in the show window which suited him better than anything in the tray which Mr. Morse had placed before them. He went outside to point out the ring from the sidewalk, leaving the door open as he stepped out. When Mr. Morse reached into the window space to get the ring, however, the fellow's accomplice snatched three rings from the tray, valued at \$220, and both were out of sight before the proprietor could give chase.

## Death of Edward Fisher.

POTTSVILLE, Pa., Feb. 4.—Edward Fisher, the well-known jeweler, after a year's treatment at the Pennsylvania Hospital, in Philadelphia, died in that institution last week. A wife, two daughters and two sons survive. He served as a soldier during the early stages of the rebellion, and was a member of Gowen Post, No. 12.



**Diamond Importers Petition the Senate.**

A. J. G. Hodenpyl, chairman of the committee of diamond importers, has sent a letter to Senator Voorhees, of which the following is a copy:

*To The Honorable Daniel Voorhees, Chairman of the Committee on Finance.*

UNITED STATES SENATE, WASHINGTON, D. C.

SIR:—Your petitioners respectfully ask that the duty on cut, but unmounted diamonds and other precious stones, and on unmounted pearls, shall not be changed from the present tariff of 10 per cent. ad valorem, which has been the rate since 1864, having been raised to meet the necessity for increase of revenue, from 4 per cent. in 1860 to 5 per cent. in 1861. The present tariff has rendered to the Government a constantly increasing revenue, as it has enabled the importer and dealer to increase their dealings.

The rate of duty now proposed, i.e., 30 per cent. on cut diamonds and other precious stones, and 15 per cent. on rough or uncut material, is certain to result in loss of revenue to the Government and great injury to importers and dealers for the following reasons:

The excessive high rate is a tempting invitation to the unscrupulous all over the world to smuggle, as, owing to the facility with which they can be concealed, the risk of detection is small, and the profit of each successful venture so enormous that a seizure or detection from time to time would still leave a large margin of profit. Many reputable importers will be forced into other channels of business, and the amount of importation will certainly be greatly reduced.

Our wealthiest people who visit Europe almost every Summer, will make their purchases abroad, bringing them home as personal effects and not dutiable, which will be just so much loss to the American dealers, as well as a loss of revenue to the Government.

In addition to the loss of revenue through smuggling and decreased importation, the Government will incur increased expenses in its endeavors to prevent frauds and smuggling, which, at the high rate of duty, is sure to follow.

As a matter of protection to the diamond cutters the high tariff of 10 per cent. and rough free, is in our opinion the best which can be proposed in their, the cutters', interest, for the reason that the smuggling of cut goods which, a higher duty than 10 per cent. would bring about, would compel them to sell at a profit so small as to be disastrous. Moreover, as there are less than 200 workmen engaged in diamond cutting in this country, it is obviously quite unnecessary and unwise to place so high a tax as is proposed for the benefit of an industry which cannot possibly for years be developed sufficiently to meet even a small portion of the demands of the diamond trade.

Should the bill become a law, not only will great injury be done to dealers in diamonds, but thousands of working jewelers now engaged in setting diamonds in various objects of jewelry will find themselves without employment.

Messrs. Tiffany & Co., Hodenpyl & Sons, Randel, Baremore & Billings, Alfred H. Smith & Co., H. C. Hardy & Co., L. & M. Kahn & Co., Bruhl Bros & Co., have been appointed our committee to wait upon you in our interests when desired.

A. J. G. HODENPYL, *Chairman,*  
170 Broadway, New York.

**Samuel Horowitz Charged With Receiving Stolen Goods.**

PITTSBURGH, Pa., Feb. 5.—Samuel Horowitz, jeweler, at 41 Federal St., Allegheny, was held in \$1,000 bail for court by Magistrate McKelvey, of that city, last week to answer a charge of receiving stolen goods. It is charged that a quantity of the goods stolen by Annie Alexander, a notorious sneak thief, who is detained at the Allegheny Central station, was found in Horowitz's store, where they had been sold by the woman.

**Rosenstihl Bros. Closed Under an Attachment.**

BIRMINGHAM, Ala., Feb. 5.—Rosenstihl Bros. have been closed under an attachment for \$5,000 in favor of J. R. Smith, Jr., their landlord, in default of payment of rent on a three years' lease contract.

The assets and liabilities are about \$12,000 each. The firm recently offered to settle with their creditors at 33 1/3 cents, one-half cash and balance payable in two equal instalments in two and four months without interest.

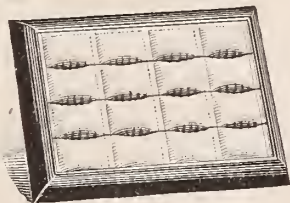
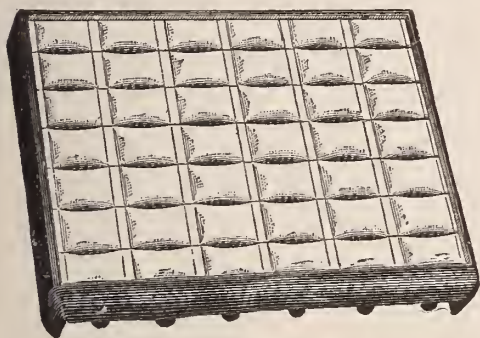

**CELLULOID NOVELTIES**

FOR RINGS.

Patented June 6, 1893.

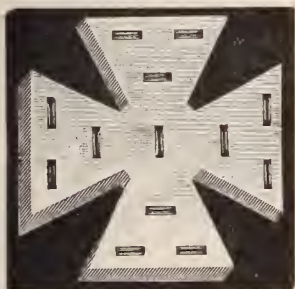

FINE, HANDSOME, ORNAMENTAL.  
Top, Bottom, Sides and Cushions  
all Made of Celluloid.

CROSS, HEART, STAR,  
LEAF, CRESCENT, 1-4 CIRCLE,  
FLEUR DE LIS, ETC.

ANY DESIGN MADE TO ORDER.

DIAMONDS SHOW MORE FIRE,

RUBIES SEEM TO HAVE A BETTER COLOR,

SAPPHIRES LOOK RICHER,

ALL OTHER GEMS ARE TWICE AS PRETTY

WHEN SHOWN ON PURE WHITE VELVET FINISH CELLULOID LINING.

Patented December 27, 1892.

Which considering its durability, is the most inexpensive lining in the market. Thousands of Jewelers have found this out before you. Write for Samples and Price List to your jobber, or to

**A. TROESCHER & CO.,**

Inventors and Manufacturers,

69 NASSAU STREET,

NEW YORK.



ALSO MANUFACTURERS OF

Fine Velvet, Kid, Morocco and Plush Cases,

FOR

Jewelry, Silverware, Etc., of every description.

TRAYS FOR SHOW CASES,

Jewelers' Sample Cases, Etc.

Travelers' Ring Trays with Patent Celluloid Lining a Specialty.



**The Good Work of the Jewelers' Relief Association.**

President Lissauer, of the Jewelers' Relief Association, has called a meeting of that organization for this afternoon at 2 o'clock P. M. A report of the work done by the various committees will be submitted, and other important business transacted. The relief and employment committee have met daily during the past week.

Over sixty of the hundred and thirty applicants have been assisted. Nearly every case represented a family of four or five persons, making the total number actually assisted, between 250 and 300. Food and clothing have been supplied, but the relief most necessary is employment. Cases have been found where, though the families were starving, they absolutely refused charity of any sort. Some of these cases were relieved by a loan, but this was the only assistance they would accept.

The subscriptions received within the past week are as follows:

Previously acknowledged .....	\$3,153.00
Error in J. Bulova, should be \$25 instead of \$5.....	20.00
Whiting Mfg. Co.....	200.00
Gorham Mfg. Co.....	100.00
Holmes Electric Protective Co.....	100.00
L. & M. Kahn & Co.....	75.00
J. B. Bowden & Co.....	50.00
New York Standard Watch Co.....	50.00
H. F. Barrows & Co.....	50.00
Spencer Optical Mfg. Co.....	50.00
Henry E. Oppenheimer & Co.....	50.00

Employees of Stern Bros. & Co.....	50.00
Howard & Co.....	50.00
Ludwig, Redlich & Co.....	50.00
Reed & Barton.....	50.00
Adolphe Schwob.....	50.00
Cross & Beguelin.....	25.00
S. F. Myers & Co.....	25.00
Goodman Bros.....	25.00
Fidelity Watch Case Co.....	25.00
Falkenau, Oppenheimer & Co.....	25.00
Peckham Seamless Ring Mfg. Co.....	25.00
Odenheimer, Zimmern & Co.....	25.00
Sussfeld, Lorsch & Co.....	25.00
H. Dreyfus & Co.....	25.00
Sol. Lindenborn.....	25.00
Kremetz & Co.....	25.00
A. J. Hedges & Co.....	25.00
Wood & Hughes.....	20.00
Smith & Knapp.....	20.00
Hipp Didisheim & Bro.....	20.00
H. Z. & H. Oppenheimer.....	15.00
J. M. Berinstein.....	15.00
Wollstein & Sulzberger.....	10.00
L. Sauter & Co.....	10.00
Ira Goddard.....	10.00
John R. Greason.....	10.00
A. Wittnauer.....	10.00
J. F. Saunders.....	10.00
E. Karelsen & Co.....	10.00
Durlach Bros.....	10.00
Sig. Hirschberg.....	10.00
Manasseh Levy.....	10.00
Waterman & Lehmann.....	10.00
C. E. Mather.....	10.00
Ernest Adler.....	10.00
L. J. Glaenger & Co.....	10.00
Paul Jeanne.....	5.00
C. F. Voelker.....	5.00
Henry Abbott.....	5.00
E. F. Sanford & Co.....	5.00
Otto E. Metzger.....	5.00
F. A. Lewis.....	5.00
J. E. Palmer.....	5.00

J. Drukke.....	1.00
J. E. Masters.....	1.00
Total.....	\$4,715.00

**An Interesting Suit Ament the Manufacture of Watch Cases.**

A suit has been on final hearing before Judge Coxe in the United States Circuit Court, New York, Friday and Monday, which involves the invention of the method of ornamenting watch case centers in intricate patterns as vermicelli by knurling.

The invention was the subject of a long litigation in the Patent Office in which the Examiner of Interferences decided for Frederic Ecaubert, who now brings suit, against Robbins & Appleton who claimed the invention as assignees of one of their workmen, A. W. Hofmann. On appeal to the Board of Examiners in Chief, the decision of the examiner was affirmed. Robbins & Appleton took an appeal to the Commissioner of Patents and the Board was reversed and a patent was granted to them. Before that, however, a patent had been granted to Ecaubert on another application not in interference and on that patent the suit argued was brought. This was also included in the argument, and a suit and cross-suit between the same parties in the Eastern District of New York, were brought in which it is sought to cancel the one or other of these patents.

Mr. Ecaubert is a machinist and maker of tools for watch case manufacturers.

# FLETCHER PATENT SYSTEM OF TRAYS.

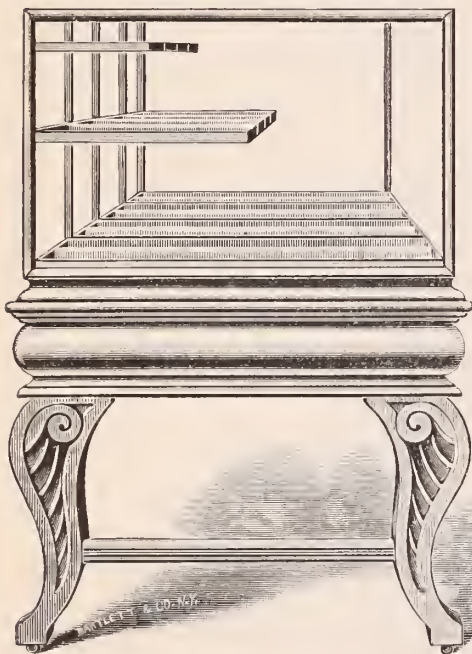

The trays are supported in an absolutely invisible manner. There is no obstruction whatever. The entire floor, also the space between the trays, is clear room to work in—viewed from the front, end or at the back nothing can be seen nor touched but the trays. When a Tray is removed there will be nothing but clear space left. The effect is precisely the same with from one to seven rows of Trays. Will operate practically in wall cases.

Send for Illustrated Catalogue.

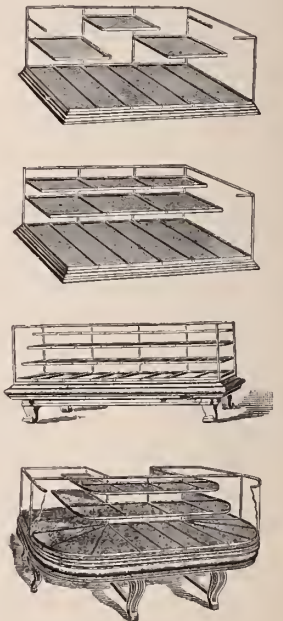

FLETCHER M'F'G CO.  
259 W-27<sup>th</sup> St NEW YORK.

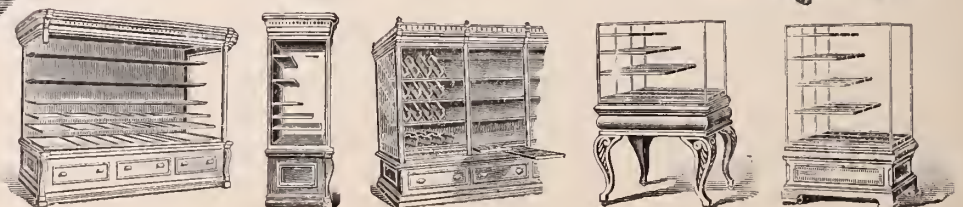



# The Jewelers' Circular

AND  
HOROLOGICAL REVIEW.

PUBLISHED EVERY WEDNESDAY BY

**THE JEWELERS' CIRCULAR PUB'G CO.,**  
189 BROADWAY, NEW YORK CITY.

A JOURNAL DEVOTED TO THE INTERESTS OF JEWELERS, WATCHMAKERS, SILVERSMITHS, ELECTRO-PLATE MANUFACTURERS, AND ALL ENGAGED IN KINDRED BRANCHES OF INDUSTRY.

Our Editorial columns will contain our own opinions only, and we shall present in other columns only what we consider of interest or value to our readers. Advertising matter will not be printed as news.

Advertising rates in THE CIRCULAR are lower, considering the number of tradesmen reached by its large circulation, than in any other jewelry journal.

Notices of changes in standing advertisements must be received one week in advance; new matter can be received up to Monday.

## INFORMATION FOR SUBSCRIBERS.

### Terms of Subscription, Postage Prepaid.

PER ANNUM  
United States and Canada, - - - \$2.00  
Foreign Countries in Postal Union, - - - 4.00  
Single Copies, - - - - - .10

New subscribers can commence at any time.

Payments for THE CIRCULAR, when sent by mail, should be made in a Post-Office Money Order, Bank Check or Draft, or an Express Money Order or Registered Letter. All postmasters are required to register letters whenever requested to do so.

Pay money only to authorized collectors having proper credentials.

Returning your paper will not enable us to discontinue it, as we cannot find your name on our books unless your address is given.

In changing address always give the old as well as new one. Your name cannot be found on our books unless this is done.

We will continue to send papers until there is a specific order to stop, in connection with which all arrearages must be paid; but such an order can be given at any time, to take effect at the expiration of the subscription. All such orders will be promptly acknowledged by mail.

The Courts have decided that all subscribers to journals are responsible until arrearages are paid in full and an order to discontinue has been received by the publisher.

Member of the American Trade Press Association.

VOL. XXVIII. Feb. 7, 1894. No. 1.

THE generosity of the jewelry trade is proverbial. The charitable instincts of the jewelers of New York and Chicago are in evidence in a most desirable and tangible form, as seen in the lists of contributions published in THE CIRCULAR of this and previous weeks. However, while pecuniary subscriptions are imperatively demanded, still every firm and individual having or knowing of any possible position for work open, should communicate with the relief committees, as even among the most destitute there are some who refuse money, the cry being for work, let it be never so menial.

THE event of the week in Congress was the passage of the Wilson bill by the House of Representatives. The House on Wednesday decided by a vote of 175 to 55 to add the internal revenue bill with the income tax feature to the Wilson bill, and the completed measure was brought to a vote on Thursday evening, when the bill was passed by a vote of 204 to 140. The

## TABLE OF SPECIAL CONTENTS.

EXPRESSLY WRITTEN AND ILLUSTRATED FOR THE CIRCULAR.

	PAGE
I. THE SILVER ANNIVERSARY OF THE JEWELERS' CIRCULAR. . . . .	1
Illustrated.	
II. THE CLOCK THAT SOT ERGIN THE WALL. A Poem. . . . .	8
By George W. Stevens.	
III. CHARLES L. TIFFANY AND THE HOUSE OF TIFFANY & Co. . . . .	16
By George Frederick Heydt.	
IV. THE COMMERCIAL TRAVELER. . . . .	21
By John L. Shepherd.	
V. THE AMERICAN WATCH AS A PRODUCT OF 19TH CENTURY GENIUS. . . . .	24
By Excelsior.	
Illustrated.	
VI. A QUARTER CENTURY IN THE PRECIOUS STONE INDUSTRY. . . . .	35
By George F. Kunz.	
VII. THE JEWELRY FASHIONS OF THE FUTURE. . . . .	39
By Mary Gay Humphreys.	
VIII. THE ART AND DEVELOPMENT OF AMERICAN SILVERSMITHING. . . . .	41
Introduction, by J. H. Buck; Special Pieces in Silver, by B. F. S.	
IX. THE DIAMOND CUTTING INDUSTRY IN AMERICA. . . . .	53
Illustrated.	
X. STORIES BY THE CIRCULAR'S CORRESPONDENTS. . . . .	58
Illustrated.	
XI. THE KINDRED LINES OF THE JEWELRY TRADE. . . . .	72
By Edw. J. Deitsch, George S. Lemcke, Wm. F. Dorflinger, Ignatius Rice, F. Kroeber and E. Davidson.	
XII. ARTISTIC CLOCKS IN NEW YORK'S PALATIAL HOTELS. . . . .	75
By Richard H. Keller.	
Illustrated.	
XIII. THROUGH THE VISTA OF PAST FASHIONS. . . . .	78
By Elsie Bee.	
XIV. THE JEWELRY INDUSTRY OF PROVIDENCE. . . . .	81
By William H. Mason.	
Illustrated.	
XV. HISTORY OF THE AMERICAN WATCH REPAIRERS' LATHE. . . . .	85
XVI. THE LARGEST DIAMOND OF THE DECADE. . . . .	85
By Frederic St. George.	
XVII. THE HISTORY AND ART OF ROYAL BERLIN PORCELAIN. . . . .	107
Illustrated.	
XVIII. THE MYSTERY OF THE PEARL NECKLACE. A Story. . . . .	114
By Abi S. Jackman.	
Illustrated.	

amendments to the bill made in Committee of the Whole were adopted by the House. If the debate on the measure in the Senate lasts less than six months, many persons will be surprised.

### A Tariff for HON. WM. BURKE COCKRAN, in the Revenue Only. House, laid down the correct principle of tariff

taxation for revenue, when taken to task by Hon. Amos J. Cummings, for favoring a 10 per cent. duty on precious stones, cut and unset. Mr. Cummings took umbrage because Mr. Cockran had corresponded with A. J. G. Hodenpyl on the subject, and had the letters published in THE CIRCULAR read from the clerk's desk. Mr. Cockran said among other things:

"I do not take the floor for the purpose of making any explanation of the correspondence which has been read by the gentleman from New York. There are probably extant a thousand letters of that character signed by me; and the fact that this particular letter was read from the desk, or read in the course of the gentleman's remarks, would not justify me in trespassing upon the time of the committee by any discussion of it. \* \* \*

"We have had the assurances of the treasury officers that a duty of 10 per cent. upon diamonds is the duty which would yield the best results from a revenue

standpoint. We accepted that judgment. We decided in the Ways and Means Committee to restore the duty at 10 per cent. after it had been raised to 15 per cent. When the duty was originally placed at 15 per cent., that rate was fixed, I believe, under the impression that 15 per cent would yield a larger revenue—"

Mr. Livingston—If we can collect 10 per cent. why could we not collect 15 per cent.?

Mr. Cockran—The gentleman asks me a reason for the advice given by the treasury department. He wants to know why we could not collect 15 per cent. if we can collect 10 per cent. I answer him I do not know. But every person who has been concerned in revenue collection knows that upon every article there is a certain duty which yields the largest amount of revenue, and that when you go above or below that point the receipts are diminished. We took the judgment of treasury experts on this subject deeming it a better guide than the judgment of the gentleman from Georgia

It is a delusion that higher tariff duties produce greater revenues. Precious stones are a merchandise that yield less revenue as the duty on them is increased. It is to be deplored that the clause in the Wilson bill relative to the duty on precious stones as amended has been passed. Should it become a law it will be disastrous to the entire jewelry industry in America, as well to the thousands of retailers and importers as to the handful of diamond cutters. It is to be sincerely hoped the Senators will look at the situation in this light.



### New York Notes.

Bartens & Rice have entered a judgment for \$462.19 against James H. Fish.

Sam Stern, of Sam Stern & Co., returns to-day from Chicago and the west.

William R. Alling is on a pleasure trip through the south. He will return about April 1st.

E. L. Anrich has entered a judgment for \$192.33 against Wm. Buch and Margaret E. Mackie.

Chas. R. Bassett has entered a judgment for \$4,218.91 against Wm. P. Conger, Lowville, N. Y.

Jos. Frankel's Sons have entered a judgment for \$1,368.43 against Moses J. Lichtenberg.

Jno. Scheidig & Co., 43 Maiden Lane, have applied for membership to the New York Jewelers' Association.

J. H. Masker, Jersey City, has given a bill of sale of jewelry fixtures to Amelia Nathan for a consideration of \$6,000.

Tchiboukdjian & Co., of Constantinople, the court jewelers of Turkey, have opened a New York branch at 1127 Broadway, near 25th St.

The offices of The Roy Watch Case Co., Hills & Whitbeck and F. A. Eastman & Co. have been removed from 17 Maiden Lane, to the Hays building, 21 Maiden Lane.

E. A. Haldiman, 33 Maiden Lane, who assigned Jan. 20th to Jno. J. Connolly, has effected a compromise with his creditors at 30 per cent. cash, and resumed business.

Theodore C. Steinhaus, formerly manager for S. C. Jackson, has started in business as a manufacturer of jewelry and silverware cases and trays, with an office and factory at 10 Maiden Lane.

J. A. Babcock & Co., manufacturers of silver plated ware, 404 Broadway, have dissolved. The business is continued by Wm. Tuscano, under the style of the Knickerbocker Mfg. Co.

The stock, fixtures, etc. of A. Walter & Son, Jersey City, have been transferred by a bill of sale to J. J. Murphy, and by him again to J. J. Murphy, Jr. and Juliana Walter. The consideration was \$1.

Mrs. Henry E. Droz died at her residence, 1825 Vanderbilt Ave., Tremont, Jan. 29th, aged 80 years. Mrs. Droz was the widow of the late Henry E. Droz, the well-known watch importer and jobber, at 92 Fulton St., who died Dec. 7th last.

The defendants, Jas. H. Noyes and the Bay State Watch Case Co., have demurred to the amended complaint of the Dueber Watch Case Mfg. Co. in the latter's suit in the United States Circuit Court against the manufacturers of watch cases and movements.

The New York Court of Appeals has dismissed the appeal of Allan C. Dalzell from the decision of the General Term of the Superior Court, which denied his motion to inspect the books of the Fahys

Watch Case Co., in his suit against that concern.

Pursuant to an order of Judge Pryor, of the Court of Common Pleas, Lorraine F. Dilleber, assignee of W. J. & C. I. Smith, 598 Broadway, is advertising for the creditors of that firm to present their claims to him, duly verified, at the office of E. A. Jacob, 320 Broadway, on or before April 11, 1894.

Chas. Newman was a prisoner in Essex Market Police Court last week on the charge of smashing the window of Nathan Lebowitz, jeweler, 140½ Pitt St., Jan. 29th, and stealing five watches. Newman, who was identified by Lebowitz, denied the charge, but Justice Hogan held him for trial in \$2,000 bail.

Wm. H. Ball & Co., 15 John St., have put their claim against the United States Express Co. into the hands of their attorney for settlement. It was by this express company that Wm. H. Ball & Co. recently sent the goods supposed to be ordered by A. Barth, of New Albany, Ind., which were delivered to a bogus A. Barth. Mr. Ball claims that the express company are liable for the loss.

Deputy Sheriff Burnes, Thursday, sold out the stock of Moses J. Lichtenberg, manufacturer of diamond jewelry at 64 John St., to satisfy an execution of \$6,033.11 in favor of Benj. G. W. Lichtenberg. The sale realized about \$1,200. Conveyances of real estate were recorded on Tuesday by Moses J. Lichtenberg to Benjamin Lichtenberg for a nominal consideration of property in 62d St., between Third and Lexington Aves., in First Ave., between 6th and 7th Sts., and a lot at Mount Hope and West Farms.

Chas. Taussig, dealer in jewelry, 226 E. 10th St., assigned Jan. 31st to Wm. N. Loew, lawyer, 233 Broadway, with preferences of \$2,432. The preferred creditors are: Mrs. Therese Taussig, \$850, and Louis Strasburger's Son & Co., \$1,582, for goods sold and delivered. The assignee estimates the assets at about \$2,500. The merchandise liabilities amount to \$4,632, as follows: L. Strasburger's Son & Co., \$1,582; Ernest Adler, \$900; Isaac Swope & Co., \$550; H. Z. & H. Oppenheimer, \$650; Providence Stock Co., \$95. A proposition to settle at 25 cents cash has been accepted by nearly all the creditors.

In the issue of Jan. 10th, mention was made of the decision of Judge Truax of the Supreme Court, in the suit of Tannenbaum vs. Armenia, in which the Judge decided that Mr. Tannenbaum was a partner of Mr. Armenia in connection with the Azure turquoise mine and other mines under a verbal agreement made on May 15th, 1892. Since this decision an application was made to Judge Truax by attorneys Otto Horwitz and M. M. Friend, who appeared for the defendant, for leave either to amend the answer by denying the partnership which through an oversight had not previously been done, or to allow the answer to be amended to

conform to the proofs of the trial. This was opposed by the plaintiff's attorney, Franklin Bien and Thursday Judge Truax denied such application, and judgment was filed Friday in the County Clerk's office adjudging the plaintiff and defendant co-partners and referring the accounting to Gilbert M. Speir, Jr., as referee.

### Depression in Real Estate Causes S. Dessau to Assign.

Simon Dessau, importer and dealer in drilling diamonds, carbon and bortz, 4 and 6 John St., New York, assigned Monday afternoon to Leon Lewin, a lawyer, giving the following preferences: Sophia Dessau, \$22,605.70, for money loaned; Amelia, David and Morris Dessau each, \$2,239.48, for money inherited by them from the estate of their grandfather and borrowed and used by the assignor; estate of Jos. Jessuran \$6,512 for money loaned; Hyman Israel \$12,800 on promissory notes; Hyman Israel \$10,000, to secure him on a bond; and Hyman Israel's Sons \$8,000 on promissory notes.

George W. Galinger, attorney for the assignee, said that the failure was caused by the general depression in real estate, the financial stringency and heavy losses by indorsements for other parties which they were unable to meet. Assignee Lewin later told a CIRCULAR reporter that the liabilities would probably reach \$250,000, and that he had not yet been able to get at any estimate of the assets. A large portion of the liabilities were secured.

The assets consist chiefly of real estate, merchandise and bills receivable. Of late years Mr. Dessau had gone very heavily into real estate speculation and had been putting up a number of big buildings on Broadway. The buildings at 759, 761, 753, 760, 762 and 764 Broadway, and 129 and 131 8th St., belonged to him. All this property, however, was mortgaged. Mr. Lewin said that the failure was due to the hard times and slack business. The carbon used for the steam drilling machines has had very little market lately owing to the closing of iron and marble mines all over the country. His real estate also was a very heavy burden to carry. The schedules would not be ready for several days, the assignee said.

Mr. Dessau commenced business in 1877. He had previously been a clerk for B. Spire. He was for a time at 4 Maiden Lane, and about ten years ago moved to his present quarters. At one time he dealt extensively in rough diamonds as well as bortz, and for some time was the sole importer of those materials in the city. He was also engaged in the cutting business, and was the cutter of the famous Cleveland gem. He gave up the cutting business about seven years ago. The assignee stated that at one time, Mr. Dessau controlled the output of Brazilian diamonds. Mr. Dessau is a widower. His wife was the daughter of Hyman Israel. He has six young children, some of whom are among his preferred creditors.





"GOELET CUP" FOR SCHOONERS.  
WON BY "VOLUNTEER."

**Solid Silver**  
Exclusively.



"GLORIANA CUP."  
CORINTHIAN YACHT CLUB.



**WHITING M'F'G Co.**

Silversmiths,

Broadway & 18th St.,

NEW YORK



COMMODORE OF THE LARCHMONT YACHT CLUB'S CUP  
FOR COMPETITION BY THE INTERNATIONAL CUP DEFENDERS OF 1893.







### Connecticut.

In Plainville Frederick Stevenson is building a shop on his lot to be used for manufacturing some parts of clocks.

C. J. Bates, bone and ivory goods manufacturer in Chester, has assigned; liabilities \$4,000; assets about the same.

The Meriden Silver Plate Co. completed last week a very handsome and artistic emblem in silver and gold for St. Elmo Commandery, Knights Templar, Meriden.

Waterbury Clock Co. at their annual meeting elected: Directors, H. L. Wade, A. S. Chase, Israel Holmes, I. H. Chase; president and treasurer, H. L. Wade, secretary, I. H. Chase.

Notices are posted in the Seth Thomas Clock Co.'s shops, Thomaston, that beginning Monday, Feb. 5th, the working hours will be from 7 A. M., to 6 P. M., making 10 hours, instead of 9½ as before.

The term of Jeweler Saxton, of New London, as Collector of the port of New London expires this month. He was appointed under President Harrison. He has been a very efficient official of Uncle Sam.

The annual meeting of R. Wallace & Sons Mfg. Co. was held Feb. 3d. F. A. Wallace was elected president, Col. W. J. Leavenworth treasurer, and H. L. Wallace secretary. The company declared their usual dividend.

The annual meeting of the E. A. Bliss Co. was held Feb. 1st when these officers were

elected: President, E. A. Bliss; secretary, and treasurer, C. E. Polsey; directors, George H. Wilcox, Samuel Dodd, E. A. Bliss and Deloss Bliss.

The building in which S. H. Kirby, New Haven and his father before him have done business for 40 years is soon to be torn down. Mr. Kirby has secured a store only a few doors from his old stand, to which he will remove in a few weeks.

At the annual meeting of the Rogers & Hamilton Co., Waterbury, the old board of directors and officers were re-elected: Directors, Charles A. Hamilton, William H. Rogers, A. M. Burritt, C. N. Wayland and W. H. Gaines; officers, Charles A. Hamilton, president and treasurer; W. H. Gaines, secretary.

The old-established jewelry firm of Hustace & Anderson, New London, successors to D. P. Hempstead, who had continued the business handed down by his father, was dissolved by Mr. Hustace retiring on the first of the month. Axel F. Anderson will continue the business.

At the annual meeting of the J. D. Bergen Co., Meriden, held Jan. 31, the following board of directors was elected: J. D. Bergen, E. J. Doolittle, W. R. Eliot, C. Berry Peets, C. P. Bradley, N. L. Bradley, C. E. Stockder, Jr.; auditors, C. E. Stockder, Jr., and Henry J. Vibert, Jr.

It is reported that a new factory for the manufacture of silver plated hollow ware is to be started in Wallingford soon, and is to

be managed by Henry E. Biggins, who has long held the position of superintendent of the Hartford Silver Plate Co. The necessary capital, it is said, has been offered Mr. Biggins.

President W. J. Miller, of the Derby Silver Co., announced to his employes Jan. 31st, that the works would be started the following morning and work is now in progress again at this establishment. A force will be employed in each department getting things in shape for a general resumption by a full force as soon as possible.

The inventory of the stock of Louis Hahn, New London, as returned to the probate court by the appraisers, amounts to \$13,880, to which will be added about \$4,000 of book accounts bringing the total of assets pretty near to the liabilities placed at \$21,000. Charles F. Starr and George Haven, trustees of the Louis Hahn estate, give notice that they are ready to dispose of the stock, fixtures, safe and street clock for any offer most advantageous to the estate.

At the annual meeting of Rogers & Brother, Waterbury, the following board of directors were chosen: D. B. Hamilton, Geo. C. White, Fred P. Wilcox, George Rockwell, George H. Wilcox, George N. Curtis, C. Berry Peets. F. P. Wilcox and C. Berry Peets were elected to fill the vacancies caused by the deaths of Isaac C. Lewis and George R. Curtis. The directors elected D. B. Hamilton president and treasurer, and George Rockwell secretary.

# THOMAS W. LIND,

MANUFACTURER OF

## Jewelers'

## Findings,

67 Friendship Street,

PROVIDENCE, R. I.

CALL OR SEND FOR SAMPLES OF MY NEW

## Rococco \* Patterns,

FOR PICTURE FRAMES, CANE HEADS, WHIPS, BOXES, NAPKIN RINGS, Etc.

Large Assortment of TRIMMINGS for Millinery

Ornaments, Scarf Pins, etc.



ROOSTERS  
AND OTHER  
ANIMAL FIGURES  
IN GREAT VARIETY.



Write us when  
you are in  
need of  
anything.

Ballet Dancers in Five Different Positions.



◆ Settings Made in Any Desired Thickness of Stock. ◆



# That Joyful Feeling \* \* \* \*

WILL BE EXPERIENCED BY EVERY DEALER WHO BUYS HIS

\* \* \* \* \*

## DIAMONDS, WATCHES, JEWELRY CHAINS, RINGS ETC.,

OF THE

### AIKIN-LAMBERT JEWELRY CO.,

19 Maiden Lane, New York.

WON'T THAT BE BETTER THAN THAT TIRED FEELING?

### WM. SMITH & CO.,

Manufacturers of Gold, Silver and Roll Plate Chains and Jewelry.



Novelties in Gold and Silver Bead Necklaces and Bracelets. Also a large line of Chain Trimmings and Silver Rings.

Office: 5 and 7 Maiden Lane, New York.      Manufacturing: 61 Peck Street, Providence, R. I.

OUR OWN ★

## "COLUMBIAN"

Fifty Punch Staking Tool, LEADS ALL OTHERS in STYLE, FINISH and ACCURACY. Hundreds of practical Watch Makers pronounce it the BEST.

Nickel frame, mahogany base, extra fine tempered steel punches and stumps.

—♦ FULLY WARRANTED. ♦—

For full description send five cents in stamps, with business card, for New Catalogue of OVER ONE THOUSAND varieties of fine Watch and Bench Tools of OUR OWN MAKE, many entirely new.

O. W. BULLOCK & CO.,  
SPRINGFIELD, MASS.

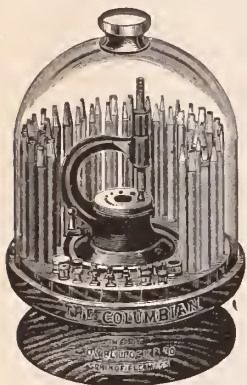

### Last Week's Arrivals.

*THE CIRCULAR* has perfected arrangements for obtaining the names and hotel addresses of all the latest buyers visiting New York, and each day posts in its office, 189 Broadway, a bulletin which every member of the trade is cordially invited to copy.

The following out-of-town dealers were registered in New York during the past week: S. Shuttle, Dallas, Tex.; Astor H., J. M. Harper, Philadelphia, Pa.; Astor H.; M. Garson, Rochester, N. Y.; Waldorf H.; M. Stern, Philadelphia, Pa.; Morton House; E. G. Lloyd, Scranton, Pa.; St. Denis H.; C. E. Child, Warren, R. I.; Astor H.; C. S. Davis, Philadelphia, Pa.; Astor H.; H. Eisenberg, Dives, Pomeroy & Stewart, Reading, Pa.; Broadway Central H.; George Topliff, St. Paul, Minn.; Chas. E. Crosby, J. S. Menken Co., Memphis, Tenn., 115 Worth St.; J. C. Seashols, Louisville, Ky.; Metropolitan H.; J. W. F. Podmore, Troy, N. Y.; St. Cloud H.; N. Galt, Washington, D. C.; Westminster H.; H. V. Gavigan, Doggett D. G. Co., Kansas City, Mo., 120 Franklin St.; J. B. Judson, Rochester, N. Y.; Hoffman H.; F. L. Fairchild, Mt. Vernon, N. Y.; Astor H.; G. B. Barrett, Pittsburgh, Pa.; Normandie H. Mrs. T. V. Dickinson, Buffalo, N. Y.; St. Denis H.; J. C. Lang, Boston, Mass.; Astor H.; J. Nelson, Dunkirk, N. Y.; St. Denis H.; P. J. Delahant, H. P. Warren & Co., Indianapolis, Ind., 335 Broadway; A. Kingsbacher, Pittsburgh, Pa.; Astor H.; M. Cohen, Washington, D. C.; Marlborough H.; J. A. Goldsmith, Washington, D. C.; Plaza H.; S. W. Bramley, Rondout, N. Y.; A. T. Maynard, of A. Stowell & Co., Boston, Mass.; Everett H.

## JUST OUT FOR 1894—"BEST MADE."



SINGLE BOXES, ASSORTED SIZES,

15 CENTS.

SINGLE BOXES, ASSORTED SIZES,

15 CENTS.

A Complete Assortment of Dial Washers of Every Size Used, Price 50 Cents.

FOR SALE BY

CROSS & BEGUELIN,

17 MAIDEN LANE,

AND TELL A. BEGUELIN, SUSSFELD, LORSCH & CO., HENRY ZIMMERN & CO., HAMMELL, RIGLANDER & CO., L. H. KELLER & CO., R., L. & M. FRIEDLANDER, H. H. KAYTON, FISHER & SONS, GREEN BROS., L. S. MEYER & BRO., NEW YORK, AND ALL FIRST-CLASS MATERIAL DEALERS THROUGHOUT THE COUNTRY.



# A NEW DEPARTURE IN WATCHMAKING.

## THE CHARMILLES WATCH

OPEN FACE, STEM WINDING, PENDANT SETTING, 16 SIZE, 3-4 PLATE, SOLID NICKEL MOVEMENT, 7 JEWELS, STRAIGHT LINE LEVER ESCAPEMENT; CASED IN NICKEL AND STEEL, PLAIN AND ORNAMENTED.



NO. 5, NICKEL,  
OLD SILVER FINISH,  
APPLIED DESIGN.



NO. 1, NICKEL,  
PLAIN POLISHED.



NO. 4, NICKEL,  
OLD SILVER FINISH.

GUARANTEED  
PERFECT  
TIMEKEEPERS.

THE advent of the "CHARMILLES" marks a new era in the construction of watches. Heretofore the "movement" and "case" have been two distinct and separate pieces. In the "CHARMILLES" watch they are one and the same thus permitting a HIGHER QUALITY MOVEMENT at the expense of the case. The stem-winding and pendant hand setting mechanism is extremely simple, durable and positive, and is a feature of the watch. The "CHARMILLES" is not a cheap watch, but a finely finished nickel movement, cased in its simplest form, and sold at a LOW PRICE.

Practical watchmakers are delighted with its construction and practical advantages, and watch merchants charmed with its appearance and selling points. No low-priced watch in the market can compare with the "CHARMILLES." It is the watch of the times—the greatest value for the least money.

THOROUGHLY  
NON-MAGNETIC.



NO. 7, STEEL,  
BLACK OXYDIZED,  
SILVER DESIGN.

For Sale by leading Jobbers and carried by progressive traveling salesmen. Write your jobber for a sample or inquire of traveling salesmen.

DO NOT BE WITHOUT THEM.



NO. 8, STEEL,  
BLACK OXYDIZED,  
GOLD DESIGN.

# Special Announcement.



## L. TANNENBAUM & Co.,

IMPORTERS AND CUTTERS OF

### Diamonds and Precious Stones,

Cor. Maiden Lane & Nassau St.,

NEW YORK.

TELEPHONE,  
Long Distance,  
1959 CORTLANDT

25 HATTON GARDEN,  
LONDON.

**W**E desire to inform the trade that we have to-day the finest and largest stock of all kinds of **COLORED STONES**, of all **QUALITIES**, in all **SIZES** and at all **PRICES**, suitable for **MANUFACTURERS**, **JOBBERS** and **RETAILERS**. Also a particularly handsome and large stock of **DIAMONDS**, fine **FANCY DIAMONDS** and **DIAMOND JEWELRY**, **ROUGH RUBIES** and **ROUGH CEYLON FANCY SAPPHIRES** of all kinds, for Cutters' use, also **ROUGH SAPPHIRES** for **MECHANICAL PURPOSES**.

In order to reduce our enormous stock, we propose to sell at **VERY LOW PRICES**, giving a **SPECIAL DISCOUNT FOR CASH**. Orders by mail, or telephone, 1959 Cortlandt, will receive prompt attention. We desire the trade also to note particularly our next week's advertisement, in which we shall quote at SPECIAL FIGURES, some of our numerous parcels of precious stones of every kind, in fine and in medium qualities, thus enabling buyers everywhere to take advantage of our unprecedented offers.

Respectfully,

**L. TANNENBAUM & CO.**



## News Gleanings.

Geo. W. Fink, Greeley, Col., has sold out.

Frederick A. Bach, Catskill, N. Y., has sold out.

J. P. Cook will open a jewelry store in Mt. Blanchard, O.

S. Malmberg, Ashland, Wis., has gone out of business.

C. S. Sands, Albia, Ia., has given a chattel mortgage for \$1,600.

Holch Bros., 29 W. Superior St., Duluth, Minn., have assigned.

Johnson Bros., Spencer, Ind., have been succeeded by O. H. Johnson.

Beirlie & Helvy have succeeded Mrs. S. W. Brock, Hamilton, O.

A. S. Keeler, Marion, O., has opened a branch in Green Camp, O.

S. Rosenfeld, Atlanta, Ga., has sold out his business to C. Kaufman.

A. J. Gager, Cleveland, O., has given a chattel mortgage for \$1,833.

F. F. Shaw, Manchester, N. H., has mortgaged real estate for \$2,000.

W. F. Parker, Fair Haven, Vt., has removed to a new location in that town.

Moffitt & Monroe, Southbridge, Mass., have given a chattel mortgage for \$1,400.

Executions were entered last week against A. M. Bronson, Susquehanna, Pa., for \$9,187.

The sheriff has sold out the stock of V. S. Pruner, New Whatcom, Wash., to S. Pruner.

M. Berkele, of Maier & Berkele, Atlanta, Ga., has given real estate deeds aggregating \$1400.

William Gibson, Hagerstown, Md., announces that he intends to retire from business.

Jesse Strauss, aged 11 years, son of Simon Strauss, jeweler, Belleville, Ill., died Jan. 29th.

Harry E. Thomas, Wilmington, Del., has just returned from a business trip in Pennsylvania.

The Haley Mfg. Co., Concord, N. H., makers of shade rollers, wire and clock springs, have assigned.

Burglars stole about \$100 worth of goods from the A. Craig Voorhees' store, New Brunswick, N. J., last week.

George W. Lowe, jeweler, Lewes, Del., and Miss Lulu M. Kelley, late of Oil City, Pa., were married last week.

Robert Streblau, Tom's River, N. J., has removed his jewelry establishment from the Wissmach building to a Main St. store.

Chas. Hopkins, Marysville, O., has sold his jewelry store to C. F. Sellers and J. W. Hopkins, who will continue the business.

J. A. Sisk, who on Jan. 6, robbed the jewelry store of J. W. Stallcup, Shreveport, La., was captured last week at Greenville, S. C.

The sheriff is in possession of the jewelry store of O. A. Prairie, Altoona, Pa., who bought out M. H. Fenno, on July 19, last.

In a destructive fire in Lynn, Mass., a few days ago, the jewelry business of T. P. Ford was damaged to the extent of \$1,000; insured.

The Nevada State Prison inmates are getting up an exhibit for the Mid-Winter Exposition, to consist of inlaying, jewelry work, etc.

Joseph Lodomus, Chester, Pa., is building an addition to his store room, 25x20 feet in dimensions. The extension will be used for an optical department.

John A. Tschantre, Cambridge, Md., has made application for the benefit of the insolvency laws, naming Thomas W. Simons, as preliminary trustee.

Miss Gertrude Smith, daughter of cashier Carlos M. Smith, of the Elgin National Watch Co., Elgin, Ill., was married to Harry W. Adams, of Chicago, last week.

J. C. Hueter, a jeweler living at 1618 St. Clair St., Cleveland, O., was arrested last week on the charge of assault and battery, and locked up. He was released on bail.

O. L. Rosenkrans, head of the O. L. Rosenkrans & Thatcher Jewelry Co., Milwaukee, Wis., is an active candidate for the nomination for Secretary of State on the Republican ticket next Fall.

D. Tobias, who started at 917 12th St., Washington, D. C., moved on Feb. 1st to No. 1307, and is putting in a large line of goods. Mr. Tobias learned his trade in Europe and is a skilful bench man.

A fire occurred in the basement of W. E. Chamberlain's jewelry store, Great Falls, Mon., a few mornings ago; the damage to the building was trifling; loss on the stock was \$500, fully covered by insurance.

The K. H. Clarke Jewelry Co. have filed articles of incorporation at St. Joseph, Mo. The capital stock is \$10,000, all paid up. C. R. Millen, of Keokuk, Ia., owns 43 shares; K. H. Clarke, 48 shares, and A. B. Augston nine shares.

Chas. Banks, who recently opened a jewelry store on E. 7th St., Wilmington, Del., has removed to Thos. Sherwin & Sons' old stand on Market St. Mr. Sherwin will still continue to do engraving in the rear of Mr. Banks' store.

The trial of the indictments against T. H. Aymes, the man who robbed Charles S. Stiff, Little Rock, Ark., has been, at the request of defendant's attorney, continued and set for March 6. There are two charges, one for robbery and the other false pretenses.

L. E. Waldorf, jeweler, Wolcott, N. Y., met with a painful accident while skating last week. He collided with another skater. Mr. Waldorf was picked up bleeding from the nose and mouth. He was found to have sustained a dislocated shoulder, and his nose was crushed in.

The jewelry store of C. Parisio & Co., Hazleton, Pa., was closed Saturday morning by Sheriff Walters on judgment of David Davidow. Parisio also conducted a private banking business, patronized by Italians, and his embarrassment has caused consternation among that class.

## Louisville.

N. Cerf & Son, jewelers and pawnbrokers, recently removed to 75 E. Market, corner 3d St.

Four gold watches valued at \$407 were stolen from Frank Mettler, a jeweler, 1036 W. Market St., late Wednesday afternoon. The watches were afterward recovered and the thief captured in New Albany in the act of selling the timepieces. The thief gave his name as James Smith.

John E. Routh, who for the past three years has been conducting a jewelry establishment at 49 Spring St., Jeffersonville, has been compelled to close his doors. Veit Hirsch & Co., New York, levied on Routh's stock, and this precipitated an assignment. The assets and liabilities are comparatively small. Mr. Routh thinks he will be able within a short time to settle his difficulties.

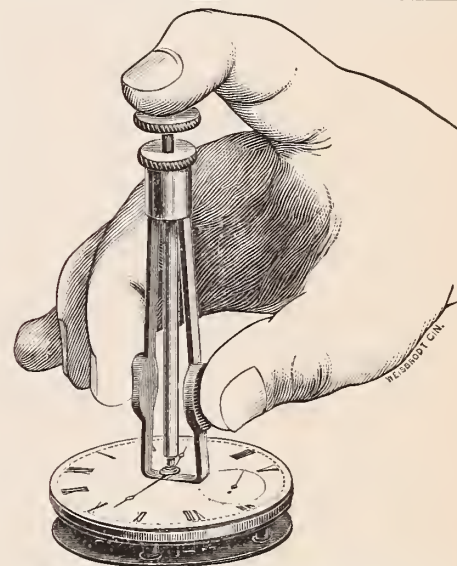

The Most Practical D. & M. Hand Remover  
in the market for \$1.00.

**JOS. MEHMERT,**  
**Jewelers' Supply Store,**  
**CINCINNATI, OHIO.**

**AWARD AT WORLD'S FAIR, CHICAGO, 1893**

**The Providence Shell Works.**  
**W. K. Potter,**  
346 Westminster St., Providence, R. I.



**Tortoise Shell Goods, Combs, Hair Orna-  
ments, Jewelry, Etc.**  
Shell Work made to order on contract. Repairing for  
the trade in all its branches.



CLASSIFIED INDEX TO ADVERTISEMENTS.

All Advertisements are entitled to one insertion under proper heading. Extra insertions, \$6.00 per annum. Extra Headings, \$12.00 per annum.

**Art Pottery, Bric-a-brac, Etc.**  
 Ahrenfeldt, Charles & Son, 50-52-54 Murray St., N. Y. .... 110  
 Bing, Ferdinand & Co., 106 Grand St., N. Y. .... 106  
 Borgfeldt, Geo. & Co., 18, 20 & 22 Washington Place, New York ..... 109  
 Glaenger, Leon J. & Co., 80-82 Chambers St., N. Y. .... 74  
 Haviland & Abbot, 29 Barclay St., N. Y. .... 111  
 Hinrichs & Co., 29 & 31 Park Place, N. Y. .... 112  
 Levy, Dreyfus & Co., 9-11 Maiden Lane, N. Y. .... 112  
 Straus, L. & Sons, 42 to 48 Warren St., N. Y. .... 105  
 Vantine, A. A. & Co., 877-79 Broadway, N. Y. .... 108

**Assayers & Refiners.**  
 Clark, J. L., Philadelphia, Pa. .... 112  
 Goldsmith Bros., Chicago, Ill. .... 40  
 Howard, S. P., 33 Maiden Lane, N. Y. .... 140  
 Le Long, L. & Bro., Newark, N. J. .... 140  
 Rathbone, J., Providence, R. I. .... 128  
 Schawel, J. & Co., 29 John St., N. Y. .... 140

**Auctioneers.**  
 American Syndicate of Jewelry Auctioneers, New York and Washington ..... 120  
 French, J. H., P. O. Box 2775, N. Y. .... 112  
 Prince, J., 137 Broadway, N. Y. .... 140  
 Rich, H. M. & Co., Boston, Mass. .... 118  
 Scott, De B. O., 20 Murray St., N. Y. .... 87

**Badges, Medals, Etc.**  
 Irons & Russell, Providence, R. I. .... 126  
 Schlechter, G. A., Reading, Pa. .... 119  
 Stockwell, E. R., 19 John St., N. Y. .... 5  
 Willson, Chas. G., Reading, Pa. .... 126

**Chromometers.**  
 Bliss, John W., & Co., 129 Front St., N. Y. .... 90

**Chrome Steel.**  
 Chrome Steel Works, Brooklyn, N. Y. .... 140

**Clocks.**  
 Evans, W. F., & Son, Birmingham, Eng. .... 127  
 The F. Kroeber Clock Co., 360 Broadway, N. Y. .... 76  
 The Ansonia Clock Co., 11 Cliff St., N. Y. .... 79

**Clocks, French, English and American.**  
 Jacques, Chas., Clock Co., 22 Cortlandt St., N. Y. .... 140

**Cut Glass.**  
 Mt. Washington Glass Co., New Bedford, Mass. .... 118

**Diamond Cutters and Importers.**  
 Humphrey, J. B., Boston, Mass. .... 54  
 Stern Bros. & Co., 30 Maiden Lane, N. Y. .... 52

**Diamond & Precious Stone Importers.**  
 Azure Mining Co., 41-43 Maiden Lane, N. Y. .... 37  
 Disselkoe, John N., 19 E. 10th St., N. Y. .... 118, 120, 121, 123  
 Eichenberg, Julius, Providence, R. I. .... 120  
 Essig, Frank J., Chicago, Ill. .... 130  
 Falkenan, Oppenheimer & Co., 40 Maiden Lane, N. Y. .... 140  
 Fera, Henry, 10 Maiden Lane, N. Y. .... 112  
 Fox, Gustave & Co., Cincinnati, O. .... 137  
 Hedges, Wm. S. & Co., 170 Broadway, N. Y. .... 122  
 Jonas, Doist & Co., Cincinnati, O. .... 136  
 Juergens & Andersen Co., Chicago, Ill. .... 132  
 Kipling, R. A., Hays Bldg., N. Y. .... 122  
 Kipling, E. E., 182 Broadway, N. Y. .... 140  
 Koch, Dreyfus & Co., 22 John St., N. Y. .... 128  
 Lorsch, Albert & Co., 37 Maiden Lane, N. Y. .... 140  
 Nissen, Ludwig & Co., 18 John St., N. Y. .... 122  
 Noterman, Jos., & Co., Cincinnati, O. .... 136  
 Randel, Baremore & Billings, 29 Maiden Lane Rothschild, M. D., 41 & 43 Maiden Lane, N. Y. .... 140  
 Smith, Alfred H. & Co., 182 Broadway, N. Y. .... 122  
 Tannenbaum, L., & Co., cor. Maiden Lane and Nassau St., N. Y. .... 100  
 Tatch & Wild, Chicago, Ill. .... 134  
 Wheeler, Hayden W., & Co., 2 Maiden Lane, N. Y. .... 118

**Ebony and Silver Goods.**  
 Provenzano, J. N., 39 Union Square, N. Y. .... 65

**Engravers.**  
 Field & Beattie, Fulton St., N. Y. .... 104

**Fine Stationery.**  
 Parsons & Greene Co., 18 Murray St., N. Y. .... 13

**Gold and Silver Novelties.**  
 Cottle, S., & Co., Jackson Building, Union Sq., N. Y. .... 84

**Gold and Silver Plating Works.**  
 Bolstad Mfg. & Plating Co., Chicago, Ill. .... 136  
 Empire Gold and Silver Plating Works, 75 & 77 Nassau St., N. Y. .... 90  
 Ternandt, Wm., Chicago, Ill. .... 143

**Gold Jewelry.**  
 Battin & Co., Newark, N. J. .... 12  
 Bippart & Co., Newark, N. J. .... 33  
 Carter, Sloan & Co., 15 Maiden Lane, N. Y. .... 123  
 Chatterlier, Jas. F., 860 Broadway, N. Y. .... 9  
 Day & Clark, 23 Maiden Lane, N. Y. .... 37  
 Hayden Mfg. Co., Newark, N. J. .... 120  
 Herzog, J., & Co., 8 Maiden Lane, N. Y. .... 128  
 Hook, G. W., Chicago, Ill. .... 134  
 Johnson, R. M., 67 Washington St., Chicago, Ill. .... 23  
 Kremenz & Co., 182 Broadway, N. Y. .... 69

**Larter, Elcox & Co., 21 & 23 Maiden Lane, N. Y. .... 127**  
 Mandeville, Carrow & Crane, Newark, N. J. .... 120  
 Pfeil, Chas. H., Chicago, Ill. .... 132  
 Richardson, Enos, & Co., 23 Maiden Lane, N. Y. .... 117  
 Reeves & Sillocks, 19 Maiden Lane, N. Y. .... 22  
 Schwartz, W. H., & Co., Newark, N. J. .... 120  
 Spencer, E. L. & Co., Providence, R. I. .... 62  
 Street, Geo. O. & Sons, 15 John St., N. Y. .... 88  
 Uhry, Chas. L., & Co., Newark, N. J. .... 120  
 Unger Bros., 192 Broadway, N. Y. .... 38  
 Waite, Thresher & Co., Providence, R. I. .... 139  
 Webster, G. A., Chicago, Ill. .... 134

**Gold and Rolled Plate Jewelry.**  
 Foster & Bailey, Providence, R. I. .... 23  
 Read, M. L. & Co., Providence, R. I. .... 88  
 Smith, Wm., & Co., 5-7 Maiden Lane, N. Y. .... 98

**Horological Schools.**  
 American Horological Institute, Lancaster, Pa. .... 118  
 Chicago Watchmakers' Institute, Chicago, Ill. .... 134  
 Elgin Horological school, Elgin, Ill. .... 136  
 Parson's School for Watchmakers, Peoria, Ill. .... 136  
 Waltham Horological School, Waltham, Mass. .... 118

**Hotels.**  
 Gibson House, Cincinnati, O. .... 136

**Imported Show Cases.**  
 Fletcher Mfg. Co., 259 W. 27th St., N. Y. .... 92

**Jewelers' Findings.**  
 Lind, Thos. W., Providence, R. I. .... 98

**Jewelry Mailing Boxes.**  
 Am. Railway Supply Co., 24 Park Place, N. Y. .... 137

**Jewelers' Insurance.**  
 The Jewelers' League, New York. .... 124

**Jewelry, Silverware and Optical Cases.**  
 Borgzinner, S. A., 82-84 Nassau St., N. Y. .... 56  
 Hebbard & Bro., 860 Broadway, N. Y. .... 60  
 Jackson, S. C., 180 Broadway, N. Y. .... 86  
 Steinhau, Theo. C., 10 Maiden Lane, N. Y. .... 37  
 Schwarz, A., 860 Broadway, N. Y. .... 128  
 Froescher, A. & Co., 69 Nassau St., N. Y. .... 91

**Jobbers, Watches, Diamonds, Etc.**  
 Aikin-Lambert Jewelry Co., 19 Maiden Lane, N. Y. .... 121  
 Albert Bros., Cincinnati, O. .... 137  
 Amberg & Goldberg, Cincinnati, O. .... 137  
 Becken, A. C., Chicago, Ill. .... 134  
 Bell, O. E. & Co., Cincinnati, O. .... 136  
 Bene, Lindenber & Co., Cincinnati, O. .... 136  
 Brethauer Watch & Jewelry Co., Chicago, Ill. .... 134  
 Conover, David F. & Co., Philadelphia, Pa. .... 57  
 Cross & Bequelin, 17 Maiden Lane, N. Y. .... 117  
 Friedlander, R. L. & M., 65, 67 Nassau St., N. Y. .... 56  
 Happel, C. F. & Co., Chicago, Ill. .... 130  
 Hellebush, Clemens, Cincinnati, O. .... 134  
 Lapp & Flerhem, Chicago, Ill. .... 36  
 Lissauer & Co., 12 Maiden Lane, N. Y. .... 89  
 Mehmert, Jos., Cincinnati, O. .... 101  
 Noss, S. F. & Co., 48 Maiden Lane, N. Y. .... 140  
 Norris, B. F., Alister & Co., Chicago, Ill. .... 133  
 Oppenheimer Bros. & Veith, 35 Maiden Lane, N. Y. .... 88  
 Purdy, J. N. & Co., Chicago, Ill. .... 134  
 Oskamp, Nolting & Co., Cincinnati, O. .... 135  
 Rosenfeld, Wm., 24 Maiden Lane, N. Y. .... 25  
 Schwab, A. G., Cincinnati, O. .... 135  
 Scott, J. T. & Co., 4 Maiden Lane, N. Y. .... 33  
 Voss, Jos. S. & Son, Cincinnati, O. .... 130  
 Wiggers & Froetich, 60 Nassau St., N. Y. .... 121

**Leather and Silver Goods.**  
 Deitsch Bros., 7 E. 17th St., N. Y. .... 87

**Musical Boxes.**  
 Jacot & Son, 298 Broadway, N. Y. .... 126  
 Wolf, A., 104 Broadway, N. Y. .... 90

**Miniature Photographs.**  
 Favre, Leon, 107 E. 26th St., N. Y. City. .... 88

**Optical Goods.**  
 Berger, Albert & Co., 47 Maiden Lane, N. Y. .... 104  
 Geneva Optical Co., Chicago, Ill. .... 126  
 Kirstein's, H. E., Sons Co., Rochester, N. Y. .... 117  
 Scheidig, John, 43 Maiden Lane, N. Y. .... 128  
 Queen & Co., Philadelphia, Pa. .... 117  
 Winsted Optical Co., Winsted, Conn. .... 127

**Office Building.**  
 Cruikshank, E. A. & Co., 176 Broadway, N. Y. .... 117  
 Diamond Exchange Building, 14 Maiden Lane. .... 119  
 Duncan, W. B. J., 815 Havemeyer Building, N. Y. .... 119

**Optical Schools.**  
 The Chicago Ophthalmic College, Chicago, Ill. .... 132

**Paneled Metal.**  
 Northrop & Co., Pittsburgh, Pa. .... 126

**Pens, Pencil Cases, Etc.**  
 The Boston Pen Co., Boston, Mass. .... 88  
 Aiken-Lambert & Co., 19 Maiden Lane, N. Y. .... 98

**Patents.**  
 Belt, C. T., Washington, D. C. .... 117

**Platinum Importers.**  
 Schawel, J. & Co., 29 John St., N. Y. .... 140

**Ring Makers.**  
 Bryant, M. B. & Co., 10 Maiden Lane, N. Y. .... 87  
 Bowden, J. B. & Co., 192 Broadway, N. Y. .... 127

**Haskell, H. C., Corbin Building, N. Y. .... 91**  
 Hildreth Mfg. Co., 51 Maiden Lane, N. Y. .... 74  
 Wood, J. R. & Sons, New York. .... 10

**Rubber Stamps and Type.**  
 Dietz, Wm. H., Chicago, Ill. .... 32

**Sample Trunks.**  
 Crouch & Fitzgerald, 161 Broadway, N. Y. .... 119

**Silver Deposit Ware.**  
 Alvin Mfg. Co., 860 Broadway, N. Y. .... 34

**Silver Mounted Ebony Goods.**  
 Deitsch Bros., 7 E. 17th St., N. Y. .... 87

**Silver Plated Ware.**  
 Adelphi Silver Plate Co., 62 John St., N. Y. .... 96  
 Aurora Silver Plate Mfg. Co., Aurora, Ill. .... 32  
 Meriden Britannia Co., Meriden, Conn. .... 10-11  
 Pairpoint Mfg. Co., New Bedford, Mass. .... 9  
 Rogers, Smith & Co., Meriden, Conn. .... 76  
 Rogers & Bro., 16 Cortlandt St., N. Y. .... *Inside Back Cover.*

**The Holmes & Edwards Silver Co., Bridgeport, Conn. .... 22**  
 The Rogers & Hamilton Co., Waterbury, Conn. .... 51  
 The Wm. Rogers Mfg. Co., Hartford, Conn. .... 70

**Specialties in Jewelry.**  
 Warren & Co., Hadlyme, Conn. .... 136

**Sterling Silver Novelties.**  
 Bachrach & Freedman, 1 & 3 Union Sq., N. Y. .... 128  
 Merrill Bros., 31 E. 17th St., N. Y. .... 127

**Sterling Silverware.**  
 Campbell-Metcalf Silver Co., Providence, R. I. .... 140  
 Dominick & Hoff, Broadway & 17th St., N. Y. .... 5  
 Gorham Mfg. Co., Broadway & 19th St., N. Y. .... 2-3  
 Knowles, J. B. & S. M. Co., Silversmiths' Hall, Union Square, N. Y. .... 47  
 Krider, Peter L., Co., Philadelphia, Pa. .... 44  
 Reed & Barton, 37 Union Square, N. Y. .... 131  
 Shiebler, Geo. W., Co., 179 Broadway, N. Y. .... 48  
 Towle Mfg. Co., Newburyport, Mass. .... 43  
 Wallace, R. & Sons Mfg. Co., 3 Park Place, N. Y. .... *Back Cover.*

**Whiting, F. M., North Attleboro, Mass. .... 80**  
 Whiting Mfg. Co., Broadway & 18th St., New York. .... 95  
 Wood & Hughes, 10 John St., N. Y. .... 104

**Spectacle and Eyeglass Cases.**  
 Birmingham, Wm. & Co., 728 Arch St., Phila. .... 140  
 White, W. B. & Son, Boston, Mass. .... 120

**Stem Winding Attachments.**  
 Abbott, Henry, 2 Maiden Lane, N. Y. .... 140

**Show Cases.**  
 Smith, B. & W. B., 220 W. 29th St., N. Y. .... 113

**Thimbles.**  
 Ketcham & McDougal, 198 Broadway, N. Y. .... 126

**Tissue Paper.**  
 Dexter, C. H., & Sons, Windsor Locks, Conn. .... 87

**Tortoise Shell Goods.**  
 Potter, W. K., Providence, R. I. .... 101  
 Rice & Hochster, 483-5 Broadway, N. Y. .... 15

**Tool Manufacturers and Dealers.**  
 American Watch Tool Co., Waltham, Mass. .... 119  
 Bealmeare, H., Baltimore, Md. .... 61  
 Bullock, O. W. & Co., Springfield, Mass. .... 98  
 Gesswein, F. W., 39 John St., N. Y. .... 56  
 Glickauf & Newhouse, Chicago, Ill. .... 26  
 Harding Bros., Chicago, Ill. .... 132  
 Logan, A. J., Waltham, Mass. .... 127  
 Moseley & Co., Elgin, Ill. .... 132  
 Muehlhant, Hedges & Co., Cincinnati, O. .... 137  
 Oliver, W. W., Buffalo, N. Y. .... 135  
 Swartzchild & Co., Chicago, Ill. .... 28

**Trunks and Traveling Bags.**  
 Crouch & Fitzgerald, 161 Broadway, N. Y. .... 119

**Watch Manufacturers.**  
 American Waltham Watch Co., 21 Maiden Lane, N. Y. .... 14  
 Charmilles Watch, N. Y. .... 99  
 Illinois Watch Co., Corbin Building, N. Y. .... 29

**Watch Case Manufacturers.**  
 Bates & Bacon, 11 John St., N. Y. .... 29  
 Duhme Co., Cincinnati, O. .... 135  
 Margot Bros., Boston, Mass. .... 120  
 The Planchamp & Becker Co., Chicago, Ill. .... 134

**Watch Case Material.**  
 The Newark Watch Case Material Co., Newark, N. J. .... 66  
 Poltock, A., 17 Maiden Lane, N. Y. .... 98

**Watch Dials.**  
 O'Hara Waltham Dial Co., Waltham, Mass. .... 119

**Watchman's Clocks.**  
 Hausburg, O. E., 41 Maiden Lane, N. Y. .... 103

**Watch Importers.**  
 Abry, Chas. Leo, 41-43 Maiden Lane, N. Y. .... 56  
 Beguelin, Tell A., 71 Nassau St., N. Y. .... 117  
 Hyde's, J. E., Sons, 22 Maiden Lane, N. Y. .... 121  
 Mathey Bros., Mathez & Co., 21 & 23 Maiden Lane, N. Y. .... 88  
 Wittnauer, A., 19 Maiden Lane, N. Y. .... 83

**Watch Keys.**  
 Clark, A. N., Plainville, Conn. .... 87

**Watch Repairers.**  
 Henry, Peter, Cincinnati, O. .... 136  
 Muller, Hugo, Chicago, Ill. .... 132



## Special Notices.

Rates 75c. per insertion for notices not exceeding 3 lines (25 words); additional words 2 cents each. If answers are to be forwarded, postage stamps must be enclosed. Two insertions, 15 per cent. off; three insertions, 20 per cent. off; four insertions or more, 25 per cent. off. Payable strictly in advance. Display cards on this page will be charged at \$2.00 per inch for first insertion, subject to same discount above for subsequent insertions.

Under the heading of **Situations Wanted** on this page advertisements will be inserted for **One Cent a Word**. This offer refers to **Situations Wanted only**. Payable strictly in advance. If answers are to be forwarded, postage must be enclosed.

## Situations Wanted.

Notices under this heading **ONLY** are charged at one cent a word, payable strictly in advance. If answer are to be forwarded, postage must be enclosed.

**WANTED**—A position by a first-class manufacturing jeweler and diamond setter. Also lapidary of all kinds of precious stones; 22 years' experience at the bench; will take entire charge of a shop, large or small. Address S. C. M., care JEWELERS' CIRCULAR.

**A JEWELER** wants position with a wholesale or retail store, to take charge of shop, making and repairing. Address Metallurgist, care JEWELERS' CIRCULAR.

**WANTED**, a position in factory or as traveling salesman by a gentleman of 25 years' experience in the plain gold ring business. Address "H," care of JEWELERS' CIRCULAR.

**SITUATION** wanted by a young man; two and a half years' experience in a retail store. Address R. T., care JEWELERS' CIRCULAR.

**WANTED, SITUATION**—Manager of a business for two years past. Do all branches of work—watchmaking, engraving, seal making, jobbing, selling, buying. Box 695, What Cheer, Ia.

**A PRACTICAL** jeweler, single man, desires position with a wholesale or retail store to take charge of manufacturing and repairing department. West or south preferred. Address T. R. W., care JEWELERS' CIRCULAR.

**SITUATION** wanted by diamond setter on rich diamond jewelry or watch cases; also designing; 10 years' experience; best of references. J. C. H., care JEWELERS' CIRCULAR.

**POSITION** wanted by young man as assistant entry clerk. Unquestionable references. Address "W. C.," care JEWELERS' CIRCULAR.

**WANTED**—A position in a wholesale jewelry house. Have had 10 years' experience in every department of a wholesale house. Am 29 years of age, and can furnish references. Address S. S. H., JEWELERS' CIRCULAR.

**SITUATION** wanted by a watchmaker, clock and jewelry repairer; single man; eight years' experience; have lathe and other tools; reference from present and former employer. Address Ed. S., Dresden, Ohio.

**AS** watchmaker and engraver. Good set of tools, lathe, etc. Experienced on complicated and difficult watchwork. Will send sample of engraving. Salary \$20 per week. Address "Boracs," care JEWELERS' CIRCULAR.

**WANTED**—Correspondence with responsible jewelry firm needing a first-class watchmaker commanding a good salary. For years manager of repair departments; well-educated; good address; sober; honest; reliable; a hard worker; A1 references. No engraver; no solderer. Address "Permanent," care JEWELERS' CIRCULAR.

**SITUATION WANTED** by watchmaker who thoroughly understands his business. Competent on chronographs and French clocks. Does all kinds of jewelry repairing. Good salesman. Address "Energetic," care JEWELERS' CIRCULAR.

**SALESMAN**.—Young man 23 years, wants position; acquainted with wholesale and retail jewelry trade; salary moderate. A. L. H., care JEWELERS' CIRCULAR.

**SITUATION** wanted by young man as engraver and assistant watchmaker; can give sample of work and good references. Address O. Grospietsch, care C. B. Jacquemin & Co., Council Bluffs, Ia.

**YOUNG MAN**, single, age 23, wishes situation either in Maryland, W. Virginia, Virginia, North or South Carolina, or Georgia, as watchmaker, jewelry jobber and plain engraver. Sample of work furnished. Good references. Address Southern, care JEWELERS' CIRCULAR.

**GOOD WATCHMAKER**, capable of doing all work, such as comes to a first class store, and who can take entire charge. American; age 36 years; married. Owns tools and bench. New England preferred. Permanent place desired, with a square dealing man. Address F & A. M., care of JEWELERS' CIRCULAR.

**WATCHMAKER**, who has had 13 years' experience at bench, wants a steady situation. Can do any kind of repairing and jobbing, or will take charge of jewelry stock. Can give A1 references. Address Lock Box 756, Eureka Springs, Ark.

**GOOD ENGRAVER**, age 25, can repair clocks and watches. Will send sample of engraving. Best of references. Address D. T., care JEWELERS' CIRCULAR.

## Help Wanted.

**WANTED**—By a jobbing house, a first-class city salesman. Address H. B. & Co., JEWELERS' CIRCULAR.

## To Let.

**TO LET**—Part of office or desk room. 198 Broadway, Room 5.

**BROADWAY STORE**, near Post Office. Half store and one window. Lease. 2 Astor House, New York.

## Miscellaneous.

**I BUY JEWELRY STOCKS**—Manufacturers, jobbers and retailers desiring to dispose of surplus or entire stocks of diamonds, watches and jewelry can find quick cash buyer by addressing Stephen S. Harmon, 134 East 96th St., New York City.

## DEMAGNETIZING.

**PERFECT WORK**—Watch repairing in all its branches; all work warranted. Winslow & Penney, 608 Masonic Temple, Chicago.

**FOURTEEN** karat gold solder that will flow on eight karat work; makes a hard solder job a pleasure. With this solder there is no danger of melting low karat specs. No white joints on rings. It is just what you want. Sample by mail 25 cents. F. W. Hall, Sterling Silver Novelties, Columbus Memorial Building, Chicago, Ill.

**SEND** for new 1894 prospectus of Trowbridge's Engraving School. Lowest terms of any school. Board \$12 to \$15 per month. Winona, Minn.

**COMPLETE** instructions how to conduct legal watch and jewelry clubs for \$2. A new system by which jewelers can largely increase their sales. Address The O. S. Judd Jewelry Co., Anderson, Ind.

**WANTED**—PARTNER with \$3,000 to \$4,000 to assume half interest in old established jewelry and stationery business. The leading store in a fast growing town; population 6,000. Am satisfied business can be increased with a live partner. Want a thorough business man, and would prefer an engraver and optician. The other part of the business I understand thoroughly. Every facility for investigation will be given. Call or address A. F. Robbins, Orange, Mass.

## For Sale.

**FOR SALE**—Shop, well equipped for the manufacture of diamond mountings; very reasonable; call between 12 and 2 P.M. I. Stern, 69 Nassau St., New York.

**FOR SALE**—At a bargain, tools, fixtures, and stock of old-established, well-paying jewelry store, in live Pennsylvania town. \$1,200 buys complete. Ill health reason for selling. It will pay you to write for particulars if you mean business. Address "Eugene," care JEWELERS' CIRCULAR.

**FOR SALE**.—A first class polishing lathe; all in good repair, at a low price for cash. Address G. W. Brown, 113 Point St., Providence, R. I.

**FOR SALE**—A nice jewelry store in a town of 25,000; best location; small stock; low rent; 30 miles from New York. About \$3,000,—can reduce to \$2,000 or less. Owner has other business. A bargain. Address A. C. V., care JEWELERS' CIRCULAR.

## Offices To Let.

Two fine offices over the Whiting Mfg. Co., Broadway and 18th St., fronting on Broadway. Elevator, Steam Heat, &c. Location unsurpassed and rent moderate. Very desirable for Jewelers or kindred trades.

## WHITING MFG. CO.,

Broadway and 18th St., New York

## FOR RENT.—CORBIN BUILDING.

Half of an office for \$450 a year. Apply on the premises.

## ROOM No. 37.

## FACTORY AND OFFICE TO RENT FROM MAY 1ST.

Desirable office on first floor with factory on fourth floor. John St., between Broadway and Nassau St. Office, 25x40; factory 25x75. Both connected by elevator and speaking tube. Factory well lighted and ventilated by four high sky-lights. Steam power according to wants. Rent \$2,000, or factory alone \$1,000. Address A. B. care JEWELERS' CIRCULAR.

## TO LET.

One of the most desirable Offices

— IN THE —

## HAYS BUILDING, 21 and 23 MAIDEN LANE.

APPLY AT OFFICE OF THE BUILDING.



**Headquarters**  
FOR  
**ELECTRIC & PORTABLE**  
**Watchman's Clocks**  
Lowest Prices.  
Latest Improvements,  
Patents 1886-1893.  
Send for Circular.  
**E. O. HAUSBURG,**  
41 Maiden Lane, New York. THE "ALERT."

## FOR SALE

IN

## CHICAGO.

An old established Retail Jewelry Business, on a very prominent corner in the business portion of the city. Fine Fixtures and a Clean Stock. A big bargain may be obtained, as owner wishes to retire.

Address C. B. S., care JEWELERS' CIRCULAR.



**The Latest Patents.**

ISSUE OF JANUARY 30, 1894.

- 513,793. BADGE.** JAMES R. LEE, Baltimore, Md.—Filed Aug. 19, 1893. Serial No. 483,519. (No specimens.)
- 513,907. WATCH CASE PENDANT.** EZRA C. FITCH, Newton, Mass.—Filed Aug. 19, 1892. Serial No. 443,469. (No model.)

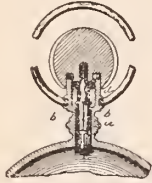

A spring-jawed sleeve for watch case pendants, the same consisting of a metal tube having parallel inner and outer surfaces from end to end, and having one end enlarged or spread to form an outwardly projecting flange, and its other end contracted to form an inwardly projecting flange or lip, the said tube being slotted to form spring jaws having segments of the inwardly projecting flange at their free ends, one of said slots extending the entire length of the sleeve.

- 513,931. JEWEL CHUCK.** JOHN L. HUTCHINSON, La Porte, Ind., assignor to Ezra F. Bowman.

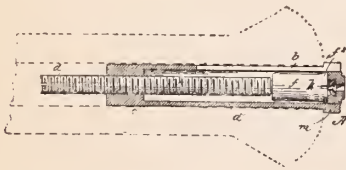

Lancaster, Pa.—Filed Mar. 17, 1893. Serial No. 466,550. (No model.)

- DESIGN 23,019. SOUVENIR SPOON.** ALEXANDER KAISER, Stockton, Cal. Filed Jan. 2, 1894.

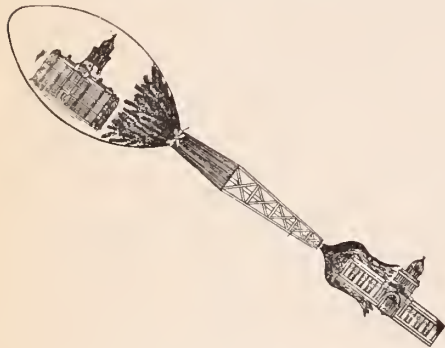

Serial No. 495,453. Term of patent 3½ years.  
*Claim.*—The design for a spoon as herein shown and described.

- DESIGN 23,020. HANDLE FOR SPOONS, ETC.** AUSTIN F. JACKSON, Taunton, Mass., assignor to

the Reed & Barton Corporation, same place. Filed Oct. 18, 1893. Serial No. 488,546. Term of patent 7 years.



- DESIGN 23,021. BADGE.** JOHN M. LEYSON, Butte, Mont. Filed Nov. 14, 1893. Serial No.

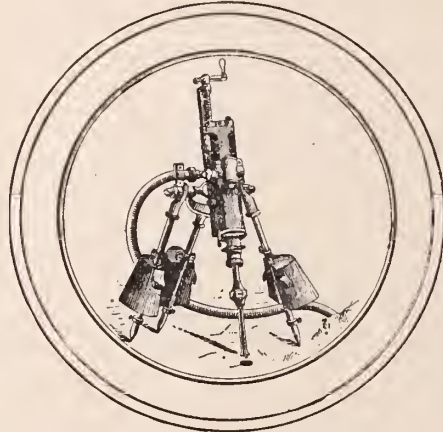

490,961. Term of patent 3½ years.

- DESIGN 23,022. PHOTOGRAPH-MOUNT.** WILLIAM A. KELSEY, Meriden, Conn. Filed Oct 10, 1893. Serial No. 480,777. Term of patent — years.

- DESIGN 23,023. CIGAR-CUTTER CASE.** JOSEPH L. SWEET, Attleboro, Mass., assignor to R. F. Simmons & Co., same place.—Filed May



9, 1893. Serial No. 473,600. Term of patent 3½ years.

- DESIGN 23,026. CLOCK-CASE.** WALLACE C. BROWN, Nantucket, Mass.—Filed Dec. 20, 1893. Serial No. 494,204. Term of patent 14 years.

- TRADEMARK 24,117. WATCHES.** CROSS & BEGUELIN, New York, N. Y.—Filed January 6, 1894.

**CENTENNIAL.**

*Essential feature.*—The word "CENTENNIAL." Used since May 17, 1874.

**Expired Patents.**

EXPIRED JAN. 30, 1894; GRANTED JAN. 30, 1877.

- 186,723. FOUNTAIN-PENS.** P. GOEHRING, Richwood, O.—Filed Dec. 30, 1876.
- 186,838. WATCHES.** J. R. HOPKINS, Washington, D. C., assignor to Wm. B. Fowle, Auburn-dale, Mass.—Filed Jan 12, 1876.

**Several New York Jewelers affected by Fire.**

A fire which broke out at 194 Broadway, New York, last Tuesday evening caused considerable damage to several jewelry firms in the building. The fire is supposed to have started in the factory of Henry Henze, manufacturing jeweler, on the third floor. His loss is about \$2,500. He is insured for \$1,500. A. Wolf, importer of music boxes, on the second floor suffered a loss by fire and water of about \$2,000 covered by insurance. The furniture of W. Naf in the same office was slightly damaged.

The office below this on the first floor is occupied by J. Frank Hill who lost between \$500 and \$600, and the Duryea Jeweler Co. whose loss is about \$300. Both are insured. S. Goldsmith, of the Duryea Jewelry Co., claims that a showcase was deliberately smashed and pens, chains and spoons worth about \$150 taken therefrom. The fire did not reach any of the front offices in the building, one of which is occupied by Rud. C. Hahn, dealer in precious stones.

**The Torrey Bankruptcy Measure as a Substitute of the Bailey Bill.**

WASHINGTON, D. C., Feb. 3.—Congressman Simon P. Wolverton, of Pennsylvania, will on Monday submit a report on behalf of the minority of the committee on the judiciary of the house opposing the passage of the Bailey bill and offering the Torrey bill as a substitute for it.

In view of the criticisms which have been made of Representative Bailey's anti-bond resolution, based on the unofficial statement of the divided Democratic opinion in the house judiciary committee, the members have concluded to give the vote of Democrats on the committee, heretofore withheld.

**Cleveland.**

The stock of Chas. A. Gager has been purchased by E. M. Davis, an old jeweler of Kent, O., who will continue the business at 36 Euclid Ave.

The committee appointed at the last meeting of the retail jewelers to draft a constitution and by-laws for a local jewelers' protective organization, called a meeting for Friday evening, Feb. 2d, at the rooms of the Chamber of Commerce. Twenty-seven retail jewelers were present or sent letters of sympathy with the movement, and desired to be enrolled as members of the organization. The constitution prepared by the committee was adopted. The following officers were elected: A. D. Ernne, president; Philip McCracken, vice-president; William J. Riedel, secretary; Chas. H. Tuttle, treasurer.

**J. R. WOOD & SONS, 14 JOHN STREET, NEW YORK.**



**PLAIN SOLID GOLD RINGS. SEAMLESS PLAIN SOLID GOLD RINGS. ENGRAVED AND CHILD'S RINGS.**  
No Ring Stamped Different from Quality. Send for Catalogue and Price List.

Old Gold and Silver received and estimated on: If amount allowed does not give satisfaction, notify at once and will return at our expense, in same condition as received.

**WOOD & HUGHES. STERLING SILVERWARE MANUFACTURERS**  
New York Agents for the Derby Silver Co.'s FINE QUADRUPLE PLATED WARE.  
NO. 16 JOHN STREET, NEW YORK  
206 Kearney St., San Francisco, Cal.  
HASKELL & MUEGGE, Agents

**ALBERT BERGER & CO**  
47 MAIDEN LANE, N. Y.  
**Spectacles & Optical Goods,**  
GROUND LENSES A SPECIALTY.





**Q**uality the best!!  
Assortment the most complete!!

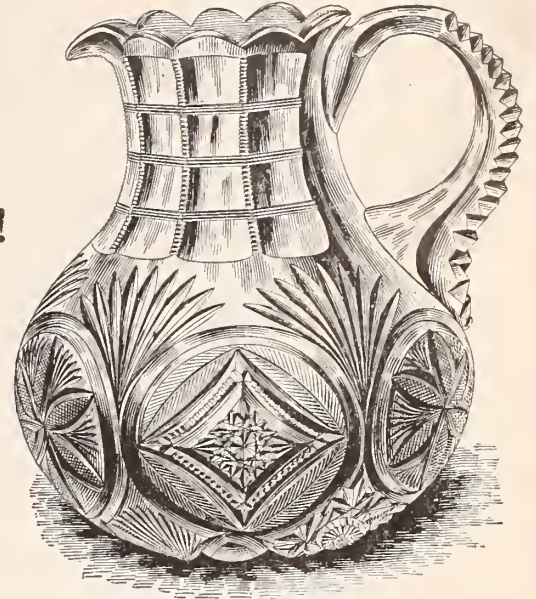

453/58  
PITCHER. 5 Pts.  
"Brazilian."

# RICH CUT GLASS

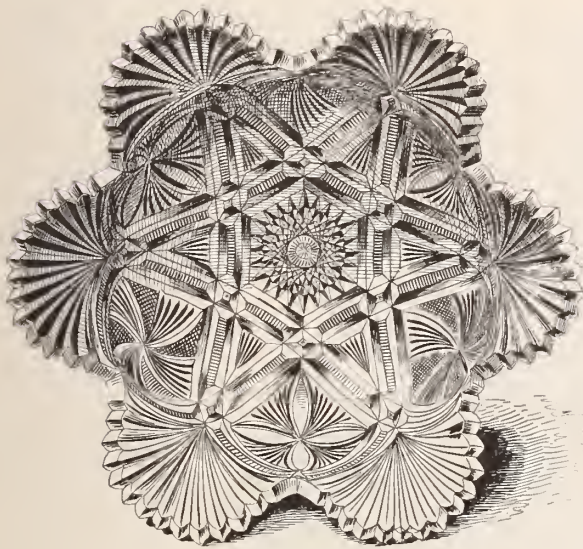

353/56  
SALAD, 10 inch—"San Salvador."

Designs,  
THE MOST ORIGINAL.  
Prices,  
THE MOST MODERATE.

THE "STRAUS" CUT GLASS RECEIVED A MEDAL AND SIX HIGHEST AWARDS FROM THE JUDGES OF THE WORLD'S FAIR. HIGHEST PREMIUM FOR CUT GLASS EXCLUSIVELY, AGAINST ALL COMPETITORS.



TRADE MARK.

# L. STRAUS & SONS,



TRADE MARK.

MANUFACTURERS,

42, 44, 46 & 48 WARREN STREET AND 116 CHAMBERS STREET,

NEW CATALOGUE.

NEW YORK.

NEW CATALOGUE.



# Ferdinand Bing & Co.,

No. 106 Grand Street, New York.

CORNER MERCER.

MARBLE  
BUSTS,  
STATUES  
AND  
GROUPS.



CURIO  
TABLES,  
CABINETS  
and  
Escritaires.

◆ ————— EXTENSIVE LINES FOR 1894 OF ————— ◆

Clocks in Gilt Bronze and Porcelain, China, Boule and Vernis Martin.

..... SPECIAL SHAPES AND PATTERNS.....

NEW DESIGNS AND UNIQUE SHAPES IN LAMPS.

HIGH GRADE POTTERIES AND ARTISTIC GLASS.

LARGE ASSORTMENT OF

— Fine Bronzes. —





## THE HISTORY AND ART OF ROYAL BERLIN PORCELAIN.

**T**HROUGH the courtesy and generosity of Richard Horstman, of Berlin, Germany, who had the management of the Royal Berlin Porcelain Works' fine exhibit at the World's [Columbian Exposition, the Field Columbian Museum of Chicago is the richer by two magnificent vases, one of which is illustrated here. The vases are the personal donation of Mr. Horstman, and are examples of the exquisite art features and skill disclosed by this fine ware.

The vases are about 12 feet high, and are claimed to be the largest pieces of hard porcelain ever made. The body is of royal blue color, decorated with vine leaves in gold and garlands of raised flowers in white and old gold. The medallions displaying cupid heads are in the well-known iron red seen on the Berlin porcelain. Four cupids, almost life-size, form one of the attractive features. Considered from artistic and technical points of view, these vases are fully worthy of the high encomiums they elicited while displayed at the World's Fair.

The Royal Porcelain Factory of Berlin looks back to-day upon a period of 130 years of activity. In 1763, Frederick the Great bought a porcelain factory, the property of a rich Berlin merchant, Gotzkowsky, for the sum of 225,000 thalers. Gotzkowsky, on the eve of bankruptcy, was forced to sell in order to satisfy his creditors with the proceeds. His factory was the reconstruction of one that had been founded by Wegely, a merchant of Berlin, but who in 1757, in consequence of the unsettled state of affairs during the Seven Years' War, was forced to abandon it.

Early in the forties of that century, Wegely obtained from a workman named Ringler, the secret of the production of Chinese porcelain, which had been discovered by Johann Friedrich Boettger, of Dresden, and had been carefully guarded by him.

Ringler had in 1740 stolen the secret from Steidel, the foreman of the Electoral

Saxon Factory at Meissen, who had fled to Vienna, and had disclosed it to a fayence factory at Hoechst, near Frankfort. Reich-

of the latter, but being without sufficient means to carry on the business, had associated himself with Gotzkowsky.

The king, who like many of his crowned contemporaries was exceedingly fond of porcelain, used his personal influence to bring the factory, which he had raised to a Royal institution to new and flourishing development. Grieninger, Gotzkowsky's skilful manager and the whole staff of 146 workmen entered the new Royal institution. In consequence of Frederick's favor and protection, the products of the factory rose considerably both in quantity and quality, and reached a degree of technical and artistic excellence not surpassed by any other make of that period. All the charms and graces of the rococo style, as applied to the shapes of vases, table sets, statuettes, groups and ornaments with their plastic or painted decorations were displayed to the best advantage. At about this time the number of the workmen had reached 400, and there were 10 kilns kept going. After the death of the king, Minister von Heinitz was head of the board of management, which consisted of the directors Grieninger, Klipfel and Rosenstiel. The factory retained its eminence until the beginning of the 19th century, of which a great number of masterly executed pieces and statuettes bear witness. The establishment suffered in many ways during the gloomy years of Prussia's wars and misfortunes. Heavy contributions were exacted by the enemy, and for a long time after the war and the French occupation, the country still felt the stings of distress and poverty. The factory was then forced to deliver up its most costly pieces to the Imperial Court and to French generals. Another circumstance that proved fatal was the Empire style that became the fashion in the beginning of the present century and led to the copying of Greek shapes with straight lines



ROYAL BERLIN VASE DONATED TO THE COLUMBIAN MUSEUM.

ard, a sculptor, who was formerly employed by Wegely, bought the models and material

instead of the gracefully curved and twisted shapes of Louis XV. that seem just to have



## The Connoisseur.

(Continued from page 107.)

been invented for the manufacture of china.

In 1831 Rosenstiel was director of the factory; he was succeeded that year by Frick, after whom came Privy Councilor Kolbe in 1848 and Privy Councilor Moller in 1867. The experiences gained at the Paris Exhibition of 1867, and especially at Vienna, 1873, by a comparison of its own products with those of France, England, Austria and Japan led the Royal Porcelain Factory to make a thorough reform. In 1871 the factory was transferred from the city to the extensive grounds at Charlottenburg, where there was nothing to hinder the enlargement of the buildings in any direction.

Since the death of Director Moller in 1881, an artist has been associated with the director, who is a technical expert. The first artistic director was the sculptor professor, Sussman-Helborn. After his resignation in 1887, the painter professor, Kips, was appointed to the post and got an assistant in sculptor Schley. The management of the institute has been executed by the chemist, Dr. Heinicke since 1886. The institution soon received a fresh impulse under the hands of this newly acquired force. The fine models of the old successful days were soon restored to their well deserved place of honor. While being guided by the spirit of those old forms and decorations, an extensive

series of pieces was created by the foregoing gentlemen, original in shape and decoration which are not in any respect surpassed by the older ones.

An institution for making chemical tests, which was founded in 1878, has proved of great advantage. Quite astonishing results of the greatest importance in the manufacture of porcelain have been obtained through the experiments of Dr. Seger, Dr. Heinicke, Dr. Sarnow, Dr. Pukall and Dr. Hecht. Many new colored and transparent glazes which stand the highest firing have been invented here, also the production of the so-called *craquele* glazes, as well as decorated tiles, that are absolutely weather-proof, making them very serviceable as wall decorations. Painting with enamels on colored glazes, decorations with enamel in relief, and the producing of *pâte-sur-pâte* painting on hard porcelain have all met with the greatest success. The "Seger Porcelain," so-called after its inventor, being a new soft material, which requires a less intense heat for its baking, is capable of receiving a much larger range of colors than other porcelain, including also Chinese red, a shade which for a long time was impossible to produce. Another soft, alabaster-like preparation is especially suitable for bisque figures on account of its warm, transparent hue. The painting on stoneware tiles is also remarkable. Dr. Heinicke has constructed kilns in which single pieces of large dimensions can be fired.

The results of experiments made in the factory's laboratory, as well as the new discoveries and inventions, are not kept secret by the institution, but are freely communicated for the benefit of the whole German ceramic industry.

There are also separate workshops for chasing and finishing the bronze mountings, while large gardens and hot-houses on the premises furnish living models for the study of plants, fruits and flowers.

An enormous quantity of excellent works of the highest artistical and technical execution bear witness to the fact that the porcelain factory has still retained its old prestige and that it is successful in its efforts to be worthy of its great Royal founder.

### COSTLY CULINARY KERAMICS.

WORLD'S FAIR VISITOR (gazing at the \$2,000 pair of vases in a ceramic exhibit)—What are these?

ATTENDANT—Vases.

W. F. V.—And what do you use them for?

ATTENDANT—To boil eggs in, madam!

VISITOR (at Patek, Philippe & Co.'s exhibit)—Where is the watch Columbus wore?

MANAGER STEIN (pointing to a huge astronomical antique)—This one, madam.

VISITOR—What a large watch!

MANAGER STEIN—But you must remember Columbus was a great man.

# A. A. VANTINE & CO.,

877 & 879 Broadway, New York.

200 & 202 Madison St., Chicago.



LARGEST IMPORTERS.

JAPAN, CHINA, INDIA,  
TURKEY, PERSIA.

Fine Porcelains

in useful articles

Bric-a-Brac,

Modern and Antique

Ivories,

Bronzes,

Solid Silver,

Metal Trinkets,



Cloisonnes,

Lamps,

Vases,

Koros,

Screens,

Teakwood

Cabinets.

UNIQUE ARTICLES FROM COUNTRIES OF THE FAR EAST.





ART GOODS AND SPECIALTIES • ———

FOR JEWELERS and ART DEALERS.

WE ARE EXHIBITING THE HIGHEST GRADE OF *ART GOODS* IN *FINE POTTERY, CLOCKS, BRONZES, MARBLE, ONYX, VENETIAN, FRENCH AND DRESDEN FURNITURE, GLASSWARE, CLOISONNE, FAIENCE, BISQUE, ETC., ETC.*, AND BEAUTIFUL COLLECTIONS OF THE MOST CELEBRATED MAKES IN *FIVE PORCELAINS*.

WE HOPE EVERY BUYER WILL RECOGNIZE THE IMPORTANCE OF SEEING THESE REPRESENTATIVE LINES BEFORE PLACING ORDERS, AND MAKE US AN EARLY VISIT.

**GEO. BORGFELDT & CO.,**

18, 20, 22 WASHINGTON PLACE, Cor. Greene St.,

**NEW YORK.**

**The Rambler's Notes.**

WHAT THE RAMBLER SAW AND HEARD AMONG THE DEALERS IN ART POTTERY, CUT GLASS, BRONZES, ETC.



**DRESDEN**

is one of the most attractive of the new lines shown by Ferd. Bing & Co., 106 Grand St., New York.

In lamps particularly, both banquet and boudoir, the colors and combinations of colors are richer than ever before. Excellent examples of this line are the olive, the ivory and Vienna red, and the old ivory and blue mps with raised flowers appropriate to these colors. In the Dresden novelties numerous additions have been made to the cups and saucers, chocolate pots, tea, manicure and desk sets, comb and brush cases, and pin and pen trays.

\*

IMPORT SAMPLES OF POUYAT PORCELAIN.

IMPORT samples of the latest white and decorated porcelain of J. Pouyat, Société La Ceramique, Limoges, France, have been opened by their

New York agent, Alfred Lindsey, 56 Murray St., New York. Cups of all descriptions, sugars and creams, plates and sets are the principal lines shown. Odd designs, entirely new to this ware, and beautiful conceptions in *bleu de four* and other decorations, are in abundance. New and striking shapes are to be seen in all lines of novelties, the number of which is being constantly augmented as the new samples are opened.

\*

NEW GLAZE DECORATIONS IN CH. FIELD HAVILAND WARE.

BEAUTIFUL new decorations in the glaze colors of the Ch. Field Haviland china are to be seen in the warerooms of Haviland & Abbot, the New York agents for this ware, 29 Barclay St., New York. An entirely new shape, the Florence, has been introduced in a full line of table-ware, table novelties, sets, trays, etc. In the Florence, Exhibition and other recent shapes over 175 different glaze decorations are now shown. These range from the richest and most expensive down to the simple but dainty decorations of the cheaper lines. Among the inexpensive patterns shown on plates, cups and saucers, fish, game, ice cream, tête-à-tête and chocolate sets, candlesticks, pin, pen and comb and brush trays, flower-holders and other specialties used by jewelers, are some quaint old English designs, consisting of ivy vines, garlands and

other floral decorations, which are singularly attractive.

THE BEAUTIES OF SAXONIA WARE.

\*

SAXONIA ware is one of the principal specialties controlled by Chas. Ahrenfeldt & Son, 52 Murray St., New York. The import samples of the ware which they are now showing contain various beautiful decorations in the Dresden style, and are the peer of any decoration of this kind ever put upon the market. They consist of large and small flower patterns, festoons with colored borders of green, pink or yellow, similar designs with rich gold ornamentation upon the borders, small flower wreaths, violets, sprays of lily-of-the-valley, large and small flowers with relief gold borders, and lastly but principally, a decoration consisting of floral designs with colored borders similar to some of the patterns previously mentioned, but having in addition exquisite Watteau panels. These Watteau paintings are most perfect in detail, and like the other decorations are shown in a full line of tea pots, sugars and creams, chocolate pots and sets, desk and boudoir novelties, cracker, bonbon, and tea jars, envelope holders, pin, pen and toilet trays, cups and saucers, plates, inkstands and flower holders.

THE RAMBLER.

The engaged young girl thinks a diamond on a finger is worth two or more in a jewelry store.

**CHARLES AHRENFELDT & SON,**

50, 52 & 54 MURRAY STREET,  
NEW YORK.

Take pleasure in inviting all their friends and patrons to inspect their



**Extensive Lines**



**China, Glass and Bric-a-brac**

*Especially Suitable to the Jewelry Trade.*

PARTIES DESIRING TO PLACE IMPORTATION ORDERS WILL FIND SAMPLES OF THE LATEST EUROPEAN PRODUCTIONS NOW ON EXHIBITION.





*Modeller.*

NEARLY A CENTURY OLD.  
 E. GÉRARD, DUFRAISSEIX & CO.,  
 SUCCESSORS.  
 FABRIQUE FONDÉE EN 1797.



[THE  
**CH. FIELD HAVILAND**  
 LIMOGES CHINA

IS MARKED:

WHITE WARE.  
**CFH**  
**GDM**  
 FRANCE

DECORATED.



*Putting handles to cups, etc.*

HAVILAND & ABBOT, { SUCCESSORS TO  
 O. A. GAGER & Co.,  
 CHAS. FIELD HAVILAND & Co.

IMPORTERS OF CHINA,

29 BARCLAY STREET,

AGENTS FOR  
 E. GÉRARD, DUFRAISSEIX & CO.,  
 LIMOGES.

NEW YORK.



*Glazing.*

### "FURNACE FIRE COLORS"

Something absolutely  
**NEW in CERAMICS**

Other manufacturers are unable to use colors fired at furnace heat either under or over the glaze, except in a very limited way, and at a very high price. We now decorate with oxide colors (applying the decoration in an absolutely new manner) and fire them at a heat of 3,000° Fahrenheit right in the same kiln where the white porcelain is baked. This produces a hard beautiful polish, smooth and clear, which cannot be scratched. The decoration is a part of the porcelain and not simply upon the surface.

Just what is needed by Jewelers to meet the exacting demands of their customers.

If interested write for catalogue or information.



*Fire place of kiln during baking.*  
 René Yifa, doyen des entoureurs de Limoges.



No. 1718

# HINRICHS & CO.,

29 AND 31 PARK PLACE, NEW YORK.

## Complete Lines of Import Samples

ESPECIALLY SELECTED FOR THE JEWELRY TRADE.

### BRIC-A-BRAC and ART POTTERY.

Doulton, Worcester, Royal Vienna, Teplitz, Dresden, Sevres, Coalport, Austrian Faience, Bisque Figures and Candelabras.

BOHEMIAN AND FRENCH CHRYSANTHEMUM VASES and Bouquet Holders, Atomizers, Cologne Bottles and Jewel Boxes.



No. 1347.



#### SPECIALTIES IN LIMOGES CHINA.

A. D. Cups and Saucers, Chocolate Cups, Teas and Coffees, Mustache Cups, designs and decorations entirely new and exclusively our own.

OUR SPRING STOCK was never more complete than now, and we never had a finer line of goods. These we will sell at greatly reduced prices for the next three months.

When you come to the city, don't fail to give us a call. Catalogues and Price Lists on application.



No. 1326/15.

## ART GOODS

FOR JEWELERS ONLY, CAN BE SEEN TO BEST ADVANTAGE AND AT LOWEST PRICES AT OUR SHOW ROOMS,

9 & 11 Maiden Lane, Y. N.

LEVY, DREYFUS & CO.



SPECIALTY: SALES OF JEWELRY, BRIC-À-BRAC AND ARTICLES OF VERTU

ESTABLISHED 1870.

**J. L. CLARK,**

SWEEP SMELTER AND REFINER OF GOLD AND SILVER.

Buys every kind of Gold and Silverware, Jewelry, Watches and Platinum. Full market value paid.

No. 724 Filbert Street, Philadelphia, Pa.

SEND BY EXPRESS or Registered Mail. If my price is not satisfactory, I will return all articles.

**HENRY FERA,**  
IMPORTER OF DIAMONDS

AND DIAMOND BORTZ,  
Diamond Cutting and Polishing Establishment,  
10 Maiden Lane, NEW YORK.



# SUGGESTIONS FOR WINDOW AND STORE DECORATION.

Members of the trade who think they have an attractive window are invited to send us a photograph, or a pen and ink or pencil sketch of the same, which will be published if we consider the window contains any originality or lesson.

IDEA LXV.

THE second window of the store front of A. H. Wentz, Westminster, Md., the first of which was illustrated in the last issue of THE CIRCULAR, is depicted herewith, and is really a prettier design than an illustration can bring out. The decoration represents an Esquimaux scene, designed and made for Mr. Wentz's little son's Christmas tree. Mr. Wentz borrowed it to put in his window. This window is of the same size as the other, 66x48 inches. The bottom is covered with salt and sprinkled with powdered mica. The huts are made of plaster of Paris. The Esquimaux are small dolls covered with fur and sit on sleds drawn by dogs and deer.

WINDOW DRESSING NOTES.

Scarf pins and other jewelry combining live lizards, usually designated as chameleons, form a very attractive feature in window displays.

John Hood, Santa Rosa, Cal., last Thanksgiving had a unique and attractive window decoration. The arrangement represented a miniature reproduction of the first church

in New England. It was made by covering a wooden box with small pine twigs, and cutting holes in it for the doors and windows.



AN ESQUIMAUX SCENE AS A WINDOW DRESSING.

Small pine trees, old logs and stumps surrounded the building, and a path led up the hill to the door of the church. Watches,

jewelry and small pieces of silver were placed to good advantage on the earth surrounding the church.

The success which Mathey Bros., Mathez & Co., 21 Maiden Lane, New York, have obtained with their complicated watches induced them to increase in variety their already large stock. They invite all jewelers to call and make selections for the Spring racing season. The 10 size split seconds,

which they manufacture, is a very desirable watch, being much smaller and thinner than those that have been made heretofore.

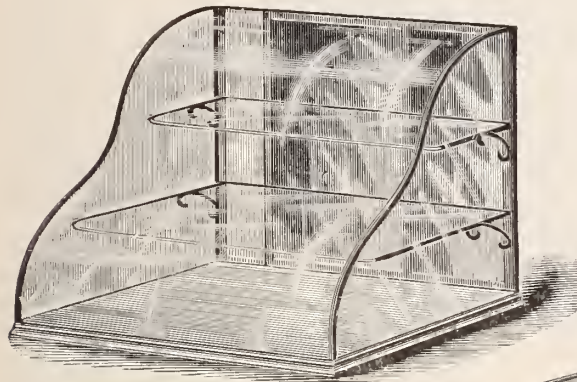

**B. & W. B. SMITH,**

220 W. 29th Street,

NEW YORK.

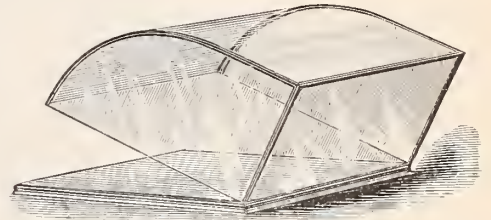

SMALL CASES.—ALL SIZES.

For Display of Specialties.

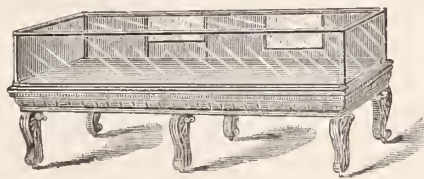
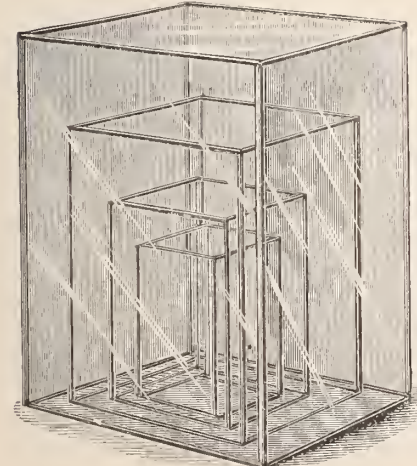

Improved Dust Tight Counter Cases.

IMPROVED WALL CASES.

NOVELTIES IN CASE WORK.

CASES ALL GLASS. NO BAR OR MOULDING.

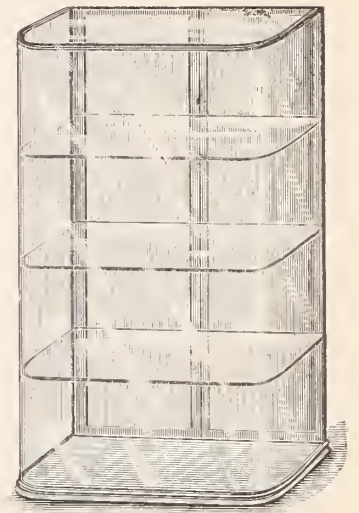

CALL AT OUR SHOW ROOMS AND EXAMINE.



## THE MYSTERY OF THE PEARL NECKLACE.

*Abi S. Jackson.*



HERE is your wedding present from me, Agnes," and my Uncle Gerald laid in my lap a small rosewood box, thickly covered with a delicate frost-like fretwork of silver. "Look at it and then tell

me if you are pleased with my gift." I pressed the spring and as the lid flew open,

I could not suppress the cry of admiration that arose to my lips, for there upon a bed of azure velvet, lay the most exquisite pearl necklace that I ever beheld, great, luminous beauties that seemed fairly to quiver and throb with life. Never before had I seen such pearls.

"Where did you get them, Uncle Gerald?" I asked him, hugging my treasures to my breast, for I almost feared the lovely things would vanish into air. "Where in all the world did you find them?"

For some moments he did not answer, but stood leaning his elbow on the mantel, gazing down into the ruddy coals that burned cheerily within the grate, and I noticed his face had grown strangely pale. Presently he turned to me again.

"Agnes," he said, very gently. "Those pearls were purchased for a wedding present long before you were born, child. For twenty years they have been hidden away from the light of day, while she for whose fair throat they were intended, sleeps in the old churchyard. You have often wondered why I never married; now, I will tell you, for you are to be a bride yourself in six weeks, and you will understand how I have grieved in silence for twenty long years."

The flickering firelight threw warm, rosy shadows over his handsome face and silvered

hair. Secretly I had always considered my Uncle Gerald a king among men, and since the day fifteen years ago when he had brought me, a lonely little soul of three, orphaned in one short week, home with him, he had never spoken an unkind or impatient word to me. And Oakwood, the old Virginia homestead, was in reality the only one I ever knew. I had just graduated from boarding school, and in six weeks time would become the wife of Arthur Carston, the young owner of Carston Hall,

on as though suddenly aroused from a dream. "The wedding night was set for Christmas Eve, too. You remember, Agnes, that I tried to persuade you into changing the date for your wedding, but I never gave you my reasons for so doing. It was because my own happiness was wrecked upon that night, and I feared yours might be blasted, too. It was only a superstition, I know, and yet when one has known the

greatest sorrow of one's life upon a certain day, ever after he is bound to fear that day. But to go on with my story, sad and brief enough. I purchased this pearl necklace for my bride, intending to surprise her by hanging it about her neck when she was dressed in her bridal robes on her nuptial night; but alas! unkind fate willed it otherwise, for a few hours before she was to have become my wife, they found her dead in her bridal dress and veil. I could not bear to look at the pearls again, and since that night they have been locked in that oaken cabinet in the room you now occupy—the room prepared

for the bride destined never to enter it. You understand, at last, the reason why I have never married, Agnes."

"I understand quite well, Uncle Gerald," I answered in a low whisper, a feeling of

awe and reverence creeping over me, "and I shall treasure the pearls more than ever, for they seem like a legacy from the holy dead."

"If you will follow me I will show you her picture," he said, a trifle unsteady, and he led the way through the long hall with its shining waxed floor, dotted here and there with huge fur rugs, up the broad stairway, along the echoing picture gallery, and into a small room at the end, the door of which was always locked. We entered, and by the light of the taper he held in his hand, I saw before me the loveliest face that I had ever looked upon, the face of a young girl framed in a cloud of floating golden hair.



THE FACE OF A YOUNG GIRL FRAMED IN A CLOUD OF FLOATING GOLDEN HAIR.

the plantation adjoining Oakwood. It was arranged that my wedding day should fall on Christmas Eve, and the house was in a delightful state of preparation from early morn until late at night.

Outside among the leafless trees I could hear the November wind sighing dismally and the rain beat drearily against the window panes, while in the stables the watchdogs tugged at their chains, baying loudly. Unconsciously I shuddered and drew nearer the fire, thankful that I did not have to be abroad that wild, wet autumn night.

"It is twenty years ago this very month, that I was looking forward to my marriage with a beautiful girl," Uncle Gerald went



Her ripe, red lips were parted in a heavenly smile, and the calm fair brow seemed fitted only for a halo from above. Her robes of purest white could not conceal the perfect curves of her maiden form, and in one dimpled hand she clasped a cluster of half opened rose buds, no fairer than the dainty fingers encircling their slender stems. No wonder that Uncle Gerald had been faithful to the memory of such a dainty creature for twenty years, and as he turned away from the beautiful pictured face, I saw the glint of a tear in his eyes.

Long I sat by the fire, in my own room that night, dreaming of the young girl who had died upon her wedding night, and more than once I dashed from my eyes a blinding mist, for it was such a pitiful, sorrowful tale. The pearls I had locked securely in the oaken cabinet, and I must have fallen into a doze, for I started up in my chair as one will when aroused from slumber suddenly. The clock out in the hall was striking the midnight hour; the fire had burned itself low, and only a few dull coals glimmered through the grey ashes. The atmosphere was bitterly cold and a strange silence hovered over all. Shivering, my heart throbbing with fear, at what, I knew not, I leaned back against the cushions, my eyes fastened upon the cabinet at the other side of the chamber. It was plainly discernible, for the rain had ceased, and a full moon poured her pallid light across the floor.

Was I dreaming, or were my fascinated eyes playing me a trick, I asked myself? For a faint, almost imperceptible shadow seemed to have settled down over the sturdy oaken cabinet, gradually growing stronger and plainer each second, until it took on the semblance of a human form. Then I saw the gleam of golden hair; the sheen of white satin, the mist of a floating bridal veil, even the coronet of orange blossoms crowning the graceful head were there. *It was the beautiful girl who had been dead for twenty years—the girl whose picture I had seen only a few hours before!*

Presently she came nearer, and I inhaled the fragrance of the orange blossoms, but with their sweetness mingled the damp, musty odor of the grave, and I shrank back shuddering. A sorrowful smile flitted across the exquisite face, a sigh heaved the snowy bosom.

"Fear not," she murmured in low, wavering accents, like the echo of æolian harp strings; "I come not to harm one so young and fair. But it is lonely out there, and for twenty years have I slept in that quiet city of those silent ones, twenty years."

Her voice was so gentle, so filled with sadness, that my fear gave place to sympathy, and boldly I asked:

"Who are you that you enter my chamber in this strange fashion and in bridal attire?"

Again that tremulous voice replied:

"I am one who knows you well; one

who fain would see you happy in the light of that which was denied her—wedded love. Listen. In six weeks you will be a wife. You will know the bliss that the pure and good in heart are sometimes forbidden to know. You will go to the arms of one who loves you, I will go back to my grave, there to rest quietly until my restless spirit shall

me so happy, so happy. I shall not forget you when I return to that Silent Land. A long and happy life awaits you; it is all sunshine and roses. There are no storms, no sharp and cruel thorns to pierce your tender feet, and I am glād. I will go now, but to-morrow night at this same hour I will return. Take the pearls from the oaken

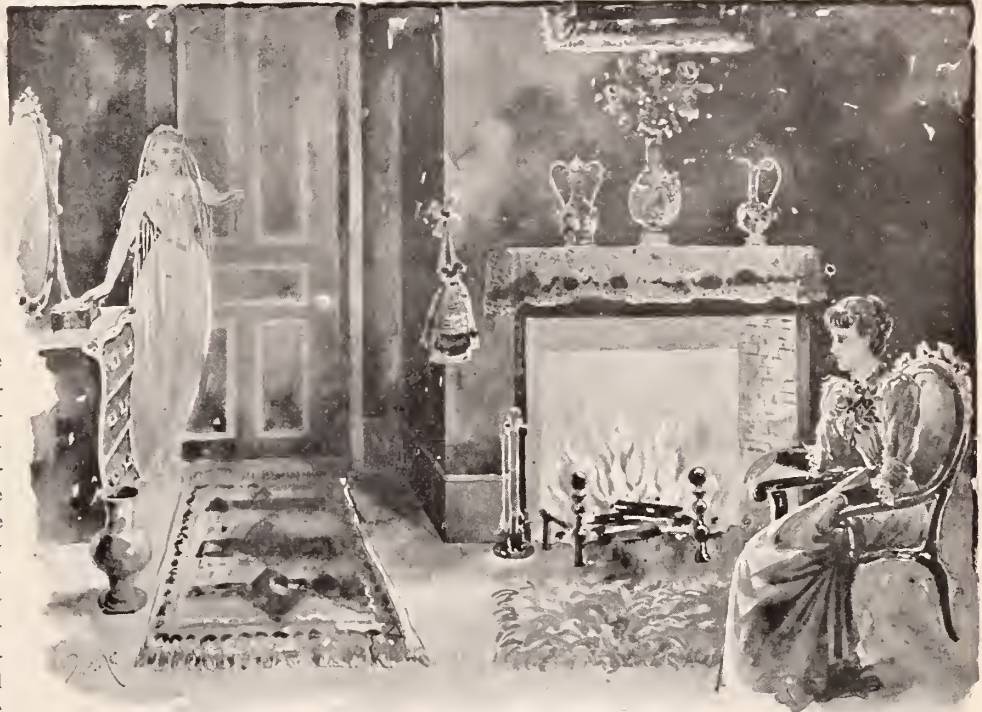

AN ALMOST IMPERCEPTIBLE SHADOW SETTLED DOWN ON THE OAKEN CABINET.

be allowed to roam in freedom once again. But before I go I have a favor to ask of you. Will you grant it?"

"Ask what you will, and it shall be granted," I answered, losing all fear, curiosity taking its place. She came close to me, and I fancied that I saw a tear roll slowly down her lily-white cheek. How fair, how life-like were the gentle eyes, the sorrowful wavering smile. It seemed cruel to think that so much loveliness must be hidden within the dark and gloomy portals of the grave.

"He has given you my necklace, the pearls that were to have been worn by the happy bride twenty years ago," the sweet tremulous voice went on. "You are to wear them on your bridal night. They will belong to you ever after. Let me have them for a little while. I have been denied the dainty things all these long, long years, and they will make me so happy. It is cold and lonely out there, ah, so lonely. Surely you will not refuse me? It is only for a short time that I wish them, then you shall have them again. You have so much; I have so little. May I have them?"

"Yes," I answered in a whisper, wondering if I should awaken, and find it all a dream. "You may have them."

A gentle sob filled the room.

"How good you are," she murmured. "How good you are! And you have made

cabinet, unlock the casket, and lay it upon yonder table. Farewell, dear child, farewell."

She waved her transparent hand and glided toward the window, where she paused for an instant. Then an icy wind, that froze the blood in one's veins, swept through the air and the next moment she was gone, vanished as completely as though the earth had opened and swallowed her.

I rubbed my eyes and pinched my own arms in order to satisfy myself that I had not been dreaming, and, strange to relate, I was not at all frightened. At any other time I should have swooned with terror, but now I felt an overwhelming curiosity—a longing and desire to know more of my ghostly guest. I found myself actually wishing for the hour when she would visit me again.

The sullen, raw November dawn was creeping in at the window when I sought my couch. But I could not sleep. Vainly I tossed from side to side, striving to coax the little god of slumber to visit my eyes, but for once he evaded me. No matter in what direction my gaze wandered, there I saw before me that white-robed figure, that exquisite face with its crown of golden curls wreathed with orange blossoms. The wailing wind outside melted into the music of her voice, sweeter than the chimes of silver bells. And at last, in despair, I arose



and sat by the window through which she had vanished, wondering at the mystery of life and death.

I had been taught to believe that with death came perfect happiness. At school the old, old story had been impressed upon my mind—the belief that existence here was but a feverish dream, ending in the long, last sleep that set the soul free to seek eternal happiness in the realms beyond the dark depths of space. But like all young girls of my age, I shrank from the mere thought of the grave, and now my belief was shattered, for surely *she* was not happy there, else why did she return to earth after twenty years? The more I dwelt upon the thought the more I wished to forget.

I wondered what that beautiful girl's feelings were, when upon her bridal night twenty years ago, her pure and gentle spirit, freed from its fleshly fetters, paused for a moment to look at the cast off form and face, ere it soared away into the Great Unknown. It could not be that she was happy, for only a few moments before her soul was thrilling in raptures, filled to overflowing with human love and earthly happiness. And to be snatched suddenly from the warmth of the arms she loved; to be torn from the very altar, and sent out to seek for the path that led to the Silent Land, timid and alone in the midnight blackness that lies between the worlds, ah, who can call *that* happiness?

With a shiver I drew away from the cold and cheerless scene without, and hastily dressing, went down to the cosy breakfast room where a crackling fire soon drove away all morbid thoughts and fancies. And as I sat sipping my coffee, the events of last night seemed more like a dream than ever.

All day long I wandered from room to room, restless, nervous, feverish, dreading yet longing for the night to come. The hours dragged like weeks; never did the hands of the clock move quite so slowly, and I could not content myself in one place for half an hour.

At last I was alone in my room once more. It was only nine o'clock as yet, but I could not remain down stairs another moment. There was a fascination in that old oaken cabinet that I could not resist, and I found myself gazing at it as though its awkward and ungainly proportions were the most slightly object in the world. I heard the clock strike ten, then eleven, and I held my breath as the seconds flew by, for in less than an hour she would be here.

With trembling hands I drew forth the dainty rosewood casket, and unlocking it,

lifted from its azure bed, the gleaming necklace. How the great, luminous pearls shone there in the darkness like pallid miniature moons. And as I caressed them they seemed to cling to my fingers as though loathe to leave my hands. Reverently I laid them back upon the velvet cushion, and resumed my seat before the fire.

*Twelve o'clock!* I leaned forward, straining my eyes through the darkness, the loud throbbing of my heart the only sound to disturb the death-like stillness. Again I felt that icy wind chill my blood; again I saw that shadowy presence hover about the oaken cabinet, and then that slender form, clad in the snowy bridal robes, stood before me. Again I heard that tremulous, eager voice, sweet and low, yet so full of sorrow and longing.

"You have kept your promise, dear child," she murmured, a smile trembling upon her lips. "You are so good, so true, and I shall never forget you. I will take the pearls with me to-night, and on your wedding night you will find them back in their casket, safe within the oaken cabinet. But I cannot return with them. I would like to come to you when you stand in your bridal robes, but, alas! I have not the power to do as I would in all things. You do not fear to let me have them until then, do you?"

"No," I answered slowly, like one in a dream, "I do not fear to let you have them."

"They will make me so happy," she sighed, and I saw the bright tears hang like diamond fringes to her long, curved lashes. "Only for a few short weeks shall I have the pleasure of having the beautiful gems for my own, and then you will have them ever after. But I am not envious nor angry. I would rather see them about your fair neck than on any other woman, because I know *he* would, too. I must go now, child. Would that I might be allowed to visit you once more; but, alas! it is not so to be! On your wedding night, when you are dressed in your bridal robes, go to the oaken cabinet and there you will find your treasures. Think of me now and then, dear child, and farewell."

Again that icy wind froze the very marrow in my bones, and the next instant I was alone. Only for a moment did I sit in the arm chair, but with a startled cry I sprang toward the table where the shadowy figure had been standing. The pretty rosewood casket was still there, but *the pearl necklace was gone!*

My brain whirled, my heart seemed to stop beating, and I rubbed my eyes vigor-

ously in order to convince myself that it was real, and not a dream. I passed my hands over the velvet lining, but no, it was true. My precious pearls had vanished.

Closing the empty casket, I locked it and put it away in the oaken cabinet, locking that in turn, and hanging the key on a blue ribbon about my neck. Then I went to bed and slept soundly until morning, resolving not to say a word to anyone about my mysterious guest.

The days rolled swiftly by, and at last my wedding day dawned. During all those weeks I had not once been near the oaken cabinet. Several times I had made the attempt, but an unseen hand seemed to hold me back; a tiny voice whispered: Wait. Not a word had I uttered to my betrothed nor my uncle, for I well knew that they would only laugh and say it was a mere fancy, a vision of an imaginative brain. Just before I went to my room to begin dressing, Uncle Gerald came to me, and taking my face between his two palms, said gently:

"You will wear the pearls this eve, Agnes, which fate would not allow *her* to wear twenty years ago to-night. God grant that they may give unto you the happiness which was denied me."

I turned away choking back a sob. Poor Uncle Gerald; so good, so noble, and yet how sorrowful and lonely was his life.

Alone in my room at last. I had dismissed my maid and for one moment I stood gazing earnestly at the face and form the mirror so faithfully portrayed. I was not displeased with them, but never could I hope to look one half so fair in my bridal dress and veil as the young girl who died twenty years ago looked in her's.

Scarce did I breathe as I walked across the floor, pausing before the oaken cabinet. My hands trembled so that I could hardly unlock it, and as I drew forth the silver bound casket, and pressed the spring, I closed my eyes, fearing to look. Slowly, half fearfully, I put forth one hand, and touched something round and cold. I opened my eyes quickly. *The pearls were there.*

It was some time before I was sufficiently composed to go to the mirror again. As I clasped the mystic, gleaming necklace about my neck, I fancied that I heard a hollow wail of despair close beside me, but only the bright emptiness of the room met my startled and searching gaze.

This all happened five years ago, and for the first time in all those years, dear reader, I give to you the story of the mysterious pearl necklace.









# Rich Cut Glass

AND

DECORATED ART WARES.



Mt. Washington Glass Co.,

New Bedford, Mass.

RICH DISPLAY OF GOODS AT

New York Store: 46 Murray St.

When you visit Chicago do not fail to inspect our full line of goods at the new store of Pairpoint Mfg. Co., 224 Wabash Avenue.

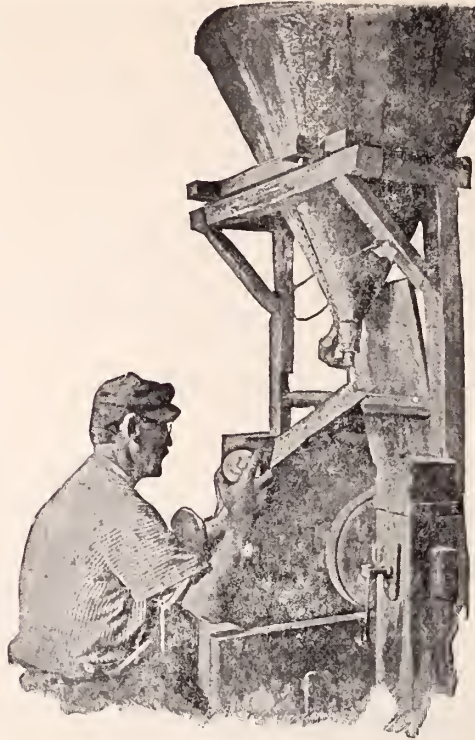

GLASS CUTTER AT WORK.

... THE ...

# American Horological Institute

AND TECHNICAL SCHOOL OF LANCASTER, PA.,  
LATE OF PHILADELPHIA, PA.,

A Trade School where Watchmaking is taught practically. We do not manufacture

☼ BICYCLES OR DYNAMOS ☼

at this institute. We confine our work strictly to WATCH WORK and its kindred branches, which include

≡ Engraving, Jewelry Work and Optics ≡

One tuition pays for all the branches. We do not have boy instructors at this institute, all men of years of experience. Each department has its separate instructor. Our institute is open for inspection. We kindly invite you to visit us and inspect our school modes of giving instruction and the progress that our students make by giving them practical instruction.

**THOMAS PENDERGAST,**  
PROPRIETOR AND MANAGER.

**Paul Jeanne,** EIGHTEENTH STREET and 4<sup>TH</sup> AVE., N. Y.  
(Bradley Building.)

MANUFACTURER OF

≡ FINE ⊗ DIAMOND ⊗ JEWELRY. ≡

**JOHN N. DISSELKOEN,**  
Cutter and Importer of  
**DIAMONDS**

FACTORY,  
76 LANGEBLEEKSPAD  
AMSTERDAM.

19 East 16th St.,  
NEW YORK.

JACOB-FONTEINS  
A SPECIALTY.

All Goods direct from  
My Holland Factory

# Waltham Horological School,

PALMER & SWAIN, Props.,

WALTHAM, MASS.

## Summary of Prospectus.

**LOCATION** in Martyn Square, in the city of Waltham, Mass. Pleasant location, hotels, boarding houses, churches, etc.

**CURRICULUM**:—Pupils are taught watch making, repairing and bench tool making complete. American and foreign systems. Special branches taught when desired.

**BRANCHES TAUGHT** include work on plates, barrels, wheels, pinions, jewels, balances, staffs, springs, screws, stem-winding parts matching, gilding, finishing, adjusting, repairing, tool work, engraving, etc., etc. Also a thorough course in Ophthalmology by a professor of universal reputation and a course in gem cutting if desired.

**COURSE** may begin at any time and pupils are taught to make everything that enters into a watch movement. When the student has finished his course he is able to make and put together a watch complete in all its parts and properly adjusted; he is also a first-class repairer and gets such a thorough instruction in his trade as cannot be obtained in any workshop or any other school in the United States.

**A NEW FEATURE** for those who may not desire the full course, is an advanced course of tuition suitable for those already grounded who desire instruction in the higher branches, or in other words, a finishing course. This will be undoubtedly appreciated by many watchmakers who feel hardly competent to repair complicated watches.

The workshop of this School is fitted up with thousands of dollars' worth of the best watch tools and machinery, and with the capable instructors always ready to give their attention to the individual student, there being no class system, he has an advantage not to be obtained elsewhere. Materials for a watch movement will be given free to students who desire to make a watch of their own.

Send for new prospectus and terms for special branches, etc.

D. D. PALMER.

EUGENE H. SWAIN.



61 Hanover Street, Boston, Mass.

Sales made for Jewelers only in their established places of business. Can give best references of any auctioneers in America.

All communications strictly confidential.



**FANCY DIALS**  
 TO FIT AMERICAN WATCHES.  
**\$6.00 per dozen.**  
 IN FLAT SECONDS.  
**\$7.20 per dozen.**  
 IN PRESSED SECONDS.

Jobbers, Importers and Retailers generally, will be re-  
 mitted by sending to us any Dials of our make which they  
 may have on hand.

**O'HARA WALTHAM DIAL CO.,**  
 WALTHAM, MASS.

**CROUCH & FITZGERALD.**

Jewelry Trunks  
 and Cases,  
 161

Broadway,  
 Bet. Cortlandt and  
 Liberty Sts.,  
 688 B'way,  
 701 6th Ave.  
 NEW YORK.



**OFFICES TO LET**

IN THE

**HAVEMEYER \* BUILDING.**

GOOD LIGHT AND SERVICE, ALL IM-  
 PROVEMENTS, FROM \$450 UP.

For particulars apply to

**W. B. DUNCAN,**

Office, 815 Havemeyer Building, N. Y.



Elk, Shrine and Masonic  
 Emblems a Specialty.

Badges of Every Known Order.

G. A. SCHLECHTER,

Manufacturing Jeweler.

READING, PA.

**DIAMOND EXCHANGE BUILDING.**

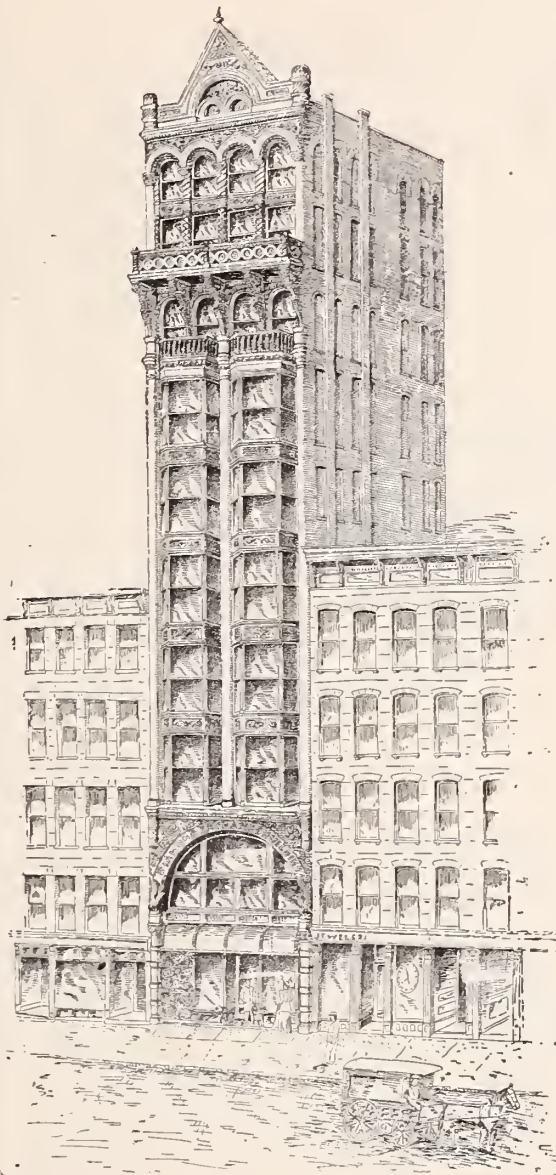

In the new fire proof,  
 ten story

Diamond Exchange Building,

14 Maiden Lane.

**OFFICES**

of most modern construction  
 with abundance of light and  
 air, rapid elevator, mail chute,  
 steam heat, gas and electric  
 light, exposed sanitary plumb-  
 ing, oak cabinet trim, unique  
 plate glass partition and quar-  
 tered oak floors. at rentals from

**\$900.00**

Per Annum up.

Specially adapted for the Dia-  
 mond and Jewelry Trade.  
 Possession on or before May  
 1st, next.

For further particulars apply to

**E. A. Cruikshank & Co.,**

176 Broadway, N. Y.

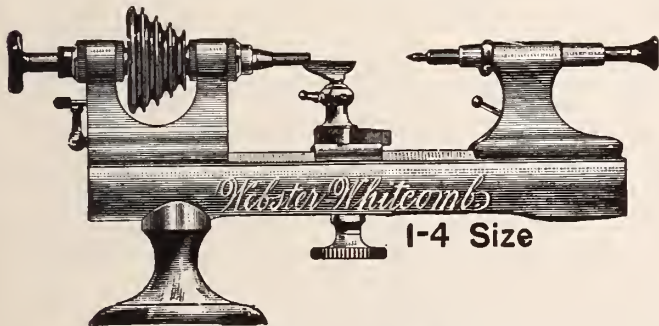

STRONGEST GUARANTEES.

**Quality Maintained.**  
**Prices to Suit the Times.**



ASK FOR OUR NEW PRICES AND

TERMS FOR 1894.

**AMERICAN WATCH TOOL COMPANY**

Chymistry Dist., Waltham, Mass., Stoney Batter Works.





**Boston.**

Alvin T. Morrill, of the Morrill Bros. Co., is convalescent.

E. A. Cowan starts this week on his Spring trip to the gulf and Pacific coasts.

M. Myers has opened a place on Harrison Ave., for the making and bottling of his "Hub" preparations.

The E. Howard Watch & Clock Co. have declared their semi-annual dividend, the amount being \$2 per share.

D. B. Spear, of Henry T. Spear & Son, who has been in poor health for several years, is seriously ill with an attack of the grip.

Frank Story, son of jeweler W. H. Story, Hillsboro Bridge, N. H., is taking a course in Palmer & Swain's Horological School at Waltham.

Morrill Bros. Co. closed Saturday last at 2 P. M., and for the following ten hours the whole force was as busy as a hive of bees at stocktaking.

Buyers here last week included George Bemis, Charlemont; M. L. Hildreth, Marlboro; Mr. Lunt, of Safford & Lunt, and W. P. Jones, Newburyport.

The regular annual meeting of the Boston Jewelers' Club will be held at the Boston Tavern, Feb. 13th, at which time plans will be made for the annual ladies' night of the club.

Charles W. Beals, the Milk St. jeweler, slipped on an icy pavement Thursday morning and fell, breaking a leg. He was taken to the Emergency Hospital for treatment, and later conveyed to his home in Newton.

The committee of inquiry appointed at the meeting of E. H. Saxton & Co.'s creditors, has reported, recommending that the concern pay 40 cents on the dollar, 33½ cents cash, and the balance in notes to run six months. It is expected that the creditors will accept this method of settlement.

A. Stowell & Co. have opened an art gallery in connection with their jewelry store. The room fitted up for this purpose is very pretty and the ceiling is covered with palm-leaf fans in a way that gives it a very attractive as well as unique effect. The gallery is filled with a good collection of pictures, mostly by foreign artists.

The E. Howard Watch & Clock Co. are placing a striking clock, with four 7-ft. illuminated dials, in the new county court house at Mauch Chunk, Pa.; also a 5-ft. dial, illuminated tower clock at the headquarters of the electric railway company in

Rutherford, N. J., and a striking clock, with four 6½-ft. dials, on the town hall at Alton, N. H.

**Baltimore.**

S. S. Yingling, for a number of years in the adjusting department of Elgin National Watch Co., is preparing to open a handsome new jewelry store in Reisterstown, Md.

After a retirement of five years Max Kohner has returned to the jewelry business as the successor of M. Daniel, deceased. Mr. Kohner is carrying on a jobbing trade exclusively and will push his business through the south. Wm. Groedel is traveling salesman for the house.

John Gannon was before Justice Sanner Monday last, on three charges of obtaining goods under false pretenses. It was alleged that he represented himself to be a watch and clockmaker, and obtained clocks and watches from various persons. He was committed for a further hearing.

Jobe Mills, aged 78 years, died on Jan. 28, at his home, 1325 N. Broadway, after a short illness. Mr. Mills was a jeweler and for thirty-six years carried on the business at the corner of Pratt St. and Cheapside. In former years he was a member of the Friendship Fire Company and a first lieutenant in the Baltimore National Blues. He leaves a widow, three sons and two daughters.

**Lancaster, Pa.**

Ezra F. Bowman has been confined to his house for a week with rheumatic trouble.

Through a fund started by Simon Muhr, Philadelphia, the liens on the home of Frank George, of this county, who lost the sight of both eyes by an accident recently, have been entirely satisfied.

Among the traveling men in Lancaster the past week were: Mr. Weil, J. M. Weil & Bros.; E. S. Shepherd, R. F. Simmons & Co.; Chas. F. Duffy, Enos Richardson & Co.; W. Strauss, Jacob Strauss & Sons; Alva J. Lasher, Whiting Mfg. Co.; F. Van

Olinda, Wm. L. Gilbert Clock Co.; Mr. Halstead, Barbour Silver Co.; H. Aliyn Parker, Bassett Jewelry Co.; representatives of Towle Mfg. Co. and Skillman, Vandever & Williams.

**AIKIN, LAMBERT & CO.**

19 Maiden Lane, NEW YORK.

Branch, 42 & 44 East Madison St., CHICAGO, ILL.

Manufacturers and Exporters of

Gold Pens, Holders, Picks, Pencils,

Fountain Pens, etc.

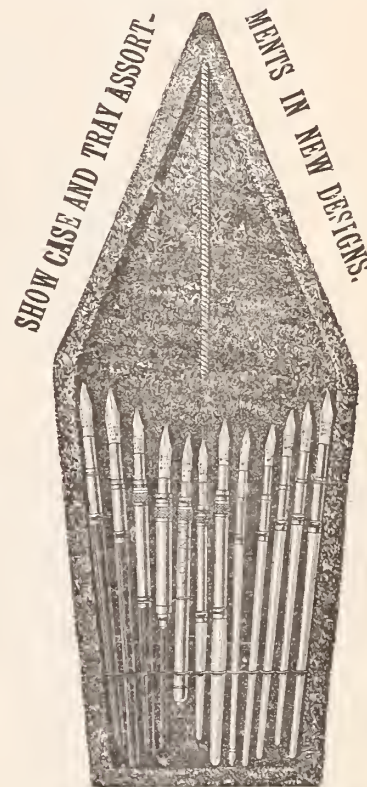

11 x 5½ inches.

PLUSH TRAY WITH EASEL BACK.

1 Doz. 16 K. Pens and Assorted Holders, List, \$30

1 Doz. 10 K. Pens and Assorted Holders, List, \$24

Send for Trade Discount.

**Jules Jürgensen**

OF COPENHAGEN.

The reputation these watches have maintained for Fifty Years has never been equalled, being made on strictly scientific principles and no expense spared to give the Best results in mechanism and timekeeping qualities.

SOLE AGENTS,

John C. Hyde's Sons,  
NO. 22 MAIDEN LANE.

**WIGGERS & FROELICK,**

60 NASSAU ST., NEW YORK.

Sample Cases and Trays

For Watches, Jewelry, Optical Goods, Etc.

WE STRIVE TO MAKE THE BEST.

**JOHN N. DISSELKOEN,**

Cutter and Importer of

**DIAMONDS**

FACTORY.  
75 LANGBLEEKERSPAD,  
AMSTERDAM.

19 East 16th St.,  
NEW YORK.

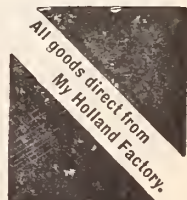

### Trade Gossip.

Have you seen the watches shown by D. F. Conover & Co., Philadelphia, Pa., on another page?

For some artistic sterling hollow ware see the announcement of the P. L. Krider Co., Philadelphia, Pa.

Foster & Bailey's pyramid furnishes some good reading matter. Look it over carefully. It will repay you.

The Adelphi Silver Plate Co., 62 John St., New York, quote some prices in their advertisement which will be of interest to dealers.

F. M. Whiting & Co., North Attleboro Mass., show four beautiful patterns on another page of this issue. Have you looked at them?

Léon Favre, 107 E. 26th St., New York, whose miniature work on watch cases has won for him an enviable reputation in this country, is at the present time busily at work on miniature portraits on ivory which are in special demand.

The new rococco border offered by Thos. W. Lind, 67 Friendship St., Providence, R. I., will be highly appreciated by the trade. The small ballet dancer shown in his announcement may be had in half a dozen

different postures, and is only one of the many figures and ornaments offered by Mr. Lind.

The assortment of dial washers offered on another page is something which will be appreciated by every watchmaker. These "Best Made" washers are each hand burished, silvered on one side and properly curved. The goods have been on the market for years, in single boxes, and have given universal satisfaction. They can be ordered from any first-class jobber or material dealer.

The withdrawal of S. S. Battin, Jr., and J. D. Battin from Leroy W. Fairchild & Co., already announced in these columns, brings into the field as manufacturers of silver, gold and jeweled novelties, the firm of Battin & Co., Third Ave. and Ogden St., Newark, N. J. This house have taken up the novelty business of the old firm of Leroy W. Fairchild & Co., and as is evidenced by their full-page announcement in this issue, they offer a most complete and attractive line.

The great popularity and high reputation attained by American silver plated ware not only in this but in other countries is perhaps in a large measure due to the artistic and tastefully lined boxes in which the best houses now put up their wares. Apropos of this fact the Rogers & Hamilton Co., Waterbury, Conn., remind the trade that they were the first in the field to put up their goods in fancy lined boxes. That the feature was appreciated is evidenced by the rivalry to-day of the various makers of silver plated ware who try to outvie each other in supplying handsome boxes for sets and single pieces.

Among the novelties made by the S. Cottle Co., Jackson building, Union Square New York, perhaps the most artistic are in the line of Dresden desk and toilet goods mounted in sterling silver. One of these pieces is illustrated on the page bearing the firm's announcement. These goods have been highly commended wherever shown, and have been purchased by some of the shrewdest buyers in the country, who had the satisfaction of seeing them sell rapidly. These goods are made only by the S. Cottle Co. and when first introduced just before the holidays, rapidly proved themselves the best and most artistic novelty of the season.

S. F. Myers & Co., since they have completed the re-modeling of their buildings, at 48 and 50 Maiden Lane, New York, have one of the most complete and commodious establishments for the transaction of business to be found in the country. Since the requirements of their heavy business demanded an immediate enlargement, the firm determined to do it in "ship shape," with the result that every modern improvement has been utilized, electricity playing an important part. Not to the least interesting feature noted in a visit this busy house is the quiet and thorough system that prevails. Visitors to the metropolis who desire to inspect a model establishment, and incidentally make a few purchases.

## DIAMONDS.

### Wm. S. Hedges & Co., Importers of Diamonds,

And Manufacturers of DIAMOND JEWELRY.

170 Broadway, New York.

22 Holborn Viaduct, London.

### Alfred H. Smith & Co.,

IMPORTERS

## DIAMONDS

AND

PRECIOUS STONES,

182 BROADWAY, COR. JOHN STREET.

NEW YORK.

33 Holborn Viaduct, London, E. C.

To insure Publication of Advertisement in current week, copy should be received not later than Monday Night.

## OLDEST PUBLICATION

Of all the Jewelry Journals.

Jewelers' Circular Publishing Co.,

189 BROADWAY, NEW YORK.

ESTABLISHED 25 YEARS.



### R. A. KIPLING,

Importer of

## PRECIOUS STONES,

21 & 23 Maiden Lane,

19, RUE DROUOT,  
PARIS.

New York.



should not fail to spend an hour in the jewelry house of S. F. Myers & Co.

The new "Charmilles" watch, described elsewhere, promises to be accorded large sales as it meets the requirements of the masses for a well made, substantial watch at a low price. The "Charmilles" is all movement with just enough case to hold it, and is designed to put the value where it will do most good. Its stem winding and setting mechanism is as novel as it is simple; in fact the entire watch is such a novelty with the good points condensed, that it is bound to win its way into the estimation of the trade.

### Canada and the Provinces.

J. A. Julien, Montreal, is offering to compromise at 50 cents on the dollar.

A. B. Kaiser has been succeeded in Chesley, Ont., by Marshall Pearce.

A. L. Michaels, of Levy & Michaels, Halifax, N. S., accompanied by his wife, sailed for Germany on Saturday, Jan. 27th.

The Ontario Nickel Plating Works is the latest addition to Hamilton's industries. The plant is located at 258 Catherine St. N.

The jewelry store of Wm. Pott, Woodstock, Ont., was broken into early last Tuesday morning. The burglars became alarmed, and only got one or two small trinkets of no particular value.

Burglars in Montreal seem to be fascinated by jewelry stores. For the fourth time within a month, a jewelry store has been robbed. The latest sufferer is Dan Beatty, St. Peter St., who was robbed at an early hour last Monday. The plate glass window was smashed in and \$100 worth of goods was stolen. Mr. Beatty was in New York at the time of the robbery.

### Minneapolis and St. Paul.

W. H. Creveling, traveling salesman for the Reed & de Mars Jewelry Mfg. Co., Minneapolis, started out on his trip north last week.

J. R. Elliott, Minneapolis, last week removed from his old stand at 253 Nicollet Ave., into his new double store recently erected at 428 and 430 Nicollet Ave.

William Seng, St. Paul, for a number of years past with C. C. Bergh, as watchmaker, has accepted a similar position with Schunneman & Evans, that city.

A lighted lamp in the show window of L. Lehman's store, Minneapolis, exploded on the night of Jan. 26th, shattering a large French plate glass. The flames were extinguished with little damage to the store front.

Eastern manufacturers represented in the Twin Cities the past week were: Kent & Stanley Co., by M. C. Fish; R. Wallace & Sons Mfg. Co., Wm. Baker; Geo. A. Dean & Co., H. E. Kingman; Simpson, Hall, Miller & Co., F. W. Adams.

ESTABLISHED 50 YEARS.

RANDEL, BAREMORE & BILLINGS,

IMPORTERS OF

DIAMONDS,

AND OTHER PRECIOUS STONES.

FINE PEARLS A SPECIALTY.

MANUFACTURERS OF

DIAMOND JEWELRY,

IN THE LATEST DESIGNS.

Diamonds Recut in Modern Styles or Repaired on Premises.

58 Nassau Street,  
29 Maiden Lane  
NEW YORK.

1 Tulp Straat,  
AMSTERDAM.

1 St. Andrews St.,  
Holborn Circus,  
LONDON, E. C.



TRADE MARK.

ESTABLISHED 1841.

CARTER, SLOAN & CO.,

MANUFACTURERS OF GOLD JEWELRY,

No. 15 MAIDEN LANE,

NEW YORK.

A. CARTER, JR.  
A. K. SLOAN.  
C. E. HASTINGS.

GEO. R. HOWE  
WM. T. CARTER.  
WM. T. GOUGH.

FACTORY, NEWARK, N. J.



JOHN N. DISSELKOEN,

Cutter and Importer of

DIAMONDS

FACTORY.  
76 LANGEBLEEKERSPAD.  
AMSTERDAM.

19 East 16th St.,  
NEW YORK.

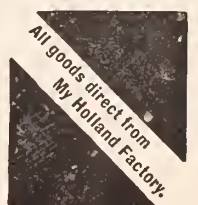

# THE JEWELERS' LEAGUE

Of the City of New York.

## THE BANNER SOCIETY OF THE TRADE.



A purely Mutual Benefit Association, organized in 1877, its sole object being upon the death of a member, to render pecuniary assistance to his family.

IT HAS PAID OUT SINCE THE DATE OF ITS ORGANIZATION  
TO THE BENEFICIARIES OF ITS MEMBERS, OVER **\$1,300,000**  
AND HAS ON HAND A RESERVE FUND OF **155,000**

No claim against the League has ever been disputed. The entire expense of management only 5 per cent. of its income.

### ITS OFFICERS FOR 1894 ARE

#### PRESIDENT.

HENRY HAYES, - - - of The Brooklyn Watch Case Co.

#### FIRST VICE-PRESIDENT.

JOSEPH B. BOWDEN, - - - of J. B. Bowden & Co.

#### SECOND VICE-PRESIDENT.

GEORGE R. HOWE, - - - of Carter, Sloan & Co.

#### THIRD VICE-PRESIDENT.

JAMES P. SNOW, - - - of Snow & Westcott.

#### FOURTH VICE-PRESIDENT.

JOHN R. GREASON, - - - of J. R. Greason & Co.

#### SECRETARY AND TREASURER.

WILLIAM L. SEXTON, - - - of Sexton Bros. & Washburn.

#### EXECUTIVE COMMITTEE.

WILLIAM BARDEL, (Chairman) - - - of Heller & Bardel.  
DAVID UNTERMEYER, - - - of Keller & Untermeyer.  
GEO. M. VAN DEVENTER, - - - of Waterbury Clock Co.  
WILLIAM H. JENKS, - - - with Tiffany & Co.  
A. A. JEANNOT, - - - of Jeannot & Shiebler.  
H. C. OSTRANDER, - - - with Randel, Baremore & Billings.

#### ADVISORY BOARD.

GEORGE W. PARKS, - - - of Parks Brothers & Rogers.  
CHARLES L. WHITE, - - - with Randel, Baremore & Billings.  
JOHN W. STEELE, - - - with C. G. Alford & Co.  
SAMUEL H. LEVY, - - - of L. & M. Kahn & Co.  
C. C. OFFERMAN, - - - with Wm. Smith & Co.  
RALPH HAMILTON, Jr., - - - of Hamilton & Hamilton, Jr.

#### EXAMINING FINANCE COMMITTEE.

BERNARD KARSCH, - - - of Bernard Karsch.  
D. P. ROSMAN, - - - of Groeschel & Resman.  
C. E. SETTLE, - - - with S. E. Fisher & Co.

**CHAS. H. HIGBEE,**

GENERAL AGENT OF THE JEWELERS' LEAGUE.

For Documents or Information of any kind in reference to the League, address  
Jewelers' League, P. O. Box 930, N. Y. City.





Traveling representatives may consider these columns open for the publication of any news or items of interest regarding themselves or their confreres.

**A.** W. PIERCE and W. F. Baker, representing the Winsted Optical Co., West Winsted, Conn., are both finding good business, the former in the south and the latter in New England.

S. B. Kent, of Wm. H. Ball & Co., has started on a short southern trip.

Benjamin Griscom, formerly traveling representative on the eastern circuit for Riker Bros., has accepted a situation with A. Stowell & Co., Boston, Mass.

H. F. Hahn & Co.'s travelers departed for their respective territories the present week; Emile Despres in the northwest, James D. Packard and M. Lebold in the west, and Steve H. Bridges in near-by territory, north and south.

Last week the following traveling men were in Indianapolis: J. R. Clarke, Self-Winding Clock Co.; L. H. Bosworth, Potter & Buffinton; W. G. Nerpel, Nesler & Co.; C. F. Willemin, H. Muhr's Sons; J. B. Osthoff, Jos. Noterman & Co.

The smiling face of Sam Schloss, traveling salesman for Weinmann Bros. & Co., Philadelphia, Pa., was bobbing around Washington last week. He is showing as a specialty a truly pretty and taking novelty in a neat plush box containing twelve set rings in new patterns.

The traveling fraternity was represented in Philadelphia, Pa., last week, by B. Schloss, A. Wallach & Co.; J. Williams, G. Armeny, T. G. Frothingham; Fred Clarkson; Snow & Westcott; Wm. Wightman, R. F. Simmons & Co.; H. Somers, Thos. Totten & Co.; C. H. Clark, J. G. Cheever & Co.; W. A. Watts, Rogers & Bro., and L. Stern, Young & Stern.

The following travelers were among those visiting Chicago jobbers last week: C. O. E. Hartung, Sussfeld, Lorsch & Co.; Sigmund Stern, Stern Bros.; A. Peabody; C. A. Boynton, Wm. B. Kerr & Co.; Geo. W. Bleecker, Bassett Jewelry Co.; Morgan R. Kavanagh John Russell Cutlery Co.; Wm. Mount, T. Quayle & Co.; Wm. P. Mockridge; Fred J. Foster, Unger Bros.; N. D. Prentiss, Alling & Co.; L. H. Bosworth, Potter & Buffinton; and R. A. Thompson, for Henry Glorieux.

Travelers in Boston, Mass., the past week included: Mr. Skinner, missionary for the Elgin National Watch Co.; Harry K. Ingraham, Alling & Co.; S. O. Bigney, Marsh & Bigney; W. H. Tarlton, Wightman & Hough Co.; T. B. Wilcox, Pairpoint Mfg. Co.; M. De Raimes, Newark, N. J.; T. F. Fessenden, Providence; E. A. Woodman

Potter & Buffinton; E. L. Spencer, E. L. Spencer & Co.; Henry G. Thresher, Waite, Thresher & Co.; W. R. Cobb, Pawtucket; A. A. Greene, Smith & Greene; Mr. Townsend, E. Aug. Neresheimer & Co.; Fred Miller, Shoemaker, Pickering & Co.; Ed. Ackley, Unger Bros.; Mr. Cole, Towle Mfg. Co.; Mr. Freese, Lewis, Kaiser & Luthy.

The following traveling salesmen passed through Detroit last week: Mr. Borgzinner, S & A. Borgzinner; Mr. Rodenberg, S. & B. Lederer; Mr. Jacoby, Providence Stock Co.; Samuel Fink, Fink, Bodenheimer & Co.; Henry Freund, Max Freund & Co.; E. Bloch, W. & S. Blackinton; Mr. Stratton, Jno. W. Reddall & Co.; Genl. Mindel, American Watch Case Co.; C. O. E. Hartung, Sussfeld, Lorsch & Co.; N. D. Prentiss, Alling & Co.; G. F. Kaiser, Enos Richardson & Co.; Mr. Krugler, H. H. Curtis & Co.; William D. Elcox, Larter Elcox & Co.; W. C. Coombs, E. F. Sanford & Co.; Louis P. Cook, J. F. Fradley & Co.; M. D. Rothschild; Mr. Gregory, Strobell & Crane; W. W. Middlebrook, B. A. Ballou & Co.; and S. W. Abbey, E. Ira Richards & Co.

### Worcester, Mass.

By reason of the fire in the Clark-Sawyer Co. store, that firm lost silverware, cut glass, and imported china valued at \$40,000.

C. M. McFarland & Co., 415 Main St., have leased the store 384 Main St., and it is being arranged for the occupancy by the firm Feb. 1st.

A. B. F. Kerney, president of the Worcester Fur Club, was in Freeport, Me., last week, attending the annual hunting meet of the Brunswick Fur Club.

At the session of the Superior Criminal Court Jan. 26th, Geo. F. Porter, of Spencer, was convicted of breaking into, and entering Chester Sylvester's jewelry store, in that place, and the larceny of \$75 worth of jewelry.

Judge Utley, of the Central District Court, recently heard the case of Libby vs. Friedman to recover \$203.08, alleged to be due on a note and check, and gave judgment in favor of the plaintiff for the full amount claimed. Rudolph Libby, the plaintiff, is a jeweler on Front St. The case has been appealed.

Dr. C. Wardwell Amerigs, of this city, is complainant in a suit for criminal libel against Albert E. Jeaneret, a watchmaker on Washington St., Boston. Some months ago Jonas E. Greeley, of this city, had Dr. Amerigs arrested for conspiracy in placing him in the Worcester lunatic hospital, where he was confined 36 hours, and then discharged. The prosecution is based on a letter written by Mr. Jeaneret to Mr. Greeley during the trial of Dr. Amerigs, making serious charges. Mr. Greeley showed it to several friends. Dr. Amerigs heard of it and had Jeaneret arrested. The letter mysteriously disappeared a short time ago.

### Philadelphia.

Bernard Levy, Wm. H. Moore, S. Hurlburt and J. A. Caldwell paid business visits to New York last week.

Henry Newburger, formerly with H. Muhr's Sons, has opened a jewelry establishment at 629 Chestnut St.

Simon Muhr is a member of the committee on music, and David F. Conover, of the committee on dinner, of the forthcoming banquet of the Five O'clock Club.

At the annual meeting of the stockholders of the Keystone Watch Case Co., the following directors were elected: John C. Lowry, Charles H. Banes, Richard A. Lewis, Edward Longstreth and Edmund Lewis.

The sale of the effects of the Philadelphia Optical & Watch Co. has been postponed ten days. An attachment was issued in Allentown, Wednesday, on the Philadelphia Optical & Watch Co. by A. H. Williams' Sons. The attachment is for goods, valued at \$250, belonging to the watch company, in the hands of Faust & Sterner.

The failure of the Philadelphia Optical & Watch Co. has resulted in some new business concerns. Sears & Fenimore have opened an establishment at 727 Sansom St. and have taken charge of all the repair work that had been in the hands of the embarrassed company. George W. Magee, E. A. Brown, H. C. Ulmer and A. R. McIntyre are arranging for a co-partnership under the name of McIntyre, Ulmer & Co., to conduct a jobbing, manufacturing and repairing business.

The funeral of Joseph H. Watson, one of the incorporators and secretary of the Quaker City Watch Co., occurred on the 31st ult. Many Philadelphians attended the services, which were held at the residence, 315 N. 6th St., Camden. The interment was private. For a number of years deceased was the treasurer and a member of the board of trustees of the Centenary Methodist Episcopal Church. He was in the jewelry business in Philadelphia, and was for a number of years connected with McCarty & Hurlburt, now H. O. Hurlburt & Sons.

On suspicion of being a diamond thief Chas. Weisenfeld, alias John Roach, of Buffalo, N. Y., was held on Friday by Magistrate Milligan, for a further hearing. The Buffalo police have telegraphed that the man is wanted for jewelry store robberies in that city. Local detectives watched him through the stores of J. E. Caldwell & Co., C. R. Smith & Sons, T. S. Mitchell & Co., S. & M. Fridenberg, Herzberg & Bros., Simons, Bro. & Co., Chas. Hirst and John C. Kelley. In each case the prisoner priced and examined valuable gems, but did not succeed in stealing anything.

Jas. H. Morse has purchased the stock of J. C. Lannerberg, Ilion, N. Y., and will continue the business. Mr. Lannerberg will devote his time to optical work, with headquarters at Utica, N. Y.



INDEX TO ADVERTISEMENTS, PAGE 102.

"Best" Eye Glasses.

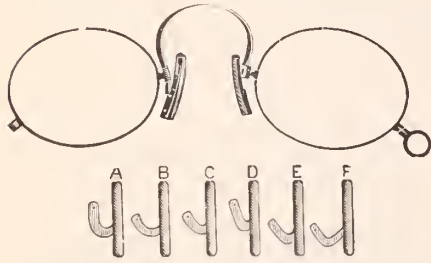

The "BEST" Guard embodies some new features of great value. The lower part is rigid, the upper part is flexible. Made in both shell and cork. Must be seen to be appreciated.

Sample Eyeglass Frame, in 10k. gold. - - \$2.90  
 " " " in Steel or Nickel, - .35  
 Sample Pair of 10k. Gold Guards, - .85  
 " " of Nickel Guards, - .15

Geneva Optical Company,  
 69 WASHINGTON STREET,  
 CHICAGO.

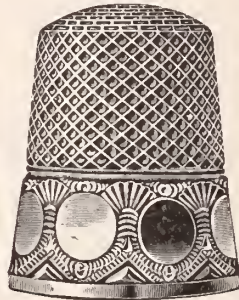

KETCHAM & McDOUGAL  
 MANUFACTURERS  
 GOLD & SILVER THIMBLES,  
 GOLD COLLAR BUTTONS,  
 AUTOMATIC EYE-GLASS HOLDERS  
 198 BROADWAY N Y

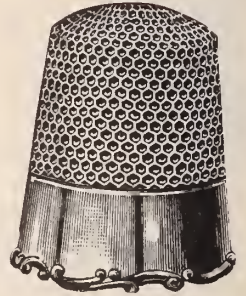

PATENT paneled METAL  
**CEILING**  
 Stamped Raised Panels.  
 ARTISTIC AND PERMANENT.

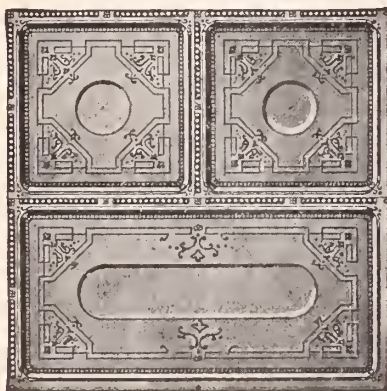

Easily applied in new buildings, and over old broken plaster or wood Ceilings. If interested in building or repairing, send stamp for Illustrated Catalogue, and state if CHURCH, HALL, STORE, OFFICE, or SCHOOL Ceiling is wanted. Address

A. NORTHROP & CO., Pittsburg, Pa.



IRONS & RUSSELL,

(SUCCESSORS TO CHARLES F. IRONS.)  
 MANUFACTURERS OF

SOLID GOLD EMBLEMS ROLL PLATE  
 PINS, CHARMS AND SOLID GOLD RINGS.



102 Friendship Street, - - Providence, R. I.

A. A. MARGOT.

E. F. MARGOT

MARGOT BROTHERS,

Watch Case Manufacturers, Engine Turners and Jobbers,  
 11 FRANKLIN ST. (FORMERLY 23 WATER ST.) BOSTON, MASS.

Special Attention to Watch Case Repairing, Springing, Re-engine Turning, Engraving, Polishing etc. Flat Glasses Fitted, Jewelry Silverware, Dies, etc., engine turned.

Particular Attention to Orders from Expresses.

We Have Removed to  
**57 MAIDEN LANE.**  
 LEONHARDT & CURRAN,  
 MANUFACTURERS OF DIAMOND MOUNTINGS.



JOHN N. DISSELKOEN,

Cutter and Importer of

**DIAMONDS**

FACTORY.  
 76 LANGEBLEEKERSPAD  
 AMSTERDAM.

19 East 16th St.,  
 NEW YORK.

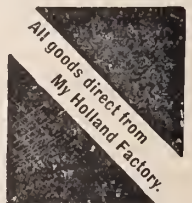

Enterprising Jewelers Catch On!



OVERSE



REVERSE



BACK

Jewish Sheckel, Masonic Mark or Pocket Piece.  
 THE LATEST AND BEST SELLING NOVELTY.

The mark is struck in coin silver; by using either the obverse or reverse of the coin, the back being the same in either case, and permitting of the purchaser's name, blue lodge, chapter and individual mark, with date of same being engraved thereon, as shown in cut above.

Price, without engraving, ONE DOLLAR. Engraved Mark, Dates, etc., 75c. EXTRA.

Liberal Discount to the Trade.

CHAS. G. WILLSON, MANUFACTURING JEWELER, READING PA.



# MERRILL BROS.,

MAKERS OF . . . .

—STERLING—

**SILVER  
NOVELTIES,**

**31 East 17th St.,**  
Union Square,  
**NEW YORK.**

Our Spring line for '94 is now complete, and contains many original novelties.

HEADQUARTERS  
FOR  
**Silver Mounted  
PIPES.**

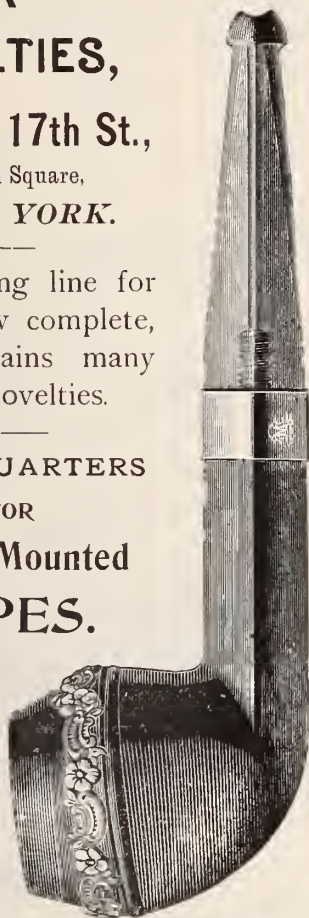

## W. F. Evans & Sons

**SOHO CLOCK FACTORY,**  
HANDSWORTH,  
BIRMINGHAM,  
ENGLAND

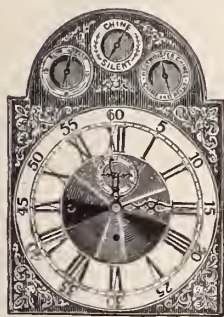

Manufacturers of  
**CHURCH,  
CHIME &  
QUARTER  
CLOCKS,**

**SCHOOL AND  
HOUSE CLOCKS**

With arch brass dials to chime upon  
Bells, Gongs, and Harrington's  
Patent Tubes.  
ESTABLISHED 1805.

## A. J. LOGAN,

MANUFACTURER OF  
WATCH TOOLS, HAIR SPRINGS AND  
**WATCH MATERIALS.**

◁ New Catalogue just issued, Sent on Application. ▷  
WALTHAM, MASS.

# Larter, Elcox & Co.

Manufacturers of Fine Gold Jewelry  
21 & 23 Maiden Lane, New York.



The Attention of the Trade is called to Our Line of

**GENTLEMEN'S RINGS** and **SEALS,**

with Intaglios, in **Jade, Jasper and Carnelian.** These goods are exceedingly desirable for this season's trade.

ALSO our full line of Misses' and Children's Rings finished in **Roman.**

**OUR SPRING BACK STUDS,** improved in construction, are now as near perfect as can be, and never so complete in variety of patterns.



Buy only the **L. E. & Co. Stud.**

# THE BOWDEN SEAMLESS RING

IS MADE ONLY BY

## J. B. BOWDEN & Co.,

Makers of Finger Rings of every Description  
**COR. BROADWAY & JOHN STREET,**  
NEW YORK.

## IF YOU WANT ANYTHING IN

GOLD, SILVER, STEEL AND NICKEL

# Spectacles and Eyeglasses,

Gold, Silver, Aluminum and German Silver

⇒ **THIMBLES!** ⇐

AND

Seamless Gold Filled Spectacles and Eyeglasses,

— **WRITE US!** —

# WINSTED OPTICAL CO.

MANUFACTURERS OF THE

Burbank Patent Eyeglass, Seamless Gold Filled Spectacles and Eyeglasses,  
AND ALL OTHER GOODS ENUMERATED ABOVE.

WEST WINSTED, CONN.

**SPRING**  
**ANNOUNCEMENT.**



**NOVELTIES**  
**IN STERLING SILVER.**

SCISSORS, TOILET SETS, SCENT BOTTLES,

ESPECIALLY.

CUPS AND SAUCERS COALPORT CHINA.  
COFFEE SERVICES OF RICH GLASS.  
BON-BON DISHES Decorated with Silver.  
SUITABLE FOR WEDDING GIFTS.

CABLE ADDRESS:  
RUBEOLA, NEW YORK.

**BACHRACH & FREEDMAN,**

**SILVERSMITHS,**

1 & 3 UNION SQUARE, NEW YORK.

CHICAGO OFFICE:  
24 ADAMS STREET.

**A. SCHWARZ,**

MANUFACTURER OF

Fine Cases for  
Jewelry & Silverware

OF EVERY DESCRIPTION,

In Velvet, Leather, Kid, Chamois, Silk, Etc.

866 BROADWAY,

FACTORY: NEW YORK  
51 & 53 WEST 13TH ST.

POLISHED CHESTS, TRAYS, RACKS, Etc.

Fine Satin, Plush and Velvet-Lined or Unlined Paper Boxes of every description, for Jewelers and Silversmiths.

NEW! IMPROVED NEW!  
Adjustable "Eclipse" Eye Glasses.

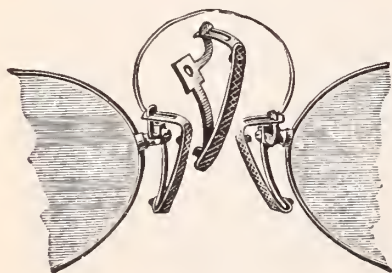

PATENT APPLIED FOR.

We claim this invention to be the only one which combines the advantages of both the adjustable and offset guards. We will furnish these frames or guards in either Zylonite or Cork.

WRITE FOR CIRCULAR.  
JOHN SCHEIDIG & CO., SOLE AGENTS  
43 MAIDEN LANE, NEW YORK.

**J. HERZOG & Co.**  
IMPORTERS OF  
**STERLING SILVER AND FINE SILVER PLATED NOVELTIES**  
ENGLISH, FRENCH, GERMAN, AUSTRIAN AND ITALIAN WARE  
8 MAIDEN LANE, NEW YORK.

NATHAN KOCH.

LEON DREYFUS.

I. PFORZHEIMER.

**KOCH, DREYFUS & CO.,**

**IMPORTERS OF DIAMONDS,**

And Jobbers in American Watches and Jewelry,

22 JOHN STREET, NEW YORK.

**BIG RETURNS MADE FOR OLD GOLD AND SILVER.**

Check Forwarded 24 Hours After Receipt of Consignment.

**J. RATHBONE,**

GOLD AND SILVER REFINER, ASSAYER AND SWEEPSMELTER,  
Nos. 1 to 9 Matthewson St., Cor. Cove, Providence, R. I.



WESTERN SUPPLEMENT OF  
THE JEWELERS' CIRCULAR

Chicago Office Room 308, Inter-Ocean Building.

VOL. XXVIII.

CHICAGO, WEDNESDAY, FEBRUARY 7, 1894.

NO. 1.

### Chicago Notes.

E. E. Kipling has filed an assumpsit suit against Adolph Pentz for \$1,000.

Abe Steinau, Jr., late of Cincinnati, was seen on the streets of Chicago the past week.

C. F. Willemin, of H. Muhr's Sons' ring department is working his way east on his return trip.

Charles Hoefler, of Woodstock, Barger & Hoefler, Kansas City, Mo., visited his many friends here last week.

Assignee Gary, of F. E. Morse & Son, has been ordered by court to return certain ring mountings to J. Milhening.

I. Speyer, representing Goldsmith Bros., returned the past week from his southern trip with reports of a quiet feeling in all the larger cities of the south.

E. A. Giles, receiver for Giles, Bro. & Co., has been ordered by the United States Circuit Court to pay the First National Bank \$15,000, to be applied upon its judgment.

The Rhoads & Loftis Jewelry Co., doing a retail business on the fifth floor of the Masonic Temple, have certified to a dissolution of the organization and surrendered their charter.

M. S. Fleischman, wholesale jeweler, 178 Market St., Jan. 28th, filed an assumpsit suit in the Circuit Court against Wm. Nejedly for \$1,000. Nejedly owes Fleischman \$400 on open book account.

F. J. Essig, lapidist, room 1222, Masonic Temple, will place a traveler on the road the coming week to visit western cities with the most complete line of Montana sapphires ever presented to the jewelry public.

F. H. Noble will spend February at the Mid-Winter Fair. R. Kehl, of F. H. Noble & Co., will remain in San Francisco till the Fair closes. The firm have the sole concession for the sale and manufacture of aluminum goods at the Fair.

E. P. Sundberg, Fargo, N. Dak., has given confessions of judgment aggregating \$8,000—\$6,000 to a sister, and \$2,000 to the First National Bank of Fargo. Attorneys for

creditors think he will try to effect a compromise. It is not believed the stock is sufficient to pay the judgments.

The United States Marshal will sell a case of garnet jewelry at public auction on the steps of the Adams St. end of the Government building on Feb. 8th. The jewelry was imported from Austria by A. Klein, but was seized by the customs officers because it was undervalued by the importer. The jewels are worth about \$350.

Six assumpsit suits were filed in the Circuit Court Wednesday against Adolph Shakman by Peckham & Brown, attorneys for the Manufacturing Jewelers' Board of Trade as follows: Watson, Newell & Co., \$5,000; Hancock, Becker & Co., \$700; Smith & Crosby, \$400; Wightman & Hough Co., \$1,000; Horton, Angell & Co., \$4,000; R. L. Griffith & Son, \$1,000; total of \$12,100. Shakman failed some months ago, though considered well off at the time, and the suits are brought to obtain judgment.

Albert E. King, of King & Thompson, stopped over a few days in Chicago on his way from London, Eng., to the Mid-Winter Fair, where he will join Mr. Thompson in the management of the firm's exhibit in the British section of Manufactures building. Mr. King was manager for the Goldsmiths' and Silversmiths' Co's, of London, and Mappin Bros.' exhibits at the World's Fair. King & Thompson exhibit at the Mid-Winter Fair a line of silver and jewelry, including antique plate and a pair of Spanish ram's head silver candlesticks of the time of George II.; also the Shakespearean casket formerly illustrated and described in THE CIRCULAR.

Henry A. Spaulding, president of Spaulding & Co., has tendered his resignation to the board of directors of the corporation. The reason assigned is a need of rest, Mr. Spaulding having worked indefatigably to bring the company to its present high position in the retail trade. The stock held by him will be purchased by the corporation; but the name, being incorporated, will not be changed. The fiscal year ends Feb. 15, and the resignation will be accepted at the board meeting then held. Mr. Spaulding and family will leave the latter part of

the month for the Continent, and a tour of Japan is stated to be among the probabilities of the trip. After their travels, which will continue until the Fall, the family will settle in New York.

Hardinge Bros., successors to the Horological Tool Co., 1036 Lincoln Ave., is the title of the new company manufacturing the Dale chucks and other valuable watch tools. The company is new in name only. Jan. 26th Stephen Dale, president of the Horological Tool Co., disposed of all his interests in the company to the Hardinge brothers, his co-workers in developing the plant. It was decided to make no change in the list of officers at present. The Messrs. Hardinge now own all the stock of the corporation, and will continue the manufacture of their specialties at 1036 Lincoln Ave., having leased the building and ground for a period of five years. Mr. Dale will leave for California in a few months, and with ample means will pass the remainder of his life in comfort under his own vine and fig tree. Hardinge Bros. will retain the word "Dale" on chucks to distinguish their product.

Miss Mildred Lehmann, daughter of Mrs. E. J. Lehmann, and Charles Daniel Peacock, Jr. were united in marriage Jan. 30, at the residence of the bride's mother, 309 Michigan Boulevard. The bride is a young lady of rare loveliness. Mr. and Mrs. Peacock left at 10.30 for a two months' trip to the Mid-Winter Fair and Southern California. Five hundred invitations were issued. Among those present well known in jewelry circles were noted Messrs. and Mesdames C. D. Peacock, Otto Young, J. A. Todd, Julius Schnering, Elmer E. A. Rich, Harry Stevens, M. E. Capelle, John Schaub and Adcock, Will Jurgens and sister, Dave Thatcher and daughter, Paul Jackson and sister, Mrs. E. J. Lehmann and Messrs. J. Milhening, C. A. Boynton, Oscar Frederick Engwall, Wm. Nethercott, Walter Buffinton, L. D. Conwell and A. W. Jewell. The presents were most complete and wisely selected, comprising collections of silver, cut glass, statuary, furniture and fine china. A large diamond star pendant was presented to the bride by the groom's father.



**Indianapolis.**

T. W. Gardner has given a chattel mortgage for \$500.

H. D. Burgheim left for the east Feb. 1st, to purchase new goods.

Jos. E. Reagan made a business trip to Effingham, Ill., last week, for Baldwin, Miller & Co.

H. M. Rich, who conducted a successful auction sale for Wm. J. Eisele, last month, has returned to Boston, Mass.

E. C. Miller, of Baldwin, Miller & Co., will shortly leave for Hot Springs, Col., in search of relief from rheumatism.

Will Todd has taken charge of the optical department of Everson & Todd's jewelry store, Madison, Ind. Mr. Todd is a graduate of the Chicago Ophthalmic College.

Indianapolis jobbing houses will send out their traveling men about Feb. 10th. Baldwin, Miller & Co. will be represented by David Reagan in Illinois and the west, and by Chas. W. Lauer in Indiana and the south; Nichols, Pee & Co. will be represented by Elliot Sims in the States west of Indiana, and by John Gardner in Indiana and Ohio; Fred Zwicker will represent Fred H. Schmidt & Co.; L. L. Norton's material and tool house will be represented by Leslie Norton, and Tom Moorhead will represent T. L. Moorhead.

A. H. Peacock, Dallas, Tex., has filed a deed of trust, preferring all his creditors. The liabilities are placed at \$5,000 and the assets at \$7,000.

**Detroit.**

Henry F. Anthony started out last Monday on a trip through Michigan for L. Black & Co.

Fire was discovered last Tuesday in the jewelry store of Peter Merckenich, 720 Gratiot Ave. It was extinguished with slight damage.

L. B. Colwell returned from Chicago last Sunday. He started out again for a trip through Canada and will come back via Buffalo.

George W. Stephens, jeweler, Port Huron, Mich., last week gave a chattel mortgage covering his entire stock and fixtures to Kennedy & Koester, this city.

General business in this locality is improving rapidly. The big factories are resuming. The following Michigan jewelers were here last week: W. Ambler, Northville; and E. Campbell, Pinckney.

The Burt & Hurlbut Co., who recently filed a chattel mortgage for \$15,661 on their stock and fixtures, in favor of local creditors, made their annual report last week: Capital stock, fully paid in, \$15,000; real estate, \$1,295.01; personal property, \$20,182.95; debts, \$35,080.29; contingent liabilities, \$2,638.78; credits, \$9,352.56. All corporations are required by law to file an annual report with the county clerk.

It is definitely settled that L. Black & Co., wholesale opticians, New York, will move their stock and plant to this city on or about April 1st. The firm will have offices in the Woodward Ave. store of L. Black & Co. The wholesale department will occupy the basement. A. Landsberg, principal owner of the New York concern, and wife returned east last week, after inspecting the branch business here.

The Elgin National Watch Co. posted notice Jan. 30th that the factory would run four days a week, commencing Feb. 1st, instead of three days as theretofore.

**C. F. HAPPEL & CO.,  
WHOLESALE JEWELERS,  
86 & 88 State Street,  
3d Floor. Take Elevator.  
CHICAGO, ILL.**

No Retailing.

No Cata'ogue.

**Specialties.**

**Montana  
Sapphires,  
Topazes,  
Turquoise**

and all Precious  
and Semi-Precious  
Stones and their  
cutting.

AWARDED  
MEDAL ON  
MONTANA  
SAPPHIRE AND  
TOPAZ  
CUTTING AND  
EXHIBIT OF  
ROUGH STONES  
AT THE  
WORLD'S FAIR.



### F. E. Morse & Son's Stock and Fixtures Sold to A. A. Johnson.

CHICAGO, Ill., Feb. 3.—The stock and fixtures of F. E. Morse & Son were sold to the highest bidder at the County Court room Wednesday. Three bids were opened by the assignee in open court: Randel, Baremore & Billings, \$25,000; American Exchange, First and Atlas National Banks, combined, \$25,000; A. A. Johnson, \$25,750. After the announcement of the sealed bids Assignee Gary asked for increased or additional bids. The sum was quickly raised to \$28,000 and the banks dropped out. Randel, Baremore & Billings and A. A. Johnson continued the bidding, and the diamond firm failing to raise Johnson's bid of \$35,500, the sale was concluded. Johnson's attorney deposited with the assignee \$5,000 as earnest money on account.

The total liabilities of F. E. Morse & Son were between \$90,000 and \$100,000, and contingent liabilities carried the amount to \$108,000. The stock and fixtures disposed of by Wednesday's sale cost \$71,000, and had an estimated value of \$60,000. About \$3,000 worth had been sold by the assignee before the goods were stored, leaving some \$57,000 worth which sold for \$35,500. The total value of assets to be divided among creditors cannot be determined until all accounts have been passed upon and admitted by the court.

Diamond men have never heard of A. A. Johnson and the city directory shows no one of that name who would be likely to have \$35,500 in his pockets. To every inquiry THE CIRCULAR correspondent was advised to see Mr. Morse. Mr. Morse pleads ignorance of the whole affair.

### Liabilities and Assets of B. B. Marshall & Son.

MINNEAPOLIS, Minn., Jan. 30.—The schedules of assets and liabilities of B. B. Marshall & Son were filed Jan. 22d, by the assignee, Geo. R. Robinson. They show liabilities of \$8,772.07, with assets amounting to \$10,379.25. The following is a correct list of creditors:

Fink, Bodenheimer & Co., \$49.27; James E. Cox, \$238.95; Minneapolis Gas and Electric Co., \$46.17; American District Telegraph Co., \$15.50; Journal Printing Co., \$9; State of Minnesota, \$36.41; First National Bank, \$385; Mary Howell, \$3,000; Towle Mfg. Co., \$250.89; Waterbury Clock Co., \$56.75; Barbour Silver Co., \$289.64; Pairpoint Mfg. Co., \$1,424.41; M. B. Bryant & Co., \$99.38; Kent & Stanley Co., \$70; Carter, Sloan & Co., \$33.60; Henry Cowan, \$421.82; M. C. Eppenstein & Co., \$207.45; A. W. Cousins, \$4.96; H. M. Loughbridge, \$23.85; C. G. Alford & Co., \$200; C. Preusser Jewelry Co., \$53.82; First National Bank, \$1,500; C. H. Babcock, \$4,000; total, \$8,772.07.

The assets are itemized as follows: Furniture and fixtures, \$800; store, building and ground lease, \$4,000; real estate, \$400; bills receivable, \$2,196.65; open accounts outstanding, \$1,001.50; merchandise, stock, \$1,982.09; total, \$10,379.25.

### Additional Contributions for Charity by Chicago Jewelers.

CHICAGO, Ill., Feb. 2.—Additional subscriptions to the relief fund of the jewelers' branch of the Central Relief Association, follow: American Waltham Watch Co., in full, \$250; J. J. Altpeter, chairman, \$51; Juergens & Andersen Co. employes, \$200; Lapp & Flershem employes, \$131; Wm. L. Gilbert Clock Co., \$50. The following agree to pay the sums stated for each month of four months, if necessary: Dennison Mfg. Co., \$25; Alfred H. Smith & Co., \$25; Towle Mfg. Co., \$25; R. Wallace & Sons Mfg. Co., \$25; H. M. Carle, \$5.

The following subscribed for a total amount, and not for each month, as reported in last week's CIRCULAR: Crescent Watch Case Co., Elgin Natl. Watch Co., Gorham Mfg. Co., B. F. Norris, Alister & Co., S. N. Jenkins, M. A. Eiseman & Bro., G. H. Fuller & Son, J. H. Mather, and Spaulding & Co.

Employes are asked to contribute one day's pay, not one day's pay each month. A revised list of subscriptions to date shows a total of \$15,215.

### The Stock of Frank S. Ring Sold at Auction.

DETROIT, Mich., Feb. 2.—The stock and fixtures of Frank S. Ring, wholesale and retail jeweler, 68 Woodward Ave., were sold at public auction yesterday, for \$7,350, to Mr. Whiting, agent for Allison L. Hitchcock. It is understood that Arnold & Steere are the owners, however, as they hold the two first mortgages, amounting to \$7,557, and are included in the third to the amount of \$4,075.08, as stated in last week's CIRCULAR.

There were several who desired the stock and the bidding was brisk, until Mr. Steere

put a damper on their enthusiasm by stating that his firm had sold Mr. Ring nearly \$4,000 worth of rings that were subject to replevin. Whoever bought in the stock must take this into account.

It has not been decided as to who will run the business. Mr. Whiting of Bower, Douglass & Whiting, attorneys for Mr. Hitchcock, says the business will be continued. The matter will be decided in a few days.

### The Donelson Jewelry Co.'s Assets and Liabilities.

MINNEAPOLIS, Minn., Jan. 31.—The schedules filed Jan. 23d, by P. D. Boutelle, assignee of the Donelson Jewelry Co., show liabilities to be \$2,846.65 and assets \$4,347.50. The list of creditors is as follows:

L. L. Gording, \$46; Western Electric Co., \$48.25; C. T. Anderson, \$46.69; J. R. Wood & Son, \$55.23; Heintz Bros., \$271; Mandroult & Co., \$325.40; Ketchum & McDougall, \$78.95; Wendell Mfg. Co., \$120.60; Frank H. Wells, \$36; Bradley & Hubbard Mfg. Co., \$181; B. Veit, \$39.15; Kent & Stanley Co., \$286.01; Dirkson Filigree Co., \$76; W. C. Moore Bronze Co., \$81.25; W. Rosenthal, \$42.57; Blair Furniture Co., \$147.51; Hildreth Mfg. Co., \$105.09; Cleveland Optical Co., \$299.70; Gorham Mfg. Co., \$19.85; Attleboro Falls Chain Co., \$105.10; G. W. Cheever & Co., \$33.83; Aikin, Lambert & Co., \$160.02; E. S. Johnson & Co., \$106.35; Isaac Cole, \$253.13; Wilk & Hermans, \$62.70; Champenois & Co., \$461.15; Parsons & Greene Co., \$48.12; S. A. Brossonell, \$10.38; L. Black & Co., \$128.25; Geo. E. Wallinger, \$79.62; D. De Sola Mendes & Co., \$278; Alfred H. Smith & Co., \$163; J. N. Provenzano, \$261; J. W.

## REED & BARTON,

### SILVERSMITHS,

MANUFACTURERS OF

STERLING <sup>and</sup> SILVER PLATED  
SILVER <sup>and</sup> WARE.

SALESROOMS:

37 Union Square, New York.

34-36 WASHINGTON STREET,

Venetian Building, Chicago.

FACTORIES, TAUNTON, MASS.

# Juergens & Andersen Co., DIAMOND

125 & 127 State Street,

CHICAGO.

IMPORTERS  
AND  
MANUFACTURING

## JEWELERS.

25 Looijersgracht, - Amsterdam, Holland.



**HARDINGE ROLLER REMOVERS,**  
THE BEST ON EARTH.

MANUFACTURED BY

**HARDINGE BROS.,**

Successors to HOROLOGICAL TOOL CO.,  
1036 LINCOLN AVE., CHICAGO.

For Sale by all Jobbers.

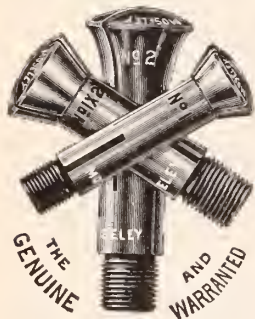
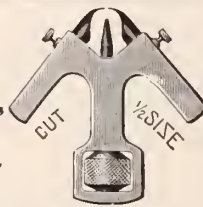

**1892. GRAND DROP NUMBER TWO. 1894.**

All Genuine Moseley No. 1, No. 1x2 and No. 2 Chucks are now listed at \$1.00 each.

IMPROVED TOOLS ENABLES US TO DO THIS. QUALITY GOING UP AND PRICES GOING DOWN.

Good Chucks and more of them are what the watchmaker and repairer needs to do their work correctly and more rapidly. We do not reduce the price or quality of the lathes, but add more than enough chucks to the combinations to make up for the reduction of the chucks.

7 Chuck Combination, \$42.00.	-	-	-	-	Now, 10 Chucks, \$42.00
10 " " " " " "	46.00.	-	-	-	" 14 " " 46.00
15 " " " " " "	51.00.	-	-	-	" 20 " " 51.00
25 " " " " " "	71.00.	-	-	-	" 33 " " 71.00
33 " " " " " "	80.00.	-	-	-	" 42 " " 80.00
48 " " " " " "	106.00.	-	-	-	" 60 " " 106.00

**MOSELEY & CO.,** - 36 River Street, Elgin, Ill.

Will take effect Jan 20th, 1894.  
When interested write your Jobber, or

**CHAS. H. PFEIL,**  
MANUFACTURING JEWELER.  
Diamond Work a Specialty.

**BEST of Workmen.**  
**BEST Design Work.**  
**GUARANTEED Workmanship.**

Send a trial order and be convinced.

**182 State St., Chicago.**

**HUGO MUELLER,**  
**182 State St., (Room 70,) Chicago.**

**FINE WATCH REPAIRING**  
IN ALL ITS BRANCHES.

Work for the trade promptly executed by skilled workmen.



## OPTICIAN'S SCHOOL.

The Chicago . . .

**OPHTHALMIC COLLEGE**

. . . and Hospital.

**607 Van Buren Street.**

**B**EING the oldest and most favorably known College of Theoretical and Applied Ophthalmic Optics in America, having more thoroughly qualified opticians in the field than all other so-called schools combined.

From having had the most experience, we can honestly guarantee the best satisfaction to earnest students, and we do not care for others, as we desire our students to be considered the best. Our diploma is recognized throughout America as conferring superior optical knowledge.

Opticians are admitted to the Hospital and may witness several cross-eye and cataract operations during the session, as well as having the advantage of personally examining and correcting all errors of refraction, muscular inequalities, etc., under the supervision of the attending oculist.

March 6, 1894, next class begins; already 16 names are registered. If you want a *good roof* over your head, come to our school. We want **earnest students**, *leave the rest to us*, we do not want diploma hunters.

See notice of January Class in CIRCULAR, of January 31st, February *Keystone* and *Chicago News*.

ADDRESS THE PRESIDENT,

**H. M. MARTIN, M. D.,**

607 VAN BUREN ST.

CITY OFFICE,

103 STATE ST., COR. WASHINGTON,  
COLUMBUS MEMORIAL BUILDING

SUITE 901.



Sherwood, \$78; Fabian Knife Co., \$66; R. L. Moorhead & Co., \$308.22; Schloss Bros., \$77.25; Meriden Britannia Co., \$363.01; Manhattan Silver Plate Co., \$17.25; Osborn & Co., \$88.43; Le Boutillier & Co., \$179.50; Holden & Knox, \$414.76; Geneva Optical Co., \$199.50; New Jersey Lamp & Bronze Co., \$55.19; Gilbert T. Woglom, \$6.98; Duryea Jewelry Co., \$43.25; Rogers, Smith & Co., \$55.19; Chas. Jacques Clock Co., \$34.68; C. F. Rump & Sons, \$232.46; S. W. Bassett, \$40.20; M. J. Sheriden, \$210; Edwin C. Wiley, \$231.39; Leopold Weil & Co., \$112.

#### L. B. Colwell Aids in Capturing a Noted Crook.

DETROIT, Mich., Feb. 5.—For several months, the police of this city have been puzzled by the occurrence of a number of robberies of a similar character, in which the thief entered the house of a prominent citizen and invariably carried away nothing but solid silverware. The total value of goods stolen amounted to \$1,000.

Last week Detectives Myler and Tuttle received word from L. B. Colwell, of L. B. Colwell & Co., gold and silver refiners, that he had purchased a quantity of silverware from a man who said he was a retired jeweler. The officers hurried over and recognized it as a part of the plunder stolen recently from the house of Putler Ives. They camped out in the store and the next day were rewarded by catching the thief. He would not divulge his name or place of residence. The officers soon found out, however, that his name is Keith Hacker, a noted crook of Kingston, Ont. Nearly all the plunder was recovered at his room, 31 Champlain St.

#### Pacific Coast Notes.

C. H. Clark has located at Forbestown, Cal.

Montana has shipped two carloads of gems and minerals to be exhibited at the Mid-Winter Fair. Among the exhibits will be \$40,000 worth of gold nuggets.

A. Openheim's store, San Francisco, was the scene of a small robbery a few nights ago. Tom Capperman was the name given by the party who snatched a watch from the counter and ran away. He was caught with the stolen plunder in his possession.

Davenport, Wash., claims to be enriched by the discovery of a valuable opal mine near that place. L. H. Jansen, who made the discovery, has organized a company, acquired 160 acres of land and proposes to operate the mines immediately.

The directors of Shreve & Co., San Francisco, whose incorporation was last week reported in THE CIRCULAR, with amount of stock subscribed by each are as follows: Geo. Bonny, \$100,000; Rebecca R. Shreve, \$50,000; Albert J. Lewis, \$250,000; Geo. R. Shreve, \$50,000; Chas. J. Foster, \$50,000. The capital stock is \$500,000.

Rumpf & Mayer, Seattle, Wash., have brought suit against Barto & Smith to recover a pair of diamond earrings and two diamond rings of the value of \$350. It seems that one Rackart represented to Rumpf & Mayer that he had a customer for the jewelry. While they were in his possession they were pawned with Barto & Smith by a third party for \$250.

J. H. Padgham, Sr., member of the firm of Padgham & Son, Santa Ana, Cal., died on the 16th. Deceased was 65 years old, was born in England and came to the United

States at the age of two years. He had been engaged in the jewelry business in California for eight years. He was one of the most highly respected citizens of Santa Ana and his death was regarded as a serious loss to the business community.

#### Kansas City.

Flint Bowen, agent for the Wm. L. Gilbert Clock Co., and the Wendell Mfg. Co., has opened his office at 618 Keith & Perry building.

Thieves broke into T. B. Newton's store, 100 Walnut St., and stole a lot of plated chains, rings and lockets. The theft was reported to the police.

H. W. Selts, Clay Center, Kan.; A. J. Smith, Emporia, Kan.; J. S. Burson, Belton, Mo.; and W. W. Whitesides, Liberty, Mo., were in Kansas City last week buying goods.

The annual meeting of the Edwards & Sloane Jewelry Co. was held February 2d. H. F. Sloane was re-elected president, Herman Oppenheimer, vice-president, and George H. Edwards, secretary and treasurer.

Frank Robinson was arrested a few days ago for robbing the Rex Jewelry Store of the Arnold Jeanneret Co, 533 Minnesota Ave., Kansas City, Kan. He had nine rings in his pocket, and seventeen which he had sold were recovered.

E. Hayter and G. H. Brucker, jewelers, in the Gilliss Opera House building, have been made defendants along with 20 of the wealthiest men and corporations in the city, in a suit brought by Antoine Gilliss last week to break the will of William Gilliss, who died 25 years ago.

# B. F. NORRIS, ALISTER & CO.

OFFER TO THE TRADE

REDUCED PRICES ON

WEBSTER WHITCOMB LATHE OUTFITS.



REDUCED PRICES ON

MOSELEY NO. 2 LATHE OUTFITS.

AT LESS THAN MANUFACTURER'S COST IS THE NEW REDUCED PRICE ON

Razzle Dazzle 8 Day Clock Assortment. The new Reduced Prices on World's Fair 8 Day Clock Assortment, all Gong Strike.

WRITE TO US FOR PRICES.

113 & 115 STATE STREET, CHICAGO, ILL.

# Clemens Hellebush, MANUFACTURING JEWELER.

JOBBER IN American Watches.

MATERIAL A SPECIALTY.

CINCINNATI, - - - - - OHIO.

**R. M. JOHNSON,**  
IMPORTER OF  
**Diamonds AND Manufacturing Jeweler,**  
67 WASHINGTON STREET,  
ROOMS 5 & 6,  
CHICAGO.  
MASONIC EMBLEMS OF EVERY DESCRIPTION MADE TO ORDER.

**G. A. WEBSTER**  
42 & 44 Madison St., Chicago, Ill.  
**Manufacturer**  
AND WESTERN AGENT FOR  
E. G. WEBSTER & SON, of Brooklyn, N. Y.  
A. F. TOWLE & SON CO., of Greenfield, Mass.

ESTABLISHED 1879.

**G. W. HOOK,**  
MANUFACTURING JEWELER,  
149 & 151 State St.,  
Chicago, Ill.

## OPTICAL DEPARTMENTS ESTABLISHED.

An EXPERT OPTICIAN will thoroughly establish an Optical Department in a limited number of FIRST CLASS JEWELRY STORES, giving his own time as promoter until on a successful basis. Will also give complete instructions in fitting to the man designed as head of the department.

**THERE'S MONEY IN IT.**

Jewelers wishing to make a special run in their optical department or establish one, will find this a rare opportunity. Your business can be increased \$1,000 to \$2,000 a month. Arrangements can be made either on percentage or salary. An unusual opportunity for a good house to

**ENTER A LUCRATIVE FIELD.**

ADDRESS  
**OPTICIAN, Care JEWELERS' CIRCULAR, Chicago Office,**  
**308 INTER-OCEAN BUILDING, CHICAGO.**

## DUEBER-HAMPDEN WATCHES.

The most reliable watches are the Hampden 17 Jewel. A full line of Dueber Cases and Hampden Movements. Cash buyers write us.

**BRETHAUER WATCH & JEWELRY COMPANY,**  
SPECIAL AGENTS,  
21 WASHINGTON ST., - - - CHICAGO, ILLS.

**PEARLS.**  
DIAMONDS, RUBIES, SAPPHIRES,  
**TATSCH & WILD,**  
Precious Stone Importers,  
EMERALDS, TURQUOISE, OPALS, ETC.  
**101 STATE ST., CHICAGO,**  
European Office: Tatsch & Wild, Idar, Germany.

**WILLIAM TERNENDT,**  
**GOLD AND SILVER PLATER,**  
96 STATE STREET,  
ROOM 508, CHICAGO.

**READ, STUDY** your own interests.

WATCH MATERIAL CABINETS ARRANGED AS YOU LIKE.

IF YOU WANT **FITS** ORDER OUR CABINETS. MATERIAL AT COMPANIES' PRICES. NO CHARGE FOR CABINETS.

<b>BALANCE JEWELS.</b>	<b>BALANCE ARBORS (Staffs)</b>
<b>A</b> —2 doz. most used Elgin and Walt. \$4 50	<b>E</b> —2 doz. most used Elgin and Walt. \$4 00
<b>B</b> —2 doz. most used Imitation Elgin & Walt. Fine Ruby, 3 00	<b>F</b> —2 doz. most used Imitation Elgin & Walt. Ex. qual. 3 50
<b>C</b> —2 doz. most used Imitation Elgin & Walt. Garnet, 2 25	<b>G</b> —3 doz. most used Imitation, 2 25
<b>D</b> —2 doz. most used Imitation Elgin & Walt. Common, 1 50	End Stones most used 2 doz. Elgin and Walt. 2 50
	2 doz. Imitation Elgin and Walt. 2 00



**PIN JEWELS,** 4 doz. all kinds, real, \$2 40  
" " 6 " " Imitation, 1 60  
**IMITATION BALANCE ARBORS, (Staffs)**  
good quality, - - 75 cents per doz.

ANY OTHER COMBINATION AS DESIRED.

Send US all your orders for Watch Material.

**J. H. PURDY & CO.,**  
9 TO 13 MONROE STREET,  
CHICAGO.

**A. C. BECKEN,**  
**WHOLESALE JEWELER**

We handle everything required by the Jewelry Trade.  
Dueber-Hampden Watches a Specialty.

Send for Mammoth Illustrated Catalogue and Net Price Lists, also circular explaining new plan of rebates on seventeen jeweled Hampdens.

**COLUMBUS MEMORIAL BUILDING,**  
103 State Street, - Chicago.

**THE PLANCHAMP & BECKER CO.**  
Makers and Repairers of  
**WATCH CASES,**  
Gold and Silver Plating —  
— of Watch Cases a Specialty.  
UNEXCELLED FACILITIES.  
63 and 65 East Washington St., Chicago.



WHEN IN CHICAGO, VISIT THE  
**Chicago Watchmakers' Institute,**  
SUITE, 1521-1523 B MASONIC TEMPLE.  
A Modern Trade School for the Watchmaker, Jeweler and Engraver. Write for New Catalogue.



**Cincinnati.**

The 16 size hunting, engraved Bell watch cases are having a large sale.

C. P. Bristol, of the C. Rogers & Bros., Meriden, Conn., was here last week.

S. A. Otis, of Harvey & Otis, Providence, was around among the trade last week.

C. E. Hodgens, of O. E. Bell & Co., started out on a four weeks' trip last week.

Jos. Noterman has returned from a month's outing in the North Carolina mountains, looking rejuvenated.

H. A. Wadsworth and H. C. Walton, president and secretary of the Wadsworth Watch Case Co., have returned from a trip east.

The Braham Jewelry Co.'s door was found open at midnight, Friday, by the officer patrolling that beat. Nothing seemed disturbed, although it was evident some one had been within the store.

B. Greenwald, manager of the American Watch and Jewelry Co., at 4th and Plum Sts., was arrested on charge of petit larceny last week on a warrant granted at the request of Alice West, who bought a watch of him on the instalment plan, agreeing to pay \$28. She had paid \$10, when she learned from another jeweler that the watch was worth about \$4. She went to Greenwald for an explanation, and he took the watch, refusing to give up either money or the watch.

**Columbus, O.**

Thomas T. M. Koch, assignee of Peter M. Koch, has been authorized to sell the stock of jewelry at private sale.

Charles A. Klie, Fred Lazarus, Dr. J. C. Schueller, William Riel and H. C. Godman, old stockholders, have issued a circular setting forth the advantages of a reorganization of the Columbus Watch Co. Some of the heaviest stockholders have signified a willingness to invest more money and try the watch business again under new management. The entire outfit, including valuable machinery, can be bought for two-thirds the appraisal.

The Union Jewelry Co. the past week filed their answer in the suit brought by I. Ollendorf, Pittsburgh, Pa. The answer says that prior to the date of the draft sued upon they had given a promissory note for about \$150, which plaintiff had discounted at Pittsburgh, for which no consideration was received. When the note became due it was forwarded to a Columbus bank and presented for payment. Defendants declined to pay it and plaintiff instructed defendants to draw on him for the amount, which was done and the draft paid, and the amount, according to instructions, paid on said note. Defendants says that in the discounting of said note plaintiff received more money thereon than was paid to defendants to take up said draft. Defendants hold that plaintiff lost nothing by the transaction and therefore there was no consideration for said defendants.

◆ ————— 1894. ————— ◆  
**THE DUHME COMPANY,**

ESTABLISHED 1844. INCORPORATED 1893.

**The Golden Anniversary.**

— CINCINNATI. —

R. H. GALBREATH, PRESIDENT.

**TRADE REJUVENATORS.**

That's what our monthly bargain sheets accomplish. If at all interested in the latest Novelties—in reduction of prices, if you expect to lead in the Jewelry Business in your town, send your name and address to

**OSKAMP, NOLTING & CO.,**  
 — Mammoth Wholesale Jewelers of America, —  
**Cor. 5th and Vine Sts., Cincinnati, Ohio.**

For Handy Information, For Valuable Reference, As a Money-Saving Device—Consult our Catalogue.



... THE ...

**"PASHA DIAMOND"**

WHITE STONE, GOLD JEWELRY.

Unequaled for Beauty, Style, Quality and Price.

WE ARE THE SOLE AGENTS.

Will Send Samples on Application.

**A. G. SCHWAB & BRO.,**

Importers of Diamonds and Wholesale Jewelers.

61 WEST FIFTH STREET,  
 CINCINNATI, O.

**PATENT FIBRE-FACED HAMMERS.**

5 oz. for Watchmakers.  
 10 oz. for Manufacturing Jewelers.  
 Price 50 Cents Each.

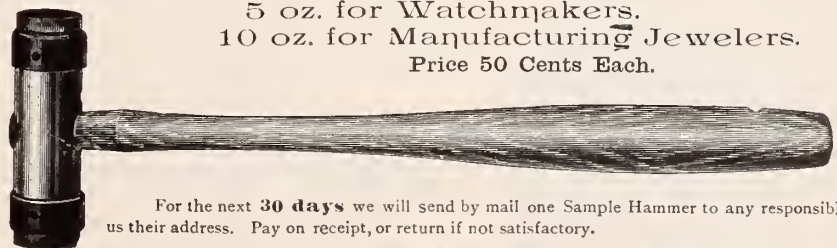

For the next 30 days we will send by mail one Sample Hammer to any responsible firm, giving us their address. Pay on receipt, or return if not satisfactory.

**W. W. OLIVER, Sole Manufacturer, - Buffalo, N. Y.**

Send for our No. 10 Catalogue.

JOSEPH JONAS.

JACOB DORST.

**JONAS, DORST & CO.,**

**Importers of Diamonds, Diamond Mountings, and Manufacturing Jewelers,  
169 & 171 RACE STREET, CINCINNATI, OHIO.**



**O. E. BELL & CO.,**

CINCINNATI, OHIO.

ARE HEADQUARTERS FOR

**SNAPS.**

Good ones. Write for latest circular. They can also give live jewelers exclusive control of finest line of Filled Cases made. Write them or the Bell Watch Case Co. for plans and specifications.

EST. 1870.



**DR. PETER HENRY,**  
SPECIALIST IN  
**WATCH • CASE • DISEASES**

Key Winders changed to Stem Winders.

Hunting Case changed to O. F.

English Cases changed to fit American movements

Can be cured at 53

Longworth St., Cincinnati, Ohio

**JOS. S. VOSS & SON, DIAMONDS, WATCHES AND JEWELRY,**

64 & 66 WEST 4th ST., CINCINNATI, O.

**ELGIN HOROLOGICAL SCHOOL,**  
THOROUGHLY PRACTICAL.  
COMPETENT INSTRUCTORS.  
Send for Prospectus.  
**ELGIN, ILL.**

WATCH CASE MAKERS AND REPAIRERS.  
**BOLSTAD MANUFACTURING AND PLATING CO.,**  
GOLD AND SILVER PLATERS.  
DESIGNING AND ENGRAVING.  
170 Madison Street, - - CHICAGO.

**PARSONS : SCHOOL**  
FOR  
**WATCHMAKERS,**  
**PEORIA, - - - ILL.**  
Send for Circular and Terms.  
**PARSONS & CO.**

**BENE, LINDENBERG & Co.,**  
**WHOLESALE JEWELERS,**

CINCINNATI, O.

• NO DULL TIMES WITH US. •

The beautiful and attractive goods we offer this season, prices considered, are great inducements, to even the smallest customer.

We will be pleased to send you a Selection Package.

JOS. NOTERMAN.

JOS. GOESLING.

**JOS. NOTERMAN & CO.,**

**IMPORTERS OF DIAMONDS AND MANUFACTURING JEWELERS,**

203 & 205 RACE STREET, CINCINNATI, OHIO.

Headquarters for Anything New and Salable in Diamond Mountings. | Ask for our Illustrated Catalogue of Diamond Mountings.

**GIBSON HOUSE,**

CINCINNATI, OHIO.

ABSOLUTELY FIRST-CLASS AMERICAN PLAN HOTEL.

\$3.00 PER DAY.

Extra Charge for Parlors and Rooms with Bath attached. The unequalled advantages in central location, liberal management, modern appointments, experienced service and perfect cuisine, have permanently established the Gibson House as The Most Popular First-Class Hotel in Cincinnati.

AMPLE VAULTS FOR THE PROTECTION OF VALUABLES.

**THE GIBSON HOUSE CO.,**

H. B. DUNBAR

President and Manager.



One Jeweler Only wanted in each City and Town, who can obtain, for a small order, the **EXCLUSIVE AGENCY** of our goods; also circulars, display cards, printed matter and local advertising.

**Our Bracelet** for the **CURE OF RHEUMATISM** is meeting with wonderful success on account of its actual value. It is at the same time a beautiful ornament, consisting of silver and zinc beads, highly polished, one-quarter of an inch in diameter; is perfectly flexible, exactly fitting the **wrist, forearm, ankle or leg,** a point highly in its favor. Write to us for particulars.

**WAREN & CO.,**

HADLYME, CONN.



**Final Action as to the Works of the Dulaney Clock Co.**

VALPARAISO, Ind., Jan. 30.—Another turn has been taken in the matter of the Dulaney clock works. On the 14th of last July the company assigned to Eli Norris. It was stated at the time that the liabilities were about \$35,000, and the assets \$25,000. It was thought by many that the assignment was the result of an attempted freeze-out on the part of Chicago stockholders. The business that had been done had appeared to be satisfactory.

Last Thursday afternoon the case was called by Judge Gillett, and the attorneys agreed that the compromise effected would be adhered to. The court then ordered Receiver Norris to execute a deed to William Coffine, of Chicago, for the real estate and machinery, valued at \$11,500; that Margaret Williams, of Chicago, who holds a note against said company for \$7,500 and 600 shares of stock, deliver the same to the receiver, and be thereupon released from liability, and further that she release all claim to notes and subscriptions to said company in possession of the Farmers' National Bank. It was also ordered that James M. McGill, of Chicago, give up the note for \$7,500 held by him and the 500 shares of stock and release all claims on notes, contracts, subscriptions, and money in the possession of said Farmers' National Bank, and that the said bank deliver the same to Receiver Norris.

It was further ordered by the court that the Dulaney Clock Co. by its officers make and deliver to William Coffine a quit claim deed to

the real estate and machinery, and that Dulaney Brothers and Wenk may have the property which they took out of said plant. Receiver Norris was also ordered to sell the stock of merchandise which is on hand, and which will be used to pay off the claims and also bring suit against all persons who took stock and have failed to pay for it.

**PRESIDENT WILLIAMS ARRESTED.**

CHICAGO, Ill., Feb. 1.—Benajah Williams, president of the bankrupt Dulaney Clock Co., has been arrested at Valparaiso and placed under \$2,000 bonds, on a grand jury indictment. The clock company was organized two years ago, and last July a receiver was appointed, owing to dissensions among the officers. Last week an amicable settlement was supposed to have been reached.

**Mrs. Mary A. Tanner Assigns.**

ZANESVILLE, O., Feb. 1.—Mrs. Mary A. Tanner, conducting the Abell jewelry store at 146 Main St., has made an assignment to Cary T. Marshall. The assignment included a farm of 120 acres in Falls township, on which there are incumbrances of \$3,400.

Chattel mortgages on the jewelry stock are on file in favor of F. A. Durban and W. H. Johnson for \$400; L. H. Goldsoll & Bros. for \$170; H. M. Smith & Co. for \$600, and Dr. J. L. Holden for \$500. The liabilities are placed at \$8,000, with assets of about the same amount.

**Wants to Dispose of Some of J. R. White Jewelry Co.'s Diamonds.**

ROCHESTER, N. Y., Feb. 2.—Attorney G. R. Losey applied to Justice Davy on Tuesday afternoon for an order permitting Arthur T. Hagen to dispose of a number of diamonds, valued at \$2,200, which he took as collateral security on a note for \$1,500, given by the J. R. White Jewelry Co., which is now in the hands of a receiver. The receiver is Chas. W. Gorton, and Mr. Gorton's counsel objected to the granting of such an order on the ground that there was no evidence before the court as to the value of the stones.

The attorney for the receiver told Justice Davy that if the diamonds were worth more than the amount due on the note, the surplus should be turned over to the receiver for the benefit of the creditors. The amount of the claims against the company was stated to be \$50,000. Justice Davy refused to grant the order, but told Mr. Losey he might obtain the affidavits of several jewelers as to the value of the diamonds and renew his application for the order upon presentation of the affidavits.

Chas. S. Stiff, Little Rock, Ark., will, on or about April 15, remove to the lower floor of the building now occupied by Wolf & Bro., at 3d and Main Sts. Mr. Stiff will handsomely remodel the building. He will also conduct a complete jewelry and bric-à-brac store at Main and 4th Sts., in addition to the new store.

**AMBERG & GOLDBERG, Successors to Amberg & Co. CINCINNATI, OHIO.**

A MODERN WHOLESALE JEWELRY HOUSE, ALIVE TO THE WANTS OF THE TRADE.

**TRY US.**

5th and **ELM STREETS.**

**MUEHLMATT, HEDGES & CO.,**

173 & 175 W. Fifth Street, Cincinnati, Ohio,

**GENERAL TOOL MAKERS AND DIE SINKERS**

and Manufacturers of Patent Specialties.

**GUSTAVE FOX & CO., 148 W. FOURTH ST., CINCINNATI, O.**

.. IMPORTERS OF DIAMONDS. . .

ARTISTIC DIAMOND SETTERS, (fine work a specialty.)

Makers of PATENTED ELK EMBLEMS.

The Antlers forming the letters B. P. O. E.

— SEND FOR SELECTION. —

**ALBERT BROS.,**

EXCLUSIVE WHOLESALE JEWELERS AND WATCHMAKERS,

ROOM 5, PIKE BUILDING,  
79 W. FOURTH STREET,

CINCINNATI, O.



AMERICAN RAILWAY SUPPLY CO.  
24 Park Place, NEW YORK.



## The Pulse of the West.

NOTES AND COMMENTS HERE AND THERE ON  
FIRMS AND THINGS.

**JOS. NOTERMAN & CO.**, Cincinnati, O., have outfitted their travelers with a splendid line of diamond novelties and other gems in fancy jewelry.

**AMBERG & GOLDBERG**, Cincinnati, O., are enlarging their stock, and increasing their price. The travelers are all out and have sent in fair orders for this season.

**JONAS, DORST & CO.**, Cincinnati, O., are headquarters for fine emblem designs. They have recently made several K. T. emblems mounted magnificently with diamonds and precious stones.

**CLEM. VOSS** is now representing Jos. Voss & Son, Cincinnati, O., in Ohio and Indiana. He made his first trip this year about two weeks ago, and returned after a successful tour of the territory.

**THE Aurora Silver Plate Mfg. Co.**, Aurora, Ill., have just completed for a Chicago house a large contract for goods to be distributed at the Mid-Winter Fair, San Francisco.

**MUEHLMATT, HEDGES & CO.**, Cincinnati, O., are manufacturers of the famous Monarch engraving block which is taking so well with the trade. They are working on other tools which they will soon bring out.

**CHELLEBUSH**, Cincinnati, O., has the finest stock of imported vases and ornaments in the west. The firm makes a specialty of fine bric-à-brac, and may be counted on as having just what you want for a handsome present.

**THE Brethauer Watch & Jewelry Co.**, 71 Washington St., Chicago, report an increased demand for high grade Dueber-Hampden watches. Mr. Brethauer thinks this is due to wearers of Dueber-Hampdens recommending them to prospective buyers.

**THE elegant catalogue of Elk jewelry of Gustave Fox & Co.**, Cincinnati, O., is stirring up patronage all over the country. There has never been issued such a varied and magnificent array of designs in a catalogue of these goods.

**ALBERT BROS.**, Cincinnati, O., have an elegant new stock to open the '94 campaign. They cleaned out their goods pretty well during the holidays. They are issuing a very fine calendar this year, which all their friends are anxious to have.

**BENE, LINDENBERG & CO.**, Cincinnati, O., will start out this season with an unusually attractive stock. They have been receiving new goods daily, and have decided to put such prices on them that will close them out quickly. August Neustedt will also go out for this firm.

**THIS is the golden year of the Duhme Co.**, Cincinnati, O., and they propose to make it a banner year of sales. After 50 years of successful trade they stand as one

of the most honored houses in the west. The name is a synonym for solidity and reliability.

**OSKAMP, NOLTING & CO.**, Cincinnati, O., are entering foreign markets. They have numerous orders from various points. They have imported a vast array of fine clocks in porcelain and have made runs on silver goods. They are headquarters for bargains.

**A. G. SCHWAB & BRO.**, Cincinnati, O., are the sole agents for the renowned Pasha diamonds and have placed them on the market with notable success. They have a high brilliancy and are mounted in exquisite designs and have proven ready sellers.

**A TOTAL enrollment of 18 students for the course of optics beginning March 6th at the Chicago Ophthalmic College, 607 W. Van Buren St., Chicago, makes a list greater than ever before so far in advance. Regular courses begin the first Tuesday of every alternate month beginning with January.**

**THOS. J. JUZEK & CO.**, Elgin, Ill., will shortly issue a new watchmakers' repair catalogue for the trade. The book will give prices for all branches of watch and watch case repairs, gold, silver and nickel plating, and spectacles and miscellaneous repairs. It is useful to every jeweler and will be sent upon request.

**ON inquiry as to the reason of a lot of artificial eyes in a steamer at the Geneva Optical Co.'s salesrooms, the information was given that all eyes returned as portions of selection packages sent to opticians were sterilized by superheated steam. This, it is understood, is not a common practice in the trade, but its health advantages are obvious.**

**THE new method of establishing optical departments in leading retail jewelry stores, as given by "Optician" in the advertising columns, has much to commend it. He places the department on a profitable basis and instructs the prospective head of the department in the proper fitting of glasses and in business methods. The idea gives promise of being largely availed of.**

**M. DREIFERS**, of the force of Jos. Mehmert, Cincinnati, O., has invented and patented and placed on the market a very useful tool called the hand remover, which is recommended to remove hands from the dials in one-tenth the usual time, and with no danger of losing hands or breaking the dial.

**HOMAN & CO.**, Cincinnati, O., have completed all their improvements and are now quite metropolitan in both factory and counting room. They have all the modern appliances, even to the long distance telephone which costs \$7.50 per minute to talk to New York friends. Their factory is running full time on staple goods. They are preparing to make a number of lines which will be introduced during the year.

**Do you play poker? If so, you know a royal straight flush cannot be beaten. The same is true of the five trump cards offered for the consideration of sellers of sweeps and old gold and silver by Goldsmith Bros., refiners and assayers, 63-65 Washington St., Chicago, viz.: (1) largest buyers of old gold and silver in the country; (2) purchase gold direct without refining; (3) largest plant and largest experience; (4) tests accurate and valuations correct; (5) give satisfaction. A trial shipment will convince one that they can save your money.**

**THE Elgin Horological School, at Elgin, Ill., dates its birth from October, 1887, since which time evening classes have been instructed in watchmaking. A year later day classes were established. Rows of benches filled with bright young men greet the eye as one enters the well lighted, well ventilated, hall-like room. J. L. Chapman and C. G. Carr, both practical watchmakers of years of experience, are the instructors, and each is well qualified by mental endowment to transmit his ideas to the students. Mr. Bentley, a thorough instructor in that line, has charge of the engraving department. The Elgin Horological School shows every evidence of success, and its efficient management is a guarantee of well grounded knowledge imparted to its graduates.**

**LAPP & FLERSHEM, "The busiest house in America," report their mail order trade for January fully equal to that of previous years. They are keeping their stock full in all departments, adding the latest novelties as soon as issued by the factories, and were never in better shape to supply the retail trade from a full assorted stock at right prices. A volume of 8,469 packages shipped in December on orders from legitimate jewelers, is proof of their right to the title of "the busiest house in America" and this grand total does not include goods sent by mail, goods sold in the city, or those sold to customers who made purchases at the store and took the goods with them. Their 864 page catalogue contains special information which will benefit every retailer.**

**"I don't believe in this gradual cutting of material prices," remarked Mr. Glickauf, of Glickauf & Newhouse, Chicago, when questioned as to watch material reductions. "It unsettles values and creates no larger demand than would otherwise be the case. This thing has been going on stealthily, and we are tired of it. If prices are to be cut they might as well be smashed completely, and that is what we are now doing all along the line." While Mr. Glickauf's statement as to cut prices unsettling values is correct, it is to be regretted that a smashing of prices should follow. The reductions made by manufacturers do not justify the firm in slashing away "all along the line." Their reduction in the price of the Acme lathe complete, and including foot wheel and countershaft, to \$25 is a case in point. While such a course will undoubtedly result in increased trade for Glickauf & Newhouse**



# No SHODDY! in our 8kt. RINGS.

ASSORTED IN TRAYS.

THEY ARE

## Plump 8kt. Through and Through.

GREAT AMOUNT OF RINGS

FOR LITTLE AMOUNT OF MONEY.

## Ask to see the New Combinations.

and be availed of largely by watchmakers throughout the country, it is not likely to meet with the approval of the jobbing trade or of tool dealers.

FEW firms have had showered upon them, in so short a space of time, such honors as has F. J. Essig, lapidist, 1222 Masonic Temple, Chicago. The firm do general lapidary work, but make a specialty of the Montana sapphire. In a handsome frame in the office, is displayed a certificate of award at the Georgia State Fair (Augusta Exposition) in which highest merit is accorded to the firm's Montana sapphires, both cut and in the rough; and in the Montana section of the World's Columbian Exposition, with the world as a competitor, they were awarded the blue ribbon on rough and cut sapphires and for a huge topaz of 550 karats, a perfect stone showing the perfection of the lapidist's art. Mr. Essig has large interests in the Montana sapphire beds near Helena, and has unusual opportunity for selection of colors. A proof of the advancing importance of the sapphire in combinations of differing colors and with other stones is seen in the fact that the firm's business has more than doubled during each of the past two years.

This is an age of labor saving inventions. To an engraver, where time counts for much, and the work stands perpetually as a monument to his skill, a saving of time and an aid to accuracy are two most important essentials. A most effective aid and a

great time-saver to engravers has just been placed on the market by Wm. H. Dietz, 117 Dearborn St., Chicago. This consists of rubber engravers' type in script and old English letters of a number of sizes, samples of which are herewith given:

*Minnie S. Foster*

By the aid of this type all tracing is done away with. The type are set in an improved holder and a colored impression stamped on the article to be engraved in clear cut script or old English.

*Sir Walter Scott.*

The outlines can readily be cut by anyone who can handle a graving tool and perfect and uniform letters are the result. Nineteenth of the time required for tracing can be saved. A catalogue of type will be sent on receipt of two cents postage by addressing Wm. H. Dietz, 117 Dearborn St., Chicago.

The stock of F. E. Burdick, 218 Asylum St., Hartford, is to be closed out at auction. Colonel P. B. Moore is the auctioneer.

Captain D. B. Hamilton and family, Waterbury, have not been able to secure a desirable passage on a first class steamer, and consequently they have for the present abandoned their contemplated European trip. They will go to Old Point Comfort for a few days.

# WE MAKE GOLD

LINK BUTTONS,

BROOCHES, CHARMS,

NECK LACES,

EYEGLASS CHAIN,

SCARF and STICK PINS,

STONE and BAND RINGS,

DROPS, STUDS, &c., &c.

## Waite, Thresher Company,

PROVIDENCE, R. I.



**FINE SMALL BRILLIANTS.**

**M. D. ROTHSCHILD,**

NEW YORK: 41 & 43 MAIDEN LANE

LONDON: 15 HOLBORN VIADUCT

PARIS: 58 RUE LAFFITTE.

**HENRY ABBOTT,**  
MANUFACTURER OF  
Stem-Winding Attachments  
FOR WATCHES,  
No. 2 Maiden Lane, NEW YORK.

**CAMPBELL-MEIGALF SILVER CO.**



176 Broadway, N. Y., Room 14. 66 Stewart St., Prov., R. I.  
4th Floor San Francisco, 8th Floor Room 1

**EMERALDS.**

**E. KIPLING,**

182 Broadway, New York.

ELEVATOR ENTRANCE, 2 JOHN ST.

**S. F. MYERS & CO.,**  
WHOLESALE JEWELERS,  
MYERS BUILDINGS, - - NEW YORK.  
1894 ISSUE, No. 38,  
**OUR ROYAL CATALOGUE**  
Illustrates all that is new, unique and desirable in  
everything that pertains to jewelry.  
Sent free to dealers who have not received it.  
TWENTY-TWO DEPARTMENTS.  
SEVEN DOUBLE FLOORS.  
Myers Buildings, 48-50 Maiden Lane, New York,  
33-35 Liberty St.,

FRENCH ENGLISH  
CLOCKS AND HALL CLOCKS AND  
MATERIALS. MATERIALS  
**CHAS. JACQUES CLOCK CO.,** 22 CORTLANDT ST., N. Y.

**L. LELONG & BRO.,**  
GOLD AND SILVER  
Refiners, Assayers and Sweep Smelters,  
SOUTHWEST CORNER HALSEY AND MARSHALL STREETS,  
**NEWARK, N. J.**  
SWEEPINGS A SPECIALTY.

**S. P. HOWARD,**  
Gold and Silver Assayer,  
Refiner and Sweep Smelter,  
33 MAIDEN LANE, NEW YORK.  
Smelting and Refining Works,  
28 & 30 Cumberland Street, Brooklyn, N. Y.  
Specialties: Sweepings, Gold, Silver and Platinum

**J. SCHAWEL & CO.,** 29 John St., N. Y.  
GOLD & SILVER REFINERS, ASSAYERS & SWEEP SMELTERS.  
STERLING SILVER, 925/1000 FINE IN SHEET AND WIRE.  
Soft Platinum, Sheet and Wire for Manufacturing Jewelers.

**Welded Chrome Steel and Iron**  
5 PLY  
  
FOR BUILDING  
Jewelers' Safes, Vaults, Etc.  
Positively BURGLAR PROOF, cannot be Cut, Sawed or Drilled.  
WE are the only manufacturers of Chrome Steel in the United States.  
None genuine unless stamped with our Trade Mark.  
**CHROME STEEL WORKS,**  
KENT AVENUE, KEAP AND HOOPER STREETS, BROOKLYN, N. Y.



**WM. BIRMINGHAM & CO.,**  
MANUFACTURERS OF  
All Kinds of Leather Spectacle and Eye Glass  
**CASES,**  
728 Arch Street, PHILADELPHIA, PA.  
**J. PRINCE,**  
Jewelry Auctioneer,  
At liberty from January 1st, 1894. Retail  
Jewelers only. Address,  
Rooms 9 & 10, 137 BROADWAY,  
N. Y. CITY.

**ALBERT LORSCH & Co.,**  
37 MAIDEN LANE, NEW YORK.  
Branch, 167 Weybosset Street, Providence, R. I.  
IMPORTERS OF DIAMONDS,  
Rose Diamonds, Rubies, Sapphires, Emeralds, Opals, Moonstones,  
Fancy and Imitation Stones, Novelties.  
SOLE OWNERS AND IMPORTERS OF *The Sumatra Gem,* REG'D. UNEQUALLED IN BRILLIANCY AND HARDNESS  
HIGHEST AWARD AT THE COLUMBIAN EXPOSITION, CHICAGO, 1893.

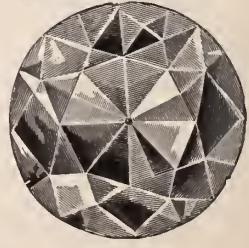
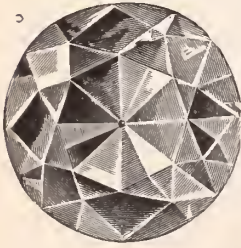

1869=1894=Twenty-five Years, Oldest, Best, Brightest, Newest, =The Jewelers' Circular.





Copyright by THE JEWELERS' CIRCULAR PUB. CO.

189 Broadway, New York.

Entered at the Post Office in N. Y. as second-class matter.

VOL. XXVIII.

NEW YORK, WEDNESDAY, FEBRUARY 14, 1894.

NO. 2

## ANCIENT STATUES IN THE PRECIOUS METALS.

THERE is reason to believe that almost at the very dawn of civilization, human figures were introduced by goldsmiths and silversmiths in the decorations of their works. It is almost certain also that some statues and statuettes of precious metals were made, at all times and in all civilized countries. If ancient bronze and marble statues only have been preserved, it is because they had no intrinsic value.

In ancient Egypt, according to Maspero's book on *Archéologie Egyptienne*, bronze statues were covered with sheets of hammer-hardened gold. These sheets were applied on bronze by means of an ammoniacal mordant. Statues of gods of massive gold, silver, or electrum (asimon), pale gold containing from 20 to 60 per cent. of silver, were made during the periods of the eighteenth and nineteenth dynasties. Many were only a few centimeters high, but some attained more than three cubits in height. Besides statues entirely of gold and silver, there were some partly in gold and partly in silver; also some in the style which the Greeks called chryselephantine, being in gold associated with carved ivory, ebony and precious stones. A few tiny statuettes of gold, being votive offerings, have been found in unearthing ruins of temples. Some, being amulets, were found on mummies; while others, that were domestic deities, have been discovered among ruins of private houses.

The only statuettes in precious metals belonging to the best period which have been preserved, are the Ptah, and the Ammon of Queen Ahhotpon, and another Ammon in gold, exhibited at the Boulg Museum.

Wealthy Egyptians possessed among a great variety of articles in gold and silver, some very artistic flower vases of large size. A curious one consisted of a cup with

curved outlines, the handles of which were adorned at the base with a papyrus bud. The stand, formed of papyrus stalks with foliage at the top spreading on the lower part of



PHIDIAS' STATUE OF MINERVA OF THE PARTHENON.

the cup, was supported by two statuettes, of Asiatic slaves back to back and wide apart, each holding a handle with one hand and the base of the stand with the other. The ensem-

ble was in the highest sense symmetrical.

According to ancient records, the Greeks learnt the art of working precious metals from the Lydians and Phrygians. At Samos there lived a family of eminent goldsmiths: first Rhœcus, then his son Telecles, and his grandson Theodorus. The latter, who lived seven centuries B. C., was the favorite goldsmith of King Crœsus. Herodotus tells us that among the innumerable and magnificent presents offered to the oracle of the temple of Delphos by the wealthy and ostentatious king was a gold statue three cubits high.

We know that the great artists of Greece employed for their works all kinds of substances. They made statues of stone, marble, bronze, silver, gold, etc. Under the name of chryselephantine statuary, they produced works made of ivory, gold and silver together with various alloys of these metals. One of the most remarkable specimens of this art was the Minerva of the Parthenon, which Phidias made in the year 448 B. C. Pausanias and Pliny have given a full description of it. This statue, twenty-six cubits high (about ten meters), was in a standing attitude, covered with the ægis, and clad with a long robe falling to her feet. Her left hand held a spear, and in her right hand stood a statuette of Victory, nearly four cubits high, holding aloof a laurel wreath. The helmet of the goddess was surmounted by a sphinx, emblematic of divine intelligence. On the lateral parts of the helmet were two griffins, and at the base, just above the forehead, eight horses placed side by side in a galloping attitude. The draperies were of gold the bare parts of the body in ivory, while the eyes were precious stones (iris). The convex part of the shield, of gold, was adorned with a chased scene showing the fight of the



# DEITSCH BROS.,

7 EAST 17TH ST., NEW YORK.

## LEATHER GOODS.

EBONY AND SILVER COMBINATIONS.

ORIGINATORS AND MAKERS OF

NOVELTIES IN LEATHER AND STERLING SILVER COMBINATIONS.



\*\*\*\*\*

**CROSS & BEGUELIN,**

17 MAIDEN LANE, NEW YORK,

ALL GRADES OF SWISS AND AMERICAN WATCHES, DIAMONDS, GOLD AND ROLLED PLATE JEWELRY, OPERA AND FIELD GLASSES, TOOLS AND MATERIAL.

SOLE AGENTS FOR THE **Rockford Watch Co. MATERIAL.** MANUFACTURERS OF THE **Centennial Watches.**

SEND FOR OUR WATCH MATERIAL AND TOOL PRICE LIST FOR 1894.

\*\*\*\*\*

### AMERICAN SYNDICATE OF Jewelers' Auctioneers.

ESTABLISHED for the sole purpose of conducting sales for established Jewelers in the United States, Canada and Mexico. We do not sacrifice your goods. We take no sales on a percentage. Our terms are strictly one-half the profits realized on all goods sold. We guarantee you against any loss. We pay all our own expenses; we don't ask you to pay one cent of expense on our account. We buy stocks complete as well as sell them. If your stock is small, or your assortment is not complete, we will furnish from one to ten thousand dollars worth of any kind of stock you may need and in which you need not invest one penny. Don't make any arrangements with others until you read our pamphlet which we will send you free, giving you full particulars of our style of doing business, and the liberal offers we make to Jewelers. We don't care how small your stock is, we will furnish all the stock you need to make a successful sale. We challenge the world for any fairer or more liberal propositions than we make Jewelers. Don't fail to send us your address, and we will send you our business pamphlet, which gives you full explanations as to our terms and style of doing business. Address,

### "THE BEST BUTTON MADE."

THE KREMENTZ

IN GOLD IN ROLLED PLATE

FROM FROM

**KREMENTZ & CO.** ONE PIECE **ALL JOBBERS**

AND ALL JOBBERS.



**COLLAR BUTTON.**

IS THE ORIGINAL ONE PIECE BUTTON. IS STILL THE BEST AND STILL UNSURPASSED.

### AMERICAN SYNDICATE OF JEWELERS' AUCTIONEERS.

Offices: } 20 WEST 14th STREET, NEW YORK. }  
611 PENN AVE., WASHINGTON, D. C.

Sold by all wholesale dealers at manufacturer's price.

**A. N. CLARK,** PLAINVILLE, CONN.

Manufacturer of the Celebrated **LOOP WATCH KEY.**

The Best for the Price in the World. CROSBY'S JEWELING TOOLS IMPROVED.

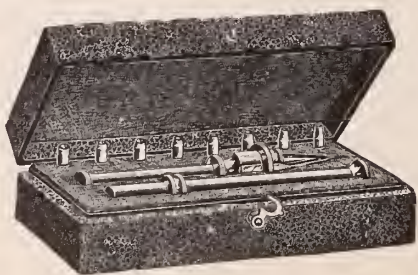

ESTABLISHED 1837.

**GEO. O. STREET & SONS.**

MAKERS OF

Fine Rings, Locketts, Seals, Sleeve Buttons and Links.

15 John Street, NEW YORK.

JACOT & SON IMPORTERS AND MANUFACTURERS OF

**MUSICAL BOXES**

298 BROADWAY. NEW YORK



Will quote royalty or price for the manufacturing of articles of real worth.



THE OLD AND RELIABLE

# STAR ★ BRAND

## Electro Silver Plated Flatware.

COLUMBIA.

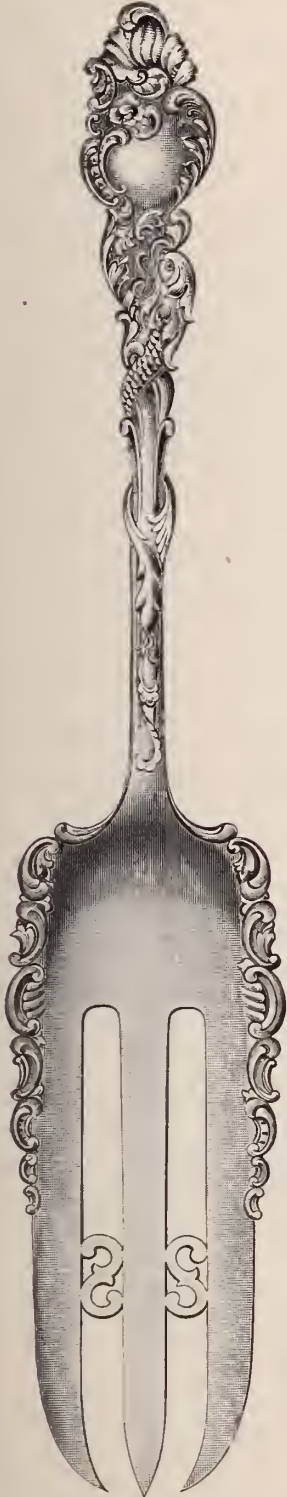

COLD MEAT SERVER

SAVOY.



FRUIT FORK

SAVOY.



BOULLON SPOON,

COLUMBIA.



BUTTER PICK.

COLUMBIA.



INDIVIDUAL SALAD FORK. |

STAMPED

### ★ ROGERS & BRO., A=1.

HAS STOOD THE TEST FOR FIFTY YEARS.

MANUFACTURED BY

## ROGERS & BROTHER,

FOR SALE BY ALL FIRST-CLASS

JOBBER AND JEWELERS.

Waterbury, Conn.,

SEND FOR NEW CATALOGUE NOW READY.

16 Cortlandt St., N. Y.

Athenians against the Amazons; the other side showed the fight of the giants against the gods. Around the high soles of the shoes was chased the fight of the Lapithes against the centaurs. The pedestal exhibited various scenes, one of which related to the birth of Pandora. The cost of this statue was equal to more than \$800,000. It was so made that all the gold could at any time, be taken off and weighed. Owing to this contrivance, Phidias was enabled to oppose accusations which his enemies brought against him. He could prove, without injuring his work, that he had employed all the gold which had been given him for the purpose.

Phidias' Minerva, as it is believed to have been, was reproduced on a smaller scale, by Simart, at the order of Duke de Luynes. It was one of the chief attractions of the Paris Exhibition in 1855, and now occupies a prominent place in the duke's collection at the Château de Dampierre. It required eight years to gather all necessary documents and to achieve this remarkable work, which is reproduced in this article. From two elephants' tusks, each five feet long, were carved the face, the neck, the arms, the feet, the Medusean mask in the center of the ægis which covers the breast of the goddess, and the bare bust of the statuette of Victory. All the other parts are of silver excepting the spear and the shield, which are in bronze. The helmet, the shield, the spear and the snake at the right hand side

of the statue, were obtained by casting. All the ornaments on the robe and ægis are chased. The gold bath required for gilding the robe cost 12,000 francs. The whole work has cost 250,000 francs.

We gather also from ancient records that Phidias made of gold and ivory an Olympian Jupiter of a still larger size than his Minerva. This statue, 18 meters high, was seated on a throne incrusting with gold, ebony, ivory and precious stones.

(To be Continued.)

#### The Death of George Lampman.

GREENSBORO, N. C., Feb. 8.—George Lampman, formerly of Ironton, O., but for eight years past in the jewelry business in this place, died suddenly of heart failure on Monday, Jan. 29th, at the age of 57 years.

Mr. Lampman was well-known as a straightforward business man, and was highly respected in the community in which he lived. His death is much regretted by a wide circle of friends. He leaves a widow and two daughters in comfortable circumstances.

The funeral services were conducted by the Masonic Lodge, of which he was a member, a mounted company of Knight Templars attending as an escort.

Charles Rosen, watchmaker, of Albany, N. Y., was attacked by highwaymen while on his way home one night last week. They went through his pockets and secured \$195.

#### Imports and Exports for December, 1893, and the Preceding Twelve Months.

WASHINGTON, D. C., Feb. 8.—The summary statement of imports and exports for the month ending Dec. 31, 1893, and for the twelve months ending the same date, compared with the corresponding periods of 1892, has been issued and contains the following relative to the jewelry trade:

IMPORTS.—Diamonds and other precious stones, rough or uncut, including glaziers' and engravers' diamonds not set, and jewels to be used in the manufacture of watches: Month of December, 1893, \$28,988 against \$112,380 same month of 1892, and \$40,491 in November; clocks and parts of, December 1893, \$4,453 against \$16,686 same month of 1892, and \$10,176 in November; watches and parts of, and watch materials and movements, December, 1893, \$92,286 against \$140,254 same month of 1892, and \$110,891 in November; jewelry and manufactures of gold and silver, December, 1893, \$18,484 against \$49,362 same month last year, and \$49,619 in November; precious stones and imitations of, not set, December, 1893, \$254,752 against \$773,387 same month last year, and \$180,311 in November; platinum unmanufactured, December, 1893, \$31,109 against \$39,210 same month last year, and \$34,883 in November.

EXPORTS OF DOMESTIC MERCHANDISE.—Clocks and parts of, December, 1893, \$72,355 against \$113,222 same month last year, and

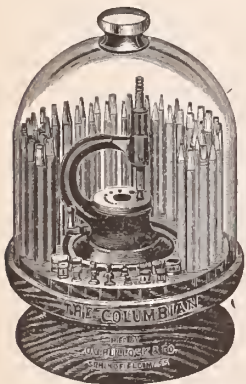

#### OUR OWN ★ "COLUMBIAN"

Fifty Punch Staking Tool, LEADS ALL OTHERS in STYLE, FINISH and ACCURACY. Hundreds of practical Watch Makers pronounce it the BEST.

Nickel frame, mahogany base, extra fine tempered steel punches and stumps.

—→ FULLY WARRANTED. ←—

For full description send five cents in stamps, with business card, for New Catalogue of OVER ONE THOUSAND varieties of fine Watch and Bench Tools of OUR OWN MAKE, many entirely new.

O. W. BULLOCK & CO.,  
SPRINGFIELD, MASS.

#### VICTOR. ☉ ☉

SIMPLEST FEED. ALWAYS THE SAME.  
GUARANTEED FOR ONE YEAR.

#### THE VICTOR FOUNTAIN PEN

(Pat. Feb. 4, 1890.)

THE BOSTON PEN CO.,

N. C. Whitaker & Co., Proprietors.

363 Washington Street, Boston, Mass.,

Manufacturers of finest quality

TORTOISE : SHELL : AND : HORN : GOODS  
in every variety. Also Aluminum Hair Pins.

Send for illustrated Pen Price List No. 1.

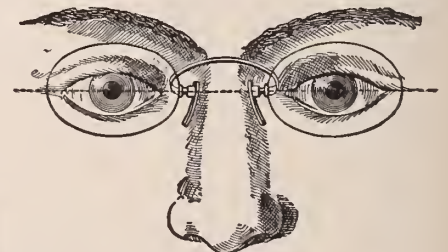

Patented Feb. 9, 1892.

#### THE W. B. & E.

Marvel Tilting Spring Eyeglass in Gold,  
Steel, and Frameless.

JULES LAURENCOT & CO.,

49 MAIDEN LANE, NEW YORK.

Sole Agents in the United States and Canada.



*Pairpoint's*  
THE

MFG. COMPANY,

Gold and Silver Plate. **FACTORIES:**  
New Bedford,  
Mass.

HEADQUARTERS FOR  
RICH CUT GLASS.  
COLONIAL,  
ROYAL FLEMISH,  
CROWN MILANO.  
Decorated Art Glass.

MAKERS OF

Hollow and  
"1880" Flat Ware.



No. 6300. ORANGE HOLDER.



No. 2697. EMBOSSED CANDLESTICK.

SALESROOMS:

NEW YORK, - - 20 Maiden Lane.  
CHICAGO, - - 224 Wabash Avenue.  
SAN FRANCISCO, 220 Sutter Street.



No. 6301. ORANGE HOLDER.

**A Plain Business Proposition.**

Our papers are so put up as to particularly meet the requirements of the Jewelry Trade.

THEY ARE

"NEATLY BOXED,"

THEY ARE

"CHOICE,"

THEY ARE

"COMPACT,"

and hence require no large space for display. A good salesman can sell writing paper as easily as watches or rings. There is a good profit and a quick sale. No dead stock. The outlay is small and the result sure. Try it.

We sell to the legitimate Jewelry and Stationery Trade only.



CHOICE PAPERS

MAKERS OF

FINE STATIONERY

For Correspondence, Wedding and Business Use, Handsomely boxed, specially suited to the Jewelry Trade.

18 MURRAY STREET,

NEW YORK.

# R. WALLACE & SONS MFG. CO.

SILVERSMITHS

Trade Mark.



R. W. & S.  
Sterling.

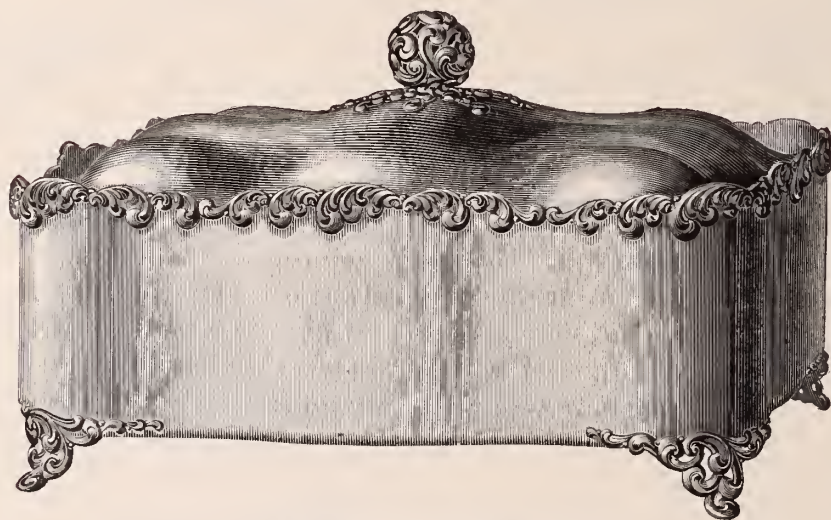

WAVERLEY SARDINE BOX.

Manufactories and  
Main Office,

WALLINGFORD, - - CONN.

BRANCHES :

NEW YORK  
3 PARK PLACE.

SAN FRANCISCO,  
120 SUTTER STREET.

CHICAGO  
86 WABASH AVENUE.



\$87,207 in November; watches and parts of December, 1893, \$21,278 against \$15,333 same month last year, and \$37,248 in November; jewelry and manufactures of gold and silver, December, 1893, \$71,869 against \$70,838 same month last year, and \$76,543 in November; plated ware, December, 1893, \$25,835 against \$30,009 same month last year, and \$37,812 in November.

IMPORTS, for twelve months ending Dec. 31, 1893.—Diamonds and other precious stones, rough and uncut, etc., \$802,075 against \$1,022,869 in 1892; clocks and parts of, etc., \$166,724 against \$229,998 in 1892; watches and parts of, etc., \$1,465,074 against \$1,625,650 in 1892; jewelry and manufactures of gold and silver, \$696,185 against \$494,530 in 1892; precious stones and imitations of, not set, \$10,022,371 against \$13,427,774 in 1892; platinum, unmanufactured, \$538,478 against \$564,819 in 1892.

EXPORTS OF DOMESTIC MECHANISE, for twelve months ending Dec. 31.—Clocks and parts of, \$919,965 against \$948,616 in 1892; watches and parts of, \$385,194 against \$167,942 in 1892; jewelry and manufactures of gold and silver, \$1,008,544 against \$686,567 in 1892; plated ware, \$343,492 against \$316,404 in 1892.

EXPORTS OF FOREIGN MERCHANDISE.—Diamonds and other precious stones, etc., December, 1893, nothing against nothing and \$355 against \$1,281 for twelve months; clocks and parts of, December, 1893, nothing against \$1,000 in December, 1892, and \$684 against \$1,037 for twelve months; watches and parts of, etc., December, 1893, \$175 against nothing in December, 1892, and \$619 against \$290 in twelve months; jewelry and manufactures of gold and silver, December, 1893, \$501 against \$1,407 and \$17,308 against \$69,314 for twelve months; precious stones, etc., December, 1893, \$309,977 against \$1,561 in December, 1892, and \$311,305 against \$5,956 for twelve months.

The comparative summary of values of merchandise imported and exported during twelve months ending December 31, from 1888 to 1893 inclusive, shows the following anent the jewelry and kindred lines; Average of the preceding five periods, imports, clocks and watches and parts of, \$2,082,866 twelve months ending December 31, 1893, \$1,631,798; imports, jewelry, manufactures of gold and silver and precious stones, average of the five preceding periods \$13,117,043, twelve months ending December 31, 1893, \$10,718,556; exports, clocks and watches, average of the five preceding periods, \$1,442,547, twelve months ending December 31, 1893, \$1,305,159.

**The Creditors of A. H. Peacock.**

DALLAS, Tex., Feb. 6.—The deed of trust filed by A. H. Peacock, doing a jewelry business at 221 Elm St., in which W. H. Howell is named as trustee, as stated in last week's CIRCULAR, is for the benefit of the following named creditors to share alike: J. A. Norton & Son, \$15.60; Mosler Safe

**B. & M. KNOWLES & CO.**  
 MAKERS OF  
**STERLING SILVER WARE**  
 FACTORY: PROVIDENCE R.I. SALESROOM: 260 BROADWAY N.Y.

**IRONS & RUSSELL,**  
 (SUCCESSORS TO CHARLES F. IRONS.)  
 MANUFACTURERS OF  
**SOLID GOLD EMBLEMS ROLL PLATE**  
 PINS, CHARMS AND SOLID GOLD RINGS.  
 102 Friendship Street, - - Providence, R. I.

**THE BOWDEN SEAMLESS RING**  
 IS MADE ONLY BY  
**J. B. BOWDEN & Co.,**  
 Makers of Finger Rings of every Description.  
**COR. BROADWAY & JOHN STREET,**  
 NEW YORK.

**S. C. JACKSON,** 180 BROADWAY, NEW YORK.  
 MANUFACTURER OF  
 Fine \* Cases \* for \* Jewelry, \* Silverware, \* Etc.  
 ALSO SHOW CASE TRAYS AND FANCY HARD WOOD WORK  
 Samples sent on application. Estimates furnished.

**A.J. COMRIE,**  
**AUCTIONEER**  
 182 BROADWAY  
 NEW YORK

SPECIAL SALESMAN OF  
**WATCHES, DIAMONDS,**  
 Bric-a-Brac  
 and Art Goods  
 FOR  
**Established Jewelers.**  
 WRITE FOR PARTICULARS.  
 Communications Strictly Confidential.  
 References given in all parts of the United States from Retailers and Jobbers



# Nothing Better. —————

**5** AWARDS and DIPLOMAS  
IN FLATWARE ONLY.

**CHARACTERIZED BY**

- 1st. Most marked process by the use of silver inlaid.
- 2d. Superior excellence, insuring a durability hitherto unknown.
- 3d. Highest grades of materials.
- 4th. Finest Plating, workmanship and finish.
- 5th. Artistic Display.

**THE HOLMES & EDWARDS SILVER CO.,**  
BRIDGEPORT, CONN.

## DIAMOND EXCHANGE BUILDING.



In the new fire proof,  
ten story

Diamond Exchange Building,

14 Maiden Lane.

### OFFICES

of most modern construction,  
with abundance of light and  
air, rapid elevator, mail chute,  
steam heat, gas and electric  
light, exposed sanitary plumbing,  
oak cabinet trim, unique  
plate glass partition and quar-  
tered oak floors. at rentals from

**\$900.00**

Per Annum up.

Specially adapted for the Dia-  
mond and Jewelry Trade.  
Possession on or before May  
1st, next.

For further particulars apply to

**E. A. Cruikshank & Co.,**

176 Broadway, N. Y.

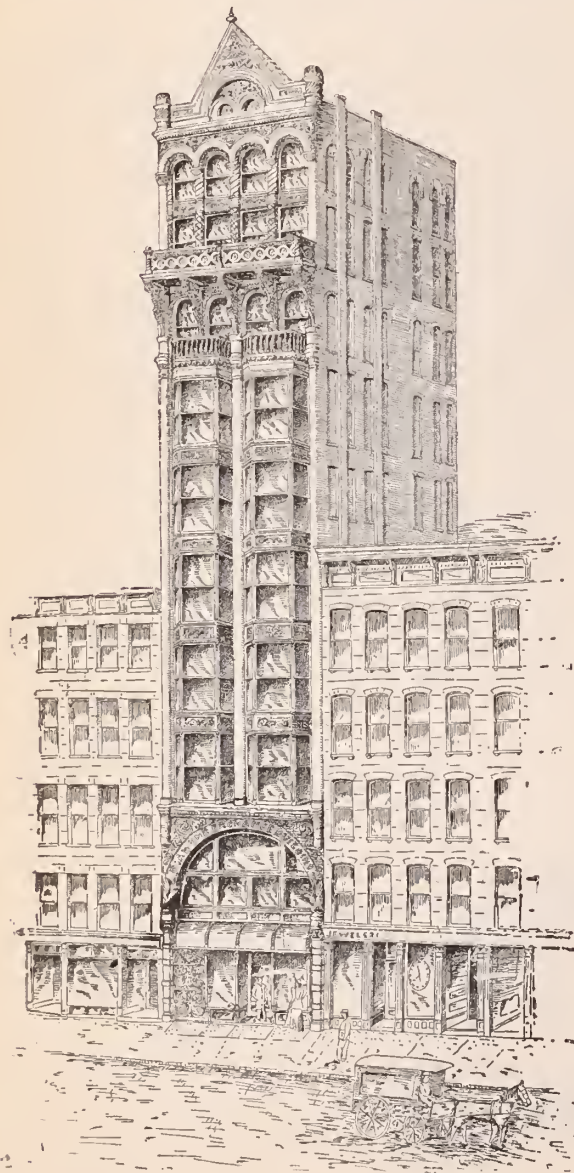

# Easter Novelty. —————

BOOK MARKERS WITH FOUR (4)  
SOLID SILVER TOKENS, MOUNTED  
ON CARD BOARD WITH THE WORDS

**"EASTER GREETING"**  
STAMPED WITH STEEL DIE AT  
TOP.

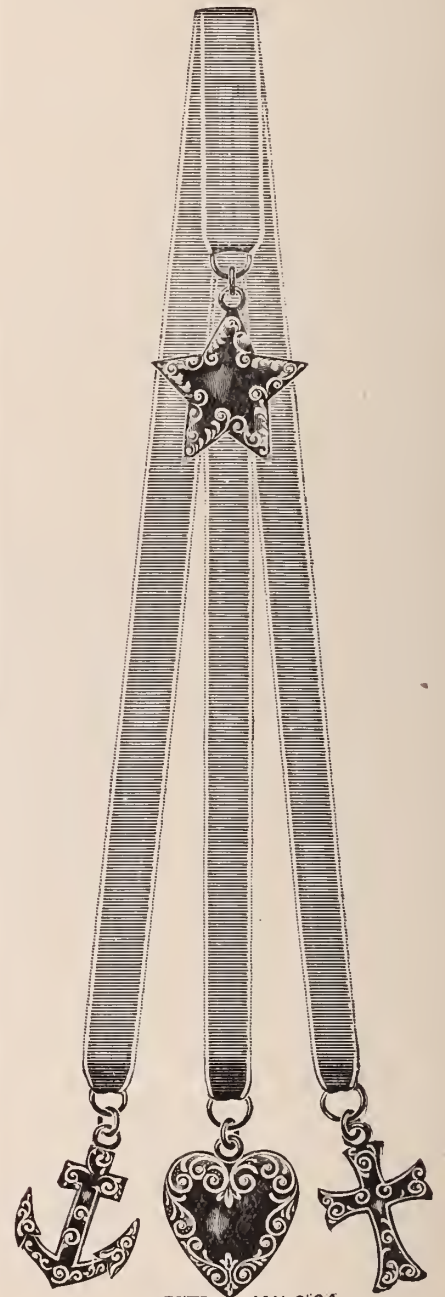

ESTD. JAN. 6 '94.

A QUICK SELLING AND POPULAR  
NOVELTY.

SEND FOR SAMPLES.

**QUEEN & CO.,**  
1010 Chestnut Street,  
PHILADELPHIA.



Co., \$132; M. A. Mead & Co., \$221.80; Kent & Stanley Co., \$176.25; H. M. Ryan, New York, \$135; Aikin, Lambert & Co., \$87.95; John W. Sherwood, \$252; Rockford Watch Co., Rockford, Ill., \$85; Adolph Goldsmith & Son, \$263.80; Keller, Ettinger & Fink, \$159.25; Spencer Optical Mfg. Co., \$164; Van Houten Bros., \$150; Simpson, Hall, Miller & Co., \$357.76; Seth Thomas Clock Co., \$199.40; O. E. Bell & Co., \$173.85; Jacob Strauss & Sons, \$155; Edwards & Sloane Jewelry Co., \$115.52; Hayden W. Wheeler & Co., \$225.50; Whiting Mfg. Co., \$125; Dueber Watch Case Mfg. Co., \$110.25; Hampden Watch Co., \$131.40; Julius King Optical Co., \$229.05; Oppenheimer Bros. & Veith, \$409.19; Fink, Bodenheimer & Co., \$321.60; Waterbury Watch Co., \$11; L. Krower & Co., \$65.50; A. R. Brooks Jewelry Co., \$61; A. M. Belo & Co., Dallas, \$232. Total, \$5,019.57.

**Annual Meeting of the Hampden Watch Co.**

SPRINGFIELD, Mass., Feb. 17.—The Hampden Watch Co. held their annual meeting in this city yesterday. The old board of directors and officers were re-elected as follows: Directors, James D. Safford and Geo. R. Bond, of this city, and John C. Dueber, Joseph C. Dueber and W. A. Moore, of Canton, O. The directors organized by electing these officers: President and treasurer, John C. Dueber; secretary, W. A. Moore; transfer clerk, Geo. R. Bond.

President Dueber reported a most successful year in business and a very bright prospect for the future. The reports from the different committees were gratifying, showing that in spite of the business depression the company's indebtedness had been largely reduced during the year.

**Edward Moulton's Offer Confirmed by the Court.**

WORCESTER, Mass., Feb. 9.—The adjourned meeting of the creditors of Edward Moulton, 399 Main St., was held in Judge Forbes' Court, Tuesday, Feb. 6th. The claims were approved and the offer of composition of 30 cents on the dollar was confirmed by the court.

The liabilities amount to about \$35,000.

**The Jewelers' Security Alliance.**

The regular monthly meeting of the executive committee was held at the Alliance office on the 9th inst. There were present: H. H. Butts, chairman; A. K. Sloan, president; David Untermeyer, vice-president; Bernard Karsch, treasurer; Messrs. White, Kroeber, Wood and Abbott and Geo. H. Hodenpyl, secretary.

The following were admitted to membership: Chas. A. Thomas, Athol, Mass.; Jacobson Bros., 16 Maiden Lane, New York; Palais Royal, 103 N. 8th St., Philadelphia, Pa.; Forsythe & Hoffman, 18th and Market Sts., Philadelphia, Pa.; A. W. Cornelius, Asbury Park, N. J.; Edmund Spencer, Hudson, N. Y.

**Traveler H. C. Barnum Has an Anxious Time With His Trunk.**

SPRINGFIELD, Mass., Feb. 9.—H. C. Barnum, traveling representative for Shafer & Douglas, New York, was yesterday the victim of one of the most daring robberies ever perpetrated in this country, but thanks to the activity of the police the thief did not realize much by his venture.

Mr. Barnum was in Northampton Wednesday and came to this city that evening intending to visit the local jewelers yesterday. He checked his trunk through and left it in the baggage room at the depot. Late in the evening he visited the baggage room and examined the check on the trunk to assure himself that everything was all right and then he retired to his hotel. About eight o'clock yesterday morning he went for the trunk but it was not to be found. He finally learned that one of the expressmen at the depot had carried it to the Hotel Glendower, and he at once followed it. When he reached the hotel he went to the room designated by the porter and was non-plussed to find the trunk broken open and almost its entire contents of rings, valued at from \$12,000 to \$15,000 missing. The police were at once notified and the search began.

It was found that a man named G. H. Boyd, of Boston, or at least so signing himself on the hotel register, had occupied the room the night before, and it was he who had taken the trunk from the depot and brought it to the hotel. It is the opinion of the police that Boyd had been following Mr. Barnum for days and when in Northampton had stolen a set of checks from the baggage room. He came here, stopped at the Glendower Wednesday night and early yesterday morning went to the depot and taking the regular check from the trunk substituted the one he had stolen. Then he approached the baggage master and asked to have the trunk put on the train for Hartford which was due to leave in about ten minutes. The official told him that it would be impossible to do this and Boyd went out and engaged the expressman to take the trunk to the hotel. He purchased a hammer and rifled the trunk, taking one of the leather cases and dumping all of the jewelry into it. Then he went out, had breakfast, later going to the American express office to ship the case to Worcester, although it is believed that he transferred a large part of the jewelry to the grip which he carried, and sent the case on to Worcester to throw the officers off the scent.

In the meantime the firm had been notified and the Jewelers' Protective Union telegraphed the local police to spare no expense in ferreting out the thief. They also sent Pinkerton detectives from New York and Boston, but at the time of writing Boyd had not been captured.

THE MOST VALUABLE PART OF THE PLUNDER RECOVERED.

WORCESTER, Mass., Feb. 9.—The case stolen at Springfield by Boyd from H. C. Barnum,

**Damascus**

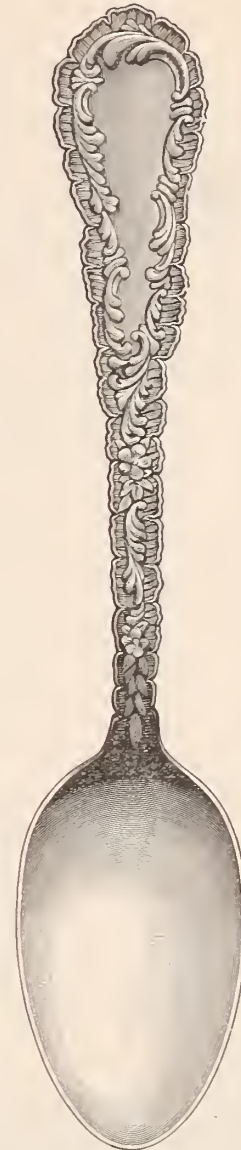

DAMASCUS TEA.

MADE IN A FULL LINE

The Best Pattern of the Season.

READY THIS SEASON.

A GENERAL LINE OF

Hollow Ware.

New Ideas Constantly.



**F. M. Whiting & Co.,**

MANUFACTURERS OF STERLING SILVERWARE,

Novelties in Silver Jewelry.

NORTH ATTLEBORO, - - MASS.



**M. L. READ & CO.,**

161 DORRANCE ST., PROVIDENCE, R. I.

THE Old Reliable House

FOR STICK PINS AND WHITE STONE GOODS.



traveler for Shafer & Douglas, New York, was expressed by the thief to this city consigned to one T. G. Davis, at a fictitious address. For eight hours the police were closeted in the American Express Co.'s office waiting for "Davis" to claim the package, but he did not in put an appearance, and Mr. Barnum will probably get his valuables to-day. The case contained the most valuable lot of samples stolen. It is believed the thief put some of the goods in his pocket in case he would be unable to get possession of the case without being arrested.

THE THIEF SUPPOSED TO BE CAPTURED.

SPRINGFIELD, Mass., Feb. 11.—The police have made several arrests and think that they have captured the thief who rifled H. C. Barnum's trunk. The star of the coterie and the one who is suspected of doing the job is Wm. J. Cummings, of Boston, who was arrested at "The Hub," July 11th last, for similar tricks in the baggage room of the Old Colony Railroad. Since then, it is said that he has been acting as a decoy for the Boston police, and one of the Boston police captains claims that Cummings was in his station house at 10 o'clock Thursday morning, which, if true, establishes a perfect alibi for him. But Cummings' description tallies exactly with that of the man who registered at the Hotel Glendower and who visited the baggage room and later brought the trunk to the hotel, as well as with the man who had been following Mr. Barnum for several days.

The other men arrested were Andrew J. Andrews, as he is now known, and a New Yorker named Wm. Virtue, alias H. C.

Boyd. Both of the latter are graduates of Elmira Penitentiary, but the former has been living in this city for some time under an assumed name. It is known that Virtue has been visiting Andrews lately but the latter claims that he left for New York on Wednesday.

The Firm of Cross & Beguelin Incorporated.

Cross & Beguelin, general jobbers of watches, jewelry, tools, etc., and importers of watches, at 17 Maiden Lane, New York, were incorporated Thursday with a capital of \$300,000. The directors are: Alfred F. Cross, Henry Cottier, Alfred Baillo, Wm. T. Cross and Ferdinand L. Cross. Alfred F. Cross is president and treasurer, and Henry Cottier, secretary of the concern.

Cross & Beguelin have been in business since 1864. The partners were Alfred F. Cross and Henry E. Beguelin. The latter died Aug. 20, 1892, and Mr. Cross continued the business. Alfred F. Cross stated to a CIRCULAR reporter that there would be no change whatsoever in the business of the firm. It had been incorporated, he said, merely to facilitate matters in case of his death so that the business could be continued without any difficulties. The firm name has been in existence 31 years, and Mr. Cross by the incorporation, had assured its continuance for 50 years longer.

Of the directors, Henry Cottier is the present cashier, and Alfred Baillo, who is a nephew of Mrs. Beguelin, has been connected with the firm for several years. Wm. T. and Ferdinand L. Cross are sons of Alfred F. Cross. They have also been connected with the business.

Besides watches and jewelry the firm also handle tools, materials, plated ware and diamonds. They have a factory in America and in Chaux-de-Fonds, Switzerland.

"Red Pepper" Throwers Rob a Springfield Jeweler.

SPRINGFIELD, Mass., Feb. 11.—H. J. Davison was the victim of the "red pepper" trick last night and was robbed of diamonds valued at \$300. It happened shortly after 6 o'clock when Mr. Davison was alone in the store. A well dressed young man entered and asked to be shown some diamond rings and studs. Mr. Davison placed several on the counter and the fellow carefully examined them. During the operation another fellow entered and as the proprietor looked up, he waved him aside and said: "Wait on this gentleman first, I will wait."

After a while stranger No. 1 said: "I guess I'll take these," at the same time scooping up the jewels with his hands. Mr. Davison looked up quickly and as he did so the second man threw a handful of red pepper at him. Fortunately Mr. Davison had his glasses on and did not receive the full contents in the eyes, but got enough to temporarily blind him and cause him a great deal of pain. The two men ran out, followed by Mr. Davison who called a policeman from the beat near the store, but the thieves, although seen by the officer, managed to escape. One was tall with a light complexion and moustache, while the other was dark with a smooth face. Both wore dark clothes and soft felt hats.

Rosenstihl Bros. Assign to Protect Their Creditors.

BIRMINGHAM, Ala., Feb. 9.—Rosenstihl Bros. were attached by Joseph R. Smith, their landlord, who sued on a writ of attachment for \$5,625 on a three years' rent contract. Soon after the attachment the firm assigned to J. B. Cobbs in order to protect their other creditors.

The attachment caused much surprise. Rosenstihl Bros. say they owed their landlord for only a little more than one month's rent. They say an agent called at their store to collect it Monday morning.

Mr. William Rosenstihl, Jr., head of the firm, was out and the agent was asked to call again. Instead of calling a writ of attachment for the entire amount of the three years' lease with interest was sworn out and served.

The firm's assets and liabilities are about \$8,500 each, exclusive of the rent contract. The firm is one of the oldest and most popular in Birmingham. A legal contest over the rent contract is expected.

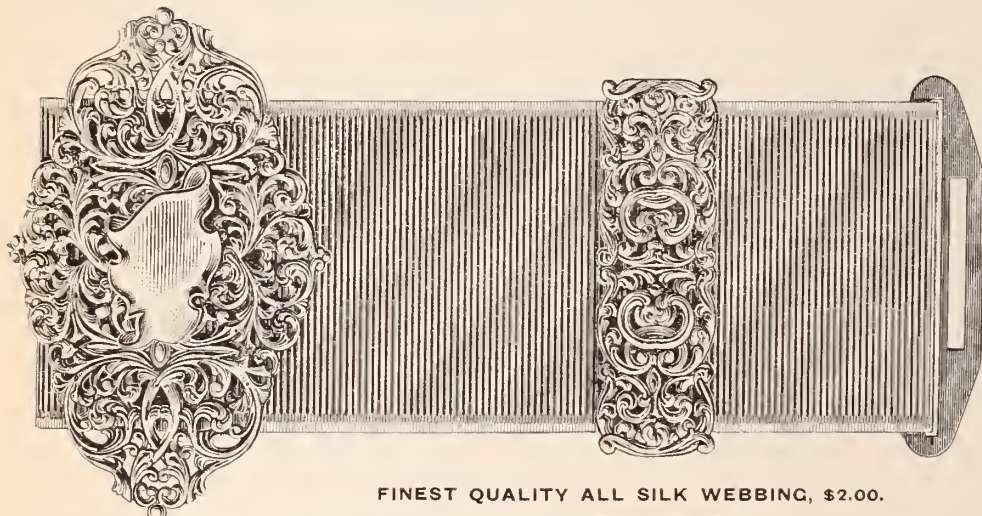

FINEST QUALITY ALL SILK WEBBING, \$2.00.

WE ARE THE ORIGINATORS OF THIS STYLE OF BELT AND WE PROPOSE TO HOLD THE TRADE ON THEM.

We claim that our line of Belts (55 different patterns) are all original and artistic in design, and of best workmanship and finish, and we guarantee them to be much cheaper than any sterling silver Belts made.

**UNGER BROS.,** Makers of  
Fine Jewelry,

In 14 kt. Gold and Sterling Silver, (.925 Fine,) at Salable Prices.

192 BROADWAY, NEW YORK.

**HENRY ABBOTT,**

MANUFACTURER OF

Stem-Winding Attachments

FOR WATCHES,

No. 2 Maiden Lane, NEW YORK.



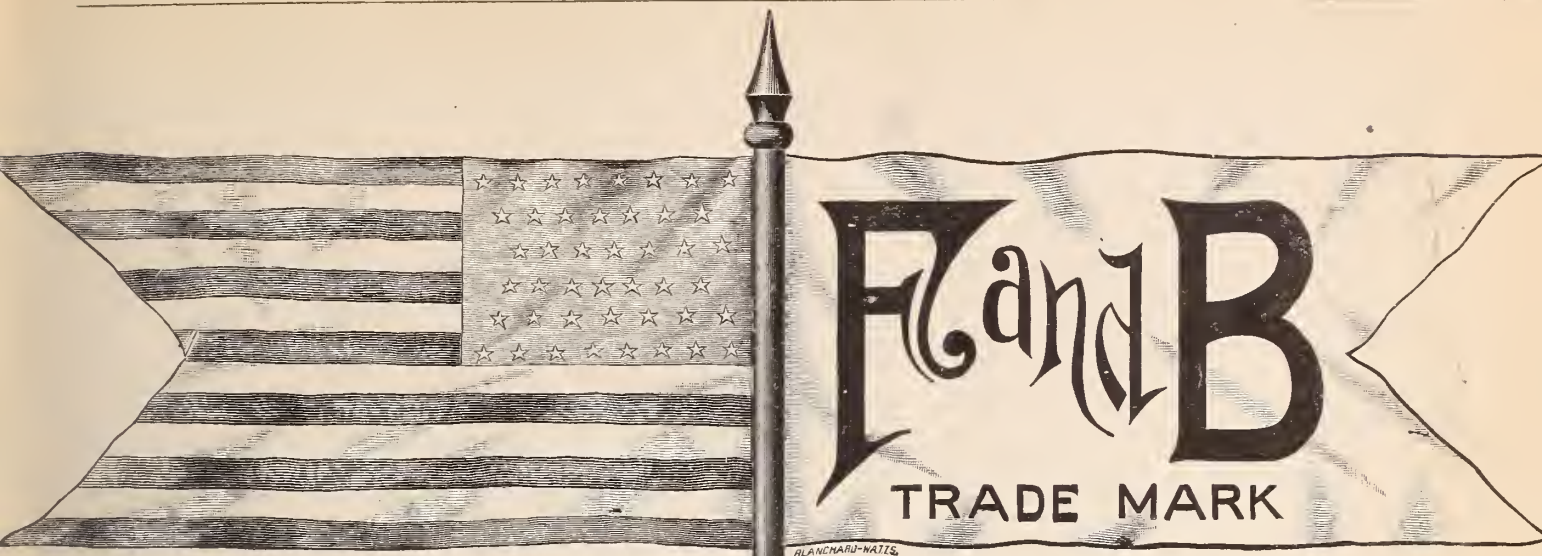

Our American F. & B.  $\frac{1}{10}$  Gold Chains will assay 10 K. 1-10 gold, and are guaranteed for ten years.

Our regular line of Chains is made of heavy gold plate, finely finished, and guaranteed for five years.

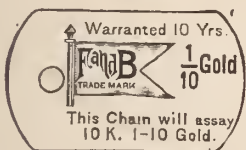

**Chains**  
Our new line of chains will assay 10 karat 1-10 gold. All gold soldered.  
**American F. & B. 1-10 gold.**

WE RECEIVED  
**4 MEDALS**  
AT THE WORLD'S FAIR.

Mount Hope Button.

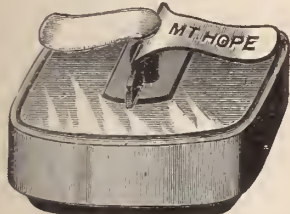

CLOSED.

**Watch Chains for Gentlemen**  
These goods are of fine quality, and guaranteed to give satisfaction. Some recently added have sold far beyond expectation. They are made of heavy rolled plate in all sizes and patterns.

**Watch Chains for Ladies**  
Our Victoria and Princess chains are neat and pretty. They are made in all bright, Roman and bright, platinum and bright gold, and have one or two charms.

Mount Hope Button

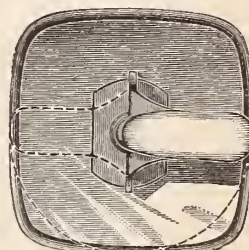

OPEN.

**Charms**  
This line is adapted to ladies' or gentlemen's chains, and includes a number of heart charms - in Roman, bright and satin finish, with stones and without.

**Hair Chain Mountings**  
In solid gold and rolled plate. We are headquarters and make everything desirable in this line.

**Bracelets**  
We make a large stock of curb bracelets in five sizes, besides the graduated links, with padlocks and snaps, in chased and plain polished, Roman, rolled silver plate and sterling silver. Also padlocks with keys and a push snap.

**Pins**  
Our large line of lace and cuff pins comprise many desirable patterns in gold fronts engraved and trimmed. Also includes baby pins and scarf pins.

**"Mt. Hope" Buttons**  
These are superior to any buttons in the world. They are easy to put in and easy to take out of the cuff.

**Link Buttons**  
This line has increased rapidly with us, and is very low in price, embracing all styles in Roman, chased, engraved and plain, with and without stones, and some in enamel.

**Crosses**  
We make four sizes of gold filled in plain, engraved and set with stones, and suitable for our neck chains.

**Sterling Silver and Solid Gold Sword Scarf Pins**

**Glove Buttoners**  
We make the interlocking and one with a twist handle in gold rolled plate and silver rolled plate.

**Earrings**  
This line includes many pretty patterns in gold fronts engraved, some with pretty trimmings and a small line of loop drops.

**Neck Chains**  
We make a variety of neck-chains in bright and Roman, with snaps.

**Sterling Silver Bracelets and Padlocks**

**Gold Lockets Set with Diamonds**  
These lockets are made of 10 karat gold throughout and set with brilliant diamonds. They cannot be surpassed in finish or cheapness of price.

**Gold Lockets Engraved**  
These lockets are also made of 10 karat gold throughout, with beautiful designs engraved thereon and the price is so low that they cannot fail to be in great demand.

**Gold Front Lockets**  
This line is very extensive. Many patterns are plain polished, others nicely engraved, with and without stones.

**Rolled-Plate Lockets**  
This line is almost endless, and consists of nearly every conceivable shape, size and style. Some are set with imitation diamonds, rubies and sapphires.

**TRADE MARK**

**TRADE MARK**

We have put upon the market a line of Gentlemen's Chains and Ladies' Chain Bracelets made of 1-10 gold stock. Every joint is soldered with gold, and every Chain or Bracelet will assay more than 1-10 gold. They are our AMERICAN F. & B. 1-10 GOLD goods, and are so stamped. Bar, Chain and Swivel are stamped 1-10 gold.

**FOSTER & BAILEY, Providence, R. I.**



**Another Argument in Favor of the Present Duty on Precious Stones.**

The proposed increase in the diamond tariff has given rise to new complications affecting other merchants besides the diamond importers and jewelers. Arkell & Douglass, export and commission merchants, New York, received the following despatch Thursday from the DeBeers Consolidated Mines, limited, Kimberley, South Africa:

"All manufacturers dealing with South Africa should take a stand against bill before Congress proposing additional tariff on precious stones. If bill passes Senate you may expect almost prohibitive tariff here on American goods. America should foster an increasing trade, not destroy it. Communicate this cable to all large firms doing business here, and urge them to use united influence immediately at Washington to prevent this increasing tariff on diamonds, which comprise half of the exports from Cape Colony."

The dispatch is signed by Gardner Williams, superintendent of the Consolidated Mines. The junior member of Arkell & Douglass, who was seen at his office Saturday by a CIRCULAR reporter, stated that about 12 large and many smaller firms were engaged in the South African traffic. No concerted action has yet been taken, but he expected that the larger merchants would each write to members of the Senate and ask that in view of this threat, the proposed duty on diamonds be lowered.

Three of the members of the committee of diamond importers, A. J. G. Hodenpyl, the chairman, H. C. Hardy, of H. C. Hardy & Co., and H. H. Treadwell, of Tiffany & Co., went to Washington Sunday, to endeavor to induce the Senate to reduce the proposed diamond schedules.

**EASTERN MANUFACTURERS PROTEST.**

PROVIDENCE, Feb. 10.—The petition, published in THE CIRCULAR last week, is being circulated among the manufacturing jewelers, importers, and dealers in jewelry, diamonds, etc., in this city and vicinity, and is being liberally signed.

Among those who have already signed it in this vicinity are the following: Waite, Thresher Co.; John T. Mauran; C. H. Cooke Co.; W. S. Hough, Jr. & Co.; Arnold & Steere; Flint, Blood & Co.; A. B. Day & Co.; White Stone Jewelry Co.; S. B. Champlin & Son; W. E. Webster & Co.; S. K. Merrill & Co.; Foster & Bailey; Geo. H. Cahoon & Co.; Brown & Dorchester; Baldwin, Ford & Co.; Tilden-Thurber Co.; Ostby & Barton Co.; Richard Robinson & Co.; Wm. R. Dutemple & Co.; D. Wilcox & Co.; Wightman & Hough Co.; T. E. Carpenter; E. L. Spencer & Co.; C. W. Lord; Charles Sydney Smith; R. L. Moorhead & Co.; Julius Eichenberg, and others.

The stock of E. P. Sundberg, Fargo, N. Dakota, was sold Feb. 6 to Mrs. E. S. Berg, who held a claim against it for \$2,400. Mr. Sundberg will probably be appointed agent and will conduct the business at the old stand.

**The Good Work of the Jewelers' Relief Association Continues.**

A meeting of the general committee of the Jewelers' Relief Association took place Wednesday afternoon. President Lissauer presented a full report of the work done by the organization up to that time. The committee decided to make the association a member of the Association for Improving the Condition of the Poor, of Jersey City, Brooklyn and Newark in addition to New York city. The committee also authorized that the following letter of appeal be sent to the trade:

DEAR SIR:—By special request of the Committee of Twenty-Five of the Jewelers' Relief Association, this communication is sent to you for the purpose of again calling your attention to the needs of this association, which was organized for the purpose of assisting worthy artisans of the jewelry and kindred trades who have been left penniless through the prevailing hard times.

The plan of relief adopted is to find employment wherever possible, and otherwise to minister to the absolute physical needs of those applicants who, after a thorough and searching investigation, are found worthy.

To this end we have adopted a system whereby we are able to extend relief to applicants in this city, Brooklyn, Jersey City and Newark.

A complete record of all cases brought to our notice is kept at our office, 11 Maiden Lane, and is always open to your inspection.

Though in a great many cases of destitution temporary relief has been given, a large number still await our action, and new applications are received daily.

Your name not as yet appearing on the roll of subscribers, we ask you to bear in mind the great need and suffering of the many unemployed jewelers and their families, and *again* appeal to you for your aid.

Please send your contribution to Mr. A. J. G. Hodenpyl, treasurer, 170 Broadway, who will duly acknowledge receipt through the trade papers.

MAX J. LISSAUER, *President.*

A. FRANK, *Chairman, R. C.*

The association relieved about one hundred cases of destitution the past week, and supplied work to about a dozen people. The organization wishes to impress the fact upon all who need assistance that their system is such that no publicity whatsoever is given to the names of applicants, so that none of the needy and worthy should fear to make their wants known to the secretary.

The following subscriptions were received by the treasurer within the past week:

Gold Watch Case Manufacturers' Association.....	\$193 76
Ketcham & McDougall .....	50 00
William Moir.....	50 00
Hammel, Riglander & Co.....	50 00
Edward Todd & Co .....	25 00
Rothschild & Bro.....	25 00
N. H. White & Co.....	25 00
M. J. Lasar .....	20 00
L. J. Higham.....	15 00
Theo. A. Kohn & Co.....	10 00
H. N. Squire & Son.....	10 00
Maurice Weil.....	10 00
Leopold Weil & Co. ....	10 00
N. Glauber & Co.....	10 00
H. Henrich.....	10 00
Ferdinand Bing & Co.....	10 00
F. Fuchs & Bro.....	10 00
Chas. Knapp.....	5 00
James H. Folan.....	5 00
F. W. Brower.....	5 00
Vincenzo Miglionico.....	2 00
Cash .....	2 00
Cash.....	1 50
Oscar Houriet.....	1 00
	—————
	\$ 555 26
Previously acknowledged.....	4,715 00
	—————
	\$5,270 26

**The Failure of S. Dessau Carries Down Andrews & Doty.**

Andrews & Doty, diamond brokers, 207 Broadway, New York, the selling agents of the American Turquoise Co., assigned Tuesday, Feb. 7th, to George W. Glaze, lawyer, in the Potter building. The partners are John R. Andrews, who lives at Englewood, N. J., and Joseph G. Doty, who lives at 180 Broad St., Newark, N. J.

The firm began business in September, 1889, as diamond brokers, afterward became importers of diamonds, and later went into other precious stones. Mr. Andrews became president of the American Turquoise Co., organized in Chicago in April, 1892, with a capital stock of \$1,000,000. Andrews & Doty were reported to have an active capital of \$30,000, and Mr. Andrews was supposed to have large outside means. For many years he was connected with Tiffany & Co., and years ago was said to be a large stockholder in that company.

George W. Glaze, the assignee, stated to a CIRCULAR reporter, that Andrews & Doty had been dragged down by the failure of Simon Dessau. They are perfectly solvent, he said, but were forced to assign in order to protect the American Turquoise Co. Their liabilities all told are about \$16,000, of which all but \$3,000 are contingent, while their actual assets are at least \$30,000, but are not immediately available. Dessau owes them \$12,250 on notes. Andrews & Doty negotiated the paper in the bank, and Dessau holds as endorsee Andrews & Doty's paper for \$11,000. There are a series of notes, and those of Andrews & Doty fall due four days before those of Dessau. The first two notes for \$2,300 fall due on the 9th inst., and Andrews & Doty, being non residents, an attachment could be obtained against their property which would tie up all their assets. This might affect a large stock of gems of the American Turquoise Co. which the firm hold. That company is indebted to Andrews & Doty to the extent of \$20,000, but the firm hold 25,000 karats of turquoise as security for the debt. Their liabilities in the trade, the assignee says, are practically nothing, and they owe nothing for merchandise. At the time of the assignment Mr. Doty was in New Mexico, but left for New York Feb. 7th.

A decision handed down by the New York Court of Appeals at the January term, in the case of *Wise vs. Grant*, will prove of importance to the jewelry trade. The opinion, which is written by Chief Justice Andrews, is to the effect that a merchant cannot maintain an action in replevin against a sheriff who has taken possession of a debtor's goods, without first having rescinded the contract under which the debtor obtained the goods, and demanded said goods from the debtor before the sheriff has levied upon the property. It will be seen that this practically stops all replevins from the sheriff.



# The Jewelers' Circular

AND  
HOROLOGICAL REVIEW.

PUBLISHED EVERY WEDNESDAY BY

THE JEWELERS' CIRCULAR PUB'G CO.,

189 BROADWAY, NEW YORK CITY.

A JOURNAL DEVOTED TO THE INTERESTS OF JEWELERS, WATCHMAKERS, SILVERSMITHS, ELECTRO-PLATE MANUFACTURERS, AND ALL ENGAGED IN KINDRED BRANCHES OF INDUSTRY.

Our Editorial columns will contain our own opinions only, and we shall present in other columns only what we consider of interest or value to our readers. Advertising matter will not be printed as news.

Advertising rates in THE CIRCULAR are lower, considering the number of tradesmen reached by its large circulation, than in any other jewelry journal.

Notices of changes in standing advertisements must be received one week in advance; new matter can be received up to Monday.

## INFORMATION FOR SUBSCRIBERS

### Terms of Subscription, Postage Prepaid.

	PER ANNUM
United States and Canada, - - -	\$2.00
Foreign Countries in Postal Union, - - -	4.00
Single Copies, - - - - -	.10

New subscribers can commence at any time.

Payments for THE CIRCULAR, when sent by mail, should be made in a Post Office Money Order, Bank Check or Draft, or an Express Money Order or Registered Letter. All postmasters are required to register letters whenever requested to do so.

Pay money only to authorized collectors having proper credentials. Returning your paper will not enable us to discontinue it, as we cannot find your name on our books unless your address is given.

In changing address always give the old as well as new one. Your name cannot be found on our books unless this is done.

We will continue to send papers until there is a specific order to stop, in connection with which all arrearages must be paid; but such an order can be given at any time, to take effect at the expiration of the subscription. All such orders will be promptly acknowledged by mail.

The Courts have decided that all subscribers to journals are responsible until arrearages are paid in full and an order to discontinue has been received by the publisher.

Member of the American Trade Press Association.

VOL. XXVIII. Feb. 14, 1894. No. 2

THE numerous expressions of praise elicited by the issuing of the Silver Anniversary edition of THE CIRCULAR, do not appear in this number. They require space, a goodly amount of space, and we propose to give them space if they occupy a dozen pages, but not in this number; perhaps in the next or the one next after that.

It is not in accordance with the theory of a revenue tariff to tax even luxuries to such an extent as to obstruct legitimate trade and encourage the traffic of the smuggler. On the ground that diamonds are so easily concealed, most Governments put them on the free list or subject them to a very low rate of duty.—*Philadelphia Record*.

THIS argument in Col. Singerly's Democratic paper shows that sense is sometimes stronger than political partisanship.

THE CIRCULAR has made arrangements for the publication of all invitations of proposals for furnishing the Federal Government with merchandise in the lines represented by this journal. This information

will prove valuable to manufacturers generally. This issue contains the invitation of the Navy Department for the furnishing of silver plated ware for the *Boston*.

### Is the Revival Here?

REPORTS from Chicago lead us to infer that the bright sunbeams of encouragement have parted the clouds of doubt that have cast a dark shadow over mercantile life. The apparent revival of trade finds a larger number of buyers seeking goods, which gives practical evidence that stocks in the country need replenishing. The so-called necessities, as groceries, dry goods, clothing, etc., are moving more freely and the horizon of the jewelry trade is brightening at all points. Renewed confidence has resulted in the establishment of a number of new industries with a stronger tone throughout the mercantile world. Jewelry is regarded to-day hardly more of a luxury than are dry goods and clothing and will follow more closely than ever before, the lead of staples in these lines. There seems to be a general awakening to the fact that lack of confidence in the financial soundness of business houses was in very large measure responsible for the decrease in trade. When this feeling is coupled with a loss of confidence in one's self the result is disastrous. The advancing season has disclosed less business failures than the trade expected. This of itself was encouraging and tended to restore confidence, and now come reports, from all the larger business centers, of an increased number of buyers visiting the jobbing trade.

### Kimberley Heard From.

A NEW phase has been given the proposition now before the Senate to increase the duties on precious stones, by the cablegram from Kimberley, as published elsewhere in this issue, in which it is stated that Cape Colony will place an almost prohibitive tariff on American merchandise if the measure becomes a law. The despatch is signed by the De Beers Consolidated Mines Co., and as Cecil Rhodes is chairman of this gigantic enterprise and also Lieutenant-Governor of Cape Colony, the threat will certainly be carried out, if the tariff on diamonds is changed as proposed. The agricultural interests of the Colony are growing, and every steamer and sailing vessel touching at South African ports take valuable cargoes from America. A large amount of machinery is exported from this country to cultivate the plantations and to work the diamond mines. If the Colony government place a prohibitive tariff on American products, the increasing trade with South Africa of several of our exporters will be practically stopped, while many of our manufacturers will be affected to their disadvantage. However, this is not the strongest argument in favor of leaving the existing tariff on precious stones unchanged. The stronger arguments have

already been presented in these columns. To sacrifice the public revenue and ruin honest merchants for the sake of having a good fling at the rich in campaign speeches is not the business of a Congress of grown men, elected to legislate for the benefit of the people.

THE gentleman who answers the "Queries by CIRCULAR Readers," infers, from the few difficult questions submitted to him, that jewelers are very well informed, or are not great seekers after knowledge. His fund of information will be apportioned out to any one who desires it.

### The Week in Brief.

H. C. BARNUM, traveler for Shafer & Douglas, New York, was robbed of his trunk of goods, but most of the stolen property was recovered and the thief supposed to have been captured—Andrews & Doty, New York, assigned—Mark Streicher & Co., Chicago, Ill., were sued for \$50,000—The safe of E. L. Cooper, Clarence, Mo., was blown open and rifled.—E. G. Sherman's store, Montgomery, Mo., was burned out—An ex-policeman was arrested charged with robbing Rudisill Bros., Altoona, Pa.—Arrangements were effected for the annual convention of the Pennsylvania branch of the National Retail Jewelers' Association—Sahak Arsen, New York, assigned—Several interesting tariff decisions were handed down—The annual meeting of the Hampden Watch Co. was held—The composition offer of Edward Moulton, Worcester, Mass., was confirmed—Cross & Beguelin, New York, incorporated—The Treasury Department issued the summary statement of imports and exports for December, 1893—The Horace Partridge Co., Boston, Mass., incorporated—A receiver was appointed for the effects of Pfeil & Bredt, Chicago, Ill.—Rosenstihl Bros., Birmingham, Ala., assigned.—Pepper throwers robbed H. J. Davison, Springfield, Mass.—The Cowles Electric Smelting and Aluminum Co. have entered suit against the Carborundum Co., Monongahela City, Pa.—Seery Mfg. Co., Providence, R. I., assigned—George E. Whitman, Buffalo, N. Y., assigned—Julia Hess, New York, assigned—An interesting cablegram was received in New York from Kimberley.

### George C. McCormick & Co.'s Affairs.

PROVIDENCE, R. I., Feb. 10.—Assignee A. C. Cushing, of George C. McCormick & Co., of this city, has not as yet fully completed his schedule of assets and liabilities, although it is estimated that the latter will amount to \$18,000 or \$20,000. As to what basis of settlement can be offered the creditors it will be impossible to state until a settlement is effected in the affairs of E. H. Saxton & Co. It is thought; however, that Mr. McCormick will be able to pay 50 cents on the dollar.



### New York Notes.

Isidor Ollendorf, 202 Broadway, will remove to 45 Maiden Lane.

J. T. Scott & Co. have entered a judgment for \$1,366.21 against Alexander Cable.

A judgment for \$322.73 has been entered against Jos. D. Lynch by A. Frankfield & Co.

Oliver M. Farrand has entered a judgment for \$86.42 against Abraham H. Dayton.

The German Exchange Bank has entered a judgment for \$153.79 against Julius Kaplan.

Solomon Meyer has given a chattel mortgage on jewelry fixtures to L. Solomon for \$800.

E. Aug. Neresheimer & Co. have entered a judgment for \$832.73 against Charles E. Hansen.

Lippman Tannenbaum, of L. Tannenbaum & Co., sailed for Europe Saturday on the *Umbria*.

The Mechanics' and Traders' Bank has entered a judgment for \$599.11 against Simon Dessau.

A judgment against Moses J. Lichtenberg has been entered by L. G. Bloomingdale and others for \$191.

Col. Wm. A. Moore, of the Dueber Watch Case Mfg. Co., Canton, O., was in New York last week.

Simon Taros, 226 Henry St., has given a chattel mortgage on jewelry fixtures for \$150 to A. Green.

Louis Oppenheimer now represents Max Freund & Co. in New York city and vicinity, succeeding Max Heil, who is no longer with this firm.

L. Black & Co. will give up their office at 178 Broadway, May 1st, and remove to their old home, Detroit. Their factory was moved to that city last July.

Chas. S. Crossman, 19 Maiden Lane, has gone on a trip to Georgia for the benefit of his health. During his absence Albert Kamp will manage the business.

Edwin A. Thrall, 176 Broadway, will remove to his previous location at 3 Maiden Lane, on May 1st, into the store on the ground floor of the Stevens building.

Geo. A. Miller, the assignee of Silas Stuart, 2 Maiden Lane, is advertising for the creditors of the latter to present their claims to him at 54 Wall St., on or before April 16th.

In Part III of the Supreme Court Circuit, Friday, the Schlichting & Smith Co. recovered a judgment for \$78.05 against Arthur C. Risley, which with interest and costs amounted to \$145.40.

Fred. L. Martin, of Eichberg & Co., was to have sailed for Europe Saturday on the *Umbria*, but owing to illness, he has postponed his trip until next Wednesday, when he will sail on the *Majestic*.

The Fletcher Watch and Jewelry Co., 182 Broadway, and Rubenstein Bros., 48

Maiden Lane, have taken offices in the Diamond Exchange, 14 Maiden Lane, to which they will remove May 1st.

The appeal of Adolph Bernhard from the order permitting Alfred H. Smith & Co. to examine the assignee's books, was argued before the General Term of the Supreme Court, Friday. Decision was reserved.

J. M. Weil & Bros., manufacturers of jewelers' boxes, will remove their factory this week from Buffalo, N. Y. to 81, 83 and 85 Crosby St., this city. Their office, now at 48 Maiden Lane, will also be removed to that address.

Sahak Arsen, a jewelry and watch case engraver and manufacturer of watch cases, 39 Maiden Lane, assigned without preferences Friday, to Geo. A. H. Minasian, lawyer, 38 Park Row. His liabilities are estimated at \$2,000.

Larter, Elcox & Co. intend to give up their New York office, at 21 Maiden Lane. Mr. Larter stated to a CIRCULAR reporter that as soon as they secured a tenant for the premises, their office would be removed to Newark where their factory is situated.

Mrs. Mary Cacace, a widow, has commenced a suit for breach of promise in the Kings County Supreme Court against Myer Buckman, jeweler, 165 Tillary St., Brooklyn. Buckman claims he never promised to marry the woman and that her suit is only a scheme to get money from him.

Among the passengers to Europe last week were: L. J., F. J. and F. A. Errico, of Errico Bros., New York; W. F. Leeder, of Leeder & Bernkoff, Providence, R. I., and Mr. Tchiboukdjian, New York, on *La Gascogne*; L. Tannenbaum, of L. Tannenbaum & Co., New York, on the *Umbria*.

Henry Well has begun a suit against Simon Dessau, 4 John St., to foreclose a mortgage made by Mr. Dessau and dated May 26, 1891, for \$60,600, on the property at 762 to 766 Broadway. Leon Lewin, Mr. Dessau's assignee, states that he is still working on the firm's schedules, which he expects to file this week.

It was reported at Police Headquarters Thursday, that J. Kahn, a pawnbroker, 783 Eighth Ave., had been robbed of \$10,000 worth of diamonds. The stones were taken from his flat, at 128 E. 96th St., Wednesday afternoon, by burglars who broke in while the family were away. The jewels were in rings, studs and loose stones.

Judge Pryor, of the Court of Common Pleas, signed an order Wednesday authorizing J. J. Connelly, the assignee of E. A. Haldiman, to reconvey to Mr. Haldiman the property which he assigned Jan. 23d. Henry Ginnel, 31 Maiden Lane, who bought up all the claims against Mr. Haldiman, gave a bond of \$300 to insure the payment of any claims which might remain.

The firm of J. W. Richardson & Co., manufacturers of solid gold emblems, 194 Broadway, have dissolved by mutual consent, A. B. Gardner retiring. The remaining partner, George H. Richardson, has

formed a new copartnership under the old firm name with Harry H. Butts and W. N. Morris. Mr. Butts and Mr. Morris were in the employ of the old firm for many years, the former for 10 years and the latter over 23 years.

Julia Hess, 247 Grand St. has made an assignment to Henry C. Marshall, of Lawrence Frazier & Co., bankers, giving preferences for \$60 for salaries due employes. Mrs. Hess has carried on business under the name of the Manhattan Watch & Jewelry Co. The sheriff had been in possession for some time on an execution for \$8,621 in favor of S. F. Myers & Co. Henry B. Wesselman, the insolvent's attorney, estimates the nominal assets at about \$25,000; actually worth about \$14,000. The total liabilities, he says, will not exceed \$16,000. Lawrence Frazier & Co. Saturday entered judgment for \$4,374.59 against Ludwig and Julia Hess.

The trial of Louis Arnowitz, jeweler, 891 Ninth Ave., took place before Judge Martine, in Part I of General Sessions, Tuesday and Wednesday. Arnowitz was accused by Philip Ferris of receiving stolen goods which he, Ferris, had stolen from the store of Benj. F. Spink, 359 Sixth Ave., in September. Ferris pleaded guilty to this burglary and that of Lambert Bros.' jewelry store, 58th St. and Third Ave. Wilson F. Lewis, manager for Benj. F. Spink, identified a quantity of the jewelry taken from Arnowitz, as part of that stolen from the store. The jury brought in a verdict of guilty. Arnowitz and Ferris were both sentenced Monday. Arnowitz was sent to Sing Sing for a year and a half and Ferris was sent to the Elmira Reformatory.

### Cleveland.

The Retail Jewelers' Association held a well attended meeting Friday night. Letters were read from a number of out-of-town dealers expressing sympathy with the objects of the association and timely topics were discussed.

A decision was rendered in Common Pleas Court, Friday, which brought the case of Sipe & Sigler against E. R. Hull & Dutton to a temporary halt. Suit was commenced several weeks ago by Sipe & Sigler to recover \$25,000 damages from E. R. Hull & Dutton for alleged injury to the business reputation of plaintiffs, through the publication of an advertisement affecting the character of certain watches manufactured by Sipe & Sigler and sold by J. L. Hudson, a rival clothing dealer to Hull & Dutton. In answer to the petition E. R. Hull & Dutton filed a demurrer setting forth that there was not sufficient cause of action. Judge Lamson sustained the demurrer.

T. Harley, jeweler, Chatham, Ont., bought a gold watch from two men who were afterward arrested for stealing it. Mr. Harley purchased it in good faith and was exonerated by the court from any complicity in the matter.



**Last Week's Arrivals.**

**THE CIRCULAR** has perfected arrangements for obtaining the names and hotel addresses of all the latest buyers visiting New York, and each day posts in its office, 189 Broadway, a bulletin which every member of the trade is cordially invited to copy.

The following out-of-town dealers were registered in New York during the past week: H. Eisenberg, Reading, Pa., Broadway Central H.; S. W. Woodward, Washington, D. C., St. Denis H.; Mrs. J. C. Nourse, Woodward & Lathrop, Washington, D. C., St. Denis H.; M. Strauss, Buffalo, N. Y., Morton H.; A. H. Jarecki, Erie, Pa., Hoffman H.; M. A. Stupp, Burke, Fitzsimons, Hone & Co., Rochester, N. Y., Park Ave. H.; D. O'Hara, Waltham, Mass., Astor H.; A. L. Chester, Westerly, R. I., Astor H.; C. H. Taylor, Chicago, Ill., Astor H.; G. A. Reedpath, R. H. White & Co., Boston, Mass., Brunswick H.; J. Fox, Philadelphia, Pa., Grand H.; A. A. Lipscomb, Washington, D. C., Astor H.; H. A. Guild, Boston, Mass., Astor H.; C. J. Smith, Hartford, Conn., Astor H.; E. E. Grant, Trenton, N. J., Park Ave. H.; James Rule, D. McCarthy & Son, Syracuse, N. Y., 43 Leonard St.; G. M. Upson, Waterbury, Conn., Murray Hill H.; H. E. Kirstein, Rochester, N. Y., Imperial H.; J. Nelson, Dunkirk, N. Y., St. Denis H.; E. L. Everett, Washington, D. C., Cosmopolitan H.

**Concerning the Proposed Silverware Factory in Wallingford.**

WALLINGFORD, Conn., Feb. 10.—Simpson, Hall, Miller & Co. have declared a dividend of 6 per cent. on their capital stock, payable out of the earnings of the company during the past year.

Many of the leading men of the borough, called by invitation of Henry E. Biggins, were in attendance at a meeting held in the office of Gurdon W. Hull, vice president of Simpson, Hall, Miller & Co., last night. The purpose of the meeting was to consider and discuss what concessions might be made by the town and borough in the matter of taxes for the new company, which is to manufacture silver hollow ware that Mr. Biggins, ex-superintendent of the Hartford Silver Plate Co., proposes to start here. It is expected to start with a capital of \$50,000, all of which is pledged.

**Seery Manufacturing Co. Make an Assignment.**

PROVIDENCE, R. I., Feb. 10.—The Seery Mfg. Co., 33 Beverly St., made an assignment this afternoon to Phineas F. Parsons, Providence agent of the Waterbury Brass Co. The firm have been running behind in their payments for some time. Last July their rating was withdrawn by the Bradstreet Agency, although the firm's name appeared in the records on the Fall book. With Dun's Agency, the Seery Mfg. Co. had no rating for the past three weeks.

The Seery Mfg. Co. were not incorporated but were a copartnership between Edward F. Seery and Sidney L. Clarke, formed Aug. 1, 1884, Mr. Clarke coming to this city to enter business at that time from Hartford, Conn., while Mr. Seery, of East Providence, had previously been engaged in the manufacture of jewelry in this city. In 1890 the firm bought out Clarke, Black & Co.

Mr. Parsons, the assignee, will say nothing as to the liabilities and assets of the concern and Mr. Clarke has no statement at present for publication except to deny the report that a meeting of the firm's creditors was held last Tuesday. The creditors will include the Waterbury Brass Co., the platers and stone dealers and other supply men in this city, and it is not thought that the amount of the liabilities will be more than \$10,000 or \$12,000.

**One Young Man Shoots and Kills Another in the Street.**

CLYDE, N. Y., Feb. 8.—James B. Nichols, a young man of this village, was shot and instantly killed by Fred H. Childs, son of Sylvester J. Childs, a jeweler of this place. Childs passed Nichols on the street and fired one shot from behind. When Nichols turned around, Childs fired two more shots into his abdomen, which caused death.

Trouble had been brewing between them for some time, Childs claiming that Nichols had been circulating stories derogatory to himself. The murderer was jailed.

**L. TANNENBAUM & Co.,**

IMPORTERS AND CUTTERS OF

**Diamonds and Precious Stones,**

Cor. Maiden Lane & Nassau St.,

NEW YORK.

25 HATTON GARDEN,  
LONDON.

TELEPHONE,  
Long Distance,  
1959 CORTLANDT

**— We Offer This Week : —**

**EMERALDS.**

35 Emeralds, 20 <sup>7</sup> / <sub>8</sub> kt. less 1-64,	at \$18 per karat
64 Emeralds, 18 <sup>3</sup> / <sub>4</sub> , 1-32 kt. -	at 18 per karat
71 Emeralds, 55 <sup>3</sup> / <sub>4</sub> kt. -	at 50 per karat
1 Emerald, 13 kt. less 5-64 -	at 50 per karat
1 Emerald, 2 <sup>3</sup> / <sub>8</sub> , 1-16, -	at 130 per karat

**RUBIES.**

1 Oriental Ruby, 1 <sup>1</sup> / <sub>4</sub> less 1-64 kt.	at \$75 per karat
1 Ruby, 11 <sup>1</sup> / <sub>4</sub> kt. - -	at 35 per karat
8 Rubies, 8 1-32 kt. - -	at 12 per karat
Small Round Rubies, 30 <sup>1</sup> / <sub>4</sub> kt.	at 6 per karat
Rubies, 36 <sup>1</sup> / <sub>2</sub> , 1-16 kt. -	at 3 per karat
36 Rubies, 20 less 1-64 kt. -	at 11 per karat

**SAPPHIRES.**

Star Sapphire, 24 <sup>1</sup> / <sub>8</sub> 3-64 kt.	at \$20 for the stone
Star Sapphire, 34 less 1-64 kt.	at 50 for the stone
Very fine Sapphire, 3 <sup>1</sup> / <sub>2</sub> less 1-32	at \$75 per karat
Very fine Sapphire, 8 <sup>1</sup> / <sub>8</sub> , 3-64 kt.	at 90 per karat
65 Sapphires, 28 <sup>3</sup> / <sub>8</sub> , 1-64 kt. -	at 5 per karat
55 Sapphires, 25 less 1-16 kt.	at 7 per karat
21 Pink Sapphires, 10 <sup>1</sup> / <sub>8</sub> , 1-32 kt.	at 5 per karat
23 Pink Sapphires, 12 <sup>5</sup> / <sub>8</sub> , less 1-64 kt.	at 4 per karat
23 Fancy Stones, 43 <sup>3</sup> / <sub>4</sub> less 1-32 kt.	at 3 per karat
Olivines, 37 <sup>5</sup> / <sub>8</sub> karat, - -	at 16 per karat

### The Attleboros.

Frank Steward, an aged die sinker, employed by Watson, Newell & Co., died Friday.

S. O. Bigney, of Marsh & Bigney, is suggested as a candidate for the Legislature at the next election.

The engagement of Charles W. Clough, the Pawtucket jeweler, and Miss Serena A. Smith, of that city, is announced.

The cases of John Day and Frank Callahan, charged some time ago with stealing silver from Totten Bros., were heard at Taunton last week. Decision was reserved.

Serina Wilson and Howard Clifton were arrested in Pawtucket last week on a charge of selling silverware without a license. They claimed to represent a Providence firm.

The Attleboro Mutual Fire Insurance Co. last week elected J. W. Capron, president, G. N. Crandall, vice-president, C. L. Watson, A. B. Carpenter, H. A. Clark, L. M. Stanley, C. L. Watson and A. W. Sturdy, directors.

This week the electric lights in North Attleboro will be furnished from the town plant. Theron I. Smith and G. K. Webster were members of the committee that purchased the plant. The lights will be cheap and nearly all the firms have contracted to have them placed in their shops.

### Boston.

C. E. Tilton, formerly of the Allston district, has located in Wells, Me.

Harry W. Olive has bought out the business of Frank C. Kibby, Chelsea.

The Superior Court last Wednesday granted a divorce to the wife of Dean Southworth.

The American Waltham Watch Co.'s factory has resumed after a week's shut down for stock-taking.

Buyers in town last week included H. A. Potter, Pittsfield, N. H.; C. P. Buskirk, Ticonderoga, N. Y.

Herbert Libby, salesman for Charles May, is receiving congratulations. The new member of his family is a girl.

Charles Emerson has bought out the stock at W. L. Rugg's old stand, 1447

Washington St. Mr. Rugg is now in Groton, Mass.

Jacob Lewis has taken A. H. Potter & Co.'s former location on Washington St., and will open under the name of Boston Diamond Co.

Mr. and Mrs. George E. Homer were presented with a little woman on Feb 6th, who will hereafter be known as Mildred Elizabeth Homer.

George W. Stone, of Waltham, is in charge of F. L. Parkhurst's store in Everett, while that gentleman is making a tour of Maine in the interest of a Boston bicycle firm.

C. W. Hoffman, who used to have a store at White River Junction, Vt., and who was later with H. N. Lockwood, of this city, is now in business on his own account at 383 Washington St.

An entertaining stereopticon lecture on the South African diamond fields was given Saturday evening to the Boston Press Club by Capt. George F. Hollis, late United States Consul to the Transvaal.

James N. Hammond, who was foreman at the American Waltham Watch factory, for upwards of 25 years, is to succeed to the foremanship of the watch repairers at Wilson Bros.' establishment.

### Philadelphia.

S. Pastel has opened a repair shop on N. 3d St.

M. J. Sheridan has recovered from a severe attack of the grip.

F. C. Levy has returned from a business trip to New York and New England.

Thos. J. Passmore has opened a new and handsome store on Germantown Ave.

John C. Kelly recently made some extensive alterations and improvements in the interior of his Chestnut St. store.

The sheriff's sale of the effects of the Philadelphia Optical and Watch Co. was last week postponed until the 12th inst.

Charles Clark pleaded guilty in the Court of Sessions on Wednesday last to stealing a pair of opera glasses from the store of Chas. Bellak. He was sentenced to 18 months imprisonment.

A youth named Frank Hill smashed a win-

dow in B. S. Alleman's jewelry store, 4th St. and Kaighn Ave., Camden, on Saturday night last. Just as he was about to grab a trayful of watches a policeman caught him, and he was locked up.

The board of directors of the Keystone Watch Case Co., have placed on record resolutions to the memory of George W. Childs, to whose liberal spirit, sound judgment and active interest the company largely owes their being.

George Hoopes, an ex-policeman, was arrested here early last week charged with numerous burglaries of railroad station offices, post offices, and stores in rural sections throughout the State. The direct cause of his arrest was information furnished by the police of Altoona, at which place Hoopes is said to have gotten away with a valuable quantity of plunder from Rudisill Bros.' jewelry store on Dec. 3d.

The Pennsylvania Retail Jewelers' Association branch of the National Retail Jewelers' Association will hold their annual convention on Feb. 21 and 22, at the association's rooms, 36 N. 9th St. Among the features of the convention will be a lecture by Dr. J. J. McGuigan, A. M., M. D., on practical electricity in its relations to watchmaking; a demonstration of the Weiland optometer by D. V. Brown; an address by Superintendent Marsh, of the American Waltham Watch Co.; a lecture by manager Willis B. Musser, of the Non-Retailing Co.; a theatre party and a banquet.

### Pittsburgh.

Kingsbacher Bros. have entered two judgments against Peter Quinn for \$90 and \$65 respectively.

Jacob Weser, of Wilkensburg, and formerly of the East End, died recently at the West Penn. Hospital.

John Grier, Evans City, sold out last week to R. Johnston, and will soon leave for California, where he will locate permanently.

Fire last week destroyed Buyer Bros.' dry goods and E. S. Hutchinson's jewelry store, at Kittanning, Pa. The latter's stock was saved. Loss, \$3,000.

The Cowles Electric Smelting and Aluminum Co. have sued the Carborundum Company, of Monongahela City, for infringing a patent for smelting ores and for the manufacture of imitation diamond.

Buyers in Pittsburgh last week were: T. W. Gurley, Meyersdale, Pa.; T. E. Griffin, Elizabeth; D. F. Rosen, West Newton; A. C. Gaul, Sharpsburgh; A. Winter, Zelienople; G. A. Boss, McKee's Rocks; J. C. Rhodes, Homestead; P. A. Ritter, Verona; John Zengschmidt, Mansfield; T. G. Scott, Braddock, Pa.; W. W. Titley, Rochester, Pa.; T. N. Smith, Mt. Morris; A. A. Poole, Washington; B. Neville, Dawson; H. H. Weylman, Kittanning; A. F. Stainer, Wheeling, W. Va.; J. Linnenbrink, Rochester; H. Ulrich, Etna; J. B. Bruce, Burgettstown, Pa.; E. H. Kennerdell, Tarentum; and Frank Worrell, Washington.

## Enterprising Jewelers Catch On!



### Jewish Shekel, Masonic Mark or Pocket Piece.

THE LATEST AND BEST SELLING NOVELTY.

The mark is struck in coin silver; by using either the obverse or reverse of the coin, the back being the same in either case, and permitting of the purchaser's name, blue lodge, chapter and individual mark, with date of same being engraved thereon, as shown in cut above.

Price, without engraving, ONE DOLLAR. Engraved Mark, Dates, etc., 75c. EXTRA.

Liberal Discount to the Trade.

CHAS. G. WILLSON, MANUFACTURING JEWELER, READING PA.



**Interesting Decisions by the Board of General Appraisers.**

WASHINGTON, D. C., Feb. 10.—A decision has been reached by the General Appraisers in the matter of the protest of Hamburger & Co., against the decision of the Collector at New York, as to the rate and amount of duties chargeable on certain watch charms, lead pencils, etc. The opinion is in the language of General Appraiser Tichenor, who says:

“As appears from samples submitted, the goods here subject of protest, which are invoiced as ‘patent pencils,’ are in the form of small pipes, the bowl portion being made of briar wood and the stem of metal, containing a pencil lead with an extension screw to carry it the length of about one-half inch, and is mounted with a metal band with a ring attached, for the apparent purpose of affixing it to a watch chain as a charm, the whole being about two inches in length. They were assessed for duty at 50 cents per gross and 30 per cent. ad valorem under the provisions of paragraph 466, N. T., and are claimed by the protestants to be dutiable at 50 per cent. ad valorem under the provision for jewelry in paragraph 452, N. T.

“Although the articles are apparently designed to be attached to watch chains and worn as charms, they are clearly adapted and designed for use as lead pencils. We find as matter of fact: (1) That the goods in question are of the character above described; (2) That they are not composed of precious metals or imitations thereof, and are not commercially known as jewelry. The action of the Collector in the assessment of duty on the goods is affirmed, and the protest is overruled.”

In the matter of the protests of R. F. Downing & Co., against the decision of the New York Collector regarding the rate and amount of duties chargeable on unwrought glass discs imported by that firm, the opinion of General Lunt is as follows:

“We find: (1) That the protestants imported into the port of New York, under the tariff act of 1890, as shown above, certain glass, which was assessed for duty at 1 3/8 cents per pound under paragraph 112, and 10 per cent. ad valorem in addition under paragraph 118 on the colored glass as unpolished cylinder window glass not exceeding 10x15 inches square, and which the protestants claim is entitled to free entry as glass plates or disks, unwrought, for use in the manufacture of spectacles and eyeglasses, as provided in paragraph 591; (2) That said merchandise consists of plates or discs of white, to wit, uncolored and colored unpolished cylinder glass, varying in thickness and cut into rectangular, oval, or round outlines, the extreme dimensions of the pieces being 1 3/4 inches; (3) That this glass is of a special quality expressly designed for use in the manufacture of optical instruments, spectacles, and eyeglasses, and in the form as imported is suitable only for such use. Upon these findings the protests are sustained.”

# ADELPHI SILVER PLATE CO.,

**62 JOHN STREET,**

**NEW YORK.**

—  
**FACTORIES:**

**124, 126, 128 & 130 Pearl Street,**

**BROOKLYN, N. Y.**



No. 208. BUTTER DISH, Fancy Repousse. List. \$6.00 each.



No. 27. ICE PITCHER. Double Wall, Porcelain Lined. Rich Repousse. List. \$18.00.

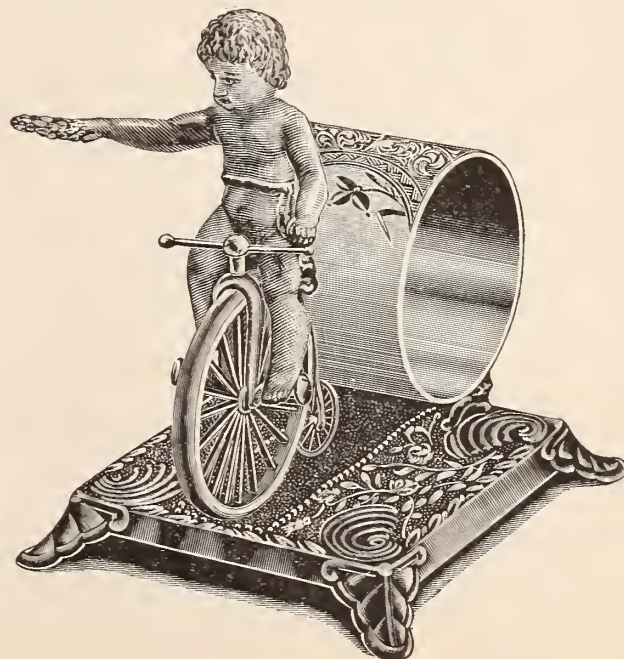

No. 11. NAPKIN RING. Satin Bright Cut. List, \$36.00 per dozen.



STAR PEOPLE WESTWARD TAKES ITS WAY

# WESTERN SUPPLEMENT

## of THE JEWELERS' CIRCULAR

**Chicago Office: Room 308, Inter-Ocean Building.**

VOL. XXVIII.

CHICAGO, WEDNESDAY, FEBRUARY 14, 1894.

NO. 2.

### Chicago Notes.

Joseph Fahys paid the Chicago office a visit last week.

M. E. Nebstedt, Davenport, Ia., is visiting Chicago friends.

Gen. George Mindel was last week in the city selling the American Watch Case Co.'s product.

The American Silver Plate Co. have secured a judgment on verdict for \$317.08 against the Uncle Sam Souvenir Co.

Mr. Moses, late with Eichberg & Co., visited Chicago trade last week as the representative of the Philadelphia Watch Case Co.

Frank Carpenter and F. A. Jeanne, travelers for Alfred H. Smith & Co., visited Manager Rich, of the Chicago office, the past week.

The business of J. H. Gilbert, manufacturing optician, Masonic Temple, who recently died, will be continued by Mrs. Gilbert under the same firm name.

Taylor & Titus, diamonds, report business picking up. The first week in February showed an excess of sales over the same week a year ago and each of several weeks past has shown a steady improvement.

The Green Bee Trading Co., a new concern, the past week purchased in this city a jewelry stock for a general store to be opened in the new mining town of Cripple Creek, Col.

The Brooklyn Watch Case Co. will vacate their quarters at room 511, Columbus building, the present month and move the stock and safes into rooms 502 and 503, the sales-rooms of Jos. Fahys & Co.

E. Keller has given to C. Leseberg a two years chattel mortgage on jewelry, etc., for \$2,412. The city directory reads: "Emil Keller, jeweler, 9203 Commercial Ave." "Charles Leseberg, furniture, 10104 Ave. K."

The E. Howard Watch & Clock Co. are putting in one of their largest striking town clocks in the court house at Laporte, Ind., and have recently thoroughly equipped

the handsome Chicago Athletic Club house with a fine set of clocks.

A. H. Bradley, formerly Chicago manager for Bates & Bacon, is seriously ill with Bright's disease, at his home, 2317 Indiana Ave. For several years past Mr. Bradley has been troubled with gravel, and Feb. 1 last the malady developed into Bright's disease. Feb. 5 and 6 he sunk until unconscious, but rallied slightly. It is thought he can live but a few days at the longest.

The Seth Thomas Clock Co. have closed a contract with President Mallory, of the First National Bank, Chariton, Ia., for a six-foot glass dial clock, which will be presented by that gentleman to Lucas County and placed in the tower of the new court house at Chariton. The company also have contracts for clocks for the court house at Lawrenceburg, Ky., and Richland Centre, Wis.

M. C. Eppenstein denies the report published in THE CIRCULAR Jan. 31st, that the firm of which he is the head stocked a store in Detroit and opened an auction sale. "We do not know the concern" said he, "and have no interest in that or any similar concern anywhere in the United States. We have no interest outside of our wholesale house at 163 State St. The statement was entirely without foundation."

May 5, 1893, the World's Fair exhibit of L. Manasse, optician, 88 Madison St. was looted of opera glasses, etc., valued at \$348.25. A Columbian guard who should have been relieved at 11 p. m. abandoned his post at Manasse's exhibit before the relieving sentinel came and it is believed the cases were opened during his absence. A claim for the value of goods stolen was filed with Chief Peabody, and Director General Davis' attention called to the matter; when no action was taken by the authorities, a court suit was begun and Feb. 5 Mr. Manasse secured a verdict against the Columbian Exposition for the full amount.

Handsome silver prizes for the festivities of the Sons of New York, held Feb. 6th, consisted of sterling handled pocket knife for gents' first prize; match box for second

prize; a gold lined ladle for first prize for ladies; and a sterling mounted tortoise comb for ladies' second prize. The pieces were suitably engraved and were selected from stocks of leading silversmiths by M. N. Burchard. Prominent among the Sons of New York were noted: M. N. Burchard, manager Rogers & Hamilton Co.; James A. Todd, manager Towle Mfg. Co.; Clayton B. Shourds, of Shourds & Kasper; Morris H. Berg, of Hyman, Berg & Co.; and J. H. Purdy, of J. H. Purdy & Co.

Charles Potter, "Consul-General for the Hawaiian Islands," was last week locked in a cell at the Desplaines St. police station on the charge of obtaining money under false pretenses. He was engaged in a number of questionable deals and was arrested by detectives in front of C. D. Peacock's jewelry store after leaving an order at that place for a pair of diamond earrings and a gold watch, to be sent to a rich lady on Michigan Ave. Potter had been tracked by detectives for several hours, and when arrested had \$7,000 in Homer Hawaiian Sugar Company bonds and a satchel containing \$500 worth of jewelry. A druggist and liveryman appear as complainants. Potter was removed to the County Jail Wednesday.

"Encouraging," "picking up," "hopeful," "better," "increasing," and optimistic adjectives in all their forms are the replies of the majority of houses to inquiries as to trade conditions. Since the close of the Fair the stereotyped reply, "No one in this week," has been repeated "many times and oft." A relief to this monotony was afforded by many houses the past week, and the remark, "Why, there were quite a number of buyers," showed that the depleted stocks of the country merchant were, at the least, being patched up. Buyers noted in the city who will be prepared to show customers a good line for selection include Charles T. Axt, Odell, Ill.; G. Anderson, Saylerville, Ill.; F. W. Moore, Maywood, Ill.; R. C. Plum, Hillsdale, Mich.; F. Mair, South Bend, Ind.; C. J. Peterson, St. Charles, Ill.; M. V. B. Rowley, Hillsdale, Mich.; Riecks Bros., Clinton, Ia.; J. R. Schneider, Evanston, Ill.; C. J. Linden, Kankakee, Ill.; A. Gluck, Dodge City, Kan.;



B. W. Lee, Dekalb, Ill.; J. F. Ingalls, Waukegan, Ill.; C. T. Ottaway, Canton, Ill.; Hesla Bros., Tama, Ia.; J. S. Brown, Williamsport, Pa.; W. W. Denny, Aurora, Ill.; J. W. Burkett, Arlington Heights, Ill.; W. S. Evans, Hiawatha, Kan.; Eggermann & Son, Aurora, Ill.; W. P. Yeoman, Waukegan, Ill.; Mr. Hofer, Kansas City, Mo.; Mr. Merrill, St. Paul, Minn.; M. E. Nabstedt, Davenport, Ia.; Geo. O. Warren, Sycamore, Ill.; A. R. Knights, Dubuque Ia.; Mr. Doty, Boise City, Idaho; Mr. Smyth, Elgin, Ill., J. L. Akerman, Monon, Ind.; A. R. Stanley, Austin, Ill.; J. R. Mercer, Kansas City, Mo.; Mr. McKenny, Mt. Carroll, Ill.; George F. Beach, Valparaiso, Ind.; W. A. Maurer, Council Bluffs, Ia.; N. E. Benoit, Rockford, Ill.; T. S. McCoy, Seneca, Ill.; J. B. Fosters, Beloit, Wis.; Frank Foote, Lake Mills, Wis.; H. E. Fox, Geo. W. Hickox & Fox, Albuquerque, N. M.; Mr. Weakley, Lowell, Ind.; W. H. Vail, Valparaiso, Ind.; Green Bee Trading Co., Cripple Creek, Col.; J. S. R. Scovell, Ft. Madison, Ia.; Charles F. Lefmann, Laporte, Ind.; R. J. Spence, Racine, Wis.; John Peterson, Dundee, Ill.; Mr. Smith, Harward, Ill.; Aug. Shearer, Oak Park, Ill.; C. S. Hayes, Norfolk, Neb.; J. E. Haep, Montpelier, O.; J. E. Dick, Peotone, Ill.; M. A. Spater, St. Paul, Minn.; S. C. J. Peterson, Morris, Ill.; E. J. Peck, Braidwood, Ill.; M. Morris, St. Louis; Geo. Bridstone, Cleveland, O.; E. F. Winegar, Kenosha, Wis.; Andrew Rov-elstad, Elgin, Ill.

Jan. 24th the Rockford Watch Co. sued Tilley & Lund for \$1,000. Feb. 8th a judgment by default for \$515.25 was granted the company against Frederick Lund.

Besides the acceptance of reports from the committee appointed to co-operate with the Central Relief Association, no action of importance was taken by the Chicago Jewelers' Association, at their regular monthly meeting, Feb. 6th.

A handsome battery of large safes is the first consignment of furniture for the new quarters to be occupied by G. W. Marquardt & Sons, 402 Columbus building. It is understood the firm will be settled in their new rooms the latter part of the month.

Manager Loeb, of the Wadsworth Watch Case Co., says the business of the Chicago office the past month was larger than during any of the Fall months of 1893. The new O size vermicelli star has made a decided hit and the factory at Newport is running full force and full time.

E. J. Peck, conducting jewelry stores at Braidwood and Gardner, Ill., reports business all right and fully up to last year's. "We are in the coal district," said he; "and things are busy there. There is an income of \$50,000 a month in ready cash for coal, and it helps us out nicely."

John Neville and Thomas O'Brien secured a continuance to Feb. 9th under bonds of \$3,500 each, for robbing Greenberg's pawnshop, 55 W. Randolph St., several weeks ago. The men overpowered

the clerk and looted the safes of several thousands dollars' worth of diamonds and jewelry.

No decision has been reached on the bids for stock and fixtures of Wm. Bigler. Two sealed bids were received by assignee Dovale, but have not yet been accepted or made public. A number of local retailers have examined the stock with a possible view to purchase, and the store is still open in charge of the assignee.

In the case of the Dueber Watch Case Mfg. Co. vs. Max Young, an appeal was taken from a verdict for \$738.07 in favor of the case company, and a bond and bill of exceptions will be filed in 40 days. The Dueber Co. think they are entitled to some \$2,500.

#### The Late George C. Shreve's Interest Sold to Shreve & Co.

SAN FRANCISCO, Cal., Feb. 6.—Wilfred Montague and H. L. Dodge, executors of the will of George C. Shreve, the jeweler, have petitioned Judge Coffey for permission to sell deceased's interest in the firm of George C. Shreve & Co., to the company recently incorporated by George Bonny, A. J. Lewis, the surviving partners, and the widow. They have been offered \$69,594 for the interest, and in addition, the heirs to the estate have been offered 1,000 shares of the capital stock of the new corporation. Judge Coffey granted the application.

#### Death of an Old Time Clock Man.

BUFFALO, N. Y., Feb. 8.—Timothy A. Hopkins died this week. He was born Feb. 5, 1806, in what is now the town of Amherst, and aided his father on the farm, receiving only the ordinary educational advantages of that early day. In 1826 he

located in Elyria, O., and engaged in the manufacture of cast iron plows, which were then being introduced. In 1828 he sold his interest in that business and began the sale of Connecticut clocks, continuing until 1836. His trade was extensive, and agents traveled through Ohio, Pennsylvania, Kentucky, Michigan and Canada. Since 1844 he has been in various lines of manufacture.

Mr. Hopkins had a successful military life and was lieutenant-colonel in the State militia when he resigned. He filled the highest offices of his town. The Democratic party elected him to the Assembly in 1863 and again in 1864, where he served on important committees. He was the justice up to 1885, and did his last official work in November, 1884. He was public spirited and had the welfare of his town at heart.

## Engravers' Type.

A Rubber Type in new styles specially adapted to Engravers' use. Seven different sizes now ready.

*Minnie S. Foster*  
*Sir Walter Scott.*

Does away with all tracing. Letters are stamped upon the article in clear cut script or old English.

The outline can readily be engraved by even the apprentice.

Type made on new principle, bevel edged; alignment guaranteed.

Every Engraver should have it. Write for particulars.

WM. H. DIETZ,  
117 Dearborn Street, Chicago.

## REED & BARTON, SILVERSMITHS,

MANUFACTURERS OF

STERLING *and* SILVER PLATED  
SILVER WARE.

SALESROOMS:

37 Union Square, New York.

34-36 WASHINGTON STREET,

Venetian Building, Chicago.

FACTORIES, TAUNTON, MASS.

## OPTICAL DEPARTMENTS ESTABLISHED.

An EXPERT OPTICIAN will thoroughly establish an Optical Department in a limited number of FIRST CLASS JEWELRY STORES, giving his own time as promoter until on a successful basis. Will also give complete instructions in fitting to the man designed as head of the department.

### THERE'S MONEY IN IT.

Jewelers wishing to make a special run in their optical department or establish one, will find this a rare opportunity. Your business can be increased \$1,000 to \$2,000 a month. Arrangements can be made either on percentage or salary. An unusual opportunity for a good house to

### ENTER A LUCRATIVE FIELD.

ADDRESS  
OPTICIAN, Care JEWELERS' CIRCULAR, Chicago Office,  
308 INTER-OCEAN BUILDING, CHICAGO.

# DUEBER-HAMPDEN WATCHES.

The most reliable watches are the Hampden 17 Jewel. A full line of Dueber Cases and Hampden Movements. Cash buyers write us.

**BRETHAUER WATCH & JEWELRY COMPANY,**  
SPECIAL AGENTS,  
71 WASHINGTON ST., - - - CHICAGO, ILLS.

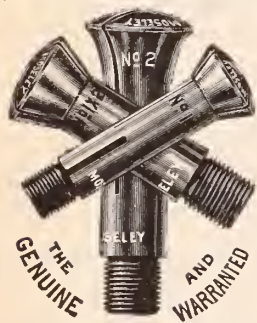

## 1892. GRAND DROP NUMBER TWO. 1894.

All Genuine Moseley No. 1, No. 1x2 and No. 2 Chucks are now listed at \$1.00 each.

IMPROVED TOOLS ENABLES US TO DO THIS. QUALITY GOING UP AND PRICES GOING DOWN.

Good Chucks and more of them are what the watchmaker and repairer needs to do their work correctly and more rapidly. We do not reduce the price or quality of the Lathes, but add more than enough chucks to the combinations to make up for the reduction of the chucks.

7 Chuck Combination,	\$42.00.	-	-	-	-	Now, 10 Chucks,	\$42.00
10 " "	46.00.	-	-	-	-	" 14 "	46.00
15 " "	51.00.	-	-	-	-	" 20 "	51.00
25 " "	71.00.	-	-	-	-	" 33 "	71.00
33 " "	80.00.	-	-	-	-	" 42 "	80.00
48 " "	106.00.	-	-	-	-	" 60 "	106.00

MOSELEY & CO., - - - 36 River Street, Elgin, Ill.

Will take effect Jan 20th, 1894.  
When interested write your Jobber, or



## GIBSON HOUSE,

CINCINNATI, OHIO.

ABSOLUTELY FIRST-CLASS AMERICAN PLAN HOTEL.

\$3.00 PER DAY.

Extra Charge for Parlors and Rooms with Bath attached. The unequalled advantages in central location, liberal management, modern appointments, experienced service and perfect cuisine, have permanently established the Gibson House as The Most Popular First-Class Hotel in Cincinnati.

AMPLE VAULTS FOR THE PROTECTION OF VALUABLES.

THE GIBSON HOUSE CO.,

H. B. DUNBAR President and Manager.

## DALE CHUCKS.

Manufactured by



HARDINGE BROS.,

Successors to HOROLOGICAL TOOL CO.,

1036 LINCOLN AVE.

For Sale by all Jobbers.

CHICAGO.

## WM. BIRMINGHAM & CO.,

MANUFACTURERS OF

All Kinds of Leather Spectacle and Eye Glass

CASES,

728 Arch Street, PHILADELPHIA, PA.

## Detroit.

A notice has been issued to the creditors of F. G. Smith, Sons & Co., calling a meeting in this city, Monday, Feb. 12th.

N. Merkle, of this city, has purchased a stock of goods here and will shortly start for California, where he will open a jewelry store.

The Peninsular Fishing and Shooting Club gave its annual ball here last week. Henry Koester and Albert Schaub are among its best known members.

The International Optical Lens Co. filed their report last week, as follows: Capital stock, authorized, \$10,000; paid in, \$3,000; personal property, \$4,765.88; debts, \$2,032.40; credits, \$266.52.

Henry Caspary, formerly of Genicke & Caspary, has engaged in business as a manufacturing jeweler at 29 Monroe Ave. Mr. Genicke is managing the business of the old firm.

Business was quiet last week with the jobbers. The following Michigan country jewelers were in the city: C. D. Draper, Plymouth; J. S. McGlauchlan, Wyandotte; C. E. Montford, Utica; and Mr. Baxter, Birmingham.

Charles Price, a notorious crook with several rewards resting on his head, was arrested here last week. A telegram was received from Cincinnati, O., stating that he was wanted there for stealing \$1,800 worth of goods from a jewelry store in that city.

The United States Optical Co. filed their report last week: Capital stock, authorized, \$100,000; paid in \$53,900; real estate, \$34,126.64; personal estate, \$26,114.04; debts, \$58,097.66; credits, \$22,095.83. The firm will shortly commence building an addition to their new factory on Miami Ave.

The following changes have been made in the force of traveling salesmen of the Johnston Optical Co.: C. M. Scammel from the office now covers the territory formerly held by N. K. Standart; G. A. Douglass and Don C. Phillips are new men, the former covering Indiana and Ohio, and the latter Wisconsin and Minnesota. The firm have nine men on the road and all report business as very good.

## Kansas City.

Burglars broke into E. L. Cooper's jewelry store, at Clarence, Mo., a few nights ago and blew open the steel doors of the vault. They then made away with all the valuable jewelry within the vault and much of the silverware left on the shelves. Mr. Cooper's loss amounts to several hundred dollars.

WHEN IN CHICAGO, VISIT THE

# Chicago Watchmakers' Institute,

SUITE, 1521-1523 B MASONIC TEMPLE.

A Modern Trade School for the Watchmaker, Jeweler and Engraver.

Write for New Catalogue.





E. G. Sherman's jewelry store, Montgomery, Mo., was totally destroyed in a big fire there on the night of Feb. 7th.

The stock formerly belonging to J. Niles Kimball has been purchased by R. N. Hershfield, from J. M. Garner, the assignee.

The face of the big Howard clock in the tower of the Federal building is now illuminated by a powerful incandescent light and reflector placed on the southeast corner of the Hall building, across the street.

Bud Johnson, a negro crook, was arraigned before Justice Swingley a few days ago on the charge of having burglarized Jeanneret's jewelry store, Kansas City, Kan. He told the court that he was guilty of the charge and that he did not want a preliminary trial. He was remanded to jail to await trial at the March term of the District Court.

Robert C. Pahr, connected with Ezra F. Bowman & Co., Lancaster, Pa., is suffering from the effects of a mishap which befell him in Philadelphia on Monday last. He slipped on the icy pavement and as he is a heavy man, struck the sidewalk with such force as to render him unconscious. He was removed to his hotel and was confined to bed until Thursday, when he was able to return to his home in this city. His back is badly injured.

**Cincinnati.**

O. E. Bell is out on a business trip.

Albert Bros. are sending out very handsome calendars to their customers.

Joe Hellebush has returned from a trip and reports sales fair. Mr. Hawkins goes out this week.

Newton Dexter, secretary of the Business Men's Association of New York State, is registered at the Gibson House. His mission in Cincinnati is to meet jewelers for the purpose of organizing an association to fight the schemes of those manufacturers who cooperate with outside houses. He is calling principally on the retail trade.

Julius Duhme, one of the family of the well known jewelers, met with an accident Tuesday last. He was in the Smith building and tripped on the stairs leading to the second floor, falling down the whole flight. He will probably recover, as there are no bones broken. He has retired from active business, but is still in his prime.

**Mark Streicher & Co. Sued For \$50,000.**

CHICAGO, Ill., Feb. 10.—Joseph Zuckerman vs. Mark Streicher and Ignatz Schwartz, case, \$50,000, is among the new suits filed Thursday in the Circuit Court. Zuckerman was formerly a retail dealer and the de-

fendants comprise the firm of Mark Streicher & Co., wholesale jewelers, 205 Madison St.

"The facts of the matter are briefly these," said David J. Wile, attorney for plaintiff: "Zuckerman was engaged in the retail business and sold goods on commission. He loaned the defendants three or four thousand dollars and took notes for the amount. As security Streicher & Co. put a lot of goods on consignment with Zuckerman and entered into a written agreement not to withdraw the goods without a 30 days notice, and not under any circumstances until the notes had been fully paid. The goods consigned were a miscellaneous lot of jewelry and diamonds. Some one started a suit against Zuckerman and Streicher got frightened and gave a 30 days notice that he would withdraw the consigned goods. Zuckerman claimed that under his written agreement he did not have to give up the stuff till a balance of \$1,700 on the notes had been paid.

"Streicher had Zuckerman arrested on a charge of larceny and he was bound over to the grand jury, which returned a finding of no bill against him. Hence this suit for \$50,000 for breaking up complainant's business, malicious prosecution and false imprisonment."



The only Genuine Chuck is the TRUE One.

The only Chuck made invariably true is the Dale.

**BUY THE ONLY GENUINE CHUCK, THE DALE, \$1.00.**

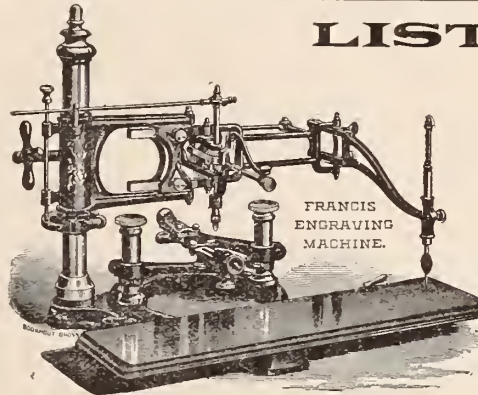

**LIST REDUCED,**

**FOR 30 DAYS ONLY,**

And STRICTLY for Cash With Order.

The List of the

**FRANCIS ENGRAVING MACHINE**

Has been in some respects greatly reduced.

The Plain Bench Machine Reduced from \$75 to \$50.

For further particulars write to your Jobber or to the Manufacturer,

**A. E. FRANCIS,**

780 Cedar Avenue, Cleveland, Ohio.

February 15, 1894.

**The Wadsworth Watch Case Co.**



Filled



Cases.



General Offices,  
**NEWPORT. KY.**

Chicago Office,  
**COLUMBUS BUILDING.**



### Pacific Coast Notes.

The nine-year-old daughter of jeweler H. B. Woelfel, San Jose, Cal., was shot by a rifle bullet fired by some careless hunter. The little girl was not killed.

Oakland, Cal. is having a sensation just now, the occasion being the attack upon jeweler William Faessler, whose wife gave him a dose of the whip in his store a few days ago. The wife claims that her husband was more devoted to what she calls his socialistic correspondence than to her or anything else.

One of the large rooms in the United States Court house in San Francisco was covered with an assortment of jewelry last week. The occasion was the trial of a suit against the Northern Pacific R. R. Co. by M. Wunsch & Co. for damages caused by a collision and fire on one of the trains of the road, in which was a traveling salesman of the plaintiff firm. The trunks of samples were battered and partly burned.

Ygnacio Perez, a pearl diver of Lower California, recently found a pearl valued at \$7,500. It arrived here a few days ago. It is said to be one of the most perfect speci-

mens ever discovered in the Gulf of California. Perez found the pearl on Dec. 29 in an oyster which he secured on the coast about sixty miles north of the lowest point of the east coast of the peninsula. A handsome reward was paid him by the owners of the pearl concession for his discovery.

The Mid-Winter Fair is now in full swing in San Francisco, and many out-of-town dealers are taking advantage of the low rates to visit the city on a sort of clean-up buying and settling of old scores. Trade is not very active, however, and small failures continue to be reported from all along the coast. Many lines of novelties are being put on the local market in the shape of souvenir pieces of the Fair. Among the list is a line of watches whose cases are engraved with the buildings of the Fair.

### Minneapolis and St. Paul.

C. H. Johnson, Marshall, Minn., has sold out to C. E. Meader.

The store of the Donelson Jewelry Co., Minneapolis, recently assigned, is closed.

L. Finkelstein, St. Paul, has removed from 163 E. 7th St. to No. 84, same street.

John Ducan, buyer for A. H. Simon, St. Paul, has returned from a week's trip to Chicago.

The Reed & de Mars Jewelry Mfg. Co., Minneapolis, are at work on a 400 page catalogue.

John Bach, for the past two years watchmaker for Weld & Sons, Minneapolis, last week departed for New York where he intends to locate in business.

M. C. Kummerer, Minneapolis, who has been located on the ground floor of 232 Nicollet Ave. for a number of years has moved into the Guaranty Loan building, ninth floor.

Out-of-town jewelers visiting the Twin Cities the past week were, Kerry Conley, Spring Valley, Minn. N. C. Pabst, Fargo, N. Dak.; L. Diacon, Chaska, Minn.; A. Mealey, Delano, Minn.

A. E. Hall, western representative of the Holmes & Edwards Silver Co. and the Manhattan Silver Plate Co., while in Minneapolis on the 6th, received a telegram announcing the death of his wife at Spring Valley, Minn. Mrs. Hall had been a sufferer with consumption for over a year.

Eastern jobbers and manufacturers represented in the Twin Cities, the past week were Geo. H. Fuller & Son., The Wm. Rogers Mfg. Co., by A. H. Clinger; Meriden Britannia Co., W. C. Wood; L. Combremont, Wm. Dietz; S. & B. Lederer, G. Rodenberg; Goodfriend Bros. & Lassner, Louis Lassner; E. I. Franklin & Co. Geo. L. Payne.

Egbert Coleman, of Minneapolis, recently arrested on a charge of adultery with Mrs. Grace Caswell, failed to appear in the police court. His bail of \$300 was forfeited. He is supposed to have flitted to join his innamorata, who is also missing. Coleman bought and sold diamonds and had headquarters in the Minnesota Loan & Trust building.

Wm. E. Roundy, charged with embezzlement by the Reed & de Mars Jewelry Co., Minneapolis, was indicted by the grand jury on the 3d inst., and was arraigned in the Criminal Court the day following on a charge of grand larceny. He entered a plea of not guilty and his bail was fixed at \$300. His trial will take place on the 16th inst.

Suit was brought in the Municipal Court on the 7th inst., by Samuel Gruenberg to recover \$350 from Moses Weinstein, jeweler, 107 Washington Ave., S. Minneapolis. It is alleged that the money was lost in the back room of the store at a game of poker. A complaint similar to the present one was made by jeweler S. Gittleson, of this city, several months ago, and Weinstein was charged at that time with keeping a poker room.

Mrs. Emily C. Kasten, wife of Chas. J. Kasten, of the C. Preusser Jewelry Co., Milwaukee, Wis., died at the family residence last week.

... THE ...

## American Horological Institute

AND TECHNICAL SCHOOL OF LANCASTER, PA.,  
LATE OF PHILADELPHIA, PA.,

A Trade School where Watchmaking is taught practically. We do not manufacture

☀ BICYCLES OR DYNAMOS ☀

at this institute. We confine our work strictly to WATCH WORK and its kindred branches, which include

≡ Engraving, Jewelry Work and Optics ≡

One tuition pays for all the branches. We do not have boy instructors at this institute, all men of years of experience. Each department has its separate instructor. Our institute is open for inspection. We kindly invite you to visit us and inspect our school modes of giving instruction and the progress that our students make by giving them practical instruction.

**THOMAS PENDERGAST,**  
PROPRIETOR AND MANAGER.

## PATENT FIBRE-FACED HAMMERS.

5 oz. for Watchmakers.  
10 oz. for Manufacturing Jewelers.  
Price 50 Cents Each.

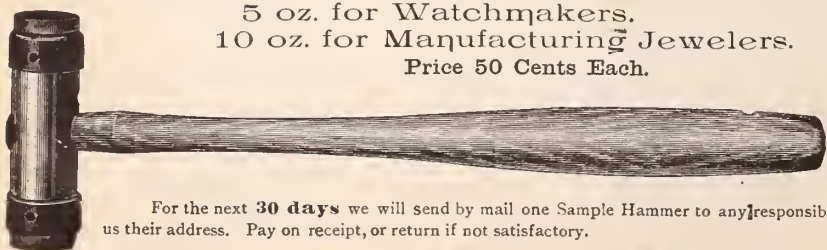

For the next 30 days we will send by mail one Sample Hammer to any responsible firm, giving us their address. Pay on receipt, or return if not satisfactory.

**W. W. OLIVER, Sole Manufacturer, - Buffalo, N. Y.**

Send for our No. 10 Catalogue.



# PROMINENT FIRMS OF THE WEST.

## GOLDSMITH BROS.

**T**HE firm of Goldsmith Bros., refiners and assayers, 63-65 Washington St., Chicago, first came into existence at Lexington, Ky., in 1867, under the name and guidance of M. Goldsmith, the father. As youngsters the Goldsmith boys, Moses and

suits being made two years later than that of his elder brother. Both make occasional trips, but the bulk of road duty now falls to I. Speyer, a brother-in-law of Moses Goldsmith, Mr. Speyer coming to the firm in 1886.



MOSES GOLDSMITH.



SIMON GOLDSMITH.

Simon, played about the shop and became identified with the business that in later life they developed into the leading sweep and old gold and silver refinery in the west. Mr. Goldsmith, Sr. died in 1882, when a fair volume of trade had been established, and the sons succeeded to the business under the name of Goldsmith Bros.

In 1884 the firm moved to Chicago and located at 13 S. Canal St.; but within four years they had outgrown their quarters and moved to larger rooms at 63-65 Washington St., a central location convenient to the jewelry trade, whose business the firm had always aimed to secure. Their constant principle to be prompt and accurate in their returns and to give satisfaction to their customers has been rewarded by their always keeping a customer once secured. On this their great success is based.

Moses Goldsmith, the elder of the two brothers, was born in Cincinnati, O., Sept. 8, 1860. The family, in 1869, removed to Lexington, Ky., where he attended the public schools, and during vacations worked about the shop and learned the business. In 1876 he attended the Agricultural Mechanical College at Lexington, where he mastered a graduate course in chemistry. After the college course Mr. Goldsmith traveled for the firm in eastern and southern territory, continuing on the road up to 1882, the time of his father's death.

The history of one of the brothers is the history of both. Simon Goldsmith was born in Cincinnati, Aug. 3, 1862, and followed his brother in College and road life, Simon's entry in both educational and business pur-

The dental department is under the able superintendence of Mentor Mayer, who also looks after the manufacture of jobbing wire and plate for jewelers' use.

The home life of the brothers is most happy. The elder, in 1884 wedded Miss Fannie Speyer, of Lexington, and two bright children bless the union, a boy of eight and a girl of six, bringing sunshine to the beautiful home at 1045 N. Clark St. Simon Goldsmith, December last, married Miss Julia Nussbaum, of Plymouth, Ind., and the couple are now on a tour of California. In all that goes to make success, Goldsmith Bros. both individually and as a firm, have achieved marked distinction.

### A Receiver for the Partnership Effects of Pfeil & Bredt.

CHICAGO, Ill., Feb. 9.—On the petition of Chas. H. Pfeil, George Gary, has been appointed receiver for the partnership effects of the late firm of Pfeil & Bredt. Mr. Pfeil in a Superior Court bill states that property belonging to the partnership is in the hands of various persons and asks for a receiver to gather it together and satisfy unpaid claims against the firm. The outstanding obligations are very small.

At the time of the dissolution of the partnership it was agreed between Messrs. Pfeil and Bredt that all collections should be made by bookkeeper Steck and turned over to the attorneys. It is stated Bredt collected money which was not so turned over. Bredt's account was overdrawn \$3,000 and Pfeil demands an accounting.

## CHAS. H. PFEIL, MANUFACTURING JEWELER. Diamond Work a Specialty.

**BEST of Workmen.  
BEST Design Work.  
GUARANTEED Workmanship.**

Send a trial order and be convinced.  
**182 State St., Chicago.**

**HUGO MUELLER,  
182 State St., (Room 70,) Chicago.  
FINE WATCH REPAIRING  
IN ALL ITS BRANCHES.  
Work for the trade promptly executed by skilled workmen.**

**PARSONS : SCHOOL  
—FOR—  
WATCHMAKERS,  
PEORIA, - - - ILL.  
Send for Circular and Terms.  
PARSONS & CO.**

**G.A. WEBSTER  
42 & 44 Madison St., Chicago, Ill.  
Manufacturer  
AND WESTERN AGENT FOR  
E. G. WEBSTER & SON, of Brooklyn, N. Y.  
A. F. TOWLE & SON CO., of Greenfield, Mass**

**R. M. JOHNSON,  
IMPORTER OF  
Diamonds AND Manufacturing Jeweler,  
67 WASHINGTON STREET,  
ROOMS 5 & 6,  
CHICAGO.  
MASONIC EMBLEMS OF EVERY DESCRIPTION MADE TO ORDER.**

**THE PLANCHAMP & BECKER CO.  
Makers and Repairers of  
WATCH CASES,  
Gold and Silver Plating —  
— of Watch Cases a Specialty.  
UNEXCELLED FACILITIES.  
53 and 65 East Washington St., Chicago.**

**WATCH CASE MAKERS AND REPAIRERS.  
BOLSTAD MANUFACTURING  
AND PLATING CO.,  
GOLD AND SILVER PLATERS.  
DESIGNING AND ENGRAVING.  
170 Madison Street, - - CHICAGO.**

**ELGIN HOROLOGICAL SCHOOL,  
THOROUGHLY PRACTICAL.  
COMPETENT INSTRUCTORS.  
Send for Prospectus.  
ELGIN, ILL.**



Bredt now is in the diamond business in the Columbus building and Pfeil has established a factory at 182 State St., where his work met with the approval of the trade to such an extent that he has already enlarged the space occupied last month.

#### Incorporated to Deal in Jewelry Patents.

Boston, Mass., Feb. 9.—The Horace Partridge Company have incorporated in this city with a capital stock of \$200,000 in a single share of \$100 to import, manufacture and deal in toys, novelties, notions, fancy goods, chinaware and jewelry patents and patented articles, and to act as agents.

The promoters are Horace Partridge, Cambridge, Mass.; Benj. H. F. Hunt, Cambridge, Mass.; Fred R. Smith, Braintree, Mass.; Frank P. Partridge, Cambridge, Mass.; and Geo. M. McCallar, Cambridge, Mass.

#### Providence.

D. F. Adams, of this city, has discontinued his New York office.

W. H. Harris has commenced a retail business at 62 Wickenden St.

The annual meeting of the Gorham Mfg. Co. corporation will be held next week.

E. C. Ostby, of Ostby & Barton Co., is recuperating for a few weeks in Florida.

David Bernkopf, of Leeder & Bernkopf, is to join the ranks of the Benedicts in a few weeks.

Catlow Bros. are settled in their new shop at 61 Peck St., where they will manufacture a line of cheap plate goods.

Eugene Fenner has been succeeded by Willard Davis, as clerk in the local office of the Jewelers' Mercantile Agency.

The monthly meeting of the directors of the Manufacturing Jewelers' Board of Trade will be held on the 17th inst.

John F. Allen, of Allen & Jonnasshon, has been in town the past week superintending the arranging of stock for the current season.

Theodore W. Foster and Hiram Howard have been elected members of the executive committee of the Advance Club for three years.

C. A. Crowell, formerly with John E. Hopkins & Co., has accepted the management of the New York office of Marden & Kettelty.

Clark P. Tillinghast, of Tillinghast & Albro, has so far recovered from his recent illness from pneumonia, as to be able to attend to business.

On the calendar of the Appellant Division of the Supreme Court for the present term are the cases of John H. Bommele *vs.* William C. Greene & Co. and Henry A. Kirby *vs.* Anchor Pearl Co.

William A. Hickey, for the past 21 years in the employ of Michael Fitzgerald & Co., as foreman for 16 years, has severed his connection with that firm and started in the manufacturing of band rings at 19 Page St.

Thomas J. Gardiner, Jr. has sold his interest in the firm of Richard Robinson & Co., which was organized the first of this

year, to Frank H. Purrucker, formerly in the employ of W. E. Webster & Co. Mr. Gardiner is now traveling representative for George M. Baker, refiner.

The annual charity ball of the First Light Infantry Regiment was held on Monday evening last, and was a very brilliant affair. Among the members of the various committees were: Ex-Gov. Herbert, W. Ladd, Howard O. Sturges, Joseph H. Fanning, Capt. Herbert S. Tanner and Corp. Gregor Kreitchbaum.

#### Connecticut.

A. W. Turner will open a jewelry store in Willimantic.

The Westfield Plate Co., Thompsonville, are running the works until nine at night, with a full force.

Local manufacturers are interested in the failure of Liebman Bros. Co., Brooklyn, N. Y., to some extent.

D. J. Lewis, Tempe, Ari., has opened a repair shop for watches and jewelry in Hudson's drug store.

F. E. Browne, salesman for the Waterbury Watch Co. has sailed for Jacksonville on the steamship *Cherokee*.

The Middletown Plate Co. have posted a notice that the working time will be seven hours a day four days in the week.

E. A. Stebbins, Rockville, closed his business Thursday night and will return to his home in Springfield Mass.

J. Weiner, a Portland jeweler, is missing. The previous occupant of the store he is conducting, committed suicide a short time ago.

H. D. Pierce, western agent for the Winsted Optical Co., West Winsted, is making arrangements for an extensive trip to the west.

The Thomaston clock shops have started up to run 8 hours a day and the watch factory to run full time having a goodly supply of orders on hand.

Henry H. Stockder, paymaster of the Britannia Co., and Miss Bertha L. Swan, daughter of Mr. and Mrs. Oliver Swan, of Meriden, will be married on Feb. 14.

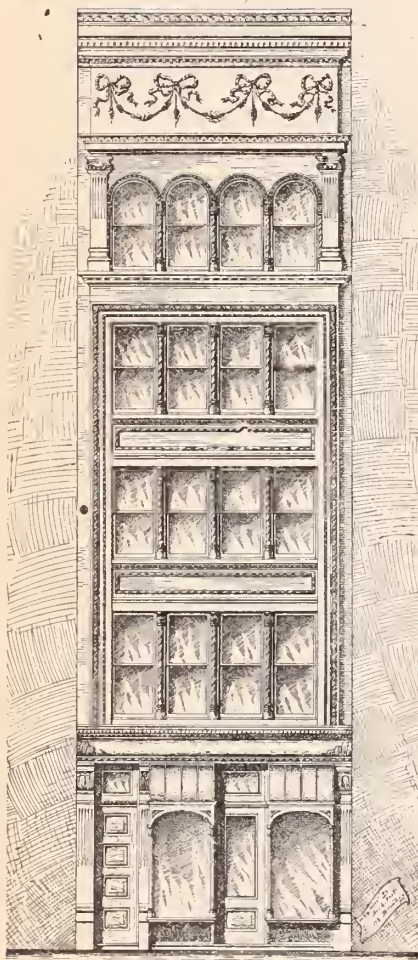

## TO LET

IN THE

HANDSOME NEW OFFICE BUILDING  
45 MAIDEN LANE,  
STORE 130 FEET DEEP.

Excellent Light Throughout at Reasonable Rent, also OFFICES Light and Cheerful, with elevator, steam heat, electric light, best of plumbing and all modern conveniences, at rentals from \$350 up. For further particulars, apply to

E. A. Cruikshank & Co.,  
176 BROADWAY, N. Y.

## MATHEY BROS., MATHEZ & CO.,

21 & 23 MAIDEN LANE, N. Y.  
BRASSUS, SWITZERLAND.

Manufacturers and Importers of  
Plain and Complicated  
WATCHES.

## SPLITS

A SPECIALTY.

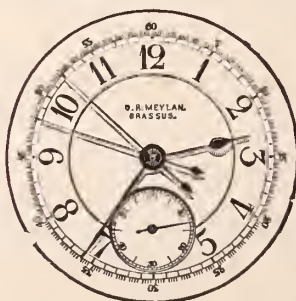

Sole Agents for  
\*\*\*\*\*

## Jacques Lecoultre Razors.



T. Sedgwick Steele, formerly a prominent Hartford jeweler, has exhibited his still life paintings in William & Everett's and at Stowell's in Boston, where they attract much attention.

Work at the Derby Silver Co.'s factory, Birmingham, is rapidly picking up. Monday last nearly double the number were at work that were employed at the opening of the mill the previous week.

George H. Wilcox attended the annual meeting of the Meterbetchouan Fishing Club, in Bridgeport, Feb. 7th, of which United States Senator O. H. Platt was elected president and Ex-Congressman S. W. Kellogg, vice-president.

E. E. Arrington, of Boston, presides as auctioneer at day and evening sales of jewelry and silverware in New Haven, conducted by M. Schwed, president of the Manhattan Jewelry Co., the goods being said to be from an assignee's sale in New York.

Paschal Converse, aged 83, for over 30 years the leading contractor at the New Haven Clock Co.'s works and previously a contractor under the Jerome Clock Co., both when it did business in Bristol and afterwards in New Haven, has been bereaved of his wife, who was 79.

George L. Streeter, for 25 years or more a well known jeweler of New Haven, was in that city last week on a flying visit. Mr. Streeter is doing a good jewelry business in East Orange, N. J., to which place he removed after a stay of two years at Fredericksburg, Va.

The trustees of the Louis Hahn estate, New London, are disposing of the stock at private sale as fast as possible. They have just received an offer for the entire

stock and fixtures made by H. J. Macomber, formerly in Mr. Hahn's employ who resigned to engage in business on his own account.

The house, 76 Main St., Hartford, where Mrs. Violet Hamilton, who is charged in New York with baby farming, says she got a baby which was about to be thrown away, is the house of David Meyer, the jeweler, who is much respected in this city. He denies that a baby was ever taken from his house and laughs at Mrs. Hamilton's story as incredible.

E. F. Strickland, formerly traveler for and later western manager of the New Haven Clock Co., Chicago, has accepted a position with the Waterbury Watch Co., and will in due course call on his friends and hopes to renew the agreeable relation of the past. His home address where mail will always reach him promptly, is Benton Harbor, Mich.

The stockholders of the Manning & Bowman Co., at their annual meeting Feb. 8th elected these directors: E. B. Manning, H. A. Manning, Robert Bowman, J. H. Parsons, G. H. Wilcox, George Rockwell, G. M. Curtis and George E. Savage. E. B. Manning and Robert Bowman were re-elected president and secretary, respectively.

The stockholders of Simpson, Hall, Miller & Co. held their annual meeting Feb. 8th and re-elected as directors: Samuel Simpson, G. W. Hull, Edward Miller, of Meriden; James K. Grey, of Middletown; C. H. Brown, Andrew Andrews and William Whittaker. The officers elected are: Samuel Simpson, president; G. W. Hull vice-president and general manager; C. H. Brown, treasurer, and Andrew Andrews, secretary.

## "Best" Eye Glasses.



The "BEST" Guard embodies some new features of great value. The lower part is rigid, the upper part is flexible. Made in both shell and cork. Must be seen to be appreciated.

Sample Eyeglass Frame, in 10k. gold.	- -	\$2.90
" " " in Steel or Nickel,	-	.35
Sample Pair of 10k. Gold Guards,	- - -	.85
" " of Nickel Guards,	- - -	.15

### Geneva Optical Company,

69 WASHINGTON STREET,  
CHICAGO.

**FANCY DIALS** TO FIT AMERICAN WATCHES.  
**\$6.00 per doz.** IN FLAT SECONDS.  
**\$7.20 per doz.** IN PRESSED SECONDS

Jobbers, Importers and Retailers generally, will be re-bated by sending to us any Dials of our make which they may have on hand.

O'HARA WALTHAM DIAL CO., Waltham, Mass.

### PATENTS SECURED WITHOUT FAIL OR DELAY.

Send Rough Sketch or Model and I will tell you whether you can obtain a patent, WITHOUT CHARGE.

Fifteen years' experience. Ample references. Address

**C. T. BELT,**  
WARDER BUILDING, WASHINGTON . C

# OPPENHEIMER BROS. & VEITH, WATCHES AND

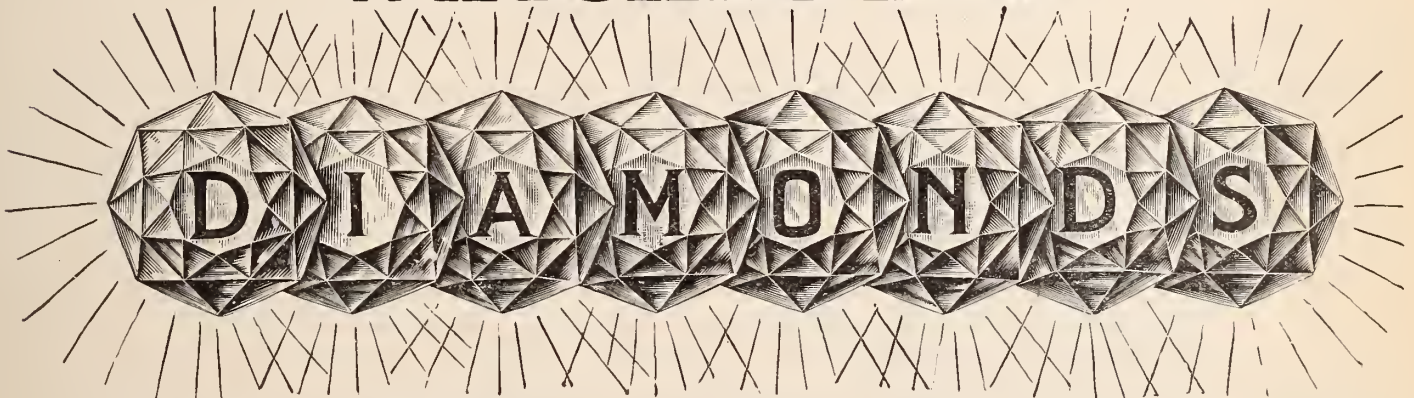

A Large Line of DUEBER Solid Gold Cases. Filled Cases. Silver Cases.  
Our Specialty: HAMPDEN MOVEMENTS, 6, 16 and 18 Sizes.

AMSTERDAM, HOLLAND, 2 TULPSTRAAT. LONDON, ENG., 28 HOLBORN VIADUCT. NEW YORK, 35 MAIDEN LANE.



**DIAMONDS.**

**Wm. S. Hedges & Co.,**

**Importers of Diamonds.**

And Manufacturers of DIAMOND JEWELRY.

**170 Broadway, New York.**

22 Holborn Viaduct, London.

**R. A. KIPLING,**

Importer of

**PRECIOUS STONES,**

**21 & 23 Maiden Lane,**

**19, RUE DROUOT,  
PARIS.**

**New York.**

**CALIFORNIA  
MIDWINTER FAIR.**

**Novelties**

IN  
Sterling and Plated  
Souvenir Spoons, Silver  
Plated Trays, Match Boxes,  
Paperweights, Charms, Sleeve  
Buttons, Rings, etc., etc.

**Julius Eichenberg,**

**174 Weybosset Street,  
Providence, R. I.**



Elk, Shrine and Masonic  
Emblems a Specialty.

Badges of Every Known Order.

**G. A. SCHLECHTER,**

Manufacturing Jeweler.

READING, PA.

**Alfred H. Smith & Co.,**

**IMPORTERS**

**DIAMONDS**

AND

**PRECIOUS STONES,**

**182 BROADWAY, COR. JOHN STREET.**

**NEW YORK.**

88 Holborn Viaduct, London. E. C.

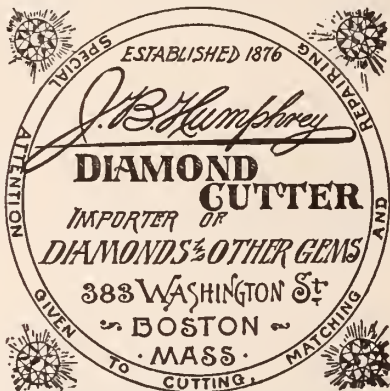

**LEON FAVRE,**

Ivory and  
Enamel  
Miniatures

Best

Workmanship.



**107 E. 26th Street,  
New York.**

Original  
Inventor and  
Patentee of

**Miniatures**

—ON—

**Gold and  
Silver.**

PATENTED  
November 12, 1889.

THE PRICE OF MINIATURES IS NOW \$3.00 INSTEAD OF \$6.00 AS FORMERLY.

**Proposals for Silver Plated Ware for Federal Naval Vessels.**

WASHINGTON, D. C., Feb. 10.—The Navy Department is inviting proposals to be opened Feb. 20th, for furnishing silver plated ware for the equipment of naval vessels during the current year. The items specified below are for the *Boston*, and are to be delivered by April 1st:

Two waiters, 2 sugar bowls, medium; 2 milk pitchers, 1 castor, 1 butter dish, 1 baking dish, medium; 2 vegetable dishes, 1 water pitcher, 1 fish knife and fork, 1 crumb scraper, 4 nut crackers, 1 teapot, 1 gravy ladle, 1 meat dish, 18 inch; 1 bread tray, 1 gravy toast, 1 butter knife, 1 black coffee pot, 1 cheese scoop, 4 salt spoons, 1 mustard spoon, 2 pepper mills, 2 sugar tongs, 2 baking dish linings.

The following are the official specifications for silver plated ware, and will govern the delivery of the articles required:

1. The articles to be of the kinds as shown on the list.
2. The base metal shall be hard metal, known as nickel silver; the same to contain as much nickel as is practicable to work in the combination.
3. The hollow ware to carry the heaviest plate made in the country.
4. The flat ware to be plated as follows, the base metal containing at least 18 per cent. of nickel:  
Table spoons and forks... 18 ounces to the gross.  
Dessert spoons and forks... 12 ounces to the gross.  
Teaspoons... 9 ounces to the gross.  
All other spoons and forks to be composed of same material and to be of correspondingly heavy plate.
- Handles of knives to be of same base metal as forks and spoons; hollow handle, tangs to be pinned with steel pin at bolster, and blades to be of forged steel; the same not to be drop-forged.
5. Every joint and mount to be silver-soldered.
6. Hinges to be of one piece of metal.
7. Handles to have suitable and thoroughly efficient protection by non-conductors where the same may be required.
8. The design of each article may be seen upon application to the Equipment Officer, Navy Yard, New York.
9. Each article shall be marked, as shown on the samples, as follows: For flag officer, two stars and the letters U. S. N.; for captains, an eagle and U. S. N., and for ward-room messes, an anchor and U. S. N. The marks upon the hollow ware to be engraved, and upon the flat ware to be stamped or engraved as shown.
10. The Department will have any one or more of the pieces of each set stripped for the purpose of test, but will reimburse the contractor for the re-plating, provided the set passes the inspection.
11. Delivery to be made at the Navy Yard, New York; deliveries must be complete sets; each set will be inspected separately.

**Bids for the Federal Town Clock at Troy, N. Y.**

WASHINGTON, D. C., Feb. 10.—Bids have been opened by the Supervising Architect of the Treasury for furnishing a tower clock for the United States Public Building, at Troy, N. Y. The following were the bidders: E. Max Fasoldt, Albany, N. Y., \$2,375; time to complete the work, 90 days. Standard Electric Time Co., New Haven, Conn., \$950; time to complete the work, 60 days. Self Winding Clock Co., New York, \$900; time to complete the work, 60 days. Joseph Barbarka, Iowa City, \$1,050; time to complete the work, 4 months. E. Howard Watch & Clock Co., New York, \$950; time to complete the work, 90 days. Seth Thomas Clock Co., New York, \$755; time to complete the work, 3 months.



**Trade Gossip.**

The Towie Mfg. Co., Chicago, are in receipt of many orders from their travelers and country merchants and report trade improving.

W. B. Durgin, Concord, N. H., has issued an artistic booklet in embossed claret colored covers, illustrating in photogravure sixteen of the most popular patterns made by this house; weights are also given, making the booklet specially valuable to the trade.

Theodore C. Steinhaus, who lately started in business as a manufacturer of fine cases and trays for jewelry and silverware at 10 Maiden Lane, New York, already reports a very prosperous and promising trade. He manufactures everything, from sample cases to fine hardwood chests for silverware. Mr. Steinhaus is no stranger to the trade, having formerly been with S. C. Jackson, for 26 years, the last four years as manager. His ability in this line of business is well known and is a guarantee that his work will be of the highest standard. One of Mr. Steinhaus' specialties is manufacturing linings and cushions for silver novelties.

Jewelers who are anxious to display their jewelry and silverware with the greatest possible effect and in the minimum of space, will recognize the importance of the advantages to be derived from the use of Fletcher patent system of trays. Both in wall cases and show cases this system has proved a perfect success, the trays being supported in an absolutely invisible manner. One of the greatest advantages of this system is the fact that there is no obstruction whatever. The entire floor, also the space between the trays, is clear room to work in; viewed from the front, end or at the back nothing can be seen nor touched but the trays. An illustrated catalogue will be sent to jewelers on application to the Fletcher Mfg. Co., 259 W. 27th St., New York.

As a complete and radical departure in the construction of watches, the "Charmilles" watch described elsewhere is the latest triumph. It is so constructed that the greatest value is in the movement and yet at slight extra expense, it is handsomely cased. The entire stem-winding and pendant hand setting mechanism is simplicity itself, and consists only of nine parts and five screws. The price of these watches is so low and their advantages so apparent that they should meet with a large sale.

An Easter novelty in the shape of a book marker, having four solid silver tokens of good size, is offered by Queen & Co., Philadelphia. It is mounted on card board, 10 inches in length, at the top of which is stamped with steel die the words, "Easter Greeting." A nice exhibit of these in a store window before Easter will be sure to effect sales. We understand these book markers retail for 50c., \$1.00 and \$1.50.

The Sterling Silver Mfg. Co., Baltimore, Md., which, by an infusion of new blood and fresh capital, emerged from the Klank

ESTABLISHED 50 YEARS.

**RANDEL, BAREMORE & BILLINGS,**

IMPORTERS OF

**DIAMONDS,**

AND OTHER PRECIOUS STONES.

**FINE PEARLS A SPECIALTY.**

MANUFACTURERS OF

**DIAMOND JEWELRY,**

IN THE LATEST DESIGNS.

**Diamonds Recut in Modern Styles or Repaired on Premises.**

58 Nassau Street,  
29 Maiden Lane  
NEW YORK.

1 Tulp Straat,  
AMSTERDAM.

1 St. Andrews St.,  
Holborn Circus,  
LONDON, E. C.



TRADE MARK.

ESTABLISHED 1841.

**CARTER, SLOAN & CO.,**

**MANUFACTURERS OF GOLD JEWELRY,**

No. 15 MAIDEN LANE,

NEW YORK.

A. CARTER, JR.  
A. K. SLOAN.  
C. E. HASTINGS.

GEO. R. HOWE  
WM. T. CARTER.  
WM. T. GOUGH.

FACTORY, NEWARK, N. J.

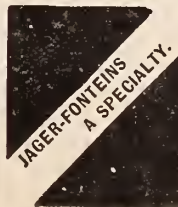

**JOHN N. DISSELKOEN,**  
Cutter and Importer of  
**DIAMONDS**  
FACTORY,  
76 LANGEBLEEKERSPAD  
AMSTERDAM.  
19 East 16th St.,  
NEW YORK.

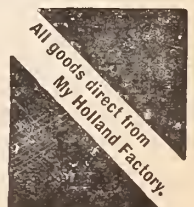



Mfg. Co., recently passed the first twelfth month of their existence with a good yearly record. Their factory ran full time every working day in the year, and for two months previous to the holidays made double time. The company started out well with sufficient capital and with the fixed policy of paying cash for everything, and selling to the trade only. They manufacture solid silver hollow ware and flat ware, and a full line of white metal goods, besides doing considerable repairing and replating. Their new and original designs in hollow ware have proved very taking. The factory is at present at the old stand, 110 W. Fayette St., the office and salesroom being at 17 N. Liberty St.

The proverbial saying that the tailor wears ill-fitting clothes is recalled by the broken horseshoe sign over the main entrance to the Excelsior Sign & Mfg. Co.'s salesrooms, 56 State St., Chicago. Mr. Grout explained that when a firm looks after the interests of the whole world, it was not always possible to spare time to oneself, and a walk about the factory convinced the writer that there is much truth in the statement. Huge trade signs, of which watches and spectacles formed a principal part, were everywhere in all stages of completion. A painter was giving the finishing touches to a 46 inch Louis XIV. watch that will adorn the front of Walter & Hafner's store, Hillsboro, Tex., while Owen & Rustamier, who have opened a store in Canton, Ill., will soon be the happy possessors of a Grout's Louis XIV. Elsewhere a glazier was fitting blue glass into Brobdignagian spectacles. Expressmen were tumbling boxes across the floor, and Manager Grout himself, with saw and hammer, was fitting a watch sign into its packing case. And it takes 12 pages of the large catalogues of leading jobbers to simply give an idea of the prominence Grout's Excelsior trade signs have attained.

**A Notable Work in Silver.**

**T**HE silver vase presented to Henry W. Sage by the trustees of Cornell University on his 80th birthday is of classic form, and stands about 18 inches in height.



THE SAGE TESTIMONIAL.

It is simple and dignified and graphically tells its own story. On the front in bold relief stands the graceful figure of Generosity

with outstretched hands, calling attention to the noble gifts that Mr. Sage has made the University, and which consist of the Sage College, the Sage Chapel, the Cornell Library, and the endowment of the School of Philosophy. The three first are represented by copies of the buildings, and the last is symbolized by the introduction of the Greek Temple of The-eus, with a simple scroll on which is placed the one powerful word, Philosophy. Running in and out and encircling all these is the ivy wreath of friendship. All the work which lies back of the figure, is very artistically etched.

On each side of the shoulder of the vase is introduced the head of Minerva. Around the neck and forming with the oak leaves a border, is the quotation, "On earth there is nothing great but man; in man there is nothing great but mind." Around the lower and narrow part of the piece is a band on which is the verse, "Glory to God in the Highest, and on earth peace, good will toward men." On the reverse side is the following inscription:

Presented to Henry W. Sage on his 80th birthday, Jan. 31, 1894, by former and present trustees of Cornell University, over whom, as Chairman of the Board he has presided for almost 20 years, as a mark of their esteem and affection for the man, and of their grateful appreciation of the devoted love, the wise and zealous service, and the munificent gifts which he has lavished upon the University.

This beautiful testimonial stands 17 1/8 inches high and weighs 132 ounces, and is the work of Tiffany & Co. The work reveals the handiwork of the same artist, James H. Whiteside, who designed the famous "Bryant Vase" now in the Metropolitan Museum of Art.



FULL SIZE NEW ROCCOCCO.

**THOMAS W. LIND,** Manufacturer of **Jewelers' Findings,**

**67 FRIENDSHIP STREET, PROVIDENCE, R. I.**

Call or send for samples of my New ROCCOCCO PATTERNS, for Picture Frames, Cane Heads, Whips, Boxes, Napkin Rings, etc.

Large Assortment of TRIMMINGS for Millinery Ornaments, Scarf Pins, etc

**For BADGES AND MEDALS**

Flag Pins, Class Pins, Class Rings  
and Special Work of all Descriptions.  
SEND TO **E. R. STOCKWELL,** MANUFACTURER  
19 John Street. New York

**OFFICES TO LET**  
IN THE  
**HAVEMEYER \* BUILDING.**

GOOD LIGHT AND SERVICE, ALL IMPROVEMENTS, FROM \$450 UP.

For particulars apply to

**W. B. DUNCAN,**

Office, 815 Havemeyer Building, N. Y.



### News Gleanings.

B. J. Burgoon has opened a repair shop in Du Bois, Pa.

W. J. Sager has opened a jewelry store in Horseheads, N. Y.

Ed. Meader will engage in the jewelry business in Marshall, Minn.

J. M. Nichols has removed his stock from Ithaca, Mich. to Alma, Mich.

Frank Lindacher, Canton, O., was recently married to Miss Rosie Volzer.

Henry Bohm, Denver, Col., has sold his residence to E. N. Bessee for \$15,000.

Henry Seeman has bought the jewelry store of Henry Saul, at Charter Oak, Ia.

Fred. L. Martin, Portsmouth, N. H., has removed to another location in that town.

Mr. Garman, Wilkesbarre, Pa., has moved from 336 Court St., to 445 Pine St.

G. H. W. Smith, Ware, Mass., has purchased F. L. Sturtevant's livery stable.

R. B. Loose, Atkinson, Neb., has been closed out on a chattel mortgage for \$1,800.

The entire stock of J. E. Tyler, Richmond, Va., has been sold to L. Friedman, New York.

Edward S. Brown, Malden, Mass., has given up business and will return to Waltham.

Henry Forbes will start a jewelry business in Portage, Wis., about the middle of this month.

Morton Wilson will open a jewelry store on the site of that of his former employer, in Auduron, Ind.

Executions amounting to \$772 were issued Thursday against Jas. H. Cunningham, Fairfield, Pa.

H. M. Senior's Holyoke store was entered a short time ago and the thieves secured a quantity of jewelry.

J. Grieger, Amsterdam, N. Y., will take a trip this Spring to Austria where he will remain four months.

Arthur Stevens, Whitman, Mass., is going west to locate, and M. W. Garfield will be his successor in Whitman.

The death occurred on Feb. 5 of Mrs. Nancy M. Richmond, mother of jeweler L. L. Richmond, Meadville, Pa.

The men who robbed J. Rowinski, Savannah, Ga., about two weeks before Christmas, have been captured.

A. D. Harlow who runs jewelry stores in Bangor, Orono and Winterport, Me., has closed his establishment in Bangor.

Charles B. Coffin, Ovid, Neb., has bought out the business of A. E. Case, Greeley, Neb. L. Russell will manage the store.

Denney Bros., Portland, Ind., are having a new floor put in their business room. The firm will occupy hereafter the entire store.

The jewelry store of A. Bank was badly damaged by water during the fire in the Boston Store, Omaha, Neb., a few days ago.

W. C. Bryant, successor to John Tibbetts & Co., Bangor, Me., offers a prize of \$10 in gold for the best design for a Bangor souvenir spoon.

W. E. Beard, formerly of Reading, Mass. who went west a few years ago, has returned to that town, and started in business again.

John Bonnet, R. S. Mershon and H. P. Lindsay have been appointed appraisers of the stock of jewelry assigned by Mrs. Tanner, Zanesville, O.

G. W. Kennedy, of Chicago, has leased the store at 502 Walnut St., Des Moines, Ia., and has opened with a line of jewelry, diamonds, art goods and bric-à-brac.

The Anderson Jewelry Co., Rockford, Ill., have incorporated with a capital stock of \$3,000; incorporators, A. John Anderson, E. R. Walborg, and Samuel G. Johnson.

The Tuttle-Dugan Jewelry Co., of Butte, Mon., have incorporated with a capital stock of \$20,000. The promoters are. H. S. Tuttle, E. O. Dugan and John W. Cotter.

J. C. Broghammer, jeweler, Wilkesbarre, Pa., has bought the fixtures, etc., of Davidow Bros., and will occupy that store, in conjunction with a tailor, after April 1st.

Last week Henry Mettler, Louisville, Ky., from whose jewelry store James Smith stole four watches and was arrested in New Albany, sent \$40 to the officers for making the arrest.

The Rockford Watch Co.'s factory employes were notified last week that work would be provided for them eight hours a day, Tuesdays, Wednesdays and Thursdays of each week.

Axiom Overman's jewelry store, Campbellsburgh, Ind., was entered by burglars last Tuesday night, who blew open the safe and stole jewelry and money aggregating in all nearly \$1,000.

J. H. Teal, jeweler, Scranton, Pa., has succeeded his uncle, the late George W. Miller, in the insurance business which the latter conducted. He has also been appointed a notary public.

Wednesday morning burglars entered the hardware store of Fish & Kronenberg, Hamburg, N. Y., through a rear door and succeeded in carrying off between \$500 and \$600 worth of silverware.

The following named jewelers have found employment with the International Mfg.

Co., Iowa City, Ia.: Judd Custer, Milan, Mo.; D. A. Marsh, Spencer, Ia.; C. M. Rockwell, Ludinham, Mich.

George E. Whitman, 290 W. Ferry St., Buffalo, N. Y., on Feb. 6th assigned everything he had to Chas. W. Stuart. Clara A. Whitman, who loaned him \$150 Feb. 1, 1894, is the only preferred creditor.

Edwin Keller, Allentown, Pa., on the 1st inst., took his son, Herbert P. Keller, into partnership with him, and the firm is now known as E. Keller & Son. The young man has been brought up in the business.

It is reported from Yuma, Ariz., that Col. George A. Allen, an old pioner, a few weeks since, found an opal mine in Yuma County, sixty miles north of Yuma. He left last week with "a good sackful" for the Midwinter Fair in San Francisco.

The case of Benajah Williams, ex-president of the DuLaney Clock Co., Valparaiso, Ind., who was indicted for conspiracy to commit a felony, as reported in THE CIRCULAR last week, will be tried in March. Motion to quash the indictment was overruled.

A keeper has been placed in Albert Lusson's second hand jewelry store, 140½ Front St., Worcester, Mass. His store was attached on a writ in favor of the Suffolk Supply Co, of Boston for \$300, and John J. McGratty was placed in charge of the place as keeper.

The board of trade of Batavia, N. Y., has received a communication from a man in Lyons who wants to go to Batavia to manufacture silver plated hollow ware with a paid up capital of \$10,000 and bring 15 skilled workmen and employ 25 Batavia men. He asks for a building and power.

That artistic designs may be embodied as prominently in the plated as in the solid ware, is forcibly shown by the latest pieces in hollow ware, napkin rings, etc., introduced by the Adelphi Silver Plate Co., 62 John St., New York. Some of their new fancy and rich repoussé designs particularly show the great strides made in this industry toward the production of articles which shall be in the fullest sense things of beauty as well as of utility.

The jeweler who seeks expensive and medium priced watches, split seconds and repeaters should be happy in the knowledge that his search will not prove in vain. It is well known to the trade that A. Wittnauer, 19 Maiden Lane, New York, carries a complete line of imported movements in various grades fitting American cases of all sizes. He also makes a specialty of genuine finished watch material for Agassiz and Longines movements.



The Roy Watch Case Co. Cases are  
Sold only through Jobbers.

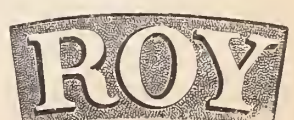



## Our Traveling Representatives



Traveling representatives may consider these columns open for the publication of any news or items of interest regarding themselves or their conferees.

**R.** W. BARLOW, representing C. H. Knights & Co., in Illinois, Missouri and Indiana, C. A. Garlick in Iowa and Nebraska, and T. J. Bristol in Wisconsin, Minnesota and Dakota left Feb. 5th

for their respective territories.

E. E. Spalding, with Lapp & Flershem, is in from his early Spring trip in the north-west.

E. D. Gallagher and O. Derndinger, representing C. H. Knights & Co.'s material department, left for the road Wednesday.

Paul Shorediche returned to Chicago to replenish his lines from Lapp & Flershem's latest novelties and staples.

H. W. Rowell has accepted a position as traveler for the wholesale jewelry establishment of W. F. Main Co., Iowa City, Ia.

Col. Nels Davis, with B. S. Freeman & Co., left Chicago for the east Wednesday and frankly affirms he had a fair business on his entire trip.

Abel King sailed for Europe Tuesday Feb. 6th on the *Elbe* in search of novelties. He is well known to the trade owing to his long connection with I. Emrich & Co.

Genial Riley Weeks, who for the past ten years has been in the employ of W. W. Mansfield & Co., Portland, Me., as salesman, has been engaged by C. G. Alford & Co., New York, and will travel in Maine in their interest.

The following traveling men visited the wholesale jewelers of Kansas City, Mo., last week: O. R. Ryan, Towle Mfg. Co.; C. A. Boynton, Wm. B. Kerr & Co.; E. C. Holbrook for Frank W. Smith; I. S. Adler, Seth Thomas Clock Co.; Lou. Fay, Kirby, Mowry & Co.

Few eastern travelers are left with the Chicago trade. These include Chas. W. Hempel, Sandland Capron & Co.; Chas. M. Robbins, Mason & Robbins; Chas. Whiting, Wade, Davis & Co.; R. A. Thompson, for Henry Glorieux; Mr. Metcalf, R. Blackinton & Co.; F. F. Fessenden, Fessenden & Co.; David N. Smith, Wm. Smith & Co.; Chas. J. Fox, M. Fox & Co.; Nels Davis, B. S. Freeman & Co.

Traveling men calling on Davenport, Ia., jewelers the past week were: Alfred Auer-

bach, Auerbach & Barnett; C. P. Bartlett, Whiting Mfg. Co.; Wm. Weidlich, Waterbury Watch Co.; J. H. McCormick, Waterbury Clock Co.; R. L. Robinson, Dennison Mfg. Co.; C. A. Garlick, C. H. Knights & Co.; H. M. Tenney, Lapp & Flershem; E. L. Coggeshall, Rogers, Smith & Co.; C. A. Barnum, Meriden Britannia Co.; E. A. Reed, Reed & Barton.

The following traveling salesmen passed through Detroit last week: F. H. Sterling, Parsons & Greene Co.; Luther Hyde, Reed & Barton; Leon Bloch, L. D. Bloch & Co.; Arthur S. Holly, Towle Mfg. Co.; Frank T. Sloan, John A. Riley & Sloan Co.; H. B. Davis, Middletown Plate Co.; M. D. Rothschild; W. C. Coombs, E. F. Sanford & Co.; Mr. Braillard, Braillard & Pfingsten; Robert Welch, Welch & Miller; D. H. Lowman, Lissauer & Co.; C. A. Cuppia, Ludwig, Redlich & Co.; B. L. Moorhead, Moorhead & Co., and Ed Blake, Barden, Blake & Co.

Traveling men who visited the Boston trade last week included: E. L. Spencer, E. L. Spencer & Co.; F. V. Kennion for J. T. Maura; Mr. Ripley, Watson, Newell & Co.; E. A. Woodmancy, Potter & Buffinton; W. H. Taftton, Wightman & Hough Co.; Joseph Fowler Fowler, Bros.; S. O. Bigney, Marsh & Bigney; Fred Clarkson, Snow & Westcott; Hugo Citroen, Vve. L. B. Citroen & Co.; G. B. Osborn, Wm. Smith & Co.; C. W. Cary, J. B. & S. M. Knowles Co.; H. B. Beach, Wilcox Silver Plate Co.; H. W. Dunham, Meriden Silver Plate Co.; Chris Morgan, Rogers & Bro.; Charles L. Power, Ludeke & Power; and Samuel Stern.

Travelers in Pittsburgh, Pa., last week were: Frank C. Welsh; C. E. Settle, Hopkins & Settle; Ned Eaton, Albro, Eaton & Co.; Wm. Woods, Dominick & Haff; Mr. Middlebrook, B. A. Ballou & Co.; Luther Hyde, Reed & Barton; Mr. Metcalf, R. Blackinton & Co.; W. McDonald, Courvoisier-Wilcox Mfg. Co.; Harry Osborne, Whiting Mfg. Co.; Samuel Howland, Eisenmann Bros.; Charles Ketcham, Riker Bros.; E. T. Hopkins, Meriden Silver Plate Co.; Jos. Beach, Wilcox Silver Plate Co.; Wm. Copeland, Martin, Copeland & Co.; Dick Robinson, Richard Robinson & Co.; E. Macdonald, Sandland, Capron & Co.; H. W. Sowade N. Glauber & Co.; W. R. Shute, Day & Clark; A. B. Daggett, Derby Silver Co.; W. R. Cobb, W. R. Cobb & Co.; E. L. Mumford, Waite, Thresher Co.

Among the travelers favoring the Syracuse, N. Y., trade with a call the past ten days were: Mr. Brown, G. H. Cahone & Co.; W. M. Clements, Waterbury Clock Co.; A. N. Dorchester, Kent & Stanley Co.; Harry C. Larter, Hayden W. Wheeler & Co.; Max Traub, Herzog, Goldsmith & Frank; F. M. Neefus, E. N. Welch Mfg.

Co.; F. W. Bliss, Unger Bros.; M. Adler; Major Brooks, Brooks & Pike; Mr. Horton, J. B. Bowden & Co.; Chas. E. Bride, S. Cottle Co.; Mr. Davidson, Harrison Bros. & Howson; F. C. Allen, A. Wittnauer; Col. L. Stevens, Jr., Keller & Untermeyer Mfg. Co.; B. C. Crandall, Crandall & Pardee; W. C. Tappan, D. F. Briggs Co.; B. A. Noble, Payton & Kelley; W. A. Davidson, Hipp Didisheim & Bro.; Sam. Cohn, Oppenheimer Bros. & Veith; Ernest Block, W. & S. Blackinton; C. A. Whiting, Wade, Davis & Co.; Edgar L. Brown, for Manasseh Levy; A. M. Stevens, H. Muhr's Sons; Mr. Friedman, Fidelity Watch Case Co.; J. Robinson, Holden & Knox; Mr. Simons, Stern Bros. & Co.; Mr. Franklin, L. Tannenbaum & Co.; Rudolph Noel, for R. A. Breidenbach; M. C. Wells, Pierce & Gardiner; Lorenzo Van Allen; J. Rathbone; W. H. Payson, J. W. Grant & Co.; Leon Schwab, New Haven Clock Co.; F. C. Platt, Foster & Bailey; E. L. Mumford, Waite, Thresher Co.; Nat Durlach, Durlach Bros.; Henry M. Tallman, Irons & Russell.

### Canada and the Provinces.

L. Lewis, jeweler, Walford, Ont., is offering to compromise with his creditors.

The store of T. N. Ricard, Bowmanville, Ont., was damaged by fire last week to the extent of \$500.

T. O. Grothe, N. Lawrence, Main St. Montreal, was elected member of the city council last week, by a substantial majority over his opponent.

On Feb. 7th the Windsor, Ont., police arrested three boys on a freight train and found a large quantity of jewelry and \$50 in five-cent and ten-cent pieces. It is not yet known where they got the plunder.

S. Eastwood, jeweler, New Glasgow, N. S., has returned from New York, where he successfully passed graduation examinations in optics. He will continue his business in New Glasgow.

The marriage took place at Pictou, N. S., on the 5th inst., of F. J. Tobin, of Aston & Tobin, Truro and Pictou, and Miss Mary McDonald, of Pictou. W. A. Aston, of Truro, will have charge of the business in Pictou during Mr. Tobin's absence on his wedding tour.

Thomas Bowden, Toronto, Ont., brought an action against the Canada Plating Co., of Montreal, for \$600, the amount of the alleged contract by which the company was to purchase 5,000 street car ticket boxes from W. H. Scott. The latter assigned his right to manufacture the same to Thomas Bowden. The company rescinded the contract. The suit was tried at Toronto last week and the action was dismissed.

# ROY

The Roy Watch Case Co. Cases  
assay among the highest.

# ROY



# A NEW DEPARTURE IN WATCHMAKING.

## THE CHARMILLES WATCH

OPEN FACE, STEM WINDING, PENDANT SETTING, 16 SIZE, 3-4 PLATE, SOLID NICKEL MOVEMENT, 7 JEWELS, STRAIGHT LINE LEVER ESCAPEMENT; CASED IN NICKEL AND STEEL, PLAIN AND ORNAMENTED.



NO. 5, NICKEL, OLD SILVER FINISH, APPLIED DESIGN.



NO. 1, NICKEL, PLAIN POLISHED.



NO. 4, NICKEL, OLD SILVER FINISH.

**GUARANTEED  
PERFECT  
TIMEKEEPERS.**

THE advent of the "CHARMILLES" marks a new era in the construction of watches. Heretofore the "movement" and "case" have been two distinct and separate pieces. In the "CHARMILLES" watch they are one and the same thus permitting a HIGHER QUALITY MOVEMENT at the expense of the case. The stem-winding and pendant hand setting mechanism is extremely simple, durable and positive, and is a feature of the watch. The "CHARMILLES" is not a cheap watch, but a finely finished nickel movement, cased in its simplest form, and sold at a LOW PRICE.

Practical watchmakers are delighted with its construction and practical advantages, and watch merchants charmed with its appearance and selling points. No low-priced watch in the market can compare with the "CHARMILLES." It is the watch of the times—the greatest value for the least money.

**THOROUGHLY  
NON-MAGNETIC.**



NO. 7, STEEL, BLACK OXYDIZED, SILVER DESIGN.

For Sale by leading Jobbers and carried by progressive traveling salesmen. Write your jobber for a sample or inquire of traveling salesmen.

**DO NOT BE WITHOUT THEM.**



NO. 8, STEEL, BLACK OXYDIZED, GOLD DESIGN.

# CLASSIFIED INDEX TO ADVERTISEMENTS.

All Advertisements are entitled to one insertion under proper heading. Extra insertions, \$6.00 per annum.  
Extra Headings, \$12.00 per annum.

Page.		Page.		Page.
	<b>Art Pottery, Bric-a-brac, Etc.</b>		<b>Horological Schools.</b>	
	Bing, Ferdinand & Co., 106 Grand St., N. Y. . . . . 38		American Horological Institute, Lancaster, Pa. 22	
	Borgfeldt, Geo. & Co., 18, 20 & 22 Washington Place, New York. . . . . 41		Chicago Watchmakers' Institute, Chicago, Ill. 20	
	Healey, M. & E., Washington, D. C. . . . . 42		Elgin Horological School, Elgin, Ill. . . . . 23	
	Hirrichs & Co., 29 & 31 Park Place, N. Y. . . . . 43		Parson's School for Watchmakers, Peoria, Ill. 23	
	Straus, L. & Sons, 42 to 48 Warren St., N. Y. 37			
			<b>Hotels.</b>	
	<b>Assayers &amp; Refiners.</b>		Gibson House, Cincinnati, O. . . . . 20	
	Clark, J. L., Philadelphia, Pa. . . . . 40			
	Howard, S. P., 33 Maiden Lane, N. Y. . . . . 44		<b>Jewelers' Findings.</b>	
	Schawel, J. & Co., 29 John St., N. Y. . . . . 44		Lind, Thos. W., Providence, R. I. . . . . 28	
	<b>Auctioneers.</b>		<b>Jewelry Mailing Boxes.</b>	
	American Syndicate of Jewelry Auctioneers, New York and Washington. . . . . 2		Am. Railway Supply Co., 24 Park Place, N. Y. 40	
	Comrie, 182 Broadway, N. Y. . . . . 7			
	Prince, J., 137 Broadway, N. Y. . . . . 44		<b>Jewelry, Silverware and Optical Cases.</b>	
	Scott, De B. O., 20 Murray St., N. Y. . . . . 43		Jackson, S. C., 180 Broadway, N. Y. . . . . 7	
			Steinhaus, Theo. C., 10 Maiden Lane, N. Y. . . 33	
	<b>Badges, Medals, Etc.</b>			
	Irons & Russell, Providence, R. I. . . . . 7		<b>Jobbers, Watches, Diamonds, Etc.</b>	
	Schlechter, G. A., Reading, Pa. . . . . 26		Brethauer Watch and Jewelry Co., Chicago, Ill. 50	
	Stockwell, E. R., 19 John St. N. Y. . . . . 28		Cross & Beguelin, 17 Maiden Lane, N. Y. . . . 2	
	Willson, Chas. G., Reading, Pa. . . . . 16		Myers, S. F. & Co., 48 Maiden Lane, N. Y. . . . 44	
			Oppenheimer Bros. & Veith, 35 Maiden Lane, N. Y. . . . . 25	
	<b>Clocks, French, English and American.</b>		<b>Leather and Silver Goods.</b>	
	Jacques, Chas., Clock Co., 22 Cortlandt St., N. Y. . . . . 44		Deutsch Bros., 7 E. 17th St., N. Y. . . . . 2	
	<b>Diamond Cutters and Importers.</b>		<b>Musical Boxes.</b>	
	Humphrey, J. B., Boston, Mass. . . . . 26		Jacot & Son, 298 Broadway, N. Y. . . . . 2	
	<b>Diamond &amp; Precious Stone Importers.</b>		<b>Miniature Photographs.</b>	
	Disselkoen, John N., 19 E. 16th St., N. Y. 27		Favre, Leon, 107 E. 26th St., N. Y. City. . . . 26	
	Eichenberg, Julius, Providence, R. I. . . . . 26			
	Falkenau, Oppenheimer & Co., 40 Maiden Lane, N. Y. . . . . 44		<b>Optical Goods.</b>	
	Hedges, Wm. S. & Co., 170 Broadway, N. Y. . . 26		Berger, Albert & Co., 47 Maiden Lane, N. Y. . . 38	
	Kipling, R. A., Hays Bldg., N. Y. . . . . 26		Geneva Optical Co., Chicago, Ill. . . . . 25	
	Randel, Baremore & Billings, 29 Maiden Lane 27		Kirstein's, H. E., Sons Co., Rochester, N. Y. . . 43	
	Smith, Alfred H. & Co., 182 Broadway, N. Y. . . 26		Laurencot, Jules, 49 Maiden Lane, N. Y. . . . 4	
	Tannenbaum, L., & Co., cor. Maiden Lane and Nassau St., N. Y. . . . . 15		The Nouse Verons Co., Boston, Mass. . . . . 35	
			Queen & Co., Philadelphia, Pa. . . . . 8	
	<b>Engraving Machines.</b>		<b>Office Building.</b>	
	A. E. Francis, Cleveland, Ohio. . . . . 21		Cruijkshank, E. A. & Co., 176 Broadway, N. Y. 24	
			Diamond Exchange Building, 14 Maiden Lane. 8	
	<b>Fine Stationery.</b>		Duncan, W. B. J., 815 Havemeyer Building, N. Y. . . . . 28	
	Parsons & Greene Co., 18 Murray St., N. Y. . . 5			
			<b>Paneled Metal.</b>	
	<b>Gold and Silver Plating Works.</b>		Northrop & Co., Pittsburgh, Pa. . . . . 42	
	Bolstad Mfg. & Plating Co., Chicago, Ill. . . . 23			
			<b>Paper Boxes.</b>	
	<b>Gold Jewelry.</b>		Warner Bros., Bridgeport, Conn. . . . . 38	
	Carter, Sloan & Co., 15 Maiden Lane, N. Y. . . 27			
	Johnson, R. M., 67 Washington St., Chicago, Ill. 23		<b>Pens, Pencil Cases, Etc.</b>	
	Kremetz & Co., 182 Broadway, N. Y. . . . . 2		The Boston Pen Co., Boston, Mass. . . . . 4	
	Pfeil, Chas. H., Chicago, Ill. . . . . 23			
	Street, Geo. O. & Sons, 15 John St., N. Y. . . . 2		<b>Patents.</b>	
	Unger Bros., 192 Broadway, N. Y. . . . . 10		Belt, C. T., Washington, D. C. . . . . 25	
	Webster, G. A., Chicago, Ill. . . . . 23			
			<b>Platinum Importers.</b>	
	<b>Gold and Rolled Plate Jewelry.</b>		Schawel, J. & Co., 29 John St., N. Y. . . . . 44	
	Foster & Bailey, Providence, R. I. . . . . 11			
	Read, M. L. & Co., Providence, R. I. . . . . 9		<b>Ring Makers.</b>	
	Smith, Wm., & Co., 5-7 Maiden Lane, N. Y. . . . 44		Bryant, M. B. & Co., 10 Maiden Lane, N. Y. . . 44	
			Bowden, J. B. & Co., 192 Broadway, N. Y. . . . 7	
			Hildreth Mfg. Co., 51 Maiden Lane, N. Y. . . . 42	
			<b>Rubber Stamps and Type.</b>	
			Dietz, Wm. H., Chicago, Ill. . . . . 19	
			<b>Sample Trunks.</b>	
			Crouch & Fitzgerald, 161 Broadway, N. Y. . . . 43	
			<b>Silver Mounted Ebony Goods.</b>	
			Deutsch Bros., 7 E. 17th St., N. Y. . . . . 2	
			<b>Silver Plated Ware.</b>	
			Adelphi Silver Plate Co., 62 John St., N. Y. . . 17	
			Pairpoint Mfg. Co., New Bedford, Mass. . . . . 5	
			Rogers & Bro., 16 Cortlandt St., N. Y. . . . . 3	
			The Holmes & Edwards Silver Co., Bridge- port, Conn. . . . . 8	
			<b>Sterling Silverware.</b>	
			Campbell-Metcalf Silver Co., Providence, R. I. 44	
			Knowles, J. B. & S. M. Co., Silversmiths' Hall, Union Square, N. Y. . . . . 7	
			Reed & Barton, 37 Union Square, N. Y. . . . . 19	
			Shiebler, Geo. W., Co., 179 Broadway, N. Y. . . 4	
			Towle Mfg. Co., Newburyport, Mass. . . . . 42	
			Wallace, R. & Sons Mfg. Co., 3 Park Place, 6	
			Whiting, F. M., North Attleboro, Mass. . . . . 9	
			Wood & Hughes, 10 John St., N. Y. . . . . 43	
			<b>Spectacle and Eyeglass Cases.</b>	
			Birmingham, Wm. & Co., 728 Arch St., Phila.. 20	
			White, W. B. & Son, Boston, Mass. . . . . 33	
			<b>Stem Winding Attachments.</b>	
			Abbott, Henry, 2 Maiden Lane, N. Y. . . . . 10	
			<b>Show Cases.</b>	
			Smith, B. & W. B., 220 W. 29th St., N. Y. . . . 44	
			<b>Tortoise Shell Goods.</b>	
			Potter, W. K., Providence, R. I. . . . . 43	
			<b>Tool Manufacturers and Dealers.</b>	
			American Watch Tool Co., Waltham, Mass. . . 43	
			Bullock, O. W. & Co., Springfield, Mass. . . . . 4	
			Gesswein, F. W., 39 John St., N. Y. . . . . 38	
			Hardinge Bros., Chicago, Ill. . . . . 20-21	
			Logan, A. J., Waltham, Mass. . . . . 42	
			Moseley & Co., Elgin, Ill. . . . . 20	
			Oliver, W. W., Buffalo, N. Y. . . . . 22	
			<b>Trunks and Traveling Bags.</b>	
			Crouch & Fitzgerald, 161 Broadway, N. Y. . . . 43	
			<b>Watch Manufacturers.</b>	
			Charmilles Watch, N. Y. . . . . 31	
			Durrstein & Co., Germany. . . . . 38	
			<b>Watch Case Manufacturers.</b>	
			Illinois Watch Case Co., Elgin, Ill. . . . . 40	
			Margot Bros., Boston, Mass. . . . . 40	
			Roy Watch Case Co., 21 Maiden Lane, N. Y. . . . . 29, 30, 34	
			The Planchamp & Becker Co., Chicago, Ill. . . 23	
			Wadsworth Watch Case Co., Newport, Ky. . . . 21	
			<b>Watch Dials</b>	
			O'Hara Waltham Dial Co., Waltham, Mass. . . 25	
			<b>Watchman's Clocks.</b>	
			Hausburg, O. E., 41 Maiden Lane, N. Y. . . . . 33	
			<b>Watch Importers.</b>	
			Hyde's, J. E., Sons, 22 Maiden Lane, N. Y. . . 44	
			Mathey Bros., Mathez & Co., 21 & 23 Maiden Lane, N. Y. . . . . 24	
			<b>Watch Keys.</b>	
			Clark, A. N., Plainville, Conn. . . . . 2	
			<b>Watch Repairers.</b>	
			Muller, Hugo, Chicago, Ill. . . . . 23	



## Special Notices.

Rates 75c. per insertion for notices not exceeding 3 lines (25 words), additional words 2 cents each. If answers are to be forwarded, postage stamps must be enclosed. Two insertions, 15 per cent. off; three insertions, 20 per cent. off; four insertions or more, 25 per cent. off. Payable strictly in advance. Display cards on this page will be charged at \$2.00 per inch for first insertion, subject to same discount as above for subsequent insertions.

Under the heading of **Situations Wanted** on this page advertisements will be inserted for **One Cent a Word**. This offer refers to **Situations Wanted only**. Payable strictly in advance. If answers are to be forwarded, postage must be enclosed.

## Situations Wanted.

Notices under this heading **ONLY** are charged at one cent a word, payable strictly in advance. If answer are to be forwarded, postage must be enclosed.

**A JEWELER** wants position with a wholesale or retail store, to take charge of shop, making and repairing. Address Metallurgist, care **JEWELERS' CIRCULAR**.

**WANTED**, a position in factory or as traveling salesman by a gentleman of 25 years' experience in the plain gold ring business. Address "H," care of **JEWELERS' CIRCULAR**.

**SITUATION WANTED** by watchmaker and jeweler; young man; three years' experience; best of references. Address W. A. Babcock, Walnut, Ill.

**POLISHER**, first class on rings and jewelry, desires position. Address M. Diehl, 41 East Fourth St., New York City.

**WANTED, SITUATION**—Manager of a business for two years past. Do all branches of work—watchmaking, engraving, seal making, jobbing, selling, buying. Box 695, What Cheer, Ia.

**POSITION** wanted by young man as assistant entry clerk. Unquestionable references. Address "W. C.," care **JEWELERS' CIRCULAR**.

**SITUATION WANTED** by watchmaker who thoroughly understands his business. Competent on chronographs and French clocks. Does all kinds of jewelry repairing. Good salesman. Address "Energetic," care **JEWELERS' CIRCULAR**.

**SALESMAN**.—Young man 23 years, wants position; acquainted with wholesale and retail jewelry trade; salary moderate. A. L. H., care **JEWELERS' CIRCULAR**.

**SITUATION** wanted by young man as engraver and assistant watchmaker; can give sample of work and good references. Address O. Grospietsch, care C. B. Jacquemin & Co., Council Bluffs, Ia.

**YOUNG MAN**, single, age 23, wishes situation either in Maryland, W. Virginia, Virginia, North or South Carolina, or Georgia, as watchmaker, jewelry jobber and plain engraver. Sample of work furnished. Good references. Address Southern, care **JEWELERS' CIRCULAR**.

**GOOD WATCHMAKER**, capable of doing all work, such as comes to a first class store, and who can take entire charge. American; age 36 years; married. Owns tools and bench. New England preferred. Permanent place desired, with a square dealing man. Address F & A. M., care of **JEWELERS' CIRCULAR**.

**WATCHMAKER**, who has had 13 years' experience at bench, wants a steady situation. Can do any kind of repairing and jobbing, or will take charge of jewelry stock. Can give A1 references. Address Lock Box 756, Eureka Springs, Ark.

**GOOD ENGRAVER**, age 25, can repair clocks and watches. Will send sample of engraving. Best of references. Address D. T., care **JEWELERS' CIRCULAR**.

## To Let.

**BROADWAY STORE**, near Post Office. Half store and one window. Lease. 2 Astor House, New York.

**TO LET**.—A large office, 20 x 40, first floor, No. 11 Maiden Lane. \$60 a month.

## Miscellaneous.

**I BUY JEWELRY STOCKS**—Manufacturers, jobbers and retailers desiring to dispose of surplus or entire stocks of diamonds, watches and jewelry can find quick cash buyer by addressing Stephen S. Harmon, 134 East 96th St., New York City.

### DEMAGNETIZING.

**PERFECT WORK**—Watch repairing in all its branches; all work warranted. Winslow & Penney, 608 Masonic Temple, Chicago.

**FOURTEEN karat gold solder** that will flow on eight karat work; makes a hard solder job a pleasure. With this solder there is no danger of melting low karat specs. No white joints on rings. It is just what you want. Sample by mail 25 cents. F. W. Hall, Sterling Silver Novelties, Columbus Memorial Building, Chicago, Ill.

**SEND** for new 1894 prospectus of Trowbridge's Engraving School. Lowest terms of any school. Board \$12 to \$15 per month. Winona, Minn.

**COMPLETE** instructions how to conduct legal watch and jewelry clubs for \$2. A new system by which jewelers can largely increase their sales. Address The O. S. Judd Jewelry Co., Anderson, Ind.

**WANTED—PARTNER** with \$3,000 to \$4,000 to assume half interest in old established jewelry and stationery business. The leading store in a fast growing town; population 6,000. Am satisfied business can be increased with a live partner. Want a thorough business man, and would prefer an engraver and optician. The other part of the business I understand thoroughly. Every facility for investigation will be given. Call or address A. F. Robbins, Orange, Mass.

**ENGRAVING MACHINE**, also optometer for watches, or anything I can use. Address W. A. Sherwood, care **JEWELERS' CIRCULAR**.

**FOR EXCHANGE**—I have a city lot, a business location and cash to exchange for general stock of watches, jewelry and silverware and set of trial lenses. Address with stamp, H. T. Bramer, Attica, New York.

## For Sale.

**FOR SALE**.—A first class polishing lathe; all in good repair, at a low price for cash. Address G. W. Brown, 113 Point St., Providence, R. I.

**FOR SALE**—A nice jewelry store in a town of 25,000; best location; small stock; low rent; 30 miles from New York. About \$3,000,—can reduce to \$2,000 or less. Owner has other business. A bargain. Address "Bargain," care **JEWELERS' CIRCULAR**.

**MUST BE SOLD AT ONCE**.—Handsome jewelry store in city of 20,000. Antique oak horse-shoe cases, regulated to match. Silver bronze burglar-proof safe. Stock reduced to a few staple articles. Easy terms if sold soon. A. C. Barry & Co., Danbury, Conn.

**FOR SALE**.—Whitcomb 1 1/2 lathe, hand, with attachments. In perfect condition. Sold for want of time. Cash, at half price. For list of tools and particulars, address Wm. Gibbs, Helena, Mont.

**FOR SALE**.—Marvin book safe, nearly new, for sale cheap. Outside doors swing around to side, for use under hand desk. Inside doors have lock. Can be seen at 19 Maiden Lane, on application to S. B. Mann or Cephas Brainerd, assignee of Chas. S. Crossman & Co., 47 Cedar St., New York.

**FOR SALE**—Two good jewelry stores, 30 and 20 miles from New York. One established 35 years, only one in 10 miles; carry a decent stock; village of 4,000. Will reduce stock or discount valuation. Address Bonanza, care **JEWELERS' CIRCULAR**.

**TO A RUSTLER—FOR SALE**—Clean stock of watches, clocks and jewelry; one polishing lathe; watch-rack, oak bench and one 8-foot show case and trays; small stock of material; all will invoice for \$510. Have had a jeweler since Oct. 4, 1893. Cash receipts for jeweler from Oct. 4, '93, to Jan. 27, '94, \$589.60; cash receipts from watch and jewelry repairing from Oct. 4, 1893, to Jan. 27, 1894, \$234.20. The work has averaged \$14.65 per week, and can be increased 50 per cent. when business revives.

The above stock is in Armour, S. Dak., one of the best business towns in the Northwest; population, 800 situated at the terminus of the Tripp Branch of the C. M. & St. P. R. R. Rich farming and live stock country, 120 miles north and west of Sioux City, Ia. Draws trade from 25 to 50 miles around, being the nearest railroad point; also within 3 1/2 miles of the Yankton Sioux Reservation, which is expected to be opened this Spring.

Will rent to purchaser, window, wall cases, lights, fuel and advertising for \$10 a month, in my drug store. Purchaser must be of good appearance and habits, and who will be prompt with his work. Will give him a long lease, and do all I can for his success. Terms cash, or A1 bank paper at 10 per cent. interest. Want purchaser here by Feb. 25, 1894. Address with stamped envelope, The Farmers' Drug Store, Owen D. Tibbetts, Armour, S. Dak.

## FOR SALE

IN

## CHICAGO.

*An old established Retail Jewelry Business, on a very prominent corner in the business portion of the city. Fine Fixtures and a Clean Stock. A big bargain may be obtained, as owner wishes to retire.*

Address C. B. S., care **JEWELERS' CIRCULAR**.

## FACTORY AND OFFICE TO RENT FROM MAY 1ST.

Desirable office on first floor with factory on fourth floor. John St., between Broadway and Nassau St. Office, 25x40; factory 25x75. Both connected by elevator and speaking tube. Factory well lighted and ventilated by four high sky-lights. Steam power according to wants. Rent \$2,000, or factory alone \$1,000. Address A. B. care **JEWELERS' CIRCULAR**.

## TO LET.

One of the most desirable Offices

— IN THE —

## HAYS BUILDING, 21 and 23 MAIDEN LANE.

APPLY AT OFFICE OF THE BUILDING.

**Headquarters** FOR **ELECTRIC & PORTABLE Watchman's Clocks** Price, Complete \$10.00

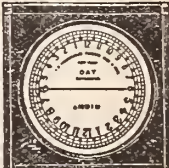

Lowest Prices. Latest Improvements. Patents 1888-1893. Send for Circular. **E. O. HAUSBURG,** 41 Maiden Lane, New York. **THE "ALERT."**

WHITE'S EYE SHADE. **W. B. WHITE & SON** MANUFACTURERS OF

**Spectacle and Eye Glass CASES** 90 SOUTH STREET, BOSTON.

Special Cases made to order for Optical Trade. Cases for Trial Lenses, Opera Glasses recovered, etc. Chatelaine Spectacle Cases, Metal Bound Leather Cases for combs, scissors, etc. Over forty kinds of cases manufactured.

## THEODORE C. STEINHAUS,

Late with Samuel C. Jackson for 26 years, as Manager 4 years,

— MANUFACTURER OF —

## Fine Cases and Trays

For **JEWELRY, SILVERWARE, &c.** **SAMPLE CASES AND TRAYS FOR TRAVELERS.**

Fancy Hard Wood Chests for Silverware, &c.

Office and Factory,

**10 MAIDEN LANE, NEW YORK.**



**The Latest Patents.**

ISSUE OF FEBRUARY 6, 1894.

**514,050. WATCH-HOLDER.** VEIT WESELY, Vienna, Austria-Hungary. Filed March 23, 1893. Serial No. 467,332. (No model.)

In combination the base plate having the fixed hook *b* on its front side, the right angular movable plate com-

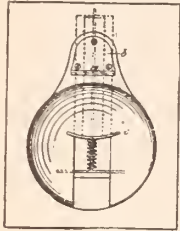

prising the hold fast, said base plate having front and rear cavities, the latter of which receives and guides the long arm of the right angular plate, the guide rod in said rear cavity passing through the end of the right angular plate and the spring arranged in said rear cavity encircling said rod and acting upon the right angular plate.

**514,427. HOLDER FOR TEA BALLS, STRAINERS, ETC.** JOHN S. PEABODY, Salem, Mass., assignor to John F. Simons, Frederick M. Simons and Edwin S. Simons, Philadelphia, Pa. Filed April 25, 1893. Serial No. 471,758. (No model.)



As an article of manufacture, a tea ball or strainer holder, consisting of a saucer shaped base *A* and a series of small arms *C* carried by the base and having their free ends extending upwardly and outwardly and provided on their extremities with balls or rounded portions *D* so that the extremity of each arm forms a point of support for the ball or strainer.

DESIGN **23,034.** KNIFE. JOHN T. CURRAN, Brooklyn, assignor to Tiffany & Co., New York,



N. Y. Filed Aug. 28, 1893. Serial No. 484,236. Term of patent 7 years.

DESIGN **23,039.** CANE-HANDLE. ANDREW



KROUSE, Bridgeport, Conn. Filed Dec. 28, 1893. Serial No. 495,011. Term of patent 3½ years.

TRADE MARK **21,159.** JEWELRY HAVING ARTIFICIAL-DIAMOND SETTINGS. SAMUEL BROS., Youngstown, Ohio. Filed Sept. 1, 1893.

Essential feature.—The word "VOLCANIC" within



a diamond shaped field. Used since April 1, 1893.

**Expired Patents.**

EXPIRED FEB. 6, 1894; GRANTED FEB. 6, 1877.

**186,912. FOUNTAIN-PENS.** JNO. M. MIGHT and C. W. H. TAYLOR, Toronto, Ontario, Canada.—Filed Aug. 15, 1876.

**186,987. CUFF-BUTTONS, STUDS, &c.** F. E. CAPRON, Providence, R. I.—Filed Dec. 4, 1876.

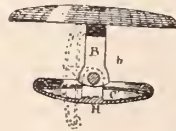

The combination of the shouldered stem *B B* with the disk *H* and disk-spring *C*.

**187,180. WATCH-GLASSES.** EDW. SCHLEGEL and W. SCHLEGEL, Boston, Mass.—Filed Oct. 22, 1875.



The combination of the watch or clock dial *B* with the crystal *A*, when the latter is furnished on one surface or both surfaces with a colored coating removed in portions.

**187,203. BUTTONS.** G. L. VOSE and A. S. SOUTHWICK, Providence, R. I.—Filed Sept. 30, 1876.

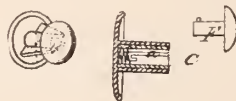

In combination with the tube *C*, having a longitudinal *L*-shaped slot, *a*, the tubular shank of the back plate, the cylindrical shank *F* of the face plate, having a locking-spur *i*, and the helical spring seated at the bottom of tube *C*.

REISSUE **7,189.** ANODES FOR ELECTRO-PLATING WITH NICKEL. A. HERMANN and W. H. TAYLOR, Stamford, Conn., assignors by mesne assignments to the Yale Lock Manufacturing Company, same place. Patent No. 166,367, dated Aug. 3, 1875.—Filed May 5, 1876.

**Newark.**

Bippert & Co. will remove their New York office to their factory, in the Lelong building, corner of Halsey and Marshall Sts., about April 1st.

E. P. Ledos, manufacturer of watch case materials, 118 Market St., was one of the victims selected by a gang of swindlers who have been operating in this city lately, but whose plans were frustrated by the police. Ledos was to make \$300,000 worth of notes, which were to be turned over to the swindlers, who would use them at a discount, in payment for goods purchased, Ledos to receive \$75,000 in cash. He was then to fail before the notes matured.

The subject of the abandonment of New York offices by Newark manufacturers has been again revived, and two more firms will shortly remove their business headquarters to this city. Kremetz & Co., who are now located at Broadway and John St., have nearly completed arrangements for the change, and will shortly occupy handsome offices in their factory building, corner of Mulberry and Chestnut Sts. Larter, Elcox & Co. will also give up their offices in the Hays building, 21 Maiden Lane, as soon as they can dispose of their lease, and remove to their factory in the Kremetz building, this city.

**St. Louis.**

A employes of the Mermod & Jaccard Jewelry Co. have contributed \$36.40 to the Lake Employment Fund.

A decrease of capital stock of the L. Bauman Jewelry Co. has been made from \$250,000 to \$160,000; assets \$351,536.30 and \$98,972.13 liabilities.

The Retail Jewelers' Association held their annual banquet last Thursday evening at Hussman's Café, 417 Franklin Ave. About 75 people were present. Charles Kroul responded to the toast "Our Guests," Otto Averbeck to "Organization," Kossuth Marx, "Tariff", and Gerhard Eckhardt "The Ladies." Among the guest were Sig. Goldsmith, of Adolph Goldsmith & Son; Jake and Kossuth Marx, of Kossuth Marx Jewelry Co., Louis Hirsch, of Lissauer & Co., and several others. President Herman Mauch presided in his usual graceful manner.

C. M. Meinhoefer, Allentown, Pa. is conducting an auction sale.

J. E. Van Laeys, Topeka, Kan., has purchased back the jewelry stock recently sold by him to Bernard Hothouse, and has opened up a store at 819 Kansas Ave.

The best Trade use the **ROY** Watch Case Co. Cases.



## Queries by Circular Readers.

*Editor of THE JEWELERS' CIRCULAR:*

Can you inform me where I can get any of the calendars that fit on the inside of watch cases. I think the Crescent Watch Case Co. used to print some.

JOHN HOOD.

ANSWER:—The Crescent Watch Case Co., 23 Maiden Lane, New York, will furnish the calendars you refer to upon application. The calendars for 1894 are not yet ready for distribution, but will be shortly.

*Editor of THE JEWELERS' CIRCULAR:*

At the Chicago Exposition in the Italian section there were quite a number of shell hair pins; one kind was all one color; a fine canary color or amber, and higher in price than the dark or mottled shell. Will you kindly state in your paper what the clear all yellow pins are made of and why they cannot be found in this country. They were beautiful.

SUBSCRIBER.

ANSWER:—If "Subscriber" had looked in the American Section, Gallery F, at the Fair, he would have found a magnificent display of American tortoise shell productions. See THE JEWELERS' CIRCULAR, May 3, 1893, front page. The amber part of shell comes partly from the toes, while the entire belly of a tortoise is amber color, but very thin, which makes it expensive. For further information write to Rice & Hochster, 485 Broadway, New York, principal manufacturers of tortoise shell goods in the United States.

*Editor of THE JEWELERS' CIRCULAR:*

Will you please state the method by which the green color is taken from the gold after soldering and pickling same? The new method is by electric motor; the old method in which a motor is not used is the one I would like to know.

M. S.

ANSWER: The usual jewelers' pickle is made of five parts water to one of sulphuric acid. When something is wanted that will "take hold" more than this a little hydrochloric or nitric acid is added to it. This pickle complies with all ordinary purposes, if the gold is not alloyed too much with copper. If the jeweler has trouble with a gold article, and it looks green or white (due to much silver), after having been in above pickle, make a pickle of strong sulphuric acid and saltpetre, equal parts, heat it boiling hot, hang the article on a hook made of copper wire, and dip into the boiling liquid; then wash. If the color is not good, repeat.

### James F. Cooper Charged With Misrepresenting the Value of His Store.

DENVER, Col., Feb. 6.—Kreider & Leiff have brought suit against James F. Cooper, for \$2,800 damages for alleged fraudulent representations made by the latter in regard to the value of a manufacturing jewelry establishment bought by the plaintiffs. It is charged that Cooper represented to them that the stock and business was unencumbered and worth fully \$2,500, whereas the fact was that there was a chattel mortgage upon it for \$1,000, which was foreclosed after the plaintiffs had given their note for \$2,500, the purchase price.

Several days ago Kreider had Cooper arrested on a criminal charge, making the same allegations.

## Some New Books.

THE PRACTICAL ELECTROPLATER by Martin Bruner. Emile Brunor, Publisher, 93 William St., New York.

This book, as its introductory states, is "a comprehensive treatise on electroplating, with notes on ancient and modern gilding, and formulas for new solutions." Being a compendium including the history, theory and practice of electroplating, the volume will be not only prized as a work of reference, but will prove invaluable as an aid and guide to the electroplater.

The author, Martin Brunor, has made this subject the hobby of his life, and his book is the result of 20 years' unremitting research. The two hundred articles and formulas for solutions alone which the book furnishes, will prove of inestimable benefit to the trade. The working jeweler also will find in the chapters on Refining Sweeps, Refining Auriferous Metal, Recovering Jewelers' Waste, Testing Gold, Testing Silver, etc., information that will be invaluable to him.

In writing this work Mr. Brunor has incorporated articles especially prepared for the book by eminent scientific men who stand as the highest recognized authorities in the various branches on which their contributions treat. Among these are: Dr. Wm. H. Wahl, secretary of the Franklin Institute for the Promotion of Mechanic Arts, Philadelphia, to whom Mr. Brunor is indebted for the chapter on Platinum Plating; P. M. Furlong upon Electrotyping; J. Swinburne, on problems of Commercial Electrolysis; Prof. F. B. Crocker, Dr. S. S. Wheeler, Mr. Boby and others.

The work has been already enthusiastically received and Mr. Brunor has been the recipient of numerous testimonials from all branches of the trade, some assuring him that in many cases a single recipe is well worth the price of the book, which is

\$10. Especially warm in their praises are such well known platers as J. P. Bonnett and others. The work was originally written in French and was ably translated by John E. Jennings. The treatise is substantially bound in half brown leather, with dark green cloth sides, all edges trimmed and marbled to match marbled end papers. Altogether "The Practical Electroplater" is what it was intended to be, "a practical book for practical men, and will be found very helpful in any electroplating shop."

Edward W. Bok's article in the January *Cosmopolitan* on "The Young Man in Business" has been reprinted in a tasteful and handy booklet form by The Curtis Publishing Co., Philadelphia. To this reprint Mr. Bok has added some 14 pages of editorial matter answering "Three Uncertain Young Men."

### Springfield, Mass.

E. A. Whipple has leased a part of his jewelry store to a florist.

M. E. Stratton has again entered the world of business and has opened a watch repairing store, in the Cooley Hotel block.

F. A. Hubbard furnished a very handsome silver cup, which was given by the citizens of Ludlow to the football team of that town.

Word has been received that Schlem Fiel, who worked the flim-flam game on jeweler Robinson and served six months for it, has been sentenced to serve five years in one of New York State's prisons, for working the same game in Troy.

Nathaniel Saxton, aged 82 years, father of Charles S. Saxton, formerly a well-known jeweler, at one time employed in his son's store, died in this city last week, and his body was taken to Geneva, N. Y., for burial. He leaves a widow, his son Charles, and one daughter. Mr. Saxton was born in Saratoga, N. Y.

# THE WARREN EYE PROTECTOR.

(Patented Jan. 12, 1892, Feb. 21, 1893.)

SAVES THE EYES FROM **Dust, Wind, or Glaring Light.**

FOLDS, IN A COMPACT CASE, IS

**COMFORTABLE, DURABLE, WATER AND DUST PROOF.**

Its large field does not obstruct the sight. No brittle substance to endanger face under sudden blows. Oculists and Physicians recommend it.

**Travelers, Cyclists, Railroadmen, Horsemen, Motormen, Quarrymen,**

**PRONOUNCE IT INDISPENSABLE FOR MAN OR WOMAN.**

ASK YOUR DEALER FOR IT,

Colors, Clear, Smoke, Blue or Green. Black frames, 50c. Silver, 75c. Sent by mail on receipt of price. Manufactured solely by

**The Nours Verrons Company.** P. O. Box 3273,  
BOSTON, MASS



## Friction.

WITH that kind of dead beat escapement, says Robert Immisch, where the friction remains active throughout, as in duplex and horizontal watches, the gyration is, of course, much less, and here it is imperative that attention should be paid to a proper proportion of weight and diameter of the balance. In the case of a cylinder watch, no amount of change in the balance spring will make long and short vibrations equal, if these proportions are incorrect. The friction on the sides of the cylinder is a given factor, and must be turned to a proper account; the gyrations being small in themselves, the arc of escape bears a large proportion to the whole extent of the vibration. During this arc of escape there is no side pressure against the cylinder, and a stronger impulse will consequently propel the balance forward with a greater velocity. This increase during the arc of escape in a properly constructed watch will be compensated for by the increased friction on the cylinder.

If a balance is too small and too heavy it is clear that its greater momentum will overcome this friction easier, and so neutralize the equalizing effect it would otherwise have had. It follows, if a cylinder watch gains with increased motive force, the balance is too small and too heavy. By making it lighter and putting in a weaker spring, a change is certainly effected in the right direction; but as any change in the motive force will beat too great a proportion to the absolute power of percussion in a slight balance and spring, any diminution will cause the vibration to fall off considerably; any outward influence, such as thickening of the oil, and imparted motion, will also influence the going of the watch to an undue extent.

There is, in a large and light balance, not that alertness which we find in small and heavy ones, and the wear on the edges of the cylinder is certainly greater, but it has the important advantage of greater steadiness. In a watch having an escape wheel of 15 teeth, making 18,000 vibrations per hour, the extreme edge of the balance should just reach up to the tooth of the wheel, and the weight be so proportioned that, being clear and fully wound up, it should make a little less than two-thirds of a turn. With

This is to certify that the undersigned have formed a limited partnership, pursuant to the provisions of the Revised Statute of the State of New York. That the name or firm under which said partnership is to be conducted is F. S. Maynard & Son. That the general nature of the business intended to be transacted is importing and dealing in foreign and domestic fruits and produce; that the names of the general and special partners interested therein are as follows: Edwin C. Maynard, who resides at Jersey City, N. J., is the general partner, and Isabel Maynard, who resides in the City of Brooklyn, State of New York, is the special partner. That the said Isabel Maynard has contributed the sum of \$5,000 as capital to the common stock and that said co-partnership is to commence on the first day of May, 1893, and is to terminate on the first day of May, 1898. Dated this first day of May, 1893.

E. C. MAYNARD, General partner.

ISABEL MAYNARD, Special partner.

City and county of New York, ss.  
On this first day of November, 1893, before me personally appeared Edwin C. Maynard and Isabel Maynard, to me known and known to me to be the individuals described in and who executed the foregoing instrument and they severally acknowledged to me that they executed the same.  
LEONARD S. WHEELER,  
Notary Public, N. Y. County.

slower vibrations, the size must be increased proportionally.

In a duplex watch the friction is much less; but, as it continues throughout, a change of the momentum of the balance would also considerably affect the long and short vibrations. This escapement affords a facility of altering the proportions of the impulse velocity to the friction in the remainder of the vibration. If the angle formed by the pallets and the notch in the roller is lessened, the drop is increased, and the impulse power so lessened causes not only the vibrations themselves to fall off, but also the smaller ones to be slower than the large.

The following rule will be a guide in conducting experiments. All alterations which increase the arc of vibration without changing the amount of friction, will make the long vibrations slower than the short. If the impulse power remain the same and the friction is increased, the long vibrations will be quicker than the short, inasmuch as to a smaller arc of vibration the same increase of friction bears a greater proportion than to a larger.

If in a duplex watch the balance holes are too large and the balance is brought into such a position as to bring it into a closer proximity with the escape wheel, the long vibrations are sure to be quicker than the small; for two reasons, firstly, on account of increased friction on the rollers; and secondly, in consequence of the greater drop in the escapement. The difference caused by the change in friction on the roller will be considerably influenced by the momentum of the balance. We also find that if the balance holes are large, a considerable difference arises in the rate of going in the four vertical positions.

The pressure of the wheel against the roller is never directed to the center of the latter, but acts obliquely, and if, according to what position the balance is in, it becomes more or less so, it will cause a variation of friction in the pivots in different positions, though it is less in amount than that on the roller, it is extremely inconvenient, as its variable effect can never be compensated for. It is therefore of great importance in a duplex watch that the holes should fit exactly. When the escapement is set out of beat, the point where the vibrations are quickest does not correspond with the center of the arc of escape, and therefore such change will have an influence on isochronism; but of course this ought not to be done, as it would make the escapement imperfect.

In a duplex watch the friction on the roller is sufficient to exercise a proper control over the momentum of the balance, and consequently the latter becomes liberated and gets more free in its action when the motive power relaxes. The balance is, on the other hand, sufficiently independent of the friction to allow the properties of the balance spring to be brought into play. Those circumstances combine to make the general performance of duplex watches very satisfactory. In lever watches and chronometers

the motion of the balance is, except during the arc of escape, unfettered by any escapement friction, and the properties of spring on balance have their full sway.

## Workshop Notes.

**To Recover Gold, Etc.**—In the process of coloring gold trinkets, some of the gold will invariably be dissolved in the coloring bath, which should, therefore, never be thrown away, but different lots are to be poured together, and the gold in these baths recovered. For this do as follows: Dissolve a handful of sulphate of iron in boiling water; add this to your "colors," and it precipitates the small particles of gold. Then draw off the water, being very careful not to disturb the auriferous sediment at the bottom. You will now proceed to wash the sediment from all traces of acid with plenty of boiling water; it will require three or four separate washings, with sufficient time between each to allow the water to cool and the sediment to settle, before pouring off the water. Then dry in an iron vessel by the fire, and fuse in a covered skittle pot with a flux.

**To Separate the Gilding from Base Metals.**—It is necessary for this operation to first granulate or in some other way reduce the metal mixture into a comminuted state. When done, take for each 500 parts 80 parts saltpeter, 40 potash and 20 powdered white glass; first mix the ingredients by themselves, then stir them carefully with the granulated metal, put the whole into a new Hessian crucible, leaving about 30 millimeters (about 1 $\frac{1}{8}$  inches) space on top. Next reverse a somewhat smaller crucible over it and lute it with cement in such a manner that the smaller crucible enters a trifle with its rim lower. Previously perforate the bottom of the upper with a hole about the size of a goose quill. When all this has been done expose it at first to a gentle heat, which increase gradually until the crucible glows with a feeble red glow. Maintain it at this point for about one hour to one and a half hours. You will soon hear how the mass works within and a flame will issue from the upper hole, burning like a candle. As long as this continues the crucible is to be kept at this temperature. When this condition has ceased increase the fire in order to melt the matter in the crucible and retain it for about fifteen minutes in flux; then let the fire cool down until everything is cold. Lift out the crucible, break it, and you will find three layers, one above the other. The upper consists of the flux; the second is metal slag; the third is that of the precious metal, either fine gold or fine silver alone, or if both were contained in the mass then both together. The upper two layers are with a hammer separated as close as possible from the lower, and this is re-melted in another crucible. When in flux (if the mass amounts to 500 parts), add little by little 40 parts saltpeter and 20 parts purified potash, well mixed previously. When well smelted, pour, and the precious metals will be found in a pure condition.



**Q**uality the best!!  
 Assortment the most complete!!

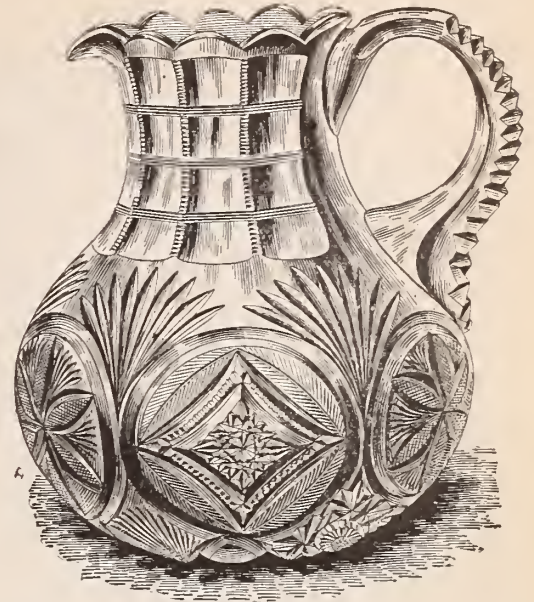

453/58  
 PITCHER. 5 Pts.  
 "Brazilian."

**RICH CUT GLASS**

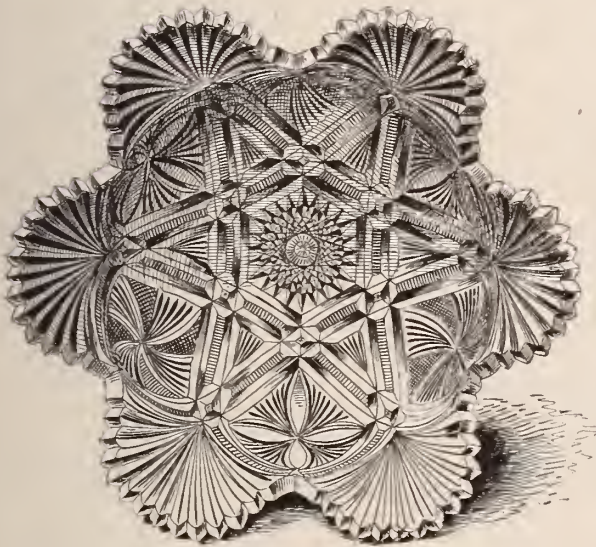

353/56  
 SALAD, 10 inch—"San Salvador."

Designs,  
 THE MOST ORIGINAL.  
 Prices,  
 THE MOST MODERATE.

THE "STRAUS" CUT GLASS RECEIVED A MEDAL AND SIX HIGHEST AWARDS FROM THE JUDGES OF THE WORLD'S FAIR. HIGHEST PREMIUM FOR CUT GLASS EXCLUSIVELY, AGAINST ALL COMPETITORS.



TRADE MARK.

**L. STRAUS & SONS,**



TRADE MARK.

MANUFACTURERS,

42, 44, 46 & 48 WARREN STREET AND 116 CHAMBERS STREET,

# FERDINAND BING & Co.,

106 GRAND ST., N. Y.

—NEW DESIGNS IN—

China Clocks and Gilt Bronze Sets, Fine Painted Dresden Goods in Vases, Cups and Saucers, and Plates; Cararra Marble Statuary, French Cabinets and other Fancy Furniture.

## DÜRRSTEIN & CO., Watch Manufacturers,

DRESDEN AND GLASHÜTTE,  
GERMANY.



**SPECIALTIES:** Repeaters, self-striking minute and quarter repeaters, chronographs, chronometers, finest Glashütte anchor watch (patent union) in sizes for ladies and gents, in plain cases and in cases richly chased, engraved, enameled and diamond set.

PRODUCTS OF FACTORY FOR SALE  
BY LEADING JEWELERS.

REPRESENTED BY

Richard Horstmann,  
BERLIN, S. W.  
ORANIENSTRASSE 101, 102.

## Paper Boxes

At Prices Which Defy  
Competition.

PLAIN AND FANCY JEWELRY  
AND SILVERWARE BOXES  
OUR SPECIALTY.

Our large dealings in Satins, Silks and Sateens in the Corset Business, together with special machinery, enable us to do the BEST OF WORK AT LOW PRICES. Quotations promptly furnished upon receipt of sample.



Address

Warner Bros.,

Bridgeport, Conn.

Box Department.

ALBERT BERGER & CO  
47 MAIDEN LANE, N. Y.  
Spectacles & Optical Goods,  
GROUND LENSES A SPECIALTY.

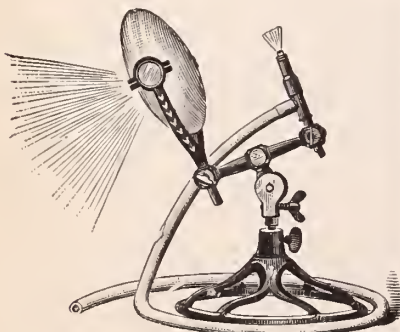

## F. W. GESSWEIN,

39 JOHN STREET,

NEW YORK.

## ENGRAVERS' REFLECTORS

FOR OIL OR GAS, SINGLE OR DOUBLE.

The Glass Reflecting Globe magnifies and concentrates the light, and can be adjusted to cast it on any desired point.

... Circulars and Price Lists on Application ...





## The Rambler's Notes.

WHAT THE RAMBLER SAW AND HEARD AMONG THE DEALERS IN ART POTTERY, CUT GLASS, BRONZES, ETC.



IN addition to the new line of Rudolstadt ware, decorated with hand painted reproductions of celebrated paintings, mentioned in THE CIRCULAR of Jan. 17th, L. Straus

& Sons, 42-48 Warren St., New York, are now showing

in this ware magnificent assortments of vases and other ornaments in the following entirely new finishes: Empire, Nile, Excelsior, Cloisonné and Minerva. These have both plain and relief decorations. The beauty of Rudolstadt ware is now appreciated by dealers in fine pottery, as the soft and delicate colors and graceful outlines create for it a demand surpassed by few, if any, of even the oldest and most popular wares.

IMPORT SAMPLES OF LIMOGES.

\* LAZARUS, ROSENFELD & LEHMAN, 60 Murray St.,

New York, have just opened the import samples of their Limoges ware. The general line shows many new decorations and shapes, which are controlled exclusively by this firm. Large assortments are shown in dinner, tête-à-tête, chocolate, fish, game, ice cream, berry and asparagus sets, as well as in odd dishes, cups and saucers, fruit, salad and berry bowls. These with the pin, pen, desk, toilet and brush and comb trays constitute the novelties which this firm will make a specialty of this year.

\* ARTISTIC FEATURES OF NEAPOLITAN GLASS. NEAPOLITAN GLASS. of the latest artistic line introduced by the Mt. Washington Glass Co. which may be seen at their New York Warerooms, 46 Murray St. The pieces are of white crystal with gold and

colored decorations applied upon the inside by a process patented by this company. The colors show through the glass, producing an effect similar to the underglaze decorations on pottery. The quaint and odd but withal graceful shapes, are in harmony with the decorations upon the piece, whether they be brownies, fish or game designs, or flowers, insects or gold scrollwork. A large variety of pieces come in this ware, among the principal being vases, pitchers and flower holders of many kinds, loving cups, butter plates, bonbonnières, fruit dishes and individual cups and saucers. Like its predecessor, the Colonial, the Neapolitan is very attractive, and if merit warrants popularity its success is already assured.

THE RAMBLER.

## Venetian Art Glass.\*

THE glass interests of Venice are very ancient, and their history is not uninvested with the romance which has always so peculiarly invested the city. The process of making having been brought from the city of Tyre in Phœnicia, the principal site of the glass manufactories of Europe, and of the world, during the dark and Middle Ages, was Venice, whether it was transplanted on the foundation of the city in the seventh century. Antedating and excelling accomplishments in the fictile art both of the Etruscans and the Bohemians during the period of the Renaissance, Venice had the monopoly of the glass manufacture in Europe, an advantage easily sustained because of the superiority of her productions. While Brunelleschi was involving the marvelous dome of the Cathedral of the Madonna della Fiore, in Florence, and Michael Angelo was chiseling himself immortal in marble, and making a deathless name in painting and sculpture, and her own artists rendering glorious her churches and palaces, the glass workers of Venice, out on the little Island of Murano, were no less surely gathering to themselves imperishable fame in creations which have found place beside the metal work of Benvenuto Cellini, in all of the museums and in many of the grandest palaces in Europe. The pity is, that the names of many of those worthy

\* Adapted from the *Decorator and Furnisher*.

workmen are preserved only in their remote descendants; that we do not find them engraved upon the pieces now shown as evidences, no less of the art-principle which prompted the design than of the mechanical skill which gave it expression.

But Venice was destined not uninteruptedly to profit by the monopoly that she had so deservedly acquired in the manufacture of glass. Colbert, the enterprising Prime Minister of Louis XIV., together with lace making and tapestry weaving, during the latter half of the 17th century, introduced the manufacture of glass into France. There is no evidence, however, that the glass manufactures of France ever attained the degree of perfection of those of Venice, or, at any rate they were pursued upon different lines, as in the case of the Bohemian, Hungarian, Russian and other glass manufactures of the present day—the blown glass of Murano, showing in the pieces made, a uniqueness of conception and a delicacy of execution unequalled by all attempts in the fictile art, whether ancient or modern.

Yet dark days were to come to Venice, in its glass, as in other industries which engaged the commercial energies of the people. With the changes which crept into the government and social life, the decline of the power of the Doges, and the loss of the patronage which comes of official and social influence and wealth, the interest in the glass manufactures of Murano flagged—the workmen, doubtless, becoming disheartened, and for lack of impetus, perhaps, allowing the art instinct, which found expression in their beautiful vases, tazzas, ewers and other articles in blown glass, to become dormant, although not, indeed, to die out. It is said that even before the end of the 17th century, "the artistic preception of form and color" which had formerly characterized the Murano workmen, had, to a great extent, left their minds; and it was distressing to compare the heavy, ill-shaped, highly colored pieces then made, with the exquisitely colored and gracefully designed creations of *virtu* of the past. It is needless to add that the invasion of Napoleon I., with his greed for collecting treasures, in the theory that, "To the victor belongs the spoils," did little to better the condition of Venice, as involving her industries; while



## The Connoisseur.

(Continued from page 39.)

but for the impluse which slumbered, but was not dead, the Austrian power might have extinguished forever all effort in the direction of art.

As it was, though in a sense paralyzed, it was not wholly destroyed, as facts have shown, an incentive being needed to prove that it was only slumbering, to be aroused when the time came for it to exert itself. The traditions of the old glass blowers of Murano had been proudly preserved, and awaited only encouraging opportunity to again kindle the fires in the Murano furnaces, for transmuting the sand, washed down to the shores of the island from the Alps, into things of beauty.

At length the opportunity came. Strange to relate, however, the revival of the blown-glass manufacturers of Murano is not due to any one of the descendants of the old workers, but to Dr. Salviati, a lawyer of eminence, who, we are told, "while exercising his professional duties at the Venetian forum, spent his leisure hours in admiring and studying the sublime works left by his ancient compatriots." It grieved him immeasurably to contemplate the lethargy that enshrouded the glass industries of Venice. At first he was most actively exercised in regard to the decadence of the mosaic art, and laying aside his briefs and relegating jurisprudence to fellows more

directly in sympathy with the legal profession, he conceived the idea of resuscitating Venetian mosaics; and by inevitable consequence, he was led also to meditate the resuscitation of Venetian art-glass. This was in the year 1859. Associating with him Lorenzo Radi, an artisan who, for many years, had occupied himself in the study of vitrefaction, Dr. Salviati devoted not only his time to the study of the manufacture of the gold, silver and colored enamels used in the old Venetian mosaics, but his wealth to their practical development and perfection.

The success which has attended Dr. Salviati's efforts has more than compensated him for the years of study, labor and money devoted to the development of his beloved art.

From the time of successful re-establishment until the present, the furnaces of Murano have been in blast, and the production of blown-glass has been uninterrupted save, it may here be remarked, during the vacation period of a month or six weeks in the latter part of the summer, when the weather becomes too oppressively warm to continue the work. The art instinct that, in ancient times, lifted the blown-glass of Murano from the level of mere manufacture, is visible in the creations of the present. It may be ever so simple an article, a tiny jug, for instance, a wine glass, or a little funnel-shaped vase opening like a wild morning glory and mounted upon the tails of a couple of

dolphins, it is inexpressibly delicate in effect, with every line of grace imprisoned in its shape, and of matchless coloring, whatever may be the hue, tone or tint. The blown glass of Venice really defies criticism. Infinite variety, indeed, appears in conception, design, tint and finish, and one passes from piece to piece at a loss to decide with which to be the most delighted.

The chandelier in *avventurina*, like translucent gold, or like an immense creation of frost work set with delicately tinted roses, hung about with crystal chains, is ravishing; while the scallop-shell card-receiver, with a winged horse for a handle is charming. The poetry in a mirror rarely attains full significance, unless it be one of those incomparable beveled plates of Venice with floriated crystal frame of Venetian workmanship. Wax candles seem never to burn with a light quite so softly delightful as in Venetian glass candelabra; while the enjoyment of feasting is inevitably enhanced by the service of Venetian glass for the fruits and the wines. My lady's boudoir is scarcely complete in its ornamentation without the delicate Venetian glass vase to support the bunch of roses or orchids, which may daily come from some admirer or generous friend; nor is any cabinet thoroughly furnished which does not show one or more specimens of this exquisite manufacture of the humble little island and town so jealously watched over by "The Queen of the Adriatic."



## No Stock Complete without Elgin Cases.

Elgin Pride, 16 karat Filled. *GUARANTEED 25 YEARS.*

Elgin Commander, 14 karat, Filled. *GUARANTEED 20 YEARS.*

Elgin Giant, 10 karat, Filled. *GUARANTEED 20 YEARS.*

**O, 6, 16 AND 18 SIZE.**

ELGIN TIGER, 14 KARAT ROLLED PLATE. Send your business address and we will mail you Catalogue. Electrotypes sent upon application.

ALL CASES MANUFACTURED BY US ARE STAMPED WITH OUR REGISTERED TRADE MARKS.

## ILLINOIS WATCH CASE CO.

FACTORY, ELGIN, ILL.

ESTABLISHED 1870.

### J. L. CLARK,

**SWEEP SMELTER AND REFINER OF GOLD AND SILVER.**

Buys every kind of Gold and Silverware, Jewelry, Watches and Platinum. Full market value paid.

**No. 724 Filbert Street, Philadelphia, Pa.**

SEND BY EXPRESS or Registered Mail. If my price is not satisfactory, I will return all articles.

A. A. MARGOT.

E. F. MARGOT.

### MARGOT BROTHERS,

Watch Case Manufacturers, Engine Turners and Jobbers,

11 FRANKLIN ST. (FORMERLY 23 WATER ST.) BOSTON, MASS.

Special Attention to Watch Case Repairing, Springing, Re-engine Turning, Engraving, Polishing etc. Flat Glasses Fitted, Jewelry Silverware, Dies, etc., engine turned.

Particular Attention to Orders from Expresses.



**AMERICAN RAILWAY SUPPLY CO.**  
24 Park Place, NEW YORK.





ART GOODS AND SPECIALTIES ♦——

FOR JEWELERS and ART DEALERS.

WE ARE EXHIBITING THE HIGHEST GRADE OF ART GOODS IN FINE POTTERY, CLOCKS, BRONZES, MARBLE, ONYX, VENETIAN, FRENCH AND DRESDEN FURNITURE, GLASSWARE, CLOISONNE, FAIENCE, BISQUE, ETC., ETC., AND BEAUTIFUL COLLECTIONS OF THE MOST CELEBRATED MAKES IN FINE PORCELAINS.

WE HOPE EVERY BUYER WILL RECOGNIZE THE IMPORTANCE OF SEEING THESE REPRESENTATIVE LINES BEFORE PLACING ORDERS, AND MAKE US AN EARLY VISIT.

**GEO. BORGFELDT & CO.,**

18, 20, 22 WASHINGTON PLACE, Cor. Greene St.,

**NEW YORK.**



**The Other Side of Life.**

CLARISSA.—I owe you an apology, dearest.  
 FRED.—Don't speak of it. I wish to remain a preferred creditor.—*Puck.*

NATURE'S ALARM-CLOCK.

STRAWBER.—What have you in that envelope that you are handling so carefully?  
 SINGERLY.—A live fly. I've got to catch an early train in the morning.—*Judge.*

THE ONLY RESULT.

"Why don't you give your servant an alarm clock so that she will get up early in the morning?"  
 "We've tried it." was the sad reply.  
 "What was the result?"  
 "It simply disturbed her rest a little and made her snore worse than ever."—*Washington Star.*

NOT NATURAL.

"That clock," said the man who was looking through the Senate chamber, "don't call out the hour no way, does it?"  
 "No," replied the guide.  
 "Whose property is it?"  
 "Why, it belongs to the Union."  
 "To which?"  
 "To the Union."  
 "An' don't strike? No, siree. Ye can't fool me."—*Washington Star.*

BOARDER—Is this genuine vegetable soup?  
 WAITER—Yes, sir; 14 carrots fine.—*Rochester Democrat.*

ORANGE—I see Knowitall has taken to wearing glasses.  
 MOCK ORANGE—That is not strange. He is afflicted with a disease of the I.—*New York Tribune.*

EXCESSIVE PLAINNESS.

MISS DE COPPS—Miss Bunting is very plain. I hear.  
 MISS HARDHEART—Well, she's so homely that her diamonds won't sparkle when she wears them.—*Judge.*

**Cold Comfort.**

It was in the old days when, in a certain country region, there was much thrift and very little vain display. Old Farmer True, however, always had longings for the luxuries of life, such longings, indeed, that the preacher once rebuked him from the pulpit for wearing a waistcoat too gorgeously brocaded. One Fall Farmer True, unable to resist his longing for the beautiful, sold a large part of his hay in order to buy some new green blinds for his house, and a smart kitchen clock. The neighbors, most of whom lived in a blindless condition, and were satisfied

with the clocks of their ancestors, heartily disapproved, but their scorn had no power to damp the ardor of Farmer True, joyous in the possession of his treasures.



SHE KNEW TOO MUCH.

MADAME—What do you mean by putting my jewelry in this water?  
 SERVANT—It won't hurt'em mum; I heered they've been in soak menny a toime. *Judge.*

Spring came, and with it the downfall of his pride, for alas! he had not hay enough to feed his cattle until they should be turned out to grass. Thereupon he humbly sought a neighbor, and asked him if he had any hay to lend.  
 "Well," said the neighbor, deliberately, stroking his chin, "I dunno I've got any hay to lend, an' I dunno's I've got any to sell. Why don't ye drive yer cattle up an' let 'em look at yer green blinds an' hear yer clock strike?"—*The Youth's Companion.*

**CHRYSO-CERAMICS,**  
**GOLD COVERED PORCELAIN.**  
**M. & E. HEALEY,**  
 1122 CONNECTICUT AVE., WASHINGTON, D. C.  
 MEDAL AT WORLD'S COLUMBIAN EXPOSITION.

**"Old English"**  
 Coffee Spoon.



Towle Mfg. Co.,  
 MANUFACTURERS OF  
**STERLING SILVERWARE.**  
 NEWBURYPORT: No. 214 Merrimack St. CHICAGO: Nos. 149 & 151 State St.

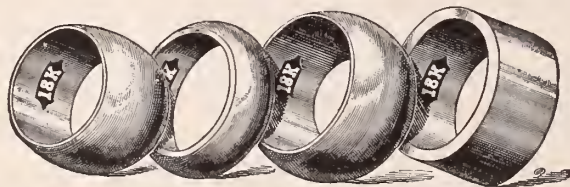

Band Rings metal lapped. Full value allowed for old gold.

**PLAIN SOLID GOLD RINGS.**  
**HILDRETH MFG. CO.,**

53 MAIDEN LANE, NEW YORK.

**A. J. LOGAN,**  
 MANUFACTURER OF  
 WATCH TOOLS, HAIR SPRINGS AND  
**WATCH MATERIALS.**  
 ◁ New Catalogue just issued, Sent on Application. ▷  
 WALTHAM, MASS.

PATENT paneled METAL  
**CEILING**  
 Stamped Raised Panels.  
 ARTISTIC AND PERMANENT.



Easily applied in new buildings, and over old broken plaster or wood Ceilings. If interested in building or repairing, send stamp for Illustrated Catalogue, and state if CHURCH, HALL, STORE, OFFICE, or SCHOOL Ceiling is wanted. Address

A. NORTHROP & CO., Pittsburg, Pa.





No. 1718

# HINRICHS & CO.,

29 AND 31 PARK PLACE, NEW YORK.

## Complete Lines of Import Samples

ESPECIALLY SELECTED FOR THE JEWELRY TRADE.

### BRIC-A-BRAC and ART POTTERY.

Doulton, Worcester, Royal Vienna, Teplitz, Dresden, Sevres, Coalport, Austrian Faience, Bisque Figures and Candelabras.

BOHEMIAN AND FRENCH CHRYSANTHEMUM VASES and Bouquet Holders, Atomizers, Cologne Bottles and Jewel Boxes.



No. 1347.



#### SPECIALTIES IN LIMOGES CHINA.

A. D. Cups and Saucers, Chocolate Cups, Teas and Coffees, Mustache Cups, designs and decorations entirely new and exclusively our own.

OUR SPRING STOCK was never more complete than now, and we never had a finer line of goods. These we will sell at greatly reduced prices for the next three months.

When you come to the city, don't fail to give us a call. Catalogues and Price Lists on application.



No. 1326/15.

**WOOD & HUGHES,**  
STERLING SILVERWARE MANUFACTURERS  
New York Agents for the Derby Silver Co.'s  
FINE QUADRUPLE PLATED WARE,  
NO. 16 JOHN STREET, - NEW YORK  
206 Kearney St., San Francisco, Cal.  
HASKELL & MUEGGE, Agents.

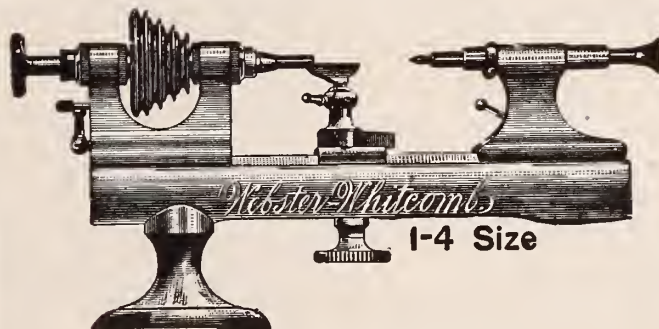

STRONGEST GUARANTEES.

Quality  
Maintained.  
Prices to  
Suit the Times.

Ask for our New  
Prices and  
Terms for 1894.

## American Watch Tool Company,

Chymistry Dist., Waltham, Mass., Stoney Batter Works.

**"TIME IS MONEY"**  
SEND YOUR PRESCRIPTIONS  
AND REPAIR WORK WHERE  
IT IS DONE ACCURATELY WITH-  
OUT DELAY.  
**F. KIRSTEIN'S SONS CO.**  
SEND FOR CATALOGUE. ROCHESTER, N.Y.

### CROUCH & FITZGERALD.

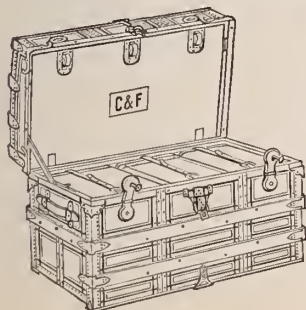

Jewelry Trunks  
and Cases,  
161  
Broadway,  
Bet Cortlandt and  
Lil'erty Sts.,  
688 B'way,  
01 6th Ave.,  
NEW YORK.

If Your Sales  
Are Not Satisfactory

ADDRESS  
**DE B. O. SCOTT,**  
20 Murray Street, New York.

AUCTIONEER.

Specialties: Watches, Clocks, Bric-a-Brac, &c.

Write for particulars and references

AWARD AT WORLD'S FAIR, CHICAGO, 1893

The Providence Shell Works.  
**W. K. POTTER,**  
346 Westminster St., Providence, R. I.



Tortoise Shell Goods, Combs, Hair Orna-  
ments, Jewelry, Etc.  
Shell Work made to order on contract. Repairing for  
the trade in all its branches.





# B. & W. B. SMITH,

220 W. 29<sup>TH</sup> ST.,  
NEW YORK.

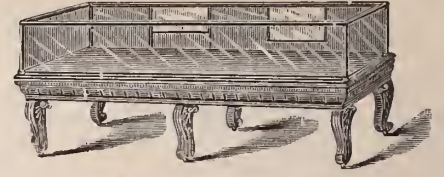
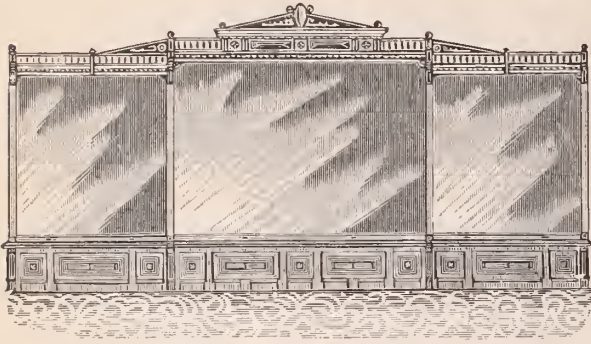

Dust Tight Wall Cases. Improved system of Shelving and Electric Wall and Counter Cases Lighting.

IMPROVED DUST TIGHT.

◁ SMALL CASES FOR SPECIALTIES. ▷

ALL GLASS.

NO MOULDINGS

## The "Bryant" Rings.

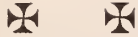

Are widely advertised and will sell when anything will, therefore every Retail Jeweler should buy them.

IF NOT CALLED UPON BY OUR TRAVELERS  
ORDER DIRECT FROM

M. B. BRYANT & CO., - 10 MAIDEN LANE, N. Y.

OLDEST RING MAKERS IN AMERICA.



### Jules Jürgensen OF COPENHAGEN.

The reputation these watches have maintained for Fifty Years has never been equalled, being made on strictly scientific principles and no expense spared to give the Best results in mechanism and timekeeping qualities.

SOLE AGENTS,  
John C. Hyde's Sons,  
NO. 22 MAIDEN LANE.

### CAMPBELL-METCALF SILVER CO.



176 Broadway, N. Y., Room 14. 66 Stewart St., Prov., R. I. Mills Bldg., San Francisco, 8th Floor, Room 1.

### J. PRINCE, Jewelry Auctioneer,

At liberty from January 1st, 1894. Retail Jewelers only. Address,

Rooms 9 & 10, 137 BROADWAY  
N. Y. CITY.

### S. F. MYERS & CO.,

WHOLESALE JEWELERS,  
MYERS BUILDINGS, - - NEW YORK.

1894 ISSUE, No. 38,

### OUR ROYAL CATALOGUE

Illustrates all that is new, unique and desirable in everything that pertains to jewelry.

Sent free to dealers who have not received it.

TWENTY-TWO DEPARTMENTS.  
SEVEN DOUBLE FLOORS.

Myers Buildings, 48-50 Maiden Lane, New York,  
33-35 Liberty St.,

### S. P. HOWARD, Gold and Silver Assayer.

Refiner and Sweep Smelter,  
33 MAIDEN LANE, NEW YORK.  
Smelting and Refining Works,  
28 & 30 Cumberland Street, Brooklyn, N. Y.  
Specialties: Sweepings, Gold, Silver and Platinum

### J. SCHAWEL & CO., 29 John St., N. Y.

GOLD & SILVER REFINERS, ASSAYERS & SWEEP SMELTERS.  
STERLING SILVER, 925/1000 FINE IN SHEET AND WIRE.  
Soft Platinum, Sheet and Wire for Manufacturing Jewelers.

### WM. SMITH & CO.,

Manufacturers of Gold, Silver and Roll Plate Chains and Jewelry.



Novelties in Gold and Silver Bead Necklaces and Bracelets. Also a large line of Chain Trimmings and Silver Rings.

Office: 5 and 7 Maiden Lane, New York.      Factory: 61 Peck Street, Providence, R. I.

FRENCH      ENGLISH  
CLOCKS AND      HALL CLOCKS AND  
MATERIALS.      MATERIALS

CHAS. JACQUES CLOCK CO.,      22 CORTLANDT ST., N. Y.

IT PAYS TO KEEP IN TOUCH WITH TRADE AFFAIRS.  
THE JEWELERS CIRCULAR, For 4c. a Week will do it. **Subscribe.**

1869-1894=Twenty-five Years, Oldest, Best, Brightest, Newest, =The Jewelers' Circular.



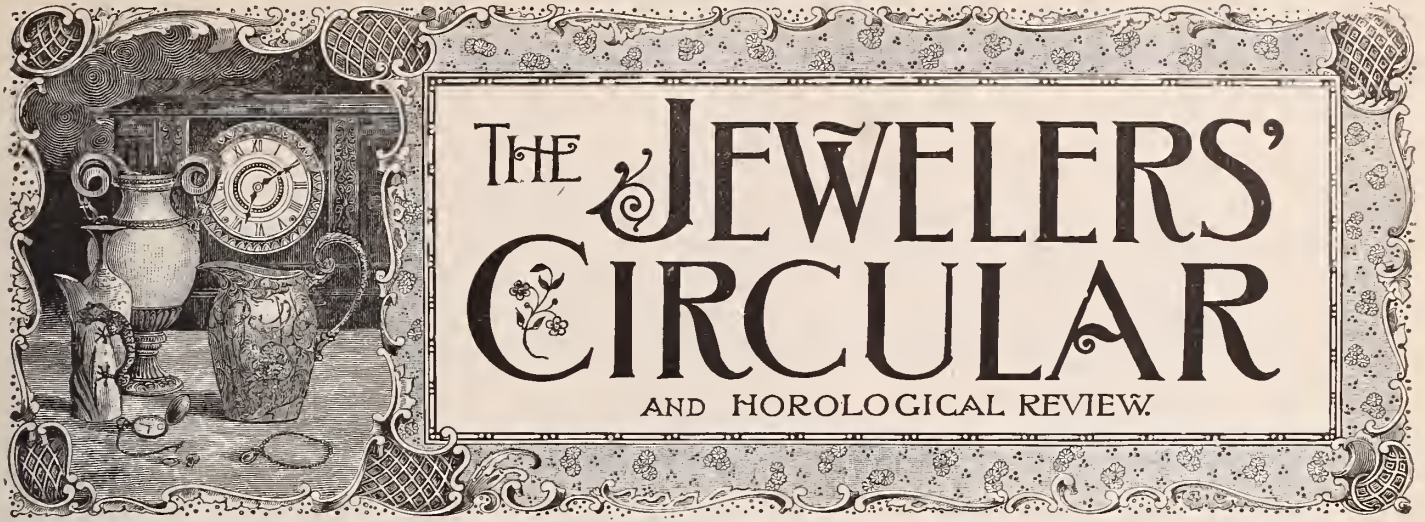

Copyright by THE JEWELERS' CIRCULAR PUB. CO.

189 Broadway, New York.

Entered at the Post Office in N. Y. as second-class matter.

VOL. XXVIII.

NEW YORK, WEDNESDAY, FEBRUARY 21, 1894.

NO. 3.

ANCIENT STATUES IN THE PRECIOUS METALS.\*

PART II.

THE most remarkable works in gold and silver made during the mediæval period were chiefly of a religious character. The statuette - reliquary of Saint Foy, illustrated in this article, which belongs to the valuable collection of the Conques monastery, in the south of France, is a very striking specimen of the art, at once bold and naïve, of the tenth century. This statuette, 85 centimeters high, is of repoussé gold. The saint is seated in an elegant

gree work. Her head is covered with an imperial crown tastefully adorned with precious stones and enameled motifs. She

finied; still the general effect is impressive. The large eyes, in white enamel, with dark blue glass for the apples, give a strange life to the statuette.

The other engraving reproduces one of the most perfect works of the 14th century. It is a statuette 55 centimeters high of the Holy Virgin, in gilt silver, standing on a pedestal in the shape of a casket. This pedestal is adorned with 14 plaques exhibit-



GILT SILVER STATUE OF ST. NICHOLAS.



GILT SILVER STATUE OF THE HOLY VIRGIN.



STATUETTE-RELIQUARY OF ST. FOY.

arm chair of gilt silver; she wears a robe richly adorned with jewels most of which are cabochons, and winding courses of fili-

has elaborate pendant earrings, consisting of very fine filigree arabesques and garnets. The whole costume is somewhat in the Byzantine style. The proportions of the body are not perfect and the features are not re-

ing scenes in the New Testament. The figures, engraved, are in relief on a translucent enamel ground of different colors, studded with six petaled fleurettes. The Virgin carries on her left arm the infant

\* Continued from page 4, Feb. 14.



# DEITSCH BROS.,

7 EAST 17TH ST., NEW YORK.

## LEATHER GOODS.

EBONY AND SILVER COMBINATIONS.

ORIGINATORS AND MAKERS OF

NOVELTIES IN LEATHER AND STERLING SILVER COMBINATIONS.



\*\*\*\*\*

### CROSS & BEGUELIN,

17 MAIDEN LANE, NEW YORK,

ALL GRADES OF SWISS AND AMERICAN WATCHES, DIAMONDS, GOLD AND ROLLED PLATE JEWELRY, OPERA AND FIELD GLASSES, TOOLS AND MATERIAL.

SOLE AGENTS FOR THE **Rockford Watch Co. MATERIAL.** MANUFACTURERS OF THE **Centennial Watches.**

SEND FOR OUR WATCH MATERIAL AND TOOL PRICE LIST FOR 1894.

\*\*\*\*\*

### AMERICAN SYNDICATE OF Jewelers' Auctioneers.

ESTABLISHED for the sole purpose of conducting sales for established Jewelers in the United States, Canada and Mexico. We do not sacrifice your goods. We take no sales on a percentage. Our terms are strictly one-half the profits realized on all goods sold. We guarantee you against any loss. We pay all our own expenses; we don't ask you to pay one cent of expense on our account. We buy stocks complete as well as sell them. If your stock is small, or your assortment is not complete, we will furnish from one to ten thousand dollars worth of any kind of stock you may need and in which you need not invest one penny. Don't make any arrangements with others until you read our pamphlet which we will send you free, giving you full particulars of our style of doing business, and the liberal offers we make to jewelers. We don't care how small your stock is, we will furnish all the stock you need to make a successful sale. We challenge the world for any fairer or more liberal propositions than we make jewelers. Don't fail to send us your address, and we will send you our business pamphlet, which gives you full explanations as to our terms and style of doing business. Address,

### AMERICAN SYNDICATE OF JEWELERS' AUCTIONEERS.

Offices: 20 WEST 14th STREET, NEW YORK. 611 PENN AVE., WASHINGTON. D. C.

### "THE BEST BUTTON MADE."

THE KREMENTZ

IN GOLD IN ROLLED PLATE

FROM FROM

KREMENTZ & CO. ONE PIECE FROM

AND ALL JOBBERS. ALL JOBBERS

**COLLAR BUTTON.**

IS THE ORIGINAL ONE PIECE BUTTON. IS STILL THE BEST AND STILL UNSURPASSED.

Sold by all wholesale dealers at manufacturer's price.

**A. N. CLARK,** PLAINVILLE, CONN.

Manufacturer of the Celebrated **LOOP WATCH KEY.**

The Best for the Price in the World. CROSBY'S JEWELING TOOLS IMPROVED.

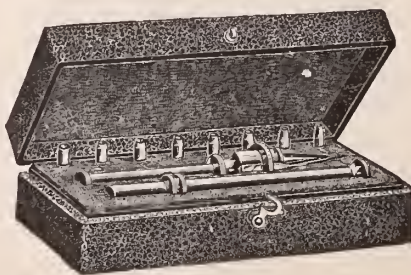

Will quote royalty or price for the manufacturing of articles of real worth.

ESTABLISHED 1837.

### GEO. O. STREET & SONS.

MAKERS OF

Fine Rings, Lockets, Seals, Sleeve Buttons and Links,

15 John Street, NEW YORK.

JACOT & SON IMPORTERS AND MANUFACTURERS OF

**MUSICAL BOXES**

298 BROADWAY. NEW YORK



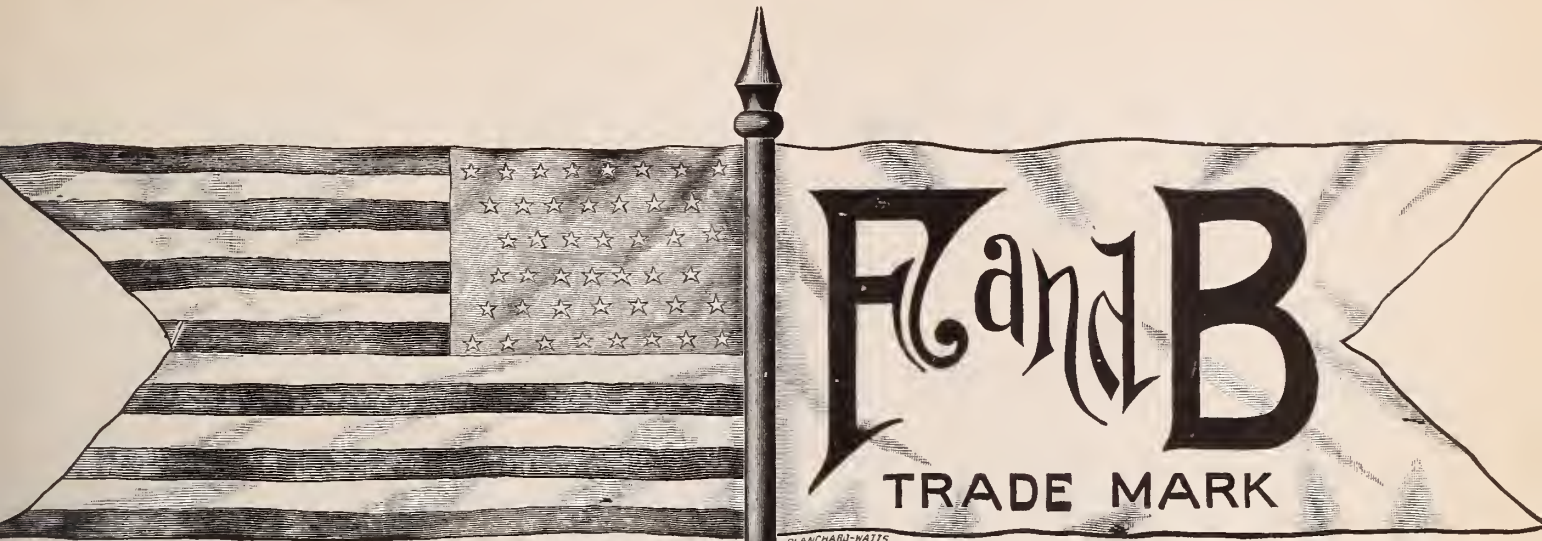

Our American F. & B.  $\frac{1}{10}$  Gold Chains will assay 10 K. 1-10 gold, and are guaranteed for ten years.

Our regular line of Chains is made of heavy gold plate, finely finished, and guaranteed for five years.



**Chains**  
Our new line of chains will assay 10 karat 1-10 gold. All gold soldered.  
**American F. & B. 1-10 gold.**

WE RECEIVED  
**4 MEDALS**  
AT THE WORLD'S FAIR.

Mount Hope Button.

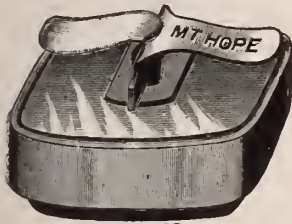

CLOSED.

<p><b>Watch Chains for Gentlemen</b></p> <p>These goods are of fine quality, and guaranteed to give satisfaction. Some recently added have sold far beyond expectation. They are made of heavy rolled plate in all sizes and patterns.</p>	<p><b>Watch Chains for Ladies</b></p> <p>Our Victoria and Princess chains are neat and pretty. They are made in all bright, Roman and bright, platinum and bright gold, and have one or two charms.</p>
--	---

Mount Hope Button

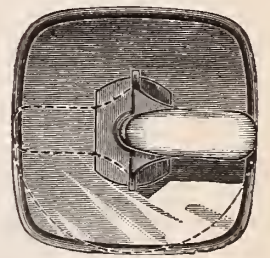

OPEN.

<p><b>Charms</b></p> <p>This line is adapted to ladies' or gentlemen's chains, and includes a number of heart charms in Roman, bright and satin finish, with stones and without.</p>	<p><b>Hair Chain Mountings</b></p> <p>In solid gold and rolled plate. We are headquarters and make everything desirable in this line.</p>	<p><b>Bracelets</b></p> <p>We make a large stock of curb bracelets in five sizes, besides the graduated links, with padlocks and snaps, in chased and plain polished, Roman, rolled silver plate and sterling silver. Also padlocks with keys and a push snap.</p>
--	---	--

<p><b>Pins</b></p> <p>Our large line of lace and cuff pins comprise many desirable patterns in gold fronts engraved and trimmed. Also includes baby pins and scarf pins.</p>	<p><b>"Mt. Hope" Buttons</b></p> <p>These are superior to any button in the world. They are easy to put in and easy to take out of the cuff.</p>	<p><b>Link Buttons</b></p> <p>This line has increased rapidly with us, and is very low in price, embracing all styles in Roman, chased, engraved and plain, with and without stones, and some in enamel.</p>	<p><b>Crosses</b></p> <p>We make four sizes of gold filled in plain, engraved and set with stones, and suitable for our neck chains.</p>
--	--	--	--

<p><b>Sterling Silver and Solid Gold Sword Scarf Pins</b></p>	<p><b>Glove Buttoners</b></p> <p>We make the Interlocking and one with a twist handle in gold rolled plate and silver rolled plate.</p>	<p><b>Earrings</b></p> <p>This line includes many pretty patterns in gold fronts engraved, some with pretty trimmings and a small line of loop drops.</p>	<p><b>Neck Chains</b></p> <p>We make a variety of neck-chains in bright and Roman, with snaps.</p>	<p><b>Sterling Silver Bracelets and Padlocks</b></p>
---	---	---	--	--

<p><b>Gold Locket Set with Diamonds</b></p> <p>These lockets are made of 10 karat gold throughout and set with brilliant diamonds. They cannot be surpassed in finish or cheapness of price.</p>	<p><b>Gold Locket Engraved</b></p> <p>These lockets are also made of 10 karat gold throughout, with beautiful designs engraved thereon and the price is so low that they cannot fail to be in great demand.</p>	<p><b>Gold Front Locket</b></p> <p>This line is very extensive. Many patterns are plain polished, others nicely engraved, with and without stones.</p>	<p><b>Rollled-Plate Locket</b></p> <p>This line is almost endless, and consists of nearly every conceivable shape, size and style. Some are set with imitation diamonds, rubies and sapphires.</p>
--	---	--	--

We have put upon the market a line of Gentlemen's Chains and Ladies' Chain Bracelets made of 1-10 gold stock. Every joint is soldered with gold, and every Chain or Bracelet will assay more than 1-10 gold. They are our AMERICAN F. & B. 1-10 GOLD goods, and are so stamped. Bar, Chain and Swivel are stamped 1-10 gold.

**FOSTER & BAILEY, Providence, R. I.**



Jesus, and holds with her right hand a fleur-de-lis which is a reliquary of gold and rock crystal. Pearls and sapphires are set at the top and on the stem of the fleur-de-lis. Along the top border of the pedestal runs an inscription in Gothic letters, filled with blue enamel, informing us that the statuette was given to the Abbaye de Saint Denis by the Queen Jeanne d'Evreux, widow of Charles IV. of France, the 28th of April, 1339. This work now belongs to the Louvre.

A very curious statuette of gilt silver, of the 15th century is that of Saint Nicholas, belonging to Saint Jacques church, Amiens. The work, which is in repoussé, is wonderfully executed. The fervent expression of the face is very striking, with the eyes half shut and the mouth muttering words of blessing. The folds of the costume are most exactly rendered as are all the details of the work. Standing in a tub, near the good Bishop of Myrre, are the three little children mentioned in the well-known old song.

#### 2,000 Persons to Manufacture Optical Devices.

GRAND RAPIDS, Mich., Feb. 15.—Arthur Linton, said to be representing an English syndicate of optical goods manufacturers, has been in the city looking over the ground for the establishment of an American factory for the syndicate. Mr. Linton says only the highest grades of optical

goods, microscopes, telescopes, lenses and frames will be made, and that some 2,000 hands will be employed in the works, making this point the center of their American trade. He was favorably impressed with the water power and manufacturing facilities of this city.

It is understood that Detroit and Saginaw are also bidding for the same enterprise.

#### Thieves Out of the Way for Two Years.

NEW ORLEANS, La., Feb. 14.—Two well-known criminals were convicted last week. They were B. Lafargue, alias Diamond, and Joseph Baptiste, alias Chinee. On the fifth of July last they entered the store of the New York Jewelry Co., at the corner of Canal and Royal Sts., and stole an amount of goods that was approximated at \$175. The robbery was skilfully done and excited a great deal of interest at the time.

The men were given a hearing last week; the jury returned a verdict of petit larceny and sent both of the men to the Penitentiary to serve two years.

#### Firebugs Supposed to be Responsible in This Case.

OMAHA, Neb., Feb. 14.—About 5 o'clock last Tuesday morning fire broke out in the jewelry store of C. A. Houghtaling, a one-story frame building on Main St., at Nelson. The fire progressed so rapidly that in a few seconds the whole building was in flames.

The stock of jewelry was valued at \$1,700; partially insured. The building was valued at \$1,000, with no insurance.

The fire is supposed to have been of incendiary origin.

#### The Settlement of the Estate of George C. Shreve.

SAN FRANCISCO, Cal., Feb. 12.—The following is the basis of settlement in the probate court of the estate of the late George C. Shreve:

Probate Judge Coffey has granted the petition of W. W. Montague and H. L. Dodge, executors of the will of the late George C. Shreve, authorizing them to transfer to the newly incorporated Shreve & Co., all interest of the estate in the business and property of George C. Shreve & Co., upon payment to the executors of the sum of \$79,594.70 including \$3,000 before advanced to the executors, and upon delivery to Rebecca R. Shreve of 1,000 shares of stock in the Shreve & Co., 500 in her name and 500 in that of George Shreve; also to execute a release to George Bonny and Albert J. Lewis, surviving partners of the deceased, of all claims and demands against the estate.

#### Death of Walter H. Eaton.

LAWRENCE, Mass., Feb. 15.—Walter H. Eaton, for many years a resident of Andover, died quite suddenly last Wednesday afternoon. He had been in poor health for

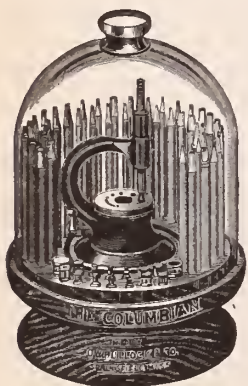

#### OUR OWN ★ "COLUMBIAN"

Fifty Punch Staking Tool, LEADS ALL OTHERS in STYLE, FINISH and ACCURACY. Hundreds of practical Watch Makers pronounce it the BEST.

Nickel frame, mahogany base, extra fine tempered steel punches and stumps.

—→ FULLY WARRANTED. ←—

For full description send five cents in stamps, with business card, for New Catalogue of OVER ONE THOUSAND varieties of fine Watch and Bench Tools of OUR OWN MAKE, many entirely new.

**O. W. BULLOCK & CO.,**  
SPRINGFIELD, MASS.

**VICTOR.** ⓧ ⓧ  
SIMPLEST FEED. ALWAYS THE SAME.  
GUARANTEED FOR ONE YEAR.

**THE VICTOR**  
**FOUNTAIN PEN**  
(Pat. Feb. 4, 1890.)

**THE BOSTON PEN CO.,**  
N. C. Whitaker & Co., Proprietors.  
363 Washington Street, Boston, Mass.,  
Manufacturers of finest quality  
TORTOISE : SHELL : AND : HORN : GOODS  
In every variety. Also Aluminum Hair Pins.  
Send for illustrated Pen Price List No. 1.

**NEW ! IMPROVED NEW !**  
Adjustable "Eclipse" Eye Glasses.

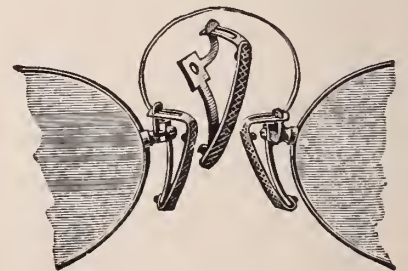

PATENT APPLIED FOR.

We claim this invention to be the only one which combines the advantages of both the adjustable and offset guards. We will furnish these frames or guards in either Zylonite or Cork.

WRITE FOR CIRCULAR,  
**JOHN SCHEIDIG & CO.,** SOLE AGENTS  
43 MAIDEN LANE, NEW YORK.



*"Pairpoint"*  
MAKERS OF

Hollow and  
"1880" Flat Ware.



No. 6300. ORANGE HOLDER,

# MFG. COMPANY,

Gold and Silver Plate.

FACTORIES:

New Bedford,  
Mass.

HEADQUARTERS FOR

RICH CUT GLASS.

COLONIAL,  
ROYAL FLEMISH,  
CROWN MILANO.

Decorated Art Glass.



No. 2697. EMBOSSED CANDLESTICK

SALESROOMS:

NEW YORK, - - - 20 Maiden Lane.  
CHICAGO, - - - 224 Wabash Avenue.  
SAN FRANCISCO, 220 Sutter Street.



No. 6301. ORANGE HOLDER.

**A. J. LOGAN,**  
MANUFACTURER OF  
WATCH TOOLS, HAIR SPRINGS AND  
WATCH MATERIALS.

< New Catalogue just issued, Sent on Application. >  
WALTHAM, MASS.

We sell to the legitimate Jewelry and Stationery  
trade only.



CHOICE PAPERS

MAKERS OF

FINE STATIONERY

For Correspondence, Wedding and Business Use, handsomely  
boxed, specially suited to the Jewelry Trade.

18 MURRAY STREET, NEW YORK.



SPECIALTY: SALES OF  
JEWELRY, BRIC-À-BRAC  
AND  
ARTICLES OF VERTU



# R. WALLACE & SONS MFG. CO.

**SILVERSMITHS**

Trade Mark.



R. W. & S.  
Sterling.

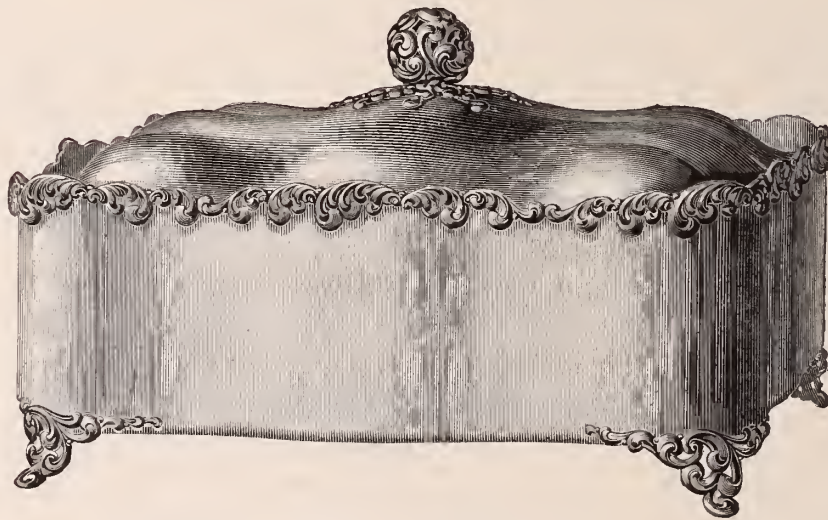

WAVERLEY SARDINE BOX.

Manufactories and  
Main Office,

WALLINGFORD, - - CONN.

BRANCHES :

NEW YORK  
3 PARK PLACE.

SAN FRANCISCO,  
120 SUTTER STREET.

CHICAGO  
86 WABASH AVENUE.



several years, though his last illness was of only a few days' duration. Fifteen years ago he purchased the jewelry business of Geo. Herrick, which he carried on in a part of the store now owned by Arthur Bliss. After that he moved to Methuen, where for three years he conducted his business, giving it up finally to become Mr. Bliss' assistant in the drug business, he being a registered pharmacist. He leaves a widow and step-mother.

Mr. Eaton belonged to the Masons and Odd Fellows in Lawrence and to the Royal Arcanum, Andover and the Home Circle in Methuen.

**Herman Gerwich Commits Suicide While Despondent.**

HARTFORD, Conn., Feb. 15.—Herman Gerwich, 61 years old, one of the oldest jewelers in this city, committed suicide at his home, 37 Lewis St., about 7 o'clock last evening, but the facts were suppressed by the family until this morning. Mr. Gerwich appeared to be in his usual health last evening, but a young man who called on him had only been gone a few minutes when the report of a pistol was heard in his room.

One of the family found Mr. Gerwich sitting on the lounge with blood trickling from a bullet hole over his right ear, and a 24-calibre revolver tightly clenched in his right hand. The bullet entered a little above and in front of the ear and death was almost instantaneous. Medical Examiner Fuller was called and said that Gerwich was undoubtedly temporarily insane when he committed the deed.

Mr. Gerwich was a widower and leaves a married daughter. He had been engaged in the jewelry business in this city for over 25 years. Recently he sold out his store at 324 Main St., and hired rooms in Hill's block. Since then he has appeared despondent in manner.

**Railroad Watch Inspectors Meet and Discuss Rules.**

CHICAGO, Ill., Feb. 16.—A meeting of the watch inspectors of the St. Louis and San Francisco Railroad was held at the Southern Hotel, St. Louis, Monday week, pursuant to a call issued by J. W. Forsinger, chief inspector for the road.

Those present were: W. T. Danner, Burton, Kan.; Balsey & Weir, Joplin, Mo.; Frank Clark, Springfield, Mo.; J. L. Duke, Fayetteville, Ark.; Jos. A. Droz, St. Louis; Klein & Fink, Ft. Smith, Ark.; Noyes & Huber, Paris, Tex.; C. S. Poole, Anthony, Kan.; H. W. Nunamaker, Ellsworth, Kan.; L. M. Smith, Pittsburgh, Kan.; Henry Steele, Rolla, Mo. J. L. Woolford, of Monett, Mo., wrote that his son was not expected to live and he would be unable to attend.

The meeting was called so that the details of time service might be thoroughly explained to the end that there might be a uniform application of the rules, and was not only pleasurable, but also of material benefit in furthering inspection work.



The Attention of the Trade is called to Our Line of

GENTLEMEN'S RINGS and SEALS,

with Intaglios, in Jade, Jasper and Carnelian. These goods are exceedingly desirable for this season's trade.

ALSO our full line of Misses' and Children's Rings finished in Roman.

OUR SPRING BACK STUDS, improved in construction, are now as near perfect as can be, and never so complete in variety of patterns.



Buy only the L. E. & Co. Stud.

**THE BOWDEN SEAMLESS RING**

IS MADE ONLY BY

**J. B. BOWDEN & Co.,**

Makers of Finger Rings of every Description.

**COR. BROADWAY & JOHN STREET,  
NEW YORK.**

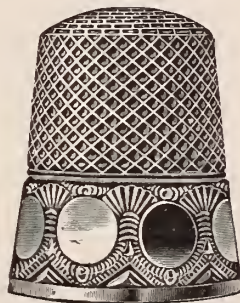

**KETCHAM & McDOUGAL**  
MANUFACTURERS  
GOLD & SILVER THIMBLES,  
GOLD COLLAR BUTTONS,  
AUTOMATIC EYE-GLASS HOLDERS  
198 BROADWAY N Y

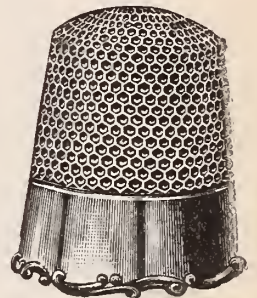

**IRONS & RUSSELL,**

(SUCCESSORS TO CHARLES F. IRONS.)  
MANUFACTURERS OF

**SOLID GOLD EMBLEMS ROLL PLATE**  
PINS, CHARMS AND SOLID GOLD RINGS.

102 Friendship Street, - - Providence, R. I.



# AUTOMATIC WATCHES

IN GOLD, SILVER and NICKEL  
CASES, HUNTING and  
OPENED-FACED,

At Half the Cost  
of Importation

Headquarters for

## Waltham Watches

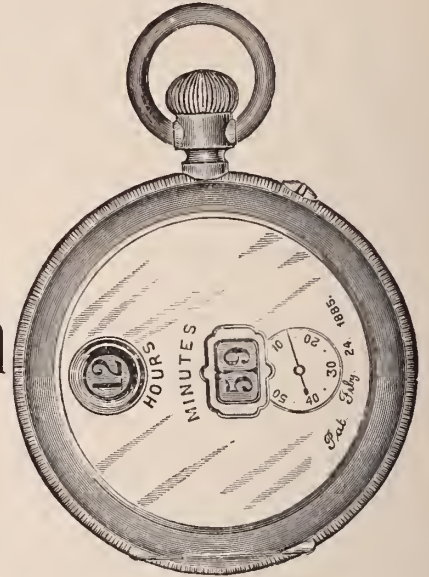
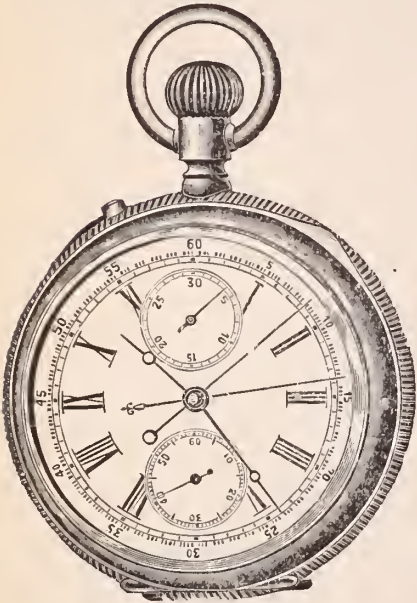

Diamonds

Watches

Silverware

Optical Goods

Tools and Materials

.... and ....

EVERYTHING ELSE NEEDED BY JEWELERS.

DAVID F. CONOVER.

B. FRANK WILLIAMS.

### David F. Conover & Co.

Chestnut and Seventh Sts.,

PHILADELPHIA.

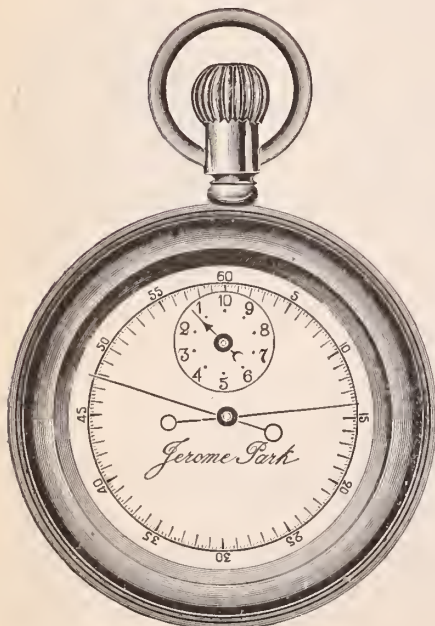



**Wallingford to Secure Another Silver Plated Ware Factory.**

WALLINGFORD, Conn., Feb. 16.—A special town and borough meeting was held last evening to act upon the question of offering inducements to secure for the town the location of the new silver ware manufactory which Henry E. Biggins, ex-superintendent of the Hartford Silver Plate Co., and others, are soon to erect. At a citizens' meeting last week, as stated in THE CIRCULAR, a resolution endorsing the project was adopted. At last night's meeting, Judge Hubbard presiding, vice-president G. W. Hull, of Simpson, Hall, Miller & Co., stated what had been done by the citizens' meeting, and advocated the movement for favorable action by the town. He called for Mr. Biggins, who stated to the meeting the intentions of the proposed new company regarding its future action, adding that naturally the Bridgeport stockholders desired to locate the plant in their own city and that inducements had been offered to locate in other places; but that he was a resident of the borough and interested in its welfare and desired that the business be located in Wallingford. He further stated that an option of a tract of land near the railroad had been secured, and an agreement reached that if the company located here that ten new houses should be erected by the company on the building lot near the factory within a space of five years; and if the action of the meeting was favorable to the request made, that work would be begun as soon as the weather would permit.

The resolution for abating the taxes of the new corporation for ten years was passed by a unanimous vote.

**Annual Meeting of the Trenton Watch Co.**

TRENTON, N. J., Feb. 16.—The annual meeting of the Trenton Watch Co. was held at the office of the company Tuesday, resulting in the election of the following directors, to serve for the ensuing year: John Moses, F. A. Magowan, Lawrence Farrell, Samuel K. Wilson and Hon. William Walter Phelps.

The annual report of the secretary showed a substantial balance over expenses for the past year's business, notwithstanding the dull times. George R. Whittaker, formerly secretary and treasurer, made an interesting address and called for a vote of thanks to the directors, and particularly to S. K. Wilson, Lawrence Farrell and John Moses, who, by their financial aid, had placed the company on a solid basis.

The jewelry store and bank of C. Parisio & Co., Hazelton, Pa., were re-opened a few mornings ago, by sheriff William Walter and the costs of the proceedings placed on the holders of the judgment note, Davidow Bros., of Wilkesbarre. Mr. Parisio will bring suit against Davidow Bros. for damages incurred by the closing of the store.

**Controversy Among the J. R. White Jewelry Co.'s Creditors.**

ROCHESTER, N. Y., Feb. 16.—In the equity term before Judge Yeoman Wednesday morning W. H. Shuart as attorney for the receiver of the J. R. White Jewelry Co., asked the court for an order permitting the receiver to accept the offer of A. T. Hagen of \$10,000 for the stock of diamonds and other jewelry remaining in his possession. The liabilities of the company are \$50,000 and the receiver's first estimate of the value of the stock was much greater than the receipts from the proposed offer and the previous sales would amount to. David Hays, Frank Goff and Isaac Adler appeared representing several creditors to oppose the motion on the ground that the stock is worth about double the sum offered by Mr. Hagen. W. M. Cogswell appeared on behalf of the Merchants' bank, another creditor, favoring the sale.

The attorneys for the creditors opposed to the acceptance of the offer said they had had no opportunity to examine the stock and assure themselves of its value. They would be just as helpless in the matter of making a counter offer had the proposition been for only \$5,000. After considerable discussion Judge Yeoman made an order that the receiver accept the proposition of Mr. Hagen, unless within two weeks he received a better offer.

**EASTERN CREDITORS OF J. R. WHITE JEWELRY CO. HOLD AN EXCITING MEETING.**

PROVIDENCE, R. I., Feb. 16.—Anyone passing the door of the Manufacturing Jewelers' Board of Trade rooms yesterday afternoon would have thought that some political faction was having a spirited meeting inside, and that the participants were indulging in exciting and fiery remarks. This conclusion would have proved erroneous, as it was only a meeting of manufacturing jewelers of this city and the Attleboros, who were creditors of the J. R. White Jewelry Co., Rochester, N. Y.

Secretary Morton in his last annual report speaks of this case as follows: "The J. R. White Jewelry Co., upon application of Mr. White, a receiver was appointed, and the several stores at Albany, Troy, Rochester, Brooklyn, Philadelphia and Baltimore, are being continued by him. 17 creditors, \$12,697.28."

A few days ago Secretary Morton accidentally learned that the business was advertised to be sold at public auction on the 14th inst. As no notification had been given to the Board of Trade of the proposed movement, Mr. Morton, through the board's Rochester attorneys, entered a protest, and the sale was postponed until Feb. 26th. A meeting was then called of the local creditors, for 2 o'clock yesterday afternoon. All of those present refuse to divulge any of the actions of the meeting, but it is stated that it is their intention to proceed against the defunct concern with the full rigor of the law.

**Easter Novelty**

BOOK MARKERS WITH FOUR (4) SOLID SILVER TOKENS, MOUNTED ON CARD BOARD WITH THE WORDS

**"EASTER GREETING"**  
STAMPED WITH STEEL DIE AT TOP.

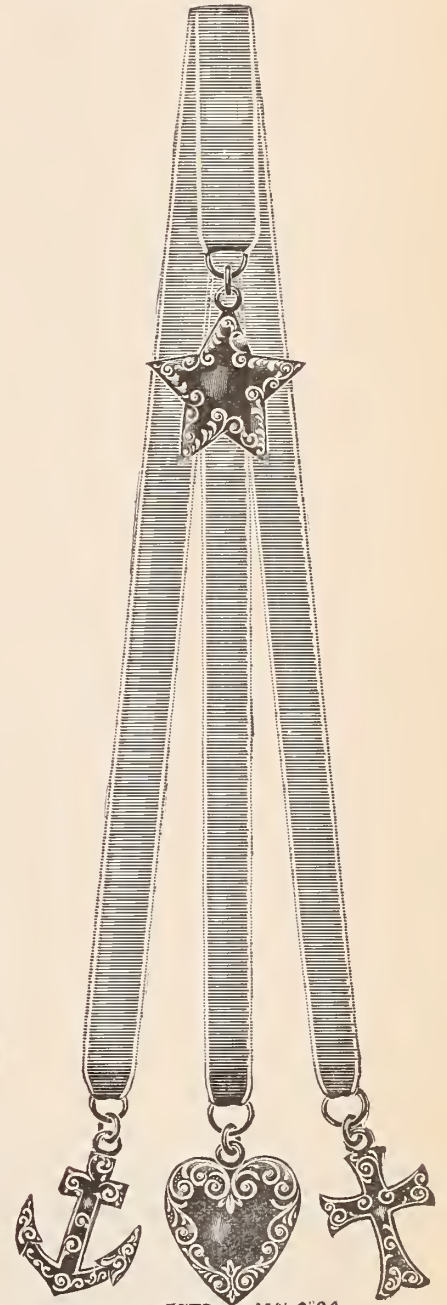

ESTD. JAN. 6 '94.

A QUICK SELLING AND POPULAR NOVELTY.

PLAIN FINISH,	PER DOZ.
EMBOSSED, SEE CUT,	\$5.00
EMBOSSED AND ENAMELED,	9.00
	12.00

SEND FOR SAMPLES.

**QUEEN & CO.,**  
1010 Chestnut Street,  
PHILADELPHIA.

### A Young Woman Works F. G. Smith, Sons & Co.

DETROIT, Mich., Feb. 19.—Saturday afternoon a handsomely dressed young woman obtained a valuable diamond pin at F. G. Smith, Sons & Co.'s store by false pretenses. The young woman claimed to be a niece of Mary E. Leggett, 645 Woodward Ave.

She selected several articles of jewelry, among them being a diamond pin, which she stated she would take with her as she desired to wear it. The other articles were to be delivered. The fraud was discovered at the house of Mrs. Leggett. The police think she is a professional confidence woman.

### Harrington & White Make an Assignment.

PROVIDENCE, R. I., Feb. 19.—Harrington & White, manufacturers, 54 Page St., have made an assignment to Julian Rathbone, gold and silver refiner. The liabilities are estimated at between \$6,000 and \$7,000 and

the assets under \$2,000. The business depression and a large number of bad debts are the causes of the failure.

The co-partnership was formed in the Spring of 1890. Andrew A. Harrington was formerly engaged in business in Mansfield, Mass. In 1888 he sold out to C. D. Lyon. After that for a number of years he was employed as traveling salesman for George H. Holmes & Co., of this city. Henry L. White is a practical jeweler.

### Silas Stuart Striken With Apoplexy.

Silas Stuart, formerly of 2 Maiden Lane, New York, was stricken with apoplexy early Monday morning at his home in Montclair, N. J. This was followed by three convulsions. There is little hope of his recovery.

Mr. Stuart is a retail jeweler, well-known in New York city. He assigned Dec. 26th to Geo. A. Miller. He succeeded the firm of Stuart & Shepard, which started in 1876 and dissolved in 1888.

Boston, Feb. 10, 1894.

We have the honor to inform you that the wholesale optical business of John W. Sanborn & Co., has been purchased by an incorporated company to be known as the

## GLOBE OPTICAL COMPANY

who will continue the business.

Mr. A. G. Barber, who has been in charge of the business of the old concern, is elected manager for the new corporation.

Thanking our customers for generous patronage in the past, we solicit its continuance in the future. An enlarged capital will, we believe, enable us to better care for all orders with which we may be favored.

Respectfully,

**GLOBE OPTICAL CO.,**

Successors to John W. Sanborn & Co.,

Wholesale Dealers in Optical Goods.

A. G. BARBER, Manager.

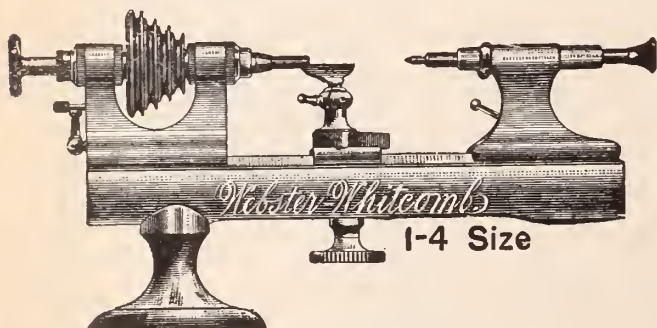

**STRONGEST GUARANTEES.**

**Quality  
Maintained.**

**Prices to  
Suit the Times.**

Ask for our New  
Prices and  
Terms for 1894.

### Columbus, O.

Veit Hirsch & Co., New York, last week brought suit against William and Abraham Kleeman and the Union Jewelry Co., asking that the sheriff be appointed receiver of the company. Since Oct. 5th the plaintiffs have taken judgments against William and Abraham Kleeman amounting in the aggregate to \$1,335.31. They say the Messrs. Kleeman have no real or personal property which can be reached by execution, so to collect their judgments they bring this action against the company. They are informed that the defendants own stock in the Union Jewelry Co. and they want to get at this stock.

Hon. George L. Converse, attorney for the receiver of the Columbus Watch Co., states that the creditors of the company will not lose a dollar; that he has asked the court for an assessment of 33 per cent. on the capital stock, but will modify this and make the sum only 30. He stated that a new company is being formed, which would buy the plant at about two-thirds of the appraised value and it would eventually pay out. Fred Lazarus last week handed Sheriff Ross a check for \$17,477.48, his share of the amount due on notes upon which his name appeared. It is thought the concern will shortly get out of its troubles.

### Louisville.

Fletcher Bennett & Co. have gone out of business.

Adam Wolf has closed out his business on Market St., at auction and has retired from the trade.

M. Walter Vowel has moved his business from Market St. near 10th to 7242 W. Market St.

James Smith last week pleaded guilty to stealing \$400 worth of gold watches from Jeweler Metteler, and was sentenced to one year in the penitentiary.

G. A. Zumar, the esteemed watchmaker at Wm. Kendrick's Sons' is near unto death. It is not thought that he will recover. Mr. Zumar is one of the veteran jewelers of Louisville.

J. Dolfinger & Co., whose store was a short time ago almost gutted by fire, reopened on the 15th with a new stock of chinaware and bric à-brac. Their store has been entirely refitted.

Traveling men in Louisville last week were: W. T. Gough, Carter, Sloan & Co.; C. A. Cuppia, Ludwig, Redlich & Co.; Monroe Engelsman, Maurice Weil; A. Pea body; Millard Veit, Marx, Veit & Co.; Fred Baker, Hayden W. Wheeler & Co.; Frank F. Gibson, Wm. Kinscherf; Mr. Bardel, Heller & Bardel.

At the meeting of the stockholders of the Mermod & Jaccard Jewelry Co., St. Louis, Mo., last week, the following were elected directors: A. S. Mermod, D. C. Jaccard, C. F. Mathey and Goodman King. The same officers were elected.

## American Watch Tool Company,

Chymistry Dist., Waltham, Mass., Stoney Batter Works.



**The Philadelphia Optical & Watch Co.  
Not to be sold at Sheriff's Sale.**

PHILADELPHIA, Pa., Feb. 19.—The effects of the Philadelphia Optical & Watch Co. will not be sold by the Sheriff, but will be disposed of by the receivers in a much more profitable manner. Thursday a petition was filed in Common Pleas Court No. 3, by the Guarantee Trust & Safe Deposit Co., asking that certain orders be made in regard to the affairs of the embarrassed concern. On January 20, Simon Muhr and James Work were appointed receivers of the company, but as stated exclusively in THE JEWELERS' CIRCULAR at the time, Mr. Muhr declined to act, and the Trust Company was named in his place. Following the attachments and executions issued on judgments entered on judgment notes the Sheriff levied on the assets.

The petition in question states that these assets are very valuable, that they will bring but a small part of their value if sold at Sheriff's sale, and that there is talk of contesting the judgments entered in court. On the other hand, the petitioners state that if the assets were sold by the receivers after due advertising, cataloguing, etc., they would bring a much better price. They therefore ask the court to decree that the judgment creditors be restrained from proceeding further on their judgments, that the property be sold by the receivers, and that the creditors upon the judgment notes and attachments should not have their rights prejudiced by such a sale.

Upon receiving this petition Judge Finletter made a decree granting the request prayed for.

**Annual Meeting of the Canadian Jobbers' Association.**

TORONTO, Can., Feb. 15.—The annual meeting of the Canadian Association of Jobbers in American Watches was held Tues-

day afternoon in committee room "A" of the Board of Trade building. Those present were: M. Schwob, J. H. Jones, Montreal; E. Scheuer, M. C. Ellis, T. H. Lee, Walter Barr, R. Gunther, A. C. Anderson, S. H. Lee, H. Ellis, W. K. McNaught and A. R. Harmon, Toronto.

The reports of the president, treasurer, and secretary were read and adopted, and sundry alterations made in the by-laws. The following officers were then elected for the ensuing year: President, W. E. Boyd, Hamilton; vice-president, J. A. Pitt, Montreal; treasurer, Sydney H. Lee, Toronto; eastern directors, A. Eaves and J. A. Pitt, Montreal; western directors, Sydney H. Lee, Wm. E. Boyd, of Levy Bros. & Co., Hamilton, and H. Ellis.

**One Partner Locks Another Out.**

LOUISVILLE, Ky., Feb. 16.—David Roth, who claims to be an equal partner with M. Lorch in the Chicago Novelty Co., has been locked out of his place of business by his partner. Lorch claims that Roth has forfeited his share in the business and that he alone has an interest in it. The men went into partnership about 18 months ago as equal partners, though Lorch put in most of the money. Roth was to make up for his lack of money by managing the business, while Lorch gave the most of his time to his jewelry business at 236 W. Market St.

The latter part of January, Roth claims, Lorch wanted to sell the place out by auction. Roth would not consent to it. A few days afterward the place was closed up on an attachment suit for \$200, brought by N. Meyer, Lorch's brother-in-law. Roth says that the Chicago Novelty Co. did not owe Meyer a cent, and that the note on which the attachment was brought was given to Meyer by Lorch without his (Roth's) signature as manager.

Mr. Lorch said to a reporter he had noth-

ing to say about the matter except that Roth had only put \$80 into the business, and had pleaded, when the attachment suit was brought, that he did not own any part of the business. He said that last year the company lost several hundred dollars, and that Roth's share in the business was swallowed up in the losses. He felt that the business was his, and that Roth, having no share in it, had no right to interfere in the way in which it was conducted.

**The Annual Dinner of the Boston Jewelers' Club.**

BOSTON, Mass., Feb. 17.—The annual dinner and election of the Boston Jewelers' Club was held at Clark's Boston Tavern, Tuesday, the old board of officers being re-elected as follows: President, Charles F. Morrill; vice-president, A. T. Sylvester; secretary and treasurer, W. H. N. Pratt; executive committee, Chas. F. Morrill, Jas. S. Blake and A. H. Pray.

The dinner was an informal affair and the members had a jolly hour after the cigars were lighted. Among other matters discussed was the subject of ladies' night, which it was decided should be celebrated in the latter part of March with a complimentary banquet, the time, place and other details to be determined by the board of officers.

**The Baird Clock Co. Incorporated.**

PATERSON, N. J., Feb. 17.—The certificate of organization of the Baird Clock Co. was filed in the county clerk's office yesterday. The capital stock is \$100,000, but the company begin business with \$50,200 paid in. It will carry on the business of the manufacture and sale of clocks in all the principal cities of this country and Europe, but the principal office will be in South Orange.

The stockholders are Edward P. Baird, Plattsburgh, N. Y.; William T. Baird, South Orange, N. J.; George F. Goddard,

THESE GOODS ARE UNRIVALLED IN LOW PRICES, EXCELLENCE OF FINISH AND ARTISTIC CONCEPTION.

\$1.90 for this Belt Complete.

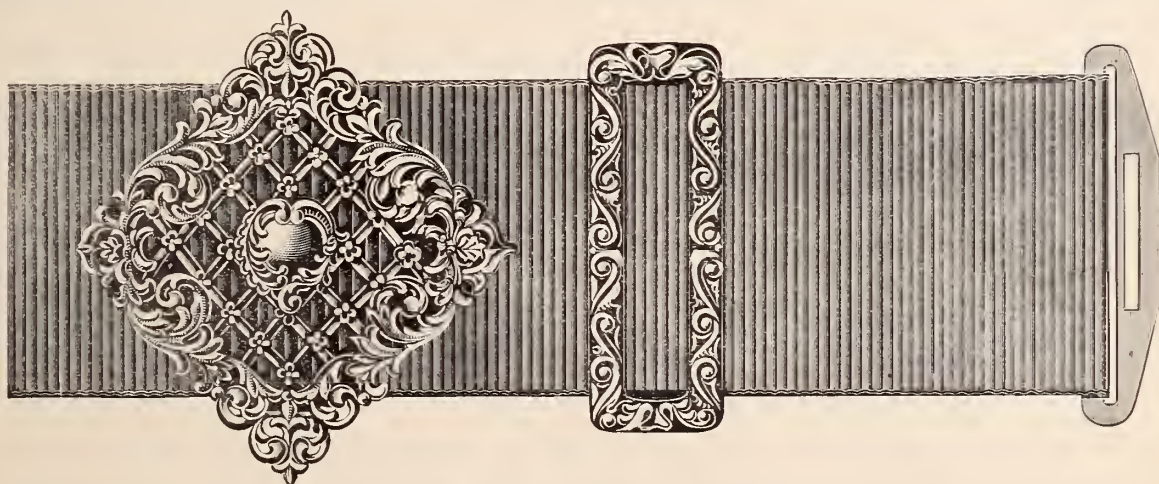

\$1.90 for this Belt Complete.

Bright Cut STERLING Silver, (no filling.) Mounted on Highest Grade of Imported Silk Webbing. An endless variety of patterns.

**JNO. W. REDDALL & CO.,**  
107 HAMILTON ST., NEWARK, N. J.

Fourteen Karat Gold, and Sterling Silver Goods of superior make and finish, at salable prices.



New York city. Edward P. Baird holds 500 shares of common stock and the other two have one share of preferred stock each.

**The Assignment of Chas. E. Udall.**

DENVER, Col., Feb. 19.—Chas. E. Udall, who conducted a jewelry business under the name of The Palace Gem Store Co., made an assignment about eight days ago to J. W. Bradley, of this city, a personal friend of Udall.

Bradley holds a chattel mortgage on the stock and now has possession as mortgagee, and Mr. Udall is engaged by him to dispose of the stock.

**Details of the Failure of Holth Bros.**

DULUTH, Minn., Feb. 17.—Holth Bros. have made a voluntary assignment to C. Schiffman. The latter has filed the schedule of assets and liabilities, the totals of which are as follows:

Assets, including stock, bills receivable, and good accounts.....	\$3,709.50
Liabilities.....	7,879.09

Excess of liabilities..... \$4,169.59

The principal creditors and the amount due each, are:

C. H. Knights & Co., Chicago.....	\$1,400
A. C. Becken, Chicago.....	615
A. E. Feddersen, Duluth.....	3,000

The balance of the creditors are all for small amounts, and are principally in Chicago and Duluth. It has not yet been decided what shall be done with the stock, but assignee Schiffman is in communication with a majority of the creditors, and the general tone of assent is for an assignee sale, all in one amount or as nearly so as convenient. The goods will probably be closed out some time next month. Holth Bros. had been in business here about three years. Ole, the senior member of the firm, has been offered a position with the Elgin National Watch Co. C. Holth has not yet decided what to do. He desires to effect a

settlement with the creditors and start in business again.

**The Good Work of Relief Still Goes On.**

The applications for relief received by the Jewelers' Relief Association continues to increase. Of all the cases examined so far, but a very few have proved unworthy. The association has found it necessary to continue giving relief to many who have been unable to secure work, and employment has been found for a few diamond setters and jewelry engravers. The fund now aggregates nearly \$6,000, but it is hoped that the amount will be materially increased. The following subscriptions were received during the past week:

American Waltham Watch Co.....	\$100 00
Alfred H. Smith & Co.....	50 00
F. M. Whiting & Co. (N. Attleboro).....	50 00
C. G. Alford & Co.....	25 00
M. B. Bryant & Co.....	25 00
Bippart & Co.....	25 00
F. W. Gesswein.....	25 00
Charles Glatz.....	20 00
Bergstein & Son.....	20 00
Jules Racine & Co.....	20 00
Roy Watch Case Co.....	20 00
A. Pinover & Co.....	20 00
Engelfried, Braun & Weidmann.....	15 00
A. Frankfield & Co.....	10 00
Max Cohn.....	10 00
B. Karsch.....	10 00
John H. Disselkoen.....	10 00
L. & J. Adler & Co.....	10 00
John A. Riley & Sloan Co.....	10 00
H. Froehlich & Co.....	10 00
J. N. Provenzano.....	10 00
Hoyt, Weller & Co.....	10 00
Deutsch Bros.....	10 00
Jos. F. Chatellier.....	10 00
H. Schenkein & Sons.....	10 00
Solidarity Watch Case Co.....	10 00
Garreaud & Grieser.....	5 00
Henderson & Winter.....	5 00
Cash.....	5 00
H. Tissot.....	5 00
Jules Gruet.....	5 00
A. Troescher & Co.....	5 00
Bachrach & Freedman.....	5 00
D. De Sola Mendes & Co.....	5 00

	\$585 00
Previously acknowledged.....	5,270 26
	\$5,855 26

**The Trade's Forum.**

AN EXAMPLE OF BRITISH ASSURANCE.

BOSTON, Mass., Feb. 6, 1894.

Editor of THE JEWELERS' CIRCULAR:

In the November number of the English *Watchmaker, Jeweler, Silversmith and Optician*, on page 310, is a paper read before the British Association meeting at Nottingham, September, 1893, by T. P. Hewitt, manager of the Prescot Watch Co., in which he describes a lathe for watch-making, and with English assurance claims it as one "that we have used" and "improvements which we have made." The entire description of the lathe, so far as we can understand his words, shows that this lathe is exactly what has been used in the Waltham watch factory for twenty-five years, and as Mr. Hewitt obtained a large amount of his machinery from America, and had access to Waltham factories, and also to the works of the American Watch Tool Co., and as A. Webster is reported to have given Mr. Hewitt a great deal of assistance in planning his factory and in building machinery for the same, it is quite fair to suppose that this is an American machine instead of one that "we" made.

It seems but common honesty for Mr. Hewitt to have given some credit for the assistance which he received from America, and we would recall to his mind the words of Lord Derby at the inauguration of his works, in which he says something as follows: "We have only to go to America to learn how our cousins make watches upon a better system." Mr. Hewitt's five or six visits to this country in line with this educational idea are well remembered by many watchmakers.

Respectfully yours,  
AN AMERICAN WATCHMAKER.

W. J. Rankin, of Kansas City, Kan., has opened a jewelry store in Westmoreland, Kan.

CELEBRATE 

Washington's



Birthdays

by ordering from your jobber a sample of the new "Charmilles" watch. First in style, first in quality first in the ranks of low priced watches.



# The Jewelers' Circular

AND  
HOROLOGICAL REVIEW.

PUBLISHED EVERY WEDNESDAY BY

THE JEWELERS' CIRCULAR PUB'G CO.,  
189 BROADWAY, NEW YORK CITY.

A JOURNAL DEVOTED TO THE INTERESTS OF JEWELERS, WATCHMAKERS, SILVERSMITHS, ELECTRO-PLATE MANUFACTURERS, AND ALL ENGAGED IN KINDRED BRANCHES OF INDUSTRY.

Our Editorial columns will contain our own opinions only, and we shall present in other columns only what we consider of interest or value to our readers. Advertising matter will not be printed as news.

Advertising rates in THE CIRCULAR are lower, considering the number of tradesmen reached by its large circulation, than in any other jewelry journal.

Notices of changes in standing advertisements must be received one week in advance; new matter can be received up to Monday.

## INFORMATION FOR SUBSCRIBERS.

### Terms of Subscription, Postage Prepaid.

	PER ANNUM
United States and Canada, . . . . .	\$2.00
Foreign Countries in Postal Union, . . . . .	4.00
Single Copies, . . . . .	.10

New subscribers can commence at any time.

Payments for THE CIRCULAR, when sent by mail, should be made in a Post-Office Money Order, Bank Check or Draft, or an Express Money Order or Registered Letter. All postmasters are required to register letters whenever requested to do so.

Pay money only to authorized collectors having proper credentials.

Returning your paper will not enable us to discontinue it, as we cannot find your name on our books unless your address is given.

In changing address always give the old as well as new one. Your name cannot be found on our books unless this is done.

We will continue to send papers until there is a specific order to stop, in connection with which all arrearages must be paid; but such an order can be given at any time, to take effect at the expiration of the subscription. All such orders will be promptly acknowledged by mail.

The Courts have decided that all subscribers to journals a responsible until arrearages are paid in full and an order to discontinue has been received by the publisher.

Member of the American Trade Press Association.

VOL. XXVIII. Feb. 21, 1894. No. 3

IN years gone by superstitious persons would have believed more strongly in the bad luck connected with the opal, if they had the evidence of two Mexicans, Prospero de la Sota and his companion, being arrested at El Paso, Tex., during their endeavors to smuggle a thousand opals into this country.

THE field of optics is becoming more and more important to the jewelry trade and the number of branches recently established by retail houses, shows that jewelers as a class recognize the field to be a profitable one.

THE recent diamond robberies in Boston were about as slick jobs as have been yet recorded, but the police do not seem to be astonished at them, as they express wonder that more bold robberies do not occur these times. Perhaps the police are a little too pessimistic in this view. All the same, it will be a good idea for jewelers to keep an eye on their diamonds and other precious but handy goods.

## TO MANUFACTURERS AND EXPORTERS.

In our opinion, the tariff agitation, notwithstanding the changes that may be effected in the Wilson Bill by the Senate, will make it necessary for our manufacturers to seek a more extensive trade than they have heretofore possessed. The export field offers this opportunity. We all recognize the countries of Mexico, Central America, Cuba and South America to be a most desirable field for American manufactures.

With a view to bringing the productions in the lines represented by THE CIRCULAR more prominently before the dealers in jewelry, etc., in these countries, we will issue between the dates of March 15th and April 1st, an Export Edition of THE JEWELERS' CIRCULAR for circulation in the above countries, including all the jewelers of Mexico, Central America, Cuba and some of the large cities in South America.

This edition will be printed, both advertisements and reading matter, in pure Spanish, and will be finely illustrated. If you desire space in this number please communicate with us at once and rates will be made known upon application. Copy for advertisements is to be sent to us in English, which we will properly translate into Spanish.

Yours truly,

The Jewelers' Circular Publishing Co.

THE JEWELERS' CIRCULAR will pay \$3 for a copy of Excelsior's "Treatise on the Balance Spring." Anyone who possesses a copy and who is willing to sell it, is requested to communicate with THE CIRCULAR at the earliest possible moment.

### Two Bills of Interest.

TWO bills providing for National bankruptcy legislation are now before Congress. One known as the Torrey Bill, is the outcome of the efforts of the merchants of the country to have enacted a law which, though just to the debtor, shall provide for the speedy and effective realization of assets and for the prevention of the many frauds at present practised under the insolvency laws of various States. The other measure, the Bailey Bill, is considered by experts as nothing more than an apology for bankruptcy legislation, finding few friends among the great body of business men. It does not appear to have been indorsed by any responsible commercial organizations, while, on the other hand, the Torrey Bill has been most carefully considered by boards of trade, chambers of commerce and exchanges in nearly all of the States, and is regarded by those who have studied its provisions, as a model of fairness to all whom it will concern, should it become a law.

### The Week in Brief.

HERMAN GERWICH, Hartford, Conn., committed suicide—The death occurred of Walter H. Eaton, Andover, Mass.—A gigantic optical goods manufacturing business is proposed for Grand Rapids, Mich.—The store of C. A. Houghtaling,

Nelson, Neb., was burned out—The estate of the late Geo. C. Shreve, San Francisco, Cal., was settled—Watch inspectors met in St. Louis, Mo.—The death occurred of Tom Anderson, traveler for M. A. Mead & Co., Chicago—The election of officers of the Meriden Britannia Co. was held—The new silverware factory in Connecticut seems to be an assured thing—S. G. Marshutz's store, Los Angeles, Cal., was burglarized—The Harrison Jewelry Co., Roanoke, Va., incorporated—Gilbert Howe, Madrid, N. Y., died—A meeting of the creditors of F. G. Smith, Sons & Co., Detroit, Mich., was held—The suit of E. G. Paine and C. E. Stanley, against the Trenton Watch Co. was tried—The death occurred of Albert H. Bradley, Chicago—Joseph Irven who endeavored to swindle several jewelers of Kansas City, Mo., was captured—J. P. Wathier & Co., Chicago, incorporated—A plan for the re-organization of the Columbus Watch Co. is on foot—Veit Hirsch & Co., New York, brought suit asking for a receiver for William and Abraham Kleeman and the Union Jewelry Co., Columbus, O.—A young woman worked a confidence game upon F. G. Smith, Sons & Co.—The A. R. Brooks Jewelry Co., St. Louis, Mo., assigned—Charles E. Udall, proprietor of the Palace Gem Store Co., Denver, Col., assigned—The schedules of Holth Bros., Duluth Minn., were filed—C. P. Morgan, Truro N. S., assigned—The Baird Clock Co., of South Orange, N. J., incorporated—The annual dinner and election of officers of the Boston Jewelers' Club were held—The annual meeting of the Canadian Association of Jobbers in American Watches was held—The effects of the Philadelphia Optical & Watch Co. will be disposed of by the receiver and not by the sheriff,



### New York Notes.

E. Lottary has obtained a judgment for \$141.07 against Eisler & Astman.

Fred L. Martin, of Eichberg & Co., sails for London on the *Majestic* to-day.

M. A. Magner has obtained a judgment for \$768.56 against Simon Dessau.

Justice Verschuur, of the Wymble Mfg. Co., sailed for Europe yesterday on the *Lahn*.

E. Scheffer, 4 Maiden Lane, has given a bill of sale of jewelry fixtures to Julia K. Scheffer for \$700.

Pepi Duckler, 148 Clinton St., has given a chattel mortgage on jewelry fixtures to J. Miller, for \$800.

Samuel Greenbaum, as assignee of C. Cottier & Son, has entered a judgment for \$4,267.24 against Chas. Seale.

The judgment for \$379.67 entered Jan. 27th, by Reed & Barton against Kathrine B. Stokes, has been satisfied.

Reed & Barton will remove their downtown office May 1st, from 18 Maiden Lane, to the store on the ground floor of 13 Maiden Lane.

Major F. R. Appleton, of Robbins & Appleton has started on a two months' pleasure trip to Italy. He sailed for Genoa, Saturday, on the *Spree*.

Jno. F. Luther, manufacturer of badges, 143 Fulton St., was slightly injured in a runaway accident at Mt. Vernon, Wednesday, while driving with his son.

H. C. Lindol has entered a judgment for \$223.40 against Abraham and Thomas Ablan. Wm. Western has entered a judgment for \$147.95 against Abraham, Howard and Tarby Ablan.

Henry C. Korler, a former clerk of Tiffany & Co., who shot himself in St. George's Church, Jan. 31st, was arraigned in the Yorkville Police Court, Feb. 13th, charged with attempted suicide. He claimed to have been suffering from the effects of the grip, and was discharged.

The appeal of John Mason from the decision of the Special Term of the Supreme Court in the suit brought by Edith M. Faxon, which set aside Mason's assignment as fraudulent and void, was argued before the General Term of the Supreme Court Wednesday. Decision was reserved.

By order of Judge Martine of the Court of General Sessions, Wm. C. Boyd, who had been confined in the Tombs, was Thursday extradicted to Springfield, Mass., to be tried for the alleged theft of jewelry from a sample trunk belonging to H. C. Barnum, traveling salesman for Shafer & Douglas.

E. A. Freeman, receiver for the E. N. Welch Mfg. Co., has decided to remove the New York store from 13 Maiden Lane. His application to Judge Robinson, of the Superior Court of Connecticut, for permission to lease a store in New York for the sale of goods for one year from May 1, 1894, at an annual rental not to exceed \$2,000, was

granted Feb. 13th. The new location has not yet been settled upon.

Ludwig Nissen & Co., composed of Ludwig Nissen and Alexander C. Chase, 18 John St., dissolved by limitation Thursday, and Mr. Chase retired. The partnership was formed five years ago. Mr. Nissen has admitted Emil Knoph and Jno. W. Ruefer as partners, and will continue the business under the old name. Both Mr. Knoph and Mr. Ruefer were formerly in the employ of the firm, the former for six and the latter for four years.

Judge Lacombe, in the United States Circuit Court, Friday, heard two motions in the suit of the Dueber Watch Case Mfg. Co. against the manufacturers of watch movements and watch cases. The first by the plaintiffs, to compel the E. Howard Watch & Clock Co. to accept an amended complaint, was granted; the second by the American Waltham Watch Co., asking that the amended complaint be struck from the file as trivial, was denied. The defendant's time to answer or demurrer was extended 20 days.

A collection of antique and mediæval gems is on sale at the library of the Charity Organization Society, 4th Ave. and 22d St. Chief among these are unset gems, scarabs, scaraboids and lockets. The donor of the collection, the proceeds of which are to be given to societies with which the Charity Organization Society co-operates, will not permit his identity to be made public. He has also given a collection of curiosities, ceramics, and antique sculpture and metal work to be sold for charity like the gems. This collection is worth several thousand dollars.

Alvis Diepenbrock and Bernard W. H. Uchtmann, composing the firm of Diepenbrock & Uchtmann, importers of church ornaments, 9 Barclay St., made an assignment Saturday to Gustave Van Sande, giving a preference to Egbert Uchtmann, of Jersey City. The assignment, it is said, was made to protect the creditors on account of an attachment obtained on Thursday against Mr. Uchtmann as a non-resident for \$6,494, in favor of Delin Frères, of Paris, against whom the firm here has a counter claim. The firm was formed in June, 1891. The principal merchandise creditors are in Europe.

Horatio N. Squire, head of the firm of H. N. Squire & Son, 18 John St., has retired from business. The partnership existing between himself and his son, George H. Squire, was dissolved Thursday and the latter continues the business under the name of H. N. Squire's Son. Mr. Squire is 73 years old, having been born at Pleasantville, Conn., July 16, 1821. He has been in the jewelry trade since 1837. In that year he took an interest in the business of his brother, Bela Squire, who had a jewelry store at 182 Bowery. Later they opened a branch at 97 Fulton St., where Mr. Squire remained for 43 years. Five years ago he

removed to 18 John St., and two years later admitted his son as a partner.

An individual bowling tournament has been started among the bowlers in the jewelry trade in the vicinity of Maiden Lane. A championship series will soon be rolled for which trophies purchased from a fund formed by a nominal assessment will be awarded. All bowlers connected with the trade are invited to join the series on or before Feb. 26th, after which the schedule of games will be arranged. Applications may be sent in care of THE CIRCULAR. Among the starters of this movement are: J. W. Woodward, Derby Silver Co.; Jno. W. Ruefer, Ludwig Nissen & Co.; Harry H. Clifford, Reed & Barton; G. E. Roll, N. H. White & Co.; Harry W. Shepard, of N. M. Shepard; W. Birmingham, Wilcox Silver Plate Co.; and L. M. Sachs, with Sol. Lindenborn.

By an order signed by Judge Erhlich, of the City Court Wednesday, in the suit of Chas. Eachold and Edward A. Miller against Chas. L. Tiffany and another, a commission has issued to Arthur G. Bill, a lawyer, of Danielsonville, Conn., for the examination upon interrogatories of Burnett C. Young, of that place, who is a necessary witness on behalf of the plaintiffs. The trial of the action is stayed until the return of the commission. The suit was brought Jan. 13, 1892, to recover \$1,000 and interest upon a guarantee given by Tiffany & Co., wherein they guaranteed to that amount the payment of all goods which B. C. Young & Co., St. Louis, Mo., should buy from the plaintiffs. The plaintiffs wish to examine Mr. Young, who is now in Danielsonville, Conn., upon the question of the sale, delivery, prices and amount still unpaid upon the goods purchased by that firm.

Patrick J. Finn who has been employed for about one year as a substitute letter carrier, was a prisoner before United States Commissioner Shields, Saturday, charged with taking packages from the mails. He admitted his guilt and was remanded to await the action of the Grand Jury, in default of \$1,500 bail. For some time complaints had been received that certain letters and packages were not being received. Watch was set, and on Friday night suspicion pointed to Finn as the guilty man. He was noticed about the place where mails were being sorted for early delivery. As he was not on duty, he was closely watched. Later he was seen to place three parcels in his pocket. He was then arrested. The packages were addressed to three jewelry houses—E. S. Johnson & Co., 26 Maiden Lane; M. Fox & Co., 1 Maiden Lane; and Rees & Yankauer, 51 Maiden Lane.

On motion of Geo. Carlton Comstock, the attorney for the defendant, Judge Andrews of the Supreme Court, granted an order requiring Black, Starr & Frost, who are suing pawnbroker Henry McAleenan in that court to recover a diamond necklace of the value of \$1,000, to furnish the pawnbroker with the name of the proposed customer that James A. Eustace had when



he took the necklace on memorandum in May, 1891. The necklace contained 105 diamonds, which weighed about 15 karats altogether. It was set in white gold with pendants attached, and was valued at \$1,000. It was delivered to Eustace, who said that he had a customer for it. Eustace subsequently pledged it with the pawnbroker, who claims a lien on it for moneys advanced. The court says that the firm must disclose who the proposed customer was, give a description of him and state his financial standing or responsibility.

**John R. Scofield Charged With Misappropriating Goods.**

Notices sent out last week by T. W. Adams & Co., 14 John St., New York, informed the trade that John R. Scofield was no longer in their employ.

A CIRCULAR reporter ascertained that Mr. Scofield is charged by his employers with misappropriating goods valued at between \$2,500 and \$5,000. Scofield's whereabouts could not be learned. T. W. Adams & Co. have placed the matter in the hands of their attorney, Brewster Kissam, to recover the goods. The attorney stated that the goods are recoverable at but little cost. Any further information at present, he said, would be prejudicial to the interests of his clients.

Scofield has been in the employ of T. W. Adams & Co. for over ten years, and enjoyed the fullest confidence of his employers. He is a brother of Edmund J. Scofield, the

former New York agent of the Elgin National Watch Co., who was removed last year, owing to a large shortage in his accounts.

**Travelers Receive an Interesting Circular From the Protective Union.**

The robbery of the trunk of H. C. Barnum, traveler for Shafer & Douglas, New York, has elicited the following circular from the Jewelers' Protective Union:

To Registered Salesmen:

In view of the fact that all registered salesmen have been instructed thus: "On arriving at their destination salesmen must at once claim their baggage."

Yet within one year two stocks have been burned, and two have been robbed, while in a Railroad Depot through the night; therefore,

The Secretary is instructed to notify each registered salesman, that should it come to the knowledge of the Executive Committee that any salesman has left his stock in a Railroad Depot through the night, such salesman's name will be immediately suspended from the Register of the Union, as was done in each of the above-mentioned cases. By order of the Executive Committee,

IRA GODDARD, Secretary.

**Assignment of A. R. Brooks Jewelry Co.**

St. Louis, Mo., Feb. 19.—The A. R. Brooks Jewelry Co. have made an assignment. The assets are about \$25,000 and the liabilities \$35,000.

**Last Week's Arrivals.**

*THE CIRCULAR has perfected arrangements for obtaining the names and hotel addresses of all the latest buyers visiting New York, and each day posts in its office, 189 Broadway, a bulletin which every member of the trade is cordially invited to copy.*

The following out-of-town dealers were registered in New York during the past week: M. V. Stone, Chicago, Ill.; Astor H.; J. A. Caldwell Jr., Philadelphia, Pa.; Murray Hill H.; E. J. Klein, Cincinnati, O.; Metropolitan H.; J. Magnus, C. W. Livingston, Chicago, Ill.; Park Ave. H.; A. Shafer, Cobleskill, N. Y.; Sinclair H.; W. W. Berry, Scranton, Pa.; Albert H.; M. King, Boston, Mass.; New Netherlands H.; Sol. Moses, Cleveland, O., 40 Thomas St.; J. McCarthy, Syracuse, N. Y.; Grand Union H.; G. Fox, Philadelphia, Pa.; Grand Union H.; J. Liefold, Selma, Ala.; Broadway Central H.; A. W. Johnson, Boston, Mass.; Astor H.; A. Wilson, Boston, Mass.; Astor H.; W. W. Frank, Minneapolis, Minn.; Belvidere H.; F. K. Potter, H. W. Ladd Co., Providence, R. I.; Normandie H.; J. R. Reed, Pittsburg, Pa.; S. Biddle, of Bariey, Banks & Biddle, Philadelphia, Pa.; Miss M. Donohue, for A. Lisner, Washington, D. C.; Belvidere H.; M. Spiesberger, Keohuk, Ia.; Belvidere H.; E. A. Buettell, Dubuque, Ia.; St. Stephen H.

**L. TANNENBAUM & CO.,**

IMPORTERS AND CUTTERS OF

DIAMONDS • AND • PRECIOUS • STONES,

Cor. Maiden Lane & Nassau St.,

NEW YORK.

25 HATTON GARDEN,  
LONDON.

TELEPHONE,  
Long Distance,  
1959 CORTLANDT

**We Offer This Week :**

Rough Siam Rubies for cutting purposes, at 50c. per karat.  
Rough Fancy Sapphires for cutting, at 25c. per karat.  
Rough Sapphires for mechanical uses, and precious stones for collectors,

ALSO, AT SPECIAL PRICES, THE FOLLOWING GOODS:

**PEARLS.**

64 Pearls, 111 3/4 grains, - at \$ .40 per grain  
31 " 108 1/2 " - - at .50 "  
12 " 101 1/4, 1-16 grains, at 1 50 "  
160 " 172 1/4, 1-16 " at .40 "

**CATS EYES.**

13 Cats Eyes, 20 karat, - at \$7.00 per karat  
5 " 10 44-64 karat, at 6.00 "

**EMERALDS.**

5 Emeralds, 105 8/8 karat, at \$15.00 per karat  
10 " 16 7/8 " at 18.00 "  
80 " 8 1/2 " at 5.00 "

**RUBIES.**

Cabochon Oriental Rubies, 39 9-64 kt., \$2.00 p. kt.  
36 " " 44 3/8, 5-64 kt., 2.50 "  
" " 61 7/8 less 1-64 kt., 1.00 "  
" " 22 5/8, 2-64 kt., 3.00 "  
278 " " 88 5-64 kt., 1.75 "  
134 Spinels, 25 5-64 kt., - - .50 "  
34 " 13 5/8, 2-64 kt., - - 4.00 "  
72 " 41 5/8, 3-64 kt., - - 2.50 "  
22 " 14 3-64 kt., - - 7.50 "  
76 Sapphires, 23 4-64 kt., - - 4.00 "

### Providence.

John M. Chandler started Monday for the west with a large line of new samples.

B. E. Daggett & Co., 119 Orange St., are succeeded by Holbrook, Daggett & Co.

B. F. Crossin, of Crossin & Tucker, has recovered from an attack of the grip and started the past week on a western trip.

Samuel H. Baldwin, of Baldwin, Ford & Co., has moved his family from New York, taking up his residence on Lennox Ave., this city.

Several manufacturers in this vicinity have been forced to discontinue operations temporarily on account of the difficulty in making collections.

Joseph Reynolds, formerly of the E. H. Reynolds Co., platers, has gone to Elgin, Ill., to take charge of the plating plant of the Illinois Watch Case Co.

The Gorham Mfg. Co.'s works started up some days ago after a two weeks' shut down, for the annual taking of stock.

The engagement is announced of George Mitchell Gier to Miss Adele Burdon. Mr. Gier has been for several years associated with the Tilden-Thurber Co. as manager of their branch store at Fall River, until the latter was abandoned recently. He will hereafter be connected with the Boston office of the Kent & Stanley Co.

Friends of George H. Thurber, the watchman who was arrested a few days ago for stealing from S. & B. Lederer and sentenced to pay a fine of \$20 and costs, visited the jail last Tuesday and paid the amount due. Thurber was immediately rearrested charged with stealing jewelry, etc. He was adjudged probably guilty, and held in the sum of \$300 for appearance before the higher court.

### Philadelphia.

Wm. Hentz's stock was damaged by fire last week to the extent of \$200.

Simon C. Levy, 1817 Ridge Ave., has recovered from a severe attack of the grip.

S. J. Downs, West Philadelphia, will spend the remainder of the Winter in Florida.

Riggs & Bros. have completed extensive alterations and improvements to the exterior of their store.

Simon Muhr has been elected one of the board of directors of the Finance Company of Pennsylvania, and of the Chestnut Street National Bank.

The Pennsylvania branch of the National Retail Jewelers' Association have issued a beautiful pamphlet containing among other matters the programme of the fifth annual meeting of the body, to be held Feb. 21st-22d.

Traveling salesmen in Philadelphia the last week were: William Parks, Parks Bros. & Rogers; Ira Barrows, H. F. Barrows & Co.; H. Ingram, Alling & Co.; and T. G. Frothingham.

A fire at 2732 N. 5th St., on Wednesday evening, caused about \$500 damage to the jewelry store of W. J. Haines. The flames originated in a store two doors below, from some cause that has not been definitely ascertained.

Herman F. Wolff last week became the amateur champion light weight wrestler of this city, as the result of a contest at the rooms of the Caledonian Athletic Club, with John Stocker. The match was in the 145 pound class.

Judgment was entered on Wednesday last in Common Pleas Court by John H. Scott against Lingg & Brother, and F. C. Lingg, 722 Pine St., on a judgment note for \$4,500, dated Nov. 1, 1890, payable in one day, and an attachment was issued summoning John D. Kennedy as garnishee.

Frank Silberman was arrested here on Wednesday last on the charge of stealing watches and jewelry valued at about \$200 from his employer, Benjamin Slavin, Newark, N. J. Four of the watches were found upon him when he was taken into custody and these he admitted were Mr. Slavin's property. He was held to await requisition from Newark. This subsequently arrived and Silberman was taken by an officer to that city.

The annual meeting and election of officers of the Jewelers' Club took place on the 13th. The reports showed the association to be in a flourishing condition, with a membership of over 80. The officers elected to serve during the ensuing year were: President, George W. Read; vice-president, Edward H. Ackley; treasurer, Henry B. Chambers; secretary, Wm. H. Long; directors, Edward H. Eckfeldt, Edward Dingee, Wm. Linker, J. Fred. Thomas and James Kelly. A meeting of the board of directors was held on Monday morning to determine plans for the future government of the organization.

## DIAMOND EXCHANGE BUILDING.

Go Let

In the new fire proof,  
ten story

Diamond Exchange Building,

14 Maiden Lane.

### OFFICES

of most modern construction, with abundance of light and air, rapid elevator, mail chute, steam heat, gas and electric light, exposed sanitary plumbing, oak cabinet trim, unique plate glass partition and quartered oak floors, at rentals from

## \$900.00

Per Annum up.

Specially adapted for the Diamond and Jewelry Trade. Possession on or before May 1st, next.

For further particulars apply to

E. A. Cruikshank & Co.,

176 Broadway, N. Y.

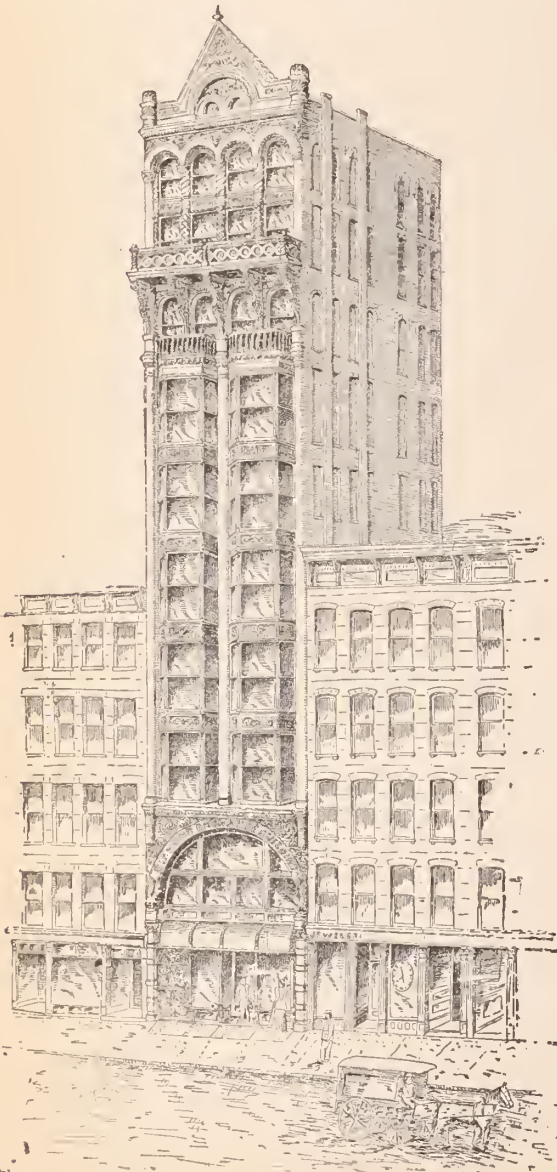

THE ELEVATOR IS NOW RUNNING.



## APPRECIATIVE PRESS COMMENTS ON THE SILVER ANNIVERSARY OF THE JEWELERS' CIRCULAR.

THE JEWELERS' CIRCULAR AND HOROLOGICAL REVIEW celebrates its silver anniversary with a number such as would be expected from this leading jewelry publication. It is replete with interesting information of the great field THE CIRCULAR so ably represents and is a gem of the printers' art. Illustrated stories by the special correspondents form a leading feature. Attention is also given the progress of THE CIRCULAR in 25 years with sketches of its managers. The house of Tiffany, the American watch, the precious stone industry, development of silversmithing are a few among the many articles which make this number especially valuable to every house and dealer in the kindred lines of the jewelry trade.—*Register Gazette*, Rockford, Ill.

THE JEWELERS' CIRCULAR AND HOROLOGICAL REVIEW, published in New York, have issued a very handsome February number in honor of their "silver anniversary." It contains an illustrated and very interesting history of the rise of the house of Tiffany and a history of American watch making. The subject of diamond cutting in America is given much space, and shows the increase in the exportation of the precious stones from 1873 to 1893 to be from \$176,426 to considerably over one million dollars a year. Jewels and the now important trade of silversmithing are entertainingly written about. The cover is appropriately an artistic bit of printing in silver.—*Star*, Kansas City, Mo.

Commemorating the beginning of the twenty fifth year of its existence, the publishers of THE JEWELERS' CIRCULAR have made the current number a "silver anniversary edition." The issue contains numerous special articles on technical subjects, written by those who are well-known as au-

thorities in their respective fields. It also contains an abundance of matter of general interest. The number is in every respect creditable to the conductors of this prosperous publication, which is recognized to be among the very best trade journals in the country.—*Bulletin*, Philadelphia, Pa.

THE JEWELERS' CIRCULAR with the current issue reaches its twenty-fifth year, and commemorates the occasion with a silver anniversary edition. The number contains numerous special articles written by the highest authorities in their respective fields, and several partake of a popular nature. Every line in the 60 pages of reading matter was specially written for this number.—*Inter-Ocean*, Chicago, Ill.

The February issue of THE JEWELERS' CIRCULAR AND HOROLOGICAL REVIEW marks the twenty-fifth anniversary of the commencement of publication of that well-known trade journal. The cover of this silver anniversary number is appropriately printed in silver and the contents are a beautiful example of latter-day typography. Both reading matter and advertisements are tully up to date, both being equally attractive and interesting.—*Dry Goods Economist*, New York.

That excellent trade publication, THE JEWELERS' CIRCULAR, with the current issue reaches its twenty-fifth year and commemorates the event with a handsome Silver Anniversary edition of 140 pages, the greater part of which consists of matter especially written for this number. It is a splendid publication and printed in the highest style of typographical art and with many appropriate illustrations.—*Daily Journal*, Meriden, Conn.

THE JEWELERS' CIRCULAR is 25 years old to-morrow, and in honor of the event a special edition was issued this month of 140 pages, beautifully printed and lavishly illustrated. There is a sketch of the career of the journal, with a fac-simile of the first page of the initial number, and the other pages are taken up with articles and advertisements of special interest to jewelers and dealers in precious stones.—*Star*, Philadelphia, Pa.

The twenty-fifth anniversary number of THE JEWELERS' CIRCULAR AND HOROLOGICAL REVIEW, of New York, has been received at this office. It is finely gotten up and contains an immense amount of matter of great interest to the jeweler, together with many short stories by THE CIRCULAR correspondents.—*Commercial*, Bangor, Me.

THE JEWELERS' CIRCULAR celebrates the attainment of the mature age of 25 years by issuing a sumptuous silver anniversary edition. This is the oldest publication devoted to the jewelry and kindred trades.—*Chronicle-Telegraph*, Pittsburgh, Pa.

THE JEWELERS' CIRCULAR has an interesting article on the Artistic Clocks in New York Palatial Hotels, with illustrations of some of those in the public rooms of the Imperial, Plaza, Savoy and Waldorf.—*The Hotel Reporter*, New York.

THE JEWELERS' CIRCULAR with the current issue reaches its twenty-fifth year, and commemorates the occasion with a silver anniversary edition.—*Evening Post*, New York.

THE JEWELERS' CIRCULAR is twenty-five years old, and appropriately celebrates the occasion by a fine special number.—*Recorder*, New York.

# OPPENHEIMER BROS. & VEITH, WATCHES AND

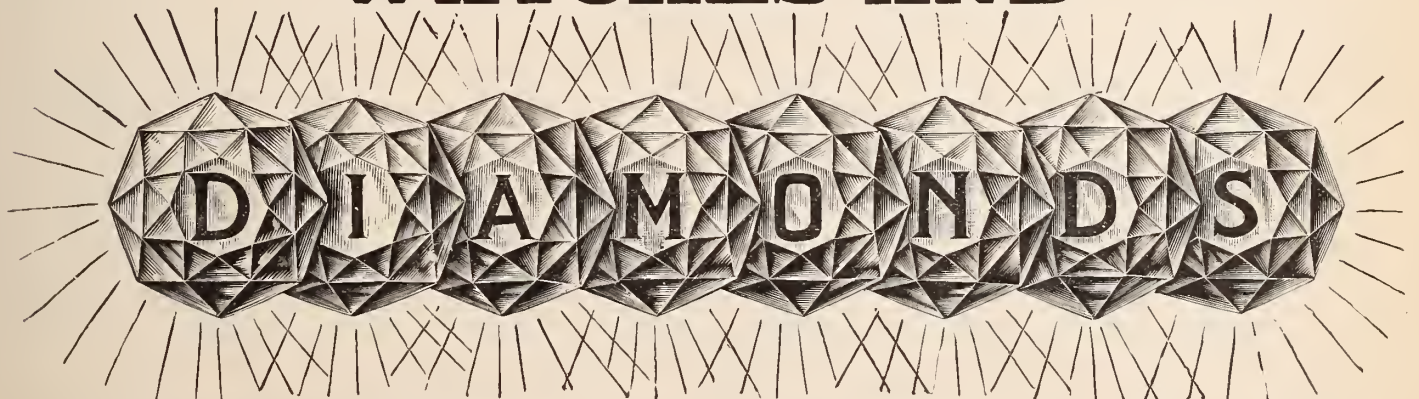

A Large Line of DUEBER Solid Gold Cases. Filled Cases. Silver Cases.  
Our Specialty: HAMPDEN MOVEMENTS, 6, 16 and 18 Sizes.

AMSTERDAM, HOLLAND, 2 TULPSTRAAT.

LONDON, ENG., 28 HOLBORN VIADUCT.

NEW YORK, 35 MAIDEN LANE.



THE WESTERN TAKES ITS WAY

# WESTERN SUPPLEMENT of THE JEWELERS' CIRCULAR

**Chicago Office: Room 308, Inter-Ocean Building.**

VOL. XXVIII.

CHICAGO, WEDNESDAY, FEBRUARY 21, 1894.

NO. 3

### Chicago Notes.

Jacob Muhr visited the Chicago office of the firm last week.

E. W. Prentiss, manager for the Gorham Mfg. Co., left for the east Thursday.

Sam Dripps, with Benj. Allen & Co., left Saturday on a trip through the south.

A. A. Bastar, jeweler, 776 W. 12th St., is the happy father of a 12-pound bouncing girl.

The Rockford Silver Plate Co. have swelled the contribution for relief work by a gift of \$25.

L. C. Garwood and wife, Champaign, Ill., will leave the present week for a three months' visit in California.

P. H. Savory left Chicago Thursday for a two weeks' visit in the larger western cities with the Brooklyn-Fahys line.

Joseph Harris, formerly with Giles, Bro. & Co., left Saturday to visit sons and daughters on the Pacific coast, till May.

C. T. Wittstein is in California on a business trip. F. R. Sheridan, representing Geo. H. Cahoon & Co., is a fellow traveler.

The junior partner of George A. Lockwood & Son, Chariton, Ia., arrived last week with a carload of sheep for the market.

C. H. Knights & Co. report a number of fine diamond sales, and say the general tone of business is considerably better than a month ago.

E. J. Hoyer, 228 N. State St., has returned from a period of recuperation at Mt. Clemens, Mich., having recovered his usual good health.

Sigmund Stein, of the Stein & Ellbogen Co., returned to Chicago Wednesday, after an eight months' visit to leading German watering places.

Benj. C. Allen, son of Benj. Allen, at the recent examination at Yale, was one of the five from Illinois who carried off the honors in the junior class.

The Christman Jewelry Co., 576 E. 43d St., have been succeeded by E. E. Dewitt. Mr. Dewitt is a practical watchmaker and was for 14 years an expert finisher in the Waltham factory.

F. J. Essig, lapidist, 1,222 Masonic Temple, was obliged to forego his contemplated California trip, owing to pressure of business at the factory. Mr. Johnson, of the firm, is looking after their California interests.

The removal of the safes and stock of the Brooklyn Watch Case Co. to the rooms of Jos. Fahys & Co. was effected last week. H. M. Ayers, formerly manager for the Brooklyn Co., will sever his connection with that concern May 1.

Paul Juergens, senior member of the Juergens & Andersen Co., accompanied by Mrs. Juergens and daughter, left Saturday for a pleasure jaunt in leading southern and Pacific coast points. The trip will take some six weeks and will include Mammoth Cave, Ky., and the Yosemite Valley.

J. P. Wathier & Co., 178 W. Madison St., have incorporated as the Joseph P. Wathier Co. for the manufacture of jewelry. Nicholas E. Wathier, Joseph P. Wathier and M. T. Wathier are the incorporators, and the company have a capital stock of \$75,000. All the members are jewelers of high standing and successful business men.

Carpenters are busy at room 402, Columbus building, on the handsome solid mahogany partition and counters for G. W. Marquardt & Sons. An elegant private office occupies one corner and a battery of five huge jewelry safes occupies one side of the large room. The handsome Chicago home of the firm will be ready for occupancy the present week.

F. W. Hall, of Buck & Hall, is visiting the trade between Chicago and San Francisco and will likely devote some time to the latter city. Mr. Hall carries a full line of Coddling Bros. & Heilbron, Peckham Seamless Ring Mfg. Co., Western Elastic Mfg. Co., Aluminum and Novelty Co. goods and has photos of a fine line of imported onyx, porcelain and cuckoo clocks, for all of which Buck & Hall, 801 Columbus building, are western agents.

At the annual meeting of the stockholders of Spaulding & Co., Feb. 14, the following officers were elected: President, Edward

Holbrook; secretary, Edward Forman; treasurer, Lloyd Milner. There were present at the meeting, Geo. H. Robinson, L. Z. Leiter, Joseph Leiter, E. J. Smith, Lloyd Milner and Edward Forman. The only change is in the office of president, Mr. Holbrook being elected to fill the vacancy caused by the retirement of Mr. Spaulding.

Severe storms throughout the week reduced the number of buyers in western trade centers, and the influx of buyers as reported in THE CIRCULAR of last week was temporarily checked. The large number of the previous week, however, is indicative that on the return of seasonable weather the country dealer will be very much in evidence among the city jobbing trade. Stocks need replenishing and good selections in all lines can better be had now than later in the season.

A. Hirsch & Co., 175 Madison St., have leased 2,000 square feet of the quarters formerly occupied by Giles, Bro. & Co., on the fourth floor of Masonic Temple, and will move into their new quarters within 30 days. The lease runs five years. S. Buchsbaum, manufacturing jeweler, 175 Madison St., takes a smaller space adjoining the new quarters of A. Hirsch & Co. About May 1st the Bradley & Hubbard Mfg. Co. will be in their new location, 203-204 Masonic Temple, and Edward Miller Co. are now in possession of suite, Nos. 808-809.

To advertise his railway watches, J. H. Hales, Little Rock, Ark., has had shipped to him one of Grout's new watch signs with engine attached. J. R. Hawkins, Mason City, Ia., a recent addition to the optical trade, ordered one of the Excelsior Sign & Mfg. Co.'s new eyeglass signs. A. P. Taliaferro, who has opened a jewelry store at Bunkie, Ala., has had forwarded one of Grout's best carved iron watch signs, and as an indication that the northwest is arousing itself, S. H. Clausin & Co., Minneapolis, Minn., dealers in watch tools and materials, have ordered from the Excelsior Sign & Mfg. Co. a line of their celebrated carved iron watch signs and handsome watch racks.



**Kansas City.**

George Hosier has returned to Cady & Olmstead's.

Charles Altschul, of Oppenheimer Bros. & Veith, New York, will be here this week.

The Jaccard Watch & Jewelry Co. are making 200 lapel buttons for the Kansas City Commercial Club.

Melville Wood has opened a jewelry store in 10th St., west of Main St. He once had a large jewelry store, and lately has been in business on South Grand Ave.

The Ferd. Heim Brewing Co. have adopted a novel and expensive form of advertising. It consists in having made a lot of solid gold watch charms, each bearing the trade mark of the company. The charms will be given to favored customers. The medals are being designed and made by the Jaccard Watch & Jewelry Co. They are a little larger than \$5 gold pieces.

A man calling himself Thomas Hamilton, went to jeweler Crider's store at Hennnessey, Okla., a few days ago and bought \$100 worth of silver. Mr. Crider did some detective work and discovered that his customer and two other men had begun operations as counterfeiters. He notified the officers but when they raided the den the men had fled. Their dies and tools were seized.

Joseph Irven, alias Charles Potter, who is said to have swindled A. L. Sanderson & Co., out of \$209 worth of silverware, and who tried to swindle the Hart Jewelry Co.

and Osborne & Pitrat, has been arrested in Chicago, whither he had fled from Kansas City, and has been brought back here. He was arraigned before Justice Worthen who fixed his bail at \$1,000, on the charge of embezzlement preferred by A. L. Sanderson & Co., and he was committed to jail in default.

C. L. Merry, manager for the Julius King Optical Co., has just concluded a very successful six days' school of instruction in practical optics. Among those who came to the city to attend it were: J. B. Lowe, Independence, Mo.; Walter Sperling, Seneca, Kan.; I. Lessem, Kansas City; H. J. Norton, Atchison, Kan.; Fritz Hoeffler, Aurora, Mo.; A. Alber, Kansas City; T. J. Ellis, Jonesboro, Ark.; E. F. Dunn, Kansas City; H. O. Bailey, Smith Centre, Kan.; S. B. May, Horton, Kan., and A. L. Grady, Slater, Mo.

**Minneapolis and St. Paul.**

A. E. Paegel, formerly watchmaker for A. Sanborn & Co., Minneapolis, has opened in business for himself at 22 3d St. S., Minneapolis.

Herman Segerstrom, for years past salesman and watchmaker for A. Sanborn & Co., Minneapolis, left last week for Helena, Mon., where he intends to locate permanently.

Kerry Conley, Spring Valley, Minn., has engaged with the Reed & de Mars Jew-

elry Mfg. Co., Minneapolis, to represent them on the road in Minnesota, Iowa and Wisconsin.

Out-of-town jewelers visiting the Twin Cities the past week were: E. C. Bennett, Red Wing, Minn.; Edward Fisher, Bayfield, Wis.; Theo. G. Mahler, Le Sueur, Minn.; Lucien Diacon, Chaska, Minn.

A bold sneak thief entered the establishment of the Reed & de Mars Jewelry Mfg. Co., Feb. 9th, and attempted to make a way with a paste board box containing seven silver watches valued at \$5 each and nine pairs of spectacles valued at 75 cents a pair. He was detected in the act. He waived examination in the Municipal Court the day following his arrest, and was bound over to the grand jury who found an indictment against him charging him with grand larceny. The trial will take place at the March term.

**Engravers' Type.**

A Rubber Type in new styles specially adapted to Engravers' use. Seven different sizes now ready.

*Minnie S. Foster*  
*Sir Walter Scott.*

Does away with all tracing. Letters are stamped upon the article in clear cut script or old English.

The outline can readily be engraved by even the apprentice.

Type made on new principle, bevel edged; alignment guaranteed.

Every Engraver should have it. Write for particulars.

WM. H. DIETZ,  
117 Dearborn Street, Chicago.

**OPTICIANS' SCHOOL.**

If you want a GOOD ROOF over your head, come to our school. We want EARNEST STUDENTS, leave the rest to us, we do not want diploma hunters.

The Chicago Ophthalmic College and Hospital,

H. M. MARTIN, M. D., PRESIDENT. 607 VAN BUREN ST., CHICAGO.  
Being the oldest and most favorably known College of Theoretical and Applied Ophthalmic Optics in America, having more thoroughly qualified opticians in the field than all other so-called schools combined.

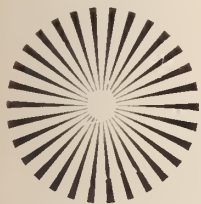

**"Best" Eye Glasses.**



The "BEST" Guard embodies some new features of great value. The lower part is rigid, the upper part is flexible. Made in both shell and cork. Must be seen to be appreciated.

Sample Eyeglass Frame, in 10k. gold,	- -	\$2.90
" " " " in Steel or Nickel,	- -	.35
Sample Pair of 10k. Gold Guards,	- -	.85
" " of Nickel Guards,	- -	.15

Geneva Optical Company,  
69 WASHINGTON STREET,  
CHICAGO.

**REED & BARTON,  
SILVERSMITHS,**

MANUFACTURERS OF

STERLING *and* SILVER PLATED  
SILVER *and* WARE.

SALESROOMS :

37 Union Square, New York.

34-36 WASHINGTON STREET,

Venetian Building, Chicago.

FACTORIES, TAUNTON, MASS.



**Death of Albert H. Bradley.**

CHICAGO, Ill., Feb. 16. — Albert H. Bradley, well known in jewelry circles, died in this city Feb. 11 from congestion of the brain, and was buried at Oakwoods Cemetery, Wednesday.

Mr. Bradley was born in New York State 68 years ago. Little is known here of his earlier life. For a number of years he was traveler for Glazer, Fifield & Co., of Chicago. In 1874 he went on the road for Benj. Allen & Co., with whom he remained ten years—five

on the road and five in the house. In 1884 he engaged in business for himself on the site of the *Inter-Ocean* building. Two years later he took charge of the Chicago office of Bates & Bacon, and was succeeded in this position a year ago by Manager Noyes, since which time he had been unemployed.

Mr. Bradley was a man of kindly disposition, sociable in friendly relations and methodical in business affairs. His good qualities were many, and he lived for others rather than for himself.

**Indianapolis.**

Horace A. Comstock left last week with his dog and gun for a hunt in the mountains of Tennessee.

Chas. Mueller, formerly watchmaker for Wm. J. Eisele, has opened a repair shop at 23 Virginia Ave.

A. J. Burns has sold out his Indiana Ave. jewelry store to his brother, Wm. F. Burns, and gone to Southern California where he will engage in the same business.

**LOOK OUT**

For our new illustrated Tool and Material Catalogue of 464 pages. It is the largest and most complete catalogue ever issued. We have made many substantial reductions in prices, and can meet the wants of every Jeweler desiring the best goods at lowest possible prices.

\*\*\* WATCH FOR IT ABOUT MARCH 15TH. \*\*\*

Should you fail to receive a copy, notify us and we will be pleased to send you one.

**BENJ. ALLEN & CO.,**  
WATCHES, DIAMONDS AND JEWELRY,

141 AND 143 STATE STREET,

CHICAGO, ILL.



One of the best of the very best.

QUALITY IS THE STANDARD OF VALUE.

CHARGES TO SUIT THE TIMES.

When interested, write your jobber for new price list for 1894, or

Moseley & Co., Elgin, Ill.



No. 2 Moseley Wire Chuck has length, strength, accuracy.



**GIBSON HOUSE,**

CINCINNATI, OHIO.

ABSOLUTELY FIRST-CLASS AMERICAN PLAN HOTEL.

\$3.00 PER DAY.

Extra Charge for Parlors and Rooms with Bath attached. The unequalled advantages in central location, liberal management, modern appointments, experienced service and perfect cuisine, have permanently established the Gibson House as The Most Popular First-Class Hotel in Cincinnati.

AMPLE VAULTS FOR THE PROTECTION OF VALUABLES.

**THE GIBSON HOUSE CO.,**

H. B. DUNBAR

President and Manager.

EST. 1870.



**DR. PETER HENRY,**  
SPECIALIST IN  
WATCH • CASE • DISEASES

Key Winders changed to Stem Winders.

Hunting Cases changed to O. F.

English Cases changed to fit American movements

Can be cured at  
53  
Longworth St.,  
Cincinnati, Ohio



The only Genuine Chuck is the TRUE One.

The only Chuck made invariably true is the Dale.

**BUY THE ONLY GENUINE CHUCK,  
THE DALE, \$1.00.**

**DUEBER-HAMPDEN WATCHES.**

The most reliable watches are the Hampden 17 Jewel. A full line of Dueber Cases and Hampden Movements. Cash buyers write us.

**BRETHAUER WATCH & JEWELRY COMPANY,**

SPECIAL AGENTS.

71 WASHINGTON ST., - - - CHICAGO, ILLS.



WHEN IN CHICAGO, VISIT THE  
**Chicago Watchmakers' Institute,**

SUITE, 1521-1523 B MASONIC TEMPLE.

A Modern Trade School for the Watchmaker, Jeweler and Engraver.

Write for New Catalogue.



R. H. Craig, Portland, Ind., has given up his jewelry business to travel for an optical firm.

Indiana dealers among the jobbing houses last week were: A. R. Cooper, Mooresville; E. M. Wilhite, Danville; J. Sherry Jones, Clayton; and A. Meissen, Cicero.

F. M. Herron began last week to strike the fire alarm bells at 12 o'clock noon. For some time the bells have been struck by the watchman in the court house tower, but the striking has been very irregular. Since Mr. Herron assumed charge the time is perfectly correct.

The partnership existing between Smith T. Nichols, Emmet Pee, Wait M. Heaton and John M. Sims, doing business as Nichols, Pee & Co., wholesale jewelers, was Feb. 5th, dissolved by mutual consent, Smith T. Nichols and Emmet Pee retiring. The business will be carried on by Wait M. Heaton and John M. Sims, under the firm name of Heaton, Sims & Co., to whom all accounts are to be paid, and who will assume all liabilities of the old firm. Elliott Sims and John Gardner will continue to represent the firm on the road. The dissolution was a surprise to the local trade. Messrs. Nichols and Pee have formed no plans for the future, but will probably not retire from the jewelry business altogether.

**Cincinnati.**

Gustave Fox is on the sick list this week. A. G. Schwab has been out on the road

and has returned. He says he enjoyed delightful sleighing, if he did not make many sales.

The John Holland Gold Pen Co. have furnished the Michigan Stove Co. with 13,000 aluminum pencils as souvenirs to their customers.

O. E. Bell & Co. will swing a new sign this week, that will be the showiest and prettiest on the street. It is a five foot bell, gold-leafed and lettered in black.

E & J. Swigart are getting out souvenir cards with graduated holes for the measurement of foreign materials. They will send them with their compliments to the trade.

H. B. Beckett, who has represented the Dennison Mfg. Co. on the road for the past 11 years, has been stationed at Cincinnati, and will make occasional visits to the Louisville house. Harvey Rahe succeeds him on the road.

Homan & Co. have shipped to Clas. Jacobs, their Chicago manager, the first output of their Spring novelties. The firm are adding a number of new lines, among which are ink-well sets, silver vases large and small, brush trays, etc.

A daring attempt was made to kidnap jeweler J. C. Wilmes' little dumb baby about 11 o'clock one morning last week, and had not the police captured the robber the crime would have been committed. After a hard chase little "Susie" was rescued from under the coat of the bold, bad man that held her in his grasp.

**CHAS. H. PFEIL,**  
MANUFACTURING JEWELER.  
Diamond Work a Specialty.

**BEST of Workmen.**  
**BEST Design Work.**  
**GUARANTEED Workmanship.**  
Send a trial order and be convinced.  
**182 State St., Chicago.**

**HUGO MUELLER,**  
**182 State St., (Room 70,) Chicago.**  
**FINE WATCH REPAIRING**  
IN ALL ITS BRANCHES.  
Work for the trade promptly executed by skilled workmen.

**PARSONS & SCHOOL**  
—FOR—  
**WATCHMAKERS,**  
**PEORIA, - - - ILL.**  
Send for Circular and Terms.  
**PARSONS & CO.**

**G.A. WEBSTER**  
42 & 44 Madison St., Chicago, Ill.  
**Manufacturer**  
AND WESTERN AGENT FOR  
E. G. WEBSTER & SON, of Brooklyn, N. Y.  
A. F. TOWLE & SON CO., of Greenfield, Mass

**R. M. JOHNSON,**  
IMPORTER OF  
**Diamonds AND Manufacturing Jeweler,**  
**67 WASHINGTON STREET,**  
ROOMS 5 & 6,  
**CHICAGO.**

MASONIC EMBLEMS OF EVERY DESCRIPTION MADE TO ORDER.  
**THE PLANCHAMP & BECKER CO.**  
Makers and Repairers of  
**WATCH CASES,**  
Gold and Silver Plating —  
— of Watch Cases a Specialty.  
UNEXCELLED FACILITIES.  
**63 and 65 East Washington St., Chicago.**

WATCH CASE MAKERS AND REPAIRERS.  
**BOLSTAD MANUFACTURING**  
**AND PLATING CO.,**  
GOLD AND SILVER PLATERS.  
DESIGNING AND ENGRAVING.  
**170 Madison Street, - - CHICAGO.**

**ENGEL'S IMPROVED PATENT RING GAUGE.** Ask your Jobber for them.

ENGEL'S RING GAUGE PAT. SEPT. 23. 90 PAT. SEPT. 1. 91 1 2 3 4 5 6 7 8 9 10 11 12 13 A.W. ENGEL M'FG. CHICAGO U.S.A.

USED BY ALL BY MAIL SAMPLE 15 CENTS. PRICE PER DOZEN, \$1.00.

25 DIFFERENT SIZES ALL IN ONE—SIZES CORRESPOND TO ANY STANDARD RING GAUGE.

**\$10.00 WORTH OF WATCHWORK DONE BY US FOR YOU**

WILL ENTITLE YOU TO ONE DOZEN RING GAUGES FREE.

**OUR WORK IS GOOD AND PRICES LOW.**

**The A. W. ENGEL CO.,** {Manufacturers, Jobbers and } 115 Dearborn Street, { Watchmakers for the Trade. } CHICAGO, ILL.

**OPTICAL DEPARTMENTS ESTABLISHED.**



AN EXPERT OPTICIAN will thoroughly establish an Optical Department in a limited number of **FIRST CLASS JEWELRY STORES**, giving his own time as promoter until on a successful basis. Will also give complete instructions in fitting to the man designed as head of the department.

**THERE'S MONEY IN IT.**

Jewelers wishing to make a special run in their optical department or establish one, will find this a rare opportunity. Your business can be increased \$1,000 to \$2,000 a month. Arrangements can be made either on percentage or salary. An unusual opportunity for a good house to

**ENTER A LUCRATIVE FIELD.**

ADDRESS **OPTICIAN, Care JEWELERS' CIRCULAR, Chicago Office,**  
**308 INTER-OCEAN BUILDING, CHICAGO.**

**The Receiver for Giles, Bro. & Co.** will forward lists of same to those desiring to bid. 26th, 1894.

will receive cash bids for its remaining stock and accounts, by departments or in bulk, and on request Bids will be received until 9 A. M. Monday, Feb. **E. A. GILES, Receiver, Masonic Temple, Chicago.**



**Rockford.**

The boiler, engine and part of the machinery of the National Cutlery Co. have just arrived from Erie, Pa.

John M. Boyd and John Hamilton who have long been on the road for the Rockford Watch Co. have resigned.

The Rockford Watch Co. have been forced to run only three days per week of late, but the cut down, it is thought, will not be for any length of time.

The Anderson Jewelry Co. have been licensed to incorporate by the Secretary of State. The capital stock is placed at \$3,000 and John Anderson, E. R. Wallborg, and S. G. Johnson are the incorporators. This step simply makes the firm of Anderson & Co. a corporation. There will be no change in the management.

**Pacific Coast Notes.**

Mr. McManus, Ventura, Cal., is confined to his home by illness.

Mr. Titus has opened a jewelry and optical goods store in Pomona, Cal.

A jewelry store has recently been opened in National City, Cal., by A. J. Arnold.

F. J. Carter, of Armer & Weinshenk, San Francisco, is spending some time in Los Angeles, Cal.

A new jewelry store has been opened in Santa Monica, Cal., by R. H. Witheril, who formerly kept a jewelry store in Tehachapi, Cal.

J. S. Baker, watchmaker, and B. F. Muller, jeweler, have rented a room in Riverside, Cal., and have opened a jewelry store.

Joseph A. Winslow, an old established jeweler of Phoenix, Ariz., has closed out his business in that city and resumed it in Globe, Ariz.

The California Guarantee and Trust Co., San Francisco, in which M. J. Morley, jeweler, was secretary and general manager, have failed.

Arthur Everitt, Albuquerque, N. M., has put Frank R. Coe in charge of his branch store in Needles, Cal., in place of D. B. Bryan, the former manager.

C. F. Kammen, public administrator of

San Diego, Cal., has sold at public auction, the entire stock of jewelry belonging to the estate of James Tromsell, jeweler.

Hoye's jewelry store, Sangor, Cal., was destroyed by fire a few days ago. The amount of loss is not known. The fire is thought to have been of incendiary origin.

Arthur Bob, Vallejo, Cal., has been adjudged insolvent. The sheriff was appointed receiver and all the personal property exempt from execution was set upon for the insolvent. The assets lack much of being an offset to the liabilities.

Mrs. Louise Faessler, who gained so much notoriety in Oakland, Cal., a few days ago by horsewhipping her husband, William Faessler, jeweler, has been arrested at the instance of her husband on a charge of insanity. A commission was unable to say that she was insane, so they would not make an order committing her to an asylum. It was decided, however, to let her remain in jail one week in order that she might think over the situation.

M. German, 320 S. Spring St., Los Angeles, Cal., has on exhibition in his window, three souvenir spoons, designed by himself. One has a silver handle of twisted wire, surmounted by a Mexican silver coin; the bowl is gilt. The second is characteristic of California. The third is a tiny spade shaped spoon, having a gold bowl with handle of twisted silver wire, with a nugget of gold on the top. The bowl also has in it a nugget of gold. This is simply a spoon in shape, but is supposed to be used as a badge or pin.

The Pacific Optical Co., Los Angeles, Cal., S. G. Marshutz, proprietor, was robbed one night last week of about \$1,000 worth of stock, consisting principally of gold rimmed eyeglasses. The thieves secured an entrance by removing a pane of glass from the skylight, then lowering a boy down between the iron bars, two of which had been wrenched apart. After being lowered to the floor the bolts of two heavy back doors were shot back and the thieves admitted. They had evidently looked over the ground and knew just where the most valuable goods were kept. They went directly to the show cases containing the expensive articles, which they took, leaving the cheap goods behind. A private watchman and one policeman were on duty on the block, yet the robbery was not discovered till the store was opened next morning. The police have obtained no clue as yet.

Homer Allison has purchased his father's interest in the jewelry firm of J. W. Allison & Son, Mercer, Pa., and the firm is now Allison Bros.

... THE ...

# American Horological Institute

AND TECHNICAL SCHOOL OF LANCASTER, PA.,  
LATE OF PHILADELPHIA, PA.,

A Trade School where Watchmaking is taught practically. We do not manufacture

❁ BICYCLES OR DYNAMOS ❁

at this institute. We confine our work strictly to WATCH WORK and its kindred branches, which include

== Engraving, Jewelry Work and Optics ==

One tuition pays for all the branches. We do not have boy instructors at this institute, all men of years of experience. Each department has its separate instructor. Our institute is open for inspection. We kindly invite you to visit us and inspect our school modes of giving instruction and the progress that our students make by giving them practical instruction.

**THOMAS PENDERGAST,**  
PROPRIETOR AND MANAGER.

## PATENT FIBRE-FACED HAMMERS.

5 oz. for Watchmakers.  
10 oz. for Manufacturing Jewelers.  
Price 50 Cents Each.

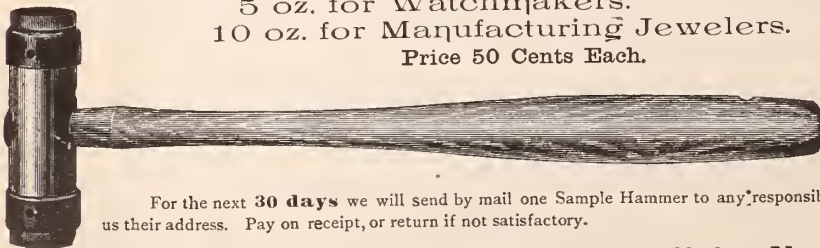

For the next 30 days we will send by mail one Sample Hammer to any responsible firm, giving us their address. Pay on receipt, or return if not satisfactory.

**W. W. OLIVER, Sole Manufacturer, - Buffalo, N. Y.**

Send for our No. 10 Catalogue.

**ELGIN HOROLOGICAL SCHOOL,**  
THOROUGHLY PRACTICAL.  
COMPETENT INSTRUCTORS.  
Send for Prospectus.  
**ELGIN, ILL.**



Tortoise Shell

... WITH ...

Sterling Silver

Deposit.

Extensive Lines

... OF ...

Hair Ornaments,  
Lorgnettes

... AND ...

Other  
Novelties.



HIGHEST AWARD, WORLD'S FAIR,  
CHICAGO.

Rice & Hochster,

TRADE MARK

Manufacturers of

TORTOISE

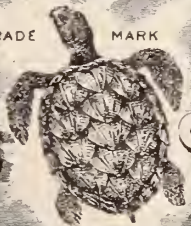

SHELL

GOODS

483 & 485 Broadway,

New York.

### Trenton Watch Co. Put in a Defense in a Suit Against Them.

TRENTON, N. J., Feb. 15.—The suit of Edward G. Paine and Charles E. Stanley against the Trenton Watch Co., for failure to carry out the agreement under which they came on from Ohio to work for the company, came off at District Court yesterday. The deposition of superintendent Roswell Moreland was read, as was the correspondence between him and the men which led to their coming.

It was claimed the men, who are expert pivot turners, understood from the letters they received that they were to have work from July 24th, and were to be furnished with 400 to 500 pivots a day at \$2.75 per hundred. Lawyer Sanford, for the men, held that if any ambiguity existed in the agreement, the plaintiffs were entitled to the benefit of the doubt. They were employed from Oct. 2d to Dec. 23d.

John Moses, one of the directors of the company, when placed on the stand said that Mr. Moreland had no authority to employ special men for special work. He knew that the foreman whom he succeeded was discharged for making contracts. Moreland himself was only employed from week to week. Mr. Moses alleged that the change in the watch, which led to the employment of the two men, was made by Moreland without consulting with any of the directors and without their knowledge, and increased the expense without increasing the selling price.

Arthur Moses, secretary and treasurer, testified that he paid the men each week, and when the works closed in December gave them checks stating that they were in full payment of wages. No protest was made. Lawyer Sanford observed that if the company tried to prove that the men had waived their rights to the terms of the contract, it would be acknowledging the existence of a contract. Decision was reserved.

### The Clocks of the Nashville Electric Clock Co. Ordered Down.

NASHVILLE, Tenn., Feb. 16.—The Board of Public Works and Affairs received a report from the city electrician this week relative to the wires of the defunct Nashville Electric Clock Co. These wires were found to be lying across electric light wires at the corner of Cherry and Broad, College St. at Union, at Loveman's store on College St., at the corner of Union and Market, on south side of the square and between Market and Front Sts. All these wires have been properly attended to.

The electrician found that no one was in charge of the electric clock property. It is probable that the board will order all the clocks to be taken down at once.

### A Jeweler's Wife Narrowly Escapes a Horrible Death.

TAMPA, Fla., Feb. 15.—Mrs. W. J. Dombrowsky, wife of the Franklin St. jeweler, very narrowly escaped a horrible death on Thursday last, at their residence on Hyde

Park Ave. Early in the evening, and before Mr. Dombrowsky came home, Mrs. Dombrowsky was about the gasoline stove. She was alone with her sister and children, and none of them can tell whether the stove exploded or how it came about. The first she knew the fire flared up, setting her clothing on fire. She ran out screaming, when a man who happened to be passing, ran in and put out the flames, but not before she was seriously burned. He also put out the flames in the room before the arrival of the fire department.

### Leaves the Jewelry Trade for the Pulpit.

MANCHESTER, N. H., Feb. 19.—Rev. Charles F. Elliot, who for some time has been engaged in the jewelry business in company with his father, William H. Elliot, at 845 Elm St., has severed his connection with the firm to become the pastor of the Unitarian church at Hinsdale, Ill., one of Chicago's most beautiful suburbs.

Mr. Elliot was originally of the Universalist faith, having received his education at the St. Lawrence University. Before coming to this city to become his father's partner, he very acceptably filled pulpits at Jacksonville, Mich., and Janesville, Wis.

G. W. Kennedy will open, this week, a jewelry establishment at 502 Walnut St., Des Moines, Ia., making a specialty of bric-à-brac and diamonds.

Burglars last week entered the store of James Bailey, Lyons, Ia., and among other plunder secured eight gold watches.

# ROGERS, SMITH & Co.

UNION SQUARE,  
NEW YORK.



CARD CASE AND WHIST COUNTER.

MERIDEN,  
CONN.

# GOLD AND SILVER PLATE.



**Connecticut.**

Charles A. Peck, Bridgeport, was united in marriage last week to Miss Harriet Hubbard, of Danbury.

H. J. Whimby, manager of Simpson, Hall, Miller & Co.'s Montreal store, is in Wallingford for a short stay.

A. L. Collins, president of the Meriden Cutlery Co., has just purchased the Bradley block in Meriden for \$6,000 as an investment.

The application of Louis Hahn, New Haven, for benefit allowance from his insolvent estate was denied by the probate court at the adjourned hearing last week.

The petition to the Senate asking that the duty on diamonds and other precious stones remain as it is, was circulated in New London, by S. Silverthau's Sons, being universally stgned and was then circulated in Hartford with like result.

H. F. Macomber has purchased the bankrupt stock, fixtures and good will of the estate of Louis Hahn, New London, and has taken possession of the property. He will have associated in its ownership A. W. Strauss, of Boston, his brother-in-law.

George J. Strobel, of Waterbury, who has been abroad in the interests of the Waterbury Watch Co. since the latter part of December, is home again. During his stay in Europe he visited Germany, France, Holland and England. He will go west in a few days.

Mrs. Chauncey Goodrich, aged 70, who died at the home of her daughter in New Haven, recently, was the widow of Chauncey Goodrich, who was for years a successful and wealthy manufacturer of clocks and later an inventor of mechanical toys.

At the annual meeting of the Maltby, Stevens & Curtiss Co. held Feb. 13th, the following directors were chosen: D. F. Maltby, Franklin Farrell, S. J. Bryant, L. T. Wooster, W. H. Wooster, J. C. Maltby. The officers of the company are: D. F. Maltby, president and treasurer; Julius C. Maltby, secretary and general manager.

The Waterbury Watch Co. have presented a gold watch, the Wm. Rogers Mfg. Co. a silver cup, and the Meriden Britannia Co. a tilting ice pitcher as prizes to be competed

for at the annual meet of the Connecticut Brigade Signal Corps, in New Haven, Feb. 22d.

President J. D. Bergen, of the J. D. Bergen Co., of this city, is in Washington, whither he has gone as one of a committee of three deputed to urge upon the Senate that the present duty of 60 per cent. on cut glass be retained, instead of reducing it to 35 per cent. as provided by the Wilson bill.

Samuel Dodd, Walter Hubbard and Geo. M. Curtis, Meriden, have just been re-elected directors of the Meriden Gas Light Co., and Geo. H. Wilcox, Chas. Rockwell and E. B. Cowles, directors of the New England Brownstone Co., Mr. Wilcox later being elected vice-president of the company; Mr. Cowles, secretary, and Mr. Rockwell, auditor.

As the janitor entered the basement of

the George H. Ford Co.'s store, New Haven, Feb. 12th, he found that there had been a fire there which had blazed away considerably, and that it had been extinguished by the automatic fire extinguishers which were still working. When the flames had created heat enough the sprinklers got to work. By this agency no doubt a serious fire was averted. The fire started between two tables, one of which was destroyed.

The annual meeting of the stockholders of the Meriden Britannia Co. was held Feb. 15, when officers were elected as follows: President, George H. Wilcox; vice-president, F. P. Wilcox, of New York; secretary, George Rockwell; treasurer, George M. Curtis; directors, G. H. Wilcox, G. M. Curtis, J. M. Harmon, George Rockwell, D. B. Hamilton, Waterbury; F. P. Wilcox, New York; C. Bery Peets, New Haven; H. J. Lewis, Stratford; G. P. Davis, Hartford.



FINEST QUALITY ALL SILK WEBBING, \$2.00.

WE ARE THE ORIGINATORS OF THIS STYLE OF BELT AND WE PROPOSE TO HOLD THE TRADE ON THEM.

We claim that our line of Belts (55 different patterns) are all original and artistic in design, and of best workmanship and finish, and we guarantee them to be much cheaper than any sterling silver Belts made.

**UNGER BROS.,** Makers of Fine Jewelry,

In 14 kt. Gold and Sterling Silver, (.925 Fine,) at Salable Prices.

192 BROADWAY, NEW YORK.

**The "Bryant" Rings.**

Are widely advertised and will sell when anything will, therefore every Retail Jeweler should buy them.

IF NOT CALLED UPON BY OUR TRAVELERS ORDER DIRECT FROM

**M. B. BRYANT & CO.,** 10 MAIDEN LANE, N. Y.

OLDEST RING MAKERS IN AMERICA.





### Trade Gossip.

Some specially good patterns are to be found in the latest assortment of the popular 8 karat rings made by E. L. Spencer & Co., Providence, R. I.

The line of novelties offered by the Pair-point Mfg. Co., New Bedford, Mass., is extremely varied and contains many very good and popular pieces. Every dealer should see it.

J. B. Humphrey, 383 Washington St., Boston, Mass., is constantly receiving, from all parts of the country, stones to be recut and repaired. His work invariably gives satisfaction.

The Waite, Thresher Co., Providence, R. I., are receiving many duplicate orders for their line of plump 8 karat rings to which they are constantly adding new styles. The

line of gold link buttons made by this house has also proved very popular.

The new pattern of the Wm. Rogers Mfg. Co., Hartford, Conn., will be known as the "Ormonde," and will be ready about March 1st. It will be made in tea, table and dessert spoons, medium and dessert forks, butter knife and sugar shovel. The pattern is handsome and will doubtless achieve the success it deserves. A handsome calendar, bearing an excellent picture of president Wm. H. Watrous' naphtha launch, will be sent upon application.

David F. Conover & Co., Philadelphia, Pa., announce themselves as headquarters for Waltham watches, diamonds, jewelry, optical goods, silverware, tools and materials, and everything else needed by jewelers. A special drive is being made just at present in automatic watches, in gold,

silver and nickel cases, open face and hunting case, at one-half the cost of importation. With these facts in mind, it is easily understood that business with this firm is good.

Foster & Bailey's magnificent line is well announced in their attractive pyramid on another page. The dealer who hasn't inspected their goods has missed many good sellers. The line of gentlemen's chains and ladies' chain bracelets made of 1-10 gold stock has proved remarkably popular. Each joint is soldered with gold and each chain or bracelet will assay more than 1-10 gold. F. & B. is the trade mark of the firm.

If perfect workmanship, superior finish and artistic designs combined with low prices are qualities which will make a line a "seller" among jewelers, the popularity of the sterling silver novelties of Jno. W. Reddall & Co., 107 Hamilton St., Newark, N. J., is accounted for. Chatelaines, suspenders, hair pins and belts are among their principal specialties in this line, of which they are showing a large and rich variety. An artistic conception is to be seen in their Mercury wing hair pins which are proving to be among the best selling novelties they have ever introduced.

The Adelphi Silver Plate Co., 62 John St., New York, with western office at 211 State St., Chicago, Ill., under the management of L. Seligsberger, and factories at 124 to 130 Pearl St., Brooklyn, N. Y., are composed of practical men brought up in the silver plated ware industry. The business is being steadily increased year after year, largely owing to the fact that new and original patterns are constantly being produced, which, thanks to the improved and special machinery contained in the factory, are put on the market in very large quantities, perfect in workmanship and at a very low price. The best efforts of the company are constantly bent toward the production of taking and popular goods; hence their success.

The following letter received by Emile Brunor, the publisher of the Practical Electroplater, speaks for itself:

NORTH ATTLEBORO, Mass., Feb. 2, 1894.

MR. EMILE BRUNOR, NEW YORK.

DEAR SIR:—I have received the Practical Electroplater, which I had subscribed for, and was so interested in it that I remained up until 2 o'clock this morning reading it. My curiosity was aroused to see what my confrere, Martin Brunor, would say about the trade and how much there was in his book that was new to me. My shop is, I believe, the most complete in the United States for gilding, shading, oxidizing, nickel plating, electroplating, acid coloring and pyro-electro-alloygilding. Yet I am forced to admit, in answer to your inquiry, that I have found in this book many new, direct and quick methods described which will add generally to the facilities of my shop. The book produced by your father is a good one and will be of great service to the trade. You will probably not hear this from many in the trade, because being in the trade yourself, they will be slow to give a competitor any recommendation, but as a friend of progress, I am anxious to see the best methods used by all the trade, and therefore congratulate you upon the value of your book and trust that you will have the greatest success with it.

Yours respectfully,  
JOHN P. BONNETT.

## DIAMONDS.

# Wm. S. Hedges & Co.,

## Importers of Diamonds,

And Manufacturers of DIAMOND JEWELRY.

170 Broadway, New York.

22 Holborn Viaduct, London.

## R. A. KIPLING,

Importer of

# PRECIOUS STONES,

21 & 23 Maiden Lane,

19, RUE DROUOT, New York.  
PARIS.

# CALIFORNIA MIDWINTER FAIR.

## Novelties

IN

Sterling and Plated  
Souvenir Spoons, Silver  
Plated Trays, Match Boxes,  
Paperweights, Charms, Sleeve  
Buttons, Rings, etc., etc.

# Julius Eichenberg,

174 Weybosset Street,  
Providence, R. I.

## Alfred H. Smith & Co.,

### IMPORTERS

# DIAMONDS

AND

## PRECIOUS STONES,

182 BROADWAY, COR. JOHN STREET.

NEW YORK.

33 Holborn Viaduct, London, E. C.



Elk, Shrine and Masonic  
Emblems a specialty.

Badges of Every Known Order.

G. A. SCHLECHTER,

Manufacturing Jeweler.

READING, PA.



**Fashions in Jewelry and Silver-ware.**

**A LADY'S RAMBLES AMONG THE JEWELERS.**

Huge twisted silver rings are made to hold towels.

Enamel tablets are the latest development for the chatelaine.

New loving cups have spiral handles; these are very ornamental.

Graceful watering pots of silver, are to be used as vases for flowers.

Prince of Wales feathers in silver are entering a bid for popularity.

The wreath as pin and chatelaine is putting on new leaves for the Spring.

Standards of perforated silver are made to hold fan screens for lamp or fire.

A new silver key ring is a key with a handle large enough to hold other keys.

The chameleon, which in its live state has been the latest fad, is seen now in decorative silver.

Oval platinum sleeve buttons, highly polished, with a raised broken edge of gold, are new and chaste.

Perforated silver balls in Indian workmanship are seen on ivory rings and are intended to amuse the baby.

Silver cribbage boards are shown with small drawers for the cards. Silver checker boards have red and blue spaces for checkers.

In England, the new Order of the Opal, a society designed to discourage superstition, will doubtless give new vogue to the stone, which is its badge.

The sword will keep its popularity for the next season. None of the new swords are prettier than those with the twisted enamel handles. All swords of value should have a guard. The hilt makes them top heavy and they easily come out without some precaution.

It is safe to say that the life of the man who carries an umbrella now prominently exhibited will not be worth having. It has a handle of mounted gold. Around this a snake is wound, whose eye is a tremendous solitaire diamond. Another great diamond is sunk in the top of the handle. The ferrule is of gold and this has a large diamond just below the silk. Queen Victoria might carry such an umbrella when she goes shopping, but even she would need the Guards as an escort to keep away thieves and sand-baggers.

ELSIE BEE.

The dealer who desires to be well posted on watch materials, watch tools and jewelers' findings, will find no work in existence that so fully meets every want as does the new material catalogue of Benj. Allen & Co., Chicago. The user of these goods should make it his first duty to see that his name is placed upon the mailing list of this firm. The catalogue is a handsome cloth-covered book of 464 pages, size 8x10½ inches,

ESTABLISHED 50 YEARS.

**RANDEL, BAREMORE & BILLINGS,**

IMPORTERS OF

**DIAMONDS,**

AND OTHER PRECIOUS STONES.

**FINE PEARLS A SPECIALTY.**

MANUFACTURERS OF

**DIAMOND JEWELRY,**

IN THE LATEST DESIGNS.

**Diamonds Recut in Modern Styles or Repaired on Premises.**

58 Nassau Street,  
29 Maiden Lane  
NEW YORK.

1 Tulp Straat,  
AMSTERDAM.

1 St. Andrews St.,  
Holborn Circus,  
LONDON, E. C.



TRADE MARK.

ESTABLISHED 1841.

**CARTER, SLOAN & CO.,**

**MANUFACTURERS OF GOLD JEWELRY,**

No 15 MAIDEN LANE,

NEW YORK.

A. CARTER, JR.  
A. K. SLOAN.  
C. E. HASTINGS.

GEO. R. HOWE.  
WM. T. CARTER.  
WM. T. GOUGH.

FACTORY, NEWARK, N. J.

**JOHN N. DISSELKOEN,**

Cutter and Importer of

**DIAMONDS**

FACTORY.  
76 LANGELEEKERSPAD  
AMSTERDAM.

19 East 16th St.,  
NEW YORK.

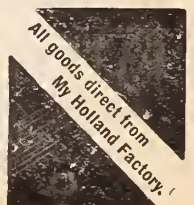



printed on delicately tinted paper, and comprises everything in the tools, material and findings lines that one could ask for, with reduced prices for each article—in fact, shows all the latest as well as standard goods at uniformly lowest prices. The arrangement is perfect. This work is alphabetically arranged, and copiously indexed. It is the largest tool and material work ever presented to the jewelry trade—a *vade mecum* of everything desired—and the prices will surprise and please you. The book is now in press and will be sent on request as soon as issued.

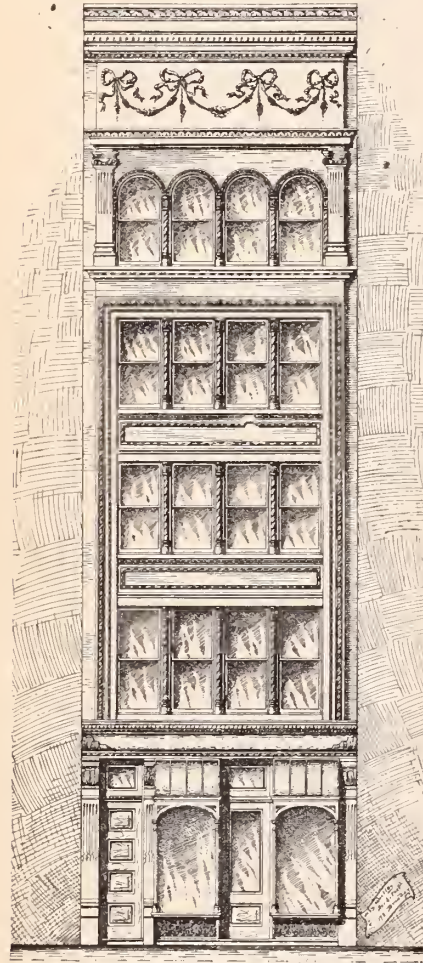

**TO LET**

IN THE

**HANDSOME NEW OFFICE BUILDING  
45 MAIDEN LANE,  
STORE 130 FEET DEEP.**

Excellent Light Throughout at Reasonable Rent, also OFFICES Light and Cheerful, with elevator, steam heat, electric light, best of plumbing and all modern conveniences, at rentals from \$350 up. For further particulars, apply to

**E. A. Cruikshank & Co.,  
176 BROADWAY N. Y.**

**PATENTS SECURED WITHOUT  
FAIL OR DELAY.**

Send Rough Sketch or Model and I will tell you whether you can obtain a patent, WITHOUT CHARGE. Fifteen years' experience. Ample references. Address

**C. T. BELT,  
WARDER BUILDING, WASHINGTON D. C.**

**Detroit.**

R. J. Roehm has recovered from a severe attack of the influenza.

J. S. McGlaucklan, Wyandotte, and William Ambler, Northville, were the only Michigan country jewelers here last week.

Geo. L. Lowe, traveling salesman for Kennedy & Koester, started last Monday for a trip through northern Michigan.

Just before Christmas the wholesale house of J. P. Johnson, Kalamazoo, Mich., was robbed of considerable jewelry. Jesse Wilson was arrested. He was last week bound over for trial.

Keith Hacker, the silverware thief whose arrest was brought about by information furnished by L. B. Colwell & Co., refiners,

was examined last week and bound over for trial. Bail was fixed at \$1,000.

Mrs. Kay, mother of John, William and David Kay, of Wright, Kay & Co., who was recently reported in THE CIRCULAR as seriously injured in a buggy accident, is on the road to recovery. She is 64 years old.

Mendall Felstein, a watch peddler, 244 Gratiot Ave., has been missing for over a week. He left the store as usual to ply his vocation. He is over sixty years of age, and it is feared some harm has come to him.

A meeting of the creditors of F. G. Smith, Sons & Co., was held here, Monday, Feb. 12th. Owing to the small number in attendance no definite settlement of the affairs of the concern was reached. It was an informal meeting, and another will probably be held later.

**ENGLISH HALL MARKED STERLING SILVER NOVELTIES.**

**Scent Bottles, Scissors, Toilet Articles and Easter Goods**

IN LARGE VARIETY.

**BACHRACH & FREEDMAN,  
SILVERSMITHS,**

**3 UNION SQUARE, = = NEW YORK.**



FULL SIZE NEW ROCOCCO.

**THOMAS W. LIND, Manufacturer of Jewelers' Findings,**

**67 FRIENDSHIP STREET, PROVIDENCE, R. I.**

Call or send for samples of my New ROCOCCO PATTERNS, for Picture Frames, Cane Heads, Whips, Boxes, Napkin Rings, etc.

Large Assortment of TRIMMINGS for Millinery Ornaments, Scarf Pins, etc



355 Mulberry Street.

IN GOLD AND SILVER.

Newark, N. J.



**Pittsburgh.**

C. H. Adelman will remove from 246 to 240 Fifth Ave.

L. Smith went east last week on business and pleasure combined.

G. L. Ruff, with I. Ollendorf, will go into business for himself after April 1.

H. Ginsburg will open a jobbing house, and discontinue his retail business.

Leo G. Weil, formerly of 970 Liberty St., is now in the employ of Emanuel DeRoy.

Mr. Bihlman, formerly with K. Smit, is now with Emanuel DeRoy, as watch-maker.

The jewelry department of Fleishman Bros. will be discontinued after the stores are formally re-opened.

Solomon & Ruben, Smithfield St., have opened a jewelry department, which will be in charge of Grafner Bros.

J. McKibben, East Liverpool, O., who was closed out by the sheriff, has resumed business opposite his old stand.

I. Ollendorf is busily engaged in closing out his stock and fixtures, preparatory to moving to 45 Maiden Lane, New York.

M. Blank and Grafner Bros. had small fires in their respective stores last week; the losses were fully covered by insurance.

R. Seigleman, Homestead, Pa., was robbed of \$1,000 worth of diamonds in broad daylight. The robbers are still at large.

The firm of Jos. M. Schaefer & Co. have dissolved, J. W. Furnee and M. Terheyden retiring from the firm, but remaining in the employ of Mr. Schaefer.

Max Arnheim & Co. have opened a new jewelry store at 976 Liberty St. Mr. Arnheim's engagement to his cousin, Miss Mamie Arnheim, is announced.

Keppler & Nieman, McKeesport, Pa., are improving their store, and have closed out

their East Liverpool store in order to give more attention to the one in the former place.

Buyers in Pittsburgh last week were: Frank Weylman, Kittanning, Pa.; John Zugschwert, Mansfield, Pa.; G. A. Shies, Irwin, Pa.; G. A. Boss, McKee's Rocks; E. A. Bloser, New Kensington; P. A. Ritter, Verona; and Fred Steckel, McKeesport.

FOR EASTER.

**BOOK MARKS**  
IN STERLING SILVER.

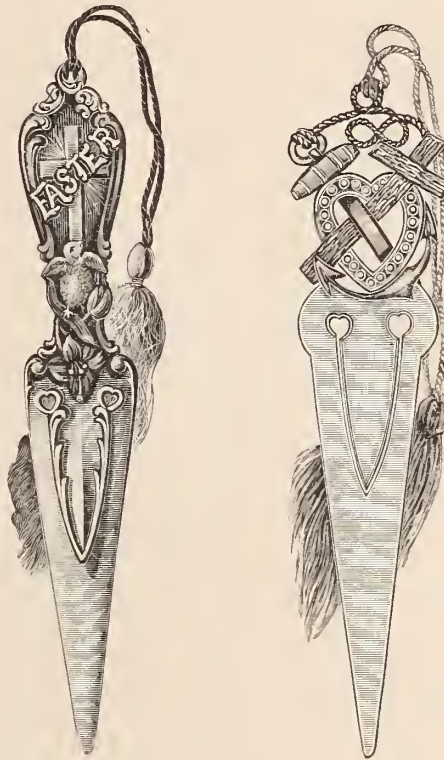

**ALVIN MFG. CO.,**  
... SILVERSMITHS ...

860 Broadway, - - New York.  
WORKS, IRVINGTON, N. J.

**Damascus**

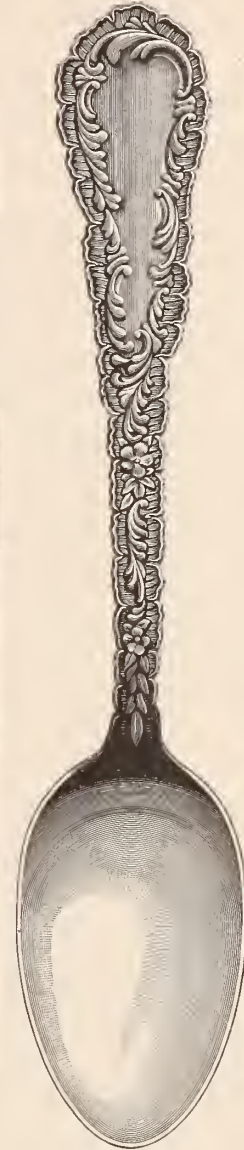

MADE IN  
A FULL LINE

The Best  
Pattern of the  
Season.

READY THIS  
SEASON.

A GENERAL  
LINE OF

**Hollow  
Ware.**

New  
Ideas Constantly.



DAMASCUS TEA.

**F. M. Whiting & Co.,**

MANUFACTURERS OF  
**STERLING SILVERWARE,**  
Novelties in Silver Jewelry.  
NORTH ATTLEBORO, - - MASS.

For **BADGES AND MEDALS**

Flag Pins, Class Pins, Class Rings  
and Special Work of all Descriptions  
SEND TO **E. R. STOCKWELL,** MANUF'R,  
19 John Street, New York

**R., L. & M. Friedlander,**



IMPORTERS OF  
**DIAMONDS.**

WHOLESALE  
**JEWELERS.**

JOBBERS IN  
**American Watches.**

Tools, Materials, and Optical Goods.

Send for Catalogue.

65 & 67 Nassau Street, New York.



## Our Traveling Representatives



Traveling representatives may consider these columns open for the publication of any news or items of interest regarding themselves or their confreres.

**J.** J. ROLESTON has started out over a portion of his old route for the Aikin-Lambert Jewelry Co., and will also represent the gold pen line manufactured by Aikin, Lambert & Co.

Charles Jeanneret left for the northwest Wednesday to show the trade a firm line of mountings and diamond mounted goods of the Juergens & Andersen Co. make.

M. F. Thornton, representing Aikin, Lambert & Co., has started out on the road to call on his old friends and customers, and is meeting with good success. A. S. Riley, also representing this firm, is now showing their samples, which include some new and original designs which are taking well with the trade and customers of the house.



JAS. A. CHENEY.

Jas. A. Cheney, well-known to the trade through his connection with several prominent firms, as Baldwin, Sexton & Peterson, Taylor & Bro., Williamson & Co., Henry E. Oppenheimer & Co. and others, has engaged with Ludwig Nissen & Co., 18 John St., New York, to cover the territory heretofore looked after by Alex. C. Chase, who has retired from the firm of Ludwig Nissen & Co., details of whose dissolution are given under the New York Notes.

For the new firm of McIntire, Ulmer & Co., Philadelphia, Pa., Harry C. Ulmer covers Pennsylvania and A. R. McIntire Philadelphia, Boston and Washington.

A. W. Pierce, who has been making an extensive trip through New York State and Pennsylvania in the interest of the Winsted Optical Co., arrived home Feb. 16.

Edward S. Robbins, formerly with the E. N. Welch Mfg. Co., has taken a position with the Bristol Brass & Clock Co. as traveling salesman, and will represent the German silver department. He succeeds H. B. Hall.

Traveling men visiting Davenport, Ia., jewelers the past week were: W. L. Supple, William B. Kerr & Co.; F. R. Horton, Carter, Sloan & Co.; Wm. Sisco, Ansonia Clock Co.; M. Gregory, Strobell & Crane.

O. A. Schneider, representing Hammel, Riglander & Co., New York, has returned to Chicago from a western trip. Mr. Blank, of the optical department of the firm, has

reached Chicago in his circuit of western trade.

Eastern jobbers and manufacturers represented in the Twin Cities the past week were: S. & B. Lederer, by G. Rodenburg; the Holmes & Edwards Silver Co., and Manhattan Silver Plate Co., by A. E. Hall; Keystone Watch Case Co., by H. M. Carle.

Active hustling in the western metropolis is represented in the persons of T. F. Fessenden, Fessenden & Co.; Richard Robinson, Richard Robinson & Co.; Jo. Berl, Dattelbaum & Friedmann, A. Peabody; Wm. Rosenberger, A. Wallach & Co.; D. J. Frankel and L. Engel, Joseph Frankel's Sons; Isadore Stern, Stern Bros. & Co.; E. P. Tiffany F. H. Sadler & Co.; B. B. Brady, B. B. Brady & Co.

Salesmen visiting Boston last week included: T. B. Wilcox, Pairpoint Mfg. Co.; Hipp. Didisheim, New York; M. E. Van Bergh, Rochester, N. Y.; George W. Hutchison, Hutchison & Heustis; E. A. Woodmancy, Potter & Buffinton; John Hagan, Hagan Bros.; E. L. Spencer; W. Melcher, Bennett, Melcher & Co.; Fred. S. Gilbert, North Attleboro; George Whiting, S. E. Fisher & Co.; H. B. Bacon, Lincoln, Bacon & Co.; Chris. Morgan, Rogers & Bro.

Traveling men in Pittsburgh, Pa., during the "cold snap" last week were: Ben. Eichberg, Eichberg & Co.; G. W. Hull, Silver Plate Cutlery Co.; H. Bloch, Matthews & Willard Mfg. Co.; G. Nelson Fenn, C. Sydney Smith; A. W. Wagner, Leon J. Glaenger & Co.; John W. Mason, Nacke, Brinkman & Co.; W. Kleinschmidt, John F. Saunders; W. G. Sherman, W. G. Sherman & Co.; Jean Holbrook, Frank W. Smith; C. A. Boynton, Wm. B. Kerr & Co.

The following traveling salesmen were in Kansas City, Mo., recently: Fred J. Foster, Unger Bros.; Monroe Engelsman, for Maurice Weil; Lawrence H. Smith, Bippart & Co.; Mr. Fife, the A. F. Towle & Son Co.; T. S. Walpuski, American Morocco Case Co.; H. A. Bliss, Kremetz & Co.; E. A. Moore, Geo. H. Fuller & Son; Sam H. Fink, Fink, Bodenheimer & Co.; Carl P. Hoffmann, J. J. Sommer & Co.; Mr. Crane, Strobell & Crane; Steve Smiths, Henry Williams & Co.; Geo. F. Heidet, C. F. Rumpf & Sons; Chas. F. Ketcham, Riker Bros.; De Lancey Stone, Shafer & Douglas; Geo. L. Abbott, J. Hoare & Co.; Henry Jacobson, Jacobson Bros.; Norbert Gunzburger.

Travelers noticed in Syracuse, N. Y., the past week were: Mr. Smith, Smith & Knapp; S. Glenn Walmsley, Tenner & Baum; Charles Van Ness, Reeves & Silcock; M. Gattle, Falkenau, Oppenheimer & Co.; Charles W. Hempel, Sandland, Capron & Co.; Frank H. Dana, G. E. Luther & Co.; C. P. Braitsch, W. J. Braitsch & Co.; Theo. M. Woodland, Larter, Elcox & Co.; Chas. S. Isabel, L. Strasburger's Son & Co.; Harry B. Kennin, H. D. Merritt & Co.; N. Coughlin, William Link; Herbert E. Slater, Champenois & Co.; E. Kubie, Imperial Optical Co.; C. Zugsmith, Albert Zugsmith; J.

L. Shepherd, Keystone Watch Case Co.; Chas. Kahn, Saloman Davidson; Mr. MacDonough, Courvoisier-Wilcox Mfg. Co.; E. I. Rogers, Parks Bros. & Rogers; C. Rosenbaum.

The following travelers visited Indianapolis last week: V. L. Burgesser, Kremetz & Co.; A. R. Varian, Dennison Mfg. Co.; Leon Block, L. D. Block & Co.; Mr. Fessenden, Fessenden & Co.; Mr. Abbey, E. Ira Richards & Co.; Mr. Potter; R. Wallace & Sons Mfg. Co.; Tom Davis, Middleton Plate Co.; Mr. Linton, F. M. Whiting & Co.; G. Blecker, Bassett Jewelry Co.; Mr. Bresslau, Stone Bros.; F. L. Pettee, Waterbury Clock Co.; Mr. Cutler B. F. Norris, Alister & Co.; Mr. Stransky, Ferd. Bing & Co.; H. C. Walton, Wadsworth Watch Case Co.; R. A. Thompson, for Henry Glorieux; F. W. Trewin, Keystone Watch Case Co.; Chas. Roe, E. Ingraham Co.; W. J. Miller, Seth Thomas Clock Co.; Jos. Becker, Jos. Fahys & Co.; Chas. Whiting, Crescent Watch Case Co.

Nelson J. Bartholomew, familiarly known as "Bart" among his fellow travelers, who left the employ of G. B. Barrett & Co., Pittsburgh, Pa., last June, and engaged in the dry-goods business in Dunkirk, N. Y., died Feb. 12, of typhoid fever. Mr. Bartholomew was well-known to the trade in New York, western Pennsylvania, Ohio, Indiana and Michigan, where he had many friends to whom this sad news will be a great shock. He had been many years with Joseph Nelson & Co., Dunkirk, and for the past two and a half years was connected with G. B. Barrett & Co., as traveler. Mr. Bartholomew was married only last July to a lady of Jackson, Mich. The most profound sympathy toward his bereaved wife is tendered by his host of friends in and out of the trade in Pittsburgh.

### DEATH OF TOM ANDERSON.

CHICAGO, Ill., Feb. 16.—Tom Anderson, the well known traveler for M. A. Mead & Co., passed away at the home of A. B. Bell, 3032 Calumet Ave., Feb. 8th, from dropsy of the heart. Mr. Anderson was born in 1840, in Birmingham, Eng. Some years ago he engaged in the jewelry and optical business in Toronto, Can., and later returned to England. Again crossing the ocean he secured a position as traveler for Otto Young & Co., whom he served six years, when he took a similar place with M. A. Mead & Co. He remained four years with this house, then two years with J. T. Scott & Co., and two years later returned to M. A. Mead & Co., with whom he remained two years, until his death.

Mr. Anderson was a conscientious and honest worker, a good man in every way. His sympathies were ever extended to those in need. "Honest Tom Anderson was a square and upright man," is the eulogy pronounced by his many friends, and enemies he had none. Mrs. Anderson died three years ago, and three grown-up sons and two daughters, the youngest a miss of 13 years, survive him.



## MATTERS IN JEWELRY STOREKEEPING.

That this department shall prove mutually beneficial to our readers, it is desirable that the members of the trade generally communicate with THE CIRCULAR regarding any advantageous device or plan they are utilizing in the conduction of their business.

### How Retail Jewelers Should Advertise.

"I DO not know any trade where so many golden opportunities can be secured in the advertising line as ours," says G. F. Heydt, advertising man for Tiffany & Co., in the *Advertisers' Review*, "and we are constantly on the lookout to make the most of them. It is surprising what can be done by a little well timed and adaptive advertising. By this I mean that the various society events and so on can be made lucrative to the jeweler if he goes about it in the right way.

"Take the New York Horse Show, for instance. During the Horse Show week we reached the people who go to it and are interested in it, both by the newspapers, the class papers and the catalogue or program of the event. For the last few years, during horse show times, I have advertised horsey souvenirs; that is, miniatures of favorite hunters, trotters, hackneys, etc. We also advertise horse-shoe, whip and horse-head scarf pins and charms of various kinds. This system applies to almost every show of this kind; the Masons' Fair and the football game and different things of that nature. Of course the advertising has to be worded to suit the occasion, and both the medium and language must be appropriate.

"Outside of specialties of this kind we do not advertise in the dailies any particular article of jewelry. What we do advertise though, during the Winter season, which is, of course, our best, is the Tiffany 'Blue Book,' which is our catalogue.

"We use the magazines a little, but we do not think that they are the best mediums for our use. Possibly it is because the returns from them are largely indirect; but, be that as it may, we are not any too strongly impressed with their value.

"I wish to say a word about the college papers. We like the college papers and use them very liberally, and we find that it pays. The young men who go to college come, as a rule, from wealthy families, and we want to familiarize our name and goods with them and get them in the habit of trading with us. This means a good deal, for once their trade and confidence is secured, we will have them, as a rule, for a lifetime. Besides this, we get immediate returns from the college papers, for we particularize in our college advertisements, the college pins, emblems, etc., besides which we make a good many of the various trophies; that is, cups and medals.

"Speaking of trophies, a very good 'ad' is secured out of each one of these, and we

often make one considerably below cost and charge the difference to our advertising account. You see, that when a cup is competed for, everybody interested in the competition, and there are usually many thousands, knows that Tiffany & Co. made up the cup, and, as we are always extremely particular about the designs and finish of these goods, they are generally admired and commented upon, and our good work is thus riveted in many minds.

"We exhibit these trophies always in our windows, where they are noticed by great crowds, and usually we contrive to have them exhibited in the place where they are competed for.

"Jewelry advertising is almost what you might call auxiliary advertising, but to get the first results the papers are the best mediums. After these the work must be followed up and every opportunity seized."

### A Plan to Obtain Watch Repairing.

WILSON BROS., Boston, Mass., have instituted a novel undertaking in insuring watches. Here's the idea: For \$2, paid annually, a watch, gentlemen's or ladies', is guaranteed against trouble. That is to say, \$2 will keep it in repair for one year, no matter how often it may get out of order or what may be the cause. It may be dropped on a brick sidewalk, or you may fall overboard with it in your pocket; no questions are asked and no limit put upon repairs to the movement up to a total of \$25 at the

rates usually charged. All styles of watches are included in the new offer except a few special movements. The plan should become popular.

It is a fact that not one man in a hundred remembers the number of his watch. The register secured by this guarantee is therefore a complete reference in case of loss or theft. A label bearing the register number is also inserted in the cases of the watch requesting any stranger, in case of personal accident or sudden illness, to telegraph this number to Wilson Bros., who agree to promptly notify family or friends.

### How to Obtain Missionaries.

DAVIDOW BROS., Scranton, Pa., some time ago held a contest which proved very successful. It was open to any person in Lackawanna county over 15 years of age. The firm offered three hundred dollars in prizes as follows: First prize, solid gold watch; second prize, a neat silver tea-set, gold lined; third prize, 14k. gold filled watch and chain; fourth prize, gold filled watch; fifth prize, handsome scarf pin; sixth prize, silver watch; seventh prize, fine marble clock; eighth prize, fine pair pearl opera glasses; ninth prize, quadruple silver plate castor; tenth prize, solid gold pen and holder. They were to be given to the person bringing in the greatest number of signatures of persons living in Lackawanna county. Signers were compelled to write Davidow Bros., 217 Lackawanna Ave., with their name and address plainly written. It will be seen that the contestants were really so many missionaries in the interest of the firm.

### HENRY ABBOTT,

MANUFACTURER OF

Stem-Winding Attachments  
FOR WATCHES,

No. 2 Maiden Lane, NEW YORK.

## THE WARREN EYE PROTECTOR.

(Patented Jan. 12, 1892, Feb. 21, 1893.)

SAVES THE EYES FROM Dust, Wind, or Glaring Light.

FOLDS, IN A COMPACT CASE, IS

COMFORTABLE, DURABLE, WATER AND DUST PROOF.

Its large field does not obstruct the sight. No brittle substance to endanger face under sudden blows. Oculists and Physicians recommend it.

Travelers, Cyclists, Railroadmen, Horsemen, Motormen, Quarrymen,

PRONOUNCE IT INDISPENSABLE FOR MAN OR WOMAN.

ASK YOUR DEALER FOR IT,

Colors, Clear, Smoke, Blue or Green. Black frames, 50c. Silver, 75c. Sent by mail on receipt of price. Manufactured solely by

The Nous Verrons Company, P. O. Box 3273,  
BOSTON, MASS



# CLASSIFIED INDEX TO ADVERTISEMENTS.

All Advertisements are entitled to one insertion under proper heading. Extra insertions, \$6.00 per annum. Extra Headings, \$12.00 per annum.

	Page.		Page.		Page.
<b>Art Pottery, Bric-a-brac, Etc.</b>		<b>Gold and Rolled Plate Jewelry.</b>		<b>Rubber Stamps and Type.</b>	
Ahrenfeldt, Charles & Son, 50-52-54 Murray St., N. Y. ....	38	Foster & Bailey, Providence, R. I. ....	3	Dietz, Wm. H., Chicago, Ill. ....	19
Bing, Ferdinand & Co., 106 Grand St., N. Y. ....	38	Read, M. L. & Co., Providence, R. I. ....	40	<b>Sample Trunks.</b>	
Borgfeldt, Geo. & Co., 18, 20 & 22 Washington Place, New York. ....	41	<b>Horological Schools.</b>		Crouch & Fitzgerald, 161 Broadway, N. Y. ....	43
Hinrichs & Co., 29 & 31 Park Place, N. Y. ....	43	American Horological Institute, Lancaster, Pa. ....	22	<b>Silver Mounted Ebony Goods.</b>	
Straus, L. & Sons, 42 to 48 Warren St., N. Y. ....	37	Chicago Watchmakers' Institute, Chicago, Ill. ....	20	Deitsch Bros., 7 E. 17th St., N. Y. ....	2
<b>Assayers &amp; Refiners.</b>		Elgin Horological School, Elgin, Ill. ....	22	<b>Silver Plated Ware.</b>	
Clark, J. L., Philadelphia, Pa. ....	43	Parson's School for Watchmakers, Peoria, Ill. ....	21	Pairpoint Mfg. Co., New Bedford, Mass. ....	5
Howard, S. P., 33 Maiden Lane, N. Y. ....	44	<b>Hotels.</b>		Rogers, Smith & Co., Meriden, Conn. ....	24
Le Long, L. & Bro., Newark, N. J. ....	44	Gibson House, Cincinnati, O. ....	20	<b>Sterling Silverware.</b>	
Rathbone, J., Providence, R. I. ....	37	<b>Jewelers' Findings.</b>		Alvin Mfg. Co., 860 Broadway, N. Y. ....	29
Schawel, J. & Co., 29 John St., N. Y. ....	44	Lind, Thos. W., Providence, R. I. ....	28	Bachrach & Freedman, 1 & 3 Union Sq., N. Y. ....	28
<b>Auctioneers.</b>		<b>Jewelry Mailing Boxes.</b>		Campbell-Metcalf Silver Co., Providence, R. I. ....	44
American Syndicate of Jewelry Auctioneers, New York and Washington. ....	2	Am. Railway Supply Co., 24 Park Place, N. Y. ....	40	Reed & Barton, 37 Union Square, N. Y. ....	19
French, J. H., P. O. Box 2775, N. Y. ....	5	<b>Jewelry, Silverware and Optical Cases.</b>		Shiebler, Geo. W., Co., 179 Broadway, N. Y. ....	4
Prince, J., 137 Broadway, N. Y. ....	44	Steinhaus, Theo. C., 10 Maiden Lane, N. Y. ....	33	Towle Mfg. Co., Newburyport, Mass. ....	43
Rich, H. M. & Co., Boston, Mass. ....	38	<b>Jobbers, Watches, Diamonds, Etc.</b>		Wallace, R. & Sons Mfg. Co., 3 Park Place, N. Y. ....	6
Scott, De B. O., 20 Murray St., N. Y. ....	43	Allen, Benj, Chicago, Ill. ....	20	Whiting, F. M., North Attleboro, Mass. ....	29
<b>Badges, Medals, Etc.</b>		Brethauer Watch and Jewelry Co., Chicago, Ill. ....	20	Wood & Hughes, 10 John St., N. Y. ....	43
Irons & Russell, Providence, R. I. ....	7	Cross & Beguelin, 17 Maiden Lane, N. Y. ....	2	<b>Spectacle and Eyeglass Cases.</b>	
Schlechter, G. A., Reading, Pa. ....	26	Conover, David F. & Co., Philadelphia, Pa. ....	8	Birmingham, Wm. & Co., 728 Arch St., Phila. ....	44
Stockwell, E. R., 19 John St. N. Y. ....	29	Freund, Max & Co., 8 Maiden Lane, N. Y. ....	34	White, W. B. & Son, Boston, Mass. ....	33
Willson, Chas. G., Reading, Pa. ....	42	Friedlander, R., L. & M., 65, 67 Nassau St., N. Y. ....	29	<b>Stem Winding Attachments.</b>	
<b>Clocks, French, English and American.</b>		E. A. Giles, Receiver, Chicago, Ill. ....	21	Abbott, Henry, 2 Maiden Lane, N. Y. ....	31
Jacques, Chas., Clock Co., 22 Cortlandt St., N. Y. ....	44	Myers, S. F. & Co., 48 Maiden Lane, N. Y. ....	44	<b>Thimbles.</b>	
<b>Cut Glass.</b>		Oppenheimer Bros. & Veith, 35 Maiden Lane, N. Y. ....	17	Ketcham & McDougal, 198 Broadway, N. Y. ....	7
Mt. Washington Glass Co., New Bedford, Mass. ....	40	<b>Leather and Silver Goods.</b>		<b>Tortoise Shell Goods.</b>	
<b>Diamond &amp; Precious Stone Importers.</b>		Deitsch Bros., 7 E. 17th St., N. Y. ....	2	Rice & Hochster, 483-485 Broadway, N. Y. ....	23
Disselkoen, John N., 19 E. 16th St., N. Y. ....	27	<b>Musical Boxes.</b>		Potter, W. K., Providence, R. I. ....	43
Eichenberg, Julius, Providence, R. I. ....	26	Jacot & Son, 298 Broadway, N. Y. ....	2	<b>Tool Manufacturers and Dealers.</b>	
Falkenau, Oppenheimer & Co., 40 Maiden Lane, N. Y. ....	44	<b>Optical Goods.</b>		American Watch Tool Co., Waltham, Mass. ....	10
Fera, Henry, 10 Maiden Lane, N. Y. ....	40	Berger, Albert & Co., 47 Maiden Lane, N. Y. ....	38	Bullock, O. W. & Co., Springfield, Mass. ....	4
Hedges, Wm. S. & Co., 170 Broadway, N. Y. ....	26	Geneva Optical Co., Chicago, Ill. ....	19	Gesswein, F. W., 39 John St., N. Y. ....	38
Kipling, R. A., Hays Bldg., N. Y. ....	26	Globe Optical Co., Boston, Mass. ....	10	Hardinge Bros., Chicago, Ill. ....	20
Kipling, E. E., 182 Broadway, N. Y. ....	44	Kirstein's, H. E., Sons Co., Rochester, N. Y. ....	43	Logan, A. J., Waltham, Mass. ....	5
Lorsch, Albert & Co., 37 Maiden Lane, N. Y. ....	44	Queen & Co., Philadelphia, Pa. ....	9	Moseley & Co., Elgin, Ill. ....	20
Randel, Baremore & Billings, 29 Maiden Lane	27	Scheidig, John, 43 Maiden Lane, N. Y. ....	4	Oliver, W. W., Buffalo, N. Y. ....	22
Rothschild, M. D., 41 & 43 Maiden Lane, N. Y. ....	44	Spencer Optical Co., 15 Maiden Lane, N. Y. ....	34	<b>Trunks and Traveling Bags.</b>	
Smith, Alfred H. & Co., 182 Broadway, N. Y. ....	26	The Nous Verrons Co., Boston, Mass. ....	31	Crouch & Fitzgerald, 161 Broadway, N. Y. ....	43
Tannenbaum, L., & Co., cor. Maiden Lane and Nassau St., N. Y. ....	15	<b>Optical Schools.</b>		<b>Watch Manufacturers.</b>	
<b>Diamond Jewelry.</b>		The Chicago Ophthalmic College, Chicago, Ill. ....	19	Charmilles Watch, N. Y. ....	12
Jeane, Paul, Bradley Bldg., N. Y. ....	34	<b>Office Building.</b>		<b>Watch Case Manufacturers.</b>	
Leonhardt & Curran, 44½ Maiden Lane, N. Y. ....	40	Cruikshank, E. A. & Co., 176 Broadway, N. Y. ....	28	The Planchamp & Becker Co., Chicago, Ill. ....	23
<b>Engraving Machines.</b>		Diamond Exchange Building, 14 Maiden Lane. ....	16	<b>Watch Dials</b>	
A. E. Francis, Cleveland, Ohio ....	44	<b>Paneled Metal.</b>		O'Hara Waltham Dial Co., Waltham, Mass. ....	44
<b>Fine Stationery.</b>		Northrop & Co., Pittsburgh, Pa. ....	35	<b>Watchman's Clocks.</b>	
Parsons & Greene Co., 18 Murray St., N. Y. ....	5	<b>Pens, Pencil Cases, Etc.</b>		Hausburg, O. E., 41 Maiden Lane, N. Y. ....	42
<b>Gold and Silver Plating Works.</b>		The Boston Pen Co., Boston, Mass. ....	4	<b>Watch Importers.</b>	
Bolstad Mfg. & Plating Co., Chicago, Ill. ....	21	<b>Patents.</b>		Hyde's, J. E., Sons, 22 Maiden Lane, N. Y. ....	37
Brunor, Emil, 93, 95, 97, William St., N. Y. ....	37	Belt, C. T., Washington, D. C. ....	28	<b>Watch Keys.</b>	
<b>Gold Jewelry.</b>		<b>Platinum Importers.</b>		Clark, A. N., Plainville, Conn. ....	2
Carter, Sloan & Co., 15 Maiden Lane, N. Y. ....	27	Schawel, J. & Co., 29 John St., N. Y. ....	44	<b>Watch Repairers.</b>	
Johnson, R. M., 67 Washington St., Chicago, Ill. ....	21	<b>Ring Gauges.</b>		Muller, Hugo, Chicago, Ill. ....	21
Krementsz & Co., 182 Broadway, N. Y. ....	2	Engle, A. W., Chicago, Ill. ....	21	Henry, Peter, Cincinnati, O. ....	29
Larter, Elcox & Co., 21 & 23 Maiden Lane, N. Y. ....	7	<b>Ring Makers.</b>			
Pfeil, Chas. H., Chicago, Ill. ....	21	Bryant, M. B. & Co., 10 Maiden Lane, N. Y. ....	25		
Reddall, John W., Newark, N. J. ....	11	Bowden, J. B. & Co., 192 Broadway, N. Y. ....	7		
Street, Geo. O. & Sons, 15 John St., N. Y. ....	2	Hildreth Mfg. Co., 51 Maiden Lane, N. Y. ....	42		
Street, Geo. O. & Sons, 15 John St., N. Y. ....	11				
Schwartz, W. H., & Co., Newark, N. J. ....	28				
Unger Bros., 192 Broadway, N. Y. ....	25				
Webster, G. A., Chicago, Ill. ....	21				



## Special Notices.

Rates 75c. per insertion for notices not exceeding 3 lines (25 words), additional words 2 cents each. If answers are to be forwarded, postage stamps must be enclosed. Two insertions, 15 per cent. off; three insertions, 20 per cent. off; four insertions or more, 25 per cent. off. Payable strictly in advance. Display cards on this page will be charged at \$2.00 per inch for first insertion, subject to same discount as above for subsequent insertions.

Under the heading of **Situations Wanted** on this page advertisements will be inserted for **One Cent a Word**. This offer refers to **Situations Wanted only**. Payable strictly in advance. If answers are to be forwarded, postage must be enclosed.

## Situations Wanted.

Notices under this heading **ONLY** are charged at one cent a word, payable strictly in advance. If answer are to be forwarded, postage must be enclosed.

A JEWELER wants position with a wholesale or retail store, to take charge of shop, making and repairing. Address Metallurgist, care JEWELERS' CIRCULAR.

WANTED, a position in factory or as traveling salesman by a gentleman of 25 years' experience in the plain gold ring business. Address "H," care of JEWELERS' CIRCULAR.

SITUATION WANTED by watchmaker and jeweler; young man; three years' experience; best of references. Address W. A. Babcock, Walnut, Ill.

WANTED, SITUATION—Manager of a business for two years past. Do all branches of work—watchmaking, engraving, seal making, jobbing, selling, buying. Box 695, What Cheer, Ia.

POSITION wanted by young man as assistant entry clerk. Unquestionable references. Address "W. C.," care JEWELERS' CIRCULAR.

SITUATION WANTED by watchmaker who thoroughly understands his business. Competent on chronographs and French clocks. Does all kinds of jewelry repairing. Good salesman. Address "Energetic," care JEWELERS' CIRCULAR.

SALESMAN.—Young man 23 years, wants position; acquainted with wholesale and retail jewelry trade; salary moderate. A. L. H., care JEWELERS' CIRCULAR.

WATCHMAKER, who has had 13 years' experience at bench, wants a steady situation. Can do any kind of repairing and jobbing, or will take charge of jewelry stock. Can give A1 references. Address Lock Box 756, Eureka Springs, Ark.

GOOD ENGRAVER, age 25, can repair clocks and watches. Will send sample of engraving. Best of references. Address D. T., care JEWELERS' CIRCULAR.

SITUATION wanted by first-class watchmaker, jewelry repairer, clerk and do common engraving; young man and married; have bench and tools. Address 315 Day St., Decorah, Iowa.

WANTED—Position as salesman or jeweler and watchmaker; 15 years' experience; can furnish the best of references. Address V., JEWELERS' CIRCULAR.

WANTED—Position by first-class watchmaker; had 20 years' experience on all kinds of watches, clocks, chronographs and chronometers; speaks French and a little English. Address S. Joseph, 17 Rector St., New York City.

SITUATION wanted by young man 21; is a good clockmaker, and would like to finish his trade as watchmaker. Address A. Guenter, 875 Sixth Ave., City.

SITUATION wanted in jobbing house or with manufacturer by a young man 20 years of age. Has had four years' business experience and can furnish highest references. Address Honest Effort, care JEWELERS' CIRCULAR.

## Help Wanted.

WANTED—A first class workman who can make and repair fine jewelry and who thoroughly understands electro-coloring. Address Bell Bros. Co., Ogdensburg, N. Y.

TRAVELING SALESMAN wanted, visiting the retail jewelry trade to carry side line on commission; samples small, attractive and great sellers. Address "Syntax," JEWELERS' CIRCULAR.

## To Let.

BROADWAY STORE, near Post Office. Half store and one window. Lease. 2 Astor House, New York.

TO LET.—A large office, 20 x 40, first floor, No. 11 Maiden Lane. \$60 a month

TO LET AT LOW RENT—Two very desirable offices, one and two flights up, in building, No. 12 Maiden Lane. For particulars apply to Lissauer & Co., 12 Maiden Lane, N. Y.

## Miscellaneous.

I BUY JEWELRY STOCKS—Manufacturers, jobbers and retailers desiring to dispose of surplus or entire stocks of diamonds, watches and jewelry can find quick cash buyer by addressing Stephen S. Harmon, 134 East 96th St., New York City.

## DEMAGNETIZING.

PERFECT WORK—Watch repairing in all its branches; all work warranted. Winslow & Penney, 608 Masonic Temple, Chicago.

FOURTEEN karat gold solder that will flow on eight karat work; makes a hard solder job a pleasure. With this solder there is no danger of melting low karat specs. No white joints on rings. It is just what you want. Sample by mail 25 cents. F. W. Hall, Sterling Silver Novelties, Columbus Memorial Building, Chicago, Ill.

SEND for new 1894 prospectus of Trowbridge's Engraving School. Lowest terms of any school. Board \$12 to \$15 per month. Winona, Minn.

ENGRAVING MACHINE, also optometer for watches, or anything I can use. Address W. A. Sherwood, care JEWELERS' CIRCULAR.

WANTED—A partner having \$4,000 or \$5,000 to buy a half interest in a good paying jewelry business in New York State. Practical man preferred. Address Brown, care JEWELERS' CIRCULAR.

WANTED PARTNER—A practical jeweler, who has \$2,000 in cash, can buy a half interest in a well established and good paying business, in one of the brightest manufacturing cities in the United States. Address "Partner," care CIRCULAR.

MANUFACTURERS selling the jobbing trade can make very advantageous arrangements with experienced salesmen to represent their goods in New York City and cover jobbing trade throughout the United States. Address "Copious," JEWELERS' CIRCULAR.

\$300 WILL BUY watch, clock and jewelry repairing business, with safe, engraving machine, lathe and small tools and material, also work on hand; town of 3,500 inhabitants; no opposition. Address T. Courtney, Westport, Conn.

## For Sale.

FOR SALE.—A first class polishing lathe; all in good repair, at a low price for cash. Address G. W. Brown, 113 Point St., Providence, R. I.

FOR SALE.—Whitcomb 1 1/2 lathe, hand, with attachments. In perfect condition. Sold for want of use. Cash, at half price. For list of tools and particulars, address Wm. Gibbs, Helena, Mont.

FOR SALE.—Marvin book safe, nearly new, for sale cheap. Outside doors swing around to side, for use under high desk. Inside doors have lock. Can be seen at 19 Maiden Lane, on application to S. B. Mann or Cephas Brainerd, assignee of Chas. S. Crossman & Co., 47 Cedar St., New York.

FOR SALE—Two good jewelry stores, 30 and 20 miles from New York. One established 35 years, only one in 10 miles; carry a decent stock; village of 4,000. Will reduce stock or discount valuation. Address Bonanza, care JEWELERS' CIRCULAR.

FOR SALE—Jewelry store in New York City; must sell on account of other business at once. \$3,500. For particulars address "Beyer," care JEWELERS' CIRCULAR.

## FOR SALE

## IN CHICAGO.

An old established Retail Jewelry Business, on a very prominent corner in the business portion of the city. Fine Fixtures and a Clean Stock. A big bargain may be obtained, as owner wishes to retire.

Address C. B. S., care JEWELERS' CIRCULAR.

## FACTORY AND OFFICE TO RENT FROM MAY 1ST.

Desirable office on first floor with factory on fourth floor. John St., between Broadway and Nassau St. Office, 25x40; factory 25x75. Both connected by elevator and speaking tube. Factory well lighted and ventilated by four high sky-lights. Steam power according to wants. Rent \$2,000, or factory alone \$1,000. Address A. B. care JEWELERS' CIRCULAR.

## TO LET.

One of the most desirable Offices

— IN THE —

## HAYS BUILDING, 21 and 23 MAIDEN LANE.

APPLY AT OFFICE OF THE BUILDING.

WHITE'S EYE SHADE. **W. B. WHITE & SON**

MANUFACTURERS OF



Spectacle and Eye Glass CASES

90 SOUTH STREET, BOSTON.

Special Cases made to order for Optical Trade. Cases for Trial Lenses. Opera Glasses recovered, etc. Chatelaine Spectacle Cases, Metal Bound Leather Cases for combs, scissors, etc. Over forty kinds of cases manufactured.

## THEODORE C. STEINHAUS,

— MANUFACTURER OF —

## Fine Cases and Trays

For JEWELRY, SILVERWARE, &c.  
SAMPLE CASES AND TRAYS FOR TRAVELERS.  
Fancy Hard Wood Chests for Silverware, &c.

Linings, Cushions, Mounting, etc., for Silver Novelties.

10 MAIDEN LANE, NEW YORK.

## LEGENDS OF GEMS.

BY FRANK SHELLEY.

Gilt edged; bound in leather; a perfect specimen of the printer's and binder's art. Should be in every jeweler's library. Price, \$1.00. For sale by

THE JEWELER'S CIRCULAR PUB CO.



### News Gleanings.

Britt, Ia., is said to be in need of a jewelry store.

J. D. Hadermann has opened a new store in Leipsic, O.

H. Cassell has opened his jewelry store in Lockhaven, Pa.

L. C. Moore will engage in the jewelry business in Rockport, Mo.

The store of John F. Heingle, Rockport, Ind., was damaged by fire last week.

Henry Seeman has purchased the business of Saul Bros., Charter Oak, Ia.

Fred. A. Howe, Jr., has succeeded to the business of his father in Huntsville, Ala.

A. S. Mandeville, Athens, Ga., has moved his stock to another location in that town.

Gilbert Howe, jeweler, who had been a resident of Madrid, N. Y., many years, died a few days ago.

The stock and fixtures of A. Jankau, Cleveland, O., who recently assigned, are advertised for sale.

Mr. and Mrs. F. D. Day, Duluth, Minn. will start for the Pacific coast this week, to be gone about a month.

H. F. Graves, Parish, N. Y., is selling his stock at auction. Col. St. Clair Fechner, of Washington, D. C., is the auctioneer.

The jewelry business formerly conducted by Geo. E. Camm, Johnstown, N. Y., will be conducted in the future by Merrill J. Mann.

John F. Kohler, Richmond, Va., has released a deed of trust for \$7,155 on 20 feet of property on the south side of Broad St., between 2d and 3d Sts.

A pile of paper caught fire in the rear of Adolf Walter & Son's jewelry store, 52 Newark Ave., Jersey City, N. J., a few evenings ago; damage slight.

T. W. Gurley, for several years past engaged with D. J. Betz, jeweler, Frostburg, Md., has gone into the same business on his own account at Meyersdale, Pa.

In a fire in Collierville, Tenn., T. J. Firth lost 50 watches which had been placed in the store of T. H. Humphrey & Co., where the fire originated, for safe keeping.

P. A. Blakey, trustee of H. Stricher's stock of jewelry, Rusk, Tex., has sold out

the remainder of this stock at public sale to Linerd, Crow & Co., of New Orleans, La.

Geo. F. Merry, for 10 years with the Julius King Optical Co., Cleveland, O., has taken charge of the optical department of Anderton, Eberhardt & Co., Dayton, O.

A. Gipperich, for 40 years with the old firm of Mitchell & Tyler, and their successors, John H. Tyler & Co., Richmond, Va., has opened a store at 810 E. Main St., that city.

Cameron & Winterhalter, Butte City, Mon., have been dissolved, Mr. Cameron retiring from the business and Herman Towle, late of Hight & Fairfield, succeeding him.

The costly show case which contained the exhibit of the Manhattan Silver Plate Co. at the World's Fair is reported lost in transit from Chicago to the California Mid-Winter Fair.

D. H. Clawson, Watkins, N. Y., has invented a cyclometer with clock attachment, which registers the distance traveled by a bicycle rider, and also the exact time consumed in covering any number of miles.

The Harrison Jewelry Co., of Roanoke, Va., have incorporated to deal in jewelry with a capital stock of \$5,000 in single shares of \$10. The incorporators are: H. Adler, S. Kaplan and M. Harrison, of Roanoke.

The quantity of diamonds given to A. T. Hagen by the J. R. White Jewelry Co., Rochester, N. Y., as security for the payment of a note of \$1,500 was sold last week by order of the court. Mr. Hagen purchased them for \$1,425.

Three bloodhounds were taken to Clarence, Mo., last week to investigate the robbery of E. L. Cooper's jewelry store. The dogs went straight from the store to the residence of three men in the town, one of whom fell in a fit when he saw the dogs approaching. The parties suspected by the dogs were arrested.

A man who gave his name as Frank Lorenz, a jeweler and saloonkeeper of Milwaukee, Wis., went to South Bethlehem, Pa., a few days ago to meet a green goods man. He had become suspicious on the train and concluded not to go to the Pacific House, where he was to meet the swindlers. He next day left for the west.

The item published in the issue of Feb. 7 under this department (M. Berkele, of Maier & Berkele, Atlanta, Ga., has given real estate deeds aggregating \$1,400) we learn was erroneous. Maier & Berkele, neither as individuals nor as a firm, have ever executed a mortgage nor transfer. The initial of Mr. Berkele's given name is J. not M. This correction is justly due this reputable house.

Achory C. Smith, who was in the employ of G. Judd Williams, Urbana, O., for the past four years, has accepted a position with the well-known firm of Bennett & Guyselman, of the same city. We congratulate Mr. Smith on connecting himself with this firm, as they are wide-awake, progressive jewelers. Mr. Smith has been connected with the jewelry business in Urbana for the past 23 years, having learned his trade with P. R. Bennett, Jr., the senior member of Bennett & Guyselman.

### Lancaster, Pa.

At the annual meeting of the Hamilton Watch Co. on Tuesday afternoon last, the following directors were elected: Charles D. Rood, Captain; George M. Franklin, P. T. Watt, John F. Brimmer, Chas. A. Fon Der-smith.

Among the traveling men in town the past week were Herbert E. Slater, Champe-nois & Co.; H. D. Simpson, Reeves & Sil-locks; Morris Gugenheim, Marx, Veit & Co.; J. W. F. Ehlers; C. M. Cassal, Spencer Optical Mfg. Co.; M. Hall, Wilcox Silver Plate Co.; J. Jacoby, Louis Kaufman & Co.; J. Frank, Herzog, Goldsmith & Frank; Arthur Bradshaw, Meriden Britannia Co.; Jos. Van Veen, Bradley & Hubbard Mfg. Co.; M. F. Thornton, Aikin, Lambert & Co.

A statement in a local contemporary that the Hamilton Watch Co. were reducing their force owing to dull times is calculated to do that industry harm. A number of hands in the machinery department were dispensed with on Saturday last, but that was due to the fact that the work in that department, which was in operation a full year before the other departments were started, had been brought up to date. The other departments are constantly being enlarged and new hands added, and the outlook for business is of an encouraging character.

**Paul Jeanne,** EIGHTEENTH STREET and 4<sup>TH</sup> AVE., N. Y.  
(Bradley Building.)  
MANUFACTURER OF

≡ FINE ⊗ DIAMOND ⊗ JEWELRY. ≡

A Full Line  
OF ALL  
AMERICAN  
WATCHES.

**MAX FREUND & CO.,**  
Importers of Diamonds and Precious Stones,  
AMSTERDAM: 8 MAIDEN LANE,  
TULPSTRAAT 9. NEW YORK.

SPECIALTY:  
DIAMOND  
JEWELRY  
of our own design.

**THREE GREAT SUCCESSSES.**  
Our Industrial School of Optics Practical  
Our Swell Gold Construction Progressive  
Our Prescription Department Punctual  
**ASSURED SUCCESS TO YOU**  
If you take the Practical course in refraction,  
sell only The Progressive Swell End Eyewire Gold  
Spectacles and Eye Glasses, and send your special  
Prescription work to our special department which  
you will find accurate and punctual.  
Teaching by Kindergarten Demonstration and  
mechanical devices. The Spencer Patent Swell End  
Eyewire on Gold is the Perfection of construction.  
Our facilities for handling the great volume of  
special work are unexcelled. Avoid delay and  
errors by keeping in mind the old reliable  
**SPENCER OPTICAL M'FG CO.,**  
15 MAIDEN LANE, NEW YORK.



### Boston.

W. J. Knowlton has removed to 171 Tremont St. corner of Mason St.

P. Merrick Harwood and wife are on a two months' outing, having gone to California, and will visit the exposition during their stay on the Pacific coast.

President Geo. A. Carpenter, of the Bay State Watch Case Co., will retain his office on Washington St., in his new capacity as New England representative of the consolidated Crescent and Bay State companies.

Prompt action by one of the clerks saved the store occupied by Harwood Bros. and Chas. May, from a blaze Thursday. As it was, an accident to the electric light wire over Mr. May's counter caused some vivid flashes of lightning to play about the heads of clerks and customers until the current was cut off.

C. M. McFarland, Worcester, who has just moved into a handsome new store in that city, was among the buyers here last week. Others in town were: H. F. Burgess, Fairfield, Me.; John A. Williams, Canton; H. A. Stone, Ayer; Walter B. Studley, Rockland; F. B. Pearson, Nashua, N. H.; Hon. H. P. Dole, Lawrence.

The wholesale optical business of John W. Sanborn & Co., 414 Washington St., has been purchased by an incorporated company to be known as the Globe Optical Co. which will continue the business at the same address. A. G. Barber, who had charge of the business of the old concern, has been elected manager of the new corporation.

### The Attleboros.

The wife of M. A. Wheaton, of Wheaton & Smith, died Thursday.

Christopher C. Duckworth has been elected an honorary member of the Patria Club, of Pawtucket.

John Day and James Callahan, charged with stealing from Thos. Totten & Co., pleaded guilty and through the intercession of their employers, were released on payment of costs.

James M. Copeland, maker of novelties, and F. M. Whiting & Co., were Saturday morning the losers by fire to the extent of \$3,500. The blaze was seen about 2 o'clock. The thermometer was five degrees below zero and the firemen had a serious time to prevent a spread of the fire. The wooden addition was completely gutted, and Mr. Copeland's stock and machinery destroyed. His loss is about \$1,000. Several firms occupying the adjoining part of the Whiting building suffered slight losses on account of heat and water.

### Springfield, Mass

Arthur W. Adams has given up his position in C. A. Whitman's jewelry store, in Adams and will leave town.

The number of traveling men who have stopped over here recently is increasing. Among them were: George W. Smith, Car-

ter, Sloan & Co.; W. S. Campbell, Day & Clark; Vincent W. Henderson, Enos Richardson & Co.; Mr. McCarter, Gorham Mfg. Co.; H. C. Schwartz, Kremetz & Co.; L. Z. Call, Simpson, Hall, Miller & Co.; Albert Oppenheimer, R., L. & M. Friedlander.

William F. Cummings, who was arrested in Boston, and who was supposed to be the man who walked off with the trunk of H. C. Barnum, traveler for Shafer & Douglas, has been released, the police having convinced themselves that he was in Boston on the evening preceeding the robbery, as well as that morning. The other suspects, Andrew, alias Ahgreen and Virtue, alias Boyd, are still held, but the police will have difficulty in convicting them, as neither one answers in the least degree the reported description of the thief.

### Baltimore.

Mrs. Wm. Blum, who since her husband's death four years ago, conducted the jewelry store, 730 W. Baltimore St., died on Feb. 4th after a lingering illness. She left no children.

A. Jacoby & Co., silversmiths, 217 N. Calvert St., who recently made extensive improvements in their factory and sales-room, are now employing 30 skilled workmen to manufacture goods for their exclusively retail trade. They are giving particular attention to the designing and making of special pieces.

Freid & Crockin, manufacturers of finger rings, 207 E. Fayette St., have taken into partnership with them Samuel Cooper, the firm name being now Cooper, Freid & Crockin. By the addition of new capital and a skillful workman, they have noticeably increased their facilities. In the future they will make a specialty of new designs in initial and emblem rings.

### Canada and the Provinces.

The store of Wm. Kinehan, Bedford, Que., was burnt out last week.

The Philadelphia Optical Co., Toronto, suffered a slight loss by fire a few days ago.

Chas. P. Morgan, manufacturing jeweler, Truro, N. S., has assigned to S. D. McLellan.

The stock of W. H. Wood, Prescott, Ont., is advertised to be sold at auction on the 26th inst.

J. A. C. Julian, Montreal, is offering to compromise with his creditors at 75 cents on the dollar.

Michael Bros., Toronto, who were for many years at 47 King St. East, have removed their business to more commodious premises at 218 Yonge St., corner of Albert St.

The liquidator of the Acme Silver Co., Toronto, has presented a statement to the creditors showing that the profits of the company under his direction since last May were \$8,200.

Three boys, Frank Swarts, John Emigh,

alias Forbes, and James Morgan, who were arrested in Windsor, Ont., charged with burglariously breaking into the store of Wm. Pott, jeweler, have been brought to the jail at Woodstock. They have been remanded.

Mrs. Giles, the wife of a Toronto jeweler, has been figuring prominently in the courts lately and last week the jury brought in a verdict against her with damages of \$4,000 in favor of a Mrs. Chute, who claimed that the defendant alienated the affections of her husband. Of the amount of damages awarded \$2,500 was for alienation of affections and \$1,500 for being deprived of means of support.

There are two warrants out for the arrest of W. H. Gross, jeweler, 1162 Queen St. W., Toronto. He is not to be found and his creditors are looking anxiously for him. He rented the store at the above address and got some furniture on credit, which it is alleged he at once proceeded to dispose of. His creditors got wind of this proceeding and steps were taken to secure a warrant for his arrest. By the time this was done, however, he was out of the city.

### Newark.

Mrs. Wallace, wife of Frank Wallace, a well-known jeweler, died at the City Hospital last week.

Jacob Weber, a journeyman jeweler, committed suicide at his home, 269 Halsey St., on Wednesday last.

E. D. Bradley, formerly of Susquehanna, Pa., has started a jewelry store in the Allen block, Forest City, Pa. Mr. Bradley is a graduate of the Palmer & Swain Horological School, Waltham, Mass.

## PATENT paneled METAL CEILINGS Stamped Raised Panels.

ARTISTIC AND PERMANENT.

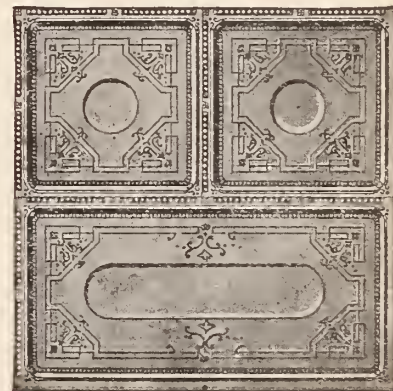

Easily applied in new buildings, and over old broken plaster or wood Ceilings. If interested in building or repairing, send stamp for Illustrated Catalogue, and state if CHURCH, HALL, STORE, OFFICE, or SCHOOL Ceiling is wanted. Address

A. NORTHROP & CO., Pittsburg, Pa.



### Lever Escapement With Indirect Impulse.

READERS of European (and THE CIRCULAR is afraid, also a few American) technical journals have doubtless come to the conclusion, when reading and studying the patents described in them, that people spend untold sums of money for patenting "inventions," "improvements," etc., which

been finally thought worthy of being patented.

The barefaced manner in which many of the most trifling alterations of a pin for a screw, or *vice versa*, are called *perfectionnements* would excite the risibility of an anchorite. Not long ago an inventor placed upon the plate a half-round bent strip of brass around the balance, called it *perfectionnement* and obtained a patent for it.

In the advertisements of this "epoch-making" invention (as the Germans call it) he demonstrates to his fellow mortal watchmakers that this ingenious conception prevents the breaking of the balance staff, should the watch ever be uncased by an unskilful watchmaker or layman. But why continue the long list of human vagaries?

These random remarks were caused by the "invention" to be described and illustrated in the following; it eminently belongs to the kind of patents of the half-round brass strip around the balance, just mentioned; still, since it concerns a new escapement, it arrests the attention of THE CIRCULAR. To call it new, however, is doing it too much honor, because various parts of it have existed heretofore.

Many of the watchmakers, readers of THE CIRCULAR, especially those who followed the calling in Europe, will at some time or other have seen the remarkable old watches that have upon the balance staff a small pinion which depths into a rack and conducts it to and fro at each balance vibration. At the opposite end of the rack is a small pendulum visible through a hole in the dial, and which generally beats half or full seconds. It is self-evident that this mechanism can be considered only as a plaything, since the fairly large friction of the pinion levers and rack teeth are as disadvantageous as possible for the regularity of rate. Nevertheless, this construction has been resuscitated and adapted to the lever escapement. The inventor, a watchmaker in Courgenay, Canton Berne, says in his application for a patent, that "the escapement constructed by him possesses the advantage that it can be adjusted more readily because each balance vibration requires one second; and watches with this kind of escapement, otherwise being equal in all respects with the common kinds of watches, will go longer than the ordinary kinds, the balances of which vibrate one-fifth second."

Accompanying illustrations will make the "new escapement" more readily understood. Fig. 1 is the enlarged plan, Fig. 2 a side view in cross section on the line X X in Fig. 1; on account of plainness, the illustration of Fig. 2 gives the whole movement as being much higher than it really is. The

actual escapement is that of an ordinary lever with the escape wheel A and the lever B. The former has the club teeth of Swiss shape, and operates in the usual manner upon the pallets *o o* of the lever B.

The fork C differs from the usual style in so far that it has two very long prongs, *bb*, Figs. 1 and 2. The fork C, now, does not stand in direct connection with the balance, but in order to produce the slow vibration of the balance, it is connected indirectly with the latter by means of the peculiar wheel, with tooth rim inside, H, Fig. 1 This wheel has only one cross bar *d*, and revolves around its staff *e*. Opposite the cross bar *d* the wheel H has at a somewhat projecting place *g*, of the wheel rim a pin *f*, Figs. 1 and 2, which in the present watch takes the place of the impulse pin, and enters in the same way into the fork notch C (Fig. 1).

The connection of the wheel H with the balance E, is established by three pins *nn*, Fig. 1, which are located on a disc *m*, Fig. 2, upon the balance staff D, and seize into the inner tooth rim of the wheel H. The latter therefore, takes the place of the rack in the old watches spoken of above, while the three pins, so to say, represent a hollow pinion depthing into this rack.

Fig. 2 shows how the escape wheel A is retained by the bridge *j*, the wheel H by the cock *c*, and the balance staff D by the balance bridge F, upon the plate G. The performance of this escapement is as follows: The escape wheel A operates upon the lever B and imparts to it its ordinary to and fro motion. By the fork notch C the impulse exerted by the escape wheel upon the lever is transported upon the pin *f* or the wheel H, and by the tooth rim of this latter again upon the pins *nn*, or upon the balance staff D. A glance at Fig. 1 shows that by the ordinary lever motion of 10°, the impulse angle of the balance (the impulse being imparted very nearly to the axis), amounts to at least 30° toward each side from the center line. The balance makes, therefore, two or three full revolutions at each vibration.

The balance spring is constructed in such a manner that each single vibration lasts precisely one second. The manufacturer has therefore the choice of either reducing the train by leaving out one wheel, so that in spite of the long duration of the vibration, the watch will go only 24 hours or else by retaining all the wheels to produce a watch with a five days' rate after one winding. In either case, the dial can be supplied with an independent seconds hand.

These two advantages: the independent seconds hand and the longer rate, THE CIRCULAR is prepared to acknowledge as such. But the various disadvantages: a much more complicated escapement weighted down with an infinite amount of friction, it leaves to the sound judgment of its readers. Its "private opinion publicly expressed," is that the sole impelling idea of the inventor was to produce something, no matter what, and that he succeeded in doing it.

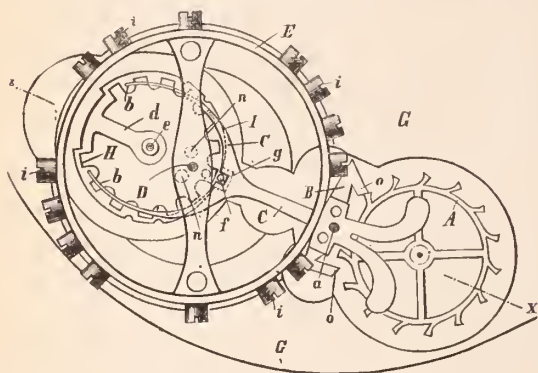

FIG. 1.

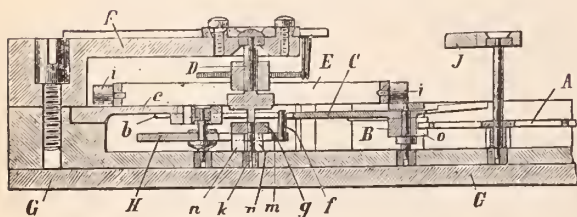

FIG. 2.

they had better have kept in their pockets, and that these patents are a source of income only to the patent offices. The silly ideas concentered into a tangible shape excite one's astonishment and frequently risibility, and are a strong evidence that the inventor wanted to produce something he knew not what, and succeeded most admirably in producing it. That the art of horology is exempt from these "novelties," would be too much to expect; the fastening of the movement appears to be a pet object, and often one will see the styles in vogue 100 or 150 years ago, revived; the "domes" and "dust covers" of English movements in common use for the last 80 to 100 years have

This is to certify that the undersigned have formed a limited partnership, pursuant to the provisions of the Revised Statute of the State of New York. That the name or firm under which said partnership is to be conducted is F. S. Maynard & Son. That the general nature of the business intended to be transacted is importing and dealing in foreign and domestic fruits and produce; that the names of the general and special partners interested therein are as follows: Edwin C. Maynard, who resides at Jersey City, N. J., is the general partner, and Isabel Maynard, who resides in the City of Brooklyn, State of New York, is the special partner. That the said Isabel Maynard has contributed the sum of \$5,000 as capital to the common stock and that said co-partnership is to commence on the first day of May, 1893, and is to terminate on the first day of May, 1898. Dated this first day of May, 1893.

E. C. MAYNARD, General partner.  
ISABEL MAYNARD, Special partner.

City and county of New York, ss.

On this first day of November, 1893, before me personally appeared Edwin C. Maynard and Isabel Maynard, to me known and known to me to be the individuals described in and who executed the foregoing instrument and they severally acknowledged to me that they executed the same.  
LEONARD S. WHEELER,  
Notary Public, N. Y. County.





# L. STRAUS & SONS,



IMPORTERS AND MANUFACTURERS,

China, Pottery and Glassware, 42, 44, 46 & 48 Warren St. and 116 Chambers St., N. Y.  
PARIS, CARLSBAD, RUDOLSTADT, LIMOGES, STEINSCHONAU.

## A NEW BOOK.

# Contents of THE PRACTICAL ELECTROPLATER By Martin Brunor

Aluminum. 292	Dip Silvering without Electricity. 58	Magnesium. 293	Shaving the Plates. 247
Aluminum Electroplating in America. 71	Double Speed Alarm Indicator. 111	Matt Aluminum. 168	Shaving the Wax Case. 209
Assayer's Weight. 277	Effects of Cyanogen on Health. 115	Matt Dipping. 45	Silver Oxidizing. 59
Assaying and Testing Sweeps. 275	Electrical Current. 256	Medium Solder. 94	Silverplating. 53
Backing the Shells. 244	Electrical Resistance. 255	Metallizing the Mold. 222	Small Outfit for Manufacturers. 285
Badge and Metal Oxidizing. 83	Electrical Smelting of Aluminum. 153	Method of Oxidizing. 59	Soft Cast Metal. 94
Bath for Agitating. 147	Electrical Unity. 254	Mixing Black Metal. 92	Soft Solder. 94
Beveling the Plates. 248	Electro-Deposition on Glass. 283	Modern Gilding. 5	Solder for Aluminum. 167
Black color on Brass. 86	Electro-Metallochrome. 77	Molding Composition. 205	Stopping Out the Mold. 220
Blackleading the Case before Molding. 210	Electro-Metallurgy of Copper. 296	Molding from Duplicates. 204	Straightening the Plates. 246
Blackleading the Form. 212	Electromotive Force. 255	Molding on Plates Mounted on Wood. 204	Striking Baths. 56
Blackleading the Mold. 220	Electroplating Dynamos. 9	Molding the Form. 214	Striking Solution. 224
Black Oxidizing for Brass and Bronze Articles. 61	Electroplating Plant. 99	Nickel Facing the Electrotypes. 251	Stripping Gold and Silver. 120
Black Platina Oxidizing. 59	Electroplating with Iron and Nickel. 281	Nickel or Silver Plating Batteries. 101	Stripping Metals. 119
Black Platina Oxidizing. 139	Electrotype Backing Metal. 244	Ni kel Plating. 129	Stripping the Copper from Old Plates. 235
Blowing Out the Mold. 221	Electrotyping. 193	Nickel Solution. 252	Stripping the Nickel from Electrotypes. 253
Brass and Bronze Gilding. 29	Etching Copper by Electricity. 151	Nohill's Rings. 84	Stripping Tin from Tinned Iron. 119
Brass Plating. 95	Evaporating the Water from the Wax. 238	Ohm's Law. 257	Sulphate of Copper Crystals. 226
Bright Dipping. 44	Filling the Case. 208	Oxidizing Brass Articles. 60	Sulphate of Copper Solution. 228
Bright Silvering by Battery. 57	Finishing the Plates. 248	Oxidizing Bronze Articles. 62	Table of Weights. 277
Bronze or Brass Cleaning. 43	Fire Gilding. 1	Oxidizing Copper. 61	Testing Gold. 273
Brown Color or Bronze Barbédienne. 86	Foot Lathe for Polishing Watch Cases, &c. 123	Photo Engraving for Newspapers. 259	Testing Silver. 273
Brunor's Perfected Dynamo. 11	Formulas for Brass and Bronze Dipping. 43	Plates Mounted on Metal. 250	The Bunsen Battery. 101
Building up the Mold. 218	Formulas for Brass Oxidizing. 79	Plates Mounted on Wood. 250	The Dynamo. 225
Burning Down the Mold. 217	Formulas for Britannia Metal. 91	Plating Directly on Iron. 131	The Foundry. 197
Buying a Dynamo. 89	French Coloring. 279	Platinum Plating. 171	The Galvanometer. 87
Cadmium and Silver Alloy Plating. 189	French Varnish. 261	Practical Hints, on Gilding. 109	The Grenet Battery. 105
Carbon Battery. 18	General Rules for Electroplating. 125	Preparing Electroplating Baths. 185	The Molding Case. 207
Casting White Metal. 93	Gilding by Electricity. 27	Preventing Rust on Steel. 113	The Smee Battery. 103
Cleaning the Plate. 245	Gilding by Immersion. 134	Problem of Commercial Electrolysis. 291	Tinning Solution. 240
Cleaning the Shells. 239	Gold and Silver, Testing. 295	Protection from Acids. 65	Tinning the Shells. 241
Colors of Gold. 274	Gold Assaying Report. 278	Purification of Mercury. 26	Tin Plating Process. 169
Conceal in Type. 313	Graphite. 210	Quantity. 256	To the Printer. 199
Connecting the Mold. 219	Half Tone Etching on Copper. 149	Recovering Gold. 137	Transparent Varnish. 262
Cutting Down the Mold. 84	Heavy Dip Gilding on Brass, without Electricity. 40	Recovering Jeweler's Waste. 269	Utilizing the Incandescent Circuit, or Direct Current Transformer. 289
Deep Black Color. 84	Hot Gilding by Battery. 33	Recovering Silver. 138	Voltmeters and Ammeters. 10
Depositing Gold on other Metals. 133	Hot Gilding by Electricity for Brass and Copper. 36	Refining Auriferous Metal. 271	Washing the Form. 212
Depositing the Shells. 232	Instructions. 19	Refining Sweeps. 263	Watch Case Gilding. 107
Deposition of Copper. 47	Lead. 294	Relative Conductivity of Metals. 258	Watch Case Plating. 121
Detection of Lead in Tin. 69	Lilac or Black Oxidizing. 64	Removing Gold from the Bath. 24	Watch Case Plating. 141
Dip Gilding without Battery. 37	List of Materials. 145	Removing the Green. 20	Weights and Measures. 93
Dip Gilding without Electricity, Matt Finish. 40		Removing the Shell from the Mold. 238	White Metal Britannia Alloy. 203
		Routing the Plates. 248	Wood Cuts. 203
		Satin Finish. 67	Zinc. 294

PRICE \$10.00, HANDSOMELY BOUND IN HALF MOROCCO. SOLD BY SUBSCRIPTION ONLY. NO AGENTS.

For Sale by EMILE BRUNOR, 93, 95 & 97 William St., N. Y.

## THE PRACTICAL ELECTROPLATER.

A COMPREHENSIVE AND PRACTICAL TREATISE ON ELECTROPLATING AND ELECTROTYPING BY MARTIN BRUNOR  
AMPLEY ILLUSTRATED.

EMILE BRUNOR, Publisher, 93 to 97 William St., N. Y.

Please send me one copy of The Practical Electroplater, for which I agree to pay you, or to your order, the sum of ten dollars on delivery.

Name,.....  
 Business,.....  
 Address,.....

From the Jewelers' Circular.  
Cut this Out and Return.

## BIG RETURNS MADE FOR OLD GOLD AND SILVER.

Check Forwarded 24 Hours After Receipt of Consignment.

### J. RATHBONE,

GOLD AND SILVER REFINER, ASSAYER AND SWEEPSMELTER,

Nos. 1 to 9 Matthewson St., Cor. Cove, Providence, R. I.

## Jules Jürgensen

OF COPENHAGEN.

The reputation these watches have maintained for Fifty Years has never been equalled, being made on strictly scientific principles and no expense spared to give the Best results in mechanism and timekeeping qualities.

SOLE AGENTS,

John C. Hyde's Sons,  
NO. 22 MAIDEN LANE.



# FERDINAND BING & Co.,

106 GRAND ST., N. Y.

—NEW DESIGNS IN—

China Clocks and Gilt Bronze Sets, Fine Painted Dresden Goods in Vases, Cups and Saucers, and Plates; Cararra Marble Statuary, French Cabinets and other Fancy Furniture.

## OUR IMPORT LINES

—OF—

# China, Glass and Bric-a-Brac

ARE COMPLETE.

We call particular attention to the following Specialties:

- LIMOGES CHINA AND SAXONIA WARE,
- ROYAL DRESDEN CHINA,
- SEVRES PORCELAIN,
- PARIS NOVELTIES,
- VIENNA CROWN WARE,
- ROYAL BONN & DELFT FAIENCE,
- AUSTRIAN GILT GLASS.

## CHARLES AHRENFELDT & SON,

50, 52 AND 54 MURRAY ST., NEW YORK.

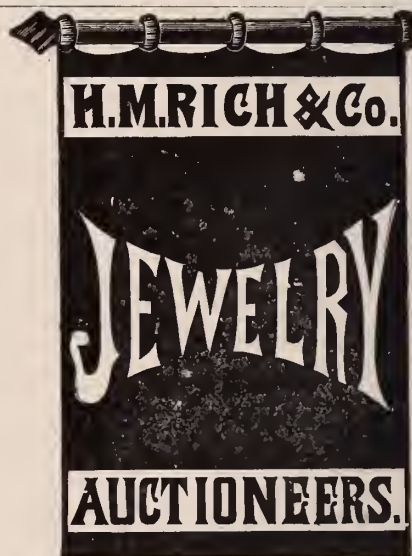

61 Hanover Street, Boston, Mass.

Sales made for Jewelers only in their established places of business. Can give best references of any auctioneers in America.

*All communications strictly confidential.*

ALBERT BERGER & CO  
47 MAIDEN LANE, N. Y.  
Spectacles & Optical Goods,  
GROUND LENSES A SPECIALTY.

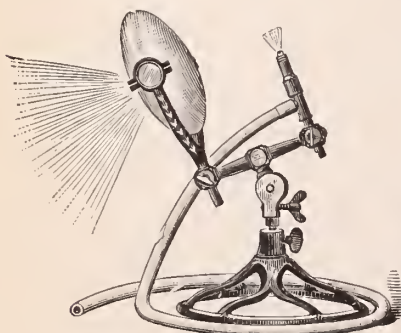

## F. W. GESSWEIN,

39 JOHN STREET,

NEW YORK.

# ENGRAVERS' REFLECTORS

FOR OIL OR GAS, SINGLE OR DOUBLE.

The Glass Reflecting Globe magnifies and concentrates the light, and can be adjusted to cast it on any desired point.

... Circulars and Price Lists on Application ...





## Latest Productions in Real Bronze.

THE demand for real bronzes has, despite the general depression in business, noticeably increased during the past year and is still growing. So marked has been their sale by Ferd. Bing & Co., 106 Grand St., New York, that this firm have decided to place bronzes among their principal lines this year, and will display one of the largest and richest assortments of busts, full figures and small cabinet ornaments that they have ever carried. Russian, Vienna and French bronzes will be shown in great variety of forms and finishes.

The artistic pieces depicted in the group herewith may serve to give a slight idea of the richness and beauty of their line. The centerpiece, "Peace and Liberty to the World" is a magnificent production by L. Madrassi, of Paris. It is in the rich Barbedienne finish and stands about 50 inches high. An ideal figure of Peace stands upon a globe surrounded by clouds. She holds in her right hand an olive branch and in her left a wreath, symbols of peace and liberty. At her feet is a cupid holding a ribbon on which is the inscription, *Pax Libertas Mundi*. "David," by Gaudez, the figure at

expression of face and the general outlines of the figure are remarkably lifelike.

At the right hand side is a piece in a lighter finish than the former two, "Merveil-

Between these larger pieces are two small busts, on miniature onyx, gilt bronze trimmed pedestals. One, the "Marquise," is in dark green finish, and the other, the "Soubrette," is in the Barbedienne finish. The two smaller pieces at the front of the group, will in beauty and artistic merit rank with almost any of the others. The

"Snake Charmer" is by Gregoire, and the group, "Cupid and Psyche," from the Paris Salon, 1892, is by Ferrani.

Another important line shown by Bing & Co., not represented in the illustration, comprises the small bronze cupids used as stands to hold the founts of rich Vienna and French porcelain miniature Princess lamps.

We are informed that Messrs. Doulton & Co., of pottery fame, shipped out to Chicago no less than 2,000 packages of their artistic productions. And see how the popularity of Doulton ware extends and the main potteries increase!—*Watchmaker, Jeweler and Silversmith.*

Venice in London no doubt called attention to beauty of Venetian glass as produced by modern exponents of the art of glass blowing; therefore among the new decanters in London, is one of tall spiral shape with Venetian wave and scale decoration

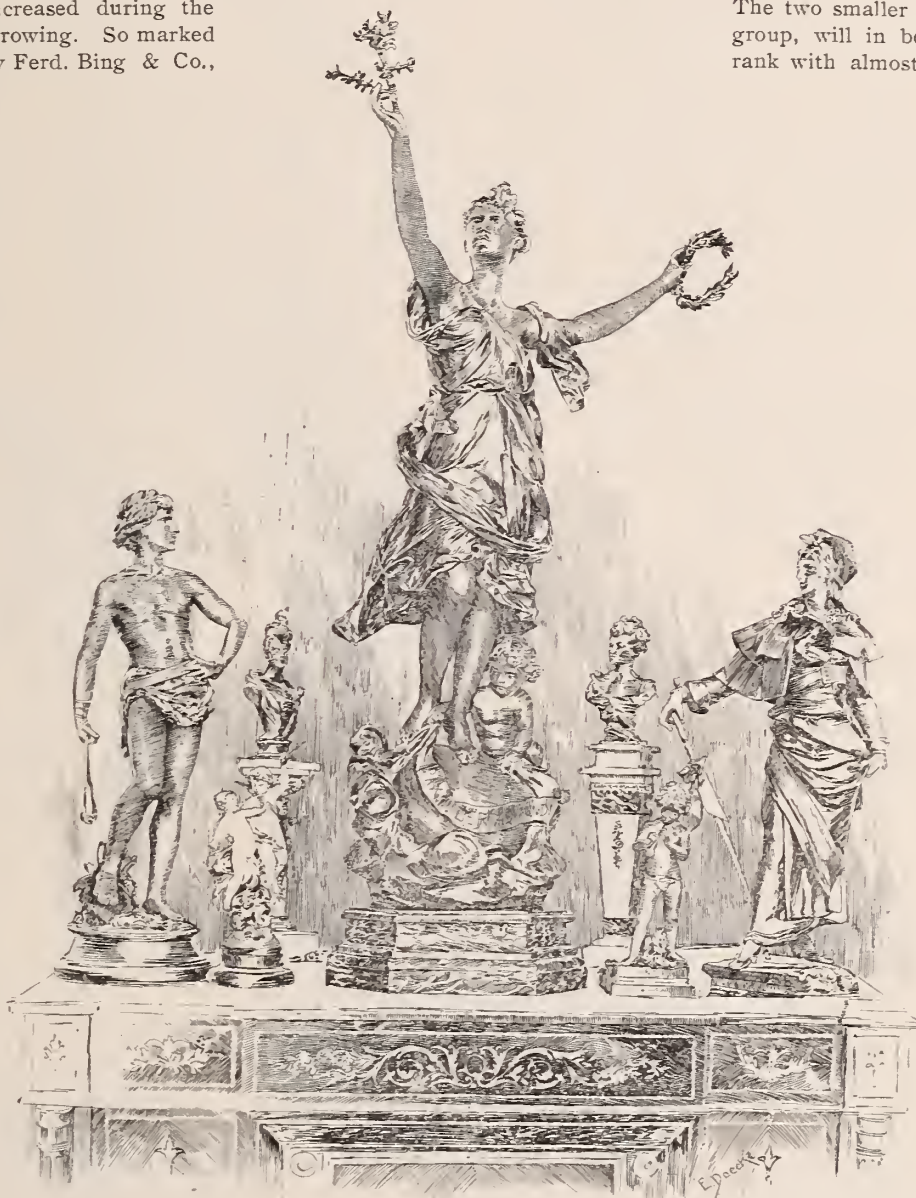

A GROUP OF REAL BRONZES SEEN AT FERD. BING & CO.'S.

the left, shows the slayer of Goliath in the act of throwing a stone from his sling. The

figure is characteristic of the dress of the time of Louis XVI.

The design is very graceful and pretty.



**The Connoisseur.**

(Continued from page 39.)

**The Rambler's Notes.**

WHAT THE RAMBLER SAW AND HEARD AMONG THE DEALERS IN ART POTTERY, CUT GLASS, BRONZES, ETC.

A. A. VANTINE & CO.'S PLANS. **A** SPECIAL run is now being made by A. A. Vantine & Co., 877 Broadway, New York, on fine fans of all grades, with water colored floral decorations. This firm will soon separate their retail and wholesale departments, each occupying different buildings. The former will continue at 877 and 879 Broadway, while the latter will occupy the three five story buildings at 18, 20 and 22 E. 18th St. This removal will take place about May 1st, and the increased accommodations will afford the firm an opportunity of showing an even larger and finer assortment of the rich Oriental lines handled by jewelers than they have previously been able to carry.

BEAUTIFUL IMPORT SAMPLES IN LIMOGES. **A**MONG the new pieces shown in the import samples of Limoges china, by F. W. Büning, 58 Murray St., New York, is a large and varied assortment of boudoir lamps and candlesticks. The many decorations range from the *bleu de four* and other solid colors to delicate

floral designs. Other pieces in rich variety are chocolate sets, tea caddies, cracker jars, and fish, game and writing sets. A new shape "Regine" is shown in a full line of novelties. It has an irregular border with an embossed leaf shape design. "Coffire" is the name of a new and pretty heart shape shown in the bonbonnières.

NEW BEAUTIES IN CUT GLASS.

**T**HE latest pattern in cut glass shown by T. B. Clark & Co., 53 Park Place, New York, is called the "Jewel." Though richer in appearance, it is of the same grade, weight and price, and cut on the same shapes as the strawberry, diamond and fan. A richly cut sixteen pointed star forms the centerpiece, and this is surrounded by a border of diamonds containing alternately star and checker work and strawberry diamond designs. The border is filled out with a deep fan cutting. The firm have also introduced a beautiful bowl called the "Carnation." The centre contains a conventional six leaf flower and this is surrounded by six multipointed large stars containing smaller stars at the centre. The effect is very rich and brilliant.

HINRICH'S & CO.'S RICH LIMOGES GOODS.

**H**INRICH'S & CO., 31 Park Place, New York, are this year making a specialty of rich Limoges cups and saucers and are going more exten-

sively into this line than ever before. In their import samples they are now displaying hundreds of different varieties of after-dinner chocolate, coffee, bouillon and moustache cups in entirely new shapes and original decorations. In connection with these they are also showing an elaborate assortment of chocolate sets, fish and game sets, toilet sets, cracker jars, chocolate pots, fruit dishes, brush and comb, pin and toilet trays, and all varieties of fancy plates, all of which are extremely rich and well suited for wedding or holiday presents.

BON VOYAGE, MR. ABBOT

**F.** P. ABBOT, of Haviland & Abbot, the New York agents for the Ch. Field Haviland china, sails for Europe to-day on the *Majestic*. He will be gone about two months.

THE PRINCIPAL COLORS IN WEDGWOOD.

**S**AGE green will be one of the principal colors in the new stock of Wedgwood Jasper novelties, to be shown by Maddock & Co., 21 Barclay St., New York. This and the blue have proved of late to be the most popular colors in this famous ware. The pieces which will be shown in the greatest variety will be Portland vases, jardinières, tea pots, sugars and creams, pin and pen trays, match boxes and a large new line of metal covered jugs.

THE RAMBLER.

**Rich Cut Glass**

AND

**DECORATED ART WARES.**

**Mt. Washington Glass Co.,**

**New Bedford, Mass.**

RICH DISPLAY OF GOODS AT

**New York Store: 46 Murray St.**

When you visit Chicago do not fail to inspect our full line of goods at the new store of Pairpoint Mfg. Co., 224 Wabash Avenue.

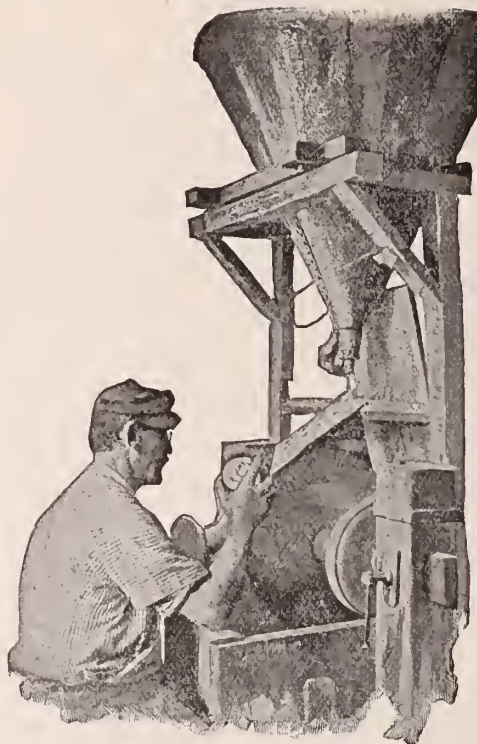

GLASS CUTTER AT WORK.



**M. L. READ & CO.,**

161 DORRANCE ST., PROVIDENCE, R. I.

THE Old

Reliable House

FOR STICK PINS AND WHITE STONE GOODS

**HENRY FERA, IMPORTER OF DIAMONDS**

AND DIAMOND BORTZ, Diamond Cutting and Polishing Establishment. 10 Maiden Lane, NEW YORK.



AMERICAN RAILWAY SUPPLY CO. 24 Park Place, NEW YORK.

**We Have Removed to**  
**57 MAIDEN LANE.**  
**LEONHARDT & CURRAN,**  
 MANUFACTURERS OF DIAMOND MOUNTINGS.



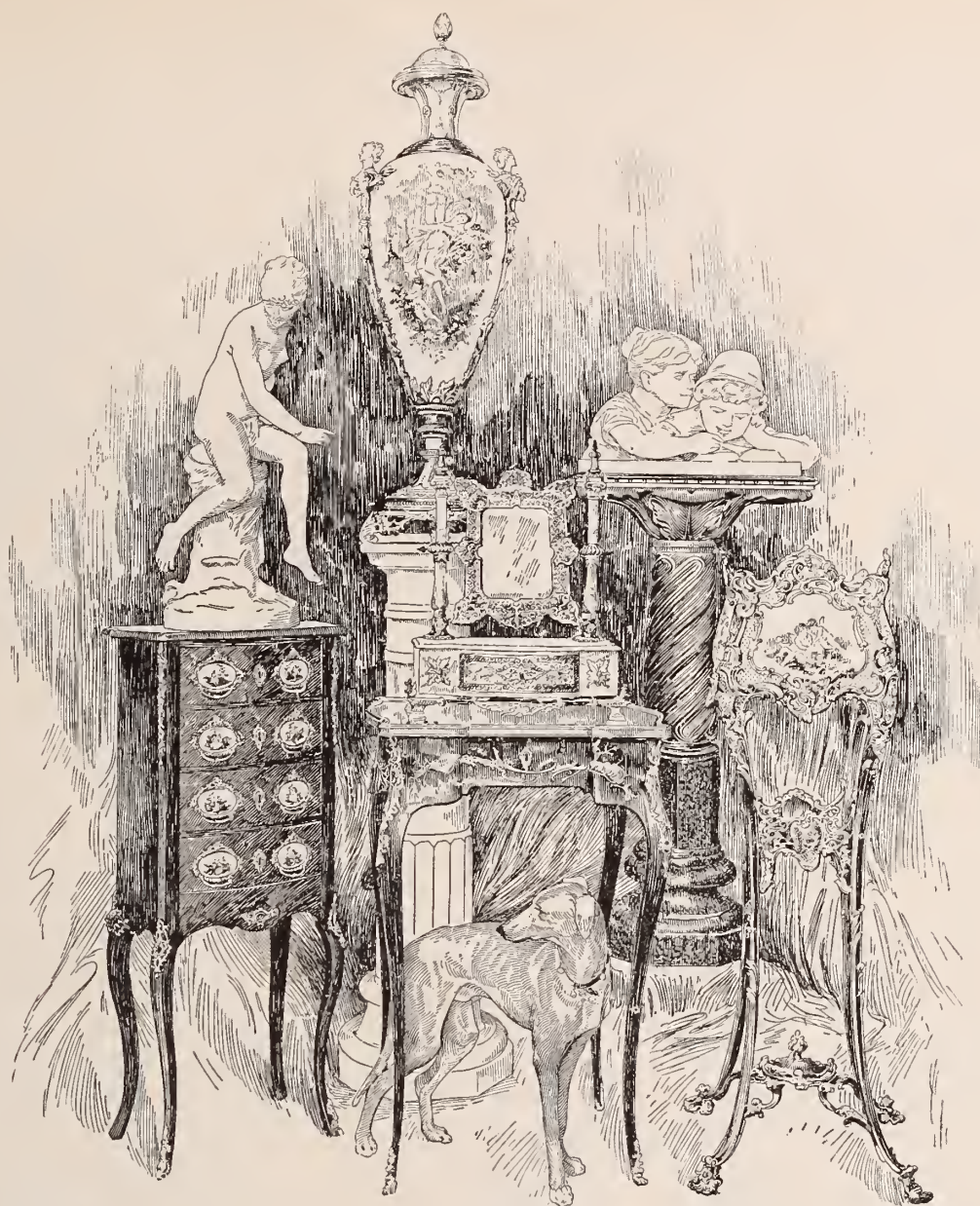

OUR lines of *IMPORT SAMPLES FOR 1894*, are richer and more varied than ever, and far surpass in quality, design and price, any we have hitherto shown.

The accompanying illustration represents some of our recent importations of Art Goods, Artistic Furniture, Bronzes, Bric a-Brac, Etc., which we have in complete assortments. It is *MOST IMPORTANT* that all buyers should examine these goods before placing orders.

**GEO. BORGFELDT & CO.,**

18, 20, 22 WASHINGTON PLACE, Cor. Greene St.,

**NEW YORK.**



The Other Side of Life.

It is a rather remarkable thing that we can see through almost any kind of glass but a glass eye.

SHE—Papa says you must not stay after 11 o'clock.

HE—It's 9 o'clock now.

SHE—Mercy! we have only two hours to say good night.—New York Weekly.

"How does the alarm clock work, all right?"

"Splendidly; it entertains the baby and the rest of us can sleep."—Chicago Tribune.

KATHRYN—Frank was saying sweet nothings to you again last night.

HATTIE (showing a jeweled finger)—Do you call that nothing, my dear?—Detroit Free Press.

PATERFAMILIAS—What on earth did that young man mean by paying you such an unconscionable long call last night?

MARY—Oh, Papa, it was purely an accident, you see! The clock stopped at half past twelve.—Puck.

BLIGHTED AFFECTIONS.

"Why did you name \$100 as the damages in your breach of promise suit?"

"That's the price of my watch. When he broke off the engagement my heart beat so fast that it stopped the timepiece."—Chicago Record.

AN EYE FOR BUSINESS.

It was growing dusk when a tall man emerged from the jungle and, with a furtive glance to the right and left, quickened his pace.

His garb betokened him a Brahmin of high estate.

A smile illumined his sinister visage.

"In two days—"

His face fairly glowed with gratulation.

"I shall be able to hold the monocle in my eye, and then—"

As he advanced his step grew yet more elastic.

"I guess there won't be any more trouble about my preserving my caste."—Puck.

CONSISTENCY is a jewel often sold to pay the price of success.

—Puck.

FROM A SOCIETY JOURNAL DE FUTURO.

"The defendant, beautifully gowned in cream satin with garniture of pearls, entered the courtroom leaning upon her father's arm, while the plaintiff waited at the bar.

"The souvenirs for the co-respondents were corsage pins set with diamonds, and cuff buttons in the shape of fern leaves."—Puck.

THE DUEL.

THE gingham dog and the calico cat Side by side on the table sat; 'Twas half past twelve, and, what do you think,



VERY PARTICULAR.

MRS. LILY WHITE.—Sec, heah, Boss! Dis heah ring won't make a black mark on mah finger, will it?—Puck.

Neither of them had slept a wink! And the old Dutch clock and Chinese plate Seemed to know, as sure as fate, There was going to be an awful spat.

(I wasn't there—I simply state What was told to me by the Chinese plate.)

The gingham dog went "bow-wow-wow!" And the calico cat replied "me-ow!" And the air was streaked for an hour or so With fragments of giugham and calico, While the old Dutch clock in the chimney place Up with its hands before its face, For it always dreaded a family row!

(Now, mind, I'm simply telling you What the old Dutch clock declares is true.)

The Chinese plate looked very blue And wailed: "oh, dear, what shall we do!" But the gingham dog and calico cat Wallowed this way and tumbled that And utilized every tooth and claw In the awfulest way you ever saw— And, oh! how the gingham and calico flew!

(Don't think that I exaggerate— I got my news from the Chinese plate.)

Next morning where the two had sat, They found no trace of the dog or cat; And some folks think unto this day That burglars stole that pair away; But the truth about that cat and pup Is that they ate each other up— Now, what do you really think of that?

(The old Dutch clock, it told me so, And that is how I came to know.)

—Eugene Field in the Chicago News.

Enterprising Jewelers Catch On!



OBVERSE



REVERSE



BACK

Jewish Shekel, Masonic Mark or Pocket Piece.

THE LATEST AND BEST SELLING NOVELTY.

The mark is struck in coin silver; by using either the obverse or reverse of the coin, the back being the same in either case, and permitting of the purchaser's name, blue lodge, chapter and individual mark, with date of same being engraved thereon, as shown in cut above.

Price, without engraving, ONE DOLLAR. Engraved Mark, Dates, etc., 75c. EXTRA.

Liberal Discount to the Trade.

CHAS. C. WILLSON, MANUFACTURING JEWELER, READING PA.

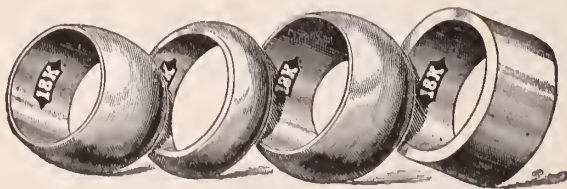

Band Rings metal lapped. Full value allowed for old gold.

PLAIN SOLID GOLD RINGS.

HILDRETH MFG. CO.,

53 MAIDEN LANE,

NEW YORK.

Headquarters

FOR ELECTRIC & PORTABLE Watchman's Clocks

Lowest Prices. Latest Improvements, Patents 1888-1893. Send for Circular.

E. O. HAUSBURG,

41 Maiden Lane, New York. THE "ALERT."

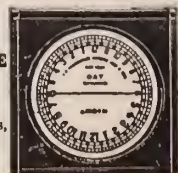

Price, Complete \$10.00







No. 1718

# HINRICHS & CO.,

29 AND 31 PARK PLACE, NEW YORK.

## Complete Lines of Import Samples

ESPECIALLY SELECTED FOR THE JEWELRY TRADE.

### BRIC-A-BRAC and ART POTTERY.

Doulton, Worcester, Royal Vienna, Teplitz, Dresden, Sevres, Coalport, Austrian Faience, Bisque Figures and Candelabras.

BOHEMIAN AND FRENCH CHRYSANTHEMUM VASES and Bouquet Holders, Atomizers, Cologne Bottles and Jewel Boxes.



No. 1347.



#### SPECIALTIES IN LIMOGES CHINA.

A. D. Cups and Saucers, Chocolate Cups, Teas and Coffees, Mustache Cups, designs and decorations entirely new and exclusively our own.

OUR SPRING STOCK was never more complete than now, and we never had a finer line of goods. These we will sell at greatly reduced prices for the next three months.

When you come to the city, don't fail to give us a call. Catalogues and Price Lists on application.



No. 1326/15.

**WOOD & HUGHES,**  
STERLING SILVERWARE MANUFACTURERS  
New York Agents for the Derby Silver Co.'s  
FINE QUADRUPLE PLATED WARE,  
NO. 16 JOHN STREET, NEW YORK  
206 Kearney St., San Francisco, Cal.  
HASKELL & MUEGGE, Agents.

### "Old English" Coffee Spoon.



DESIGN PATENTED.

Towle Mfg. Co.,

MANUFACTURERS OF

STERLING SILVERWARE.

NEWBURYPORT: No. 214 Merrimack St. CHICAGO: Nos. 149 & 151 State St.

ESTABLISHED 1870.

### J. L. CLARK,

SWEEP SMELTER AND REFINER OF GOLD AND SILVER.

Buys every kind of Gold and Silverware, Jewelry, Watches and Platinum. Full market value paid.

No. 724 Filbert Street, Philadelphia, Pa.

SEND BY EXPRESS or Registered Mail. If my price is not satisfactory, I will return all articles.

**"TIME IS MONEY"**  
SEND YOUR PRESCRIPTIONS  
AND REPAIR WORK WHERE  
IT IS DONE ACCURATELY WITH-  
OUT DELAY.  
**E. KIRSTEIN'S SONS CO.**  
SEND FOR CATALOGUE. ROCHESTER, N.Y.

### CROUCH & FITZGERALD.

Jewelry Trunks  
and Cases  
161

Broadway,  
Bet. Cortlandt and  
Liberty Sts.,  
688 B'way,  
701 6th Ave.,  
NEW YORK.

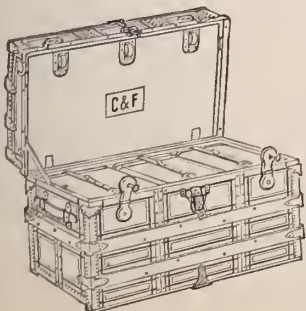

### If Your Sales Are Not Satisfactory

ADDRESS

DE B. O. SCOTT,

20 Murray Street, New York.

AUCTIONEER.

Specialties: Watches, Clocks, Bric-a-Brac, &c.

Write for particulars and references

### AWARD AT WORLD'S FAIR, CHICAGO, 1893

The Providence Shell Works.  
**W. K. Potter,**  
346 Westminster St., Providence, R. I.



Tortoise Shell Goods, Combs, Hair Orna-  
ments, Jewelry, Etc.  
Shell Work made to order on contract. Repairing for  
the trade in all its branches.



# PEARLS.

**M. D. ROTHSCHILD,**

NEW YORK: 41 & 43 MAIDEN LANE

LONDON: 15 HOLBORN VIADUCT

PARIS: 58 RUE LAFFITTE.

**FANCY DIALS** TO FIT AMERICAN WATCHES.  
**\$6.00 per doz.** IN FLAT SECONDS.  
**\$7.20 per doz.** IN PRESSED SECONDS  
 Jobbers, Importers and Retailers generally, will be re-  
 bated by sending to us any Dials of our make which they  
 may have on hand.  
**O'HARA WALTHAM DIAL CO.,** Waltham, Mass.

## CAMPBELL-METCALF SILVER CO.



176 Broadway, N. Y., Room 14. 66 Stewart St., Prov., R. I.  
 Mills Bldg., San Francisco, 8th Floor, Room 1.

# OPALS.

**E. E. KIPLING,**

182 Broadway, New York.

 ELEVATOR ENTRANCE, 2 JOHN ST.

## S. F. MYERS & CO.,

WHOLESALE JEWELERS,

MYERS BUILDINGS, - - NEW YORK.

1894 ISSUE, No. 38,

### OUR ROYAL CATALOGUE

Illustrates all that is new, unique and desirable in  
 everything that pertains to jewelry.

Sent free to dealers who have not received it.

TWENTY-TWO DEPARTMENTS.

SEVEN DOUBLE FLOORS.

Myers Buildings, 48-50 Maiden Lane, New York.  
 33-35 Liberty St.,

## S. P. HOWARD,

Gold and Silver Assayer.

**Refiner and Sweep Smelter,**

33 MAIDEN LANE, NEW YORK.

Smelting and Refining Works,

28 & 30 Cumberland Street, Brooklyn, N. Y.

Specialties: Sweepings, Gold, Silver and Platinum

FRENCH ENGLISH  
 CLOCKS AND HALL CLOCKS AND  
 MATERIALS. MATERIALS  
**CHAS. JACQUES CLOCK CO.,** 22 CORTLANDT ST., N. Y.

## L. LELONG & BRO.,

GOLD AND SILVER

**Refiners, Assayers AND Sweep Smelters,**

◁ SOUTHWEST CORNER HALSEY AND MARSHALL STREETS, ▷

**NEWARK, N. J.**

**SWEEPINGS A SPECIALTY.**

## J. SCHAWEL & CO., 29 John St., N. Y

GOLD & SILVER REFINERS, ASSAYERS & SWEEP SMELTERS.

STERLING SILVER, 925/1000 FINE IN SHEET AND WIRE.

Soft Platinum, Sheet and Wire for Manufacturing Jewelers.

## LIST REDUCED,

FOR 60 DAYS ONLY,

And STRICTLY for Cash With Order.

The List of the

### FRANCIS ENGRAVING MACHINE

Has been in some respects greatly reduced.

The Plain Bench Machine Reduced from \$75 to \$50.

For further particulars write to your Jobber or  
 to the Manufacturer,

**A. E. FRANCIS,**

780 Cedar Avenue, Cleveland, Ohio.

February 15, 1894.

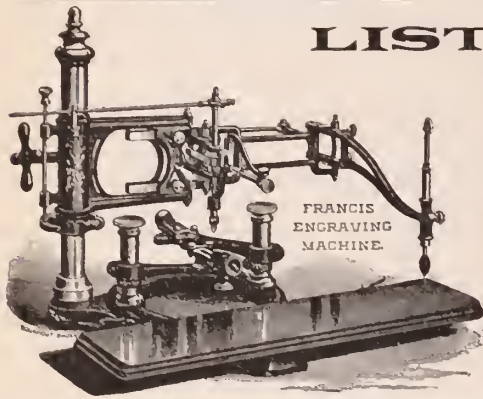

FRANCIS  
 ENGRAVING  
 MACHINE.

## WM. BIRMINGHAM & CO.,

MANUFACTURERS OF

All Kinds of Leather Spectacle and Eye Glass

### CASES,

728 Arch Street, PHILADELPHIA, PA.

## J. PRINCE,

Jewelry Auctioneer,

At liberty from January 1st. 1894. Retail  
 Jewelers only. Address,

Rooms 9 & 10, 137 BROADWAY

N. Y. CITY.

# ALBERT LORSCH & Co.,

37 MAIDEN LANE, NEW YORK.

Branch, 167 Weybosset Street, Providence, R. I.

—♦— IMPORTERS OF DIAMONDS, —♦—

Rose Diamonds, Rubies, Sapphires, Emeralds, Opals, Moonstones,

Fancy and Imitation Stones, Novelties.

..... SOLE OWNERS AND IMPORTERS OF

*The Sumatra Gem.*

REG'D. UNEQUALLED IN  
 BRILLIANCY AND  
 HARDNESS

HIGHEST AWARD AT THE COLUMBIAN EXPOSITION, CHICAGO, 1893.

**IT PAYS** TO KEEP IN TOUCH WITH TRADE AFFAIRS.  
**THE JEWELERS CIRCULAR,** For 4c. a Week will do it. **Subscribe.**

1869-1894=Twenty-five Years, Oldest, Best, Brightest, Newest, =The Jewelers' Circular.



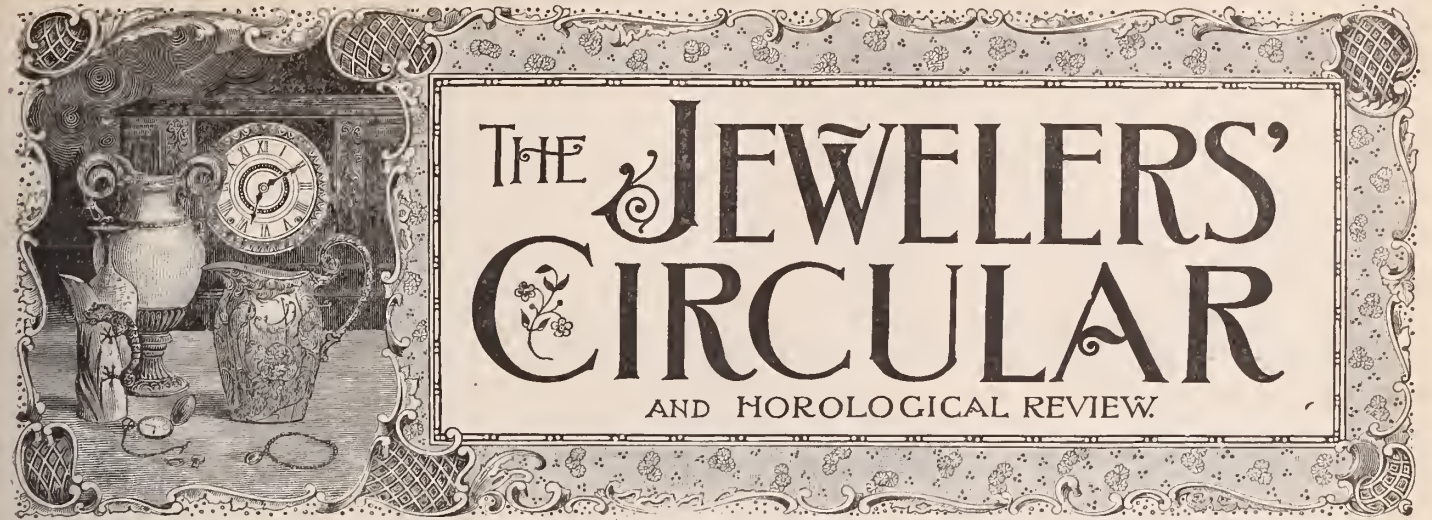

Copyright by THE JEWELERS' CIRCULAR PUB. CO.

189 Broadway, New York.

Entered at the Post Office in N. Y. as second-class matter.

VOL. XXVIII.

NEW YORK, WEDNESDAY, FEBRUARY 28, 1894.

No. 4.

### MODERN ECCLESIASTICAL SILVER WARE.

ECCLESIASTICAL silver, plate and jeweled ware form one of the most interesting lines of the silversmith, both by

reason of its association with the past history of the craft and of the great advancement made in the manufacture of these pieces within the last few years. It is well-known that during the middle ages the chief work of the silversmiths and goldsmiths was the making of jewels and plate used by the church, this work keeping the art alive for many centuries. In fact until comparatively recent times the fame of many of the greatest jewelers, even Cellini, was acquired principally through their church work.

Of late years the superior pieces now seen in our churches, which a few centuries ago would have been universally admired, now excite but little comment.

This is due to the great strides which have been made by the American silversmiths in their church work, within recent years. This was

strongly shown by the interest excited by some of the ecclesiastical masterpieces at the World's Fair.

Gorham Mfg. Co. where some of the chief pieces from the ecclesiastical department of the company's World's Fair exhibit, were displayed.

The principal attraction was the wonderful altar cross illustrated in THE CIRCULAR of June 21st last, but almost equally important was the elaborate alms bason, which goes with the cross and which is depicted in the illustration. This piece which is for use in the Episcopal church, is of solid silver, gold palted and richly jeweled, enameled and chased. It is 20½ inches in diameter and is valued at \$2,200. It is considered the most elaborate alms bason ever made.

The design is Romanesque and the same general plan is observed in this as in its companion piece, the altar cross, both in character of design and richness of materials. The main design is a cross, in the center of



REMARKABLE ALMS BASON, VALUED AT \$2,200.

During the past week, the crowds which through upper Broadway, New York, have evinced great interest in the window of the

which is pictured the "Adoration of the Magi," in colored enamel, and between the arms of the cross are scenes in



# DEITSCH BROS.,

7 EAST 17TH ST., NEW YORK.

## LEATHER GOODS.

EBONY AND SILVER COMBINATIONS.

ORIGINATORS AND MAKERS OF

NOVELTIES IN LEATHER AND STERLING SILVER COMBINATIONS.



\*\*\*\*\*

**CROSS & BEGUELIN,**

17 MAIDEN LANE, NEW YORK,

ALL GRADES OF SWISS AND AMERICAN WATCHES, DIAMONDS, GOLD AND ROLLED PLATE JEWELRY, OPERA AND FIELD GLASSES, TOOLS AND MATERIAL.

SOLE AGENTS FOR THE **Rockford Watch Co. MATERIAL.** MANUFACTURERS OF THE **Centennial Watches.**

SEND FOR OUR WATCH MATERIAL AND TOOL PRICE LIST FOR 1894.

\*\*\*\*\*

### AMERICAN SYNDICATE OF Jewelers' Auctioneers.

ESTABLISHED for the sole purpose of conducting sales for established Jewelers in the United States, Canada and Mexico. We do not sacrifice your goods. We take no sales on a percentage. Our terms are strictly one-half the profits realized on all goods sold. We guarantee you against any loss. We pay all our own expenses; we don't ask you to pay one cent of expense on our account. We buy stocks complete as well as sell them. If your stock is small, or your assortment is not complete, we will furnish from one to ten thousand dollars worth of any kind of stock you may need and in which you need not invest one penny. Don't make any arrangements with others until you read our pamphlet which we will send you free, giving you full particulars of our style of doing business, and the liberal offers we make to Jewelers. We don't care how small your stock is, we will furnish all the stock you need to make a successful sale. We challenge the world for any fairer or more liberal propositions than we make Jewelers. Don't fail to send us your address, and we will send you our business pamphlet, which gives you full explanations as to our terms and style of doing business. Address,

### AMERICAN SYNDICATE OF JEWELERS' AUCTIONEERS.

Offices: 20 WEST 14th STREET, NEW YORK. 611 PENN AVE., WASHINGTON, D. C.

## "THE BEST BUTTON MADE."

THE KREMENTZ

IN GOLD

IN ROLLED PLATE

FROM

KREMENTZ & CO.

ONE PIECE

FROM

ALL JOBBERS



### COLLAR BUTTON.

IS THE ORIGINAL ONE PIECE BUTTON.

IS STILL THE BEST AND STILL UNSURPASSED.

Sold by all wholesale dealers at manufacturer's price.

**A. N. CLARK,** PLAINVILLE, CONN.

### Manufacturer of the Celebrated LOOP WATCH KEY.

The Best for the Price in the World. CROSBY'S JEWELING TOOLS IMPROVED.

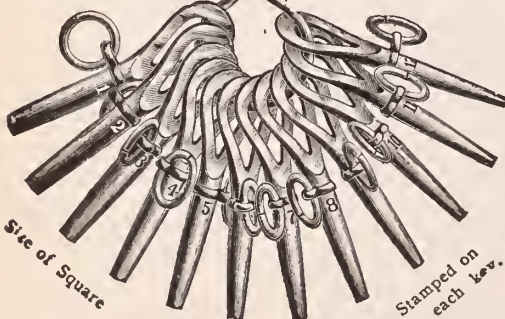

Size of Square

Stamped on each key.

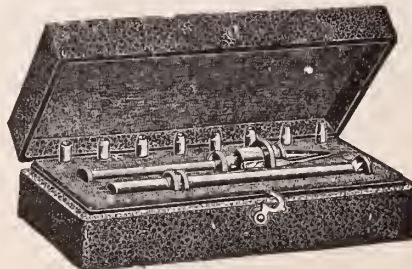

Will quote royalty or price for the manufacturing of articles of real worth.

### CAMPBELL-METCALF SILVER CO.

Choice Concepts IN		Sterling Silver ONLY.
--------------------	--	-----------------------

2 Maiden Lane, N. Y., with Holmes & Edwards Silver Co. 66 Stewart St., Prov., R. I. Mills Bldg., San Francisco, 8th Floor, Room 1.

JACOT & SON IMPORTERS AND MANUFACTURERS OF MUSICAL BOXES 298 BROADWAY NEW YORK



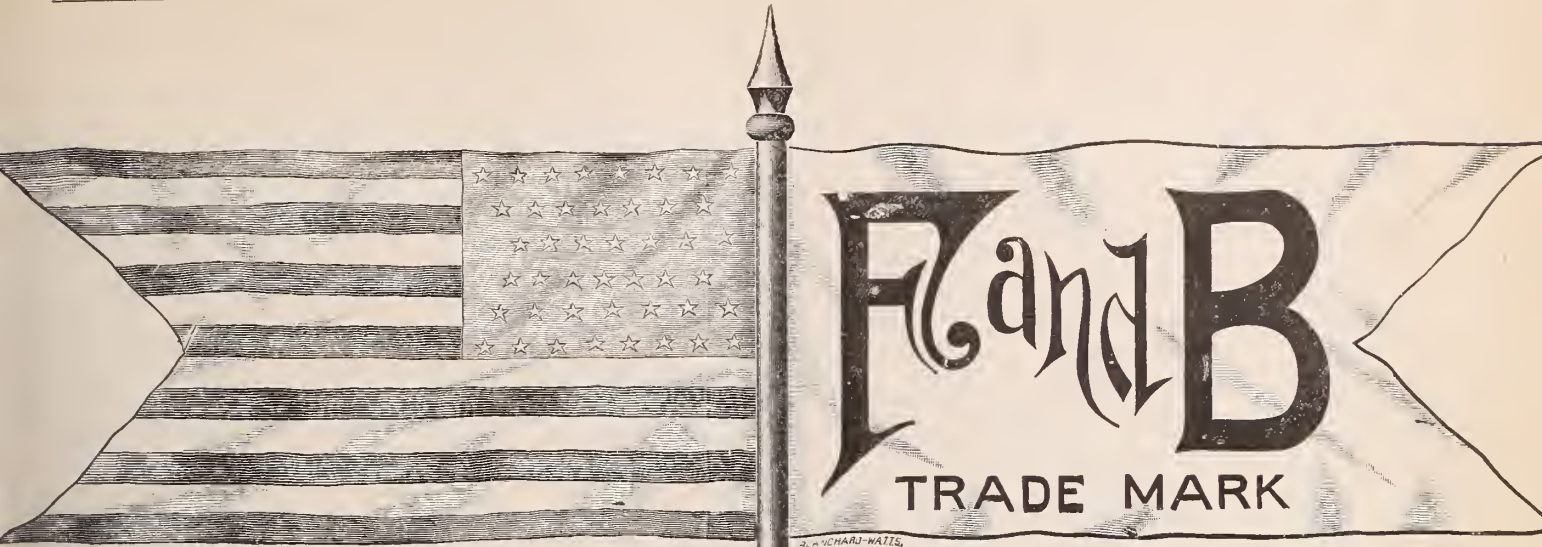

Our American F. & B.  $\frac{1}{10}$  Gold Chains will assay 10 K. 1-10 gold, and are guaranteed for ten years.

Our regular line of Chains is made of heavy gold plate, finely finished, and guaranteed for five years.



**Chains**  
Our new line of chains will assay 10 karat 1-10 gold. All gold soldered.  
**American F. & B. 1-10 gold.**

WE RECEIVED  
**4 MEDALS**  
AT THE WORLD'S FAIR.

Mount Hope Button.

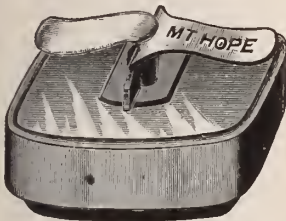

CLOSED.

<p><b>Watch Chains for Gentlemen</b></p> <p>These goods are of fine quality, and guaranteed to give satisfaction. Some recently added have sold far beyond expectation. They are made of heavy rolled plate in all sizes and patterns.</p>	<p><b>Watch Chains for Ladies</b></p> <p>Our Victoria and Princess chains are neat and pretty. They are made in all bright, Roman and bright platinum and bright gold, and have one or two charms.</p>
--	--

Mount Hope Button

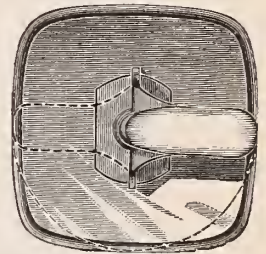

OPEN.

<p><b>Charms</b></p> <p>This line is adapted to ladies' or gentlemen's chains, and includes a number of heart charms in Roman, bright and satin finish, with stones and without.</p>	<p><b>Hair Chain Mountings</b></p> <p>In solid gold and rolled plate. We are headed up and made every thing desirable in this line.</p>	<p><b>Bracelets</b></p> <p>We make a large stock of curb bracelets in five sizes, besides the graduated links, with padlocks and snaps, in chased and plain polished, Roman, rolled silver plate and sterling silver. Also padlocks with keys and a push snap.</p>
--	---	--

<p><b>Pins</b></p> <p>Our large line of lace and cuff pins comprise many desirable patterns in gold fronts engraved and trimmed. Also includes baby pins and scarf pins.</p>	<p><b>"Mt. Hope" Buttons</b></p> <p>These are superior to any button in the world. They are easy to put in and easy to take out of the cuff.</p>	<p><b>Link Buttons</b></p> <p>This line has increased rapidly with us, and is very low in price, embracing all styles in Roman, chased, engraved and plain, with and without stones, and some in imitation.</p>	<p><b>Crosses</b></p> <p>We make four sizes of gold filled in plain, engraved and set with stones, and suitable for our neck chains.</p>
--	--	---	--

<p><b>Sterling Silver and Solid Gold Sword Scarf Pins</b></p>	<p><b>Glove Buttoners</b></p> <p>We make the Interlocking and one with a twist handle in gold rolled plate and silver rolled plate.</p>	<p><b>Earrings</b></p> <p>This line includes many pretty patterns in gold fronts engraved, some with pretty mountings and a small line of drop tops.</p>	<p><b>Neck Chains</b></p> <p>We make a variety of neck-chains in bright and Roman, with snaps.</p>	<p><b>Sterling Silver Bracelets and Padlocks</b></p>
---	---	--	--	--

	<p><b>Gold Lockets Set with Diamonds</b></p> <p>These lockets are made of 10 karat gold throughout and set with brilliant diamonds. They cannot be surpassed in finish or cheapness of price.</p>	<p><b>Gold Lockets Engraved</b></p> <p>These lockets are also made of 10 karat gold throughout, with beautiful designs engraved, and the price is so low that they cannot fail to be in great demand.</p>	<p><b>Gold Front Lockets</b></p> <p>This line is very extensive. Many are plain polished, others are engraved, with and without stones.</p>	<p><b>Rolled-Plate Lockets</b></p> <p>This line is almost endless, and consists of nearly every conceivable shape, size and style. Some are set with imitation diamonds, rubies and sapphires.</p>	
--	---	---	---	--	--

We have put upon the market a line of Gentlemen's Chains and Ladies' Chain Bracelets made of 1-10 gold stock. Every joint is soldered with gold, and every Chain or Bracelet will assay more than 1-10 gold. They are our AMERICAN F. & B. 1-10 GOLD goods, and are so stamped. Bar, Chain and Swivel are stamped 1-10 gold.

**FOSTER & BAILEY, Providence, R. I.**



the life of Christ from the Annunciation to the Ascension, such as the birth, baptism, last supper, crucifixion, removal from the cross and resurrection. These eight panels are in repoussé chasing, oxidized. On the border, at the extremities of the cross, are

## SEEING



is believing, and to see the product of our Optical prescription department, will lead you to believe that your popularity as an Optician will increase if we fill your orders.

**QUEEN & CO.,**

MANUFACTURING OPTICIANS,

1010 Chestnut Street, Philadelphia.

**WM. BIRMINGHAM & CO.,**

MANUFACTURERS OF

All Kinds of Leather Spectacle and Eye Glass

**CASES,**

728 Arch Street, PHILADELPHIA, PA.

four oxidized medallions with the signs of the four evangelists, Matthew, Mark, Luke and John, in bas relief. The border is also enameled and studded with garnets, malachites, crystals and lapis lazuli in open settings.

In the same series is a communion set consisting of two chalices, two patens and two flagons. They are in keeping with the cross and bason in their construction throughout, and are probably the most expensive articles of the kind ever constructed in modern times. The entire series in richness of material and exquisite workmanship is regarded by the experienced men who have had their construction in charge as remarkable specimens of decorative art in ecclesiastical work.

### Isaac Weiner Bobs up in the Clutches of the Police.

HARTFORD, Conn., Feb. 23. — Isaac Weiner, who opened a jewelry store about three weeks ago in Portland, in the building formerly occupied by George Scoville, jeweler, who committed suicide, was arrested in New Britain, Saturday, charged with confiscating goods which were placed in his hands for repairs.

After occupying the store a short time he abandoned the business and suddenly left town. It was first supposed that he had gone away on a business trip, but his failure to return after a reasonable time established the opinion that he had permanently left the place.

### The Peddlers' License in Kentucky to be Raised.

LOUISVILLE, Ky., Feb. 23.—There is now pending in the Legislature a bill having for its purpose the protection of Kentucky merchants against itinerant vendors of goods, wares or merchandise from other States. The present statute declares all such persons to be peddlers, and requires each of them to take out a peddlers' license, which now costs \$20 for the whole State or \$5 for one county. The pending bill, which has been reported favorably, raises the license fee to \$100 for the entire State or \$25 for any one county, for one year. This will have the effect of equalizing the burden of taxation between the itinerant vendors and resident merchants, who pay an ad valorem State tax annually, or will prevent the former from doing business in Kentucky.

The jewelry trade has suffered greatly in the past from the incursions of vendors of cheap wares and will profit from the operation of the Bowden Bill if it becomes a law, as now seems likely. Every person coming within the class denominated as "peddlers" is required by the new bill to take out separate licenses for himself and each person in his employ. A license cannot be issued to a firm or corporation and only authorizes the individual to whom it is issued to sell under it. A petition sent up to the capital from Louisville bears the signatures of many of our prominent jewelers.

The passage of the bill will in no way affect traveling salesmen selling by samples for future delivery.

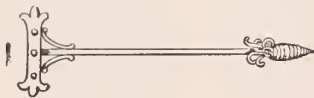

**GEO. W. SHIBLER & CO.**



179 BROADWAY, N.Y.

OUR OWN ★

## "COLUMBIAN"

Fifty Punch Staking Tool, LEADS ALL OTHERS in STYLE, FINISH and ACCURACY. Hundreds of practical Watch Makers pronounce it the BEST.

Nickel frame, mahogany base, extra fine tempered steel punches and stumps.

—★ FULLY WARRANTED. ★—

For full description send five cents in stamps, with business card, for New Catalogue of OVER ONE THOUSAND varieties of fine Watch and Bench Tools of OUR OWN MAKE, many entirely new.

**O. W. BULLOCK & CO.,**  
SPRINGFIELD, MASS.

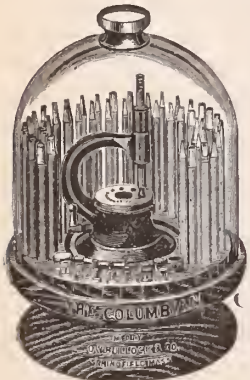

**VICTOR.** ☉ ☉

SIMPLEST FEED. ALWAYS THE SAME.  
GUARANTEED FOR ONE YEAR.

## THE VICTOR FOUNTAIN PEN

(Pat. Feb. 4, 1890.)

THE BOSTON PEN CO.,

N. C. Whitaker & Co., Proprietors.

363 Washington Street, Boston, Mass.,

Manufacturers of finest quality

TORTOISE : SHELL : AND : HORN : GOODS  
in every variety. Also Aluminum Hair Pins.

Send for Illustrated Pen Price List No. 1.

WHITE'S EYE SHADE. **W. B. WHITE & SON**

MANUFACTURERS OF



Spectacle and Eye Glass  
CASES

90 SOUTH STREET, BOSTON.

Special Cases made to order for Optical Trade. Cases for Trial Lenses. Opera Glasses recovered, etc. Charismatic Spectacle Cases, Metal Bound Leather Cases for combs, scissors, etc. Over forty kinds of cases manufactured.

**THEODORE C. STEINHAUS,**

— MANUFACTURER OF —

## Fine Cases and Trays

For JEWELRY, SILVERWARE, &c.

SAMPLE CASES AND TRAYS FOR TRAVELERS.

Fancy Hard Wood Chests for Silverware, &c.

Linings, Cushions, Mounting, etc., for Silver Novelties.

10 MAIDEN LANE, NEW YORK.



*Pairpoint's*  
THE  
MAKERS OF

Hollow and  
"1880" Flat Ware.



No. 6300. ORANGE HOLDER.

**MFG. COMPANY,**  
Gold and Silver Plate.

FACTORIES:  
New Bedford,  
Mass.

HEADQUARTERS FOR  
RICH CUT GLASS.  
COLONIAL,  
ROYAL FLEMISH,  
CROWN MILANO.  
Decorated Art Glass.



No. 2697. EMBOSSED CANDLESTICK

SALESROOMS:

NEW YORK, - - 20 Maiden Lane.  
CHICAGO, - - 224 Wabash Avenue.  
SAN FRANCISCO, 220 Sutter Street.



No. 6301. ORANGE HOLDER.

**A. J. LOGAN,**  
MANUFACTURER OF  
WATCH TOOLS, HAIR SPRINGS AND  
WATCH MATERIALS.  
◁ New Catalogue just issued, Sent on Application. ▷  
WALTHAM, MASS.

If Your Sales  
Are Not Satisfactory

ADDRESS  
**DE B. O. SCOTT,**  
20 Murray Street, New York.  
AUCTIONEER.

Specialties: Watches, Clocks, Bric-a-Brac, &c.  
Write for particulars and references

AWARD AT WORLD'S FAIR, CHICAGO, 1893  
The Providence Shell Works.  
**W. K. Potter,**  
346 Westminster St., Providence, R. I.



Tortoise Shell Goods, Combs, Hair Ornaments, Jewelry, Etc.  
Shell Work made to order on contract. Repairing for the trade in all its branches.

We sell to the legitimate Jewelry and Stationery trade only.



CHOICE PAPERS  
MAKERS OF  
**FINE STATIONERY**

For Correspondence, Wedding and Business Use, handsomely boxed, specially suited to the Jewelry Trade.

18 MURRAY STREET, NEW YORK.



# R. WALLACE & SONS MFG. CO.

SILVERSMITHS

Trade Mark.

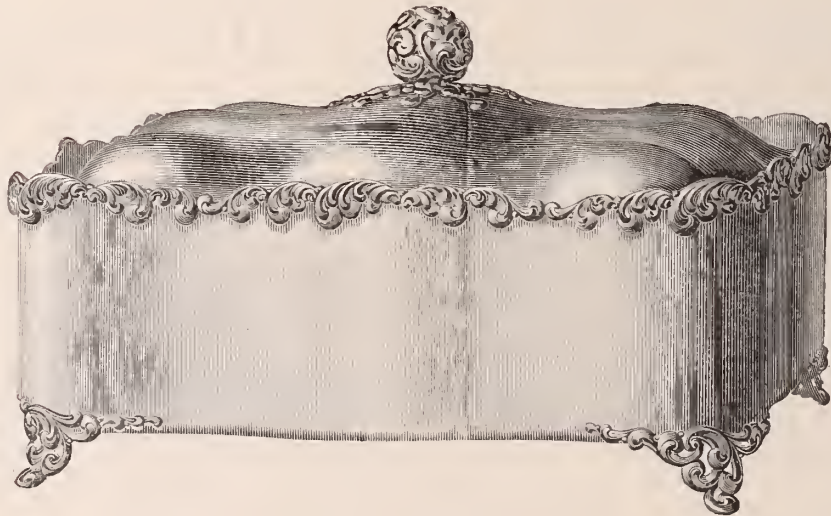

WAVERLEY SARDINE BOX.

Manufactories and  
Main Office,

WALLINGFORD, - - CONN.

BRANCHES :

NEW YORK  
3 PARK PLACE.

SAN FRANCISCO,  
120 SUTTER STREET.

CHICAGO  
86 WABASH AVENUE.



**The Appraisal of the Estate of the Late Isaac C. Lewis.**

MERIDEN, Conn., Feb. 23.—The appraisal of the estate of the late Isaac C. Lewis, ex-president of the Meriden Britannia Co., shows the value of all the property to be \$1,144,260.46, divided as follows:

Real estate.....	\$136,750 00
Stocks.....	604,362 00
Bonds.....	134,938 39
Notes, mortgages, etc.....	223,343 89
Bank deposits, etc.....	44,866 18

Total.....\$1,144,260 46

The bulk of the real estate is Meriden property, and the \$604,362 in stocks represents the interests of the estate in Meriden corporations as a rule. The bonds are generally those of municipalities for public improvements. Of the quarter million of dollars held in notes and mortgages, fully 90 per cent. are Meriden obligations. The last item shows the amounts on deposit in savings banks and elsewhere.

There are three heirs to the estate, viz: Mrs. J. H. Chapin, Mrs. C. H. Fales and Henry J. Lewis, of Stratford.

**Proposals for Furnishing Anemometer Registers.**

WASHINGTON, D. C., Feb. 23.—The War Department through the Signal Office, is inviting proposals until March 15th, for furnishing the signal service 10 anemometer registers, described in the following specifications: To be similar to the stop watch pattern of 1892, which is a guide but not a model. The clock movement to be the Seth Thomas chronometer lever No. 5003, or other pattern equally powerful and reliable for the purpose indicated, and the style, number and name of manufacturer must be stated in the proposal. The base and case to be of first quality brass; the workmanship in all essential respects to be in every way first class and superior to the present sample. The exterior case shall be considerably stronger, and the interior mechanism shall be mounted on a suitable, strong dial plate and the whole screwed in rigid manner to a substantial frame work.

The successful bidder shall make such alterations in the present system of mechanism as shall insure perfect action of the register, and, extraordinary breakages excepted, shall offer guarantee to the chief signal officer to keep said registers in good working order for the space of one year. Bids for the above are to be made in duplicate, and are to be addressed to the Disbursing Officer, Signal Service, War Department, Washington, D. C., and must be in his hands by 2 o'clock p. m., on the date above mentioned, at which time they will be opened in the presence of such bidders as may feel sufficiently interested in the contract to be in attendance.

It is expected that orders will be made on the accepted bidders for not less than one-fourth the estimated quantity. Upon the failure of any contractor to furnish any

# THE BOWDEN SEAMLESS RING

IS MADE ONLY BY

## J. B. BOWDEN & Co.,

Makers of Finger Rings of every Description.

COR. BROADWAY & JOHN STREET,  
NEW YORK.

## DIAMOND EXCHANGE BUILDING.



In the new fire proof, ten story

Diamond Exchange Building,

14 Maiden Lane.

### OFFICES

of most modern construction, with abundance of light and air, rapid elevator, mail chute, steam heat, gas and electric light, exposed sanitary plumbing, oak cabinet trim, unique plate glass partition and quartered oak floors, at rentals from

**\$900.00**

Per Annum up.

Specially adapted for the Diamond and Jewelry Trade. Possession on or before May 1st, next.

For further particulars apply to

**E. A. Cruikshank & Co.,**

176 Broadway, N. Y.

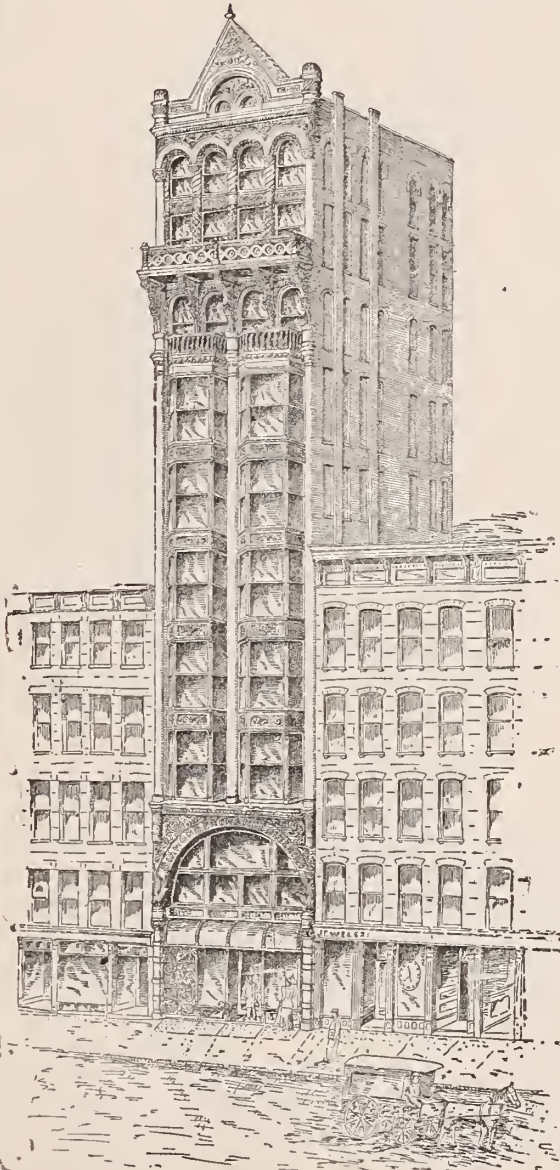

THE ELEVATOR IS NOW RUNNING.



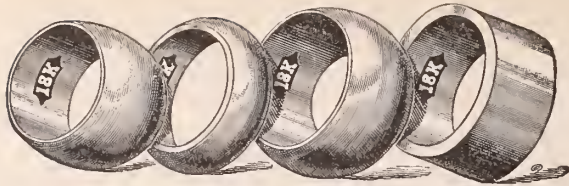

Band Rings metal lapped. Full value allowed for old gold.

**PLAIN SOLID GOLD RINGS.  
HILDRETH MFG. CO.,**

53 MAIDEN LANE,

NEW YORK.



SPECIAL SALESMAN OF

**WATCHES, DIAMONDS,**

Bric-a-Brac  
and Art Goods

FOR

Established Jewelers.

WRITE FOR PARTICULARS.

Communications Strictly Confidential.

References given in all parts of the United States from Retailers and Jobbers

**MATHEY BROS., MATHEZ & CO.,**

21 & 23 MAIDEN LANE, N. Y.  
BRASSUS, SWITZERLAND.

Manufacturers and Importers of  
Plain and Complicated  
WATCHES.

**SPLITS**

A SPECIALTY.

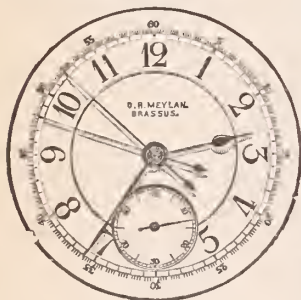

Sole Agents for

**Jaques Lecoultré Razors.**

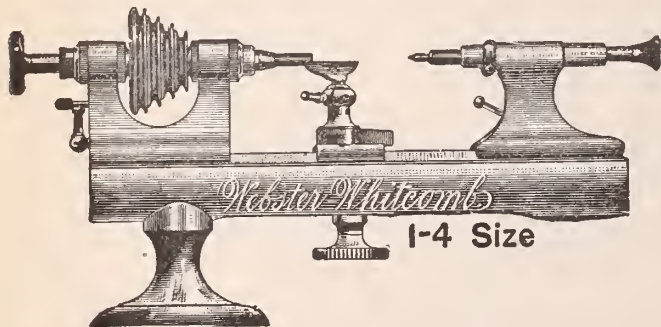

STRONGEST GUARANTEES.

Quality  
Maintained.  
Prices to  
Suit the Times.

Ask for our New  
Prices and  
Terms for 1894.

**American Watch Tool Company,**

Chymistry Dist., Waltham, Mass., Stoney Batter Works.

article or perform any service called for within a reasonable time after its being ordered, or upon his furnishing any article or work which fails to reach the standard, the office reserves the right to purchase or order in open market. If at any time, in case of purchasing or ordering in open market, a figure in excess of the contract price is paid for such articles or work so purchased or ordered, the difference will be charged to the contractor in default.

**The Affairs of Rosenstihl Bros.**

BIRMINGHAM, Ala., Feb. 21.—Rosenstihl Bros., who recently assigned, have opened up a jewelry repair shop at 111 N. 20th St. The assignment, as has been stated, was precipitated by an attachment on a rent contract. The many friends of this popular firm hope and believe they will soon be able to get their matters in such shape that they can resume business.

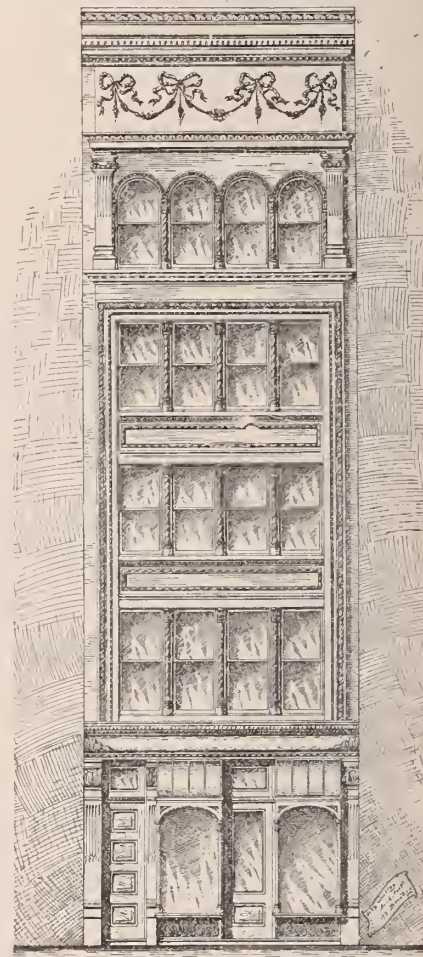

**TO LET**

IN THE

**HANDSOME NEW OFFICE BUILDING  
45 MAIDEN LANE,  
STORE 130 FEET DEEP.**

Excellent Light Throughout at Reasonable Rent, also OFFICES Light and Cheerful, with elevator, steam heat, electric light, best of plumbing and all modern conveniences, at rentals from \$350 up. For further particulars, apply to

**E. A. Cruikshank & Co..**

176 BROADWAY N. Y.



### Annual Meeting of the Pennsylvania Retail Jewelers' Association.

PHILADELPHIA, Pa., Feb. 23.—The Pennsylvania Retail Jewelers' Association of the National Retail Jewelers' Association, closed a very successful two days' convention here, last night. Many out-of-town people were present on Wednesday morning when business began at the local headquarters, 36 N. 9th St., among them being S. Reitzen, Hazelton, Pa.; Isaac Landis and D. Garman, Coatsville, Pa.; O. O. Stillman, New Brunswick, N. J.; S. Wildt, Alexandria, Va.; C. Solliday, New Hope, Pa.; E. Dougherty, Camden, N. J.; and J. S. Maree and William Bovard, Manayunk, Pa. The local representation was particularly strong, conspicuous members being Messrs. Forsythe, Hoffman, Herzberg, Bode, Pinkstone and Hamer. The entire attendance was close upon a hundred.

A general reception preceded business, the courtesies being performed by a committee headed by president Arthur S. Goodman; meanwhile secretary C. H. Hamer received and recorded numerous applications for membership. Dr. J. J. McGuigan, A.M., then delivered a lecture on practical electricity in its special relations to the working watchmaker. He was followed by D. V. Brown, who read an interesting essay, with practical illustrations, on the Weiland optimeter, together with its uses and advantages in saving time in examining the eye. After this there was a recess.

When the convention reassembled, superintendent E. A. Marsh, of the American Waltham Watch Co., engaged the attention of the convention. Among other things Mr. Marsh stated that up to the time they took "a national holiday" in June last they were making 2,100 watches a day. There were 150,000 in process of manufacture all the time. Now they would be glad to resume the business if the jewelers would buy the watches.

Mr. Marsh showed them pictures of the watchmaking machinery, which has abolished the watchmaker and put the mechanic in his place.

"And what, at this rate of going, will become of the watch repairer?" asked one man.

"He has the poorhouse ahead of him" was the reply, which produced more laughter.

Thursday's session began with an address by Willis B. Musser, on "The Methods Essential to Success in Business," after which President Goodman presented his annual report.

#### PRESIDENT'S REPORT.

Gentlemen of the Pennsylvania Retail Jewelers' Association:

Agreeable to the direction of our By-laws, I have the honor of placing before you my report as President of your Association for the fifth consecutive term: In reviewing the events of the past twelve months, as applied to the welfare of the association and its members, much could be said of the conditions that have made

the year an exceedingly depressing one for all who look to and are engaged in the jewelry business as a means of livelihood; in common with other industries of whatsoever nature, the association has to some extent at least felt the unprecedented stringencies of the past and present circumstances which are influencing the common prosperities of the trade. The shrinkage of general business during 1893 has greatly affected us as individuals; much more so, in fact, than as an association. As a body we have continued to hold our position, and while comparison with the preceding years shows that our growth has not been quite so rapid, as a whole we can, however, congratulate ourselves that the standing of the Pennsylvania Retail Jewelers' Association is unimpaired, and that it still holds its proud position among the leaders of our trade organizations. Its finances are in a healthy condition, every indebtedness of the year has been met, and the Treasury holds a fair balance. Its efforts in the cause for which we have united have at all times been persevering to the end we are looking forward to, the protection of our trade from detrimental and foreign influences.

During the period since my last report, several important matters have transpired, all of which have been met and dealt with in strict accordance with the policy of the association; due progress has been made in various directions, and at all times your executive officer has to the best of his ability been prompt and decisive in maintaining the best interests of the organization.

I am pleased to re-ord that the gentlemen selected at our last convention as delegates and alternates to the national body, faithfully attended to their duties and were present at the meetings in Chicago last July. They were prominent in the affairs and deliberations that took place, with all of which no doubt you are familiar; and I take this opportunity of expressing my sincere appreciation of their exertions for the good of the cause on that important occasion, feeling that our Association has nothing to regret in the wisdom that led to their prominence as representatives of Pennsylvania.

Your Journal Committee's report, when read, will convince you that the hard times have not interfered with the progress of the *National Retail Jeweler*; it continues to be, as originally intended, the standard bearer of our trade grievances, and as such recognized and supported by both the wholesale and retail trade, who have bestowed a liberal patronage, and to whom our thanks should be extended. The past year shows that valuable acquisitions have been made to the subscription lists, demonstrating the regard with which the craft, independent of organization, look upon it as deserving of their encouragement for its persistent work on behalf of better business methods, and demands for the considerations we are all entitled to as active retail jewelers. Some changes in the outward appearances of the journal are contemplated with the ending of the present volume, which will doubtless improve it; the details will be placed before your Board of Directors at the proper time for their consideration.

A special committee was recently appointed at a regular monthly meeting, who have prepared a written report of their purpose, to be acted upon at this session, in which they offer several changes in our present policy, and I would earnestly bespeak for the report your best attention. Personally I fully concur with their recommendations, feeling that their adoption will greatly add to our future success. The recommendations are the result of their observations and experience as active and enterprising members, and as such should have weight and call forth your favorable opinion and endorsement.

As an illustration of the growing respect now prominent towards organized retail jewelers generally, the recent visit of your president to New York, to speak before the National Association of Watch Jobbers, may be cited as an example; it was the first time that a personal and official remonstrance was made by retail jewelers, regarding the retailing done by some of their members, also the support they were giving either directly or otherwise to the very many schemes that are so unjust to the retail jewelers' interests, and exceedingly harmful to the trade in general; crowding thousands of honest jewelers from their lawful heritage, the result of many years' devotion to mastering the intricacies of their difficult avocation, and robbing them of the reward every tradesman expects—the

opportunity of making a living free from imposition and illegitimate ways of business. It is but fair to say that your president was listened to with attention, and received with respect; it was apparent that the National Association of Watch Jobbers were evidently willing to meet the retailer on common ground to discuss the problems about us, and with that object a committee was appointed by them to attend the National Convention in Cincinnati, in July. As this is likely to be a conspicuous feature of that meeting, it behoves our members to use care in the selection of delegates at this afternoon's session; those who will fitly represent Pennsylvania by virtue of their knowledge of the situation and experience as prominent jewelers.

Having about exhausted your patience with the length of this report, I will close with a few remarks that I feel are but just to those who have devoted a great deal of time to furthering the good of the organization; I refer to our officers and directors, upon whom the burden of the work falls, and it is with pride I look back over a period of five terms as your president, and can say that during the whole time mentioned, I have been more than seconded and assisted by the worthy officers and directors you have from time to time elected, and that nothing has ever occurred in the work for the cause, to produce even the slightest coolness between us and the cordial and friendly relations that have always existed among us since the Pennsylvania Retail Jewelers' Association was called into a useful life.

Gentlemen, I thank you for your kind attention.

The convention then went into executive session, when the following officers were elected to serve for the ensuing year: President, Arthur S. Goodman; vice-president, G. S. Katz; second vice-president, Asa Collier; treasurer, Isaac Herzberg; secretary, Charles H. Hamer; directors—J. R. Hamer, William H. Bovard, W. H. Dotter, S. L. Schumo, John Shulier, C. L. Conrad, F. C. Bode, Jr., George A. Bowen, S. C. Levy, Emil Holl, James G. Maree, R. Pinkstone, E. H. Williams, O. O. Stillman and J. B. Jansen.

S. C. Levy, I. Herzberg and R. Pinkstone were chosen as delegates to the National Convention at Cincinnati, in July, with Asa Collier, O. O. Stillman and G. S. Katz as alternates. The annual banquet was enjoyed at the Builders' Exchange Cafe, in the evening. President Goodman acted as toastmaster, and many impromptu toasts were responded to.

Preparations are being made to re-open the watch case factory of A. Haege, Union Hill, N. J. Haege & Schwartz will superintend the business. The factory employs 100 men.



**M. L. READ & CO.,**

161 DORRANCE ST.,

PROVIDENCE, R. I.

THE  
Old

Reliable

House

FOR  
STICK PINS AND

WHITE STONE GOODS



### A Daring Window Smasher Promptly Captured.

LOWELL, Mass., Feb. 21.—A daring robbery occurred this afternoon at 5:20 on Central St., where hundreds of persons were hurrying to and fro. On Central St., opposite the American House, is situated the jewelry store of G. H. & M. F. Wood. A tough character, named W. H. Bent, deliberately threw a 20-pound horse-weight through one of the 9 feet square plate glass windows and snatching a tray of 20 gold watches made off.

## EASTER SPOONS



As every year brings a greater demand for suitable gifts for Easter, we have originated an Easter Spoon which we believe will meet with a ready sale. Advertisements of this Spoon will appear in the *Century*, *Cosmopolitan* and *Churchman*.

The die is very deeply cut, making a Spoon of heavy weight (6 oz. to the dozen). We have made a very low price to the trade wishing to make it an object for you to handle these Spoons.

Egg Spoon, per doz., \$11.00  
 " " gold bowls,  
 7 per doz. .... 13.00  
 Coffee Spoon, same  
 handle, per doz. .... 10.50  
 Coffee Spoons, gold  
 bowls, per doz. .... 12.50  
 Terms—net 30 days; 3 per cent. 10 days.

These Spoons retail at \$1.25 with plain bowls and \$1.50 with gold bowls.

**Daniel Low,**  
 Salem, Mass.,

MAKER OF  
 The "Witch" Spoons.

Easter "EGG SPOON."

**WOOD & HUGHES,**  
 STERLING SILVERWARE MANUFACTURERS  
 New York Agents for the Derby Silver Co.'s  
 FINE QUADRUPLE PLATED WARE,  
 NO. 16 JOHN STREET, NEW YORK;  
 206 Kearney St., San Francisco, Cal.  
 HASKELL & MUEGGE, Agents.

He ran less than 300 yards when he was captured and handed over to the police. All the property was recovered.

### Watchmakers Get a Judgment Against the Trenton Watch Co.

TRENTON, N. J., Feb. 21.—Judge Chauncey Beasley yesterday morning filed a long opinion in the City District Court in the case of Edward G. Paine and Charles E. Stanley, who sued the Trenton Watch Co. for \$300 each for breach of contract. He orders judgment for each plaintiff for \$100. The case has become well-known, and is interesting the employers and employes. Details of the case were given in the last issue of THE CIRCULAR.

In concluding the opinion the Judge says:

In the case before the Court it will be seen that the plaintiffs when they came to Trenton and offered themselves ready and willing to perform their part were induced by the defendant company to remain in Trenton until the works opened. If the works had opened on August 1st and the plaintiffs had entered into the employ of the company, it cannot be doubted but that they could have been for a good cause discharged by the superintendent at any time; or if after they had entered the employ of the company and the works had shut down for any reason, they certainly could not recover for their wages for the time the works shut down. But here we find the superintendent, acting for the company, stating to the plaintiff that he will have plenty of work for them, telling them that the works will open at such and such a time, after having induced the plaintiffs to come from a great distance to enter their employ, now asking to be discharged from any liability to pay their wages during that time. I am of the opinion that the defendant company has broken its contract with the plaintiffs. The plaintiffs, therefore, are entitled to damages. I have had considerable difficulty to determine what should be the measure of damages in a case of this kind. There was no proof offered in the case as to what expenses the plaintiffs had been put to in coming from Canton, nor was there any testimony to show what expense they had been put to while out of work in Trenton. That the plaintiffs are entitled to some damages for the breach of this contract is in my mind quite clear. The natural damage arising will be the expense of coming to Trenton and going back to their home; the money expended for board while in Trenton, and finally damages for loss of time while in Trenton and reasonable damages for time lost in seeking other employment.

I at first was of the opinion that the measure of dam-

ages in this case would be the amount of wages that the plaintiffs would have made had they worked from August 1 to October 2, which was the date of the starting of the factory. But the contract is so indefinite that I hesitate to lay down this principle of law. If the time of the employment had been fixed I would have had no difficulty in this case; but it is left indefinite by both parties how long the hiring was to continue.

The plaintiffs were to start work August 1st, but nothing is said in the contract as to how long this work was to continue. I am sorry that a jury was not called in this case that they might fix the measure of damage, but, taking the whole case into consideration, I am satisfied that the better rule in cases of this kind would be to hold that the plaintiffs are entitled to such damages as will naturally result from the breaking of the contract sued upon. I estimate this damages at \$100 in each case. I might add that one of the defenses set up by the company was that the superintendent had no authority to make a contract of this kind; that he had no right to hire men and make the company liable for wages when the works were shut down, but the testimony is so clear upon this point that I do not think it worth commenting upon. Mr. Moreland swears that he had entire charge of hiring and discharging men. The directors swear they told him not to make any special contract. The rule of law is well settled that if a company hold a man out to the world as a general agent, that all acts done by him within the scope of his agency are binding upon the principal.

It will be absurd to say that this company having given secret instructions to their agent not to make contracts of this character, holding him up to the world as having complete charge of the hiring of men, the length of time hired, the amount of wages they are to receive, but the superintendent could not make a contract with a man to commence work at a certain time and to receive a certain amount of money.

### Returns From Providence Corporations.

PROVIDENCE, R. I., Feb. 26.—In accordance with the requirements of the law in this State the following corporations have rendered their yearly statement to the General Assembly:

William T. Smith Mfg. Co.:—Capital stock Dec. 30, 1893, \$100,000; personal assets, including treasury stock valued at \$9,000, \$132,131.41; liabilities, \$32,131.41.

Burdon Seamless Filled Wire Co.:—Capital stock paid in Dec. 31, 1893, cash, \$84,700; patents, \$60,000, total \$144,700; value of real estate, \$60,600; personal assets (including treasury stock of par value of \$105,300), \$400,351.99; liabilities, \$134,312.97.

Barker Mfg. Co.:—Capital stock Jan. 31, 1894, \$20,000; assets, including 120 shares of capital stock valued at \$6,000, \$21,102.53; liabilities, including capital stock, \$21,102.53.

Nicholson File Co.:—Capital stock paid in December 31, 1893, \$500,000; value of real estate in Providence, \$132,200, in Lincoln, \$42,000; personal assets in Providence, \$262,480.32, in Lincoln, \$92,204.46; liabilities \$60,000.

Howard Sterling Co.:—Capital stock paid in December 31, 1893, \$235,800; personal assets, \$322,179.39; liabilities \$82,060.07.

J. B. & S. M. Knowles Co.:—Capital stock paid in December 31, 1893, \$54,000; assets \$86,395.95; liabilities \$23,971.48.

American Enamel Co.:—Capital stock paid in December 31, 1893, \$50,000; value of real estate \$15,780; personal assets \$42,261.97; liabilities \$26,312.29.

## FINE CHAMOIS SKINS.

BEST & CHEAPEST IN THE MARKET.

By the Kip or in Small Quantities.

MANUFACTURED BY

**GEO. H. TAYLOR.**

GEORGE C. TAYLOR, Agent.  
 HAVEMEYER BUILDING,  
 26 CORTLANDT STREET, N. Y.

**CHRYSO-CERAMICS,**  
 GOLD COVERED PORCELAIN.  
**M. & E. HEALEY,**  
 1122 CONNECTICUT AVE., WASHINGTON, D. C.  
 MEDAL AT WORLD'S COLUMBIAN EXPOSITION.



**The Jewelers' Relief Association Performing Good Work.**

Applications for relief still continue to pour in to the Jewelers' Relief Association. The persons who have been assisted now number in the thousands. Repeated relief has been given in many instances where the applicants have been unable to get work, and this circumstance with the constant increase of cases of distress has eaten up a large part of the relief fund. A great many calls have been lately received for overcoats and shoes, which have been purchased from societies with which the Jewelers' Relief Association co operates.

Max J. Lissauer, president of the Jewelers' Relief Association, acknowledges receipt of the following additional subscriptions:

Unknown, through Enos Richardson & Co....	\$450.87
Elgin National Watch Co.....	100.00
F. Ecaubert.....	50.00
Julius King Optical Co.....	25.00
J. T. Scott & Co.....	25.00
Ostby & Barton Co.....	25.00
T. G. Brown's Sons.....	25.00
W. S. Hic's Sons.....	20.00
Treibs Bros.....	10.00
R. S. Ferguson.....	10.00
R. Blackinton & Co.....	10.00

\$750.87

Previously acknowledged ..... \$5,655.26

Total ..... \$6,606.13

Further donations should be sent to A. J. G. Hodenpyl, treasurer, 170 Broadway, New York.

**The Schedules of Simon Dessau.**

The schedules of Simon Dessau, 4 John St., New York, were filed with the clerk of the Court of Common Pleas Saturday. They show direct liabilities of \$321,915, contingent liabilities of \$67,297, nominal assets of \$669,077, and actual assets of \$14,384. The great difference in the assets, it was stated, is because the real estate is mortgaged for all it is worth, and that many accounts are uncollectible. The real estate consists of 762 to 766 Broadway, leasehold, valued at \$175,000; 756 to 760 Broadway, leasehold, \$75,000; 749 and 751 Broadway, leasehold, \$155,000; 140 E. 79th St., \$33,000; 154 E. 80th St., \$30,000.

The following are the principal creditors, some of whom are secured by mortgages: Hyman Israel, \$10,000 and \$8,000; Hyman Israel's Sons, \$4,250; Andrews & Doty, \$12,750 and \$11,775; M. J. Lichenberg, \$4,013 and \$4,075; Proctor Trust Co., \$2,000; M. A. Magnus, \$1,910; Market & Fulton National Bank, \$6,117; Butchers' & Drovers' Bank, \$10,400; E. D. Garnsey, \$12,141 and \$6,700; A. B. See & Co., \$2,000; Receiver of taxes \$58.60; Mrs. Sophia Dessau, \$23,605; Amelia Dessau, \$2,239; David Dessau, \$2,239; Morris Dessau, \$2,239; Estate Jos. Jessurin, \$6,572; Trustees Sailors' Snug Harbor, \$15,000 and \$7,437; Marks Rinaldo, \$20,000; Gussie Buckley, \$2,000; J. D. Buckley, \$23,000; W. T. Day, \$3,500; M. J. Radway, \$20,000; Henry Weil, \$60,000; U. S. Life Insurance Co.,

\$19,000; Simon May, \$4,000; J. Geiber, \$6,000; Chaley, Monnier & Challey, \$21,000; V. Bishop & Co., \$4,384; Hyman Israel's & Sons, \$8,600; H. Folkart, \$3,800; N. Y. Guarantee & Indemnity Co., \$5,700, and Manhattan Life Insurance Co., \$1,900.

The assignee's bond was fixed at \$100,000.

**Some Further Particulars of the Failure of A. R. Brooks Jewelry Co.**

ST. LOUIS, Mo., Feb. 22.—The A. R. Brooks Jewelry Co., 417 N. 4th St., who assigned Feb. 19th to the St Louis Trust Co. in trust for creditors, as reported in last week's CIRCULAR, have assets consisting of a stock of watches, clocks, silverware, etc., all valued at \$25,000. Theodore Rassieur attorney for the assignee, who drew the papers, said, when seen, that he had very little knowledge of the condition of the firm beyond the understanding that the assets were from \$25,000 to \$30,000, while the liabilities might be in the neighborhood of \$35,000.

Mr. Rassieur said that the A. R. Brooks Jewelry Co. were organized some years ago by A. R. Brooks, who had been a member of Brooks Bros. & Co. Their capital was \$15,000. When Brooks Bros. & Co. failed last Fall some of the eastern creditors got the idea that the A. R. Brooks Jewelry Co. might be involved and began to press the concern for their money. As the Winter tightness in the trade drew on, the pressure increased, until the company were threatened with suits, and attachments were hinted, and finally A. R. Brooks determined on an assignment as the only way to protect all the creditors.

**Sebastian Andersen Dies Suddenly of Apoplexy.**

CHICAGO, Ill., Feb. 26.—Sebastian Andersen, of the Juergens & Andersen Co., died suddenly at 11 o'clock, Sunday night, of apoplexy. Mr. Andersen was in his usual health on retiring at 10 o'clock. An hour later Mrs. Andersen was awakened by what she thought was her husband snoring, but which proved to be the death rattle. Physicians were summoned but Mr. Andersen was past relief.

Deceased was born in Germany, Aug. 2, 1828. He went to New York in 1854, and entered into business in Chicago with Paul Juergens in 1857, taking an active part in the management until his death. He had many years of active usefulness before him and his sudden death is deeply deplored.

Mr. Andersen leaves a widow and two sons, Julius P., and William G., the latter a member of the jewelry firm. The funeral will occur from the residence at 11 o'clock Wednesday, the remains being interred at Graceland. The factory will be closed the first three days of the week.

**The Death of A. E. Crosby.**

HOLYOKE, Mass., Feb. 23.—A. E. Crosby died yesterday morning at his home at 411 Main St. He had been ill for about two months. He leaves a widow and a daughter. He had lived in Holyoke about 20 years, and was an overseer in the mill of the Springfield Blanket Co. He was also proprietor of a jewelry store at 409 Main St. The firm also sold hardware under the name of Crosby & Wells.

# CHARMILLES

(PRONOUNCED SHAR-MEAL)

is the name of a new **HIGH GRADE, LOW PRICE WATCH** constructed on an entirely new and novel plan and which is now being put on the market through the jobbing trade, and will be extensively advertised to the trade and general public.

**IT IS SURE TO BE A WINNER,**

as it possesses greater merit than any watch made for the money.

. . . **ASK YOUR JOBBER FOR THEM** . . .

**A Full Line  
OF ALL  
AMERICAN  
WATCHES.**

**MAX FREUND & CO.,**  
Importers of **Diamonds and Precious Stones,**  
**AMSTERDAM: 8 MAIDEN LANE,  
TULPSTRAAT 9. NEW YORK.**

**SPECIALTY:  
DIAMOND  
JEWELRY**  
of our own design.



# Sterling \* Silver \* Belts.

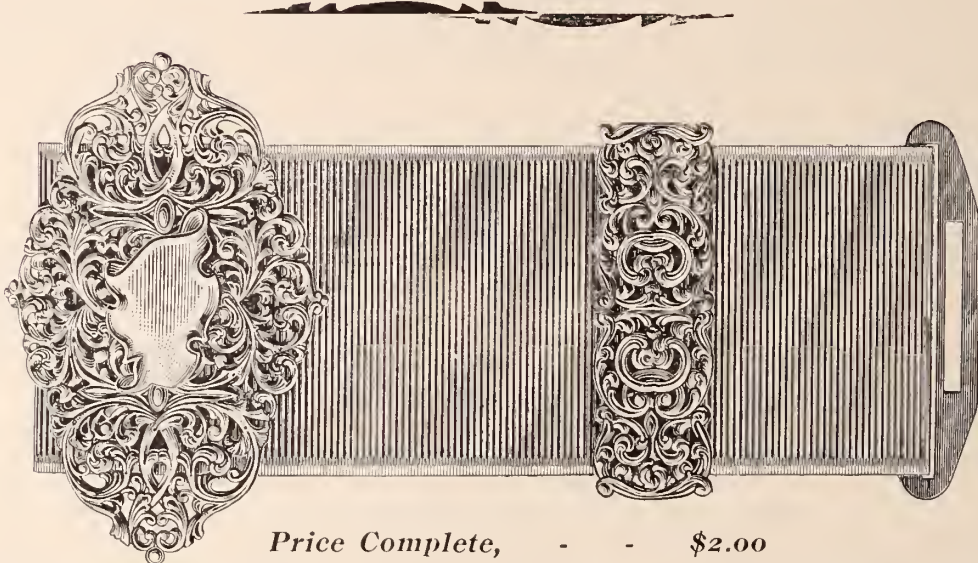

Price Complete, - - \$2.00

WE WERE THE ORIGINATORS OF THIS STYLE OF BELTS AND WE PROPOSE  
TO HOLD THE TRADE ON THEM.

We claim that our line of Belts (60 different patterns, all bright cut) are original and artistic in design and of best workmanship and finish, and we guarantee them to be much cheaper than any Sterling Silver Belts made.

The Buckles are mounted on the Finest Quality of Webbing, which we guarantee to be all Silk (no cotton filling) and full 20 line ( $\frac{3}{4}$  in.) wide, and we are pleased to announce that from this date we are prepared to fill orders for any of our regular shades of Webbing with the MOIRE ANTIQUE finish as shown in illustration, without extra charge.

We Lead==Others Try to Follow.

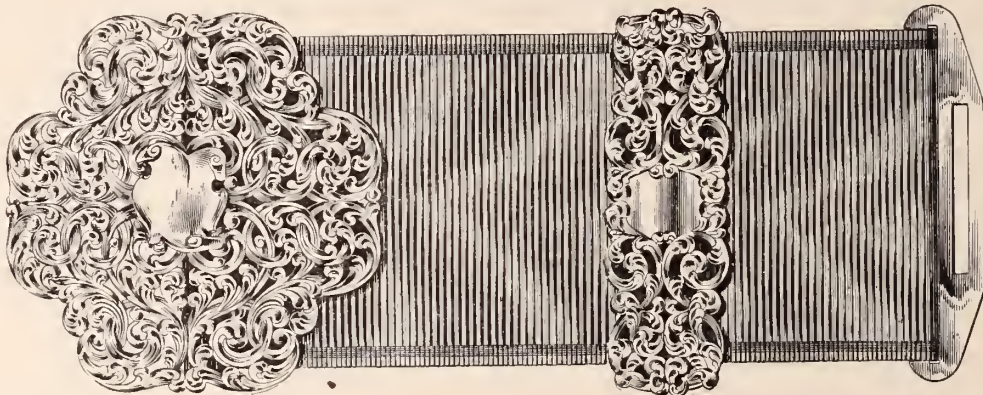

Price Complete, - - \$1.75

## UNGER BROS.,

.... MAKERS OF ....

Fine Jewelry in 14k. Gold and Sterling Silver, .925 Fine,

.... AT SALABLE PRICES ....

192 Broadway, = New York.



# The Jewelers' Circular

AND  
HOROLOGICAL REVIEW.

PUBLISHED EVERY WEDNESDAY BY

THE JEWELERS' CIRCULAR PUB'G CO.,  
189 BROADWAY, NEW YORK CITY.

A JOURNAL DEVOTED TO THE INTERESTS OF JEWELERS, WATCHMAKERS, SILVERSMITHS, ELECTRO-PLATE MANUFACTURERS, AND ALL ENGAGED IN KINDRED BRANCHES OF INDUSTRY.

Our Editorial columns will contain our own opinions only, and we shall present in other columns only what we consider of interest or value to our readers. Advertising matter will not be printed as news.

Advertising rates in THE CIRCULAR are lower, considering the number of tradesmen reached by its large circulation, than in any other jewelry journal.

Notices of changes in standing advertisements must be received one week in advance; new matter can be received up to Monday.

## INFORMATION FOR SUBSCRIBERS.

### Terms of Subscription, Postage Prepaid.

	PER ANNUM
United States and Canada, - - -	\$2.00
Foreign Countries in Postal Union, - - -	4.00
Single Copies, - - - - -	.10

New subscribers can commence at any time.

Payments for THE CIRCULAR, when sent by mail, should be made in a Post Office Money Order, Bank Check or Draft, or an Express Money Order or Registered Letter. All postmasters are required to register letters whenever requested to do so.

Pay money only to authorized collectors having proper credentials.

Returning your paper will not enable us to discontinue it, as we cannot find your name on our books unless your address is given.

In changing address always give the old as well as new one. Your name cannot be found on our books unless this is done.

We will continue to send papers until there is a specific order to stop, in connection with which all arrearages must be paid; but such an order can be given at any time, to take effect at the expiration of the subscription. All such orders will be promptly acknowledged by mail.

The Courts have decided that all subscribers to journals are responsible until arrearages are paid in full and an order to discontinue has been received by the publisher.

Member of the American Trade Press Association.

Vol. XXVIII. Feb. 28, 1894. No. 4.

### Fresh Water Pearls.

THE United States Commission of Fish and Fisheries is seeking definite information regarding

the fresh water pearl fisheries of the country. George F. Kunz has been intrusted with the matter, and he has prepared a circular of inquiries submitting 30 questions, which is reproduced in another portion of THE CIRCULAR. The investigation will add appreciably to the wealth of the country by indicating where mussels are likely to be found, and by describing the best means of fishing and extracting the pearls. Every reader of THE CIRCULAR who is capable of furnishing any information sought should promptly communicate with Mr. Kunz.

### Charity

### Among Jewelers.

WHILE the organization of the Jewelers' Relief Association, of New York, was generally applauded, and while many firms and persons have loosened their purse strings to assist the association in the performance

## Spanish-American Edition of The Jewelers' Circular.

In our opinion, the tariff agitation, notwithstanding the changes that may be effected in the Wilson Bill by the Senate, will make it necessary for our manufacturers to seek a more extensive trade than they have heretofore possessed. The export field offers this opportunity. We all recognize the countries of Mexico, Central America, Cuba and South America to be a most desirable field for American manufactures.

With a view to bringing the productions in the lines represented by THE CIRCULAR more prominently before the dealers in jewelry, etc., in these countries, we will issue between the dates of March 15th and April 1st, an Export Edition of THE JEWELERS' CIRCULAR for circulation in the above countries, including all the jewelers of Mexico, Central America, Cuba and some of the large cities in South America.

This edition will be printed, both advertisements and reading matter, in pure Spanish, and will be finely illustrated. If you desire space in this number please communicate with us at once and rates will be made known upon application. Copy for advertisements is to be sent to us in English, which we will properly translate into Spanish.

Yours truly,

The Jewelers' Circular Publishing Co.

of its good work, there still remain many who seem to be callous to the cry of the distressed. New York is not uncharitable, and its jewelers particularly not so. However, when we remember that the Chicago jewelers rapidly obtained the sum deemed necessary to devote to charitable purposes, and that the New York Jewelers' Relief Association in over a month has not obtained within several thousands the sum needed, we are apt to infer that the Garden City is the metropolis of the country in one great regard at least. Hump thyself, oh! backward jeweler, be thou retailer, manufacturer or jobber, and give thy pittance, let it be never so small, so long as it be the largest in thy ability and be given with good grace.

### Art in

### Window Dressing.

OBSERVERS have remarked within the past five years a notable improvement in the character of the window displays of the retail jewelers, both in the large cities and in the towns and villages. This interest in window dressing has been particularly prominent in its manifestations during the past two years. This period has been concurrent with THE CIRCULAR's publication of the series of Suggestions for Window Decoration, and we are not really lauding ourselves when we assert that this series has achieved its aim, namely: to arouse a general spirit of emulation among jewelers in respect to their window displays. The series this week offers its 67th suggestion, which means that 66 valuable illustrated ideas have already appeared under the department. Each suggestion has contained some element of beauty, uniqueness or attractiveness, besides being thoroughly practical, as they were illustra-

tions of real windows described and delineated, more or less accurately, by the jewelers themselves. The proper conduction of this department is exacting and arduous, but it is gratifying to know that it is thoroughly appreciated by the trade.

## The Week in Brief.

THE inventory of the estate of the late Leroy B. Haff, New York, was filed—C. C. Magruder, an alleged pepper thrower, was captured in Hot Springs, Ark.—A contest took place in the courts for the possession of the store of Hugo Marcus, New York—Isaac Weiner, Portland, Conn., supposed to be missing, was arrested—A bill is before the Kentucky Legislature to raise the license of itinerant vendors of merchandise—The appraisal of the estate of the late Isaac C. Lewis, Meriden, Conn., was made known—The annual meeting of the Pennsylvania Retail Jewelers' Association was held in Philadelphia, Pa.—The death occurred of C. Aug. Calame, St. Louis, Mo.—The death occurred of Sebastian Andersen, Juegens & Andersen Co., Chicago, Ill.—The widow of G. H. & M. F. Wood, Lowell, Mass., was smashed—A judgment was given against the Trenton Watch Co., in favor of two employes—The death occurred of A. E. Crosby, Holyoke, Mass.—A meeting of the creditors of Edmund Eaves & Co., Montreal, Que., is to be held—The judgment creditors of the Philadelphia Optical & Watch Co. have appealed against the decision of Judge Finletter—The death occurred of Joseph C. Knowles, Providence, R. I.—E. C. Cole's store, Drummondville, Ont., was burglarized.



### New York Notes.

Max Panino has entered a judgment for \$221.88 against Morris and Katie Barit.

Jos. Frankel's Sons have entered a judgment for \$785.87 against Moses J. Lichtenberg.

Mr. and Mrs. Sig. Hirschberg have returned from New Orleans, La., after a three weeks' pleasure trip.

Chas. F. Wood and Elmer E. Wood, of Chas. F. Wood & Co., sail for Europe Wednesday on the *Majestic*.

Anna Heinecke, 30 E. 125th St., has given a chattel mortgage for \$600 on jewelry fixtures to C. Vogel.

A judgment for \$586.74 has been entered against Abraham J. and Morris Groenman in favor of J. Wertheimer.

Levin & Wallenstein will remove May 1st from 479 Broadway to the Cable building, Broadway and Houston St.

N. Barra, Union Ave., Brooklyn, has given a chattel mortgage on his jewelry store to M. Rubbo for \$800.

W. F. and M. H. Duryea, 194 Broadway, have given a chattel mortgage for \$1,000 on jewelry fixtures to E. Duryea.

Richard Shaller, West Hoboken, N. J., has given a chattel mortgage on his jewelry business to F. orien Blier for \$400.

The stock in the jewelry store of Jno. W. Day, 199 Fulton St., Brooklyn, was considerably damaged by water last week, by the bursting of a frozen leader on the building.

I. Michelson & Co. have obtained a judgment against W. G. Smith, Youngstown, O., for \$72.09. The debtor has given bail for a stay of execution, which expires Aug. 30, 1894.

Wortz & Voorhes will soon open their quarters in the Bradley building, 18th St. and Fourth Ave. This firm, recently started, will manufacture solid gold and silver jewelry and novelties.

The sheriff last week took possession of the jewelry store of Nathan Frank, 26 Bowery, on an execution for \$458.38 in favor of Henry Moss, and another for \$217 in favor of Samuel Aronson.

A. A. Roy has given a bill of sale of the jewelry fixtures of the store at 258½ Eighth Ave. to E. R. Gratz for \$125, and another on the fixtures of his store at 106 Eighth Ave. to H. A. Hovet for \$566.

The explosion of an alcohol lamp in David H. Greenbergh's jewelry store, 599 Fifth Ave., Brooklyn, Friday afternoon, caused a fire that consumed \$4,000 worth of stock. The loss is covered by insurance.

In the suit of Mary J. Radway against Simon Dessau, Judge Freedman of the Superior Court Saturday appointed Geo. C. Guion, receiver of the rents, profits, etc., of the property owned by Mrs. Dessau at Broadway and 8th St.

Wm. I. Rosenfeld will remove May 1st from his present quarters at 34 Maiden Lane into those which will be vacated by Morris Prager, 8 Maiden Lane. Mr. Rosenfeld is

now on a trip through Connecticut, Rhode Island and Massachusetts.

A sale of smuggled jewelry took place at the United States Marshal's office in the Post Office building, Saturday afternoon. The goods consisted of a quantity of hair and hat pins, watch chains, bracelets, rings and hat ornaments of the cheapest quality.

Ed. E. Strauss, of Jacob Strauss & Sons, 53 Maiden Lane, was stopping at the Bendella House, Laurens, S. C., when that hotel took fire on Feb. 19th. Half dressed he escaped with his trunk and has since been ill from the effects of the excitement and exposure.

A fire broke out, Friday morning, in the sub-cellar of 4 Maiden Lane, used by the Julius King Optical Co. whose office is on the ground floor of that building. The fire was extinguished before the fire engines arrived, and did not do damage to any extent.

The Empire Specialty Co. have been incorporated with a capital stock of \$12,500. The company will deal in jewelry and fancy metal goods and have their principal office in this city. The promoters are: Samuel Harris, Jno. McNulty and H. V. Gavigan, all of New York.

A citation has issued to all persons interested in the assigned estate of Jacob N. Bonnet requiring them to appear in the Court of Common Pleas, April 5th, and show cause why the final settlement of the accounts of Philip E. Robinson, the assignee, should not be had.

Leon Sichel, brother of Simon Sichel, of Eichberg & Co., has started in business at 39 Maiden Lane as an importer of watches, jewelry and precious stones. Mr. Sichel is known to the trade, having been formerly with Keller & Untermeyer and the American Watch Case Co.

Morris M. Goldsmith, the father of Frederick and Ingomar Goldsmith, died at the residence of his son, Frederick Goldsmith, 57 W. 96th St., Saturday. He was 70 years old and had been suffering from pneumonia. The funeral took place Monday, and the office of Herzog, Goldsmith & Frank was closed that day in consequence.

Brewster Kissam, attorney for T. W. Adams & Co., 14 John St., stated Saturday that the firm will lose nothing by the indiscretions of their former salesman, Jno. R. Scofield, referred to in last week's CIRCULAR, as the matter had been settled satisfactorily to all parties, and the misappropriated goods had been recovered.

Paul Laval, well-known to the New York trade, who has been in Mexico for the past seven years, as watch inspector for the Mexican Central Railroad, has returned to this city and established himself at 59 Nassau St., as repairer of fine watches and chronometers. The Laval watch made by Mr. Laval and his father before him, was favorably known to the trade for many years after its introduction in 1848. It is no longer made.

On the complaint of Flora Carmichael, of 418 W. 16th St., Alfred A. Roy, a jeweler of

258½ Eighth Ave., was a prisoner in Jefferson Market Court Friday. On Nov. 30th Mr. Roy's store was robbed of a number of goods among which was a \$35 watch belonging to Miss Carmichael. Roy gave her another watch but Miss Carmichael contended that she ought to have \$35 turned over to her, and had Roy arrested. Justice Ryan held the jeweler for final examination to-day.

Mrs. Gertrude Phillips, the wife of Harry Phillips, was to have been examined Saturday before referee Meyer J. Stern, in the supplementary proceedings instituted against her husband by James Drew, who holds a judgment against him for \$1,054, for jewelry obtained under false pretenses. Mrs. Phillips failed to appear and sent a doctor's certificate stating she was suffering from nervous prostration. A motion will probably be made this week to punish her for contempt and for an attachment against her person to compel her to attend.

Judge Wheeler, of the United States Circuit Court, in an opinion filed Feb. 20th, has denied the motion for a re-hearing in the case of Wm. Mack vs. Levy, Dreyfus & Co. This suit which was brought in reference to an opera glass holder patented by Judge Mack, was recently decided in the plaintiff's favor. It was the second suit between the parties, and the motion denied was one made for a re-hearing upon the conclusiveness of the decree in the first suit which was also decided in the plaintiff's favor, but upon claims different from those at issue in the last action.

Lyonce Langer, formerly a diamond cutter, at 61 Nassau St., was the subject of a motion in the Superior Court last week. Some time ago, Robert L. Turk was appointed receiver for Langer in supplementary proceedings on a judgment of \$2,577 held by Jacob Rauth. Several creditors requested the receiver to sue Langer and his wife, Jennie, to set aside a deed executed by them conveying No. 251 Lexington Ave. to a Mrs. Stone, who conveyed it to Mrs. Langer. It is charged that this was done to cheat and defraud creditors. Judge Freedman, of the Superior Court, on Wednesday authorized the receiver to bring such a suit.

Judge Lawrence, of the Supreme Court, Monday, in the case of S. F. Myers & Co., and Ludwig and Julia Hess, handed down his decision on the motion of the defendants for an order opening their default and asking that the sheriff's sale of their stock upon the execution held by Myers & Co. be stayed. Judge Lawrence says: "The default in this case will be opened and the defendants allowed to come in and answer on the following terms: First. That the defendants pay the costs and disbursements of the plaintiffs up to the present time, including costs of motion. Second. That the judgment heretofore entered stand as security. Third. Defendants to have twenty days in which to answer the complaint and short notice of trial for the April term to be accepted."



**The Inventory of the Estate of the Late Leroy B. Huff.**

An inventory of the personal estate of the late Leroy B. Huff, of Dominick & Huff, New York, was filed in the Bergen County Surrogate's office, at Hackensack, N. J., last week. Mr. Huff was a resident of Englewood, N. J., although the great bulk of his property is in New York, and it is believed to be nearly all personal, excepting his home at Englewood. The will under which the division will be made was executed in October, 1880, and has been admitted to probate in New York and Hackensack. Mr. Huff was a bachelor, who lived from boyhood with an aunt, Mrs. Mary Barber. When Mr. Huff made his will he bequeathed one-half of it to his aunt, making special provision that, in case that share should not equal, or exceed, \$10,000, she should receive at least that sum. The other one-half is to go in equal shares to Mr. Huff's brothers and sisters, who are described as follows: Frank S. Huff, Frankfort, Ky.; Ralph Huff, Harriet G. Huff, Luella H. Huff, Anna M. Huff, all of Peru, N. Y.; Delia B. Sanderson, Holyoke, Mass.; Emma A. Adams, Newburyport, Mass.; Helen M. Belden, East Whitely, Mass.; Julia A. Smith, Saratoga, N. Y.; Sylvia G. Knowles, Bloomingdale, N. Y.

Mrs. Barber is to have the use of the personal effects of the dead man during her lifetime, if she wishes; otherwise they are to be divided among his brothers and sisters.

All other property is to be sold as soon as possible and the proceeds divided as indicated. The inventory developed somewhat of a surprise to all save the few intimately acquainted with Mr. Huff's affairs, as it foots up \$427,032.05, which is only the personal estate. The value of his realty cannot be learned at present.

The inventory bears the signatures of Donald Mackay, of the Stock Exchange, and William L. Bigelow, a lawyer, as appraisers. The principal item is 1.075 shares of the Dominick & Huff stock, par \$100, inventoried at \$175, or a total of \$188,125. There is also nearly \$40,000 cash and a large amount in railroad bonds. The estate is subject to a 5 per cent. inheritance tax in New Jersey and New York. H. B. Dominick and L. B. Bunnell are the executors.

**Much Ado About a Bill of Sale.**

Hugo Marcus, jeweler, was a prisoner in the Morrisania Police Court, New York, Wednesday, charged with burglary, preferred by Chas. Umfried. Until two months ago Hugo Marcus kept a jewelry store at 2659 Third Ave. His wife ran away just after Christmas, taking with her nearly all his property. After his wife disappeared Marcus set out to find her. He left his store in care of Umfried and gave him a bill of sale, so that creditors would not annoy him.

When Marcus returned, Umfried refused to give up the store, claiming that the bill of sale was legal. They quarrelled and

Marcus was arrested, but was discharged. After the decision of the court Marcus hurried away, going immediately to the jewelry store. When Umfried reached there he found the front door locked and Marcus in possession. He called a policeman and had Marcus arrested again, this time on a charge of burglary. When the case was called, Justice Burke discharged Marcus.

Umfried last week gave a bill of sale to A. B. Seaton for \$135 and the stock was removed from the store. Friedman & Ascheim, 51 Maiden Lane, who are creditors of Marcus, through their attorney Samuel Strasburger, Friday recovered a large part of the goods on an attachment for \$97.21. Mr. Strasburger stated that the bill of sale held by Umfried was worthless, as Mr. Marcus had signed it thinking it a power of attorney and no consideration was given. The proceedings of his clients, he said, protected the other creditors and Marcus.

**A Desperate Pepper Thrower Thought to be Captured.**

HOT SPRINGS, Ark., Feb. 22.—The police succeeded in arresting C. C. Magruder, charged with being the principal in the Dowling diamond robbery which took place in New Orleans on Jan. 20th, in which the thieves threw pepper into the eyes of the proprietor. Magruder was located, when arrested, in the Arlington Hotel. A search of his room failed to bring any of the stolen goods to light. He has been released.

**L. TANNENBAUM & CO.,**

IMPORTERS AND CUTTERS OF

**DIAMONDS • AND • PRECIOUS • STONES,**

Cor. Maiden Lane & Nassau St.,

NEW YORK.

25 HATTON GARDEN,  
LONDON.

TELEPHONE,  
Long Distance,  
1959 CORTLANDT

IN ORDER TO REDUCE OUR ENORMOUS STOCK WE OFFER THIS WEEK AT SPECIAL PRICES, THE FOLLOWING GOODS :

Rough Siam Rubies for cutting purposes, at 50c. per karat.  
Rough Fancy Sapphires for cutting, at 25c. per karat.  
Rough Sapphires for mechanical use, and precious stones for collections.

We also offer at special prices, the following goods :

**SAPPHIRES.**

8-61 1 Alexanderite Sapphire, 9 kt. 50, . . . at \$20.00 p. kt.  
19-408 1 Ceylon Sapphire (red at night), 6 kt. 43, at 18.00 "  
7-605 1 Sapphire, 4 kt. less 64m, . . . at 18.00 "  
13-314 1 Ceylon Sapphire, 14 kt. 22, . . . at 7.00 "  
3-407 13 Ceylon Sapphires, 27 kt. 11, . . . at 5.00 "  
24-381 6 " " 17 kt. less 1, . . . at 4.00 "  
3-450 41 Sapphires, 26 kt. 18, . . . at 16.00 "  
12-579 4 " " 6 kt. 6, . . . at 45.00 "  
24-409 3 Star Sapphires, 15 kt. 12, . . . at 15.00 "  
36-123 84 Pink Sapphires, 30 kt. 10 . . . at 4.00 "  
20-408 22 Fancy Sapphires, 25 kt. 9, . . . at 1.50 "

**EMERALDS.**

30-279 1 Emerald, 2 kt. 5, . . . at \$6.00 p. kt.  
31-278 1 " 7 1/8 kt., . . . at 7.00 "  
33-278 1 " 6 3/4 kt., . . . at 8.00 "  
22-794 71 Emeralds, 23 kt. 5, . . . at 7.00 "

**RUBIES.**

B-8-277 1 Ceylon Ruby, 1 kt. 46, . . . at \$25.00 p. kt.  
11-650 1 Ruby, 1 kt. 31, . . . at 15.00 "  
7-594 1 " 1 kt. 7 1/2 less 16m., . . . at 25.00 "  
27-533 42 " 15 3-16 kt., . . . at 7.00 "  
2-418 Small Oriental Rubies, 96 3/4 kt., . . . at 6.00 "  
33-552 12 Oriental Rubies, 7 3/4 kt., . . . at 25.00 "  
2-400 5 Star Rubies, 6 kt. 9, . . . at 30.00 "

**CATSEYES.**

15-349 16 Catseyes, 4 kt. 41, . . . at \$30.00 p. kt.  
47-397 16 " 13 kt. 10, . . . at 7.00 "

**SPINELS.**

3-376 21 Fine Spinels, 15 kt. 46, . . . at \$15.00 p. kt.  
395 50 " " 30 kt. 26, . . . at 25.00 "

**OPALS.**

3-555 1 Opal, 5 3/4 kt., . . . at \$18.00 p. kt.  
1-327 1 " 2 kt. 39, . . . at 15.00 "  
1-273 1 " 4 1/2 3-64, . . . at 18.00 "

**FANCY STONES.**

5-407 37 Fancy Stones, 59 kt. 23, . . . at \$3.00 p. kt.  
2-303 16 Chrysoberyls, 17 1/4 kt., . . . at 2.00 "



### Providence.

Philip and Andrew Linton and wives were present at the consecration of Bishop Tierney, at Hartford, on the 22d inst.

George C. McCormick has the sympathy of a host of friends in the death, on the 19th inst., of his only daughter, Isabel, one year, three months old.

John P. Brady, a jeweler, 20 years old, of 392 Wickenden St., died suddenly at his home at 2.30 o'clock last Tuesday morning. His death was the result of natural causes.

Edward S. Kent has transferred the valuable real estate tract bounded by Aborn, Beverly, Sabin and Mason Streets, whereon their new factory building is being erected, to the Kent & Stanley Co.

At the Prohibitory primaries in this city on Monday last, among the delegates elected to the General Convention were the following: Ward 4—George Hutchins; Ward 6—Ansel L. Sweet; Ward 7—W. G. Lawton; Ward 10—Charles Dowler.

The firm of J. Lothrop & Co., who made an assignment last Fall, will resume business at once, all claims of the creditors having been adjusted. Joseph H. Lindsay, formerly foreman for Waite, Mathewson & Co., has been admitted to partnership.

John C. Knowles, son of the late Joseph and Mary C. Knowles, died at his residence on Benevolent St., this city, on Wednesday last, in the 47th year of his age. He was identified at one time with the manufacturing jewelry business in this city as a member of the firm of T. J. Gardiner & Co. He leaves a widow, a son and one daughter.

### Philadelphia.

The estate of the late Thos. W. Bailey placed his personalty at \$33,631.

Geo. W. Scherr and Jules Levy made a flying trip to Lancaster last week.

Harry Schimpf was confined to the house several days last week by an attack of the grip.

A. R. Justice and Sam'l Biddle spent several days on business in New York last week.

The effects of Taggart & Nicholas, sold last week by the sheriff, fell far short of the creditors' expectations.

Bernard Levy has opened a gold case and watch repairing establishment and has issued an elaborate prospectus in connection therewith.

Geo. W. Scherr has donated to the relief association of the New York Jewelers' Board of Trade, a fine blooded mare to be raffled for by local members of the trade. The chances are \$1 each and it is expected that \$500 will be realized from the enterprise.

Among travelers here the past week were: Sumner Blackinton, W. & S. Blackinton; Frank Woods, Carter, Sloan & Co.; J. Granbery, Reeves & Sillocks; John Taylor, Kremontz & Co.; Chas. Duffy, Enos Richardson & Co.; Clifford Booth, Hutchison & Huestis.

The judgment creditors of the Philadelphia Optical & Watch Co. have appealed to the Supreme Court against the decision of Judge Finletter, authorizing the receivers to sell the stock of the embarrassed concern. President Lowry, of the Keystone Watch Case Co., is taking an active interest in behalf of the creditors.

Lena Bailey, an accomplished confidence operator, was arrested here last Friday on the charge of obtaining goods from several jewelry and optical goods stores by false pretences. She was detected at the establishment of H. C. Boden & Co., and among the other places where it is suspected she operated successfully are: J. E. Limeburner, Hamilton & Diesinger, Bailey, Banks & Biddle, and S. M. & S. R. Friedenberg. The girl is only 21 years old, was very handsomely dressed and her general appearance offered facilities for her dishonest operations.

In the Orphans' Court on Friday an adjudication was filed in the case of the estate of Louis H. Spellier, the electric clock inventor, who died in August, 1891. Mr. Spellier, after sundry bequests to various parties, left the income on part of his possessions to Emily Stankowitch, to whom he was engaged to be married. There was a contest over the will, but its validity was finally sustained. There was a fund at this time before the court of \$5,105.05, out of which a number of payments were made, and \$2,666 97 was placed in trust to provide income for Miss Stankowitch.

### Pittsburgh.

G. B. Barrett has returned from a two weeks' visit to New York.

Chas. Roberts, of E. P. Roberts & Sons, is at his home in Oakland very ill.

A cablegram has been received from J. R. Reed, announcing his safe arrival at Gibraltar.

S. L. Ginsburg will start in the wholesale business, and not H. Ginsburg, as reported in last week's CIRCULAR.

Wm. Hering, of Butler St., has sold the property where his store now is, and will remove April 1st, two squares from his present location.

W. Meyers, lately with August Loch, and now with Mr. Steineman, of Allegheny, will shortly go into business for himself in the new Masonic building, North Ave.

M. Bonn & Co. removed to their new building on Penn Ave., during the past week. A large force of workmen is rapidly getting the store rooms into first-class condition. Heeren Bros. & Co. will remove in four weeks into their new building adjoining Bonn's.

Among buyers in the city last week were observed: J. B. Bruce, Burgettstown; T. E. S. Griffen, Elizabeth; F. J. Manson, Jeannette; A. A. Poole, Washington; L. T. Chapman and R. F. Hardie, adjusters of the stock of E. S. Hutchins, Kittanning; G. A.

Johnston, Cadiz, O.; E. A. Blose, New Kensington; Wm. Hunt, Uniontown; J. C. Rhodes, Homestead; R. A. Cunningham, Leechburg, and John Zugschwert, Mansfield.

### Canada and the Provinces.

Nickerson & Elliot, jewelers, Moncton, N. B., have sold out.

Charles Addison, jeweler, Ottawa, Ont., has assigned to C. H. Carriere.

Rachel Dreyfus, Montreal, Que., has registered as trading under the style of H. J. Dreyfus & Co.

Maurice Feeley, representing the Meriden Britannia Co., Hamilton, Ont., was in Montreal last week.

A. R. Harmon, representing Robbins & Appleton, Montreal, Que., is spending a few days in Boston, Mass.

T. Brady, formerly western traveler for P. W. Ellis & Co., Toronto, Ont., has now joined the forces of Smith & Patterson, and makes Montreal his headquarters.

The sheriff is in possession of the jewelry stock of A. Goebel, New Hamburg, Ont., whose father made him a present of \$2,000 when he began business three years ago. Nearly all of this seems to have disappeared.

Joe Parker, representing the Canada Refining and Smelting Co., London, Ont., passed through Montreal last week on his return from a four weeks' trip to Quebec and the Lower Provinces. His trip was successful.

The *Official Gazette* of last week contained notice of the application of the Holmes Electric Protection Co., for an extension of their charter, giving them powers to issue policies of insurance to guarantee banks, jewelers, warehouses, private residences, etc., from burglary.

The clerk of E. S. Cole's branch jewelry store, Drummondville, Ont., found the door one day last week unlocked, and investigation revealed that the place had been rifled. A hole nearly an inch long was found drilled into the safe, and it was clearly the intention of the men to blow it open, but evidently they were frightened away by people returning from a dance.

A meeting of the creditors of Edmund Eaves & Co., Montreal, Que., will be held to-day, Wednesday, to discuss the situation. Three tenders have been sent in, but none are satisfactory to the curators and they have decided to let the creditors decide in the matter. The estate if properly managed should pay 35 cents on the dollar but it is likely the creditors will receive much less.

### St. Louis.

The death occurred a few days ago of C. Aug. Calame, of C. Aug. Calame & Marchal, 622 Locust St.

The Temple building caught fire about 10 A. M. last Wednesday. Among those who suffered more or less loss were jewelers Theo. Eagle and J. H. Buckroeder.



## IN APPRECIATION OF THE CIRCULAR'S SILVER ANNIVERSARY NUMBER.

KIND WORDS EXPRESSED TO THE CIRCULAR'S CORRESPONDENTS.

**Chicago.**

Without exception Chicago jobbers are enthusiastic in praise of THE CIRCULAR'S silver anniversary number. Space cannot be given for all the many pleasant expressions of opinion, but the high merit of THE CIRCULAR acknowledged by the leading jobbers as given below, is a reflex of the opinion of the trade generally:

Julius Schnering, of Otto Young & Co.:—"The finest book I ever saw. Too much cannot be said in its praise. It was a reflection of the plane THE CIRCULAR has reached and was a remarkable issue in every respect."

James A. Todd, manager Towle Mfg. Co.:—"It was a very, very creditable number. It was my intention to write my personal congratulations, but did not because a letter could not half convey my idea of the excellence of the number."

Benj. Allen, Benj. Allen & Co.:—"It was very fine. THE CIRCULAR deserves high credit for getting up such a nice paper. It is better than has ever been issued by any previous administration."

B. F. Norris, B. F. Norris, Alister & Co.:—"It was comprehensive and fully covered the field. The paper was the prettiest I have ever seen. The reading matter was thoroughly enjoyable, and I was particularly interested in the Tiffany article. We would like to see such an issue oftener."

Peter Lapp, Lapp & Flershem:—"A very fine book; a fine edition in every way. The advertisements and reading matter were alike interesting and the general get-up was excellent."

J. W. Meacham, Meriden Britannia Co.:—"It is a beauty. I have set it aside for the purpose of making a thorough study of it. The book is the finest I have ever seen and highly creditable to THE CIRCULAR. THE CIRCULAR is the finest publication on the market to-day."

**Philadelphia, Pa.**

Simon Muhr, H. Muhr's Sons:—"I perused the silver anniversary number of THE JEWELERS' CIRCULAR with a good deal of interest and pleasure. It was a remarkably well prepared publication, and its excellence furnished a striking proof of the great strides special publications—especially in the jewelry trade—have made in recent years. Such an achievement as that which has just been accomplished by THE CIRCULAR would have been out of the question a quarter of a century ago. As the scope and usefulness of THE CIRCULAR have unclosed so has the trade itself extended, and the magnificent number celebrating its silver anniversary demonstrates the wonderful advance in both. Such publications as THE CIRCULAR are indispensable to the trade they serve, and deserve the most liberal encouragement. My heartiest well-wishes are with the managers and editors of the journal in their future efforts."

D. F. Conover, D. F. Conover & Co.:—"The quantity and quality of the matter in the silver anniversary number of THE JEWELERS' CIRCULAR struck me as an evidence of the wonderful enterprise and resources of the paper. I read it pretty nearly from cover to cover, and I don't suppose I skipped many of the advertisements either. The publishers deserve vast credit for what they have done, and I guess they merit the thanks of the trade as well. THE CIRCULAR has always been my favorite trade paper, not only for the variety and extent of its news, but for its usefulness from a most technical standpoint. The recent big number I regard as a great success, and I have heard it commended in every direction. Let THE CIRCULAR grow and prosper."

George W. Scherr, L. A. Scherr & Co.:—"THE JEWELERS' CIRCULAR was always a model trade paper

and we looked for a handsome anniversary number. For my part I was surprised at the beauty, extent and excellence of the paper. Typographically it was of a very high character, its original matter was surprisingly varied and interesting, and its 'get up' in every way was a marvel of experienced judgment, taste, industry and enterprise. The popularity which THE JEWELERS' CIRCULAR enjoys among our people in Philadelphia has certainly lost nothing by this brilliant celebration of its twenty-five years of useful work. On the contrary, it ought to be, and no doubt will be, still more popular, if that be possible."

John C. Kelley:—"I take great pleasure in expressing my sense of pleasure at reading the silver jubilee issue of THE JEWELERS' CIRCULAR, and I heartily congratulate every one connected with the publication upon an achievement that I suppose has never been excelled in the annals of trade journalism. Every feature in the anniversary number had its special merit, while the mechanical excellence of the book—for that is what it might properly be called—deserves to be highly commended. I was impressed by the resources of the publishers as demonstrated by the sketches of the correspondents from every section of the country. THE CIRCULAR is certainly a great paper, and it deserves all sorts of prosperity and success."

E. B. Fox, Queen & Co.:—"The silver anniversary number of THE JEWELERS' CIRCULAR was a highly artistic and generally splendid publication. In every sense it possessed interest for those in every branch of the trade, and I cordially congratulate THE CIRCULAR upon what it has done. The liberality and enterprise evinced in the very elaborate anniversary number should demonstrate that the journal is closely in touch with the interests of the trade, and it should be supported accordingly. It is only a well equipped trade journal that can issue a special number of the superior excellence that marked THE CIRCULAR'S recent effort."

A. Herzberg, I. Herzberg & Bros.:—"I read with a great deal of gratification the silver anniversary number of THE CIRCULAR. It was a remarkably stylish affair, so to speak, and reflects the greatest credit upon the publishers. There wasn't a line in it that wasn't well worth reading by members of the trade. There must have been a vast amount of labor expended in the preparation of such a number, and certainly the result was a grand one. THE CIRCULAR is a reliable paper for us, and it reaches every branch of the business. The earnestness of its mission was demonstrated by its great special issue marking its twenty-fifth anniversary."

**Boston, Mass.**

Boston jewelers have but one opinion regarding THE CIRCULAR'S special number. They agree unanimously that it was a gem. Here are a few of the comments:

A. T. Sylvester, H. T. Spear & Son:—"I looked it through carefully and with a great deal of pleasure. The issue was very handsomely gotten up, and I found the contents exceedingly interesting."

Harwood Bros.:—"It's a beauty, a gem from the richest of mines, the mines of thought and art. We've had THE CIRCULAR ever since it started, and it has always been a welcome visitor."

Floyd, Pratt & Co.:—"THE CIRCULAR'S productions heretofore have always shown much artistic merit, but the silver anniversary number transcends all previous efforts and must be pleasing to the entire trade. Though the oldest of the jewelry trade papers, it shows none of the rust of age, and we consider it one of the foremost trade journals of the country."

M. N. Smith, Smith & Patterson:—"A splendid number. The special features were not only interesting, but they contained useful information for dealers. I devoted more time to its contents than I ever felt like giving a trade paper before. There was so

much real merit in its historical and descriptive articles that I considered it the most valuable issue for the trade I have ever seen."

**Detroit, Mich.**

The recent issue of the silver anniversary number of THE CIRCULAR, has been received with favor and pleasure by the trade of this city. Among the many pleasant things said were the following:

Henry Wright, of Wright, Kay & Co.:—"I take considerable interest in following the growth and enterprise of the various trade journals, but as far back as I can remember, there has been no publication that can equal the beauty of THE CIRCULAR'S silver number. Its pages are full of meat. Typographically, I don't think it could be excelled."

Eugene Deimel, jobber, had not yet taken time to read it but said he had laid it aside for a future treat. From an advertising point of view, he thinks it is the most complete of anything heretofore published.

"I shall keep mine as a souvenir," remarked Adolph Enggass. "It is something that the average jeweler will carefully put aside for future reference. It is a model of neat and appropriate typographical work."

Ed. Roehm, of R. J. F. Roehm & Son, says that the firm are very much pleased at the beauty and completeness of the number. "The paper has kept fully abreast," said he, "with the progress made in our trade and should receive its support."

"It was a very creditable effort," remarked Henry Koester, "and must have required considerable thought and labor to produce it."

**Kansas City, Mo.**

The special edition of THE JEWELERS' CIRCULAR issued this month to celebrate its twenty-fifth birthday was received with much praise in Kansas City, where the paper has many friends. The following are a few of the expressions of favor received:

Mr. Hoefler, Woodstock, Barger & Hoefler:—"The silver anniversary number of THE JEWELERS' CIRCULAR was one of the prettiest publications I have ever had the pleasure to see. It shows what brains and printer's ink can do when judiciously mixed."

George H. Edwards, secretary Edwards & Sloane Jewelry Co.:—"The silver CIRCULAR was certainly a handsome publication, a worthy representative of the many hundred copies of the paper, which has been steadily widening its circle of friends for a quarter of a century."

Herman Oppenheimer, Herman Oppenheimer & Co.:—"That issue of THE CIRCULAR will make many new friends for the paper."

Chauncey B. Olmstead, Cady & Olmstead:—"That issue of THE JEWELERS' CIRCULAR surpassed any of the literary publications of New York in point of typographical and artistic beauty, and in point of literary excellence. It is the best publication of the kind ever made."

Eugene Jaccard, Jaccard Watch and Jewelry Co.:—"The silver anniversary number of THE JEWELERS' CIRCULAR was simply grand. It is the best and most complete issue of a trade paper it has been my privilege to see. I think it is safe to say that THE CIRCULAR has reached the acme of class journalism. The reading matter, which was presented in such a pretty form, was exceedingly interesting. We always keep THE CIRCULAR in our office to be handy for reference, and we have already received several suggestions from this one issue."

J. Russ Mercer:—"The special edition of THE JEWELERS' CIRCULAR was a creditable piece of work. It



shows what skilful newspaper men can do, when they have ingenious jewelers to write about and their work to picture. I enjoyed looking at the artistic advertisements, as well as at the special articles."

#### Pittsburgh, Pa.

I append a few remarks made by leading jewelers on the anniversary number:

Steele Roberts, of E. P. Roberts & Sons:—"Your CIRCULAR people have surpassed themselves in the anniversary number. It is one of the most interesting publications that I have seen for a long time."

Henry Barrett, G. B. Barrett & Co.:—"I tender my congratulations to THE CIRCULAR management on the beautiful silver anniversary number. THE CIRCULAR certainly has no peer among trade journals."

I. Ollendorf:—"THE CIRCULAR anniversary number is a beautiful book, full of interesting reading, and any library table should be honored by its presence there."

Wm. Heeren, Heeren Bros. & Co.:—"That is a remarkably fine issue of THE CIRCULAR this week. We have all been busy reading it since it arrived."

B. E. Arons:—"THE CIRCULAR'S anniversary is really 'bang up' and very interesting. It is certainly equalled by none."

C. W. Wattles, W. W. Wattles & Sons:—"We received your anniversary number last week. It is more than handsome, and is highly educational to the trade."

Emil Bieler, Heckel, Bieler & Co.:—"The anniversary number is a great success, and has been admired and read not only by ourselves, but by many of our customers and visiting travelers. It is particularly fine."

These are but few of the hearty commendations on the anniversary number. The leading salesmen in all the stores likewise came to me expressing their approbation of and interest in the paper.

#### New Haven, Conn.

Words of praise for THE CIRCULAR'S elegant anniversary issue:

S. H. Kirby:—"It was certainly very interesting and a fine piece of journalistic enterprise, most creditable in every way. In the pressure of business I have not yet had time to peruse all of its very interesting features. It is yet a feast in reserve. The enterprise displayed is most commendable."

S. Silverthau's Sons:—"It is immense; highly creditable, and admirably gotten up. It is the finest thing ever published in the line in this country. THE CIRCULAR is far in advance of any other jewelry publication in the United States. It easily leads and distances all competitors."

Wells & Gunde:—"We never have seen anything finer in the line in this country. It far surpassed anything in the line ever before produced, to our knowledge."

S. Goodman & Co.:—"It was first-class in every respect. It would be hard to improve upon it. It was most creditable, and an honor to the trade."

#### Syracuse, N. Y.

Following are the opinions of several of the prominent jewelers of Syracuse in relation to the silver anniversary number of THE CIRCULAR:

H. J. Howe:—"The silver anniversary number of THE CIRCULAR we consider a very fitting celebration of so interesting a jewelers' paper, and it has received many very flattering compliments from all who have seen it here."

E. B. McClelland:—"It gives me great pleasure to have an opportunity of expressing my thoughts of THE JEWELERS' CIRCULAR souvenir number. It is replete with interesting matter, compiled with care and intelligence. May the years intervening until its golden anniversary be full of success."

C. E. Eager:—"I think the February number of THE CIRCULAR is a beautiful edition, and it has been very much admired by everyone that chanced to see it lying on my counters, where it has been ever since received."

E. G. Seymour:—"We consider the February num-

ber of THE JEWELERS' CIRCULAR the most artistic and complete exemplar of a trade periodical extant. Artistic, concise and thoroughly readable in all its departments—a complete specimen of magazine work."

C. S. Ball:—"Have read the souvenir number of THE CIRCULAR with much pleasure, noting the familiar names of many who were firmly established in the trade when the writer was struggling for his first dollar. It is an attractive and comprehensive number and will well repay careful perusal."

#### Springfield, Mass.

The arrival of the silver anniversary number of THE JEWELERS' CIRCULAR in this city brought forth many congratulatory expressions from local jewelers, and many pretty things were said regarding it. Everyone praised it, and the unanimous opinion is that it is the finest work ever issued in the interest of the trade. Some of the prominent jewelers were seen and asked to express an opinion about the number and did so unhesitatingly.

Among those seen was F. A. Hubbard, who said in substance:—"It is the finest thing of its kind that I have seen, and I had intended writing the publishers to congratulate them upon their success. The general typographical work of the number could not be surpassed, while the cover is a work of art. THE CIRCULAR has always been a favorite with me and its hold is strengthened by the appearance of the number which marked its silver anniversary."

L. S. Stowe:—"It is the best thing they have ever published, and I can say with truth that it is the best number ever published by any paper in our trade. In fact it far exceeds any previous publication. It bears upon its face the impression of care and study, and it is certainly gotten up in the best possible manner, and its cuts are well executed and its reading matter carefully selected and ably presented."

E. E. Penny, of Eldredge & Penny, warmly seconded Mr. Stowe's remarks. Mr. Penny said that a particularly noticeable feature of the issue was the number and quality of the illustrations. These Mr. Penny characterized as very fine. Another feature which interested him was the articles illustrating the growth of the jewelry business. In fact he was much pleased with the entire number and freely said so.

#### Lancaster, Pa.

The many complimentary words spoken by members of the trade of the silver anniversary number of THE CIRCULAR have doubtless caused the publishers' ears to tingle in a lively way since its issue. Among the opinions caught "on the fly" were the following:

Willis B. Musser, manager of the Non-Retailing Co.:—"If a thing of beauty is a joy forever, THE JEWELERS' CIRCULAR may plume itself on affording a very long period of happiness to the trade in presenting its sumptuous silver anniversary number. It is altogether a very notable example of the possibilities of trade journalism, and we congratulate its publishers on the enterprise which has materialized in such a superb edition of 'the oldest of all the jewelry publications.' What visions break upon one who attempts to forecast the golden anniversary number!"

Aug. Rhoads:—"The silver anniversary number of THE CIRCULAR is the finest publication that has ever been presented to the jew'ry trade. Aside from the sumptuous character of the work, the literary contents are of a very high order and assure the preservation of the number in every jeweler's library."

W. W. Appel said that, after giving the silver number several casual inspections, he has now started in to read it through from cover to cover. "It is the biggest feat in trade journalism of which I have any knowledge and is sure to make THE CIRCULAR more popular than ever."

Frank B. Fon Dersmith:—"The silver number of THE CIRCULAR is such an embarrassment of riches that I am digesting it in sections. The trade has cer-

tainly never had anything finer presented to it for consideration and criticism, and the universal chorus of praise should be very flattering to the publishers."

#### Indianapolis, Ind.

"A very creditable piece of work full of interesting matter and handsomely gotten up."—F. M. Herron.

"A great piece of enterprise and deserving a great deal of credit."—Silas Baldwin.

"Everyone in the store appreciated it. All the clerks and workmen asked the privilege of taking it home to read. A very beautiful issue and well worthy of the occasion."—Carl F. Walk.

"Was on the point of writing a letter of congratulation to the publishers who have shown very commendable enterprise in getting up an edition of such artistic and literary merit."—E. C. Miller.

#### Louisville, Ky.

Wm Kendricks' Sons said concerning the anniversary number of THE CIRCULAR:—"It is as a whole a magnificent piece of work; its articles are very interesting. THE CIRCULAR is a model trade journal."

"THE CIRCULAR is newsy and neat, containing all the news of the day."—D. S. McNichols.

"THE CIRCULAR of the present is quite an improvement on the old, and very interesting. It has men of push behind it who understand their business and will keep it to the front."—S. S. Lieberman.

"THE JEWELERS' CIRCULAR is the best trade journal and has pointers in it that are very interesting and instructive. The anniversary number is unsurpassed by anything before published."—Buschemeyer & Seng.

#### Elmira, N. Y.

The jewelers of this city were all delighted with the magnificent souvenir edition of THE CIRCULAR. They are reading it yet and will treasure it long as a pleasing memento of modern journalism.

Lewis Bally, of Bally & Son, was among the many jewelers who were delighted with the number. "It is a corker; it is certainly an elegant piece of work and its articles are all interesting and readable."

Edward P. Bevilard told your correspondent that it was an elaborate issue, and certainly a most excellent number. He was highly pleased with the work.

Major Henry Drake:—"It is a very pretty number and the finest issue of its kind that ever I see. Its contents are excellent."

A. J. Watson:—"It is an elegant number. It is gotten up in such beautiful style and its features are all splendid and interesting. Don't you want to look at it?"

#### Birmingham, Ala.

The jewelers of Birmingham are unanimous in the opinion that the silver anniversary number of THE JEWELERS' CIRCULAR is the finest and most complete edition of any journal of the jewelry trade ever issued in this country. Here are the opinions of a half a dozen of the leading jewelers on the subject:

William Black, Gluck & Black, said:—"The silver anniversary number of THE CIRCULAR was a magnificent showing for the publishers of the best jewelry journal in America; besides, it reflects great credit upon the trade that it can support such a journal. I have carried my copy home and will preserve it as a souvenir."

Harry Mercer said:—"I think THE CIRCULAR'S silver anniversary was just grand. It surpassed any publication of the kind that I have ever seen. I will write the publishers a letter complimenting them on furnishing the trade with such a splendid publication, which is in itself a jewelers' encyclopedia. I am one of THE CIRCULAR'S oldest subscribers, and to read the anniversary number carried me back to my young days, when I perused the history of all the old firms whom I know. It is the finest journal of the trade."

William Rosenstihl, Rosenstihl Bros., said:—"The publishers of THE CIRCULAR deserve great credit for their silver anniversary. It is the best ever issued to the trade. Every jeweler ought to have and preserve



a copy of it. THE CIRCULAR is the most enterprising and accurate of all trade publications, besides it has the liveliest corps of correspondents."

H. C. Abbott, H. C. Abbott & Bro., said:—"THE CIRCULAR is the best jewelry paper in the country, and its silver anniversary number is the handsomest and most complete publication of the kind I have ever seen. It is brimful of information that is indispensable to the trade, all of which is interspersed with enough reading matter to entertain a jeweler for a long time. We will preserve our copy for reference."

A. Speaker, the oldest jeweler in Birmingham, said:—"It's a wonderful improvement over any jewelry publication I have ever seen in my long career. It is, in fact, the most complete journal in every way that has ever been issued to the jewelry trade in America."

Charles Kaelin said:—"THE CIRCULAR's silver anniversary surpasses anything of the kind I have ever seen before. I don't see how any jeweler can afford to miss it, as it contains a world of valuable information."

**Canton, O.**

The leading jewelers of the city were very much taken with the silver anniversary issue of THE CIRCULAR and the comments upon it and the regular paper, were without exception, very flattering.

George Deuble said:—"The issue was very fine, the best they have ever gotten up. It is always a very good paper. I have been a subscriber for a good many years."

Chance & Rose:—"It is an elegant thing from every standpoint, typographically and also with regard to the reading matter. We have been subscribers to THE CIRCULAR for many years."

Deuble Bros:—"It is better than any previous issue we have had; it is very complete and made a very good impression."

W. A. Wortman:—"It is a fine production. The reading matter covers a very wide field and brings us in touch with jewelers all over the country."

**Rockford, Ill.**

The silver anniversary number of THE CIRCULAR was received with much favor by the Rockford jewelers.

Said Al. E. Henry:—"It is a very handsome number, one of the best things I have seen in a long time."

N. E. Benoit:—"The anniversary number of THE CIRCULAR is a very pretty thing."

D. F. Sullivan:—"The silver anniversary number of THE CIRCULAR is simply great. It is complete in every respect. I purchase goods of many of the houses that patronize its advertising columns."

J. Beall & Bro.:—"THE CIRCULAR's special number was pretty and complete, and denotes the enterprise of the publication."

Skandia Watch and Jewelry Co.—"Prettiest thing seen in a long time. It is a first-class journal."

**Bangor, Me.**

The twenty-fifth anniversary number of THE JEWELERS' CIRCULAR was received with great favor by the jewelers in this city.

W. C. Bryant in speaking with your correspondent said that he thought it was a very nicely gotten up thing.

S. L. Rogers, with Bernhard Pol, said he thought it was a very fine publication and it would tend to create interest among the jewelers and somewhat develop the jewelry business.

Adolph Pfaff said that the anniversary number was very interesting.

**Davenport, Ia.**

Mrs. T. Kircher:—"Very interesting and very nice; far above our expectations."

M. E. Nabstadt:—"It is a beauty. We can't do without THE CIRCULAR. Here's our subscription."

A. C. Billon:—"Finely gotten up. It is a work of great artistic merit."

C. S. Durfee:—"There can be but one expression—that of appreciation of the enterprise that resulted in such a number."

**Columbus, O.**

The jewelers awaited the advent of the silver anniversary number of THE JEWELERS' CIRCULAR with eager anticipation. Judging by the regular numbers of THE CIRCULAR, they felt justifiable in expecting something beyond the ordinary, but the silver anniversary exceeded their expectations.

Said Frank F. Bonnet:—"I have taken it out to my house. I have been able to get only a part of the way through as yet. I have been greatly interested in the various articles. Have taken THE CIRCULAR for about 20 years, yes, all of 20 years."

Barnitz & Nunemacher were very enthusiastic in their admiration of the special issue. "It's elegant and no mistake," said Mr. Barnitz. "We would have to break up housekeeping if we didn't have THE JEWELERS' CIRCULAR," Mr. Nunemacher added.

When your reporter asked T. T. Tress what he thought of the special edition, he reached under the counter and drew it from beneath a promiscuous lot of packages, where it was carefully wrapped in a newspaper. "I have to keep it guarded," he said. "All of the men want it, and while they shall all see it in time, I am just selfish enough to want to get through with it myself first; and I find it so full of interesting matter that I am afraid their chances at it are slim for the present. It's an elegant thing and no mistake."

"They have done themselves proud," said Mr. Gerlach. "It is not only full of good material, but is a beauty in appearance."

"It's fine in every respect," said Mr. Harrington. "As fine a work of the kind as I ever saw. They are to be congratulated."

"Have you seen the special number of THE JEWELERS' CIRCULAR?" asked Mr. Bourquin, of a traveling man; "It's the finest thing we've seen. We keep it here to show to our special friends. Everyone admires it and speaks highly of it."

Wm. M. Savage, of the Columbus Watch Factory, said he had been anticipating something beyond the ordinary as he had known of the enterprise and ability of THE JEWELERS' CIRCULAR PUBL. CO., but that when he saw the silver anniversary issue it exceeded his highest expectation.

Miss Emma Geach, engraver with the Gerlach house, said the work was fine.

Mr. Tucker said he had heard the highest compliments on all sides.

Mr. Koch thinks it a beauty from beginning to close.

**St. Joseph, Mo.**

Mr. Hartwell, J. F. Hartwell & Co., said that the "silver anniversary number of THE CIRCULAR was an elegant piece of work in every detail."

Mr. Kirkpatrick, W. F. Kirkpatrick & Co.:—"The silver anniversary number of THE CIRCULAR is the nicest thing ever seen among the jewelry trade journals."

L. Burnett, Louis Burnett & Co.:—"We fortunately received two copies of the silver anniversary number of THE CIRCULAR, and we are glad to state that it is an excellent work, and we think that the publishers of THE CIRCULAR in general ought to be proud of such a beautiful work. We think that the articles on The American Watch as a Product of Nineteenth Century Genius is of the greatest value to the legitimate watchmaker."

**The Attleboros, Mass.**

The opinion of all who received the silver anniversary number of THE CIRCULAR was that it was the prettiest and most interesting number of a trade publication ever received in this section of jewelry-dom.

**FOR EASTER  
BOOK MARKS**

IN STERLING SILVER.

50 Cents.

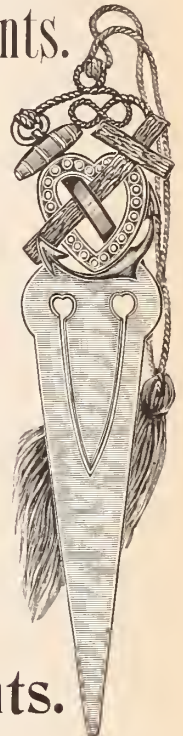

50 Cents.

**ALVIN MFG. CO.,**

... SILVERSMITHS ...

860 Broadway, = = New York.

**J. PRINCE,**  
Jewelry Auctioneer,

At liberty from January 1st, 1894. Retail Jewelers only. Address,

Rooms 9 & 10, 137 BROADWAY  
N. Y. CITY.

**Three Great Successes.**  
Our Industrial School of Optics Practical  
Our Swell Gold Construction Progressive  
Our Prescription Department Punctual  
**ASSURED SUCCESS TO YOU**  
If you take the Practical course in refraction, sell The Swell End Eyewire Gold Spectacles and Eye Glasses, and send your Prescription work to our special department which you will find accurate and punctual.  
Avoid delay and errors by keeping in mind the old reliable  
**Spencer Optical M'f g Co.**  
15 MAIDEN LANE, NEW YORK.

**G.A. WEBSTER**

42 & 44 Madison St., Chicago, Ill.

**Manufacturer,**

AND WESTERN AGENT FOR

E. G. WEBSTER & SON, of Brooklyn, N. Y.

A. F. TOWLE & SON CO., of Greenfield, Mass



THE STEADY PROGRESS WESTWARD TAKES ITS WAY!

# WESTERN SUPPLEMENT of THE JEWELERS' CIRCULAR

Chicago Office: Room 308, Inter-Ocean Building.

VOL. XXVIII.

CHICAGO, WEDNESDAY, FEBRUARY 28, 1894.

No. 4.

## Chicago Notes.

J. W. Forsinger returned Wednesday from St. Paul, Minn., where he had gone on railway watch inspection business.

Moses Goldsmith, of Goldsmith Bros., has been confined to his home the past week with the grip, but is convalescing.

E. G. Webster and A. W. Sturdy contemplate a trip to the coast. J. F. Ripley, of Watson, Newell & Co., left for the Pacific coast Saturday.

In accordance with a time honored custom the jobbing trade as a rule closed their places of business at 12 o'clock noon, Feb. 22, Washington's Birthday.

Mr. Alister, of B. F. Norris, Alister & Co., is accompanied by his family on a three months' visit to California resorts. The larger part of the time will be passed at Coronado Beach.

At the late election of the Board of Governors of the Chicago Athletic Association manager R. A. Kettle, of the American Waltham Watch Co., was re-elected a member of the board for a three years' term.

P. F. Pettibone & Co., wholesale stationers, 48 and 50 Jackson St., have purchased the John Morris Co. and more than doubled their facilities for commercial printing and other stationery requisites for business houses.

Fred. Weigle, formerly with the Weber Co., is representing Sophus Samson, 801 Columbus building, in the city and on the road with a new line of art enameled flatware plated on base metal, the products of a Copenhagen factory.

M. F. Thornton, representing Aikin, Lambert & Co., reached Chicago the latter part of the week for a few days' visit. Manager Jenkins will divide his duties the coming season between the office and his old territory in Indiana, Illinois and Wisconsin.

The following are a few among the buyers who brasted the storms to visit the Chicago trade last week: E. J. Peck, Braidwood and Gardner, Ill.; A. G. Goodspeed, Minonk, Ill.; C. W. Kirstetter, Goshen, Ind.; C. J.

Linden, Kankakee, Ill.; Mr. Lockwood, Jr., Chariton, Ia.; R. J. Spencer, Racine, Wis.

A. W. Sproehnle, of F. M. Sproehnle & Co., returned the 17th inst. from Iowa and reported he was much encouraged. This was Mr. Sproehnle's first trip in this territory, and he is highly pleased with the personality of the Iowa trade. They are a lot of bright business men, whom it is a pleasure to meet, said he. Mr. Sproehnle left Monday to become more closely acquainted with the Illinois customers of the house.

Three safe-blowers were frightened away from S. Buchsbäum & Co.'s manufacturing jewelry establishment, 179 Madison St., at an early hour Friday morning. They had drilled the safe which contained \$13,000 worth of diamonds and jewelry and were about to break into the strong box when John Reece, a porter in Henric's restaurant frightened them away. They left their tools which were taken to the central station and officers were detailed on the case.

A bold robbery occurred Feb 19, the Meriden Britannia Co. being the losers. Between 11 and 12 o'clock noon that day a thief pried open a display case filling a niche under the stairway in the hallway on the first floor and filled a sack with the silverware the case contained. State St. at this time of day is densely crowded and the thief escaped without leaving a clew. The detectives in charge of the case say that seven complaints of a similar nature have been reported within the past few days.

The following official copy of awards was received Thursday from John Boyd Thacher, chairman of the executive committee of awards for the World's Fair, by the Crown Pen Co., 78 State St.: "Awards—Fountain Pens: 1st, Positive excellence of action of feed; 2d, writes the moment the pen touches the paper; 3d, does not overflow or skip." This covers exhibit 89 of manufactures. Awards on gold pens in general and pen making machinery will be received later. "In due time," writes Mr. Thacher, "the awards will be inscribed on the diploma and forwarded to you."

B. Grieshaber, 96 State St., was officially

notified of the following awards, made by the World's Fair executive committee, for the following specific points of excellence in gold pen manufacture: 1st, Smoothness of points; 2d, excellence of finish; 3d, the oblique pens are specially well shaped and finished. B. Grieshaber has opened an office and salesroom at 96 Great Dover St., London, S. E., England, and is represented in that city by T. Harold March, who traveled for the firm the past season. The increasing trade of the firm with England and the Continent the past year necessitated the establishment of a London salesroom for the convenience of the foreign trade. The foreign office carries a full line of stock, manufactured by the Chicago house. Mr. Grieshaber has received a request from a prominent Japanese house asking for the agency of the firm in their country.

G. W. Marquardt & Sons moved into their new quarters, room 401 Columbus building the past week, and opened their full lines of entirely new goods Monday, ready for business. The quarters are handsomely furnished and finely appointed. To the left as one enters extends a mahogany counter the entire length of the room with a line of huge safes to the rear. On the right are handsome chain cases, and further on a glass topped partition separates the offices and shipping rooms from the main salesroom. A solid rail 2½ feet high, with swinging gate, joins the partition and counters. Adjoining the general offices and shipping department are the commodious and pleasant private offices of the firm. The furnishings throughout are in solid San Domingo mahogany, highly polished, with openings in partitions filled in with Japanese bronze grill work. The firm established at Iowa City, Ia., in 1854; moved to Des Moines in 1881; incorporated with G. W. Marquardt as president, G. W. Marquardt, Jr., as treasurer and C. G. Marquardt as secretary in 1885, and now with characteristic energy and foresight seek the wider field for effort that Chicago affords. The firm carry a large line of watches and general jewelry.



**F. G. Smith, Sons & Co. Make An Offer in Composition.**

DETROIT, Mich., Feb. 24.—The affairs of F. G. Smith, Sons & Co. will probably be arranged so that the business will be continued, providing the creditors give an extension of time. It is said that they have offered an immediate settlement of 50 cents on the dollar for all accounts less than \$300, and 100 cents on all above that amount. The firm desire time, however, in which to carry out the second clause. The offer has been taken under advisement.

**Meeting of the American Horological Society.**

CHICAGO, Ill., Feb. 24.—The regular monthly meeting of the American Horological Society was held on Monday evening, Feb. 19th. The applications of A. T. Vuillemot, Prescott, Ark., and D. Furtwangler, Washington C. H., O., were presented, and they were duly elected to membership. The executive committee reported that they had examined the books of the secretary and found the same to be correct.

Mr. Parsons moved that the resignation of Geo. H. Hazlitt as secretary be accepted, and the thanks of the society be extended to him for his services in their behalf. Motion duly seconded and carried. L. F. Hollands then tendered his resignation as chairman of the executive committee. On motion of Mr. Walker the resignation was accepted. Mr. Hazlitt then nominated Mr. Hollands for the position of secretary, and he was elected unanimously to the position. B. Kirner having been nominated, and nomination seconded, he was unanimously elected chairman of the executive committee.

The president then read a communication from D. Furtwangler, Washington C. H., O., in which he offered to the society for use in their library, 35 bound volumes of the *Horological Journal*, 17 bound volumes of the *Deutsche Uhrmacher Zeitung*, 16 bound volumes of the *Allgemeines Journal der Uhrmacherkunst*, and other English and German magazines and books to the number of 75 volumes. Buck & Hall

sent six antique watches to be exhibited in the Society's museum. After an informal discussion on various topics the meeting adjourned to March 12th, when the president will continue his lecture on the mainspring, barrel and hook.

**Cincinnati.**

The board of directors of the Cincinnati Wholesale Jewelers' Association met last week and amended their by-laws.

The semi-annual conclave of the F. & A. M. in Cincinnati last week brought to town

**OPTICAL DEPARTMENTS ESTABLISHED.**



AN EXPERT OPTICIAN will thoroughly establish an Optical Department in a limited number of **FIRST CLASS JEWELRY STORES**, giving his own time as promoter until on a successful basis. Will also give complete instructions in fitting to the man designed as head of the department.

**THERE'S MONEY IN IT.**

Jewelers wishing to make a special run in their optical department or establish one, will find this a rare opportunity. Your business can be increased \$1,000 to \$2,000 a month. Arrangements can be made either on percentage or salary. An unusual opportunity for a good house to

**ENTER A LUCRATIVE FIELD.**

ADDRESS

**OPTICIAN, Care JEWELERS' CIRCULAR, Chicago Office,**

**308 INTER-OCEAN BUILDING, CHICAGO.**



One of the best of the very best.

**QUALITY IS THE STANDARD OF VALUE.**

**CHARGES TO SUIT THE TIMES.**

When interested, write your jobber for new price list for 1894, or

**Moseley & Co., Elgin, Ill.**



No. 2 Moseley Wire Chuck has length, strength, accuracy.



**GIBSON HOUSE,**

**CINCINNATI, OHIO.**

**ABSOLUTELY FIRST-CLASS AMERICAN PLAN HOTEL.**

**\$3.00 PER DAY.**

Extra Charge for Parlors and Rooms with Bath attached. The unequalled advantages in central location, liberal management, modern appointments, experienced service and perfect cuisine, have permanently established the Gibson House as The Most Popular First-Class Hotel in Cincinnati,

AMPLE VAULTS FOR THE PROTECTION OF VALUABLES.

**THE GIBSON HOUSE CO.,**

H. B. DUNBAR

President and Manager

**LOOK OUT**

For our new illustrated Tool and Material Catalogue of 464 pages. It is the largest and most complete catalogue ever issued. We have made many substantial reductions in prices, and can meet the wants of every Jeweler desiring the best goods at lowest possible prices.

\*\*\* **WATCH FOR IT ABOUT MARCH 15TH.** \*\*\*

Should you fail to receive a copy, notify us and we will be pleased to send you one.

**BENJ. ALLEN & CO.,**

**WATCHES, DIAMONDS AND JEWELRY,**

141 AND 143 STATE STREET,

CHICAGO, ILL.



a number of jewelers from out of town.

Charlie Offerman, Wm. Smith & Co., was in town last week.

A new optical goods store is being fitted up in the Arcade.

Mr. Wheat, of Wheat & Hancher, Wheeling, W. Va., I learn, is building a new residence.

Tony Herschede's four-year old child was terribly mangled by a pet bull dog he had had for years at his house. The dog was shot.

Elias Braham has rented one of the vacant Arcade stores and opened up a white stone store, called the Olympia Diamond Parlor.

Mr. Claflin, of Blake & Claflin, says he has had good sales right through from the east. Silver novelties will sell where everything else fails.

An unknown man and woman, last week, went into O. Wildische's jewelry store, and when they left two valuable gold watches went with them, but they didn't buy them.

The local retail jewelers, pursuant to a call from Newton Dexter, have resolved to organize a local association and a meeting

for that purpose is appointed for this week.

Oskamp, Nolting & Co. honored Washington's Birthday by representing Mt. Vernon in miniature in one of their windows. The display attracted the admiration of thousands.

Joe Schwartz, Larry King and Sam Cassiny, the bleached diamond swindlers, who hired a room at 5th and Vine Sts., last November, and tried to operate here, are said to have located in St. Louis, and another report is that Cassiny and Schwartz are in hiding in this city.

Homan & Co. show an entirely new line of Easter novelties this year. They have also turned out a variety of new designs in pin boxes with cushions, jewel cases, and perfume atomizers with silver bottles, vases, etc. Their line is varied and attractive and will undoubtedly prove popular with the trade.

**An Astronomical, Historical and Scriptural Clock.**

A ONE-HUNDRED-YEAR astronomical, historical and scriptural clock, made by Robert H. Sipe, Portland, Ind., has recently been shipped to the Mid-Winter Fair. In the construction of this clock, Mr. Sipes challenges the world for originality, unique features and number of scenes and moving figures. The case is of polished walnut and stands 13 feet high and nine feet wide. The main dial is two feet in diameter and gives both sun and standard time, as well as the days of the month. On its face are a number of smaller dials; one gives the days of the week, another shows the origin of the days by the planets appearing in order, Saturn being visible on Saturday, the sun on Sunday, the moon on Monday, etc.; another dial points out important past events, and days observed by the churches and the so-called unlucky days each month. Other small dials show the time of the rising and setting of the sun, the four cardinal points and the moon's phases, besides its age in days and quarters.

An indicator on the face of an ocean scene gives the tide and their proportional height can be seen when the clock is in operation. The large dial exhibits a table of mortality, showing the proportion of deaths based on a calculation of ten thousand persons.

On the large dial and two small-dials, one used as a key to set the clock for leap year while the other points out the ruling planets from 1876 to 1976. Below the main dial is a smaller one giving the difference in time at the principal cities of the world when it is 12 o'clock noon at Washington D. C.

The solar system is represented by the earth, sun and moon; the sun is in the center and around it revolves the earth in perfect timewith the solar time dial while the moon revolves around the earth in unison with the moon dial, showing the months, seasons of the year and the solstices.

On the top of the clock is a figure of Sir Isaac Newton taking views through his tele-cope which changes position in the quarter of the hours.

On the right of the main dial are three sets of moving figures. The first is Gen. Washington reviewing his army, the second the Presidents of the United States in order, the third the beheading of Mary Stuart. On the left are three other figures: the uppermost showing the flight of time, with the four seasons of the year; the next representing the heroes of 1776 passing before the Goddess of Liberty, who honors each in turn with a bow and wave of the hand, until Benedict Arnold comes and is allowed to pass unnoticed; while the third is a tableau scene picturing the fondness of the elephant for children. There are two more sets of figures below the main dial—in one an upright figure keeps time to music with its hands, while Vulcan strikes the hours on an anvil with a hammer. There are one hundred moving figures and characters on the clock and music boxes that play 18 different pieces.

Mr. Sipes is 49 years old and has spent seven years on this clock. He is a wood-carver by trade and has shown great patience and remarkable ingenuity in the construction of this his masterpiece.

**Two Clues to a Bold, Bad Burglar.**

ST. AUGUSTINE, Fla., Feb. 21.—Mrs. Braithwaite's bric-à-brac establishment, on the north side of the Plaza, was entered by a burglar a few nights ago, who stole silver spoons and jewelry value at \$1,000. A clue to the thief is an old chisel used in forcing open the transom over the back door. After helping himself with valuables the thief forced open the door by taking the pin out of the top hinge.

The evening after the robbery Mrs. Braithwaite recognized a piece of jewelry offered for sale to jeweler C. F. Sulzner by a small negro boy as stolen. The boy claim to have found it. The jewel may lead to the recovery of the property and to the burglar's arrest.

**R. M. JOHNSON,**

IMPORTER OF

**Diamonds AND Manufacturing Jeweler,**

67 WASHINGTON STREET,  
ROOMS 5 & 6,

CHICAGO.

MASONIC EMBLEMS OF EVERY DESCRIPTION MADE TO ORDER.



The only Genuine Chuck is the TRUE Oue.

The only Chuck made invariably true is the Dale.

BUY THE ONLY GENUINE CHUCK,  
THE DALE, \$1.00.

**DUEBER-HAMPDEN WATCHES.**

The most reliable watches are the Hampden 17 Jewel. A full line of Dueber Cases and Hampden Movements. Cash buyers write us.

**BRETHAUER WATCH & JEWELRY COMPANY,**

SPECIAL AGENTS.

71 WASHINGTON ST., CHICAGO, ILLS.

WHEN IN CHICAGO, VISIT THE

**Chicago Watchmakers' Institute,**

SUITE, 1521-1523 B MASONIC TEMPLE.

A Modern Trade School for the Watchmaker, Jeweler and Engraver.

Write for New Catalogue.





### Pacific Coast Notes.

Alphonse Judis, San Francisco, a few days ago, attached L. Bernstein, jeweler, 4th St., for \$3,268, the value of goods purchased from various parties.

On Feb. 20 was commenced the receiver's sale of the stock of Arthur Bob, Vallejo, Cal., on an order and judgment made by the Superior Court of Solano County. The sale will continue till the whole stock is disposed of.

B. Goldberger, of San Francisco, who ran away with a box filled with gems, was arrested last week in Los Angeles, Cal. Goldberger put up at a fashionable hotel and spent money lavishly. The box was recovered, with most of the jewels.

Henry Dietrich, jeweler, Seattle, Wash., has commenced suit against the Great Northern railroad to recover damages in the sum of \$543, alleging that the railroad company failed to deliver to him certain portions of a machine which was expressed from Butte, Mon., to Seattle.

The New York Jewelry Co., of Portland, Ore., was incorporated Feb. 19 with a capital stock of \$20,000, in single shares of \$10, to "manufacture, repair, buy and sell all kinds of privilege and gold and silver ware." The incorporators are C. A. Cove, M. Billings and L. D. McArdle.

Arthur J. Eaton, jeweler, 24 Post St., San Francisco, is lying in the receiving hospital in a precarious condition from a fracture at the base of the skull. In going up the stairs at his home he attempted to free himself from his overcoat, when he tumbled over backwards and fell to the bottom of the stairs, striking on his head. He became unconscious, and as restoratives failed to revive him, he was taken to the receiving hospital for treatment. The physicians who examined him state that his chances for recovery are very slight.

### Walking Jewelry Stores Arrested for Burglary.

PORTSMOUTH, N. H., Feb. 22.—Last Wednesday night the jewelry store of A. P. Wentworth, Saco, Me., was entered by burglars and \$500 worth of goods stolen. Assistant Marshal Casey this week learned that four strangers were in town and had been trying to dispose of jewelry at several saloons and stores. The men were placed under arrest. A search was made of their persons and a stock of jewelry large enough to start a small-sized store was removed. Watches were found sewed into their clothing, and rings and chains were taken from their stocking legs.

Mr. Wentworth, who was notified, at once identified the articles as those taken from his store. The men denied all knowledge of the burglary, and claimed to have purchased the goods. Before coming to this city they visited Dover, where they sold about \$100 worth of their stock. They gave their names as James O. Day, John Rushfort, Edward Deering, William Siddell.

### A Suspicious Customer Visits Newark Jewelry Stores.

NEWARK, N. J., Feb. 24.—Just before noon to-day, and while a young lady bookkeeper was counting a stock of diamond studded gold locket, which were to be put on a tray in Chas. Hartdegen & Co.'s store, a well dressed man entered, and as his eyes fell upon the array of lockets he exclaimed: "Those are just what I came in to see," and at once began to inspect them. After looking over the stock a few moments he left, saying: "I guess I don't see anything to suit me."

An instant later it was discovered that a valuable three-stone diamond locket was missing. In another instant Mr. Hartdegen had put on his hat and coat and gone into the street to look for the fellow. Glancing into W. T. Rae & Co.'s jewelry store at Broad and Cedar Sts., he saw the suspected man at the counter looking at a trayful of diamond lockets. Waiting until he came out Mr. Hartdegen seized him and took him back to his store and accused him of the theft of the missing locket. He made an indignant denial and told his captors to search him. This was accordingly done, and as nothing but two pennies was found in his pockets, he was allowed to go.

About 6 o'clock a more thorough search was made for the missing locket, and it was found on a table in the store which contained goods of an entirely different character, and where, it is now believed, the thief adroitly tossed it as he was being led back to the rear of the store to be searched.

Glickauf & Newhouse, 86 State St., Chicago, recently invested to advantage a large sum of money in lathes and are giving their customers the benefit of the advantages accruing from their large purchases. It is noticeable that their shipping tables are laden with lathes and an inspection of box markings shows the distribution to be wide, addresses including States all the way from Massachusetts to Mexico. The Moseley is a prominent specialty. Correspondence on the lathe business is brisk and constantly increasing.

## Engravers' Type.

A Rubber Type in new styles specially adapted to Engravers' use. Seven different sizes now ready.

*Minnie S. Foster*  
*Sir Walter Scott.*

Does away with all tracing. Letters are stamped upon the article in clear cut script or old English.

The outline can readily be engraved by even the apprentice.

Type made on new principle, bevel edged; alignment guaranteed.

Every Engraver should have it. Write for particulars.

WM. H. DIETZ,  
117 Dearborn Street, Chicago.



## OPTICIANS' SCHOOL.

If you want a GOOD ROOF over your head, come to our school. We want EARNEST STUDENTS, leave the rest to us, we do not want diploma hunters.

The Chicago Ophthalmic College and Hospital,

H. M. MARTIN, M. D., PRESIDENT. 607 VAN BUREN ST, CHICAGO.

Being the oldest and most favorably known College of Theoretical and Applied Ophthalmic Optics in America, having more thoroughly qualified opticians in the field than all other so-called schools combined.

## REED & BARTON,

SILVERSMITHS,

MANUFACTURERS OF

STERLING SILVER *and* SILVER PLATED WARE.

SALESROOMS:

37 Union Square, New York.

34-36 WASHINGTON STREET,

Venetian Building, Chicago.

FACTORIES, TAUNTON, MASS.



# "Best" Eye Glasses.

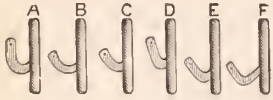

The "BEST" Guard embodies some new features of great value. The lower part is rigid, the upper part is flexible. Made in both shell and cork. Must be seen to be appreciated.

Sample Eyeglass Frame, in 10k. gold.	- -	\$2.90
" " " in Steel or Nickel.	-	.35
Sample Pair of 10k. Gold Guards.	-	.85
" " of Nickel Guards.	-	.15

**Geneva Optical Company,**  
69 WASHINGTON STREET,  
CHICAGO.

## Indianapolis.

E. C. Miller spent last week at his farm in Ohio.

Horace A. Comstock has returned from Tennessee.

Huntington, Ind., has a new wholesale jewelry house, with Olney Grafton at its head.

Owing to financial embarrassment, John Routh, Sellersberg, Ind., has discontinued business.

Wait M. Heaton, of Heaton, Sims & Co., started last week for California on a pleasure trip.

Last week Chas. W. Lauer finished a satisfactory Indiana trip for Baldwin, Miller & Co.

J. E. Druley, jeweler, Memphis, Tenn.,

**THE PLANCHAMP & BECKER CO**  
Makers and Repairers of  
**WATCH CASES,**  
Gold and Silver Plating—  
—of Watch Cases a Specialty.  
UNEXCELLED FACILITIES.  
63 and 65 East Washington St., Chicago.

recently married a Wabash, Ind., lady, Miss Mollie Underdown.

Geo. B. Barns, proprietor of the United States Supply Co., a jewelry instalment house, has closed out his business and removed from the city.

Tom F. Cahill, Spencer, Ind.; L. J. Small, Carmel, Ind.; and A. C. Pilkenton, Fortville, Ind., were among the buyers in town last week.

Two young colored women called at M. T. Campbell's store, 134 Massachusetts Ave., last week, and asked to see some rings. They left without making any purchase. Shortly afterward Mr. Campbell learned that one of the rings was missing. The women were found and arrested.

Traveling men were not very numerous in Indianapolis last week. Among the few were: Louis Melcher, Chicago Case Mfg. Co.; Millard Veit, Marx, Veit & Co.; H. Bloch, Mathews & Willard Mfg. Co.; Chas. B. Barker; G. A. Jewett, New Haven Clock Co.; C. B. Bartlett, Whiting Mfg. Co.; A. Peabody, John S. Jepson, Byron L. Strasburger & Co.; representative of Peckham Seamless Ring Mfg. Co.; C. W. Battey, Waite, Mathewson & Co.

... THE ...

# American Horological Institute

AND TECHNICAL SCHOOL OF LANCASTER, PA.,  
LATE OF PHILADELPHIA, PA.,

A Trade School where Watchmaking is taught practically. We do not manufacture

☀ BICYCLES OR DYNAMOS ☀

at this institute. We confine our work strictly to WATCH WORK and its kindred branches, which include

≡ Engraving, Jewelry Work and Optics ≡

One tuition pays for all the branches. We do not have boy instructors at this institute, all men of years of experience. Each department has its separate instructor. Our institute is open for inspection. We kindly invite you to visit us and inspect our school modes of giving instruction and the progress that our students make by giving them practical instruction.

**THOMAS PENDERGAST,**  
PROPRIETOR AND MANAGER.

## PATENT FIBRE-FACED HAMMERS.

5 oz. for Watchmakers.  
10 oz. for Manufacturing Jewelers.  
Price 50 Cents Each.

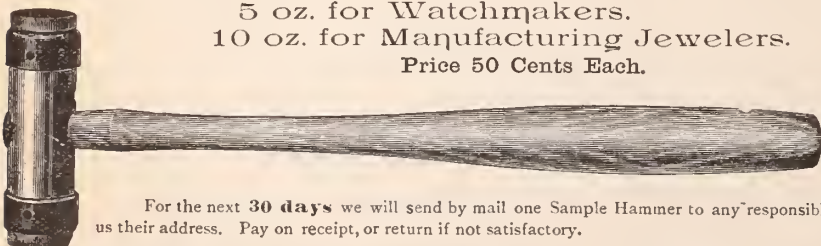

For the next 30 days we will send by mail one Sample Hammer to any responsible firm, giving us their address. Pay on receipt, or return if not satisfactory.

**W. W. OLIVER, Sole Manufacturer, - Buffalo, N. Y.**

Send for our No. 10 Catalogue.

**CHAS. H. PFEIL,**  
MANUFACTURING JEWELER.  
Diamond Work a Specialty.

BEST of Workmen.  
BEST Design Work.  
GUARANTEED Workmanship.

Send a trial order and be convinced.  
182 State St., Chicago.

**HUGO MUELLER,**  
182 State St., (Room 70,) Chicago.

FINE WATCH REPAIRING  
IN ALL ITS BRANCHES.

Work for the trade promptly executed by skilled workmen.

**PARSONS : SCHOOL**  
—FOR—  
**WATCHMAKERS,**  
PEORIA, - - - ILL.

Send for Circular and Terms.

**PARSONS & CO.**

WATCH CASE MAKERS AND REPAIRERS.  
**BOLSTAD MANUFACTURING**  
**AND PLATING CO.,**  
GOLD AND SILVER PLATERS.  
DESIGNING AND ENGRAVING.  
170 Madison Street, - - CHICAGO.

**ELGIN HOROLOGICAL SCHOOL,**  
THOROUGHLY PRACTICAL.  
COMPETENT INSTRUCTORS.  
Send for Prospectus.  
**ELGIN, ILL.**



**Detroit.**

Edward Roehm was ill with the influenza last week.

Elizabeth Petherick has sold to W. W. Petherick, the business of E. J. Fox & Co., 6 E. Larned St. She held chattel mortgages.

Burglars last week effected an entrance to Lee Powellson's jewelry store, Oxford, Mich., and stole \$300 worth of watches and rings.

M. M. Dwilliard and A. S. Bleyer, representing the United States Optical Co., started out last Monday for trips through the west and Michigan.

Fire last week visited Reed City, Mich. Among the losers was H. L. Baker, jeweler. The damage to the stock was between \$1,000 and \$1,500, partly insured. Most of the goods was removed in time.

Daniel W. Kinney, formerly a jeweler and one of West Saginaw's best known citizens, died last week of apoplexy. He was found on the street in an unconscious condition. He leaves a family in comfortable circumstances.

The police last week arrested Herman Krahn, a watchmaker and former Gratiot Ave. jeweler, for receiving stolen property. Krahn admitted that he had pawned several watches and chains, but claimed that they were part of his old stock.

Business picked up some with the jobbers last week. The following Michigan country jewelers were here: J. S. McGlaucklan, Wyandotte; G. W. Stephens, Port Huron; W. H. Baxter, Birmingham; H. Loss, Wayne; C. G. Draper, Plymouth; Fred Grimm, Mt. Clemens, and Geo. H. Hebblewhite, Armada.

W. H. Grenfell, agent for a firm of plated ware manufacturers, will open a jobbing office here shortly. He covers Michigan, Ohio, Indiana and Illinois. Mr. Grenfell is one of five stockholders in a new concern

to be known as the Etna Silver Plate Co., which will be organized in Chicago about March 1st. They will manufacture a line of silver plated novelties, besides doing a jobbing business.

**Minneapolis and St. Paul.**

Eric Anderson, Wheaton, Minn., has sold out his business.

H. P. Marx, Shakopee, Minn., accompanied by his bride, visited friends in the Twin Cities the past week.

M. L. Finkelstein, St. Paul, has opened up in business at 327 Jackson St., in the store formerly occupied by J. E. Ingham, jeweler.

S. P. Sandberg, Red Wing, Minn., was in Minneapolis last week, purchasing an outfit of tools, and will open a repair shop in that city.

S. H. Clausin, of S. H. Clausin & Co., Minneapolis, started last week on a trip to the Pacific coast. He will take in the Mid-Winter Fair during his trip.

Eichberg & Co., New York, brought suit in the District Court last week against Harry F. Legg to recover \$1,066.04 on certain promissory notes, past due.

P. F. Egan, St. Paul, has discontinued his business, and during the past week stored his stock and fixtures. Judgment was entered against Mr. Egan last week for \$30.00.

W. E. Roundy, who was arrested a few weeks ago, charged with stealing watches and jewelry from the Reed & de Mars Jewelry Mfg. Co., Minneapolis, in whose employ he was at the time, and who was indicted on a charge of grand larceny last week, pleaded guilty to the charge, and was sentenced to State prison at hard labor for eight months.

The Reed & de Mars Jewelry Mfg. Co., Minneapolis, will during the first week in

March, remove from their present quarters, 219 Nicollet Ave., where they have been located for the past twelve years, into the Lumber Exchange building, corner Hennepin Ave. and 5th St., they having leased a large room on the fourth floor for a term of years. When located in their new quarters they will have one of the finest salesrooms in the northwest.

**Kansas City.**

The Jaccard Watch and Jewelry Co. have made quite a hit with a lot of little pins in the shape of pennants bearing college colors.

Fred L. Merry, a son of Charles L. Merry, manager of the Kansas City branch of the Julius King Optical Co., has gone on the road for that company.

Burglars broke into L. C. Welch & Co.'s jewelry store, Ozark, Mo., a few nights ago, and made away with 52 watches and \$9 in money. It is supposed to have been the work of burglars who lived there, but no arrests have been made.

The will of the late Clements Altman, father of Frank G. Altman and Clements B. Altman, the Main St. jewelers, was offered for probate a few days ago. All the property, valued at \$20,000, is bequeathed to the widow, Mrs. Wilhelmina Altman, and she is made executrix.

A bold robber rang the door bell at the home of Eleazar Hart, of the Hart Jewelry Co., Tuesday evening. Philip Hart, aged 70 years, father of E. Hart, answered the call. "I am an assistant to Dr. Copeland, and was sent to see Mrs. Hart." Dr. Cordier had been treating Mrs. Philip Hart, and the old gentleman, not noticing that the man made a mistake in the physician's name, ushered the stranger in. When in the hall the man drew a knife and demanded money. Mr. Hart ran into a room calling "murder!" The robber fled and though several shots were fired at him he escaped.

**The Wadsworth Watch Case Co.**



Filled



Cases.



General Offices,  
**NEWPORT, KY.**

Chicago Office,  
**COLUMBUS BUILDING.**



The Jaccard Watch & Jewelry Co., in competition with eastern manufacturers, have secured a contract for 1,000 silver plated trays for the Ferd. Heim Brewing Co. They would retail at \$6 apiece and will bear the trade mark of the brewery. They will be used for advertising purposes, and will be given away to customers.

Maurice Bradford, formerly clerk for the Hart Jewelry Co., was arrested a few days ago while trying to dispose of some silverware. An investigation showed that he had been stealing from his employers. Friends promised to make good the amount he has stolen, which so far as known will not exceed \$100, and Mr. Hart will not prosecute him.

The annual meeting of the Jaccard Watch & Jewelry Co. was held Feb. 23. Eugene G. E. Jaccard was re-elected president; W. S. Simpson, of St. Louis, vice-president; Walter M. Jaccard, secretary and R. J. Gilbert, treasurer. D. C. Jaccard, of the Mermod & Jaccard Jewelry Co., and W. S. Simpson, both of St. Louis, were here in attendance at the meeting.

### Connecticut.

A. L. Sercomb, the Chicago representative of the Meriden Britannia Co., has been in Meriden for a few days.

President Watson J. Miller, of the Derby Silver Co., was elected Feb. 22d a director of the Derby Building and Lumber Co.

The spoon factory of Bristol has closed down its plant. The officers of the concern are unable to say when work in the factory will be resumed.

The Wilcox Silver Plate Co. have made a contract with the managers of the Yale Athletic Association to furnish 21 prize cups for the indoor Winter games which will take place in the Yale gymnasium next month.

The Waterbury Watch Co.'s output last year was within 10 per cent. of that of the previous year. The company are now busily replenishing the stock which has been so greatly reduced by their heavy fall trade.

F. A. Browne, who has been introducing the Waterbury watch to the natives of the Land of Fowers, has sent home from Florida a box of live chameleons which are on exhibition in the window of Lake, Strobel & Co., jewelers.

The administrator of the estate of the late Isaac C. Lewis, ex-president of the Meriden Britannia Co., Friday sent out checks to relatives of the deceased aggregating \$25,000. Mr. Lewis left no will, but he left instructions to his family to distribute this sum.

Henry E. Biggins' new silver goods factory in Wallingford will be commenced as soon as the snow disappears. The name of the new concern is the Wallingford Hollow Ware and Silver Plating Co. Operations will begin April 1. Henry B. Hall, a successful salesman, has been engaged by Henry E. Biggins to look after the sales department of the new business.

Hon. Samuel Simpson, president of Simpson, Hall, Miller & Co., is no longer able to go out of his house. His sufferings are very great, which can only end in death. The cancer has eaten out a large cavity near the temple. It has been several weeks since he has been able to ride out. His condition Wednesday was more favorable, although it is still critical.

Capewell, the jeweler, of West Winsted, has designed a souvenir spoon that will have a National, as well as a local demand. In the bowl is a beautiful etching of the old Seabury House, in Woodbury, Conn., where Samuel Seabury was chosen as first Episcopalian bishop in America. On the handle is an etching of Bishop Seabury. The spoon is gotten up in the old colonial style representative of his time.

The Standard Electric Time Co., New Haven, have reduced their capital stock from \$28,750 to \$14,375, and the number of shares from 1,150 to 575. The directors of the company are: Frank E. Morgan, ex-secretary of the New Haven Clock Co.; C. D. Warner, manager of the company; Wm. R. Tyler, a wealthy New Haven resident, and Allen W. Paige, ex-speaker of the Connecticut House of Representatives.

George H. Wilcox, Charles Parker, N. L. Bradley and William F. Rockwell have just been elected members of the board of directors of the Meriden Republican Publishing Co.; Wm. F. Rockwell was elected president. D. B. Hamilton, of Waterbury, and George H. Wilcox, Charles Parker, E. B. Cowles and N. L. Bradley, of Meriden, have been elected directors of the Meriden Fire Insurance Co.; N. L. Bradley was elected vice-president

HOAX—Talk about making calls. I made one last night that cost me \$95.

JOAX—How was that? Have to buy an engagement ring?

HOAX—No; I called with four kings and the other fellow had four aces.—*Philadelphia Record.*

"Hit am er great t'ing ter be consistent, but not too much so," remarked Uncle Eben.

"De clock in de jeweler's sign dat allus pints ter twenty minutes past eight is one ob de mos' consistent t'ings what is."—*Washington Star.*

### ZARA'S EARRINGS.

[FROM THE SPANISH.]

MY earrings! my earrings! they've dropped into the well.

And what to say to Muca, I cannot, cannot tell— 'Twas thus, Granada's fountain by, spoke Albuarez daughter—

The well is deep—far down they lie, beneath the cold, blue water:

To me did Muca give them when he spoke his sad farewell.

And what to say when he comes back, alas! I cannot tell.

My earrings! my earrings!—They were pearls in silver set,

That when my Moor was far away, I ne'er should him forget;

That I ne'er to other tongues should list, nor smile on other's tale,

But remember he my lips had kissed, pure as those earrings pale.

When he comes back, and hears that I have dropped them in the well,

Oh, what will Muca think of me? I cannot, cannot tell.

My earrings! my earrings!—He'll say they should have been,

Not of pearl and of silver, but of gold and glittering sheen.

Of jasper and of onyx, and of diamond shining clear, Changing to the changing light, with radiance insincere:

That changeful mind unchanging gems are not befitting well.

This will he think—and what to say, alas! I cannot tell.

He'll think when I to market went I loitered by the way;

He'll think a willing ear I lent to all the lad might say; He'll think some other lover's hand, among my tresses noosed.

From the ears where he had placed them my rings of pearls unloosed;

He'll think when I was sporting so beside this marble well

My pearls fell in—and what to say, alas! I cannot tell.

He'll say I am a woman, and we are all the same; He'll say I loved when he was here to whisper of his flame—

But when he went to Tunis, my virgin troth had broken.

And thought no more of Muca, and cared not for his token.

My earrings! my earrings! Oh, luckless, luckless well!—

For what to say to Muca, alas! I cannot tell.

I'll tell the truth to Muca—and I hope he will believe— That I thought of him at morning and I thought of him at eve;

That musing on my lover, when down the sun was gone,

His earrings in my hand I held, by the fountain all alone;

And that my mind was o'er the sea when from my hand they fell,

And that deep his love lies in my heart, as they lie in the well.—*Baltimore American.*

Charles E. Morley, the newly elected town clerk, of Jordan, N. Y., has taken possession of the office and has removed the same to his jewelry store.

The Roy Watch Case Co. Cases  
assay among the highest.



**Queries by Circular Readers.**

*Editor of THE JEWELERS' CIRCULAR:*

Can you tell me who the maker of the Shakespeare souvenir after dinner coffee spoon is? T. V. D.

ANSWER: J. A. Merrill & Co., Portland, Me., are the makers of the Shakespeare souvenir spoon.

*Editor of THE JEWELERS' CIRCULAR:*

Will you inform me or give me the address of the firm having the agency of the "Lange" watch, manufactured in Dresden, Germany?

ALEX. CALENELET.

ANSWER: Chas. W. Schumann, 24 John St., New York, is sole agent for the A. Lange watch.

*Editor of THE JEWELERS' CIRCULAR:*

In your next issue would you kindly inform me the kind of varnish or preparation that is put on silverware to prevent tarnishing. It is used in some of the factories. How is it prepared, what are the ingredients, and how is it applied? S. J. RUGG.

ANSWER: The substance referred to is a secret preparation. Write to Celluloid Zapon Co., 41 Barclay St., New York.

*Editor of THE JEWELERS' CIRCULAR:*

I would like to get a book that would give me a good idea how to make a simple little engine; if you will please write me where I can get it, I will be obliged to you. R. M. FELSON.

ANSWER: Write to the Masonic Publishing & Supply Co., 21 Park Row, New York, and they will furnish you the information desired.

*Editor of THE JEWELERS' CIRCULAR:*

Can you inform me how to resilver a small mirror? H. E. PINE.

ANSWER:—The editor is in doubt whether its esteemed correspondent means simply an ordinary mirror, or one for optical purposes; the processes differ widely. Faraday in his work on chemical manipulations says:

"A piece of clean, smooth tin foil, free from holes, is to be cut to the same size as the glass, and laid upon a couple of sheets of filtering or blotting paper folded into quarters. A little mercury is to be placed on the foil, and rubbed over it with a hare's foot, or with a ball of cotton slightly greased with tallow, until the whole of the upper surface of the leaf is amalgamated and bright. More mercury is then to be added, until the quantity is such as to float over the tinfoil. A piece of clean writing paper, with smooth edges, is to be laid upon the mercury, and then the glass surface, previously well cleaned, is to be applied to the paper. The paper is to be drawn out from between the mercury and the glass, while a slight but steady pressure is to be applied to the latter. As the paper recedes it carries out all air and dirt with it from between the glass and the metal, which comes into perfect contact.

"The mirror is now made, and may be used for an experiment; but there is still much more mercury present than is required

to make the definite and hard amalgam of tin constituting the usual reflecting surface. If it be desired to remove this excess, the newly formed mirror must be put under the pressure of a flat board, in a slightly inclined position, and loaded with weights. The success of this operation will be found to depend chiefly upon the care exercised in cleaning the glass."

**LEGENDS OF GEMS.**

BY FRANK SHELLEY.

Gilt edged; bound in leather; a perfect specimen of the printer's and binder's art. Should be in every jeweler's library. Price, \$1.00. For sale by

THE JEWELER'S CIRCULAR PUB CO.



**OPPENHEIMER BROS. & VEITH,  
WATCHES AND**

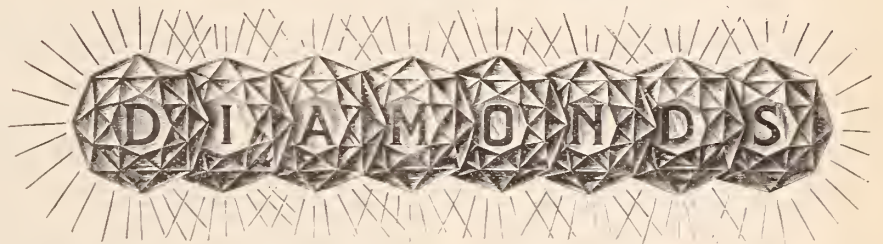

**DUEBER CASES. HAMPDEN MOVEMENTS.**

AMSTERDAM, HOLLAND, 2 TULPSTRAAT.

LONDON, ENGL., 28 HOLBORN VIAD CT.

NEW YORK, 35 MAIDEN LANE.



FULL SIZE NEW ROCOCO.

**THOMAS W. LIND, Manufacturer of Jewelers' Findings,**

67 FRIENDSHIP STREET, PROVIDENCE, R. I.

Call or send for samples of my New ROCOCO PATTERNS, for Picture Frames, Cane Heads, Whips, Boxes, Napkin Rings, etc.

Large Assortment of TRIMMINGS for Millinery Ornaments, Scarf Pins, etc



**DIAMONDS.****Wm. S. Hedges & Co.,**

Importers of Diamonds,

And Manufacturers of DIAMOND JEWELRY.

170 Broadway, New York.

22 Holborn Viaduct, London.

**R. A. KIPLING,**

Importer of

**PRECIOUS STONES,**

21 &amp; 23 Maiden Lane,

19, RUE DROUOT,  
PARIS.

New York.

**CALIFORNIA  
MIDWINTER FAIR.****Novelties** 

IN

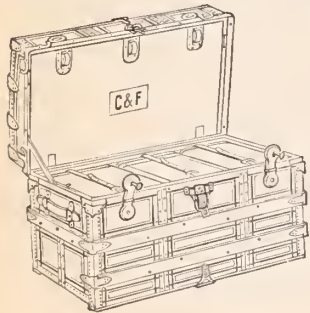
Sterling and Plated  
Souvenir Spoons, Silver  
Plated Trays, Match Boxes,  
Paperweights, Charms, Sleeve  
Buttons, Rings, etc., etc.**Julius Eichenberg,**174 Weybosset Street,  
Providence, R. I.**CROUCH & FITZGERALD.**Jewelry Trunks  
and Cases  
161Broadway,  
Bet. Cortlandt and  
Liberty Sts.,  
688 B'way,  
701 6th Ave.,  
NEW YORK.**Alfred H. Smith & Co.,**IMPORTERS**DIAMONDS**

AND

PRECIOUS STONES,

182 BROADWAY, COR. JOHN STREET

NEW YORK.

22 Holborn Viaduct, London, E. C.

No jeweler or watch repairer should be without a copy of "WORKSHOP NOTES," a new and very useful book for the workshop. Send for circular containing a complete index of the book, and judge of its merits for yourself.

**FANCY DIALS TO FIT AMERICAN WATCHES.**  
**\$6.00 per doz. IN FLAT SECONDS.**  
**\$7.20 per doz. IN PRESSED SECONDS**

Jobbers, Importers and Retailers generally, will be rebated by sending to us any Dials of our make which they may have on hand.

O'HARA WALTHAM DIAL CO., Waltham, Mass.

**HENRY ABBOTT,**

MANUFACTURER OF

**Stem-Winding Attachments  
FOR WATCHES,**

No. 2 Maiden Lane, NEW YORK.

**Correspondence.**

NEW YORK, Feb. 16, 1894.

Editor of THE JEWELERS' CIRCULAR:

I enclose herewith a circular of queries that I am very desirous of having answered to assist in carrying out an investigation in regard to the locations, yield and proper protection of fresh water pearl fisheries in the United States. If you will kindly give this matter place in the next issue of your CIRCULAR you will greatly oblige,

Very truly yours,

GEORGE F. KUNZ.

All correspondence on this subject should be addressed to me as follows: George F. Kunz, care United States' Commission of Fish and Fisheries, Washington, D. C.

## LIST OF QUESTIONS.

## THE PEARL-BEARING MUSSELS:

1. Nature of stream in which found; kind of bottom; character of water.
2. Geological character of the district as to rock, soil, etc.
3. General abundance of mussels.
4. Size, shape and position of the mussel beds.
5. Local names of mussels.
6. Habits of mussels.
7. Enemies and fatalities to which mussels are exposed; nature and extent of destruction by muskrats, hogs, freshets, etc.
8. Size, shape and color of mussels.
9. Species of mussels in which pearls are most common.
10. Proportion of mussels in which pearls occur.
11. Sizes, or other peculiarities, of shells in which pearls are found.

## THE PEARLS:

12. Nature and origin of pearls.
13. Position in mussel
14. Size, shape and color of pearls
15. Relative value of pearls of different sizes, shapes and colors.
16. Markets for pearls.
17. Prices for pearls.

## THE FISHERY:

18. Method of taking the mussels.
19. Description of apparatus used in taking mussels and in opening the shells.
20. Methods of extracting the pearls.
21. Treatment of pearls when found.
22. Utilization of mussels after extraction of pearls or after opening.
23. Principal occupations of mussel fishermen.
24. Statistics of fishery in 1893: Fishermen—number; boats—number; value; apparatus—number; value; pearls—number; value.
25. Statistics, complete or partial, for previous years.
26. Period when pearl fishing was of greatest importance in district.
27. History of origin and growth of fishery.
28. Exhaustion of mussel beds; causes; rapidity.
29. Do exhausted beds become replenished, and in what time?
30. Is State protection of beds desirable or necessary?

What is the difference between a jailor and a watchmaker?—One watches cells and the other sells watches.—*New York Mail and Express.*

**ROY****The Roy Watch Case Co. Cases are  
Sold only through Jobbers.****ROY**



**Trade Gossip.**

The two illustrated photogravure sheets showing latest designs in diamond goods and badges that are being sent out to the better class of trade by the Juergens & Andersen Co., 125 State St., Chicago, are artistic in designs shown, and of real value to all dealers in diamond goods.

Chamois skins may be numbered among the absolute necessities to all jewelers. Among the best and cheapest chamois skins in the market, are those manufactured by Geo. H. Taylor. The trade will therefore be pleased to learn that Geo. C. Taylor Havemeyer Building, 26 Cortlandt St., New York, the agent for these skins, sells them by the kip or in small quantities. He will furnish particulars upon application.

*The Scientific American* has the following to say of Martin Brunor's book, *The Practical Electroplater*:

"This work has the advantage over several other volumes published in the same line in being largely the result of the personal researches and experience of the author, many of the processes described being here for the first time given to the public. In Paris, as well as in this country, the author addressed himself to mastering all the details of electroplating as exemplified in the workshop rather than as theoretically set forth. It is, therefore, a book for practical men, giving some 200 articles and formulas for solutions, describing processes for gilding with and without a battery, for oxidizing, fire gilding, etc."

A thing that's growing in demand is the new swell end eye wire embodied by the Spencer Optical Mfg. Co., on their gold spectacles and eyeglasses, adding beauty and great strength, it being all one piece and rolled on by newly constructed machinery. The more the trade see it, the better they seem to like it, as a gold frame can be made light and very strong by this new patented process controlled by the Spencea Company. The March class in Practical Optics of the Spencer Optical Institute will assemble March 6th at 6.30 p. m. Dr. H. A. Heath as demonstrator and instructor will use the completed refraction board which has been improved since the last class.

Neat little yearly calendars made to fit inside of all sized watch cases, have been presented in quantities to the trade with the compliments of the Crescent Watch Case Co., Newark, N. J. These make a useful present for the retailer to give his patrons, and advertise both his business and the celebrated "Unequaled Crescent Case." This company keep up a standard of quality in their product which enables the legitimate jeweler to feel that he can safely add his guarantee to their own, with the assurance that it will be made good should occasion require. They make no cheap rolled or electro-plated cases, but aim to make a case which will be a credit to the maker and retailer. Their trade mark is in every case whether silver or filled.

ESTABLISHED 50 YEARS.

**RANDEL, BAREMORE & BILLINGS,**

IMPORTERS OF

**DIAMONDS,**

AND OTHER PRECIOUS STONES.

**FINE PEARLS A SPECIALTY.**

MANUFACTURERS OF

**DIAMOND JEWELRY,**

IN THE LATEST DESIGNS.

Diamonds Recut in Modern Styles or Repaired on Premises

58 Nassau Street,  
29 Maiden Lane  
NEW YORK.

1 Tulp Straat,  
AMSTERDAM.

1 St. Andrews St.,  
Holborn Circus,  
LONDON, E. C.



TRADE MARK.

ESTABLISHED 1841.

**CARTER, SLOAN & CO.,**

**MANUFACTURERS OF GOLD JEWELRY,**

No 15 MAIDEN LANE.

NEW YORK.

A. CARTER, JR.  
A. K. SLOAN.  
C. E. HASTINGS.

GEO. R. HOWE.  
WM. T. CARTER.  
WM. T. GOUGH.

FACTORY, NEWARK, N. J.



**JOHN N. DISSELKOEN,**  
Cutter and Importer of  
**DIAMONDS**

FACTORY,  
76 LANGBLEEKERSPAD,  
AMSTERDAM.

19 East 16th St.,  
NEW YORK.

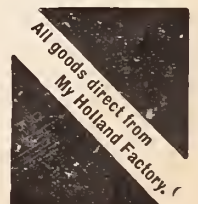





**Our Traveling Representatives**

Traveling representatives may consider these columns open for the publication of any news or items of interest regarding themselves or their conferees.

**E. E. SPAULDING**, who formerly looked after northwestern territory for Lapp & Flershem, is to connect himself with F. W. Spaulding, a brother, of Minneapolis, Minn.

Mr. Hall, traveling man for the Bristol spoon shop has resigned, and Edwin S. Robbins, of Waterbury, traveling man for the E. N. Welch Mfg. Co., will do the work for both companies.

Eastern jobbers and manufacturers represented in the Twin Cities the past week were: A. C. Becken; Benj. Allen & Co. by A. J. Chase; Waterbury Clock Co., by Fred L. Pettee; the Keystone Watch Case Co., by H. M. Carle; Albert Berger & Co., by H. Somborn.

Travelers calling upon Davenport, Ia., jewelers during the past week were: S. E. Bolles, M. B. Bryant & Co.; M. Hollister, Hayden W. Wheeler & Co.; A. H. Clinger, Wm. Rogers Mfg. Co.; C. Jeanneret, Juergens & Andersen Co.; T. A. Beard, F. L. Shepardson & Co.; A. L. Perkins, St. Louis Silver Co.

Arthur J. Perry left Monday for Minnesota, western Wisconsin, North Dakota, and possibly Montana, in the interests of Lapp & Flershem. Mr. Perry represented M. A. Mead & Co. the past seven years, and is one of the best known travelers in the country at large. He has passed a lifetime in the jewelry trade and is an energetic, tireless worker. Mr. Perry has with him a most complete line from the extensive stock of the "Busiest House in America."

Traveling men who visited Pittsburgh last week were: Tom Davies, Middletown Plate Co.; D. A. Skutch, Waterbury Clock Co.; Dave Kaiser, Lewis, Kaiser & Luthy; Mr. Platt, Foster & Bailey; Samuel Hughes, Shafer & Douglas; W. G. Hamilton, Meriden Bronze Co.; J. F. Granberry, Reeves & Sillocks; M. Coughlin, William Link; H. Grabowski, Dattelbaum & Friedman; E. L. Brown, Manasseh Levy; E. H. Smith, Holmes & Edwards Silver Co.; A. A. Wood, Howard Sterling Co.; and F. A. Frey.

Travelers attending religiously to duty in these early days of Lent were noticed in Chicago jobbing houses last week as follows: Wm. H. Allardyce, Ed. Todd & Co.; Geo. L. Paine, E. I. Franklin & Co.; A. M. Leibman, E. P. Reichhelm & Co.; Louis E. Fay, Kirby, Mowry & Co.; A. Peabody; Monroe Engelsman, Maurice Weil; C. A. Marsh, Marsh & Bigney; Richard Robinson, Richard Robinson & Co.; E. P. Tiffany, F. H. Sadler & Co.; M. Rosenberger, A. Wallach & Co.; Geo. B. Caldwell, Plainville Stock Co.; A. D. Engelsman, Vve. L. B. Citroen & Co.; E. L. Mumford, Waite, Thresher & Co.

Members of the traveling fraternity visiting Syracuse, N. Y., the past week were: Mr. Smith, The Holmes & Edwards Silver Co.; J. Goldberg; H. C. Schwartz, Krementz & Co.; Mr. Barton, R. Wallace & Sons Mfg. Co.; E. D. Wetton, C. Dorflinger & Sons; T. G. Walpuski, American Morocco Case Co.; C. H. Carpenter, Parsons & Greene Co.; T. Price, John G. Schanbacher & Co.; F. C. Winship, T. B. Clark & Co.; A. Rutherford, Kirby, Mowry & Co.; C. C. Rosenberg, Henry Terhune & Son; Ernest L. Meyer, Westminster Candle Co.; Mr. Neely, Alfred H. Smith & Co.; L. E. Myers; Mr. Brown, Wilcox Silver Plate Co.; Fred S. Eaton, J. T. Scott & Co.; Milton Holly, Montgomery & Co.; Gus W. Strandberg, E. L. Spencer & Co.; M. L. Hammel, Keller, Ettinger & Fink; F. S. Sherry, Jos. Fahys & Co.; E. L. Mumford, Waite, Thresher Co.; O. S. Clark, C. G. Alford & Co.; Mr. Braillard, Braillard & Pfingston; W. R. Washburne.

The following traveling salesmen passed through Detroit last week: Max Stein, Martin Metzger & Co.; William Matschke, Kuhn, Dorflinger & Co.; M. Friedman; Edwin S. Robbins, Bristol Brass & Clock Co.; William Deitz, L. Combremont; F. Cocks, E. E. Kipling; C. F. Friedholdt, The Springfels Mfg. Co.; Mr. Marsh, Marsh & Bigney; L. H. Smith, Bippart & Co.; Edgar L. Brown, Manasseh Levy, Jean Holbrook, F. W. Smith; Mr. Davidson, Harrison Bros. & Howson; H. A. Bliss, Krementz & Co.; John W. Case, H. F. Carpenter; C. M. Dillon, Meriden Cutlery Co., T. G. Walpuski, American Morocco Case Co.; W. H. Allardyce, Ed. Todd & Co.; C. R. Fairchild, Leroy W. Fairchild & Co.; Frank C. Alden, Hayden W. Wheeler & Co.; W. T. Gough, Carter, Sloan & Co.; A. M. Leibman, E. P. Reichhelm & Co.; Thos. E. Rogers, Hayes Bros.; Henry Osborne, Whiting Mfg. Co.; H. Weinrich, J. A. Schwartz & Co.; Charles Seabury, Rogers & Bro.; and W. P. Hanford, Roseman & Levy.

### Springfield, Mass.

E. M. Beckwith, who has run a jewelry store in Florence for some years, has closed it out and has removed to Torrington, Conn.

Charles S. Saxton, the ex-jeweler, whose troubles with his wife caused so much talk last year, was granted a conditional divorce from her last week, on the ground of adultery and habitual inebriety from the use of opium and other drugs.

The following traveling men were in town within the past week: Mr. Wolfsheim, L. Wolfsheim & Co.; E. A. Bigelow, Hayden Mfg. Co.; Charles H. Barrey, Middletown Plate Co.; H. P. Barker, Meriden Britannia Co.; P. E. Baldwin, Acme Silver Plate Co.; N. B. Etyngge, L. Sauter & Co.; and Joseph Friedlander, Joseph Friedlander & Bro.

W. I. Dewey, engraver for F. A. Hubbard, has retired on account of ill-health and will engage in some other business. He has been succeeded by F. D. Pridham, of Torquay, England, but recently of Boston, where he was employed by N. G. Wood & Son. Mr. Pridham's father is the oldest established jeweler in Torquay and the son at one time was employed by Charles Packard & Son, London.

The concluding act in the drama attending the robbery of H. C. Barnum's jewelry trunk was played in this city last week, when David B. Ahgren and William Virtue, the two men arrested as accessories to Cummings were released. The police are now just where they started from, and while they will not give up the attempt to capture the thief, there is little chance of their having any success. At the hearing last week Virtue was prepared to prove an elaborate alibi, and for this purpose engaged as an attorney Luther Shafer, the Mayor of Rutherford, N. J.

### Louisville.

The Waterbury Watch Co. were given a judgment for \$53.10 against James K. Sharp, in the Circuit Court at Jeffersonville last week.

Chas. Morris, the crook who threw pepper into the eyes of Geo. Boergershausen, and then grabbed a handful of diamonds, pleaded guilty last week and by consent was given a term of two years in the penitentiary.

A bold attempt to rob the jewelry store of Henry Wolf was made last Sunday morning by unknown parties. A quantity of jewelry and watches is usually kept in the show windows. The burglars broke the plate-glass window, which was valued at \$50, and finding nothing in the window left without doing further damage.

The best Trade use the **ROY** Watch Case Co. Cases.



## News Gleanings.

L. B. Hilborn, optician, has located in Madison, Wis.

Richard Wegner has bought out Eric Anderson, Wheaton, Minn.

G. L. Russell has bought the Case jewelry stock in Greeley Center, Ia.

The Shea Plating & Mfg. Co. will remove from Cleveland, O., to Macon, Ga.

The store of Moses Kohn, Austin, Tex., was damaged by fire a few days ago.

S. D. Lyon will open a new jewelry store in the McAlpin block, Morristown, N. J.

Thomas B. Miller, Berlin, Pa., expects to remove to Allegheny, Pa., in the Spring.

A. Louis, Thornton, Tex., lost about \$700 by fire last week. His insurance is \$500.

J. Richard Cressman, Allentown, Pa., will remove March 1st to Sellersville, Pa.

Roy O'Neill has purchased the business in Zanesville, O., recently assigned by Mrs. Tanner.

W. D. Middaugh, of Grand Rapids, Mich., claims to have opened an opal mine in Washington.

Messrs. Mason and Callstrom have gone into the jewelry business on Bridge St., Morrisville, N. J.

A. W. Flye, jeweler, Gloucester, Mass., has leased a store in Tappan's block, and will soon move there.

S. C. Coyle will open a jewelry store at the corner of Walnut St. and the B. & O. Railroad, McKeesport, Pa.

C. F. Lefmann, of Michigan City, Ind., has been trying to procure a suitable location to open a jewelry store.

Bids will be received till March 12 for the placing of a clock in the tower of the new court house in Hempstead, Tex.

D. F. McErven has moved his family from Charleston, S. C., to Aiken, and he has opened a jewelry store there.

O. C. Deselms, Dunkirk, Ind., is closing out his stock at auction. H. H. Phillips will also dispose of his goods at auction.

The store of J. M. Keling, Weatherford, Tex., was damaged by fire a few days ago, to the extent of \$400; no insurance.

N. L. Marsh, Bellaire, O., will open a branch jewelry store at Sistersville, W. Va., in charge of his brother, Cash Marsh.

The stock of C. E. Cochran, Denver, Col., is ordered to be sold by the District Court, at auction, commencing Feb. 27.

The business of E. M. McCullough, Clarion, Pa., was destroyed by fire last Monday night; loss, \$1,200, insurance \$800.

A. B. & C. W. Dumont, Marion, Ia., have sold their stock of jewelry to J. E. Frantz, who will continue the business at the old stand.

James E. Swartout and Everett T. La France will open a jewelry store at the corner of Railroad Ave. and Water St., Elmira, N. Y.

The building in Worcester, Mass., in which Walter Hildreth had commenced to manufacture shell jewelry was destroyed by fire last week.

Charles B. Wilkens, watchmaker and jeweler, has established a repairing department in Frank H. Wells' store, 337 S. Salina St., Syracuse, N. Y.

Louis Burnett & Co., 516 Edmond St., St. Joseph Mo., are looking for a new location in Felix St. They expect to move about the middle of next month.

Dr. M. Schwab & Son, oculists and opticians, Savannah, Ga., have opened a permanent branch in Wilmington, N. C., with Dr. G. Marcus in charge.

The Elgin National Watch Co. will commence next month on five days a week. For some time past the factory has been running three days a week.

The H. B. Betz Watch & Jewelry Co., of Kentucky, have been granted permission by the Pennsylvania Legislature to open a branch office in the latter State.

The J. C. Herkner Jewelry Co., Grand Rapids, Mich., have filed their annual report as follows: Capital stock, \$50,000; paid in, \$48,000; personal estate, \$70,588; debts, \$28,270; credits, \$12,707.

M. E. Nabstedt, Davenport, Ia., has recently added to his jewelry store an extensive medal making and metal working plant, equipped with machinery of the latest pattern, run by electric motor.

M. Liberman, formerly with Louis Burnett & Co., St. Joseph, Mo., has gone into partnership with S. Libowitz, and the firm will conduct a loan office at 312 Edmond St., and a general repair store under the style of Libowitz & Liberman.

The sheriff a few days ago sold out at auction the stock of Ed Stanton, Riverside, Cal., to satisfy a claim held by J. A. Simms. The stock was bid in by Mr. Simms for the amount of his bill and costs of court and sale, which were \$2,217.

Cameron & Winterhalter, Butte, Mon., whose dissolution was announced in a recent issue of THE CIRCULAR, have been succeeded by Towle & Winterhalter. H. A. Towle is an expert jeweler, and was many years with Hight & Fairfield. Mr. Cameron, who retires, is on his way to South Africa.

Girard's watch case factory in Port Jervis, N. Y., resumed operations some days ago after a vacation extending since before the holidays. This factory heretofore has turned out gold watch cases exclusively, but the new work on which the operatives are engaged is an order for two hundred silver cases.

Frank E. Sargent, 484 Congress St., Portland, Me., placed a lamp in his window last Saturday morning to thaw off the frost. The oil from the lamp overflowed onto a lot of cloth used for decoration which at once took fire. The goods were removed as quickly as possible. The loss was about \$100; covered by insurance.

## Last Week's Arrivals.

The following out-of-town dealers were registered in New York during the past week: J. Adams, Boston, Mass., Grand Union H.; A. Wilson, Boston, Mass., Astor H.; S. Oppenheimer, Kingston, N. Y., Morton H.; H. A. Osgood, Lewiston, Me., Astor H.; J. Clancy, buyer for Pettis D. G. Co., Indianapolis, Ind., 120 Franklin St.; J. R. White, Buffalo, N. Y., Grand Union H.; J. E. Bird, Boston, Mass., St. Cloud H.; J. C. Watson, Montreal, Que., Grand Union H.; J. A. Kerr, Chicago, Ill., Brunswick H.; M. Knight, Philadelphia, Pa., Sinclair H.; A. Anderson, Boston, Mass., St. Denis H.; A. Pike, Chicago, Ill., Normandie H.; J. B. Mayo, Chicago, Ill.; C. Spandan, Pittsburgh, Pa., Imperial H.; M. Cohen, Washington, D. C., Astor H.; M. S. Liberman, Syracuse, N. Y.; Union Square H.

## Boston.

George Mace, formerly with Harrington & Freeman, will engage in business in Brookline.

The American Waltham Watch Co. have declared a semi-annual dividend of 4 per cent., payable March 15th.

George Henry, formerly with C. J. F. Sherman, of Hanover St., has started in business in Bridgewater, Mass.

Arthur Webster, son of jeweler J. E. Webster, Milford, N. H., is learning engraving under A. W. Briggs, of this city.

C. H. Daniels, Malden, Mass., has gone to Florida for the benefit of his health, and will be located till Spring in St. Augustine.

Traveling men in Boston last week included: E. W. Martin, Martin, Copeland & Co.; Eugene H. Cox, Sussfield, Lorsch & Co.; J. S. Dunham, New England Silver Co.; H. W. Dunham, Meriden Silver Plate Co.; E. C. Watson, C. W. Bullock & Co.; Mr. Franklin, E. I. Franklin & Co.

## New York Jewelers take a Lively Interest in Bowling.

The time for entries in the Jewelers Individual Bowling Championship series has been extended until Friday, March 2d, when the schedule of games will be made up. Names may be entered with the treasurer, J. F. Townley, of Ripley-Howland Mfg. Co., 17 Maiden Lane, New York. The first games will be continued each Monday night thereafter until the series is finished.

The following contestants have entered thus far: John W. Rufer, Ludwig Nissen & Co.; Harry H. Clifford, Reed & Barton; G. E. Roll, N. H. White & Co.; Harry W. Shepard, of N. M. Shepard; L. M. Sachs, of S. Lindenborn; J. F. Townley, Ripley-Howland Mfg. Co.; George H. Thompson, C. G. Alford & Co.; F. G. Thornbury, C. G. Alford & Co.; Geo. Mangold, Jr., L. Strasburger's Son & Co.; H. A. Hovet, 4 Maiden Lane; J. Parker Ford, 26 Maiden Lane; Nate Harrison, Harrison Bros.; and J. W. Woodward, Derby Silver Co.



# CLASSIFIED INDEX TO ADVERTISEMENTS.

All Advertisements are entitled to one insertion under proper heading. Extra insertions, \$6.00 per annum.  
Extra Headings, \$12.00 per annum.

Page.		Page.		Page.	
	<b>Art Pottery, Bric-a-brac, Etc.</b>		<b>Hotels.</b>		<b>Silver Plated Ware.</b>
	Ahrenfeldt, Charles & Son, 50-52-54 Murray St., N. Y. .... 38		Gibson House, Cincinnati, O. .... 21		Pairpoint Mfg. Co., New Bedford, Mass. .... 5
	Bing, Ferdinand & Co., 106 Grand St., N. Y. .. 38		<b>Jewelers' Findings.</b>		<b>Souvenir Spoons.</b>
	Borgfeldt, Geo. & Co., 18, 20 & 22 Washington Place, New York. .... 41		Lind, Thos. W., Providence, R. I. .... 27		Low, Daniel, Salem, Mass., .... 10
	Haviland & Abbot, 29 Barclay St., N. Y. .... 40		<b>Jewelry Mailing Boxes.</b>		<b>Sterling Silverware.</b>
	Healey, M. & E., Washington, D. C. .... 10		Am. Railway Supply Co., 24 Park Place, N. Y. 37		Alvin Mfg. Co., 860 Broadway, N. Y. .... 19
	Hinrichs & Co., 29 & 31 Park Place, N. Y. .... 43		<b>Jewelry, Silverware and Optical Cases.</b>		Campbell-Metcalf Silver Co., Providence, R. I. 2
	Straus, L. & Sons, 42 to 48 Warren St., N. Y. 37		Steinhaus, Theo. C., 10 Maiden Lane, N. Y. ... 4		Knowles, J. B. & S. M. Co., Silversmiths' Hall, Union Square, N. Y. .... 27
	<b>Assayers &amp; Refiners.</b>		Jackson, S. C., 180 Broadway, N. Y. .... 44		Reed & Barton, 37 Union Square, N. Y. .... 23
	Clark, J. L., Philadelphia, Pa. .... 43		<b>Jobbers, Watches, Diamonds, Etc.</b>		Shiebler, Geo. W., Co., 179 Broadway, N. Y. ... 4
	Howard, S. P., 33 Maiden Lane, N. Y. .... 44		Allen, Benj. & Co., Chicago, Ill. .... 21		Towle Mfg. Co., Newburyport, Mass. .... 43
	Schawel, J. & Co., 29 John St., N. Y. .... 44		Brethauer Watch and Jewelry Co., Chicago, Ill. 22		Wallace, R. & Sons Mfg. Co., 3 Park Place, 6
	<b>Auctioneers.</b>		Cross & Beguelin, 17 Maiden Lane, N. Y. .... 2		Whiting, F. M. & Co., North Attleboro, Mass. 37
	American Syndicate of Jewelers' Auctioneers, New York and Washington. .... 2		Freund, Max & Co., 8 Maiden Lane, N. Y. ... 11		Wood & Hughes, 10 John St., N. Y. .... 10
	Comrie, A. J., 182 Broadway, N. Y. .... 8		Myers, S. F. & Co., 48 Maiden Lane, N. Y. .... 44		<b>Show Cases.</b>
	Prince, J., 137 Broadway, N. Y. .... 19		Oppenheimer Bros. & Veith, 35 Maiden Lane, N. Y. .... 27		Smith, B. & W. B., 220 W. 29th St., N. Y. .... 44
	Scott, De B. O., 20 Murray St., N. Y. .... 5		<b>Leather and Silver Goods.</b>		<b>Spectacle and Eyeglass Cases.</b>
	<b>Badges, Medals, Etc.</b>		Deitsch Bros., 7 E. 17th St., N. Y. .... 2		Birmingham, Wm. & Co., 728 Arch St., Phila. 4
	Irons & Russell, Providence, R. I. .... 42		<b>Musical Boxes.</b>		White, W. B. & Son, Boston, Mass. .... 4
	Stochlechter, G. A., Reading, Pa. .... 43		Jacot & Son, 298 Broadway, N. Y. .... 2		<b>Stem Winding Attachments.</b>
	Stockwell, E. R., 19 John St. N. Y. .... 43		<b>Optical Goods.</b>		Abbott, Henry, 2 Maiden Lane, N. Y. .... 28
	Willson, Chas. G., Reading Pa. .... 37		Berger, Albert & Co., 47 Maiden Lane, N. Y. .. 33		<b>Tortoise Shell Goods.</b>
	<b>Clocks, French, English and American.</b>		Geneva Optical Co., Chicago, Ill. .... 24		Potter, W. K., Providence, R. I. .... 5
	Jacques, Chas., Clock Co., 22 Cortlandt St., N. Y. .... 44		Kirstein's, H. E., Sons Co., Rochester, N. Y. ... 43		<b>Tool Manufacturers and Dealers.</b>
	<b>Chamois Skins.</b>		Queen & Co., Philadelphia, Pa. .... 4		American Watch Tool Co., Waltham, Mass. .. 8
	Taylor, Geo. C., 26 Cortlandt St., New York. 10		Spencer Optical Mfg. Co., 15 Maiden Lane, N. Y. 19		Bullock, O. W. & Co., Springfield, Mass. .... 4
	<b>Diamond &amp; Precious Stone Importers.</b>		The Nous Verrons Co., Boston, Mass. .... 37		Gesswein, F. W., 39 John St., N. Y. .... 38
	Disselkoben, John N., 19 E. 16th St., N. Y. 29		<b>Optical Schools.</b>		Hardinge Bros., Chicago, Ill. .... 22
	Eichenberg, Julius, Providence, R. I. .... 28		The Chicago Ophthalmic College, Chicago, Ill. 23		Logan, A. J., Waltham, Mass. .... 5
	Falkenau, Oppenheimer & Co., 40 Maiden Lane, N. Y. .... 44		<b>Office Building.</b>		Moseley & Co., Elgin, Ill. .... 21
	Hedges, Wm. S. & Co., 170 Broadway, N. Y. ... 28		Cruikshank, E. A. & Co., 176 Broadway, N. Y. 8		Oliver, W. W., Buffalo, N. Y. .... 24
	Kipling, R. A., Hays Bldg., N. Y. .... 28		Diamond Exchange Building, 14 Maiden Lane. 7		<b>Trunks and Traveling Bags.</b>
	Randel, Baremore & Billings, 29 Maiden Lane		<b>Paper Boxes.</b>		Crouch & Fitzgerald, 161 Broadway, N. Y. .... 28
	Smith, Alfred H. & Co., 182 Broadway, N. Y. ... 28		Warner Bros., Bridgeport, Conn. .... 3		<b>Watch Manufacturers.</b>
	Tannenbaum, L., & Co., cor. Maiden Lane and Nassau St., N. Y. .... 15		<b>Paneled Metal.</b>		Charmilles Watch. .... 11
	<b>Engraving Machines.</b>		Northrop & Co., Pittsburgh, Pa. .... 37		<b>Watch Case Manufacturers.</b>
	Francis, A. E., Cleveland, Ohio .... 43		<b>Pens, Pencil Cases, Etc.</b>		Roy Watch Case Co., 21 Maiden Lane, N. Y. .... 26, 28, 30
	<b>Fine Stationery.</b>		The Boston Pen Co., Boston, Mass. .... 4		The Planchamp & Becker Co., Chicago, Ill. ... 24
	Parsons & Greene Co., 18 Murray St., N. Y. ... 5		<b>Patents.</b>		Wadsworth Watch Case Co., Newport, Ky. .... 25
	<b>Gold and Silver Plating Works.</b>		Belt, C. T., Washington, D. C. .... 44		<b>Watch Dials.</b>
	Bolstad Mfg. & Plating Co., Chicago, Ill. .... 24		<b>Platinum Importers.</b>		O'Hara Waltham Dial Co., Waltham, Mass. 28
	Brunor, Emil, 93, 95, 97, William St., N. Y. ... 35		Schawel, J. & Co., 29 John St., N. Y. .... 44		<b>Watchman's C ocks.</b>
	<b>Gold Jewelry.</b>		<b>Ring Makers.</b>		Hausburg, O. E., 41 Maiden Lane, N. Y. .... 33
	Carter, Sloan & Co., 15 Maiden Lane, N. Y. ... 29		Bryant, M. B. & Co., 10 Maiden Lane, N. Y. ... 44		<b>Watch Importers.</b>
	Johnson, R. M., 67 Washington St., Chicago, Ill. 22		Bowden, J. B. & Co., 192 Broadway, N. Y. ... 7		Hyde's, J. E., Sons, 22 Maiden Lane, N. Y. ... 43
	Krementsz & Co., 182 Broadway, N. Y. .... 2		Hildreth Mfg. Co., 53 Maiden Lane, N. Y. .... 8		Mathey Bros., Mathez & Co., 21 & 23 Maiden Lane, N. Y. .... 8
	Pfeil, Chas. H., Chicago, Ill. .... 24		<b>Rubber Stamps and Type.</b>		<b>Watch Keys.</b>
	Smith, Wm., & Co., 5-7 Maiden Lane, N. Y. ... 44		Dietz, Wm. H., Chicago, Ill. .... 23		Clark, A. N., Plainville, Conn. .... 2
	Street, Geo. O. & Sons, 15 John St., N. Y. .... 33		<b>Sample Trunks.</b>		<b>Watch Repairers.</b>
	Unger Bros., 192 Broadway, N. Y. .... 12		Crouch & Fitzgerald, 161 Broadway, N. Y. .... 28		Muller, Hugo, Chicago, Ill. .... 24
	Webster, G. A., Chicago, Ill. .... 19		<b>Silver Mounted Ebony Goods.</b>		
	<b>Gold and Rolled Plate Jewelry.</b>		Deitsch Bros., 7 E. 17th St., N. Y. .... 2		
	Foster & Bailey, Providence, R. I. .... 3				
	Read, M. L. & Co., Providence, R. I. .... 9				
	<b>Horological Schools.</b>				
	American Horological Institute, Lancaster, Pa. 24				
	Chicago Watchmakers' Institute, Chicago, Ill. 22				
	Elgin Horological School, Elgin, Ill. .... 24				
	Parson's School for Watchmakers, Peoria, Ill. 24				



## Special Notices.

Rates 75c. per insertion for notices not exceeding 5 lines (25 words), additional words 2 cents each. If answers are to be forwarded, postage stamps must be enclosed. Two insertions, 15 per cent. off; three insertions, 20 per cent. off; four insertions or more, 25 per cent. off. Payable strictly in advance. Display cards on this page will be charged at \$2.00 per inch for first insertion, subject to same discount as above for subsequent insertions.

Under the heading of **Situations Wanted** on this page advertisements will be inserted for **One Cent a Word**. This offer refers to **Situations Wanted only**. Payable strictly in advance. If answers are to be forwarded, postage must be enclosed.

## Situations Wanted.

Notices under this heading **ONLY** are charged at one cent a word, payable strictly in advance. If answer are to be forwarded, postage must be enclosed.

A JEWELER wants position with a wholesale or retail store, to take charge of shop, making and repairing. Address Metallurgist, care JEWELERS' CIRCULAR.

WANTED, a position in factory or as traveling salesman by a gentleman of 25 years' experience in the plain gold ring business. Address "H," care of JEWELERS' CIRCULAR.

SITUATION WANTED by watchmaker and jeweler; young man; three years' experience; best of references. Address W. A. Babcock, Walnut, Ill.

WANTED, SITUATION—Manager of a business for two years past. Do all branches of work—watchmaking, engraving, seal making, jobbing, selling, buying. Box 695, What Cheer, Ia.

SITUATION WANTED by watchmaker who thoroughly understands his business. Competent on chronographs and French clocks. Does all kinds of jewelry repairing. Good salesman. Address "Energetic," care JEWELERS' CIRCULAR.

SALESMAN.—Young man 23 years, wants position; acquainted with wholesale and retail jewelry trade; salary moderate. A. L. H., care JEWELERS' CIRCULAR.

SITUATION wanted by first-class watchmaker, jewelry repairer, clerk and do common engraving; young man and married; have bench and tools. Address 315 Day St., Decorah, Iowa.

WANTED Position as salesman or jeweler and watchmaker; 15 years' experience; can furnish the best of references. Address V., JEWELERS' CIRCULAR.

WANTED—Position by first-class watchmaker; had 20 years' experience on all kinds of watches, clocks, chronographs and chronometers; speaks French and a little English. Address S. Joseph, 17 Rector St., New York City.

A FIRST-CLASS watchmaker seeks position as foreman, manager or otherwise, in a good house, town or country. Competent in all complicated and plain watch work. At New York references. English; speaks and writes French. Address Pivot, 361 Cumberland St., Brooklyn, N. Y.

WATCHMAKER, 10 years' experience in largest cities in the United States, wants place at once. Can do all kinds of work—jobbing, fine engraving and fine watch repairs on complicated work, striking watches, etc. Will go on percentage in a small town if the place is lively. Best references, or bonds if desired. Address Box 348, Madison, Minn.

SITUATION WANTED by first-class watchmaker and optician. Experienced. Position permanent. Salary, \$20.00 per week. Married. Address G. B., 95 Brenton St., Cleveland, Ohio.

YOUNG MAN wants position where he can learn the jewelers' trade. Good engraver; have samples. Good references and industrious. Address Engraver, care of THE JEWELERS' CIRCULAR.

SITUATION WANTED as watch and clock maker; also jewelry repairer; age 21; speaks English and German; good references. Address A. Guenther, 875 Sixth Ave., New York.

TRAVELING SALESMAN with established trade wants two manufacturers' lines on commission to sell retail trade. Address "E," care THE JEWELERS' CIRCULAR.

## Help Wanted.

WANTED—A first class workman who can make and repair fine jewelry and who thoroughly understands electro-coloring. Address Bell Bros Co., O densburg, N. Y.

WANTED—Manufacturing jeweler and engraver; one who is competent and understands all branches of the business; permanent situation; state age and salary wanted. Address Birely & Son, Oshkosh, Wis.

TRAVELING SALESMAN wanted, visiting the retail jewelry trade to carry side line on commission; samples small, attractive and great sellers. Address "Syntax," JEWELERS' CIRCULAR.

## To Let.

TO LET.—A large office, 20 x 40, first floor, No. 11 Maiden Lane. \$90 a month.

TO LET AT LOW RENT—Two very desirable offices, one and two flights up, in building, No. 12 Maiden Lane. For particulars apply to Lissauer & Co., 12 Maiden Lane, N. Y.

FOR RENT in Corbin building, 11 John St., sixth floor, half of an office with or without large safe convenient for jeweler. For further particulars, address the janitor of the building.

TO LET FOR BUSINESS PURPOSES.—Broadway store near the Post Office; desirable location; moderate rent; lease. Apply on premises, 2 Astor House.

TO LET—Store at 264 1/2 Bowery, which has been occupied as a jewelry store since 1870. It is in a good locality. Will be rented to a responsible party at a low figure. Apply to Jacob Friedlander, 65-67 Nassau St., New York.

## Miscellaneous.

I BUY JEWELRY STOCKS—Manufacturers, jobbers and retailers desiring to dispose of surplus or entire stocks of diamonds, watches and jewelry can find quick cash buyer by addressing Stephen S. Harmon, 134 East 96th St., New York City.

## DEMAGNETIZING.

PERFECT WORK—Watch repairing in all its branches; all work warranted. Winslow & Penney, 608 Masonic Temple, Chicago.

FOURTEEN karat gold solder that will flow on eight karat work; makes a hard solder job a pleasure. With this solder there is no danger of melting low karat specs. No white joints on rings. It is just what you want. Sample by mail 25 cents. F. W. Hall, Sterling Silver Novelties, Columbus Memorial Building, Chicago, Ill.

SEND for new 1894 prospectus of Trowbridge's Engraving School. Lowest terms of any school. Board \$12 to \$15 per month. Winona, Minn.

ENGRAVING MACHINE, also optometer for watches, or anything I can use. Address W. A. Sherwood, care JEWELERS' CIRCULAR.

WANTED—A partner having \$4,000 or \$5,000 to buy a half interest in a good paying jewelry business in New York State. Practical man preferred. Address Brown, care JEWELERS' CIRCULAR.

WANTED PARTNER—A practical jeweler, who has \$2,000 in cash, can buy a half interest in a well established and good paying business, in one of the brightest manufacturing cities in the United States. Address "Partner," care CIRCULAR.

MANUFACTURERS selling the jobbing trade can make very advantageous arrangements with experienced salesmen to represent their goods in New York City and cover jobbing trade throughout the United States. Address "Copious," JEWELERS' CIRCULAR.

\$300 WILL BUY watch, clock and jewelry repairing business, with safe, engraving machine, lathe and small tools and material, also work on hand; town of 3,500 inhabitants; no opposition. Address T. Courtney, Westport, Conn.

## For Sale.

FOR SALE.—A first class polishing lathe; all in good repair, at a low price for cash. Address G. W. Brown, 113 Point St., Providence, R. I.

FOR SALE.—Whitcomb 1 1/2 lathe, hand, with attachments. In perfect condition. Sold for want of use. Cash, at half price. For list of tools and particulars, address Wm. Gibbs, Helena, Mont.

FOR SALE—Jewelry store in New York City; must sell on account of other business at once. \$3,500. For particulars address "Beyer," care JEWELERS' CIRCULAR.

## FOR SALE

IN

## CHICAGO.

An old established Retail Jewelry Business, on a very prominent corner in the business portion of the city. Fine Fixtures and a Clean Stock. A big bargain may be obtained, as owner wishes to retire.

Address C. B. S., care JEWELERS' CIRCULAR.

## FACTORY AND OFFICE TO RENT FROM MAY 1ST.

Desirable office on first floor with factory on fourth floor. John St., between Broadway and Nassau St. Office, 25x40; factory 25x75. Both connected by elevator and speaking tube. Factory well lighted and ventilated by four high sky-lights. Steam power according to wants. Rent \$2,000, or factory alone \$1,000. Address A. B. care JEWELERS' CIRCULAR.

## TO LET.

One of the most desirable Offices

— IN THE —

## HAYS BUILDING,

### 21 and 23 MAIDEN LANE.

APPLY AT OFFICE OF THE BUILDING.

ALBERT BERGER & CO  
47 MAIDEN LANE, N. Y.  
Spectacles & Optical Goods,  
GROUND LENSES A SPECIALTY.

ESTABLISHED 1837.

## GEO. O. STREET & SONS,

MAKERS OF

### Fine Rings, Lockets, Seals, Sleeve Buttons and Links

15 John Street, NEW YORK.

Headquarters  
FOR  
ELECTRIC & PORTABLE  
Watchman's Clocks  
Lowest Prices.  
Latest Improvements,  
Patents 1888-1893.  
Send for Circular.  
E. O. HAUSBURG,  
41 Maiden Lane, New York. THE "ALERT."

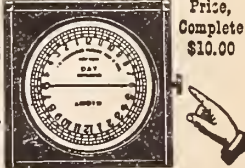



**The Latest Patents.**

ISSUE OF FEBRUARY 13, 1894.

**511,170. MUSIC-BOX ATTACHMENT FOR CLOCKS.** CHARLES H. JACOT, Stapleton, assignor to Jacot & Son, New York, N. Y.—Filed Apr. 19, 1893. Serial No. 470,939. (No model.)

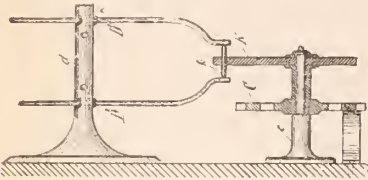

The combination with a music cylinder and its escapement of a lever D having an arm 3, locking lever d adapted to lock lever D weighted lever E connected with said lever D, and means substantially as described for operating it at predetermined intervals.

**511,565. COMBINED UMBRELLA TIE AND NAME PLATE.** WILLIAM E. MURBARGER, Indianapolis, Ind.—Filed Jan. 13, 1893. Serial No. 458,280. (No model.)



A device for holding umbrellas closed comprising an elastic metal plate having at one end a tubular socket, a spiral spring secured at one end in said socket and provided at its other end with an enlarged head, said plate being provided at its other end with a pair of in-turned lips adapted to receive and hold the enlarged head of the spring.

**511,611. ELECTRIC PENDULUM CLOCK.** HENRI CAMPICHE, Geneva, Switzerland.—Filed July 28, 1893. Serial No. 481,682. (No model.)

The combination of a pendulum B and an electric circuit connecting an electric source G with an electric clock, with an electro-magnet E, and a device for interrupting the circuit, consisting of the contact fork D<sup>1</sup>, D<sup>2</sup>, and a device which acts temporarily upon the said interrupter of the circuit so as to close the circuit after

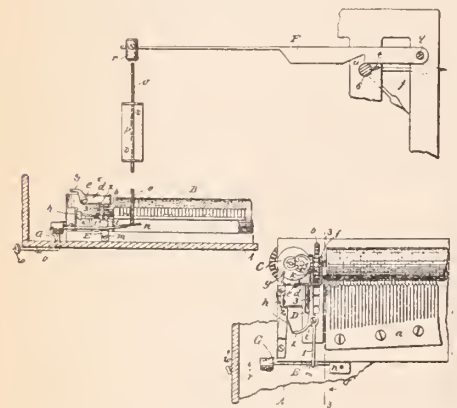

a certain number of vibrations of the pendulum, the armature of the electro-magnet E being arranged so as to give a mechanical impulse to the pendulum each time the electric circuit is closed and the jump of the hands of the clocks F produced.

**511,618. METHOD OF MAKING DIES FOR WATCHCASE-CENTERS.** FREDERIC ECAUBERT, Brooklyn, N. Y.—Filed May 8, 1893. Serial No. 473,388. (No specimens)

The method herein specified of making the ring die for scalloped watch case centres or similar articles consisting in recessing the inner surface of the ring die at the proper places and while the steel is in a soft con-

dition, pressing into the interior surface of such ring an ornamenting roller having a scalloped edge with the surfaces of the scallops ornamented with the desired ornamental or engraved lines, rotating the respective parts and applying the proper pressure until the scallops of the knurling roll are embedded into the in-

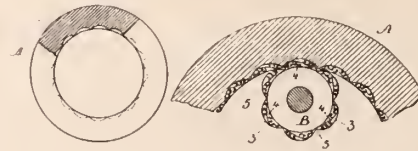

terior of the soft metal ring turning off and finishing the exterior surfaces of such ring and hardening the same.

**511,799. WATCH-BOW PLIERS.** HENRY W. WILDT, Alexandria, Va.—Filed July 19, 1893. Serial No. 480,942. (No model.)

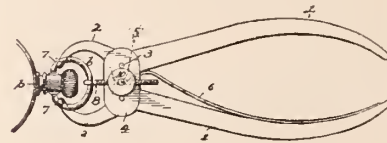

The watch-bow pliers constructed substantially as herein described with hooked jaws adapted to engage with the watch-bow for springing the same open.

**DESIGN 23,057. HANDLE FOR SPOONS, ETC.** JOHN W. MAILLOI, North Attleboro, Mass.,

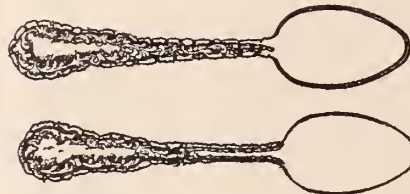

assignor to F. M. Whiting & Co., same place.—Filed Jan. 15, 1894. Serial No. 496,987. Term of patent 3½ years.

**DESIGN 23,058. BADGE HEADING.** EDWARD L. TORSCH and JAMES R. LEE, Baltimore, Md.—

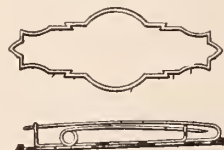

Filed Jan 12, 1894. Serial No. 496,682. Term of patent 7 years.

**DESIGN 23,060. BOOK-MARK.** LOUISE J. HUESTIS, New York, N. Y., assignor to the



Corporation of J. H. Johnston & Co., same place.—Filed Nov. 6, 1893. Serial No. 490,163. Term of patent 3½ years.

**Expired Patents.**

EXPIRED FEB. 13, 1894; GRANTED FEB. 13, 1877.

**187,238. PEN HOLDERS.** D. M. SOMERS, New York, N. Y.—Filed July 12, 1876.

A pen holder tip consisting of a tube having one end bent inwardly to form double walls, which provide a pen recess between them, one of which walls is solid while the other is split longitudinally to form spring nibs.

**187,305. REPEATING WATCHES.** AMI L. JUNOD-PATTUS, Sainte Croix, Switzerland.—Filed Aug. 15, 1876.



The combination of the push piece 3 with the rack 9 and hammer 12, and with the pinion 2, all arranged so that by one motion of the push piece 3 the rack will be thrown into gear with the pinion and the hammer set.

**187,362. TABLE FORKS FOR GREEN CORN,** &c. F. M. DIXON, Philadelphia, Pa.—Filed Aug. 28, 1876.

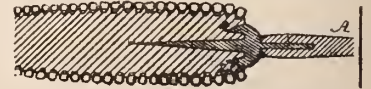

The fork herein described, the same consisting of the longer tine 1, projecting taperingly to a sharp point in alignment with the straight handle A, and of the two shorter tines 2 2, each tapered to a sharp point in the same direction as that of the longer tine 1.

ISSUE OF FEBRUARY 20, 1894.

**511,958. COMPOSITION FOR SILVER PLATING.** GEORGE W. ODELL, Butte, Mont.—Filed June 19, 1893. Serial No. 478,059. (Specimens.)

A silver plating alloy or composition, composed mainly of quicksilver and paraffine, and of relatively small quantities of sodium, lead and zinc or tin.

**511,971. WATCHMAKERS' BENCH-TOOL.** CHARLES A. STEBBINS, Lawrence, Mich.—Filed April 17, 1893. Serial No. 470,707. (No model.)



A tool comprising a suitable stock having a table-like top, a hole or socket in said top, an open mortise leading laterally from said hole, said open mortise being of a depth corresponding to the proper height of the roller jewel of a watch and adjustable clamping jaws attached to the top of the stock as set forth.

**515,146. CONNECTING SPRING FOR EYE-GLASS FRAMES.** HENRY H. HEMPLER,



Washington, D. C.—Filed April 4, 1892. Serial No. 427,766. (No model.)



A connecting spring for eyeglass frames composed of a flat piece of spring material formed into an inwardly extending spiral at each side of its center and its ends extended downward and connected with the inner sides of the frames.

**515,166. BAG OR PURSE FRAME.** LOUIS B. PRAHAR, Brooklyn, N. Y.—Filed Nov 7, 1893. Serial No. 490,238. (No model.)

**515,189. ELECTRIC TIME-ALARM.** JOHN C. BETTS, Philadelphia, Pa.—Filed August 8, 1893. Serial No. 482,642. (No model.)

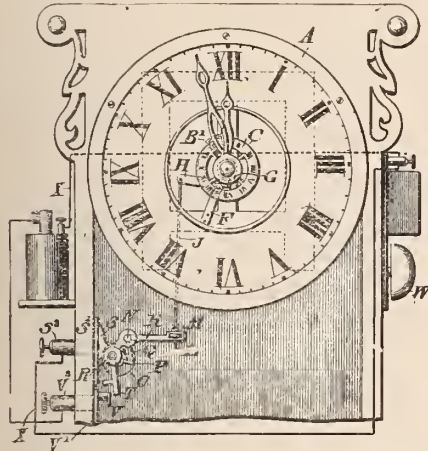

In an alarm attachment to a clock, a setting dial having a split sleeve provided with a shoulder and secured thereto, a collar on said sleeve bearing against said shoulder, an arm secured to said collar, and a cam on said dial.

**515,231. MICROMETER-GAGE.** JOSEPH P. LAVIGNE, New Haven, Conn. Filed Jan. 7, 1893. Serial No. 457,666. (No model.)

**515,235. MICROMETER-GAGE.** JOSEPH P. LAVIGNE, New Haven, Conn. Filed Jan. 7, 1893. Serial No. 457,608. (No model.)

**515,236. MICROMETER SURFACE-GAGE.** JOSEPH P. LAVIGNE, New Haven, Conn. Filed Feb. 20, 1893. Serial No. 463,038. (No model.)

**515,257. CYCLOMETER.** IRVING SHELDON, Danbury, Conn. Filed Au 7, 31. 1893. Serial No. 484,452. (No model.)

**DESIGN 23,076. BOOK-MARKER.** BENJAMIN



S. SAMUELS, New York, N. Y. Filed Jan. 9, 1894.

Serial No. 496,323. Term of patent 3½ years.

**TRADEMARK 24,243. WATCH-MOVEMENTS.** JOHN J. MCGRANE, New York, N. Y. Filed Jan. 11, 1894.

## PRESIDENT.

*Essential feature.*—The word "PRESIDENT." Used since April 1, 1893.

### Expired Patents.

EXPIRED FEB. 20, 1894; GRANTED FEB. 20, 1877.

**187,649. NAPKIN HOLDERS.** W. F. LEWIS and R. T. LATTIN, Waterbury, Conn. Filed Oct. 30, 1876.



The napkin-holder consisting of the base *f*, the hook *g*, and the spring clamping device *i h c k*, on the inner side of the base, the whole being arranged for operation together.

**RE-ISSUE 7,514. REGULATING WATCHES.** C. FASOLDT, Albany, N. Y. Patent No. 42,175, dated April 5, 1864. Filed Nov. 22, 1875.

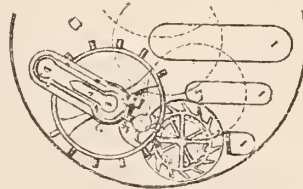

In combination with the time-regulating mechanism of a watch, the regulating screw *F*.

### H. H. Pratt Succumbs to Poor Business.

FREMONT, Neb., Feb. 24.—H. H. Pratt, who has been in the jewelry business here longer than any other firm, has succumbed to the pressure of hard times, and his stock is now in the hands of creditors. His troubles culminated last week in his giving chattel mortgages on his stock covering \$3,105 due to creditors, as follows:

Farmers & Merchants' National bank.	.....\$400 00
Commercial National bank	..... 560 70
C. F. Dodge	..... 591 93
Grant Strack	..... 360 00
Meriden Britannia Co	..... 194 18

George F. Wolz	..... 100 00
Pairpoint Mfg Co	..... 261 70
Gorham Mfg. Co.	..... 165 00
M. A. Mead & Co.	..... 434 88
C. F. Happel & Co.	..... 36 70

The stock is withdrawn from sale and will be invoiced and appraised and sold to pay the claims. The total liabilities are about \$5,200 and the stock is valued at about \$7,500, although it is doubtful if more than enough can be realized at forced sale to pay the liabilities. Mr. Pratt has been in the jewelry business in Fremont for seventeen years and has always paid strict attention to business.

### A Firm of Jewelers Charged with Arson.

SAN ANTONIO, Tex., Feb. 21.—Abe Samuels and C. Jordt, of the firm of Samuels & Jordt, jewelers and pawnbrokers, were today indicted by the Grand Jury, charged with arson. The store of this firm was badly damaged by fire on Dec. 17, and it is alleged that Samuels and Jordt were the incendiaries. They were released on bond.

## Paper Boxes

At Prices Which Defy  
Competition.

PLAIN AND FANCY JEWELRY  
AND SILVERWARE BOXES  
OUR SPECIALTY.

Our large dealings in Satins, Silks and Sateens in the Corset Business, together with special machinery, enable us to do the **BEST OF WORK AT LOW PRICES.** Quotations promptly furnished upon receipt of sample.

Address

**Warner Bros.,**

Bridgeport, Conn.

Box Department.



## A NEW BOOK.

# The :: Practical :: Electroplater.

By MARTIN BRUNOR.

Over 200 receipts for electroplating, oxidizing, coloring, electrotyping, removing the green, etc.

Recommended by competent platers and manufacturers.

Handsomely bound in half morocco. Price, \$10.00. Sold by subscription only. No Agents.

FOR SALE BY **EMILE BRUNOR, 93, 95, 97 William St., New York.**

Can be seen at the Jewelers' Circular office, 189 Broadway, N. Y.



## Watch With New Style of Winding.

THE very small, high watches, inserted in glass balls, umbrella and cane handles, etc., especially on the Continent, are generally wound in such a manner that either the glass bezel or a specially milled bezel on the middle part of the casing is turned either to the right or the left; the hands are set by turning the same bezel the contrary way, while at the same time pressing in a button at the side of the case. THE CIRCULAR presumes that not everyone of its readers is acquainted with the winding and setting mechanism used for the purpose, and therefore

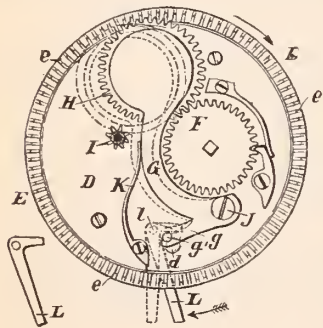

FIG. 1.

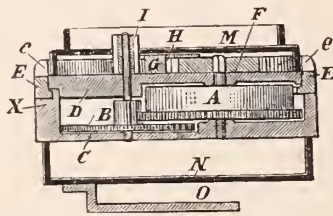

FIG. 2.

it translates the description of the latest device, for which a Swiss patent was granted to L. J. Richard, of Geneva, Switzerland.

Fig. 1 represents the plan of such a winding mechanism on an enlarged scale; Fig. 2, a side view of the whole movement with cross section of plates. Both illustrations show beside the frame of the movement only the barrel, center wheel and the winding wheel.

The barrel A, and center wheel B, Fig. 2, lie between the two main plates C and D, furnished with suitable recesses. The plates lock one into the other in the manner shown at X—that is, the upper plate D projects a little over the narrow rim of the deeply turned-out bottom plate C. By this is formed between the rims of these two plates a circular groove, in which the inner rim of the large annular winding wheel E is placed. This wheel, similar to the barrel wheel of the well-known small musical boxes, is fur-

nished with teeth, *ee*, Figs. 1 and 2, standing vertical to the plane of the wheel; these teeth project with their full length beyond the surface of the plate D.

Upon the plate D, Fig. 1, lies upon the square of the barrel arbor, the winding and ratchet wheel F, also the pivoted detent G which revolves around the shoulder screw J, and the transposition wheel H, between the detent G and the plate D, which on the one hand stands in constant depthing with the teeth *ee* of the large winding wheel, while on the other hand it can at desire be brought into or taken out of depthing with the barrel ratchet F or the pinion I. This pinion I is located upon the center staff, and stands in direct connection with the motion work of the watch. The pivoted detent G, Fig. 1, is furnished with a short arm *g* in which is a pin *g*<sup>1</sup>, which protrudes through a hole *d* in the plate D, and beyond it is seized by the cross arm of the setting bar L. This bar revolves around the point *l*.

Ordinarily, the setting bar L occupies the position shown by dotted lines in Fig. 1, and the detent G is by the spring K held in such a position that the transposition wheel H stands in depthing with the ratchet wheel F. When, now, the large winding wheel E is turned to the right in the direction of the arrow, the watch is wound, while by turning to the left the wheel E, the teeth of the wheel snap out of the barrel ratchet F, and the spring K then acts as maintaining-power spring.

To set the hands, the setting bar L is pushed in the direction of the arrow, so that it assumes the dotted line shown in Fig. 1, and retains it in this position, while at the same time the milled bezel on the large winding wheel E (omitted in the illustration) is turned to the left. The detent G is thereby displaced by its pin *g*<sup>1</sup> in the dotted position, whereby the wheel H is taken out of depthing with the wheel teeth F, and placed in depthing with the pinion I, Figs. 1 and 2.

The remaining part of the movement frame can be seen in Fig. 2. It consists of the two auxiliary plates M and N, as well as the balance potence O. In the center of the plate M is the cannon pinion, by which the minute wheel stands in connection with the pinion I; the plate M also carries the dial. Between the plates C and N are the two small wheels of the running work (third and fourth wheels), as well as the escape wheel. The movement is in this manner made to comply with its special purpose; although it is very high, yet it may be made very small, without the necessity of making the several parts so small as is customary with ordinary watches of the same size.

## Workshop Notes.

**Timing.**—It is the usual practice among adjusters in timing to position with a balance with quarter screws, to test the watch in the position known as "stem up," and if in that position the watch is found to gain, the side of the balance which is down when the balance is in a state of rest, is rendered a trifle lighter by turning the quarter screw which is on that side of the balance; in other words, making the lowest side of the balance lighter. This rule, however, holds good only if the balance has one full turn or less, if the balance makes more than a full revolution, the reverse is the result from making the lower side of the balance the lightest. Now comes a difficulty, which occurs in going-barrel watches as they always have a large arc of vibration when first wound than when nearly run down; consequently it will be understood that a man who carries his watch during the daytime in a vertical position, and lays it down nights, will find his watch to vary.

**Pallet Lockings.**—In respect to the pallet lockings, the equality of sharpness of draft inward is readily judged to be about equal by trial. Some persons try them by placing the guard pin against the round edge of the roller and gently putting the peg on the escape wheel. But the equality of the draught inward does not quite prove their equal resistance to the reciprocated force of the balance, nor does the writer know of any way to prove when they are so strictly, but he will make some remarks about them. It is to be observed that the two lockings are at unequal distances from the center of the pallet, and also that with deeper depths the wheel drops further under the inside locking, so that in unlocking the wheel has to be moved further back to get the locking out from under the tooth; still, as the radius to the inside locking is the shortest, therefore the long arm of the lever bears a greater ratio to that shortest pallet radius, and although the inside locking of itself may be a trifle the hardest, yet it may not subtract any more velocity from the balance in unlocking than the outside one; and, indeed, if the inside locking of itself was as easy to unlock as that of the outside, we should then be certain that the resistance to the force of the balance would be unequal, as the two radii of the lockings were unequal. Unequal radii must have unequal resisting lockings to subtract equal portions of velocity from the same reciprocated force of the balance.

F. A. Kruger, a jeweler of Somerville, Mass., while returning to his home recently, found a satchel containing \$2,850 in greenbacks in a car on the Fitchburg railroad. He learned that the money belonged to a wealthy business man of Belmont, and he at once returned to him his property without receiving a word of thanks and only one dollar for his honesty.

This is to certify that the undersigned have formed a limited partnership, pursuant to the provisions of the Revised Statute of the State of New York. That the name or firm under which said partnership is to be conducted is F. S. Maynard & Son. That the general nature of the business intended to be transacted is importing and dealing in foreign and domestic fruits and produce; that the names of the general and special partners interested therein are as follows: Edwin C. Maynard, who resides at Jersey City, N. J., is the general partner, and Isabel Maynard, who resides in the City of Brooklyn, State of New York, is the special partner. That the said Isabel Maynard has contributed the sum of \$5,000 as capital to the common stock and that said co-partnership is to commence on the first day of May, 1893, and is to terminate on the first day of May, 1898. Dated this first day of May, 1893.

E. C. MAYNARD, General partner.

ISABEL MAYNARD, Special partner.

City and county of New York, ss.  
On this first day of November, 1893, before me personally appeared Edwin C. Maynard and Isabel Maynard, to me known and known to me to be the individuals described in and who executed the foregoing instrument and they severally acknowledged to me that they executed the same.  
LEONARD S. WHEELER,  
Notary Public, N. Y. County.





# L. STRAUS & SONS,



IMPORTERS AND MANUFACTURERS,

China, Pottery and Glassware, 42, 44, 46 & 48 Warren St. and 116 Chambers St., N. Y.  
PARIS, CARLSBAD, RUDOLSTADT, LIMOGES, STEINSCHONAU.

## THE WARREN EYE PROTECTOR.

(Patented Jan. 12, 1892, Feb. 21, 1893.)

SAVES THE EYES FROM **Dust, Wind, or Glaring Light.**

FOLDS, IN A COMPACT CASE, IS

**COMFORTABLE, DURABLE, WATER AND DUST PROOF.**

Its large field does not obstruct the sight. No brittle substance to endanger face under sudden blows. Oculists and Physicians recommend it.

Travelers, Cyclists, Railroadmen, Horsemen, Motormen, Quarrymen,  
PRONOUNCE IT INDISPENSABLE FOR MAN OR WOMAN.

ASK YOUR DEALER FOR IT,

Colors, Clear, Smoke, Blue or Green. Black frames, 50c. Silver, 75c. Sent by mail on receipt of price. Manufactured solely by

**The Nours Verrons Company.** P. O. Box 3273,  
BOSTON, MASS.

### Enterprising Jewelers Catch On!



OBVERSE



REVERSE



BACK

**Jewish Shekel, Masonic Mark or Pocket Piece.**  
THE LATEST AND BEST SELLING NOVELTY.

The mark is struck in coin silver; by using either the obverse or reverse of the coin, the back being the same in either case, and permitting of the purchaser's name, blue lodge, chapter and individual mark, with date of same being engraved thereon, as shown in cut above.

Price, without engraving, ONE DOLLAR, Engraved Mark, Dates, etc., 75c. EXTRA.

Liberal Discount to the Trade.

**CHAS. G. WILLSON, MANUFACTURING JEWELER, READING PA.**

### PATENT paneled METAL **CEILING** Stamped Raised Panels. ARTISTIC AND PERMANENT.

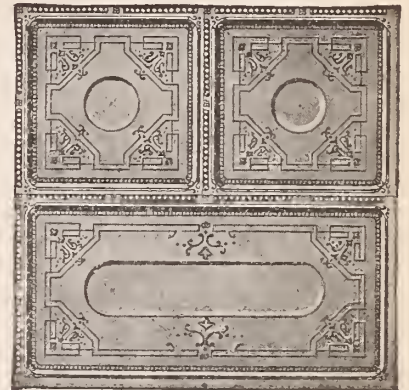

Easily applied in new buildings, and over old broken plaster or wood Ceilings. If interested in building or repairing, send stamp for Illustrated Catalogue, and state if **CHURCH, HALL, STORE, OFFICE,** or **SCHOOL** Ceiling is wanted. Address

**A. NORTHROP & CO., Pittsburg, Pa.**



**AMERICAN RAILWAY SUPPLY CO.**  
24 Park Place, NEW YORK.

## DAMASCUS

Made in a full line. The Best Pattern of the Season. Ready this Season. A general line of **Hollow Ware.** New Ideas Constantly.



DAMASCUS TEA.



**F. M. WHITING & CO.,**  
Manufacturers of **STERLING SILVERWARE,** Novelties in Silver Jewelry.

NORTH ATTLEBORO, MASS.



# FERDINAND BING & Co.,

106 GRAND ST., N. Y.

—NEW DESIGNS IN—

China Clocks and Gilt Bronze Sets, Fine Painted Dresden Goods in  
Vases, Cups and Saucers, and Plates; Cararra Marble Statuary,  
French Cabinets and other Fancy Furniture.

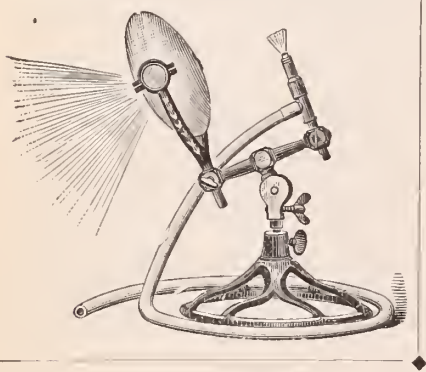

## F. W. GESSWEIN,

39 JOHN STREET,

NEW YORK.

### ENGRAVERS' REFLECTORS

FOR OIL OR GAS, SINGLE OR DOUBLE.

The Glass Reflecting Globe magnifies and concentrates the light, and can be adjusted to cast it on any desired point.

... Circulars and Price Lists on Application ...

OUR IMPORT LINES OF

# China, Glass AND Bric-a-Brac

..... ARE COMPLETE .....

WE CALL PARTICULAR ATTENTION TO THE FOLLOWING SPECIALTIES:

LIMOGES CHINA AND SAXONIA WARE, ROYAL DRESDEN CHINA,  
SEVRES PORCELAIN, PARIS NOVELTIES, VIENNA CROWN  
WARE, ROYAL BONN & DELFT FAIENCE,  
AUSTRIAN GILT GLASS.

## CHARLES AHRENFELDT & SON,

50, 52 & 54 Murray Street, New York.





## Henry Cros' Works in Plastic Glass.

THE sculptor Henry Cros, besides being a prominent artist, is an *esprit chercheur*. He is always endeavoring to find new processes which might enable him to give novel appearances to works of art which do not admit, as a rule, of a great variety. He began with producing original statuettes in colored terra cotta, among which are a bust of *Gitana*, now on view at the Sèvres Museum, as well as some potteries *grand feu*, some tinted marble works and polychrome wax figurines. Then he endeavored to evolve a process to produce plastic glass, which could be handled like clay. He had read in Pliny that the ancients obtained wonderful effects with glass; that they could knead it like clay, and that a defectuous glass vessel could be bent into shape in the same way as if it had been in metal. Besides, he noticed at the Louvre two antique medallions in a vitreous substance, the appearance of which helped him to guess what the *pâte de verre*, or plastic glass, might have been. He then set to work and managed to produce a plastic glass out of which he succeeded to fashion several plaques and small figurines.

It is a *pâte de verre* into which (when in a cold state) nails could be hammered without injuring or altering the substance in any way. He exhibited at the Salon, in 1891, a *Circé*, being a bas-relief in plastic glass, 1 meter high and 35 centimeters wide, which may be seen now at the *Musée Céramique*. This already proved that his attempts had been somewhat successful. Yet a few defects in these various pieces indicated that he had not entirely mastered his new art.

Henry Cros is now in full possession of his process. He has been able, thanks to the help of the Government, which allowed him to work at the Sèvres manufactory, to produce with plastic glass a wall fountain (*fontaine murale*) formed of fourteen pieces so perfectly assembled that the fountain seems to be one piece. This remarkable fountain, which is 2 meters, 30 centimeters high, and 62 centimeters wide, has been designed, modeled, colored and baked by Henry Cros alone, and is adorned with figures, the ensemble of which symbolizes the history of water. The design is clear

and the execution is most satisfactory in every respect; the general outlines are



FOUNTAIN OF PLASTIC GLASS.

thoroughly harmonious and the colors have a soft and refreshing appearance.

We see at the top, at some distance in the

sky, Phœbus in a luminous car drawn by four white horses, passing across the signs in the Zodiac—the lion, the crab and the Virgo. He casts a glance at the mountain snow, symbolized by a young maiden partly nude, who in a chaste attitude, stretches one hand gracefully to shelter herself from the glaring sun. Her tunic or drapery, white and pink, in rolling down to her feet becomes a torrent, personified by a youth of a strong and energetic appearance, holding on his shoulder an urn out of which runs clear water forming a brook. An infant, sitting among flowers on the grass, endeavors in a playful way to stop with his hands the water of the brook, which falls as a cascade on rocks and stumps of trees. In the center of the basement, showing a course of foliage and vari-colored fruits, there is a large bearded mask, boldly modelled, symbolizing the river. From the mouth of that mask the water falls into a basin representing the sea, where we notice some shell fishes and a crab resting on a slimy ground among pebbles. There are also near the mountain snow a vulture and a bear, faintly modelled.

Human figures are rendered by Cros in every one of his works with an artistic excellence. The uncovered parts are delicately colored, all being calculated so that the light should deepen and warm up here and there the milky carnation. The lips are *vieux rose*; the apple of the eye is a drop of manganese or cobalt. The female figures are partly covered with a gauze veil of a yellowish sulphur color, sprinkled with dead gold spangles and showing mauve touches. Their features are refined and their limbs are very graceful.

This fountain in colored plastic glass will be exhibited at the next Salon.

E. E. Starr, jeweler, Bowling Green, O., has invented a novel water motor. It is made out of an old bicycle wheel, axle and hub, with ball bearing for the water wheel. On the outer rim are attached little cups on which a stream of water is thrown creating the power. It is encased in a galvanized iron casing so as to keep the water from being splashed all over the room. The power of the motor is used in running lathes, while it proves a novel window attraction.



**The Connoisseur.**

(Continued from page 39.)

**The Rambler's Notes.**

WHAT THE RAMBLER SAW AND HEARD AMONG THE DEALERS IN ART POTTERY, CUT GLASS, BRONZES, ETC.

NOVELTIES IN CARLSBAD CHINA.

IN the import samples of Bawo & Dotter's Carlsbad china, shown at their New York warerooms, 26-32 Barclay St., is an entirely new decoration, similar to the Sevres, which will surely prove a successful innovation. The plates and the novelties are ornamented with cupids or paintings of ladies prominent in the time of the Empire. An Empire green, red or yellow border completes the decoration, which is to be seen on fish, game, chocolate, desk and boudoir sets, plates, trays, etc. Among the new floral decorations are violet, lily-of-the-valley and white violet. A very pretty new shape, the "Flora," is to be seen in an assortment of brush and comb trays while another, "Monbijou," which has an attractive, irregular outline and embossed pink and gold border, is shown in a full line of the novelties handled by jewelers.

NEW LINES IN BOHEMIAN GLASS.

AMONG the lines to which Hinrichs & Co., 31 Park Place, New York, are devoting their energies,

Bohemian glass bouquet holders hold a prominent position. Their present assortment of these is richer and more extensive than any they have ever before shown, and includes many varieties particularly suited to the jewelry trade. Of these the principal is undoubtedly the line of large and small vases of many shapes and kinds, of white crystal, decorated with a gilt scroll and studded with real jewels. Various shapes and sizes in rainbow colors, may be seen opal glass, while a curious novelty may be found in the line of blue and pink glass having white tops of the shape of orchids or lilies. Attractive pieces are also to be seen in among the vases with white crystal bodies, and necks of shaped rosena, benema or amberina, which have gilt decorations. In another line the flower holders consist of violet colored tulips, these being entwined around a glass jar. This firm have also opened a complete line of Easter goods. In these they show bisque and papier-maché rabbits, chickens and comic figures with eggs, in great variety.

THE POPULARITY OF THE EMPIRE STYLE. THAT the Empire is now the reigning style in dress, decoration and artistic goods is known to every one who has seen the productions in these lines. A glimpse at the new Limoges goods of Chas. Ahrenfeldt & Son, at their New York warerooms, 50 Murray St., shows that the fad has extended to all pieces in

fine china, even to dinner sets. In this line, which comprises the largest and richest assortment that they have ever shown, the Empire style prevails throughout almost all the decorations. A full line of table, desk, boudoir and cabinet novelties, dinner ware sets, vases, flower holders, etc., is decorated with bust pictures of women prominent in French history, as Marie Antoinette, Frances Lamballe, Mme. de Pompadour, Louise La Valliere and others. Another line shows an old Empire style of decoration, consisting of festoons of flowers emanating from an irregular colored border of green, yellow or red. An exceptionally large and varied assortment of fine plates, individual sugars and creams, cups and saucers and vases shows many other attractive decorations.

The first consignment of new goods to Levy, Dreyfus & Co., shipped by their buyer, M. Liebman, is now to be seen in their art pottery department, at 9 Maiden Lane, New York. The goods consist principally of tea, coffee, chocolate, bouillon and after dinner cups and saucers of different English makes, in various decorations, principally floral. Some very pretty varieties of these, and sugars and creams, are in designs produced exclusively for this firm.

THE RAMBLER.

Always has a hand in it—the clock.—*Philadelphia Record.*

NEARLY A CENTURY OLD.

E. GÉRARD, DUFRAISSEIX & CO.,

SUCCESSORS.

FABRIQUE FONDÉE EN 1797



THE

CH. FIELD HAVILAND  
LIMOGES CHINA

IS MARKED:

WHITE WARE,



DECORATED



NEW GLAZE COLORS

(FURNACE FIRE),



HAVILAND & ABBOT, SUCCESSORS TO O. A. GAGER & CO. CHAS. FIELD HAVILAND & CO.

IMPORTERS OF CHINA,

P. O. Box 508.

29 BARCLAY STREET,

NEW YORK.

AGENTS FOR

E. GÉRARD, DUFRAISSEIX & CO.,

LIMOGES.

NEW YORK OPEN STOCK.

We carry at all times a large assortment of the "Chas. Field Haviland" china in white and decorated goods, to repack for immediate shipment or for sale in original casks. Have now sixteen open stock decors and are constantly adding new designs.

IMPORTATION SAMPLES.

The newest and choicest designs always to be found in our import rooms. Novel forms and tasteful decors.

New York Sample Rooms, - - No. 29 Barclay Street.



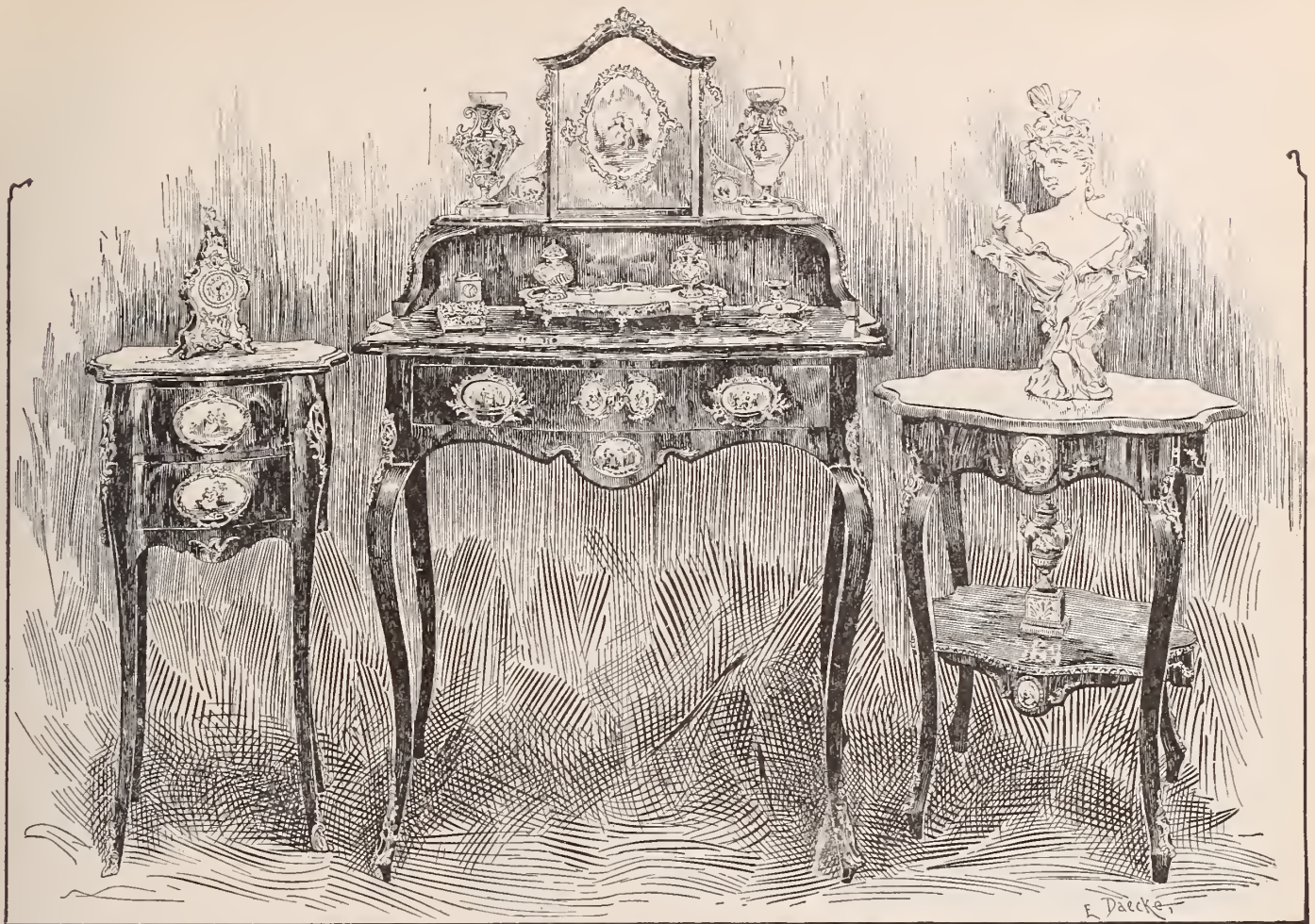

We now have an exceptionally fine display of

## DRESDEN - FURNITURE,

*Louis XV. Style, with "Watteau" decorations in Cabinets, Etageres, Tables, Escritaires, Chests of Drawers, Etc.*

## VENETIAN CARVED WOOD FURNITURE,

*Settees, Hall and Savonarola Chairs, Tete-a-tetes, Etc., in exclusive designs and at prices hitherto unknown.*

Attention is also called to *Buhl and Onyx Tables, Vernis Martin Cabinets*, and a general assortment of rich ornamental furniture.

Our collections of *Bronzes, Fine Bric-a-Brac, Cloisonne Goods, and Sevres Candlesticks* are superb, and include all the newest productions of the best European makers.

We hope you will give us an opportunity to show you these goods.

# GEO. BORGFELDT & CO.,

18, 20, 22 WASHINGTON PLACE, Cor. Greene St.,

NEW YORK.



# SUGGESTIONS FOR WINDOW AND STORE DECORATION.

Members of the trade who think they have an attractive window are invited to send us a photograph, or a pen and ink or pencil sketch of the same, which will be published if we consider the window contains any originality or lesson.

## IDEA LXVI.

THE accompanying illustrations show something novel in window fixtures which might verily be termed a triple Ferris

well balanced in order that it should run. The main rod runs on ball bearings to make the friction as little as possible. The small



AN INGENIOUS ARRANGEMENT OF FERRIS WHEELS.

wheel. The window is that of C. A. Schumacher, 46 Eighth Ave., New York.

The center wheel is composed of ten spokes, five of which are used to hang cars from to carry ring trays, the other five having rods with four hooks upon each to carry watches. This rod runs three inches outside, which also has small ball and hook from which little pans are suspended to display small articles, loose diamonds, etc.

The two smaller wheels on the sides are similarly constructed, with the exception that they have eight spokes and cars and four trays; they have rods to carry watches the same as the large wheel. The window is 6½ feet in width. The diameter of the center wheel in motion is 2 feet; of small wheels 1½ feet. The total weight of fixtures when dressed is about 50 pounds; but they could be made to carry two or three times the amount when evenly balanced.

In order to display goods in the store Mr. Schumacher has a duplicate tray to replace the one removed from the fixtures, as the main feature of the wheel is that it must be

rod from which the watches are suspended runs in small balls which are at the end of the spokes.

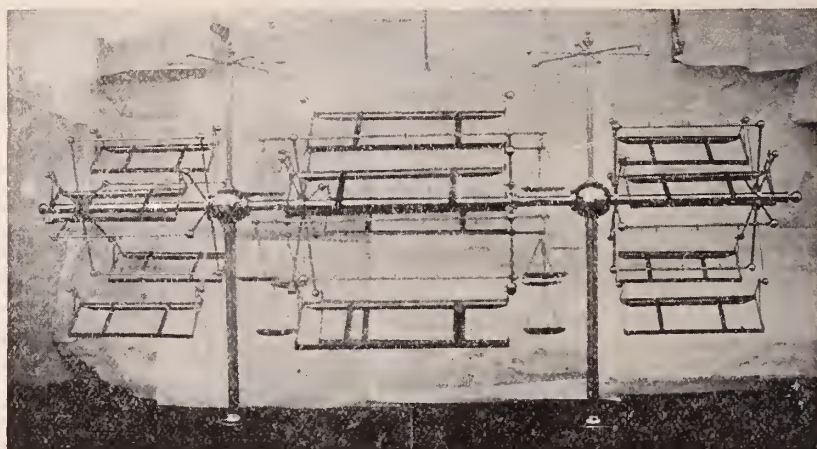

THE FRAME AND WHEELS.

The power to drive the wheels is obtained from a large movement which is placed

directly under the upright rod with beveled wheel.

The model was made by C. A. Schumacher, and constructed by Chas. Korpage, of 145 Fulton St., New York. The whole fixtures are of polished brass, and varnished. The wheels make about three revolutions a minute.

George Sigmund, of Sunbury, Pa., constructed a saw mill for his family's last Christmas tree that is an ingenious mechanism. Every feature of a saw mill is reproduced in miniature. Dolls dressed in overalls operate circular and band saws, roll logs with cant hooks, saw with cross cut, and in fact do all that a "really live man would do in a real mill." A four horse team drawing a wagon loaded with logs completes this unique and instructive toy. W. W. Fisher, the enterprising jeweler, has the mill on exhibition in his store window and the pretty sight draws crowds of people. The mill is operated by electricity.

## ACTOR WILLARD'S WATCH CHARM.

Some time ago in Philadelphia Mr. Willard was dining with some rather straight-laced persons. After dinner one of his watch charms—a 25-cent piece with an inscription on one side—was passed around the table.

"It was rather curious about that quarter," explained Mr. Willard. "One night when I was playing in 'The Middleman' it was thrown at me by a man among the gods during the scene where I am starving."

An old lady read the inscription, then dropped the coin like a hot coal.

"Really, Mr. Willard, you are positively blasphemous!" she exclaimed.

## IRONS & RUSSELL,

(SUCCESSORS TO CHARLES F. IRONS.)

MANUFACTURERS OF

SOLID GOLD EMBLEMS ROLL PLATE

PINS, CHARMS AND SOLID GOLD RINGS.

102 Friendship Street, - - Providence, R. I.



"Oh, but my dear madam," exclaimed Willard, "it was the engraver, not I, who was responsible for the capital G."

The inscription runs as follows: "To Cyrus Blenkarn, from a sympathic God." —*New York Evening Sun.*

"I believe in taking plenty of time, remarked the thief in the jewelry store, and he swiped several gold watches.—*Philadelphia Record.*



# HINRICHS & CO.,

29 AND 31 PARK PLACE, NEW YORK.

A COMPLETE LINE OF

## EASTER GOODS

JUST OPENED

Rabbits, Chickens and Comic Figures with Eggs  
in Fine Bisque and Papier Mache.

### BRIC-A-BRAC and ART POTTERY.

Doulton, Worcester, Royal Vienna, Teplitz, Dresden, Sevres, Coalport,  
Austrian Faience, Bisque Figures and Candelabras.

BOHEMIAN AND FRENCH CHRYSANTHEMUM VASES  
and Bouquet Holders, Atomizers, Cologne Bottles and Jewel Boxes.



No. 1347.



#### SPECIALTIES IN LIMOGES CHINA.

A. D. Cups and Saucers, Chocolate Cups, Teas and Coffees, Mustache  
Cups, designs and decorations entirely new and exclusively our own.

OUR SPRING STOCK was never more complete than now, and we never had a finer  
line of goods. These we will sell at greatly reduced prices for the next  
three months.

When you come to the city, don't fail to give us a call. Catalogues and Price  
Lists on application.



No. 1326/15.

### Jules Jürgensen

OF COPENHAGEN.

The reputation these watches have maintained for  
Fifty Years has never been equalled, being made  
on strictly scientific principles and no expense spared to  
give the Best results in mechanism and timekeeping  
qualities.

SOLE AGENTS.

John C. Hyde's Sons,  
NO. 22 MAIDEN LANE.

### "Old English"

Coffee Spoon.



DESIGN PATENTED.

Towle Mfg. Co.,

MANUFACTURERS OF

STERLING SILVERWARE.

NEWBURYPORT: No. 214 Merrimack St. CHICAGO: Nos. 149 & 151 State St.

ESTABLISHED 1870.

### J. L. CLARK,

SWEEP SMELTER AND REFINER OF GOLD AND SILVER.

Buys every kind of Gold and Silverware, Jewelry, Watches and Platinum. Full market value paid.

No. 724 Filbert Street, Philadelphia, Pa.

SEND BY EXPRESS or Registered Mail. If my price is not satisfactory, I will return all articles

### LIST REDUCED,

FOR 60 DAYS ONLY,

And STRICTLY for Cash With Order.

The List of the

### FRANCIS ENGRAVING MACHINE

Has been in some respects greatly reduced.

The Plain Bench Machine Reduced from \$75 to \$50.

For further particulars write to your Jobber or  
to the Manufacturer,

A. E. FRANCIS,

780 Cedar Avenue, Cleveland, Ohio.

February 15, 1894.

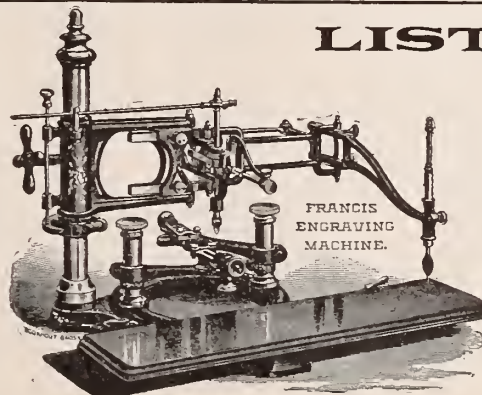

FRANCIS  
ENGRAVING  
MACHINE.

### "TIME IS MONEY"

SEND YOUR PRESCRIPTIONS  
AND REPAIR WORK WHERE  
IT IS DONE ACCURATELY WITH-  
OUT DELAY.

E. KIRSTEIN'S SONS CO.

SEND FOR CATALOGUE. ROCHESTER, N.Y.



Elk, Shrine and Masonic  
Emblems a Specialty.

Badges of Every Known Order.

G. A. SCHLECHTER,

Manufacturing Jeweler.

READING, PA

### For BADGES AND MEDALS

Flag Pins, Class Pins, Class Rings  
and Special Work of all Descriptions.

SEND TO E. R. STOCKWELL, MANUF'R.

19 John Street, New York





# B. & W. B. SMITH,

220 W. 29<sup>TH</sup> ST.,  
NEW YORK.

Dust Tight Wall Cases. Improved system of Shelving and Electric Wall and Counter Cases Lighting.

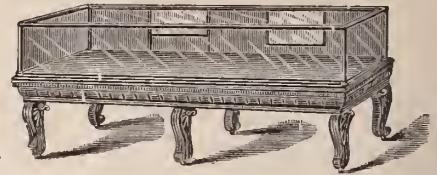

IMPROVED DUST TIGHT.

◁ SMALL CASES FOR SPECIALTIES ▷

ALL GLASS.

NO MOULDINGS

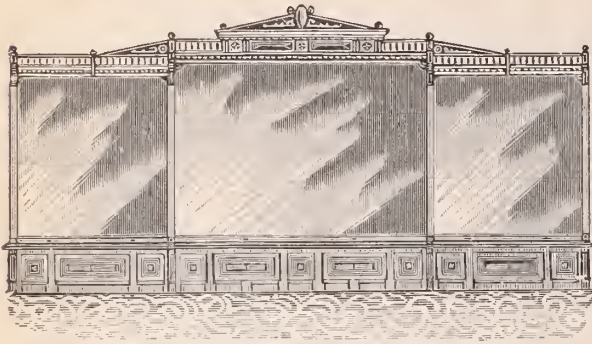

## The "Bryant" Rings.

Are widely advertised and will sell when anything will, therefore every Retail Jeweler should buy them.

IF NOT CALLED UPON BY OUR TRAVELERS  
ORDER DIRECT FROM

M. B. BRYANT & CO., 10 MAIDEN LANE, N. Y.

OLDEST RING MAKERS IN AMERICA.



S. C. JACKSON, 180 BROADWAY, NEW YORK.  
MANUFACTURER OF

Fine \* Cases \* for \* Jewelry, \* Silverware, \* Etc.

ALSO SHOW CASE TRAYS AND FANCY HARD WOOD WORK  
Samples sent on application. Estimates furnished

**PATENTS** SECURED WITHOUT FAIL OR DELAY.  
Send Rough Sketch or Model and I will tell you whether you can obtain a patent, WITHOUT CHARGE.  
Fifteen years' experience. Ample references. Address  
**C. T. BELT,**  
WARDER BUILDING, WASHINGTON D. C.

### S. F. MYERS & CO.,

WHOLESALE JEWELERS,  
MYERS BUILDINGS, - - NEW YORK.

1894 ISSUE, No. 38,

#### OUR ROYAL CATALOGUE

Illustrates all that is new, unique and desirable in everything that pertains to jewelry.

Sent free to dealers who have not received it.

TWENTY-TWO DEPARTMENTS.  
SEVEN DOUBLE FLOORS.

Myers Buildings, 48-50 Maiden Lane, New York,  
33-35 Liberty St.,

### S. P. HOWARD,

Gold and Silver Assayer.

Refiner and Sweep Smelter,

33 MAIDEN LANE, NEW YORK.

Smelting and Refining Works,

28 & 30 Cumberland Street, Brooklyn, N. Y.

Specialties: Sweepings, Gold, Silver and Platinum.

### J. SCHAWEL & CO., 29 John St., N. Y.

GOLD & SILVER REFINERS, ASSAYERS & SWEEP SMELTERS.  
STERLING SILVER, 925/1000 FINE IN SHEET AND WIRE.  
Soft Platinum, Sheet and Wire for Manufacturing Jewelers.

### WM. SMITH & CO.,

Manufacturers of Gold, Silver and Roll Plate Chains and Jewelry.



Novelties in Gold and Silver Bead Necklaces and Bracelets. Also a large line of Chain Trimmings and Silver Rings.

Office: 5 and 7 Maiden Lane, New York. Manufactory: 61 Peck Street, Providence, R. I.

FRENCH ENGLISH

CLOCKS AND HALL CLOCKS AND

MATERIALS. MATERIALS

CHAS. JACQUES CLOCK CO., 22 CORTLANDT ST., N. Y.

IT PAYS TO KEEP IN TOUCH WITH TRADE AFFAIRS, THE JEWELERS CIRCULAR, For 4c. a Week will do it. **Subscribe.**

1869-1894=Twenty-five Years, Oldest, Best, Brightest, Newest, =The Jewelers' Circular.





# THE JEWELERS' CIRCULAR

AND HOROLOGICAL REVIEW.

Copyright by THE JEWELERS' CIRCULAR PUB. CO.

189 Broadway, New York.

Entered at the Post Office in N. Y. as second-class matter.

VOL. XXVIII.

NEW YORK, WEDNESDAY, MARCH 7, 1894.

No. 5.

## A REMARKABLE HOROLOGICAL PRODUCTION.

**D**URING several days past considerable attention has been attracted in New York to a clock whose size alone is sufficient to make it an object of much interest. The piece is christened the Columbus clock and is illustrated herewith. It is the largest mantel clock ever exhibited in the United States, and is the product of Fd. & Ch. Pierre & Co., of Colletet and Paris, France, who exhibited it at the World's Columbian Exposition. It is now to be seen at the warerooms of their New York agent, 10 Maiden Lane. The clock is about four feet wide, over four feet high and weighs over seven hundred pounds. It is valued at \$2,000. The case is composed entirely of Algerian onyx, surmounted by figures and trimmings of real bronze, hand chased.

The figure at the top represents Columbus studying the globe. The face is copied directly from what is considered to be an authentic picture of the great discoverer. The picture in the gable or *fronton* depicting the caravels approaching land, is finely executed. In the center of the dial, in chased bronze, is a representation of the landing of Columbus and his reception by the Indians, reproduced from historical pictures. Outside this is a rim of onyx on which are the bronze numerals. The

onyx columns on both sides have handsome-ly chased bronze trimmings. Fine speci-



THE LARGEST MANTEL CLOCK EVER MADE.

mens of modeling are to be seen in the groups serving as side ornaments, each group showing a wild horse and his captor.

### Weighing a Hair.

**T**HE delicacy of the scales used in the mint is illustrated by the following, quoted from a contemporary. The refiner of the Assay office says:

"To number the hairs of your head is not a very difficult task. A very close approximation can be made by weighing the entire amount of hair on a man's head, and then weighing a single hair. The weight of the whole mass divided by that of one hair of average length will of course give the desired number. If you will pluck out a hair from your beard I can show you."

A long and straggling one was accordingly detached, the refiner putting it on a scale, which was inclosed in a glass case, and graduated with extreme accuracy.

With little weights of aluminum he piled up one arm until an equipoise was reached. The hair weighed three milligrammes.

"If you reduce this to figures," he said, "it would require eight thousand hairs to weigh an ounce, and suppose you have six ounces, you have forty-eight thousand."

We are inclined to think that a discussion on the truth of these statements admits of much hairsplitting.



# DEITSCH BROS.,

7 EAST 17TH ST., NEW YORK.

## LEATHER GOODS.

EBONY AND SILVER COMBINATIONS.

ORIGINATORS AND MAKERS OF

NOVELTIES IN LEATHER AND STERLING SILVER COMBINATIONS.



\*\*\*\*\*

**CROSS & BEGUELIN,**

17 MAIDEN LANE, NEW YORK,

ALL GRADES OF SWISS AND AMERICAN WATCHES, DIAMONDS, GOLD AND ROLLED PLATE JEWELRY, OPERA AND FIELD GLASSES, TOOLS AND MATERIAL.

SOLE AGENTS FOR THE **Rockford Watch Co.** MATERIAL.

MANUFACTURERS OF THE **Centennial Watches.**

SEND FOR OUR WATCH MATERIAL AND TOOL PRICE LIST FOR 1894.

\*\*\*\*\*

### AMERICAN SYNDICATE OF Jewelers' Auctioneers.

ESTABLISHED for the sole purpose of conducting sales for established Jewelers in the United States, Canada and Mexico. We do not sacrifice your goods. We take no sales on a percentage. Our terms are strictly one-half the profits realized on all goods sold. We guarantee you against any loss. We pay all our own expenses; we don't ask you to pay one cent of expense on our account. We buy stocks complete as well as sell them. If your stock is small, or your assortment is not complete, we will furnish from one to ten thousand dollars worth of any kind of stock you may need and in which you need not invest one penny. Don't make any arrangements with others until you read our pamphlet which we will send you free, giving you full particulars of our style of doing business, and the liberal offers we make to Jewelers. We don't care how small your stock is, we will furnish all the stock you need to make a successful sale. We challenge the world for any fairer or more liberal propositions than we make Jewelers. Don't fail to send us your address, and we will send you our business pamphlet, which gives you full explanations as to our terms and style of doing business. Address,

### AMERICAN SYNDICATE OF JEWELERS' AUCTIONEERS.

Offices: 20 WEST 14th STREET, NEW YORK. 611 PENN AVE., WASHINGTON, D. C.

### "THE BEST BUTTON MADE."

THE KREMENTZ

IN GOLD IN ROLLED PLATE

FROM FROM

**KREMENTZ & CO.** ONE PIECE **ALL JOBBERS**

AND ALL JOBBERS.

**COLLAR BUTTON.**

IS THE ORIGINAL ONE PIECE BUTTON IS STILL THE BEST AND STILL UNSURPASSED.

Sold by all wholesale dealers at manufacturer's price.

**A. N. CLARK,** PLAINVILLE, CONN.

Manufacturer of the Celebrated **LOOP WATCH KEY.**

The Best for the Price in the World. CROSBY'S JEWELING TOOLS IMPROVED.

Side of Square Stamped on each key.

Will quote royalty or price for the manufacturing of articles of real worth.

### CAMPBELL-METCALF SILVER CO.

Choice Conceits IN Sterling Silver ONLY.

2 Maiden Lane, N. Y., with Holmes & Edwards Silver Co. 66 Stewart St., Prov., R. I. Mills Bldg., San Francisco, 8th Floor, Room 1.

**JACOT & SON** IMPORTERS AND MANUFACTURERS OF **MUSICAL BOXES** 298 BROADWAY. NEW YORK



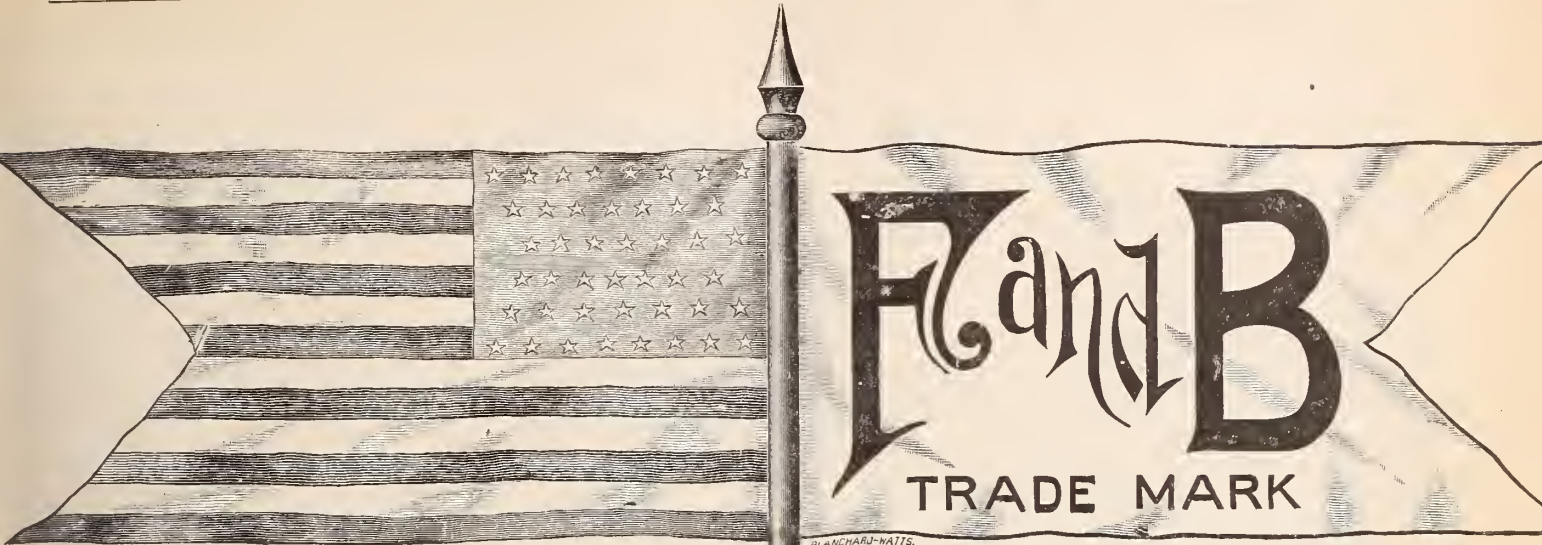

Our American F. & B.  $\frac{1}{10}$  Gold Chains will assay 10 K. 1-10 gold, and are guaranteed for ten years.

Our regular line of Chains is made of heavy gold plate, finely finished, and guaranteed for five years.



**Chains**  
Our new line of chains will assay 10 karat 1-10 gold. All gold soldered.  
**American F. & B. 1-10 gold.**

WE RECEIVED  
**4 MEDALS**  
AT THE WORLD'S FAIR.

Mount Hope Button.



CLOSED.

<p><b>Watch Chains for Gentlemen</b></p> <p>These goods are of fine quality, and guaranteed to give satisfaction. Some recently added have sold far beyond expectation. They are made of heavy rolled plate in all sizes and patterns.</p>	<p><b>Watch Chains for Ladies</b></p> <p>Our Victoria and Princess chains are neat and pretty. They are made in all bright, Roman and bright, platinum and bright gold, and have one or two charms.</p>
--	---

Mount Hope Button

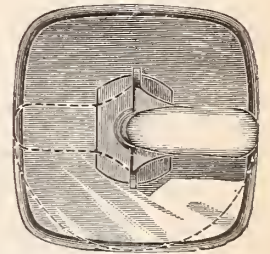



OPEN.

<p><b>Charms</b></p> <p>This line is adapted to ladies' or gentlemen's chains, and includes a number of heart charms in Roman, bright and satin finish, with stones and without.</p>	<p><b>Hair Chain Mountings</b></p> <p>In solid gold and rolled plate. We are headquarters and make everything desirable in this line.</p>	<p><b>Bracelets</b></p> <p>We make a large stock of curb bracelets in five sizes, besides the graduated links, with padlocks and snaps, in chased and plain polished, Roman, rolled silver plate and sterling silver. Also padlocks with keys and a push snap.</p>
--	---	--

<p><b>Pins</b></p> <p>Our large line of lace and cuff pins comprise many desirable patterns in gold fronts engraved and trimmed. Also includes baby pins and scarf pins.</p>	<p><b>"Mt. Hope" Buttons</b></p> <p>These are superior to any button in the world. They are easy to put in and easy to take out of the cuff.</p>	<p><b>Link Buttons</b></p> <p>This line has increased rapidly with us, and is very low in price, embracing all styles in Roman, chased, engraved and plain, with and without stones, and some in enamel.</p>	<p><b>Crosses</b></p> <p>We make four sizes of gold filled in plain, engraved and set with stones, and suitable for our neck chains.</p>
--	--	--	--

<p><b>Sterling Silver and Solid Gold Sword Scarf Pins</b></p>	<p><b>Glove Buttoners</b></p> <p>We make the interlocking and one with a twist handle in gold rolled plate and silver rolled plate.</p>	<p><b>Earrings</b></p> <p>This line includes many pretty patterns in gold fronts engraved, some with pretty trimmings and a small line of loop drops.</p>	<p><b>Neck Chains</b></p> <p>We make a variety of neck-chains in bright and Roman, with snaps.</p>	<p><b>Sterling Silver Bracelets and Padlocks</b></p>
---	---	---	--	--

	<p><b>Gold Locket Set with Diamonds</b></p> <p>These lockets are made of 10 karat gold throughout and set with brilliant diamonds. They cannot be surpassed in finish or cheapness of price.</p>	<p><b>Gold Locket Engraved</b></p> <p>These lockets are also made of 10 karat gold throughout, with beautiful designs engraved thereon and the price is so low that they cannot fail to be in great demand.</p>	<p><b>Gold Front Locket</b></p> <p>This line is very extensive. Many are nicely engraved, with and without stones.</p>	<p><b>Rolled-Plate Locket</b></p> <p>This line is almost endless, and consists of nearly every conceivable shape, size and style. Some are set with imitation diamonds, rubies and sapphires.</p>	
---	--	---	--	---	---

We have put upon the market a line of Gentlemen's Chains and Ladies' Chain Bracelets made of 1-10 gold stock. Every joint is soldered with gold, and every Chain or Bracelet will assay more than 1-10 gold. They are our AMERICAN F. & B. 1-10 GOLD goods, and are so stamped. Bar, Chain and Swivel are stamped 1-10 gold.

**FOSTER & BAILEY, Providence, R. I.**



# G. A. WEBSTER

42 & 44 Madison St., Chicago, Ill.

**Manufacturer,**  
AND WESTERN AGENT FOR

E. G. WEBSTER & SON, of Brooklyn, N. Y.

A. F. TOWLE & SON CO., of Greenfield, Mass.



61 Hanover Street, Boston, Mass.

Sales made for Jewelers only in their established places of business. Can give best references of any auctioneers in America.

All communications strictly confidential.

## Bids for Furnishing the Boston with Silver Plated Ware.

WASHINGTON, D. C., March 2. — There were only two bidders to enter proposals for furnishing the *Boston* with silver plated ware, in accordance with the recent invitation extended by the Navy Department for bids, reference to which was recently made in THE CIRCULAR. The Gorham Mfg. Co. bid \$176.75, and the Wilcox Silver Plate Co., \$168.58.

Bids were opened at the same time for furnishing cut-glass to several cruisers.

## The Jewelers of Nebraska to Form a Protective Association.

LINCOLN, Neb., March 2.—A meeting of the retail jewelers of Nebraska has been called to assemble in this city on March 14th and 15th for the purpose of forming an association for mutual benefit. Replies have been received from more than 100 jewelers who have signified their intention to be present. The headquarters of the association will be at the Hotel Lincoln.

The meeting is the result of a widespread feeling that the jewelry interests of the State have been suffering from competition which can be hardly classed as legitimate. One of the growing menaces to the trade is the extensive manner in which many large dry goods houses in the larger towns are going into the jewelry business. It is claimed that these houses carry jewelry, not for the small profit there is in the trade, but as a

means of drawing custom. The margin of profit is reduced to the minimum for the reason that the dealer can make up his losses from other departments.

## Lucy Gardner's Conviction Confirmed by the High Court.

TRENTON, N. J., March 1.—The Court of Errors and Appeals has decided by a vote of 7 to 5 to affirm the conviction of Lucy Gardner, the young society woman of East Orange, who, in 1891, was found guilty of larceny. Miss Gardner ordered some jewelry from Stern Brothers' store, New York. The case caused considerable excitement at the time. A package with a due bill of \$21.75 was sent. Miss Gardner took the box upstairs and returned in a few minutes saying there was only a piece of jet in it.

## An Old Dodge Worked Upon a Careful Jeweler.

WORCESTER, Mass., Feb. 28.—W. A. England is out a \$65 watch through an often-tried trick played on him last Saturday night. A young man named Goodell called at his store and represented that he was a member of a certain organization, and that he was one of a committee appointed to select a gold watch to be presented to one of the members of the fraternity. Goodell selected a watch and told Mr. England that he would like to take it to the remaining members of the committee for inspection. Mr. England was unsuspecting and granted the fellow's request.



179 BROADWAY, N.Y.

## OUR OWN ★ "COLUMBIAN"

Fifty Punch Staking Tool, LEADS ALL OTHERS in STYLE, FINISH and ACCURACY. Hundreds of practical Watch Makers pronounce it the BEST.

Nickel frame, mahogany base, extra fine tempered steel punches and stumps.

→ FULLY WARRANTED. ←

For full description send five cents in stamps, with business card, for New Catalogue of OVER ONE THOUSAND varieties of fine Watch and Bench Tools of OUR OWN MAKE, many entirely new.

O. W. BULLOCK & CO.,  
SPRINGFIELD, MASS.

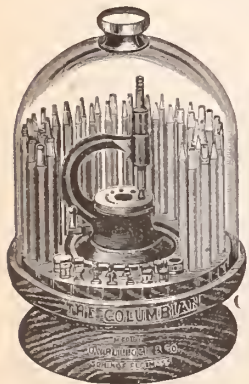

## VICTOR. ⊗ ⊗

SIMPLEST FEED. ALWAYS THE SAME.  
GUARANTEED FOR ONE YEAR.

## THE VICTOR FOUNTAIN PEN

(Pat. Feb. 4, 1890.)

THE BOSTON PEN CO.,

N. C. Whitaker & Co., Proprietors.

363 Washington Street, - Boston, Mass.,

Manufacturers of finest quality

TORTOISE : SHELL : AND : HORN : GOODS  
in every variety. Also Aluminum Hair Pins.

Send for illustrated Pen Price List No. 1.

WHITE'S EYE SHADE. W. B. WHITE & SON  
MANUFACTURERS OF



Spectacle and Eye Glass  
CASES

90 SOUTH STREET, BOSTON.

Special Cases made to order for Optical Trade. Cases for Trial Lenses. Opera Glasses recovered, etc. Chatelaine Spectacle Cases, Metal Bound Leather Cases for combs, scissors, etc. Over forty kinds of cases manufactured.

## THEODORE C. STEINHAUS,

— MANUFACTURER OF —

## Fine Cases and Trays

For JEWELRY, SILVERWARE, &c.

SAMPLE CASES AND TRAYS FOR TRAVELERS.

Fancy Hard Wood Chests for Silverware, &c.

Linings, Cushions, Mounting, etc., for Silver Novelties.

10 MAIDEN LANE, NEW YORK.



THE  
*Pairpoint*  
 MAKERS OF  
 Hollow and  
 "1880" Flat Ware.

**MFG. COMPANY,**  
 Gold and Silver Plate.

FACTORIES:  
 New Bedford,  
 Mass.

HEADQUARTERS FOR  
 RICH CUT GLASS.  
 COLONIAL,  
 ROYAL FLEMISH,  
 CROWN MILANO.  
 Decorated Art Glass.



No. 6300. ORANGE HOLDER.



No. 2697, EMBOSSED CANDLESTICK



No. 6301. ORANGE HOLDER.

SALESROOMS:

NEW YORK, - - 20 Maiden Lane.  
 CHICAGO, - - 224 Wabash Avenue.  
 SAN FRANCISCO, 220 Sutter Street.

**A. J. LOGAN,**  
 MANUFACTURER OF  
 WATCH TOOLS, HAIR SPRINGS AND  
**WATCH MATERIALS.**  
 < New Catalogue just issued, Sent on Application. >  
 WALTHAM, MASS.

**If Your Sales  
 Are Not Satisfactory**

ADDRESS  
**DE B. O. SCOTT,**  
 20 Murray Street, New York.  
 AUCTIONEER.

Specialties: Watches, Clocks, Bric-a-Brac, &c.  
 Write for particulars and references

AWARD AT WORLD'S FAIR, CHICAGO, 1893  
 The Providence Shell Works.  
**W. K. Potter,**  
 346 Westminster St., Providence, R. I.



W. K. POTTER,  
 TORTOISE SHELL WORKS PROV. R. I.  
 Tortoise Shell Goods, Combs, Hair Orna-  
 ments, Jewelry, Etc.  
 Shell Work made to order on contract. Repairing for  
 the trade in all its branches.

We sell to the legitimate Jewelry and Stationery  
 trade only.



**CHOICE PAPERS**  
 MAKERS OF  
**FINE STATIONERY**

For Correspondence, Wedding and Business Use, handsomely  
 boxed, specially suited to the Jewelry Trade.

18 MURRAY STREET, NEW YORK.



# R. WALLACE & SONS MFG. CO.

**SILVERSMITHS**

Trade Mark.



**R. W. & S.**  
Sterling.

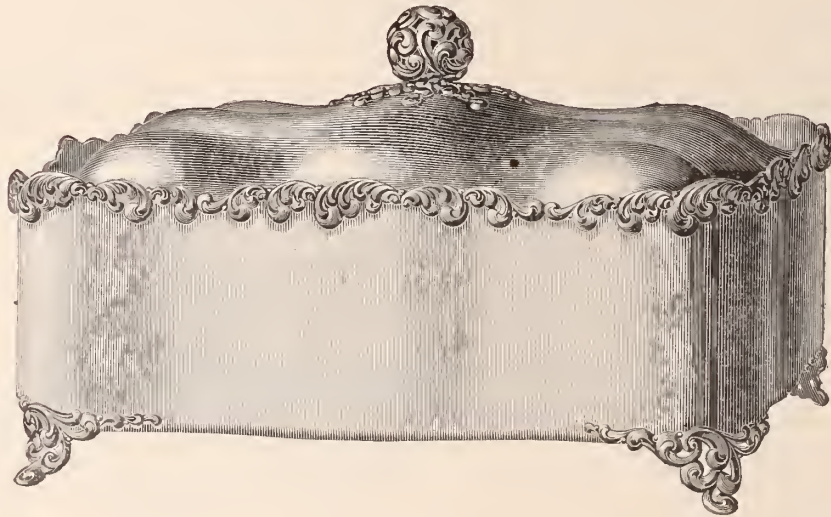

WAVERLEY SARDINE BOX.

Manufactories and  
Main Office,

WALLINGFORD, - - CONN.

BRANCHES :

NEW YORK  
3 PARK PLACE.

SAN FRANCISCO,  
120 SUTTER STREET.

CHICAGO  
86 WABASH AVENUE.



### Among the South African Diamond Mines.

ANNUAL MEETING OF THE DE BEERS CONSOLIDATED MINES—INTERESTING POINTS IN CECIL RHODES' SPEECH—THE TRUE "DIAMOND KING."

KIMBERLEY, Jan. 20, 1894.—The principal event of the week has been the annual meeting of the De Beers Consolidated Mines, Limited, at which C. J. Rhodes presided. The full weight of the importance that this concern bears upon the diamond industry throughout the world is now well understood, and the fact that it distributes in dividends to its shareholders in Europe and in this country with unfailing regularity the sum of close upon one million pounds per annum, has also a marked significance.

Mr. Rhodes made, in the course of a long speech, some interesting observations. He reminded them that prior to the amalgamation they had practically to sell their diamonds for what they could get, often for considerably less than the cost of production, while now they had so far regulated the industry that they had the power of demanding from the outside world a fair price for what they produced. They had further fortified their position by establishing a reserve fund of £700,000 which enabled the company to meet any check that might arise in the market. Buyers knew that they had this reserve and they could tell their retail customers at home that there was no chance of forcing the hand of De Beers and inducing them to sell their diamonds recklessly. In addition to this reserve they had three and a quarter million loads of "blue" on the floors which represented nearly four million pounds value. They produced about 200,000 karats per month, for which they were getting £270,000. This permitted, at present prices, of a profit of £120,000 per month, and if prices enhanced their profits would be much greater.

There were no people more desirous than the diamond buyers that they should get an increased price because it enables them to secure an extra profit on the retailing of the diamonds. The diamond buyers were always satisfied with a certain commission, whether diamonds were worth 26s., 30s. or 32s. a karat, but they rather preferred the higher price. What the De Beers Co. had suffered from recently, had been the unfortunate state of American finance. It was the policy of the company to maintain the market however, and to keep up prices by their own strong financial position. Their only risk was the sudden discovery of new mines which would no doubt work to the detriment of De Beers. But apart from this they had a fair prospect of continuing their strong position and of paying good dividends as hitherto. The remainder of the business was of a nature to convince one that the company is determined to maintain its policy of controlling the price of diamonds.



The Attention of the Trade is called to Our Line of

GENTLEMEN'S RINGS and SEALS,

with Intaglios, in Jade, Jasper and Carnelian. These goods are exceedingly desirable for this season's trade.

ALSO our full line of Misses' and Children's Rings finished in Roman.

OUR SPRING BACK STUDS, improved in construction, are now as near perfect as can be, and never so complete in variety of patterns.



Buy only the L. E. & Co. Stud.

## THE BOWDEN SEAMLESS RING

IS MADE ONLY BY

### J. B. BOWDEN & Co.,

Makers of Finger Rings of every Description.

COR. BROADWAY & JOHN STREET,  
NEW YORK.

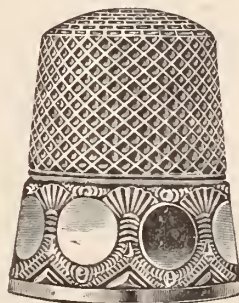

KETCHAM & McDOUGAL  
MANUFACTURERS  
GOLD & SILVER THIMBLES,  
GOLD COLLAR BUTTONS,  
AUTOMATIC EYE-GLASS HOLDERS  
198 BROADWAY N Y

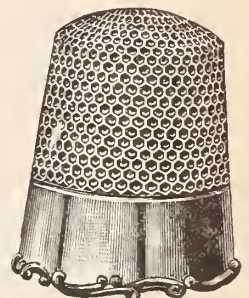

## IRONS & RUSSELL,

(SUCCESSORS TO CHARLES F. IRONS.)

MANUFACTURERS OF

SOLID GOLD EMBLEMS ROLL PLATE  
PINS, CHARMS AND SOLID GOLD RINGS.



102 Friendship Street, - - Providence, R. I.





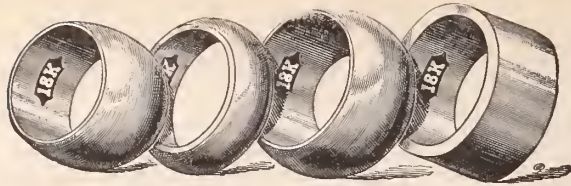

Band Rings metal lapped. Full value allowed for old gold.

## PLAIN SOLID GOLD RINGS. HILDRETH MFG. CO.,

53 MAIDEN LANE,

NEW YORK.

We Have Removed to ●●●●●●●●●●  
**57 MAIDEN LANE.**  
LEONHARDT & CURRAN,  
MANUFACTURERS OF DIAMOND MOUNTINGS.

# THE WARREN EYE PROTECTOR.

(Patented Jan. 12, 1892, Feb. 21, 1893.)

SAVES THE EYES FROM **Dust, Wind, or Glaring Light.**

FOLDS, IN A COMPACT CASE, IS

**COMFORTABLE, DURABLE, WATER AND DUST PROOF.**

Its large field does not obstruct the sight. No brittle substance to endanger face under sudden blows. Oculists and Physicians recommend it.

Travelers, Cyclists, Railroadmen, Horsemen, Motormen, Quarrymen,  
PRONOUNCE IT INDISPENSABLE FOR MAN OR WOMAN.

ASK YOUR DEALER FOR IT,

Colors, Clear, Smoke, Blue or Green. Black frames, 50c. Silver, 75c. Sent by mail on receipt of price. Manufactured solely by

The Nours Verrons Company, P. O. Box 3273,  
BOSTON, MASS.



355 Mulberry Street.

Newark, N.J.

## MARINE CHRONOMETERS,

MANUFACTURED BY

**John Bliss & Co., 129 Front St., New York.**

We have on hand a number of Chronometers, by various good makers, not new which have been in service for purposes of navigation, and are excellent instruments. They have been put in perfect repair and will give satisfactory results as to performance. We will sell these Chronometers at low prices, either for cash, or on accommodating terms to suit special cases, or will hire them at moderate rates and allow the hire to apply on purchase.

SEND FOR CIRCULAR GIVING PRICES AND TERMS.

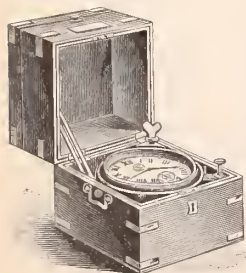

I have this week had a chat with J. B. Robinson, who more than any other man, merits the title of "The Diamond King," and he related many things about the discovery of these fields that have never yet been presented to the public. Mr. Robinson, now one of the richest of South African millionaires, was in prosperous circumstances when the news spread of O'Reilly's find in 1867, and immediately trekked here from the Free State bringing 1,500 cattle. This aroused the natives who began a surface search. They would not take money for the stones they found, and Mr. Robinson gave them an ox or a cow, sometimes a wagon and oxen, for the diamonds they brought him. In six weeks they found him diamonds which afterwards realized £10,000. This was months before any other white man arrived on the scene.

ST. GEORGE.

### Husband and Wife Die Within Forty-eight Hours of Each Other.

WOODSTOCK, Va., Feb. 28. — William H. Bargelt, an esteemed citizen and jeweler of this place, died last week, after a brief illness of bronchitis. He was born in Hanover, Pa., in 1828, and came here in 1849 and began his business at that time. Mr. Bargelt was a pillar in the Reformed Church here, he having been an elder for 30 years, and superintendent in the Sunday school for more than 40 years. He was a member of the Masonic and Pythian lodges. At the opening of the war he enlisted in the Stonewall Brigade, but subsequently became a member of the Seventh Regiment Cavalry Band, Rosser's Brigade, claiming the honor of being the only cavalry band in the service of the Confederacy.

As a sad and singular coincidence, the deceased's aged wife, who had been his inseparable companion for 40 years, expired upon her return from the funeral. Their only daughter now lies critically ill from nervous shock.

### The Jewel Was in His Mouth While Being Searched.

CAIRO, Ill., March 1. — William Pittman, assistant agent of the Illinois Central Railway at Pulaski, is in jail here charged with stealing a \$250 diamond ring from Edward A. Buder's jewelry store, last Saturday evening. He was standing near a showcase when the ring was missed and was at once accused, but denied the crime and invited a search. He held the diamond in his mouth and it could not be found.

Sergeant Fuller followed the man and found the ring in the snow. He was then arrested and confessed the theft, and also that he had stolen money and tickets from the company.

There is a legend about taking pennies from the eyes of a corpse, and now it is a woman of Michigan who sends to a Chicago optical house, an artificial eye of a dead husband, and wants allowance made for it toward a pair of new spectacles.



**Death of James F. Kelly.**

BROOKLYN, N. Y., March 3.—James F. Kelly, one of the oldest jewelers in Williamsburg, died of heart failure at his home, 141 Broadway, after an illness of ten days.

Mr. Kelly was born in New York city, in May, 1843. His father was Owen H. Kelly, a member of the jewelry firm of Nichols, Goodwin & Co., which was then one of the pioneer jobbing firms of New York city. Mr. Kelly was educated at the Jesuit college of St. Francis Xavier and from there went to St. Mary's, Montreal. When the war broke out he enlisted in Company A, Eighth New York militia. After the war was over Mr. Kelly secured a position in the appraiser's office in the custom house.

In 1869 he was married to Margaret E. Sutton from the house in which he died. Shortly afterward he started a jewelry business in the same building and conducted it up to the time of his death. Mr. Kelly was a member of Sts. Peter and Paul's Church and belonged to Mansfield post No. 35, G. A. R.; St. Francis Xavier alumni, Loyola union, Friendly Sons of St. Patrick, and besides this was treasurer of Transfiguration council, Catholic Benovolent Legion.

The funeral services were held on Monday morning at 10 o'clock from Sts. Peter and Paul's Church. The interment took place in the family plot in Calvary.

**A Woman Robs Jeweler Joss Right Under His Very Eyes.**

INDIANAPOLIS, Ind., Feb. 28. — Monday night about 7.30 o'clock a neat appearing woman, wearing a light colored fascinator and a dark, close fitting cloak, went into the jewelry store of Albert C. Joss, 80 Indiana Ave., and asked to be shown some rings. A tray containing plain rings was shown her, but she said she desired to purchase a diamond ring.

Several rings of this kind were shown her when suddenly she remarked she had to go on an errand and left the store, going south toward Washington St. Mr. Joss suspected that all was not right, and on investigating the contents of the trays found a valuable diamond ring missing. He immediately informed a patrolman who was only able to learn that the woman had last been seen on Illinois St., near Washington St.

**A Clever Swindler Said to be on His Way to America.**

PARIS, Feb. 26.—The Paris edition of The New York Herald says that a person calling himself Prince Toozcoswaren has succeeded in swindling French and German jewelers and other tradesmen to the extent of \$200,000, and has fled, it is believed, to America. Though it was supposed by many of his acquaintances that he was a spurious nobleman, inquiry has revealed the fact that he is a member of an old Belgian family.

His favorite method of obtaining the confidence of his victim was by industriously spreading the report that he was soon to marry a Russian princess of fabulous wealth. Warrants have been issued in Paris and Brussels for his arrest.

**An Excellent Showing.**

THE STEADY AND PROGRESSIVE ADVANCE OF A LIVE INSURANCE COMPANY.

The readers of THE CIRCULAR will learn with interest that the affairs of the Jewelers' & Tradesmen's Company, one of the best known life insurance organizations in the trade, are in a most prosperous condition. This is specially gratifying in view of the recent business depression and the present hard times and is due entirely to the push and enterprise of the present management. Such of our readers as are members of the organization may rest assured that the present gratifying state of affairs is an assured fact so long as the management of the organization's affairs is vested in the hands of the capable and experienced men at the helm to-day.

The annual statement just issued lies before us and shows policies in force amounting to the sum of \$4,000,000. On January 1, 1893, the company's books showed a business of \$3,210,000. To this sum there was added in new business during the year \$2,005,000, making a grand aggregate to March 1st of this year, of \$5,215,000, a record which any similar organization will find it difficult to equal.

At present over \$200,000 of new business is being written monthly and the company's total assets amount to the snug sum of \$32,000.

The Jewelers' & Tradesmen's Life Insurance Company offers a plan that is equitable in its treatment to all. An adequate reserve is accumulated, and the premium payments, which are as low as experience has taught is consistent with safety, may be made annually, semi-annually or bi-monthly, as may best suit the insured. A prominent feature of the plan is the method of accumulating and using the Reserve Fund. Twenty per cent. of the net amount received from mortuary payments is invested or deposited in trust for the benefit of contributors, except such amounts as may be needed for the prompt payment of valid death claims, the surplus remaining in the Reserve Fund, from which there is a dividend on the tenth year and each year thereafter, estimated to be equal to one-half the mortuary payments.

All certificates that have been in force ten years receive annually such equitable dividend from the surplus of the Reserve Fund as may appear to their credit for the first year of the series, thereby materially reducing payments on certificates after the tenth year, and at the same time avoiding the peril of a large accumulation of money without provision for its distribution.

As an evidence of the promptness and fair dealing of the Jewelers' and Tradesmen's Company in the matter of death claims the correspondence below since January 1 is self-explanatory:

Received from the Jewelers' and Tradesmen's Company of New York one thousand dollars (\$1,000), in full for all claims and demands under policy No. 372, issued on the life of my beloved husband, Karl F. Spitz, now deceased.

BABETTA SPITZ, 118 Pearl St., N. Y.

Office of McKesson & Robbins, N. Y.

Received from the Jewelers' and Tradesmen's Company, 187 Broadway, N. Y., policy No. 667, five thousand dollars (\$5,000), being settlement in full of death claim arising from decease of William E. Vennard, who was insured in your company for that amount. Thanking you for your prompt payment and courtesy towards Mrs. Vennard, I remain, yours cordially,

JOHN M. MCKESSON, JR.

*Jewelers' & Tradesmen's Company, 187 Broadway, New York City.*

GENTLEMEN—Please accept my most grateful thanks for your prompt payment to me of two thousand dollars (\$2,000), policy No. 435, the same being the full amount of the certificate of insurance issued by your company on the life of my late husband, John A. Clement. I take great pleasure in recommending your company to all who may desire protection for their families in the event of their being suddenly taken away. Too much praise cannot be given to the officers of the company for their courtesy and consideration towards me in my bereavement, and I heartily wish the Jewelers' & Tradesmen's Company the very best success, which I am sure they fully deserve.

Respectfully yours,  
HELMER CLEMENT,  
1177 Jefferson Ave., Brooklyn, N. Y.

Office of Easton & Rupp,  
421 Eleventh St., N. W., Washington, D. C.  
E. S. Johnson, Jr., Secretary Jewelers' and Tradesmen's Company, 187 Broadway, New York City.

DEAR SIR—Enclosed please find receipt in full for one thousand dollars (\$1,000) from Mrs. Bartlett, being the amount of policy No. 3,223 on the life of her husband, Mr. George Bartlett. Accept her thanks and mine for your prompt and satisfactory settlement of the claim. Yours truly,

WILLIAM B. EASTON.

Received from the Jewelers' and Tradesmen's Life Insurance Company of New York, five hundred dollars (\$500), in full payment of certificate No. 2,116, issued on the life of my father, William Nolan, now deceased. Accept my sincere thanks for your prompt payment of the claim.

MARY NOLAN,  
231 West 16th St., New York City.

The Jewelers' and Tradesmen's Company is officered by experienced and successful life underwriters, and its board of directors is composed of prominent New York business men nearly all well-known in the jewelry trade. Already the company is popular with the insuring public by reason of its business-like methods, the care exercised in the selection of its business and the promptness and liberality characterizing its dealings with members and agents alike. Last year witnessed the absorption by it of a prosperous minor company greatly to the satisfaction of its policy holders, and at the present time negotiations are about completed for the amalgamation of a much larger organization which sees in the methods and system of the Jewelers' & Tradesmen's Company that safeguard for the interests of its policy holders which it feels impossible to guarantee by itself. This is a high compliment indeed and should cause each policy holder of the Jewelers' & Tradesmen's Company to feel a proper pride in the officers and management of that organization. The home office of the Company is at 187 Broadway, New York.—Adv.



# Easter Novelty

BOOK MARKERS WITH FOUR (4)  
SOLID SILVER TOKENS, MOUNTED  
ON CARD BOARD WITH THE WORDS

**"EASTER GREETING"**  
STAMPED WITH STEEL DIE AT  
TOP.

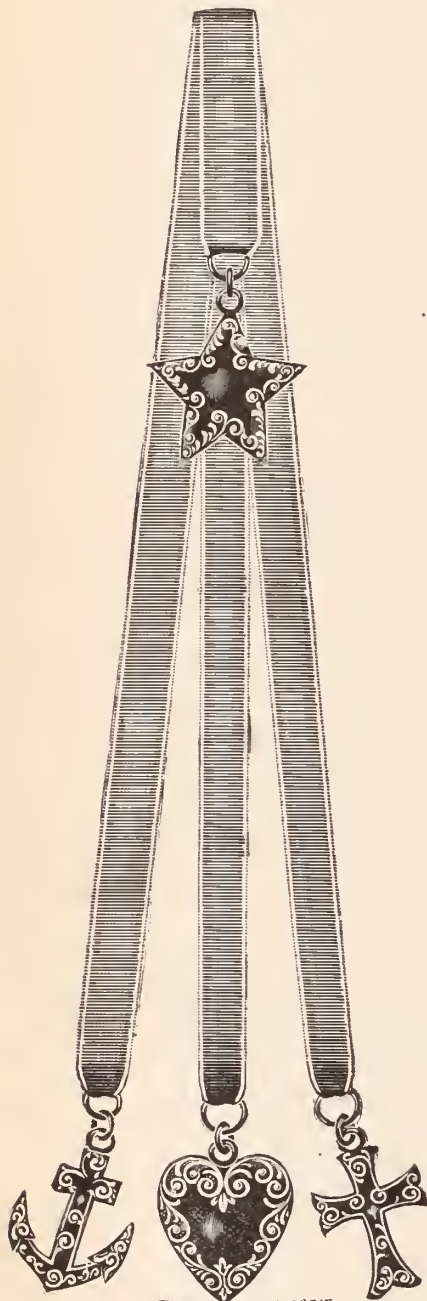

MADE JAN. 6 '94.

A QUICK SELLING AND POPULAR  
NOVELTY.

PLAIN FINISH,	PER DOZ.
EMBOSSED, SEE CUT,	\$5.00
EMBOSSED AND ENAMELED	9.00
	12.00

SEND FOR SAMPLES.

**QUEEN & CO.,**  
1010 Chestnut Street,  
PHILADELPHIA.

## The Sudden Death of Andrew Paul.

Boston, Mass., March 3.—Few events in recent years have created such a profound impression upon the jewelry trade of this city as the death on Tuesday last of Andrew Paul, the well-known senior partner of A. Paul & Co., 375 Washington St. Mr. Paul had been worried lately by depreciation in value of securities in which the funds of an estate of which he was trustee had been invested by him. Although they had noticed that he seemed very nervous and troubled, his condition did not cause his family any apprehension, but at 6.30 A. M. of the day named he was found dead in his bed. Hemorrhage of the brain is said to have been the cause of his death.

Deceased was 54 years and 10 months of age, and leaves a widow, two daughters and one son, Alfred J. Paul, who will leave Harvard, where he has been a student, and connect himself with the jewelry house.

Andrew Paul was born in Scotland and came to this country when a boy. He has always since then lived in Boston, obtaining his early education in the public schools and forming a business partnership here with his brother William, 22 years ago, after learning the business and keeping the books several years for the old firm of S. & J. Myers.

In the course of his long acquaintance with the Boston and New England trade he made numerous friends. He was widely known and highly regarded by his business associates, and among the Masons, Odd Fellows and other organizations to which he belonged took high rank as a most companionable man. He had been for a number of years a member of the executive committee of the National Association of Jobbers in American Watches.

Mr. Paul was always a welcomed participant in the gatherings of the jewelers, at dinners or social meetings, being an ardent lover of a good joke and a capital after-dinner speaker and story teller. At a meeting of the Boston wholesalers, jobbers and manufacturers held Wednesday at the office of Robbins, Appleton & Co., resolutions of respect were adopted and will be engrossed and presented to the family. Royal E. Robbins was chairman of the meeting, William H. N. Pratt, secretary, and the committee on resolutions included the secretary, with Austin T. Sylvester and James S. Blake. The meeting was a representative assemblage of members of the Boston trade, and it was voted to attend the funeral in a body.

Funeral services at the residence, 405 Marlboro St., took place Thursday at 11 o'clock. Among the floral tributes were a design from the clerks and salesmen of the firm and a mound of flowers inscribed "With sympathy of friends in the trade." The attendance of the jewelers at the funeral was very general, all the Boston jobbing houses being represented by one or more members of each firm. Prominent retailers came from other cities also, and New York, Attleboro and Providence manufacturers were represented.

## Traveling Salesman Berg Drowned While Sleighting.

MONTREAL, Can., March 3.—The members of the trade in Montreal and vicinity were much pained to hear of the sudden death by drowning of Henry P. Berg, of this city, which occurred near Prescott, Ont., on Monday last. Mr. Berg was traveling for the American Watch Co., Notre Dame St.

On Monday evening about 8 o'clock Mr. Berg and two other men left the Grand Trunk Station in a single sleigh to cross the St. Lawrence to Ogdensburg. They got off the track usually traveled by teams and drove into an air hole. The horse and sleigh went to the bottom in about 40 feet of water and two of the occupants were drowned. The bodies have not yet been recovered.

## Salesman Buitekan Turned in Fictitious Bills of Sale.

BOSTON, Mass., March 3.—Saul Buitekan, who has been a salesman for A. D. Cairns & Co., 386 Washington St., four months, was arrested Wednesday, charged with embezzling stock valued at \$1,000. He confessed his guilt. At police headquarters where he was searched officers found upward of 30 pawn tickets in his possession, and these enabled the owners to recover the property stolen.

A. D. Cairns & Co. do an instalment business, and Buitekan in his capacity as salesman turned in numerous fictitious bills of sale. Collections on these bills ran behind and his detection followed.

# EASTER GREETING.



Novelties

in

**Sterling Silver**

**BACHRACH & FREEDMAN,**

Silversmiths,

1 & 3 UNION SQUARE,  
NEW YORK.

Write for Samples.



### Bailey, Banks & Biddle Succeeded by a Corporation.

PHILADELPHIA, Pa., March 3.—The firm of Bailey, Banks & Biddle was dissolved on Feb. 28th, by limitation. The business of the late firm will be wound up by Joseph T. Bailey and Charles W. Bailey, who are authorized to settle and adjust all its business, and who will pay all the liabilities of the firm. Meanwhile Joseph T. Bailey, Charles W. Bailey, George W. Banks, Clement Weaver and Harry N. Robinson have applied for the organization of a corporation to conduct the business, and will continue it as heretofore under a corporation organized in accordance with the laws of Pennsylvania, under the name of The Bailey, Banks & Biddle Co.

Samuel Biddle, who for the past 16 years has had charge of the finances of the house, has dissolved his connection with the firm. He was 29 years in the business, having been well known as a partner in the house of Clark & Biddle, Robbins, Biddle & Co., and lastly of Bailey, Banks & Biddle.

### The Jas. H. Hart Corporation to be Dissolved.

BROOKLYN, N. Y., March 5.—The corporation of Jas. H. Hart, 539 to 543 Fulton St., one of the largest jewelry houses of this city, is in liquidation and a sale of the stock is now progressing. An application will be made to the Supreme Court in Brooklyn on March 13th for the voluntary dissolution of the company on the ground that they have impaired their capital.

A receiver will also be asked for. James H. Hart, the president of the company, who was seen at his store by a CIRCULAR reporter, Monday afternoon, stated that the company were perfectly solvent so far as the creditors were concerned, as their merchandise liabilities did not exceed \$5,000. The stock-holders, he said, would lose slightly, for the company have been losing money lately through the general dulness in trade. Mr. Hart holds four-fifths of the stock. The corporation owes him about \$40,000.

The principal reason for the dissolution, Mr. Hart said, is that he wished to close up the business, as he intends to retire. The closing of the business will in no way effect Mr. Hart's financial status. This firm is probably the oldest jewelry house in Brooklyn. It was founded by Jas. H. Hart, in 1855. Two years later Mr. Hart admitted his brother A. W. Hart, and the name was changed to J. H. Hart & Co. and later to Hart Bros. This firm dissolved in 1883 and J. H. Hart continued alone until 1889. The business was then incorporated with a paid in capital stock of \$50,000, and Mr. Hart became the president. The other incorporators were, Samuel T. Dauchy, Fred'k F. Dau, Geo. W. Dimmick and D. S. Southwick. The company are reputed to carry the most valuable jewelry stock in Brooklyn and are well rated in the trade.

### More Subscriptions Needed to Help the Needy Workingmen of New York.

The Executive Committee of the Jewelers' Relief Association met Wednesday afternoon. Among other matters taken up for discussion was the necessity of raising a larger fund, as the demands upon the association are continually increasing and the subscriptions have not kept pace with this increase. Geo. E. Fahys, Leopold Stern and Hayden W. Wheeler were appointed a committee to devise means for raising further funds. This committee decided that as assistance is given almost wholly to workmen in the trade it would be but fair to give the employes who are fortunate enough to have employment, a chance to assist their more needy confrères. Heretofore subscriptions had been solicited only from employes.

The following letter accompanied by subscription blanks has therefore been sent out:

NEW YORK, March 6, 1894.

DEAR SIR:—The urgent and daily increasing demands made upon our association has constrained us to make a further appeal to the trade in a manner not heretofore adopted.

Will you kindly see that the enclosed subscription sheet is presented to each of your employes, giving them the opportunity to subscribe to this worthy cause.

Please return the sheet with amounts subscribed to A. J. G. Hodenpyl, Treasurer, 170 Broadway, New York.

Very truly yours,

Executive Committee,

MAX J. LISSAUER,

Chairman.

The subscriptions received last week were: Black, Starr & Frost, \$100; Henry Hayes, \$25; Meriden Britannia Co., \$50; Rogers, Smith & Co., \$25; E. P. Reichhelm & Co., \$25; C. Langschmidt, \$10; Wm. Kinscherf, \$10; Cash, \$10; T. W. Adams, \$5; and Cash, \$5; in all \$265. This with the \$6,606.13 previously acknowledged makes a total of \$6,871.13.

### Death of Adolphe Grandjean.

BOSTON, Mass., March 2.—Adolphe Grandjean, jeweler and watchmaker, 1130 Tremont St., died this evening.

M. Grandjean was a native of Switzerland, and brother of the well-known watch manufacturer. He came to this country early in life and was a soldier in the war of the rebellion, in a New England regiment.

Deceased was prominent as a Mason and Odd Fellow and esteemed highly by the trade as an upright business man.

### Dynamite in the Engine Room of Kent & Stanley Co.'s New Building.

PROVIDENCE, R. I., March 3.—John Byron, foreman for Contractor Bishop, who is erecting the big new jewelry factory for the Kent & Stanley Co., found seven sticks of giant powder and dynamite by a newly placed engine to-day. There was also a fuse.

### Duty on Diamonds to be Reported to the Senate at 15 Per Cent.

WASHINGTON, D. C., March 3.—The Wilson Tariff Bill, as revised by the Senate Sub-Committee on Finance has been submitted to the Democratic members of the committee, preparatory to being laid before the full committee. Among the more important changes are the following:

Buttons, agate, are left unchanged. Pearl and shell buttons are changed from one cent per line and 15 per cent. ad valorem to 40 per cent. ad valorem.

The duty on unset diamonds is reduced from 20 to 15 per cent. ad valorem, and on set diamonds from 35 to 30 per cent. ad valorem. Diamonds in the rough are free.

Pearls are reduced from 15 to 10 per cent. ad valorem.

All cylinder and crown glass, which in the Wilson bill were taxed from 1 $\frac{3}{4}$  of a cent per pound up to 20 cents per square foot in the case of polished glass, are made dutiable whether polished or unpolished, at a uniform rate of 30 per cent., as also are all the manufactures of glass included in paragraphs 93, 94, and 95 which include plate glass of every kind, rough or finished, silvered or unsilvered.

Spectacles, opera glasses, and optical instruments are reduced from 35 to 30 per cent. ad valorem, as are also pebble or glass lenses.

Glass slides for magic lanterns and fusible enamel are reduced from 25 to 20 per cent. ad valorem.

Stained glass, irrespective of size, is made dutiable at 30 per cent. instead of 35 per cent. ad valorem.

In cutlery, pen and pocket knives are reduced from 45 to 35 per cent. ad valorem.

The sub-committee has changed the date when the law is to go into effect from June 1, 1894, to June 30, 1894.

### Charles I. Gardiner Commits Suicide.

PROVIDENCE, R. I., March 1.—Charles I. Gardiner, formerly a manufacturing jeweler in this city, committed suicide at his home, 21 Prairie Ave., last night, by taking poison while suffering from despondency brought on by advancing age and ill health. The unfortunate man was about 65 years of age and for many years has been a resident of this city.

Some time yesterday he purchased a preparation of prussic acid and cyanide of potassium and retiring to the bathroom early in the evening, swallowed the poison. He was found dead this morning by his son. He was very well known throughout this vicinity and was a prominent secret society member. He retired from the manufacturing jewelry business about seven years ago.

W. E. Cross, Amsterdam, N. Y., recently removed from the Sanford Block and opened a handsome new store at 38 E. Main St. Mr. Cross' enterprise was the subject of a short congratulatory article in the Amsterdam *Morning Sentinel* of Feb. 25th.



# Sterling \* Silver \* Belts.

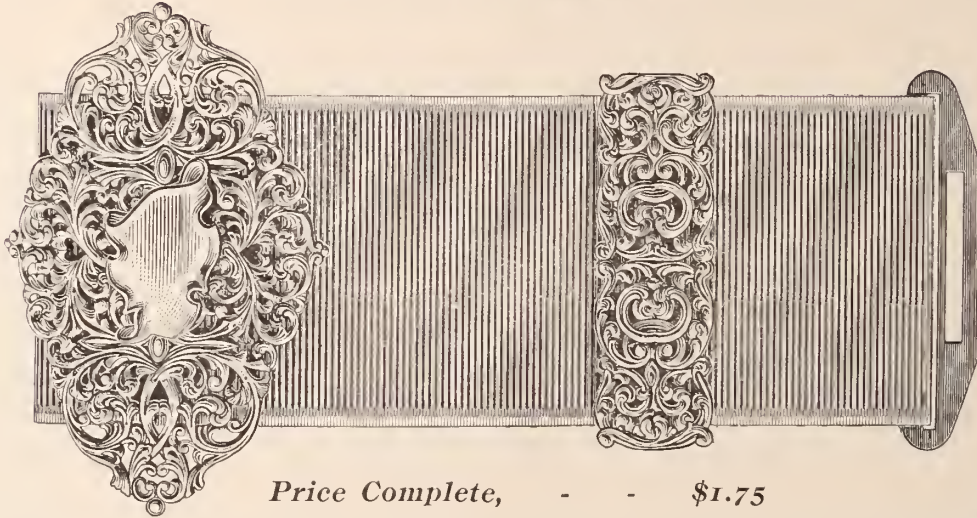

Price Complete, - - \$1.75

WE WERE THE ORIGINATORS OF THIS STYLE OF BELTS AND WE PROPOSE  
TO HOLD THE TRADE ON THEM.

We claim that our line of Belts (60 different patterns, all bright cut) are original and artistic in design and of best workmanship and finish, and we guarantee them to be much cheaper than any Sterling Silver Belts made.

The Buckles are mounted on the Finest Quality of Webbing, which we guarantee to be all Silk (no cotton filling) and full 20 line ( $1\frac{3}{4}$  in.) wide, and we are pleased to announce that from this date we are prepared to fill orders for any of our regular shades of Webbing with the MOIRE ANTIQUE finish as shown in illustration, without extra charge.

We Lead--Others Try to Follow.

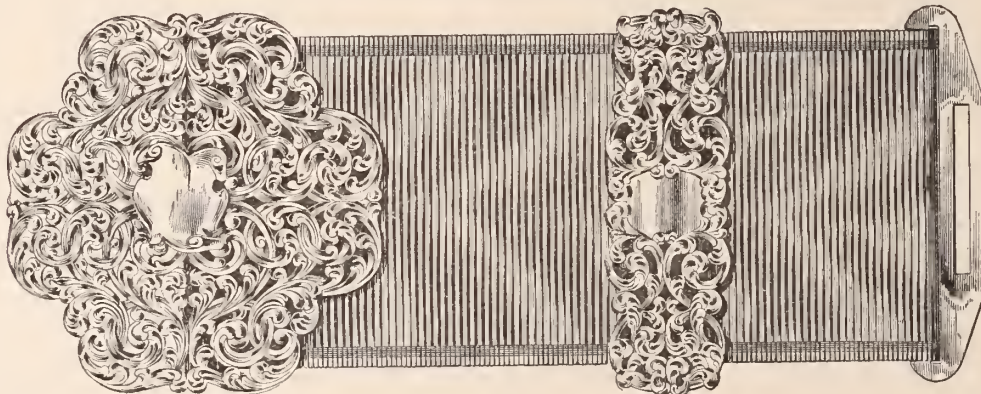

Price Complete, - - \$1.50

## UNGER BROS.,

.... MAKERS OF ....

Fine Jewelry in 14k. Gold and Sterling Silver, .925 Fine,

.... AT SALABLE PRICES ....

192 Broadway, = New York.



# The Jewelers' Circular

AND  
HOROLOGICAL REVIEW.

PUBLISHED EVERY WEDNESDAY BY  
**THE JEWELERS' CIRCULAR PUB'G CO.,**  
189 BROADWAY, NEW YORK CITY.

A JOURNAL DEVOTED TO THE INTERESTS OF  
JEWELERS, WATCHMAKERS, SILVERSMITHS,  
ELECTRO-PLATE MANUFACTURERS, AND ALL  
ENGAGED IN KINDRED BRANCHES OF INDUSTRY.

Our Editorial columns will contain our own opinions only, and we shall present in other columns only what we consider of interest or value to our readers. Advertising matter will not be printed as news.

Advertising rates in THE CIRCULAR are lower, considering the number of tradesmen reached by its large circulation, than in any other jewelry journal.

Notices of changes in standing advertisements must be received one week in advance; new matter can be received up to Monday.

## INFORMATION FOR SUBSCRIBERS.

### Terms of Subscription, Postage Prepaid.

	PER ANNUM
United States and Canada, . . . . .	\$2.00
Foreign Countries in Postal Union, . . . . .	4.00
Single Copies, . . . . .	.10

New subscribers can commence at any time.

Payments for THE CIRCULAR, when sent by mail, should be made in a Post-Office Money Order, Bank Check or Draft, or an Express Money Order or Registered Letter. All postmasters are required to register letters whenever requested to do so.

Pay money only to authorized collectors having proper credentials.

Returning your paper will not enable us to discontinue it, as we cannot find your name on our books unless your address is given.

In changing address always give the old as well as new one. Your name cannot be found on our books unless this is done.

We will continue to send papers until there is a specific order to stop, in connection with which all arrearages must be paid; but such an order can be given at any time, to take effect at the expiration of the subscription. All such orders will be promptly acknowledged by mail.

The Courts have decided that all subscribers to journals a responsible nonl arrearages are paid in full and an order to discontinue has been received by the publisher.

Member of the American Trade Press Association

VOL. XXVIII. March 7, 1894. No. 5

### The Future of the Jewelry Trade.

THE London *Spectator* has gone deeply into the subject of the future of the jewelry industry in England, though many of this influential journal's remarks apply with equal force to the trade in America. Referring to the industry, our English contemporary says: "There is little prospect of its dying away, except with a general decay of the whole trade of the country. The wearing of jewelry has its roots deep down in human nature—in the vanity of the sexes, in the admiration for color, in the permanent desire of mankind to break the monotony which tires the eyes. The growth of civilization has very little to do with the matter. In our own time it is the rich and cultured, and especially the kings, who are eager purchasers of precious stones, of fine gold work, and of silver, changed by the chaser's art into the semblance of another metal." The people with artistic taste and money are the goldsmith's most

## Spanish-American Edition of The Jewelers' Circular.

In our opinion, the tariff agitation, notwithstanding the changes that may be effected in the Wilson Bill by the Senate, will make it necessary for our manufacturers to seek a more extensive trade than they have heretofore possessed. The export field offers this opportunity. We all recognize the countries of Mexico, Central America, Cuba and South America to be a most desirable field for American manufactures.

With a view to bringing the productions in the lines represented by THE CIRCULAR more prominently before the dealers in jewelry, etc., in these countries, we will issue about March 28th an Export Edition of THE JEWELERS' CIRCULAR for circulation in the above countries, including all the jewelers of Mexico, Central America, Cuba and some of the large cities in South America.

This edition will be printed, both advertisements and reading matter, in pure Spanish, and will be finely illustrated. If you desire space in this number please communicate with us at once and rates will be made known upon application. Copy for advertisements is to be sent to us in English, which we will properly translate into Spanish.

Yours truly,

The Jewelers' Circular Publishing Co.

constant customers; and but for the expense, we should see the cultivated selecting gems as they now select china and Oriental needlework. They would love the pretty things as many jewelers learn to do. There will be no decay of the trade from any decay in the general appetite for their goods, which only seems to be feeble for a moment, because surplus money is a little scarce, or the apprehension of bad times unusually keen. In refutation of the idea that the love of ornament is essentially a feminine characteristic, the journal says: "There is a fallacy, we feel convinced, lurking in that explanation of the taste for ornament. The women feel it, it is true; that as beauty is more important to them than to men, they feel it a little more than men do, is also true; but that men are exempt from the feeling we do not believe." The *Spectator* thinks the real danger of the Birmingham jewelers' trade lies in Asiatic competition, but scouts the idea that the wearing of jewelry will ever cease, though fashion may decree for a brief space of time a lesser display of it. "The 'drift of the age' will effect a good many changes; but it will not greatly modify human nature, nor extinguish the desire of men to see women look pleased and full of the grace so true, though it be artificial, which beautiful ornaments impart."

### A Tariff for Revenue.

THE sub-Finance Committee of the Senate has been juggling with the tariff on diamonds and precious stones and the same problem faces the jewelry trade as existed before the Wilson Bill with the amended clause in reference to this duty passed the House of Representatives. A game of battledore and shuttlecock seems to be on foot. Give the matter one more toss back, but this time let it be back to the 10 per cent. which has existed for 40 years and which is the maxi-

mum duty on diamonds and precious stones that can be collected. If, as seems to be the case, the Senate will pass the bill only when it is in a shape that will provide for a tariff for revenue only, then let it leave unchanged the existing duty on diamonds, unless the revenue is to go to the pockets of unscrupulous smugglers rather than to the Government.

### The Week in Brief.

THE death occurred of Andrew Paul, Boston, Mass.—Last honors were paid to the memory of Sebastian Andersen, Chicago—The firm of Bailey, Banks & Biddle, Philadelphia, Pa., was succeeded by a corporation—George W. Gilbert, Pottstown, Pa., obtained an injunction against his employers, the H. M. Betz Jewelry Co.—The death occurred of O. A. Kvam, Minneapolis, Minn.—Still another silver goods factory is projected for Wallingford, Conn.—Cincinnati retailers organized a mutual protective organization—The New York, New Haven & Hartford R. R. Co. adopted a system of watch inspection—The window of the store of Mendel Lazarus, Brooklyn, N. Y., was smashed and robbed—The death occurred of James F. Kelly, Brooklyn, N. Y.—The E. Howard Watch & Clock Co. will produce a higher grade of watch—Henry P. Berg, traveler for the American Watch Co., Montreal, Can., was drowned—The jewelers of Nebraska will form an organization—W. H. Bargelt and wife, Woodstock, Va., died within 48 hours of each other—Suits were entered against Harry F. Legg, Minneapolis, Minn.—The Jas. H. Hart corporation, Brooklyn, N. Y., will go out of business—Changes were made in the Wilson Tariff Bill by the Subcommittee of the Senate.—Charles I. Gardner, Providence, R. I., committed suicide—The death occurred of Adolphe Grandjean, Boston, Mass.



### New York Notes.

A judgment for \$1,685.42 has been entered against Julia Hess, in favor of H. Levy.

The Meriden Britannia Co. have entered a judgment for \$2,251.43 against Geo. D. Smith.

R. Wallace & Sons Mfg. Co. have filed a judgment for \$711.38 against Julius C. Lulley.

The Gorham Mfg. Co. have obtained a judgment for \$98.25 against Laflin F. Kellogg.

Rubenstein Bros., 48 Maiden Lane, have taken offices in the Diamond Exchange, 14 Maiden Lane.

Geo. O. Street & Sons, 15 John St., have been elected members of the New York Jewelers' Association.

A judgment for \$226.69 against Gussie Grinspan and Pinkas Goldner has been entered by A. Davidoff.

Jos. Frankel's Sons will remove May 1st from 1 Maiden Lane to the Sheldon building, Nassau and John Sts.

M. Rubbo, 205 Union Ave., Brooklyn, has transferred his jewelry business to G. Garons for a nominal consideration.

Downing, Keller & Co., 8 Maiden Lane, have taken an office in the Stevens building, to which they will remove May 1st.

The *Commercial Advertiser* of Feb. 28th, contained a complimentary note regarding Leopold Stern, of Stern Bros. & Co.

Dattelbaum & Friedman have entered judgment against Sigmund Foder for \$620, and against Herman Harris for \$156.

Arthur Kreusser, 1215 Third Ave., has renewed a chattel mortgage on jewelry fixtures for \$3,780, held by M. D. Kreusser.

B. Folkart, 473 Fulton St., Brooklyn, has given a chattel mortgage on his jewelry store to J. W. Block & Bro. for \$450.

Herman Tax, 727 Grand St., Brooklyn, has been succeeded by R. Rifkin, who continues the business at the same address.

The judgment for \$102.17 which G. W. Schumann's Sons entered Dec. 20th, 1893, against Alice J. Phyfe, has been satisfied.

The Crescent Watch Case Co. have entered a judgment for \$259.37 against Robert Appleton, Jr., a real estate broker of Orange, N. J.

The Alpha Club, composed of employees of the Ansonia Clock Co., recently gave a masquerade reception at Park Circle Hall, Brooklyn.

The business of Sam. Younger, lately a jeweler at 375 Manhattan Ave., Brooklyn, who died two weeks ago, is being continued by his widow at the old address.

James Kahn's Sons, importers of diamonds, and Arthur J. Kahn & Co., jobbers in watches, on March 1st removed from 21 Maiden Lane to the third floor of 182 Broadway.

The store on the ground floor of the new building at 45 Maiden Lane, has been rented by E. A. Freeman, the receiver of the E. N.

Welch Mfg. Co., and the New York office of the company will be removed to that address May 1st.

Judgments were entered Thursday by Horowitz & Hershfield against the following: Abraham Grinspan for \$104.54; Ida Grinspan, \$204.85; Isaac Lewis, \$224.89 and \$246.91; Emanuel Stransky \$175.50 and \$96.26, and Jacob Unger, \$141.37.

Geo. W. Smith & Co., designers and manufacturers of artistic clock frames, furniture, etc., at 3907 Powelton Ave., Philadelphia, Pa., have opened a New York office and salesroom at 818 Broadway. The new office is in charge of H. P. Vollmer.

The Udall Co., of this city, have been incorporated to manufacture and sell articles in silver, with a capital stock of \$2,400. The directors of the company are: Chas. F. Udall, Chas. M. Slater and Roswell M. Udall, all of New York city.

Stern Bros. & Co., on May 1st, will remove their offices from the store they have occupied for over 18 years, at 30 Maiden Lane, to the Sheldon building, John and Nassau Sts. They will occupy the entire first floor of this building, and their new offices will be among the largest and most commodious in the trade.

A commotion was caused on Broadway in the vicinity of Maiden Lane, Saturday morning, by four Chinamen in full court dress, who alighted from a carriage in front of No. 176. In the party were the Chinese Minister from Washington, the new Chinese consul of this city and an interpreter who had entered the store of E. A. Thrall to purchase some watches. Their strange dress attracted an enormous crowd, which temporarily stopped traffic on the east side of Broadway.

Fd. & Chas. Pierre, of Paris, who are among the largest and best known clock manufacturers of France, have appointed Wm. H. Atwater their sole representative for the United States and Canada. Mr. Atwater opened his office March 1st, at 10 Maiden Lane and the New York office of Fd. & Ch. Pierre was then removed from 12 Warren St. to that address. Mr. Atwater will also handle an assortment of American clocks, selected from the products of the leading manufacturers.

The sheriff has received an attachment for \$2,324.15 against the Craighead & Kintz Co., manufacturer of lamps, bronze goods, &c., at Boston and Ballardvale, Mass., with a sales agency at 33 Barclay St., New York, in favor of Horace Craighead, for money loaned between July 1, 1892, and Feb. 13, 1894, and salary as manager. The sheriff levied on the stock of goods in New York, belonging to the company. Horace Craighead said that the company was not in any financial difficulty. He has incorporated a new company under New Jersey laws, called the Craighead Mfg. Co., with a capital stock of \$120,000.

Judge Wheeler, of the United States Circuit Court, Thursday handed down his decree in the suit of Wm. Mack against

Levy, Dreyfus & Co., which he recently decided in favor of the plaintiff. The decree adjudges that the defendants have infringed two claims of Mack's patent on his opera glass holder, and by it the defendants are enjoined and restrained from making holders covered by these claims. The complainant is to recover from the defendants, the profits, gains, etc. which have accrued from the infringement and the case is referred to Jos. M. Denel, a master in chancery, to ascertain and report what these profits and gains amount to.

It was learned last week that a part of a valuable gold cup which Tiffany & Co., are making for a customer in California, was stolen from their factory at Prince and Mulberry Sts., Monday Feb. 26th. The part is worth \$3,000, and the cup when completed, it is said, will be worth about \$25,000. A number of workmen were assigned to the task of building it in sections. Monday, when the men quitted work in the evening, one of the pieces was locked up in a cupboard in one corner of the work-room instead of the safe. Tuesday morning this piece was missing and it was discovered that the lock of the cabinet had been picked. The matter has been placed in the hands of the police.

In Part I of General Sessions, Thomas Powers, whose real name is Joyce, Feb. 27 pleaded guilty of grand larceny and was sentenced to two years in State's prison by Judge Martine. On Jan. 31st at James Slip, with a pal named Kelly, he picked a gold watch worth \$150 from the pocket of H. N. Squire, 18 John St. Joyce was captured and Kelly escaped with the watch. Mr. Squire's son, on Feb. 21st, received the watch from Kelly, accompanied by a note stating that Joyce was innocent. Kelly was arrested Feb. 26 and the following day was discharged from the Tombs Police Court, as he could not be identified. The same day Joyce or Powers pleaded guilty and was sent to prison.

A joint circular from Vacheron & Constantin, of Geneva, and Chas. Leo Abry, New York, informs the trade that the contract heretofore existing between the parties having expired, it was not renewed. Vacheron & Constantin have since issued another circular announcing that they have entrusted the agency for the sale of their watches in the United States and Canada to Edmond E. Robert, 21 and 23 Maiden Lane, New York. Chas. Leo Abry will soon announce to the trade that he will import a fine watch, and he will certainly keep the liberal patronage of his numerous old friends. The new comer, Edmond Robert, being the son of an old veteran in the watch trade and backed with capital and advisers as he is, can hardly fail to succeed. We wish success to all these gentlemen interested in their respective commercial ventures.

The sheriff, Monday, took charge of the place of business of Henry Blog, diamond cutter and polisher, 100 Nassau St., on a confessed judgment for \$518, in favor of



**L. TANNENBAUM & CO.,**

IMPORTERS AND CUTTERS OF

**DIAMONDS • AND • PRECIOUS • STONES.**

Cor. Maiden Lane & Nassau St.,

NEW YORK.

25 HATTON GARDEN,  
LONDON.

TELEPHONE,  
Long Distance,  
1959 CORTLANDT

IN ORDER TO REDUCE OUR ENORMOUS STOCK WE OFFER THIS WEEK AT  
SPECIAL PRICES, THE FOLLOWING GOODS :

Rough Siam Rubies for cutting purposes, at 50c. per karat.  
Rough Fancy Sapphires for cutting, at 25c. per karat.  
Rough Sapphires for mechanical use, and precious  
stones for collections.

We also offer at special prices, the following goods :

**SAPPHIRES.**

1 Sapphire, 3 kt. 47, . . . . .	at \$30.00 per karat.
1 " 3 kt. 47, . . . . .	at 65.00 "
1 Cabochon Sapphire, 3 kt. 44, . . . . .	at 25.00 "
24 " " fine Ceylon, 15 kt. 44, . . . . .	at 22.00 "
5 " " 6 kt. 1-32, . . . . .	at 25.00 "
22 Ceylon Sapphires, 29 kt. 22, . . . . .	at 45.00 "
47 Small Ceylon Sapphires, 8 kt. 21, . . . . .	at 4.00 "
Fine Sapphires, 36½ kt. 1-32, . . . . .	at 12.00 "
6 Cabochon Sapphires, 10 kt. 3, . . . . .	at 8.00 "

**RUBIES.**

1 Fine Cabochon Ruby, 1 kt. 26, . . . . .	at \$ 5.00 per karat.
1 Ruby, 1 kt. 1, . . . . .	at 75.00 "
1 " 2½ kt. 1-64, . . . . .	at 18.00 "
1 " 1 kt. 34, . . . . .	at 30.00 "

1 Cabochon Oriental Ruby, 3 kt. 37, . . . . .	at \$25.00 per karat.
65 Rubies, 38 kt. 7/8, . . . . .	at 30.00 "
19 Cabochon Rubies, 19 kt. 4, . . . . .	at 12.00 "

**SPINELS.**

1 Spinel, 1 kt. less 1-64, . . . . .	at \$ 3.00 per karat.
1 " 1 kt. 3-64, . . . . .	at 45.00 "
1 " 7/8 kt., . . . . .	at 30.00 "

**EMERALDS.**

1 Emerald (cushion shape), 1 kt. 13, . . . . .	at \$50.00 per karat.
1 " 3½, 3-64 kt., . . . . .	at 10.00 "
1 " 1 kt. 1-16 . . . . .	at 7.00 "
1 " (fine cushion), 2 kt. less 1, . . . . .	at 40.00 "

**PEARLS.**

1 Pearl, 10¾ grains, . . . . .	at \$10.00 per grain.
1 " 20¾, 1-16, grains, . . . . .	at 12.00 "
1 " fine black, 16½, grains, . . . . .	at 50.00 "
1 " Necklace, 325¼ grains, . . . . .	for \$2,200.00

**CATSEYES.**

1 Catseye, 13 kt. less 4, . . . . .	at \$24.00 per karat.
1 " 5 kt. 28, . . . . .	at 20.00 "

**ROGERS, SMITH & Co.**

UNION SQUARE,  
NEW YORK.

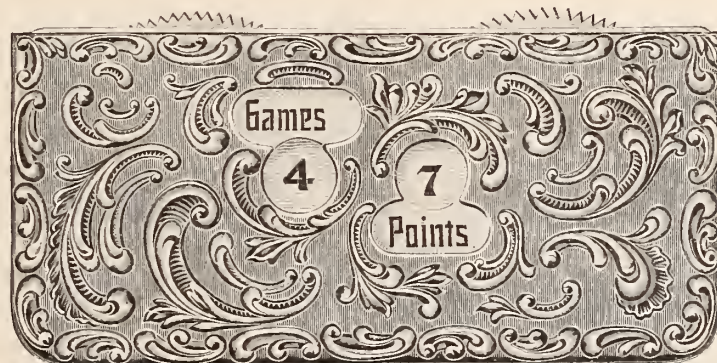

WHIST COUNTER.

MERIDEN,  
CONN.

**GOLD AND SILVER PLATE.**



Maurice De Vries, for money loaned. Blog has been in business about four years. His liabilities are said to be small.

James L. Ely has entered a judgment for \$898.25 against the Manhattan Watch Co. The judgment was obtained in a suit by Mr. Ely, for salary and commission on watches sold to the New York *World* some years ago.

**Dealers Object to Their Diamonds Having a Jaundiced Look.**

The change in the color of the front of the buildings, 5 and 7 Maiden Lane, New York, from an indefinite dark color to an orange yellow has brought forth a protest from the diamond dealers in the vicinity. The two numbers comprise one building but are owned by separate parties, No. 5 belonging to the Hoffman estate and No. 7 to Mrs. Elbridge T. Gerry. The dark yellow reflection from the new color completely spoils the offices opposite, as in the light reflected from the building the whitest brilliant has a yellowish appearance.

A meeting of some of the diamond firms thus affected was held in the office of Henry Dreyfus & Co., 4 Maiden Lane, Friday afternoon. Among the firms represented were Low, Weinberg & Co., Max Freund & Co., J. T. Scott & Co., Wallach & Schiele and Henry Dreyfus & Co., who passed a resolution requesting the owners of the Gerry building to remove the offensive color at once, the petitioners agreeing to bear all the expense of putting on a different color. Their petition also set forth in strong terms that business was being badly damaged, and that a change must be effected at once.

The Wilcox Silver Plate Co., 6 Maiden Lane, have also agreed to share in the expense of altering the color if the owners consented to do so. The light gives the stock a tarnished appearance from the

rear. A committee consisting of S. C. Scott and Louis Schiele visited a representative of the Hoffman estate Saturday, and were told that the matter would be investigated.

The firms most affected are Wallach & Schiele, and Low, Weinberg & Co., 8 Maiden Lane, in whose offices everything seems to have a yellow tinge; though the reflection extends down to the office of Henry Fera, at 10 Maiden Lane, and even into that of H. C. Hardy & Co., at 12 Maiden Lane. Many other firms are affected to a greater or less degree. Several state that it is impossible to sort diamonds in their offices, and unless the color of Nos. 5 and 7 is changed they will be forced to vacate their offices.

Something not only strange, but remarkable, comes from Yadkin County, N. C. An old clock owned by a farmer named Peter Shermer was years ago set aside as a worthless piece of property. It has not been known to run or strike until recently, when, to the great surprise of the family, it struck twice, and in just two weeks from that day a member of the family died. A few months later it struck twice again and in two weeks another member of the family died. Shortly afterward it struck twice again, and in two weeks the third member of the family passed away. The story is told by one of Yadkin's best citizens, who vouches for its truthfulness.

**ASSIGNMENT FOR THE BENEFIT OF CREDITORS.**

The general rule of law that a voluntary conveyance of personal property, valid by the laws of the state where made, passes the title wherever the property may be situated, is applicable in the case of voluntary assignments for the benefit of creditors.

*Covey v. Cutler, Supreme Court of Minn.*

**Last Week's Arrivals.**

*THE CIRCULAR* has perfected arrangements for obtaining the names and hotel addresses of all the latest buyers visiting New York, and each day posts in its office, 189 Broadway, a bulletin which every member of the trade is cordially invited to copy.

- The following out-of-town dealers were registered in New York during the past week: S. J. Leaback, Cork, Pa., Vendome H.; W. C. Ball, Cleveland, O., Astor H.; M. King, Boston, Mass., Plaza H.; D. A. Freeman, Boston, Mass., Murray Hill H.; R. Butler, Chicago, Ill., Astor H.; M. A. Stupp, Burke, Fitzsimons, Hone & Co., Rochester, N. Y., Park Ave. H.; S. Stern, Philadelphia, Pa., Morton H.; C. H. Hurlburt, Philadelphia, Pa., Gilsey H.; G. Kaufman, Pittsburgh, Pa., Gilsey H.; R. Mandel, Chicago, Ill., Imperial H.; G. F. Durgin, Concord, N. H., Holland H.; F. H. Williams, Philadelphia, Pa., Astor H.; A. A. Allan, Montreal, Que., Holland H.; G. A. Lee, Toronto, Ont., Astor H.; C. D. Tucker, Worcester, Mass., Astor H.; J. M. Harper, Philadelphia, Pa., Jefferson H.; J. E. Bird, Boston, Mass., St. Cloud H.; Mr. Forman, buyer for Spaulding & Co., Chicago, Ill.; S. Lubin, Philadelphia, Pa.; M. Eliassof, Albany, N. Y., Union Square H.; O. B. Dodge, Boston, Mass., Astor H.; C. Harwood, Boston, Mass., Metropolitan H.; J. T. Roth, Buffalo, N. Y., Grand Union H.; D. H. Starin, Chicago, Ill., Marlborough H.; W. D. Upson, Waterbury, Conn.; J. Nelson, Boston, Mass., Grand Union H.; A. Schaub, Detroit, Mich., St. Stephen H.; A. Eaves, Montreal, Que., Astor H.; S. Frenkel, Toronto, Ont., Imperial H.; R. R. Smith, Washington, D. C., Astor H.

WE DO NOT CLAIM THAT OURS ARE THE "CHEAPEST" OR THE "LIGHTEST WEIGHT" GOODS IN THE MARKET, BUT WE STILL ASSERT THAT OUR STERLING SILVER BELTS ARE UNRIVALED IN LOW PRICES, EXCELLENCE OF FINISH AND ARTISTIC CONCEPTION.

\$1.75 for this Belt Complete.

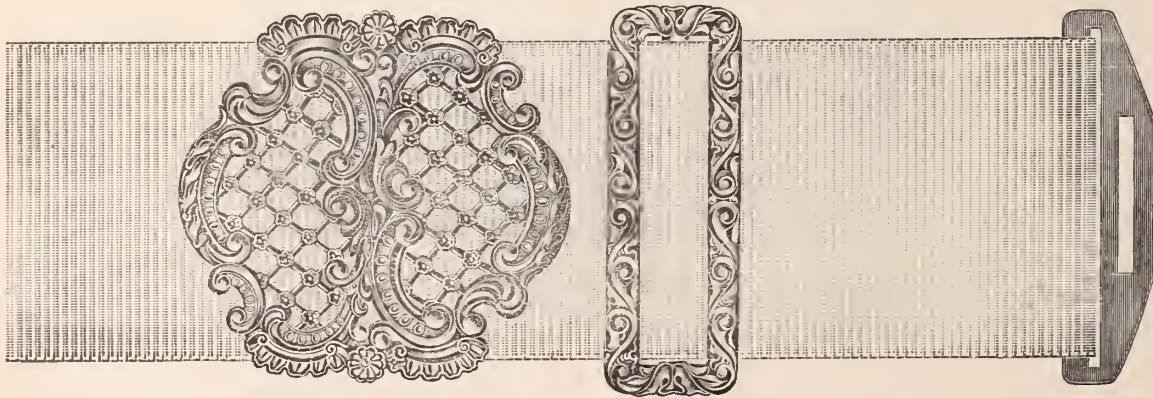

\$1.75 for this Belt Complete.

Bright Cut STERLING Silver (no filling), Mounted on Highest Grade of Imported Silk Webbing. An endless variety of patterns,

**JNO. W. REDDALL & CO.,**  
107 HAMILTON ST., NEWARK, N. J.

Fourteen Karat Gold. and Sterling Silver Goods of superior make and finish, at salable prices.



MORE APPRECIATIVE PRESS COMMENTS

ON THE SILVER ANNIVERSARY OF THE JEWELERS' CIRCULAR.

We extend our congratulations upon the magnificent way you celebrate your twenty-fifth anniversary. May there be many more to celebrate.—*Associated Industrial Press.*

THE JEWELERS' CIRCULAR last week issued its twenty-fifth anniversary number, which in all of its details is a credit to both the jewelry trade and to the publishers of THE CIRCULAR.—*The Manufacturing Jeweler*, Providence, R. I.

A unique anniversary number is the February issue of THE JEWELERS' CIRCULAR, which, having reached its twenty-fifth year, celebrates the period with a "Silver Edition," happily suiting the color of its print to the occasion and to the branch of trade to which it caters.—*Journal*, New York.

THE JEWELERS' CIRCULAR, one of the liveliest trade publications in this country, celebrated the silver anniversary of its founding by D. H. Hopkinson, recently. In the twenty-five years of its existence it has met with an emphatic success in its chosen field.—*Press*, Philadelphia, Pa.

THE JEWELERS' CIRCULAR (189 Broadway, New York), with the current issue, reaches its twenty-fifth year, and commemorates the occasion with a "silver anniversary edition" of 60 pages of original matter. The number contains numerous special articles written by the highest authorities in their respective fields, and several partake of a popular nature.—*Standard-Union*, Brooklyn, N. Y.

The public rooms of several of the New York hotels are decorated with objects of ornament and utility which are notable for their costliness or rarity. Clocks are the specialty of several of the newer establishments, notably the Savoy, Waldorf, Plaza

and Imperial. The timepieces displayed at these were described at length in a recent illustrated article in THE JEWELERS' CIRCULAR.—*Hotel Mail*, New York.

THE JEWELERS' CIRCULAR published at No. 189 Broadway, New York, with the current issue reaches its twenty-fifth year, and commemorates the occasion with a silver anniversary edition. The number contains numerous special articles written by the highest authorities in their respective fields. Every line in the sixty pages of reading matter has been specially written for this number.—*Citizen*, Brooklyn, N. Y.

The Jewelers' Circular Publishing Co., of New York city, celebrated its silver anniversary by issuing one of the handsomest numbers gotten up by any publishing house in the country. It contained a source of information within its pretty covers. Its stories were humorous and interesting. One of the most interesting features was a history of that well-known house of Tiffany. THE JEWELERS' CIRCULAR is certainly one of the best edited and leading trade journals of the time.—*Gazette*, Elmira, N. Y.

THE JEWELERS' CIRCULAR, with the current issue, reaches its twenty-fifth year, and commemorates the occasion with a silver anniversary edition. The number contains numerous special articles written by the authorities in their respective fields, and several partake of a popular nature. The number is highly creditable in every respect.—*Sunday Call*, Newark, N. J.

In a railway station in Iowa is the following placard on the clock: "This is a clock; it is running; it is Chicago time; it is right; it is set every day at 10 o'clock. Now keep your mouths shut."

Enterprising Jewelers Catch On!



Jewish Shekel, Masonic Mark or Pocket Piece. THE LATEST AND BEST SELLING NOVELTY.

The mark is struck in coin silver; by using either the obverse or reverse of the coin, the back being the same in either case, and permitting of the purchaser's name, blue lodge, chapter and individual mark, with date of same being engraved thereon, as shown in cut above.

Price, without engraving, ONE DOLLAR. Engraved Mark, Dates, etc., 75c. EXTRA.

Liberal Discount to the Trade.

CHAS. G. WILLSON, MANUFACTURING JEWELER, READING PA.

FOR EASTER BOOK MARKS

IN STERLING SILVER.

50 Cents.

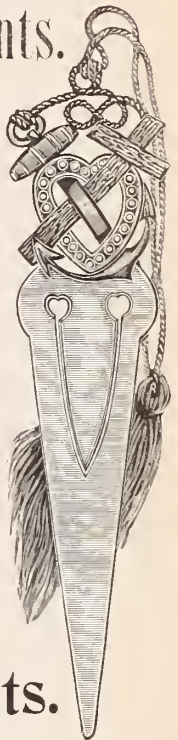
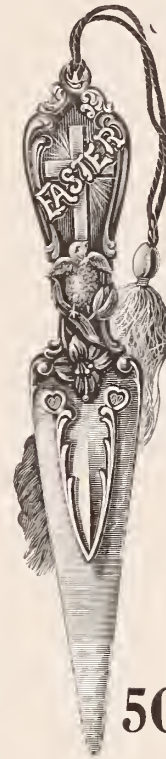

50 Cents.

ALVIN MFG. CO.,

...SILVERSMITHS...

860 Broadway, - - - New York.



SPECIALTY: SALES OF JEWELRY, BRIC-À-BRAC AND ARTICLES OF VERTU



## LEGENDS OF GEMS.

By FRANK SHELLEY.

Gilt edged; bound in leather; a perfect specimen of the printer's and binder's art. Should be in every jeweler's library. Price, \$1.00. For sale by

THE JEWELER'S CIRCULAR PUB CO.

## ONE TRIAL

OF OUR WORK ON REFINING OF ALL KINDS WILL CONVINCING YOU THAT OUR RETURNS ARE THE BEST



CONVINCE YOURSELF.  
**GEO. M. BAKER,**  
Gold & Silver Refiner  
and Sweep Smelter,  
PROVIDENCE, R. I.

## Providence.

Clafin & Co. have succeeded Clafin & Hanke, 178 Eddy St., in the manufacture of jewelry.

I. P. Rowe, Marshalltown, Ia., was in town last week calling upon the manufacturers.

George H. Kettlety, formerly of Patt, Kettlety & Kern, has started in the jobbing business at 67 Dabill St.

M. L. Read & Co.'s representative at the Mid-Winter Exposition in California, is daily sending home good orders.

Frank Crandall, of Crandall & Bowers, has been making an extended trip through the Middle States during the past week.

Lockwood & McCloy have abandoned the idea of starting in the manufacturing business at present, owing to the depression of business.

Silas H. Manchester has been appointed an appraiser of the estate of the late Stephen Albro, in place of Walter H. Barney, heretofore appointed.

Henry Wilkinson, of W. S. Hough, Jr. & Co., New York, has been in this city the past few days looking over the manufacturing plant here.

Owing to the serious illness of his wife and the death of his son, George C. McCormick's affairs have not as yet been sufficiently adjusted to make any offer of settlement.

A slight fire in E. L. Logee & Co.'s manufacturing jewelry establishment on Monday evening last, caused a damage of about \$75. It started in a pile of oil waste under one of the lathes.

By the recent assignment of the A. R. Brooks Jewelry Co., St. Louis, Mo., the eastern jewelers are creditors for nearly \$35,000, of which about \$15,000 is held by local manufacturers.

Robert Barton has given a real estate mortgage to Sarah T. Salisbury on property on Brigid and Chapel Sts. for \$9,890.80, subject to two prior mortgages, for \$30,000 and \$5,000 respectively.

Thomas E. Carpenter has mortgaged his real estate on Arch St. to administer of the estate of W. A. Weaver, for \$1,000, subject to a prior mortgage of \$5,500, which has been reduced to \$5,000.

At the annual meeting and election of officers of the Rhode Island Yacht Club, last week, A. E. Austin was elected director, and C. G. Bloomer and A. E. Austin as members of the House Committee.

The H. Ludwig Co. have made the following corporation return to the Legislature: Capital stock paid in December 31, 1893, \$39,500; assets, \$9,209.63; liabilities, \$71,360.44; amount of taxable property, \$8,920.

Wm. H. Draper has sold out his retail business at 256 N. Main St., to Wm. E. Petty and Albert Donahue, who have given a chattel mortgage on the property to Mr. Draper for \$285.14. Mr. Donahue was for several years in the employ of S. Eastman.

The co-partnership heretofore existing between Sterns Hutchins and William G. Hutchins, as S. Hutchins & Co., 21 Eddy St., has dissolved by mutual consent, the latter having purchased the former's interest. The business will be continued by W. O. Hutchins & Co.

Nathan B. Barton and wife left last week for St. Augustine, Fla., where they will join Mr. Barton's partner, E. C. Ostby and wife who have already been there for several weeks. It is the intention of the party to remain in the south for nearly a month, and enjoy the first vacation which either have taken since entering business.

The bowling tournament of the West Side Club, which has been in progress since Jan. 5th, ended the past week, team 2 winning the team record with a total of 19,461. The members of the team are: Henry Fletcher, Robert Spencer, Wm. Otis, John Buffinton and J. M. Boms. Mr. Fletcher takes the first prize in his class, and has the highest record in the tournament.

J. W. Knapp, Cross River, N. Y., has returned from a five months' trip to the west. In his travels he visited the World's Fair, whence he went to South Riverside, Cal. While on the Pacific slope he visited the Mid-Winter Exposition in San Francisco, returning home by way of Mexico, Washington and New York city.

THOMAS W. LIND, Manufacturer of Jewelers' Findings,

67 FRIENDSHIP STREET, PROVIDENCE, R. I.



FULL SIZE NEW, ROCOCO.



Settings Made in Any Desired Thickness of Stock.

Call or send for samples of my New ROCOCO PATTERNS, for Picture Frames, Cane Heads, Whips, Boxes, Napkin Rings, etc.

Large Assortment of TRIMMINGS for Millinery Ornaments, Scarf Pins, etc



**Connecticut.**

The Thomaston watch shop is running full time.

Mr. and Mrs. D. B. Hamilton, left Feb., 27th, on the 10.50 train for Los Angeles, Cal.

The stores of John E. Lomberg, Ansonia, are being extensively altered and improved.

Jeweler Saxton, of New London, turned over his office March 1st to his successor in the collectorship of the port of New London.

E. M. Beckwith, a jeweler of Florence, Mass., is to locate in Torrington, and will occupy a space in the store of J. M. Palmer & Co.

The Meriden Britannia Co. are enlarging and improving their home office to provide additional facilities and room for their office force. An addition 25x10 feet is being erected.

In addition to the \$25,000 sent out by the administrators in checks to legatees of the estate of the late I. C. Lewis, ex-president of the Meriden Britannia Co., \$20,000 more has just been sent out to other legatees, making in all \$45,000 from the estate of the deceased millionaire.

The Silver Plated Ware Manufacturers' Association have just held their annual meeting at the Winthrop Hotel, in Meriden. After the business meeting the guests enjoyed their annual dinner. Delegates from Middletown, Hartford, Wallingford and Meriden were present.

George D. Munson, a popular salesman, residing in Wallingford, employed by R. Wallace & Sons Mfg. Co. for the last 15 years, has just started out on an extended trip in the west. Mr. Munson has just completed a very handsome residence in Wallingford. His father, Captain Munson, has traveled for the same firm many years.

C. A. Hamilton, president of the Rogers & Hamilton Co., Waterbury, and treasurer of the Bridgeport Brass Co., Bridgeport, has been chosen president of the Housatonic Mfg. Co., Wallingford. The company are to increase their business. They formerly were manufacturers of brass and now they are to branch out in the manufacture of German silver goods.

The New York, New Haven & Hartford R. R. Co. have issued an order to the conductors of the road that hereafter they will be required to have their timepieces examined and regulated at specified periods during the year, under the direction of the officials of the road. The order states that the rule will go into effect immediately.

The Meriden Britannia Co. are among the first of the large corporations to take advantage of the expiration of the telephone patents and equip the factory with the instruments. Last week the company began operating the new system, which comprises 24 instruments, all of which are owned by the company, except the transmitters.

The Waterbury Watch Co., Waterbury Clock Co., the Benedict & Burnham Mfg. Co., the Holmes, Booth & Haydens Co., and other large Waterbury manufacturing concerns have in contemplation the enlarge-

ment of their respective plants. The Waterbury Brass Co. have occupied for the first time within a week their new brick and iron rolling mill, and not long ago opened a new wire mill.

Louis Hahn, the New London jeweler, has been prominently identified with the interests of the Chesterfield Colony of Russian Hebrews since its establishment. Mr. Hahn is considering a proposition from the trustees of the fund which was established by Baron Hirsch to identify himself with them and aid in establishing new colonies. In case of his acceptance Mr. Hahn would take up his residence in New York.

In certain departments the manufacturing concern of the R. Wallace & Sons Mfg. Co. are taxed to their utmost capacity. Their silversmiths and general silver workers are very busy and orders have been received very rapidly recently. Since Jan. 1st the firm have purchased more silver than ever before, and it is being rapidly converted into goods. Wallace & Sons expect to occupy their fine new store, 226 Fifth Ave., New York, by June 1st. The finishing touches are now being done. It is a five-

story building, 22x103 feet, and is right among the fashionable retail trade that the house are catering to.

**Still Another Silverware Manufactory for Wallingford.**

WALLINGFORD, Conn., March 2.—There is a lively prospect that yet another silver goods manufactory will be established here. A number of capitalists, some of them Bostonians, propose to organize a company with a capital of \$12,000 for a starter, and erect a brick manufactory on the Wallingford Plains for the manufacture of silver plated ware. Noah Linsley and E. C. Valentine, who are now doing a small business on S. Main St. here, are interested in the project.

The stock is already all subscribed for and the proposed company only ask of the town for the same temporary immunity from taxation that has just been granted the Biggins company, viz: exemption from town and borough taxes for ten years, and water rentals for five years. A meeting of citizens was held in Hon. Samuel Simpson's block last evening to discuss the matter.

# CHARMILLES

(PRONOUNCED SHAR-MEAL.)

is the name of a new **HIGH GRADE, LOW PRICE WATCH** constructed on an entirely new and novel plan and which is now being put on the market through the jobbing trade, and will be extensively advertised to the trade and general public.

**IT IS SURE TO BE A WINNER,**

as it possesses greater merit than any watch made for the money.

**ASK YOUR JOBBER FOR THEM . . .**

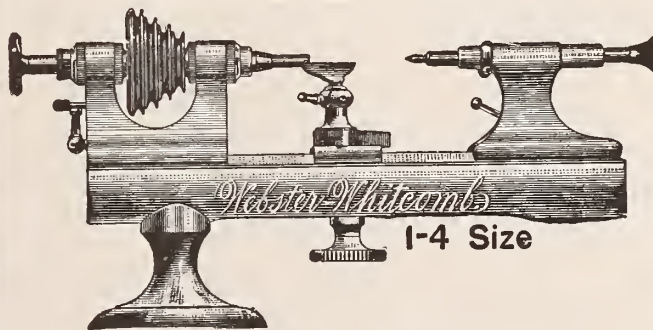

**STRONGEST GUARANTEES.**

**Quality Maintained. Prices to Suit the Times.**

Ask for our New Prices and Terms for 1894.

## American Watch Tool Company,

Chymistry Dist., Waltham, Mass., Stoney Batter Works.



THE STAR OF EMPIRE WESTWARD TAKES ITS WAY!

# WESTERN SUPPLEMENT of THE JEWELERS' CIRCULAR

**Chicago Office: Room 308, Inter-Ocean Building.**

VOL. XXVIII.

CHICAGO, WEDNESDAY, MARCH 7, 1894.

No. 5

### Chicago Notes.

Manager Prentiss, of the Gorham Mfg. Co., returned Monday week from his visit east.

Warner Silver Mfg. Co., of Chicago, have incorporated with a capital stock of \$25,000; incorporators, Augustus Warner, P. B. Warner, Cassius C. Palmer.

George B. Elbe has been endorsed for alderman from the 9th ward. Mr. Elbe is a young business man engaged in the jewelry business at 573 Blue Island Ave.

The continued stormy weather has deterred buyers coming from a distance and it is noted that a large majority of the trade now buying are from Illinois. Sunshine and dissolved drifts are needed.

One of the popular young men of the West Side is Herbert W. Duncanson, the well-known Madison St. jeweler, who is prominently mentioned and widely indorsed as the candidate for the Republican nomination in the 12th ward aldermanic race this Spring.

A steam roll of latest construction, a fine piece of work from the Chicago Watch Tool Co.'s factory, has been added to the factory of B. Grieshaber. Mr. Grieshaber believes in nothing but the best machinery, and his shop is equipped throughout with the best machinery for gold pen manufacture.

S. Nathan and wife celebrated the silver anniversary of their wedding at their home, 3914 Prairie Ave., Wednesday. Among those present from the trade were noted M. C. Eppenstein and wife, Michael Cohn, William Manheimer and Manager Duncan, of the Illinois Watch Case Co., Elgin, Ill.

Mr. Stein, of Stein & Ellbogen Co., who returned the 21st ult., shows up in rugged health. While abroad Mr. Stein spent most of his time at Wiesbaden, Germany, and found the special treatment for the eyes there given to be greatly beneficial. His general health also was much improved. Mr. Stein has again taken up an active interest in the company.

William H. Smith, in charge of the repair department of Rowe Bros., returned the past

week from the sad duty of attending his father's funeral, at Wooster, O. W. H. Smith, Sr., was 81 years of age, and died suddenly, Feb. 22d, from paralysis. He leaves three sons in the jewelry business: Walter G. Smith, Youngstown, O.; Frank K. Smith, with Louis Bros., Piqua, O., and W. H. Smith, with Rowe Bros., Chicago.

Silversmiths and retail jewelers are showing a number of Easter goods that are very pretty. Noticeable among them are exquisite prayer book markers consisting of three narrow satin ribbons joined at one end to a silver star, the loose ends being tipped with a sterling silver cross, an anchor and a heart. The ribbons are in either white or purple, and the marker is neat and attractive.

The following report was made by H. M. Carle, treasurer of the jewelers' branch of the Central Relief Association, under date of March 1st, and shows what thorough organization can accomplish in charitable affairs:

Total amount collected.....	\$8,160 58
Paid to treasurer C. R. A.....	7,190 00

The expenses have been but a trifle and several hundred dollars are now in the local treasury. It is pleasant to note that the jewelers responded more liberally than any other trade organization to the call for money for charitable needs.

W. H. Walmsley the past week opened up in business at 63, 65 Washington St., suites E and F, third floor, under the old Philadelphia firm name of W. H. Walmsley & Co., with an aim to cater to the most exacting needs of microscopists and photographers, both professional and amateur. A leading specialty with the house will be the Ross lenses for which Mr. Walmsley has been appointed sole agent in this city. As a past student in microscopical research, photo-micrography and photographic processes, Mr. Walmsley is widely known. An intimate acquaintance with heads of institutions of learning and members of scientific societies coupled with a knowledge of the lines carried assures the firm's success.

The efficient manager of the Masonic Temple building, William F. Grower, is very much awake these days, as shown by the number of jewelers who have recently decided in favor of the Temple as a business location. THE CIRCULAR previously announced the leasing of 2,000 square feet of the fourth floor to A. Hirsch & Co. Since then the entire floor has been leased as follows, taking the State St. frontages in their order from Randolph St. north: A. Hirsch & Co., W. S. & J. B. Wilkinson, Katlinsky & Gatzert, Metzberg & Co., and S. Buchsbaum & Co. Hirsch & Co. expect to move into their new quarters the present week, the carpentry work on the salesroom and private and business offices being nearly completed. The rooms are well lighted and finely arranged for the conduction of a large jobbing business. Katlinsky & Gatzert moved into their new quarters Thursday. The Wilkinsons, Metzberg and Buchsbaum will have their quarters ready the present week.

The following firms were last week represented by buyers in the Chicago trade: W. P. Yeoman, Waukegan, Ill.; R. E. Winter, Fort Meridan, Ill.; G. O. Warren, Sycamore, Ill.; Whorley & Hester, Anchor, Ill.; J. W. Spence, Racine, Wis.; W. E. Southard, Prophetstown, Ill.; H. E. Shell, Ohio, Ill.; Mrs. F. J. Reemer, So. Chicago, Ill.; P. Pfeiffer, Lamont, Ill.; L. W. Morey, Slayton, Minn.; F. W. Moore, Maywood, Ill.; Albert Miller, Dundee, Ill.; L. Luchtemeyer, Blue Island, Ill.; M. Headman, Table Grove, Ill.; R. E. Fidler, Saybrook, Ill.; L. N. Tenne, Wanconda, Ill.; W. W. Denny, Aurora, Ill.; J. F. Ingalls, Waukegan, Ill.; J. W. Burkett, Arlington Heights, Ill.; C. S. Dustin, Stillman Valley, Ill.; O. S. Clayton & Son, Aurora, Ill.; E. D. Conant, Hudson, Mich.; Geo. F. Beach, Valparaiso, Ind.; C. E. Barnum, Onarga, Ill.; L. H. Bauer, Elgin, Ill.; G. W. Hay, Attica, Ind.; W. A. Johnson & Bro., Tuscola, Ill.; W. J. Keating, Watertown, S. D.; Lathrop & Co., Fort Wayne Ind.; Geo. Benz, St. Paul, Minn.

N. B. Shire & Co., Nashville, Tenn., propose to go out of business next Fall.



**Last Honors to the Memory of Sebastian Andersen.**

CHICAGO, Ill., March 3.—In the death of Sebastian Andersen, which occurred suddenly Feb. 25 from apoplexy, as stated in THE CIRCULAR of last week, Chicago loses a most esteemed citizen. Mr. Andersen was born at Tondern, a small town in Schleswig-Holstein, Germany, Aug. 2, 1828, and at an early age learned the trade of manufacturing jeweler in the establishment of Johannis Hanson, of that town. Later he went to Hamburg, and when the war between Schleswig-Holstein and Denmark began he took up arms in favor of his native country and served from 1849 to 1851, engaging in five battles. At the close of the war he returned to Hamburg for one year and then came to America, landing at New York, Oct. 28, 1852.

Here he entered the employ of John Myers, 11 Spruce St., as silversmith. Three years later he engaged in business as Andersen & Boltzows. This partnership continued until Jan. 1, 1857, when it was dissolved and Mr. Andersen linked his fortunes with those of Paul Juergens, who had established a business here in 1854, at 77 Lake St. The partners were brothers-in-law, Mr. Andersen having married Mr. Juergens' sister. A year ago the firm incorporated as the Juergens & Andersen Co., and Mr. Andersen was elected president.

Mr. Andersen leaves a widow and two sons and a daughter. Julius P. Andersen is a stock raiser in Texas; William G. Andersen is a stockholder and takes an



THE LATE SEBASTIAN ANDERSEN.

active interest in the Juergens & Andersen Co. The funeral was held Wednesday and was largely attended by the business asso-

ciates of the deceased, the members of the Chicago Jewelers' Association attending in a body. Services at the house were conducted by Dr. Zimmerman and the Rev. Mr. Koerner in German and English, and the remains were interred at Graceland.

Beneath a rugged exterior beat a heart in warm sympathy with his fellow-men; a lofty character best known to those who know him best. His many qualities of heart and hand were not worn upon his sleeve to be viewed by the curious. He had a heart and soul of true worth, beneath a rougher outer covering.

**Bids for the Assets of Giles, Bro. & Co.**

CHICAGO, Ill., March 3.—At the Giles, Bro. & Co. hearing before the United States Circuit Court, Feb. 26, to take action on bids for the assets of the insolvent bids as high as \$23,000 were opened and the time extended for closing bids extended to March 10.

The following is the estimated value of assets:

Stock as scheduled.....	\$70,943 41
Material .....	750 00
Fixtures .....	1,000 00
Accounts and bills receivable.....	4,874 92
Equity in real estate.....	500 00

Total.....\$78,068 33

Each bid must be accompanied by a certified check, draft or certificate of deposit, payable to the order of the receiver, for at least 5 per cent. of the amount bid.

**TWO OF A KIND!!**



Two of a kind is a good hand to draw to, especially if they're a big two, like Messrs. Joy and Happy above. These two win others to their standard.

JEWELER JOY—Where do you send your sweeps and old gold and silver, Happy?

JEWELER HAPPY—The last went to Goldsmith Bros.

JOY—Where'll you send the next?

HAPPY—Straight to the Goldsmith boys. Their tests are accurate and their valuations correct, and besides they remit by cash or draft on receipt of shipment, and if offer is not satisfactory will send back the stuff and pay all charges.

JOY—I know! I know! I have sent to them for years. And they've got a very useful Vest Pocket Edition, giving pointers on testing and buying gold, that they mail to jewelers free.

When two Jewelers meet who have sent sweeps or old gold and silver to us, there can be no two differing opinions—they are TWO OF A KIND.

**GOLDSMITH BROS.,**  
**GOLD, SILVER AND PLATINUM REFINERS,**  
 63 and 65 WASHINGTON ST., CHICAGO, ILL.



# "Best" Eye Glasses.



The "BEST" Guard embodies some new features of great value. The lower part is rigid, the upper part is flexible. Made in both shell and cork. Must be seen to be appreciated.

Sample Eyeglass Frame, in 10k. gold, - -	\$2.90
" " " " in Steel or Nickel, -	.35
Sample Pair of 10k. Gold Guards, -	.85
" " of Nickel Guards, -	.15

**Geneva Optical Company,**  
69 WASHINGTON STREET,  
CHICAGO.

## CHAS. H. PFEIL, MANUFACTURING JEWELER. Diamond Work a Specialty.

**BEST of Workmen.  
BEST Design Work.  
GUARANTEED Workmanship.**

Send a trial order and be convinced.  
**182 State St., Chicago.**

**HUGO MUELLER,**  
182 State St., (Room 70,) Chicago.  
**FINE WATCH REPAIRING**  
IN ALL ITS BRANCHES.

Work for the trade promptly executed by skilled workmen.

**PARSONS : SCHOOL**  
—FOR—  
**WATCHMAKERS,**  
PEORIA, - - - ILL.

Send for Circular and Terms.

**PARSONS & CO.**

WATCH CASE MAKERS AND REPAIRERS.  
**BOLSTAD MANUFACTURING**  
**AND PLATING CO.,**  
GOLD AND SILVER PLATERS.  
DESIGNING AND ENGRAVING.  
170 Madison Street, - - CHICAGO.

**ELGIN HOROLOGICAL SCHOOL,**  
THOROUGHLY PRACTICAL.  
COMPETENT INSTRUCTORS.  
Send for Prospectus.  
**ELGIN, ILL.**

### Detroit.

Edward Roehm has recovered from an attack of the grip.

News was received here last week of the death of Mrs. O. D. Chapman, wife of a leading jeweler of Coldwater.

R. J. F. Roehm & Son designed the past master's jewel, recently presented to Chas. D. Hastings, by Palestine Lodge, F. & A. M. Chas. Rowe, who was a stockholder in the firm of F. G. Smith, Sons & Co., has severed his connection with the company.

O. A. Schneider, with Hammel, Riglander & Co., visited the trade here last week. He was the guest of John Drexel, watchmaker.

Eugene Deimel was busy last week, re-decorating and improving his store which was recently damaged by smoke and water from an adjacent fire.

The gavel used by Thomas W. Palmer, of

Detroit, to mark the close of the World's Fair, is on exhibition in the windows of F. G. Smith, Sons & Co.

Word was received here last week that the firm of Hendrickson & Leinard, jewelers, Paulding, O., had been dissolved. Mr. Leinard will continue the business.

Charles Raymond, for many years with F. G. Smith, Sons & Co., has left the firm, to become "special" in this city for the Fidelity & Casualty Co., of New York.

James Kaywood runs a traveling jewelry car. Last week a gang of hoodlums attacked his car during the night at Leoni, Mich., and destroyed goods of considerable value.

John Neiper, formerly a Gratiot Ave. jeweler, left his business three years ago to go into the internal revenue office here. A change of administration threw him out of employment last week. He will probably resume his former vocation.

## PATENT FIBRE-FACED HAMMERS.

5 oz. for Watchmakers.  
10 oz. for Manufacturing Jewelers.  
Price 50 Cents Each.

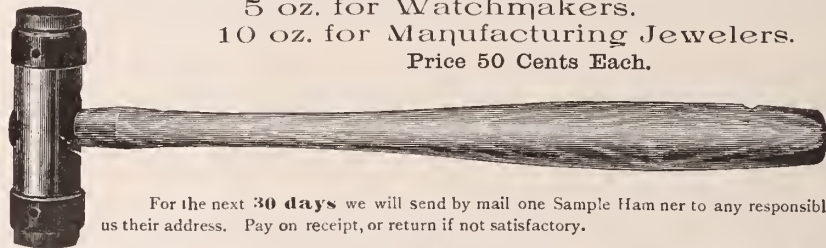

For the next 30 days we will send by mail one Sample Hammer to any responsible firm giving us their address. Pay on receipt, or return if not satisfactory.

**W. W. OLIVER, Sole Manufacturer, - Buffalo, N. Y.**

Send for our No. 10 Catalogue.



## GIBSON HOUSE,

CINCINNATI, OHIO.

ABSOLUTELY FIRST-CLASS AMERICAN PLAN HOTEL.

\$3.00 PER DAY.

Extra Charge for Parlors and Rooms with Bath attached. The unequalled advantages in central location, liberal management, modern appointments, experienced service and perfect cuisine, have permanently established the Gibson House as The Most Popular First-Class Hotel in Cincinnati.

AMPLE VAULTS FOR THE PROTECTION OF VALUABLES.

**THE GIBSON HOUSE CO.,**

H. B. DUNBAR

President and Manager

EST. 1870. **DR. PETER HENRY,**  
SPECIALIST IN  
**WATCH • CASE • DISEASES**

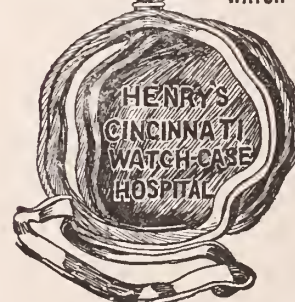

Key Winders changed to Stem Winders.

Hunting Case changed to O. F.

English Cases changed to fit American movements

Can be cured at 53

Longworth St., Cincinnati, Ohio.

**R. M. JOHNSON,**

IMPORTER OF

**Diamonds AND Manufacturing Jeweler,**

67 WASHINGTON STREET,  
ROOMS 5 & 6,  
CHICAGO.

MASONIC EMBLEMS OF EVERY DESCRIPTION MADE TO ORDER.



One of the best of the very best.

QUALITY IS THE STANDARD OF VALUE.

CHARGES TO SUIT THE TIMES.

When interested, write your jobber for new price list for 1894, or

**Moseley & Co., Elgin, Ill.**



No. 2 Moseley Wire Chuck has length, strength, accuracy.



A few Michigan country jewelers put in an appearance here among whom were: S. A. Cleveland, Utica; F. J. Barlow, Williams-ton; J. S. McGlaucklan, Wyandotte; Geo. Chambers, Mt. Clemens, and C. E. Mont-ford, Utica.

**Pacific Coast Notes.**

Burglars entered the store of C. F. Adams Co., San Francisco, some nights ago and carried off about \$400 worth of silverware.

Arthur J. Eaton, San Francisco, who was injured by a fall as recorded in THE CIRCULAR last week, is in a serious condition, his injuries consisting of a fracture of the skull.

H. H. Fisher, employed with Jackson & Earle, Stockton, Cal., is at work on a device by which the dials of clocks can be illuminated so as to tell the time in the dark.

J. A. Simms, who bid in the Stanton stock in Riverside, Cal., will not undertake to do anything with it until the litigation between the sheriff and H. L. Rothschild, now pending, is over.

The courts have ruled in the cases of arrests for having chained chameleons on sale for use as ornaments, that the wearers of the living pins and not the dealers are liable to punishment for cruelty to animals.

On the evening of Feb. 21st, about 7.30 o'clock, J. Hyman, Jr., jeweler, on J St., Sacramento, Cal., while sitting near the show window, heard a crash of glass and saw a hand thrust through the broken window and grab two gold watches and several diamond rings and earrings. He gave the alarm, but the thief ran away and escaped.

No warrant has been served upon Mrs. Wm. Faessler, the wife of the Oakland jeweler, who under the influence of her father, has sworn to kill her husband unless he rights some fictitious wrongs. When the charge of insanity against her was dismissed, she agreed to keep the peace for the rest of the week, but no longer. In the meantime her husband was to cause the arrest of his wife and father-in-law and have them held in bonds to maintain the peace. So far this has not been done.

**Cincinnati.**

Harry Walton, of the Wadsworth Watch Case Co., is in the east looking up trade.

Homan & Co. have issued four times the amount of goods they ever did at this season. Their new specialties are creating a large demand for themselves.

A. G. Schwab & Bro. have secured the services of F. L. Davies, formerly of Nashville, Tenn., to represent them on the road.

Jos. Noterman & Co. report that order work is reviving. More orders for diamond resetting are being received this year than ever before.

Lee Strauss, of the old firm of Strauss & Stern, has temporary quarters with Thos. Lovell, the 5th St. jeweler. He expects to open a jobbing house in the Fall.

The Cincinnati retail jewelers have organized and will hereafter hold monthly meetings. The officers of the body are as follows: President, J. J. Wurre; vice-

president, J. H. Lentz; secretary, Lewis Hohneck; treasurer, Jos. Daller; board of directors: M. C. Motch, Jas. Sauer and Louis Hummel.

**Rockford, Ill.**

John Hamilton, who recently severed his connection with the Rockford Watch Co., is now on the road for the Dueber Watch Case Mfg. Co.

The boilers are set in the factory of the National Cutlery Co., the new engine is on place, and the first instalment of the special machinery for the grinding and polishing is complete. Secretary Kelley is much pleased with the last tools, as they were a special design, built to the Rockford order, and unlike anything before made. The rights are held here. What remains to make the plant ready for full operation is being hurried along.

**REED & BARTON,**

**SILVERSMITHS,**

MANUFACTURERS OF

STERLING *and* SILVER PLATED  
SILVER WARE.

SALESROOMS:

**37 Union Square, New York.**

34-36 WASHINGTON STREET,

**Venetian Building, Chicago.**

FACTORIES, TAUNTON, MASS.

**LOOK OUT** 

For our new illustrated Tool and Material Catalogue of 464 pages. It is the largest and most complete catalogue ever issued. We have made many substantial reductions in prices, and can meet the wants of every Jeweler desiring the best goods at lowest possible prices.

\*\*\* WATCH FOR IT ABOUT MARCH 15TH. \*\*\*

Should you fail to receive a copy, notify us and we will be pleased to send you one.

**BENJ. ALLEN & CO.,**

WATCHES, DIAMONDS AND JEWELRY,

141 AND 143 STATE STREET,

CHICAGO, ILL.



**Minneapolis and St. Paul.**

George F. Gage watchmaker for Eustis Bros., Minneapolis, for a number of years, has resigned his position and gone to Portland, Me., to reside.

The Pairpoint Mfg. Co. have entered a petition to sue George R. Robinson, assignee, of B. B. Marshall & Son, Minneapolis, on replevin, for \$31.16 worth of merchandise.

Krementz & Co., New York, have brought suit against Harry F. Legg, Minneapolis, to recover \$959.93 due for merchandise. Carter, Sloan & Co., New York, also sue to recover \$1,129.47.

J. E. Reid, formerly with E. A. Brown, St. Paul and R. G. Winter, Minneapolis, has bought out the business of A. Wester-

baum, Rochester, Minn., and will continue the same.

O. A. Kvam, for the past 10 years watchmaker for W. C. Leber, Minneapolis, died on Feb. 25th, at St. Mary's Hospital, that city, from the result of a surgical operation. The deceased was 40 years of age.

Samuel Sargent, St. Paul, was arrested on Feb. 25th, on a warrant charging him with receiving stolen property. The warrant sworn out by the Reed & de Mars Jewelry Mfg. Co., Minneapolis, alleges that Sargent received \$330 worth of gold rings and chains from W. E. Roundy, who since has been convicted and sentenced to State's prison. When tried in the Municipal Court Feb. 27th, the prisoner was dismissed, the State being unable to make a case against him, by reason of several witnesses suddenly departing from the city for parts unknown.

E. W. Storer, one of Minneapolis' pioneer watchmakers, who three years ago retired from the jewelry business and since traveled throughout the western mining country prospecting, has returned to this city and opened up a place of business at 405 Hennepin Ave.

P. D. Boutelle, assignee of the Donelson Jewelry Co., Minneapolis, is at work trying to close up the estate and effect a settlement with the creditors, who, although they have been served with notices to file claims in order to share dividends, are rather slow in responding. The company contemplate re-suming business.

E. E. Spaulding, until recently traveling salesman for Lapp & Flershem, Chicago, has gone into partnership with his brother, F. W. Spaulding, Minneapolis, the new firm name being Spaulding Bros. He will represent the firm on the road, and will carry a complete line of tools, materials and jewelers' supplies.

**Indianapolis.**

C. W. Delaney, Hammond, Ind., has moved into a handsome new room in the Masonic Block.

Jasper C. Whistler, Marion, Ind., will shortly open a new jewelry store next to L. M. Whistler & Son.

Spring trade is growing slowly. In Jan-

**Engravers' Type.**

A Rubber Type in new styles specially adapted to Engravers' use. Seven different sizes now ready.

*Minnie S. Foster*  
*Sir Walter Scott.*

Does away with all tracing.  
Letters are stamped upon the article in clear cut script or old English.  
The outline can readily be engraved by even the apprentice.  
Type made on new principle, bevel edged; alignment guaranteed.  
Every Engraver should have it.  
Write for particulars.

**WM. H. DIETZ,**  
117 Dearborn Street, Chicago.



The only Genuine Chuck is the TRUE One.  
The only Chuck made invariably true is the Dale.

**BUY THE ONLY GENUINE CHUCK,  
THE DALE, \$1.00.**

... THE ...

**American Horological Institute**

AND TECHNICAL SCHOOL OF LANCASTER, PA.,  
LATE OF PHILADELPHIA, PA.,

A Trade School where Watchmaking is taught practically. We do not manufacture

❁ BICYCLES OR DYNAMOS ❁

at this institute. We confine our work strictly to WATCH WORK and its kindred branches, which include

== Engraving, Jewelry Work and Optics ==

One tuition pays for all the branches. We do not have boy instructors at this institute, all men of years of experience. Each department has its separate instructor. Our institute is open for inspection. We kindly invite you to visit us and inspect our school modes of giving instruction and the progress that our students make by giving them practical instruction.

**THOMAS PENDERGAST,**  
PROPRIETOR AND MANAGER.

**DUEBER-HAMPDEN WATCHES.**

The most reliable watches are the Hampden 17 Jewel. A full line of Dueber Cases and Hampden Movements. Cash buyers write us.

**BRETHAUER WATCH & JEWELRY COMPANY,**

SPECIAL AGENTS,

71 WASHINGTON ST., CHICAGO, ILLS.

**THE PLANCHAMP & BECKER CO.**

Makers and Repairers of

**WATCH CASES,**

Gold and Silver Plating —

— of Watch Cases a Specialty.

UNEXCELLED FACILITIES.

63 and 65 East Washington St., Chicago.

WHEN IN CHICAGO, VISIT THE

**Chicago Watchmakers' Institute,**

SUITE, 1521-1523 B MASONIC TEMPLE.

A Modern Trade School for the Watchmaker, Jeweler and Engraver.

Write for New Catalogue.





uary the volume of business fell off one-third. February showed sufficient increase to encourage both jobber and retailer.

**Kansas City.**

Frank B. Altman has been chosen as one of the members for the grand jury for the April term of the criminal court.

Henry Rummel, the aged father of jeweler Julius Rummel, died recently at Independence, Mo.

Dale & Chapman's jewelry store, Bennington, Kan., was last week broken into by burglars, who stole a lot of jewelry and watches.

The Johnston Optical Co., Detroit, Mich., last week filed suit against jeweler T. J. Turner for \$78.94, on account. Mr. Turner failed more than a year ago.

Two burglars were detected in the act of breaking into Louis Hoffmann's jewelry store, at Leavenworth, Kan., a few nights ago, by special policeman Titel. He tried to capture them and was knocked unconscious and severely injured. The men escaped, leaving behind some excellent "jimmies."

**Delay in the Performance of an Operation Proved Fatal to Jeweler Kvam.**

MINNEAPOLIS, Minn., March 2.—O. A. Kvam, a well known jeweler, died at St. Mary's Hospital on Sunday, the cause of death being due to collapse resulting from an operation which was performed on him Saturday. Kvam had been suffering from an ulcer in his stomach and called upon Dr. Knut Hoegh for treatment. The latter, after diagnosing the case, advised an immediate operation. This was over two weeks ago, but the patient did not care to submit himself to an operation. He grew worse, and Saturday called again on the physician, being then in a very weakened condition.

The operation was performed and was a success, the ulcer being found at the exact spot denoted by Dr. Hoegh. The patient was very weak, but grew stronger, and the

surgeons were hopeful that he would soon recover. Sunday, however, he suddenly collapsed and passed away. Dr. Hoegh said the operation is not looked upon as at all dangerous, and had Mr. Kvam consented to have it done two weeks ago he would now have been a well man.

**The Peace of the City of Churches Disturbed by Window Smashers.**

BROOKLYN, N. Y., March 3.—The Brooklyn police are looking for two men who committed a daring burglary on the evening of Feb. 26th at the jewelry store of Mendel Lazarus, 1864½ Fulton St.

Mr. Lazarus was behind his counter, placing some jewelry in a tray, when his attention was attracted to two young men who acted as if about to enter the store. They seemed to change their minds, however, and began looking at the display of watches and jewelry in the show window. Suddenly one of the men broke the glass in the show window and grabbed a tray, on which were 19 gold and silver watches, in all valued at \$250. Both men then ran down Fulton St.

Jeweler Lazarus rushed from behind his counter, arming himself with a revolver as he did so, and attempted to open the front door, but it could not be opened. He then ran through to the rear of the store, but the men who had robbed him were, however, out of sight by this time. On the sidewalk the jeweler picked up four of the watches. Mr. Lazarus found that a heavy steel chisel had been placed in such a position between the knobs of the door as to prevent the door from being opened from the inside.

The Boston Novelty Co., Cleveland, O., have incorporated with a stock of \$50,000, for the purpose of "purchasing and selling at wholesale and retail, jewelry, musical instruments, books, crockery, household furniture, etc." The promoters are: E. E. Dellenhaugh, Jno. F. McCarthy, H. B. Hayden, Leonard Hershey and Irving Hershey.

**Points of Law.**

**POWER OF PARTNER TO BIND FIRM.**

A partner in a mercantile firm cannot bind the firm by subscribing to the capital stock of a corporation, for the establishment of a mill, without the consent and ratification of the other member of the firm.

*Patty v. Hillsboro Roller-mill Co., Court of Civil Appeals of Texas.*

**LIABILITY OF TELEGRAPH COMPANY FOR DELAY IN TRANSMITTING MESSAGE.**

The acceptance of a dispatch by a telegraph company from a connecting line in the usual course of business for transmission over its own line creates an implied contract with the addressee to exercise reasonable diligence in transmitting the message to its destination and delivering it to the addressee, and it is liable to him for negligence in failing to do so.

*W. U. Tel. Co. v. Lyman. Court of Civil Appeals of Texas, 22 S. W.*

**SETTING ASIDE ASSIGNMENT FOR OMISSIONS IN SCHEDULES.**

Omissions from and inaccuracies in the schedule of assets and schedule of creditors, which the law requires to be attached to a voluntary assignment for the benefit of creditors by an insolvent debtor, may or may not be sufficient to invalidate the assignment. It is impracticable to lay down any rule as to what may be omitted from these schedules. In each particular case the question should be determined with reference to the number, materiality and importance of the omissions, and whether they were made by oversight and inadvertence, or deliberately, with intent to defraud. In applications for injunction and receiver, the determination of this question is addressed to the sound discretion of the presiding judge. Intention to defraud in any material matter whatever, will always vitiate the assignment.

*Wood v. Hayes, Supreme Court of Georgia.*

**A SWINDLE!**

The Watchmakers, Jewelers and Opticians throughout the United States and Canadas are cautioned to

**BEWARE**

of Cheap Carved Iron Watch and Spec. Signs, made in imitation of ours by UNSCRUPULOUS PARTIES in Chicago and New York, claiming to be "SUPERIOR" Metal Signs. They are cheap, hollow and brittle things, made of poor THIN ZINC. While they are a little cheaper in price than ours, they are fully 75 per cent. below in Style, Finish and Durability, and are PRACTICALLY WORTHLESS

ALL of the GENUINE Carved Iron Watch Signs have "GROUT'S EXCELSIOR SIGNS," in SMALL BLACK LETTERS, close UNDER the HANDS on the DIALS, as shown in our illustrations, and also look for letter "G" on end of Spec. Signs. ANY OTHERS ARE FRAUDS.

**LOOK OUT FOR THEM**

AS WE WANT ALL WHO BUY IRON WATCH SIGNS PROTECTED,

Made only by the **EXCELSIOR SIGN & MFG. CO., CHICAGO.**

SEND FOR OUR ILLUSTRATED 64-PAGE CATALOGUE OF SIGNS & TOOLS, FREE.



**DIAMONDS.****Wm. S. Hedges & Co.,****Importers of Diamonds,**

And Manufacturers of DIAMOND JEWELRY.

**170 Broadway, New York.**

22 Holborn Viaduct, London.

**R. A. KIPLING,**

Importer of

**PRECIOUS STONES,****21 & 23 Maiden Lane,****19, RUE DROUOT,  
PARIS.****New York.****CALIFORNIA  
MIDWINTER FAIR.****Novelties** IN  
**Sterling and Plated  
Souvenir Spoons, Silver  
Plated Trays, Match Boxes,  
Paperweights, Charms, Sleeve  
Buttons, Rings, etc., etc.****Julius Eichenberg,****174 Weybosset Street,  
Providence, R. I.****CROUCH & FITZGERALD,**Jewelry Trunks  
and Cases

161

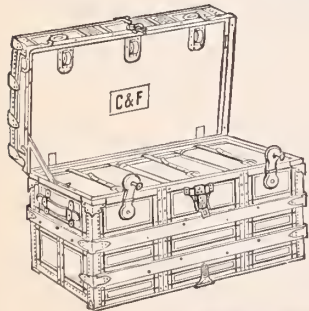
**Broadway,**Bet. Cortlandt and  
Liberty Sts.,**688 B'way,****101 6th Ave.,****NEW YORK.****Alfred H. Smith & Co.,****IMPORTERS****DIAMONDS**

AND

**PRECIOUS STONES,****182 BROADWAY, COR. JOHN STREET,****NEW YORK.****33 Holborn Viaduct, London, E. C.****HENRY FERA,**  
IMPORTER OF DIAMONDS

AND DIAMOND BORTZ.

Diamond Cutting and Polishing Establishment.  
**10 Maiden Lane, NEW YORK.****PATENTS** SECURED WITHOUT  
FAIL OR DELAY.Send Rough Sketch or Model and I will tell you  
whether you can obtain a patent,  
WITHOUT CHARGE.  
Fifteen years' experience. Ample references. Address**C. T. BELT,**  
WARDER BUILDING, WASHINGTON D. C.**HENRY ABBOTT,**

MANUFACTURER OF

**Stem-Winding Attachments****FOR WATCHES,****No. 2 Maiden Lane, NEW YORK.****Fashions in Jewelry and Silver-  
ware.**

A LADY'S RAMBLES AMONG THE JEWELERS.

Platinum is holding its own.

There are new designs in toast and muffin racks.

Silver soap baskets for the bath tub are produced.

Italian and French Renaissance forms prevail in table silver.

The newest silver bracelet is a heavy double twisted chain. It hangs loose and is fastened with a silver padlock.

The number of small alcohol lamps now in the market seems to show that cigar and cigarette smoking is on the increase.

A striking brooch was noticed. It was a square topaz set around with pearls and surrounded by gilt spikes, the end of each piercing a pearl.

Silver hat pins are in pretty new shapes. One of these may be described. It is as filmy as a soap bubble and powdered with solid bits highly polished.

There will be a great demand for buckles this season. They are to be used on almost everything. There is a fancy in millinery for oblong curving buckles.

The newest standard for a Farina cologne bottle has spike-like forms resembling a beard of wheat which, attached to a round cup like base, hold the bottle.

A safety hat pin is accompanied by a plate that is attached to the under side of the hat. The hat has a dent that fixes in a groove in the slot of the plate.

The sentiment connected with the heart still flourishes. There are numerous styles in little flat heart shaped novelties. These have stones sunk in them, or encrusted with bits of enamel, or are plain.

Tubular vases of silver are brought out in various forms. The prettiest are like twisted horns. Standards with these are arranged for individual flowers. Single horns keep their identity or lose it in waving lips suggestive of the deep cup of the Virginia creeper and the morning glory.

Back combs of silver are evidently going to take a prominent place in the Summer toilette. They borrow the designs of the gilt combs, but have a taking way of catching and throwing off the light which makes them almost as sparkling as jeweled combs. They are mounted on shell teeth, and on silver teeth. These are twisted for safe keeping.

ELSIE BEE.

J. C. Plaut, Cincinnati, O., has invented a leather and wire sleeping car, ladder and has been trying to induce the Pullman Palace Car Co. to adopt it. Being unsuccessful in this he is now interesting himself in the enactment of the Strehle bill, which includes a clause to the effect that there shall be a ladder for each upper berth.

**ONE FEATURE**

OF

**THE JEWELERS' CIRCULAR.**

ONE OF MANY,

Think each article you  
publish about "Window  
Decoration" worth the full  
price of your subscription.

GEO. E. FEAGANS,

JOLIET, ILL.

SEE PAGE 28.



**Queries by Circular Readers.**

*Editor of THE JEWELERS' CIRCULAR:*

Please give names of a few good parties who can manufacture a patent chuck for watchmakers' lathes.  
E. J. FAUST.

ANSWER:—American Watch Tool Co., Waltham, Mass.; Moseley & Co., Elgin, Ill.; Hardinge Bros., Chicago; Waltham Watch Tool Co., Springfield, Mass.

*Editor of THE JEWELERS' CIRCULAR:*

What is the best work published on the construction and use of the ophthalmometer of Javal and Schiötz?  
H. C. REES.

ANSWER:—Georgen & Hahn, manufacturers of the Javal and Schiötz ophthalmometer, recommend the work of Dr. Francis Valk, entitled "Errors of Refraction," published by G. P. Putnam's Sons, New York. THE CIRCULAR has the book on sale.

*Editor of THE JEWELERS' CIRCULAR:*

Will you kindly inform us where we can obtain copy of Hall marks, showing the different letters which signify the year in which goods were made.

HANSEL, SLOAN & CO.

ANSWER:—Your letter is indefinite, as almost every country and town of Europe have their own Hall marks. If you refer to London Hall marks, perhaps no work is more complete and accurate than J. H. Buck's "Old Plate," published by the Gorham Mfg. Co.

*Editor of THE JEWELERS' CIRCULAR:*

I wish you would kindly furnish me with the addresses of the best picture frame and fine art wholesale dealers in your city, both picture dealers and frame dealers, as I intend opening an art department in my store.  
T. C. TANKE.

ANSWER:—Picture dealers: Fishel, Adler & Co., 94 Fulton St.; M. Knoedler & Co., 170 Fifth Ave.; Wm. Pate & Co., 146 William St., and Currier & Ives, 115 Nassau St., New York. Manufacturers of frames: Spiegel & Son, 155 Chambers St.; G. Wuerth Mfg. Co., 46 Marion St., New York. Of course there are many others, but the foregoing is a fair selection of the trades.

*Editor of THE JEWELERS' CIRCULAR:*

Will you please tell me the reason why I cannot get a good Etruscan color by using the formula given in your book, "Workshop Notes," page 170. Had a druggist to put it up.  
WM. H. SCHRAMM.

ANSWER:—There are various reasons why you cannot get a good Etruscan color with the formula referred to, among which may be cited the following: the grade of gold may be too low; the goods may not have been properly annealed, or they may not be utterly clean to take the color. We have submitted your question to an expert colorer who says the formula is an effective one. He thinks if you omit the beeswax that you will obtain the desired results. Martin Brunor's new book, The Practical Electroplater, contains admirable chapters on coloring.

ESTABLISHED 50 YEARS.

RANDEL, BAREMORE & BILLINGS,

IMPORTERS OF

DIAMONDS,

AND OTHER PRECIOUS STONES.

FINE PEARLS A SPECIALTY.

MANUFACTURERS OF

DIAMOND JEWELRY,

IN THE LATEST DESIGNS.

Diamonds Recut in Modern Styles or Repaired on Premises.

58 Nassau Street,  
29 Maiden Lane  
NEW YORK.

1 Tulp Straat,  
AMSTERDAM.

1 St. Andrews St.,  
Holborn Circus,  
LONDON, E. C.



TRADE MARK.

ESTABLISHED 1841.

CARTER, SLOAN & CO.,

MANUFACTURERS OF GOLD JEWELRY,

No. 15 MAIDEN LANE.

NEW YORK.

A. CARTER, JR.  
A. K. SLOAN.  
C. E. HASTINGS.

GEO. R. HOWE  
WM. T. CARTER.  
WM. T. GOUGH.

FACTORY, NEWARK, N. J.

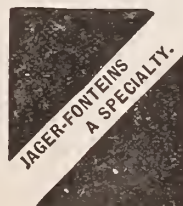

JOHN N. DISSELKOEN,

Gutter and Importer of

DIAMONDS

FACTORY,  
76 LANGEBLEEKERSPAD  
AMSTERDAM.

19 East 16th St.,  
NEW YORK.

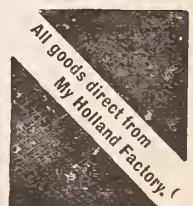



# SUGGESTIONS FOR WINDOW AND STORE DECORATION.

Members of the trade who think they have an attractive window are invited to send us a photograph, or a pen and ink or pencil sketch of the same, which will be published if we consider the window contains any originality or lesson.

## IDEA LXVII—EASTER WINDOW.

**T**HE window decoration designed by Dallas R. Cann, with J. H. Knerr, Camden, N. J., is admirably adapted to the Easter season. The window is trimmed

placed around them in neat order.

The bell has fine diamond brooches, link bracelets and neck chain pendants tastefully arranged on it. The bell rests on the

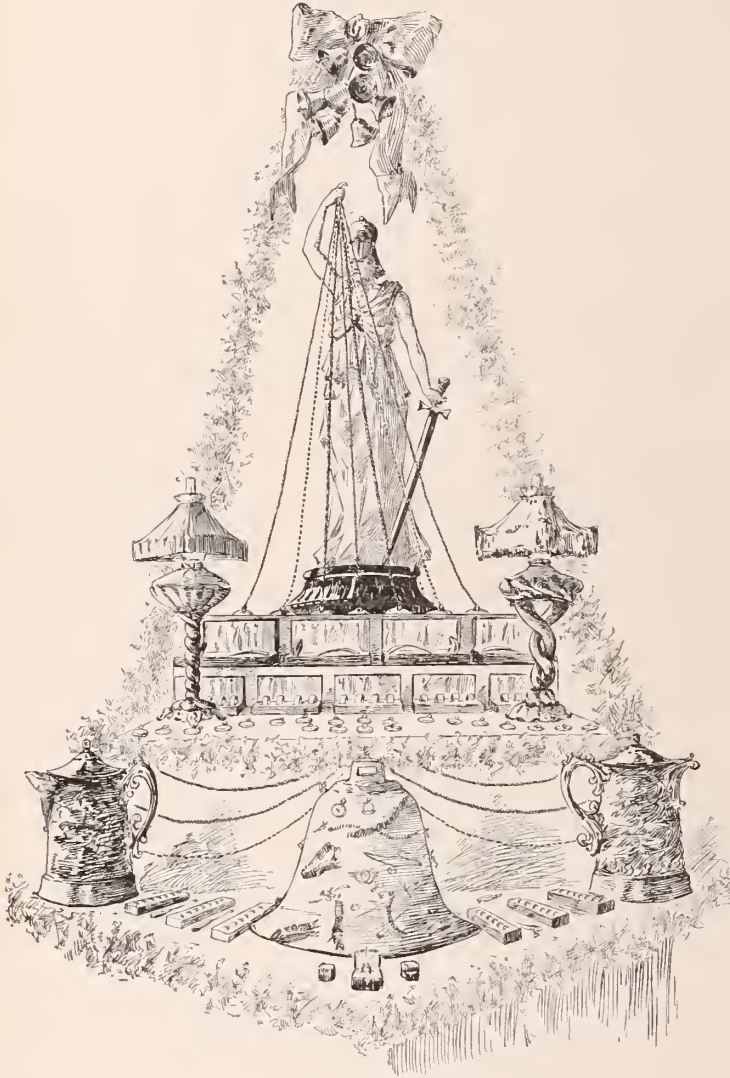

A TASTY ARRANGEMENT FOR AN EASTER WINDOW.

from the back corner and covered with white or cream silk, except the large bell which is covered with fine jewelers' cotton. The lower part of the window is tastefully arranged with small, long ring trays, holding 6 to 8 rings each, with silver trinkets

base of the window, with the top raised about half way between the lower platform and the next platform. From this second platform hang down on each side, above the bell, three lognettes. On this platform are laid out ladies' watches, gents'

vest chains, hair pins and ladies' Victoria chains, two silver lamps and one row of case goods; a few inches higher is another row of case goods, and on the top platform stands a bronze figure, which may represent Oestera, the deity to whose honor the Germanic races feasted at the opening of Spring. She has her hand raised, and on it are strung 10 ladies' lognettes and watch chains, each chain being connected with a ladies' watch in the front row. At the back are arranged gents' gold watches.

A few inches above the bronze are seven white paper bells, tied with a bow of white ribbon. Two strings of asparagus smilax are hung to each side corner of the window and arranged around the base of the window and the bottom and top of the two platforms.

### Hints in Brief.

W. W. Appel, Lancaster, Pa., gives away watches free; that is for some time past every visitor at the store was given a card, which entitled him to a chance on a watch. Some evenings ago the drawing was made.

The following advertisement recently appeared in an Indianapolis, Ind., paper:

**WANTED**—A young man to learn the jewelry business. Must be from good family, with thorough school education, one who is not his mamma's boss when father is absent, and who has not an appetite for cigarettes.

A blue etching with the words "Columbus discovering P. S. Bartlett" surmounting a globe on which stands P. S. Bartlett, while up the opposite side creeps Columbus with the flag of Spain in hand, to whom Bartlett with a courtly bow holds forth a watch, was an eccentric device used on stationery by P. S. Bartlett & Co., of Elgin, Ill., the past year.

## PATENT PANELED METAL CEILINGS

### Stamped Raised Panels.

ARTISTIC AND PERMANENT.

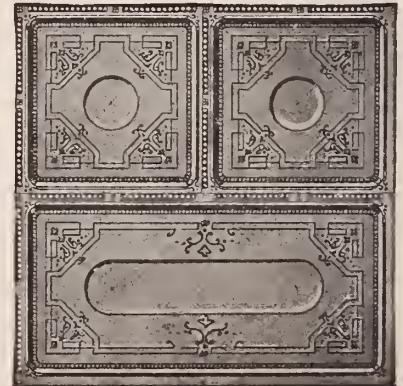

Easily applied in new buildings, and over old broken plaster or wood Ceilings. If interested in building or repairing, send stamp for Illustrated Catalogue, and state if **CHURCH, HALL, STORE, OFFICE, or SCHOOL** Ceiling is wanted. Address

**A. NORTHROP & CO., Pittsburg, Pa.**

## BIG RETURNS MADE FOR OLD GOLD AND SILVER.

Check Forwarded 24 Hours After Receipt of Consignment

# J. RATHBONE,

## GOLD AND SILVER REFINER. ASSAYER AND SWEEPSMELTER,

Nos. 1 to 9 Matthewson St., Cor. Cove, Providence, R. I.



**Boston.**

Ludwig Nissen, New York, called upon his friends in the Boston trade the past week.

At the annual meeting of the E. Howard Watch & Clock Co. in February the old board of officers was re-elected.

Buyers in town last week included: J. C. Lee, Gouverneur, N. Y.; George Henry, Bridgewater; H. W. Darling, Stoughton.

O. P. Burris, heretofore located on the second floor of the same building, now has a watchmaker's bench in Henry Cowan's store.

Charles W. Beals, the Milk St. jeweler, whose leg was broken Feb. 1st by a fall on the ice, is still confined to his bed, but improves slowly.

William S. Robinson, salesman for the Ripley-Howland Mfg. Co., is enjoying an outing at Orlando, Fla., Charles G. Perry covering his territory in northern New England meanwhile.

The E. Howard Watch & Clock Co. have decided to produce a higher grade watch and preparations are now on foot with a view to turning out the finest timepieces ever made in America.

Among the orders filled last week by Henry Cowan, was one from J. Fernandez, formerly of Boston, but now located in Surinam, Dutch Guiana, for an outfit of tools and other store equipments.

The old tower clock of the Chicago Board of Trade building has been replaced by a new clock built by the E. Howard Watch & Clock Co. It has a 13 foot illuminated dial and runs several dials in other parts of the building by means of shafting.

**The Attleboros.**

Thomas Percival, 20 years with Smith & Crosby, died Thursday.

Harry E. Carpenter is conducting the affairs of W. H. Wilmarth & Co.

William A. Bigelow, salesman for the Bates Button Co., returned from the west early last week and said "jobbers are only buying goods from hand to mouth."

E. S. Horton and J. H. Sturdy represented the town in the hearing before the Massachusetts Legislature, for the purpose of abolishing the grade crossings of the town.

Joseph B. Draper died Wednesday at the age of 79 years. Mr. Draper had been identified with the manufacturing jewelry business for over a half century. He was connected at one time with the firm of J. E. Draper & Co.

Handel N. Daggett, a twin brother of H. M. Daggett, a proprietor of many buildings devoted to the manufacture of jewelry, and at one time interested in the industry, died suddenly last Wednesday. He was sole proprietor of the Gold Medal Braid Co. and was interested in several banking and insurance institutions. Mr. Daggett represented the district in the Massachusetts Legislature several years.

**Canada and the Provinces.**

Charles Hanny, Kingston, Ont., died last week.

C. E. Young & Co., jewelers, Montreal, have sold out to H. J. Dreyfus & Co.

The Joseph Taylor Jewelry Co. (limited), of Hamilton, with a capital stock of \$3,000, have incorporated.

The premises of F. G. Lajoie, watchmaker and jeweler, 1461 St. Catherine St., Montreal, were broken into last week and about \$200 worth of jewelry was stolen.

The last of the Kent Bros.' auction sales, in Toronto, has been held. The celebrated Indian clock was purchased for \$425 by F. X. Cousineau, who thus possesses, next to the Toronto *World*, the best advertising medium in Canada.

E. R. C. Clarkson has been appointed

permanent liquidator of the Acme Silver Co., limited, Toronto. Proceedings were taken Thursday by J. A. Macdonald to set aside the appointment of E. R. C. Clarkson as liquidator of the company.

In the case of Edmund Eaves, insolvent, Montreal, a petition was presented Friday last in the Insolvency Court, by the Montreal Watch Case Co., asking that the curators and inspectors of the estate be ordered to accept an offer made by Fancher, Fils & Co., for the assets of the estate. Before judging on the merits of the case Judge Chasland, before whom the petition was presented, ordered that a meeting of the creditors be called to consider the matter.

J. C. Irwing, Hagerstown, Md., has applied for the benefit of the insolvency law.

**DIAMOND EXCHANGE BUILDING.**

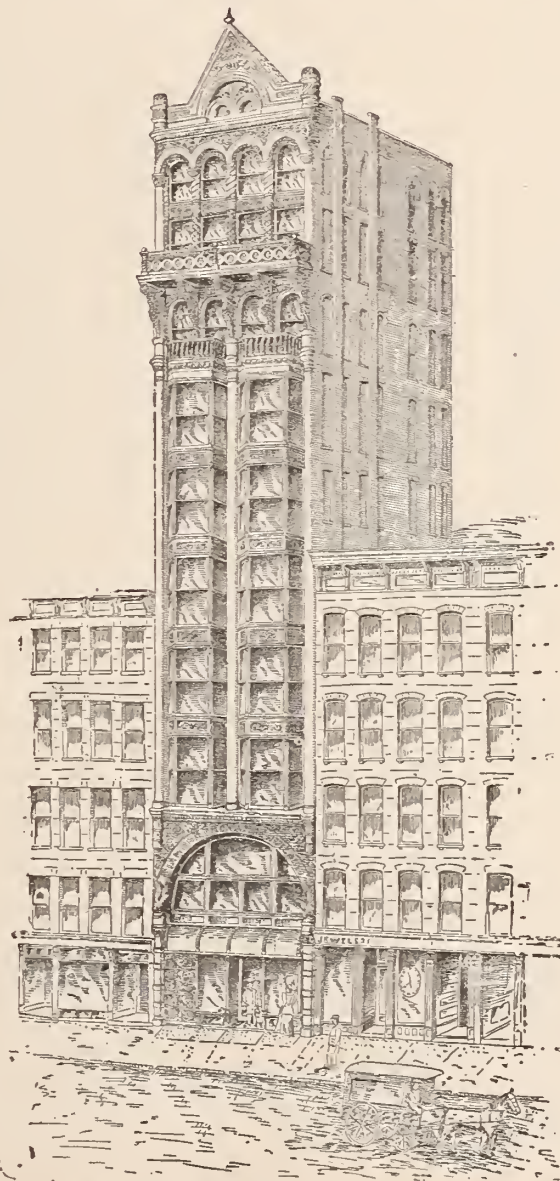

In the new fire proof, ten story

Diamond Exchange Building,

14 Maiden Lane.

**OFFICES**

of most modern construction, with abundance of light and air, rapid elevator, mail chute, steam heat, gas and electric light, exposed sanitary plumbing, oak cabinet trim, unique plate glass partition and quartered oak floors. at rentals from

**\$900.00**

Per Annum up.

Specially adapted for the Diamond and Jewelry Trade. Possession on or before May 1st, next.

For further particulars apply to

**E. A. Cruikshank & Co.,**

176 Broadway, N. Y.

**THE ELEVATOR IS NOW RUNNING.**





Traveling representatives may consider these columns open for the publication of any news or items of interest regarding themselves or their confreres.

**T**HE following traveling salesmen passed through Detroit last week: Mr. Copeland, Martin, Copeland & Co.; Al. Wagner, Leon J. Glaenger & Co.; Bob Wilcox, Rogers, Smith & Co.; Louis Fay Kirby, Mowry & Co.; A. M. Leibman, E. P. Reichhelm & Co.; F. M. Neefus, E. N. Welch Mfg. Co.; F. E. Alden, H. W. Wheeler & Co.; Maj. Brooks, Brooks & Pike; Mr. Steele, B. J. Bowden & Co.; Charles F. Ketcham, Riker Bros.; E. F. Badoux, Spencer Optical Mfg. Co. and Ketcham & McDougall; and J. E. Simonson, A. J. Hedges & Co.

T. J. Gardiner is now representing Geo. M. Baker, Providence, R. I., with excellent satisfaction.

On his recent return from a western trip, Manager Loeb, of the Wadsworth Watch Case Co.'s Chicago office, reported fair success in sales of new lines of cases.

Among the traveling men in Lancaster, Pa., the past week were: L. Witsenhausen, Sternberger & Witsenhausen; J. W. Block, for Charles Knapp; Herman Schwartz, Krementz & Co.; F. W. Bliss, Unger Bros.; J. H. Thompson, Bioren Bros.; N. Coughlin, for Wm. Link.

#### TALENTS OF A SALESMAN.

"Is he a good salesman?" asked one merchant of another, who was speaking of one of his traveling men.

"Yes, indeed," remarked the gentleman addressed. "He's a wonder. He can sell goods, lots of them, cheaper than the manufacturer can make them."

Traveling salesmen in Philadelphia the past week were: J. E. Simonson, A. J. Hedges & Co.; H. Scofield, Lincoln, Bacon & Co.; Chas. Duffy, Enos Richardson & Co.; B. Schloss, A. Wallach & Co.; Otto Wolf, Bippart & Co.; F. Mills, Shoemaker, Pickering & Co.; Wm. Wightman, R. F. Simmons & Co.; J. Imfield, Hendricks & Co.; J. Morrow, United States Watch Co.; and W. Brines, Crescent Watch Case Co.

Salesmen in Indianapolis last week included Dave Gunzburger; J. J. Sommers; W. S. Strauss, Jacob Strauss & Sons; A. J. Beck, Bawo & Dotter; J. W. Weiss, Henry E. Oppenheimer & Co.; H. Grabowski, Dattelbaum & Friedman; J. Sommers, Thos. Totten & Co.; J. E. Blake, Blake & Claffin; C. W. Battey, Waite, Mathewson & Co.; David Schwarz, Nicolas Muller's Sons; Geo. L. Paine, E. I. Franklin & Co.; Alfred Frank, Ilerzog, Goldsmith & Frank; and a representative of Rosenberger & Co.

The following travelers were noted in Chicago last week: J. D. Underwood, Champenois & Co.; J. J. Sommers; E. S. Robbins; J. J. Sullivan; S. Berger; John Hagan; G. C. Hudson, H. F. Barrows & Co.; Benj. Eichberg, Eichberg & Co.; C. A. Marsh, Marsh & Bigney; E. L. Mumford, Waite, Thresher Co.; Mr. Platt, Foster & Bailey; F. Sternthals, S. & B. Lederer; Mr. Rogers, Parks Bros. & Rogers; Geo. C. Booth, Hutchison & Huestis.

Traveling men in Boston last week included: Mr. Blecker, Wm. S. Hedges & Co.; M. Goodfriend, Goodfriend Bros. & Lassner; Mr. Friese and Fred. Lewis, Lewis, Kaiser & Luthy; Harry Walton, Wadsworth Watch Case Co.; W. H. Tarlton, Wightman & Hough Co.; Fred. Clarkson, Snow & Westcott; T. B. Wilcox, Pairpoint Mfg. Co.; S. O. Bigney, Marsh & Bigney; Charles H. Barney, Middletown Plate Co.; Henry G. Thresher, Waite, Thresher Co.; Sumner Blackinton, W. & S. Blackinton; Mr. Tirrell, M. Fox & Co.; L. Lilienthal, Bruhl Bros. & Co.; C. E. Hancock, Hancock, Becker & Co.; Walter Gardiner, D. Wilcox & Co.; A. L. Stearns.

Among the traveling men looking after trade in Syracuse, N. Y., the past week were: Frank G. Moyer, Max Freund & Co.; W. S. Campbell, Day & Clark; Monroe Engelsman, Maurice Weil; Paul Gesswein, F. W. Gesswein; G. E. Herrmann, Gorham Mfg. Co.; Frank W. Harmon, M. B. Bryant & Co.; Geo. W. Smith, Carter, Sloan & Co.; S. P. Weare, A. F. Towle & Son Co.; Chas. Berliner, M. Freed & Co.; F. J. Curtis, R. H. Ingersoll & Bro.; H. A. Scofield, Lincoln, Bacon & Co.; F. W. Martini, A. Troeschler & Co.; S. D. McChesney, Wm. B. Kerr & Co.; F. B. Tuck, A. Feigl; G. D. Merrill, Merrill Bros.; Joe Burrill, Dattelbaum & Friedman; M. L. Jacoby, Providence Stock Co.; Mr. Ketcham, Brooklyn Watch Case Co.; W. Smellie, Geo. B. Hurd & Co.; Zack A. Oppenheimer, Seckels & Oppenheimer.

#### Death of an Old-time Jeweler.

BRIDGEPORT, Conn., March 3.—Death has suddenly removed one of Bridgeport's prominent citizens in the person of Samuel Wilmot.

Samuel Wilmot was born in New Haven in 1808, and at an early age came to this city and started in business with his brother, Thomas P. Wilmot, succeeding Brazilla Benjamin in the watch and jewelry business in 1826 or 1827. The business was then conducted in one of the stores now occupied by N. Buckingham, 387 Water St. There was also a branch of the business carried on in Savannah, Ga., of which Samuel Wilmot was the head. This kept him south the greater part of the time, he going to Savannah in Winter and spending his Summers here.

About 1830 the business in this city was removed to Wall St., at the corner of Middle, where it was conducted until the

death of Thomas, which occurred some 12 years later. Samuel then sold out the business here and gave his whole time to the southern branch, where he remained up to about the time of the late war, returning to this city during the war, where he has lived ever since. While living here he has been identified with various institutions.

#### Philadelphia.

S. Lubin is preparing an extensive optical exhibit for the Antwerp Exposition.

Messrs Hennegen and Bates, of Hennegen, Bates & Co., Baltimore, Md., spent several days on a social visit to Philadelphia last week.

Wm. E. McCall is rapidly gaining strength at Atlantic City, after a severe spell of sickness. He is accompanied by Mrs. McCall, and is stopping at the Hotel Richmond.

George W. Gilbert, manager of the Pottstown store of the M. H. Betz Jewelry Co., has obtained an injunction to restrain them from negotiating a \$3,000 mortgage which they hold against him, alleging that it was procured by fraud.

Emma, alias Lena Bailey, the more or less notorious young woman, whose arrest was reported in last week's CIRCULAR, on the charge of defrauding various jewelry houses, had a hearing before Magistrate Milligan Wednesday and was held in \$2,000 bail for trial.

J. Alexander Simpson, a widely-known member of the Philadelphia bar and of the Masonic fraternity, died suddenly on Tuesday evening last at his home in Narberth, Montgomery county, of neuralgia of the heart. In early life he chose the trade of watch case making and worked at it for several years. When about 31 years of age he decided to study law.

#### Springfield, Mass.

L. B. Coe, who is now settled in his new quarters, is crowded with work in his repairing and diamond setting department. Mr. Coe has fitted up a room upstairs and has every facility for doing fine work.

Jeweler Davidson was made happy the past week by the announcement that the two men who robbed his store a week or two ago had been captured in Chicopee. He went to that city with Inspector Quilty, but the men were not the criminals and were released.

In the production of silver mounted belts Unger Bros., Corbin Building, 192 Broadway, New York, were the first firm to use moiré antique silk ribbon. These articles, the prices of which have been reduced, as may be seen in the firm's advertisement on another page, are very handsome and have won a popularity almost unprecedented in the line of manufacture they represent.



**News Gleanings.**

J. E. Withey will open a new store in Flint, Mich.

Geo. M. Yarnell, Senecaville, O., has removed to Columbus, O.

R. M. York, formerly of Malone, N. Y., has located in Champlain, N. Y.

R. J. Cushing, Bangor, Me., spent last week in Philadelphia, Pa., on business.

William Beatty, of West Virginia, has opened a repair shop in Harrisonburg, Va.

A. Colins was arrested last week in Topeka, Kan., for peddling jewelry without license.

Fred. C. Parshall, formerly with C. R. Burch, Cooperstown, N. Y., is now with Frank O. D. vis, Northampton, Mass.

The wife of Thomas F. Parker, Maynard, Mass., died at her home in that town last Friday morning.

M. J. Beckley, of Harrisburg, Pa., has purchased the store of T. H. Bosworth, Millersburgh, Pa.

It is "Wiesman & Son" now at Millbury, Mass., the youth having arrived and tipped the scales February 28th at 9¾ lbs.

H. M. & H. S. Tower have secured the corner store in the Hildreth Hotel, Charles City, Ia., and will put in a jewelry stock.

S. O. Boden, with Bell Bros. Co., Ogdensburg, N. Y., has been spending a brief vacation at his home in Cooperstown, N. Y.

A notice of the dissolution of the Anderson Jewelry Co., Milwaukee, Wis., has been filed by W. D. Anderson, president of the company.

The store of Moses Latinskie, Verona, N. Y., dealer in jewelry, etc., suffered by fire last week to the extent of \$1,000. He lost everything.

V. J. Durkee, for 13 years with L. Sunderlin & Co., and B. E. Brown, Rochester, N. Y., is now in business on his own account at 104 Wilder building.

A ledge of onyx has been discovered in the Big Bend country, Nebraska. Slabs 18x20 inches may be taken out, and it shows 10 distinct shades of color.

Thieves entered the store of Jason Foster, 102 Munroe St., Lynn, Mass., early on the morning of February 26 and secured silverware and jewelry valued at \$228.

George T. Leaman and J. T. Rupert were arrested a few days ago in Harrisburgh, Pa., for robbing the jewelry store of Mayer Cohn, 1204 N. 3d St., of goods valued at \$30.

In Geo. E. Wilkins' store, Syracuse, N. Y., renovation has been the order of the day during the past week, and the store presents a greatly improved appearance.

J. C. Grasborg, jeweler, Schuyler, Neb., refused to pay the occupation tax, and a watch valued at \$35 was taken from his stock. He has begun suit for its recovery.

While C. A. Huck, North Bend, Neb., was at supper a few days ago, some one broke into the back door of his jewelry store

and stole two trays of watches and cases and one tray of chains.

Theodore O. Gotsch, son of Julius H. Gotsch, formerly a prominent jeweler of Kendallville, Ind., now deceased, died at his home in Ft. Wayne, on Tuesday afternoon last, of consumption.

The window of Adam Egolf's jewelry store, Shenandoah, Pa., was broken into at an early hour last Monday morning and jewelry stolen to the value of \$40. No arrests have as yet been made.

When Frank Baker was arrested in Buffalo, N. Y., last week, a belt was found around his waist which contained eight watches identified as having been stolen from Yallowitch's Canal St. jewelry store.

S. W. Hall, who has for several years past been manager of C. F. Godfrey's branch store at Falmouth, Mass., has bought the latter's Wareham store. Mr. Godfrey's future business has not yet been announced to the public.

J. C. Lee, Gouverneur, N. Y., is holding an auction prior to his retirement from business. E. S. Laberdee has made arrangements to purchase the fixtures of the store and become Mr. Lee's successor with a new stock of goods.

The Omaha Watch Club Co., of Omaha, Neb., have sued John C. Dingman as constable, and Patrick Ford and Jack Morrison for \$1,000 on the official bond of Dingman. The grounds are an alleged failure of duty in a replevin suit.

H. Collins, jeweler, 328 Marietta St., Atlanta, Ga., is missing from the city, and the police have been requested to arrest him. He is said to have taken away about a dozen watches with him, which were left with him for repairs.

On Feb. 24th M. F. Doering purchased the interest of his partner, R. H. Robinson, in the business of Doering & Robinson, Anniston, Ala. Mr. Doering assumes all liabilities of the firm, and will continue the business under his own name.

William Vinton, jeweler, Nauvoo, Ill., has brought suit against Martin Kelley, Lutz Schaffer and Edward Ebert, of this city, for \$6,000 damages, alleging that they were instrumental in having him incarcerated in the county jail on a charge of blackmail.

Word comes from the opal mines near Caldwell, Idaho, of the finding of the largest opal in the world. It is said to be as large as a hen's egg and without a flaw. It is estimated that the gem will dress 325 karats and prove of the highest quality and immensely valuable.

William Frederick Poole, L.L.D., the celebrated librarian who died at his home at Evanston, Ill., Thursday, after an illness of several days, was for a short time during his early life in the jewelry business. He learned the trade of watchmaker and jeweler when a young man.

In the Circuit Court at Owingsville, Ky., last week, Ned Glennalian and Ed. Ghaliers

were arraigned on the charge of burglary. The former was given three years and six months, and the latter one year in the penitentiary. These two men broke into Robert Gault's jewelry store and stole a hatful of watches and about \$30 in money, one night last Fall.

Alderman Stephens, of Altoona, Pa., last Monday afternoon gave a hearing to U. Kleiman, a jeweler, whose shop is at 1015 Bridge St.; the charge against him being the stealing of the works from a watch left at his shop for repair by Harry Ritz. After hearing the evidence the alderman held Kleiman for court in the sum of \$200 bail.

Greenleaf & Crosby, Jacksonville, Fla., have one of the finest and best selected stock of goods in the Southern States. At St. Augustine their branch store, in the Alcazar Hotel, under the able management of Charles Fuller, displays a choice stock such as is seldom seen outside the largest cities of the north. Another branch store has been recently opened by Greenleaf & Crosby, at Palm Beach, Lake Worth, in H. M. Flagler's new hotel, the Royal Poinciana, in which they carry a stock as rich and perhaps more extensive than the one in St. Augustine. D. Greenleaf, of the firm, has one of the finest and best appointed orange groves of 1,000 acres in the State. It is situated on Lake George, St. John's River, on which are produced the best oranges to be found anywhere.

**IF YOU WANT A POSITION  
YOU NEED A SALESMAN  
YOU NEED A WORKMAN  
YOU DESIRE TO EXCHANGE  
YOU WANT A PARTNER  
YOU WISH TO SELL OUT  
YOU HAVE TOOLS TO SELL  
YOU HAVE A PLACE TO LET  
YOU WANT ANYTHING**

USE THE

**SPECIAL NOTICE PAGE**

OF THE

**JEWELERS' CIRCULAR,**

**Published Every Wednesday.**

To insure Publication of Advertisement in current week, copy should be received not later than Monday Night.

**OLDEST PUBLICATION**

Of all the Jewelry Journals.

**Jewelers' Circular Publishing Co.,**

**189 BROADWAY, NEW YORK.**

**ESTABLISHED 25 YEARS.**



# CLASSIFIED INDEX TO ADVERTISEMENTS.

All Advertisements are entitled to one insertion under proper heading. Extra insertions, \$6.00 per annum.  
Extra Headings, \$12.00 per annum.

	Page.		Page.		Page.
<b>Art Pottery, Bric-a-brac, Etc.</b>		<b>Gold Jewelry.</b>		<b>Ring Makers.</b>	
Ahrenfeldt, Charles & Son, 50-52-54 Murray St., N. Y. ....	38	Carter, Sloan & Co., 15 Maiden Lane, N. Y. ...	27	Bryant, M. B. & Co., 10 Maiden Lane, N. Y. ...	40
Bing, Ferdinand & Co., 106 Grand St., N. Y. ...	38	Johnson, R. M., 67 Washington St., Chicago, Ill. ...	22	Bowden, J. B. & Co., 192 Broadway, N. Y. ....	7
Borgfeldt, Geo. & Co., 18, 20 & 22 Washington Place, New York. ....	41	Kremetz & Co., 182 Broadway, N. Y. ....	2	Hildreth Mfg. Co., 53 Maiden Lane, N. Y. ....	8
Hinrichs & Co., 29 & 31 Park Place, N. Y. ....	43	Larter, Elcox & Co., 21 & 23 Maiden Lane, N. Y. ....	7	Wood, J. R. & Sons, New York. ....	42
Straus, L. & Sons, 42 to 48 Warren St., N. Y. ...	37	Pfeil, Chas. II., Chicago, Ill. ....	22	<b>Rubber Stamps and Type.</b>	
<b>Assayers &amp; Refiners.</b>		Reddall, John W., Newark, N. J. ....	16	Dietz, Wm. H., Chicago, Ill. ....	24
Baker, Geo. M., Providence, R. I. ....	18	Schwartz, W. H., & Co., Newark, N. J. ....	8	<b>Sample Trunks.</b>	
Clark, J. L., Philadelphia, Pa. ....	43	Smith, Wm., & Co., 5-7 Maiden Lane, N. Y. ...	40	Crouch & Fitzgerald, 161 Broadway, N. Y. ...	2
Goldsmith Bros., 63 & 65 Washington St., Chicago, Ill. ....	21	Unger Bros., 192 Broadway, N. Y. ....	12	<b>Silver Mounted Ebony Goods.</b>	
Howard, S. P., 33 Maiden Lane, N. Y. ....	44	Webster, G. A., Chicago, Ill. ....	4	Deitsch Bros., 7 E. 17th St., N. Y. ....	2
Le Long, L. & Bro., Newark, N. J. ....	44	<b>Horological Schools.</b>		<b>Silver Plated Ware.</b>	
Rathbone, J., Providence, R. I. ....	28	American Horological Institute, Lancaster, Pa. ...	24	Pairpoint Mfg. Co., New Bedford, Mass. ....	5
Schawel, J. & Co., 29 John St., N. Y. ....	44	Chicago Watchmakers' Institute, Chicago, Ill. ...	24	Rogers, Smith & Co., Meriden, Conn. ....	15
<b>Auctioneers.</b>		Elgin Horological School, Elgin, Ill. ....	22	<b>Sterling Silver Novelties.</b>	
American Syndicate of Jewelers' Auctioneers, New York and Washington. ....	2	Parson's School for Watchmakers, Peoria, Ill. ...	22	Haskell, H. C., Corbin Building, N. Y. ....	34
French, J. H., P. O. Box 2775, N. Y. ....	17	<b>Hotels.</b>		<b>Sterling Silverware.</b>	
Prince, J., 137 Broadway, N. Y. ....	44	Gibson House, Cincinnati, O. ....	22	Alvin Mfg. Co., 860 Broadway, N. Y. ....	17
Rich, H. M. & Co., Boston, Mass. ....	4	<b>Insurance.</b>		Bachrach & Freedman, 1 & 3 Union Sq., N. Y. ...	10
Scott, De B. O., 20 Murray St., N. Y. ....	5	Jewelers' & Tradesmen's Co., N. Y. ....	9	Campbell-Metcalf Silver Co., Providence, R. I. ...	2
<b>Badges, Medals, Etc.</b>		<b>Jewelers' Findings.</b>		Reed & Barton, 37 Union Square, N. Y. ....	23
Irons & Russell, Providence, R. I. ....	7	Lind, Thos. W., Providence, R. I. ....	18	Shiebler, Geo. W., Co., 179 Broadway, N. Y. ...	4
Schlechter, G. A., Reading, Pa. ....	43	<b>Jewelers' Lamps.</b>		Towle Mfg. Co., Newburyport, Mass. ....	43
Stockwell, E. R., 19 John St., N. Y. ....	43	Hinrichs & Co., 31 Park Place, N. Y. ....	35	Wallace, R. & Sons Mfg. Co., 3 Park Place, ...	6
Willson, Chas. G., Reading, Pa. ....	17	<b>Jewelry Mailing Boxes.</b>		Whiting, F. M. & Co., North Attleboro, Mass. ...	37
<b>Chrome Steel.</b>		Am. Railway Supply Co., 24 Park Place, N. Y. ...	37	Wood & Hughes, 10 John St., N. Y. ....	38
Chrome Steel Works, Brooklyn, N. Y. ....	42	<b>Jewelry, Silverware and Optical Cases.</b>		<b>Spectacle and Eyeglass Cases.</b>	
<b>Chronometers.</b>		Steinhaus, Theo. C., 10 Maiden Lane, N. Y. ...	4	Birmingham, Wm. & Co., 728 Arch St., Phila. ...	44
Bliss, John & Co., 129 Front St., N. Y. ....	8	<b>Jobbers, Watches, Diamonds, Etc.</b>		White, W. B. & Son, Boston, Mass. ....	4
<b>Clocks, French, English and American.</b>		Allen, Benj. & Co., Chicago, Ill. ....	23	<b>Stem Winding Attachments.</b>	
Atwater, W. H., 10 Maiden Lane, N. Y. ....	35	Brethauer Watch and Jewelry Co., Chicago, Ill. ...	24	Abbott, Henry, 2 Maiden Lane, N. Y. ....	26
Jacques, Chas., Clock Co., 22 Cortlandt St., N. Y. ....	44	Cross & Beguelin, 17 Maiden Lane, N. Y. ....	2	<b>Thimbles.</b>	
<b>Cut Glass.</b>		Friedlander, R., L. & M., 65, 67 Nassau St., N. Y. ....	42	Ketchum & McDougal, 198 Broadway, N. Y. ...	7
Mt. Washington Glass Co., New Bedford, Mass. ....	37	Myers, S. F. & Co., 48 Maiden Lane, N. Y. ...	44	<b>Tortoise Shell Goods.</b>	
<b>Diamond &amp; Precious Stone Importers.</b>		Oppenheimer Bros. & Veith, 35 Maiden Lane, N. Y. ....	38	Potter, W. K., Providence, R. I. ....	5
Disselkoen, John N., 19 E. 16th St., N. Y. ...	27	<b>Leather and Silver Goods.</b>		<b>Tool Manufacturers and Dealers.</b>	
Eichenberg, Julius, Providence, R. I. ....	26	Deitsch Bros., 7 E. 17th St., N. Y. ....	2	American Watch Tool Co., Waltham, Mass. ...	19
Falkenau, Oppenheimer & Co., 40 Maiden Lane, N. Y. ....	44	<b>Musical Boxes.</b>		Bullock, O. W. & Co., Springfield, Mass. ....	4
Fera, Henry, 10 Maiden Lane, N. Y. ....	26	Jacot & Son, 298 Broadway, N. Y. ....	2	Hardinge Bros., Chicago, Ill. ....	24
Hedges, Wm. S. & Co., 170 Broadway, N. Y. ...	26	<b>Optical Goods.</b>		Logan, A. J., Waltham, Mass. ....	5
Kipling, E. E., 182 Broadway, N. Y. ....	44	Berger, Albert & Co., 47 Maiden Lane, N. Y. ...	42	Moseley & Co., Elgin, Ill. ....	22
Kipling, R. A., Hays Bldg., N. Y. ....	26	Geneva Optical Co., Chicago, Ill. ....	22	Oliver, W. W., Buffalo, N. Y. ....	22
Lorsch, Albert & Co., 37 Maiden Lane, N. Y. ...	44	Kirstein's, H. E., Sons Co., Rochester, N. Y. ...	43	<b>Trunks and Traveling Bags.</b>	
Randel, Baremore & Billings, 29 Maiden Lane	27	Queen & Co., Philadelphia, Pa. ....	10	Crouch & Fitzgerald, 161 Broadway, N. Y. ...	26
Rothschild, M. D., 41 & 43 Maiden Lane, N. Y. ...	44	Spencer Optical Mfg. Co., 15 Maiden Lane, N. Y. ...	40	<b>Watch Manufacturers.</b>	
Smith, Alfred H. & Co., 182 Broadway, N. Y. ...	26	The Nous Verrons Co., Boston, Mass. ...	8	Charmilles Watch. ....	19
Tannenbaum, L., & Co., cor. Maiden Lane and Nassau St., N. Y. ....	15	<b>Office Building.</b>		<b>Watch Case Manufacturers.</b>	
<b>Diamond Jewelry.</b>		Cruikshank, E. A. & Co., 176 Broadway, N. Y. ...	43	American Watch Case Co., Corbin Building, New York. ....	44
Jeanne, Paul, Bradley Bldg., N. Y. ....	40	Diamond Exchange Building, 14 Maiden Lane. ...	29	The Planchamp & Becker Co., Chicago, Ill. ...	24
Leonhardt & Curran, 44½ Maiden Lane, N. Y. ...	8	<b>Paneled Metal.</b>		<b>Watch Dials.</b>	
<b>Engraving Machines.</b>		Northrop & Co., Pittsburgh, Pa. ....	28	O'Hara Waltham Dial Co., Waltham, Mass. ...	44
Francis, A. E., Cleveland, Ohio. ....	43	<b>Pens, Pencil Cases, Etc.</b>		<b>Watchman's Clocks.</b>	
<b>Fine Stationery.</b>		The Boston Pen Co., Boston, Mass. ....	4	Hausburg, O. E., 41 Maiden Lane, N. Y. ....	44
Parsons & Greene Co., 18 Murray St., N. Y. ...	5	<b>Patents.</b>		<b>Watch Importers.</b>	
<b>Gold and Silver Plating Works.</b>		Belt, C. T., Washington, D. C. ....	26	Hyde's, J. E., Sons, 22 Maiden Lane, N. Y. ...	38
Bolstad Mfg. & Plating Co., Chicago, Ill. ....	22	<b>Platinum Importers.</b>		<b>Watch Keys.</b>	
<b>Gold and Rolled Plate Jewelry.</b>		Schawel, J. & Co., 29 John St., N. Y. ....	44	Clark, A. N., Plainville, Conn. ....	2
Foster & Bailey, Providence, R. I. ....	3			<b>Watch Repairers.</b>	
Read, M. L. & Co., Providence, R. I. ....	3			Muller, Hugo, Chicago, Ill. ....	22
				Henry, Peter, Cincinnati, O. ....	22
				<b>Watch and Clock Signs.</b>	
				Excelsior Sign & Mfg. Co., Chicago. ....	25



## Special Notices.

Rates 75c. per insertion for notices not exceeding 3 lines (25 words); additional words 2 cents each. If answers are to be forwarded, postage stamps must be enclosed. Two insertions, 15 per cent. off; three insertions, 20 per cent. off; four insertions or more, 25 per cent. off. Payable strictly in advance. Display cards on this page will be charged at \$2.00 per inch for first insertion, subject to same discount above for subsequent insertions.

Under the heading of **Situations Wanted** on this page advertisements will be inserted for **One Cent a Word**. This offer refers to **Situations Wanted only**. Payable strictly in advance. If answers are to be forwarded, postage must be enclosed.

## Situations Wanted.

Notices under this heading **ONLY** are charged at one cent a word, payable strictly in advance. If answer are to be forwarded, postage must be enclosed.

**A JEWELER** wants position with a wholesale or retail store, to take charge of shop, making and repairing. Address Metallurgist, care **JEWELERS' CIRCULAR**.

**WANTED, SITUATION**—Manager of a business for two years past. Do all branches of work—watchmaking, engraving, seal making, jobbing, selling, buying. Box 695, What Cheer, Ia.

**SITUATION WANTED** by watchmaker who thoroughly understands his business. Competent on chronographs and French clocks. Does all kinds of jewelry repairing. Good salesman. Address "Energetic," care **JEWELERS' CIRCULAR**.

**SITUATION** wanted by first-class watchmaker, jewelry repairer, clerk and do common engraving; young man and married; have bench and tools. Address 315 Day St., Decorah, Iowa.

**A FIRST-CLASS** watchmaker seeks position as foreman, manager or otherwise, in a good house, town or country. Competent in all complicated and plain watch work. All New York references. English; speaks and writes French. Address Pivot, 361 Cumberland St., Brooklyn, N. Y.

**WATCHMAKER**, 10 years' experience in largest cities in the United States, wants place at once. Can do all kinds of work—jobbing, fine engraving and fine watch repairs on complicated work, striking watches, etc. Will go on percentage in a small town if the place is lively. Best references, or bonds if desired. Address Box 348, Madison, Minn.

**SITUATION WANTED** by first-class watchmaker and optician. Experienced. Position permanent. Salary \$20.00 per week. Married. Address G. B., 95 Brenton St., Cleveland, Ohio.

**YOUNG MAN** wants position where he can learn the jewelers' trade. Good engraver; have samples. Good references and industrious. Address Engraver, care of **THE JEWELERS' CIRCULAR**.

**SITUATION WANTED** as watch and clock maker; also jewelry repairer; age 21; speaks English and German; good references. Address A. Gunther, 875 Sixth Ave., New York.

**TRAVELING SALESMAN** with established trade wants two manufacturers' lines on commission to sell retail trade. Address "E," care **THE JEWELERS' CIRCULAR**.

**POSITION** wanted as watchmaker, salesman and engraver; full set of tools and best of references; single; location no object, but must be a permanent position. Address H. B. G., care of **THE JEWELERS' CIRCULAR**.

**ENGRAVER AND JOBBER**.—Plain and ornamental engraver wants position where he can learn jewelry jobbing. Can do some gilding and etching; work low. Address Reliable, care of **THE JEWELERS' CIRCULAR**.

**BY** competent, first-class watchmaker, 30 years of age; strictly temperate. Can do jewelry jobbing and clock work. Good set of tools, lathe and attachments. Had present position about 3 years. Best of reference as to character, etc. Those wanting cheap man need not apply. Please state salary in first letter. R. Jandon, 55 E. Town St., Columbus, O.

**SITUATION WANTED**.—By a young man, 23 years of age, as watchmaker and engraver, and salesman. Am a good all round man for store and have good references and full set of tools. Address O. R. F., 403 N. 4th St., Steubenville, Ohio.

**BY YOUNG MAN**, single, eight years' experience as jeweler, also do clock repairing and wait on store. No bad habits. Best references. Address 872 W. Baltimore St., Baltimore, Md.

**SITUATION WANTED** by young man, single, age 27, as watchmaker, jewelry jobber and plain engraver. Address W. M. M., care of **THE JEWELERS' CIRCULAR**.

**SITUATION WANTED**—By young man, 18 years old; place to learn jewelers' trade; references. Address F. A. M., 220 Cook Ave., Meriden, Conn.

**SALESMAN** with a large personal acquaintance with retail jewelry trade in Buffalo and vicinity wishes to represent a few manufacturers on commission. Address Reference, care **THE JEWELERS' CIRCULAR**.

**SITUATION WANTED** by an A1 watchmaker, jewelry jobber and engraver. Can repair repeaters, chronographs and all other fine watches; 16 year at the bench; good salesman; sober and reliable; good set of tools; A1 references. Address P. B. L., P. O. Box 412, Winchester, Ill.

**WORK WANTED FOR JEWELERS, SILVERSMITHS, ENGRAVERS, DESIGNERS, WATCHMAKERS, CASEMAKERS, TOOLMAKERS, ETC. ONLY WORKMEN WITH GOOD TESTIMONIALS FROM PREVIOUS EMPLOYERS ARE RECOMMENDED.**  
ADDRESS,  
**JEWELERS' RELIEF ASSOCIATION,**  
11 MAIDEN LANE, N. Y.

## To Let

**TO LET**.—A large office, 20x40, first floor, No. 11 Maiden Lane. \$60 a month.

**TO LET AT LOW RENT**—Two very desirable offices, one and two flights up, in building, No. 12 Maiden Lane. For particulars apply to Lissauer & Co., 12 Maiden Lane, N. Y.

**FOR RENT** in Corbin building, 11 John St., sixth floor, half of an office with or without large safe convenient for jeweler. For further particulars, address the janitor of the building.

**BROADWAY STORE** near the Post Office; desirable location; moderate rent; lease. Apply on premises, 2 Astor House.

## Miscellaneous.

**I BUY JEWELRY STOCKS**—Manufacturers, jobbers and retailers desiring to dispose of surplus or entire stocks of diamonds, watches and jewelry can find quick cash buyer by addressing Stephen S. Harmon, 134 East 96th St., New York City.

## DEMAGNETIZING.

**PERFECT WORK**—Watch repairing in all its branches; all work warranted. Winslow & Penney, 608 Masonic Temple, Chicago.

**FOURTEEN** karat gold solder that will flow on eight karat work; makes a hard solder job a pleasure. With this solder there is no danger of melting low karat specs. No white joints on rings. It is just what you want. Sample by mail 25 cents. F. W. Hall, Sterling Silver Novelties, Columbus Memorial Building, Chicago, Ill.

**NOTICE**—Any one having a stock of jewelry which they desire to sell, cheap, would do well to correspond with J. C. L., Gouverneur, N. Y.; town must have at least 5,000. When you write state full particulars, if you wish to receive attention.

**I HAVE** a nice line of optical goods, including a fine ophthalmoscope, focometer, and Geneva spectacle cabinet; all inventories little over \$400. What have you to exchange? Watches, diamonds, silverware or "brown-stone front?" Address J. C. L., Gouverneur, N. Y.

**WHO** wants to exchange a stock of jewelry for clear lots in Denver, or lots and stock in a fine growing summer resort, established about four years; stock has paid 20 per cent. in cash dividends. Correspondence solicited. Address REAL ESTATE, Box 346, Gouverneur, N. Y.

**WANTED**—Engraving machine, also optometer for watches, or anything I can use. Address W. A. Sherwood, care **JEWELERS' CIRCULAR**.

## For Sale.

**FOR SALE**.—A first class polishing lathe; all in good repair, at a low price for cash. Address G. W. Brown, 113 Point St., Providence, R. I.

**FOR SALE**.—Stock and fixtures of fine jewelry store in the booming city of Niagara Falls. To the right man, a chance of a life time. Enclose stamp for particulars to Dr Owen, Medina, N. Y.

## FOR SALE

### IN CHICAGO.

*An old established Retail Jewelry Business on a very prominent corner in the business portion of the city. Fine Fixtures and a Clean Stock. A big bargain may be obtained, as owner wishes to retire.*

Address C. B. S., care **JEWELERS' CIRCULAR**.

## FOR SALE.

The Old Established Jewelry Business of G. A. SCHULTZ (Dec'd), is for sale at a great bargain. New fixtures throughout; good location. Address **HELENA SCHULTZ, Ex'trix,** Corner 7th & Market Streets, LOUISVILLE, KY.

## FACTORY AND OFFICE TO RENT FROM MAY 1ST.

Desirable office on first floor with factory on fourth floor. John St., between Broadway and Nassau St. Office, 25x40; factory 25x75. Both connected by elevator and speaking tube. Factory well lighted and ventilated by four high sky-lights. Steam power according to wants. Rent \$2,000, or factory alone \$1,000. Address A. B. care **JEWELERS' CIRCULAR**.

## TO LET.

One of the most desirable Offices

— IN THE —

**HAYS BUILDING,**  
21 and 23 MAIDEN LANE.

APPLY AT OFFICE OF THE BUILDING.

**\$5,000** for long established retail Jewelry business in city of 100,000 inhabitants;

**YEARLY PROFIT ABOVE EXPENSE, \$3,500.** Can be greatly increased by additional capital if desired.

Satisfactory reasons for selling given to parties with necessary cash capital. Address, **CHANCE** care of **THE JEWELERS' CIRCULAR**.

**A LARGE FIRST FLOOR OFFICE,**  
189 BROADWAY,

Directly Opposite John Street.

Occupied for many years by Leroy W. Fairchild. Also another desirable suite of offices in this Modern Building at a very moderate rental.

**LEONARD J. CARPENTER,**  
41 LIBERTY STREET.



The Latest Patents.

ISSUE OF FEBRUARY 27, 1894.

515,411. COLLAR OR SCARF STUD. WILLIAM H. PEER, Flushing, N. Y.—Filed April 12, 1893. Serial No. 470,003. (No model.)

In a collar button and scarf stud having the retaining head and stem connected by a ball and socket joint, the socket formed in the main stem and having



the slot parallel with the axis of said stem, for the stem of the ball, said ball rigidly attached by its stem to the inner side of the retaining head and the retaining head having a flange and a notch in the flange to lap on the main stem of the stud.

515,538. METHOD OF DECORATING GLASS. ALBERT STEFFIN, New Bedford, Mass.—Filed June 7, 1888. Serial No. 276,392. (No specimens.)

The method of decorating glass to give it the appearance of being constructed in sections of stained

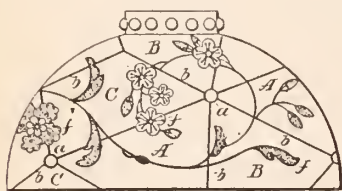

glass, consisting in coloring the surface of the glass and dividing the colored surface into segments by dense or opaque raised boundary lines of distinct color and finally incorporating said coloring matter with the glass by heat.

515,539. ARTICLE OF GLASSWARE. ALBERT STEFFIN, New Bedford, Mass.—Original application filed June 7, 1888. Serial No. 276,392. Divided and this application filed April 12, 1893. Serial No. 470,139. (No model.)

As a new article of manufacture, an article of glassware having its surface ornamented or decorated, and



divided into sections by opaque dividing lines, the latter projecting out from the surface of the article to give it the appearance of being constructed in sections of stained glass.

Expired Patents.

EXPIRED FEB. 27, 1894 GRANTED FEB. 27, 1877.

187,753. MANUFACTURE OF WATCH-

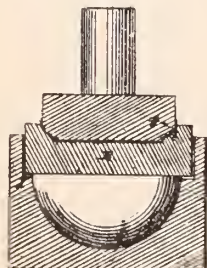

CASES. F. ECAUBERT, New York, N. Y.—Filed Jan. 31, 1877.

The female die B, constructed with an internally annular milled surface or portion, b, in combination with the male die C, substantially as shown and described, whereby the watch-case front or back is not only struck up into form, but is milled on its border or rim, and formed with an internal ring-supporting shoulder, f.

187,851. WATCH-CHAIN BARS. WILLIAM S. HICKS, New York, N. Y.—Filed Jan. 26, 1877.

The tubular or hollow chain-bar A, provided at one end with an ornamental head, o, in combination with

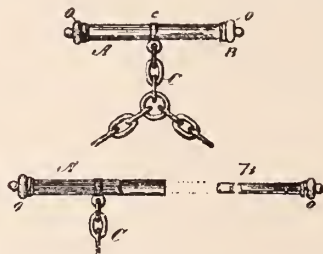

a detachable pencil-case, B, provided with a corresponding head, o', all constructed substantially as described, so that when the bar and pencil are united the whole shall have the appearance of a single solid bar.

Pittsburgh.

M. Bonn, of M. Bonn & Co., has gone east.

Leo Weil, who recently assigned, has decided to join the list of jobbers.

D. S. Pelton, Sistersville, W. Va., has sold out to N. L. Marsh, Bellaire, O.

Morris Baer, one of Ollendorf's travelers, will go into the jobbing business.

E. De Roy has returned from New York, where he purchased Spring stock.

C. S. Hauser will remove from Smithfield St. to Frankstown Ave., E. E.

G. A. Schlechter, Reading, Pa., is the manufacturer of the International League of Press Clubs' button.

Bernard Arons is receiving bids for the complete renovation of his store front, intending to begin operations April 1st.

Mr. Hering, who sold his property on Butler St., is negotiating for the sale of his stock and fixtures, intending to go to California on account of his health.

Traveling men in Pittsburgh the past week were: F. Platt, Foster & Bailey; M. Stratton, Jr., John W. Reddall & Co.; Alex. Patterson, Simons, Bro. & Co.; Arthur Bradshaw, Meriden Britannia Co.; M. Lambert, H. Zimmern & Co.; J. Adler, L. & J. Adler & Co.; Ed. Rogers, Parks Bros. & Rogers; W. C. Greene, W. C. Greene &

Co.; Mr. Matschke, Kuhn, Doerflinger & Co.; J. E. Simonson, A. J. Hedges & Co.; W. H. Bryant, T. G. Hawkes & Co.; Mr. Tinker, W. B. Durgin; Mr. Sylvia, Mt. Washington Glass Co.; G. A. Henckel, F. H. La Pierre; A. R. Huppen, Wm. S. Hedges & Co.; Chas. E. Dorr, Gorham Mfg. Co.; W. F. Corey, Corey & Osmun; Geo. D. Munson, Wm. Rogers Mfg. Co.; Wm. T. Gough, Carter, Sloan & Co.

A Motion in the Dueber Cases.

A motion will be made in the New York Supreme Court chambers to-day in the suit of the Dueber Watch Case Mfg. Co. against the manufacturers of watch cases and movements, asking that seven commissions issue to St. Louis, Cleveland, Philadelphia, Milwaukee, Chicago, Cincinnati and Boston, to take the testimony of certain jobbers, whom the plaintiffs claim are necessary witnesses in their suit. The jobbers named in the commission are:

St. Louis, Mo.—August Kurtzborn, Meyer Bauman, Edmund Achard and Morris Eisenstadt.

Cleveland, Ohio.—Russell E. Burdick, Lucius M. Sigler and John M. Chandler.

Philadelphia, Pa.—Julius Rosendale, August Dilsheimer, Samuel Kind, Frederick M. Simons, Abraham Sickels and Charles Hollinshed.

Milwaukee, Wis.—Christian Preusser.

Chicago, Ill.—Wm. M. Alister, Adolph Hirsch, Max C. Eppenstein, Simon Glickauf, Geo. Wilson Brethauer, Herman F. Hahn, Carl F. Happel, Leopold Sonnenschein, Chas. Henry Knights, Lemuel W. Flershem, Louis Manheimer, Maurice A. Mead, Maximilian Ellbogen, Benjamin Allen, Julius Schnering and G. W. Marquardt, Jr.

Cincinnati, O.—Wm. S. P. Oskamp, Charles H. Nolting, A. G. Schwab, Aaron Herman, Chas. J. Stern, Henry Habn, Samuel M. Seek, Jos. S. Voss, Aaron Plaut, Alfred Oskamp, Jno. E. Daller, Louis Gutman, C. J. T. Gutman and C. J. T. Bene.

Boston, Mass.—Eugene B. Floyd, David C. Percival, Austin Sylvester, Charles Harwood and Chas. F. Morrill.

Leyson, the jeweler, of Butte, Mon., pleasantly surprised the natives recently with his new electric sign. The sign contains the word "Leyson" with a border of lights all around it. The lights go out and light up again in all colors and shapes. It can be seen blocks away.

UMBRELLA STRAPS

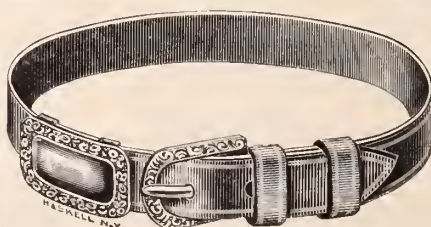

STERLING SILVER BUCKLES & SHIELD.

Send for Sample.

HENRY C. HASKELL Maker,

11 JOHN STREET, NEW YORK.



**Trade Gossip.**

Attention is again called to the Easter book marks offered by Queen & Co., 1010 Chestnut St., Philadelphia, Pa., on another page. The popularity of an Easter gift so appropriate as this, is sure to create large sales. Queen & Co. are filling orders promptly, but as the demand will be very great within the next few days, those who wish to show them and have enough to supply their trade, should order generously and promptly.

The following letter is another sample of the testimonials received from the trade by the publisher of Martin Brunor's book, *The Practical Electroplater*:

EMILE BRUNOR, ESQ.

DEAR SIR—Replying to yours of the 23d will state that while our knowledge in the line of coloring and its different branches has been sufficient to carry out our purposes, we must state there are a great many ideas in *The Practical Electroplater* that are new to us and think it would pay any manufacturer to have a copy in his possession. Thanking you for answers to our inquiries we are, Yours respectfully,

R. L. GRIFFITH & SON.

Among the prominent foreign houses who have subscribed for this work are Cristofle et Cie, the leading silver manufacturers of France.

Among the latest and most attractive conceptions in Easter spoons is the new egg and coffee spoon originated and manufactured by Daniel Low, the maker of "Witch" spoons, Salem, Mass. The design of the handle represents two chickens just coming from the eggs. The stem between this and the bowl contains the word, Easter. The die is very deeply cut, and thus the spoon is a heavy one, weighing about half an ounce. It is made with either silver or gold bowl, and is a very suitable Easter gift, and will undoubtedly have a large sale. An advantage accruing to the jeweler handling these goods resides in the fact that they will be extensively advertised by the maker in leading monthly magazines.

The first ball bearing wheel and ball bearing head polishing lathe ever offered at a price within the reach of every watchmaker was noticed the past week in the salesrooms of the Excelsior Sign & Mfg. Co., L. S. Grout, manager, at 56 State St., Chicago. The ball bearings reduce the friction to a minimum and are a great improvement over the old models. A raised rim to the square table is an addition that keeps the tools in place and will be appreciated. Packages in this factory ready for shipment included a Hugo countershaft, with new screws for adjusting the speed-wheel and pulleys, for Max Hartung, Chicago; large 36-inch carved iron watch sign, Louis XIV., for S. E. Sanborn; a twist bow English pendant watch sign, No. 50, and a huge pair of spectacles for Sommer & Pierik, Springfield, Ill.; an 18-inch Louis XIV. watch sign and one of Grout's improved ball bearing polishing lathes for E. E. Dubreuit, Anaconda, Mon., and an improved Columbia polishing lathe for A. Goldberg, Helena, Mon. As before remarked, trade is picking up in the west.

**The Trade's Forum.**

TIFFANY & CO.'S AWARDS.

NEW YORK, March 3, 1894.

Editor of THE JEWELERS' CIRCULAR:

On page 3 of the Silver Anniversary number, Feb. 7, 1894, I read with some interest the list of 47 awards granted to the Gorham Mfg. Co., by the World's Columbian Exposition, Chicago, 1893, showing, as they must, a remarkable scope and variety of work. But I was somewhat surprised to note the following item in connection with this advertisement. It reads as follows:—"containing a greater number of awards than given to any other single exhibit at the World's Fair."

Knowing that THE CIRCULAR always endeavors to furnish exact facts, and as this statement has not been corrected in the two succeeding numbers, the Gorham Mfg. Co. is evidently laboring under a misapprehension regarding the statement in question. I have, therefore, carefully gone over the facts, and herewith append a list of awards granted to the firm who have, for three successive Expositions, brought American silver to the high standard that it now occupies, so that it has received universal recognition.

In addition to this Messrs. Tiffany & Co. did not enter a single piece for competition that was designed by anyone else but their own personnel, and did not exhibit anything that had ever been either in their stock or shown at any former exhibition. Even the ten historic prize cups and vases made by them were not entered for competition as they were not made for the Exposition, or they would have been entitled to other awards.

Therefore, with your permission, Mr. Editor, I herewith append the list of 57 awards granted to Messrs. Tiffany & Co. by the World's Columbian Exposition. Awards received from the Anthropological and one or two other departments have not yet been definitely heard from.

I not only append the names of the awards, but also the names of the judges, many of whom were eminent men, and the classes and groups in which the exhibits were entered.

I trust that this correction will be taken in the spirit of justice in which it is meant by

VERITAS.

AWARDS GRANTED TO MESSRS. TIFFANY & CO. BY THE WORLD'S COLUMBIAN EXPOSITION.

LIBERAL ARTS.—GROUP 158.

Medals struck from a die cut by Tiffany & Co., D. P. Secor, Judge.

FISHERIES.—GROUP 40.

Pearls: Oriental and American Pearl Collection, Sea and Fresh Water Pearl Shells, Pearls Artistically Mounted in Jewelry, Silverware, Leatherwork, etc., Dr. T. A. Henshall, Judge.

MINES AND MINING.—GROUP 42.

Fine Minerals, Gems and Precious Stones, Prof. George H. Williams, Judge.

GROUP 56.

Collection, Illustrating the Savings of Gold and Silver in Jewelry Shops, Mr. G. E. Bailey, Judge.

GROUP 66.

Collection, Exhibit of Gold and Silver Alloys, C. Sellerier, Judge.

GROUP 89.

Fine Stationery, Writing Paper, Cards, A. Amano, Judge, Japan.

GROUP 93.

Niello Work, Prof. Rein, Judge, Berlin, Germany; Champ Leve Enamels, Prince S. Wolkonsky, Judge, Russia.

GROUP 96.

Glass, sculptured, engraved, mounted in silver, C. Colne, Judge, United States. Metal carvings, chiseling in gold and silver, Dr. R. Otto, Judge, Germany. Ornamental, carved and stained ivory, C. Colne, Judge, United States.

GROUP 97.

Silver table ware, plates, salvers, candelabra, gold and silver ware, gilt ware for table decoration, knives, forks and spoons, fancy articles, silver spoons, cane heads, Marquis E. Ungaro, Judge, Italy. Mixed metals, mokumi inlaid enameled, T. Hayashi, Judge, Japan. Plated ware on hard nickel, silver base, Goodman King, Judge, United States. Damascening of gold and silver on iron, Madame Dupuy de Lome, Judge, Spain. Etchings on decarbonized steel, E. Crawford, Judge, Great Britain.

GROUP 98.

Gold ornaments, rings, chains, bracelets, necklaces, Chevalier G. Grant, Judge, Italy. Diamonds, J. D. Yerrington, Judge, United States. Colored gems, rubies, sapphires, fancy stones, Dr. A. C. Hamlin, Judge, United States. Diamond cutting, J. D. Yerrington, Judge, United States. Rubies and fancy stones, (cutting), Dr. A. C. Hamlin, Judge, United States. Agate, rock crystal, jade, Robert D. Williams, Judge, United States.

GROUP 99.

Watch cases, clocks, G. M. Rouge, Judge, Switzerland. Astronomical timekeepers, C. E. Tissot, Judge, Switzerland.

GROUP 108.

Canes, A. D. Grinevsky, Judge, Russia. Fancy bags; pouches, card cases, portfolio, silverware and jewelry cases, valises, dress-suit cases, hand bags, toilet articles; collections, leather of animals, birds, reptiles, fishes, C. R. Soustchevsky, Judge, Russia.

MR. HEYDT REPUDIATES AN INTERVIEW.

NEW YORK, Feb. 21, 1894.

Editor of THE JEWELERS' CIRCULAR:

In THE CIRCULAR of to-day I am quoted as expressing some views regarding advertising, reprinted from the *Advertiser's Review*.

If such a publication exists it is news to me. I have never seen a copy of it, or been interviewed by a representative of the paper, and as the views expressed are unworthy of Tiffany & Co., and that regarding the value of magazine advertising particularly entirely contrary to my convictions, I would beg the privilege of repudiating the interview.

Very truly yours,

GEO. FREDERIC HEYDT.

**WILLIAM H. ATWATER,**  
SUPERIOR CLOCKS,  
IMPORTED AND DOMESTIC,  
NO. 10 MAIDEN LANE,  
NEW YORK.

SOLE REPRESENTATIVE,  
FD. & CHAS. PIERRE & CO.,  
PARIS.



**Detached Pendulum Escapement With Constant Force.**

FERD. BAGINSKI, in *Deutsche Uhrmacher Zeitung*.

A LARGE part of the influences that make the rate of a pendulum clock variable, is due to the altering force of the impulsion upon the pendulum, best observed in clocks with spring force, which are apt to vary noticeably with the state of the tension of the spring. Beside this, the increased friction to be found in all clocks where the oil becomes thick also interferes largely with the rate of the time-piece. Led by these and other considerations the inventor

same staff *b* with the levers *h* and *c*, is sketched as being pushed to one side, because in its actual position it is covered by the plate *P* and the levers *h* and *g*, so that it could not be distinguished in the illustration. The examiner must therefore imagine the lever *v*, together with the unlocking finger *y* as being located upon the staff *b* of the two levers *h* and *c*, behind the plate *P*. The pendulum rod *h* and the crutch *x* are sketched as being shorter than they really are for the sake of saving space.

The impulse upon the pendulum, independent from the propelling force of the running work, is effected by the proper weight of the levers *v*, *c*, *h* and *z*, which remains constant in the following manner: The lever *v* lies with its end upon the pin *w*<sup>1</sup> of the lever *w*. Upon the latter again lies the pin *s*<sup>1</sup>, which is located on a vertical arm *s*, standing in connection with the levers *z*, *h* and *c*. Since now, the lever *w* is located upon the same staff *w*<sup>2</sup>, which also carries the pendulum crutch *x*, the pendulum *h* receives at each oscillation from left to right, an impulse in the shape of the pressure, exerted by the levers *v*, *c*, *h* and *z* by their proper weight, by means of the lever *w*. The return journey of the pendulum from right to left is perfectly detached.

Let us suppose, in the illustration, the pendulum *h* swings to the right. Hereby the lever *w* with its pin inclines downward, the lever *v* with the unlocking finger *y* still follows this descent, operating with the same weight upon the pin *w*<sup>1</sup>, also the levers *h* and *z* up to the point where the farther descent of the lever *h* is limited by the pin *l* in the plate *P*. At this moment, the lever *z* lays itself upon the lever *h*. This laying upon is permitted to the lever *z* only by the circumstance that the lever *h*, shortly before the movement in which the pendulum *h* reaches the limit of its oscillation to the right, becomes locked, as previously mentioned, upon the pin *l*. This state of locking is immediately thereafter shared by the lever *v*, fixed upon the same staff *b*, but not the unlocking finger *y*; because after the levers *h* and *v* have assumed a locking position, the pendulum *h* still swings a little to the right, and the lever *w* with its pin *w*<sup>1</sup> thereby descends also a little more. This latter short descent, now, is shared in only by the unlocking finger *y*, because it is located upon the lever *v* easily movable, by means of the screw *y*<sup>2</sup>, and because the pin *s*<sup>1</sup> in the arm *s* lays itself upon the upper edge of the unlocking finger *y* and thereby presses with its proper weight and the weight of the lever *z* the unlocking finger downward. The vertical arm *s* is firmly connected with the lever *z*, but has a re-

volving motion around the point *h*<sup>1</sup>. The descent of the unlocking finger *y* alone, now permits the lever *z* to lay itself upon the lever *h*. So as to limit the single up and down motion of the unlocking finger *z*, there is about in the middle of the lever *v* the pin *v*<sup>1</sup>, which projects into into the slot *y*<sup>3</sup> of the unlocking finger *y*. This slot *y*<sup>3</sup> lays itself with its upper or lower face on the pin *v*<sup>1</sup>. The lever *c*, of one piece with the lever *h*, is by a jointed piece *d* connected with the unlocking arm *r*, on which is located the locking pallet *o*, upon the later operate the locking teeth, enumerated with 1, 2, 2, etc, of the escape wheel *u*. Each of these teeth carries a small pin which acts at first upon the locking plate *z*<sup>3</sup> on the lever *z*. Beside this, the escape wheel *u* has still a second tooth rim, the teeth *m*<sup>1</sup> *m*<sup>2</sup>, of which act alternately upon the inclined plane *h*<sup>2</sup> of the lever *h*.

While the lever *h* goes downward, the lever *c* follows it; while this moves a little sideward to the left, it draws at the same time the lower end of the locking arm *r* a little to the left. Since, now, the locking pallet *o* is located stationary upon the arm *r*, it evades thereby the locking tooth 2 to the left, and liberates it. The escape wheel *u*, impelled by the force of the mainspring or weight, now passes forward in the direction of the arrow. During this former motion, the lever *z* has, as before mentioned, laid itself upon the lever *h*, whereby the locking plane *z*<sup>3</sup> receives the pin in the locking tooth 5, and for the present prevents the escape wheel *u* to proceed.

When, now, the pendulum *h* has accomplished its oscillation to the right, and starts on its journey to the left, the pin *w*<sup>1</sup> in the lever *w* seizes the lower edge of the unlocking finger *y*, raises it a little, and thereby also the pin *s*<sup>1</sup> in the arm *s*. By this the locking projection *z*<sup>2</sup> is raised a little at the same time and permits the pin in the locking tooth 5 to slide from the locking plane *z*<sup>3</sup> upon the lifting plane *z*<sup>1</sup>. The impelling force operating upon the escape wheel becomes effective thereby, sets it in motion, and the pin sliding underneath the lifting plane *z*<sup>1</sup> raises the lever *z* upward. Hereby the tooth *m*, with the aid of the inclined plane *h*<sup>2</sup>, pushes also the lever *h* upward, so that the escapement parts finally find themselves again in the locking position shown in the illustration, with the single difference that the escape wheel *u* has advanced one tooth forward.

While the levers *h* and *z* are in the above described manner raised by the escape wheel, the lever *c* moves a little to the right, whereby the locking pallet *o* assumes such a position that the next following locking tooth 1 can lay itself on the former. At the same time the pendulum *h* continues freely onward to the left, while all the parts are in a locked condition from the moment when the locking tooth 1 has fallen upon the pallet *o*. During this oscillation to the left, however, the pendulum stands already under the pressure which the levers *v*, *c*, *h* and *z* exert by their weight upon the pin *w*, and thereby upon the crutch *x*, and by this pressure the pendulum again receives an impulse to the right.

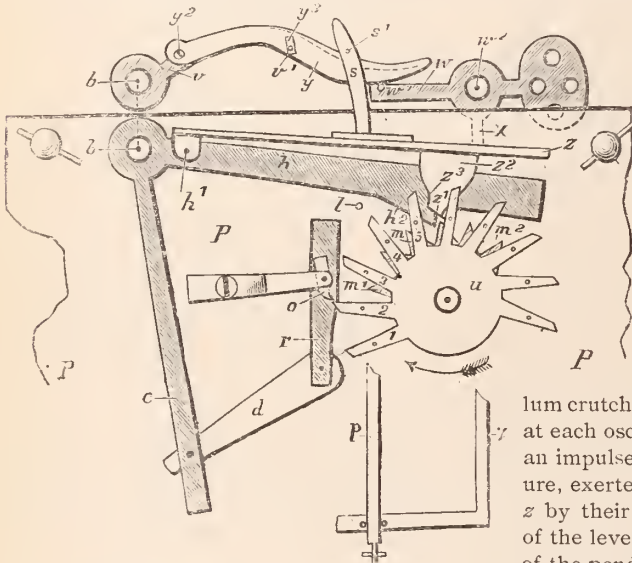

of the detached pendulum escapement with constant force to be described in the following, enthusiastically exclaims that the future belongs to such time-pieces, and adds "swayed by these considerations I have endeavored to construct a clock of this kind, for which I received a patent recently." The accompanying sketch is the escapement constructed by him, and he sought to produce pendulum oscillations as detached as possible, ever keeping in view the circumstance to make the entire mechanism as simple as possible.

The illustration shows the escapement in a locking condition. For the sake of plainness, the large bridge, in which run the front pivots of the staff *b* and of the escape wheel *u* running before the plate, are omitted; beside this, the lever *v* upon the

**FOR JEWELERS' USE.**

G. A. Kleemann's Patent Improved Student Lamp.

G. A. Trade Mark.

**THE GERMAN AMERICAN.**

It preserves all the improvements which have made the St. Germain Student Lamp so acceptable to Watch-makers and Mechanical Jewelers, but is a much larger Lamp, fitted with a nine inch shade and its new large burner—far superior to that of the St. Germain—gives a light nearly double in brilliancy.

Steady white light, perfect combustion, without much heat, safe against explosion.

Will last a lifetime. Wick easily adjusted. Illustrated circular free.

**HINRICHS & CO.,**  
29, 31 & 33 PARK PLACE,  
NEW YORK CITY.

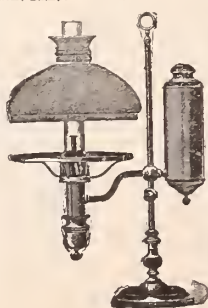





# RUDOLSTADT

## ART POTTERY

CONTAINS all the elements required as to designs, decorations and workmanship, in a high grade of Art Goods adapted to the Jewelry Trade, and yields a larger margin of profit than any other class of Pottery.



### L. Straus & Sons,

SOLE AGENTS,  
42-44-46-48 Warren Street,  
116 Chambers Street,  
NEW YORK.

### Rich Cut Glass

AND

### DECORATED ART WARES.



### Mt. Washington Glass Co.,

### New Bedford, Mass.

RICH DISPLAY OF GOODS AT

### New York Store: 46 Murray St.

When you visit Chicago do not fail to inspect our full line of goods at the new store of Pairpoint Mfg. Co., 224 Wabash Avenue.

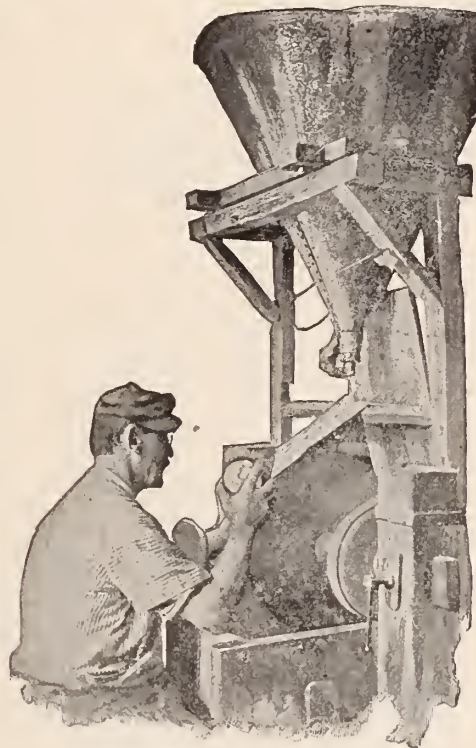

GLASS CUTTER AT WORK.



### M. L. READ & CO.,

161 DORRANCE ST.,  
PROVIDENCE, R. I.

THE  
Old  
Reliable  
House

FOR  
STICK PINS AND  
WHITE STONE GOODS



AMERICAN RAILWAY SUPPLY CO.  
24 Park Place, NEW YORK.

## DAMASCUS

Made in a full line. The Best Pattern of the Season. Ready this Season. A general line of Hollow Ware. New Ideas Constantly.



DAMASCUS TEA.



### F. M. WHITING & CO.,

Manufacturers of STERLING SILVERWARE, Novelties in Silver Jewelry.

NORTH ATTLEBORO, MASS.



# FERDINAND BING & Co.,

106 GRAND ST., N. Y.

❁ ————— NEW DESIGNS IN ————— ❁

China Clocks and Gilt Bronze Sets, Fine Painted Dresden Goods in  
Vases, Cups and Saucers, and Plates; Cararra Marble Statuary,  
French Cabinets and other Fancy Furniture.

OPPENHEIMER BROS. & VEITH,  
WATCHES AND

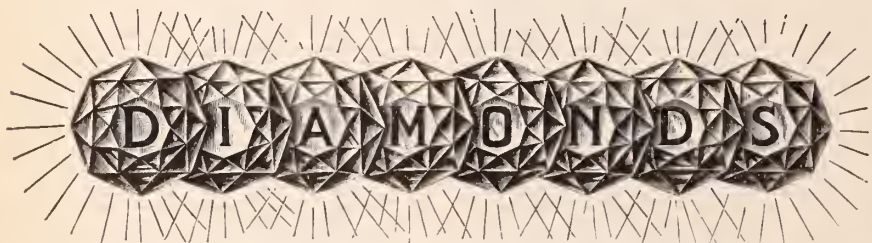

DUEBER CASES. HAMPDEN MOVEMENTS.

AMSTERDAM, HOLLAND, 2 TULPSTRAAT.

LONDON, ENG., 28 HOLBORN VIADUCT.

NEW YORK, 35 MAIDEN LANE.

WOOD & HUGHES,  
STERLING SILVERWARE MANUFACTURERS

New York Agents for the Derby Silver Co.'s

FINE QUADRUPLE PLATED WARE,  
No. 16 JOHN STREET, NEW YORK.

206 Kearney St., San Francisco, Cal.

HASKELL & MUEGGE, Agents.

Jules Jürgensen

OF COPENHAGEN.

*The reputation these watches have maintained for  
Fifty Years has never been equalled, being made  
on strictly scientific principles and no expense spared to  
give the Best results in mechanism and timekeeping  
qualities.*

SOLE AGENTS,

John C. Hyde's Sons,

NO. 22 MAIDEN LANE.

OUR IMPORT LINES OF

China, Glass AND Bric-a-Brac

....., ARE COMPLETE .....

WE CALL PARTICULAR ATTENTION TO THE FOLLOWING SPECIALTIES:

LIMOGES CHINA AND SAXONIA WARE, ROYAL DRESDEN CHINA,  
SEVRES PORCELAIN, PARIS NOVELTIES, VIENNA CROWN  
WARE, ROYAL BONN & DELFT FAIENCE,  
AUSTRIAN GILT GLASS.

## CHARLES AHRENFELDT & SON,

50, 52 & 54 Murray Street, New York.





**Exquisite Bric-à-brac at Geo. Borgfeldt & Co.'s.**

SOME of the most artistic work ever shown by Geo. Borgfeldt & Co., 18 Washington Place, New York, may be seen in the small figures and groups in the Russian, French and Viennese bronzes displayed in their art pottery and bric-à-brac department. So perfect is the detail and so beautiful the execution in these exquisite subjects, that to attempt by description to give any adequate idea of their artistic merit would prove vain; however, the accompanying illustration may serve to convey a fair impression of the beauties of a few of the smaller pieces of the Viennese bronzes.

about 15 inches, and like the smaller figures on either side, rests upon an onyx jewel casket with cloisonné effects. The pieces on the right and left are also of Vienna bronze and represent Arabian and Oriental scenes and subjects in natural colors.

**New Lines in Pointon Ware.**

POINTON & CO., Limited, Stoke-on-Trent, England, have prepared an unusually large display of novelties for the Spring trade; the "paper-white" nature of their china body is well maintained. We noted some very fine pierced dessert plates and the "Victoria," with raised gold ornament and faintly tinted flowers attract attention. We think that the "Gem" plate, with richly gilt ornamental border, both in raised work and flat gilding, will find a place in many dealers' eyes; the painting of the musical trophies on the set is commendable. The "Princess" shape is one that will find a ready sale. We admire the pansy decoration, treated naturally and re-



A GROUP OF EXQUISITE BRONZES AND SMALL CLOCKS SHOWN BY GEO. BORGFELDT & CO.

The subject of the centerpiece, "Crucify Him," will no doubt at once be recognized, as it is an exact copy of one of the most prominent figures in the famous painting of "Christ Before Pilate." This piece stands

Those descriptive of Arab life particularly are most interesting subjects and are thoroughly true to nature. At the front is an assortment of small enameled Vienna bijou clocks, with rococo frames.

lieved with raised gold. Fruit dishes, which Messrs. Pointon have lately made a specialité for the American market, were to be seen in great numbers. The "Rococco" is a good shape.—*Pottery Gazette*, London.



**The Connoisseur.**

(Continued from page 39.)

**The Rambler's Notes.**

WHAT THE RAMBLER SAW AND HEARD AMONG THE DEALERS IN ART POTTERY, CUT GLASS, BRONZES, ETC.

THE BEAUTIES OF THE RENAISSANCE SHAPE. A NEW style in the Vienna china shown by P. H. Leonard, 76 Reade St., New York, is the Renaissance, a shape singularly attractive and out of the general line of former styles. In this style the prevailing floral decoration, violet, is to be seen in many combinations upon a full line of table, boudoir, desk and cabinet novelties. The Renaissance is ornamented with many other floral decorations and is also shown in the plain white with gold on the border. Among the newest pieces introduced in table novelties are spoon trays, which like the boudoir sets, pin, pen and brush and comb trays, sugars and creams, etc., are shown in various decorations.

NEW LINES IN GUERIN PORCELAIN. A HANDSOME and varied assortment of fish, game, after dinner, chocolate, tête-à-tête, ice cream and other sets has lately arrived at the warehouses of Chas. Streiff, 31 Barclay St., the New York agent for the white and decorated

china of Wm. Guerin & Co., Limoges, France. A novel design shown in fish and game sets is a water effect, representing foam or the spray of the sea. The shape on which this is shown, the "Beaufort," is also new. In tête-à-tête sets is a pretty decoration of turquoise blue with panels of flower paintings outlined in gold. Scenery and flowers are to be seen on an attractive leaf shaped chocolate set shown in many new designs with incusted borders. Mention should also be made of the large assortment of hand painted plates in the Empire style, many of which have borders of openwork of *bleu de four*. The latest plate shown is the "Argent," an artistic and attractive shape with the border of incusted gold and its center either plain or ornamented by a gold monogram.

NEW LINES IN CUT GLASS.

LAZARUS, ROSENFELD & LEHMAN, 60 Murray St., New York, are showing an entirely new line of cut glass specialties in shapes which they exclusively control. Their assortment of cut glass is the largest and richest they have ever carried. The principal cuttings, the strawberry, diamond, and fan and the Kensington, are shown on various sized berry bowls, rose bowls, celery trays, suzar sifters, oil and vinegar bottles, decanters, claret jugs, spoon holders, Roman punch glasses, and bouquet and violet holders, as well as the regular line of

staple pieces. They have also a variety of smaller articles with silver tops, such as pepper and salt shakers, mustard pots, etc.

NEW STYLES IN

PORCELENE CLOCKS. TWO new styles of Porcelene mantle clocks have been introduced by the F. Kroeber Clock Co., and may be seen at their main store, 360 Broadway, New York. In size they are a medium between the small alarm and the large mantel clocks, and are fitted with one-day movements. The colors are the same as in the former styles.

TO BETTER DISPLAY THEIR FINE LINES.

EACH year sees Union Square, New York, more firmly established as a wholesale district for the lines entering into the jewelry and kindred trades. Among other removals to that vicinity the coming May will be that of the New York warerooms of T. B. Clark & Co., now at 53 Park Place. After May 1st this firm will occupy quarters on the third floor of 860 Broadway, corner 17th St., where they will have better facilities than ever before for showing to advantage their large assortment of rich and brilliant cuttings.

THE RAMBLER.

A small heart shaped Queen Anne tray, holding a complete tea equipage in silver, is intended for some petted child of the very rich.

**Paul Jeanne,** EIGHTEENTH STREET and 4<sup>TH</sup> AVE., N. Y. (Bradley Building.)

MANUFACTURER OF

≡ FINE DIAMOND JEWELRY. ≡

WM. SMITH & CO.,

Manufacturers of Gold, Silver and Roll Plate Chains and Jewelry.



Novelties in Gold and Silver Bead Necklaces and Bracelets. Also a large line of Chain Trimmings and Silver Rings.

Office: 5 and 7 Maiden Lane, New York.      Manufacturing: 61 Peck Street, Providence, R. I.

**Three Great Successes.**  
 Our Industrial School of Optics Practical  
 Our Swell Gold Construction Progressive  
 Our Prescription Department Punctual  
**ASSURED SUCCESS TO YOU**  
 If you take the Practical course in refraction, sell The Swell End Eyewire Gold Spectacles and Eye Glasses, and send your Prescription work to our special department which you will find accurate and punctual.  
 Avoid delay and errors by keeping in mind the old reliable  
**Spencer Optical M'f g Co.**  
 15 MAIDEN LANE, NEW YORK.

**The "Bryant" Rings.**

Are widely advertised and will sell when anything will, therefore every Retail Jeweler should buy them.

IF NOT CALLED UPON BY OUR TRAVELERS ORDER DIRECT FROM

M. B. BRYANT & CO., - 10 MAIDEN LANE, N. Y.

OLDEST RING MAKERS IN AMERICA.

2 DIAMONDS - 823  
 TURQUOISE & PEARLS - 800  
 MARQUISE - 815  
 TURQUOISE & PEARLS  
 913  
 920  
 764





ART GOODS AND SPECIALTIES ♦

FOR JEWELERS and ART DEALERS.

WE ARE EXHIBITING THE HIGHEST GRADE OF *ART GOODS* IN *FINE POTTERY, CLOCKS, BRONZES, MARBLE, ONYX, VENETIAN, FRENCH AND DRESDEN FURNITURE, GLASSWARE, CLOISONNE, FAIENCE, BISQUE, ETC., ETC.*, AND BEAUTIFUL COLLECTIONS OF THE MOST CELEBRATED MAKES IN *FINE PORCELAINS*.

WE HOPE EVERY BUYER WILL RECOGNIZE THE IMPORTANCE OF SEEING THESE REPRESENTATIVE LINES BEFORE PLACING ORDERS, AND MAKE US AN EARLY VISIT.

**GEO. BORGFELDT & CO.,**

18, 20, 22 WASHINGTON PLACE, Cor. Greene St.,

**NEW YORK.**



**An Abuse to be Corrected.**

OUR attention has been called to a matter which merits the strongest reprobation among all honorable manufacturers. In recent numbers of watchmakers' trade journals we find advertisements representing boldly and unblushingly that certain goods are fac-similes and imitations of articles which have won deserved renown by their known and acknowledged merits. We copy the following statements as to slide rests: "Will interchange with standard American lathes," "Size of and accurately interchanging with the Webster-Whitcomb lathes," "Locle slide rests for the Moseley lathe," "Will interchange with the Whitcomb lathe," also advertisements like this: "Imitation of the Webster-Whitcomb lathe," "Fac-simile of the Whitcomb No. 1 1/2 lathe," "Manhattan foot wheel, the same as the Webster foot wheel."

To any fair minded man we think such statements will appear in the strongest degree unfair and dishonorable. More than this, many of the cuts used to advertise these imitations appear to be genuine cuts of the genuine articles with the original names cut out and the electrotype dressed up to cover the deceit. There is not an hon-

est manufacturer in any line of goods in the country who is not interested in this subject. The American Watch Tool Co., of this city, and the Moseley Co., of Elgin, as well as other reputable manufacturers have won public confidence in their goods by years of hard work, by thousands of dollars expense and by honest, square dealing with their patrons. Not only are they liable to suffer financial loss in a decreased demand for their products but the reputation they have won also suffers from the imperfect work commonly done by imitation tools and attachments palmed off on purchasers either as the genuine articles or as equally good.

Such schemes we believe are frauds on the face of them and they should be denounced by all men who have reputations won by honest effort, which cannot fail to be damaged by a continuance of the methods of which we have written. We believe there is a law to protect the manufacturer from such annoyances and that it can be successfully invoked.—*Free Press, Waltham, Mass.*

**TRANSFER AND ADAPTATION OF OLD DESIGNS ON WATCH CASES.**

While the mere transfer of an old form existing upon something else to a watch case is not patentable invention, yet a patent for a watch case design is not invalidated by the pre-existence upon something else of all the elements of the design, but arranged and combined in a different manner, resulting in a materially different appearance.

*Untermeyer v. Freund, Circuit Court of Appeals. Second Circuit.*

**The Other Side of Life.**

MARY—Do you believe it is possible for a girl to be so homely as to stop a clock?

JANE—I don't know. You can easily find out, however.—*Boston Transcript.*

**AN OCCUPATION.**

POLICE MAGISTRATE—What do you do for a living?

"Pick up diamond bracelets around the streets, Your Honor."

"Thirty days."

"Thank you."—*New York Herald.*

**NOT UP TO DATE.**

GEORGE—It's all very well for Miss Prout to join the ladies' reform association, but why does she wear goggles?

HIS WIFE—How little you know about reform, George. The members think the naked eye is immodest.—*Judge.*

**OUT OF HIS MIND.**

JUDGE (to prisoner)—You are found guilty of meeting the plaintiff in a lonely street, knocking him down and robbing him of everything except a valuable gold watch which he had with him. What have you to say?

PRISONER—Had he a gold watch with him at the time?

"Certainly."

"Then I put in a plea of insanity."—*Texas Siftings.*

**ALBERT BERGER & CO**  
47 MAIDEN LANE, N. Y.  
**Spectacles & Optical Goods,**  
GROUND LENSES A SPECIALTY.

**Welded Chrome Steel and Iron**



FOR BUILDING

Jewelers' Safes, Vaults, Etc.

Positively BURGLAR PROOF, cannot be Cut, Sawed or Drilled.

WE are the only manufacturers of Chrome Steel in the United States. None genuine unless stamped with our Trade Mark.

**CHROME STEEL WORKS,**

KENT AVENUE, KEAP AND HOOPER STREETS, BROOKLYN, N. Y.



**J. R. WOOD & SONS,**  
14 JOHN STREET, NEW YORK.



**PLAIN SOLID GOLD RINGS.**  
**SEAMLESS PLAIN SOLID GOLD RINGS.**  
**ENGRAVED AND CHILD'S RINGS.**

No Ring Stamped Different from Quality. Send for Catalogue and Price List.

Old Gold and Silver received and estimated on; if amount allowed does not give satisfaction, notify at once and will return at our expense, in same condition as received.

**R., L. & M. Friedlander,**



IMPORTERS OF  
**DIAMONDS.**

WHOLESALE  
**JEWELERS.**

JOBBERS IN  
**American Watches.**

Tools, Materials, and Optical Goods.

Send for Catalogue.

65 & 67 Nassau Street, New York.



# HINRICHS & CO.,

29 AND 31 PARK PLACE,  
NEW YORK.

## BRIC-A-BRAC and ART POTTERY.

Doulton, Worcester, Royal Vienna, Teplitz, Dresden, Sevres, Coalport, Austrian Faience, Bisque Figures and Candelabras.

BOHEMIAN AND FRENCH CHRYSANTHEMUM VASES and Bouquet Holders, Atomizers, Cologne Bottles and Jewel Boxes.



### SPECIALTIES IN LIMOGES CHINA.

A. D. Cups and Saucers, Chocolate Cups, Teas and Coffees, Mustache Cups, designs and decorations entirely new and exclusively our own.

OUR SPRING STOCK was never more complete than now, and we never had a finer line of goods. Catalogues and Price Lists on application.

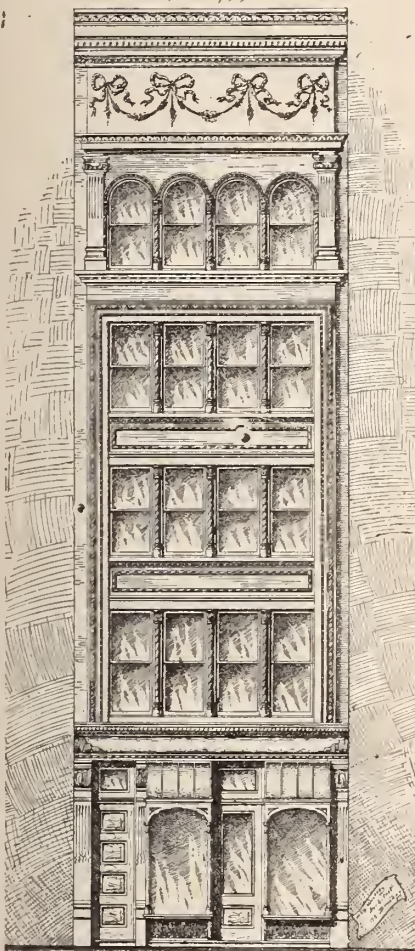

## OFFICES TO LET

BRIGHT AND CHEERFUL,

IN THE

HANDSOME NEW OFFICE BUILDING

45 MAIDEN LANE,

with elevator, steam heat, electric light, best of plumbing and all modern conveniences, at rentals from \$350 up. For further particulars, apply to

E. A. Cruikshank & Co.,

176 BROADWAY N. Y.



Elk, Shrine and Masonic Emblems a Specialty.

Badges of Every Known Order.

G. A. SCHLECHTER,

Manufacturing Jeweler.

READING, PA

### For BADGES AND MEDALS,

Flag Pins, Class Pins, Class Rings and Special Work of all Descriptions,

SEND TO E. R. STOCKWELL, MANUF'R.

19 John Street,

New York.

**"TIME IS MONEY"**  
 SEND YOUR PRESCRIPTIONS AND REPAIR WORK WHERE IT IS DONE ACCURATELY WITHOUT DELAY.  
**E. KIRSTEIN'S SONS CO.**  
 SEND FOR CATALOGUE. ROCHESTER, N.Y.

## "Old English"

Goffee Spoon.

\*\*\*



DESIGN PATENTED.

Towle Mfg. Co.,

MANUFACTURERS OF

STERLING SILVERWARE.

NEWBURYPORT: No. 214 Merrimack St. CHICAGO: Nos. 149 & 151 State St.

ESTABLISHED 1870.

## J. L. CLARK,

SWEEP SMELTER AND REFINER OF GOLD AND SILVER.

Buys every kind of Gold and Silverware, Jewelry, Watches and Platinum. Full market value paid.

No. 724 Filbert Street, Philadelphia, Pa.

SEND BY EXPRESS or Registered Mail. If my price is not satisfactory, I will return all articles.

## LIST REDUCED.

FOR 60 DAYS ONLY,

And STRICTLY for Cash With Order.

The List of the

## FRANCIS ENGRAVING MACHINE

Has been in some respects greatly reduced.

The Plain Bench Machine Reduced from \$75 to \$50.

For further particulars write to your Jobber or to the Manufacturer,

A. E. FRANCIS,

780 Cedar Avenue, Cleveland, Ohio.

February 15, 1894.

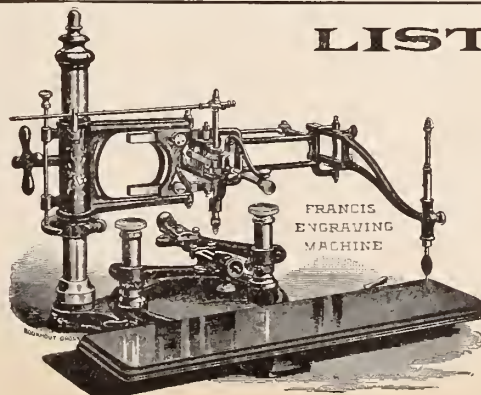





# Sapphires.

**M. D. ROTHSCHILD,**

NEW YORK: 41 & 43 MAIDEN LANE

LONDON: 15 HOLBORN VIADUCT

PARIS: 58 RUE LAFFITTE.

## S. F. MYERS & CO.,

WHOLESALE JEWELERS,

MYERS BUILDINGS, - - NEW YORK.

1894 ISSUE, No. 38,

### OUR ROYAL CATALOGUE

Illustrates all that is new, unique and desirable in everything that pertains to jewelry.

Sent free to dealers who have not received it.

TWENTY-TWO DEPARTMENTS.

SEVEN DOUBLE FLOORS.

Myers Buildings, 48-50 Maiden Lane, New York.  
33-35 Liberty St.,

## S. P. HOWARD,

Gold and Silver Assayer.

**Refiner and Sweep Smelter,**

33 MAIDEN LANE, NEW YORK.

Smelting and Refining Works,

28 & 30 Cumberland Street, Brooklyn, N. Y.

Specialties: Sweepings, Gold, Silver and Platinum.

FANCY DIALS TO FIT AMERICAN WATCHES.  
\$6.00 per doz. IN FLAT SECONDS.  
\$7.20 per doz. IN PRESSED SECONDS

Jobbers, Importers and Retailers generally, will be rebated by sending to us any Dials of our make which they may have on hand.

O'HARA WALTHAM DIAL CO., Waltham, Mass.

### Headquarters

FOR  
ELECTRIC & PORTABLE  
Watchman's Clocks

Lowest Prices.  
Latest Improvements,  
Patents 1886-1893.  
Send for Circular.

E. O. HAUSBURG,  
41 Maiden Lane, New York.

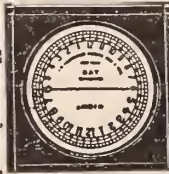

Price,  
Complete  
\$10.00



THE "ALERT."

# RUBIES.

E. KIPLING,

182 Broadway, New York.

ELEVATOR ENTRANCE, 2 JOHN ST.

FRENCH ENGLISH  
CLOCKS AND HALL CLOCKS AND  
MATERIALS. MATERIALS  
**CHAS. JACQUES CLOCK CO.,** 22 CORTLANDT ST., N. Y.

## L. LELONG & BRO.,

GOLD AND SILVER

**Refiners, Assayers AND Sweep Smelters,**

◁ SOUTHWEST CORNER HALSEY AND MARSHALL STREETS, ▷

**NEWARK, N. J.**

**SWEEPINGS A SPECIALTY.**

## J. SCHAWEL & CO., 29 John St., N. Y

GOLD & SILVER REFINERS, ASSAYERS & SWEEP SMELTERS.

STERLING SILVER, 925/1000 FINE IN SHEET AND WIRE.

Soft Platinum, Sheet and Wire for Manufacturing Jewelers.



## AMERICAN WATCH CASE CO.,

MANUFACTURERS OF GOLD CASES,

11 JOHN STREET, NEW YORK.

## WM. BIRMINGHAM & CO.,

MANUFACTURERS OF

All Kinds of Leather Spectacle and Eye Glass

**CASES,**

728 Arch Street, PHILADELPHIA, PA.

## J. PRINCE,

Jewelry Auctioneer,

At liberty from January 1st, 1894. Retail  
Jewelers only. Address,

Rooms 9 & 10, 137 BROADWAY  
N. Y. CITY.

# ALBERT LORSCH & Co.,

37 MAIDEN LANE, NEW YORK.

Branch, 167 Weybosset Street, Providence, R. I.

IMPORTERS OF DIAMONDS,

Rose Diamonds, Rubies, Sapphires, Emeralds, Opals, Moonstones,

Fancy and Imitation Stones, Novelties.

SOLE OWNERS AND IMPORTERS OF

*The Sumatra Gem.*

REGD. UNEQUALLED IN  
BRILLIANCY AND  
HARDNESS

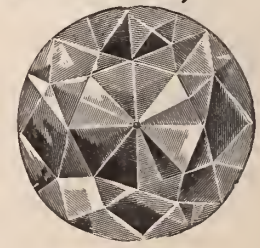
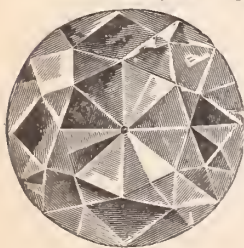

HIGHEST AWARD AT THE COLUMBIAN EXPOSITION, CHICAGO. 1893.

IT PAYS TO KEEP IN TOUCH WITH TRADE AFFAIRS. THE JEWELERS CIRCULAR For 4c a Week will do it. **Subscribe.**

1869=1894=Twenty-five Years, Oldest, Best, Brightest, Newest, =The Jewelers' Circular.



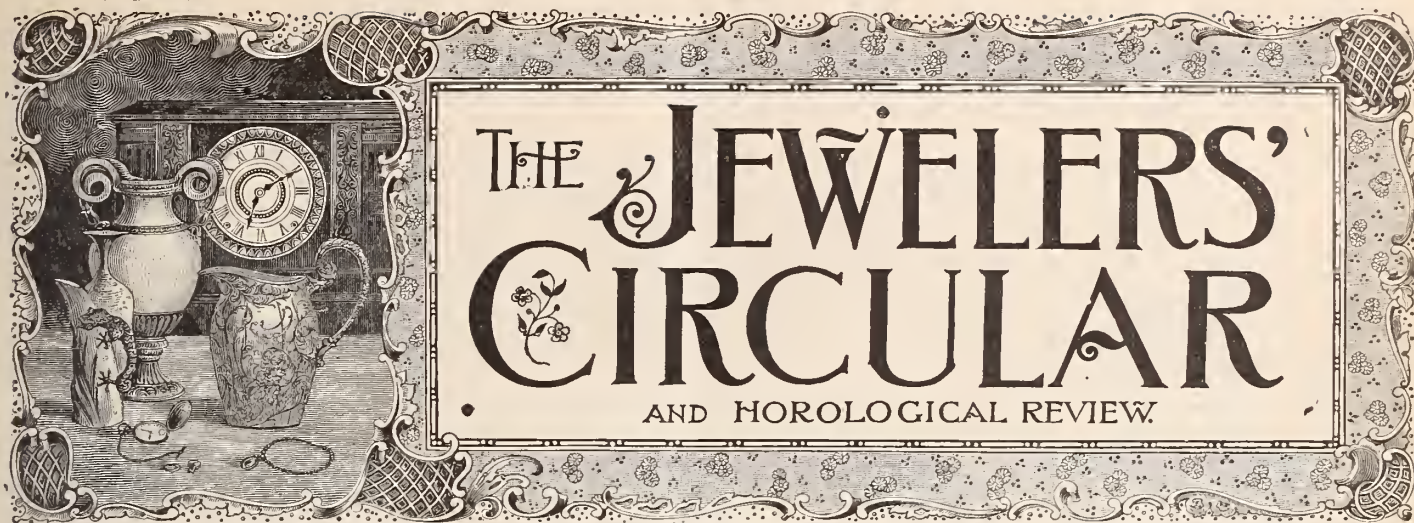

Copyright by THE JEWELERS' CIRCULAR PUB. Co.

189 Broadway, New York.

Entered at the Post Office in N. Y. as second-class matter.

VOL. XXVIII.

NEW YORK, WEDNESDAY, MARCH 14, 1894.

No. 6.

### CHARACTERISTICS OF RUSSIAN GOLDSMITHS' ART.

IN tracing the progress of all art, from the earliest twilight ages of which little else than Homer's singing remains to us, on through the rise and meridian centuries of Grecian splendor, through Mediæval, Gothic and Renaissance times, we are bound to consider the influence of religions—be they Pagan or Christian—since so many of its greatest works were wrought in their behalf. So in Russia, art is so much an expression of religious feeling, that we must turn to the churches and monasteries to

crosses, sceptres, mitres, censers, lamps, reliquaries and the hundred things used in the service will be found to be exquisitely wrought and of rare value.

It is always a difficult thing to trace any national art to its origin. There is much that must always remain obscure, and Russian art is no exception, but it is certain that it owes its origin to Oriental influences. There are evidences of the influence of India, of Greece, of Persia, of China even, of Byzantium, and in later times of Italy and Western Europe.

The enormous wealth of Russia in minerals and precious stones is well-known and has always attracted incursions of lawless tribes. From the west and the shores of the Baltic came the hordes of Northmen. Siberia which covers an area of more than five million square miles, reaching from Japan to the Ural Mountains, is rich in gold and silver. The mountains furnish amethysts, topaz and emeralds. Malachite is abundant. Across this vast territory came the Huns on their way to the west. The Tartars followed them, and they in turn were followed by the Ottoman hordes. Each of these tribes left its impression upon the land invaded.

From the earliest times travelers have brought back reports of the wonderful riches of the courts of the Czars—the magnificent thrones, crowns, coronets, jewels and trappings as well as the wonderful collection of plates. In several of the fires which devastated Moscow the Kremlin

suffered great loss; again, much has disappeared through pillage and depredation; at other times quantities of ancient plate and

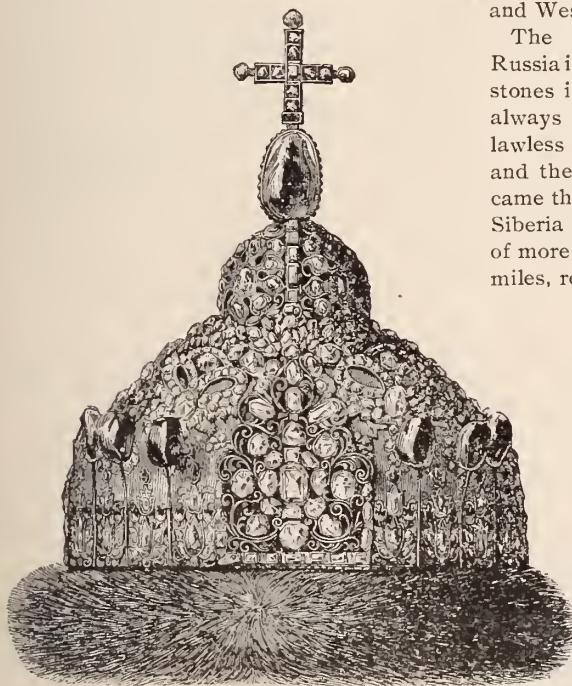

CROWN OF PETER ALEXEIVITCH  
WROUGHT OF GOLD ENCRUSTED WITH JEWELS.

trace its growth. Not only the churches themselves stand as an expression of the life of the people, but also the vestments,

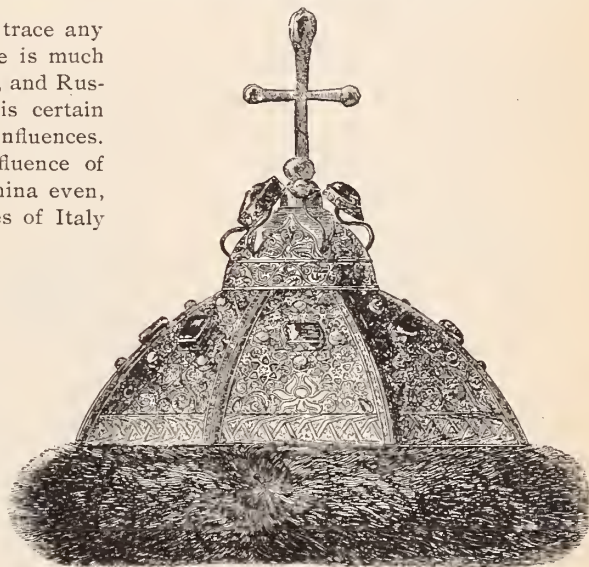

CROWN OF MONOMACHUS  
OF GOLD ENGRAVED AND STUDED WITH GEMS.

gold and silver objects were melted down and converted into money to pay off the soldiers. Notwithstanding these vicissitudes much still remains, and supplemented by the numerous presents brought by ambassadors from all countries, are to-day to be seen in the treasuries of the Kremlin and are of wonderful interest.

A chronicler of the 17th century tells us that the Russian artisans were wonderfully skilful, and from the Imperial workshops came a stream of beautiful things, which were carried east and west. In examining the products of that time we find a lavish display of material wealth in gold and jewels, and gorgeous color, producing an effect



# DEITSCH BROS.,

7 EAST 17TH ST., NEW YORK.

## LEATHER GOODS.

EBONY AND SILVER COMBINATIONS.

ORIGINATORS AND MAKERS OF

NOVELTIES IN LEATHER AND STERLING SILVER COMBINATIONS.



\*\*\*\*\*

### CROSS & BEGUELIN,

17 MAIDEN LANE, NEW YORK,

ALL GRADES OF SWISS AND AMERICAN WATCHES, DIAMONDS, GOLD AND ROLLED PLATE JEWELRY, OPERA AND FIELD GLASSES, TOOLS AND MATERIAL.

SOLE AGENTS FOR THE **Rockford Watch Co.** MATERIAL.

MANUFACTURERS OF THE **Centennial Watches.**

SEND FOR OUR WATCH MATERIAL AND TOOL PRICE LIST FOR 1894.

\*\*\*\*\*

### AMERICAN SYNDICATE OF Jewelers' Auctioneers.

ESTABLISHED for the sole purpose of conducting sales for established Jewelers in the United States, Canada and Mexico. We do not sacrifice your goods. We take no sales on a percentage. Our terms are strictly one-half the profits realized on all goods sold. We guarantee you against any loss. We pay all our own expenses; we don't ask you to pay one cent of expense on our account. We buy stocks complete as well as sell them. If your stock is small, or your assortment is not complete, we will furnish from one to ten thousand dollars worth of any kind of stock you may need and in which you need not invest one penny. Don't make any arrangements with others until you read our pamphlet which we will send you free, giving you full particulars of our style of doing business, and the liberal offers we make to Jewelers. We don't care how small your stock is, we will furnish all the stock you need to make a successful sale. We challenge the world for any fairer or more liberal propositions than we make Jewelers. Don't fail to send us your address, and we will send you our business pamphlet, which gives you full explanations as to our terms and style of doing business. Address,

### AMERICAN SYNDICATE OF JEWELERS' AUCTIONEERS.

Offices: 20 WEST 14th STREET, NEW YORK. 611 PENN AVE., WASHINGTON, D. C.

### "THE BEST BUTTON MADE."

THE KREMENTZ

IN GOLD FROM KREMENTZ & CO. AND ALL JOBBERS.



ONE PIECE FROM ALL JOBBERS

IN ROLLED PLATE

### COLLAR BUTTON.

IS THE ORIGINAL ONE PIECE BUTTON.

IS STILL THE BEST AND STILL UNSURPASSED.

Sold by all wholesale dealers at manufacturer's price.

**A. N. CLARK,** PLAINVILLE, CONN.

Manufacturer of the Celebrated **LOOP WATCH KEY.**

The Best for the Price in the World. CROSBY'S JEWELING TOOLS IMPROVED.



Site of Square

Stamped on each key.

### CAMPBELL-METCALF SILVER CO.

Choice Conceits IN Sterling Silver ONLY.



TRADE MARK

2 Maiden Lane, N. Y., with Holmes & Edwards Silver Co. 66 Stewart St., Prov., R. I. Mills Bldg., San Francisco, 8th Floor, Room 1.

**JACOT & SON** IMPORTERS AND MANUFACTURERS OF **MUSICAL BOXES** 298 BROADWAY. NEW YORK



Will quote royalty or price for the manufacturing of articles of real worth.



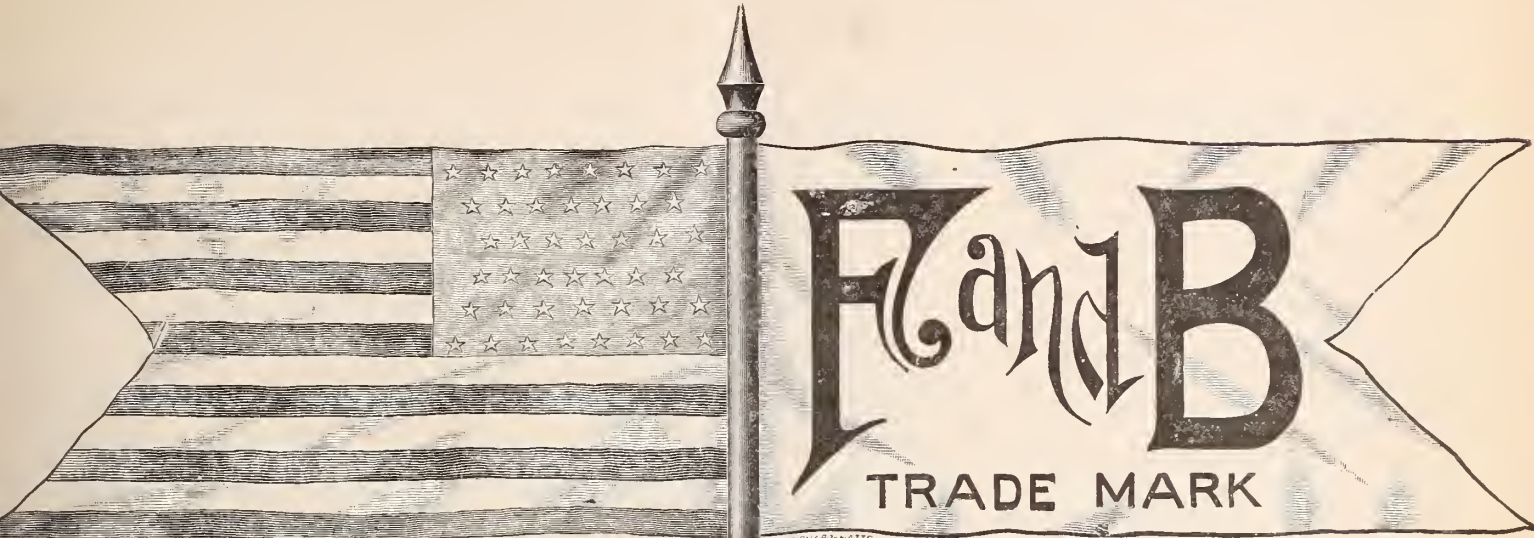

Our American F. & B.  $\frac{1}{10}$  Gold Chains will assay 10 K. 1-10 gold, and are guaranteed for ten years.

Our regular line of Chains is made of heavy gold plate, finely finished, and guaranteed for five years.



Mount Hope Button.

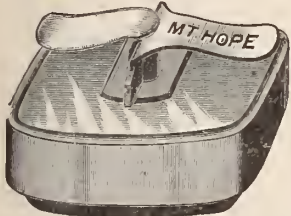

CLOSED.

**Chains**  
Our new line of chains will assay 10 karat 1-10 gold. All gold soldered.  
**American F. & B. 1-10 gold.**

WE RECEIVED  
**4 MEDALS**  
AT THE WORLD'S FAIR.

<p><b>Watch Chains for Gentlemen</b></p> <p>These goods are of fine quality, and guaranteed to give satisfaction. Some recently added have sold far beyond expectation. They are made of heavy rolled plate in all sizes and patterns.</p>	<p><b>Watch Chains for Ladies</b></p> <p>Our Victoria and Princess chains are neat and pretty. They are made in all bright, Roman and bright, platinum and bright gold, and have one or two charms.</p>
--	---

Mount Hope Button

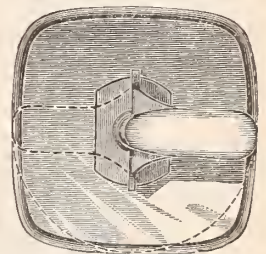

OPEN.

<p><b>Charms</b></p> <p>This line is adapted to ladies' or gentlemen's chains, and includes a number of heart charms in Roman, bright and satin finish, with stones and without.</p>	<p><b>Hair Chain Mountings</b></p> <p>In solid gold and rolled plate. We are headquarters and make everything desirable in this line.</p>	<p><b>Bracelets</b></p> <p>We make a large stock of curb bracelets in five sizes, besides the graduated links, with padlocks and snaps, in chased and plain polished, Roman, rolled silver plate and sterling silver. Also padlocks with keys and a push snap.</p>
--	---	--

<p><b>Pins</b></p> <p>Our large line of lace and cuff pins comprise many desirable patterns in gold fronts engraved and trimmed. Also includes baby pins and scarf pins.</p>	<p><b>"Mt. Hope" Buttons</b></p> <p>These are superior to any button in the world. They are easy to put in and easy to take out of the cuff.</p>	<p><b>Link Buttons</b></p> <p>This line has increased rapidly with us, and is very low in price, embracing all styles in Roman, chased, engraved and plain, with and without stones, and some in enamel.</p>	<p><b>Crosses</b></p> <p>We make four sizes of gold filled in plain, engraved and set with stones, and suitable for our neck chains.</p>
--	--	--	--

<p><b>Sterling Silver and Solid Gold Sword Scarf Pins</b></p>	<p><b>Glove Buttoners</b></p> <p>We make the interlocking and one with a twist handle in gold rolled plate and silver rolled plate.</p>	<p><b>Earrings</b></p> <p>This line includes many pretty patterns in gold fronts engraved, some with pretty trimmings and a small line of loop drops.</p>	<p><b>Neck Chains</b></p> <p>We make a variety of neck-chains in bright and Roman, with snaps.</p>	<p><b>Sterling Silver Bracelets and Padlocks</b></p>
---	---	---	--	--

	<p><b>Gold Lockets Set with Diamonds</b></p> <p>These lockets are made of 10 karat gold throughout and set with brilliant diamonds. They cannot be surpassed in finish or cheapness of price.</p>	<p><b>Gold Lockets Engraved</b></p> <p>These lockets are also made of 10 karat gold throughout, with beautiful designs engraved thereon and the price is so low that they cannot fail to be in great demand.</p>	<p><b>Gold Front Lockets</b></p> <p>This line is very extensive. Many patterns are plain polished, others nicely engraved, with and without stones.</p>	<p><b>Rolled-Plate Lockets</b></p> <p>This line is almost endless, and consists of nearly every conceivable shape, size and style. Some are set with imitation diamonds, rubies and sapphires.</p>	
--	---	--	---	--	--

We have put upon the market a line of Gentlemen's Chains and Ladies' Chain Bracelets made of 1-10 gold stock. Every joint is soldered with gold, and every Chain or Bracelet will assay more than 1-10 gold. They are our AMERICAN F. & B. 1-10 GOLD goods, and are so stamped. Bar, Chain and Swivel are stamped 1-10 gold.

**FOSTER & BAILEY, Providence, R. I.**



truly Oriental and which is best expressed by the term barbaric magnificence—a character of solid splendor which is wanting in refinement and delicacy, but which possesses a certain grandeur that is striking and original. Brilliancy is obtained by enameling, which is one of the characteristics of Russian work seen everywhere, from caskets and sceptres to the exteriors of churches, where tiles and plaques were used.

A custom of long standing is the offering of bread and salt to guests, and to day, when the Emperor makes official visits to any town the ceremonial of presenting bread and salt is maintained. This has brought into use certain elaborate trays and salt boxes of rare beauty and value. After the ceremonial the plate is presented to the Emperor. Furthermore, the long Winters and the general use of candles in the church service have led to much attention being given to candelabra, which are often found to be of great beauty.

**Death of G. Holmberg.**

WATERBURY, Conn., March 9.—A dispatch which the officials of the Waterbury Clock Co. received from Colorado Springs Tuesday, announced the death of G. Holmberg. He had suffered from lung troubles for several years. The Waterbury Clock Co. have instructed their Colorado representa-

tive to see that the remains have a suitable interment and that his affairs are properly



CENSER WROUGHT IN GOLD AND JEWELS, DATED 1598.

attended to. Mr. Holmberg was 36 years of age. He was born in Russia of Swedish par-

entage. He came from Torrington to Waterbury ten years ago and accepted a humble job in the clock factory at \$1.50 a day. As the result of his rare efficiency and fidelity he steadily rose to the assistant superintendency of the case department. He speedily won the absolute confidence of his employers. He was highly educated and was a master of most of the Continental languages. The announcement of his death has caused regret among his former employers and his acquaintances in this city.

**A New Corporation to Conduct Jewelry Stores.**

PUEBLO, Col., March 8.—S. J. Rushmer, Lawrence, Kan., and Gorton Rushmer and W. B. Rushmer, of this city, have incorporated the Rushmer Jewelry Co. with a capital stock of \$15,000 in single shares of \$100.

The business to be prosecuted is the conducting of jewelry stores in Pueblo and El Paso counties, this State.

**A Jewelry Store Burglar Supposed to be Captured.**

NEW BRUNSWICK, N. J., March 9.—A few days ago Geo. Henry, aged 20, was committed on a charge of forging checks. Wednesday commitments were lodged against him on charges of being connected with burglaries at A. Craig Voorhees' store. He is now held on five charges.

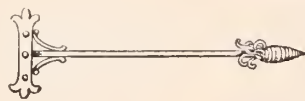

**MATHEY BROS., MATHEZ & CO.,**

21 & 23 MAIDEN LANE, N. Y.  
BRASSUS, SWITZERLAND.

Manufacturers and Importers of  
Plain and Complicated  
WATCHES.

**SPLITS**

A SPECIALTY.

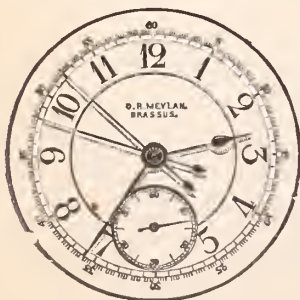

Sole Agents for **Jaques Lecoulre Razors.**

**VICTOR.**

SIMPLEST FEED. ALWAYS THE SAME.  
GUARANTEED FOR ONE YEAR.

**THE VICTOR  
FOUNTAIN PEN**

(Pat. Feb. 4, 1890.)

THE BOSTON PEN CO.,

N. C. Whitaker & Co., Proprietors.

363 Washington Street, Boston, Mass.,  
Manufacturers of finest quality

TORTOISE : SHELL : AND : HORN : GOODS  
in every variety. Also Aluminum Hair Pins.  
Send for illustrated Pen Price List No. 1.

WHITE'S EYE SHADE. **W. B. WHITE & SON**  
MANUFACTURERS OF



Spectacle and Eye Glass  
CASES

90 SOUTH STREET, BOSTON.

Special Cases made to order for Optical Trade. Cases for Trial Lenses. Opera Glasses recovered, etc. Chateleine Spectacle Cases, Metal Bound Leather Cases for combs, scissors, etc. Over forty kinds of cases manufactured.

**THEODORE C. STEINHAUS,**

— MANUFACTURER OF —

**Fine Cases and Trays**

For JEWELRY, SILVERWARE, &c.  
SAMPLE CASES AND TRAYS FOR TRAVELERS.

Fancy Hard Wood Chests for Silverware, &c.  
Linings, Cushions, Mounting, etc., for Silver Novelties.

10 MAIDEN LANE, NEW YORK.



We have in Stock  
 ... THE ...  
 Largest Line of  
**RICH CUT** \*

... AND ...

Decorated Art Glassware  
 IN AMERICA.



No. 671. PICKLE OR OLIVE DISH.

THE  
*Pairpoint*

MAKERS OF "SUPERIOR"  
 GOLD AND SILVER PLATE  
 In Hollow and "1880" Flat Ware.

MFG. COMPANY.

FACTORIES:  
 New Bedford,  
 Mass.

SALESROOMS:

NEW YORK, - 20 Maiden Lane.  
 CHICAGO, - 224 Wabash Ave.  
 SAN FRANCISCO, 220 Sutter St.

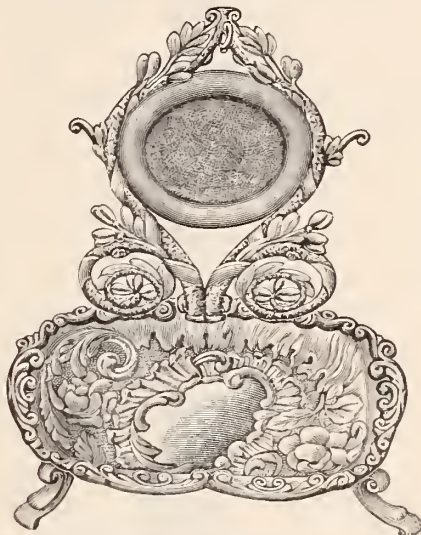

No. 940. EMBOSSED PIN TRAY AND WATCH STAND COMBINED.



No. 939. TRINKET TRAY, RING STAND AND PIN CUSHION. (PATENT APPLIED FOR.)

**A. J. LOGAN,**  
 MANUFACTURER OF  
 WATCH TOOLS, HAIR SPRINGS AND  
**WATCH MATERIALS.**  
 ◀ New Catalogue just issued, Sent on Application. ▶  
 WALTHAM, MASS.

If Your Sales  
 Are Not Satisfactory

ADDRESS  
**DE B. O. SCOTT,**  
 20 Murray Street, New York.  
 AUCTIONEER.

Specialties: Watches, Clocks, Bric-a-Brac, &c.  
 Write for particulars and references

AWARD AT WORLD'S FAIR, CHICAGO, 1893.  
 The Providence Shell Works.  
**W. K. Potter,**  
 346 Westminster St., Providence, R. I.



Tortoise Shell Goods, Combs, Hair Ornaments, Jewelry, Etc.  
 Shell Work made to order on contract. Repairing for the trade in all its branches.

We sell to the legitimate Jewelry and Stationery trade only.



CHOICE PAPERS  
 MAKERS OF  
**FINE STATIONERY**

For Correspondence, Wedding and Business Use, handsomely boxed, specially suited to the Jewelry Trade.

18 MURRAY STREET, NEW YORK.



# R. WALLACE & SONS MFG. CO.

SILVERSMITHS

Trade Mark.



R. W. & S.  
Sterling.

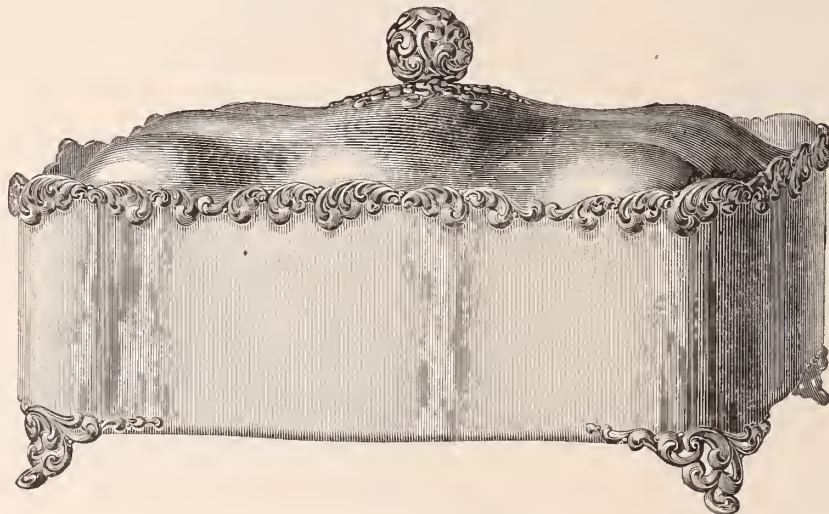

WAVERLEY SARDINE BOX.

Manufactories and  
Main Office,

WALLINGFORD, - - CONN.

BRANCHES :

NEW YORK  
3 PARK PLACE.

SAN FRANCISCO,  
120 SUTTER STREET.

CHICAGO  
86 WABASH AVENUE.



**Imports and Exports for January, 1894, and the Preceding Seven Months.**

WASHINGTON, D. C., March 8.—The summary statement of imports and exports for the month ending Jan. 31, 1894, and the seven months ending the same date, compared with the corresponding periods of 1893, has been issued and contains the following figures relative to the jewelry trade:

**IMPORTS:**—Diamonds and other precious stones, rough and uncut, including glaziers' and engravers' diamonds not set, and jewels to be used in the manufacture of watches, Month of January, 1894, \$64,662 against \$60,372 same month of 1893, and \$28,988 in December; clocks and parts of, January, 1894, \$2,579 against \$10,862 same month of 1893, and \$4,453 in December; watches and parts of, and watch materials and movements, January, 1894, \$76,515 against \$115,558 same month of 1893, and \$92,286 in December; jewelry and manufactures of gold and silver, January, 1894, \$51,101 against \$79,150 same month of 1893, and \$18,484 in December; precious stones and imitations of, not set, January, 1894, \$193,865 against \$1,563,545 same month last year, and \$254,752 in December; platinum unmanufactured, January, 1894, \$21,886 against \$85,791 same month last year, and \$31,109 in December.

**EXPORTS OF DOMESTIC MERCHANDISE:**—Clocks and parts of, January, 1894, \$44,978 against \$38,736 same month last year, and \$72,355 in December; watches and parts of, January, 1894, \$16,998 against \$23,177 same month last year, and \$21,278 in December; jewelry and manufactures of gold and silver, January, 1894, \$53,268 against \$53,608 same month last year, and \$71,869 in December; plated ware, January, 1894, \$11,334 against \$33,048 same month last year, and \$25,835 in December.

**IMPORTS,** for seven months ending Jan. 31, 1894:—Diamonds and other precious

stones, rough and uncut, etc., \$301,039 against \$561,260 in 1893; clocks and parts of, etc., \$89,781 against \$187,731 in 1893; watches and parts of, etc., \$728,671 against \$1,046,231 in 1893; jewelry and manufactures of gold and silver, \$368,296 against \$385,797 in 1893; precious stones and imitations of, not set, \$2,158,561 against \$8,684,616 in 1893; platinum, unmanufactured, \$186,031 against \$350,903 in 1893.

**EXPORTS OF DOMESTIC MERCHANDISE,** for seven months ending Jan. 31, 1894.—Clocks and parts of, \$501,690 against \$536,906 in 1893; watches and parts of, \$250,082 against \$112,825 in 1893; jewelry and manufactures of gold and silver, \$530,660 against \$404,349 in 1893; plated ware, \$188,323 against \$188,561 in 1893.

**EXPORTS OF FOREIGN MERCHANDISE.**—Diamonds and other precious stones, etc., January, 1894, \$20 against nothing and \$20 against nothing for seven months; clocks and parts of, January, 1894, nothing against nothing in January, 1893, and \$165 against \$1,037 for seven months; watches and parts of, etc., January, 1894, \$72 against nothing in January, 1893, and \$626 against \$290 in seven months; jewelry and manufactures of gold and silver, January, 1894, \$710 against nothing and \$12,694 against \$19,986 for seven months; precious stones, etc., January, 1894, \$54 against nothing in January, 1893, and \$311,359 against \$1,561 for seven months.

The comparative summary of values of merchandise imported and exported during the seven months ending January 31, from 1889 to 1894, inclusive, shows the following anent the jewelry and kindred lines: Average of the preceding five periods, imports, clocks and watches and parts of, \$1,332,368, seven months ending January 31, 1894, \$818,452; imports, jewelry, manufactures of gold and silver and precious stones, average of the five preceding periods, \$7,874,793,

seven months ending January 31, 1894, \$2,526,857; exports, clocks and watches, average of the five preceding periods, \$827,966, seven months ending January 31, 1894, \$751,772.

**Akron Jewelers Wroth With the Business Methods of a Cleveland Firm.**

CLEVELAND, O., March 7.—Last week Jos. and Lewis Goldsoll, of this city, shipped a lot of goods to one Geo. W. Phillips, at Akron. No one had ever heard of Geo. W. Phillips there, and up to the present he has utterly failed to put in an appearance. But on Wednesday Jos. Goldsoll appeared in Justice Hansel's court at Akron, and began action against Phillips on a cognovit note for \$35. Judgment was awarded and the goods attached.

Major L. D. Walter had been retained as counsel and another note for \$8 went through the same process. Jacob Goodman, a law student, was appointed receiver and ordered to sell the goods to satisfy the claims.

Now the merchants of Akron claim the whole affair was a scheme to get an opportunity to sell the goods and avoid a license of \$25 per day. They say that Phillips is a myth, and the notes only a blind. Monday, Major Walter withdrew from the case but the Goldsolls were actively preparing a room in which to dispose of the goods under order of court, and without paying a cent of license.

**A Failure in the New South.**

RALEIGH, N. C., March 8.—William Thain, jeweler, who has for many years been doing business on Martin St., opposite the post-office, has made an assignment, designating M. B. Barbee as assignee.

The liabilities are small and it is thought that the assets are sufficient to cover them and the homestead.

**WE DO NOT CLAIM THAT OURS ARE THE CHEAPEST OR THE "LICHEST WEICHT" GOODS IN THE MARKET, BUT WE STILL ASSERT THAT OUR STERLING SILVER BELTS ARE UNRIVALED IN LOW PRICES, EXCELLENCE OF FINISH AND ARTISTIC CONCEPTION.**

**\$1.75 for this Belt Complete.**

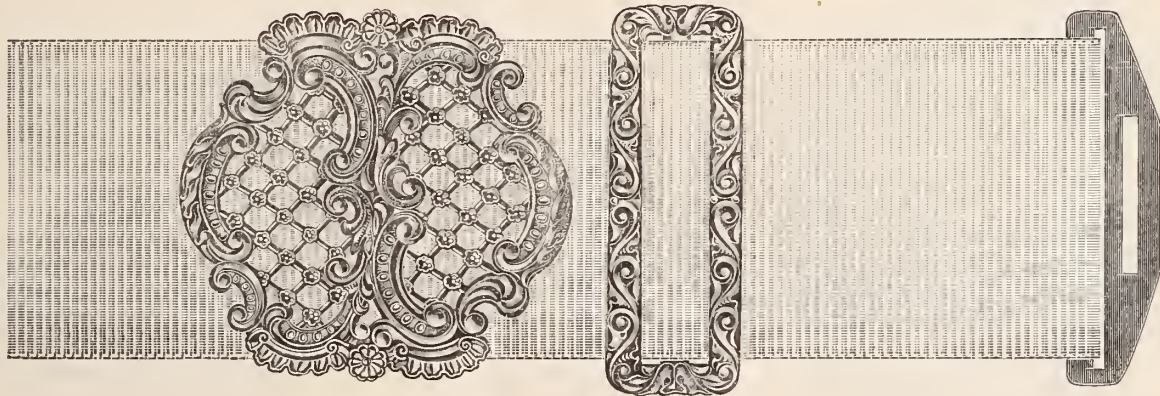

**\$1.75 for this Belt Complete.**

Bright Cut STERLING Silver (no filling), Mounted on Highest Grade of Imported Silk Webbing. An endless variety of patterns.

**JNO. W. REDDALL & CO.,**

**107 HAMILTON ST., NEWARK, N. J.**

Fourteen Karat Gold, and Sterling Silver Goods of superior make and finish, at salable prices.



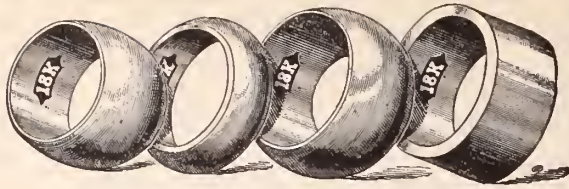

Band Rings metal lapped. Full value allowed for old gold.

**PLAIN SOLID GOLD RINGS.**  
**HILDRETH MFG. CO.,**

53 MAIDEN LANE,

NEW YORK.

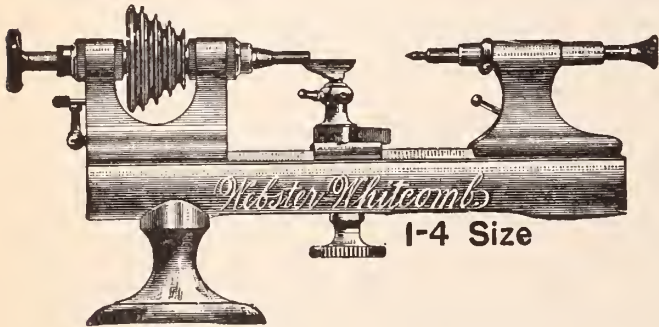

STRONGEST GUARANTEES.

Quality  
Maintained.

Prices to  
Suit the Times.

Ask for our New  
Prices and  
Terms for 1894.

**American Watch Tool Company,**

Chymistry Dist., Waltham, Mass., Stony Batter Works.

**DÜRRSTEIN & CO.,** Watch  
Manufacturers,

**DRESDEN AND GLASHÜTTE,**  
**GERMANY.**



**SPECIALTIES:** Repeaters, self-striking minute and quarter repeaters, chronographs, chronometers, finest Glashütte anchor watch (patent union) in sizes for ladies and gents, in plain cases and in cases richly chased, engraved, enameled and diamond set.

PRODUCTS OF FACTORY FOR SALE  
BY LEADING JEWELERS.

REPRESENTED BY

**Richard Horstmann,**

BERLIN, S. W.  
ORANIENSTRASSE 101, 102.

**Litigation in the Failure of the Philadelphia Optical & Watch Co.**

PHILADELPHIA, Pa., March 8.—A petition has been filed suggesting a diminution of record in the appeal of the Keystone Watch Case Co. from the decree of Common Pleas Court No. 3 of this county, in the case of the Pairpoint Mfg. Co. and others against the Philadelphia Optical & Watch Co. The petition was filed by James Work and the Guarantee Trust & Safe Deposit Co., receivers of the Philadelphia Optical & Watch Co.

They state that the appeal was taken on Feb. 16th last, and upon a certiorari being made out, it was found that the record taken up to the Supreme Court did not contain the affidavit of Arthur H. Williams, Jr., which had been used at the argument of the case in Court No. 3, which the receivers proposed to use in the argument in the Supreme Court, but which had not been placed on record in Court No. 3. That on the 5th inst., the receivers filed a petition in Court No. 3, asking that the court make an order directing that the affidavit be taken and considered as already filed of record. Court No. 3 made this order, and the peti-

**HENRY ABBOTT,**

MANUFACTURER OF

Stem-Winding Attachments  
FOR WATCHES,

No. 2 Maiden Lane, NEW YORK.

**G.A. WEBSTER**

42 & 44 Madison St., Chicago, Ill.

**Manufacturer,**  
AND WESTERN AGENT FOR

E. G. WEBSTER & SON, of Brooklyn, N. Y.  
A. F. TOWLE & SON CO., of Greenfield, Mass.

PATENT PANELED METAL

**CEILING**

Stamped Raised Panels.

ARTISTIC AND PERMANENT.

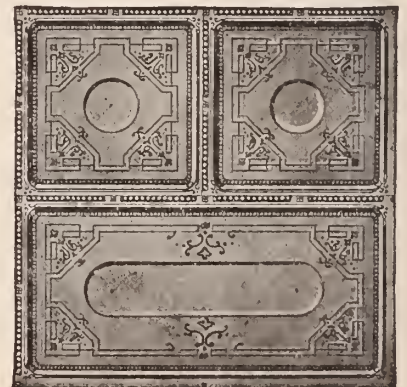

Easily applied in new buildings, and over old broken plaster or wood Ceilings. If interested in building or repairing, send stamp for Illustrated Catalogue, and state if **CHURCH, HALL, STORE, OFFICE,** or **SCHOOL** Ceiling is wanted. Address

**A. NORTHROP & CO.,** Pittsburg, Pa.



tioners ask the Supreme Court to issue a writ directing that the affidavit be brought up and made a part of the record.

**W. C. Bryant Has an Adventure with a Suspicious Customer.**

BANGOR, Me., March 9.—One morning this week, a short, nervous appearing young man called at the store of W. C. Bryant, and said to the proprietor: "That watch I bought of you a short time ago gives excellent satisfaction, and I want to get another something like it." Mr. Bryant learned from him that he wanted to buy something costing from \$35 to \$40, and showed him a lot of watches of about that price. After expressing his approval of one watch, he said he would call again after dinner.

He came in again and wanted to know if he could take the watch out at supper time for examination. Mr. Bryant began to be a little suspicious and sent one of his clerks to watch the man. It was found that he went to the Maine Central station and apparently wanted to buy a ticket to go away on the evening train. The ticket office was closed, however.

When it was about time for the young man to make his appearance again, Mr. Bryant had two policemen stationed in the back part of the store. The man came on time. Mr. Bryant asked him if he wanted to leave a deposit on the watch while he took it out; the man said that he would be glad to and asked for how much. Mr. Bryant said for the full value and if he did not keep the watch, the deposit would be returned to him. During this conversation the young man had been edging toward the door and suddenly opening it he started on a run down the street and that was the last seen of him.

L. Tannenbaum, of L. Tannenbaum & Co., who returned from Europe on Saturday last brought with him what he confidently claims to be the largest and finest invoice of precious stones ever imported by him. He offers special bargains and buyers will miss an opportunity if they fail to look at L. Tannenbaum & Co.'s goods.

**The Death of John Rutt Andrews.**

John Rutt Andrews, of Andrews & Doty, 207 Broadway, New York, until recently president of the American Turquoise Co., died in New York suddenly, of heart failure, Tuesday evening, March 6th. He had been complaining of ill health for some time. On Tuesday evening he called on Dr. Richard



JOHN RUTT ANDREWS.

Schofield, a relative, in W. 14th St., for an examination. He telephoned to his wife, in Englewood, N. J., that he was not as seriously ill as was feared, and would spend the night in the city. It was his farewell message. Shortly before 12 o'clock he retired, and in about half an hour he passed quietly away.

Mr. Andrews had been for many years a prominent figure in the jewelry business. His father, George R. Andrews, and the latter's brother, John R. Andrews, uncle of the deceased, were manufacturing jewelers in Fulton St. in the early fifties; and in 1854, they made arrangements to manufacture jewelry exclusively for Tiffany & Co. Some years later, John R. Andrews retired, and the firm became Andrews & Schultheis. John Rutt Andrews eventually succeeded Mr. Schultheis, and about 1862, when his father, George R. Andrews, retired, he took entire charge of the business.

In 1870, Tiffany & Co. purchased Mr. Andrews' entire plant. He then became a stockholder in that corporation and general manager of their jewelry manufacturing department. He withdrew from the business in September, 1882, and entered into partnership with A. de Cordova, as stock-brokers. In 1889, he formed a new partnership with Joseph G. Doty, under the firm name of Andrews & Doty, wholesale dealers in diamonds and precious stones, at 182 Broadway. Three years later Mr. Andrews became president of the American Turquoise Co., from which position he resigned about two months ago. The failure of Simon Dessau caused Andrews & Doty to assign Feb. 6th, and it is believed that the worry caused by his firm's assignment was the indirect cause of Mr. Andrews' illness which resulted in his death.

Mr. Andrews was an excellent judge of precious stones, and a very capable director in the manufacture of jewelry. He was a man of very fine presence and military bearing. In 1863 he enlisted as a private, under Capt. Smith, in the famous old Eighth Co., of the Seventh Regiment. He became very popular, and soon rose from the ranks to first lieutenant. He served over ten years in the regiment, and was presented with the long-service Cross of Honor medal. Upon retiring, he became a member of the Seventh Regiment Veteran Association, and was appointed on the staff of Major-General Shaler with the rank of major.

Mr. Andrews was a member of the Jewelers' League. He leaves a widow and one child, a married daughter. The funeral took place from his late residence, Englewood, N. J., on Saturday morning.

**A Brace of Light-fingered Gents Come to Grief.**

HARTFORD, Conn., March 7. — Richard Parker, 25 years old, of Brooklyn, N. Y., is a prisoner, charged with a bold theft in filching a \$25 gold watch chain from the store of David Mayer on Saturday afternoon. Parker with another man went into the store about three o'clock in the afternoon and asked to see some gold chains. A tray of chains was brought out and Parker,



TYROLEAN ALMOND SCOOP, No. 15.

WE MAKE A COMPLETE LINE OF HOLLOW WARE IN NUMEROUS ARTISTIC PATTERNS. NEW IDEAS CONSTANTLY.

**F. M. WHITING & CO.,**

Manufacturers of STERLING SILVERWARE, Novelties in Silver Jewelry.

NORTH ATTLEBORO, MASS.





# Easter Novelty

BOOK MARKERS WITH FOUR (4)  
SOLID SILVER TOKENS, MOUNTED  
ON CARD BOARD WITH THE WORDS

## "EASTER GREETING"

STAMPED WITH STEEL DIE AT  
TOP.

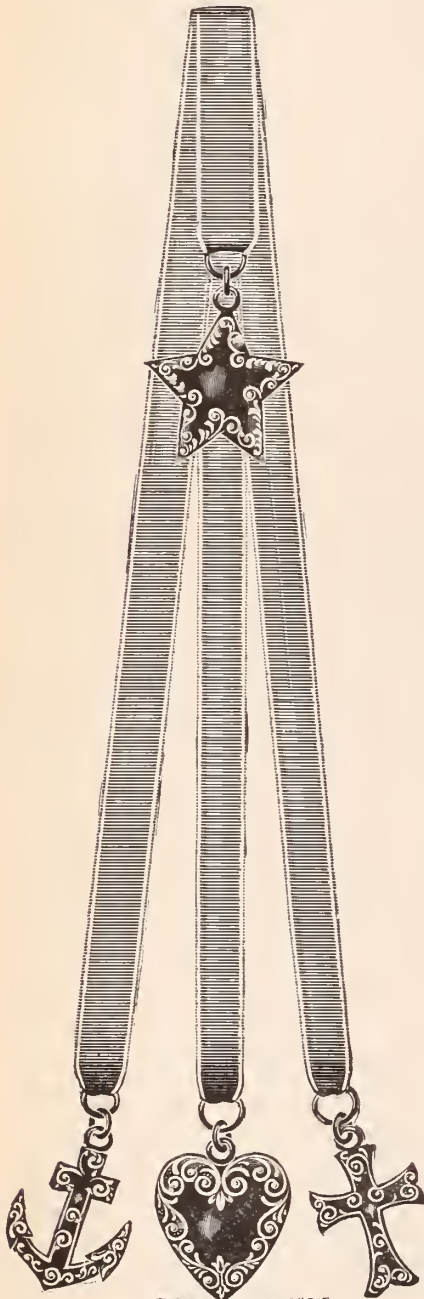

TRADE MARK JAN. 6 '94.

A QUICK SELLING AND POPULAR  
NOVELTY.

PLAIN FINISH,  
EMBOSSED, SEE CUT,  
EMBOSSED AND ENAMELED

PER DOZ.  
\$5.00  
9.00  
12.00

SEND FOR SAMPLES.

**QUEEN & CO.,**  
1010 Chestnut Street,  
PHILADELPHIA.

taking two of them, went over to the mirror to see how they looked. When his back was turned he slipped one of the chains into his gloves. Unfortunately for him, Maurice Mayer looked into the mirror and saw part of the stolen chain sticking out of the glove. He went for a policeman. In the mean time the men had left and the officer and Maurice Mayer started out to find them. Parker was caught, but the other man escaped.

The two men also went into Deming's store, under the Allyn House, but got nothing, as well as into Hansel, Sloan & Co.'s, where they remained ten minutes without buying anything. Judge Barbour imposed a fine of \$25 and a sentence of three months in jail. Parker's pal was arrested yesterday noon. His name is George White. He was fined \$7 and sentenced to 30 days in jail.

### Resolutions in Honor of Andrew Paul.

BOSTON, Mass., March 10.—At a special meeting of the Boston trade, held to take action on the death of Andrew Paul, the following resolutions were adopted, to be engrossed and forwarded to his family:

We, the manufacturers of and wholesale dealers in watches and jewelry, having assembled to express our sorrow and sympathy at the removal from earthly scenes of our honored associate and friend Andrew Paul, therefore it is

*Resolved,* That we desire to express our sincere sympathy with the family of our esteemed friend in this time of their great sorrow, and as we breathe the name of the Father of the Universe whose name is Love, we believe he will sustain and comfort them in their sad bereavement.

*Resolved,* That we who have stood near him in business interests would express our regard for him as a man in our daily contact with him, as well as in our various social relations.

*Resolved,* That a copy of these resolutions be presented to the family.

### A Jewelry Thief will Rest in Jail for Five Years.

LITTLE ROCK, Ark., March 8.—T. H. Aymes, who was arrested in St. Louis several weeks ago while in the act of swindling the E. Jaccard Jewelry Co., of that city, and sent here to answer a similar charge, was arraigned in the Pulaski Circuit Court this week. He pleaded guilty and was sentenced to five years in the penitentiary.

Aymes stole several valuable diamonds from jeweler C. S. Stiff, in this city, and afterward pawned the jewels here and at St. Louis.

### The Stock of Giles, Bro. & Co. Sold to the Highest Bidder.

CHICAGO, Ill., March 13.—The Giles, Bro. & Co. stock and State St. leasehold were sold, Saturday, to H. D. Spaulding, Boston, Mass., for \$39,000 on bids in open court. Spaulding and A. G. Schwab & Bro., Cincinnati, O., were the only bidders.

Bids opened at \$31,000 and rose \$500 at a time till the property was struck off. It is quite probable that a corporation will be formed to secure the good will and continue the business of the late firm. The present store will remain open under the receiver's management till the money is paid over.

### The Death of Sigmund Lorsch.

Sigmund Lorsch, resident partner of Sussfeld, Lorsch & Co., New York, and one of the most prominent figures among the importers of materials and optical goods, died at his residence, 47 E. 64th St., early Friday morning. He had been suffering from diabetes for the past seven years, and the disease took an acute turn Thursday night which resulted fatally. His death was a severe and unexpected shock to his friends throughout the jewelry district, many of whom had seen him at his office, 13 Maiden Lane, as late as Wednesday last.



SIGMUND LORSCH.

Mr. Lorsch was born in Munich, Germany, Jan. 15, 1837, and received his education in that city. In 1849 he came to America and began his business career some few years later. After traveling for several jewelry houses he became connected with Sussfeld, Lorsch & Co., importers, in which his brother Joseph was a partner; he was admitted as a member about 1859. From that time Mr. Lorsch has been identified with the New York branch of this house, and since the death of Mr. Nordlinger in 1883, has been the only resident partner.

Mr. Lorsch, who is the brother of Albert Lorsch, of Albert Lorsch & Co., was prominent both in business and social life. He was noted for his numerous charities and was connected with many Hebrew benevolent and charitable organizations. He was a member of the Empire City Lodge, I. O. B. B., and the Jewelers' League, besides being a former director of the New York Jewelers' Board of Trade.

The deceased was married in 1865. A widow, three grown sons and a married daughter survive him. The funeral services were held at his late residence, Sunday morning, the interment taking place at Cypress Hills Cemetary.



**The Death of Jules F. U. Jurgensen.**

A prominent figure passed from the world of watchmaking in the death of Jules Frederic Urbain Jurgensen, which occurred at Locle, Switzerland, Tuesday, Feb. 19th. Mr. Jurgensen was the son of Jules Jurgensen who died in 1877.



JULES F. U. JURGENSEN.

Jules F. U. Jurgensen was born in Locle in September, 1837. He received his education at Geneva, where he was a pupil of M. Challet Venel, *ancien consuller federal*, with whom he ever afterward sustained the friendliest relations. While his education was a thorough one, the practical side of life was not neglected. He served a full apprenticeship at watchmaking and worked with some of the best known manufacturers in his country. Returning to Locle, he assumed the direction of his father's affairs, continuing the business after his fathers' death.

A good business man, he was also a lover of art and literature. He was a member of *La Société Cantonale d'Histoire*, and in this position was connected with *La Société d'Emulation du Doubs*. He was much interested in public instruction and was president of the school commission. Having been made an honorary citizen he was

elected deputy to the Grand Counsel, where he sat between the left and the right. He was also decorated with the cross of the *Legion d'Honneur* by the French Government.

A short sketch of the Jurgensen watch would seem appropriate, and will bring out the deceased's connection with the house of Jurgensen. The founder of it was Urbain Jurgensen, of Copenhagen, Denmark, who, in the latter part of the 18th century, went to Locle, Switzerland, to learn watchmaking. There he worked as a pupil of the scientist and celebrated watchmaker, Jacques Frederic Houriet, whose daughter he married. After he returned to Copenhagen he acquired a high reputation as a maker of marine chronometers. Later, he sent his son, Jules Jurgensen, to his relatives in Switzerland, for the purpose of learning both theoretical and practical watchmaking. Jules Jurgensen was a man of talent and education, and soon built up a large business, and became one of the most famous manufacturers in Switzerland. The reputation of his chronometers is well-known in this country. His New York agents were Jno. E. Hyde's Sons, who developed the trade for the Jurgensen watch in the United States to the degree everyone is cognizant of. Jules Jurgensen retired from business

in 1875, and his son, Jules Frederic Urbain Jurgensen, succeeded to the business and had up to his death sent his chronometers to his trusted friends and father's agents, J. E. Hyde's Sons.

Mr. Jurgensen possessed literary tastes, and conducted the watch business more as an amateur, but he never allowed the quality of his watches to diminish in the least.

**LOOKING FOR THE COLUMBIAS?**

AN ADJUSTABLE EYE-GLASS THAT CAN'T BREAK NOR GET OUT OF ORDER.

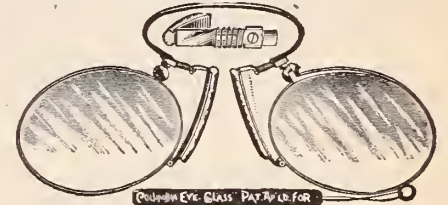

DON'T BUY UNTIL YOU SEE ONE OF OUR COLUMBIAS.

**E. KIRSTEIN'S SONS CO.,**

SOLE MANUFACTURERS, ROCHESTER, NEW YORK.

Send us your Rx. work, when you want same at once.

Send for Samples.

**Easter Gifts,**

Prayer-Book Marks, Spoons, Letter Openers, Button Hooks and all the latest in **STERLING SILVER NOVELTIES.**

MANUFACTURED BY

**CODDING BROS. & HEILBORN.**

North Attleboro, Mass.

Chicago office, Buck & Hall, 103 State St., Rm. 802.  
New York office, C. A. Vanderbilt, 178 B'way.

**FINE CHAMOIS SKINS.**

BEST & CHEAPEST IN THE MARKET.

By the Kip or in Small Quantities.

MANUFACTURED BY

**GEO. H. TAYLOR.**

GEORGE C. TAYLOR, Agent.

HAVEMEYER BUILDING, 26 CORTLANDT STREET, N. Y.

◆◆◆ The Most Unique Easter Novelty Ever Offered. ◆◆◆



**A GENUINE AFRICAN**

**Ostrich Egg,**

Mounted in Sterling Silver.

Eggs are 6x4½ inches with shells ⅓ in thick.

WILL LAST FOR YEARS.

Sell on Sight.

HANDSOME SHOW CARDS WITH EACH DOZEN.

**LEWIS BROTHERS,**

41-43 MAIDEN LANE, N. Y!

\$18.00 PER DOZ. NET.

**ONE YEAR'S SUBSCRIPTION**

—TO—

**The Jewelers' Circular**

—At \$2.50,—

Entitles the subscriber to a copy of "WORKSHOP NOTES" free, a 200 page book, bound in cloth, containing a fund of information for the workshop that can be found in no other work.



# NEW AND ORIGINAL

12 Different Patterns Now Ready for Delivery.

# COLLAR BUCKLES.

PRICES: \$1.00 TO \$1.75.

STERLING SILVER (.925 FINE) BRIGHT CUT.



No. 9893. \$1.35.



No. 9888. \$1.00.



No. 9890. \$1.60.



No. 9874. \$1.65.



No. 9876. \$1.65.



MAKERS OF  
Fine Jewelry

IN  
14 KARAT GOLD  
AND  
STERLING SILVER  
AT  
SALABLE PRICES.

**UNGER BROS.,** 192 BROADWAY, NEW YORK.



# The Jewelers' Circular

AND  
HOROLOGICAL REVIEW.

PUBLISHED EVERY WEDNESDAY BY  
**THE JEWELERS' CIRCULAR PUB'G CO.,**  
189 BROADWAY, NEW YORK CITY.

A JOURNAL DEVOTED TO THE INTERESTS OF  
JEWELERS, WATCHMAKERS, SILVERSMITHS,  
ELECTRO-PLATE MANUFACTURERS, AND ALL  
ENGAGED IN KINDRED BRANCHES OF INDUSTRY.

Our Editorial columns will contain our own opinions only, and we shall present in other columns only what we consider of interest or value to our readers. Advertising matter will not be printed as news.

Advertising rates in THE CIRCULAR are lower, considering the number of tradesmen reached by its large circulation, than in any other jewelry journal.

Notices of changes in standing advertisements must be received one week in advance; new matter can be received up to Monday.

## INFORMATION FOR SUBSCRIBERS.

### Terms of Subscription, Postage Prepaid.

	PER ANNUM
United States and Canada, . . . . .	\$2.00
Foreign Countries in Postal Union, . . . . .	4.00
Single Copies, . . . . .	.10

New subscribers can commence at any time.

Payments for THE CIRCULAR, when sent by mail, should be made in a Post-Office Money Order, Bank Check or Draft, or an Express Money Order or Registered Letter. All postmasters are required to register letters whenever requested to do so.

Pay money only to authorized collectors having proper credentials.

Returning your paper will not enable us to discontinue it, as we cannot find your name on our books unless your address is given.

In changing address always give the old as well as new one. Your name cannot be found on our books unless this is done.

We will continue to send papers until there is a specific order to stop, in connection with which all arrearages must be paid; but such an order can be given at any time, to take effect at the expiration of the subscription. All such orders will be promptly acknowledged by mail.

The Courts have decided that all subscribers to journals are responsible until arrearages are paid in full and an order to discontinue has been received by the publisher.

Member of the American Trade Press Association.

Vol. XXVIII. March 14, 1894. No. 6

**F**ROM various items of news received from Connecticut, it is to be inferred that business is reviving in that busy section of the country, and that the immediate prospects are brighter than they have been for several months past.

**T**O judge from the lively projecting of new silverplated ware factories in the vicinity of Wallingford, Conn., it is evident that many persons firmly believe that there is money to be made in this line of manufacture. This opinion, we understand, is not shared by every person already interested in the industry.

**The Passing of Three Men.** IT has often been observed that notable events occur in rapid succession, this phenomenon being particularly true regarding death. During the past week the deaths of three prominent men in the trade were announced within a day of one another. Each of these gentlemen, whose earthly

# Spanish-American Edition of The Jewelers' Circular.

In our opinion, the tariff agitation, notwithstanding the changes that may be effected in the Wilson Bill by the Senate, will make it necessary for our manufacturers to seek a more extensive trade than they have heretofore possessed. The export field offers this opportunity. We all recognize the countries of Mexico, Central America, Cuba and South America to be a most desirable field for American manufactures.

With a view to bringing the productions in the lines represented by THE CIRCULAR more prominently before the dealers in jewelry, etc., in these countries, we will issue about March 28th an Export Edition of THE JEWELERS' CIRCULAR for circulation in the above countries, including all the jewelers of Mexico, Central America, Cuba and some of the large cities in South America.

This edition will be printed, both advertisements and reading matter, in pure Spanish, and will be finely illustrated. If you desire space in this number please communicate with us at once and rates will be made known upon application. Copy for advertisements is to be sent to us in English, which we will properly translate into Spanish.

Yours truly,

The Jewelers' Circular Publishing Co.

career the grim reaper deemed it time to cut short, was a remarkable personage in a distinct branch of our trade. Jules F. U. Jurgensen occupying a position scarcely higher in the world of watchmaking than did Sigmund Lorsch in the optical goods industry and John R. Andrews in that of precious stones. Though their fields of activity differed so widely, the careers of the three men were similar in more than one regard, the spirit of progressiveness actuating all and producing a large measure of commercial success, without the sacrifice of the noble qualities of undeviating integrity and straightforwardness. Of nearly one age, they had apparently several years of usefulness before them, and their decease will be regretted by the different industries generally as well as by their many individual friends.

tion of unused tickets and for such portions of the same as may be presented, perhaps there may be, after all, no strong objection to the abolition of the "scalping" business.

## The Week in Brief.

**N**EWs was received of the death of Jules F. U. Jurgensen, of Locle, Switzerland—Wm. L. Sexton resigned from the secretaryship of the Jewelers' League—The death occurred of John R. Andrews, of Andrews & Doty, New York—Two jewelry thieves were captured in Hartford, Conn.—W. E. Fleissner, formerly a jeweler of Manistee, Wis., is in jail in Chicago, charged with larceny—The death occurred of Sigmund Lorsch, of Sussfeld, Lorsch & Co., New York—H. H. Boss, New London Wis., assigned—The store of William H. Welch, Demopolis, Ala., was burned out—A bill was introduced in the Rhode Island Legislature designed to regulate the sale of silverware—The Valparaiso Mfg. Co., Valparaiso, Ind., incorporated to manufacture clocks, watches, etc.—Burglars endeavored to rob two jewelry stores of Montreal, Can.—Cramton Bros., Warren, O., assigned—A judgment for \$47,000 was entered against E. A. and G. B. Hosier, Kansas City, Mo.—Creditors in Switzerland entered suits against the Columbus Watch Co.—Charles Jacques, of the Charles Jacques Clock Co., New York, was arrested—The stock and leasehold of Giles, Bro. & Co., Chicago, were sold to the highest bidder—The business of Edward Eaves, Montreal, Can., is to be liquidated.

## Of Interest to Travelers.

**T**RAVELING salesmen will be interested in a bill recently introduced in the Senate of the United States, making it unlawful for anyone to sell railroad tickets without due authority from the company whose tickets are offered, and making it also illegal for any railroad company to place its tickets in the hands of any other than authorized agents. It is plain that such a bill is designed to put an end to the "scalping" business. It is a question whether an individual has not a constitutional right to sell that which he has paid for and which he has bought in what may be called an open market. It cannot be denied that at times "scalped" tickets are of benefit to travelers, especially to those making short and rapid journeys between well known points. However, the principle of "scalping" is wrong, and as the measure before the Senate provides for the redemp-

J. W. Reddall & Co., Newark, N. J., have reduced the price on their belts, as announced in their advertisement on page 16. The advertisement of this firm on page 7 is inserted through an error on our part and should be disregarded by the trade.



**New York Notes.**

Jno. B. Yates returned Saturday from a short trip to Florida.

L. Tannenbaum returned from Europe Saturday on the *Umbria*.

Leopold Weil has entered a judgment for \$67.73 against Herman Harris.

Jno. B. Shea, of Aikin, Lambert & Co., is on a pleasure trip through Florida.

Frank Frey, 172 Ave. B, has given a chattel mortgage on jewelry fixtures to Julius Frey for \$165.

The sale of the stock and fixtures of Simon Dessau, 4 John St., will take place to-morrow, Thursday morning.

B. H. Davis & Co. will remove May 1st from 24 Maiden Lane to the Sheldon building, Nassau and John Sts.

The Manhattan Watch Co. have satisfied the judgment for \$898.25 entered against them March 5th by James L. Ely.

Another attachment has been issued against the Craighead & Kintz Co. in favor of Horace Craighead, for \$2,311.95.

Jacot & Son, importers of musical boxes, have removed their office and salesrooms from 298 Broadway to 39 Union Square.

J. W. Richardson & Co. and Mayhew & Carrington who now occupy offices at 194 Broadway, will soon remove to 200 Broadway.

The engagement is announced of John Downing Alling, son of Wm. R. Alling, to Miss Lillian L. Woerz, the daughter of Mr. and Mrs. Geo. W. Woerz.

H. M. Condit, secretary of the New York Jewelers' Board of Trade, and Sol. Lindenberg, were both jurors in a case before Judge Sedgwick, of the Superior Court, Monday.

The marriage of Geo. Rynor Collis, with the Whiting Mfg. Co., to Miss Eleanor Louise Grayson, daughter of Col. J. T. Grayson, took place Saturday at Stamford, Conn. Rev. F. A. Brathwaite officiated.

Lorraine F. Dillebar, formerly an employe of W. J. & C. I. Smith, and at present assignee of that firm, has started in business for himself at 836 Broadway, having purchased the stock of S. C. Wallach & Co., at that address.

A. J. Comrie, jewelers' auctioneer, 182 Broadway, New York, is conducting the successful sale for the J. H. Hart corporation, of Brooklyn, the details of whose dissolution were published in last week's CIRCULAR.

M. Prager and B. F. Rees, New York, sailed March 7th for Europe on the *Teutonic*; J. C. Mount, of Randel, Baremore & Billings, and F. H. Bawo, of Bawo & Dotter, New York, left for Europe Saturday on the *Lucania*.

Vallentine's Plating and Repairing Works were recently removed to 258 Grand St. The quarters are commodious and the shop is equipped with the latest improved machinery. All work is under the personal supervision of I. Vallentine.

Judge Bishoff, of the Court of Common Pleas, Thursday granted an order extending the time to file the schedules of Andrews & Doty 20 days from that date. Geo. W. Glaze, the assignee, states that the death of Mr. Andrews will delay the preparation of the schedules.

At the annual meeting of the Jewelers' Protective Union, held March 5th, the following officers were all re-elected: President, Wm. R. Alling; secretary and treasurer, Ira Goddard; executive committee, S. Oppenheimer, J. C. Aikin, O. G. Fessenden, Solomon Bass and C. E. Hastings.

The seven motions mentioned in last week's CIRCULAR, for commissions to take the testimony of jobbers in different cities, in the suit of the Dueber Watch Case Mfg. Co. against the manufacturers of movements and cases, were granted Friday by Judge Ingraham, of the Supreme Court.

The protest of the diamond dealers opposite 5 and 7 Maiden Lane, against the orange color upon the buildings at that location, proved to be effective. The dealers most affected, J. T. Scott & Co., Henry Dreyfus & Co., Wilcox Silver Plate Co., Low, Weinberg & Co., Wallach & Schiele and Max Freund & Co. agreed to pay the expense of re-painting the buildings, and Elbridge T. Gerry and the Hoffman estate consented to the change. The buildings are now a sober drab.

Judge Townsend in the United States Circuit Court Wednesday heard the suit of Chas. M. Levy against Dattelbaum & Friedman. The suit is brought upon a patent for an interchangeable initial ring granted in September, 1888, to Thie & Levy, which the complainant, one of the joint inventors claims, is being infringed by the defendants, Dattelbaum & Friedman. Thie & Levy dissolved Jan. 21, 1890. The defengants claim to have brought the right to manufacture under the patent in question, from Otto Thie, the other joint inventor. H. Albertus West argued for the plaintiff and T. C. Campbell for the defendants. Decision was reserved.

James W. Hagan, in conjunction with Nicholas J. White and Harry Campbell Cornell, has purchased the entire plant and business of F. P. Locklin & Co., manufacturers of umbrella and cane heads in silver, gold, pearl and ivory, and of silver and gold novelties, and cut glass mounted with silver and gold. The new firm will be known as Hagan, White & Co., and will retain the old headquarters of Locklin & Co., at 63-71 Clymer St., Brooklyn, until next month, when they will remove the entire plant to New York. James W. Hagan has been a well-known and popular figure in the trade; he was formerly a partner in the firm of Miller Bros. & Co., with which house he was connected for over a quarter of a century. Since the dissolution of Miller Bros. & Co. he has been in business for himself at 47 Maiden Lane, as a dealer in diamonds, precious stones and diamond jewelry. N. J. White was for seven years superintendent

and general manager for F. P. Locklin & Co. It is the purpose of the new firm to go extensively into the manufacture of the lines specified, and to assume a position second to none in this branch of the trade. With a force of able travelers superintended by so experienced a salesman as Mr. Hagan, together with practical men at the helm of the manufacturing department, it is safe to predict success for the new firm.

The Board of United States General Appraisers Wednesday handed down the following decisions: In the appeal of Hammel, Riglander & Co. from the decision of the collector at New York, upon glass imported Sept. 22, 1893, assessing a duty of 25 per cent. under paragraph 211, as watch glasses, the importers claimed a duty of 1 3/8 cents per pound under paragraph 112; the Board decided that the merchandise was dutiable at that rate, and in addition thereto 10 per cent. ad valorem, under paragraph 118, for common window glass, bevelled. In the appeal of A. F. Fellheimer from a decision on imitation pearls imported Oct. 22, 1890, the appellants claimed duty at 10 per cent. ad valorem, as pearls, under paragraph 453, but were overruled.

The Jewelers' Individual Bowling Contest scores made Monday evening, March 12th, were as follows:

Woodland . . . . .134	Clifford . . . . .151
" . . . . .151	" . . . . .139
Woodward . . . . .179	Townley . . . . .146
" . . . . .213	" . . . . .145
Roll . . . . .189	Mangold . . . . .123
" . . . . .156	" . . . . .174
Thornbury . . . . .140	Thompson . . . . .138
" . . . . .166	" . . . . .164
Woodland . . . . .129	Townley . . . . .162
" . . . . .142	" . . . . .121
Roll . . . . .198	Thornbury . . . . .143
" . . . . .202	" . . . . .128
Woodward . . . . .130	Clifford . . . . .153
" . . . . .168	" . . . . .129
Thompson . . . . .136	Mangold . . . . .114
" . . . . .151	" . . . . .152
Woodward . . . . .118	Woodland . . . . .170
" . . . . .168	" . . . . .152
Roll . . . . .171	Thompson . . . . .169
" . . . . .183	" . . . . .150
Clifford . . . . .142	Townley . . . . .152
" . . . . .155	" . . . . .148

**Employes Help Their Needy Fellow Workers.**

The results from the circular of appeal to employes, sent out by the Jewelers' Relief Association, and published last week in THE CIRCULAR, are beginning to appear. The subscriptions received last week were:

Henry G. Lefort . . . . .	\$5 00
Pairpoint Mfg. Co. . . . .	25 00
Employes Albert Lorsch & Co. . . . .	17 00
" M. D. Rothschild . . . . .	13 00
" A. Wittnauer . . . . .	9 50
" Lissauer & Co. . . . .	20 50
" C. H. Knapp . . . . .	8 00
" H. Froehlich & Co. . . . .	4 50
" Jung, Staiger & Klitz . . . . .	10 00
" J. King Optical Co. . . . .	5 75
" Jos. Frankel's Sons . . . . .	5 00
" Keller & Untermeyer Mfg. Co. . . . .	12 00

\$135 25  
Previously acknowledged . . . . . 6,871 13  
Total . . . . . \$7,006 38



**Wm. L. Sexton Resigns the Secretaryship of the Jewelers' League.**

Members of the Jewelers' League of the City of New York, were surprised last week to receive notice of the resignation of Wm. L. Sexton, as secretary and treasurer of that organization, a position he has occupied for about fifteen years. The circular issued by the League reads as follows:

*The Jewelers' League of the City of New York, 170 Broadway.*

NEW YORK, March 2, 1894.

DEAR SIR:—At the regular monthly meeting of the Executive Committee held this day, the following communication was received:

NEW YORK, Feb. 12, 1894.

*Mr. Henry Hayes, President The Jewelers' League of the City of New York.*

DEAR SIR:—The interests of the League seem to demand that the position of secretary should be filled by one who can devote his entire time to its duties. This I cannot do, and notwithstanding my recent acceptance of a re-election, beg to tender my resignation. In addition to the regular duties incumbent upon the secretary, there will be increased demands owing to the consideration and possible adoption of a new class of membership. I beg leave to express my sincere appreciation of the uniform kindness shown me by the officers and members during my term of office.

Very respectfully,

WM. L. SEXTON.

On motion the resignation was accepted, and Mr. L. Stevens, Jr., was chosen to fill the office for the unexpired term. All remittances to be made payable to the order of, and communications sent to the Jewel-

ers' League of the City of New York, P. O. Box 930.

By order of the Committee,  
HENRY HAYES, President.

President Hayes stated to a CIRCULAR reporter that the notice issued by the League contained as full an explanation as he could give. Levi Stevens, Jr., who was appointed to fill Mr. Sexton's unexpired term, was



LEVI STEVENS, JR.

chosen, he said, because the executive committee believed him to be the man best fitted among those available for the position. His was the only name considered by the committee.

Levi Stevens, Jr., the new secretary, better known as "Col." Stevens, an appellation he has carried since childhood, is well-known to the trade. During his quarter century connection with this industry he has achieved a universal popularity that knows no abatement. He was born March 3, 1843, in Cay-

uga county, N. Y. He went to New York city in 1867, and has since been representing some jewelry house on the road. From 1867 to 1877 he represented Colby & Johnson; from that year to 1882, Wheeler, Parsons & Hayes, and from 1882, the firm of S. Albro & Co. until three years ago, when he joined forces with the Brooklyn Watch Case Co. On Jan. 1st, the current of year, he became salesman for the Keller & Untermeyer Mfg. Co., a position he left upon his appointment as secretary of the Jewelers' League. Mr. Stevens was married in 1873 at Fishkill-on-Hudson, N. Y., where his home has been since, his present homestead being particularly lovely. He has two children, a son and a daughter.

**The Jewelers' Security Alliance.**

The regular monthly meeting of the executive committee of the Jewelers' Security Alliance was held at the Alliance office on the 9th inst. at 10.30 o'clock A. M. There were present A. K. Sloan, president; Henry Hayes and David Untermeyer, vice-presidents; Bernard Karsch, treasurer; and Messrs. White and Abbott, and Geo. Hodenpyl, secretary.

The following were admitted to membership: W. Burr & Son, Carbondale, Pa.; Theo. Kartevold, 61 Hamilton Ave., Brooklyn, N. Y.; D. De Sola Mendes & Co., 51 and 53 Maiden Lane, New York; A. G. Crabbe, Hyndman, Pa.; C. G. Wock, Fort Plain, N. Y.; Chas. A. Harriman, Bath, Me.

**L. TANNENBAUM & CO.,**

IMPORTERS AND CUTTERS OF

**DIAMONDS • AND • PRECIOUS • STONES,**

Cor. Maiden Lane & Nassau St.,

NEW YORK.

25 HATTON GARDEN,  
LONDON.

TELEPHONE,  
Long Distance,  
1959 CORTLANDT



**SPECIAL ATTENTION!!** ♦ ♦ ♦ ♦

THE TRADE IS HEREBY NOTIFIED OF THE RETURN OF MR. L. TANNENBAUM, OF L. TANNENBAUM & CO., PER S. S. UMBRIA, ON SATURDAY LAST. HE SUCCEEDED IN PURCHASING, AT MARVELLOUSLY LOW FIGURES, WHAT IS PERHAPS THE FINEST AND LARGEST INVOICES OF PRECIOUS STONES EVER IMPORTED.

IT COMPRISES AMONG OTHER THINGS, SOME

Very Fine Oriental Rubies of various sizes, specially Fine Ruby Stars, Extra Opals, Fancy Diamonds, Superlative Blue White Diamonds, Fine Olivines and Particularly Fine Small Melec all sizes.



TO TURN THESE GOODS INTO CASH THEY WILL BE OFFERED AT PRICES EVEN MORE SURPRISING THAN THE BARGAINS WHICH HAVE BEEN REGULARLY ADVERTISED BY THE FIRM ON THIS PAGE. AN INSPECTION OF MR. TANNENBAUM'S PURCHASES WILL BE SURE TO PAY, EVEN IF AT THE MOMENT YOU MAY NOT BE IN NEED OF ANY GOODS,





**Last Week's Arrivals.**

*THE CIRCULAR has perfected arrangements for obtaining the names and hotel addresses of all the latest buyers visiting New York, and each day posts in its office, 189 Broadway, a bulletin which every member of the trade is cordially invited to copy.*

The following out-of-town dealers were registered in New York during the past week: Chas. Rochat, Smith & Murray, Springfield, Mass., 55 White St.; Mrs. J. C. Nourse, Woodward & Lathrop, Washington, D. C., 415 Broadway H.; F. M. Tobin, Chicago, Ill., Sturtevant H.; W. Maynard, Boston, Mass., Cosmopolitan H.; C. M. Upson, Waterbury, Conn., Murray Hill H.; G. A. Wells, Wilkesbarre, Pa., Astor H.; E. T. Allen, Minneapolis, Minn., Imperial H.; L. Hahn, New London, Conn., Grand Union H.; L. Atkinson, Philadelphia, Pa., Astor H.; G. A. Lee, Toronto, Ont., Astor H.; W. Macey, Altman & Co., Buffalo, N. Y., Imperial H.; A. Zugsmith, Philadelphia, Pa., St. Denis H.; A. Zinn, Milwaukee, Wis., Belvidere H.; T. J. Mooney, buyer for J. Wanamaker, Philadelphia, Pa., Astor H.; J. E. Cahill, Boston, Mass., Cosmopolitan H.; W. B. Durgin, Concord, N. H., Holland H.; J. Harth, Danbury, Conn., Grand Union H.; J. E. Ladd, Bristol, Conn., Astor H.; G. W. Fairchild, Bridgeport, Conn., Grand Union H.; J. Schlenker, Buffalo, N. Y., Sinclair H.; H. Weil, Buffalo, N. Y., Imperial H.; C. S. Davis, Philadelphia, Pa., Astor H.; W. H. Hansell, Philadelphia, Pa., Astor H.; D. Horne, Pittsburgh, Pa., Imperial H.; L. Emery, Jr., Bradford, Pa., Imperial H.; J. P. Rule, D. McCarthy & Sons, Syracuse, N. Y., Grand Union H.;

A. Schaub, Detroit, Mich., St. Stephens H.; A. Eaves, Montreal, Que., Astor H.; C. D. Tucker, Worcester, Mass., Astor H.; L. G. Weil, Pittsburgh, Pa., Astor H.; O. E. Bell, Cincinnati, O., Broadway Central H.; J. Mitchell, Toledo, O., Astor H.; J. M. Harper, Philadelphia, Pa., Astor H.; M. Frank, Danville, Va., New York H.

**A Sensational Development in the Affairs of the Chas. Jacques Clock Co.**

The controversy between the Charles Jacques Clock Co., New York, and their former president, Chas. A. Jacques, was given a new turn last week when the directors of the company caused the arrest of Mr. Jacques on the charge of fraudulently issuing evidence of debt of that concern. When arraigned in the Tombs Police Court, Thursday, Mr. Jacques was held in \$3,000 bail for examination, which was set down for yesterday.

Mr. Jacques was deposed from the presidency of the company at a meeting of the directors, March 2d, and the company issued a circular to that effect. Mr. Jacques then made application to the Chancellor of New Jersey and obtained an order to show cause why a receiver should not be appointed for the company, which is a New Jersey corporation. The motion was set down for argument on Monday. The company then caused Mr. Jacques' arrest, claiming that he had, while president, without authority, given a chattel mortgage to the Chatham National Bank.

Mr. Jacques stated that he had given the chattel mortgage but had full authority to do so. The bank, he said, held two notes of the company aggregating \$3,500, indorsed by him and Mr. Harrington, another director. Wishing to be relieved as security, he said, he requested the directors to take measures to secure the bank, and his suggestion was adopted he said at a meeting

on Feb. 27th. Then Mr. Jacques said, he learned that he was to be deposed from the presidency, and after consulting with the president of the bank, gave a chattel mortgage to secure the notes. He claims that as president of the company, he had full authority to do this.

**An Interesting Suit Over a Safe.**

LYNCHBURG, Va., March 7.—A case of more than ordinary interest was heard the past two days in the Corporation Court. It was a suit of E. A. Williams, jeweler, against B. F. Smith, of Richmond, dealer in Hall's safes. The points of the suit were as follows: In 1890 Mr. Williams bought of Smith a fire and burglar-proof safe, represented to be Hall's first-class burglar-proof work, with all of the latest improvements, for which he paid \$400. Some time since the lock on the inside on the burglar-proof doors became out of order, and Mr. Williams could not get his goods out.

Being in a quandary what to do, he called to his aid Chas. Hicks, a local machinist, who also tried the lock, but could not do anything with it. Mr. Hicks then went to work with his ordinary tools and cut the door open in a short time. Mr. Williams thereupon brought suit for damages, praying that inasmuch as Mr. Hicks opened the safe with no special tools the safe was in no wise burglar-proof. Yesterday the jury reported that they had failed to agree, it being understood that they were undecided whether the suit should have been brought against Mr. Smith or the safe company.

The case will now be postponed until the April term of the court.

George Bowers, Lyndon, Kan., had his stock attached March 9 by a St. Louis wholesaler's firm. It is said his liabilities are about \$600 and that his assets are insufficient to cover this amount.

**WE DO NOT CLAIM THAT OURS ARE THE "CHEAPEST" OR THE "LIGHTEST WEIGHT" GOODS IN THE MARKET, BUT WE STILL ASSERT THAT OUR STERLING SILVER BELTS ARE UNRIVALED IN LOW PRICES, EXCELLENCE OF FINISH AND ARTISTIC CONCEPTION.**

Any shade of MOIRE ANTIQUE Webbing furnished when desired, at same price.

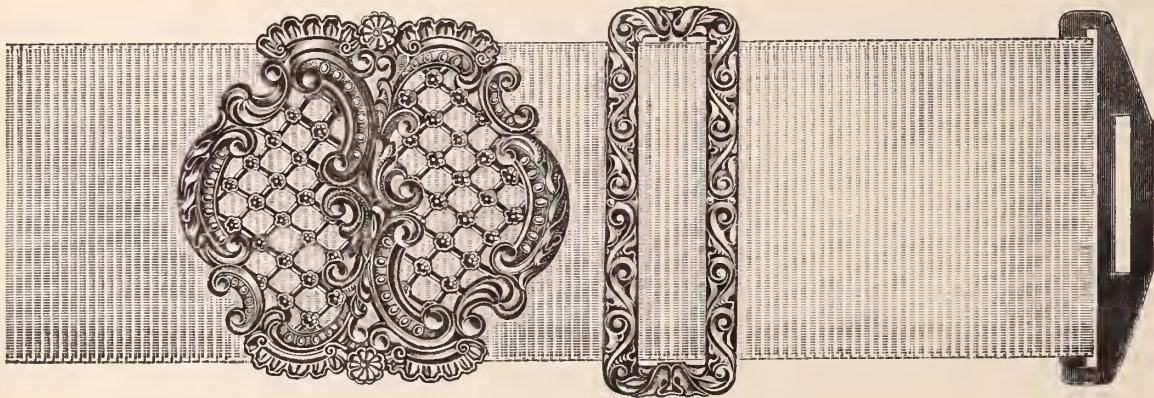

ANY, AND ALL KNOWN SHADES OF WEBBING FURNISHED.

**\$1.50 [FOR THIS BELT COMPLETE.]**

Bright-Cut STERLING Silver (no filling), Mounted on Highest Grade of Imported Silk Webbing. An endless variety of patterns,

**JNO. W. REDDALL & CO.,**

**107 HAMILTON ST., NEWARK, N. J.**

Fourteen Karat Gold and Sterling Silver Goods of superior make and finish, at saleable prices,



**Providence.**

**NOTICE:**—As the authorship of the article entitled "The Jewelry Industry," which appeared in the Providence Journal of March 5th, and which has caused considerable feeling among the trade, has been ascribed to the correspondent of THE CIRCULAR, Wm. H. Mason, for no other apparent reason than that he is an attache of the reportorial force of the Journal, we take this opportunity to notify the trade that he was not its author; and that we feel assured that his interest in the trade, by reason of his connection with THE CIRCULAR would prevent him from being responsible for the publication of any unnecessary item, having a baneful tendency on the progress of the jewelry business.

E. Fairbrother has severed his connection with W. S. Hough, Jr. & Co.

W. C. Weiner, of Weiner Bros., New York was in town the past week.

Homer M. Daggett, Jr., has mortgaged real estate in Pawtucket for \$2,000.

F. W. Mowry has started in the retail jewelry business at 174 Weybosset St.

Horace W. Steere, of Arnold & Steere, is making an extensive trip through the west.

Charles Bloomer, of C. G. Bloomer & Sons, is convalescing from a recent attack of diphtheria.

Charles Holmes, of the Standard Seamless Filled Wire Co., Pawtucket, was in New York last week.

Fred Mooney, of this city, is representing Julius Eichenberg at the Mid-Winter Exposition, San Francisco.

William R. Dutemple has been elected vice-president of the Auburn Free Public Library Association.

M. Bonn, Pittsburgh, Pa., was among the recent visitors who called upon the local trade in quest of new goods.

Dutee Wilcox has purchased valuable real estate on Mathewson St., also at the corner of Washington and Aborn Sts.

William L. Slade, of Slade & Whipple, of Attleboro, is slowly convalescing at his home in this city, after a serious illness.

William E. Petty and Albert Donahue have discharged a chattel mortgage of \$285.14 on their store at 256 N. Main St.

Abram Crowell has given a chattel mortgage on tools and machinery in the shop at 66 Clifford St. to Emma H. Tuttle, for \$600.

Byron N. Harris, for many years stone-setter for S. K. Merrill & Co., died recently at Lake View Highlands Hotel, Florida, of consumption.

The Kent & Stanley Co. have mortgaged real estate on northeast corner of Aborn and Sabin Sts. to Harold Brown, of Newport, for \$15,000.

The Standard Seamless Wire Co., Pawtucket, have given a real estate mortgage

of \$12,000 on property in Lincoln and \$8,000 on property in Pawtucket, both to the Woonsocket Institution for Savings.

The magnificent gold medals given for competition to the enlisted men of the brigade, Rhode Island militia, by Gov. D. Russell Brown, Sur.-Gen. Budlong, Mayor Potter, Adj-Gen. Dyer; also the beautiful silver ones given by the State for qualifications for sharpshooters and marksmen, have been finished by Lieut. Lewis Pastone, of Pastone & Co., the makers.

**A Bill to Regulate the Sale of Silverware.**

PROVIDENCE, R. I., March 6.—In the General Assembly to-day an act was introduced to regulate the sale of silver, which was referred to the Senate Committee on Judi-

ciary. Later in the day this bill was brought up in committee meeting for consideration, but was returned for amendment as there was no penalty attached.

This bill was introduced, it appears, at the suggestion of the Gorham Mfg. Co., and provides that all goods marked "Sterling" or "Sterling Silver," shall contain not less than 92.5 per cent. of pure silver; and all goods marked "Coin" or "Coin Silver," shall contain not less than 90.1 per cent. of silver; and that the offering for sale of any goods not up to these standards shall be a misdemeanor.

Oyde Gaskell and John Mickelson, two lads aged 12 years, were arrested last week in La Crosse, Wis., charged with robbing H. S. Singh's jewelry store.



**\$3.00**      **FORMERLY**      **\$6.00**

Ivory and Enamel Miniatures

Best Workmanship.

Original Inventor and Patentee of Miniatures —OR— Gold and Silver.

PATENTED November 12, 1889.

**LEON FAVRE,**      107 E. 26th Street.      New York.

**ESTABLISHED 1870.**

**J. L. CLARK,**

**SWEEP SMELTER AND REFINER OF GOLD AND SILVER.**

Buys every kind of Gold and Silverware, Jewelry, Watches and Platinum. Full market value paid.

**No. 724 Filbert Street, Philadelphia, Pa.**

SEND BY EXPRESS or Registered Mail. If my price is not satisfactory, I will return all articles.

<p>A Full Line OF ALL <b>AMERICAN</b> <b>WATCHES.</b></p>	<p><b>MAX FREUND &amp; CO.,</b> Importers of Diamonds and Precious Stones, AMSTERDAM: 8 MAIDEN LANE, TULPSTRAAT 9.      <b>NEW YORK.</b></p>	<p><b>SPECIALTY:</b> <b>DIAMOND</b> <b>JEWELRY</b> of our own design.</p>
---	--	---



# FOR EASTER BOOK MARKS

IN STERLING SILVER.

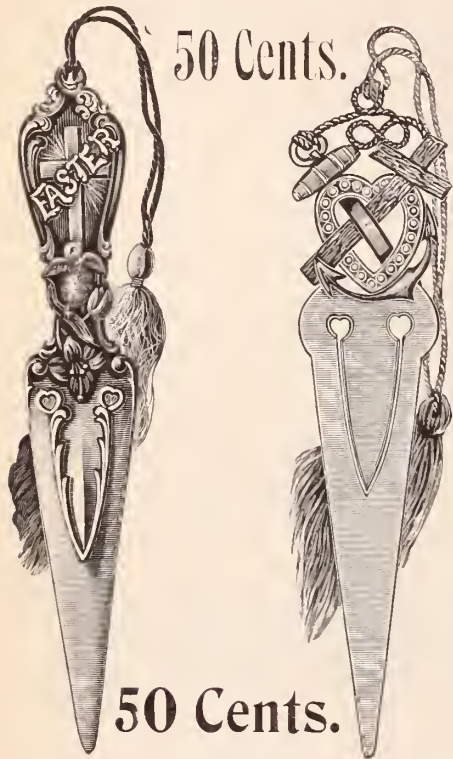

ALVIN MFG. CO.,  
...SILVERSMITHS...

860 Broadway, = = New York.

## Paper Boxes

At Prices Which Defy  
Competition.

Plain and Fancy Silverware Boxes  
FOR MANUFACTURERS USE  
OUR SPECIALTY.

Our large dealings in Satins, Silks and Sateens in the Corset Business, together with special machinery, enable us to do the BEST OF WORK AT LOW PRICES. Quotations promptly furnished upon receipt of sample.



Address

Warner Bros.,

Bridgeport, Conn.

Box Department.

### MORE APPRECIATIVE COMMENTS

#### ON THE SILVER ANNIVERSARY OF THE JEWELERS' CIRCULAR.

It is proper, and we do it with genuine pleasure, to congratulate THE JEWELERS' CIRCULAR on the anniversary of its twenty-fifth year. It is nothing to have lived long, but to have lived well and to have accomplished high aims, all this belongs to THE CIRCULAR's record, and it is very proper to celebrate the event by a silver edition. In it the advances in timekeepers is told by skilful writers, and its well printed pages mark well the growth in a sister art.—*The Waterbury.*

Your silver anniversary is an artistic gem. Will show it to every customer on the road.  
FLINT BOWEN,  
Kansas City, Mo.

Congratulate you upon the beauty of your twenty-fifth anniversary number.  
SAMUEL J. SCHLESS,  
Wilmington, Del.

It is with more than ordinary pleasure that we congratulate you upon the occasion of your silver wedding and refer to the interesting and artistic souvenir number of

your CIRCULAR, which was issued to commemorate the occasion. May the success of the last quarter of a century continue uninterrupted is the sincere wish of a continuous subscriber. Very sincerely yours,  
THE GEO. H. FORD CO.,  
New Haven, Conn.

The silver anniversary number is a dandy.  
S. J. RUGG,  
Toronto, Can.

Your silver JEWELERS' CIRCULAR pleased me very much, and accept my congratulations on your success.  
A. STAIB,  
Baltimore, Md.

The silver anniversary number of THE JEWELERS' CIRCULAR proved to be an exceedingly interesting paper. The contents, varied and attractive, were judiciously laid out between advertisements, and as an achievement of its kind is entitled to rank with any effort previously made by this old and reliable journal.—*The National Retail Jeweler.*

## THOMAS W. LIND, Manufacturer of Jewelers' Findings,

67 FRIENDSHIP STREET, PROVIDENCE, R. I.



FULL SIZE NEW ROCOCO.



Settings Made in Any Desired Thickness of Stock.

Call or send for samples of my New ROCOCO PATTERNS, for Picture Frames, Cane Heads, Whips, Boxes, Napkin Rings, etc.

Large Assortment of TRIMMINGS for Millinery Ornaments, Scarf Pins, etc



**Connecticut.**

W. S. Rowe, New Haven, is out again after a severe illness.

W. F. Paddock, jeweler, Bridgeport, has decided to change his business to optical goods only.

E. M. Beckwith, a jeweler from Northampton, has located in business in Torrington.

Ex-Collector of the Port Wm. H. Saxton, jeweler, New London, has sold his place of residence at auction for \$4,654.

N. E. Gladwin, Essex, has purchased the building in which his jewelry store is located and is having it improved.

The Middletown Plate Co. have started to work a full force of hands on a schedule of ten hours a day, four days a week.

Cephas Rogers, of C. Rogers & Bros., Meriden, has been re-elected president of the Connecticut Morrell Liquor Cure Co.

The application recently made for the appointment of a trustee over the estate of Gould & McKeon, jewelers, Bridgeport, has been dismissed by Judge Tallmadge in the probate court.

A fire in the blower's pit of the Holmes & Edwards Silver Co.'s shop, Bridgeport, last week, caused slight damage. It was extinguished by the steam pump and chemicals belonging to the company.

Corporation returns: Chapman Mfg. Co., Meriden, capital \$25,000, real estate, \$20,000, personal estate, \$42,000, debts, \$48,000, credits, \$55,000; Wm. Rogers Mfg. Co., Hartford, capital, \$25,000, personal estate, \$168,397, debts, \$99,792, credits, \$52,285.

In the superior court in New Haven last week F. Silverthau appeared as the plaintiff in a suit brought against the estate of Henry S. Sawyer, of Derby. The suit is brought to recover \$333, the amount of a jewelry bill incurred by Robert Sawyer, a grandson of the deceased. Mr. Sawyer left an estate of \$228,000 and his grandson is one of the heirs.

Judge Hubbard presided at the special town meeting in Wallingford last week called for the purpose of abating the taxes for ten years asked for by Noah Linsley and E. C. Valentine, who represent a proposed organization desiring to locate there and build a factory for the manufacture of silver plated ware. The request was granted without opposition.

**Switzerland Parties Sue the Columbus Watch Co.**

COLUMBUS, O., March 9.—The Columbus Watch Co.'s recent trouble is still slowly coming into court. F. F. D. Albery has brought four suits for parties living in Switzerland, who furnished watch springs and other materials.

The full amount of the suits is \$11,378.45. Accompanying their petition is a certificate from John E. Hismen, the United States vice consul, stating that the bills sued on are according to the books of the plaintiffs in Switzerland.

**THE BOWDEN SEAMLESS RING**

IS MADE ONLY BY

**J. B. BOWDEN & Co.,**

Makers of Finger Rings of every Description.

**COR. BROADWAY & JOHN STREET,**

NEW YORK.

**DIAMOND EXCHANGE BUILDING.**



In the new fire proof, ten story

Diamond Exchange Building,

14 Maiden Lane.

**OFFICES**

of most modern construction, with abundance of light and air, rapid elevator, mail chute, steam heat, gas and electric light, exposed sanitary plumbing, oak cabinet trim, unique plate glass partition and quartered oak floors, at rentals from

**\$900.00**

Per Annum up.

Specially adapted for the Diamond and Jewelry Trade. Possession on or before May 1st, next.

For further particulars apply to

**E. A. Cruikshank & Co.,**

176 Broadway, N. Y.

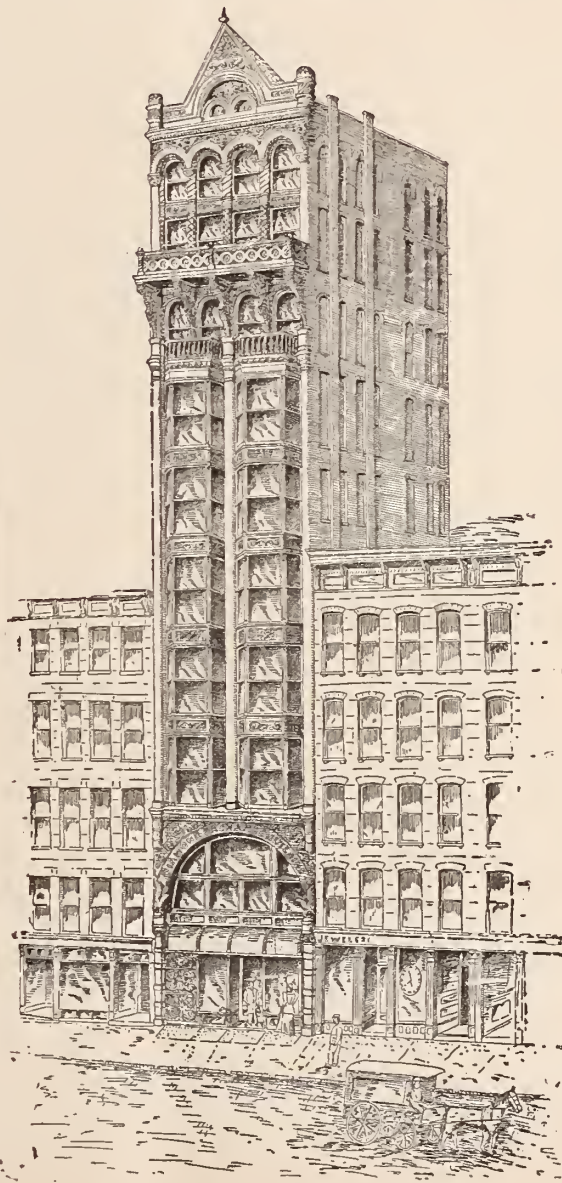

**THE ELEVATOR IS NOW RUNNING.**



THE STATE OF ILLINOIS WESTWARD TAKES ITS WAY

# WESTERN SUPPLEMENT

## of THE JEWELERS' CIRCULAR

Chicago Office: Room 308, Inter-Ocean Building.

VOL. XXVIII.

CHICAGO, WEDNESDAY, MARCH 14, 1894.

No. 6.

### Chicago Notes.

Robert Hallex, for the past 10 years with L. F. Hussander, has opened a store at 898 N. Halsted St.

L. T. Hussander, for 20 years located at 22 and 58 N. Clark St., will remove May 1st, to 106 N. Clark St.

Mrs. Matt Hibbeler, wife of the jeweler at 195 Center St., has presented her husband with a 14 pound boy.

W. H. Beck, Sioux City, Ia., swept into town with a western zephyr last week. Mr. Beck is a welcome visitor.

The Chicago Watchmakers' Institute is increasing its number of pupils monthly. The school will double its present room space May 1st.

Mr. Sommer, of Sommer & Pierik, Springfield, Ill., has disposed of his interests in the firm to Mr. Pierik. The firm name will not be changed.

The handsome tool and material catalogue of Benj. Allen & Co., larger and better than ever, with prices revised and all new tools up to date, will be issued the present week.

President Thomas, of the Manhattan Silver Plate Co., was in the city a few days on his way to join Mrs. Thomas at Colorado Springs, Col., and contemplates a California trip before his return.

H. C. Kracker, 775 Milwaukee Ave., is embellishing the front of his jewelry store for Spring trade and has just hung over the entrance of the store one of Grout's Excelsior wedding ring signs.

C. T. Wittstein has returned from a month's trip of combined business and pleasure on the Pacific coast. "Trade there is quiet," said he, "but I more than paid expenses and laid the foundation for some good business later on."

The Manhattan Silver Plate Co. have lately put in an electric light plant in their factory at Lyons, N. Y., for night work, and expect shortly to increase their transportation facilities by building a railroad from the factory to the main line.

A partial list of buyers in Chicago last week includes: J. W. Quinn, Oconomowoc,

Wis.; O. Rose, Crown Point, Ind.; W. H. Beck, Sioux City, Ia.; J. P. Foss, Oconomowoc, Wis.; E. P. Copp, Madison, Wis.; T. B. Myers, St. Paul, Minn.; Mr. Pierik, Springfield, Ill.

In dull times every avenue for securing business is availed of by wide-awake jewelers, and the establishment of an optical department should not be overlooked in this connection. Those who have recently established these departments pronounce them money-makers.

The Brooklyn Watch Case Co. have withdrawn from the Chicago Jewelers' Association. This was brought about by the consolidation here of the Brooklyn company with Jos. Fahys & Co. Fahys & Co. being a member of the association it was deemed unnecessary to carry two memberships.

The Geneva Optical Co. report order trade looking up and the prescription business increasing steadily. The order and prescription trade are branches the company have given much attention to, and the results are due to well directed effort. The factory at Geneva, N. Y., is running on full time.

The street fakirs and peddlers of bogus jewelry are discountenanced by Wisconsin State law. J. W. Quinn, a jeweler of Oconomowoc, one of the State inspectors to unearth these frauds, recently had one of the gentry sent to the penitentiary for a year for selling brass spectacles which he represented to be gold. A law of this sort is needed in every State.

A. I. Agnew, formerly with the Geneva Optical Co., left for Europe the latter part of the week on a "business vacation," and incidentally will examine into the advanced science in optics as shown by leading houses on the Continent. Mr. Agnew will visit all the larger cities and will remain in Europe from six months to two years.

L. Newhouse, of Glickauf & Newhouse, the tool and material men, returned Wednesday from an extended trip in Iowa, Minnesota and Wisconsin. He says the merchants all look for a revival with the opening of Spring, and reports fair trade during his entire trip. No large bills were

sold, but everywhere the stocks were low and required a sorting up.

The ceilings and walls of the salesrooms of Schauweker & Chalmers, Venetian building, are being decorated. An additional safe was placed in position, the private office removed to the south side of the room and a burglar alarm system added for the protection of their watch stock. The firm lately succeeded to the business of Chas. Glatz, as jobbers of watches.

At the regular monthly meeting of the Chicago Jewelers' Association, March 6, an important matter to the trade was brought up. This was the subject of memorandum bills. After informal discussion it was decided to obtain the opinion of a first class commercial lawyer as to the value of memorandum bills in this State, and as to what constitutes a conditional sale.

The Bolstad Mfg. & Plating Co., 170 Madison St., report a strong and varied improvement in business since the first of the year. The firm are well equipped with a fine plant of improved machinery for the manufacture and repair of watch cases and have a corps of able workmen. Plating of cases is a specialty of the firm, and their process of "inlaying" is receiving much attention. By a device of Mr. Bolstad's invention, an exact reproduction of design is plated on the case instead of the costly inlay work proper.

William E. Fleissner, formerly a jeweler with good commercial rating at Manistee, Mich., wrote Elmer A. Rich, Chicago, manager for Alfred H. Smith & Co., for diamond rings valued at \$125. The goods were forwarded to Manistee, but in the meantime Fleissner had gone to Milwaukee, Wis., and the goods were re-forwarded there. The letter, it seems, was written by Arthur Sherman, who does more or less brain work for Fleissner. On receipt of the diamonds Sherman and Fleissner disposed of them in Milwaukee pawnshops. Mr. Rich, learning this, had both parties arrested on the charge of obtaining goods upon false pretenses, and they were brought to Chicago where they are now in jail. The case will be brought up on the 16th inst.



A. C. Becken will return from his southwestern pleasure trip the present week.

F. M. Sproehnle, wife and child, departed March 6th on a three weeks' pleasure trip through the south.

Mr. Loeb, Chicago manager for the Wadsworth Watch Case Co., smiles over the results of a business campaign in the Twin Cities the past week.

Bert Allen, connected with Alfred H. Smith & Co.'s Chicago branch, is again at the diamond rooms nearly recovered from a three weeks' attack of inflammatory rheumatism.

**O. W. Wallis Becomes Sole Owner of O. W. Wallis & Co.**

CHICAGO, Ill., March 10.—O. W. Wallis has purchased the outstanding interests in the firm of O. W. Wallis & Co., from Wm. Smith & Co., his former partner, and now has complete control of the business which he has for the past 14 years so successfully managed. The purchase by Mr. Wallis covers all interests in the stock of merchandise, fixtures, books of account, accounts receivable, bills receivable and all other property and effects including the good will of the business.

Mr. Wallis will continue to give the business his personal attention in the interests of his customers. As in all reorganizations, the house has many special bargains that the trade are not likely to overlook.

The firm of O. W. Wallis & Co. was established in 1869 on Lake St. as Cogswell & Co.; in 1871 they were succeeded by Cogswell, Weber & Co.; in 1879 by Cogswell & Wallis, and in 1889 by O. W. Wallis & Co. The present firm was incorporated March 6, 1893, as O. W. Wallis & Co. They are wholesale dealers in diamonds, watches and jewelry, and have been in the business for nearly 20 years.

On May 1, 1893, the firm moved from 96 State St., to their present quarters in the Columbus Memorial building, southeast corner State and Washington Sts. There is an added activity about the salesrooms already apparent.

**Provisions of the Will of Sebastian Andersen.**

CHICAGO, Ill., March 9.—The will of Sebastian Andersen, late president of the Juergens & Andersen Co., was filed for probate March 6th. The property goes to the widow, who has appointed Paul Juergens as administrator. The meeting of stockholders of the Juergens & Andersen Co. has not yet been held, but it is definitely announced that Will G. Andersen will acquire the interests in the firm held by his father and will assume the presidency of the company, the office of vice-president which he formerly held, being abolished.

Besides the real estate and other property which Mr. Andersen had previously to his death given outright to his wife, there are \$207,000 in bonds and securities, including the stock of the firm, and \$50,000 worth of real estate. The daughter will be provided for from the mother's share of the estate and the balance divided between the two sons, William G. and Julius P., the former securing his father's share in the business as part of his share, the latter receiving bonds and real estate.

The Chicago Jewelers' Association, in ses-

sion March 6th, passed the following resolutions:

Death has again invaded our ranks and removed from our midst a most worthy and respected associate.

For more than 40 years Sebastian Andersen was an honored citizen among us. He always held a high place in the community and in his profession.

By his zeal and his exemplary life he reached the zenith of his calling; his manly presence and even temperament inspired confidence in every one who knew him.

His heart knew no guile in life; his soul needs no fear in death. Therefore

*Resolved*, That the Chicago Jewelers' Association deplores the death of our friend and fellow member, Sebastian Andersen, and we will cherish the memory of his valued companionship.

*Resolved*, That we extend to his family our sincere condolence and present them a copy of these resolutions, and that the same be entered upon our records.

H. F. HAHN,  
A. HIRSCH,  
BENJ. ALLEN,  
M. ELLBOGEN,  
J. SCHNERING, Committee.

It was ordered that the resolutions be engrossed in book form and be signed individually by every member of the association.

A bill of sale was recorded Wednesday for jewelry, etc., at 6203 Commercial Ave., Chicago, E. Keller to C. Leselberg, the consideration being \$31.

**OPTICAL DEPARTMENTS ESTABLISHED.**



AN EXPERT OPTICIAN will thoroughly establish an Optical Department in a limited number of FIRST CLASS JEWELRY STORES, giving his own time as promoter until on a successful basis. Will also give complete instructions in fitting to the man designed as head of the department.

**THERE'S MONEY IN IT.**

Jewelers wishing to make a special run in their optical department or establish one, will find this a rare opportunity. Your business can be increased \$1,000 to \$2,000 a month. Arrangements can be made either on percentage or salary. An unusual opportunity for a good house to

**ENTER A LUCRATIVE FIELD.**

ADDRESS

**OPTICIAN, Care JEWELERS' CIRCULAR, Chicago Office,**

**308 INTER-OCEAN BUILDING, CHICAGO.**

**LOOK OUT**

For our new illustrated Tool and Material Catalogue of 464 pages. It is the largest and most complete catalogue ever issued. We have made many substantial reductions in prices, and can meet the wants of every Jeweler desiring the best goods at lowest possible prices.

... WATCH FOR IT ABOUT MARCH 15TH. ...

Should you fail to receive a copy, notify us and we will be pleased to send you one.

**BENJ. ALLEN & CO.,**

**WATCHES, DIAMONDS AND JEWELRY,**

141 AND 143 STATE STREET,

CHICAGO, ILL.



# "Best" Eye Glasses.

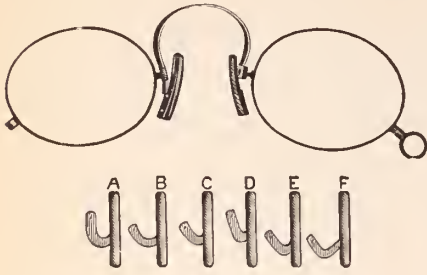

The "BEST" Guard embodies some new features of great value. The lower part is rigid, the upper part is flexible. Made in both shell and cork. Must be seen to be appreciated.

Sample Eyeglass Frame, in 10k. gold,	-	-	\$2.90
" " " " in Steel or Nickel,	-	-	.35
Sample Pair of 10k. Gold Guards,	-	-	.85
" " " " of Nickel Guards,	-	-	.15

**Geneva Optical Company,**  
69 WASHINGTON STREET,  
CHICAGO.

## CHAS. H. PFEIL, MANUFACTURING JEWELER. Diamond Work a Specialty.

**BEST of Workmen.  
BEST Design Work.  
GUARANTEED Workmanship.**

Send a trial order and be convinced.  
**182 State St., Chicago.**

**HUGO MUELLER,**  
182 State St., (Room 70,) Chicago.  
**FINE WATCH REPAIRING**  
IN ALL ITS BRANCHES.

Work for the trade promptly executed by skilled workmen.

**PARSONS : SCHOOL**  
—FOR—  
**WATCHMAKERS,**  
PEORIA, - - - ILL.

Send for Circular and Terms.  
**PARSONS & CO.**

WATCH CASE MAKERS AND REPAIRERS.  
**BOLSTAD MANUFACTURING**  
**AND PLATING CO.,**  
GOLD AND SILVER PLATERS.  
DESIGNING AND ENGRAVING.  
170 Madison Street, - - CHICAGO.

**ELGIN HOROLOGICAL SCHOOL,**  
THOROUGHLY PRACTICAL.  
COMPETENT INSTRUCTORS.  
Send for Prospectus.  
**ELGIN, ILL.**

### The Supreme Court Affirms the Verdict in Mrs. Barr's Suit.

KANSAS CITY, Mo., March 10.—The Supreme Court has affirmed the verdict of \$10,000 damages to Mrs. Carrie A. Barr, of the Barr Jewelry Co., given her by the Circuit Court in her suit against the corporation of Kansas City.

While crossing a street six years ago, Mrs. Barr stepped upon the insecurely fastened covering of a sewer opening, and fell to the bottom, a distance of six feet. In affirming the judgment Judge Black, of the Supreme Court said that while the amount is unusually large the evidence of permanent injury sustains it.

### The Robbers Jumped Through the Plate Glass Window.

WICHITA, Kan., March 8.—Two men entered W. W. Pearce's jewelry store on Douglas Ave., one of the most public places in the city, at six o'clock last evening, when no customer was in the store, and, holding the proprietor up, proceeded to help themselves to jewelry and gold watches. A watchmaker, who was working behind a high showcase and who was not noticed by the thieves, coolly stole up to the front door and locked it and then turned on the burglar alarm.

The tingle of the alarm warned the robbers, and finding the door locked they escaped with the booty by jumping through a plate glass window, 3/8 inch thick. One of the robbers was captured in the pursuit and

made a terrible fight. Valuable diamonds and necklaces were found hidden under his shirt, he having slipped them down the back of his neck. He gave his name as John Locke. The police believe him to be a noted criminal. The other robber escaped.

### Kleeman Bros. Again Prominently Figure in Court.

COLUMBUS, O., March 10.—The Messrs. Kleeman and the Union Jewelry Co. this week filed their answer in the suit brought by Julia Jones to recover about \$1,100 for jewelry which she claimed William Kleeman took from her on the representation that he wanted to show the diamonds to his brother-in-law. The answer shows that plaintiff on Nov. 17, 1892, owed the jewelry company \$701.72. The contract under which she had bought the goods called for a payment of \$50 per month. On July 31, last, the bill for above amount was presented to her and she could not pay it. Defendants allege that she then agreed to let them have the diamond bracelets and earrings and the watch to pawn to Abram Ramsfelder for \$600, which was to be credited on the account and she was to pay him \$50 per month and 8 per cent. interest.

A few days later she came to the store and asked for the watch and defendants went and got it, returning \$50 of the money to Ramsfelder. This left a balance due of \$151.72, which Miss Jones still owes.

## NOTICE . . .

Mr. O. W. Wallis, having purchased all the rights and interests formerly held by Wm. Smith & Co. in the firm of O. W. Wallis & Co., Agents, the business will be continued by him, under the firm name of O. W. Wallis & Co. at the old stand, 103 State Street, Chicago.

Our rearrangement of stock enables us to offer many special bargains, which will be money-makers for you. Everything required by wide-awake Jewelers, can be found in our complete stock of

**DIAMONDS, WATCHES AND JEWELRY,**  
and unheard-of bargains in numerous short lines.

Thanking the trade for their liberal patronage of the past, we look—with our greater advantages—for continuance of same.

**O. W. WALLIS & CO.,**

Wholesale Jewelers,

COLUMBUS MEMORIAL BLD'G. 103 STATE STREET, CHICAGO.

## PATENT FIBRE-FACED HAMMERS.

5 oz. for Watchmakers.  
10 oz. for Manufacturing Jewelers.  
Price 50 Cents Each.

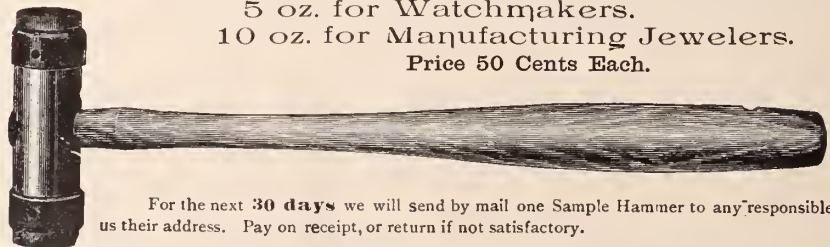

For the next 30 days we will send by mail one Sample Hammer to any responsible firm giving us their address. Pay on receipt, or return if not satisfactory.

**W. W. OLIVER, Sole Manufacturer, - Buffalo, N. Y.**

Send for our No. 10 Catalogue.

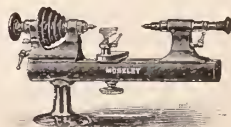

One of the best of the very best.

QUALITY IS THE STANDARD OF VALUE.

CHARGES TO SUIT THE TIMES.

When interested, write your jobber for new price list for 1894, or

**Moseley & Co., Elgin, Ill.**



No. 2 Moseley Wire Chuck has length, strength, accuracy.



**Minneapolis and St. Paul.**

O. Rystad, Grand Forks, N. Dak., whose place of business was recently destroyed by fire, was in Minneapolis the past week purchasing a new stock of goods.

M. Weinstein, Minneapolis, has sold out his business to S. B. Abel, who will continue it at the old stand, 107 Washington Ave. S. Mr. Weinstein, with his family, will move to New York city, where he contemplates starting in business again.

The Reed & de Mars Jewelry Mfg. Co., Minneapolis, last week removed from their old stand at 219 Nicollet Ave. to rooms 415 to 418 Lumber Exchange building, fourth floor, corner 5th St. and Hennepin Ave. The building is one of the finest in the northwest.

W. S. Ankeny, assignee for Harry F. Legg, Minneapolis, who assigned some months ago, made his final accounting to the court last week, and was discharged. The creditors who filed their claims received 20 cents on the dollar, in full settlement. The estate is now closed up.

Henry Birkenhauer, who for a number of years prior to Feb. 1, 1893, represented the Reed & de Mars Jewelry Mfg. Co. in the Twin Cities as city salesman, and who resigned his position at that time, has accepted a position with this firm as city salesman and buyer for the material, tool and findings department.

**Pacific Coast Notes.**

"Wagner the Jeweler" has opened a store at 158 N. Main St., Los Angeles, Cal.

Aluminum is in active demand in San Francisco just now, it being made into souvenir pieces of the Mid-Winter Fair.

A. O. Solberg has opened a jewelry business in the Everett Drug Co's store, with a fine line of jewelry. Mr. Solberg was lately foreman in one of the departments of the Elgin watch factory.

One of the concessionaries at the Mid-Winter Fair has instituted suit against the management, claiming that he paid for the exclusive right to sell silver and gold plate in the main building, but finds plenty of competition in his preserve.

Col. Andrews, San Francisco, is spoken of as the next candidate for mayor on the Democratic ticket. The Colonel has been very prominent in the financial management of the Mid-Winter Fair, and is a popular man among society people and in military circles.

The Golden Rule Bazaar, on Market near Kearney Sts., which handled a big stock of jewelry, was entirely consumed by fire some nights ago. The fire is supposed to have been caused by imperfect insulation of electric light wires. The buildings were owned by the famous Blythe estate, so long in litigation, and are located in the very heart of the business center. In addition to the Bazaar's jewelry stock the store of Chas. Fink, jeweler, was damaged.

**REED & BARTON,  
SILVERSMITHS,**

MANUFACTURERS OF

**STERLING SILVER *and* SILVER PLATED WARE.**

SALESROOMS:

**37 Union Square, New York.**

34-36 WASHINGTON STREET,

**Venetian Building, Chicago.**

FACTORIES, TAUNTON, MASS.

... THE ...

**American Horological Institute**

AND TECHNICAL SCHOOL OF LANCASTER, PA.,  
LATE OF PHILADELPHIA, PA.,

A Trade School where Watchmaking is taught practically. We do not manufacture

☼ BICYCLES OR DYNAMOS ☼

at this institute. We confine our work strictly to WATCH WORK and its kindred branches, which include

≡ Engraving, Jewelry Work and Optics ≡

One tuition pays for all the branches. We do not have boy instructors at this institute, all men of years of experience. Each department has its separate instructor. Our institute is open for inspection. We kindly invite you to visit us and inspect our school modes of giving instruction and the progress that our students make by giving them practical instruction.

**THOMAS PENDERGAST,**  
PROPRIETOR AND MANAGER.

**Have you tried it?**

The DALE CHUCK for staffing;  
do so, it will surprise you.

**ALL KINDS \$1.00.**

MADE ONLY BY



**HARDINGE BROS.,**  
1036 LINCOLN AVE., CHICAGO.

**R. M. JOHNSON,**  
IMPORTER OF

**Diamonds and Manufacturing Jeweler,**

67 WASHINGTON STREET,  
ROOMS 5 & 6,

CHICAGO.

MASONIC EMBLEMS OF EVERY DESCRIPTION MADE TO ORDER.



**Detroit.**

M. S. Smith, 2d, left for California on business last week.

Albert Schaub is in New York purchasing his Spring stock of goods.

J. A. Pratt, of Foster & Bailey, visited the jobbing trade here last week.

H. D. Brown, Kingsville, Ont., spent a few days here last week. He is now in Chatham, Ont.

Joseph B. Tasker, with the Canada Smelting & Refining Works, was here last week. The firm recently organized in London, Ont.

Only a few Michigan country jewelers put in an appearance last week. Among them were Frank Nolan, Hadley; and J. C. Bates, New Haven.

Lewis Mueller, manager of F. G. Smith, Sons & Co.'s manufacturing department, is in Florida for the benefit of his health. His family is with him.

The building corner of Grand River and Woodward Aves., occupied by Hollister & Co., jewelers, will be torn down about May 1. The firm have not yet decided where they will locate.

The following jewelers have contributed handsome prizes to the winners in the dog show, now being given by the City of the Straits Kennel Club: Wright, Kay & Co.; F. G. Smith, Sons & Co.; William Genicke,

and Kennedy & Koester, Detroit, and Bradley Bros., Windsor, Ont.

**Indianapolis.**

John M. Sims, of Heaton, Sims & Co., has left for California in search of health.

C. E. Walker, Redkey, Ind., has moved into a new room. Mr. Walker's store was recently burned out.

Fred H. Schmidt & Co. have been taking advantage of dull trade to repaper their store and put in new show cases.

J. Chancy, buyer for the jewelry department of the Pettis Dry Goods Co., has returned from a purchasing trip to New York.

C. E. Barnes, Princeton, Ind., and Geo. A. Fletcher, Carthage, Ind., were seen last week among the wholesale houses.

During the absence of Messrs. Heaton and Sims who will spend several months in California, John Gardner, one of their travelers, will act as manager of the business. He has just finished a trip for the house.

The Valparaiso Mfg. Co., of Valparaiso, Ind., have incorporated with a capital stock of \$10,000, to manufacture clocks, watches, electrical instruments and machinery. The directors are John W. Elam, T. S. Wenk, Grant Crumpacker, C. B. Woodard and James W. DuLaney.

**Lancaster, Pa.**

Ernest Zahm, the well-known manufacturing jeweler, is in a serious condition from pneumonia. He has been confined to his bed for a week.

Among the traveling men in town the past week were: C. B. Pray, Shafer & Douglas; Fred L. Baker, Hayden W. Wheeler & Co.; Geo. M. Kite, Quaker City

Watch Co.; H. Allyn Parker, Bassett Jewelry Co.; N. Coughlin, for Wm. Link; Jas. McPhail, Ed. Todd & Co.; J. F. Dean, Reed & Barton; L. A. Burt, R. Wallace & Sons Mfg. Co.

**Burglars Active in Montreal.**

MONTREAL, Can., March 8.—At 2.30 o'clock Saturday morning an alarm was sent in to the John A. Grose Electric Protection Co. indicating that something was amiss at Alfred Eaves' store, 1679 Notre Dame St. Several men at once went to the place and saw two short thickset men running away. The wire screen outside the window had been broken down and the plate glass window had been smashed, evidently with a hammer. Fortunately the arrival of the watchman had prevented their stealing anything.

This makes a dozen windows of jewelry stores that have been smashed within the last month, and the Burglary Guarantee Co. offer a reward of \$100 to any detective, police officer or private citizen who will secure the conviction of these men, for they are confident that the same persons are responsible for them all.

An attempt was also made to burglarize the premises of W. Beatty, jeweler, 137 Bleury St., but the burglar alarm was this time too quick for the robbers. They broke a 10x12 pane of glass in the back door and the alarm sounded in the office of the Burglar Guarantee Co. Two of the staff at once ran to the scene. A search was made in the yard in the rear when the broken pane was discovered and a thorough investigation made of the surroundings with the result that two men were found concealed, hiding in a corner. They gave the names

**Engravers' Type.**

A Rubber Type in new styles specially adapted to Engravers' use. Seven different sizes now ready.

*Minnie S. Foster*  
*Sir Walter Scott.*

Does away with all tracing. Letters are stamped upon the article in clear cut script or old English. The outline can readily be engraved by even the apprentice. Type made on new principle, beveled edge; alignment guaranteed. Every Engraver should have it. Write for particulars.

WM. H. DIETZ,  
117 Dearborn Street, Chicago.



**GIBSON HOUSE,**

CINCINNATI, OHIO.  
ABSOLUTELY FIRST-CLASS AMERICAN PLAN HOTEL.  
\$3.00 PER DAY.

Extra Charge for Parlors and Rooms with Bath attached. The unequalled advantages in central location, liberal management, modern appointments, experienced service and perfect cuisine, have permanently established the Gibson House as The Most Popular First-Class Hotel in Cincinnati.

AMPLE VAULTS FOR THE PROTECTION OF VALUABLES.

**THE GIBSON HOUSE CO.,**

H. B. DUNBAR President and Manager

**DUEBER-HAMPDEN WATCHES.**

The most reliable watches are the Hampden 17 Jewel. A full line of Dueber Cases and Hampden Movements. Cash buyers write us.

**BRETHAUER WATCH & JEWELRY COMPANY,**

SPECIAL AGENTS,

71 WASHINGTON ST., CHICAGO, ILLS.

**THE PLANCHAMP & BECKER CO.**

Makers and Repairers of

**WATCH CASES,**

Gold and Silver Plating —

— of Watch Cases a Specialty.

UNEXCELLED FACILITIES.

63 and 65 East Washington St., Chicago.



**WHEN IN CHICAGO, VISIT THE**  
**Chicago Watchmakers' Institute,**

SUITE, 1521-1523 B MASONIC TEMPLE.

A Modern Trade School for the Watchmaker, Jeweler and Engraver.

Write for New Catalogue.



of William Childs, 28 years of age, and Frederick Davis, 29 years of age. They pleaded guilty, and both were remanded for sentence.

**Cincinnati.**

Jonas, Dorst & Co. received numerous orders for diamond mountings last week.

L. J. Hyde, Rockport, Ind., and Herman Smith, Parkersburgh, W. Va., were in Cincinnati last week.

N. J. Thelan, son of the well-known 5th St. jeweler, has joined the traveling force of Oskamp, Nolting & Co.

Harry R. Brown is now representing the John Holland Gold Pen Co., in the extreme west, going as far as the coast.

E. E. Higgins started on his maiden trip on the road for O. E. Bell & Co. last week. Harry Kemper has returned to this firm and will represent them among the city trade.

Robert M. Shearer, president of the Cincinnati Pure Aluminum Co., has returned from Michigan where he took a large contract for street signs and house numbers.

Duhme & Co. have cut down their force, by eight salesmen. They have now a superfluity of employes, and could spare as many more. Cliff Miller, their popular traveler, was in the suspended list. A. J. Augustine continues to represent them on the road. There was also a cut of 10 per cent. in salaries, including that of the president of the firm.

**Cleveland.**

As an outcome of the opposition which developed in Akron against the sale of their replevied wares at that place, the man in charge of L. H. Goldsoll and Bro.'s interests there has announced that he will endeavor to sell the stock in bulk.

Dulness in business caused Cramton Bros., jewelers, Warren, O., to make an assign-

ment of all their stock of watches to E. O. Dilley, Tuesday last, for the benefit of their creditors. It is believed that the assets of the firm are nearly sufficient to offset the liabilities.

A constable from Justice McKay's Court served a writ of replevin, Friday, on L. H. Goldsoll & Bro., jewelers, in the Beckman block, at the instance of A. C. Smith, New York, the merchandise consisting of watches, watch cases and watch movements. Chas. Ettinger was made defendant.

**Kansas City.**

Amos Plank, the veteran jeweler of Hutchinson, Kan., was in Kansas City a few days ago, buying goods.

G. V. Dickinson, representing the Elgin National Watch Co., was in Kansas City a few days ago looking after the trade.

S. Harvey Horner, a jeweler of Caldwell, Kan., is a candidate for the Republican nomination for Congressman of his district.

Steve Smith, a veteran traveling man from Providence, R. I., is now representing the Edwards & Sloane Jewelry Co., of Kansas City, in the west.

Flint Bowen wants some jewelers' agent to take part of his office in the Keith & Perry building and look after his business while he is on the road. He has moved his office to the fourth floor of the building and has added a line of sterling silver novelties.

A. E. Self, who for the past year has been connected with the engraving department of the Edwards & Sloane Jewelry Co., will leave March 20 for England, his mother country.

Mr. Hoefler, of Woodstock, Barger & Hoefler, is making a trip through Nebraska. He attended the meeting of the Nebraska Retail Jewelers' Association at Lincoln, March 14 and 15.

Flint Bowen, western agent for the Wm.

L. Gilbert Clock Co. and the Wendell Mfg. Co., left last week for a trip through Colorado and the west. He will be away from Kansas City about 10 weeks.

Jeweler Herman Streicher has brought suit for \$255 against Ed. Findlay, a well-known gambler and "boss" politician. He alleges that he sold goods to J. E. Ackerman on Findlay's guarantee, for Ackerman to sell again to gamblers.

The following out-of-town jewelers were in Kansas City last week buying goods: J. H. Whiteside, Liberty, Mo.; B. R. Smithers, Cameron, Mo.; J. S. Burson, Belton, Mo.; W. H. Meyer, Lawson, Mo.; B. Hoffmann, Leavenworth, Kan., and F. S. Hester, Laurence, Kan.

A telegram received by one of the wholesale houses here says that burglars broke into Shane's jewelry and drug store, McCune, Kan., a few nights ago, blew open the safe and stole about \$1,100 worth of jewelry. Among the things stolen were 58 watches and one watch worth \$175, which had been left for repairs.

A judgment for \$47,000 has been entered in the District Court at Emporia, Kan., against E. A. Hosier and Geo. B. Hosier, with Cady & Olmstead, jewelers, Kansas City, who shipped a lot of cattle to Kansas and brought Texas fever into the State. They were sued by 159 farmers whose cattle became infected. A history of the unfortunate venture of the two jewelers was told in a recent issue of THE CIRCULAR.

Workmen are engaged in making extensive improvements to G. A. Schlechter's jewelry store, Reading, Pa. Heretofore the Penn St. front included two store rooms. The partition will now be taken away, making one room. A continuous show window will be put in from the entrance at 6th St., along Penn St. 37 feet. The store will be fitted up with the latest and handsomely designed show cases and counters.

**The Wadsworth Watch Case Co.**



General Offices,  
**NEWPORT, KY.**

Filled



Cases.



Chicago Office,  
**COLUMBUS BUILDING,**



**DIAMONDS.****Wm. S. Hedges & Co.,**

Importers of Diamonds,

And Manufacturers of DIAMOND JEWELRY.

170 Broadway, New York.

22 Holborn Viaduct, London.

**Notes from Fashion's Center.**

THE CORBEILLE AT THE MARRIAGE OF THE DUKE D'UZES—A CURIOUS FASHION IN PINS—UNIQUE STYLES IN BROOCHES, SHOULDER PIECES AND OTHER JEWELRY—THE PROMINENCE OF THE EMPIRE STYLE—M. MOISSAN DISCUSSES HIS DISCOVERIES IN THE PRODUCTION OF DIAMOND.

PARIS, France, March 3.—At the marriage of the Duke d'Uzes with Mdlle. Marie-Thérèse de Luynes which took place recently, the *corbeille* contained a great number of costly presents from the *fine fleur* of the French aristocracy. Two magnificent diamond rivières, a diamond tiara, a necklace consisting of large rubies and diamonds alternating, a very supple and artistic diamond lace bow-knot, a bracelet formed of rubies and diamonds, also one having on the clasp two large white and black egg shaped pearls, one adorned with a half conical *cabochon* emerald circled with brilliants, another with a very large sapphire surrounded with diamonds, a fan with an elegant *motif* formed of rubies, emeralds and diamonds starting from the monogram, and coursing gracefully up the handle, etc.

A curious fashion in scarf and hat pins consists in having as the pin head a large pearl, either pink, gray, white or black, with a tiny diamond snake curled slantingly around it; the lilliputian serpent may be replaced by a fly resting on a minuscule sprig of flowers; a turquoise may be used instead of a pearl.

Bands of gold lace, or close net-work, embroidered with floral or conventional *motifs* made of precious stones, are worn in the way of borders on handsome receiving gowns.

A pretty brooch is a wind-flower of diamonds with lines of tiny rubies; the flower is drawn and curled into the shape of a cornucopia. A light and graceful diadem shows in front a dragon fly in vari-colored stones, resting on a reed gracefully bent and surrounded by other reeds arranged so as to give an effect at once natural and symmetrical.

A curious shoulder piece is a shallow diamond shell with several rows of brilliants diminishing in size, and arranged to imitate water falling out of a shell.

The success of Sardou's last play, *Madame Sans-Gêne*, has strengthened the vogue of the Empire style. I noticed at the opera a pretty costume in this style worn by a young married woman. The front of the corsage was covered with gold tulle, embroidered with precious stones and black pearls. On each shoulder was a puffing velvet ribbon of a sunny color, adorned with a classical *motif* formed of emeralds and diamonds. Straw colored feathers bordering the top of the low necked bodice were sprinkled with brilliants. On the head was a turban of amber colored tulle, showing in front a cluster of feathers shooting up gracefully, with a large emerald at the base and a few

**R. A. KIPLING,**

Importer of

**PRECIOUS STONES,**

21 &amp; 23 Maiden Lane,

19, RUE DROUOT,  
PARIS.

New York.

**CALIFORNIA  
MIDWINTER FAIR.****Novelties** 

IN

Sterling and Plated  
Souvenir Spoons, Silver  
Plated Trays, Match Boxes,  
Paperweights, Charms, Sleeve  
Buttons, Rings, etc., etc.**Julius Eichenberg,**174 Weybosset Street,  
Providence, R. I.

DON'T FORGET THE JEWELERS' CIRCULAR PUBLISHING CO.'S BOOK LIST when in want of any technical book in the Jewelry or Kindred Trades.

**Alfred H. Smith & Co.,****IMPORTERS****DIAMONDS**

AND

**PRECIOUS STONES,**

182 BROADWAY, COR. JOHN STREET,

NEW YORK.

88 Holborn Viaduct, London, E. C.

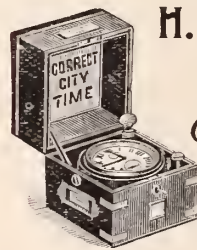
**H. H. HEINRICH,**

14 John St., N. Y.

MARINE

**Chronometers**

for Rent and Sale.

Large Stock on Hand.

Springing, Readjusting and  
Repairing for the trade.

Easy Terms. Send for Price List.

**OPPENHEIMER BROS. & VEITH,**

WATCHES AND

**DUEBER CASES, HAMPDEN MOVEMENTS.**

AMSTERDAM, HOLLAND, 2 TULPSTRAAT.

LONDON, ENG., 28 HOLBORN VIADUCT.

NEW YORK, 35 MAIDEN LANE.



diamonds glittering here and there in the feathers.

Among the numerous costumes worn in *Cabotins*, Pailleron's new play, at the Theatre Francais, one of the most striking is that of Mdle. Thomsen, being of buttercup colored satin covered with a Greek tunic embroidered with topazes and turquoises; the sleeves are prettily adorned with the same gems.

At the sitting of the Académie des Sciences, held on the 12th ult., Mr. Moissan exposed the results of his recent experiments in order to produce diamonds. He stated that instead of plunging into water the red hot iron ingot containing carbon, he put it into a melted lead bath at a temperature of 400° centigrade, and thus managed to obtain diamonds half a millimeter thick, the having all properties of genuine diamond.

The biggest diamonds which Mr. Moissan obtained with his experiments, weighed only 6 milligrammes. The idea has since struck him that the extreme smallness of the crystals might be due to the way the iron ingot had cooled, on the ground that when an ingot, heated at a temperature of 2,000° centigrade, is plunged into cold water, it happens that the liquid, through an effect of calcification, does not come into contact with it; it is therefore by radiation through the surrounding steam that the ingot gradually cools.

Mr. Moissan endeavored to find another way to obtain sudden solidification by reducing the difference of temperature. He used first a bath of melted tin, but that did not answer the purpose, as it produced at a rather high temperature, an alloy of tin and iron. With a bath of melted lead, maintained at a temperature of 400°, the result proved to be entirely different. Tiny iron globules ascended to the surface of the lead bath by reason of their inferior density. These globules being collected with a skimmer, and the iron dissolved with acids, diamonds half a millimeter in diameter were obtained. Some, triangular in shape, exhibited a striated surface, others somewhat round, were covered with tiny *cupules*.

Mr. Moissan remarks that such is the appearance of some genuine diamonds. Some triangular diamonds became segmented after a while; this phenomenon often occurs with genuine stones, after being unearthed. By sinking them into a heap of iron filings and allowing them to cool there, Mr. Moissan caused his productions to show all the characters of diamonds which *joailliers* call *crapauds* (toads). These stones are easily burnt in oxygen at a temperature of 900°; triangular diamonds may be burnt, but they leave a residue of sparkling grains probably consisting of *silicure* of carbon.

JASEUR.

L. G. Burnham, Burlington, Vt., intends to close out his entire stock.

ESTABLISHED 50 YEARS.

# RANDEL, BAREMORE & BILLINGS,

IMPORTERS OF

## DIAMONDS,

AND OTHER PRECIOUS STONES.

FINE PEARLS A SPECIALTY.

MANUFACTURERS OF

## DIAMOND JEWELRY,

IN THE LATEST DESIGNS.

Diamonds Recut in Modern Styles or Repaired on Premises.

58 Nassau Street,  
29 Maiden Lane  
NEW YORK.

1 Tulp Straat,  
AMSTERDAM.

1 St. Andrews St.,  
Holborn Circus,  
LONDON, E. C.



TRADE MARK.

ESTABLISHED 1841.

# CARTER, SLOAN & CO.,

## MANUFACTURERS OF GOLD JEWELRY,

No. 15 MAIDEN LANE,

NEW YORK.

A. CARTER, JR.  
A. K. SLOAN.  
C. E. HASTINGS.

GEO. R. HOWE  
WM. T. CARTER.  
WM. T. GOUGH.

FACTORY, NEWARK, N. J.



# JOHN N. DISSELKOEN,

Gutter and Importer of

## DIAMONDS

FACTORY,  
76 LANGELEKERSPAD.  
AMSTERDAM.

19 East 16th St.,  
NEW YORK.





### The Trade's Forum.

GORHAM MFG. CO'S. WORLD'S FAIR AWARDS.

NEW YORK, March 8, 1894.

Editor of THE JEWELERS' CIRCULAR:

We notice in the last number of THE CIRCULAR an article signed "Veritas," which refers to our advertisement published in the Silver Anniversary Number. Regarding the comment made upon the claim by us in that advertisement, we desire to say that we especially referred to the number of awards as being the largest number given to any *single*

*exhibit* at the World's Fair. This seems to us perfectly clear as referring only to the single exhibit in the Manufactures and Liberal Arts building, and therefore our statement needs no correction. We were aware at the time the advertisement was written that Messrs. Tiffany & Co. were not only splendidly represented in the same department of the exhibition as ourselves, but that they also had important exhibits in other buildings and in many other lines of goods that were quite outside of lines represented by us.

One statement made by your corre-

spondent seems to call for a reply from us as it would mislead, or it would seem to mislead one unacquainted with the method pursued by this company, by conveying the impression that the Gorham Company had exhibited goods not of their own manufacture or design, and therefore we will state here that not a single piece of any product was exhibited by us for competition that was not designed by our own staff, and the only articles exhibited by us not our own manufacture was the glassware which was wholly our design and manufactured to those designs by Messrs. John Hoare & Co., of Corning, New York, but mounted by us.

We append with your permission the list of awards granted to the Gorham Company and we repeat the assertion that it is the largest number of awards given to any single exhibit at the World's Fair.

GORHAM MFG. CO.

- No. 1. Artistic display as a whole.
2. Sterling Silver Ware.
3. Fine Art Pieces.
4. Special Silver and Glass Dessert Service.
5. Silver Dinner Service, Repoussé Chased.
- 6, 7, 8. Silver Hollow Ware, 3 awards.
9. Special Exhibit of Prize Pieces.
10. Special Exhibit of Silver Gilt Ware.
- 11, 12. Enameling on Silver, 2 awards.
- 13, 14. Painting on Enamel, 2 awards.
15. Translucent Enamel.
16. Champlevé Enamel.
17. Cloisonné Enamel.
18. Blown in Glass.
19. Silver Mounted Cut Glass and Crystal.
20. Silver Deposit on Glass and Pottery.
21. Ecclesiastical Goods.
- 22, 23. Ecclesiastical Silver and Gold, 2 awards.
24. Ecclesiastical Electro-Plate.
25. Ecclesiastical Brass.
26. Statuary in Silver, Bronze and Brass.
27. Bronze Statuary.
28. Bronze Castings.
29. Knives, Forks, Spoons, etc.
30. Silver Flat Ware.
31. Toilet Ware.
- 32, 33. Electro-Plated Ware, 2 awards.
34. Medal Work, in Gold, Silver and Bronze.
35. Hard Wood Chests.
- 36, 37. Gold and Silver Mounted Leather Goods, 2 awards.
38. Carved Leather.
39. Silver Mounted Card Cases and Purses.
40. Silver Mounted Pocket Books.
41. Silver Mounted Traveling Bags.
42. Silver Mounted Hand Bags.
43. Silver Mounted Portfolios.
44. Silver Mounted Cigar Cases.
45. Silver Mounted Leather Cases.
46. Silver Mounted Umbrellas.
47. Silver Mounted Canes.

Reuben W. W. Wheeler and Walter K. Shearman will open a jewelry store at 42 Main St., Penn Yan, N. Y., about April 1st. About a year ago Mr. Wheeler left the employ of E. H. Hopkins, to engage in business in Ithaca, N. Y., and went back to Penn Yan a week or two ago, and secured the store at the above number.

# CHARMILLES

(PRONOUNCED SHAR-MEAL.)

is the name of a new **HIGH GRADE, LOW PRICE WATCH** constructed on an entirely new and novel plan and which is now being put on the market through the jobbing trade, and will be extensively advertised to the trade and general public.

**IT IS SURE TO BE A WINNER,**

as it possesses greater merit than any watch made for the money.

**. . . ASK YOUR JOBBER FOR THEM . . .**

# VALLENTINE'S Plating and Repairing Works.

258 GRAND ST., NEW YORK.

### IMPORTANT NOTICE.

Owing to false representations as to the location of our factory, we beg to call the attention of the trade to the fact that we are located as above. We have the finest plant and factory in the city, and are fully equipped for turning out work in the following branches:

**GOLD PLATING.  
SILVER PLATING.  
NICKEL PLATING.  
BRONZING.**

**POLISHING.  
CASE REPAIRING.  
JEWELRY REPAIRING.  
ENGRAVING.**

**OXYDIZING.**

We do all this work in our own factory and do not have to send anything to outsiders to be done, thus saving additional cost.

**SPECIAL ATTENTION GIVEN TO OUT OF TOWN ORDERS.**

**ROY**

The Roy Watch Case Co. Cases  
assay among the highest.

**ROY**



**Boston.**

Herbert W. Richards is in California on a business trip.

Treasurer Arthur M. Little, of the E. Howard Watch & Clock Co. is in New York.

Charles T. Derry, salesman for Smith & Patterson, says 'tis a girl and is receiving congratulations.

F. E. Treibs, of Oberstein, Germany, representing Treibs Bros., was among the visitors to the Boston trade last week

The E. Howard Watch & Clock Co. are putting up five striking clocks with three 8-foot dials on the town hall at Apponaug, R. I.

Thomas Pray, who has been under the weather for upwards of three weeks, was able to return to business a few days ago.

Joseph C. Batchelder, of Smith & Patterson's silverware department, has gone to New York on a business trip for the house.

Harry H. Vaughn, who was operated upon last Summer when he had an attack of appendicitis, is suffering from inflammation and may be obliged to undergo further surgical treatment.

The time for the annual ladies' night banquet of the Boston Jewelers' Club has been decided upon, and the event will take place at the Parker House March 27, the dinner to be followed by a short entertainment in the suite engaged for the occasion.

In a circular addressed to the jewelry trade and sent out from the office of George H. Richards, Jr. & Co., last week, notice was given that the stock and business of the late George H. Richards, Jr., have been purchased by Herbert W. Richards, son of the late proprietor, and the establishment will be continued by him under the old firm name and style of George H. Richards, Jr. & Co., by consent of the legal representatives.

**Philadelphia.**

Simon Muhr has returned from a trip to Florida.

J. Tweedal has opened a new store in Frankford Ave.

C. H. Hurlburt and S. Stern made business trips to New York last week.

Henry Newberger has abandoned his business experiment and is back again with H. Muhr's Sons.

An unsuccessful attempt at robbery was made at H. Ogden's Sons', Germantown Road store one night last week.

Charles H. Higbee, representing the Jewelers' League and Jewelers' Security Alliance, spent several days in Philadelphia last week.

George Kite, formerly with M. J. Sheridan, has joined the Quaker City Watch Co., and is performing the duties previously attended to by the late Secretary Watson.

Adolph Naundorf, 120 S. 7th St., wishes to secure three or four apprentice boys of good character, who wish to become proficient in fine watch and clock repairing.

The Retail Jewelers' Association having abolished the commissionership. L. P. White has become local wholesale agent for the Illinois Watch Co., the Philadelphia Watch Case Co., and the Waterbury Clock Co.

Wm. Faber & Sons, 738 Sansom St., manufacturers of sterling silverware, have made a new departure in the matter of catchy small novelties. They have also added to their plant the facilities for the extensive manufacture of hollow ware.

Henry Streutz, dealer in watch materials and tools, has moved the stock from his store at 702 Chestnut St., to the establishment recently purchased by him at 719 Sansom St. The consolidation of the two stores and the excellent location on the ground floor, will greatly increase his facilities.

Last week a man visited a number of houses in the northwestern part of the city and represented himself as a jeweler at 4112 Market St. He said his name was William Mercer. From several people he obtained watches and clocks to repair, and that was the last heard of him. There is no jewelry store at the address named.

A. Reed McIntire, Harry C. Ulmer and Edgar A. Brown, employees of the Philadelphia Optical & Watch Co., together with Geo. W. Magee, an expert optician, have formed a copartnership for the purpose of transacting a general jobbing, repairing and manufacturing optical business. Their factory, at 127 S. 8th St., is well equipped. They have skill, energy and personal popularity on their side and should succeed.

On Thursday last Jacob Vetter, a Manayunk jeweler, was held in \$500 bail for court by Magistrate Roney, on the charge of larceny as bailee. The charge was preferred by Patrick Costello, who said that he gave Vetter his watch to repair, and that when he called for it Vetter told him it had been lost or stolen. He, however, offered to replace the loss by another watch, which Costello would not accept because it was much less valuable than his own.

In Court of Common Pleas, No 3, Saturday, Judge Finletter issued a special injunction in equity proceedings brought by the Gorham Mfg. Co. against B. A. Carruthers, 627 S. 10th St. The bill alleges

that Carruthers obtained a large quantity of silverware to be replated, as the customers supposed, by the Gorham Mfg. Co., but which were either replated by him in his own residence or at some other silver plating establishment in this city. The Court is asked to issue an injunction restraining the defendant from representing himself as the agent of the company and from soliciting silver plating or silver in the Gorham Mfg. Co.'s name; and also such further relief as the Court may designate.

**Canada and the Provinces.**

Wm. Wadds has opened a jewelry store in Vancouver, B. C.

The store of J. A. Mills, jeweler, Fort William, Ont., was burned out last week.

A meeting of the creditors of Chas. A. Addison, Ottawa, Ont., was held recently, but owing to the absence of the creditors nothing definite was done. The stock which is to be sold, amounts to about \$3,000 and the liabilities to about \$7,000.

The Dueber Watch Case Mfg. Co., Canton, O., are suing E. N. Williams, Toronto, for \$5,000, which they claim was sent to him by them several months ago to pay off chattel mortgages against the company here. The suit will be tried this week, when the company's treasurer, Col. Moore, will be examined.

W. F. Doll, Winnipeg, Man., is in Montreal circulating a petition among jewelers and watchmakers, asking the Government to pass legislation compelling manufacturers of watch cases to stamp in them the quality of the goods, and also asking for a reduction in duty on clock and watch cases from 35 per cent. to 10 per cent.

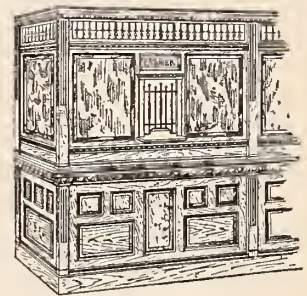

**WM. SCHWARZWAELDER & CO.,**

Fulton St., cor. Pearl, - NEW YORK.

MANUFACTURERS OF

Jewelers' Cases and Counters, Office Partitions, Rails, Desks, Chairs, Etc.

Special Designs, Plans, Prices, etc. upon application.



The Roy Watch Case Co. Cases are Sold only through Jobbers.







## Our Traveling Representatives

Traveling representatives may consider these columns open for the publication of any news or items of interest regarding themselves or their confreres.

**T**RAVELING men calling upon Davenport, Ia., firms the past week were: Irving Alsborg, Max Freund & Co.; G. T. Seal, Maltby, Henly & Co.; I. S. Richter, Bruhl Bros. & Co.; Louis Hirsch,

Lissauer & Co.; Mr. Steele, J. B. Bowden & Co.; Josh Mayer, Powers & Mayer; S. W. Abbey, E. Ira Richards & Co.; A. G. Stein, L. H. Keller & Co.; Max Noel, Stein & Ellbogen Co.; E. B. Frank, Pairpoint Mfg. Co.; O. Derndinger, C. H. Knights & Co.; Jos. Bloch, Swartzchild & Co.; H. E. King, Holmes & Edwards Silver Co.; W. C. Bliedung, J. H. Purdy & Co.; Carl P. Hoffman J. J. Sommers & Co.; J. K. Carlisle, Detroit Umbrella Co.

The traveling fraternity was represented in Philadelphia the past week by: E. Block, W. & S. Blackinton; F. Hoyt, Hoyt & Weller; Ed. Eckfeldt, Wm. B. Kerr & Co.; Ed. Ackley, Unger Bros.; H. Granbery, W. G. Clark & Co.; H. Levy, Herman Levy; Harry Ingram, Alling & Co.; S. E. Hyman, Lewisohn & Co.; Cheever Hudson, H. F. Barrows & Co.; and Fred Lewis, Lewis, Kaiser & Luthy.

The eastern factories were represented in Chicago last week by Wm. H. Morris, J. W. Richardson & Co.; Wm. A. Wightman, R. F. Simmons & Co.; Mr. Metcalf, R. Blackinton & Co.; Mr. Whiting, Wade, Davis & Co.; Mr. Carrow, J. J. Sommers; G. C. Booth, Hutchison & Huestis; M. L. Jacoby, Providence Stock Co.; Harry B. Kennion, H. D. Merritt & Co.; E. I. Rogers, Parks Bros. & Rogers; M. J. Straus, Hammel, Riglander & Co.

Traveling men in Pittsburgh last week were: E. T. Hopkins, Meriden Silver Plate Co.; Luther Hyde, Reed & Barton; Cheever Hudson, H. F. Barrows & Co.; Samuel Baldwin, Baldwin, Ford & Co.; Samuel Howland, Eisenmann Bros.; Lou Fay, Kirby, Mowry & Co.; Al. L. Henderson, Prentiss Clock & Calender Co.; Mr. Bingham, Dueber Watch Case Co.; Robert Welch, Welch & Miller; Lawrence H. Smith, Bippart & Co.; A. E. LaVigne, Mathey Bros., Mathez & Co.; H. A. Bliss, Eremetz & Co.; C. W. Cary, J. B. & S. M. Knowles Co.; M. L. Jacoby, Providence Stock Co.,

and M. E. VanBerg, Van Berg Silver Plate Co.

Indianapolis was last week visited by the following representatives: G. D. Munson, Wm. Rogers Mfg. Co.; W. Bixby, Frank W. Smith; Mr. Boice, Lewison, Boice & Smith; T. V. Cannon, W. J. Braitsch & Co.; W. A. Strauss, Jacob Strauss & Sons; Mr. Melcher, Bennett, Melcher & Co.; C. O. E. Hartung, Sussfeld, Lorsch & Co.; M. L. Jacoby, Providence Stock Co.; L. O. Cowell, Cowell & Hall Mfg. Co.; C. F. Willem, H. Muhr's Sons; S. Levy, S. Levy & Co.; I. L. Lake, American Waltham Watch Co.; Zach Fuller, Fuller & Mayer; Geo. Pearse, Short, Nerney & Co.; W. H. Steere, Arnold & Steere; E. I. Rogers, Parks Bros. & Rogers; E. A. Tyler, Ansonia Clock Co.; and a representative of Henry Schade.

Traveling men in Boston last week included: M. Baum, Rothschild Bros.; Chas. Bennett, Jacob Bennett & Son; John L. Shepherd, Keystone Watch Case Co.; Frank Sherry, Jos. Fahys & Co.; George A. Griffin, Julius King Optical Co.; R. H. Baxter, A. A. Weeks; H. E. Bleecker, Bassett Jewelry Co.; Mr. Miller, Seth Thomas Clock Co.; E. Horton, J. B. Bowden & Co.; E. A. Bliss, Bliss Bros.; Thos. F. Fessenden, T. F. Fessenden & Co.; Mr. Williams, Holmes & Edwards Silver Co.; H. W. Dunham, Meriden Silver Plate Co.; C. H. Barney, Middletown Plate Co.; H. B. Beach, Wilcox Silver Plate Co.; J. D. Pettengill, Derby Silver Co.; E. W. Martin, Martin, Copeland & Co.; Henry G. Thresher, Waite, Thresher Co.; A. Simons, Stern Bros.; W. H. Tarlton, Wightman & Hough Co.; Louis Combremont; John A. Abel, Lewis, Kaiser & Luthy; John Taylor, Kremetz & Co.; Frank Wood, Carter, Sloan & Co.; James A. Cheney, Ludwig Nissen & Co.; Charles S. Isabel, Louis Strasburger's Son & Co.; Mr. Alexander, Whiting Mfg. Co.; Henry E. Ide, H. C. Hardy & Co.

Traveling salesmen were unusually numerous in Syracuse, N. Y., the past week. Those noticed were: D. Cohn, Stone Bros.; E. H. Koehn, Alfred Koehn; E. L. Coggeshall, Rogers, Smith & Co.; R. W. Simpson, Jr., Riker Bros.; Louis Lassner, Goodfriend, Bros. & Lassner; C. E. Thomas, Manhattan Silver Plate Co.; A. Lape, Simpson, Hall, Miller & Co.; J. Engel, Lissauer & Co.; Geo. B. Kenrick, Reed & Barton; C. A. Vanderbilt, Coddling Bros. & Heilborn; M. Baum, Rothschild Bros.; Clarence E. Johnson, L. H. Keller & Co.; W. F. Martins, J. S. O'Connor; Alva J. Lasher, Whiting Mfg. Co.; Mr. Whiting, S. E. Fisher & Co.; W. B. Osgood, Hamilton Watch Co.; Geo. R. Cowell, Cowell & Hall Mfg. Co.; Wm. A. Wightman, R. F. Simmons & Co.; Henry Lederer, S. & B. Lederer; R. G. Schutz,

E. L. Logee & Co.; G. P. Granbery, J. L. Granbery; Hugo Citroen, Vve. L. B. Citroen & Co.; A. S. Sulzberger, Sulzberger & Gunzburger; F. W. Francke, Bell Bros. Co.; T. Guntzburger, Stern & Frank; Theodore Parker, Martin, Copeland & Co.; W. H. Browne, Wilcox Silver Plate Co.; Mr. Waterman, Waterman & Lehmann; Geo. L. Paine, E. I. Franklin & Co.; Mr. Posner, Wallach & Schiele.

### Pittsburgh.

G. A. Spandan has returned from a business trip to New York.

R. Siedle & Sons are indulging in a Spring house-cleaning, painting, etc.

J. Alex. Hardy, of Hardy & Hayes, has gone east to purchase Easter novelties.

Heeren Bros. & Co. have been very busy moving to their handsome new stores on Penn Ave.

Mr. Chessman, of the Chessman Optical Co., will open a department store in Solomon & Reuben's stores, on Smithfield St.

B. E. Arons has entered suit against the M. & M. Bank for \$5,000 damages for the protest of a note. The case will be heard this week.

C. S. Hauser, formerly of Smithfield St., has returned to his old stamping ground, viz.: the East End, and has located on Frankstown Ave.

J. C. Grogan has made a noticeable improvement in the exterior of his store on Market St., having the entire building painted a snow white.

John Roberts has removed, earlier than anticipated, to 431 Market St., and his windows are already handsomely decorated. Grogan, Roberts and Reed occupy adjoining stores.

Jack Allison and Chas. O'Brien, travelers for Goddard, Hill & Co., have returned from trips; the former had spent a week at Monongahela City. Ed. Straw, of the same firm, is still in the west.

John Kennedy, formerly with Heeren Bros. & Co., has now taken entire charge of R. Biby's store in Wilksburg, Pa. Dr. Biby, being a successful practicing physician, has decided to devote more time to his profession.

Among out-of-town buyers registered here during the past week were: A. Brauchler, Greensburg; E. H. Kennerdell, Tarentum; D. F. Rosen, West Newton; A. E. Siviter, Wilksburg; Max Rudert, Duquesne; J. Linnenbrink, Rochester; A. Winter, Zelienople; L. Schmidt, Braddock; R. Biby, Wilksburg; J. W. Miller, Butler, and A. Merz, Sewickley.

The best Trade use the **ROY** Watch Case Co. Cases.



## News Gleanings.

A. J. Sugar, Bel Air, Md., is going out of business.

S. B. Strunck will open a jewelry store in Bath, Pa.

H. G. Hudson, Merrimac, Mass., is settled in his new store.

Alex. J. Gouley has opened a new jewelry store in Morristown, N. J.

Dr. Vineburg, optician, Albany, N. Y., has removed to 2 N. Pearl St.

H. H. Boss, jeweler, at New London, Wis., has made an assignment.

Louis Selig, Elizabeth City, N. C., has leased another store in that town.

Frank A. Beh has opened a repair shop at 6 Cayuga St., Seneca Falls, N. Y.

H. J. Howe, Syracuse, N. Y., returned on Saturday from a week's stay in New York.

O. L. Rundell has removed from Rushford, Minn., to Spring Valley, same State.

A. Horowitz, jeweler and optician, Hudson, N. Y., will give up business in that town.

The business of Geo. Williams, Adams, N. Y., was affected by a fire in that town last week.

The window of H. Johnston, Portland, Me., was broken last week and two watches were stolen.

R. J. Cushing, Bangor, Me., has been on a business trip to Boston, New York and Philadelphia.

Frank Kaltenbach has sold his store in Black Hills, S. Dak., to S. E. Hesla, of Tama City, Ia.

R. F. Gresham, lately of Cleveland, O., intends opening a jewelry store on Chillicothe St., Portsmouth, O.

Bryant & Veberg is the name of the new firm in Deadwood, S. Dak., to manufacture native gold jewelry.

Mr. Beard, of Sicho & Beard, St. Paul, Minn., started out on his first trip through the northwest last week.

F. J. Maw and Wm. W. Arms will open a jewelry store in Janesville, Minn. The firm name is Maw & Arms.

The business of George E. Sherwood, Waterloo, N. Y., was damaged by fire last week to the extent of \$150.

Charles A. Hamman, Bath, Me., has returned from New York with a diploma from the Spencer Optical Institute.

Charles S. Gallagher, representing Tower & Lyon, New York, called on the Twin Cities jobbers the past week.

E. R. Whitney has removed from Blanchard, Ia., to Westboro, Ia. He will engage in the jewelry business at that place.

S. Harry Lesser, of A. Lesser's Sons, Syracuse, N. Y., returned on Saturday from a three weeks' trip through Pennsylvania.

A. N. Jackson, formerly an employe in the American Waltham Watch factory, will start a new store this week in Union, Me.

The Boston Watch & Clock Co. are conducting a sale of clocks and watches at the wholesale store of Tuck & McAllister, Bangor, Me.

A. E. Saxton, Washington, N. J., will have an auction sale on Thursday, March 15th, preparatory to moving into the Uehlein building.

John T. Schmidt, of the late firm of Schmidt & Keck, Glenwood, Col., has departed with his family for their old home in Tennessee.

Reinhardt Bros., Lincoln, Ill., have been succeeded by Reinhardt & Mittendorf, Louis Mittendorf having bought out the interest of Matt Reinhardt.

The creditors of H. H. Pratt, Fremont, Neb., have agreed to permit the sale of the jewelry stock at a private sale. The invoice is complete and shows a stock of \$4,700.

The storeroom, 653 Penn St., Reading, Pa., is being remodeled and will be occupied in a few weeks by Joe Loeb, diamond broker, at present in the Young building.

Some time late last Saturday night the store of McKee & Wood, Gainesville, Tex., was burglarized and over \$150 worth of jewelry taken, besides other valuable booty.

H. L. Stolz, who has been engaged in the jewelry business in Bellwood, Pa., the past three years, is now closing out his stock and is making preparations to leave town by the 21st.

The store of Bear & Co., Rock Island, Ill., was burglarized Tuesday night last and about \$20 worth of jewelry taken, while about \$13 in cash was secured from the money drawer.

W. M. Farrington, Brewer, Me., who has been located on Centre St., is moving into the Burr block on Main St., where he will occupy one of the windows in J. A. Fairbanks & Co.'s store.

S. Stern, optician, Kingston, N. Y., under whose name an impostor has been selling fake spectacles in that city and vicinity, has located the man in New York, and says he intends to have him arrested.

The Excelsior Sign & Mfg. Co., Chicago, have just shipped to W. R. Williams, who is starting in business in Brighton, Ia., one of Grout's Excelsior New and Improved No. 50 carved iron watch signs.

A fire which visited Demopolis, Ala., destroying a dozen business houses, burned the jewelry store and stock of William H. Welch. His stock was worth \$2,000, which was partially covered by insurance.

E. E. Spalding, of Spalding Bros., Minneapolis, will represent his firm on the road throughout Minnesota, Wisconsin, Iowa, North Dakota and South Dakota, and will start out on his first trip about the 15th inst.

Samuel Schwab was arrested in Canton, O., last week, charged with embezzlement. He was formerly a clerk for Chas. Ettinger, Ontario St., Cleveland, and it is alleged sold jewelry without making any return to his employer.

A horse crashed into the show window of Trenkley & Scherzinger's store, Ft. Wayne, Ind., last Monday afternoon, falling quivering and bleeding upon the goods displayed. The damage to the stock is \$50, while the loss on the glass was about \$100.

C. S. Durfee & Co., Davenport, Ia., having decided to discontinue business, have sold their fixtures and leased their store to M. E. Nabstedt, of the same city, and will give possession July 1. The Durfee house has been in existence 25 years.

While two farmers were hauling straw from a farm seven miles west of Linneus, Mo., they found a lot of jewelry and watches hidden in the stack. There were also some papers and receipts which proved the jewelry to be the property of Jacob Gardner, a jeweler of Linneus, who was robbed of several hundred dollars worth of jewelry two months ago.

The Anderson Jewelry Co., Milwaukee, Wis., who filed notice of dissolution a few days ago, began as retail jewelers at the corner of E. Water and Wisconsin Sts., afterward beginning a manufacturing business on one of the upper floors of the same building. The retail business was later disposed of to the Weber Jewelry Co., who are now conducting an auction sale as the store will be converted to the purposes of a bank the coming month.

## Springfield, Mass.

George E. Patton, North Adams, will move his place of business to another store on Main St.

The following traveling men visited this city within the past week: J. C. Donnell, Ripley-Howland Mfg. Co.; A. S. Sulzberger, Sulzberger & Gunzburger; R. G. Schütz, E. L. Logee & Co.; J. A. Cheney, Ludwig Nissen & Co.; Mr. Hart, Mt. Washington Glass Co.

The Waltham Watch Tool Co. have won their suit against the Dickinson Hard Rubber Co., of this city. The plaintiffs made some special tools for the defendants and there was a balance which the latter would not pay. Suit was brought, and the special master appointed by the court has returned a judgment of \$791.73 damages, and interest of \$110.31.

H. J. Davison is kept busy trying to identify the men who are arrested in various places, and who have the appearance of being those who played the "red pepper" trick upon him. Last week he went to Hartford to look at George White and Richard Parker, who were arrested there for robbing David Mayer's jewelry store, but they were not the men who interviewed Mr. Davison.

The ostrich eggs offered by Lewis Bros., 41 and 43 Maiden Lane, New York, make, when silver mounted, one of the most unique Easter novelties put on the market in some time. The eggs were part of the African exhibit at the World's Fair, and are especially handsome specimens.



# CLASSIFIED INDEX TO ADVERTISEMENTS.

All Advertisements are entitled to one insertion under proper heading. Extra insertions, \$6.00 per annum.  
Extra Headings, \$12.00 per annum.

	Page.		Page.		Page.
<b>Art Pottery, Bric-a-brac, Etc.</b>		<b>Hotels.</b>		<b>Show Cases.</b>	
Ahrenfeldt, Charles & Son, 50-52-54 Murray St., N. Y. ....	38	Gibson House, Cincinnati, O. ....	24	Smith, B. & W. B., 220 W. 29th St., N. Y. ....	44
Bing, Ferdinand & Co., 106 Grand St., N. Y. ..	38	<b>Jewelers' Findings.</b>		<b>Silver Mounted Ebony Goods.</b>	
Borgfeldt, Geo. & Co., 18, 20 & 22 Washington Place, New York. ....	41	Lind, Thos. W., Providence, R. I. ....	18	Deutsch Bros., 7 E. 17th St., N. Y. ....	2
Haviland & Abbot, 29 Barclay St., N. Y. ....	40	<b>Jewelers' Lamps.</b>		<b>Silver Plated Ware.</b>	
Healey, M. & E., Washington, D. C. ....	38	Hinrichs & Co., 31 Park Place, N. Y. ....	35	Pairpoint Mfg. Co., New Bedford, Mass. ....	5
Hinrichs & Co., 29 & 31 Park Place, N. Y. ....	43	<b>Jewelry Mailing Boxes.</b>		<b>Sterling Silver Novelties.</b>	
Straus, L. & Sons, 42 to 48 Warren St., N. Y. ..	37	Am. Railway Supply Co., 24 Park Place, N. Y. ..	44	Codding Bros. & Heilborn, Attleboro Mass. ....	11
<b>Assayers &amp; Refiners.</b>		<b>Jewelry, Silverware and Optical Cases.</b>		<b>Sterling Silverware.</b>	
Clark, J. L., Philadelphia, Pa. ....	17	Jackson, S. C., 180 Broadway, N. Y. ....	43	Alvin Mfg. Co., 860 Broadway, N. Y. ....	18
Howard, S. P., 33 Maiden Lane, N. Y. ....	44	Steinhaus, Theo. C., 10 Maiden Lane, N. Y. ....	4	Campbell-Metcalf Silver Co., Providence, R. I. ..	2
Schawel, J. & Co., 29 John St., N. Y. ....	44	<b>Jobbers, Watches, Diamonds, Etc.</b>		Knowles, J. B. & S. M. Co., Silversmiths' Hall, Union Square, N. Y. ....	17
<b>Auctioneers.</b>		Allen, Benj. & Co., Chicago, Ill. ....	21	Lewis Bros., 41 Maiden Lane, N. Y. ....	11
American Syndicate of Jewelers' Auctioneers, New York and Washington. ....	2	Brethauer Watch and Jewelry Co., Chicago, Ill. ..	24	Reed & Barton, 37 Union Square, N. Y. ....	23
Comrie, A. J., 182 Broadway, N. Y. ....	42	Cross & Beguelin, 17 Maiden Lane, N. Y. ....	2	Shiebler, Geo. W., Co., 179 Broadway, N. Y. ....	4
Prince, J., 137 Broadway, N. Y. ....	44	Freund, Max & Co., 8 Maiden Lane, N. Y. ....	17	Towle Mfg. Co., Newburyport, Mass. ....	43
Scott, De B. O., 20 Murray St., N. Y. ....	5	Myers, S. F. & Co., 48 Maiden Lane, N. Y. ....	44	Wallace, R. & Sons Mfg. Co., 3 Park Place, ..	6
<b>Badges, Medals, Etc.</b>		Oppenheimer Bros. & Veith, 35 Maiden Lane, N. Y. ....	26	Whiting, F. M. & Co., North Attleboro, Mass. ..	9
Irons & Russell, Providence, R. I. ....	37	Wallis, O. W., & Co., Chicago, Ill. ....	22	Wood & Hughes, 16 John St., N. Y. ....	37
Schlechter, G. A., Reading, Pa. ....	43	<b>Leather and Silver Goods.</b>		<b>Spectacle and Eyeglass Cases.</b>	
Stockwell, E. R., 19 John St. N. Y. ....	43	Deutsch Bros., 7 E. 17th St., N. Y. ....	2	Birmingham, Wm. & Co., 728 Arch St., Phila. ..	44
Willson, Chas. G., Reading, Pa. ....	42	<b>Musical Boxes.</b>		White, W. B. & Son, Boston, Mass. ....	4
<b>Chamois Skins.</b>		Jacot & Son, 298 Broadway, N. Y. ....	2	<b>Stem Winding Attachments.</b>	
Taylor, Ceo. C., 26 Cortlandt St., New York. ..	11	<b>Office Building.</b>		Abbott, Henry, 2 Maiden Lane, N. Y. ....	8
<b>Chronometers.</b>		Cruikshank, E. A. & Co., 176 Broadway, N. Y. ..	43	<b>Tissue Paper.</b>	
Heinrich, H. H., 14 John St., New York ....	26	Diamond Exchange Building, 14 Maiden Lane. ..	19	Dexter, C. H., & Sons, Windsor Locks, Conn. ..	37
<b>Clocks, French, English and American.</b>		Sheldon Building, John & Nassau Sts., N. Y. ..	43	<b>Tortoise Shell Goods.</b>	
Jacques, Chas., Clock Co., 22 Cortlandt St., N. Y. ....	44	<b>Office Furniture.</b>		Potter, W. K., Providence, R. I. ....	5
<b>Diamond &amp; Precious Stone Importers.</b>		Schwartzwelder & Co., New York. ....	29	<b>Tool Manufacturers and Dealers.</b>	
Disselkoen, John N., 19 E. 16th St., N. Y. ..	27	<b>Optical Goods.</b>		American Watch Tool Co., Waltham, Mass. ..	8
Eichenberg, Julius, Providence, R. I. ....	26	Berger, Albert & Co., 47 Maiden Lane, N. Y. ..	44	Bullock, O. W. & Co., Springfield, Mass. ....	36
Falkenau, Oppenheimer & Co., 40 Maiden Lane, N. Y. ....	44	Geneva Optical Co., Chicago, Ill. ....	22	Hardinge Bros., Chicago, Ill. ....	23
Hedges, Wm. S. & Co., 170 Broadway, N. Y. ....	26	Kirstein's, H. E., Sons Co., Rochester, N. Y. ..	11	Logan, A. J., Waltham, Mass. ....	5
Kipling, R. A., Hays Bldg., N. Y. ....	26	Queen & Co., Philadelphia, Pa. ....	10	Moseley & Co., Elgin, Ill. ....	22
Randel, Baremore & Billings, 29 Maiden Lane	27	Spencer Optical Mfg. Co., 15 Maiden Lane, N. Y. ..	42	Oliver, W. W., Buffalo, N. Y. ....	22
Smith, Alfred H. & Co., 182 Broadway, N. Y. ..	26	<b>Paneled Metal.</b>		<b>Trunks and Traveling Bags.</b>	
Tannenbaum, L., & Co., cor. Maiden Lane and Nassau St., N. Y. ....	15	Northrop, A. & Co., Pittsburgh, Pa. ....	8	Crouch & Fitzgerald, 161 Broadway, N. Y. ..	38
<b>Fine Stationery.</b>		<b>Paper Boxes.</b>		<b>Watch Manufacturers.</b>	
Parsons & Greene Co., 18 Murray St., N. Y. ....	5	Warner Bros., Bridgeport, Conn. ....	18	Charmilles Watch. ....	28
<b>Gold and Silver Plating Works.</b>		<b>Pens, Pencil Cases, Etc.</b>		Durrstein & Co., Germany. ....	8
Bo'st id Mfg. & Plating Co., Chicago, Ill. ....	22	The Boston Pen Co., Boston, Mass. ....	4	<b>Watch Case Manufacturers.</b>	
Brunor, Martin & Son, 93 William St., N. Y. ..	38	<b>Patents.</b>		American Watch Case Co., Corbin Building, New York. ....	44
Vallentine's Plating Works, 258 Grand St., N. Y. ....	28	Belt, C. T., Washington, D. C. ....	43	Roy Watch Case Co., 21 Maiden Lane, N. Y. ....	28, 29, 30
<b>Gold and Rolled Plate Jewelry.</b>		<b>Photo-Miniatures.</b>		The Planchamp & Becker Co., Chicago, Ill. ..	24
Foster & Bailey, Providence, R. I. ....	3	Favre, Leon, 107 E. 26th St., N. Y. City. ....	17	Wadsworth Watch Case Co., Newport, Ky. ..	25
Read, M. L. & Co., Providence, R. I. ....	42	<b>Platinum Importers.</b>		<b>Watch Dials.</b>	
<b>Gold Jewelry.</b>		Schawel, J. & Co., 29 John St., N. Y. ....	44	O'Hara Waltham Dial Co., Waltham, Mass. ..	43
Carter, Sloan & Co., 15 Maiden Lane, N. Y. ..	27	<b>Ring Makers.</b>		<b>Watchman's C ocks.</b>	
Johnson, R. M., 67 Washington St., Chicago, Ill. ..	23	Bryant, M. B. & Co., 10 Maiden Lane, N. Y. ..	37	Hausburg, O. E., 41 Maiden Lane, N. Y. ....	44
Krementz & Co., 182 Broadway, N. Y. ....	2	Bowden, J. B. & Co., 192 Broadway, N. Y. ....	19	<b>Watch Importers.</b>	
Pfeil, Chas. H., Chicago, Ill. ....	22	Hildreth Mfg. Co., 53 Maiden Lane, N. Y. ....	8	Hyde's, J. E., Sons, 22 Maiden Lane, N. Y. ..	38
Reddall, John W., Newark, N. J. ....	16	<b>Rubber Stamps and Type.</b>		Mathey Bros., Mathez & Co., 21 & 23 Maiden Lane, N. Y. ....	4
Unger Bros., 192 Broadway, N. Y. ....	12	Dietz, Wm. H., Chicago, Ill. ....	24	Robert, Edmond E., 21 Maiden Lane, N. Y. ....	44
Webster, G. A., Chicago, Ill. ....	8	<b>Sample Trunks.</b>		<b>Watch Keys.</b>	
<b>Horological Schools.</b>		Crouch & Fitzgerald, 161 Broadway, N. ....	38	Clark, A. N., Plainville, Conn. ....	2
American Horological Institute, Lancaster, Pa. ..	23	<b>Watch Repairers.</b>		Muller, Hugo, Chicago, Ill. ....	22
Chicago Watchmakers' Institute, Chicago, Ill. ..	24				
Elgin Horological School, Elgin, Ill. ....	22				
Parson's School for Watchmakers, Peoria, Ill. ..	22				



## Special Notices.

Rates 75c. per insertion for notices not exceeding 3 lines (25 words); additional words 2 cents each. If answers are to be forwarded, postage stamps must be enclosed. Two insertions, 15 per cent. off three insertions, 20 per cent. off; four insertions or more, 25 per cent. off. Payable strictly in advance. Display cards on this page will be charged at \$2.00 per inch for first insertion, subject to same discount as above for subsequent insertions.

Under the heading of **Situations Wanted** on this page advertisements will be inserted for **One Cent a Word**. This offer refers to **Situations Wanted only**. Payable strictly in advance. If answers are to be forwarded, postage must be enclosed.

## Situations Wanted.

Notices under this heading **ONLY** are charged at one cent a word, payable strictly in advance. If answer are to be forwarded, postage must be enclosed.

**WANTED, SITUATION**—Manager of a business for two years past. Do all branches of work—watchmaking, engraving, seal making, jobbing, selling, buying. Box 695, What Cheer, Ia.

**YOUNG MAN** wants position where he can learn the jewelers' trade. Good engraver; have samples. Good references and industrious. Address Engraver, care of THE JEWELERS' CIRCULAR.

**SITUATION WANTED** as watch and clock maker; also jewelry repairer; age 21; speaks English and German; good references. Address A. Guenther, 875 Sixth Ave., New York.

**TRAVELING SALESMAN** with established trade wants two manufacturers' lines on commission to sell retail trade. Address "E," care THE JEWELERS' CIRCULAR.

**POSITION** wanted as watchmaker, salesman and engraver; full set of tools and best of references; single; location no object, but must be a permanent position. Address H. B. G., care of THE JEWELERS' CIRCULAR.

**ENGRAVER AND JOBBER**.—Plain and ornamental engraver wants position where he can learn jewelry jobbing. Can do some gilding and etching; work low. Address Reliable, care of THE JEWELERS' CIRCULAR.

**BY** competent, first-class watchmaker, 30 years of age; strictly temperate. Can do jewelry jobbing and clock work. Good set of tools, lathe and attachments. Had present position about 3 years. Best of reference as to character, etc. Those wanting cheap man need not apply. Please state salary in first letter. R. Jandon, 55 E. Town St., Columbus, O.

**SITUATION WANTED**—By a young man, 23 years of age, as watchmaker and engraver, and salesman. Am a good all round man for store and have good references and full set of tools. Address O. R. F., 403 N. 4th St., Steubenville, Ohio.

**WANTED**—Position by a young man aged 22 years. Can do clock, watch and jewelry repairing. Best of references. Address C. W. P., 413 S. Main St., Waterbury, Conn.

**BY** YOUNG MAN, single, eight years' experience as jeweler, also do clock repairing and wait on store. No bad habits. Best references. Address 8, 2 W. Baltimore St., Baltimore, Md.

**SITUATION WANTED** by young man, single, age 27, as watchmaker, jewelry jobber and plain engraver. Address W. M. M., care of THE JEWELERS' CIRCULAR.

**SITUATION WANTED**—By young man, 18 years old; place to learn jewelers' trade; references. Address F. A. M., 220 Cook Ave., Meriden, Conn.

**SALESMAN** with a large personal acquaintance with retail jewelry trade in Buffalo and vicinity wishes to represent a few manufacturers on commission. Address Reference, care THE JEWELERS' CIRCULAR.

**SITUATION WANTED** by an A1 watchmaker jewelry jobber and engraver. Can repair repeaters, chronographs and all other fine watches; 16 year at the bench; good salesman; sober and reliable; good set of tools; A1 references. Address P. B. L., P. O. Box 412, Winchester, Ill.

**SITUATION WANTED** by a practical jeweler; ten years' experience. Address E. V., 672 Shober St., Chicago, Ill.

**WANTED**—Position as salesman, or watchmaker and jeweler. New York city preferred. A1 references. Address V, care of THE JEWELERS' CIRCULAR.

**YOUNG MAN** wishes position as second watchmaker. Can do ordinary watch, clock and jewelry repairing. Has tools and is competent. Address R. B., care of THE JEWELERS' CIRCULAR.

**A STUDENT** who desires to work and to attend college is open for any proposition. Address Kaylor, 239 E. Main St., Galesburg, Ill.

**SITUATION WANTED** by a young man who has had three years' experience at watch, clock and jewelry repairing. First class references. Address P. O. Box 249, Castleton, N. Y.

**A COMPETENT WATCHMAKER** would like a position; 18 years' experience on fine and complicated work; perfect set of tools. Address Curtis, care of THE JEWELERS' CIRCULAR.

**WATCHMAKER AND JEWELER** of seven years' experience desires position to represent a good tool and material house on the road. Address C. E. Oeth, Spencer, Ind.

**SITUATION WANTED** by a person thoroughly acquainted with diamonds and precious stones. Position to travel preferred, being acquainted with the trade from Boston to Denver, or would accept a position in a large retail house as salesman in diamond department; satisfactory references. Address S. Y. N., care of THE JEWELERS' CIRCULAR.

**WORK WANTED FOR JEWELERS, SILVERSMITHS, ENGRAVERS, DESIGNERS, WATCHMAKERS, CASEMAKERS, TOOLMAKERS, ETC. ONLY WORKMEN WITH GOOD TESTIMONIALS FROM PREVIOUS EMPLOYERS ARE RECOMMENDED.**  
ADDRESS,  
**JEWELERS' RELIEF ASSOCIATION,**  
11 MAIDEN LANE, N. Y.

## To Let

**TO LET**.—A large office, 20x40, first floor, No. 11 Maiden Lane. \$60 a month.

**TO LET AT LOW RENT**—Two very desirable offices, one and two flights up, in building, No. 12 Maiden Lane. For particulars apply to Lissauer & Co., 12 Maiden Lane, N. Y.

**FOR RENT** in Corbin building, 11 John St., sixth floor, half of an office with or without large safe convenient for jeweler. For further particulars, address the janitor of the building.

**BROADWAY STORE** near the Post Office; desirable location; moderate rent; lease. Apply on premises, 2 Astor House.

**CORNER STORE TO RENT**, No. 20 Maiden Lane. Possession May 1st. Terms reasonable. Inquire Room 9, above store.

## Miscellaneous.

**I BUY JEWELRY STOCKS**—Manufacturers, jobbers and retailers desiring to dispose of surplus or entire stocks of diamonds, watches and jewelry can find quick cash buyer by addressing Stephen S. Harmon, 134 East 96th St., New York City.

## DEMAGNETIZING.

**PERFECT WORK**—Watch repairing in all its branches; all work warranted. Winslow & Penney, 608 Masonic Temple, Chicago.

**FOURTEEN** karat gold solder that will flow on eight karat work; makes a hard solder job a pleasure. With this solder there is no danger of melting low karat specs. No white joints on rings. It is just what you want. Sample by mail 25 cents. F. W. Hall, Sterling Silver Novelties, Columbus Memorial Building, Chicago, Ill.

**WANTED TO PURCHASE**.—Good paying jewelry store for cash in New York or Brooklyn. Address L. B., care THE JEWELERS' CIRCULAR.

## For Sale.

**FOR SALE**.—A first class polishing lathe; all in good repair, at a low price for cash. Address G. W. Brown, 113 Point St., Providence, R. I.

**FOR SALE**.—Stock and fixtures of fine jewelry store in the booming city of Niagara Falls. To the right man, a chance of a life time. Enclose stamp for particulars to Dr A. Bowen, Medina, N. Y.

**\$450** buys a stock of jewelry and fixtures in a town of 1,000 inhabitants; no other watchmaker within 25 miles of me. Address at once C. R. Keil, Thorpe, Wis.

**FOR SALE**.—A first-class jewelry store in a city of 10,000 inhabitants, southern Pennsylvania; large, roomy store with two plate glass front and side show windows, 5x5 by 10 feet high; a nice clean stock, fixtures almost new. Will invoice \$5,000; can be reduced to \$3,500; over three fourths of stock consists of staple goods; good run of bench work; must be sold at once; a good discount allowed to cash purchaser. For full particulars address Good Chance, care THE JEWELERS' CIRCULAR.

**A FINE CHANCE** in Washington, D. C.—Having been called away from the city by reason of sickness will sell my watch and clock repairing business at a low figure; it consists of a large safe, large regulator, show case, counter, two benches, two watch racks, crystal case, material box and contents, show watch, signs, and a small stock of jewelry, located on the principal business street; rent \$15 per month, paid to April 1st; immediate possession given; repairing varies from \$25 to \$35 per week; considerable work on hand to be called for; everything in good shape to sit down at the bench and go to work; a reliable apprentice, who understands cleaning and repairing, will remain if wanted; price \$250. Address Jeweler, 612 G St., N. W., Washington, D. C.

## TO LET.

One of the most desirable Offices

— IN THE —

**HAYS BUILDING,**  
21 and 23 MAIDEN LANE.

APPLY AT OFFICE OF THE BUILDING.

**\$5,000** for long established retail Jewelry business in city of 100,000 inhabitants;

**YEARLY PROFIT ABOVE EXPENSE, \$3,500.** Can be greatly increased by additional capital if desired.

Satisfactory reasons for selling given to parties with necessary cash capital. Address, CHANCE—care of THE JEWELERS' CIRCULAR.

## SAFES FOR SALE.

(CHOICE OF TWO.)

Will sell at one-fifth the original cost; size, 56x38 inside measure. A ply to or address,

## OPPORTUNITY,

Care THE JEWELERS' CIRCULAR.

# SHELDON BUILDING,

S. E. CORNER JOHN & NASSAU STS.

A few offices remaining in this modern fire-proof building can be had at moderate rates. Excellent light, two rapid running elevators and all modern improvements. For plans and particulars apply to

**GEO. R. READ, AGENT,**

9 PINE STREET, = = NEW YORK.



**The Latest Patents.**

ISSUE OF MARCH 6, 1894.

**515,745. HAIR-PIN.** TOWSON CALDWELL, Wash-  
ington, D. C.—Filed Sept. 20, 1893. Serial No.  
485,945. (No model)

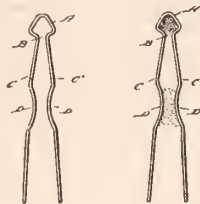

A hair pin comprising an open arrow shaped head A, the walls of which are contracted to form an open narrow throat B, and limbs C and C diverging from the lower walls of the open head and crimped at D.

**515,777. TABLE-KNIFE.** REINHOLD KROHN,

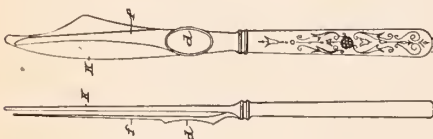

Sterkrade, Germany.—Filed June 28, 1893. Serial  
No. 479,043. (No model.)

**515,835. METHOD OF MAKING KNIVES OR  
KINDRED ARTICLES OF CUTLERY.** ED-  
WARD C. LOMBARD, Meriden, Conn., assignor to  
C. Rogers & Bros., same place.—Filed May 15  
1893. Serial No. 474,283. (No model.)

A method of making knives and kindred articles of  
cutlery, comprising the formation of a blank having a  
handle-portion and a short blade-portion, the said por-

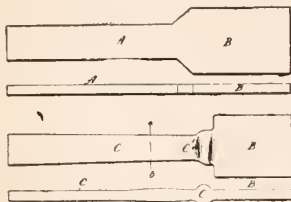

tions being well defined from each other, and the handle  
portion approximating to the form of the handle to be  
produced, then subjecting the handle portion of the  
blank to edgewise pressure throughout its length to  
develop it by thickening it and rounding its edges and  
to form a rudimentary bolster, and then rolling and  
trimming the blank to complete the development of  
the article.

**515,856. CLOCK-PENDULUM.** OTTO BARTEL,  
New York, N. Y.—Filed July 12, 1893. Serial No.  
480,205. (No model.)

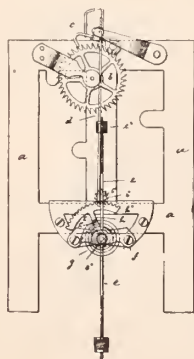

The combination, with a swinging rod having its  
center of gravity below its pivotal point to act as a  
pendulum of a balance spring secured to said rod, co-  
operating with the same.

**515,861. ART OF MAKING DUPLEX ES-  
CAPEMENT-WHEELS.** HERMAN J. EISEN  
Brooklyn, N. Y., assignor to Edward A. Locke,  
Brookline, Mass.—Filed June 28, 1893. Serial No.  
479,067. (No model.)

The method of making hard metal scape-wheels for  
duplex escapements which consists in providing a blank  
with a hub-projection an annular flange and a wide  
margin external to said flange by turning, produc-  
ing the cross and rim, except as regards the peripheral sur-  
faces of the latter, and also roughing out the long  
teeth by a punching operation, cutting all the teeth in  
the stack by cuts extending inward through said flange,  
milling off the functionless remnants of said flange,  
and finally drilling the hub.

**515,862. DUPLEX ESCAPEMENT WHEEL**  
HERMAN J. EISEN, Brooklyn, N. Y., assignor to  
Edward A. Locke, Brookline, Mass.—Filed June  
28, 1893. Serial No. 479,068. (No model.)

As a new article of manufacture, a scape-wheel for  
duplex escapements having long teeth in the plane of  
its rim, and intermediate impulse teeth, of extra width  
from bottom to top, which project bodily from the per-  
iphery of said rim, and extend upward to a second  
plane.

**516,085. RINGING MECHANISM FOR  
BELLS.** WALTER H. DURFEE, Providence, R.  
I., assignor to United States Tubular Bell Com-  
pany, Methuen, Mass.—Filed Aug. 1, 1893. Serial  
No. 441,816. (No model.)

In a ringing mechanism for bells, the combination  
with a bell and a hammer therefor, of a pivoted lever  
connected with and to move said hammer, an actuator  
therefor, and a weight carrying rod connected with  
said lever and passed outside its fulcrum, and a weight  
on said rod to operate.

**DESIGN 23,097. SPOON.** ERNEST W. CAMP-  
BELL, Providence, R. I., assignor to the Campbell-



Metcalf Silver Company, same place.—Filed Jan.  
27, 1894. Serial No. 498,254. Term of patent 3½  
years.

**DESIGN 23,098. SPOON.** BENJAMIN B. FREE-  
MAN, Cambridge, Mass.—Filed Jan. 6, 1894.

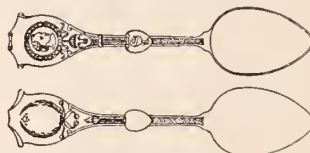

Serial No. 496,007. Term of patent 3½ years.

**DESIGN 23,099. SPOON.** CYRUS BERRY PEETS,



New Haven, Conn.—Filed Nov. 3, 1893. Serial  
No. 489,970. Term of patent 7 years.

**Expired Patents.**

EXPIRED MARCH 6, 1894; GRANTED MARCH 6, 1877.

**188,058. GLAZIERS' DIAMOND HOLDERS.**  
J. E. KARELSEN, New York, N. Y.—Filed Jan.  
29, 1877.

A glazier's diamond holder in which the breaker is  
rigidly attached to handle, while the socket is swiveled

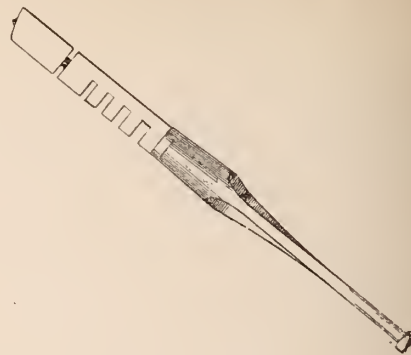

to the end of the breaker.

**188,110. THIMBLES.** W. DURAND, Newark,  
assignor to Durand & Co., Newark, N. J.—Filed  
Feb. 12, 1877.

The thimble having the ball-shaped top or end B, at-  
tached to the base A.

**188,177. SLEEVE BUTTONS AND STUDS.**  
G. PITTS, Providence, R. I., assignor of two-thirds  
his right to J. L. Mason and G. L. Mason.—  
Filed Feb. 9, 1877.

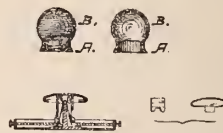

The combination, with the flattened tubular post  
provided with interior shoulders, and the flat shank  
provided with locking springs, of a base spring within  
the post.

**The Business of Edward Eaves to be  
Liquidated.**

MONTREAL, Can., March 9.—In the case of  
Edward Eaves, insolvent, the curator, W.  
O. Lambly, presented a petition in the In-  
solvency Court, asking permission to con-  
tinue the business and liquidate it. The  
Montreal Watch Case Co. presented a pe-  
tition, urging that an offer made by Fancher,  
Fils & Cie., be accepted.

The petitions were heard by Judge Char-  
land, as reported in last week's CIRCULAR,  
who ordered a meeting of the creditors to  
be called. The arguments were continued  
to-day, the curator presenting a report of  
the meeting of creditors. Judgment was  
given dismissing the petition of the Mon-  
treal Watch Case Co., and granting the  
petition of the curator.

**FOR SALE.**

The Old Established Jewelry Business of G. A.  
SCHULTZ (Dec'd), is for sale at a great bargain.  
New fixtures throughout; good location. Address  
**HELENA SCHULTZ, Ex'trix,**  
Corner 7th & Market Streets, LOUISVILLE, KY.

**FACTORY AND OFFICE TO RENT  
FROM MAY 1ST.**

Desirable office on first floor with factory on fourth  
floor. John St., between Broadway and Nassau St.  
Office, 25x40; factory 25x75. Both connected by ele-  
vator and speaking tube. Factory well lighted and  
ventilated by four high sky-lights. Steam power  
according to wants. Rent \$2,000, or factory alone \$1,000.  
Address A. B. care JEWELER'S CIRCULAR



### New Method of Connecting Hand-setting Device.

THE improvements in hand-setting arrangements of stem-winding watches in Europe were hitherto directed almost exclusively to the interior mechanism of the hand-setting device only; otherwise the throwing into depthing of the hand-setting was always effected either by a pressure upon a special button, displacing or drawing out a lever, or else by pressing in or pulling out the winding button. In the following described arrangement, patented by J. Varrin Comment, in Porrentruy,

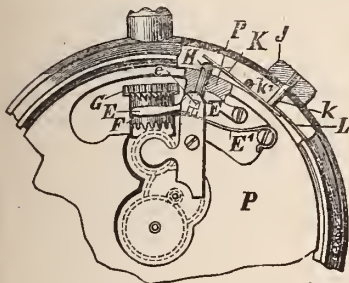

FIG. 1.

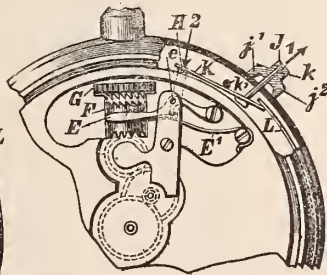

FIG. 2.

Switzerland, in that country and Germany an entirely novel device is used. The connection is established if an elongated piece, the so-called turn-key, on the case rim is turned at a right angle to its position of rest; the hand-setting arrangement then remains in depthing as long as this turn-key is left in that position.

Accompanying illustrations show the mechanism: Fig. 1 being the hand-setting in a disconnected condition, while Fig. 2 shows it in depthing. G is the winding pinion; F the loose hand-setting pinion, with the usual depthing lever E, which gears in a groove of the loose pinion F and stands under the pressure of the spring E. The latter forces the setting pinion E into its locking position, in which it stands out of depthing with the hand-setting device, while the maintaining power is thrown into depthing, as shown in Fig. 1.

In a radically drilled hole of the plate P is the slide H. This is furnished with an incision, into which reaches a pin *e* in the lever F. In place of the usual push button, the watch is furnished with the above men-

tioned turn-key J, which is hollowed out inside in its direction of length, as shown in Fig. 2, where the turn-key is shown in cross section and as standing across the case rim. If this key stands in the direction of length of the case rim, as it does in Fig. 1, its hollow interior lies smooth upon the case rim, and the two edges  $j^1$  and  $j^2$ , Fig. 2, occupy the case rim. When, however, the turn-key is turned 90°, that is, at right angles to the case rim, in the position of Fig. 2, the edges  $j^1$  and  $j^2$  rise upon the higher central part of the case rim, that is, the turn-key J is removed from the center of the case in the direction of the arrow 1, Fig. 2.

In the central part of the case is, next, a double lever K, which revolves around the point *k*. One of the arms of the lever is firmly connected with the turn-key J, the other lies permanently upon the extreme end of the slide H. When the turn-key lies lengthways on the case rim, the spring E<sup>1</sup> becomes effective and throws the loose pinion out of depthing

with the hand setting device. If, however, the turn-key is moved in the position of Fig. 2, at right angle to the case rim, the upper arm of the double lever K displaces the slide H in the direction of the arrow 2, thereby presses the hand-setting lever E to the interior, and places the hand-setting device into depthing. The hands having been set, it is only necessary to return the turn-key J into its usual position, and all the different parts resume their locking positions.

### Material for Polisher.

THERE are many different opinions as to what is the best metal for polishers, and, as polishing is an art, the opinions may be all right; but the general principle may be taken as true, that the article polished must be harder than the polisher, but how much harder will depend on the article polished. If a piece of hard steel with a large flat surface is to be polished, diamantine would now be used to finish with a block, or with a polisher of zinc, or some compound of zinc and tin. I think pure tin is preferable, as any admixture of tin with the zinc makes the block too soft, and the work will be easily rounded, although, if a very little diamantine is used, a very few rubs will complete the polishing, and need not round the work if it has already been flat and square. But polishers for small surfaces, such as pivots, cannot be made of metal as soft as zinc, as they would soon lose their shape and spoil the shape of the pivot; therefore, some men use bell metal and others brass polishers for small pivots, and depend on the bur- nisher for the ultimate finish.

### Workshop Notes.

**Sage Remarks.**—A good watch is not safe in the hands of a workman who is either careless or unacquainted, as many are, with the very rudiments of the trade they profess. There is no excuse for this prevalent and increasing ignorance, considering the number of text books and other sources of information available to anyone anxious or even willing to learn. It is really grievous to see the number of good watches that are spoiled by repairers who neither understand what they profess to do, nor could if they understood.

**Pivot Polishing.**—The polisher used for a pivot may be oblong or square. The first is the best form, with the edge next the shoulder sloped off at such an angle that the edge of the polisher will always get to the corner of the pivot and shoulder. This side of the polisher may be straight or a little convex, and both face and edge of the polisher kept sharp by repeated filing up with a sharp but not a coarse file, as using a polisher until it is quite smooth only puts the work out of shape and rounds the shoulder.

**To Put a Watch in Beat.**—To put the lever watch in beat the most perfectly, wind the spring a quarter or half turn, and stop the balance with a tooth of the wheel on the impulse face of the pallet; allow it to pass off, and note the stopping point on the other pallet; if not equal, make them so, or if difficult to get just equal let it pass off the entrance pallet the freest. Same with the cylinder escapement; if not equal, let the tooth pass freest going into the cylinder, rather than out of it. A duplex will be very nearly in beat if starts off letting go the balance at the point of first and third drops. A chronometer should start off letting go the balance at the point where the jewel passes away from the gold spring, and where the tooth passes off the pallet.

**Turning Pivots.**—When turning a pivot it is necessary to see that the turns are in proper order, that the runners fit well, and are easily fixed, and that the centers for the pivots to run in are as deep as possible. The height of the rest must be carefully looked to, but the height at which to fit it will be governed by the size of the graver used. The rest should be close to the work, and at such height that the edge of the tool will be opposite the center of the piece turned, as, if it is higher than the center, it will not cut freely, and if below, the risk of breaking either the tool or the pivot will be much increased. Pivots should be turned to very nearly the required size with the graver, and if it be a pivot with a shoulder, the pivot made quite straight and the shoulder square before using the polisher, as a little lump in the corner can only be got out with a polisher by a very practised hand. Hard hammered black steel is best for polishers, which, for small pivots, should not be large.

### FOR JEWELERS' USE.

G. A. Kleemann's Patent Improved Student Lamp.

C. A. Trade Mark.

#### THE GERMAN AMERICAN.

It preserves all the improvements which have made the St. Germain Student Lamp so acceptable to Watch-makers and Mechanical Jewelers, but is a much larger Lamp, fitted with a nine-inch shade and its new large burner—far superior to that of the St. Germain—gives a light nearly double in brilliancy.

Steady white light, perfect combustion, without much heat, safe against explosion.

Will last a lifetime. Wick easily adjusted. Illustrated circular free.

HINRICHS & CO.,  
29, 31 & 33 PARK PLACE,  
NEW YORK CITY.





# SUGGESTIONS FOR WINDOW AND STORE DECORATION.

Members of the trade who think they have an attractive window are invited to send us a photograph, or a pen and ink or pencil sketch of the same, which will be published if we consider the window contains any originality or lesson.

## IDEA LXVIII—EASTER WINDOW.

**T**HE illustration herewith depicts the Easter design to be used in the window of Boettinger & Walter, jewelers, Lexington St., Baltimore, Md., conceived by H. J. Sahn. The bottom of the window is covered with black velvet, and in the rear is a raised piece eight inches high, in the shape of a half circle, covered with same

shades and candles, the rest of the display being made up of silver belts and a few watch cases.

In front of the raised piece in the center of the window is a large egg made of white cotton, with the word Easter composed of brooches in enamel and diamond patterns; on the top of the egg is a figure of a little

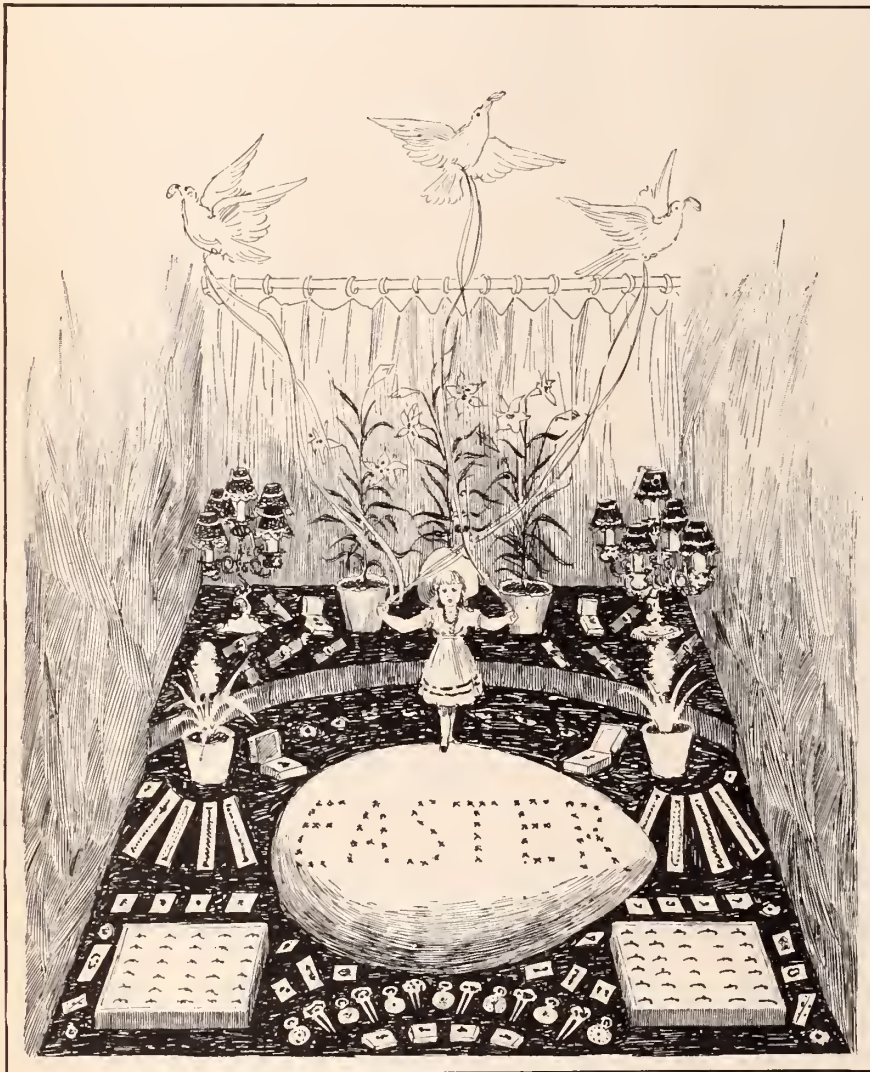

material as the bottom; on this are three pots of lilies forming a centerpiece; to the right and left of this are candelabra with

## NEW CLOCK STAFF WRENCH.



This entirely new and most useful tool is for setting up clocks, particularly fine and costly ones. Can remove pivots at ease. No chance of displacing other pivots in the operation. For description, send 5c. in stamps for catalogue of over one thousand varieties of fine tools.

O. W. BULLOCK & CO., Springfield, Mass.

girl with a diamond headpiece and neck chain and pendant in diamond goods. Above all are three doves, about 6 inches from the front glass, posed in upward flight. They have diamonds attached to their necks, and a small white ribbon runs from the birds to the figure on top of the egg. Hyacinths, two ring trays in front, and some Easter cards, prayer book markers, and choice goods make up the rest of this Easter window.

The store of S. A. Cole, Sand Bank, N. Y., was burned out Thursday night.

## Trade Gossip.

E. Kirstein's Sons Co., Rochester, N. Y., want the trade to know they have an optical "gem" in their Columbia, illustrated and described on another page. The objectionable feature of the old style adjustable eyeglass, so largely in use, is the breaking of the bottom guard. In the Columbia the spring power is placed at the top, while the bottom is hinged, thus eliminating entirely all the bad points in the old eyeglass.

A positively new and timely novelty has just been introduced by Unger Bros., Corbin building, Broadway and John St., New York. It is known as a lady's collar buckle, and is especially suitable for the high collars now in vogue. The buckle is of sterling silver and is shown in over a dozen different patterns, among which are some in open pierced work, and others with open centers and scroll borders. They are made so that they can be used with a ribbon or fastened directly upon the collar. This article, which is an entire novelty and is very appropriate to the present style in ladies' dress, cannot fail to be popular from the start.

The following letter from John Stork, 142 Fulton St., New York, is another representative testimonial of the book of Martin Brunor, and needs no comment:

MR. EMILE BRUNOR:

DEAR SIR:—Before I purchased The Practical Electroplater, I had never handled chemicals, and had no faith in the value of books as instructors. My experience with your invaluable book has entirely changed my views, for since receiving it I have fitted up my shop for gilding, oxidizing and silver plating, the work occupying three days at an outlay of about \$25. By following the directions of the Practical Electroplater I have been enabled to oxidize 300 medals in 15 minutes in an entirely satisfactory manner, besides being able to successfully gild both matt and bright. My silver plate apparatus works satisfactory. My ability to do the work myself enables me to guarantee the durability to my customers, and to do it more quickly than with my former methods. I can, with great satisfaction, recommend the book to all manufacturers and will gladly show my apparatus to any person in the trade.

Yours truly,

JOHN STORK.

Some of the features of the novelty used in the demonstration of refraction in the monthly sessions of the Spencer Optical Institute, known as Heath's Refraction Board, as to form of eye ball myopic, emmetropic and hypermetropic with dial indicators to show the exact amount of the above in dioptries from  $\frac{1}{4}$  to 8 dioptries: Accommodative crystalline lens changes, with indicator, also corneal curvature changes in both horizontal and vertical meridians with indicator; the rays of light entering the eyes in shaded silk, red for horizontal; yellow for vertical; these are rendered parallel, convergent or divergent by touching the button, and the exact amount of convergence or divergence is indicated in dioptries on dial; when model is thrown in error by thumb buttons, the exact amount of the error is indicated on various dials. This novelty will be on exhibition in the Spencer Optical Mfg. Co.'s show windows after March 15th.



# RUDOLSTADT

## ART POTTERY

**HIGHEST AWARD WORLD'S COLUMBIAN EXPOSITION.**



**C**ONTAINS all the elements required as to designs, decorations and workmanship, in a high grade of Art Goods adapted to the Jewelry Trade, and yields a larger margin of profit than any other class of Pottery.

**L. Straus & Sons,**  
SOLE AGENTS,  
42-44-46-48 Warren Street,  
116 Chambers Street,  
NEW YORK.

**WOOD & HUGHES,**  
STERLING SILVERWARE MANUFACTURERS  
New York Agents for the Derby Silver Co.'s  
FINE QUADRUPLE PLATED WARE,  
No. 16 JOHN STREET, NEW YORK.  
206 Kearney St. San Francisco, Cal.  
HASKELL & MUEGGE, Agents.



**IRONS & RUSSELL,**  
(SUCCESSORS TO CHARLES F. IRONS.)  
MANUFACTURERS OF  
**SOLID GOLD EMBLEMS ROLL PLATE**  
PINS, CHARMS AND SOLID GOLD RINGS.  
102 Friendship Street, - - Providence, R. I.



# The "Bryant" Rings.

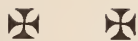

Are widely advertised and will sell when anything will, therefore every Retail Jeweler should buy them.

IF NOT CALLED UPON BY OUR TRAVELERS  
ORDER DIRECT FROM

**M. B. BRYANT & CO.,** 10 MAIDEN LANE, N. Y.  
OLDEST RING MAKERS IN AMERICA.



**THE QUESTION** ?  
WILL IT TARNISH ? Need  
not be asked if your Tissue Paper bears this label.

MANUFACTURED BY  
**C. H. Dexter & Sons,**  
WINDSOR LOCKS, CONN.

◁ BE SURE YOU GET THIS BRAND. ▷

It has been adopted and is now used by the leading manufacturers of this country.



# FERDINAND BING & Co.,

106 GRAND ST., N. Y.

❁ ————— NEW DESIGNS IN ————— ❁

China Clocks and Gilt Bronze Sets, Fine Painted Dresden Goods in  
Vases, Cups and Saucers, and Plates; Cararra Marble Statuary,  
French Cabinets and other Fancy Furniture.

MARTIN BRUNOR & SON,

## Electroplaters,

Expert work done on Solutions and Chemicals  
when desired.

We beg to call attention to the fact that the only persons in our line named Brunor constitute this firm. Martin Brunor has removed his Tools, Machinery and Solutions from 32 Maiden Lane to 93-7 William Street, the Black Building. Used by any other concern, the name Brunor is only a trap for the unwary, who may be led to believe that the members of this firm are connected with it.

MARTIN BRUNOR & SON.

## Jules Jürgensen

OF COPENHAGEN.

*The reputation these watches have maintained for Fifty Years has never been equalled, being made on strictly scientific principles and no expense spared to give the Best results in mechanism and timekeeping qualities.*

SOLE AGENTS.

John C. Hyde's Sons,  
NO. 22 MAIDEN LANE.

## CROUCH & FITZGERALD.

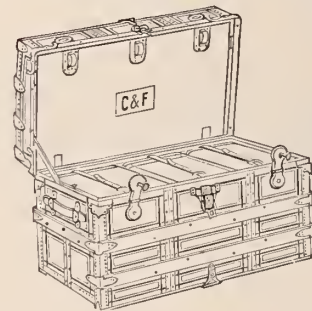

Jewelry Trunks  
and Cases.  
161

Broadway,  
Bet. Cortlandt and  
Liberty Sts.,  
688 B'way,  
701 6th Ave.,  
NEW YORK.

## LEGENDS OF GEMS.

BY FRANK SHELLEY.

Gilt edged; bound in leather; a perfect specimen of the printer's and binder's art. Should be in every jeweler's library. Price, \$1.00. For sale by

THE JEWELERS' CIRCULAR PUB CO.

## OUR IMPORT LINES OF

# CHINA, GLASS and BRIC-A-BRAC

..... ARE COMPLETE .....

WE CALL PARTICULAR ATTENTION TO THE FOLLOWING SPECIALTIES:

LIMOGES CHINA AND SAXONIA WARE, ROYAL DRESDEN CHINA, SEVRES PORCELAIN,  
PARIS NOVELTIES, VIENNA CROWN WARE, ROYAL BONN AND DELFT  
FAIENCE, AUSTRIAN GILT GLASS.

# CHARLES AHRENFELDT & SON,

50, 52 & 54 MURRAY STREET, NEW YORK.





## The Empire Style in Industrial Art.

THE Empire style having penetrated into the realms of all articles of luxury, a study of the artistic lines of the period from which the style derives its name will prove most interesting. Particularly true is this of the clocks, bronzes and the various ceramic lines, in which, from present appearances, the Empire style bids fair to be as popular as at the time of its inception. Though probably unknown to many persons most interested in the subject, an opportunity has lately been afforded New Yorkers to examine some of the most artistic productions in mantle clocks of the time of Napoleon. This collection, in which the two clocks depicted in the illustration form a part, is in the possession of Chas. H. Huber & Bro., 174 Third Ave., New York, and is one of the finest and richest assortments of these clocks ever exhibited in the metropolis.

The collection affords some of the most striking and interesting interpretations of the Empire style. The pieces were nearly all manufactured during the later years of the First Empire and are thoroughly representative of the style of that period. The clocks were collected in France and Italy by the Comte de Forrest. Most of them had been especially made as political gifts, and the Count was only enabled to obtain possession of them, one by one, from the families of the nobility during the reverses and vicissitudes that followed the downfall of Napoleon.

The collection was exhibited at the World's Columbian Exposition by the heirs of the Count, who placed it at a very high figure and refused all opportunities of selling the clocks singly, preferring to preserve the collection in its entirety. At the close of the World's Fair the collection was purchased by Charles H. Huber & Bro. The pieces are in real mercury gilt, which process of gilding is characteristic of the style of the Empire period. Aside from their interesting history and associations, they form a valuable and prolific source of ideas, not alone to the manufacturer of clocks and bronzes, but also to the workers in ornamental brass and ormolu, so much in vogue

the present day. A number of most interesting photos of pottery—ancient and modern—were thrown on the screen, showing articles made by potters 6,000 years ago. A Celtic incinerary urn was shown, hundreds of years old, made by hand, without a potter's wheel, and ornamented with the finger nails of the artist. Illustrations of Moorish, Majolica, Japanese and Chinese ware were also shown on the screen, and their special features explained, incidentally remarking that the Japanese artist was the most painstaking and inimitable in the world.

Regarding the dragon, which is such a feature of Chinese decoration, he said that it was regarded as sacred, and there was a legend in China, that once upon a time, while a number of the Emperor's counselors met together, a dragon came and carried them off to heaven on its back—Mr. Fleming adding, amid much laughter,



SPECIMENS OF GENUINE EMPIRE CLOCKS.

at the present time, for trimmings on furniture and interior woodwork.

### Lecture on Pottery.

JAMES FLEMING, chairman of Glasgow School of Art, delivered a lecture on "Pottery," recently at Glasgow. He remarked that the history of art was closely allied to pottery. If the first artists were not potters, they at least exercised their artistic abilities on the work of the potter. Some of the most famous Greek sculptors also worked in clay and modeled the figures and other kinds of ornaments that adorn the peerless Greek vases which are treasured at

that remembering this story, he occasionally wished a dragon would come along and act similarly to counselors of the nation. Coming to more modern days, views of the productions of Wedgwood were shown, and the lecturer remarked that Wedgwood had the true artistic instinct never allowing a piece of ware to leave his pottery which was not of the highest possible excellence. He perfected the crude processes of his predecessors, and brought the potter's art to a stage that has not been improved up to the present time.

J. C. New is a new jeweler in Maynard, Ia.



**The Connoisseur.**

(Continued from page 39.)

**The Rambler's Notes.**

WHAT THE RAMBLER SAW AND HEARD AMONG THE DEALERS IN ART POTTERY, CUT GLASS, BRONZES ETC.

**EASTER NOVELTIES** are now shown in great variety in the wholesale department of A. A. Vantine & Co., 877 Broadway, New York. Easter egg boxes, which comprise the principal of these lines, can be seen in every size from the small ring box to the largest bonbon box, and in apparently every conceivable hue. The decorations which are numerous, show the genius of the Japanese in forming quaint and artistic designs. Easter eggs are shown both in metal, silver plated, with embossed decorations, and in the genuine article, ostrich eggs, either plain or covered with various designs in Japanese gold lacquer. Another line is composed of candy boxes shaped like a broken egg, with a gilt decoration on an ivory ground.

**THE ROYAL CUTTING.** **L. STRAUS & SONS**, 42-48 Warren St., New York, are receiving a full stock of cut glass pieces in their latest pattern, the Royal. This design, a very heavy cutting, is bril-

liant and showy, and is different from other patterns, as it contains no checker work in the design. There are over sixty different cuttings shown at the warerooms of Straus & Sons, forming one of the greatest assortments displayed by any one firm in the metropolis. Another timely line which this firm show contains Easter goods of many kinds, including bisque and glazed flower holders, vases, bonbon boxes and a large assortment of Florina egg shaped baskets.

**THREE POPULAR CUT GLASS PATTERNS.** **T**HE three latest patterns of the Mt. Washington Glass Co., New Bedford, Mass., the Admiral, Monterey and Royal, are to be seen at their New York salesrooms, 46 Murray St. In richness and beauty they conform to the many former cuttings introduced by this company, and are sure to prove as popular as their predecessors. The Royal, which is shown in a full line of pieces, is a very heavy cutting, the salient feature of which consists of points filled in with small squares containing diamonds.

**NEW PRODUCTIONS IN PORCELAIN.** **A** LARGE assortment of ice cream and fish sets in *bleu de four*, are now to be seen at the warerooms of F. W. Büning, 58 Murray St., New York. The fish sets show many very appropriate and attractive designs with various water effects,

showing fish in the waves and in still water. In these and in the ice cream sets the *bleu de four* borders are decorated with many raised and traced gold patterns and scroll designs. In speaking of this color, mention should also be made of some handsome *bleu de four* plaques which are shown in two subjects after Millet, Les Gleneuses and the famous Angelus.

**LATEST PIECES IN HACHE PORCELAIN.** **A**MONG the latest pieces received by Horace Craighead, 33 Barclay St., the New York agent for the china of Alfred Haché & Co., Vierzon, France, are some beautiful hand painted game sets of 13 pieces. The dish is decorated with a group of birds which completely covers the center, while each of the 12 plates contains a different bird of rich plumage painted in natural colors. That these sets will be popular there is little doubt, inasmuch as they are artistic though quite inexpensive.

THE RAMBLER.

A KEEN SCHEME.

"Be sure to remove the price mark," said some purchasers of a wedding present lately to the jeweler. "That isn't always what I am asked so to do," he replied. "You would scarcely credit how often and by what heavy swells I am requested to mark up the price mark and send it in that way." —Boston Herald.



NEARLY A CENTURY OLD.  
E. GERARD, DUFRAISSEIX & CO.,  
SUCCESSORS  
FABRIQUE FONDEE EN 1797

THE  
**CH. FIELD HAVILAND**  
LIMOGES CHINA

IS MARKED:  
WHITE WARE,  
CFH  
GDM  
FRANCE



DECORATED  
NEW GLAZE COLORS  
(FURNACE FIRE),



HAVILAND & ABBOT, {O. A. GAGER & Co.  
CHAS. FIELD HAVILAND & Co.

IMPORTERS OF CHINA,

P. O. Box 505.

29 BARCLAY STREET,

NEW YORK.

AGENTS FOR  
E. GERARD, DUFRAISSEIX & CO.,  
LIMOGES.

NEW YORK OPEN STOCK.

We carry at all times a large assortment of the "Chas. Field Haviland" china in white and decorated goods, to repack for immediate shipment or for sale in original casks. Have now sixteen *open stock* decors and are constantly adding new designs.

IMPORTATION SAMPLES.

The newest and choicest designs always to be found in our import rooms. Novel forms and tasteful decors.

New York Sample Rooms, - - No. 29 Barclay Street.



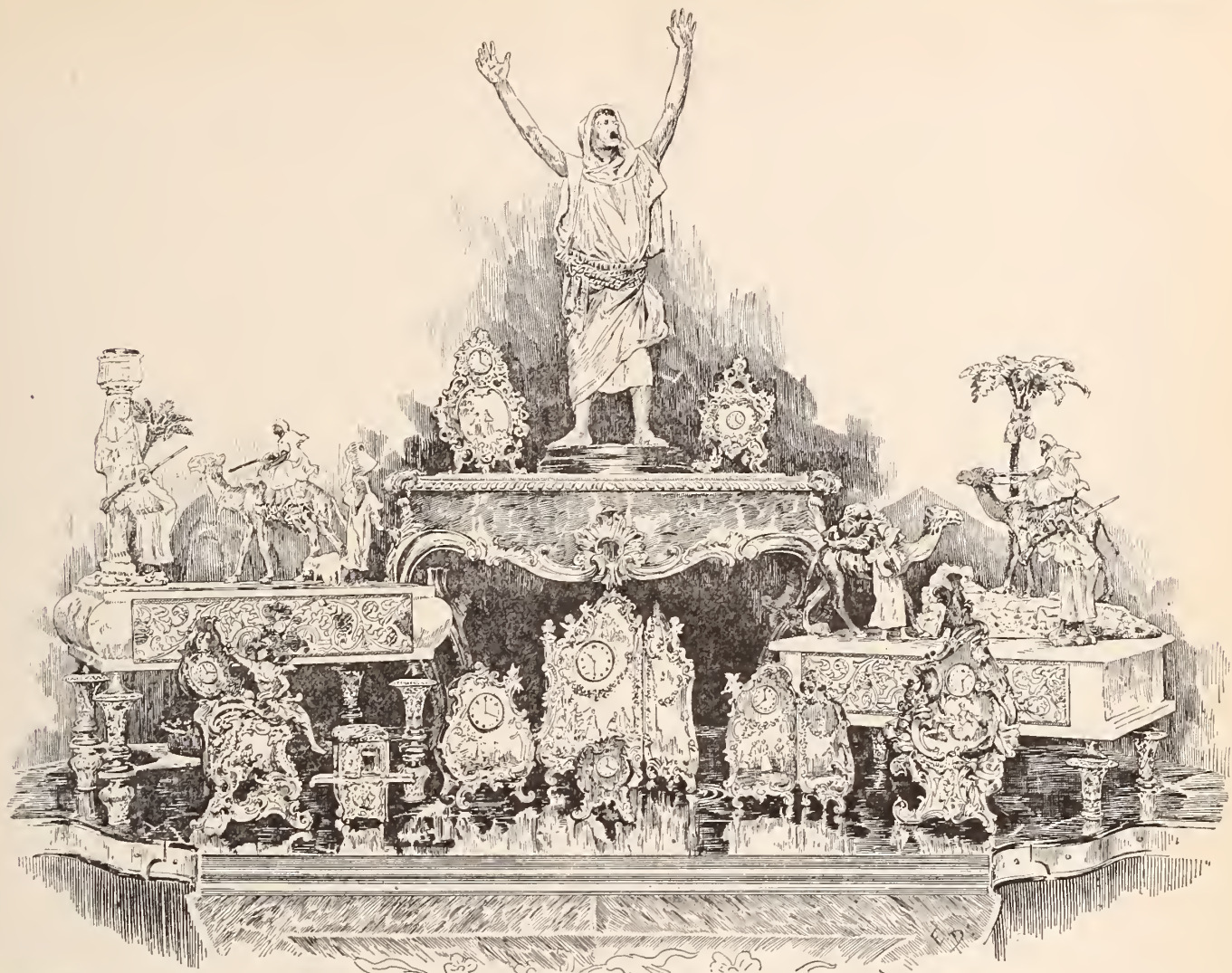

It will greatly interest *Jewelers* and dealers in *Bric-a-Brac*, to see our various assortments of *Fine Art Novelties* which we have imported especially for this trade.

We are very particular to have the *best and latest designs* always in our collections, with the result that we are now showing the *most complete and attractive line of goods ever put on the market*.

Special attention is directed to

VIENNA BIJOU CLOCKS, in exquisite gilt frames of rococo pattern.

VIENNA BRONZES, original in design, perfect in detail.

JEWEL CASKETS, onyx with cloisssonne effect.

## SILVER FILIGREE JEWELRY,

comprising many very effective styles in Scarf, Lace and Hair Pins, Brooches and Breast Pins, Bracelets, Bon-Bonnières, Match Boxes, etc., etc., at prices which insure a ready sale with a good profit.

---

# GEO. BORGFELDT & CO.,

18, 20, 22 WASHINGTON PLACE, Cor. Greene St.,

NEW YORK.



The Other Side of Life.

A LAST RESORT.

LITTLE BOY—I want you to write me an excuse for being late to school yesterday.

JEWELER—Eh? You are not my son.

LITTLE BOY—No; but Mama says I had plenty of time to get to school, so I guess the clock you sold her doesn't go right.—*Street & Smith's Good News.*



1—THAT IS DIFFERENT.

She—I can never marry a shop-keeper.  
He—But mine is a jewelry shop.

TIED AND TIDE.

There are two downtown lawyers who lunch together six days in the week at a restaurant not far from City Hall. They have the reputation of being facetious and are fond of cracking bottles and jokes at the same time. As they crossed City Hall Park recently one of them pointed to the clock on a famous newspaper building. The clock had stopped several hours before. "Who says time waits for no man?" he asked triumphantly. "Yes," commented his companion, pointing to the statue of Nathan Hale, "and there's 'the tied' at a standstill."—*New York World.*

IN AN OLD CHURCH.

ETHEL—How harmonious the color of everything is.

MARGARET—Yes, excepting the sexton. Why doesn't he wear stained glasses?—*P. & S. S. S. Co.'s Bulletin.*

YOUNG GUSHINGTON—Had I the wealth of Croesus I would adorn this fair finger with a diamond as large around as a silver dime.

MISS SIMPERLY—La, Henry, how extravagant! I should be perfectly satisfied with one as large as a nickel.—*Chicago Tribune.*

Possibly the roped arena may represent a serious battle, but any girl knows the kind of an engagement the real prize ring stands for.—*Philadelphia Times.*

POOR BOY.

PROFESSOR SKAGGS—Do you do much reading, Mr. Budd?

CHOLLY—No—aw—twuth is, y' know, I cawn't wead through the monocle at all, and I—aw—don't feel dwessed without it.—*Judge.*

BETTER THAN ELECTRICITY.

AGENT—Wouldn't you like to have a burglar alarm set up in your house?

MR. BINKS—Don't need it. I've got a wife.—*N. Y. Weekly.*



2—THAT IS DIFFERENT.

She—Take me, darling!—*Judge.*



SPECIAL SALESMAN OF

WATCHES, DIAMONDS,

Bric-a-Brac  
and Art Goods

FOR

Established Jewelers.

WRITE FOR PARTICULARS.

Communications Strictly Confidential.

References given in all parts of the United States from Retailers and Jobbers.

Enterprising Jewelers Catch On!



OBVERSE



REVERSE



BACK

Jewish Sheckel, Masonic Mark or Pocket Piece.

THE LATEST AND BEST SELLING NOVELTY.

The mark is struck in coin silver; by using either the obverse or reverse of the coin, the back being the same in either case, and permitting of the purchaser's name, blue lodge, chapter and individual mark, with date of same being engraved thereon, as shown in cut above.

Price, without engraving, ONE DOLLAR. Engraved Mark, Dates, etc., 75c. EXTRA.

Liberal Discount to the Trade.

CHAS. G. WILLSON, MANUFACTURING JEWELER, READING PA.

SPECIAL SALESMAN OF

WATCHES, DIAMONDS,  
Bric-a-Brac  
and Art Goods  
FOR  
Established Jewelers.

WRITE FOR PARTICULARS.

Communications Strictly Confidential.

References given in all parts of the United States from Retailers and Jobbers.

---

Three Great Successes.

Our Industrial School of Optics Practical  
Our Swell Gold Construction Progressive  
Our Prescription Department Punctual

ASSURED SUCCESS TO YOU

If you take the Practical course in refraction, sell The Swell End Eyewire Gold Spectacles and Eye Glasses, and send your Prescription work to our special department which you will find accurate and punctual.

Avoid delay and errors by keeping in mind the old reliable

Spencer Optical M'f g Co.  
15 MAIDEN LANE, NEW YORK.



M. L. READ & CO.,

161 DORRANCE ST.,  
PROVIDENCE, R. I.

THE  
Old  
Reliable  
House

FOR  
STICK PINS AND  
WHITE STONE GOODS



# HINRICHS & CO.,

29 AND 31 PARK PLACE,  
NEW YORK.

## BRIC-A-BRAC and ART POTTERY.

Doulton, Worcester, Royal Vienna, Teplitz, Dresden, Sèvres, Coalport, Austrian Faience, Bisque Figures and Candelabras.

BOHEMIAN AND FRENCH CHRYSANTHEMUM VASES and Bouquet Holders, Atomizers, Cologne Bottles and Jewel Boxes.



### SPECIALTIES IN LIMOGES CHINA.

A. D. Cups and Saucers, Chocolate Cups, Teas and Coffees, Mustache Cups, designs and decorations entirely new and exclusively our own.

OUR SPRING STOCK was never more complete than now, and we never had a finer line of goods. Catalogues and Price Lists on application.

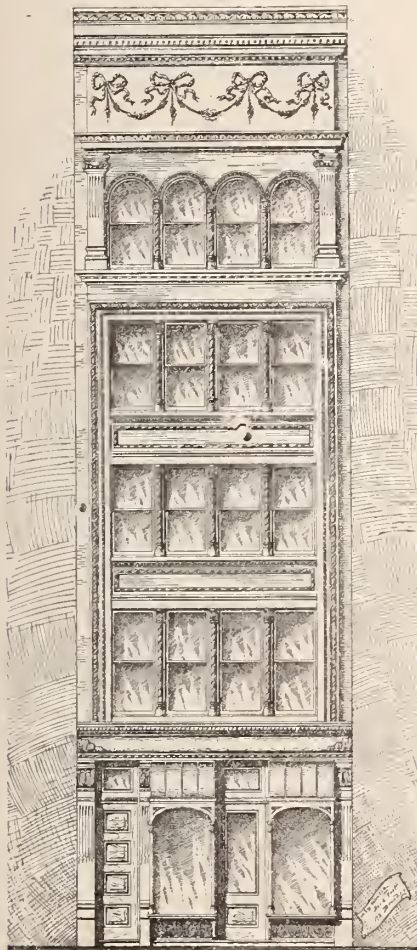

## OFFICES TO LET

BRIGHT AND CHEERFUL,

IN THE

HANDSOME NEW OFFICE BUILDING

45 MAIDEN LANE,

with elevator, steam heat, electric light, best of plumbing and all modern conveniences, at rentals from \$350 up. For further particulars, apply to

E. A. Cruikshank & Co.,

176 BROADWAY, N. Y.

## CHRYSO-CERAMICS,

GOLD COVERED PORCELAIN.

M. & E. HEALEY,

1122 CONNECTICUT AVE.,

WASHINGTON, D. C.

MEDAL AT WORLD'S COLUMBIAN EXPOSITION.



Elk, Shrine and Masonic Emblems a Specialty.

Badges of Every Known Order.

G. A. SCHLECHTER,

Manufacturing Jeweler.

READING, PA

For BADGES AND MEDALS,

Flag Pins, Class Pins, Class Rings and Special Work of all Descriptions.

SEND TO E. R. STOCKWELL, MANUF'R.

19 John Street,

New York.

# ONE FEATURE

OF  
THE JEWELERS' CIRCULAR.

ONE OF MANY,

"Think each article you publish about 'Window Decoration' worth the full price of your subscription."

GEO. E. FEAGANS,  
JOLIET, ILL.

SEE PAGE 36.

### "Old English" Coffee Spoon.

\*\*\*



DESIGN PATENTED.

Towle Mfg. Co.,

MANUFACTURERS OF

STERLING SILVERWARE.

NEWBURYPORT: No. 214 Merrimack St.

CHICAGO: Nos. 149 & 151 State St.

## S. C. JACKSON, 180 BROADWAY, NEW YORK.

MANUFACTURER OF

Fine \* Cases \* for \* Jewelry, \* Silverware, \* Etc.

ALSO SHOW CASE TRAYS AND FANCY HARD WOOD WORK

Samples sent on application. Estimates furnished

FANCY DIALS TO FIT AMERICAN WATCHES.

\$6.00 per doz. IN FLAT SECONDS.

\$7.20 per doz. IN PRESSED SECONDS

Jobbers, Importers and Retailers generally, will be re-bated by sending to us any Dials of our make which they may have on hand.

O'HARA WALTHAM DIAL CO., Waltham, Mass.

## PATENTS SECURED WITHOUT FAIL OR DELAY.

Send Rough Sketch or Model and I will tell you whether you can obtain a patent, WITHOUT CHARGE.

Fifteen years' experience. Ample references. Address

C. T. BELT,

WARDER BUILDING WASHINGTON, D. C.



**B. & W. B. SMITH,**

220 W. 29<sup>TH</sup> ST.,  
NEW YORK.

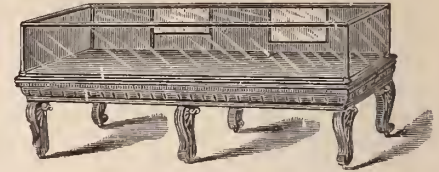
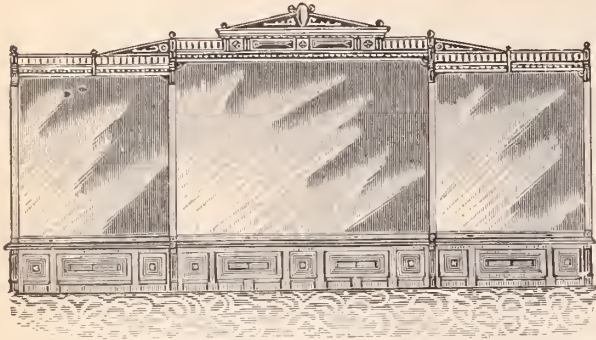

Dust Tight Wall Cases. Improved system of Shelving and Electric Wall and Counter Cases Lighting.

IMPROVED DUST TIGHT.

◁ SMALL CASES FOR SPECIALTIES ▷

ALL GLASS.

NO MOULDINGS

**S. F. MYERS & CO.,**

WHOLESALE JEWELERS,  
MYERS BUILDINGS, - - NEW YORK.

1894 ISSUE, No. 38,

**OUR ROYAL CATALOGUE**

Illustrates all that is new, unique and desirable in everything that pertains to jewelry.  
Sent free to dealers who have not received it.

TWENTY-TWO DEPARTMENTS.  
SEVEN DOUBLE FLOORS.

Myers Buildings, 49-50 Maiden Lane, 33-35 Liberty St., New York.

**S. P. HOWARD,**

Gold and Silver Assayer.  
**Refiner and Sweep Smelter,**  
33 MAIDEN LANE, NEW YORK.  
Smelting and Refining Works,  
28 & 30 Cumberland Street, Brooklyn, N. Y.  
Specialties - Sweepings, Gold, Silver and Platinum.

**J. SCHAWEL & CO., 29 John St., N. Y.**

GOLD & SILVER REFINERS, ASSAYERS & SWEEP SMELTERS.  
STERLING SILVER, 925/1000 FINE IN SHEET AND WIRE.  
Soft Platinum, Sheet and Wire for Manufacturing Jewelers.

**VACHERON & CONSTANTIN,**

GENEVA, SWITZERLAND.



FINEST QUALITY OF WATCH MOVEMENTS, FITTING ALL SIZES OF AMERICAN CASES.

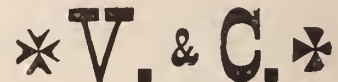

**EDMOND E. ROBERT,**

Agent for the United States and Canada,  
21 & 23 MAIDEN LANE, NEW YORK.

**ALBERT BERGER & CO**

47 MAIDEN LANE, N. Y.  
**Spectacles & Optical Goods,**  
GROUND LENSES A SPECIALTY.

**Headquarters**

FOR ELECTRIC & PORTABLE Watchman's Clocks  
Lowest Prices.  
Latest Improvements,  
Patents 1886-1893.  
Send for Circular.  
**E. O. HAUSBURG,**  
41 Maiden Lane, New York. THE "ALERT."



Price, Complete \$10.00



**A.W.C.CO**

**AMERICAN WATCH CASE CO.,**

MANUFACTURERS OF GOLD CASES.

11 JOHN ST., NEW YORK.

FOR THE RETAIL TRADE.

**WM. BIRMINGHAM & CO.,**

MANUFACTURERS OF  
All Kinds of Leather Spectacle and Eye Glass  
**CASES,**  
728 Arch Street, PHILADELPHIA, PA.

**J. PRINCE,**

Jewelry Auctioneer,  
At liberty from January 1st, 1894. Retail Jewelers only. Address,  
Rooms 9 & 10, 137 BROADWAY  
N. Y. CITY.



AMERICAN RAILWAY SUPPLY CO.,  
24 Park Place, NEW YORK.

FRENCH ENGLISH  
CLOCKS AND HALL CLOCKS AND  
MATERIALS. MATERIALS

**CHAS. JACQUES CLOCK CO.,** 22 CORTLANDT ST., N. Y.

**IT PAYS** TO KEEP IN TOUCH WITH TRADE AFFAIRS.  
THE JEWELERS' CIRCULAR, For 4c. a Week will do it. **Subscribe.**

1869-1894=Twenty-five Years, Oldest, Best, Brightest, Newest, =The Jewelers' Circular.





# THE JEWELERS' CIRCULAR

AND HOROLOGICAL REVIEW.

Copyright by THE JEWELERS' CIRCULAR PUB. CO.

189 Broadway, New York.

Entered at the Post Office in N. Y. as second-class matter.

VOL. XXVIII.

NEW YORK, WEDNESDAY, MARCH 21, 1894.

No. 7.

## WESTERN ART EXPRESSED IN GOLD.

NOTHING has ever aroused the spirit of the various sections of California as has the California Mid-Winter Industrial Exposition. In order that the county which has worked the hardest and produced the most glorious result should have a proper and permanent trophy to mark its excellence, the San Francisco *Examiner* proposes to award a cup of solid gold, whose beauty of design is commensurate with its value. The trophy, which cost \$5,000, was the production of Shreve & Co., San Francisco. The winner of this valuable work in the precious metals is to be determined by vote of the subscribers of the *Examiner*.

The cup is of gold, from the top of the bear that crowns it to the base that rests upon an ebony foundation. Even the rivets and screws that fasten its various parts are of gold. The cup stands 22 inches from the pedestal to the cover, and every inch of its chased and polished surface is ornamented with frets of gold or precious stones. The work is one of the most attractive features of the Exposition. Though it is all of gold it is ablaze with color. Green gold and red gold, yellow and dull and glistening. The base is of dull gold. On the stem in relief are draped flags, the bear banner of California and the stars and stripes with all their colors beautifully brought out in enamel. The body of the cup is of bright polished gold. Above the flag four medallions make a band. On each of these medallions is one of the handsome buildings of the Fair. The Fine Arts building, the Manufactures and Liberal Arts, the Mechanical Arts, and the Agricultural and Horticultural buildings are shown, each in a frame of typical objects.

Around the middle of the cup is a girdle of gold bearing the inscription "California Mid-Winter Industrial Exhibition." The letters are in blue enamel. On each of the four sides a grizzly bear's head is in full relief. From the golden

jaws depend festoons of leaves and fruit. In this girdle various alloys are employed

girdle forms the base upon which the four arms of the cup spring out. These arms are very ornate. In the center of each arm is a rosette of gold-bearing quartz and on top of each one is a cornucopia full of fruit and flowers of parti-colored gold.

On one side is the voting inscription. On the other side is the great seal of the State. The goddess is of dull red gold, on a polished ground. Above her "Eureka" is spelled in letters of emerald, sapphire and diamonds. The stars above are each one large diamond. A wide fluted border forms the mouth of the cup. The cover is a half globe in two colors of gold, surmounted by a golden grizzly bear. The eyes of the bear, like the eyes of the bears' heads on the central girdle, are flashing rubies.

The illustration hardly does full justice to the beauty of the trophy which would be a worthy production in the precious metals from any factory in the country.



THE EXAMINER GOLD PRIZE COUNTY CUP.

### The New Clock in St. Paul's.

THE new clock in St. Paul's Cathedral was made by Smith & Co., of Derby, and is fitted with the double three-leg gravity escapement designed by Lord Grimthorpe, which has proved to be the best choice of the kind for large clocks. The pendulum is 15 feet long and weighs 7 cwt. The old bell, known from the name of the maker as the Phelps bell, is again used for striking, and the old bells for the quarters, but they have been raised higher in the lantern. The Phelps bell weighs 5 tons 4 cwt. The hammer weighs 200 pounds. There are now three faces to the clock, a new one having been inserted to look down Cannon St.

The full diameter of the dials is 17 feet and the central part—that is, the space within the figure ring—is 10 feet. The figures are 2 feet 9 inches long, and the

to tinge the solid gold, and the wreaths of fruit are exquisitely presented. This



# DEITSCH BROS.,

7 EAST 17TH ST., NEW YORK.

## LEATHER GOODS.

EBONY AND SILVER COMBINATIONS.

ORIGINATORS AND MAKERS OF

NOVELTIES IN LEATHER AND STERLING SILVER COMBINATIONS.



\*\*\*\*\*

**CROSS & BEGUELIN,**

17 MAIDEN LANE, NEW YORK,

ALL GRADES OF SWISS AND AMERICAN WATCHES, DIAMONDS, GOLD AND ROLLED PLATE JEWELRY, OPERA AND FIELD GLASSES, TOOLS AND MATERIAL.

SOLE AGENTS FOR THE **Rockford Watch Co.** MATERIAL.

MANUFACTURERS OF THE **Centennial Watches.**

SEND FOR OUR WATCH MATERIAL AND TOOL PRICE LIST FOR 1894.

\*\*\*\*\*

### "THE BEST BUTTON MADE."

THE KREMENTZ

IN GOLD FROM KREMENTZ & CO. AND ALL JOBBERS.



ONE PIECE FROM ALL JOBBERS

IN ROLLED PLATE FROM ALL JOBBERS

**COLLAR BUTTON.**

IS THE ORIGINAL ONE PIECE BUTTON.

IS STILL THE BEST AND STILL UNSURPASSED.

Sold by all wholesale dealers at manufacturer's price.

**A. N. CLARK,**  
PLAINVILLE, CONN.

Manufacturer of the Celebrated **LOOP WATCH KEY.**

The Best for the Price in the World. CROSBY'S JEWELING TOOLS IMPROVED.

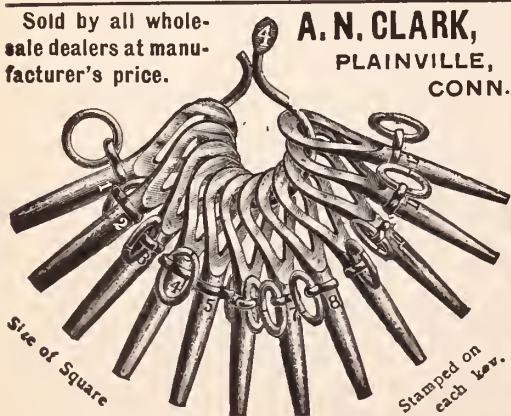

Size of Square

Stamped on each key.



Will quote royalty or price for the manufacturing of articles of real worth.

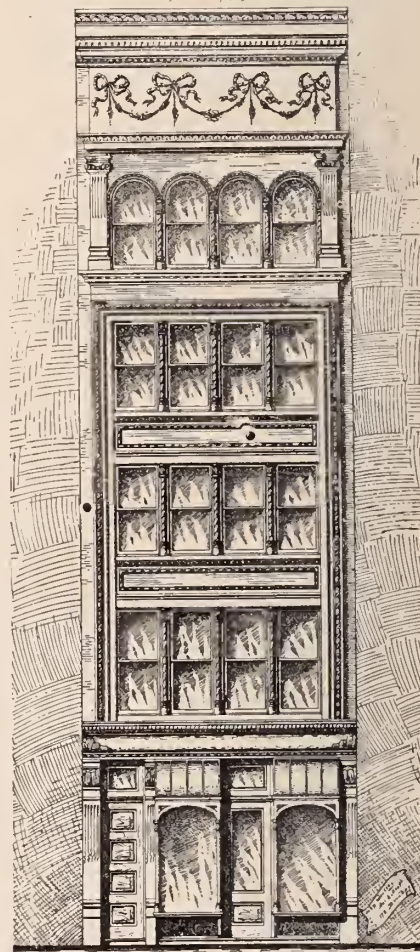

### OFFICES TO LET

BRIGHT AND CHEERFUL,

IN THE

HANDSOME NEW OFFICE BUILDING

**45 MAIDEN LANE,**

with elevator, steam heat, electric light, best of plumbing and all modern conveniences, at rentals from \$350 up. For further particulars, apply to

**E. A. Cruikshank & Co.,**

176 BROADWAY, N. Y.

JACOT & SON  
IMPORTERS AND MANUFACTURERS OF



**BOXES** 298  
BROADWAY.  
NEW YORK.



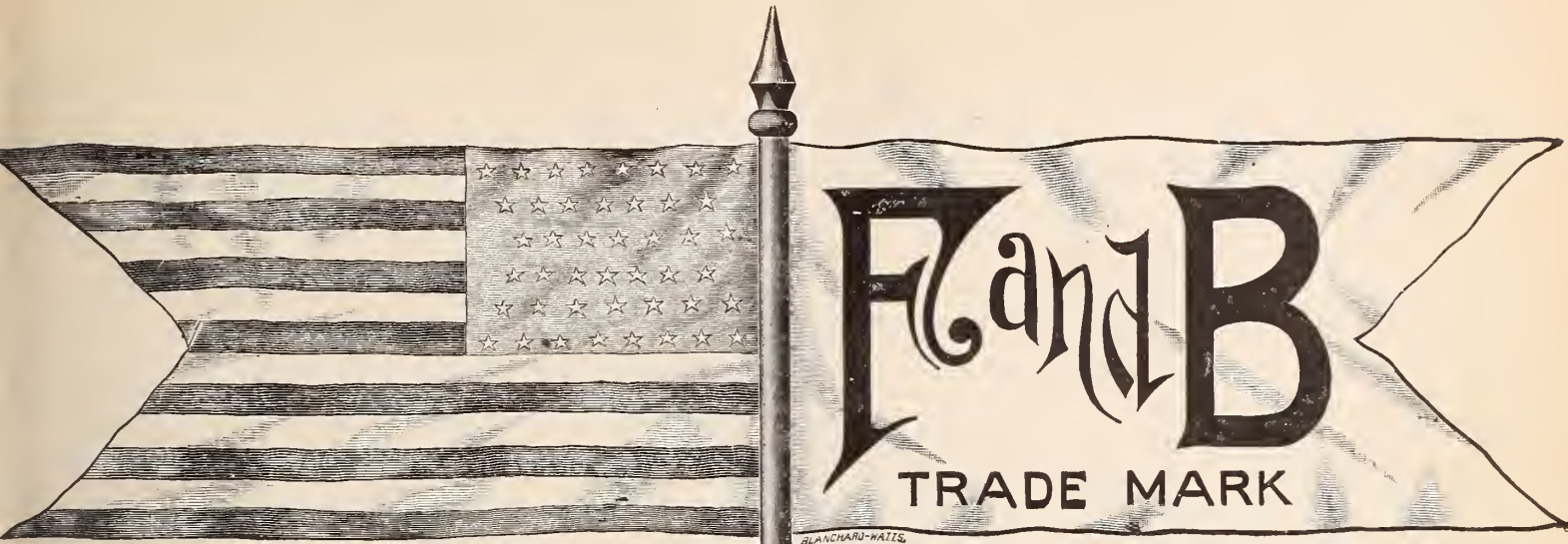

Our American F. & B.  $\frac{1}{10}$  Gold Chains will assay 10 K. 1-10 gold, and are guaranteed for ten years.

Our regular line of Chains is made of heavy gold plate, finely finished, and guaranteed for five years.



**Chains**

Our new line of chains will assay 10 karat 1-10 gold. All gold soldered.  
**American F. & B. 1-10 gold.**

WE RECEIVED  
**4 MEDALS**  
AT THE WORLD'S FAIR.

**Watch Chains for Gentlemen**

These goods are of fine quality, and guaranteed to give satisfaction. Some recently added have sold far beyond expectation. They are made of heavy rolled plate in all sizes and patterns.

**Watch Chains for Ladies**

Our Victoria and Princess chains are neat and pretty. They are made in all bright, Roman and bright, platinum and bright gold, and have one or two charms.

**Mount Hope Button**

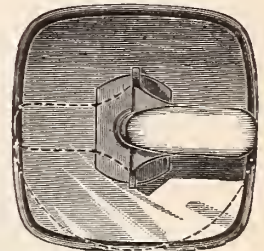

OPEN.

**Mount Hope Button.**



CLOSED.

**Charms**

This line is adapted to ladies' or gentlemen's chains, and includes a number of heart charms in Roman, bright and satin finish, with stones and without.

**Hair Chain Mountings**

In solid gold and rolled plate. We are headquarters and make everything desirable in this line.

**Bracelets**

We make a large stock of curb bracelets in five sizes, besides the graduated links, with padlocks and snaps, in chased and plain polished, Roman, rolled silver plate and sterling silver. Also padlocks with keys and a push snap.

**Pins**

Our large line of lace and cuff pins comprise many desirable patterns in gold fronts engraved and trimmed. Also includes baby pins and scarf pins.

**"Mt. Hope" Buttons**

These are superior to any button in the world. They are easy to put in and easy to take out of the cuff.

**Link Buttons**

This line has increased rapidly with us, and is very low in price, embracing all styles in Roman, chased, engraved and plain, with and without stones, and some in enamel.

**Crosses**

We make four sizes of gold filled in plain, engraved and set with stones, and suitable for our neck chains.

**Sterling Silver and Solid Gold Sword Scarf Pins**

**Glove Buttoners**

We make the Interlocking and one with a twist handle in gold rolled plate and silver rolled plate.

**Earrings**

This line includes many pretty patterns in gold fronts engraved, some with pretty trimmings and a small line of hoop drops.

**Neck Chains**

We make a variety of neck-chains in bright and Roman, with snaps.

**Sterling Silver Bracelets and Padlocks**

**Gold Locket Set with Diamonds**

These lockets are made of 10 karat gold throughout and set with brilliant diamonds. They cannot be surpassed in finish or cheapness of price.

**Gold Locket Engraved**

These lockets are also made of 10 karat gold throughout, with beautiful designs engraved thereon and the price is so low that they cannot fail to be in great demand.

**Gold Front Locket**

This line is very extensive. Many patterns are plain polished, others nicely engraved, with and without stones.

**Rolled-Plate Locket**

This line is almost endless, and consists of nearly every conceivable shape, size and style. Some are set with imitation diamonds, rubies and sapphires.

We have put upon the market a line of Gentlemen's Chains and Ladies' Chain Bracelets made of 1-10 gold stock. Every joint is soldered with gold, and every Chain or Bracelet will assay more than 1-10 gold. They are our AMERICAN F. & B. 1-10 GOLD goods, and are so stamped. Bar, Chain and Swivel are stamped 1-10 gold.

**FOSTER & BAILEY, Providence, R. I.**



# HENRY FERA,

## IMPORTER OF DIAMONDS

AND DIAMOND BORTZ,  
Diamond Cutting and Polishing Establishment.  
10 Maiden Lane, NEW YORK.

## Jules Jürgensen

OF COPENHAGEN.

The reputation these watches have maintained for Fifty Years has never been equalled, being made on strictly scientific principles and no expense spared to give the Best results in mechanism and timekeeping qualities.

SOLE AGENTS,

John E. Hyde's Sons,  
NO. 27 MAIDEN LANE.

hands are of copper, especially shaped to resist wind and snow. The minute hand is 9 feet 6 inches long, and the hour hand 5 feet long. The weights are carried on steel ropes and weigh half a ton each. The clock requires winding every day, and by an ingenious arrangement the clock itself stops the winding when about to strike.—*English Mechanic.*

### Tower Clock for the Government Building in Lowell, Mass.

WASHINGTON, D. C., March 15.—The new Government building at Lowell, Mass., will be when completed a notably handsome structure. It is to be still further embellished by a clock. Proposals are now being invited by the Supervising Architect of the Treasury, for all the labor and materials required, to put in place complete, clock and bell. These bids are to be opened at 2 o'clock, on the afternoon of March 23d.

The clock is to have four dials, 7 feet in diameter, constructed of best quality plate glass  $\frac{3}{8}$  inch thick, ground on both sides, each dial to be in sections, set in cast iron frames with neat moulding on outer edge, the several sections close jointed, set in elastic cement and secured to the jambs, sills and lintels of openings with countersunk head expansion bolts. The hands, numerals and dots are to be finished in best quality gold leaf, and the clock movement is to be designed to strike the hours and half hours. The machinery of the

clock is to have a gravity escapement and compensating pendulum. The machinery of the clock must be provided with an automatic device to turn on and light the gas jets and also to turn them off, the device to be so arranged that it can be set to operate the jets at any desired time. The bell is to weigh 2,000 pounds.

### A Reminiscence of the Otay Watch Co.

SAN JOSE, Cal., March 12.—An important lawsuit has just been ended here, viz., the action of A. L. Canfield vs. G. A. Pennimen, A. C. Pennimen and the San José Watch Co., which was ordered to be disposed by Judge Reynolds. The action was brought in April, 1893, for the recovery of \$1,380 and interest, which was secured by a bill of sale of a number of movements of the Otay Watch Co.

The San José Watch Co. had been formed of the Otay Watch Co., of Otay, and established at Alviso where a town site was laid out, and the embryo city was named New Chicago. Many lots were sold, and the factory was constructed and everything was ready to begin the manufacture of watches, when the depression came and crippled the enterprise. A. L. Canfield was one of the creditors of the San José Watch Co., and sought by suit, to hold the members of the company for his debt. The suit was dismissed at the cost of the plaintiff.

**Three Great Successes.**

Our Industrial School of Optics Practical  
Our Swell Gold Construction Progressive  
Our Prescription Department Punctual

**ASSURED SUCCESS TO YOU**

If you take the Practical course in refraction, sell The Swell End Eyewire Gold Spectacles and Eye Glasses, and send your Prescription work to our special department which you will find accurate and punctual.

Avoid delay and errors by keeping in mind the old reliable

**Spencer Optical M'f'g Co.**

15 MAIDEN LANE, NEW YORK.

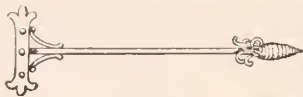

## BIG RETURNS MADE FOR OLD GOLD AND SILVER.

Check Forwarded 24 Hours After Receipt of Consignment.

### J. RATHBONE,

GOLD AND SILVER REFINER, ASSAYER AND SWEEPSMELTER,

Nos. 1 to 9 Matthewson St., Cor. Cove, Providence, R. I.

# Paul Jeanne,

EIGHTEENTH STREET and 4<sup>TH</sup> AVE., N. Y.  
(Bradley Building.)

MANUFACTURER OF

≡ FINE ⊗ DIAMOND ⊗ JEWELRY. ≡

## VICTOR. ⊗ ⊗

SIMPLEST FEED. ALWAYS THE SAME.  
GUARANTEED FOR ONE YEAR.

### THE VICTOR FOUNTAIN PEN

(Pat. Feb. 4, 1890.)

THE BOSTON PEN CO.,

N. C. Whitaker & Co., Proprietors.

363 Washington Street, Boston, Mass.,

Manufacturers of finest quality

TORTOISE : SHELL : AND : HORN : GOODS

in every variety. Also Aluminum Hair Pins.

Send for illustrated Pen Price List No. 1.

## LOOKING FOR THE COLUMBIAS?

AN ADJUSTABLE EYE-CLASS THAT  
CAN'T BREAK NOR GET OUT  
OF ORDER.

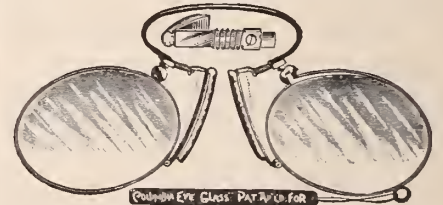

DON'T BUY UNTIL YOU SEE ONE OF OUR  
COLUMBIAS.

### E. KIRSTEIN'S SONS CO.,

SOLE MANUFACTURERS,

ROCHESTER, NEW YORK.

Send us your Rx. work, when you want same at once.



We have in Stock  
 ... THE ...  
 Largest Line of  
**RICH CUT** \*  
 ... AND ...

THE

*Point*

MFG. COMPANY.

MAKERS OF "SUPERIOR"  
 GOLD AND SILVER PLATE  
 In Hollow and "1880" Flat Ware.

FACTORIES:

New Bedford,  
 Mass.

SALESROOMS:

NEW YORK, = 20 Maiden Lane.  
 CHICAGO, = 224 Wabash Ave.  
 SAN FRANCISCO, 220 Sutter St.

Decorated Art Glassware  
 IN AMERICA.



No. 671. PICKLE OR OLIVE DISH.

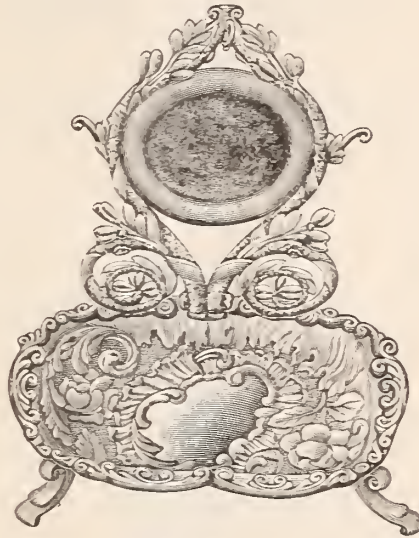

No. 940. EMBOSSED PIN TRAY AND WATCH STAND COMBINED.

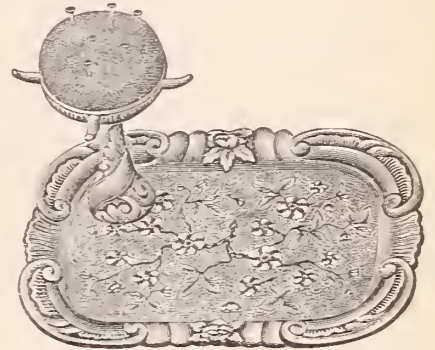

No. 939. TRINKET TRAY, RING STAND AND PIN CUSHION. (PATENT APPLIED FOR.)

**A. J. LOGAN,**  
 MANUFACTURER OF  
 WATCH TOOLS, HAIR SPRINGS AND  
**WATCH MATERIALS.**  
 < New Catalogue just issued, Sent on Application. >  
 WALTHAM, MASS.

If Your Sales  
 Are Not Satisfactory

ADDRESS

**DE B. O. SCOTT,**  
 20 Murray Street, New York.  
 AUCTIONEER.

Specialties: Watches, Clocks, Bric-a-Brac, &c.  
 Write for particulars and references.

AWARD AT WORLD'S FAIR, CHICAGO, 1893.  
 The Providence Shell Works.  
**W. K. Potter,**  
 346 Westminister St., Providence, R. I.



Tortoise Shell Goods, Combs, Hair Ornaments, Jewelry, Etc.  
 Shell Work made to order on contract. Repairing for the trade in all its branches.

We sell to the legitimate Jewelry and Stationery trade only.



CHOICE PAPERS

MAKERS OF

**FINE STATIONERY**

For Correspondence, Wedding and Business Use, handsomely boxed, specially suited to the Jewelry Trade.

18 MURRAY STREET, NEW YORK.



# R. WALLACE & SONS MFG. CO.

## SILVERSMITHS

Trade Mark.

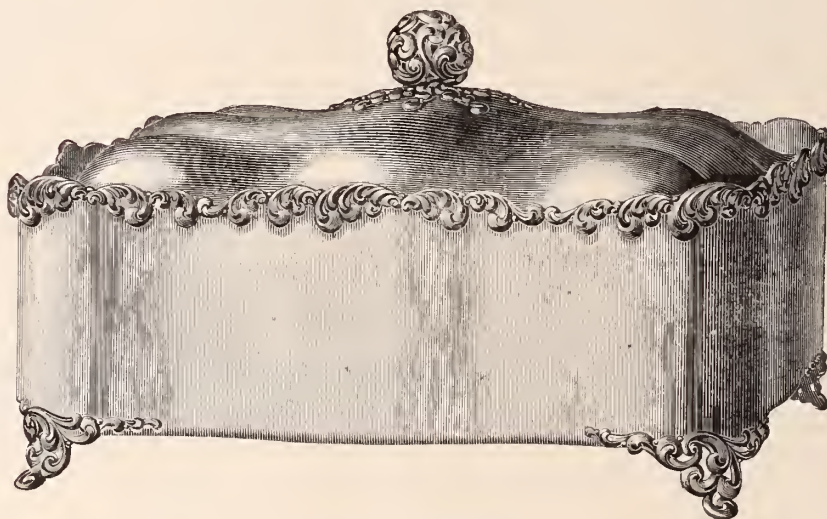

WAVERLEY SARDINE BOX.

Manufactories and  
Main Office,

WALLINGFORD, - - CONN.

BRANCHES :

NEW YORK  
3 PARK PLACE.

SAN FRANCISCO,  
120 SUTTER STREET.

CHICAGO  
86 WABASH AVENUE.



**Among the South African Diamond Mines.**

THE DIAMOND SYNDICATE PURCHASE ALL THE ROUGH ON HAND UP TO FEB. 1—THE INFLUENCE OF THIS SYNDICATE—SOUTH AFRICAN OPINION ON THE INCREASE OF AMERICAN DUTIES ON DIAMONDS.

KIMBERLEY, Feb. 12.—As I have mentioned in previous communications the Diamond Syndicate of Kimberley relieved the De Beers Co. of their enormous stock of rough goods at a period when the market in London, on the Continent and in America, was in a deplorable state of collapse. Ready capital on that occasion had the effect of assisting the company in financial arrangements of an important nature, and as was explained by Mr. Rhodes, when he presided at the annual meeting last month, shareholders gained a distinct advantage in getting the products of their mining disposed of by directors who are at the same time connected with the diamond merchant trade.

I have now to report that the syndicate has again purchased the rough goods on hand up to Feb. 1, thereby relieving the De Beers Co. from material responsibility. The members of the syndicate are Barnato Bros., Wernher, Beit & Co., Mosenthal; Dunkelsbuhler, and Joseph Bros. All these diamond firms are powerful wielders of the fate, not only of the future of the industry itself, but of the merchants in London, in Amsterdam and elsewhere in Europe, as well as in America. The point is this and it is a supreme point of influence, that they can buy in the market of production, quite independent of political complication in America or financial difficulties in London or Amsterdam. But when they do not buy, it may be taken for granted that they are panic-stricken.

Special cablegrams from day to day, of course, show what is the condition of affairs in America and in London. Everyone here seems to expect that the check given to the prosperity of the United States is purely temporary, and that when the sun shines again on the heads of our cousins, and the dollar is once more omnipotent, the diamond of South Africa will emerge, dazzling with the dazzle of costliness, out of the recent crash of banks, and other unstable institutions. Therefore, the hasty legislation by which an absurdly high duty is levied on our product by the American lower house, is all the more to be condemned. The simple fact that the local syndicate, whose members have again invested to the extent of very many thousands in the Griqualand West production up to the latest date, proves the solidity and permanency of an enterprise only equaled by gold development.

One trusts that by this time the pregnant words of Mr. Rhodes, chairman of De Beers, as to the relationship of America with the Cape diamond production, have reached both New York and Washington. The luxury loving ladies of the great American centers may thirst after diamonds with the thirst of the Sahara; but the production is

the possession of the mines of Griqualand West, and no customs duty, especially on rough goods, even when imposed at the present time can appease that thirst, unless reasonable fiscal terms are agreed to, for the diamond production of the world is in the hands of Kimberley. ST. GEORGE.

THE JEWELERS' CIRCULAR celebrated its silver anniversary in February with an extra large double number. They reproduce a page of their No. 1, and I think, Mr. Editor, that the strides that journal has made are unparalleled in trade journalism. When we read their first article on diamonds we cannot help feeling very old if that was written in our time, and when we read the journal to-day we almost feel we are living in the future.—*Watchmaker, Jeweler and Silversmith, London.*

**WM. SCHWARZWAELDER & CO.,**

Fulton St., cor. Pearl, - NEW YORK

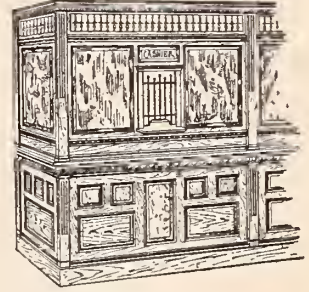

MANUFACTURERS OF

**DESKS, CHAIRS, Etc.**

Jewelers' Cases and Counters. Office Partitions, Rails, Etc.

Special Designs, Plans, Prices, etc. upon application.

**DIAMOND EXCHANGE BUILDING.**

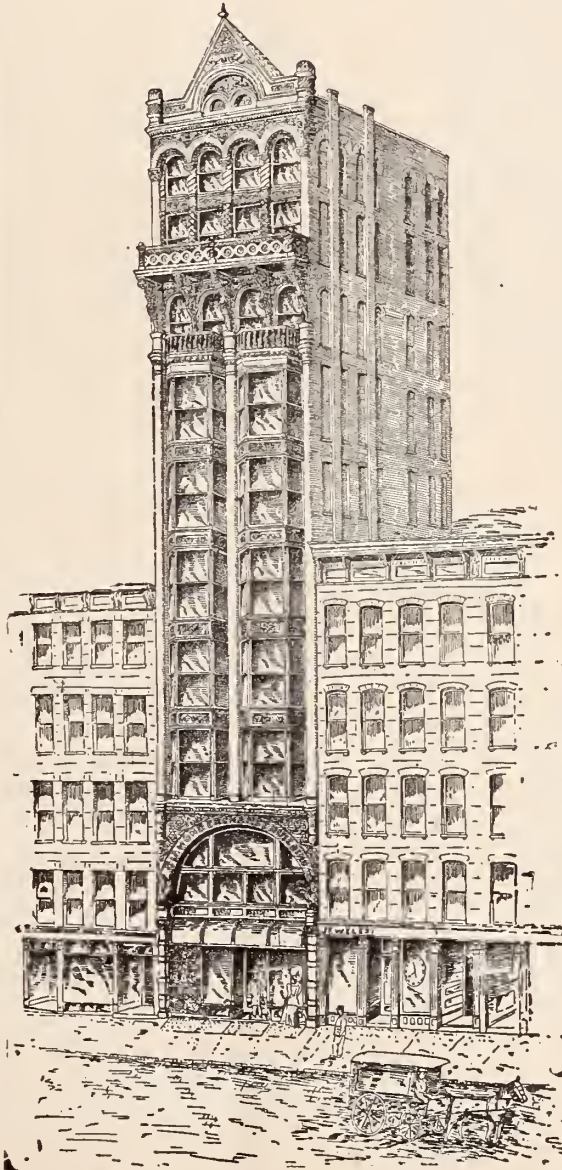

**Go Let**

In the new fire proof, ten story

Diamond Exchange Building,

14 Maiden Lane.

**OFFICES**

of most modern construction, with abundance of light and air, rapid elevator, mail chute, steam heat, gas and electric light, exposed sanitary plumbing, oak cabinet trim, unique plate glass partition and quartered oak floors. at rentals from

**\$900.00**

Per Annum up.

Specially adapted for the Diamond and Jewelry Trade. Possession on or before May 1st, next.

For further particulars apply to

**E. A. Cruikshank & Co.,**

176 Broadway, N. Y.

**THE ELEVATOR IS NOW RUNNING.**



# EBONY AND SILVER TOILET ARTICLES.

A COMPLETE NEW LINE (25 VARIETIES) OF PHOTO FRAMES IN STERLING SILVER-MOUNTED EBONY, ALSO SOLID SILVER.



AS this combination is to be very fashionable this season, we have produced the most elaborate line on the market in Ladies' and Gentlemen's Toilet and Manicure Articles. These goods are mounted with pierced Sterling Silver, and decorated by the most artistic hand engraving

A full line of these goods will make a beautiful window display.



## MADE IN

HAIR BRUSHES.  
 MILITARY BRUSHES.  
 CLOTH BRUSHES.  
 HAT BRUSHES.  
 BONNET BRUSHES.  
 GENTLEMEN'S COMBS.  
 LADIES COMBS.  
 ROUND AND OVAL MIRRORS.  
 WHISK BROOMS.  
 SHOE AND BUTTON HOOKS.  
 NAIL POLISHERS.  
 POWDER AND PUFF BOXES.  
 NAIL POWDER BOXES.  
 SHOE HORNS.  
 NAPKIN RINGS.  
 PAPER CUTTERS.  
 HAND BLOTTERS.  
 NAIL FILES.  
 PIN TRAYS.  
 CORN KNIVES, etc.

A complete new line of Sterling Mounted Ebonized Briar Wood Pipes.

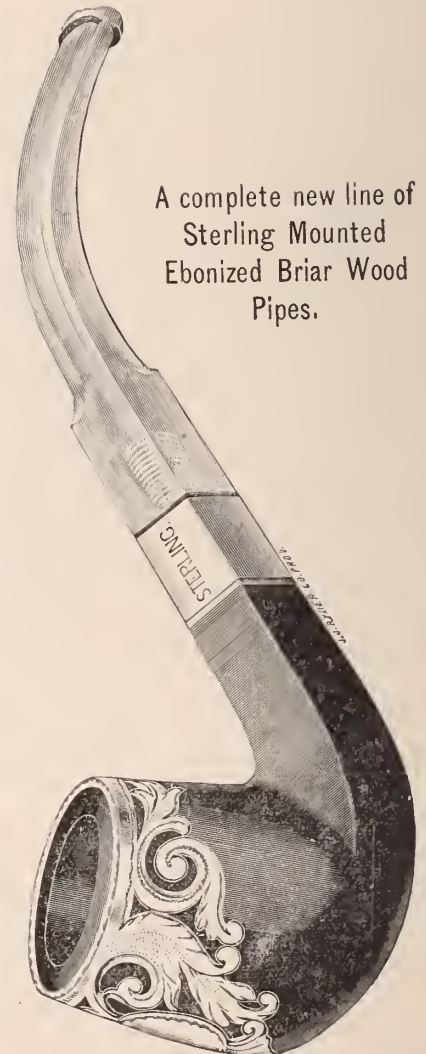

THESE PIPES ARE GENUINE BRIAR, NATURAL OR EBONIZED.

# J. N. PROVENZANO,

GOLD AND SILVERSMITH,

No. 39 UNION SQUARE,

NEW YORK CITY.



**Labor Statistics Relating to the Jewelry and Kindred Trades.**

WASHINGTON, D. C., March 17.—Hon. Carroll D. Wright, Commissioner of Labor, in charge of the completion of the Eleventh Census, has transmitted to the Secretary of the Interior a report which presents preliminary totals for all classes of mechanical and manufacturing industries in the United States as prepared by the Division of Manufactures. The following are the statistics relating to the jewelry and kindred trades:

**CLOCKS.**

Number of establishments reporting	27
Aggregate capital represented	\$5,727,202
Total value of plant	1,836,508
Value of land	240,562
Value of buildings	621,054
Value of machinery, tools and implements	974,892
Live assets	3,890,694
Miscellaneous expenses	272,984
Average number of employes	3,585
Total wages	\$1,935,525
Officers, firm members, and clerks above 16 years (males)	86
Wages for same	\$123,908
Officers, firm members and clerks above 15 years (females)	8
Wages for same	\$3,592
Operatives, skilled and unskilled, above 16 years (males)	1,809
Wages for same	\$1,048,449
Operatives, skilled and unskilled, above 15 years (females)	322
Wages for same	\$107,189
Children operatives	25
Wages for same	\$4,567
Pieceworkers above 16 years (males)	1,133
Wages for same	\$586,723
Pieceworkers above 15 years (females)	188
Wages for same	\$57,685
Children pieceworkers	14
Wages for same	\$3,412
Cost of materials used	1,457,773
Value of products, including receipts from custom work and repairing	4,228,846

**CLOCK CASES AND MATERIALS.**

Number of establishments reporting	4
Aggregate capital represented	\$43,863
Total value of plant	24,399
Value of land	8,000
Value of buildings	3,133
Value of machinery, tools and implements	13,286
Live assets	19,464
Miscellaneous expenses	2,308
Average number of employes	32
Total wages	\$20,688
Officers, firm members and clerks, above 16 years (male)	3
Wages for same	\$3,250
Operatives, skilled and unskilled, above 16 years (males)	29
Wages for same	\$17,438
Cost of materials used	11,724
Value of products, including receipts from custom work and repairing	44,038

**JEWELRY.**

Number of establishments reporting	783
Aggregate capital represented	\$22,246,508
Total value of plants	4,141,958
Value of land	173,200
Value of buildings	405,661
Value of machinery, tools and implements	3,563,097
Live assets	18,104,550
Miscellaneous expenses	1,493,545
Average number of employes	15,761
Total wages	\$10,270,393
Officers, firm members, and clerks above 16 years (males)	1,712
Wages for same	\$2,158,469
Officers, firm members, and clerks above 15 years (females)	169

Wages for same	\$73,257
Operatives, skilled and unskilled, above 16 years (males)	9,760
Wages for same	\$6,286,793
Operatives, skilled and unskilled, above 15 years (females)	2,598
Wages for same	\$824,420
Children operatives	215
Wages for same	\$36,665
Pieceworkers above 16 years (males)	936
Wages for same	\$767,663
Pieceworkers above 15 years (females)	370
Wages for same	\$122,825
Children pieceworkers	1
Wages for same	\$21
Cost of materials used	\$16,110,219
Value of products, including receipts from custom work and repairing	\$34,761,458

**JEWELRY AND INSTRUMENT CASES.**

Number of establishments reporting	76
Aggregate capital represented	\$634,900
Total value of plants	141,196
Value of land	1,700
Value of buildings	16,700
Value of machinery, tools and implements	122,796
Live assets	493,704
Miscellaneous expenses	70,679
Average number of employes	1,038
Total wages	\$587,574
Officers, firm members and clerks above 16 years (males)	127
Wages for same	\$140,231
Officers, firm members and clerks above 15 years (females)	1
Wages for same	\$416
Operatives, skilled and unskilled, above 16 years (males)	597
Wages for same	\$367,225
Operatives, skilled and unskilled, above 15 years (females)	260
Wages for same	\$60,068
Children operatives	17
Wages for same	\$2,824
Pieceworkers above 16 years (males)	23
Wages for same	\$14,780
Pieceworkers over 15 years (females)	12
Wages for same	\$1,796
Children pieceworkers	1
Wages for same	\$234
Cost of materials used	\$483,441
Value of products, including receipts from custom work and repairing	\$1,454,053

**SILVERWARE.**

Number of establishments reporting	30
Aggregate capital represented	\$5,317,641
Total value of plants	1,763,676
Value of land	215,500
Value of buildings	\$380,500
Value of machinery, tools and implements	1,103,676
Live assets	3,551,274
Miscellaneous expenses	638,891
Average number of employes	2,306
Total wages	\$1,618,429
Officers, firm members and clerks above 16 years (males)	40
Officers, firm members and clerks above 15 years (females)	21
Wages of males	\$214,144
Wages of females	9,312
Operatives, skilled and unskilled, above 16 years (males)	1,941
Wages for same	\$1,302,637
Operatives, skilled and unskilled, above 15 years (females)	130
Wages for same	\$39,887
Children operatives	12
Wages for same	\$2,119
Piece workers above 16 years (males)	62
Wages for same	\$50,330
Cost of materials used	2,129,344
Value of products, including receipts from custom work and repairing	5,813,737

**SILVERSMITHING.**

Number of establishments reporting	24
Aggregate capital represented	\$410,773
Total value of plants	79,275
Value of land	550
Value of buildings	200

Value of machinery, tools and implements	78,525
Live assets	331,498
Miscellaneous expenses	20,755
Average number of employes	314
Total wages	\$253,652
Officers, firm members and clerks above 16 years (males)	34
Wages for same	\$56,498
Officers, firm members and clerks above 15 years (females)	6
Wages for same	\$3,376
Operatives, skilled and unskilled, above 16 years (males)	257
Wages for same	\$187,260
Operatives, skilled and unskilled, above 15 years	13
Wages for same	\$5,856
Children operatives	4
Wages for same	\$612
Cost of materials used	204,237
Value of products, including receipts from custom work and repairing	621,567

**WATCHES.**

Number of establishments reporting	19
Aggregate capital represented	\$10,106,114
Total value of plants	4,941,217
Value of land	679,971
Value of buildings	1,554,510
Value of machinery, tools and implements	2,706,736
Live assets	5,104,897
Miscellaneous expenses	733,404
Average number of employes	6,675
Total wages	\$3,688,927
Officers, firm members and clerks above 16 years (males)	70
Wages for same	\$95,555
Officers, firm members, and clerks above 15 years (females)	10
Wages for same	\$4,564
Operatives, skilled and unskilled, above 16 years (males)	1,609
Wages for same	\$1,102,824
Operatives, skilled and unskilled, above 15 years (females)	847
Wages for same	\$333,405
Children operatives	20
Wages for same	\$5,400
Pieceworkers above 16 years (males)	2,326
Wages for same	\$1,472,244
Pieceworkers above 15 years (female)	1,793
Wages for same	\$673,933
Cost of materials used	995,740
Value of products, including receipts from custom work and repairing	6,051,066

**WATCH CASES.**

Number of establishments reporting	45
Aggregate capital represented	\$4,727,100
Total value of plants	1,495,991
Value of land	127,850
Value of buildings	404,500
Value of machinery, tools and implements	963,641
Live assets	3,231,109
Miscellaneous expenses	443,175
Average number of employes	3,869
Total wages	\$2,116,286
Officers, firm members and clerks above 16 years (males)	173
Wages for same	\$212,763
Officers, firm members and clerks above 15 years (females)	17
Wages for same	\$6,936
Operatives, skilled and unskilled, above 16 years (males)	2,224
Wages for same	\$1,347,071
Operatives, skilled and unskilled, above 15 years (females)	508
Wages for same	\$150,952
Children operatives	23
Wages for same	\$3,645
Pieceworkers above 16 years (males)	720
Wages for same	\$324,590
Pieceworkers above 15 years (females)	202
Wages for same	\$41,848
Children pieceworkers	2
Wages for same	\$481
Cost of materials used	\$5,022,455
Value of products, including receipts from custom work and repairing	\$8,618,479



WATCH AND CLOCK MATERIALS.

Number of establishments reporting.....	32
Aggregate capital represented.....	\$661,784
Total value of plants.....	361,250
Value of land.....	55,500
Value of buildings.....	56,100
Value of machinery, tools and implements.....	249,650
Live assets.....	300,534
Miscellaneous expenses.....	29,099
Average number of employes.....	563
Total wages.....	\$292,497
Officers, firm members and clerks above 16 years (males).....	44
Wages for same.....	\$51,138
Officers, firm members and clerks above 15 years (females).....	1
Wages for same.....	\$375
Operatives, skilled and unskilled, above 16 years (males).....	371
Wages for same.....	\$197,902
Operatives, skilled and unskilled, above 15 years (females).....	111
Wages for same.....	\$29,834
Children operatives.....	11
Wages for same.....	\$2,098
Pieceworkers above 16 years (males).....	17
Wages for same.....	\$ 9,750
Pieceworkers above 15 years (females).....	5
Wages for same.....	\$1,000
Children pieceworkers.....	3
Wages for same.....	\$400
Cost of materials used.....	314,674
Value of products, including receipts from custom work and repairing.....	787,310

WATCH, CLOCK AND JEWELRY REPAIRING.

Number of establishments reporting.....	4,502
Aggregate capital represented.....	\$6,057,125
Total value of plants.....	3,251,016
Value of land.....	877,854
Value of buildings.....	818,144
Value of machinery, tools and implements.....	1,555,048
Live assets.....	2,806,079
Miscellaneous expenses.....	1,047,525
Average number of employes.....	8,647
Total wages.....	\$5,516,595
Officers, firm members and clerks above 16 years (males).....	3,803
Wages for same.....	\$2,645,708
Officers, firm members and clerks above 15 years (females).....	25
Wages for same.....	\$9,767
Operatives, skilled and unskilled, above 16 years (males).....	4,421
Wages for same.....	\$2,731,185
Operatives, skilled and unskilled, above 15 years (females).....	69
Wages for same.....	\$21,780
Children operatives.....	116
Wages for same.....	\$18,212
Pieceworkers above 16 years (males).....	211
Wages for same.....	\$88,383
Pieceworkers above 15 years (females).....	2
Wages for same.....	\$1,560
Cost of materials used.....	\$2,225,888
Value of products, including receipts from custom work and repairing.....	10,704,477

PLATED AND BRITANNIA WARE.

Number of establishments reporting.....	68
Aggregate capital represented.....	\$13,150,990
Total value of plants.....	3,922,351
Value of land.....	304,382
Value of buildings.....	999,259
Value of machinery, tools and implements.....	2,618,710
Live assets.....	9,228,639
Miscellaneous expenses.....	1,276,431
Average number of employes.....	6,919
Total wages.....	\$3,775,305
Officers, firm members, and clerks above 16 years (males).....	278
Wages for same.....	\$408,892
Officers, firm members, and clerks above 15 years (females).....	24
Wages for same.....	\$11,153
Operatives, skilled and unskilled, above 16 years (males).....	4,857

Wages for same.....	\$2,700,124
Operatives, skilled and unskilled, above 15 years (females).....	709
Wages for same.....	\$200,457
Children operatives.....	147
Wages for same.....	\$25,733
Pieceworkers above 16 years (males).....	623
Wages for same.....	\$346,509
Pieceworkers above 15 years (females).....	265
Wages for same.....	\$80,340
Children pieceworkers.....	16
Wages for same.....	\$2,097
Cost of materials used.....	4,647,890
Value of products, including receipts from custom work and repairing.....	11,502,966

LAPIDARY WORK.

Number of establishments reporting.....	29
Aggregate capital represented.....	\$100,635
Total value of plants.....	26,435
Value of machinery, tools and implements.....	26,435
Live assets.....	74,200
Miscellaneous expenses.....	13,294
Average number of employes.....	129
Total wages.....	\$99,486
Officers, firm members and clerks above 16 years (males).....	36
Wages for same.....	\$39,344
Officers, firm members and clerks above 15 years (females).....	1
Wages for same.....	\$1,500
Operatives, skilled and unskilled, above 16 years (males).....	82
Wages for same.....	\$54,512
Children operatives.....	5
Wages for same.....	\$780
Pieceworkers above 16 years (males).....	5
Wages for same.....	\$3,350
Cost of materials used.....	124,852
Value of products, including receipts from custom work and repairing.....	315,604

GOLD PENS.

Number of establishments reporting.....	18
Aggregate capital represented.....	\$473,964
Total value of plants.....	149,120
Value of land.....	12,000
Value of buildings.....	8,000
Value of machinery, tools and implements.....	129,120
Live assets.....	324,844
Miscellaneous expenses.....	82,753
Average number of employes.....	363
Total wages.....	\$260,669
Officers, firm members and clerks above 16 years (males).....	56
Wages for same.....	\$72,900
Officers, firm members and clerks above 15 years (females).....	6
Wages for same.....	\$2,224
Operatives, skilled and unskilled, above 16 years (males).....	239
Wages for same.....	\$151,325
Operatives, skilled and unskilled, above 15 years (females).....	23
Wages for same.....	\$6,952
Children operatives.....	1
Wages for same.....	\$104
Pieceworkers above 16 years (males).....	38
Wages for same.....	\$27,104
Cost of materials used.....	235,628
Value of products, including receipts from custom work and repairing.....	\$718,070

OPTICAL GOODS.

Number of establishments reporting.....	191
Aggregate capital representing.....	\$2,608,176
Total value of plants.....	906,727
Value of land.....	64,381
Value of buildings.....	144,495
Value of machinery, tools and implements.....	73,300
Live assets.....	1,701,449
Miscellaneous expenses.....	228,028
Average number of employes.....	2,844
Total wages.....	\$1,300,452
Officers, firm members and clerks above 16 years (males).....	302
Wages for same.....	\$275,494
Officers, firm members and clerks above 15 years (females).....	

Wages for same.....	\$14,584
Operatives, skilled and unskilled, above 16 years (males).....	1,599
Wages for same.....	\$759,173
Operatives, skilled and unskilled, above 15 years (females).....	389
Wages for same.....	\$76,928
Children operatives.....	103
Wages for same.....	\$15,968
Pieceworkers above 16 years (males).....	269
Wages for same.....	\$118,035
Pieceworkers above 15 years (females).....	118
Wages for same.....	\$34,583
Children pieceworkers.....	29
Wages for same.....	\$5,687
Cost of materials used.....	1,324,305
Value of products, including receipts from custom work and repairing.....	3,505,973

ENAMELING.

Number of establishments reporting.....	27
Aggregate capital represented.....	\$71,917
Total value of plants.....	33,387
Value of land.....	5,000
Value of buildings.....	3,800
Value of machinery, tools and implements.....	24,587
Live assets.....	38,530
Miscellaneous expenses.....	15,751
Average number of employes.....	187
Total wages.....	\$104,672
Officers, firm members and clerks above 16 years (males).....	33
Wages for same.....	\$30,086
Operatives, skilled and unskilled, above 16 years (males).....	129
Wages for same.....	\$67,126
Operatives, skilled and unskilled, above 15 years (females).....	23
Wages for same.....	\$7,044
Children operatives.....	2
Wages for same.....	\$416
Cost of materials used.....	52,999
Value of products, including receipts from custom work and repairing.....	181,942

ENAMELING GOODS.

Number of establishments reporting.....	19
Aggregate capital represented.....	\$350,798
Total value of plants.....	143,472
Value of land.....	6,000
Value of buildings.....	9,000
Value of machinery, tools and implements.....	128,472
Live assets.....	2 7,326
Miscellaneous expenses.....	23,856
Average number of employes.....	391
Total wages.....	\$104,672
Officers, firm members and clerks above 16 years (males).....	37
Wages for same.....	\$42,378
Operatives, skilled and unskilled above 16 years (males).....	232
Wages for same.....	\$116,294
Operatives, skilled and unskilled above 15 years (females).....	92
Wages for same.....	\$27,252
Children operatives.....	20
Wages for same.....	\$3,000
Pieceworkers above 16 years (males).....	10
Wages for same.....	\$3,000
Cost of materials used.....	\$118,659
Value of products, including receipts from custom work and repairing.....	\$444,942

Among the silver plate manufacturing firms who can boast of an existence of over a quarter of a century, is the Aurora Silver Plate Mfg. Co., Aurora, Ill. This company are now celebrating their silver anniversary, having started in 1869. The growth since that time is well-known to the jewelry trade, with whom the company's product has acquired a lasting popularity. Through the efficient management of their treasurer, F. B. Rice, the company have pushed to the front until the Aurora flat and hollow ware has gained the position which it to-day holds.



### Nebraska Jewelers Form a State Organization.

LINCOLN, Neb., March 14.—Nearly 100 retail jewelers were present at Masonic Hall this afternoon to participate in the organization of the State retail jewelers' association. Many of the prominent jewelers of the State were present including Julius Meyer, John Baumer, S. Jonasen and J. Bergmen, of Omaha. The meeting was called to order shortly after 2 o'clock, and Fritz Hoefler, of Aurora, was made temporary chairman, and F. A. Harmis, of York, secretary. Richard O'Neill, of Lincoln, then made a brief address welcoming the jewelers to Lincoln, to which John Baumer made a neat and fitting response.

A resolution was adopted admitting all parties engaged in the retail business exclusively to the convention after which the following committee was appointed to prepare and print resolutions for the proposed new organization: C. L. Hayes, of Norfolk; John Baumer, of Omaha; E. A. Poley, of Seward; M. M. Huck, of Schuyler, and George Arkwright, of Beatrice. A resolution was also adopted inviting Newton Dexter to address the convention.

### Exports of Watches from Geneva During 1893.

WASHINGTON, D. C., March 17.—In the Consular Reports for March, 1894. Irving B. Richman, consul-general to Switzerland writes: "In the district of Geneva there has been during 1893, as compared with 1892 (which was an excellent business year), a heavy decrease in exports, especially of music boxes and watches. The amount of this decrease is 420,207.73 francs (\$81,098.75). The causes have been (1) tariff uncertainties, and (2) the monetary crisis in the United States. A better feeling is now beginning to prevail. The agents of Geneva houses in America write more encouragingly to their principals. They predict a spirited and substantial revival of trade as soon as Congress acts on the tariff. As respects fine and cheap enamel jewelry, there already is a marked revival. A leading Geneva manufacturer in this line is receiving new and large orders, especially from Chicago. He can not employ men enough to get out the work. An invoice of cheap watches during the present week (the first for many months) is an excellent sign."

### Prospects of American Trade in Mexico.

WASHINGTON, D. C., March 17.—Under date of Jan. 5, 1894, Consul-General Crittenden, of Mexico City, writes as follows in relation to American trade in general in Mexico:

"All things are tending toward a stronger government and a more prosperous country. The United States, England and Germany are now strong contestants for the trade of Mexico. The United States is making the greatest gain and would secure even more Mexican trade if our merchants would give closer attention to its wants, habits of trade, and methods of purchase. The merchants

of the United States should have certain classes of goods manufactured for and adapted to this country and should educate a class of commercial men for this special trade. Whatever Mexican trade may have been in the past there are cogent reasons for believing it will be much larger in the future.

"Facilities for monetary exchange are not very extensive. Banks charge more for American exchange than for any other, and offer none other for sale than New York. Spanish exchange is cheapest, and German next cheapest. An American banking institution having correspondents in every important city in the United States would be desirable, and would do well in this city and perhaps in other cities of this Republic."

### Death of Thomas S. Negus.

Thomas S. Negus well-known, among the makers of chronometers and fine watches, died at his home, 15 Sussex Place, Jersey City, N. J., Saturday from heart failure resulting from heart and kidney trouble. Mr. Negus was senior partner in the firm of T. S. & J. D. Negus, dealers in chronometers, and natural instruments, 140 Water St., New York.

Deceased was born in New York in 1828 and as a boy learned the trade of chronometer maker. When 20 years old with his brother he founded the firm of T. S. & J. D. Negus which soon became one of the leading nautical instrument firms of the country. J. D. Negus died a few years ago, and was succeeded by his son, J. S. Negus, the firm name however remaining unchanged. Mr. Negus had been an invalid for the past 10 to 12 years, and of late had not been actually engaged in business. Governor Parker, of New Jersey, 19 years ago, named Mr. Negus Pilot Commissioner, and for the

last 15 years he was president of the New Jersey Board of Pilot Commissioners. He was a member of Holland Lodge of Free Masons in this city, and for 14 years belonged to the Seventh Regiment.

The funeral services were held yesterday at the late residence of the deceased. The interment took place at Greenwood Cemetery. The deceased leaves three grown children. His nephew and partner, J. S. Negus, continues the business.

### Meeting of the Creditors of W. S. Taylor & Son.

A meeting of the creditors of W. S. Taylor & Son, Utica, N. Y., was held at the rooms of the New York Jewelers' Board of Trade, Saturday afternoon. The seven creditors present who represented about \$4,000 of the merchandise indebtedness, had been previously given a statement of the firm's liabilities and assets. The liabilities amounted to about \$24,000, of which \$11,500 was in judgments confessed for money loaned and the rest for merchandise. The actual assets on a hard pan basis were given as about \$17,850, the nominal value of these being about three times that sum.

The firm gave as reason for their confession of judgment to their creditors who had loaned them money from time to time, that owing to the falling off in business and the fact that some creditors were pushing them, the action was necessary in order to protect their creditors. W. S. Taylor, who was present at the meeting, made an offer of settlement at 25 per cent. cash which was refused. The creditors suggested that he offer 50 per cent., but this he said, he could not do. Since the meeting Mr. Taylor has submitted an offer of 33 per cent., of which 25 is to be cash, and the balance in notes of eight months dating from April 1st, unsecured.



# Removal! . . . .

## J. W. RICHARDSON & Co.

MANUFACTURERS OF

# Gold Emblems

Have removed to

No. 200 BROADWAY,  
NEW YORK.





# Sterling Silver Belts

We are the originators of this style of belt and we propose to hold the trade on them.

 Price \$1.25 complete, Moire Antique or plain ribbon.

 Price \$1.35 complete, Moire Antique or plain ribbon.

 Price \$1.75 complete, Moire Antique or plain ribbon.

 Price \$1.75 complete, Moire Antique or plain ribbon.

WE ARE PLEASED TO ANNOUNCE THAT NOTWITHSTANDING THE ENORMOUS DEMAND FOR THE MOIRE ANTIQUE BELTING, WE ARE IN A POSITION TO GUARANTEE SHIPMENT OF ALL ORDERS THE DAY FOLLOWING THEIR RECEIPT.

# Unger Bros.,

192 BROADWAY,  
NEW YORK.

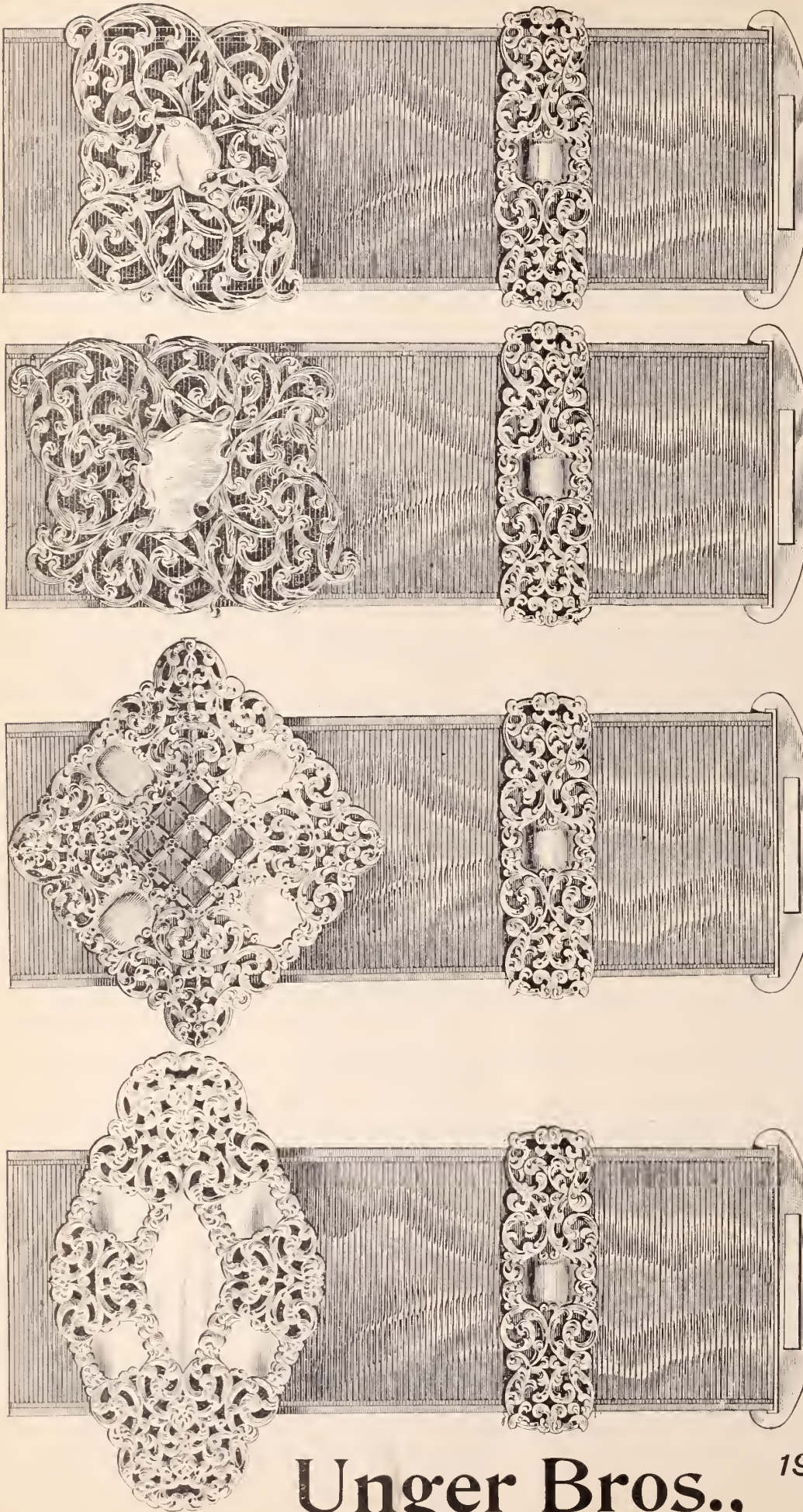



# The Jewelers' Circular

AND

HOROLOGICAL REVIEW.

PUBLISHED EVERY WEDNESDAY BY

THE JEWELERS' CIRCULAR PUB'G CO.,

189 BROADWAY, NEW YORK CITY.

A JOURNAL DEVOTED TO THE INTERESTS OF JEWELERS, WATCHMAKERS, SILVERSMITHS, ELECTRO-PLATE MANUFACTURERS, AND ALL ENGAGED IN KINDRED BRANCHES OF INDUSTRY.

Our Editorial columns will contain our own opinions only, and we shall present in other columns only what we consider of interest or value to our readers. Advertising matter will not be printed as news.

Advertising rates in THE CIRCULAR are lower, considering the number of tradesmen reached by its large circulation, than in any other jewelry journal.

Notices of changes in standing advertisements must be received one week in advance; new matter can be received up to Monday.

## INFORMATION FOR SUBSCRIBERS.

### Terms of Subscription, Postage Prepaid.

	PER ANNUM
United States and Canada, . . . . .	\$2.00
Foreign Countries in Postal Union, . . . . .	4.00
Single Copies, . . . . .	.10

New subscribers can commence at any time. Payments for THE CIRCULAR, when sent by mail, should be made in a Post Office Money Order, Bank Check or Draft, or an Express Money Order or Registered Letter. All postmasters are required to register letters whenever requested to do so. Pay money only to authorized collectors having proper credentials. Returning your paper will not enable us to discontinue it, as we cannot find your name on our books unless your address is given. In changing address always give the old as well as new one. Your name cannot be found on our books unless this is done. We will continue to send papers until there is a specific order to stop, in connection with which all arrearages must be paid; but such an order can be given at any time, to take effect at the expiration of the subscription. All such orders will be promptly acknowledged by mail. The Courts have decided that all subscribers to journals a responsible until arrearages are paid in full and an order to discontinue has been received by the publisher.

Member of the American Trade Press Association.

VOL. XXVIII. March 21, 1894. No. 7

### Export Trade to the Southern Nations.

THE Spanish-American edition of THE CIRCULAR, which has been in preparation for some time past will be issued within 10 days. It will be circulated, as announced during the past month in the countries of Mexico, Cuba, Central America and South America, and will be printed both in respect to reading matter and advertisements in pure commercial Spanish, the language which almost exclusively obtains in the southern nations of America. The purpose of this edition, as set forth in the prospectus of the management of THE CIRCULAR is to bring prominently before the jewelers of these countries, for their consideration, the character of American products adapted to their business and the advantages that will accrue to these merchants in handling them. American manufacturers, it is admitted, control less than their share of Mexican and South American trade, the factory owners of Germany,

## Spanish-American Edition of The Jewelers' Circular.

The forms of the Spanish-American edition, to be circulated in South America (east and west coasts), Cuba, Mexico and Central America, are now being prepared and advertisers are earnestly requested to forward copy for their announcements at the earliest possible moment. Copy for advertisements is to be sent to us in English, which we will properly translate into Spanish. If you desire space in this number please communicate with us AT ONCE as only a limited amount is now open; rates will be made known upon application.

Yours truly,  
The Jewelers' Circular Publishing Co.

France and England, absorbing almost the entire import business. An apparently disinterested correspondent writes from the City of Mexico: "With interests in bonanza mines, and immense profits, no wonder merchants grew very rich, and small marvel that the Germans were attracted to this rich field, and drove out the older race of English merchants by sheer force of superior mercantile organization and economy of management." The German brings to merchandizing wonderful tact, great adaptability to the people, a talent for languages, and indomitable persistence. His most successful rivals are the French, who have seized on the dry goods trade. The American possesses as telling qualities as either the German or Frenchman, if he will but exercise them. The correspondent before quoted speaking of the Mexican jewelry trade has the following to say: "Jewelers do a good business and get rich, for this is the land of gift-making, and we all know that it is present-giving that sustains the jeweler in all countries. And then, too, there is a strong national liking for jewelry, as is evidenced by the superb displays in the windows of Plateros St., the very name Plateros, or 'Silversmiths,' indicating that anciently, as it is now, it was the haunt of the sellers of this class of goods. Splendid stocks of articles of luxury, of bronzes, rich china, etc., are carried here. When a jeweler of the first rank here fails in business, make a note of it, for you will not have another chance in a round century!" Allowing that this is a somewhat roseate view of the jewelry industry in Mexico, it cannot be gainsaid that the land of the Montezumas, as well as Cuba and South America where a large demand for jewelry, silverware and kindred lines prevails, is a desirable field for the operations of American manufacturers in these lines; and it is with a view to fostering their endeavors that THE CIRCULAR issues its Spanish-American edition. It is not necessary to discourse here on the systems of customs duties, transportation, banking institutions, etc., obtaining in the various countries, as a comprehensive knowledge of these matters can be obtained from the publications of the Bureau of American Republics, which will be furnished merchants upon application.

## The Week in Brief.

THE business of Giles, Bro. & Co., Chicago, will probably be continued by a new company—The death occurred of Thomas S. Negus, New York—A motion to annul the indictment against B. Williams, of the Du Laney Clock Co., Valparaiso, Ind., was sustained—The Bowden Bill increasing peddlers' license, was passed by the Kentucky Legislature—H. R. Phillips, Chicago, is reported to be dying—A suit against the defunct San José Watch Co., of Alviso, Cal., was dismissed—Another enormous deal in diamonds was reported from Kimberley—Vincent Delales, Philadelphia, Pa., was arrested charged with fraudulently appropriating partnership property—Hon. Carroll D. Wright, Commissioner of Labor, in charge of the 11th Census, transmitted his report to the Secretary of the Interior—The Eastman Clock Co., Boston, Mass., incorporated—A meeting of the creditors of W. S. Taylor & Son, Utica, N. Y., was held in New York.—The jewelers of Nebraska formed a State association—The death occurred of Stephen P. Mockeridge, Newark, N. J.—Suit was entered against L. H. Goldsoll & Bro., Cleveland, O.—E. H. Desleins, Ada, O., assigned—The Sloan & Chace Mfg. Co., limited, Newark, N. J., incorporated—The Tiffany collection of precious stones exhibited at the World's Fair, was sold to the Field Columbian Museum, of Chicago.—Jas. R. Feeley & Co., Providence, R. I., made an assignment—The Rhode Island Senate passed a resolution to adopt a silver standard—The assignee of Harrington & White, Providence, R. I., made a statement public—A compromise offer will probably be made by the assignee of the Seery Mfg. Co., Providence, R. I.—Frank D. Enney, Syracuse, N. Y., gave a bill of sale.

### Death of Stephen P. Mockeridge.

NEWARK, N. J., March 20.—Stephen P. Mockeridge, one of the oldest manufacturing jewelers in Newark, died at his home in this city on Sunday night of heart disease. He was born in Newark seventy-one years ago, and had been engaged in the jewelry business for over thirty years.



### New York Notes.

W. Bolle has entered a judgment for \$724.74 against Isaac Rosowsky.

A judgment for \$468.28 has been entered against Nathan Frank by S. Firuski & Son.

Benj. F. Spink will on May 1st remove his store from 359 Sixth Ave. to 275 Sixth Ave.

Wm. H. Heathcote will remove his store under the *Times* building, to 679 Broadway, on May 1st.

J. W. Riglander, of Hammel, Riglander & Co., sailed for Europe Saturday on *La Champagne*.

W. H. Eggert has started in business as a dealer in diamonds and watches, at 2 Maiden Lane.

A judgment against Moses J. Lichtenberg for \$152.91 has been entered by T. F. Arnold and others.

W. T. Rehm, 75 Nassau St., has given a chattel mortgage on opticians' fixtures to Arthur Pratt for \$3,000.

F. Wm. Barthman, Jr. is on a pleasure trip with his wife to Old Point Comfort, Va., and Atlantic City, N. J.

Seckels & Oppenheimer, importers of diamonds, will remove May 1st from 19 Maiden Lane to 45 Maiden Lane.

J. M. Pedersen, 50 Nassau St., has given a chattel mortgage for \$235, to the executor of the estate of Jens F. Pedersen.

Wm. H. Ball, of Wm. H. Ball & Co., 15 John St., returned, Saturday, from a short pleasure trip to Atlantic City, N. J.

Deputy sheriff McGinness Thursday sold out the machinery and effects of Henry Blog, diamond polisher, 100 Nassau St.

Paul E. Treibs, of Treibs Bros., importers of precious stones, 41 Maiden Lane, sailed for Europe Saturday on the *Lahn*.

Alfred F. Cross, president of the Cross & Beguelin corporation, is with his family spending a few weeks at Lakewood, N. J.

W. Näf, dealer in imitation stones, and A. Wolff, importer of music boxes, both formerly of 194 Broadway, are now in temporary quarters at 111 Nassau St.

The assignee's sale of the stock and fixtures of Simon Dessau, 4 and 6 John St., took place at that address, Thursday. The amount realized was but \$684.85.

The city of Florence, S. C., has purchased through Isaac Sulzbacher & Son, jewelers of that city, a 1,200 pound bell and a tower clock made by The E. Howard Watch & Clock Co.

Arnold Kohn, of Alois Kohn & Co., was one of the jurors in Part I. of the Court of General Sessions last week who convicted Mary Dunn, accused of killing her husband, of manslaughter in the second degree.

President Lissauer, of the Jewelers' Relief Association, has called a meeting of the full committee of 25 for this afternoon. Reports of the work done will be submitted, and other important business transacted.

Leopold Stern, dealer in silverware and bronzes, and United States agent for the Wurtemberg Silver Co., Geislingen, Germany, will give up his office at 41 Maiden Lane May 1st, and will wind up his present business.

In a suit brought by Henry Weil against Simon Dessau to foreclose a mortgage of \$60,000, on property at Broadway and Eighth St., Judge McAdam, of the Superior Court, Thursday rendered a decree for the plaintiff. The amount found due is \$70,170.40.

Justice Voorhees, in the Yorkville Police Court, last week, held Eliza Welch, 38 years old, of New Haven, Conn., for trial on the charge of shoplifting. She was accused of stealing goods from the jewelry department of Bloomingdale Bros., 59th St. and Third Ave., on March 13th.

In the suit of Alfred H. Smith & Co. against the American Turquoise Co., the General Term of the Supreme Court, Friday, heard the appeal of the plaintiffs from an order denying their motion to strike out certain parts of the defendant's answer as irrelevant and immaterial.

Ga Nun & Parsons, opticians, 5 E. 42d St., have made application to compel Clara M. Price to undergo an examination of her eyes, in advance of the trial of her suit against them to recover \$5,000 damages for impaired eyesight from wearing improper glasses purchased at the defendant's store.

Abel King, who has been connected with I. Emrich & Co., 52 Maiden Lane, for the past 12 years, was recently admitted as a partner in that firm. Mr. King and another partner, Isaac Schorch have returned from Europe, where they scoured the market for novelties, which their house is receiving by every incoming steamer.

The suit of interpleader brought in the Supreme Court, Brooklyn, by the Jewelers' League, to determine to whom the \$5,000 insurance on the life of Chas. S. De Forest should be paid, has been decided by Judge Cullen. De Forest died Dec. 22, 1892, and his wife and mother both claimed the insurance. Decision was given in favor of the wife, Mrs. Annie De Forest.

In the Essex Market Police Court, Friday, Justice Hogan committed to the care of the Gerry Society, two twelve year old boys, David Lippmann and Isaac Madofsky, who were charged with stealing jewelry from Simon Harris, 402 Grand St. The boys had removed a broken pane of glass in Harris's jewelry store, and with a wire hook captured three gold rings valued in all at \$80.

The appeal in the suit of Edith M. Faxon against John Mason, from the judgment entered in favor of the plaintiff after trial at Special Term, has been decided by the General Term of the Supreme Court. This is the suit brought by Mason's sister, in which his assignment was set aside. By the opinion of the General Term filed Friday, the judgment is modified so that the assignee is not charged personally with the costs of

action, and the judgment as modified is affirmed with costs.

The wonderful Tiffany collection of gems and precious stones exhibited at the World's Fair, has been sold to the Field Columbian Museum, of Chicago. The price paid is said to be \$100,000. This collection is regarded as one of the most important additions that has been made to the museum.

By an order signed by Judge Gaynor in the Supreme Court, Brooklyn, last week, all persons interested in the firm of Jas. H. Hart, limited, were required to show cause Thursday, why the corporation should not be dissolved. The application was made by a majority of the directors, on the ground that the firm had impaired its capital. A full account of the reasons for this dissolution appeared in *THE CIRCULAR* two weeks ago.

United States Commissioner Shields Saturday held for trial Leonardo Bassadera, an Italian, arrested the previous day for having stolen a quantity of cheap jewelry at the barge office from a case containing a large quantity of pinchbeck articles which were to be sold for duty. The prisoner explained to the Commissioner that he took the jewelry as samples to show to friends in his neighborhood in Mulberry St., who might like to attend the sale and make purchases.

An order in the suit of Adolph Bechtold vs. Jos. J. Clairmont, signed by Judge Ingraham, of the Supreme Court, Thursday, authorized the receiver of Clairmont & Co., opticians in E. 23d St., to pay Levy, Dreyfus & Co., \$465.97 which is the amount of their claim against that firm. In a deposition made by the attorney for the receiver, he states that the total debts owing by Clairmont & Co. did not exceed \$2,591.15, while the assets which he sold realized \$13,000, leaving a surplus of more than \$10,000.

The Jewelers' Individual Bowling Club continued their games at Thurmann's alleys, 98 Gansevoort St., Monday night. A feature of the evening was the score of 231 rolled by Mr. Shiman. The following is the result:

Woodland vs.	157	2d game	139
Ruefer	102	"	166
Hovet vs.	162	"	156
Mangold	182	"	122
Shiman vs.	185	"	152
Thompson	138	"	142
Clifford vs.	135	"	165
Sachs	146	"	149
Woodland vs.	142	"	122
Shiman	157	"	165
Hovet vs.	177	"	165
Clifford	139	"	110
Thompson vs.	150	"	148
Ruefer	138	"	167
Mangold vs.	113	"	120
Sachs	133	"	164
Woodland vs.	152	"	171
Thompson	133	"	142
Hovet vs.	163	"	136
Sachs	153	"	139
Ruefer vs.	170	"	183
Shiman	158	"	231
Mangold vs.	106	"	119
Clifford	138	"	100



# L. TANNENBAUM & CO.,

IMPORTERS AND CUTTERS OF

## DIAMONDS • AND • PRECIOUS • STONES.

Cor. Maiden Lane & Nassau St.,  
NEW YORK.

25 HATTON GARDEN,  
LONDON.

TELEPHONE,  
Long Distance,  
1959 CORTLANDT

IN ORDER TO REDUCE OUR ENORMOUS STOCK WE OFFER THIS WEEK AT  
SPECIAL PRICES, THE FOLLOWING GOODS:

Rough Siam Rubies for cutting purposes, at 50c. per karat.  
Rough Fancy Sapphires for cutting, at 25c. per karat.  
Rough Sapphires for mechanical use, and precious  
stones for collections.

We will offer as special bargains this week, the following lots:

Lot 6,207	Sapphire, 30 37-64 kt.,	at \$1.00 per kt.
" 4,206-133	" 36 42-64 kt.,	at 3.25 "
" 4,203-4	Cabochon, 12 20-64 kt.,	at 2.00 "
" 5,203-6	" 4 23-64 kt.,	at 2.00 "
" 3,202-4	" 9 10-64 kt.,	at 2.50 "
" 21,242	18 Spinel, 12 less 3-64 kt.,	at 7.50 "
" 22,242-5	Fancy Sapphire, 8 42-64 kt.,	at 3.00 "
" 24,242-27	Pink " 12 47-64 kt.,	at 6.00 "

Lot 25,242-23	Pink Sapphire, 12 39-64 kt.,	at 4.50 per kt.
" 26,242-20	Fancy " 21 4-64 kt.,	at 4.00 "
" 2,100-9	" Pearls, 78 3/4 gr.,	at 2.50 per gr.
" 5,100-87	Pearls, 113 1/8 gr.,	at .32 "
" 6,100-47	" 121 less 1-16 gr.,	at .50 "
" 11,100-2	" 16 gr.,	at 2.50 "
" 12,100-12	" 47 1/4 gr.,	at 1.50 "
" 8,101-65	" 74 1/4 gr.,	at .30 "
" 2,107-2	Spinel, 2 40-64 kt.,	at 15.00 per kt.
" 16,112-1	Yellow Sapphire, 4 52-64 kt.,	20.00 stone.
" 6,112-1	" 14 32-64 kt.,	at 3.00 per kt.
" 27,117-1	Star Ruby, 3 33-64 kt.,	75.00 stone.
" 20,117-1	Star Sapphire, 8 less 3-64 kt.,	15.00 "
" 10,121-1	Yellow Sapphire, 5 41-64 kt.,	25.00 "
" 20,121-1	Alexandrite, 13 less 1-64 kt.,	150.00 "

# Battin & Company,

MAKERS OF

Gold • and • Silver • Novelties,

Third Ave. & Ogden St.,

Newark, N. J.

STERLING SILVER SILK  
WINDERS.

EXACT SIZES.

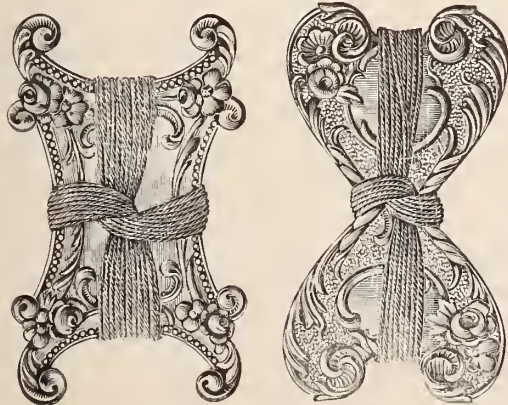

\$9.00 PER DOZ.

\$9.00 PER DOZ.



STERLING SILVER TOP,  
RED SILK EMERY BAGS.

EXACT SIZES.



\$9.00 PER DOZ.

\$6.00 PER DOZ.

ORIGINAL DESIGNS.

BEST FINISH.

POPULAR PRICES.



### Last Week's Arrivals.

*THE CIRCULAR has perfected arrangements for obtaining the names and hotel addresses of all the latest buyers visiting New York, and each day posts in its office, 189 Broadway, a bulletin which every member of the trade is cordially invited to copy.*

The following out-of-town dealers were registered in New York during the past week: A. Kipp, Indianapolis, Ind., St. Stephen H.; W. B. Whitcomb, Boston, Mass., Broadway Central H.; F. M. Brown, New Haven, Conn., 70 Worth St.; C. E. Child, Warren, R. I., Astor H.; H. Koch, Milwaukee, Wis., St. Nicholas H.; W. Williams, Chicago, Ill., Gedney H.; D. A. Freeman, Boston, Mass., Murray Hill H.; D. E. Dunn, Fort Plain, N. Y., Imperial H.; A. Klein, Cincinnati, O., New Netherland H.; H. W. King, Cleveland, O., Murray Hill H.; R. W. Hyman, Chicago, Ill., Imperial H.; L. E. Kirstein, Rochester, N. Y., Imperial H.; J. Anderson, Toronto, Ont., Gedney H.; D. O'Hara, Waltham, Mass., Astor H.; James P. Rule, buyer for D. McCarthy & Son, Syracuse, N. Y., 43 Leonard St.; A. Levy, Hamilton, Ont., Astor H.; W. H. Zinn, Lafayette, Ind., Imperial H.; C. E. Wiggington, buyer for Woodward & Lathrop, Washington, D. C., St. Denis H.; R. Leding, Washington, D. C.; E. Emery, Jr., Bradford, Pa., Imperial H.; W. H. Hansell, Philadelphia, Pa., Astor H.; H. Koll, Milwaukee, Wis., St. Nicholas H.; E. Beck, Cincinnati, O., Marlborough H.; A. H. Pray, Boston, Mass., Barrett H.; F. Harrington, Boston, Mass., Astor H.; J. Brennon, Bradford, Pa., Broadway Central H.; O. Young, Chicago, Ill., Holland H.

Ryan, Barrows & Parker, and W. C. Newman, Middletown, Conn., have bought the business of John C. Irving, Hagerstown, Md., which will be conducted by W. C. Newman under the name of W. C. Newman & Co.

### Connecticut.

Capt. and Mrs. D. B. Hamilton, of Waterbury, are now sojourning at Hotel Brunswick in Los Angeles, Cal.

W. W. Myatt left Meriden last Tuesday night on a two months' business trip through the west, in the interest of the Meriden Britannia Co.

The work of remodeling the main offices of the Meriden Britannia Co. has been commenced. The offices are among the handsomest in the State.

Judge Hubbard has, as counsel for the Housatonic Mfg. Co., Wallingford, filed with the town clerk an affidavit of the increase of \$12,500 in the capital stock of the company.

The wedding of Miss Helen M. Spargo and William H. Saxton, Jr., the jeweler of New London, took place last week at the home of the bride's mother. Mr. and Mrs. Saxton left for a short stay in Boston.

Burglars broke into Marshall P. Ryder's jewelry and variety store in Plainville, last Tuesday night and stole about \$50 worth of goods. An entrance was effected by breaking into a window on the post office side.

The Hon. Samuel Simpson, one of Wallingford's most venerable citizens, lies critically ill at his residence and it is feared that he cannot long survive. For some time he has been suffering from a cancerous growth, which is rapidly nearing the vital parts and the patient is a great sufferer. Mr. Simpson is one of the pioneers of the silverplated ware industry in this country.

Henry L. Beach, who has been for thirty-two years superintendent of the case department of the E. Ingraham Co., Bristol, has tendered his resignation which has been accepted. He will not conclude his services at present. His successor is William Wright. Mr. Beach, during his years of efficient service, has seen this concern grow from a comparatively small one to become one of the largest and best of its kind in the United States.

The Standard Electric Time Co., New Haven, of which C. D. Warner, of Ansonia, was the secretary, treasurer and general

manager, has been sold outright to Waterbury capitalists. Some time ago George E. Judd, bookkeeper in the Waterbury National Bank offered to pay a certain price for the stock if he could purchase all of it. This deal was consummated Wednesday, and Mr. Judd then disposed of part of the stock to three other men. As the stock of 575 shares is now divided Mr. Judd and Mr. Wade have the greater part, while A. M. Blakeslee, cashier of the Waterbury National Bank, and C. D. Warner each have stock worth \$1,000. As soon as the business had been brought to a conclusion the following officers of the company were elected: H. L. Wade, president; George E. Judd, treasurer; C. D. Warner, secretary and general manager. Mr. Wade is president of the Waterbury Clock Co. and is greatly interested in the development of the system of electrically operated clocks.

### Boston.

N. G. Wood has returned from a brief outing in Florida.

The American Waltham Watch Co. have paid a semi-annual dividend of 4 per cent.

Buyers in Boston last week included C. B. Duckworth and A. R. Vaughan, Pawtucket.

The annual meeting of the American Waltham Watch Co. will be held March 29, in Waltham.

William S. Brown, head bookkeeper for the E. Howard Watch & Clock Co., is in New York on a trip that combines business with pleasure.

Harry H. Vaughan, salesman for Smith & Patterson, who has been under the weather lately, has so far recovered as to be able to return to business.

A telegram announcing the serious illness of his mother, caused Herbert W. Richards to abandon his trip to California last week. He had passed Chicago on his journey when the message reached him.

Striking tower clocks are under construction by the E. Howard Watch & Clock Co. at the City Hall and opera house, Sumter, S. C., and City Hall, Florence, S. C.; also a large regulator controlling 30 dials in the Prudential Life Insurance building, in Newark, N. J.

The Eastman Clock Co., with principal office in this city, have incorporated with a capital stock of \$12,000 to manufacture, purchase and sell clocks and to prosecute any or all business incidental thereto. The incorporators are: Jos H. Eastman, 171 Blue Hill Ave., Chas. D. Wainwright, 28 State St., Harry W. Pidgeon, 18½ Richfield St., all of Boston.

J. E. Hardwick, an auctioneer, was arrested last week on the charge of embezzlement and also larceny of property, from N. H. Brown, dealer in clocks, 90 Franklin St. One of the warrants alleges that he embezzled property amounting to \$287 and also stole property to the value of \$415. A second warrant alleged the embezzlement of \$45 and the larceny of \$45.

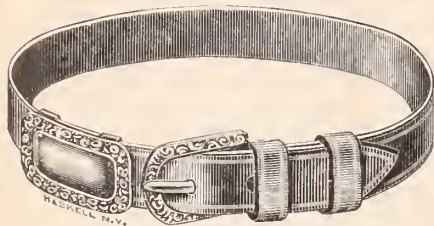

### UMBRELLA STRAPS

STERLING  
SILVER  
BUCKLES  
& SHIELD.

Send  
for  
Sample.

HENRY C. HASKELL, Maker, - 11 JOHN STREET, NEW YORK.

We Have Removed to **57 MAIDEN LANE.**  
**LEONHARDT & CURRAN,**  
MANUFACTURERS OF DIAMOND MOUNTINGS.



**Providence.**

Mr. and Mrs. Charles H. Fuller are contemplating a European tour next Summer.

William Pearson, formerly with Crossin & Tucker, is now salesman for Thomas W. Lind.

William F. Leeder, of Leeder & Bernkopf, is expected home from his European trip about April 1.

The Tilden-Thurber Co. have been granted power by the General Assembly to issue preferred stock.

A judgment has been secured by Julius Eichenberg for \$194.04 against Coombs & Atkinson, Pawtucket.

Charles W. Battey has returned from an extended western trip in the interests of Waite, Mathewson & Co.

The case of Frederick D. Williams against S. & B. Lederer will be called in the Court of Common Pleas this week.

The directors of the Manufacturing Jewelers' Board of Trade met in their rooms in the Wilcox building on Saturday.

Thomas W. Lind has so far recovered from his long illness as to be able to visit his place of business every pleasant day.

Holden & Knox have removed from 66 Stewart St. to 95 Pine St. where they will occupy a portion of W. C. Greene & Co.'s shop.

It is thought that assignee Phineas F. Parsons will be able to offer the creditors of the Seery Mfg. Co. a compromise offer of 25 or 33 1/2 per cent.

In the Court of Common Pleas before Judge Rogers the past week, A. T. Wall & Co. obtained a *nil dicit* judgment against Potter, Read & Co., of this city for \$528.92.

George C. McCormick has the sympathy of a large circle of acquaintances in the ill luck that has been visited upon him during the past few months. Since his forced assignment of a few weeks ago one of his children have died, the other as well as his wife has been dangerously ill, while he himself has been confined to his house by illness.

J. Rathbone, assignee of Harrington & White, has made a statement that the liabilities of the concern will amount to \$5,996.76 and that the assets are \$1,500.70, including book accounts to the amount of \$740. Among the heaviest creditors are Albert Lorsch & Co. for stones, Allen &

Jonassohn, stones, Thomas W. Lind, findings, and George Sturdy, coloring. It is reported that an offer of 15 per cent. has been made to the creditors and that it will probably be accepted.

**James R. Feeley & Co. Make an Assignment.**

PROVIDENCE, R. I., March 15.—James R. Feeley & Co., manufacturing jeweler, 129 Eddy St., made an assignment late yesterday afternoon to George L. Vose, of G. L. Vose & Co. General business depression and a number of uncollectable bills were the cause.

The concern consists of Mr. Feeley only, the company being merely nominal. Mr. Feeley was for many years a partner with Michael Fitzgerald, but withdrew from that concern in 1885, starting in business alone. In the early part of 1886, however, he took in as a partner William D. Wolf, who withdrew in 1887. Later Mr. Feeley associated himself with James H. Bashford, for many years bookkeeper for M. Fitzgerald. They dissolved partnership in 1890 and since that time Mr. Feeley has continued alone. He has had a small rating at the agencies for some time and has been considered slow pay for nearly two years. The extent of the assets and liabilities is unknown.

**Silver Standard Adopted by the Rhode Island Senate.**

PROVIDENCE, R. I., March 15.—Last week a resolution was introduced into the General Assembly as reported in the last issue of THE CIRCULAR and referred to the judiciary committee providing that all goods marked "sterling" or "sterling silver" shall contain not less than 92.5 per cent. of pure silver, and that all goods marked "coin" or "coin silver" should contain not less than 90.1 per cent. of pure silver, and that the offering for sale of any goods not up to these standards shall be a misdemeanor. This was referred back for the reason that there was no penalty attached to the breaking of this law.

Yesterday, however, in an amended form, that is with a clause added which provides that "any person convicted of a violation of the provisions of the act shall be imprisoned not to exceed six months and fined not to exceed \$500" the resolution was passed by the Senate. It is understood that this act was introduced at the suggestion of the Gorham Mfg. Co.

**SILVER**  
**Deposit Cologne.**

PURE SILVER <sup>1,000</sup>/<sub>1,000</sub> FINE.



**ALVIN MFG. CO.,**  
**860 BROADWAY, NEW YORK.**



SPECIALTY: SALES OF  
**JEWELRY, BRIC-À-BRAC**  
AND  
ARTICLES OF VERTU

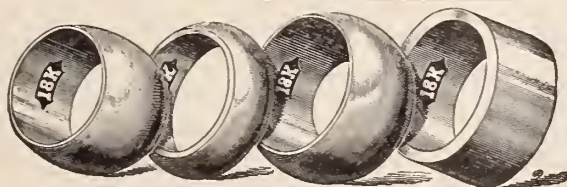

Band Rings metal lapped. Full value allowed for old gold.

**PLAIN SOLID GOLD RINGS.**  
**HILDRETH MFG. CO.,**

53 MAIDEN LANE,

NEW YORK.



THE STAR OF EMPIRE WESTWARD TAKES ITS WAY

# WESTERN SUPPLEMENT of THE JEWELERS' CIRCULAR

Chicago Office: Room 517, Inter-Ocean Building.

VOL. XXVIII.

CHICAGO, WEDNESDAY, MARCH 21, 1894.

NO. 7.

### Chicago Notes.

F. A. Hardy numbers among the returned visitors from the Mid-Winter Fair.

Tool and material houses report that they were kept unexpectedly busy the past week on general orders.

Good reports are being sent in by Mr. Katlinsky, of Katlinsky & Gatzert, now on the road in Illinois.

O. Fulbe, 377 W. Division St., has returned from a two months' tour of California in search of pleasure.

S. N. Jenkins, manager for Aikin, Lambert & Co.'s Chicago office is visiting Indiana customers.

Geo. Hueston, of the Waltham Watch and Jewelry Co., has returned from an extended cruise in a steam yacht in Florida waters.

Dave Drummond, La Crosse, Wis., whose failure was noted some months ago, is doing business at that city as E. Horner.

The Chicago office of THE JEWELERS' CIRCULAR, in the *Inter-Ocean* building, has been removed from room 308 to room 517.

R. M. Johnson will return in a few days from a three weeks' pleasure visit at West Baden Springs, Ind., and Hot Springs, Ark.

T. D. Brewster, Jr., for the Weber Co., left Thursday for Illinois and Iowa, and looked forward to a fair business.

W. S. & J. B. Wilkinson will occupy their new quarters on the fourth floor of the Masonic Temple, the latter part of the week.

E. S. Whitehead, 941 W. Lake St., has moved into a larger and finer store on the north side of the street, opposite his former location.

Chas. P. Gregg & Co., formerly at suite 25 Commerce building, moves into new quarters in the Bort building, on Quincy St., the present week.

Mr. Marcellus, formerly of McBride & Marcellus, Cleveland, O., was in town the past week, and expects to again enter the ranks of jewelers.

Mrs. Curtis, mother of Wm. G. Curtis, formerly of Reilly & Curtis, has bought the business of R. K. Reilly, 233 State St. Mr. Curtis will manage the store.

A. C. Becken returned, Wednesday, from an inspection of his ranch properties near Ojo Caliente, N. M. Mr. Becken recently purchased the Kelly ranch, a valuable property in the San Mateo foothills.

The Towle Mfg. Co. started out a new man the past week, A. H. Atwood, giving the house one more traveler than they ever before had. Mr. Atwood will look after the largest cities in the central States.

By the tearing down of a dividing wall the offices of Stern Bros. & Co., Martin, Copeland & Co., and the Roy Watch Case Co., 140 State St., are combined in a light sales-room which gives added advantages to each of the firms.

A bill of sale has been recorded for jewelry, etc., at 6203 Commercial Ave., E. Keller to C. Leseberg, the consideration being \$31. Feb. 1st last, Keller gave Leseberg a two years' chattel mortgage on jewelry, etc., for \$2,412.

John C. Leppert, jeweler, 155 S. Halsted St., was awakened at 1 A. M. recently by a telegraph pole aflame in front of his store. A hot fire was raging in a clothing store next door, but the jewelry store escaped with a slight scorching of the wooden front.

Geo. Lunt, a traveler for the Towle Mfg. Co., was robbed of his grip, containing only personal apparel, at the hotel of a small station near Monterey, Cal. The thief evidently expected to make a haul of silver goods and in his disappointment slashed the grip with his knife and left it at the railway station. A fine pipe and minor articles of clothing were missing. Mr. Lunt carries a new grip at the expense of the hotel proprietor.

F. J. Essig, lapidist, 1222 Masonic Temple, has added to his well-equipped work-rooms a diamond cutting machine and will hereafter add diamond work to his repair

list. Previously all stones had been sent east, but the demand for matching, repolishing, and recutting faulty, chipped or broken demands is constantly increasing, and again the west breaks away from the eastern yoke. "So long as diamonds are not found in large quantities in this country, it will not pay us to put in an extensive plant," said Mr. Essig, "but we can now cut anything, from a diamond to a lump of putty." The new machine will be in charge of Frank Essig, an expert workman.

Unidentified property held by the Iest and found department of the World's Fair was disposed of at auction at the Fair grounds, Thursday. Bidding was spirited, but low prices ruled. The jewelry display was bought by C. C. Munger at the following figures: 72 bracelets, 22 cents each; 100 eye-glasses, 7 cents each; 76 spectacles, 10 cents a pair; 100 rings, 55 cents each; 7 opera glasses, \$1 a pair. Abraham Siegel bought two dozen gold watches at \$3.50 each.

H. F. Hahn & Co. started the movement toward the Champlain building, N. W. corner State and Madison St., by taking the third floor. The past week the agent of the building has been actively at work among the jewelers with good results. F. E. Morse Co. have leased a front space on the sixth floor to be occupied as diamond rooms from May 1st. This move was necessitated by the tearing down of the Hale building, 100 State St., the firm's present quarters on that date to make room for a "sky scraper." S. N. Clarkson & Co., 182 State St., will occupy rooms on the ninth floor; C. W. Ternandt & Co., 155 State St., will occupy part of the tenth floor, and Pentz & Co. have leased quarters on the fourteenth. The leases run from two to five years. It is understood a number of jewelers are negotiating for space in the building and will shortly sign leases.

Joseph Sutter, jeweler, Plattsburg, Mo., has opened a branch at Edgerton, Mo., and has put his son in charge of it. He was in Kansas City last week buying his stock,



**A New Company to continue the Business of Giles, Bro. & Co.**

CHICAGO, Ill., March 17.—The wisdom of the request made by R. A. Kettle, Feb. 26, that the sale of the assets of Giles, Bro. & Co., be postponed to March 10, he believing a larger amount could be secured by postponement, was shown in the sale on the latter date, as stated in last week's CIRCULAR, of the stock and State St. leasehold of the firm to H. D. Spaulding, of Boston, for \$39,000, an increase of \$11,000 over the highest bid of Feb. 26. Mr. Kettle was trustee of the judgments held by the American Waltham and Elgin watch companies, of a face value of some \$15,000. L. L. Coburn, of the law firm of Coburn & Thacher, acted for Mr. Spaulding.

When the court called for bids a suggestion was made that the leasehold interest in 221-223 State St. be separated from the jewelry stock, as offers would be received from different parties. Bidding opened with \$1,000 for the leasehold, and A. G. Schwab & Bro., Cincinnati, offered \$30,000 for the jewelry stock. An offer of \$32,000 was made for the entire assets, including leasehold, by H. D. Spaulding. The leasehold man raised his bid to \$2,000 and Schwab & Bro. increased to \$31,500. Spaulding's attorney came back with \$34,000. Schwab offered \$33,000 and leasehold went to \$2,500. Spaulding said \$36,000. Cincinnati offered \$34,000, leasehold still at \$2,500. Boston bid \$37,000. Leasehold went to \$3,000 and

jewelry to \$35,000, a total of \$38,000, and Spaulding bid \$38,500. The leasehold was then advanced to \$3,750 but the Cincinnati jewelers refused to raise their bid and on a total bid of \$39,000 the property was struck off to Spaulding.

A deposit of \$1,950 was made and the balance will be paid in on the request of the court. Mr. Spaulding is a young man, a friend of W. A. Giles, and efforts will shortly be made to form a company to continue the business under its former management. It has always been C. K. Giles' desire to again manage the affairs of the company, and it would seem there is little now in the way of its accomplishment. Mr. Spaulding will be a silent partner in the new firm, but further than this the plans have not crystallized.

**Watch Inspection on the Illinois Central Railroad.**

CHICAGO, Ill., March 16.—The largest inspection report of railroad watches ever sent out was that just made by J. W. Forsinger, general inspector for the Illinois Central Road. The following inspectors, prominent jewelers in their respective towns, contributed to the report:

J. W. Forsinger, Chicago; A. M. Wilton, Burnside Crossing, Ill.; C. J. Linden, Kankakee, Ill.; M. G. Mohler, Gilman, Ill.; Ozias Riley, Champaign, Ill.; J. W. Bradford, Centralia, Ill.; J. J. Higgins, DuQuoin, Ill.; John A. Miller, Cairo, Ill.; C. A. Church, Amboy, Ill.; W. E. Birkenbeuel,

La Salle, Ill.; Otto E. Curtis & Bro., Decatur, Ill.; E. E. McIntosh, Clinton, Ill.; J. C. Klaholt, Springfield, Ill.; H. B. Clark, Rantoul and Leroy, Ill.; A. V. Hart, Freeport, Ill.; N. E. Benoit, Rockford, Ill.; Lange & Lange, Dubuque, Ia.; D. R. Lewis & Bro., Manchester, Ia.; Balliett & Weld, Waterloo, Ia.; Carter, Meservey, Hurlbut Co., Ft. Dodge, Ia.; A. H. Smith, Cherokee, Ia.; W. H. Beck, Sioux City, Ia.; W. H. Booth, Sioux Falls, S. D.; Geo. E. Gail, New Orleans, La., and Macomb City, Miss.; T. C. Siede, Canton, Miss.; E. V. Seutter, Jackson, Miss.; A. Barber, Durant, Miss.; A. Graves, Memphis, Tenn.; W. E. Smith, Grenada, Miss.; B. O. Sneider, Jackson, Tenn.; Johnson Ater, Water Valley, Miss.; Henry Yoste, Vicksburg, Miss.; Aug. Zurhellen, Natchez, Miss.

The result of their work is shown in the following summary:

Examined.....	4,054
Compared with standard time weekly.....	1,796
Average days run since setting for rated watches.	24
Average daily variation in seconds for rated watches .....	.6
Rejected as unsafe.....	18

The report speaks for itself in the efficient and thorough work shown. There was an increase of about 500 in the number of employees whose watches were examined.

**H. R. Phillips Nearing the End of Life's Span.**

CHICAGO, Ill., March 17.—H. R. Phillips, well-known the country over, lies dying at

**TWO OF A KIND !!**



Two of a kind is a good hand to draw to, especially if they're a big two, like Messrs. Joy and Happy above. These two win others to their standard.

JEWELER JOY—Where do you send your sweeps and old gold and silver, Happy?

JEWELER HAPPY—The last went to Goldsmith Bros.

JOY—Where'll you send the next?

HAPPY—Straight to the Goldsmith boys. Their tests are accurate and their valuations correct, and besides they remit by cash or draft on receipt of shipment, and if offer is not satisfactory will send back the stuff and pay all charges.

JOY—I know! I know! I have sent to them for years. And they've got a very useful Vest Pocket Edition, giving pointers on testing and buying gold, that they mail to jewelers free.

When two Jewelers meet who have sent sweeps or old gold and silver to us, there can be no two differing opinions—they are TWO OF A KIND.

**GOLDSMITH BROS.,**  
**GOLD, SILVER AND PLATINUM REFINERS,**  
 63 and 65 WASHINGTON ST., CHICAGO, ILL.



his home, 335 Warren Ave., from a cancerous tumor in the cavity of the abdomen. Mr. Phillips is a native of Connecticut and is 54 years old. As a boy in 1852 he started in the jewelry business as salesman for Sherwood & Whatley on Lake St. and later was engaged with Ford & Edwards. Just previous to the civil war he opened a wholesale house in New York and at the close of the war returned to Chicago.

About this time in connection with Allen D. Vorce, he opened a jewelry store in Hastings, Minn. The loss of a boatload of pianos by the foundering of a vessel wound up the firm there. For a few years following this Mr. Phillips was general ticket agent for the Northwestern road. His next entrance to the jewelry business was as salesman for Clapp & Davies, Chicago, and on their failure he again entered business for himself at 67 Washington St., later moving to the Masonic Temple. The business is now conducted by his son, Luke Phillips, under the firm name of H. R. Phillips' Son, 601 Columbus building. Mr. Phillips has been unable to leave his home since July 17th.

**Kansas City.**

J. Russ Mercer is refitting his store with new fixtures.

The jewelry store of D. C. Minton, El Reno, Okla., has been closed under a chattel mortgage.

W. W. Whiteside, Liberty, Mo., and A. L. Meyers, Centralia, Kan., were in Kansas City a few days ago, buying goods.

J. Russ Mercer is preparing an elaborate window display for the Saturday before Easter. He is importing some rare orchids from the south to use as a back-ground for a display of jewels.

George W. Rose and S. W. Chase have moved their store from 14 W. 9th St., to B. W. Adams' drug store at the corner of 5th and Wyandotte Sts. Mrs. Rose has purchased a half interest in the drug store.

The stock of Geo. B. Bowers, jeweler, Lyndon, Kan., has been seized on a writ of attachment in favor of a wholesale house in St. Louis. The liabilities are not large, but are not covered by the assets.

J. W. Hile, formerly a jeweler in Kansas City, Kan., and Valley Falls, Kan., but now a lecturer and organizer for the American Protective Association, caused a riot at Dallas, Tex., by a lecture against the Catholic Church.

A dispatch from Fort Scott, Kan., says that an unknown jewelry vender, who had been selling jewelry in that city was run over and killed on the Kansas City, Fort Scott and Memphis tracks. The engineer saw the body on the tracks, but not in time to stop the train. There was nothing on the body by which the man's name could be learned.

The war between Eleazor Hart, of the Hart Jewelry Co., and Herman Streicher, of the Streicher Watch & Jewelry Co., has broken out anew. Last week Hart caused Streicher's arrest on the charge of criminally slandering him. Streicher was arraigned before Justice Hawthorne and gave bail to await a hearing. The action is based upon remarks Streicher is alleged to have made about Hart several months ago and for which slander Hart is now suing him for \$10,000 damages, as before told in THE CIRCULAR.

# JUST OUT!

Our New Illustrated Catalogue of . . . .

Watch Materials, Tools, & Jewelers' Supplies was issued MARCH 20th.

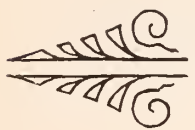

IF you have not already received a copy notify us and we will send you one at once. We wish to emphasize that our Prices will be found the LOWEST, quality of goods considered. With a well selected stock we are enabled to fill all orders promptly and correctly.

**BENJ. ALLEN & CO.,**

141-143 STATE STREET, CHICAGO, ILL.

Watches, Diamonds, Clocks and Jewelry.

## A SWINDLE!

The Watchmakers, Jewelers and Opticians throughout the United States and Canadas are cautioned to

**BEWARE**

of Cheap Carved Iron Watch and Spec. Signs, made in imitation of ours by UNSCRUPULOUS PARTIES in Chicago and New York, claiming to be "SUPERIOR" Metal Signs. They are cheap, hollow and brittle things, made of poor THIN ZINC. While they are a little cheaper in price than ours, they are fully 75 per cent. below in Style, Finish and Durability, and are PRACTICALLY WORTHLESS.

ALL of the GENUINE Carved Iron Watch Signs have "GROUT'S EXCELSIOR SIGNS," in SMALL BLACK LETTERS, close UNDER the HANDS on the DIALS, as shown in our illustrations, and also look for letter "G" on end of Spec. Signs. ANY OTHERS ARE FRAUDS.

**LOOK OUT FOR THEM**

AS WE WANT ALL WHO BUY IRON WATCH SIGNS PROTECTED,

Made only by the **EXCELSIOR SIGN & MFG. CO., CHICAGO,**

SEND FOR OUR ILLUSTRATED 64-PAGE CATALOGUE OF SIGNS & TOOLS, FREE.



**Minneapolis and St. Paul.**

The assignee's sale of the stock of B. B. Marshall & Son, Minneapolis, commenced March 12.

Louis Gans, with H. E. Murdock, Minneapolis, last week started on his regular western trip.

M. Albrecht, St. Paul, last week removed from 353 E. 7th St. to new and larger quarters at No. 225 same street.

S. H. Clausin, of S. H. Clausin & Co., Minneapolis, last week returned from his recent trip to the Pacific coast and reports trade fair.

I. R. Bunker, for the past seven years in the employ of Geo. R. Holmes, St. Paul, as watchmaker, has severed his connection with that firm.

The Dupont Jewelry Mfg. Co., Minneapolis, last week removed from 119 Central Ave. to No. 121 same street, and now occupy one of the finest stores on that thoroughfare.

Wm. H. Creveling, with the Reed & de Mars Jewelry Mfg. Co., Minneapolis, last week came in from his northern trip to replenish his stock and immediately started out again through Wisconsin.

Judge Russell is conducting an examination for the purpose of ascertaining what disposition has been made of the assets of the Donelson Jewelry Co., Minneapolis. The creditors claim that Donelson has made fraudulent disposition of the property, and they also ask for a division of the assets.

Lewis Finkelstein, St. Paul, has gone into the jobbing business at 84 E. 7th St. with a complete line of American cases and movements, besides a full line of chains, charms and lockets. J. W. Loewenberg, formerly manager for F. M. Sproehle & Co.'s branch store in St. Paul, will represent Mr. Finkelstein in the Twin Cities as city salesman.

**Louisville.**

The Bowden Bill, which will have the effect of either shutting out the cheap vendors

of jewelry and other merchandise, or of making them pay a much higher license, was passed by the Kentucky Legislature and Senate, and is now ready for the Governor's signature.

S. S. Lieberman left Saturday on a fishing trip at Crandel, Ind.

The Chicago Novelty Co., 2d and Jefferson Sts., are running an auction sale.

It is reported that S. R. Beisenthal has been robbed of a small amount by a Swiss watchmaker who skipped town. The watchmaker is said to have slipped things from the store as he left at night.

**Indianapolis.**

Jas. Turley, Angola, Ind., has moved into a new store room.

E. C. Miller and family have gone to Hot Springs, Ark., for a stay of several weeks.

L. Burgheim will shortly remove from 9 S. Illinois St., to a more commodious room on Washington St.

Denney Bros., Portland, Ind., will hereafter occupy their entire store room. It will be refitted and improved.

The E. Howard Watch & Clock Co. have recently put up a very handsome striking town clock on the Court House at La Porte, Ind.

T. C. Crane is laid up as the result of a painful accident. While trimming the shade trees in front of his residence he lost his footing and falling from a tree broke his ankle.

A motion to annul the indictment alleging conspiracy, against B. Williams, of Chicago, ex-president of the DuLaney Clock Co., Valparaiso, Ind., was sustained in the Porter Circuit Court at the latter place, March 15th.

A young man claiming Indianapolis as his home was arrested in Brazil, Ind., last week, on suspicion. Twenty pairs of fine gold spectacles and a quantity of jewelry were found on his person, about which he could give no satisfactory account.

**"Best" Eye Glasses.**



The "BEST" Guard embodies some new features of great value. The lower part is rigid, the upper part is flexible. Made in both shell and cork. Must be seen to be appreciated.

Sample Eyeglass Frame, in 10k. gold.	- -	\$2.90
" " " in Steel or Nickel.	-	.35
Sample Pair of 10k. Gold Guards.	-	.85
" " of Nickel Guards.	-	15

**Geneva Optical Company,**

69 WASHINGTON STREET,  
CHICAGO.

**CHAS. H. PFEIL,**

MANUFACTURING JEWELER.

Diamond Work a Specialty.

**BEST of Workmen.  
BEST Design Work.  
GUARANTEED Workmanship.**

Send a trial order and be convinced.  
**182 State St., Chicago.**

**HUGO MUELLER,**  
182 State St., (Room 70,) Chicago.

**FINE WATCH REPAIRING**

IN ALL ITS BRANCHES.

Work for the trade promptly executed by skilled workmen.

**PARSONS : SCHOOL**

—FOR—

**WATCHMAKERS,**

PEORIA, - - - ILL.

Send for Circular and Terms.

**PARSONS & CO.**

WATCH CASE MAKERS AND REPAIRERS.

**BOLSTAD MANUFACTURING  
AND PLATING CO.,**

GOLD AND SILVER PLATERS.

DESIGNING AND ENGRAVING.

170 Madison Street, - - CHICAGO.

**ELGIN HOROLOGICAL SCHOOL,**  
THOROUGHLY PRACTICAL.  
COMPETENT INSTRUCTORS.

Send for Prospectus.

**ELGIN, ILL.**

**PATENT FIBRE-FACED HAMMERS.**

5 oz. for Watchmakers.  
10 oz. for Manufacturing Jewelers.  
Price 50 Cents Each.

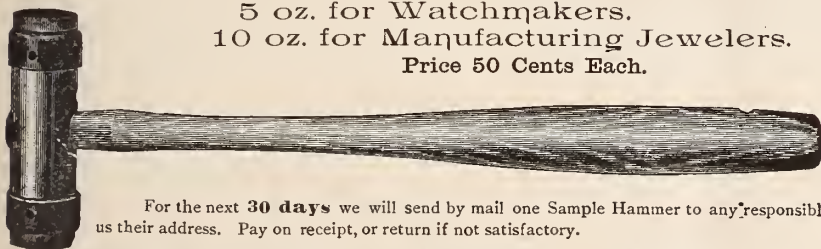

For the next 30 days we will send by mail one Sample Hammer to any responsible firm giving us their address. Pay on receipt, or return if not satisfactory.

**W. W. OLIVER, Sole Manufacturer, - Buffalo, N. Y.**

Send for our No. 10 Catalogue.

QUALITY IS THE STANDARD OF VALUE.

CHARGES TO SUIT THE TIMES.

When interested, write your jobber for new price list for 1894, or

**Moseley & Co., Elgin, Ill.**



One of the best of the very best.



No. 2 Moseley Wire Chuck has length, strength, accuracy.



**Cincinnati.**

H. E. Hickock, of the Waterbury Watch Co., is in Cincinnati this week.

Gus Frank made his initial trip on the road for D. Schroder & Co. last week.

Ike Pollock, Ashland, Ky., and Nathan Adler, Lexington, Ky., were buyers in Cincinnati last week.

Muehlmatt, Hedges & Co. are working on a watch case block which they will soon have on the market.

Homan & Co. have put in an elegant case in their sample rooms for the novelties they are producing this year.

Cliff Miller, formerly with Duhme & Co., is now engaged with H. Keck Mfg. Co., and will represent them on the road.

Louis Hummel is one of the incorporators of the Cedar Grove Mutual Aid Association, of Cincinnati, for the benefit of jewelers.

Frank Drake, Greensburg, Ind., is rejoicing in an heir, and Joseph Drake, its grandtather, is quoted as doing remarkably well.

Stern & Co. are represented on the road this Spring by Charles and Louis Rauch and C. B. Goldsmith. All are out doing fair business.

S. Bene, of Bene, Lindenberg & Co., is home from a five weeks' trip through the south. He reports sales equal to those of last Spring.

H. C. Thomas, Washington, Ind., came to Cincinnati last week to meet an importer of fine bric-à-brac. He will make an elegant Spring opening.

The Standard Optical Co have opened up in the Arcade. Charles A. Culbertson is the proprietor and John Cohn, formerly with Amberg & Co., is the manager.

H. B. Beckett, who has charge of the Cincinnati and Louisville trade of the Dennison Mfg. Co., has been kept busy the past eighteen days with Easter calls for standard goods in their lines.

O. E. Bell & Co. are making another snap offer to the trade in clocks. Their best Spring special is the case of clocks. They are aiming to have only one jeweler in each town to represent them exclusively.

**C. H. Knights & Co. Sue for 23 Diamonds or Their Value.**

DETROIT, Mich., March 16.—C. H. Knights & Co., Chicago, have commenced suit against C. A. Piella, jeweler, Lansing, Mich., for \$3,000 damages or the return of 23 diamonds sent to him last June on approval. As reported in THE CIRCULAR at the time, the gems were stolen from the store by crooks following Forepaugh's circus, soon after they were received.

The jeweler holds that he had not purchased the diamonds and was in no way responsible for their loss.

J. W. Martin has opened a business at 1021 Walnut St., Milwaukee, Wis. Mr. Martin has recently graduated from one of the leading horological schools of the country.

EST. 1870.



**DR. PETER HENRY,**  
SPECIALIST IN  
**WATCH • CASE • DISEASES**

Key Winders & changed to Stem Winders.

Hunting Cases: changed to O. F.

English Cases changed to fit American movements

Can be cured at  
**53**  
Longworth St.,  
Cincinnati, Ohio.

**Bell's Snaps for Cash Buyers.**



Three eight-day strike and three eight-day strike alarm, oak and walnut clocks, assorted, 22½ inches high, warranted, all 6 for \$11.38, net. Four inch nickel alarm clocks by the case, at 57c. each, net, warranted. Eight-day strike gong enamel clocks, 18 inch base, a "Beaut" at \$4.75 each, net.

14 kt. diamond point fountain pen, warranted, at 65c. each net.

All guaranteed in price and quality, illustrations sent on request. Watches and Jewelry at proportionate rates, write for selection packages. Secure agency and one year's advertising on best line of filled cases made, sold only to one Jeweler in a town.

Write us **O. E. BELL & CO.,**  
**THE BELL WATCH CASE CO.,**  
**CINCINNATI, OHIO.**

**Engravers' Type.**

A Rubber Type in new styles specially adapted to Engravers' use. Seven different sizes now ready.

*Minnie S. Foster*  
*Sir Walter Scott.*

Does away with all tracing. Letters are stamped upon the article in clear cut script or old English. The outline can readily be engraved by even the apprentice.

Type made on new principle, bevel edged; alignment guaranteed. Every Engraver should have it. Write for particulars.

**WM. H. DIETZ,**  
117 Dearborn Street, Chicago.



**GIBSON HOUSE,**  
CINCINNATI, OHIO.

ABSOLUTELY FIRST-CLASS AMERICAN PLAN HOTEL.  
\$3.00 PER DAY.

Extra Charge for Parlors and Rooms with Bath attached. The unequalled advantages in central location, liberal management, modern appointments, experienced service and perfect cuisine, have permanently established the Gibson House as The Most Popular First-Class Hotel in Cincinnati.

AMPLE VAULTS FOR THE PROTECTION OF VALUABLES.  
**THE GIBSON HOUSE CO.,**  
H. B. DUNBAR President and Manager

**DUEBER-HAMPDEN WATCHES.**

The most reliable watches are the Hampden 17 Jewel. A full line of Dueber Cases and Hampden Movements. Cash buyers write us.

**BRETHAUER WATCH & JEWELRY COMPANY,**  
SPECIAL AGENTS,  
71 WASHINGTON ST., CHICAGO, ILLS.

**THE PLANCHAMP & BECKER CO.**  
Makers and Repairers of  
**WATCH CASES,**  
Gold and Silver Plating —  
— of Watch Cases a Specialty.  
UNEXCELLED FACILITIES.  
63 and 65 East Washington St., Chicago.

WHEN IN CHICAGO, VISIT THE  
**Chicago Watchmakers' Institute,**

SUITE, 1521-1523 B MASONIC TEMPLE.

A Modern Trade School for the Watchmaker, Jeweler and Engraver. Write for New Catalogue.





**Detroit.**

L. Black & Co., New York, expect to have their wholesale stock there moved to Detroit by the middle of April. Mrs. A. Landsberg, wife of the senior member of the firm, returned from New York Friday.

Wolf & Co. is the name of a new jewelry firm at 41 Michigan Ave. The business was started last week and the goods will be sold at auction. G. W. Lusk and H. F. McConnell, of Chicago, are the auctioneers.

Nearly all the Woodward Ave. stores have stocks of seasonable novelties. Jobbers find that mail orders are better. George Corhart, Pontiac; Wm. Ambler, Northville, and Mr. Limpricht, Berne, were the Michigan country jewelers here last week.

P. J. Morrison entered the Detroit Optical Institute last week for a course of instruction. R. C. Wynn, Smith Falls, Ont., finished a course of instruction in the Detroit Optical Institute last week. He purchased goods here and is now traveling through Michigan.

**Pacific Coast Notes.**

Baker & Miller, Riverside, Cal., have removed their store into a room formerly occupied by Johnson's book business.

M. German, Los Angeles, Cal., is advertising that he is going out of the business and inducing buyers on the "imperative" sale basis.

D. T. Pritchard, Medford, Ore., announces that he is not giving his goods away, but is selling as "cheap as can be bought in Jacksonville."

Horatio O. Klutz has sued Charles James to recover \$1,500 damages for the unlawful conversion by the defendant to his own use of a quantity of jewelry claimed by the plaintiff.

**St. Joseph, Mo.**

A. J. Levin, diamond and jewelry broker, has he failed. Last Summer opened up a loan office at 421 Edmond St., under the name of R. F. Levin.

W. R. Tilley, for many years with the St. Joseph Jewelry Co., has opened a jewelry repairing shop under the style of W. R. Tilley & Co.

Louis Burnett & Co. have moved to 702, southeast corner 7th and Felix Sts. They have fixed up their store in an elegant manner, and have arranged an attractive optical parlor of which L. Burnett, a graduate optician, will take charge.

At a meeting of the directors of the Patent Silver Mfg. Co., Buffalo, N. Y. Frank M. Reynolds, of Rochester, N. Y., was elected secretary in place of P. W. Reynolds, resigned, who is now sick at St. Augustine, Fla. The company declared a dividend of 2 per cent. payable April 1, on their capital stock of \$250,000.

**REED & BARTON,**  
**SILVERSMITHS,**

MANUFACTURERS OF

STERLING *and* SILVER PLATED  
SILVER *and* WARE.

SALESROOMS:

**37 Union Square, New York.**

34-36 WASHINGTON STREET,

**Venetian Building, Chicago.**

FACTORIES, TAUNTON, MASS.

... THE ...

**American Horological Institute**

AND TECHNICAL SCHOOL OF LANCASTER, PA.,  
LATE OF PHILADELPHIA, PA.,

A Trade School where Watchmaking is taught practically. We do not manufacture

☼ BICYCLES OR DYNAMOS ☼

at this institute. We confine our work strictly to WATCH WORK and its kindred branches, which include

== Engraving, Jewelry Work and Optics ==

One tuition pays for all the branches. We do not have boy instructors at this institute, all men of years of experience. Each department has its separate instructor. Our institute is open for inspection. We kindly invite you to visit us and inspect our school modes of giving instruction and the progress that our students make by giving them practical instruction.

**THOMAS PENDERGAST,**  
PROPRIETOR AND MANAGER.

We have no competition for  
QUALITY.

**The Dale** is the BEST  
chuck on the  
earth to-day, at any price.

ALL KINDS, \$1.00.



MADE ONLY BY  
**HARDINGE BROS.,**  
1036 Lincoln Ave., CHICAGO, ILL.

**R. M. JOHNSON,**  
IMPORTER OF

**Diamonds AND Manufacturing Jeweler,**

67 WASHINGTON STREET,  
ROOMS 5 & 6,  
CHICAGO.

MASONIC EMBLEMS OF EVERY DESCRIPTION MADE TO ORDER.



## Queries by Circular Readers.

Editor of THE JEWELERS' CIRCULAR:

I have a large quantity of banca tin (Russian white metal) used for plating cheap articles. I had a recipe of the liquids used. There were three of them. The articles, knives, etc., were placed in one solution for a few minutes then quickly removed into the second solution; then inserted into the hot metal. The metal flowed well even on old rusty spoons, knives, etc., after which they were taken out of the metal and plunged into the third solution called the chill bath. I unfortunately burnt the recipes among a lot of old letters. Can you tell me what these liquids were. Kindly answer through your query columns. A. B.

ANSWER:—Correspondent forgot to state on what metal he wishes to deposit the tin. Besides this, and in view of the number of methods practiced in different shops, it is quite impossible for THE CIRCULAR to divine what special set of compositions he employed for tinning his articles. Since, however, he speaks of knives, it is presumable that he tinned principally iron, steel, etc.

*Tinning Iron.*—The surface of the iron is cleaned from scaly dirt, etc., by vitriol or sulphuric acid, and then scoured with sand.

It is next coated with a strong solution of chloride of zinc, and dipped into melted tin. The tin will instantly adhere to every spot that is clean. Or,

Cleanse the metal to be tinned, and rub with a coarse cloth, previously dipped in hydrochloric acid, and then rub on French putty with the same cloth. French putty is made by mixing tin filings with mercury.

*Tinning White Metal.*—For tinning white metal, use dilute solution of nitric acid 66° B. (1 part acid, 10 parts water); rinse in cold water. Then immerse the article in a solution of 2 parts zinc and 10 parts hydrochloric acid; withdraw and dip it quickly in the melted tin.

For copper use for second bath about 4 parts zinc to 10 parts hydrochloric acid. Although not stated at the commencement, it is self-evident that the article must be chemically clean, else the metal will strip.

This bath also serves for all alloys containing zinc, such as the different qualities of brass, etc.

## Trade Gossip.

G. W. Kennedy, who has just opened a large first-class diamond and jewelry establishment in Des Moines, Ia., has telegraphed to Excelsior Sign & Mfg. Co., 56 State St., Chicago, to forward at once a 24-inch Louis XIV. watch sign. "Let it be one of Grout's finest," he said.

F. M. Whiting & Co., North Attleboro, Mass., make a complete line of sterling silver hollow ware dishes, trays, fancy pieces, etc., in artistic patterns. In their announcement this week is shown a dainty piece in the Tyrolean pattern, one of the firm's latest designs which has already attained a wide popularity.

The earwire for diamond earrings manufactured by Watermann & Lehman, 37 Maiden Lane, New York, continues to meet with entire satisfaction wherever a trial is given; it absolutely prevents tipping in the ear and requires no explanation to the buyer. It is an article which needs no recommendation as it sells on its merits.

The Howard Sterling Co., Providence, R. I., have a real novelty in the shape of a sugar divider, intended for the special delight of those tea or coffee drinkers who want but "half a lump" or a "lump and a half." The divider, which is admirably contrived for the purpose will separate cleanly and deftly either cube or domino sugar, and cannot fail of appreciation.

The Sheldon building at John and Nassau Sts., New York, is especially adapted to the needs of the jewelry trade, which fact is being appreciated by many firms in the most tangible form, namely, by moving into it. Already the New York Jewelers' Board of Trade, Joseph Frankel's Sons, Stern Bros. & Co., E. Ira Richards & Co., and B. H. Davis & Co. have engaged quarters. The diamond trade will find that this building possesses many advantages. Anyone desiring offices will find the rents of the suites in this building compare favorably with those of other buildings in the neighborhood.

## Jeweler Kauffman Narrowly Escapes Death by a Jealous Husband.

PHILADELPHIA, Pa., March 16.—A profound sensation was created in the vicinity of 1911 Columbia Ave. last evening, over the attempted murder by Henry J. Farrell of his wife, and of Julius F. Kauffman, the Chestnut St. jeweler, who is a boarder in the house together with his two daughters. Jealousy was the cause, but Farrell is clearly demented and subject to hallucinations. No one believes in his accusations concerning his wife and Kauffman.

At the supper table last night Farrell pulled out a pistol and fired at his wife, the bullet lodging in her eye. Another bullet took effect in Kauffman's arm, inflicting a slight wound. Farrell then went to the Jefferson St. police station and gave himself up, and this morning he was committed without bail to await the result of his wife's injuries.

# GOOD TIMES ARE COMING.

Enliven your stock and set the ball rolling by putting in a line of the new "CHARMILLES" watch.

HIGHEST ART,  
GREATEST VALUE,  
LEAST MONEY.

FOR PARTICULARS AND PRICES ADDRESS YOUR JOBBER.

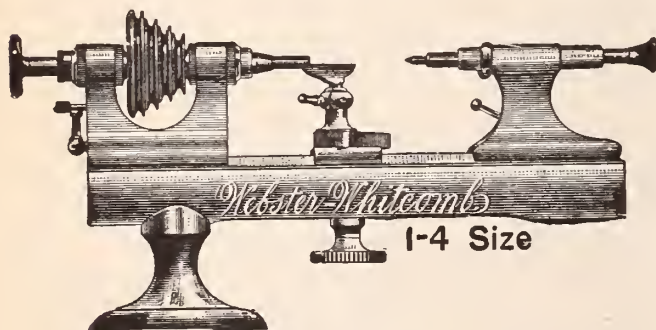

STRONGEST GUARANTEES.

Quality  
Maintained.  
Prices to  
Suit the Times.

Ask for our New  
Prices and  
Terms for 1894.

# American Watch Tool Company,

Chymistry Dist., Waltham, Mass., Stoney Batter Works.



**A Petition for a Receiver for F. G. Smith, Sons & Co.**

DETROIT, Mich., March 15.—Robert R. Howard, trustee of the mortgage given by F. G. Smith, Sons & Co., has filed a bill for a foreclosure on the stock and asks Judge Husmer to appoint a receiver to look after the business in the interests of the creditors.

On Nov. 21st the firm filed a chattel mortgage of \$74,500 in favor of Mr. Howard as trustee for certain creditors. Nearly all were Detroit and Pontiac banks from whom the firm had borrowed money. It covered their entire stock and secured outstanding commercial paper, consisting of 25 promissory notes, aggregating \$72,000 and \$2,500 for back rent. Mr. Howard, in the bill, states that all of the indebtedness but \$35,000 has been paid. According to the terms of the mortgage, the stock was to be sold in case the indebtedness was not paid as it became due. The trustee has taken no action toward the sale of the stock, and awaits the action of the court in the matter. He petitions for an injunction restraining that firm from selling the stock or collecting any accounts due. The date for the hearing has not been set.

A suit for \$10,000 damages was commenced against F. G. Smith, Sons & Co., last week by Bowen, Douglass & Whiting, of Detroit, attorneys for several eastern creditors. Garnishee proceedings for \$5,761.80 was the basis of the suit. The damages were placed at double the amount of the indebtedness. The case was suppressed and access to the papers was refused to THE CIRCULAR correspondent.

Mr. Whiting told THE CIRCULAR correspondent that the above move cut off all chances for an adjustment of the affairs of the firm and that it was also the reason why the trustee began foreclosure proceedings. In regard to the suppression of the suit he said it was to give Mr. Smith an opportunity to pay his claim without the usual publicity. Several cases have been suppressed in the same way.

F. G. Smith, Sons & Co. did a very large business during the holidays and it was thought that they might pull through and continue business under the present management. Expenses were reduced by cutting the wages of employes 20 per cent., and in discharging one or two high salaried salesmen. The firm recently made an offer of settlement to unsecured creditors which was accepted by a small number. They offered 50 cents on the dollar to all those having accounts under \$300. The rest were to wait two years without security or interest, and receive 100 cents on the dollar.

DETROIT, Mich., March 17.—George Krentz and Julius A. Lebkuecher, of Krentz & Co., commenced suit to-day to recover \$1,070 on a note for that amount given by F. G. Smith, Sons & Co., Aug. 19, 1893. It was made payable at the American Exchange National Bank of Detroit. Their attorney is J. G. Dickinson of this city.

# THE BOWDEN SEAMLESS RING

IS MADE ONLY BY

## J. B. BOWDEN & Co.,

Makers of Finger Rings of every Description.

COR. BROADWAY & JOHN STREET,

NEW YORK.



355 Mulberry Street.

Newark, N. J.

THOMAS W. LIND, Manufacturer of Jewelers' Findings,

67 FRIENDSHIP STREET, PROVIDENCE, R. I.



FULL SIZE NEW ROCOCO.



*Settings Made in Any Desired Thickness of Stock.*

Call or send for samples of my New ROCOCO PATTERNS, for Picture Frames, Cane Heads, Whips, Boxes, Napkin Rings, etc.

Large Assortment of TRIMMINGS for Millinery Ornaments, Scarf Pins, etc



**DIAMONDS.****Wm. S. Hedges & Co.,**

Importers of Diamonds,

And Manufacturers of DIAMOND JEWELRY.

170 Broadway, New York.

22 Holborn Viaduct, London.

**R. A. KIPLING,**

Importer of

**PRECIOUS STONES,**

21 &amp; 23 Maiden Lane,

19, RUE DROUOT,  
PARIS.

New York.

NEW I IMPROVED NEW I

Adjustable "Eclipse" Eye Glasses.

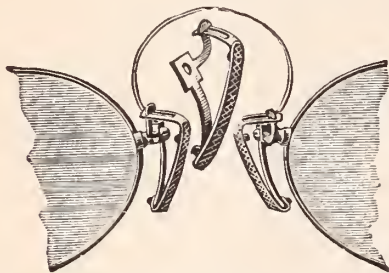

PATENT APPLIED FOR.

We claim this invention to be the only one which combines the advantages of both the adjustable and offset guards. We will furnish these frames or guards in either Zylonite or Cork.

WRITE FOR CIRCULAR.

**JOHN SCHEIDIG & CO., SOLE AGENTS**  
 43 MAIDEN LANE, NEW YORK.

DON'T FORGET THE JEWELERS' CIRCULAR PUBLISHING CO.'S BOOK LIST when in want of any technical book in the Jewelry or Kindred Trades.

**Alfred H. Smith & Co.,**IMPORTERS**DIAMONDS**

AND

PRECIOUS STONES,

182 BROADWAY, COR. JOHN STREET,

NEW YORK.

38 Holborn Viaduct, London, E. C.

**NEW CLOCK STAFF WRENCH.**

This entirely new and most useful tool is for setting up clocks, particularly fine and costly ones. Can remove pivots at ease. No chance of displacing other pivots in the operation. For description, send 5c. in stamps for catalogue of over one thousand varieties of fine tools.

O. W. BULLOCK &amp; CO., Springfield, Mass.

**Fashions in Jewelry and Silver-ware.**

A LADY'S RAMBLES AMONG THE JEWELERS.

Silver fillets are in demand to be worn with light filmy draperies.

Biblical stones are coming into fashion. In these are the jacinth, peridot and amethyst.

The flower brooches of white enamel with gold encrusted edges renew their attractiveness.

A new hair ornament is an amber shell waving stick with a heavy repoussé silver crook for a head.

Mercury wings from a diamond band is still the latest head-dress. One may however question the taste.

There are a number of new and pretty silvers shown. These have highly polished surfaces and heavy broken edges.

The patent corkscrews made of repoussé silver are pretty enough to hang to a chate-laine, except for the moral effect.

A new bangle is of the Greek key pattern studded with pearls and turquoises or with diamonds and sapphires, rubies and pearls.

Bean jewelry, for what reason one wonders, is regarded as lucky. Every dupe desires to possess bean cuff buttons in a pod shaped case.

The seamless waists require a belt of ribbon or metal. A dress was seen with a silver belt from which hung three little ornaments in front.

The jeweled circles that are used as brooches are very pretty. One of sapphires with small jewels set in the corners, was especially beautiful.

A new letter rack of silver has a number of slanting closely set racks. This is more convenient than the large racks which do not admit of assortment.

The jeweled wreaths that are used as brooches are prettier than almost any other brooches that have appeared in several seasons. Nor are they without sentiment.

The use of buckles and cabochons of jet and semi-precious stones of chrysoprase are used largely in dressmaking. Some gowns are fairly plastered with paste buckles.

Large buttons are to be worn and offer opportunities for some handsome things of this sort in stones, jet, steel and cameos. Such buttons when the fashion is past, are put away until the fashion returns, as inevitably it does.

An artistic way of setting pearls is between rings of silver encrusted with small diamonds. A necklace was seen of medium pearls set two together between rings of this sort. In front three pearls set as tre-foils with a diamond at the head and tiny diamonds in the interstices depend from between the pearls. The necklace has a sort of moonlight effect that is delightful.

ELSIE BEE.

**OPPENHEIMER BROS. & VEITH,**

WATCHES AND

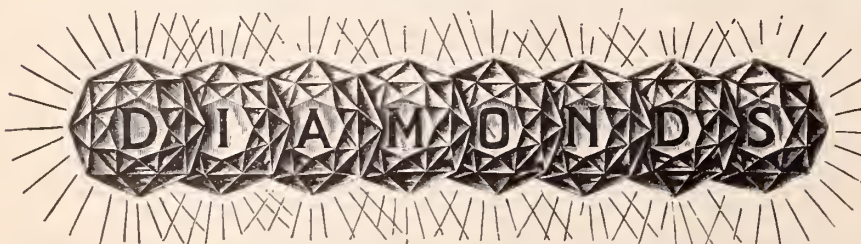
**DUEBER CASES. HAMPDEN MOVEMENTS.**

AMSTERDAM, HOLLAND, 2 TULPSTRAAT.

LONDON, ENG., 28 HOLBORN VIADUCT.

NEW YORK, 35 MAIDEN LANE.



**Correspondence.**

ONE FIRM THAT PRACTICE WHAT THEY  
PREACH.

BROWNSVILLE, Or., March 8, 1894.

Editor of THE JEWELERS' CIRCULAR :

As you have, through the columns of THE JEWELERS' CIRCULAR, always espoused the protective side of the situation, in a business point of view, as regards the rights of the legitimate retail jeweler and upheld to the best of your ability a system of honorable dealing, I take the liberty of drawing your attention to the following transaction, which speaks loudly for itself and needs no comment other than the only conclusion that can be arrived at, namely, "Honor to whom honor is due." During the past week there was forwarded by an individual, *not in the jewelry business*, a package of job work to Messrs. Otto Young & Co., of Chicago. I to-day received a letter from the firm which I enclose for publication, showing most conclusively that the gentlemen "practice what they preach" and protect the legitimate jeweler in the legitimate jewelry business.

Most respectfully yours,

THOS. PILLSBURY.

CHICAGO, March 1, 1894.

T. S. Pillsbury, Brownsville, Ore.

DEAR SIR:—We are in receipt of some job work from F. M. Jack, of your place. In reply say, that we defer attending to same and have referred Mr Jack to you, to have work done through you, as we confine our business to the watchmaker and jewelry trade exclusively

Yours truly,

OTTO YOUNG & Co.,

Per K.

**Points of Law.**

FRAUDULENT CONVEYANCE.

Direct proof of fraud can seldom be obtained, nor is such evidence absolutely essential to establish the fraudulent purpose of the parties to a pretended transfer of property, but such fraudulent purpose may be shown by the conduct of the parties, the details of the transaction, and all the surrounding circumstances.

*Sonnenschein v. Bartels, Supreme Court of Neb.*

AUCTION FOR PRICE OF SALE BY HUSBAND.

Where a husband with the knowledge and consent of his wife, makes a single sale of a personalty, some of which belongs to him, some to her, and some to them both jointly, he can sue for the price without joining her as plaintiff.

*Gillett v. Knowles, Supreme Court of Mich.*

NO RIGHT TO VENDOR'S LIEN.

A married woman who transfers her property to her husband merely for the purpose of enabling him to raise money thereon for his business has no vendor's lien.

*Reynolds v. City Nat. Bank of Watertown, Supreme Court of N. Y.*

ESTABLISHED 50 YEARS.

RANDEL, BAREMORE & BILLINGS,

IMPORTERS OF

DIAMONDS,

AND OTHER PRECIOUS STONES.

FINE PEARLS A SPECIALTY.

MANUFACTURERS OF

DIAMOND JEWELRY,

IN THE LATEST DESIGNS.

Diamonds Recut in Modern Styles or Repaired on Premises.

58 Nassau Street,  
29 Maiden Lane  
NEW YORK.

1 Tulp Straat,  
AMSTERDAM.

1 St. Andrews St.,  
Holborn Circus,  
LONDON, E. C.

ESTABLISHED 1841.



TRADE MARK.

CARTER, SLOAN & CO.,

MANUFACTURERS OF GOLD JEWELRY,

No 15 MAIDEN LANE.

NEW YORK.

A. CARTER, JR.  
A. K. SLOAN.  
C. E. HASTINGS.

GEO. R. HOWE.  
WM. T. CARTER.  
WM. T. GOUGH.

FACTORY, NEWARK, N. J.



JOHN N. DISSELKOEN,

Cutter and Importer of

DIAMONDS

FACTORY.  
76 LANGEBLEEKERSPAD  
AMSTERDAM.

19 East 16th St.,  
NEW YORK.

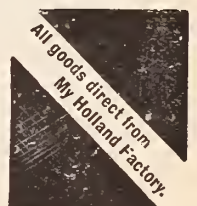



**HENRY ABBOTT,**

MANUFACTURER OF

Stem-Winding Attachments  
FOR WATCHES,

No. 2 Maiden Lane, NEW YORK.

**G. A. WEBSTER**

42 &amp; 44 Madison St., Chicago, Ill.

**Manufacturer,**

AND WESTERN AGENT FOR

E. G. WEBSTER &amp; SON, of Brooklyn, N. Y.

A. F. TOWLE &amp; SON CO., of Greenfield, Mass.



61 Hanover Street, Boston, Mass.

Sales made for Jewelers only in their established places of business. Can give best references of any auctioneers in America.

All communications strictly confidential.

PATENT paneled METAL

**CEILING**

Stamped Raised Panels.

ARTISTIC AND PERMANENT.

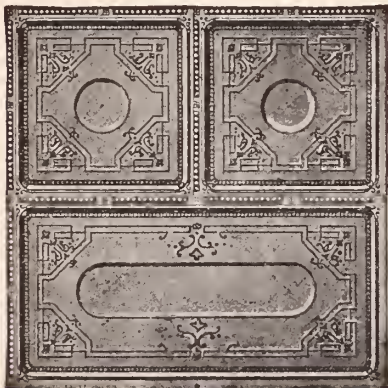

Easily applied in new buildings, and over old broken plaster or wood Ceilings. If interested in building or repairing, send stamp for Illustrated Catalogue, and state if CHURCH, HALL, STORE, OFFICE, or SCHOOL Ceiling is wanted. Address

A. NORTHROP &amp; CO., Pittsburg, Pa.

**Communion Plate.**

BY J. H. BUCK.

**B**EFORE considering the best materials and forms for the present time, it will be interesting to trace the development of the vessels used in the administration of the Lord's Supper, more particularly with reference to communion cups. These have been made of various materials in different ages of the Christian Church—gold, silver, brass, tin, pewter, wood, stone, glass, and in many canons and councils one sort would be ordered and another proscribed. Gold and silver vessels were probably in use from the earliest Christian times, and wood and stone were most likely used in the poorer churches. In form these chalices were large and generally provided with side handles for the convenience of lifting—the wine being sucked through a long, narrow pipe or hollow reed, made of gold, silver or ivory, which was often, though not always, fastened on a pivot to the inside of the vessel, which was kept in the hands of the priest. The mediæval, or pre-Reformation chalices were without handles, consisting of three parts—the cup or bowl, the stem, which in its middle swelled into a bulb called the knop, and the foot. At the Reformation chalices were ordered to be “altered to decent cups,” or to “a comely communion cup with a cover.” Of these cups, commonly known as “Queen Elizabeth's cups,” there are numbers still to be found in the English churches; the bowl, stem and foot remained, but the knop was either entirely left out or was small; the foot was invariably round.

From the time of the Restoration cups were made of great size, with straight sides turned out towards the top to form a lip, and mounted on a plain circular stem and foot; some still had the cover patent, but at the end of the 17th century a plain circular salver on a conical foot, and later a plain plate were in use. To this period belongs the service in use at Hyattsville Church, Md., made in London in 1707. This service at one time belonged to the old church at Patuxent, or Upper Marlboro. It was probably presented by Col. Ninian Beall, who gave the ground upon which the church stood. He was one of the earliest Presbyterian elders in the country, his name occurring in the colonial records as early as January, 1667. The plates have long since disappeared.

In Scotland the shapes of the communion cups never followed the English usage, and although “Queen Elizabeth's cup” had spread through the length and breadth of England, not a single Scotch cup of that type has been found. They were of a very peculiar shape, the bowls were broad and shallow, resembling the tazza. From Sime's History of St. Culbert's we learn that “In January, 1618, it was proposed to have new cups and plates for the communion service. ‘The Session’ say the minutes, ‘thocht it maist meit that thair befouir cups of silver

to serve at the tabill, twa bassings of coin with ane laver; and the barrones, gentlemen, heritors and fewars to pay four hundredth marks, and the town of Edinburgh, suburbs, etc., to pay two hundredth marks’ to defray all expense. In the year following these cups were produced before the Session. They were beautifully chased, the stalk being six inches in height, but the cup itself was only about two inches deep and eight inches across. On the bottom was engraved the following sentence: ‘I will tak the covp of salvatione, and call upon the name of the Lord, 116 Psalm, 1619,’ and around the rim of the cup these words, ‘For the Vast Kirk ovtwith Edinbvrgh.’ New cups of a modern form were placed on the original stalks only a few years ago.”

Those belonging to Newbattle church are interesting specimens. This open-mouthed type was developed into various beautiful forms, and remained in favor for a century. Gradually the bowls became narrower and deeper, developing into the large and useful shape so common in the eighteenth century. The plates for the bread were large, circular, and with little or no ornament. Flagons took the place of the phials or cruets of earlier days at the beginning of the seventeenth century—the pear or jug shape giving place to the tankard pattern, as in the Hyattsville example. Besides the flagons for holding wine, there were smaller flagons or ewers, used for the baptismal water. Ewers and basins devoted to this service are common—that of the Tron church being seventeen inches in diameter, with this inscription, “He that Believeth and is Baptized shall be Saved.” Alms dishes and basins exist in considerable numbers.

This sketch would not be complete without some reference to Communion Tokens, the use of which has almost died out. Mr. Thomas Warner, in his pamphlet, states that “Nearly all of the early churches planted in America, which sprang directly from the Presbyterian body as constituted in Scotland and the North of Ireland, used the ‘Token’ in celebrating the Sacrament of the Holy Communion.” The Liturgy of the Church of Scotland (c. 1638) orders: “So many as intend to be partakers of the Holy Communion shall receive these Tokens from the minister the night before.” This excluded all unworthy persons and impostors from the sacrament. These Tokens were of lead or pewter; brass and nickel are sometimes found.—*The Evangelist.*

THE JEWELERS' CIRCULAR, the largest and handsomest trade journal in the United States, celebrated its twenty-fifth anniversary, February, 1894, by issuing a double number with an illuminated cover with silver shield and lettering. In other respects it is a number to keep, for it contains the history of the Tiffany and other great jewelry houses in the United States, and much other matter of interest.—*The New Cycle* (edited by Jennie June).



**Philadelphia.**

C. S. Davis spent several days on business in New York, last week.

William Williams, of L. A. Scherr & Co., has returned from a visit to the interior of the State.

Walter Davis, of H. Muhr's Sons, has started on a four weeks' trip through Pennsylvania and West Virginia.

In the Supreme Court on Monday the injunction case of the Pairpoint Mfg. Co., *et al.*, vs. the Philadelphia Optical & Watch Co. *et al.* Keystone Watch Case Co., appellant, was argued.

The drawing for the horse presented by George W. Scherr to the Jewelers' Relief Fund, New York, has been postponed from March 31 until April 7. The drawing will take place at the Jewelers' Exchange, New York, between 4 and 6 P. M., on that date.

Vincent Delales was arrested in Wilmington, Del., on Thursday by detectives of this city, on the charge of fraudulently appropriating co-partnership property. The allegations are that on Dec. 18, 1893, the accused with Carmine Vitali established a jewelry store on South St., between 3d and 4th, Vitali subscribing \$160. Delales, it is said, appropriated the receipts in the store, and on Dec. 28, sold out the store and fixtures and left for Wilmington with the proceeds. He was brought here on Friday, and committed for trial.

**New Bedford, Mass.**

Wm. L. Kelley, the Purchase St. jeweler, has the sympathy of a wide circle of friends in his sad bereavement in the death of his wife.

George H. Griffen, Portland, Me., formerly a clerk for C. W. Haskins, of this city, has purchased the stock and fixtures from H. S. Francis, who recently purchased them of Mr. Haskins. Mr. Griffen will also conduct his store in Portland.

At the annual meeting of the Pairpoint Mfg. Co., March 6, the following officers were elected: Directors, Edward D. Mandell, Morgan Rotch, William Baylies, William Lewis, Antone L. Sylvia, Clarence A. Cook, Thomas A. Tripp; clerk and treasurer, Thomas A. Tripp.

**Syracuse, N. Y.**

H. C. Watts, optician for Calvin S. Ball, returned Tuesday last from a week's vacation.

C. E. Eager has been indulging in a Spring house cleaning, painting, papering, etc. Blue and white are the prevailing color scheme and the effect is quite attractive.

Among the out-of-town buyers noticed in Syracuse during the past week were: M. J. O'Hara, Camillus; Jesse Clark, East Syracuse; Bert Waterbury, Brewerton; C. C. Taylor, Savannah; Frank Lee, Memphis; J. F. Horton, Canastota and George Barney, Fayetteville.

The little daughter of Chas. L. Becker, of Becker & Lathrop, died on Sunday morning last after a long struggle with typhoid fever and bronchitis. Little Edna was six years old and a child of unusual beauty, and much sympathy is felt for the bereaved parents.

**Springfield, Mass**

L. S. Stowe has been awarded the contract for making the class pins for the High school class of '95. The emblem will have an Ionic base and Corinthian column.

Dennis F. Leary, who was compelled to move his jewelry store on account of the sale of his former location to the Young Men's Christian Association, and who purchased one of the Monitor stores close by is comfortably settled in his new place of business, which is a very cosy and convenient store. It is probable that Mr. Leary will erect a handsome block on his lot in the near future.

The jewelry trade was fairly well represented in Springfield during the past week. Among those who called were; A. N. Dorchester, Kent & Stanley Co.; L. G. Call, Simpson, Hall, Miller & Co.; Herbert E. Slater, Champenois & Co.; William H. Jones, Larter, Elcox & Co.; R. T. Supple, W. B. Durgin, M. Herzog, Peckham Seamless Ring Mfg. Co.; Herbert C. Barker, John W. Reddall & Co.; Mr. McCarter, Gorham Mfg. Co.; and E. H. Eckfeldt, Wm. B. Kerr & Co.

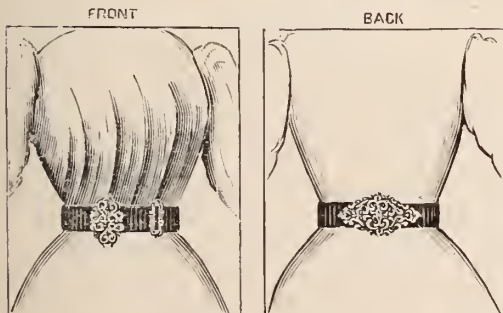
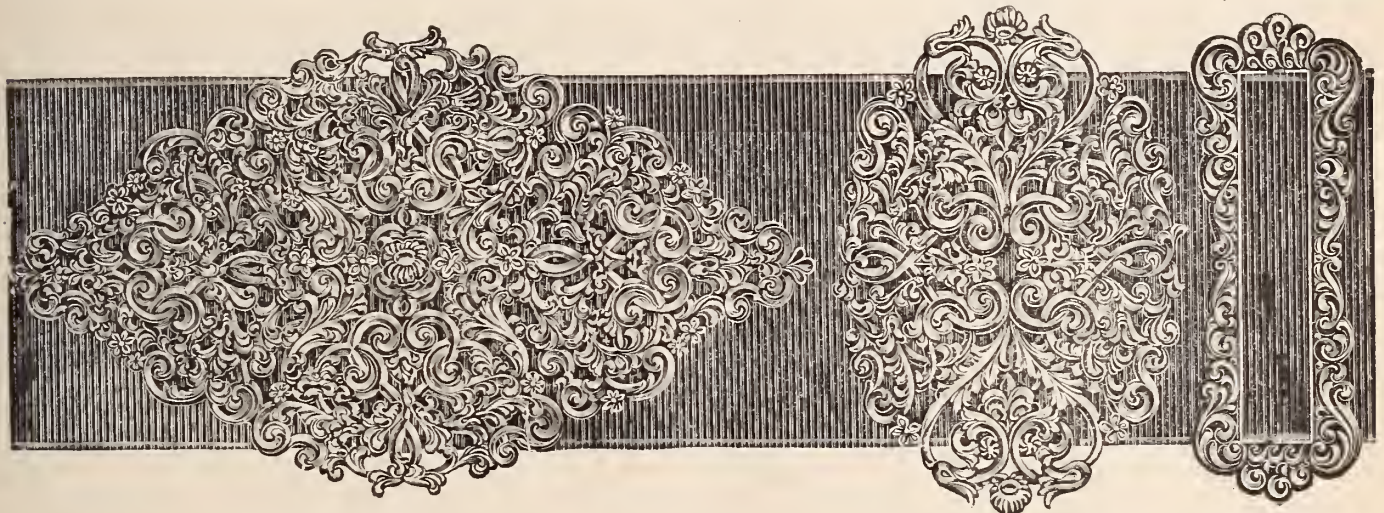

**The "Duchess" Belt.**

Something entirely new and original in STERLING SILVER BELTS, which includes buckles both front and back, as illustrated. We make also a large variety of the regular line of

BELTS, HAIR PINS, HAT PINS, CORSAGE PINS, GARTERS, SUSPENDERS, PAPER CUTTERS,

BAG TAGS, CONTINENTALS (or Collar Buckles) Etc., at marketable prices.

**Reeves & Sillocks, = 19 MAIDEN LANE, NEW YORK.**





Traveling representatives may consider these columns open for the publication of any news or items of interest regarding themselves or their conferees.

**W.** A. ELLIOTT, representing the Adelphi Silver Plate Co., New York, is finding good business in New England and in New York and Pennsylvania.

Z. H. Oppenheimer, of the American Watch Case Co., 11 John St., New York, visited Philadelphia last week.

George Tinker, representing Wm. B. Durgin, Concord, N. H., spent the past week in Chicago, whence he returned east.

Mrs. E. J. Fletcher, of the Fletcher Mfg. Co., manufacturers of patent case fixtures, has returned from a successful eastern trip.

C. F. Livermore, of the Middletown Plate Co., and George S. Pollitz, Rice & Hochster, are among the traveling men who will visit Kansas City this week.

The following traveling salesmen were in Kansas City last week: H. C. McConnell, C. G. Alford & Co.; E. A. Reed, Reed & Barton; W. J. Carrow, Mandeville, Carrow & Crane; S. E. Bolles, M. B. Bryant & Co.; W. Royal Berth, Gorham Mfg. Co.

Traveling men who called on Davenport, Ia., dealers the past week were: I. S. Richter, Bruhl Bros. & Co.; S. W. Frohlichstein, Henry Froehlich & Co.; C. S. Shepard, C. G. Alford & Co.; D. R. Smith, Merker Pocket Book Co.; Max Noel, Stein & Ellbogen Co.; C. P. Hoffmann, J. J. Sommer & Co.

Eastern jobbers and manufacturers represented in the Twin Cities the past week were: R. A. Breidenbach, by Robert Noel; Arnold & Steere, by Mr. Richmond; I. B. Miller Jewelry Co., by Mr. I. B. Miller; Kent & Stanley Co., by M. C. Fish; O. W. Bullock & Co., by Mr. Watson; Wadsworth Watch Case Co., by M. Loeb.

Among the traveling salesmen in Philadelphia the past week were: Thos. Rogers, Hayes Bros.; Frank Woods, Carter, Sloan & Co.; E. Ford, Baldwin, Ford & Co.; L. Morss, R. Blackinton & Co.; M. Baum, Rothschild Bros.; E. A. Karelson, M. D. Rothschild; Charles Gallagher, Enos Richardson & Co., and L. Bloch, Bloch & Bergfels.

Indianapolis trade received calls last week from the following salesmen: A. Marshuetz, Spencer Optical Mfg. Co.; E. A. Crawford, T. I. Smith & Co.; Ernest Block, W. & S. Blackinton; I. S. Richter, Bruhl Bros. & Co.; V. S. Burgesser, Krementz & Co.; Mr. Weiss, H. E. Oppenheimer & Co.; A. W. Wagner, Leon J. Glaenger & Co.;

Geo. T. Handbridge, Walter S. Berg; Arthur Reagen, L. H. Keller & Co.

The following traveling salesmen passed through Detroit last week: Mr. Pickering, Shoemaker, Pickering & Co.; Matthias Stratton, Jno. W. Reddall & Co.; Thomas B. Davis, Middletown Plate Co.; W. H. Allardyce, Ed. Todd & Co.; William D. Elcox, Larter, Elcox & Co.; Mr. Smith, Smith & Knapp; Max Arnstein, Arnstein Bros. & Co.; S. Levy, S. Levy & Co.; Mr. Harris, Ansonia Clock Co.

The following concerning the doings of Detroit traveling salesmen, will be of interest: Henry Anthony has returned from a four weeks' trip through Michigan for L. Black & Co.; he found the optical business quiet; H. L. Lowe, representing Kennedy & Koester, is in northern Michigan; C. M. Scammel, with the Johnston Optical Co., will return from a Michigan trip this week, and will then start for a six weeks' journey through Pennsylvania and eastern States; Arnold & Steere, who recently took possession of F. S. Ring's wholesale stock at 68 Woodward Ave., have put Thomas B. Delaney on the road.

Among the traveling men noticed in Syracuse, N. Y., the past week were: Geo. W. Mindil, American Watch Case Co.; James Panton, Mabie, Todd & Bard; J. Goldberg; L. E. Van Horn, Philipp Zellenka & Son; Leopold Laubheim, Adolph Goldsmith & Son; Mr. Pettit, Hayden Mfg. Co.; C. F. Goodwin, The Wm. Rogers Mfg. Co.; Otto H. Wolff, Bippart & Co.; W. H. Tarlton, Wightman & Hough Co.; L. H. Bosworth, Potter & Buffinton; John Shepherd, Keystone Watch Case Co.; Mr. Miller, Seth Thomas Clock Co.; Mr. Freedman, Bachrach & Freedman; Louis Fay, Kirby, Mowry & Co.; Fred Clarkson, Snow & Westcott; Mr. Williams, for G. Armeny.

Eastern travelers in Chicago last week included: C. F. Willemin, H. Muhr's Sons; Wm. A. Wightman, R. F. Simmons & Co.; Wm. W. Middlebrook, B. A. Ballou & Co.; E. L. Mumford, Waite, Thresher Co.; A. Peabody; Mr. Baldwin, Baldwin, Ford & Co.; Everett Rogers, Parks Bros. & Rogers; Baron Kennion, H. D. Merritt & Co.; F. C. Somes, Marsh & Bigney; Wm. H. Morris, J. W. Richardson & Co.; L. B. Elliott, Bausch & Lomb Optical Co.; E. H. Fordham, P. & A. Linton; Wm. D. Elcox, Larter, Elcox & Co.; N. D. Prentiss, Alling & Co.; Richard Robinson, Richard Robinson & Co.; C. C. Darling, L. W. Pierce & Co.; G. C. Booth, Hutchison & Huestis; Mr. Whiting, S. E. Fisher & Co.; A. Kaufman, Bruhl Bros. & Co.; Wm. Tappan; Austin Granbery; L. E. Bates.

Traveling men in Pittsburgh, Pa., last week were: A. Kaufmann, Bruhl Bros. & Co.; Jos. Beach, Wilcox Silver Plate Co.; Harry Osborne, Whiting Mfg. Co.; Mr. Dorchester, Brown & Dorchester; Mr. Barbour, Barbour Silver Co.; Mr. Bloch, W. & S. Blackinton; Cliff Booth, Hutchison & Huestis; Mr. Jorolemon, A. Jorolemon & Co.; Mr. Foster, Unger Bros., Col. Moore,

Dueber Watch Case Mfg. Co.; W. W. Stewart, Mabie, Todd & Bard; L. Schwab, New Haven Clock Co.; Ben Shiers, A. Pinover & Co.; Geo. Nelson Fena, C. Sydney Smith; F. H. Carpenter, Alfred H. Smith & Co.; S. Sickles, M. Sickles & Sons; A. N. Kline, Ezra F. Bowman & Co.; Mr. Gregory, Strobel & Crane; M. Stein, Wendell Mfg. Co.; Wm. W. Middlebrook, B. A. Ballou & Co.; Mr. Baldwin, Baldwin, Ford & Co.; and Louis Hirsch, Lissauer & Co.

Traveling men in Boston last week included: Missionary Edward Skinner, for the Elgin Co.; A. Barker, Meriden Britannia Co.; T. B. Wilcox, Pairpoint Mfg. Co.; C. C. Munn, C. Rogers & Bros.; Mr. Wade, Wade, Davis & Co.; Irving Smith, Crescent Watch Case Co.; Mr. Miller, Seth Thomas Clock Co.; Fred Miller, Shoemaker, Pickering & Co.; David Townsend, E. Aug. Neresheimer & Co.; E. Eckfeldt, Wm. B. Kerr & Co.; John Welch, Geo. O. Street & Sons; E. Simons, Simons, Bro. & Co.; Mr. Barker, John W. Reddall & Co.; Charles Kent, Wm. H. Ball & Co.; A. Rutherford, Kirby, Mowry & Co.; Mr. Kaas, A. J. Hedges & Co.; Charles Power, Ludeke & Power; Ed. Ackley, Unger Bros.; George Paine, E. I. Franklin & Co.; Benjamin Schloss, A. Wallach & Co.; Samuel L. Howland, Eisenmann Bros.; Henry G. Thresher, Waite, Thresher Co.; Charles B. Hancock, Hancock, Becker & Co.; Leverett S. Lewis, Randel, Baremore & Billings.

F. M. Whiting & Co., No. Attleboro, Mass., will mail on application their artistic booklet showing 22 of their best tea spoon patterns and 36 of their most popular coffee spoon patterns. Do not fail to send for it. Attention is also called to the firm's very complete and artistic line of hollow ware, fancy pieces and novelties.

## WATCH CASES REPLATED.

**T. F. TUTTLE & CO.**

Practical Gold and Silver Platers for the Trade.

Silverware Repaired, Replated and Cleaned,

418 Washington St.,

Boston, Mass.

## SEEING



is believing, and to see the product of our Optical prescription department, will lead you to believe that your popularity as an Optician will increase if we fill your orders.

**QUEEN & CO.,**

MANUFACTURING OPTICIANS,

1010 Chestnut Street, Philadelphia.



**News Gleanings.**

Fred. O. Pecht has succeeded Pecht Bros., Lewistown, Pa.

H. C. Korfhage, Racine, Wis., has made an assignment.

George Vincent will open a jewelry store in Waukesha, Wis.

Banton Bros. are going out of business at Cripple Creek, Col.

Mint Van Loan will open a jewelry store in Grand Meadow, Minn.

Fred Walker will embark in the jewelry business in Spencer, Mass.

G. P. Balch, Lynn, Mass., has given a chattel mortgage for \$1,163.

C. F. Lewis & Co., Fairmont, Minn., has assigned to Jay H. C. Sharpe.

C. M. Tuttle, Thomasville, Ga., has given a chattel mortgage for \$3,500.

The stock of Geo. Freund, Durango, Col., has been sold by the assignee.

H. W. Deans, Woburn, Mass., has filed a voluntary petition in insolvency.

Geo. Butler has opened up business at his old stand in Deadwood, S. Dak.

The stock of T. W. Thompson, Manitou, Col., has been sold by the assignee.

E. A. Gandrup, Glad Brook, Ia., has given a chattel mortgage for \$300.

A. Rapin, Silver Plume, Col., has removed his stock to Central City, Col.

F. D. Enney, Syracuse, N. Y., has given Ida M. Enney a bill of sale for \$1,565.

Steman & Pershon, Baltimore, Md., have dissolved, August Steman succeeding.

G. B. Bartley has opened a jewelry store in the postoffice building, Bartlett, Ill.

E. Rosenthal, Charleston, S. C., has mortgaged part of his stock for \$420.

Fred Watts, Manchester, N. H., is offering his creditors 25 cents on the dollar.

Chas. Deihl has returned to Perkins, Okla., to engage in the jewelry business.

A judgment has been entered against A. Villmock and others, Taylor, Pa., for \$500.

Geo. Rentz, Manson, Ia., has sold out his business and is thinking of locating in Clare, Ia.

James K. Parker will open a repair shop in M. E. Tobey's jewelry store, Great Barrington, Mass.

H. N. Bolte, jeweler, Atlantic City, N. J., now occupies his new brick store at 912 Atlantic Ave.

T. H. Bosworth, Millersburg, Pa., has sold out to M. J. Beckley, and will remove to Philadelphia.

A. C. Elliott and W. F. Lower, Tipton, Ia., have formed a partnership to conduct a jewelry business.

Frank A. Elmer has located as a repairer in the Western Union Telegraph Co. office, Hudson, N. Y.

M. Verdoes, Orange City, Ia., has given a bill of sale for \$1,800. The store is closed under attachments.

J. P. Foss has purchased a half interest of

R. G. Foss in the jewelry firm of J. P. Foss & Co., Oconomowoc, Wis.

Burglars broke into Couzet & Fisher's jewelry and drug store, Greenup, Ill., last week but did not steal much.

Holland & Derby, Concord, N. H., have dissolved and the business will be conducted in the future by J. G. Holland.

Cæsar Spiegler, 134 S. Main St., Bethlehem, Pa., on or before April 1st, will move his establishment to 150 S. Main St.

L. C. Harrington will soon remove from Sioux City, Ia., to go into the wholesale jewelry business in Sioux Falls, S. Dak.

Clark Bros. have succeeded Geo. R. Clark & Co., St. Cloud, Minn. Will Clark has bought out the interest of W. T. Clark, his father.

The Rushmer Jewelry Co., with W. B. Rushmer as manager, have opened up a store in the Bi-Metallic block, Cripple Creek, Col.

Cooper, Freed & Crocken, Baltimore, Md., have dissolved. Samuel Cooper withdrawing. The business will be continued by the remaining partner.

Edward M. Mitchell, who recently bought out J. N. Gibbs, Medford, Mass., has been remodeling and refitting his store and opened last Saturday evening.

Prof. Henry A. Ward, of Ward's Museum, Rochester, N. Y., while in South Carolina last week, claims to have discovered several beautiful specimens of leopardite.

William Clark who closed out his jewelry business last week, ends the life of the oldest jewelry store in Wilmington, Del. The store was started by Benjamin Clark (deceased), in 1869.

The store of the Cross Optical and Jewelry Co., Chester, Pa., was entered by thieves last Tuesday night, and several watches stolen. Entrance was gained by prying open a rear shutter.

C. T. Hopkins, Gloucester, Mass., suffered a slight loss last Friday by the fire in that city, his store adjoining the premises destroyed. The damage was mostly by smoke and is covered by insurance.

J. T. Burke, who has been connected with J. L. Winner, Wilmington, N. C., for the past two years, has decided to embark in business on his own account at 7 S. Front St.

The store of Alward & Pearson, Colorado Springs, Col., who assigned to E. A. Cohen, is reopened. It is still in the hands of the assignee. The assets are said to be twice as large as the liabilities, which amount to \$4,000.

The store in Hazelton, Pa., which was reported in THE CIRCULAR recently to have been closed out by Davidow Bros., Scranton, Pa., was not closed out by that firm, but by Meyer Davidow, who has no connection with that house.

The jewelry store of G. T. Sadtler & Sons, 16 E. Baltimore St., Baltimore, Md., was robbed late last Saturday night of opera glasses and jewelry valued at \$271. Christian Myers and Wm. Dalton have been arrested on suspicion.

R. M. York, Gouverneur, N. Y., will not remove to Champlain, N. Y., as reported recently in THE CIRCULAR. He says he will remain in Gouverneur as long as he receives the very liberal patronage that he has had for the past five years.

H. E. Adams, Sanford, Fla., has not only a fine store, and a good stock of goods, but is also time inspector for the southern division of the South Florida and Western, Jacksonville, Tampa and Key West, Florida Southern, and Sanford and St. Petersburg Railroads.

Chas. Menke, a partner in the firm of Manteli & Menke, Hutchinson, Kan., and formerly cashier of the Hutchinson National bank, which failed a few months ago, has been arrested charged with altering the books of the bank.

Dubuque, Ia. is in a fair way to secure a watch and clock factory which is to employ 300 men. The owners have been in correspondence with the board of trade of Dubuque for some time past, but hitherto they have asked too much. Now they offer to come if Dubuque will give them a suitable site.

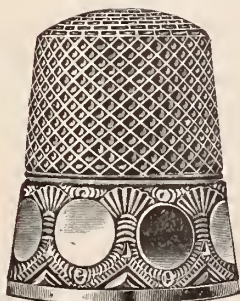

**KETCHAM & McDOUGAL**  
 MANUFACTURERS  
 GOLD & SILVER THIMBLES,  
 GOLD COLLAR BUTTONS,  
 AUTOMATIC EYE-GLASS HOLDERS  
 198 BROADWAY N Y

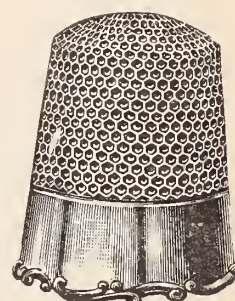



# CLASSIFIED INDEX TO ADVERTISEMENTS.

All Advertisements are entitled to one insertion under proper heading. Extra insertions, \$6.00 per annum.  
Extra Headings, \$12.00 per annum.

	Page.		Page.		Page.
<b>Art Pottery, Bric-a-brac, Etc.</b>		<b>Horological Schools.</b>		<b>Silver Mounted Ebony Goods.</b>	
Ahrenfeldt, Charles & Son, 50-52-54 Murray St., N. Y. ....	38	American Horological Institute, Lancaster, Pa. ....	23	Deutsch Bros., 7 E. 17th St., N. Y. ....	2
Bing, Ferdinand & Co., 106 Grand St., N. Y. ....	38	Chicago Watchmakers' Institute, Chicago, Ill. ....	22	<b>Silver Novelties.</b>	
Borgfeldt, Geo. & Co., 18, 20 & 22 Washington Place, New York ....	41	Elgin Horological School, Elgin, Ill. ....	21	Haskell, H. C., Corbin Building, N. Y. ....	16
Hinrichs & Co., 29 & 31 Park Place, N. Y. ....	43	Parson's School for Watchmakers, Peoria, Ill. ....	21	Provenzano, J. N., 39 Union Square, N. Y. ....	8
Straus, L. & Sons, 42 to 48 Warren St., N. Y. ....	37			<b>Silver Plated Ware.</b>	
<b>Assayers &amp; Refiners.</b>		<b>Hotels.</b>		Pairpoint Mfg. Co., New Bedford, Mass. ....	5
Baker, Geo. M., Providence, R. I. ....	43	Gibson House, Cincinnati, O. ....	22	Rogers, Smith & Co., Meriden, Conn. ....	40
Clark, J. L., Philadelphia, Pa. ....	37			<b>Sterling Silver Novelties.</b>	
Goldsmith Bros., 63 & 65 Washington St., Chicago, Ill. ....	19	<b>Jewelers' Findings.</b>		Codding Bros. & Heilborn, Attleboro Mass. ....	42
Howard, S. P., 33 Maiden Lane, N. Y. ....	44	Lind, Thos. W., Providence, R. I. ....	25	<b>Sterling Silverware.</b>	
Le Long, L. & Bro., Newark, N. J. ....	44	<b>Jewelers' Lamps.</b>		Alvin Mfg. Co., 866 Broadway, N. Y. ....	17
Rathbone, J., Providence, R. I. ....	4	Hinrichs & Co., 31 Park Place, N. Y. ....	36	Bachrach & Freedman, 1 & 3 Union Sq., N. Y. ....	35
Schawel, J. & Co., 29 John St., N. Y. ....	44			Campbell-Metcalf Silver Co., Providence, R. I. ....	43
<b>Auctioneers.</b>		<b>Jewelry Mailing Boxes.</b>		Reed & Barton, 37 Union Square, N. Y. ....	23
American Syndicate of Jewelers' Auctioneers, New York and Washington ....	43	Am. Railway Supply Co., 24 Park Place, N. Y. ....	43	Shiebler, Geo. W., Co., 179 Broadway, N. Y. ....	4
French, J. H., P. O. Box 2775, N. Y. ....	17			Towle Mfg. Co., Newburyport, Mass. ....	43
Prince, J., 137 Broadway, N. Y. ....	44	<b>Jobbers, Watches, Diamonds, Etc.</b>		Wallace, R. & Sons Mfg. Co., 3 Park Place	6
Rich, H. M. & Co., Boston, Mass. ....	28	Allen, Benj. & Co., Chicago, Ill. ....	20	Whiting, F. M. & Co., North Attleboro, Mass. ....	37
Scott, De B. O., 20 Murray St., N. Y. ....	5	Bell, O. E. & Co., Cincinnati, O. ....	22	Wood & Hughes, 16 John St., N. Y. ....	37
<b>Badges, Medals, Etc.</b>		Brethauer Watch and Jewelry Co., Chicago, Ill. ....	22		
Irons & Russell, Providence, R. I. ....	37	Cross & Beguelin, 17 Maiden Lane, N. Y. ....	2	<b>Spectacle and Eyeglass Cases.</b>	
J. W. Richardson, 200 Broadway, N. Y. ....	11	Friedlander, R., L. & M., 65, 67 Nassau St., N. Y. ....	42	Birmingham, Wm. & Co., 728 Arch St., Phila. ....	44
Schlechter, G. A., Reading, Pa. ....	44	Myers, S. F. & Co., 48 Maiden Lane, N. Y. ....	44	White, W. B. & Son, Boston, Mass. ....	38
Stockwell, E. R., 19 John St., N. Y. ....	44	Oppenheimer Bros. & Veith, 35 Maiden Lane, N. Y. ....	25		
Willson, Chas. G., Reading, Pa. ....	42			<b>Stem Winding Attachments.</b>	
<b>Clocks, French, English and American.</b>		<b>Leather and Silver Goods.</b>		Abbott, Henry, 2 Maiden Lane, N. Y. ....	28
Jacques, Chas., Clock Co., 22 Cortlandt St., N. Y. ....	44	Deutsch Bros., 7 E. 17th St., N. Y. ....	2	<b>Thimbles.</b>	
<b>Cut Glass.</b>				Ketchum & McDougal, 198 Broadway, N. Y. ....	31
Mt. Washington Glass Co., New Bedford, Mass. ....	38	<b>Musical Boxes.</b>		<b>Tortoise Shell Goods.</b>	
<b>Diamond &amp; Precious Stone Importers.</b>		Jacot & Son, 298 Broadway, N. Y. ....	2	Potter, W. K., Providence, R. I. ....	5
Disselkoe, John N., 19 E. 16th St., N. Y. ....	27			<b>Tool Manufacturers and Dealers.</b>	
Falkenau, Oppenheimer & Co., 40 Maiden Lane, N. Y. ....	44	<b>Office Building.</b>		American Watch Tool Co., Waltham, Mass. ....	24
Fera, Henry, 10 Maiden Lane, N. Y. ....	4	Cruikshank, E. A. & Co., 176 Broadway, N. Y. ....	2	Bullock, O. W. & Co., Springfield, Mass. ....	26
Hedges, Wm. S. & Co., 170 Broadway, N. Y. ....	26	Diamond Exchange Building, 14 Maiden Lane.	7	Harding Bros., Chicago, Ill. ....	23
Kipling, E. E., 182 Broadway, N. Y. ....	44	Sheldon Building, John & Nassau Sts., N. Y. ....	33	Logan, A. J., Waltham, Mass. ....	5
Kipling, R. A., Hays Bldg., N. Y. ....	26			Moseley & Co., Elgin, Ill. ....	21
Lorsch, Albert & Co., 37 Maiden Lane, N. Y. ....	44	<b>Office Furniture.</b>		Oliver, W. W., Buffalo, N. Y. ....	21
Randel, Baremore & Billings, 29 Maiden Lane	27	Schwartzwelder & Co., New York. ....	7	Waltham Watch Tool Co. ....	56
Rothschild, M. D., 41 & 43 Maiden Lane, N. Y. ....	44			<b>Trunks and Traveling Bags.</b>	
Smith, Alfred H. & Co., 182 Broadway, N. Y. ....	26	<b>Optical Goods.</b>		Crouch & Fitzgerald, 161 Broadway, N. Y. ....	38
Tannenbaum, L., & Co., cor. Maiden Lane and Nassau St., N. Y. ....	15	Berger, Albert & Co., 47 Maiden Lane, N. Y. ....	37	<b>Watch Manufacturers.</b>	
<b>Diamond Jewelry.</b>		Geneva Optical Co., Chicago, Ill. ....	21	Charmilles Watch. ....	24
Jeanne, Paul, Bradley Bldg., N. Y. ....	4	Kirstein's, H. E., Sons Co., Rochester, N. Y. ....	4	<b>Watch Case Manufacturers.</b>	
Leonhardt & Curran, 44½ Maiden Lane, N. Y. ....	16	Scheidig, John, 43 Maiden Lane, N. Y. ....	26	American Watch Case Co., Corbin Building, New York. ....	44
<b>Fine Stationery.</b>		Queen & Co., Philadelphia, Pa. ....	30	<b>Watch Case Repairers</b>	
Parsons & Greene Co., 18 Murray St., N. Y. ....	5	Spencer Optical Mfg. Co., 15 Maiden Lane, N. Y. ....	4	T. F. Tuttle & Co., Washington St., Boston, Mass. ....	30
<b>Gold and Silver Plating Works.</b>				The Planchamp & Becker Co., Chicago, Ill. ....	22
Bolstad Mfg. & Plating Co., Chicago, Ill. ....	24	<b>Paneled Metal.</b>		<b>Watch and Clock Signs.</b>	
<b>Gold and Rolled Plate Jewelry.</b>		Northrop, A. & Co., Pittsburgh, Pa. ....	28	Excelsior Sign & Mfg. Co., Chicago ....	20
Foster & Bailey, Providence, R. I. ....	3	<b>Pens, Pencil Cases, Etc.</b>		<b>Watch Dials.</b>	
Read, M. L. & Co., Providence, R. I. ....	43	The Boston Pen Co., Boston, Mass. ....	4	O'Hara Waltham Dial Co., Waltham, Mass. ....	43
<b>Gold Jewelry.</b>		<b>Patents.</b>		<b>Watchman's Clocks.</b>	
Carter, Sloan & Co., 15 Maiden Lane, N. Y. ....	27	Belt, C. T., Washington, D. C. ....	43	Hausburg, O. E., 41 Maiden Lane, N. Y. ....	37
Johnson, R. M., 67 Washington St., Chicago, Ill. ....	23	<b>Platinum Importers.</b>		<b>Watch Importers.</b>	
Kremetz & Co., 182 Broadway, N. Y. ....	2	Schawel, J. & Co., 29 John St., N. Y. ....	44	Hyde's, J. E., Sons, 22 Maiden Lane, N. Y. ....	4
Pfeil, Chas. H., Chicago, Ill. ....	21	<b>Ring Makers.</b>		<b>Watch Keys.</b>	
Reeves & Sillocks, 19 Maiden Lane, N. Y. ....	29	Bryant, M. B. & Co., 10 Maiden Lane, N. Y. ....	37	Clark, A. N., Plainville, Conn. ....	2
Schwarz, A., 866 Broadway, N. Y. ....	25	Bowden, J. B. & Co., 192 Broadway, N. Y. ....	25	<b>Watch Repairers.</b>	
Unger Bros., 192 Broadway, N. Y. ....	12	Hildreth Mfg. Co., 53 Maiden Lane, N. Y. ....	17	Muller, Hugo, Chicago, Ill. ....	21
Webster, G. A., Chicago, Ill. ....	28	<b>Rubber Stamps and Type.</b>		Henry, Peter, Cincinnati, O. ....	22
		Dietz, Wm. H., Chicago, Ill. ....	22		
		<b>Sample Trunks.</b>			
		Crouch & Fitzgerald, 161 Broadway, N. Y. ....	38		



## Special Notices.

Rates 75c. per insertion for notices not exceeding lines (25 words), additional words 2 cents each. If answers are to be forwarded, postage stamps must be enclosed. Two insertions, 15 per cent. off; three insertions, 20 per cent. off; four insertions or more, 25 per cent. off. Payable strictly in advance. Display cards on this page will be charged at \$2.00 per inch for first insertion, subject to same discount as above for subsequent insertions.

Under the heading of **Situations Wanted** on this page advertisements will be inserted for **One Cent a Word**. This offer refers to **Situations Wanted only**. Payable strictly in advance. If answers are to be forwarded, postage must be enclosed.

## Situations Wanted.

Notices under this heading **ONLY** are charged at one cent a word, payable strictly in advance. If answer are to be forwarded, postage must be enclosed.

**WANTED, SITUATION**—Manager of a business for two years past. Do all branches of work—watchmaking, engraving, seal making, jobbing, selling, buying. Box 695, What Cheer, Ia.

**SITUATION WANTED** as watch and clock maker; also jewelry repairer; age 21; speaks English and German; good references. Address A. Guenther, 875 Sixth Ave., New York.

**BY** competent, first-class watchmaker, 30 years of age; strictly temperate. Can do jewelry jobbing and clock work. Good set of tools, lathe and attachments. Had present position about 3 years. Best of reference as to character, etc. Those wanting cheap man need not apply. Please state salary in first letter. R. Jandon, 55 E. Town St., Columbus, O.

**WANTED**—Position by a young man aged 22 years. Can do clock, watch and jewelry repairing. Best of references. Address C. W. P., 413 S. Main St., Waterbury, Conn.

**SALESMAN** with a large personal acquaintance with retail jewelry trade in Buffalo and vicinity wishes to represent a few manufacturers on commission. Address Reference, care THE JEWELERS' CIRCULAR.

**SITUATION WANTED** by an A1 watchmaker jewelry jobber and engraver. Can repair repeaters, chronographs and all other fine watches; 16 year at the bench; good salesman; sober and reliable; good set of tools; A1 references. Address P. B. L., P. O. Box 412, Winchester, Ill.

**WANTED**—Position as salesman, or watchmaker and jeweler. New York city preferred. A1 references. Address V, care of THE JEWELERS' CIRCULAR.

**SITUATION WANTED** by a thorough watchmaker and jeweler after April 1st; good letter engraver; owns tools; best references. Lock Box 595, Pensacola, Florida.

**WANTED** position in Central States by watchmaker, clock and jewelry repairer, engraver and good salesman; a thorough general workman; single and sober. Address M. M. G., care of THE JEWELERS' CIRCULAR.

**SITUATION WANTED** by first-class jeweler and watchmaker, 10 years' experience; owns tools; open for engagement April 15th. Address B. P., care of THE JEWELERS' CIRCULAR.

**POSITION WANTED** by a young man, with three years' experience in watch, clock and jewelry work. Reasonable wages. Good references. Address P. O. Box 248, Reedsburg, Wis.

**SITUATION WANTED** by a boy, having three years' experience in the silver and jewelry business. Address Advance, care THE JEWELERS' CIRCULAR.

**YOUNG MAN** wishes position as second watchmaker. Can do ordinary watch, clock and jewelry repairing. Has tools and is competent. Address R. B., care of THE JEWELERS' CIRCULAR.

**A STUDENT** who desires to work and to attend college is open for any proposition. Address Kaylor, 239 E. Main St., Galesburg, Ill.

**SITUATION WANTED** by a young man who has had three years' experience at watch, clock and jewelry repairing. First class references. Address P. O. Box 249, Castleton, N. Y.

**WE HAVE IN OUR EMPLOY** a young man of excellent habits and one whom we can recommend as a good watchmaker and engraver. We would like to find him a good position. For further particulars address Hoffman & Robinson, Lyons, N. Y.

**A COMPETENT WATCHMAKER** would like a position; 18 years' experience on fine and complicated work; perfect set of tools. Address Curtis, care of THE JEWELERS' CIRCULAR.

**POSITION WANTED** by first class watchmaker having 10 years' experience; owns fine set of tools. Address Staff, care of THE JEWELERS' CIRCULAR.

**WORK WANTED FOR JEWELERS, SILVERSMITHS, ENGRAVERS, DESIGNERS, WATCHMAKERS, CASEMAKERS, TOOLMAKERS, ETC. ONLY WORKMEN WITH GOOD TESTIMONIALS FROM PREVIOUS EMPLOYERS ARE RECOMMENDED.**

**ADDRESS, JEWELERS' RELIEF ASSOCIATION, 11 MAIDEN LANE, N. Y.**

## Help Wanted.

**WANTED.**—A first-class watchmaker, who has lathe and tools; must be experienced and first-class in every way. Will pay good price to the right man. Ryan, Barrows & Parker, Middletown, Conn.

**A YOUNG, RELIABLE MAN** to dress jewelry windows and to act as salesman when not occupied in window dressing. References required. Davidow Bros., 217 Lackawanna Ave., Scranton, Pa.

## To Let.

**TO LET.**—A large office, 20x40, first floor, No. 11 Maiden Lane. \$60 a month.

**FOR RENT** in Corbin building, 11 John St., sixth floor, half of an office with or without large safe convenient for jeweler. For further particulars, address the janitor of the building.

**BROADWAY STORE** near the Post Office; desirable location; moderate rent; lease. Apply on premises, 2 Astor House.

**CORNER STORE TO RENT,** 21½x85, No. 20 Maiden Lane. Possession May 1st. Terms reasonable. Inquire Room 9, above store.

## Miscellaneous.

**I BUY JEWELRY STOCKS**—Manufacturers, jobbers and retailers desiring to dispose of surplus or entire stocks of diamonds, watches and jewelry can find quick cash buyer by addressing Stephen S. Harmon, 134 East 96th St., New York City.

**RICH** cut glass to exchange for rings, diamonds, watches, china and silver ware. Brighton Glass Cutting Co., New Brighton, Pa.

**STOLEN**—A gold watch, 14 karat case. Marked inside E. T. E. B. E. C. No. 634,923. E. Howard & Co. movement, No. 220,614. The watch needed repairs; make note of numbers so as to stop it if offered. A suitable reward for its recovery. Address B, P. O. Box 284, Hartford, Conn.

## DEMAGNETIZING.

**PERFECT WORK**—Watch repairing in all its branches; all work warranted. Winslow & Penney, 608 Masonic Temple, Chicago.

**FOURTEEN karat gold solder** that will flow on eight karat work; makes a hard solder job a pleasure. With this solder there is no danger of melting low karat specs. No white joints on rings. It is just what you want. Sample by mail 25 cents. F. W. Hall, Sterling Silver Novelties, Columbus Memorial Building, Chicago, Ill.

**WANTED TO PURCHASE.**—Good paying jewelry store for cash in New York or Brooklyn. Address L. B., care THE JEWELERS' CIRCULAR.

## For Sale.

**FOR SALE.**—A first class polishing lathe; all in good repair, at a low price for cash. Address G. W. Brown, 113 Point St., Providence, R. I.

**FOR SALE**—A first-class optical store, stock and fixtures, in a city of over 100,000 inhabitants in New York State. Best location in city; for full particulars address A1 Chance, care of THE JEWELERS' CIRCULAR.

**\$450** buys a stock of jewelry and fixtures in a town of 1,000 inhabitants; no other watchmaker within 25 miles of me. Address at once C. R. Keil, Thorpe, Wis.

**FOR SALE.**—A first-class jewelry store in a city of 10,000 inhabitants, southern Pennsylvania; large, roomy store with two plate glass front and side show windows, 5x5 by 10 feet high; a nice clean stock, fixtures almost new. Will invoice \$5,000; can be reduced to \$3,500; over three-fourths of stock consists of staple goods; good run of bench work; must be sold at once; a good discount allowed to cash purchaser. For full particulars address Good Chance, care THE JEWELERS' CIRCULAR.

**A FINE CHANCE** in Washington, D. C.—Having been called away from the city by reason of sickness will sell my watch and clock repairing business at a low figure; it consists of a large safe, large regulator, show case, counter, two benches, two watch racks, crystal case, material box and contents, show watch, signs, and a small stock of jewelry, located on the principal business street; rent \$15 per month, paid to April 1st; immediate possession given; repairing varies from \$25 to \$35 per week; considerable work on hand to be called for; everything in good shape to sit down at the bench and go to work; a reliable apprentice, who understands cleaning and repairing, will remain if wanted; price \$250. Address Jeweler, 612 G St., N. W., Washington, D. C.

**\$5,000** for long established retail Jewelry business in city of 100,000 inhabitants;

**YEARLY PROFIT ABOVE EXPENSE, \$3,500.** Can be greatly increased by additional capital if desired.

Satisfactory reasons for selling given to parties with necessary cash capital. Address, CHANCE, care of THE JEWELERS' CIRCULAR.

## SAFES FOR SALE.

(CHOICE OF TWO.)

Will sell at one fifth the original cost; size, 56x38 inside measurement. Apply to or address,

**OPPORTUNITY,**

Care THE JEWELERS' CIRCULAR.

## FOR SALE.

The Old Established Jewelry Business of G. A. SCHULTZ (Dec'd), is for sale at a great bargain. New fixtures throughout; good location. Address

**HELENA SCHULTZ, Ex'trix,**

Corner 7th & Market Streets, LOUISVILLE, KY.

## FACTORY AND OFFICE TO RENT FROM MAY 1ST.

Desirable office on first floor with factory on fourth floor. John St., between Broadway and Nassau St. Office, 25x40; factory 25x75. Both connected by elevator and speaking tube. Factory well lighted and ventilated by four high sky-lights. Steam power according to wants. Rent \$2,000, or factory alone \$1,000. Address A. B. care JEWELER'S CIRCULAR

## TO LET! PART OF STORE.

**Chas. Jacques Clock Co.**

22 CORTLANDT STREET, NEW YORK.

# SHELDON BUILDING,

S. E. CORNER JOHN & NASSAU STS.

A few offices remaining in this modern fire-proof building can be had at moderate rates. Excellent light, two rapid running elevators and all modern improvements. For plans and particulars apply to

**GEO. R. READ, AGENT,**

9 PINE STREET, NEW YORK.



### Newark.

Henry Glorieux is on an extended trip through the south and west.

Robert Hunt, a jeweler, was taken suddenly ill last week while walking on Mulberry St., and fell to the pavement. He was removed to St. Michael's Hospital.

The Eglinton jewels are to be dispersed at Christie & Manson's on the 22d. Among them are a necklace, earrings and brooch which are said to have belonged to Mary Queen of Scots. The jewels are of enameled gold, set with rubies, emeralds and pearls.

The Sloan & Chace Mfg. Co., Limited, of this city, have incorporated with a capital stock of \$100,000 in single shares of \$100 for the manufacturing, selling, leasing and dealing in watch factory equipment, general machinery and specialties, etc. The incorporators are: Augustus K. Sloan, Brooklyn, N. Y.; Chas. T. Sloan, and Geo. E. C. Chace, Newark, N. J.

### Pittsburgh.

H. C. Reineman has returned from Florida.

Anderson Block, formerly with George Cohen, will open a jobbing house at 21 Diamond St.

Goddard, Hill & Co. were robbed of two gold charms by a slick young fellow who worked the usual game of looking at goods intending to purchase.

Buyers in town last week were: Bert Neville, Dawson, Pa.; F. H. Hayes, Washington, Pa.; L. Furtwanger, Greensburg; Sam Wise, Frederickburg, W. Va.

During the past week some malicious individual has been making a practice of scoring jewelers' windows with a diamond. Several Fifth Ave. windows have suffered, and B. E. Aron's loss will amount to \$50.

A. Grafner, of Grafner Bros., will withdraw from the firm to take charge of the newly established jewelry department of Solomon & Ruben's stores. Mr. Grafner will be assisted by Mr. Spandau, of Liberty St.

Among the beautiful Easter windows are those of E. P. Roberts & Sons, W. W. Wattles & Sons, Shaefer & Lloyd, Hardy & Hayes, and J. C. Grogan. A large bell of daffodils is a distinguishing feature of Roberts' large central window, and a bunch of flowers representing \$12,000, of Grogan's.

### It Looks Rather Dark for Charles Homans, of California.

Monday afternoon about 12.30 o'clock, a man about 30 years old, with smooth face, light hair, blue eyes, five feet six inches in height, called upon Hayden W. Wheeler & Co., 2 Maiden Lane, New York, and desired to look at some diamonds, claiming that he was the son of a jeweler of the name of Lewis, of Philadelphia, Pa. He selected diamonds to the amount of \$1,200, and presented as part payment a certified

check for \$1,150, drawn by Aldrich, Iddings & Clifton, 256 Church St., and payable to the order of A. P. Lewis.

Hayden W. Wheeler & Co., following their usual custom in dealing with strangers, declined to deliver the goods until Mr. Lewis was identified to their satisfaction. The man sat down to wait until a messenger was sent to the bank to ascertain if the check was good. The signature of the check was pronounced all right by the bank, but they knew nothing regarding the indorsement. Hayden W. Wheeler & Co. then sent a messenger to Aldrich, Iddings & Clifton, who pronounced the indorsement a forgery.

While the investigation was in progress the man had left the office, saying he would call again. This he did just as the messenger returned, and reported to a member of the firm that the indorsement was a forgery. Thereupon the man was retained until an officer was called, who placed him under arrest. He was taken to the Tombs Police Court, where he gave the name of Charles Homans, of California, but would give no explanation as to how the check came in his possession. He was remanded by Police Justice Martin for examination. The examination took place shortly after THE CIRCULAR went to press.

### Elmira, N. Y.

A. J. Watson is auctioning off a large stock of diamonds and jewelry at his place of business.

The home of Mr. and Mrs. Aaron Samuels was the scene of joyous festivities Sunday evening, the event being the anniversary of their silver wedding. Their handsome home was beautifully decorated, and an orchestra furnished the music.

T. E. La France has left the employ of James Wise and has charge of the jewelry business of J. E. Swartout for the next two weeks during his absence in New York city. Messrs. La France and Swartout are soon to open an elegant jewelry establishment in this city.

### Cleveland.

The Wangsaac & Power Art Co., 1224 Euclid Ave., made an assignment, Tuesday last to John T. Norton, for the benefit of creditors. The store was closed on a cognovit, Monday. The assets are estimated at \$3,000, and liabilities are somewhat larger. The firm is composed of John Wangsaac, Frank W. Power and Mrs. Jessie Wangsaac.

E. H. Deslems, jeweler, Ada., O., made an assignment, recently, to S. W. Ennis. E. & J. Swigert, Cincinnati, then made haste to foreclose a chattel mortgage for \$1,585.69, given last May. This was followed at once by Jos. S. Voss & Son, Cincinnati, sending a man to look after a good sized claim for goods consigned on commis-

sion. There are also a number of local creditors in small amounts, and the total indebtedness will amount to over \$3,000. The stock is very low, so that the Swigert mortgage will probably clean it up. It is said that a large amount of goods has been sold at auction at Dunkirk, Ind.

L. H. Goldsoll, of L. H. Goldsoll & Co. is reported to have left the State. Shortly after the holidays he was arrested on the charge of participating in a lottery scheme in the disposal of a farm in Orange Township. Now suit has been commenced in common pleas court here for the appointment of a receiver. R. L. Griffith & Son are the plaintiffs, and they represent debts aggregating \$25,000. In the petition L. H. Goldsoll is charged with fraud and gross violation of business integrity. It is alleged that Goldsoll has pledged property belonging to plaintiff to the Merchants' Banking Co., and that he has fled from the State.

Thomas W. Lind, Providence, R. I., has a new rococo pattern which has taken the trade by storm. In design it is chaste and artistic and in use adapts itself to a marvelous variety of work. Send to him for samples if you haven't seen it.

Something entirely new and original in sterling silver ornamented belts is the beautiful "Duchess" belt introduced by Reeves & Sillocks, 19 Maiden Lane, New York. As may be seen from the illustration, which appears in the advertising columns of this issue, this belt is of the finest workmanship, and in design is one of the most graceful and artistic on the market. A feature of these belts are the buckles at both front and back. The prevailing craze for beautiful belts cannot but receive an impetus through the introduction of this exquisite novelty.

Among the many dainty Easter novelties shown by the Pairpoint Mfg. Co., New Bedford, Mass., are some peppers and salts simulating chickens just emerging from the shell, individual salts in the shape of the empty shell as the chick leaves it and an entire egg salt, handsomely decorated. For flowers, particularly short stemmed ones, there is a dainty pail with perforated cover which may be removed without disarranging the bouquet, some particularly handsome Easter lily vases decorated and in crystal glass, and decorated flower globes, hand decorated ranging from three to seven inches in diameter. For bouquets they show an excellent thing in a holder which by means of two small pins stays firmly attached and forms a beautiful appendage to the bouquet.

The stock of the insolvent firm of Edmund Eaves & Co., Montreal, has been sold by their liquidators, to J. U. Foucher, who will carry on the business under the name of Edmund Eaves & Co., at the old stand, Temple Building.

The store of Thos. Ticknor, Parkhill, Ont., was burnt out last week.



# MATTERS IN JEWELRY STOREKEEPING.

That this department shall prove mutually beneficial to our readers, it is desirable that the members of the trade generally communicate with THE CIRCULAR regarding any advantageous device or plan they are utilizing in the conduction of their business.

### Improved Work Bench.

**A.** E. KEEPOR, an expert workman of Reading, Pa., sends THE CIRCULAR a photograph of his work bench, accompanied by the following letter:

*Editor of THE JEWELERS' CIRCULAR:*

For the benefit of some of the unfortu-

it, so that I never need move it while sitting. I employ a slide covered with leather ducking.

The bench proper is 38 inches high to the top surface and 24x48.1½. The additional bench is 16 inches high, 12x48¾; there are three drawers, size 6x4 inside, on right side, and slide covered with ducking 22x30; the



A CONVENIENT WORK BENCH, BY A. E. KEEPOR.

nates as myself, I offer here the subject of a good cheap work bench. It is the most practical one I have seen or worked at, and I have been at the bench for about 30 years, in both job shop and factory. One sitting all the time becomes very tired, and does not get any exercise; but standing to some extent makes all the difference in the world. To accomplish this in both an economical and practical form is the object of this work bench.

The whole cost of the bench is not more than about \$6, and it is made of poplar wood and oil finished. On the right hand side I have an extension attached with two large iron brackets; when I have my lathe on, by sitting at the end I obtain the best possible light, the window being in front of the bench; while standing I use a spring board. I use a chair to sit upon. The board is narrow enough to allow the chair to span

extra addition for the lathe is 21x24½; on it I use a post or upright, 14 inches high, upon which is the countershaft. By raising the shaft I get better working results, and can use any lathe attachments I may wish to advantage.

A. E. KEEPOR.

### A Handsome Trade Sign.

**T**HE handsome trade signs of the Wadsworth Watch Case Co. are ready for shipment to dealers in their product. Two styles have been provided, a large sign for wholesale and a smaller for retail houses. The jobbers' sign is beautiful in both design and colorings. On a black enamel ground artistic silver and gilt lettering is attractively displayed. In a rectangular block in the center are the words Newport, Ky., in silver on a shaded maroon background and at each end of the centerpiece is a trade mark

—on the right a pilot, on the left a monogram—in gold on a background of blue encircled by silver. The sign is appropriately framed in mahogany or oak. The retail sign is perhaps even more artistic by the addition of a gold dragon and scroll work. The colorings are similar on a yellow background with silvered frames. Each is an ornament to any office.

### A Taking Advertising Device.

**T**HE recent smashing of the large plate glass window of the store of George H. Wood, Lowell, Mass., gave occasion for the issuing of a unique advertising device, in the shape of a little card, upon one side of which appears the following:

### A SPRING CANTO.

One winter's day, towards six o'clock,  
This hustling town received a shock;  
A reckless thief, with gall and brass,  
Crashed in our large French plate glass.  
The awful deed that we relate  
Was done by a heavy carriage weight.  
The thief he had a gall sublime,  
He tried to get away with time,  
But he only got across the street,  
When stalwart men had pinned him neat.  
There was no cause for stealing so,  
For all the goods were marked quite low,  
Much lower than where else you go.

### GEORGE H. WOOD,

The Largest Leading Low-priced Jeweler in Lowell.

143 to 151 Central St.

On the reverse side is a neat local timetable of trains to and from Boston.

J. C. Walk & Son, Indianapolis, Ind., use the backs of the street car transfer tickets to call the public attention to their stock of diamonds, watches and jewelry.

## EASTER GREETING.



### Novelties

in  
**Sterling Silver**

**BACHRACH & FREEDMAN,**

**Silversmiths,**

**1 & 3 UNION SQUARE,**

**NEW YORK.**

Write for Samples.



**The Latest Patents.**

ISSUE OF MARCH 13, 1894.

**516,180. TOOL FOR EXPANDING RINGS.**

HERMAN V. BERNHARDT, Brooklyn, assignor to the J. B. Bowden & Company, New York, N. Y.—Filed Nov. 26, 1892. Serial No. 453,247. (No model.)

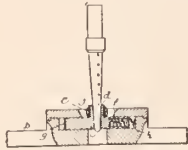

In a device for expanding rings, the combination of a base, movable jaws in said base adapted to support a ring, springs placed in recesses in said jaws and tending to move the same toward a common center and a mandrel or swage for expanding said ring.

**516,211. FINGER-RING.** CHARLES M. LEVY, New York, N. Y.—Filed July 24, 1893. Serial No. 481,366. (No model.)

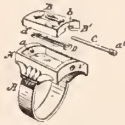

The setting formed with a dovetailed groove in its under surface and a plate fitted in said groove and the gem-box having apertures in opposite walls thereof, in combination with a retaining pin passed through said apertures and between the said plate and setting.

**516,315. FOUNTAIN-PEN.** CHARLES E. BROWNING, Toledo, Ohio.—Filed Sept. 15, 1892. Serial No. 446,002. (No model.)

**516,169. PROCESS OF FINISHING METAL.** NATHANIEL L. BRADLEY, Meriden, Conn., assignor to The Bradley & Hubbard Manufacturing Company, same place. Filed Jan. 8, 1894. Serial No. 496,115. (No specimens.)

A process of finishing metals in imitation of the antique, consisting in first spattering the surface to be finished with a liquid composition of a character not attacked by the acid subsequently employed, then subjecting the subject so spattered to the action of an acid which will eat away the unspattered portions of the metal, then cleaning the metal to remove the acid and the spattered material then filling in the depressions formed by the action of the acid with a pigment, and then applying pigment of another color to the salient points or remaining portions of the original surface of the metal.

**FOR JEWELERS' USE.**

G. A. Kleemann's Patent Improved Student Lamp.

C. A. Trade Mark.

**THE GERMAN AMERICAN.**

It preserves all the improvements which have made the St. Germain Student Lamps acceptable to Watchmakers and Mechanical Jewelers, but is a much larger Lamp, fitted with a nine-inch shade and its new large burner—far superior to that of the St. Germain—gives a light nearly double in brilliancy.

Steady white light, perfect combustion, without much heat, safe against explosion.

Will last a lifetime. Wick easily adjusted. Illustrated circular free.

**HINRICHS & CO.,**  
29, 31 & 33 PARK PLACE,  
NEW YORK CITY.



**516,539. WATCH-BALANCE STAFF AND BEARING.** CHARLEY A. JOHNSTON, Ellis, Kan. Filed April 22, 1893. Serial No. 471,416. (No model.)

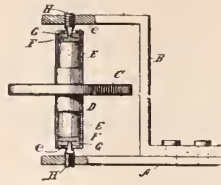

The combination with a balance staff of jeweled bearings mounted in the ends thereof, a support and adjustable journal pins in the support having their ends extended into the bearings.

**516,614. TIME-ALARM BED.** GEORGE Q. SEAMAN, Brooklyn, N. Y. Filed Aug. 22, 1893. Serial No. 483,740. (No model.)

**DESIGN 23,108. HANDLE FOR SPOONS, ETC.** JOHN H. ROCK, Bridgeport, Conn., assignor to the Holmes & Edwards Silver Company, same

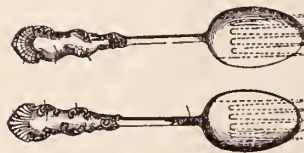

place.—Filed Dec. 11, 1893. Serial No. 493,409. Term of patent 14 years.

**DESIGN 23,106. ADVERTISING BREASTPIN.** GEORGE H. ELMER, Baltimore, Md.—Filed Nov.



9, 1893. Serial No. 490,482. Term of patent 3½ years.

**DESIGN 23,111. TRAY.** FREDERICK RATCLIFF, New Bedford, Mass., assignor to the Pairpoint Manufacturing Company, same place.—Filed Jan.

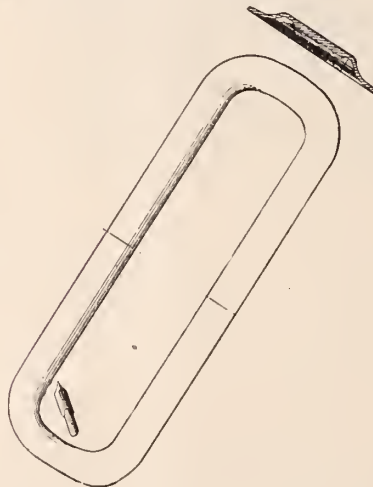

26, 1893. Serial No. 450,919. Term of patent 7 years.

**Expired Patents.**

EXPIRED MARCH 13, 1894; GRANTED MARCH 13 1877.

**183,216. SPECTACLES.** J. JOHN ON, Lowell, Mass.—Filed Aug. 26, 1876.

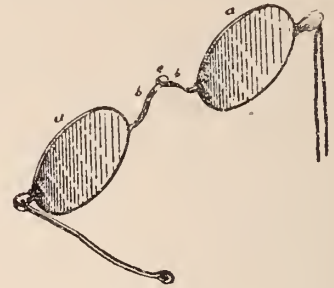

The folding spectacles, heretofore described, consisting of the jointed nose-piece formed in two parts, *b* and *b'*, having bifurcated ends, the rims *a*, and temples *c*, provided with ring *d*.

**188,261. CLOCK-CASES.** A. T. ROBINSON, Bristol, Conn., assignor to Geo. A. Jones, same place.—Filed Oct. 25, 1876.

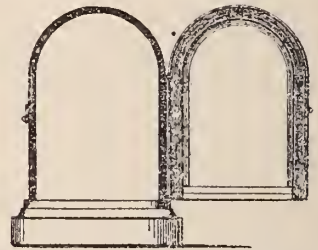

A clock-case, the top and sides of which are formed of veneers, each of which is made of a single continuous piece of wood, and united at their ends to the base-piece of the case.

**188,264. EYEGLASSES.** JOHN S. SPENCER, New York, N. Y.—Filed Jan. 22, 1877.



The dies of the character above described, for making frames for glasses or other articles out of plastic material, or material that can be made plastic.

**188,267. STUDS AND BUTTONS.** L. TOWNE,

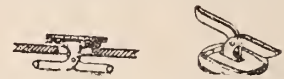

Providence, R. I.—Filed Jan. 5, 1877.

**183,123. EAR-RINGS.** LOUISA A. WEED



Brooklyn, N. Y.—Filed June 3, 1876.

**Prices of LATHES and CHUCKS are "WAY DOWN"**

All purchasers of our THREE FOUR lathes and chuck combinations now receive FREE our new TIP OVER "T REST", on which we have patent pending. The most valuable addition to plain-lathe in recent years.

SEND FOR FEB. PRICE LIST.

**WALTHAM WATCH TOOL CO., SPRINGFIELD, MASS**

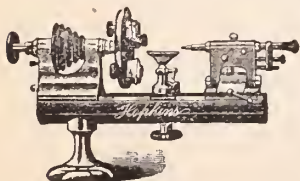





TRADE MARK.

# L. STRAUS & SONS,

IMPORTERS AND MANUFACTURERS,



TRADE MARK.

China, Pottery and Glassware, 42, 44, 46 & 48 Warren St. and 116 Chambers St., N. Y.  
PARIS, CARLSBAD, RUDOLSTADT, LIMOGES, STEINSCHONAU.

**O**NE FEATURE  MATTERS  
OF IN  
THE JEWELERS' CIRCULAR. JEWELRY  
ONE OF MANY, STORE KEEPING.

SEE PAGE 35.

**Headquarters**  Price, Complete \$10.00

FOR ELECTRIC & PORTABLE Watchman's Clocks

Lowest Prices. Latest Improvements, Patents 1888-1893. Send for Circular.

**E. O. HAUSBURG,**  
41 Maiden Lane, New York. THE "ALERT."



**WOOD & HUGHES,**  
STERLING SILVERWARE MANUFACTURERS

New York Agents for the Derby Silver Co.'s  
FINE QUADRUPLE PLATED WARE,  
No. 16 JOHN STREET, NEW YORK.  
206 Kearney St., San Francisco, Cal.  
HASKELL & MUEGGE, Agents.



**IRONS & RUSSELL,**  
(SUCCESSORS TO CHARLES F. IRONS.)

MANUFACTURERS OF  
SOLID GOLD EMBLEMS ROLL PLATE  
PINS, CHARMS AND SOLID GOLD RINGS.

102 Friendship Street, - - Providence, R. J.



## The "Bryant" Rings.

Are widely advertised and will sell  
when anything will, therefore  
every Retail Jeweler should buy them.

IF NOT CALLED UPON BY OUR TRAVELERS  
ORDER DIRECT FROM

**M. B. BRYANT & CO.,** 10 MAIDEN LANE, N. Y.  
OLDEST RING MAKERS IN AMERICA.



2 DIAMONDS - 823

MARQUISE 800

TURQUOISE & PEARLS 815

TURQUOISE & PEARLS 913

920

94

ESTABLISHED 1870.

**J. L. CLARK,**  
SWEEP SMELTER AND REFINER OF GOLD AND SILVER.  
Buys every kind of Gold and Silverware, Jewelry, Watches and Platinum. Full market value paid.

No. 724 Filbert Street, Philadelphia, Pa.  
SEND BY EXPRESS or Registered Mail. If my price is not satisfactory, I will return all articles

**ALBERT BERGER & CO**  
47 MAIDEN LANE, N. Y.  
Spectacles & Optical Goods,  
GROUND LENSES A SPECIALTY.



TYROL FAN ALMOND SCOOP, No. 15.

We are continually producing new ideas in  
Sterling Silver Hollow Ware, Toilet Articles, Novelties, &c., as well as in Flatware.

New York Office,  
857 BROADWAY  
AFTER MAY 1ST,  
at 1128 BROADWAY  
and 208 FIFTH AVE.



Handsome New Catalogue Showing 22 Patterns in Teas, and 36 Patterns in Coffee Spoons, will be mailed on application.



# FERDINAND BING & Co.,

106 GRAND ST., N. Y.

—NEW DESIGNS IN—

China Clocks and Gilt Bronze Sets, Fine Painted Dresden Goods in  
Vases, Cups and Saucers, and Plates; Cararra Marble Statuary,  
French Cabinets and other Fancy Furniture.

## Rich Cut Glass

AND

## DECORATED ART WARES.

Mt. Washington Glass Co.,

New Bedford, Mass.

RICH DISPLAY OF GOODS AT

New York Store: 46 Murray St.

When you visit Chicago do not fail to inspect our full line of goods at the new store of Pairpoint Mfg. Co., 224 Wabash Avenue.

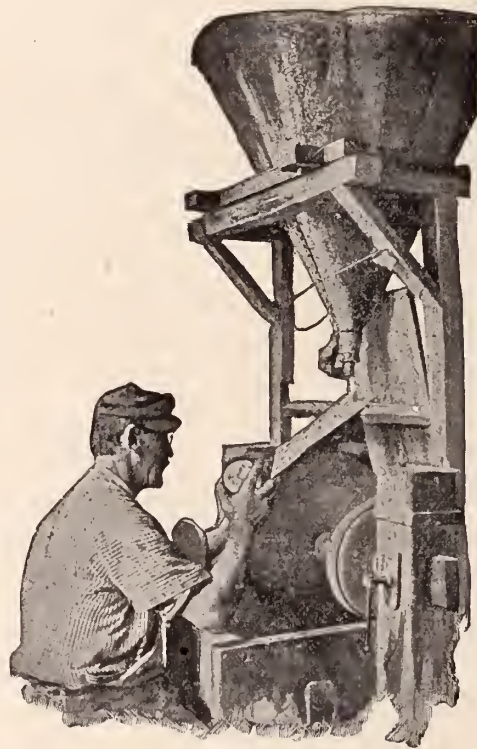

GLASS CUTTER AT WORK.

WHITE'S EYE SHADE. **W. B. WHITE & SON**



MANUFACTURERS OF  
Spectacle and Eye Glass  
CASES

90 SOUTH STREET, BOSTON.

Special Cases made to order for Optical Trade. Cases for Trial Lenses. Opera Glasses recovered, etc. Chatelaine Spectacle Cases. Metal Bound Leather Cases for combs, scissors, etc. Over forty kinds of cases manufactured.

**CROUCH & FITZGERALD.**

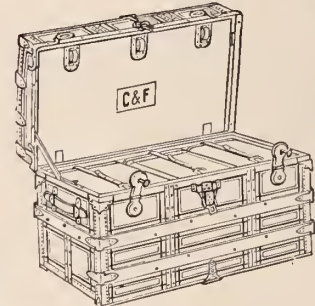

Jewelry Trunks  
and Cases.  
161

Broadway,  
Bet. Cortlandt and  
Liberty Sts.,  
688 B'way,  
701 6th Ave.,  
NEW YORK.

**LEGENDS OF GEMS.**

BY FRANK SHELLEY.

Gilt edged; bound in leather; a perfect specimen of the printer's and binder's art. Should be in every jeweler's library. Price, \$1.00. For sale by

THE JEWELERS' CIRCULAR PUB. CO.

OUR IMPORT LINES OF

# CHINA, GLASS and BRIC-A-BRAC

..... ARE COMPLETE .....

WE CALL PARTICULAR ATTENTION TO THE FOLLOWING SPECIALTIES:

LIMOGES CHINA AND SAXONIA WARE, ROYAL DRESDEN CHINA, SEVRES PORCELAIN,  
PARIS NOVELTIES, VIENNA CROWN WARE, ROYAL BONN AND DELFT  
FAIENCE, AUSTRIAN GILT GLASS.

# CHARLES AHRENFELDT & SON,

50, 52 & 54 MURRAY STREET, NEW YORK.





## ORIENTAL ART PRODUCTS FOR JEWELERS.

### PART III. TEAKWOOD FURNITURE, ETC.



TEAKWOOD TABLE.

AMONG the artistic products of the East, for which the demand in America is constantly increasing, carved cabinets and furniture in teakwood hold a permanent place. The Chinese are and have been famous for their marvelous achievements in carving in this celebrated Asiatic wood, and their products in this line have always been highly prized by lovers of bric-à-brac.

Though known for years to collectors and connoisseurs, teakwood furniture has not been seen here in the general market until very recently. At the present time it is being extensively introduced, and the demand for it keeps steadily increasing. Among the principal importers to whom its popularity is greatly due are A. A. Vantine & Co., 877 Broadway, New York, who keep on hand one of the largest and most varied assortments of teakwood cabinets, furniture, pedestals, etc., ever shown.

The teak, which is found only in the vicinity of India, is a tree remarkable for its size and beauty. It grows over 200 feet high, and has leaves of an elliptical shape about 12 by 24 inches. The wood of the teak, which has been famous for centuries, is one of the most remarkable known, by reason of its great weight, hardness and durability, qualities which have caused it to be long used not only for beautiful carvings but in the construction of temples, dwellings and ships. It is naturally of a brown red color,



TEAKWOOD PEDESTAL.

and resembles coarse mahogany. It is easily worked and is strong and durable, and contains an oil which prevents nails or other metal objects coming in contact with it from rusting.

In their manipulation of this wood the Orientals present striking examples of their

great patience, as well as their wonderful skill in carving. A peculiarity of carved teak, which is to be seen in almost all the lines shown by A. A. Vantine & Co., is that the carving extends through the wood,

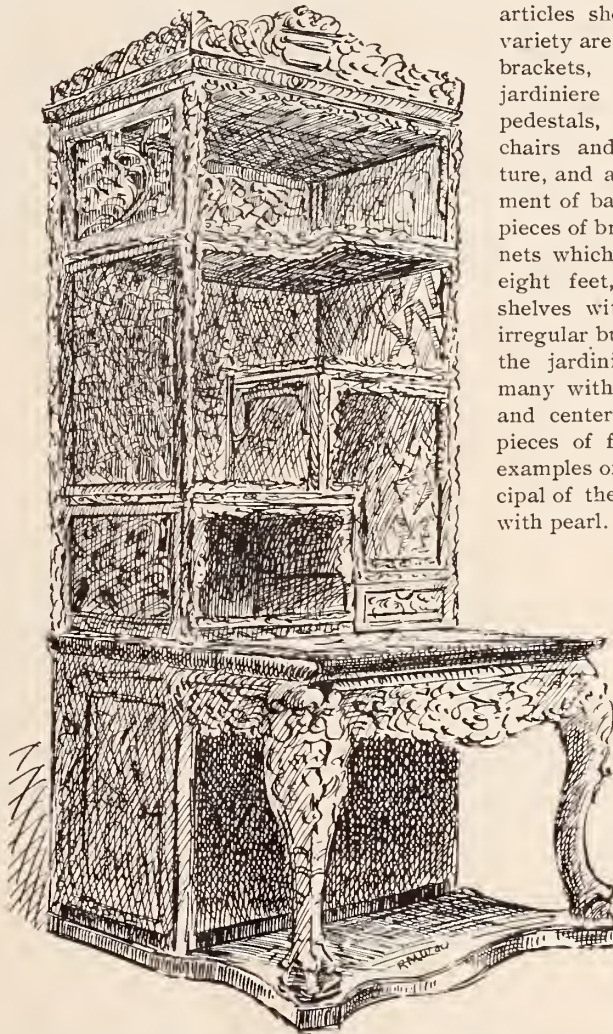

LARGE CARVED TEAKWOOD CABINET.

making a design of pierced work. The designs themselves are formed of flowers, vines, leaves or fruits of some of the plants peculiar to the Celestial empire.

In nearly all their teak lines, Vantine &

Co. show the pieces, whether they be the small two-inch ornament stands or the eight-foot cabinets, in both black and in the natural red color. Among the articles shown in great variety are cabinets, wall brackets, tea tables, jardiniere stands and pedestals, book racks, chairs and other furniture, and a large assortment of bases for special

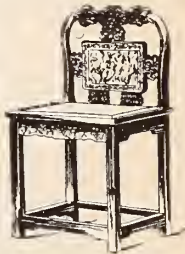

TEAKWOOD CHAIR.

pieces of bric-à-brac, silver, etc. The cabinets which vary in height from four to eight feet, show intricate carving; the shelves with their carved railings are in irregular but artistic arrangement. Among the jardiniere stands and pedestals are many with marble tops. In the tea, card and center tables, and some of the other pieces of furniture, are to be seen many examples of very dense carving. The principal of these pieces are beautifully inlaid with pearl.

### The Liberty and Progress Vases.

THE two enormous vases, "Liberty" and "Progress," which gained so much admiration at the World's Fair, where they won a medal, have been for the past week on exhibition at 66 W. 23d St., N. Y. These vases were manufactured by the Victoria China Works, Carlsbad, Bohemia. They were designed and painted by Prof. A. Griel, of Vienna. The paintings on the vases are: "Discovery of Steam Power," "The Abolition of Slavery," "Landing of Columbus," "Discovery of the Use of Electricity," "Magna Charta," "Invention of Gunpowder," "The Taking of the Bastille," and "The Battle of Sempach." The vases are valued at \$10,000. The details of the pict-



**The Connoisseur.**

(Continued from page 39.)

ures were fully explained in an article on the World's Fair exhibit of Lazarus, Rosenfeld & Lehman, which appeared in THE CIRCULAR of June 7, 1893.

**The Rambler's Notes.**

WHAT THE RAMBLER SAW AND HEARD AMONG THE DEALERS IN ART POTTERY, CUT GLASS, BRONZES ETC.

RICH JEWELLED GLASS.

**T**HE statements which have often appeared in

these columns in regard to the wonderful richness and artistic beauty of the jeweled glass of to-day, are more than confirmed by an inspection of the magnificent assortment of this ware in the warerooms of Chas. Ahrenfeldt & Son, 52 Murray St., New York. For some years this firm have made jewel glass one of their specialties and have endeavored to comprise in their line the richest and most artistic pieces to be found in the market. In addition to the regular full line of vases, flower holders, glasses, novelties, etc., they now show a very large number of sets in cases. Among these are whisky sets, cognac sets, liqueur sets and some handsome boudoir sets, containing powder and puff boxes and cologne and scent bottles. These sets which have the

richest gold decorations, are of various colored glass, and in many cases variegated colors are shown on each piece. Among the latest novelties in single pieces are pin and pen trays in an entirely new and artistic shape

THE DEMAND FOR PLATEAUX

\* **P**LATEAUX have become an almost absolute necessity to

the jeweler handling cut glass and articles of a similar character, and who desire to display their wares to the best possible advantage. Plateaux are now to be had in any desired size and in various forms. The assortment shown by Maddock & Co., 21 Barclay St., New York, contains both the plain and beaded mirrors, with or without serrated border.

RARE JAPANESE PRINTS.

\* **A** FINE collection of old Japanese prints, the property of

S. Bing, of Paris, is on view at the American Art Galleries, New York. It is a revelation of the art of the Japanese wood engraver, and Mr. Bing has written an interesting sketch of the history of the art as a preface to the catalogue.

A DISPLAY OF PAINTING ON PORCELAIN.

\* **T**HE second annual exhibition of the New York

Society of Ceramic Arts commenced last week at the rooms of the Ohio Society, 236 Fifth Ave., New York. The display, which

is a large one, indicates that the art of painting upon porcelain is being practised by growing numbers of people. Most of the artists represented in the exhibition are women. The objects on view are of all sorts, from students' pipes with the bowls appropriately illustrated, to fish sets of dozens of pieces and standing lamps on which there are Shakespearian scenes depicted.

THE QUALITIES OF BODENBACH WARE.

\* **B**ODENBACH, a heavy Austrian faience of queer colors

and shapes, but withal very attractive in appearance, is shown by Hinrichs & Co. 31 Park Place, New York, in extensive and rich variety. Vases, wall hangers, fancy baskets, fruit bowls, jardinières, cabinet ornaments, pedestals and large and small figures are to be seen, plain or in rich combinations of colors, decorated with open work, heavy raised flowers or figures. Some are attractively ornamented in an antique style. These pieces range in size from the small cabinet ornament to the enormous figures and jardinières with pedestal bases. In this same line is displayed an assortment of fine Easter novelties, consisting of candy and bon-bon boxes and dishes, as well as ornamental pieces, in forms and decorations representing chickens, eggs and rabbits. This but supplements a large and rich assortment of Easter novelties in other lines.

THE RAMBLER.

**ROGERS, SMITH & Co.**

UNION SQUARE,  
NEW YORK.

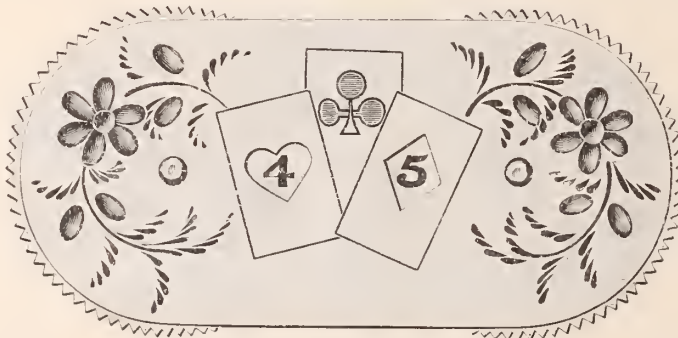

CARD COUNTER.

MERIDEN,  
CONN.

**GOLD AND SILVER PLATE.**



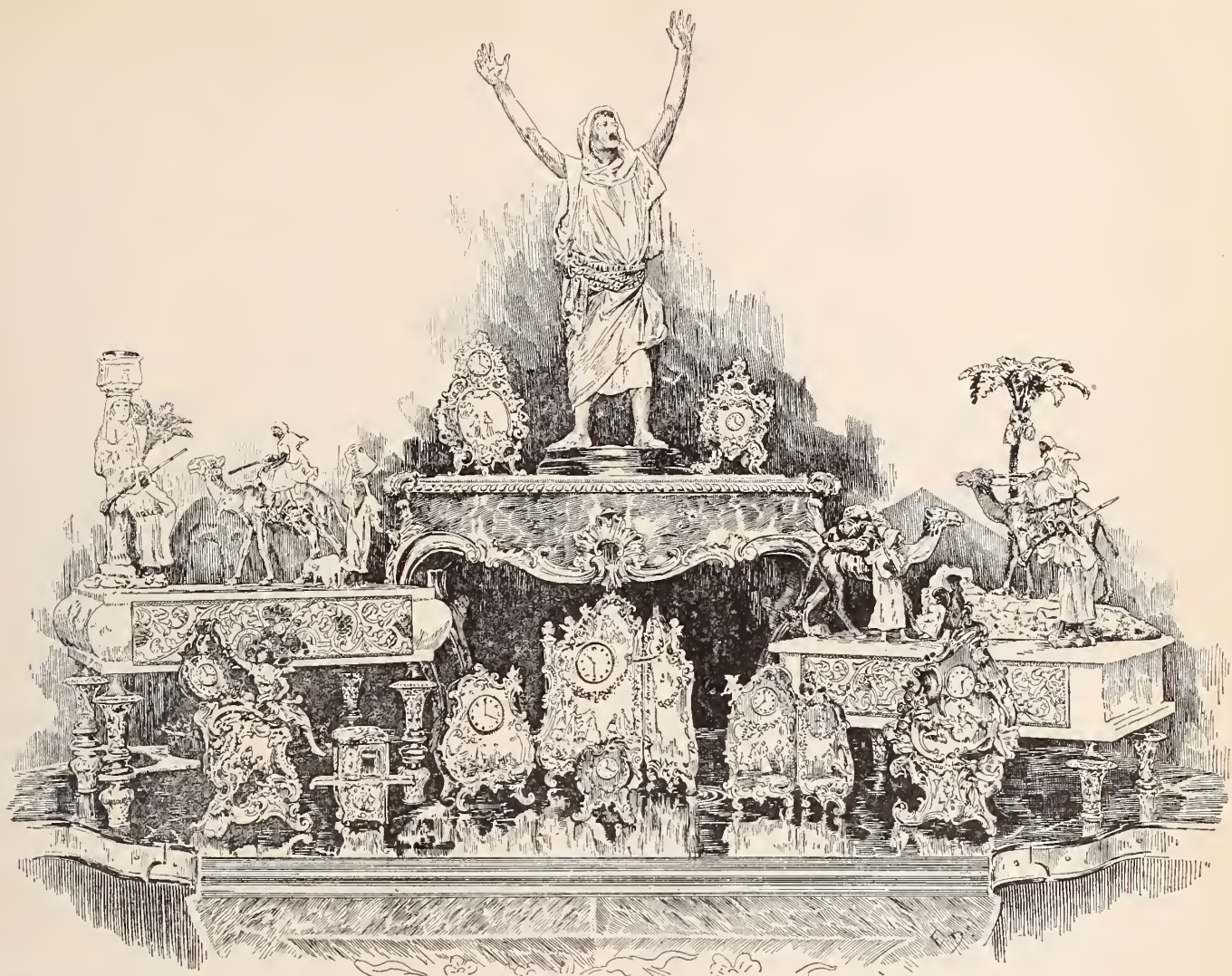

It will greatly interest *Jewelers* and dealers in *Bric-à-Brac*, to see our various assortments of *Fine Art Novelties* which we have imported especially for this trade.

We are very particular to have the *best and latest designs* always in our collections, with the result that we are now showing the *most complete and attractive line of goods ever put on the market*.

Special attention is directed to

VIENNA BIJOU CLOCKS, in exquisite gilt frames of rococo pattern.

VIENNA BRONZES, original in design, perfect in detail.

JEWEL CASKETS, onyx with cloisonné effect.

## SILVER FILIGREE JEWELRY,

comprising many very effective styles in Scarf, Lace and Hair Pins, Brooches and Breast Pins, Bracelets, Bon Bonnières, Match Boxes, etc., etc., at prices which insure a ready sale with a good profit.

---

# GEO. BORGFELDT & CO.,

18, 20, 22 WASHINGTON PLACE, Cor. Greene St.,

NEW YORK.



**The Other Side of Life.**

The man who gets stuck on a paste diamond is not necessarily an Irishman just because he wears a sham rock.—*Judge.*

CALLING HER DOWN.

THE DAUGHTER—O, I saw the strangest piece of jewelry down town this morning. What do you suppose it was?

THE MOTHER—A gold thimble, probably. That's the only piece of jewelry you wouldn't recognize.—*Truth.*



GENERAL LORD FITZ-GORE (of Her Majesty's troops in South Africa).—Your Chief having shown his good will towards Her Majesty's armies, I am commissioned by Her Majesty the Queen to pin this Order of the Bath upon his noble breast.

If "bread is the staff of life," 'tis plain That bread-and-butter's a gold headed cane. —*Puck.*

A QUEEN'S JEWELS.

"My queen!"

It was young Mr. Kilduff who spoke, and he addressed Miss Mullins, at the same time placing his arm around her waist and attempting to deposit a kiss upon her lips.

This was all proper enough, for the two were engaged, and had been betrothed for a year; but the girl evaded the salute, disengaged herself from his embrace, and stood erect.

"I am not your queen!" she replied, with stately, if not regal dignity.

"Why, what's up, Carrie," asked the young man, in surprise.

"You call me your queen. You have often called me that, but I am not. I have read that when Queen Victoria appears in the drawing room it is no uncommon thing to see her display \$750,000 worth of jewelry. How much jewelry do I display? Not even an engagement ring!"

And she held out her ringless fingers for inspection.

Mr. Kilduff caught hold of the extended hand, and this time he got his kiss, for he replied:

"I can't give you as many jewels as Queen Victoria wears, but my queen shall have a diamond ring to-morrow."—*Puck.*

The pickpocket doesn't believe in keeping a watch on his victim. That is, not if he can get it off.—*Philadelphia Record.*

HAROLD—Your clock is fast, Cholly.  
CHOLLY—Yahs, it's a French clock, don-cherknow.

"Augusta, are the eggs boiled?"  
"No, ma'am, they haven't been put to boil yet. I haven't a clock to go by."  
"But there is one in the kitchen, isn't there?"  
"The signora has forgotten that it is five minutes too fast."—*L'Eco del Carrione.*



(And in his access of patriotism the General overlooked one of the peculiar features of the Chief's uniform.)—*Puck.*

**R., L. & M. Friedlander,**



IMPORTERS OF  
**DIAMONDS.**

WHOLESALE  
**JEWELERS.**

JOBBERS IN  
**American Watches.**

Tools, Materials, and Optical Goods.

Send for Catalogue.

65 & 67 Nassau Street, New York.

**Enterprising Jewelers Catch On!**



**Jewish Sheckel, Masonic Mark or Pocket Piece.**  
THE LATEST AND BEST SELLING NOVELTY.

The mark is struck in coin silver; by using either the obverse or reverse of the coin, the back being the same in either case, and permitting of the purchaser's name, blue lodge, chapter and individual mark, with date of same being engraved thereon, as shown in cut above.

Price, without engraving, ONE DOLLAR. Engraved Mark, Dates, etc., 75c. EXTRA.  
Liberal Discount to the Trade.

**CHAS. G. WILLSON, MANUFACTURING JEWELER, READING PA.**

Send for Samples.

**Easter Gifts,**

Prayer-Book Marks, Spoons,  
Letter Openers, Button Hooks  
and all the latest in **STERLING SILVER NOVELTIES.**

MANUFACTURED BY  
**CODDING BROS. & HEILBORN.**

North Attleboro, Mass.  
Chicago office, Buck & Hall, 103 State St., Rm. 802.  
New York office, C. A. Vanderbilt, 178 B'way.



# HINRICHS & CO.,

29 AND 31 PARK PLACE,  
NEW YORK.

## BRIC-A-BRAC and ART POTTERY.

Doulton, Worcester, Royal Vienna, Teplitz, Dresden, Sèvres, Coalport, Austrian Faience, Bisque Figures and Candelabras.

BOHEMIAN AND FRENCH CHRYSANTHEMUM VASES  
and Bouquet Holders, Atomizers, Cologne Bottles and Jewel Boxes.



### SPECIALTIES IN LIMOGES CHINA.

A. D. Cups and Saucers, Chocolate Cups, Teas and Coffees, Mustache Cups, designs and decorations entirely new and exclusively our own.

OUR SPRING STOCK was never more complete than now, and we never had a finer line of goods. Catalogues and Price Lists on application.



## AMERICAN SYNDICATE OF Jewelers' Auctioneers.

ESTABLISHED for the sole purpose of conducting sales for established Jewelers in the United States, Canada and Mexico. We do not sacrifice your goods. We take no sales on a percentage. Our terms are strictly one-half the profits realized on all goods sold. We guarantee you against any loss. We pay all our own expenses; we don't ask you to pay one cent of expense on our account. We buy stocks complete as well as sell them. If your stock is small, or your assortment is not complete, we will furnish from one to ten thousand dollars worth of any kind of stock you may need and in which you need not invest one penny. Don't make any arrangements with others until you read our pamphlet which we will send you free, giving you full particulars of our style of doing business, and the liberal offers we make to Jewelers. We don't care how small your stock is, we will furnish all the stock you need to make a successful sale. We challenge the world for any fairer or more liberal propositions than we make Jewelers. Don't fail to send us your address, and we will send you our business pamphlet, which gives you full explanations as to our terms and style of doing business. Address,

### AMERICAN SYNDICATE OF JEWELERS' AUCTIONEERS.

Offices: { 20 WEST 14th STREET, NEW YORK.  
611 PENN AVE., WASHINGTON. D. C.

### CAMPBELL-METCALF SILVER CO.



2 Maiden Lane, N. Y., with Holmes & Edwards Silver Co. 66 Stewart St., Prov., R. I. Mills Bldg., San Francisco, 8th Floor, Room 1.

## "Old English"

Coffee Spoon.

\*\*\*



DESIGN PATENTED.

Towle Mfg. Co.,

MANUFACTURERS OF

STERLING SILVERWARE.

NEWBURYPORT: No. 214 Merrimack St. CHICAGO: Nos. 149 & 151 State St.

## ONE TRIAL

OF OUR WORK ON REFINING OF  
ALL KINDS WILL CONVINCING YOU  
THAT OUR RETURNS ARE THE BEST.

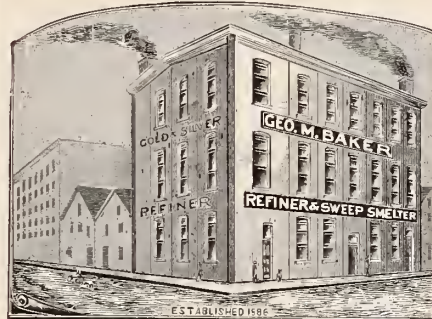

CONVINCE YOURSELF.  
**GEO. M. BAKER,**  
Gold & Silver Refiner  
and Sweep Smelter,  
PROVIDENCE, R. I.

**PATENTS** SECURED WITHOUT  
FAIL OR DELAY.  
Send Rough Sketch or Model and I will tell you  
whether you can obtain a patent,  
WITHOUT CHARGE.  
Fifteen years' experience. Ample references. Address  
**C. T. BELT,**  
WARDER BUILDING WASHINGTON D. C.



AMERICAN RAILWAY SUPPLY CO.  
24 Park Place, NEW YORK.



**M. L. READ & CO.,**

161 DORRANCE ST.,  
PROVIDENCE, R. I.

THE  
Old  
Reliable  
House

FOR  
STICK PINS AND  
WHITE STONE GOODS

**FANCY DIALS** TO FIT AMERICAN WATCHES.  
**\$6.00 per doz.** IN FLAT SECONDS.  
**\$7.20 per doz.** IN PRESSED SECONDS  
Jobbers, Importers and Retailers generally, will be re-  
bated by sending to us any Dials of our make which they  
may have on hand.  
O'HARA WALTHAM DIAL CO., Waltham, Mass.



# Pearl Necklaces

**M. D. ROTHSCHILD,**

NEW YORK: 41 & 43 MAIDEN LANE

LONDON: 15 HOLBORN VIADUCT

PARIS: 58 RUE LAFFITTE.



Elk, Shrine and Masonic  
Emblems a Specialty.

Badges of Every Known Order.

G. A. SCHLECHTER,

Manufacturing Jeweler.

READING, PA

For **BADGES AND MEDALS.**

Flag Pins, Class Pins, Class Rings  
and Special Work of all Descriptions.

SEND TO **E. R. STOCKWELL,** MANUF'R.  
19 John Street, New York

# Sapphires.

**E. KIPLING,**

182 Broadway, New York.

ELEVATOR ENTRANCE, 2 JOHN ST.

## S. F. MYERS & CO.,

WHOLESALE JEWELERS,

MYERS BUILDINGS, - - NEW YORK.

1894 ISSUE, No. 38,

### OUR ROYAL CATALOGUE

Illustrates all that is new, unique and desirable in  
everything that pertains to jewelry.

Sent free to dealers who have not received it.

TWENTY-TWO DEPARTMENTS.

SEVEN DOUBLE FLOORS.

Myers Buildings, 48-50 Maiden Lane,  
33-35 Liberty St., New York.

## S. P. HOWARD,

Gold and Silver Assayer.

**Refiner and Sweep Smelter,**

33 MAIDEN LANE, NEW YORK.

Smelting and Refining Works,

28 & 30 Cumberland Street, Brooklyn, N. Y.

Specialties: Sweepings, Gold, Silver and Platinum

FRENCH ENGLISH  
CLOCKS AND HALL CLOCKS AND  
MATERIALS. MATERIALS

**CHAS. JACQUES CLOCK CO.,** 22 CORTLANDT ST., N. Y.

## L. LELONG & BRO.,

GOLD AND SILVER

**Refiners, Assayers AND Sweep Smelters,**

◁ SOUTHWEST CORNER HALSEY AND MARSHALL STREETS, ▷

**NEWARK, N. J.**

**SWEEPINGS A SPECIALTY.**

## J. SCHAWEL & CO., 29 John St., N. Y

GOLD & SILVER REFINERS, ASSAYERS & SWEEP SMELTERS.

**STERLING SILVER, 925/1000 FINE IN SHEET AND WIRE.**

Soft Platinum, Sheet and Wire for Manufacturing Jewelers.

**A.W.C.CO**

# AMERICAN WATCH CASE Co.,

MANUFACTURERS OF GOLD CASES.

11 JOHN ST., NEW YORK.

FOR THE RETAIL TRADE.

## WM. BIRMINGHAM & CO.,

MANUFACTURERS OF

All Kinds of Leather Spectacle and Eye Glass

**CASES,**

728 Arch Street, PHILADELPHIA, PA.

## J. PRINCE,

Jewelry Auctioneer,

At liberty from January 1st. 1894. Retail

Jewelers only. Address,

Rooms 9 & 10, 137 BROADWAY  
N. Y. CITY.

# ALBERT LORSCH & Co.,

37 MAIDEN LANE, NEW YORK.

Branch, 167 Weybosset Street, Providence, R. I.

— IMPORTERS OF DIAMONDS, —

Rose Diamonds, Rubies, Sapphires, Emeralds, Opals, Moonstones,

Fancy and Imitation Stones, Novelties.

..... SOLE OWNERS AND IMPORTERS OF

*The Sumatra Gem.*

REG'D. UNEQUALLED IN  
BRILLIANCY AND  
HARDNESS

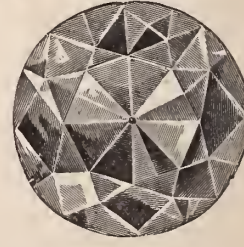
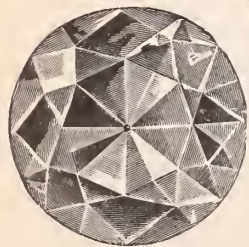

HIGHEST AWARD AT THE COLUMBIAN EXPOSITION, CHICAGO, 1893.

**IT PAYS** TO KEEP IN TOUCH WITH TRADE AFFAIRS.  
THE JEWELERS' CIRCULAR, For 4c. a Week will do it. **Subscribe.**

1869-1894=Twenty-five Years  
Oldest, Best  
Brightest, Newest, =The Jewelers' Circular.





# THE JEWELERS' CIRCULAR

AND HOROLOGICAL REVIEW.

Copyright by THE JEWELERS' CIRCULAR PUB. CO.

189 Broadway, New York.

Entered at the Post Office in N. Y. as second-class matter.

VOL. XXVIII.

NEW YORK, WEDNESDAY, MARCH 28, 1894.

No. 8.

## GREEK ART IN SILVERSMITHING.

A NOTABLE work in silver, of which an illustration made from a crude drawing appeared in THE CIRCULAR some weeks ago, is the beautiful Sage testimonial just completed by Tiffany & Co., New York. The vase, which stands 18 inches high served as a present by the trustees of Cornell University to Henry W. Sage, on the occasion of his eightieth birthday. Its weight is 132 ounces. The designer, Jas. H. Whiteside, celebrated for his famous Bryant vase, has in the piece illustrated herewith, graphically told the story of Mr. Sage's many gifts to Cornell University.

The beautiful figure of Generosity, which stand out in bold relief, with outstretched arms, calls attention to the Sage Chapel, the Cornell Library, and the endowment of the School of Philosophy. The first three are represented by copies of the buildings, and the last is symbolized by the introduction of the Greek Temple of Theseus, with a simple scroll on which is placed the one powerful word, Philosophy. Running in and out and encircling all these is the ivy wreath of friendship. All the work which lies back of the figure, is very artistically etched.

The reverse side bears the description: "Presented to Henry W. Sage on his 80th birthday, Jan. 31, 1894, by former and present trustees of Cornell University, over whom, as Chairman of the Board he has presided for almost 20 years, as a mark

of their esteem and affection for the man and of their grateful appreciation of the

devoted love, the wise and zealous service, and the munificent gifts which he has lavished upon the University."

Each shoulder of the vase bears the head of Minerva. Around the neck and forming with the oak leaves a border, is the quotation: "On earth there is nothing great but man; in man there is nothing great but mind." Around the lower and narrow part of the piece is a band on which is the verse: "Glory to God in the Highest, and on earth peace, good will toward men."

### The Oriental Jeweler.

IT is one of the unexplained mysteries of Asia that the achievements of its best metal workers, so long as their work is useless, should be so completely beyond rivalry. We can understand this as regards the setting of precious stones, for many years ago, the instinct of a southern Asiatic living in painful sunlight is to blend the bright colors he works in till they do not hurt the eye. Consequently the enameller of Jeypore, though he uses flakes of ruby and emerald, produces a surface which looks, even in sunlight, absolutely cool. But what helps him or a Japanese, or even a Turk, if a sultana has given the order, to make a gold or silver ornament which the West can only gaze at in defeated admiration, is still a problem not completely solved.

The Asiatic does not know anything par-



THE SAGE TESTIMONIAL.—MADE BY TIFFANY & CO.



# DEITSCH BROS.

7 EAST 17TH ST., NEW YORK.

## LEATHER GOODS.

EBONY AND SILVER COMBINATIONS.

ORIGINATORS [AND  
[MAKERS OF

NOVELTIES IN  
LEATHER AND  
STERLING SILVER  
COMBINATIONS.



\*\*\*\*\*

**CROSS & BEGUELIN,**

17 MAIDEN LANE, NEW YORK,

ALL GRADES OF  
SWISS AND AMERICAN WATCHES, DIAMONDS,  
GOLD AND ROLLED PLATE JEWELRY, OPERA  
AND FIELD GLASSES, TOOLS AND MATERIAL.

SOLE AGENTS FOR THE  
**Rockford Watch Co.**  
MANUFACTURERS OF THE  
**Centennial Watches.**

SEND FOR OUR WATCH MATERIAL AND TOOL PRICE LIST FOR 1894.

\*\*\*\*\*

### AMERICAN SYNDICATE OF Jewelers' Auctioneers.

ESTABLISHED for the sole purpose of  
conducting sales for established  
Jewelers in the United States, Canada  
and Mexico. We do not sacrifice your  
goods. We take no sales on a percent-  
age. Our terms are strictly one-half the  
profits realized on all goods sold. We  
guarantee you against any loss. We pay  
all our own expenses; we don't ask you  
to pay one cent of expense on our ac-  
count. We buy stocks complete as well  
as sell them. If your stock is small, or  
your assortment is not complete, we  
will furnish from one to ten thousand  
dollars worth of any kind of stock you  
may need and in which you need not in-  
vest one penny. Don't make any arrange-  
ments with others until you read our  
pamphlet which we will send you free,  
giving you full particulars of our style of  
doing business, and the liberal offers we  
make to Jewelers. We don't care how  
small your stock is, we will furnish all  
the stock you need to make a successful  
sale. We challenge the world for any  
fairer or more liberal propositions than  
we make Jewelers. Don't fail to send us  
your address, and we will send you our  
business pamphlet, which gives you  
full explanations as to our terms and  
style of doing business. Address,

### AMERICAN SYNDICATE OF JEWELERS' AUCTIONEERS.

20 WEST 14th STREET, NEW YORK.  
Offices: 611 PENN AVE., WASHINGTON, D. C.

## "THE BEST BUTTON MADE."

THE KREMENTZ

IN GOLD

IN ROLLED PLATE

FROM  
KREMENTZ & CO.



ONE PIECE

FROM  
ALL JOBBERS'

### COLLAR BUTTON.

IS THE ORIGINAL ONE PIECE BUTTON.

IS STILL THE BEST AND STILL UNSURPASSED.

Sold by all whole-  
sale dealers at manu-  
facturer's price.

**A. N. CLARK,**  
PLAINVILLE,  
CONN.

### Manufacturer of the Celebrated LOOP WATCH KEY.

The Best for the Price in the World.  
CROSBY'S JEWELING TOOLS IMPROVED.

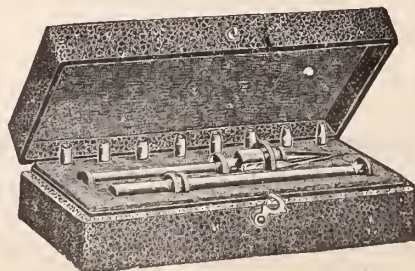
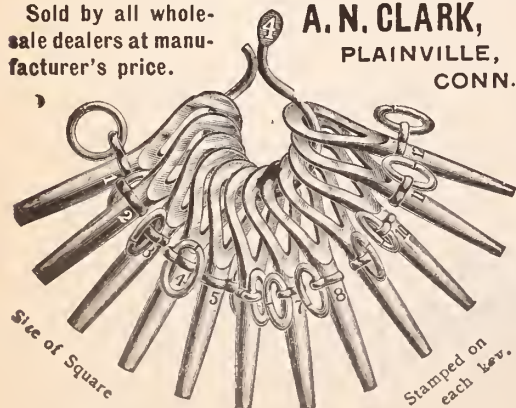

### CAMPBELL-METCALF SILVER CO.

Choice  
Concepts  
IN

Sterling  
Silver  
ONLY.

2 Maiden Lane, N. Y., with Holmes & Edwards Silver  
Co., 66 Stewart St., Prov., R. I. Mills Bldg., San Fran-  
cisco, 8th Floor, Room 1.



Will quote royalty or price for the manufacturing of articles of real worth.



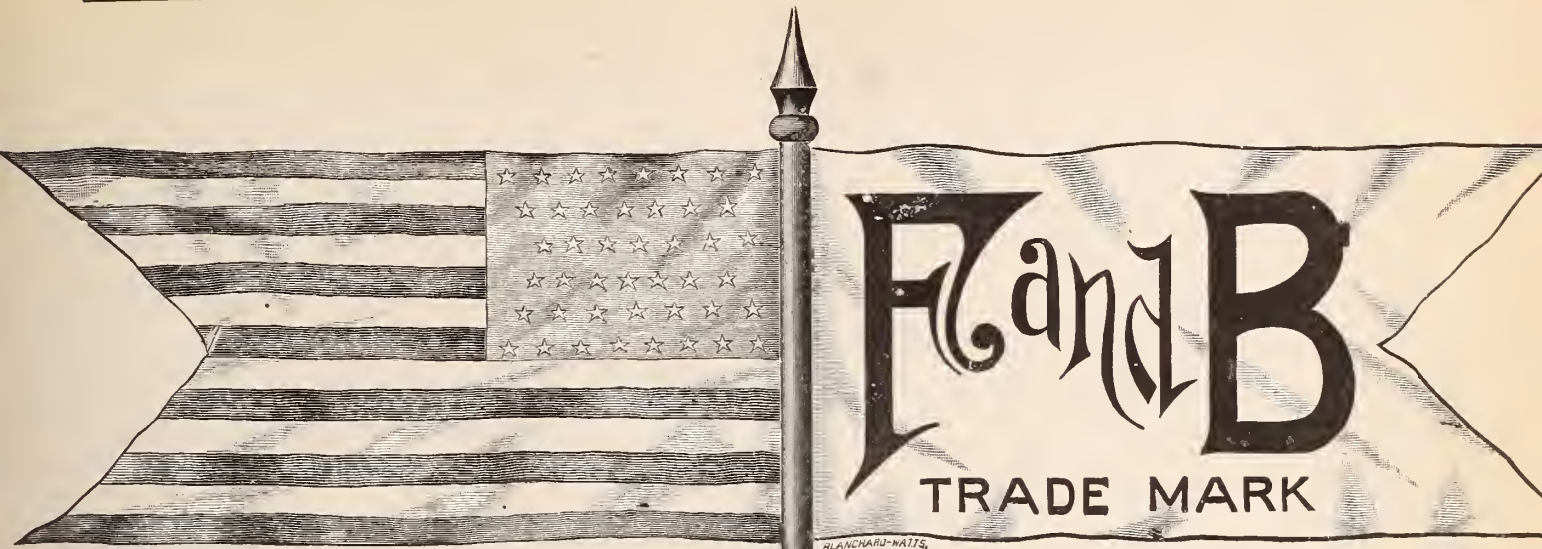

**Our American F. & B.  $\frac{1}{10}$  Gold Chains will assay 10 K. 1-10 gold, and are guaranteed for ten years.**

**Our regular line of Chains is made of heavy gold plate, finely finished, and guaranteed for five years.**



**Chains**  
Our new line of chains will assay 10 karat 1-10 gold. All gold soldered.  
**American F. & B. 1-10 gold.**

**WE RECEIVED 4 MEDALS AT THE WORLD'S FAIR.**

**Mount Hope Button.**



**CLOSED.**

<p><b>Watch Chains for Gentlemen</b></p> <p>These goods are of fine quality, and guaranteed to give satisfaction. Some recently added have sold far beyond expectation. They are made of heavy rolled plate in all sizes and patterns.</p>	<p><b>Watch Chains for Ladies</b></p> <p>Our Victoria and Princess chains are neat and pretty. They are made in all bright, Roman and bright, platinum and bright gold, and have one or two charms.</p>
--	---

**Mount Hope Button**

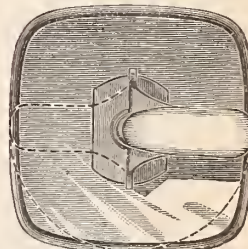



**OPEN.**

<p><b>Charms</b></p> <p>This line is adapted to ladies' or gentlemen's chains, and includes a number of heart charms in Roman, bright and satin finish, with stones and without.</p>	<p><b>Hair Chain Mountings</b></p> <p>In solid gold and rolled plate. We are headquarters and make everything desirable in this line.</p>	<p><b>Bracelets</b></p> <p>We make a large stock of curb bracelets in five sizes, besides the graduated links, with padlocks and snaps, in chased and plain polished, Roman, rolled silver plate and sterling silver. Also padlocks with keys and a push snap.</p>
--	---	--

<p><b>Pins</b></p> <p>Our large line of lace and cuff pins comprise many desirable patterns in gold fronts engraved and trimmed. Also includes baby pins and scarf pins.</p>	<p><b>"Mt. Hope" Buttons</b></p> <p>These are superior to any button in the world. They are easy to put in and easy to take out of the cuff.</p>	<p><b>Link Buttons</b></p> <p>This line has increased rapidly with us, and is very low in price, embracing all styles in Roman, chased, engraved and plain, with and without stones, and some in enamel.</p>	<p><b>Crosses</b></p> <p>We make four sizes of gold filled in plain, engraved and set with stones, and suitable for our neck chains.</p>
--	--	--	--

<p><b>Sterling Silver and Solid Gold Sword Scarf Pins</b></p>	<p><b>Glove Buttoners</b></p> <p>We make the interlocking and one with a twist handle in gold rolled plate and silver rolled plate.</p>	<p><b>Earrings</b></p> <p>This line includes many pretty patterns in gold fronts engraved, some with pretty trimmings and a small line of hoop drops.</p>	<p><b>Neck Chains</b></p> <p>We make a variety of neck-chains in bright and Roman, with snaps.</p>	<p><b>Sterling Silver Bracelets and Padlocks</b></p>
---	---	---	--	--

	<p><b>Gold Lockets Set with Diamonds</b></p> <p>These locket are made of 10 karat gold throughout and set with brilliant diamonds. They cannot be surpassed in finish or cheapness of price.</p>	<p><b>Gold Lockets Engraved</b></p> <p>These locket are also made of 10 karat gold throughout, with beautiful designs engraved thereon and the price is so low that they cannot fail to be in great demand.</p>	<p><b>Gold Front Lockets</b></p> <p>This line is very extensive. Many patterns are plain polished, others nicely engraved, with and without stones.</p>	<p><b>Rolled-Plate Lockets</b></p> <p>This line is almost endless, and consists of nearly every conceivable shape, size and style. Some are set with imitation diamonds, rubies and sapphires.</p>	
---	--	---	---	--	---

**We have put upon the market a line of Gentlemen's Chains and Ladies' Chain Bracelets made of 1-10 gold stock. Every joint is soldered with gold, and every Chain or Bracelet will assay more than 1-10 gold. They are our AMERICAN F. & B. 1-10 GOLD goods, and are so stamped. Bar, Chain and Swivel are stamped 1-10 gold.**

**FOSTER & BAILEY, Providence, R. I.**



ticular about gold and silver; he has no tools except pincers and a hammer; and he has not the power of producing intense heat; yet he will do things with the metals which his European brother cannot do with all his appliances and skill. No doubt, if he is an hereditary workman, something has passed into his fingers which cannot be acquired by a new competitor, and he has the advantage of remembering patterns originally designed by the men of genius, who are apt, at intervals perhaps of centuries, to crop up in the artist families; but is that the whole of the matter? We doubt it greatly, and believe that there is an Asiatic "taste" or instinct for the beautiful which is as true in its way as the instinct of an Athenian sculptor or a Florentine wielder of the brush.

It takes a different direction—we see that most perfectly when we compare the Alhambra with a Gothic cathedral—and it seems liable to strange long pauses, like the one said to have been recently observable in Japanese art; but is real, it is original, and we can see no reason, save want of demand, why it should ever die out. If that is true—and it must be true, more or less—and Europe can ever use the Asiatic fingers without taking the skill out of them in the collision between the tastes of the two races, the jeweler of Birmingham may justifiably begin to tremble. Machinery will not help him much, and the "superior energy" of the British workman will not help him at

all. Energy is not the quality wanted to produce a necklet or a ring. What is wanted is a gift the Asiatic workmen in thousands did once possess, and may display again, and the power of so utilizing that gift that it shall manifest itself even when the designs are not stereotyped in the mind, but have been freshly taken in.—London *Spectator*.

**Bids for Furnishing the Government with Anemometer Registers.**

WASHINGTON, D. C., March 21.—Proposals were opened March 15th, at the Signal Office, for furnishing the Signal Service with registers, specifications of which were published in a recent issue of THE CIRCULAR. The bids were as follows:

F. Kroedel & Son, New York, N. Y., anemometer register with phonograph fly back without stopping clock movement, with Howard railroad clock, 13 jewels, lever movement, battery, etc., in first-class workmanship, for \$65. Nine more at \$60 each. Same with Seth Thomas railroad clock, plane jeweled, lever movement, \$5 each less. The anemometer registers will be horizontal, and the stop will be on the bottom of the disk.

Queen & Co., Philadelphia, Pa., the register to be 6½ inches in diameter, case of first quality brass. The workmanship first-class throughout. The clock movement to be Seth Thomas chronometer lever No. 5,003,

to be made to work continuously or to stop when lever is pressed. To be encased in polished wood box. Price for one, \$25; price for nine more \$23 each, or register as present sample but with specified clock movement, first quality brass case and first-class workmanship for \$25. Price for nine more, \$23. To be furnished in 60 days.

Julien P. Friez, Baltimore, Md. Nine registers, for the lot \$1,575. This estimate includes special cases. Without special cases at a reduction of \$6.25 from each. Price of sample alone as it stands, \$437.50. To be furnished within 90 days.

**Further Resolutions in Honor of the Late Andrew Paul.**

At a special meeting of the Executive Committee of the National Association of Jobbers in American Watches, recently held, the following action was taken:

WHEREAS, Our fellow-member, Mr. Andrew Paul, of Boston, who had been associated with us on this committee for a number of years, has been removed by death. Now, therefore,

*Resolved*, That we hereby record our deep regret that the pleasant relations which have existed between us have thus been severed, and our appreciation of the conscientious and painstaking care with which he fulfilled his duties as a member of this body.

*Resolved*, That we tender our hearty sympathy to the family and friends thus suddenly bereaved, and to his business associates in being deprived of a representative who was ever mindful of their best interests; and,

*Resolved*, That a record of this action be made upon our minutes, and that copies of the same be sent to the family and to the trade papers.



**MATHEY BROS., MATHEZ & CO.,**

21 & 23 MAIDEN LANE, N. Y.  
BRASSUS, SWITZERLAND.

Manufacturers and Importers of  
Plain and Complicated  
WATCHES.

**SPLITS**  
A SPECIALTY.



Sole Agents for **Jaques Lecoultré Razors.**



**M. L. READ & CO.,**

161 DORRANCE ST.,  
PROVIDENCE, R. I.

THE  
Old  
Reliable  
House

FOR  
STICK PINS AND  
WHITE STONE GOODS

**NEW CLOCK STAFF WRENCH.**



This entirely new and most useful tool is for setting up clocks, particularly fine and costly ones. Can remove pivots at ease. No chance of displacing other pivots in the operation. For description, send 5c. in stamps for catalogue of over one thousand varieties of fine tools.

O. W. BULLOCK & CO., Springfield, Mass.

WHITE'S EYE SHADE. **W. B. WHITE & SON**  
MANUFACTURERS OF



Spectacle and Eye Glass  
CASES

90 SOUTH STREET, BOSTON.

Special Cases made to order for Optical Trade. Cases for Trial Lenses. Opera Glasses recovered, etc. Chatelaine Spectacle Cases, Metal Bound Leather Cases for combs, scissors, etc. Over forty kinds of cases manufactured.



THE *Pairpoint*

MFG. COMPANY,

o o o o

MAKERS AND DESIGNERS OF

FACTORIES:  
New Bedford,  
Mass.

"HIGHEST GRADE"

Gold & Silver Plate

WE ALWAYS CARRY IN STOCK

A LARGE LINE OF

**RICH CUT**  
o o o o **GLASS**

... AND ...

Decorated Art Wares.

Jobbers o o

You make no mistake in ordering a line of

"PAIRPOINT"

Hollow & Flat Ware



No. 4907. SMOKING SET, GOLD LINED.

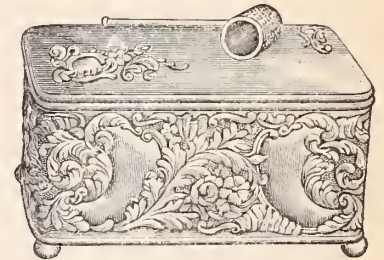

No. 2764. TOBACCO BOX.



No. 944 EMBOSSED JEWEL BOX, SATIN LINED.

SALESROOMS:

NEW YORK, - - - 20 Maiden Lane.  
CHICAGO, - - - 224 Wabash Ave.  
SAN FRANCISCO, - - - 220 Sutter St.

**A. J. LOGAN,**

MANUFACTURER OF  
WATCH TOOLS, HAIR SPRINGS AND  
**WATCH MATERIALS.**

< New Catalogue just issued, Sent on Application. >  
WALTHAM, MASS.

**CROUCH & FITZGERALD.**

Jewelry Trunks  
and Cases,  
161

Broadway,  
Bet. Cortlandt and  
Liberty Sts.,  
688 B'way,  
701 6th Ave.,  
NEW YORK.



**PATENTS SECURED WITHOUT  
FAIL OR DELAY.**

Send Rough Sketch or Model and I will tell you whether you can obtain a patent, WITHOUT CHARGE.  
Fifteen years' experience. Ample references. Address

**C. T. BELT,**  
WARDER BUILDING WASHINGTON D. C.

**Jules Jürgensen**  
OF COPENHAGEN.

The reputation these watches have maintained for **Fifty Years** has never been equalled, being made on strictly scientific principles and no expense spared to give the **Best** results in mechanism and timekeeping qualities.

SOLE AGENTS.

**John C. Hyde's Sons,**  
NO. 22 MAIDEN LANE.

We sell to the legitimate Jewelry and Stationery trade only.



NEW YORK CITY U.S.A

**CHOICE PAPERS**

MAKERS OF

**FINE STATIONERY**

For Correspondence, Wedding and Business Use, handsomely boxed, specially suited to the Jewelry Trade.

18 MURRAY STREET, NEW YORK.



# R. WALLACE & SONS MFG. CO.

SILVERSMITHS

Trade Mark.

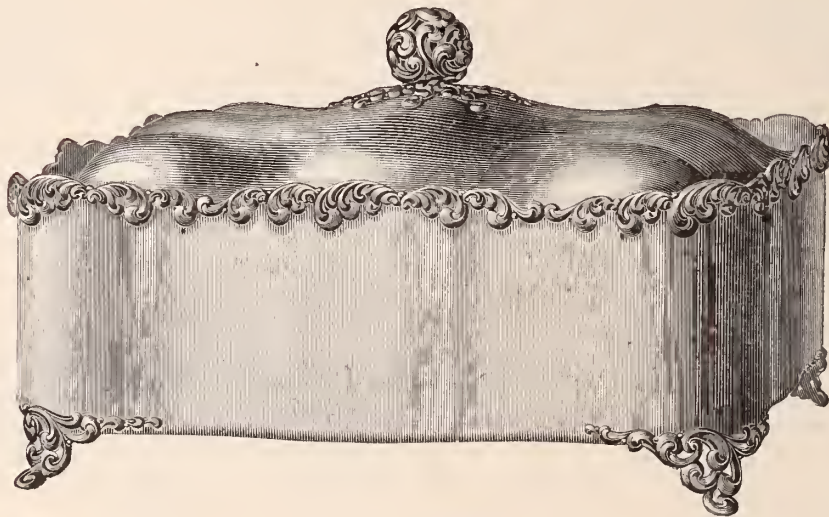

WAVERLEY SARDINE BOX.

Manufactories and  
Main Office,

WALLINGFORD, - - CONN.

BRANCHES :

NEW YORK  
3 PARK PLACE.

SAN FRANCISCO,  
120 SUTTER STREET.

CHICAGO  
86 WABASH AVENUE.



**Jewelers of Nebraska Determined to Fight Trade Abuses.**

BEATRICE, Neb., March 18.—The officers elected at the meeting of Nebraska jewelers, held March 14 and 15, to form a mutual-protective association, details of which were given in THE CIRCULAR last week, were as follows:

President, Richard O'Neill, Lincoln; vice-president, Fritz Hoefler, Aurora; secretary, F. A. Hannis; treasurer, John Baumer, Omaha. The board of directors will be composed of the officers of the association and the following associates: C. B. Coffin, Ord; Geo. Arkwright, Beatrice; E. A. Polley, Seward.

The jewelers came from all parts of the State, at much sacrifice of time and money. It is evident that a determined effort will be made to close at least some channels that are an outrage to the common rights of the retail jewelers.

**Incorporation of an Advertising Clock Concern.**

SAN FRANCISCO, Cal., March 22.—The California Clock Advertising Co. have incorporated with a capital stock of \$100,000 in single shares of \$1 to "own, operate and manufacture, and deal in combination advertising clocks, and do an advertising business."

The incorporators are: Louis A. Robertson, H. Hogrove, Max Wiesenhutton, J. P. Richardson and I. C. Gainey, San Francisco, Cal.

**A Daring Texan Attempts to Rob a Jewelry Store.**

GREAT FALLS, Mon., March 21.—A man on a horse stopped in front of the jewelry store of Sam Herskovitz this week, and after asking a bystander to hold the horse, walked in. He said quietly to the proprietor as he drew two big revolvers: "Open that safe, and do it quick."

Mr. Herskovitz being alone did not stop to argue the case, but opened the safe and began to count out the cash. A chance passer-by happened to look through the window, saw the predicament of the jeweler, and called a policeman, who, slipping quickly in, covered the daring robber, who gave up, remarking:

"You have the advantage of me, partner. If you hadn't I would have got you too." The man gives his name as Thomas Wegnor. He has been stopping for two weeks at the Milwaukee House, registering from El Paso, Tex.

Henry Hoegelsberger, Wilmington, Del., will put in a line of jewelry in connection with his optical business.



**THE BOWDEN SEAMLESS RING**

IS MADE ONLY BY

**J. B. BOWDEN & Co.,**

Makers of Finger Rings of every Description.

**COR. BROADWAY & JOHN STREET, NEW YORK.**

**\$3.00**      **FORMERLY**      **\$6.00**

Ivory and Enamel Miniatures

Best Workmanship.



Original Inventor and Patentee of Miniatures —OR— Gold and Silver.

PATENTED November 12, 1889.

**LEON FAVRE, 107 E. 26th Street, New York.**

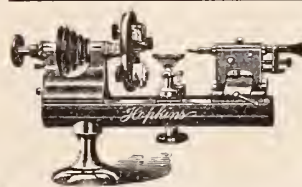

Prices of LATHES AND CHUCKS are "WAY DOWN"

All purchasers of our THREE FOUR lathes and chuck combinations now receive FREE our new TIP OVER "T" REST, on which we have patent pending. The most valuable addition to plain lathe in recent years.



SEND FOR FEB. PRICE LIST.

WALTHAM WATCH TOOL CO., SPRINGFIELD, MASS



The Roy Watch Case Co. Cases are Sold only through Jobbers.





**G. A. WEBSTER**

42 &amp; 44 Madison St., Chicago, Ill.

**Manufacturer,**

AND WESTERN AGENT FOR

E. G. WEBSTER &amp; SON, of Brooklyn, N. Y.

A. F. TOWLE &amp; SON CO., of Greenfield, Mass.

**HENRY ABBOTT,**

MANUFACTURER OF

**Stem-Winding Attachments****FOR WATCHES,****No. 2 Maiden Lane, NEW YORK.**

DON'T FORGET THE JEWELERS' CIRCULAR PUBLISHING CO.'S BOOK LIST when in want of any technical book in the Jewelry or Kindred Trades.

**Litigation in the Failure of the Philadelphia Optical & Watch Co.**

PHILADELPHIA, Pa., March 22.—Argument was heard Monday on the appeal of the Keystone Watch Case Co. in the case of the Pairpoint Mfg. Co. and others against the Philadelphia Optical & Watch Co. and others, from Common Pleas No. 3, of this county.

On Jan. 10th last and during the succeeding day an attachment for \$25,000 by Chas. C. Harrison, execution by the Keystone Watch Case Co. upon a judgment for \$39,785.93 on a bond and warrant of attorney, and numerous other attachments and executions, were issued against the Philadelphia Optical & Watch Co., and the property of the corpor-

ation was seized by the sheriff and a sale advertised. About a week later the Pairpoint Mfg. Co. and a number of other unsecured merchandise creditors of the optical and watch company filed a bill in equity against the company averring that an application had been made for a receiver for the optical and watch company in the Chancery Court of New Jersey, it being incorporated under the laws of that State, and asking that receivers be appointed in this county.

The Court appointed the receivers, who are James Work and the Guarantee Trust and Safe Deposit Co. The bill in equity averred, among other things, that the judgments were given to the Keystone Watch Case Co. and others "to make preference for the creditors holding the same, to the detriment and damage of the other creditors of the company." On Feb. 16th the receivers petitioned the Court for an injunction restraining the judgment creditors from proceeding with their executions, the sheriff's sale being already advertised and postponed. The injunction was granted, and from this the Keystone Company took appeal.

The question of law involved was chiefly one of jurisdiction, as to whether the case came under the jurisdiction of the Pennsylvania or the New Jersey State Courts. The appellants alleged that they were under the jurisdiction of the Pennsylvania law, and even if they must be ruled by the law of the State of New Jersey, the decisions there justified their position. On the other hand, it was averred that, under the New Jersey law, all the creditors of the corporation must share equally in the assets of the corporation, and not for the amount in which they had been preferred.

At Monday's argument B. H. Lowry appeared for the appellants and Francis E. Brewster and William W. Wiltbank for the American Optical Co., one of the appellee creditors. The Court reserved its decision.

A. E. Pierce, Eldred, Pa., will retire from the jewelry business.

**Removal!**

.....

**J. W. RICHARDSON & Co.**

MANUFACTURERS OF

**Gold Emblems** Have removed to**No. 200 BROADWAY.****NEW YORK.****F. M. WHITING & CO.,**

NORTH ATTLEBORO, MASS.

New York Office,  
857 BROADWAYAFTER MAY 1ST,  
at 1128 BROADWAY  
and 208 FIFTH AVE.

TYROI FAN ALMOND SCOOP, No. 15.

We are continually producing new ideas in

Sterling Silver Hollow Ware, Toilet Articles, Novelties, &amp;c., as well as in Flatware.

Handsome New Catalogue Showing 22 Patterns in Teas, and 36 Patterns in Coffee Spoons, will be mailed on application.

**ROY**

The Roy Watch Case Co. Cases  
assay among the highest.

**ROY**



**One of the Oldest Jewelers in the Country Assigns.**

LYNCHBURG, Va., March 22.—H. Silverthorn, the well-known jeweler, who has been doing business for many years in the store, 912 Main St., has made an assignment, naming lawyer F. W. Whittaker as trustee.

The property conveyed consists of all the stock of jewelry, gold, silver, diamonds, etc., in the store here; the stock held by W. H. Neighbors, of Wytheville, on consignment; debts due the concern; house and lot occupied by the assignor as a residence, corner 14th and Fillmore Sts., fronting on Fillmore 165 feet and running back 264 feet to Floyd, containing an acre, more or less; vacant lot on southwest corner of 14th and Fillmore Sts., fronting 165 feet on Fillmore and running back 132 feet; all household and other furniture or property of every kind belonging to the assignor.

The nominal assets, including the accounts that are supposed to be good, amount to about \$50,000. The liabilities are in the neighborhood of \$30,000. The first class provides for payment of costs of the trust, rent, taxes and amount due employes; second class, claims aggregating \$15,292.75; third class, \$13,202.94. The business will be continued for a year by the trustee, and it is hoped that every dollar of the liabilities can be paid, and Mr. Silverthorn be able to remain in the field after that time.

Henry Silverthorn has been in the jewelry business here for upwards of 50 years, and no merchant stands higher in the public esteem or in the confidence of the trade. It is the general hope that he may successfully tide over his present difficulties.

**Death of Oliver B. Marsh.**

BINGHAMTON, N. Y., March 28.—Oliver B. Marsh died at his home in this city, yesterday morning. Mr. Marsh was a watchmaker and a most skilful mechanic. He was born in Vermont, and went to Newark in 1859. He worked for a time for James M. Durand, and then started in business for himself in a small store, where the Merchants Insurance building now stands. He moved across the way to 775, and remained there until 1876, when he came to this city. He leaves a widow and one son.

**Jeweler Geo. W. Luce Declared to be Insane by a Jury.**

COLUMBUS, O., March 23.—George W. Luce, the jeweler who was arrested nearly a year ago for receiving stolen goods, was this week declared insane by a jury and will be sent to an asylum. The case was submitted without argument and the jury brought in a verdict of insanity in less than ten minutes. It was unanimous. A two-thirds vote would have been enough.

Luce's criminal operations were disclosed by the arrest of two noted burglars and proved to be extensive. Luce is now almost a physical as well as a mental wreck. The indictments against him will not be nolleed, however.

**Fritzie Dhein Sentenced for the Keck Robbery.**

DAYTON, O., March 23.—Fritzie Dhein, diamond thief, known widely all over this country, whose capture was due to the Jewelers' Protective Union, entered a plea of guilty to the charge of grand larceny in robbing a salesman of the Herman Keck Mfg. Co., Cincinnati, and was sentenced to seven years in the penitentiary by Judge Dwyer. The sentence is the limit of the law, and if Dhein lives he will be near fifty years old when he again emerges from the prison walls.

The history of his theft of the Keck diamonds, his indictment for grand larceny and being a habitual criminal, the trial, disagreement of the jury, his flight and capture, are yet familiar to the readers of THE CIRCULAR. It was a new and unexpected turn that took place in the case this week. It was generally understood that he would be tried under both of the original indictments. The disposition of the case was brought about by an agreement between the Court, Dhein's attorneys, the prosecuting attorney and Dhein himself. The arrangement was consented to by the State, on the ground that another trial and proof that he is a habitual criminal would cost the State at least \$2,000, it being necessary to have the attendance of witnesses from Kentucky, New York and other places.

Dhein came into court accompanied by Sheriff Gussler, and attracted but little at-

tention, few in the court room recognizing the noted prisoner, owing to the full beard which now adorns his face. Mr. Nevin, his attorney, stated that Dhein desired to withdraw his plea of not guilty to the indictment pending against him for grand larceny and enter a plea of guilty. The ex-prosecuting attorney who prosecuted the case at the original trial, stated that the indictment charging him with being an habitual criminal would be nolleed. Consent was then given, and the prisoner entered a plea of guilty and received his sentence as above indicated.

**Death of a Well-Known Watchmaker.**

LANCASTER Pa., March 23.—Monday morning about 7 o'clock John M. Hofart, one of Lancaster's oldest and best known watchmakers, died at St. Joseph's Hospital after a lingering illness from cancer of the bowels. Mr. Hofart has lived retired for some time and about three weeks ago he was admitted to that institution, where he slowly passed to rest.

Deceased was born in Germany and was 73 years old. After learning the trade of watchmaking he came to this country and settled in this city. He soon became one of our leading watchmakers and was widely known by the older citizens. No children survive him and he is without a relative in this country.

Aldace Vondett will open a jewelry repair shop in the Kelly block, Rutland, Vt.

**Chrysanthemum.**

WE BEG TO ANNOUNCE THE EARLY APPEARANCE OF THE GREATEST EFFORT IN SPOONS AND FORKS, THE

**Chrysanthemum,**

(DESIGN PATENT PENDING).

FOR A YEAR THE MOST EXPERT DESIGNERS AND DIE-CUTTERS HAVE BEEN ENGAGED ON THE RICHEST AND MOST EXPENSIVE SPOON AND FORK DIES EVER PRODUCED. WE BELIEVE IT WILL BE TO YOUR ADVANTAGE TO INSPECT THE

**Chrysanthemum**

WM. B. DURGIN,  
CONCORD, N. H.

PATTERN BEFORE RENEWING YOUR STOCK OF SILVER.

PATTERN IS NOW IN PROCESS OF ILLUSTRATION.





**Benj. S. Wise & Co. Make Three Offers in Composition.**

A meeting of the creditors of Benj. S. Wise & Co., retail jewelers, 861 Broadway, New York, who on March 20 gave a bill of sale to L. Tannenbaum, of L. Tannenbaum & Co., and several relatives, was held Friday afternoon at the office of Mr. Wise's brother and attorney, Morris Wise, of Wise & Lichtenstein, 52 Exchange place. About 20 creditors were present.

Morris Wise, explaining the reasons for his brother's embarrassment, stated that he had borrowed largely from relatives to meet current expenses, and had greatly reduced his indebtedness, but finding that he could no longer continue had given bills of sale aggregating \$78,000. to L. Tannenbaum & Co. for \$18,000, another to Mr. Tannenbaum, for \$7,000 as indorser of an account owed to Stern Bros. & Co., and the remainder to relatives who had accommodated him with various sums of money. After giving a statement of Mr. Wise's condition, he said his brother was prepared to make any of the following offers: 100 cents in equal installments in 12, 18, 24 and 30 months in notes of Benj. S. Wise and Louis Hein, his former partner; 30 per cent. in four, eight and 12 months in notes satisfactorily indorsed; or 25 cents cash.

The indebtedness had occurred, the attorney stated, while Mr. Hein was a member of the firm and he had not been released from liability at his withdrawal, except by one or two creditors. After some discussion it was unanimously decided to accept any of the offers proposed and Mr. Wise was instructed to go among the creditors for signatures to the same.

Benj. S. Wise stated to a CIRCULAR reporter Saturday afternoon that his offer had been generally accepted. When asked the reason for his embarrassment he said he was \$18,000 short, due to losses, heavy expenses, large salary list and money sunk in his store under the Hoffman House. Mr. Wise gave the following statement of his assets and losses:

Stock at cost including fixtures.....	\$80,000
Outstanding accounts.....	5,000
Net loss for 1893.....	29,000

Total.....\$114,000

He had doubtful accounts of \$2,000 making a gross total of \$116,000. The losses were:

Memorandum goods.....	\$1,000
Rent of store.....	8,500
Salary list.....	9,000
Sundries.....	1,000
Interest accounts.....	5,000
Loss on Long Branch store.....	800
Loss on Hoffman House store.....	4,000
Bad debts.....	3,500
Amt. drawn by both partners.....	10,000

Total.....\$41,300

Deducting \$14,000, the average profit, left a net loss of \$29,000 for 1893.

The total amount paid to creditors on stock was \$78,100. The amount of the unsecured indebtedness held by about 40 creditors is \$18,000. Mr. Wise stated that if his offer was not accepted by all the creditors, the principal creditors would form a stock company to continue the business, making him manager of the concern. He emphatically denied the story that he had stated at the time his partner, Mr. Hein, withdrew, that he was worth \$35,000. He claims that what he did state was that he had \$35,000 in the business borrowed from relatives, which he would not be troubled for and which he would practically consider as capital.

**Death of Edward M. Marshall.**

NATICK, Mass., March 26.—Edward M. Marshall, for many years a prominent jeweler here, died on Thursday last after a prolonged illness from a complication of diseases. The funeral took place to-day from his late residence.

The deceased was a veteran of the civil war, and the Mozart Association (40th Regt., N. Y. Vols.) marched as a guard of honor, escorting the remains to the place of burial. Mr. Marshall was 68 years of age and leaves a widow.

**Wm. B. Morse's Store Again the Scene of a Daring Robbery.**

BOSTON, Mass., March 24.—The show window of William B. Morse's jewelry store, 268 Tremont St., which has been the scene of so many robberies in the past three or four years, was broken last evening by a daring thief who was captured before he could make off with any of the stock in Mr. Morse's display.

A policeman reached the corner nearby just as the thief, who stood with his back to the window and held a brick in his hands, pounded in the glass. While he was tearing away the shivered pieces of glass from the small opening he had made the officer arrived and took him into custody.

The prisoner gave his name as Edward Ducharme, and his age as 30 years. He answers somewhat to the description given of the man who smashed the window of a jewelry store on Court St., just before Christmas, by hurling a brick through the glass, but he may be an imitator of that bold and successful robber. In the municipal court, this morning, Ducharme waived examination and was held for the Superior Court.

August Winkler's jewelry store, Poplar Bluff, Mo., was destroyed by fire March 23.

**The Assignment of John B. Yates.**

John B. Yates, jobber in watches and jewelry, 21 Maiden Lane, New York, made an assignment, Thursday, to John Barker Brown, 167 W. 83d St., giving the following preferences: Crescent Watch Case Co., \$2,000 for merchandise; to the holders of two promissory notes for \$1,000; Geo. W. Yates, senior, the balance due on a certain promissory note for \$2,000; Henry Ginnel & Co., \$1,232 on a note due in four months. Mr. Brown, the assignee, is an importer of teas at 142 Front St.

Mr. Yates has been in business since 1888. He was prior to that time the New York agent of the Trenton Watch Co. A CIRCULAR reporter who called upon Mr. Yates, Friday, found him sick in bed with nervous prostration, which was said to be due to worry over his embarrassment. Mr. Yates stated that his assignment was due to many causes, the principal being the depression in business and the failure of some of his largest customers to renew their contracts with him.

Mr. Yates stated that though he has been doing a large business lately, it was on such a small margin that but little if any profit accrued therefrom. The two \$1,000 notes mentioned in the preferences, he said, were held by N. H. White & Co. He estimated his liabilities roughly at between \$35,000 and \$40,000, and his assets at between \$20,000 and \$30,000. Mr. Yates' principal indebtedness is held by four firms, Seth Thomas Clock Co., Crescent Watch Case Co., N. H. White & Co. and Henry Ginnel & Co.

Mr. Brown, the assignee, stated Monday that he could not yet definitely give any idea of the assets or liabilities. He desired to have his statement ready and call a meeting of the creditors as soon as possible, but how soon this would be he would not say. He declined to give any further information.

Albert H. Gleason, of Hastings & Gleason, Mr. Yates' attorneys, said Monday afternoon that Mr. Yates was suffering from congestion of the spinal cord, and was too ill to be seen by any one. The schedules upon which they were at work would be filed very shortly, provided their client recovered sufficiently to examine them. The attorney stated that the assignment was made on his advice, as Mr. Yates was physically as well as financially incapacitated from bearing the strain any longer.

Kennedy, the new jeweler of Des Moines, Ia., has offered a prize to be given to the person selling the largest number of tickets for the grand charity concert. The winner will have a choice of a fine silver watch, a silver water pitcher or a clock.

The best Trade use the **ROY** Watch Case Co. Cases.



**Progress in the Formulation of a Half Rate Membership for the League.**

In accordance with a motion adopted at the last annual meeting of the Jewelers' League of the City of New York, President Hayes called a meeting of the committee on half rate membership Thursday afternoon. The committee consisted of the executive committee of the League, and the following nine members appointed by the president: J. W. Beacham, S. Bass, C. C. Champenois, Gilbert T. Woglom, W. C. Kimball, M. D. Rothschild, Henry Abbott, A. N. Webster and David S. Smith.

The committee met at the office of the League, 170 Broadway, New York, and elected Mr. Abbott chairman, and Levi Stevens, Jr., secretary. A motion was made and carried that President Hayes appoint a sub-committee of five to consist of three members from the committee-at-large and two from the executive committee to formulate a plan for half rate membership based on the plan taken from the table at the last annual meeting with such amendments as may seem proper.

The sub-committee appointed are: Mr. Beacham, chairman; and Messrs. Bass, Champenois, Jeannot and Van Deventer. The sub-committee have called a meeting for Wednesday afternoon at 3 o'clock.

**A Case of Much Interest to All Opticians.**

An interesting suit occupied the greater part of the past week in Part I. of the Court of Common Pleas, New York, before Chief Judge Sedgwick. The action was brought by Miss Clara Price, a school teacher, against Ga Nun & Parsons, opticians, 5 W. 42d St., to recover \$5,000 damages for injuries resulting from a mistake on the part of the defendants in not delivering certain glasses according to prescription.

Miss Price claimed that, in 1891, she took a prescription to Ga Nun & Parsons and had glasses made by them. After wearing these a short time she was frequently seized with attacks of vertigo, which finally forced her to give up her position as teacher as well as all other work. She had her eyes again examined by an oculist and obtained another prescription, which she also took to Ga Nun & Parsons to be filled. Then, she claimed, she was surprised to find that the prescription was the same as the former one, and discovered that a mistake had been made in the glasses she wore. She learned later that through this mistake she suffered from vertigo and so brought suit for damages.

The defendants claimed that the case alleged merely a breach of an implied warranty, for which damages could not be claimed. A motion to dismiss the complaint on this ground was denied by Judge Sedgwick. The defendants deny that any damage was done by their error and allege that the plaintiff's attacks were the result of her ill-health and not of the glasses, and that the difference in the glasses could not have had such a serious effect.

Judge Sedgwick Monday ordered a sealed verdict.

The jury rendered their verdict yesterday morning in favor of the plaintiff, giving her \$750.

**Death of Charles Kuhn, Senior.**

A figure which some years ago was prominent in the New York jewelry trade, passed away, in the death of Chas. Kuhn, senior, a former partner in the firm of Kuhn, Doerflinger & Co., 18 John St., which occurred in San Diego, California, March 11th. Mr. Kuhn's death was caused by a stroke of paralysis, the third from which he suffered during the past year.

The deceased was born 72 years ago in the Duchy of Baden, and from boyhood was connected with the jewelry trade. When 43 years old he came to this country and obtained employment with some of the leading manufacturing jewelers of this city; among whom were Geo. R. Downing & Co., Peckham, Dennis & Co., and Saffen & Styles. Among his fellow employes with the last named firm was George Doerflinger, who afterward became his partner. In 1862 he left Saffen & Styles to start in business for himself as a manufacturing jeweler and the next year he was joined by Mr. Doerflinger, the firm becoming Kuhn & Doerflinger.

Kuhn & Doerflinger were the predecessors of Kuhn, Doerflinger & Co., the firm name being changed some years ago when Mr. Kuhn's sons were admitted into the firm. In 1884 Mr. Kuhn retired, the firm continuing as of old. Two years after his retirement he went to California where he remained until his death.

**Boom for Julius A. Lebkuecher for Mayor of Newark.**

NEWARK, N. J., March 27.—More enthusiasm was displayed at the Republican primaries last night than there has been in years, owing to the fact that there were many candidates in the field, and a general impression seemed to prevail that a nomination was equivalent to an election. In the race for Mayor, Julius A. Lebkuecher, of Krentz & Co., holds a good place, one of his opponents being Assemblyman Woolsey, of Glorieux & Woolsey.

Mr. Lebkuecher, in a letter to Alderman Stainsby, yesterday denied the assertion

made by Mr. Roche, one of Assemblyman Woolsey's supporters, that he (Mr. Lebkuecher) was an atheist and an infidel. Mr. Roche has made the assertion in the presence of others. It now appears that Mr. Lebkuecher is a member of Oriental Lodge, F. and A. M., and a member of St. Luke's M. E. Church.

The following has been extensively circulated in the southern part of the city:

The people demand that the next mayor of the city of Newark shall be a man of recognized business ability, integrity, industry and energy. He must be a progressive, broad-minded man, able successfully to manage affairs of magnitude. He must represent the best intellectual and industrial progress of the city. He must be unconnected with corporations asking for franchises or municipal contracts. He must have both backbone and honesty, and when elected mayor he must himself fill the office.

Our neighbor, Julius A. Lebkuecher, has been a citizen of the city of Newark for forty years; he was educated at the public schools, and has spent his life in active business here.

He is, in our judgment, the man for the position. If elected mayor, he will fill the office with credit and honor to the city. If nominated, his election is assured.

We ask that delegates be elected in his behalf, and that every Republican of the ward attend the primaries to be held on Monday night.

The call was signed by many prominent citizens of Newark.

**SEEING**



is believing, and to see the product of our Optical prescription department, will lead you to believe that your popularity as an Optician will increase if we fill your orders.

**QUEEN & CO.,**

MANUFACTURING OPTICIANS,

1010 Chestnut Street, Philadelphia.

**IF YOU WANT A POSITION  
IF YOU NEED A SALESMAN  
IF YOU NEED A WORKMAN  
IF YOU DESIRE TO EXCHANGE  
IF YOU WANT A PARTNER  
IF YOU WISH TO SELL OUT  
IF YOU HAVE TOOLS TO SELL  
IF YOU HAVE A PLACE TO LET  
IF YOU WANT ANYTHING**

USE THE

**SPECIAL NOTICE PAGE**

OF THE

**JEWELERS' CIRCULAR,**

Published Every Wednesday.

**McINTIRE, ULMER & CO.,**  
**Manufacturing Opticians,**  
FRAMES, LENSES,  
**PRESCRIPTION WORK,**  
Expert Work at **LOWEST PRICES.**  
**WHOLESALE ONLY.**

S. E. Cor. 8th & Sanson Sts., PHILADELPHIA, PA.

Special drive in Eye Glass Hooks, \$3.25 per gross in lots not less than one-half gross. Single doz. 35 cts.



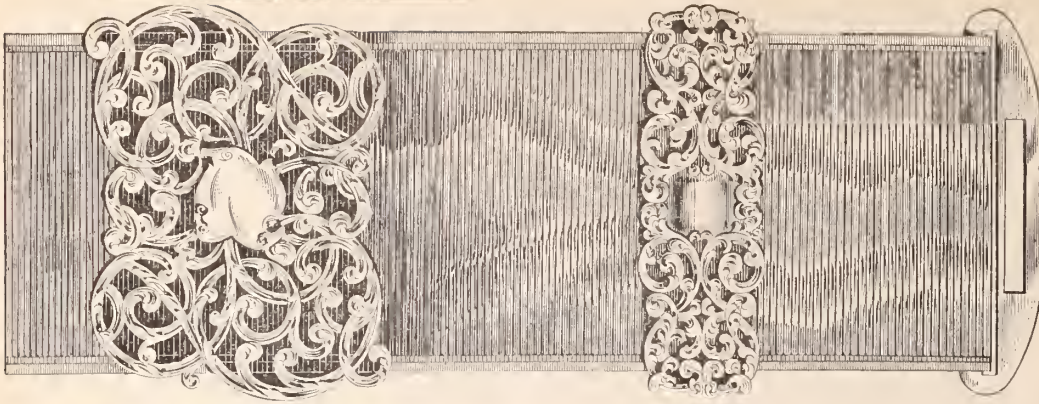

## Sterling Silver Belts

We are the originators of this style of belt and we propose to hold the trade on them.

Price \$1.25 complete,  
Moire Antique or plain ribbon.

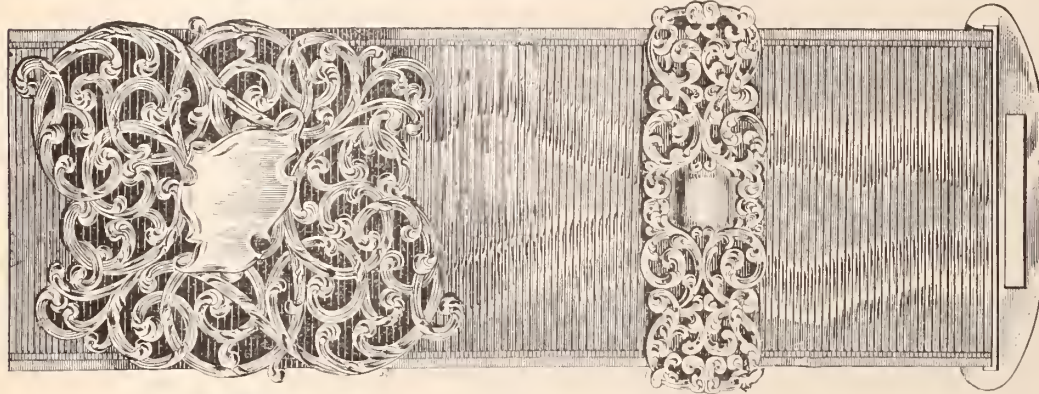

Price \$1.35 complete,  
Moire Antique or plain ribbon.

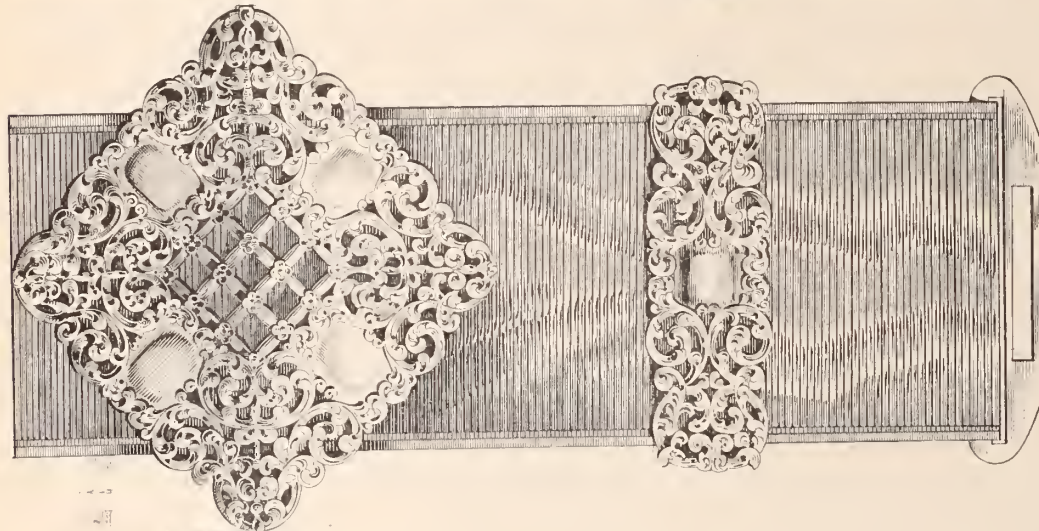

WE ARE PLEASED TO ANNOUNCE THAT NOTWITHSTANDING THE ENORMOUS DEMAND FOR THE MOIRE ANTIQUE BELTING, WE ARE IN A POSITION TO GUARANTEE SHIPMENT OF ALL ORDERS THE DAY FOLLOWING THEIR RECEIPT.

Price \$1.75 complete,  
Moire Antique or plain ribbon.

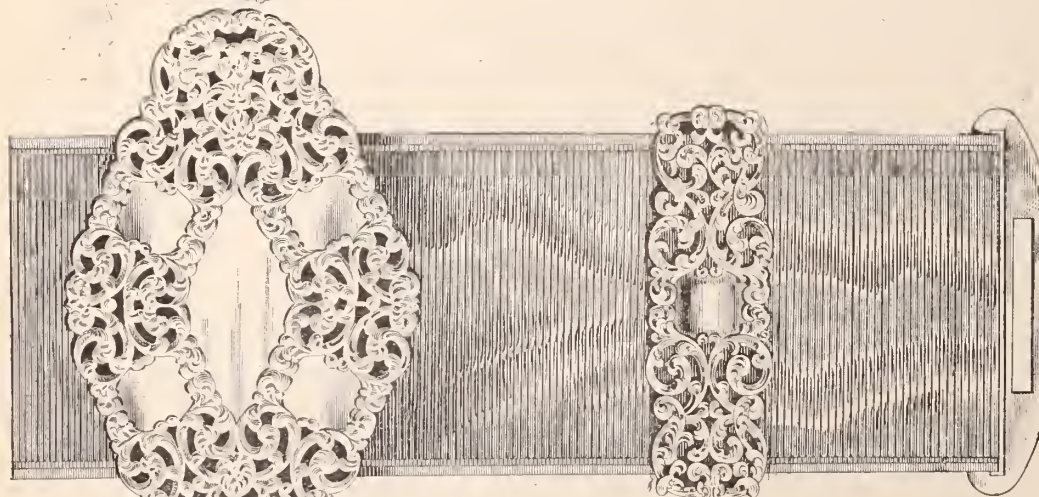

Price \$1.75 complete,  
Moire Antique or plain ribbon.

We beg to acknowledge the request of our customers asking us to discontinue quoting prices on goods advertised in the Trade Journals. After this issue we will only quote prices when we deem it necessary to protect a pattern.

**Unger Bros., 192 Broadway, N. Y.**



# The Jewelers' Circular

AND  
HOROLOGICAL REVIEW.

PUBLISHED EVERY WEDNESDAY BY

THE JEWELERS' CIRCULAR PUB'G CO.,  
189 BROADWAY, NEW YORK CITY.

A JOURNAL DEVOTED TO THE INTERESTS OF JEWELERS, WATCHMAKERS, SILVERSMITHS, ELECTRO-PLATE MANUFACTURERS, AND ALL ENGAGED IN KINDRED BRANCHES OF INDUSTRY.

Our Editorial columns will contain our own opinions only, and we shall present in other columns only what we consider of interest or value to our readers. Advertising matter will not be printed as news.

Advertising rates in THE CIRCULAR are lower, considering the number of tradesmen reached by its large circulation, than in any other jewelry journal.

Notices of changes in standing advertisements must be received one week in advance; new matter can be received up to Monday.

## INFORMATION FOR SUBSCRIBERS.

### Terms of Subscription, Postage Prepaid.

	PER ANNUM
United States and Canada, . . . .	\$2.00
Foreign Countries in Postal Union, . . . .	4.00
Single Copies, . . . . .	.10

New subscribers can commence at any time.

Payments for THE CIRCULAR, when sent by mail, should be made in a Post-Office Money Order, Bank Check or Draft, or an Express Money Order or Registered Letter. All postmasters are required to register letters whenever requested to do so.

Pay money only to authorized collectors having proper credentials.

Returning your paper will not enable us to discontinue it, as we cannot find your name on our books unless your address is given.

In changing address always give the old as well as new one. Your name cannot be found on our books unless this is done.

We will continue to send papers until there is a specific order to stop, in connection with which all arrearages must be paid; but such an order can be given at any time, to take effect at the expiration of the subscription. All such orders will be promptly acknowledged by mail.

The Courts have decided that all subscribers to journals are responsible until arrearages are paid in full and an order to discontinue has been received by the publisher.

Member of the American Trade Press Association.

Vol. XXVIII. March 28, 1894. No. 3.

Uncut diamonds are to come in free of duty, and the toilers of the land will not have to pay "robber barons" duties on their diamonds in the rough. The duties on other precious stones, cut but not set, are also put down, presumably in the interest of the working men.—*Mail and Express.*

OUR esteemed contemporary is not right in its conclusions. The reductions made by the Democratic members of the Senate Finance Committee in respect to precious stones are in the interests of legitimate commerce and of Government revenue. Free of duty for rough and 10 per cent. duty for cut and uncut, as now exist, are the proper tariff schedule for precious stones.

**The Problem of Diamond Making.** AS reported from Paris in a recent number of THE CIRCULAR, Henri Moissan has made a report to the Academy of Sciences, on his artificial production of diamond. We have before had occasion to refer to this gentleman's very interesting experiments in the use of very high tem-

# Spanish-American Edition of The Jewelers' Circular.

The forms of the Spanish-American edition, to be circulated in South America (east and west coasts), Cuba, Mexico and Central America, are now being prepared and advertisers are earnestly requested to forward copy for their announcements at once. The edition will be issued **Next Week**. Copy for advertisements is to be sent to us in English, which we will properly translate into Spanish. If you desire space in this number please communicate with us AT ONCE as only a limited amount is now open; rates will be made known upon application.

Yours truly,

The Jewelers' Circular Publishing Co.

peratures and the preparation of carbon under pressure. Last year M. Moissan succeeded in obtaining black crystals of carbon, approaching the diamond in several respects. He has since continued his experiments, and has, by placing his carbon prepared under high pressure in a bath of melted lead and allowing it to cool, obtained crystals of a variety of carbon, some of which are black and others transparent. These crystals have a density of from 3.0 to 3.5, will mark ruby, are not acted on by a mixture of chlorate of potassium and nitric acid and finally will burn in oxygen at a temperature of 900° C., giving about four times their weight in carbonic acid. In other words, they have all the properties of the natural diamond. It would seem from this that M. Moissan has solved the problem of making diamonds, but his success is purely experimental, and it is not at all likely that the production of this precious stone will be done on a commercial scale. No slump in the market prices of diamonds may be expected through M. Moissan's competition, and the DeBeers Consolidated Mines Co. and the importers of gems may rest easy.

## To Seek Foreign Markets.

THE Antwerp Exhibition promises to offer fine chances to American manufacturers for the display of their wares and fabrics. Already many American productions are well and favorably known in Belgium, but we are still far behind our possibilities in foreign markets, our low-priced watches and clocks, among other native productions, not commanding the trade that is rightfully theirs by reason of their acknowledged worth. One reason for this failure is the higher cost of the American article compared with its foreign competitor. It has also been an unfortunate characteristic in American attempts to gain a foreign market that we have not first learned the fashions or the tastes of that market. The independence of the American citizen has in this particular operated to his disadvantage. The American exhibits at the Antwerp exposition will be shown under the direction of the American Propaganda in a special building—the only foreign building on the

ground used for exhibition purposes—and thus exhibitors and possible buyers can be brought into close companionship.

## The Week in Brief.

JOHN B. YATES, New York, made an assignment—M. L. Read & Co., Providence, R. I., assigned—Benj. S. Wise & Co., New York, gave bills of sale—Geo. W. Luce, Columbus, O., charged with being a fence, was adjudged insane—The Greene & Knox Mfg. Co., Providence, R. I., was organized to succeed Wm. C. Greene & Co. and Holden & Knox—Bids for furnishing the Government with anemometer registers were opened—The California Clock Advertising Co., of San Francisco, incorporated—Argument on the appeal of the Keystone Watch Case Co. in the action of the Pairpoint Mfg. Co. and others against the Philadelphia Optical & Watch Co. was heard—James G. Thompson & Sons, Sioux City, Ia., were succeeded by a corporation—F. Backstein, San Francisco, Cal., was attached—A much wanted thief was captured in Los Angeles, Cal.—Bids for furnishing a town clock for the Post Office in Lowell, Mass., were opened—Herbert R. Phillips, Chicago, Ill., died—Several judgments were granted against Adolph Shakman, Chicago—F. G. Smith, Sons & Co., Detroit, Mich., made an assignment—L. L. Norton, Indianapolis, Ind., filed chattel mortgages—The death occurred of Thomas Windle, Providence, R. I.—Van Houten Bros., Newark, N. J., gave a chattel mortgage—The death occurred of Charles Kuhn, Sr., founder of Kuhn, Doerflinger & Co., New York—A suit interesting to all opticians was tried in New York, Ga Nun & Parsons being the defendants—A meeting of the half rate membership committee of the Jewelers' League was called by the president—J. Albert Koons, Philadelphia, Pa., assigned—Fritz Dhein was sentenced for robbing a salesman of the Herman Keck Mfg. Co., Cincinnati, O.—Henry Silverthorn, Lynchburg, Va., assigned—Another attempt was made to rob Wm. B. Morse, Boston, Mass.—The deaths occurred of John M. Hofart, Lancaster, Pa., and Edward M. Marshall, Natick, Mass.



**New York Notes.**

Max Frennd & Co. have entered a judgment for \$140.83 against Frederick Frey.

Geo. M. Neff, dealer in diamonds and watches, has opened an office at 113 Broadway.

J. H. French is conducting an auction sale of the stock of E. A. Thrall, 176 Broadway.

A judgment for \$199.12 has been entered against Moses J. Lichtenberg by Wm. C. Hutchins.

Elmer E. and Chas. F. Wood of Chas. F. Wood & Co., returned from Europe Sunday on the *New York*.

Martin Metzgar, formerly of 5 and 7 Maiden Lane, is now instaled in new quarters at 206 Broadway.

A handsome silver prize cup for the Biscayne Bay Yacht Club has been furnished by H. N. Squire's Son, 14 John St.

M. Hirsch, Chicago, sailed last week for Europe on the *Aller*; R. Horstmann, Berlin, Germany, left on the *Campania*.

Albert Schmidt will give up his store at 1007 Broadway, Brooklyn, May 1st, and remove his stock to his other store, at 136 Throop Ave.

R., L. & M. Friedlander, jobbers in watches, jewelry, optical goods and materials at 65 Nassau St., will remove May 1st to the store on the ground floor of 38 Maiden Lane.

The liquidation sale of the stock of the Jas. H. Hart corporation, 541 Fulton St., Brooklyn, still continues. A. J. Comrie, the auctioneer, commenced the special catalogue sale Monday.

August Delin, said to be a jeweler of Parkville, Flatbush, was taken into custody last week and sent to the Kings County Hospital. Delin has been acting queerly of late and his family asked that he be examined as to his sanity.

The A. C. Smith Watch Co. have been incorporated under the laws of New Jersey for the purpose of manufacturing and selling Paillard non-magnetic and other special watches. They have opened an office at 177 Broadway, and will continue the business of the Non-Magnetic Watch Co.

Abram Roseman, of Roseman & Levy, 41 Maiden Lane, was the victim of either sneak thieves or burglars last week. During the absence of the family on Tuesday evening, March 20th, Mr. Roseman's residence, 145 W. 125th St., was broken into, and diamonds worth \$600 together with silverware was stolen. The thief or thieves have not yet been discovered.

Hagan, White & Co. will move into their handsomely furnished new offices at 248 W. 23d St., about April 1st. They have been fortunate in securing the services of A. B. Spear, who is known as one of the oldest and most efficient salesmen in the trade. Mr. Spear has left for the south with a large line of silver goods. Two other travelers for Hagan,

White & Co. are looking after the firm's interests in the east and west.

J. S. Birch & Co., 70-80 Washington St., Brooklyn, have sold the patents, machinery and tools for the manufacture of the well-known Birch key to Kendrick & Davis, manufacturers of watch keys, Lebanon, N. H., who will continue their manufacture. The machinery is now being removed to Lebanon. Kendrick & Davis, the purchasers of the plant, have manufactured a dust proof watch key for the past 15 years.

Chas. H. Homans, who, as told in THE CIRCULAR last week, attempted to pass a stolen check for \$1,250 upon Hayden W. Wheeler & Co., 2 Maiden Lane, was held in the Tombs Police Court Wednesday in \$5,000 bail for trial. The previous day Post Office Inspector Seymour, of Philadelphia, appeared before Commissioner Shields and swore out a warrant for the arrest of Homans, charging him with the theft of several mail pouches, which were stolen while in transit from this city by the Pennsylvania Railway a short time ago.

Upon complaint of the United States Customs' Inspectors, Weill de Bonilla, a guest at the Hotel Martin, was arrested last week on the charge of smuggling. Bonilla and his wife arrived on the 19th on *La Bretagne*. Their baggage was passed aboard the steamer, but upon a message from Paris it was searched at the hotel, and a lot of silverware and jewelry discovered. M. de Bonilla was held in \$3,000 bail for examination by Commissioner Shields. The accused said he had no intention of violating the law, and had intended to take the jewelry to Buenos Ayres.

The Grand Jury last week dismissed the complaint against Chas. A. Jacques, the former president of the Chas. Jacques Clock Co., who was charged with fraudulently issuing notes of debt of a corporation. The complainant, Montague F. Harris, one of the directors of the company, charged the president with issuing false chattel mortgages without the consent, and against the wishes of the directors of the company, for the purpose of covering promissory notes issued to the Chatham National Bank. The bill was dismissed without the customary explanation of the grand jury attached to it.

The tearing down of the buildings at 69 Nassau St. and 28 John St., which will commence May 1st, will cause the following removals: M. Weiner, manufacturing jeweler, Shiman Bros., makers of mountings, and B. Friedman, to 39 Maiden Lane; P. J. Richrath, chronometer and watchmaker, and B. Veit, dealer in watches and jewelry, remove to the Sheldon Building, John and Nassau Sts., May 1st; Robert Shaefer, manufacturing jeweler, A. Van Benschoten, dealer in jewelry, and Freeman Bros., to 9 Maiden Lane; Troeher Bros., manufacturers of cases, have not yet decided on their new location.

The E. Howard Watch & Clock Co. have made an enormous clock for the tower of

Smith, Gray & Co.'s new building, at Fulton St., and Flatbush Ave., Brooklyn. The dials of the clock are five in number. They are of a skeleton iron framework, with heavy plate glass. Each clock face is 15 feet in diameter. The wheels of the clock are of hand-hammered brass, and the teeth are accurately cut. As is usually the case with the large timepieces manufactured by the E. Howard Company, the clock works by force of gravity. One of the dials which was on view at the foot of the tower last week attracted a great deal of attention from the crowds on Fulton St.

The games rolled by the Jewelers' Individual Bowling Club Monday night resulted in the following scores:

Mangold.....	156	Woodland.....	155
".....	124	".....	195
Roll.....	152	Ruefer.....	157
".....	143	".....	148
Shiman.....	185	Townley.....	181
".....	171	".....	161
Woodland.....	150	Hovet.....	147
".....	158	".....	162
Townley.....	171	Thornbury.....	112
".....	128	".....	169
Roll.....	188	Hovet.....	123
".....	186	".....	158
Shiman.....	195	Mangold.....	114
".....	143	".....	139
Ruefer.....	138	Townley.....	148
".....	172	".....	179
Thornbury.....	120	Hovet.....	180
".....	117	".....	195
Roll.....	146	Woodland.....	140
".....	151	".....	152

**The Jewelers' Relief Association Assist Many People.**

The general committee of the Jewelers' Relief Association met at the headquarters of the organization, 11 Maiden Lane, New York, Wednesday afternoon. In the report read by president Max J. Lissauer, he stated that relief had been given to 310 of the cases investigated. Each case averaged a family of four persons, making the total number of people assisted over 1200. The society in its work has spent about \$4,000. Work has been furnished for 25 applicants. No decrease is yet noticeable in the number of applicants for assistance.

Among the latest subscribers to the fund which now amounts to over \$7,173, were employes of the following firms, who contributed the amounts below mentioned: Employes of Vve. L. B. Citroen & Co., \$11; Howard & Cockshaw, \$5.75; Jules Racine & Co., \$6; Max Freund & Co., \$7; E. P. Reichhelm & Co., \$10; W. S. Hick's Sons, \$10; A. Straus, \$5; Carter, Sloan & Co., \$26; J. T. Scott & Co., \$5; Jewelers' Circular Publishing Co., \$3; Oppenheimer Bros. & Veith, \$30; Leonhardt & Curran Manufacturing Co. \$10; A. Frankfield & Co., \$6.25; and F. W. Gesswein, \$15.

T. Tickers' store, Parkville, Ont., was burned out last week.

Charles Vanderliss and Wm. Charles who broke into Dan Beatty's jewelry store, Montreal, a few days ago, were sent to the penitentiary for five years each.



**L. TANNENBAUM & CO.,**  
**Importers and Cutters of DIAMONDS AND PRECIOUS STONES,**  
**COR. MAIDEN LANE & NASSAU ST., NEW YORK.**

Telephone, Long Distance, 1959 Cortlandt.

25 HATTON GARDEN, LONDON.

IN ORDER TO REDUCE OUR ENORMOUS STOCK WE OFFER THIS WEEK AT SPECIAL PRICES, THE FOLLOWING GOODS:

Rough Siam Rubies for cutting purposes, at 50c. per karat.  
 Rough Fancy Sapphires for cutting, at 25c. per karat.  
 Rough Sapphires for mechanical use, and precious stones for collections.

**OPALS.**

16,462	101 Fine Opals, 45 28-64 kt., a great bargain,	\$10.00	per kt.
12,460	62 " " 35 36-64 kt.,	9.00	"
2,412	Very Fine Round Opals, 14 49-64 kt.,	12.00	"
B-328	Small Round Opals, 22 less 4-64 kt.,	7.00	"
4,471	Opals, 65 1/4 kt.,	9.00	"
8,471	Opals, 57 7/8 1-64 kt.,	10.00	"
329	Opals, 80 38-64 kt.,	9.00	"
5,471	Opals, 66 53-64 kt.,	10.00	"

**BRILLIANTS.**

110	18 Brilliants, 21 3/4 kt., white and perfect,	\$60.00	per kt.
110	26 " 35 7/8 1-64 kt., " "	65.00	"
110	25 " 23 7-64 kt., " "	58.00	"
110	146 " 159 1-16 kt., well made by waters,	42.00	"
132	Fine Small Melee, 25 1/2 kt., 1,150 stones,	45.00	"
126	Fine Blue White Melee, 28 kt.,	52.00	"
125	Fine White Melee, 64 kt.,	37.00	"
107	78 Brilliants, 111 kt., fine cape white,	48.00	"

**SAPPHIRES.**

4 489	7 Fine Sapphires, 9 1/4 1-32 kt.,	\$25.00	per kt.
A-8,658	12 Fine Sapphires, 16 7-64 kt.,	25.00	"
8,488	26 Very Fine Sapphires, 12 1/4 1-64 kt.,	18.00	"
23,348	11 " 15 18-64 kt.,	14.00	"
2,967	Fine Small Sapphires, 67 less 1-32 kt.,	6.00	"
7,212	" " 45 3/4 1-64 kt.,	8.00	"
19,486	25 Sapphires, 12 7/8 kt.,	12.00	"
1,193	50 " 28 less 1-32 kt.,	4.00	"
2,217	33 " 15 2-64 kt.,	6.00	"
5,311	41 " 35 3/8 kt.,	3.00	"

**EMERALDS.**

2,375	20 Emeralds, 23 less 2-64 kt., a bargain,	\$40.00	per kt.
9,377	35 " 20 7/8 less 1-32 kt.,	20.00	"
1,375	280 " 71 1/2 kt.,	40.00	"
1,389	71 " 55 3/4 kt.,	60.00	"
A-12,366	284 Emeralds, 62 1/4 1-16, kt.,	50.00	"
7,377	10 Emeralds, 16 7/8 kt.,	22.00	"
25,377	47 " 21 1/2 kt.,	60.00	"

**RUBIES.**

14,335	12 Rubies, 6 1-16 kt.,	12.00	per kt.
5,149	65 " 38 7/8 kt.,	18.00	"
5,169	" 62 3/4 1-16 kt.,	10.00	"
A-2,186	50 " 16 52-64 kt.,	8.00	"
12,337	14 " 8 8-64 kt.,	15.00	"
8,184	36 " 20 less 1-64 kt.,	12.00	"
5,342	Small Fine Rubies, 39 7/8 1-32 kt.,	8.00	"
3,184	" " 34 7/8 1-32 kt.,	7.00	"
3,167	" " 20 3/8 1-16 kt.,	2.00	"
1,148	" " 88 1/4 kt.,	4.00	"
7,148	" " 91 3/4 kt.,	5.00	"

**CATSEYES.**

18,244	21 Fine Catseyes, 18 3/8 kt.,	\$12.00	per kt.
28,222	11 " 10 61-64 kt.,	15.00	"
27,419	1 " 5 28-64 kt.,	25.00	"
34,221	1 " 13 less 4-64,	30.00	"
15,221	1 " 21 12-64 kt.,	20.00	"
14,222	1 " 13 3/4 kt.,	25.00	"
10,221	Fine Catseye, 11 1-16 kt.,	20.00	"
33,222	18 Fine Catseyes, 37 3-64 kt.,	8.00	"

**FANCY SAPPHIRES.**

25,123	30 Fancy Sapphires, 18 1/2 kt.,	\$5.00	per kt.
36,124	25 " 20 less 4-64 kt.,	6.00	"
36,317	22 " 22 6-64 kt.,	6.00	"

**Battin & Company,**

MAKERS OF

Gold • and • Silver • Novelties,

Third Ave. & Ogden St.,

Newark, N. J.

STERLING SILVER SILK WINDERS.

EXACT SIZES.

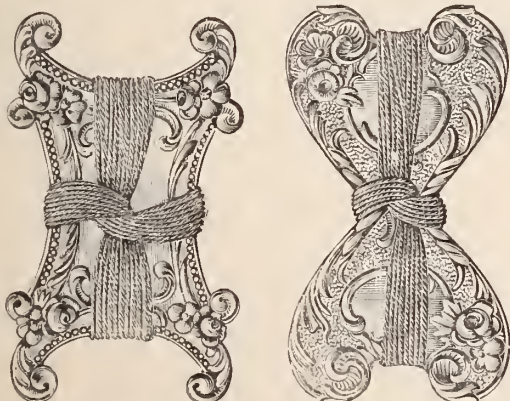

\$9.00 PER DOZ.

\$9.00 PER DOZ.



STERLING SILVER TOP, RED SILK EMERY BAGS.

EXACT SIZES.



\$9.00 PER DOZ.

\$6.00 PER DOZ.

ORIGINAL DESIGNS.

BEST FINISH.

POPULAR PRICES.



The Bureau of American Republics.

THE CIRCULAR having received inquiries for the publications of the Bureau of American Republics, as a result of the editorial, Export Trade to the Southern Nations, in this journal of March 21st, it is in place to reprint a letter from the Bureau, received by THE CIRCULAR last week, apropos to the supplying of copies of these publications. The letter is as follows:

DEPARTMENT OF STATE, WASHINGTON, U. S. A., —, 1893.

DEAR SIR:—Requests for copies of the publications of this bureau are received in numbers exceeding the possible supply. The annual appropriation for printing these documents is only sufficient to furnish copies for the libraries of educational and commercial institutions, for the domestic and foreign newspaper press, for United States diplomatic and consular agents, and representatives of foreign governments related to the bureau. Yet it is well understood that many requests are received from persons having good reasons for desiring the information asked for, and both willing and able to pay the slight cost of these documents.

Under these circumstances, it has been deemed desirable to extend the usefulness of the bureau by making arrangements for the sale of its publications to those applying. I therefore take pleasure in enclosing a catalogue of the bulletins published since the organization of the bureau, of which copies may be secured in limited quantities by application to the Public Printer, Washington, D. C., who will forward them on receipt of the price named in the list.

It is believed that this course will result in a more general circulation of the information secured and published by the bureau, and in saving the unnecessary labor of replying to requests from persons who, apparently, have no special interest in the publications applied for, and no definite object to be subserved. All who have a well-grounded intention of embarking in business in foreign countries will presumably be able to afford the slight expense involved in the payment of the cost price of the bureau documents.

Many of the earlier bulletins have been included in more recent publications. This applies especially to the tariffs, commercial directories and newspaper directories of the different republics.

The bureau has in course of preparation brief state-

ments of the development of different industries in the United States, Central and South America, which will be issued monthly in accordance with the recommendations of the International American Conference.

All orders for the publications of this bureau must be addressed to "The Public Printer, Washington, D. C.," and must be accompanied with the money for same. No money will be received by this bureau.

Suggestions from manufacturers and dealers as to their special needs of information will be thankfully received by the bureau.

CLINTON FURBISH, Director.

PRICE LIST OF PUBLICATIONS OF THE BUREAU OF AMERICAN REPUBLICS.

Table listing publications and prices: 3. Patent and Trade-mark Laws of America \$0.05, 4. Money, Weights and Measures of the American Republics .05, 6. Foreign Commerce of the American Republics .20, 8. Import Duties of Brazil .10, 10. Import Duties of Cuba and Puerto Rico .15, 11. Import Duties of Costa Rica .10, 13. Commercial Directory of Brazil .05, 14. Commercial Directory of Venezuela .05, 15. Commercial Directory of Colombia .05, 16. Commercial Directory of Peru .05, 17. Commercial Directory of Chile .05, 18. Commercial Directory of Mexico .15, 19. Commercial Directory of Bolivia, Ecuador, Paraguay and Uruguay .05, 20. Import Duties of Nicaragua .10, 21. Import Duties of Mexico (revised) .15, 22. Import Duties of Bolivia .20, 23. Import Duties of Salvador .05, 24. Import Duties of Honduras .10, 25. Import Duties of Ecuador .05, 26. Commercial Directory of the Argentine Republic .05, 27. Import Duties of Colombia .05, 29. Commercial Directory of Haiti and Santo Domingo .05

Table listing publications and prices: 30. First Annual Report of the Bureau, 1891 .10, 32. Handbook of Guatemala .35, 33. Handbook of Colombia .30, 34. Handbook of Venezuela .35, 36. Import Duties of Venezuela .05, 42. Newspaper Directory of Latin America .05, 43. Import Duties of Guatemala .25, 44. Import Duties of the United States .05, 45. Import Duties of Peru .25, 46. Import Duties of Chile .25, 47. Import Duties of Uruguay .25, 48. Import Duties of the Argentine Republic .25, 49. Import Duties of Haiti .10, 50. Handbook of the American Republics, No. 3 .50, 53. Immigration and Land Laws of Latin America .40, 55. Handbook of Bolivia .40, 63. How the Markets of Latin America may be Reached .40, Publications not numbered— Commercial Directory of Latin America .40, Second Annual Report of the Bureau, 1892 .05, Manual de las Republicas Americanas, 1891 .50, The supply of publications not mentioned in the foregoing list has been exhausted, but new editions will probably be issued, in which event the missing numbers, with price of each, will be given in an amended list. 28. Commercial Directory of Central America .10, 38. Commercial Directory of Cuba and Puerto Rico .10, 39. Commercial Directory of European Colonies .10, 51. Handbook of Nicaragua .50, 61. Handbook of Uruguay .50, 62. Handbook of Haiti .50

WE manufacture Souvenir and Advertising Spoons in Sterling,

Aluminum and

Electro-Plate.



Also

Electro-Plated Spoons, Forks, Knives, Etc.

NIAGARA SILVER CO.,

454 Main Street,

NIAGARA FALLS, N. Y.



**Providence.**

E. Wertheimer, New York, was in town last week.

Brown & Sharpe Mfg. Co. are now starting up on ten hours a day.

Julian Rathbone was married last week to Miss Esther C. Williams.

John Allen, of Allen & Jonassohn, is the happy father of a baby boy.

E. H. Saxton, of Boston, was in town Friday calling upon members of the trade.

Tilden-Thurber Co. have had their charter amended to allow of the issuing of preferred stock.

Martin L. Read has been confined to his house, at Riverside, the past week by ill health.

Frank Chase, manager of J. A. Foster & Co.'s Fall River, Mass., store was in town last Tuesday.

S. W. Bassett & Co. will be represented in Philadelphia by Chas. Y. A. Thompson, 722 Chestnut St.

Bernard Crossin is making an extended trip through the west in the interests of Crossin & Tucker.

Charles F. Irons, of Irons & Russell, started last week for a month's trip on business and pleasure to Cuba.

Geo. L. Vose, assignee for Jas. R. Feeley & Co., has not as yet concluded his inventory of the stock and accounts.

The Legislature has passed an act to increase the capital stock of the Gorham Mfg. Co., not to exceed \$5,000,000.

H. J. Covelle, formerly with the Tilden-Thurber Co., has started in business for himself at 75 Westminster St., in the office with A. W. Sawyer.

George W. Milkman, who carried a side line of jewelry, made an assignment last week to Robert Thompson. His jewelry liabilities will not exceed \$500.

William H. Manchester & Co. have removed from 12 Conduit St. to 66 Stewart St., where they will occupy the former shop of Holden & Knox.

The affairs of the Seery Mfg. Co. appear to be in a fair way of speedy settlement, as many of the creditors are favorable to the offer of 25 cents on the dollar.

It is understood that the offer made by Assignee Rathburn, of Harrington & White, amounting to 15 per cent., is not acceptable to a majority of their creditors.

J. B. Libeller, who recently started in the jobbing business on Broadway, New York, has been in town the past week making the acquaintance of local manufacturers.

John J. Fry has placed a keeper in charge of the factory of Smith & Greene, manufacturers of chains and charms, 185 Eddy St. The Excelsior Chain Co. are also temporarily suspended.

Intelligence was received in this city Friday morning of the assignment of John B. Yates, of 23 Maiden Lane, New York, with

assets at \$25,000 and liabilities of \$40,000. Local manufacturers are interested for about \$4,000 or \$5,000.

Lothrop & Livesey succeed Joshua Lothrop & Co., 61 Peck St., the firm consisting of Joshua Lothrop and Joseph A. Livesey. All the claims against the old firm of J. Lothrop & Co. have been satisfactorily settled.

S. J. Weeden & Co., 31 Clifford St., have been succeeded by Weeden & Barker. The new concern is composed of S. J. Weeden, formerly with A. S. Southwick & Co., and Edgar R. Barker, for several years with D. Wilcox & Co.

In the District Court last week the case of Smith & Greene against Frank J. Johnson was heard. This is a petition for preliminary injunction, which was heard and held for advisement as to the form of an order from the production of the books of the respondent.

The General Assembly has granted an amendment to the charter of the Burdon Seamless Filled Wire Co. increasing the capital stock to an amount not to exceed \$400,000. One of the reasons for this increase is explained by the fact that the corporation intend erecting a new building costing \$200,000.

James A. Goodwin, for several years traveling salesman for various local manufacturing jewelry firms, but lately advance agent for the Craigen-Paulding Dramatic Co., has been missing from Omaha, Neb., for the past ten days, having in his possession about \$700 of the company's money. It is thought that he has been foully dealt with.

Holden & Knox have removed from 66 Stewart St. to 98 Pine St., where the firm has been consolidated with Wm. C. Greene & Co. Mr. Greene was a special partner in Holden & Knox. The business of these concerns will be continued by the Greene & Knox Mfg. Co., organized under the corporation laws of Rhode Island. The president is William C. Greene, and John Knox, treasurer.

Never for a number of years has this city and State been so stirred up over politics as this Spring, and that the jewelers are by no means disinterested in the imbroglios the following will indicate: Delegates to City Convention from Ward 1, George H. Wood; from Ward 6, Frederick Reuckert and Hoffman S. Dorchester; from Ward 7, William N. Otis and Charles E. Hancock; from Ward 9, Silas H. Manchester, Francis P. Daughaday and John M. Buffinton. Delegates to the State Convention: Ward 6, Charles H. Sutch; Ward 8, George L. Vose. Members of City Committee: Ward 5, Fred H. Mason; Ward 6, Ernest Reuchart; Ward 8, Telesphore Stahl. These are all on the Republican ticket. Republican Supervisors appointed are: Ward 1, District 2, Pitts S. Bliven; Ward 4, District 1, Edward C. Haven and John C. Harrington; Ward 5, District 1, Louis Schmidt; Ward 8, District 2, Telesphore Stahl.

**SILVER**  
**Deposit Cologne.**

PURE SILVER <sup>1,000</sup>/<sub>1,000</sub> FINE.



**ALVIN MFG. CO.,**  
860 BROADWAY, NEW YORK.

**WM. SCHWARZWAELDER & CO.,**  
Fulton St., cor. Pearl, - NEW YORK

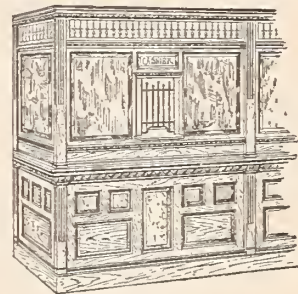

MANUFACTURERS OF  
**DESKS, CHAIRS, Etc.**

Jewelers' Cases and Counters. Office Partitions, Rails, Etc.

Special Designs, Plans, Prices, etc. upon application.

For **BADGES AND MEDALS,**  
Flag Pins, Class Pins, Class Rings  
and Special Work of all Descriptions.  
SEND TO **E. R. STOCKWELL, MANUF'R.**  
19 John Street, New York.



THE WESTERN TAKE ITS WAY

# WESTERN SUPPLEMENT of THE JEWELERS' CIRCULAR

**Chicago Office: Room 517, Inter-Ocean Building.**

VOL. XXVIII.

CHICAGO, WEDNESDAY, MARCH 28, 1894.

No. 8.

### Chicago Notes.

Kelley, Maus & Co. have sued Adolph Pentz for \$633.56.

O. W. Wallis and wife passed the week at Mount Clemens, Mich.

F. M. Sproehle and family returned Monday from their southern trip.

L. Newhouse, of Glickauf & Newhouse, is sending in good orders for tools and materials from the west.

C. D. Peacock, Jr., and Mrs. Peacock (née Lehmann), have returned from their bridal trip in the west.

A judgment on finding for \$944.74 was granted Alva Owen against John M. Bredt in the Circuit Court March 19th.

M. A. Mead left early last week for a visit to his family in their Denver home. Mrs. Mead will return to Chicago early in June.

Edwin A. Giles, receiver for Giles, Bro. & Co., has brought suit in the Circuit Court for \$1,000 against Knowlton L. Ames.

Lem. W. Flershem, of Lapp & Flershem, and Mr. Ellbogen, of Stein & Ellbogen, spent the past week recreating at West Baden Springs.

W. J. Ward has removed his watch club business from 71 Washington St. to suite 605-7 Columbus building. Factories starting up have improved business with those concerns.

A harp formed of gold watch cases with chains for strings, on a background of green silk formed the appropriate center piece in the window display of G. F. Gillman, on St. Patrick's day.

Julius Kahn, formerly of Milwaukee, and later of Iron Mountain, Mich., will open a store April 1, in Appleton, Wis., as A. J. Kahn. Mr. Kahn made good purchases the past week in this city.

H. W. Anderson has removed from 71st St. and Cottage Grove Ave. to 924 W. Madison St. Mr. Anderson is a son of Tom Anderson, the well-known traveler for M. A. Mead & Co., who recently died.

Max Meyer, the well-known jobber of Omaha, is a devotee of music, as was evidenced by his coming to Chicago to attend the grand opera season in this city. The party, numbering 60 persons, left for home Saturday.

The mother of R. L. Hogarth, cashier for the Geneva Optical Co., is very ill at her home in Geneva, N. Y., and recovery is doubtful. Mrs. Hogarth is the widow of the late Rev. Wm. H. Hogarth, an eminent divine in the Presbyterian Church.

In the Superior Court Frederick H. Larter *et al.*, have filed suit against Frank Reilly and Wm. G. Curtis for \$600. This is an aftermath of the Reilly & Curtis failure. Marshall Field & Co., in the same court want \$500 from E. Graham Rhoads.

Manager M. Loeb, of the Wadsworth Watch Case Co., received from Newport Tuesday last a handsome gold watch with monogram, M. L. finely engraved on plain ground—the gift of the firm. It is a fine timepiece inclosed in handsome case.

**INQUIRER:** "Optician" to whom you refer is well qualified both by mental endowment and long experience to establish an optical department in your store, and place it upon a paying basis. Not only this, but he had the foresight to see that the jeweler required just such help as he offers.

Otto Young, it is reported, has purchased the property 40x180 feet, north front, on Lake St., immediately east of the Tremont House, for \$115,000, the grantors being the McCord estate. The transaction includes a five-story building which is under lease for three years at \$8,000 a year.

"Trade is picking up," said M. A. Mead, in an interview. "Every day of this month exceeds the corresponding day of last month. April gives promise of being better than March, and we look for a gradual but steady improvement throughout the year. While the first six months will fall behind last year, the last six will undoubtedly be far ahead."

Judgments granted Tuesday last in the

Circuit Court against Adolph Shakman were as follows: Watson, Newell & Co., \$2,982.05; Hancock, Becker & Co., \$346; Wm. H. Smith, *et al.*, \$165.60; Wightman & Hough Co., \$590; Horton, Angell & Co., \$1,987.48; R. L. Griffith & Son, \$518.34. Shakman failed some time ago and the judgments were secured for use in case assets should be brought to light.

Hubert R. Phillips, whose wide business career was noted in *THE CIRCULAR* last week, died at his home on the West Side, Wednesday morning, at 10 o'clock. Mr. Phillips was confined to the house Aug. 17th last, with a cancerous growth in the stomach, and never afterward left the house. The funeral was held at the Centennial Baptist Church, Friday, the remains being interred at Rose Hill Cemetery.

Benj. Allen & Co. greet the trade with a new illustrated price list of watch materials, tools and jewelers' supplies for 1894-95, just issued. No pains or expense have been spared in their endeavor to present a book of unusual merit, fully illustrative of all goods in the above lines. Especial attention is directed to the many reductions in prices. The Waltham material alone requires 84 pp.; Elgin, 57, and other American and imported material 66 pp. Case material fills 10; jewelers' findings, 19; tools, 170; Grout's signs, illuminated in gold, 12; besides scores of pages of miscellaneous useful articles. The work is printed on fine paper and is well bound in durable cloth covers. Each one of the 464 pages of this latest of tool and material catalogues contains matter of interest to all progressive jewelers.

A marked improvement is noted in all the jobbing houses and a renewed activity unusual of late. An increased number of buyers and busy shipping rooms and counting rooms betoken a brightening in the western jewelry trade that is most encouraging. Silver has shared in the general revival to the extent that country orders are increasing. The absence of weddings and the consequent loss of trade in the way of presentation pieces is partly made up by



the increased sales of communion services. Watches, as elsewhere stated by Mr Mead, are now coming well to the front and watch case manufacturers report improved business. The following out-of-town merchants contributed to bringing about the improvement: G. F. Schmermund, Greenville, O.; Frank LeBron, Keokuk, Ia.; Mr. Pierik, Springfield, Ill.; Dave Drummond, La Crosse, Wis.; C. K. Hamilton, Emerson, Manitoba; Mrs. A. I. LeVeque, Iron Mountain, Mich.; Julius Kahn, Appleton, Wis.; A. C. Pino, Greene, Ia.; Smyth & Lawrence, Elgin, Ill.; W. P. Yeoman, Waukegan, Ill.; R. E. Winter, Fort Sheridan, Ill.; W. T. Beauchamp, Terre Haute, Ind.; J. R. Schneider, Evanston, Ill.; L. M. Bird, Aurora, Ill.; H. Thacker, Waukegan, Ill.; Fritz Hoefler, Aurora, Neb.; S. Hagadon, Selma, Ala.; O. S. Clayton & Son, Aurora, Ill.; Eggeman & Son, Aurora, Ill.; L. Luchtemeyer, Blue Island, Ill.; P. Peiffer, Lemont, Ill.; F. S. McKee, Stewart, Ia.; G. F. Beach, Valparaiso, Ind.; Albert Miller, Dundee, Ill.; W. W. Denny, Aurora, Ill.; M. Headman, Table Grove, Ill.; F. W. Moore, Maywood, Ill.; McIlhinney & Peterson, Lyons, Neb.; H. H. Truckenbrod, Mendota, Ill.

A. Hirsch & Co. will not move to their new quarters in the Masonic Temple until May 1st.

The Dennison Mfg. Co. will remove April 1st from 109-111 Wabash Ave. to 90-92, further north on the same street.

The Bolstad Mfg. & Plating Co. have enlarged their office room, the former quarters being insufficient for the increasing number of customers of the house.

**Cleveland.**

Frank C. Meyer, a well-known jeweler of Canton, died Tuesday evening last at the age of 40 years.

W. A. Sprague, who has been in the jewelry and optical business in Newark, O., for 25 years, has opened an optical office in the rooms recently occupied by Dr. Hatch, on 3d St., Newark.

A ten-story business, apartment and office block will soon be built at the corner of Prospect St. and Oak Place. The builder is Henry H. Johnson. The second floor will be occupied by a wholesale jewelry firm from Chicago.

**Voluntary Assignment of F. J. Essig.**

CHICAGO, Ill., March 24.—The surprise of the week in jewelry circles was the voluntary assignment, March 19, of F. J. Essig, lapidist, 1222 Masonic Temple, to his brother, Frank Essig. Four years ago F. J. Essig succeeded to the business conducted by his father, Charles Essig, for over 20 years, and in the two years past had very largely increased the business, a principal feature of which had been the cutting of Montana sapphires, in which Mr. Essig was financially interested. The past two or three months this branch of the work was considerably reduced, few orders being sent to the factory on account of a scarcity of good stones and a lessened demand consequent on a general depression of business interests. Added to this two notes fell due which Mr. Essig was unable to meet, and

he deemed it best to assign in the interest of all the creditors.

Frank Essig, the assignee, is well acquainted with the affairs of the company, having been associated with his brother as a skilled workman in the factory. The plant is one of the best, if not the best equipped in the west for lapidary work. Authorities on credit limited the responsibility of the house to small lines, but as to honesty of purpose there was no question. With increased business in general stone work and a rapid growth in the past two years came increased liabilities, and the sudden decrease of an important branch of work caught the company unprepared to meet their outstanding notes.

At this writing the assignee is at work on the books but is unable to give the figures on assets and liabilities. The failure is a small one in which principally stone men are interested.

G. E. Knight, secretary of the Rockford Watch Co., Rockford, Ill., has been appointed assistant inspector general of the Third Brigade by General Andrew Welch. His ranking on the general's staff will be lieutenant-colonel.

**OPTICAL DEPARTMENTS ESTABLISHED.**



AN EXPERT OPTICIAN will thoroughly establish an Optical Department in a limited number of FIRST CLASS JEWELRY STORES, giving his own time as promoter until on a successful basis. Will also give complete instructions in fitting to the man designed as head of the department.

**THERE'S MONEY IN IT.**

Jewelers wishing to make a special run in their optical department or establish one, will find this a rare opportunity. Your business can be increased \$1,000 to \$2,000 a month. Arrangements can be made either on percentage or salary. An unusual opportunity for a good house to

**ENTER A LUCRATIVE FIELD.**

ADDRESS

**OPTICIAN, Care JEWELERS' CIRCULAR, Chicago Office,**

**308 INTER-OCEAN BUILDING, CHICAGO.**

**JUST OUT!**

**Our New Illustrated Catalogue of . . . .**

**Watch Materials, Tools, & Jewelers' Supplies was issued MARCH 20th.**

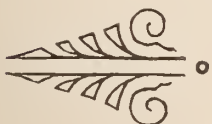

IF you have not already received a copy notify us and we will send you one at once. We wish to emphasize that our Prices will be found the LOWEST, quality of goods considered. With a well selected stock we are enabled to fill all orders promptly and correctly.

**BENJ. ALLEN & CO.,**

141-143 STATE STREET, . . . , CHICAGO, ILL.

**Watches, Diamonds, Clocks and Jewelry,**



**Assignment Follows F. G. Smith, Sons & Co.'s Financial Troubles.**

DETROIT, Mich., March 23—A voluntary assignment of F. G. Smith, Sons & Co. to Herbert E. Boynton, for the benefit of unsecured creditors, was filed yesterday afternoon with the county clerk. Mr. Boynton furnished bonds for \$250,000, with Albert L. Stephens and Truman H. Newberry as sureties.

The schedules of creditors and liabilities were not filed, but from those interested in the assignment it was learned that the assets were about \$138,000, including stock, bank accounts and fixtures. The liabilities are \$35,000 remaining unpaid on the mortgage given to trustee Robert H. Howard. The mortgage amounted to \$74,500.

The store has been closed the past week and an inventory is being taken. Assignee Boynton told THE CIRCULAR representative that trustee Howard was taking the invoice. Mr. Howard will have control of the business until his claim for \$35,000 is satisfied; then the business will be turned over to Mr. Boynton. The secured creditors repre-

sented by trustee Howard are Detroit and Pontiac banks. It is thought the firm may be able to resume business.

**Detroit.**

M. M. Ducilliard and A. S. Blyer started out for the United States Optical Co. last week.

Chas. Shiebler, of Jeannot & Shiebler, New York, paid a social visit to the trade here last week. Henry Freund, of Max Freund & Co., was also here.

Frank Kennedy, secretary and treasurer of the Johnston Optical Co., was busy last week attending to his duties as secretary of the Michigan Christian Endeavor Union that met here.

B. Buckbee, jeweler, Flushing, Mich., was here last week purchasing goods. He has patented a new method for repairing pneumatic bicycle tires, and will shortly place it on the market.

Nearly all the down town stores held Easter openings last week. Wright, Kay & Co., Traub Bros., Rolshoven & Co. and R. J. F. Roehm & Son all had their

windows filled with Spring novelties, azaleas and Easter lilies.

Business brightened last week on account of Easter. Trade with the optical manufacturers increased from 40 to 50 per cent. Collections are still poor. The following Michigan buyers were here: W. W. Bridges, Marine City; W. E. Walton, Richmond; I. E. Saunders, Carlton; Mr. Mills, of Mills & Co., Flushing; M. C. Graves, Vassar; and L. A. Steele, Linden; and William Hoep, Montpelier, O.

The following traveling salesmen passed through Detroit last week: H. C. Van Pelt, F. H. Noble & Co.; Mr. Trewin, Keystone Watch Case Co.; Everett I. Rogers, Parks Bros. & Rogers; Harry B. Kennion, H. D. Merritt & Co.; Mr. Steele, J. B. Bowden & Co.; Louis E. Smith, M. B. Bryant & Co.; W. F. Corey, Corey & Osmun; C. A. Cuppia, Ludwig, Redlich & Co.; G. P. Kaiser, Enos Richardson & Co.; Luther Hyde, Reed & Barton; Charles E. Dorr, Gorham Mfg. Co.; B. E. Osgood, Bioren Bros., F. L. Shepardson & Co. and the Essex Watch Case Co.

We lay away over them ALL for QUALITY. We have no competition in anything but price by

**The Dale.**

ALL KINDS, \$1.00.



MADE ONLY BY

**HARDINGE BROS.,**

1036 Lincoln Ave., CHICAGO, ILL.

**R. M. JOHNSON,**

IMPORTER OF

**Diamonds AND Manufacturing Jeweler,**

67 WASHINGTON STREET,  
ROOMS 5 & 6,

CHICAGO.

MASONIC EMBLEMS OF EVERY DESCRIPTION MADE TO ORDER.

**REED & BARTON,**

**SILVERSMITHS,**

MANUFACTURERS OF

STERLING *and* SILVER PLATED  
SILVER WARE.

SALESROOMS:

**37 Union Square, New York.**

34-36 WASHINGTON STREET,

**Venetian Building, Chicago.**

FACTORIES, TAUNTON, MASS.

**DUEBER-HAMPDEN WATCHES.**

Most reliable watches are the Hampden 17 Jewel. A full line of Dueber Cases and Hampden Movements. Cash buyers write us.

**BRETHAUER WATCH & JEWELRY COMPANY,**

SPECIAL AGENTS,

71 WASHINGTON ST., CHICAGO, ILLS.

**THE PLANCHAMP & BECKER CO.**

Makers and Repairers of

**WATCH CASES,**

Gold and Silver Plating —

— of Watch Cases a Specialty.

UNEXCELLED FACILITIES.

\$3 and 65 East Washington St., Chicago.

WHEN IN CHICAGO, VISIT THE

**Chicago Watchmakers' Institute,**

SUITE, 1521-1523 B MASONIC TEMPLE.

A Modern Trade School for the Watchmaker, Jeweler and Engraver.

Write for New Catalogue





**Pacific Coast Notes.**

Geo. A. Schall has bought out the store of Cook & Lee, Needles, Cal.

W. E. Steuben, Visalia, Cal., is selling his entire stock of jewelry at auction.

F. M. Judd has leased a window in Medford, Ore., and will open a repair shop.

The Wilson Jewelry Co. have opened a store at Oceanside, near San Diego, Cal.

The living insect and reptile jewelry fad is extending to the interior towns of the coast.

J. G. Donovan has opened a jewelry store in conjunction with S. G. Marschutz, optician, 167 N. Spring St., Los Angeles.

J. Glick, Stockton, Cal., is advertising that in order to meet pressing demands of creditors, he is selling goods at a bargain.

W. C. Stull, New Whatcom, Wash., is distributing 28,000 ounces of bread to the unemployed of that city, at his own expense.

F. Backstein, 1430 Market St., San Francisco, has been attached by D. Fromholz to secure \$650, claimed to be due on an unsecured note.

Edward Elias, a young Sacramento jeweler, has been committed to the insane asylum at Napa, Cal. His aberration is said to be of a mild type.

Nelson Wheelock has gone with J. P. Trafton, Los Angeles, in the wholesale jewelry business. The offices and warerooms of the establishment are now being greatly enlarged and modified.

George L. Banister, formerly a watchmaker with J. B. Wagner, Los Angeles, has succeeded to the latter's large store on S. Spring St., Wagner having opened a small store on N. Main St.

A novel and taking style of jewelry is being manufactured in Santa Monica, the famous Pacific sea coast resort, by R. H. Witheril. The material used is the beautiful abalone shell. When polished it presents a pearly, iridescent surface. He makes spoons and breast pins, which are eagerly bought by the curio-seeking tourists.

M. German, who opened a fine large jewelry store in Los Angeles about six months ago, has been forced by ill health to give up business and his stock is now being closed out at public auction. Mr. German came here from San Diego where he conducted a jewelry business on a large scale, thinking the change of climate might sufficiently restore his failing health, but he now fears that his retirement will be permanent.

O. J. Geiselman, the Benicia soldier, who sent the tray of diamonds from a cheap pack of cards to dupes who answered his advertisement to send them "a tray of diamonds for a dollar," was before Commissioner Heacock a few days ago for a preliminary examination. Before the first witness was examined Geiselman's attorney waived an examination and the commissioner thereupon held him for trial in the sum of \$2,000, in default of which he was jailed.

The following traveling men were recently in Los Angeles: Mr. Young, Wm. B. Kerr & Co.; Mr. Parker, Riker Bros.; Mr. Nathan, Rothschild Bros.; Hugo Low, Low, Weinberg & Co.; Billy Rosenberg, A. Wallach & Co.; Albert Kahn, Weis & Oppenheimer; Mr. Hammett, Whiting Mfg. Co.; G. Rodenberg, S. & B. Lederer; H. M. Peters; S. Lyon, S. Lyon & Son; Sol. Caro, Hammel, Riglander & Co.; Adolph Greenburg; George Heidig, Rumpf & Sons; Mr. Alkan, Guggenheim, Alkan & Co.

Detectives have run down and arrested a man in Los Angeles by the name of R. L. Davis, who is accused of robbing the Pacific Optical Co., San Francisco, of \$1,000 worth of glasses on Feb. 6. He had a number of articles answering the description of those stolen, and is recognized by the police as a crook well known in eastern cities under the name of Ed. Baker. His real name, however, is said to be J. C. Clark. He and a partner appear to be in quest of optical goods, as a year ago they made a big haul from a San Francisco store, and two years ago from a Chicago store.

**Columbus, O.**

John Rufensberg has returned from a visit to Portsmouth.

Miss Emma Grath, engraver with A. B. Gerlach, is visiting in St. Louis.

After April 1 the firm of Barnitz & Nune-macher will have in connection with their establishment an apartment for cut flowers, to be in charge of Miss Hattie Getz.

The Deshler National Bank last week took two cognovit judgments against the Columbus Watch Co. for \$5,001.90, each on notes given at four months, on Nov. 7th, last.

The inquest on lunacy in the case of ex-jeweler George W. Luce is in progress, and it is thought the charge will be sustained. Dr. A. B. Richardson, superintendent of the Columbus Insane Asylum, was introduced by the defense as an expert. He had called to see Mr. Luce on several occasions, representing himself to be a lawyer in the case. In this way he was supposed to have a good opportunity of examining into the case. The result of the examination of Dr. Richardson was that he considered Luce to be insane.

**CHAS. H. PFEIL,**

MANUFACTURING JEWELER.

Diamond Work a Specialty.

BEST of Workmen.  
BEST Design Work.  
GUARANTEED Workmanship.

Send a trial order and be convinced.  
182 State St., Chicago.

**HUGO MUELLER,**  
182 State St., (Room 70,) Chicago.

FINE WATCH REPAIRING  
IN ALL ITS BRANCHES.

Work for the trade promptly executed by skilled workmen.

**PARSONS : SCHOOL**

—FOR—  
WATCHMAKERS,  
PEORIA, - - - ILL.

Send for Circular and Terms.

**PARSONS & CO.**

**BOLSTAD MFG. AND PLATING CO.,**

(H. E. BOLSTAD, PRES.)

WATCH CASE MAKERS, REPAIRERS, PLATERS.  
PLATED INLAYING ON CASES.

BEST WORK. BEST WORKMEN.

170 MADISON ST., - CHICAGO.

**ELGIN HOROLOGICAL SCHOOL,**

THOROUGHLY PRACTICAL.  
COMPETENT INSTRUCTORS.

Send for Prospectus.

**ELGIN, ILL.**

**PATENT FIBRE-FACED HAMMERS.**

5 oz. for Watchmakers.  
10 oz. for Manufacturing Jewelers.  
Price 50 Cents Each.

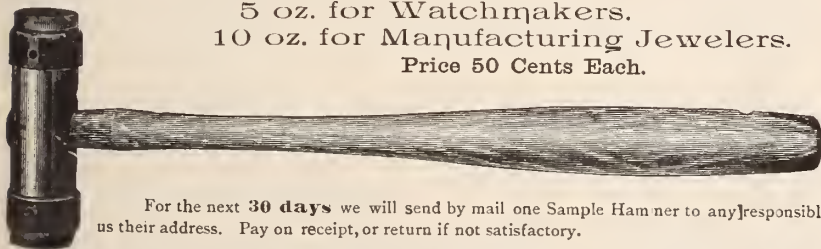

For the next 30 days we will send by mail one Sample Hammer to any responsible firm giving us their address. Pay on receipt, or return if not satisfactory.

**W. W. OLIVER, Sole Manufacturer, - Buffalo, N. Y.**

Send for our No. 10 Catalogue.



One of the best of the very best.

QUALITY IS THE STANDARD OF VALUE.

CHARGES TO SUIT THE TIMES.

When interested, write your jobber for new price list for 1894, or

**Moseley & Co., Elgin, Ill.**



No. 2 Moseley Wire Chuck has length, strength, accuracy.



Invitations are out for the wedding of Carl Barron and Miss May Brown. Mr. Barron is a jeweler with F. F. Bonnet.

There are about 30 persons engaged finishing orders at the Columbus Watch Co.'s factory under Supt. Walter Owen. Since the assignment of the company a number of former employes have entered into business for themselves. Anne & Wirschinger have opened a jewelry store at 15 E. State St. C. A. Radebaugh has opened a jewelry store at 665 High St. E. M. Radebaugh, formerly with the Columbus Co., but more

recently with the Waltham Co., has opened a millinery store. T. L. Bleile has been placed in charge of the pest house since the development of the several cases of small pox here.

### Indianapolis.

Wm. T. Marcy and wife left last week for St. Augustine, Fla.

The "When" Clothing Co. are offering special bargains in filled watch cases and American movements.

Four burglars were recently sentenced to prison for plundering the store of A. Overman, Campbellsburg, Ind.

Lynn & Teedy have bought out Frank V. Connor, Washington, Ind., and together with L. Dougherty have formed a partnership under the firm name of Lynn, Teedy & Dougherty.

Arnstine Bros. & Mier, Cleveland, O., are prosecuting Andrew Buysee, South Bend, Ind., on a charge of obtaining goods under false pretenses. Buysee has given bond.

Mark C. Davis, candidate for the Republican nomination for sheriff, was for 34 years a manufacturing jeweler and diamond setter, doing business in this city. More recently he was cashier of the order of the Iron Hall.

L. L. Norton, March 22d, filed chattel mortgages aggregating \$4,600. The mortgages cover his stock, and are in favor of L. S. and Alice Norton, Kate Burnheim and others. Mr. Norton is a wholesale dealer in tools and materials.

... THE ...

## American Horological Institute

AND TECHNICAL SCHOOL OF LANCASTER, PA.,  
LATE OF PHILADELPHIA, PA.,

A Trade School where Watchmaking is taught practically. We do not manufacture

### ☀ BICYCLES OR DYNAMOS ☀

at this institute. We confine our work strictly to WATCH WORK and its kindred branches, which include

### ≡ Engraving, Jewelry Work and Optics ≡

One tuition pays for all the branches. We do not have boy instructors at this institute, all men of years of experience. Each department has its separate instructor. Our institute is open for inspection. We kindly invite you to visit us and inspect our school modes of giving instruction and the progress that our students make by giving them practical instruction.

**THOMAS PENDERGAST,**  
PROPRIETOR AND MANAGER.

## Bell's Snaps for Cash Buyers.



Three eight-day strike and three eight day strike alarm, oak and walnut clocks, assorted, 22½ inches high, warranted, all 6 for \$11.38, net. Four inch nickel alarm clocks by the case, at 57c. each, net, warranted. Eight-day strike gong enamel clocks, 18 inch base, a "Beaut" at \$4.75 each, net.

14 kt. diamond point fountain pen, warranted, at 65c. each net. All guaranteed in price and quality, illustrations sent on request. Watches and Jewelry at proportionate rates, write for selection packages. Secure agency and one year's advertising on best line of filled cases made, sold only to one jeweler in a town.

Write us **O. E. BELL & CO.,**  
**THE BELL WATCH CASE CO.,**  
CINCINNATI, OHIO.

## GIBSON HOUSE,

CINCINNATI, OHIO.

ABSOLUTELY FIRST-CLASS AMERICAN PLAN HOTEL.

\$3.00 PER DAY.

Extra Charge for Parlors and Rooms with Bath attached. The unequalled advantages in central location, liberal management, modern appointments, experienced service and perfect cuisine, have permanently established the Gibson House as The Most Popular First-Class Hotel in Cincinnati.

AMPLE VAULTS FOR THE PROTECTION OF VALUABLES.

**THE GIBSON HOUSE CO.,**

H. B. DUNBAR

President and Manager



### Bids for the Government Clock for Lowell, Mass.

WASHINGTON, D. C., March 26.—Proposals for all labor and materials required to put in place complete a tower clock and bell for the United States post office at Lowell, Mass., were opened at the office of the supervising architect, Treasury Department, March 23d. The bids were as follows:

Seth Thomas Clock Co., New York, \$1,865, time four months.

The Standard Electric Time Co., New Haven, Conn., \$1,870, time three months.

The E. Howard Watch & Clock Co., New York, \$1,823.95, time four months. This bid was not accompanied by the requisite check, but the Department will probably consider it.

Mrs. Hicks-Lord has a Sèvres set that once belonged to the Empress Eugenie. She also has a set which was given to her by the Sultan of Turkey.

## Engravers' Type.

A Rubber Type in new styles specially adapted to Engravers' use. Seven different sizes now ready.

*Minnie S. Foster*  
*Sir Walter Scott.*

Does away with all tracing. Letters are stamped upon the article in clear cut script or old English.

The outline can readily be engraved by even the apprentice.

Type made on new principle, bevel edged; alignment guaranteed.

Every Engraver should have it. Write for particulars.

**WM. H. DIETZ,**  
117 Dearborn Street, Chicago.



**Cincinnati.**

D. Eberhardt, Dayton, O., was in Cincinnati last week.  
 Chas. Blake, Marion, Ind., has invented and patented a jewel remover.  
 H. C. Kachlein and wife, Lafayette, Ind., are making a tour of the south.  
 W. T. Marcy, Indianapolis, Ind., has returned from a trip to California.  
 Ben Martin, Logansport, Ind., has been south a few weeks for his health.  
 Peter Henry has had all the work that he can do, but he says collections are very poor.  
 John Osthoff, of Jos. Noterman & Co., has been through Indiana and reports prospects good.

Chas. Hazelton, Kokomo, Ind., has gone to Cleveland, O., to attend Dr. Julius King's optical school.

Jos. Noterman & Co. made a very fine past commander's jewel last week; they also filled an order for nine K. P. rings.

O. E. Bell & Co. are making a great run on clocks. Mr. Hodgen has returned from the road and reports very good trade.

Henry Stelpflug, one of the best diamond setters in this country, has returned from a trip to Europe to his old place with Jos. Noterman & Co.

Oskamp, Nolting & Co. had very attractive Easter window displays. They sold more Easter novelties this year than they did last year.

Homan & Co. have a full display of new goods in their new case. Among the newest are the ring stands consisting of a tray with a center rod and with three or four hooks to hang the rings on. They are among the prettiest novelties yet seen.

**Louisville.**

S. S. Lieberman has returned from a fishing trip to Indiana.

Louis Bernheim, with Leopold Weil & Co., was here last week.

Toney H. Benninger has opened a place on Market between 12th and 13th Sts., where he does repairing.

An ordinance passed by the city council prohibiting the use of swinging signs has caused many jewelers to take down their dummy watches.

Marx Kossuth, Kossuth Marx Jewelry Co., and I. Friedman, Odenheimer, Zimmern & Co., were among the traveling representatives here last week.

H. F. Kersting has bought out the store formerly conducted by Toney H. Benninger, at 18th and Market Sts. He will do a wholesale as well as a retail business. He still represents eastern firms.

**Kansas City.**

C. H. Countee will open a jewelry store in this city. He is a negro and a graduate from a horological school.

Frank Price, the Union Ave. jeweler and druggist, who failed a few months ago, has reopened his store, having made a full settlement with all his creditors.

Eugene G. E. Jaccard is one of the principals in an association composed of public-spirited business men who will secure eastern talent for a special season of grand opera in this city this Spring.

J. L. Potts, Marceline, Mo.; Joseph Sutter, Plattsburg, Mo.; T. L. Beach, Blackburn, Mo.; B. Hoffmann, Leavenworth, O.; Kohlstad, Pleasant Hill; G. H. Sherman, Paola, Kan.; J. H. and W. W. Whiteside, Liberty, and W. H. Meyer, Lawson, Mo., were among the out-of-town jewelers who visited Kansas City last week.

The police have succeeded in capturing a gang of window smashing burglars. Four of the gang are young negroes with long records as thieves and the other member is named Joseph Rosemeyer, who has

already served one term for a window theft. Rosemeyer threw a stone through the plate glass window of the Jaccard Watch & Jewelry Co.'s store a few nights ago, and stole \$25 worth of cutlery. The negroes broke the window of the store of Julius Baer, optician, and stole a lot of opera glasses.

**Minneapolis and St. Paul.**

At Glencoe, Minn., on March 13th, jeweler W. G. Gould was elected village trustee.

Benjamin & Co., Minneapolis, have started an auction clearance sale in order to reduce stock.

At the municipal election held on March 13th, at Delano, Minn., jeweler A. L. Mealey was elected city treasurer.

Mrs. Talmage Elwell, mother of J. T. Elwell, Minneapolis, died in California last week where she had gone to spend the Winter and to benefit her health.

Schneider & Co., Faribault, Minn., is the address of a new jewelry firm recently started. C. A. Schneider was formerly located in St. Paul in the jewelry business.

Out-of-town jewelers visiting the Twin Cities the past week were: L. P. Sandberg, Red Wing, Minn.; J. W. Brown, Ortonville, Minn.; C. F. Winter, River Falls, Wis.; H. A. Boreson, Ellsworth, Wis.; and Lucien Diacon, Chaska, Minn.

L. D. deMars, formerly a stockholder in the Reed & deMars Jewelry Mfg. Co., Minneapolis, has withdrawn from the firm, and has started a jewelry manufacturing plant at 329 Nicollet Ave. The new firm will be known as the deMars Wholesale Jewelry Mfg. Co., and will make all kinds of solid gold, as well as a line of rolled plate emblem goods, rings, diamond jewelry, etc.

**The Wadsworth Watch Case Co.**



Filled



Cases.



General Offices,  
**NEWPORT. KY.**

Chicago Office,  
**COLUMBUS BUILDING.**



**M. L. Read & Co. Make an Assignment.**

PROVIDENCE, R. I., March 22.—Late this afternoon Martin L. Read and Fred L. Cooper constituting the firm of M. L. Read & Co., made an assignment to Henry A. McKenney, for the benefit of their creditors. Each partner also made an individual assignment to Mr. McKenney. The assignment was made under peculiar circumstances and as the assets exceed the liabilities, Mr. Read hopes to be able to pay dollar for dollar.

The firm was established in 1879 when Mr. Read with Thomas J. Gardiner commenced as Read, Gardiner & Co., at 25 Potter St. In a few years their business had grown to such an extent that the firm required larger quarters and consequently removed to 227 Eddy St., where they remained for several years. After a few years the firm dissolved, each partner continuing for himself. In September, 1887, Mr. Read became interested in Hudson, Farnum & Co., but this style was soon changed to M. L. Read & Co., and at the time of the great fire on Washington, Eddy and Fountain Sts., the firm was burned out, leaving Mr. Read out of business for a time.

In May, 1888, Mr. Read again engaged in business as M. L. Read & Co., the company being nominal, Mr. Read remaining alone and doing an excellent business, amounting to some \$25,000 a year, up within about two years. In October, 1892, Mr. Cooper entered the firm. In September last \$2,000 was borrowed of a friend of the concern, and in December \$500 more was borrowed, and as security the gentleman was given a mortgage upon the firm's property, which was not registered until a few days ago.

In December last the firm made arrangements to send a large exhibit to the Mid-Winter Exposition in San Francisco, and \$4,000 worth of goods was made up and sent there. This left the firm without any ready capital, but returns were expected, and plenty money was due the firm with which to pay the help. A man named A. Ryan, employed by the firm, seemed anxious about

the amount due him, \$28, and placed an attachment upon the firm. Feeling that if this attachment was satisfied other claims would be pressed, to the embarrassment of the firm, it was decided to make the assignment. The liabilities of the firm are between \$4,000 and \$5,000, including the mortgage of \$2,500, while the assets are fully \$7,000. The assignee will begin taking an inventory of the stock at once, and, as a majority of the creditors are in this city, a meeting will be called in a few days, and it is thought that a satisfactory settlement can be made in a short time and the firm be able to resume.

**Jeweler Peters Makes a Brave Capture of a Daring Burglar.**

WASHINGTON, D. C., March 21.—Yesterday morning about 4 o'clock the smashing of a pane of glass in the window of Harry W. Peters' jewelry store, 1721 7th St., aroused the proprietor, who in endeavoring to ascertain the cause therefor discovered a man engaged in a bold attempt at robbery. The electric light made the street as bright as day, and Mr. Peters saw at a glance that the burglar was at work. Through the hole in the glass the burglar was poking a long wire, making an earnest effort to gather together several watches and chains. Mr. Peters followed his movements, as well as those of a man on the opposite side of the street, who was watching for the police. Getting his pistol and slipping on part of his clothes, Mr. Peters made his way to the street, and finding no officers of the law about, he started to play policeman himself.

The burglar made a bold dash for liberty when Mr. Peters notified him by his presence that he was his prisoner. Mr. Peters followed and discharged his weapon several times, causing considerable excitement, but he failed to attract a policeman. On 6th St. he overtook the man and placed him under arrest. On the way to the station he met a policeman to whom he handed over the prisoner. The wire used at the window was found in the street.

Harry Thorn was the name given by the

young man. His alleged accomplice was in court the next morning but when he saw the jeweler he departed. Thorn was given a hearing on a charge of burglary. He said the other man was a stranger to him and he met him a short while before he went to the store. Thorn was committed to jail.

**G. W. Gilbert Settles With the H. M. Betz Jewelry Co.**

POTTSTOWN, Pa., March 23.—G. W. Gilbert, who recently became manager of the store of the H. M. Betz Watch & Jewelry Co., 259 High St., and who some weeks ago instituted legal proceedings against the company for an alleged fraudulent mortgage of \$3,000, has effected a settlement of his differences with the company. By the terms of settlement, the company return the mortgage to Mr. Gilbert and the latter purchases the stock, together with some of the fixtures of the store.

Mr. Gilbert will dispose of this stock as soon as possible and in future devote all his energies to the profession of music.

**Death of Jacob S. Wagner.**

POTTSTOWN, Pa., March 23.—Jacob S. Wagner, a well-known citizen, died Tuesday morning, after an illness of two and a half weeks with typhoid fever, aged 53 years and 3 months. His wife survives him.

Mr. Wagner was a jeweler by trade and engaged in that business at Schwenksville. Then he went to Bechtelsville and did a general store business, with his brother Jonas S. Wagner. Seven years ago these two brothers moved to Pottstown within a few months of each other. They are owners of the Wagner building, on High St. near Washington. Funeral services were held to-day.

The death occurred a few days ago of Liberty Phelps, a retired business man of Southbridge, Mass. He was born in Thompson, Conn., in 1816, and many years ago was in the jewelry business in Southbridge.



# \$500 Reward

will be paid by the undersigned on delivery to the police authorities in New York, of

## SIMON M. JACOBS,

who is wanted for grand larceny. Age about 30 years, 5 ft. 7 inches in height, medium build, has dark hair and eyes, dark sandy moustache, dresses nobbily, was a traveling Diamond Salesman, and lately Life Insurance Agent, is considerable of a sport, visiting race tracks and pool rooms.

SCHULZ & RUDOLPH,

24 John Street.

LUDEKE & POWER,

23 John Street.



**Connecticut.**

S. Bondy, Hartford, has decided to withdraw from business and is selling his large stock.

The clock shops in Thomaston have resumed work on a schedule of five days a week, eight hours a day.

E. Houseworth, optician, Philadelphia, was at the jewelry store of W. R. & E. H. Rowe, New Haven, Thursday.

W. C. Barry & Co., of Danbury, having closed their jewelry business, Mr. Barry has taken position with Crofutt & White of that city, as traveling salesman.

Frank H. Cushing, secretary of the Meriden Silver Plate Co., has returned from Ashtabula, O. His engagement to Miss Hattie Morgan, of that place, is announced.

Simpson's nickel works, Wallingford, which have been running four days a week for several months, have begun on a five day 10 hour schedule. Business is improving with the company.

F. L. Rogers and S. S. Osborne, of Bridgeport, stockholders of the Biggins Silver Co., and H. E. Biggins were in Wallingford, Tuesday and Wednesday and reported the affairs of the new concern as progressing most satisfactorily.

Corporation returns: Rogers & Hamilton Co., Waterbury, capital, \$50,000; real estate, \$1,500; personal estate, \$180,000; debts, \$70,000; credits, \$30,000; Manhattan Watch & Jewelry Co., New Haven, capital, \$7,000; personal estate, \$16,960; debts, \$14,202; credits, \$7,816.

The late Samuel Wilmot, of Bridgeport, the veteran retired jeweler, died without leaving any will. Application has just been made in the probate court for the appointment of an administrator for the estate and Horace S. Wilmot was appointed by the court. His bonds were fixed at \$10,000. The estate is estimated to be worth from \$35,000 to \$40,000.

Ex-Chief of Police Charles F. Bollman and Attorney Jacob P. Goodhart, commissioners on the insolvent estate of Moses Frank, watchmaker and jeweler, 346 State St., New Haven, submitted their report of claims allowed, to the probate court Saturday afternoon. The general claims allowed amount to \$680.02 divided as follows: Adolph Goldsmith, New York, \$430.03; Max Freund & Co., New York, \$225.14 and Burns Mfg. Co., Providence, \$24.85. No preferred claims were allowed.

THE JEWELERS' CIRCULAR observed its silver anniversary with its February number, an elegantly illustrated 150 page paper filled with interesting matter connected with the trade in all branches.—*Courier*, Boston, Mass.

**Death of a Veteran Watchmaker.**

PROVIDENCE, R. I., March 22.—Thomas Windle, an old watchmaker of Dorrance St., was taken suddenly ill in his store yesterday afternoon and before reaching his home expired. Yesterday morning Mr. Windle, who is 67 years old, was apparently in good health when he opened the store. At noon he felt slightly ill, but nothing serious was thought of the matter. He went to and returned from dinner, and about 2 o'clock was taken suddenly ill at his bench.

The deceased was a watchmaker of the old school and was a thorough jeweler. He had occupied the store in which he was taken ill since 1867.

The New Haven Silver Plate Co., Lyons, N. Y., are running overtime. The Manhattan Silver Plate Co. have also been compelled to run overtime, and A. H. Towar has been working the contractors as fast as possible so that he may start up with his silver plating factory by the first of April.

**GOOD TIMES ARE COMING.**

Enliven your stock and set the ball rolling by putting in a line of the new "CHARMILLES" watch.

HIGHEST ART,  
GREATEST VALUE,  
LEAST MONEY.

FOR PARTICULARS AND PRICES ADDRESS YOUR JOBBER.

**THOMAS W. LIND, Manufacturer of Jewelers' Findings,**

67 FRIENDSHIP STREET, PROVIDENCE, R. I.



FULL SIZE NEW ROCOCO.



*Settings Made in Any Desired Thickness of Stock.*

Call or send for samples of my New ROCOCO PATTERNS, for Picture Frames, Cane Heads, Whips, Boxes, Napkin Rings, etc.

Large Assortment of TRIMMINGS for Millinery Ornaments, Scarf Pins, etc



**Trade Gossip.**

Fine diamond jewelry is a specialty with Paul Jeanne, 18th St. and Broadway, New York.

Codding Bros. & Heilborn, N. Attleboro, Mass., offer a most artistic line of sterling silver novelties, many exclusively their own. The line will well repay inspection. Chicago office, 103 State St.; New York office, 178 Broadway.

Geo. W. Baker, the refiner, of Providence, R. I., wants only one trial shipment to demonstrate the fact that he means what he says when he claims that his returns on old gold, silver, sweeps, etc., are the best. T. J. Gardner represents Mr. Baker on the road.

The new clock staff wrench No. 529, offered by O. W. Bullock & Co., Springfield, Mass., is an entirely new and useful tool for setting up clocks, particularly fine and costly ones.

Once engaged with a staff, either for removing or replacing, the tool cannot slip. The tool is made of fine steel and is warranted.

One of the latest of the many beautiful silver novelties for which the Alvin Mfg. Co., 860 Broadway, New York, have become favorably known to the trade, is a cologne bottle covered with electro deposit tracery of pure silver ( $\frac{1000}{10000}$  fine). Its beauty, as well as moderate price, is creating for this novelty a demand almost unrivaled among the silver specialties introduced this year.

The approach of May with its many removals and renovations in offices, is always the cause of a sudden but considerable demand for new office furniture. Wm. Schwarzwaelder & Co., corner Fulton and Pearl Sts., New York, probably have this in mind when they call the attention of the jewelry trade to the large assortment of office desks and chairs which they manufacture.

A California souvenir spoon, commemorative of the Mid-Winter Exposition, is among the recent products of the Campbell-Metcalf Silver Co., Providence. On the obverse side of the handle the design includes the representation of the rising sun, partially surrounded by scroll work; below this are arranged representations of various kinds of fruits. At a lower point is a representation of a bear, while the shank of the handle near its junction with the bowl carries the representation of a pioneer gold miner. The design includes the view on the reverse side of the handle the Cliff House, San Francisco; San Gabriel Mission, Los Angeles; the Golden Gate, and the Lick Observatory, all combined with suitable scrolled devices. At intervals spaces are provided for inscriptions. A patent on the design was issued two weeks ago to Ernest W. Campbell.

Mention has already been made in these columns of McIntire, Ulmer & Co., Philadelphia, Pa., a new firm of manufacturing and jobbing opticians. Mr. McIntire will be remembered by the trade as the gentlemanly and efficient head of the prescription department of the Philadelphia Optical & Watch Co., while Mr. Ulmer is widely known as traveling representative for the same concern. G. W. Magee and Edgar A. Brown, the remaining members of the firm, both have well established reputations as men skilled in their profession, Mr. Magee as a valued prescription clerk in one of the leading optical stores of the city of Philadelphia, and Mr. Brown as foreman of the manufacturing department of The Philadelphia Optical & Watch Co. The young firm is established on a good basis and as its members are both skilful and enterprising we bespeak for it a bright future.

F. W. Schuler and W. T. Beans, two capable instructors in watch and clock making, who until recently conducted classes in other horological schools, have recently founded and are conducting the Philadelphia College of Horology. The

**DIAMONDS.**

**Wm. S. Hedges & Co.,**

**Importers of Diamonds,**

And Manufacturers of DIAMOND JEWELRY.

**170 Broadway, New York.**

22 Holborn Viaduct, London.

**R. A. KIPLING,**

Importer of

**PRECIOUS STONES,**

**21 & 23 Maiden Lane,**

19, RUE DROUOT,  
PARIS.

New York.

**THEODORE C. STEINHAUS,**

— MANUFACTURER OF —

**Fine Cases and Trays**

For JEWELRY, SILVERWARE, &c.

SAMPLE CASES AND TRAYS FOR TRAVELERS.

Fancy Hard Wood Chests for Silverware, &c.

Linings, Cushions, Mounting, etc., for Silver Novelties.

**10 MAIDEN LANE, NEW YORK.**

**Alfred H. Smith & Co.,**

IMPORTERS

DIAMONDS

AND

PRECIOUS STONES,

**182 BROADWAY, COR. JOHN STREET,**

**NEW YORK.**

22 Holborn Viaduct, London, E. C.

**OPPENHEIMER BROS. & VEITH,**

**WATCHES AND**

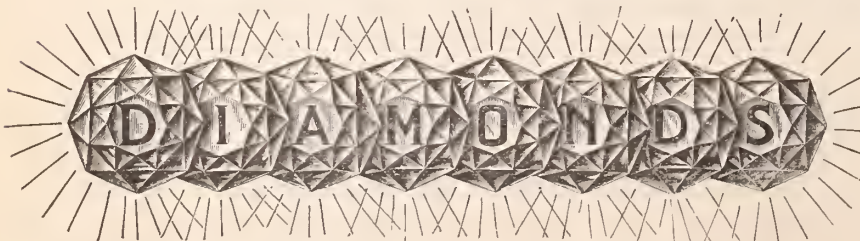

**DUEBER CASES. HAMPDEN MOVEMENTS.**

AMSTERDAM, HOLLAND, 2 TULPSTRAAT.

LONDON, ENG., 28 HOLBORN VIADUCT.

NEW YORK, 35 MAIDEN LANE.



college is located in the Heed office building, Filbert St. near 12th St., in the very center of the business portion of Philadelphia, one of the safest and most convenient buildings in that city. Having sufficient capital and an abundance of energy Schuler & Co. have fitted their college with every approved appliance that would be of advantage to the student and have spared neither pains nor expense in securing an efficient corps of instructors. The full course embraces everything pertaining to the making and repairing of watches and clocks.

An elaborate and attractive optical exhibit at the World's Fair was that of S. Lubin, Philadelphia, and Baltimore. The exhibit consisted of a perfect miniature model of the Lubin optical manufacturing plant in Philadelphia together with an interesting collection of ancient and modern optical goods. In connection with the exhibit was an examining and testing department, in charge of an expert, which was shrewdly put to most profitable account. The number of eyes tested and prescribed for ran into hundreds, each case being carefully recorded in a book kept for the purpose. Now the orders for the glasses prescribed for at the World's Fair are coming in so fast that it requires two clerks to attend to the mailing and an extra force of workmen to make the goods. Mr. Lubin will make a fine exhibit at the exposition in Antwerp, next Summer.

Why is it that the eyesight of school children is neglected to such a great extent? Hundreds of myopes and hyperopes are allowed to squint and blink through the day's session, as well as studying at home, with print six to eight inches from the eyes. In some cases myopia, in others, strabismus, and often serious astigmatic errors are allowed to go uncorrected until the strongest lenses are required. Many painful operations could be avoided by the "stitch in time," especially in hyperopic cases. A qualified optician should issue an eye opener to the parents in the shape of a public letter of practical advice in this line. If you are not an optician, you should attend a course of instruction, such as is given in the monthly session of the Spencer Optical Institute, 15 Maiden Lane, New York, and become qualified in this branch.

Paper weights are extremely varied in shape and decoration. One exhibits a snake in vari-colored enamel entwined around the stump of a tree resting in a bent position on a rugged ground. Others show a bear of silver, worked so as to make the fur look natural; a lion, a tiger, a pointer, etc., or a naiad in snow white silver, laying in a shell of brown gilt; a Diana of a smoked topaz, standing on a rocky ground of oxidized silver. A great many are in rock crystal, of a flat oval shape, variously adorned with a chased gold covering in pierced work.—*Paris Note.*

ESTABLISHED 50 YEARS.

RANDEL, BAREMORE & BILLINGS,

IMPORTERS OF

DIAMONDS,

AND OTHER PRECIOUS STONES.

FINE PEARLS A SPECIALTY.

MANUFACTURERS OF

DIAMOND JEWELRY,

IN THE LATEST DESIGNS.

Diamonds Recut in Modern Styles or Repaired on Premises.

58 Nassau Street,  
29 Maiden Lane  
NEW YORK.

1 Tulp Straat,  
AMSTERDAM.

1 St. Andrews St.,  
Holborn Circus,  
LONDON, E. C.



TRADE MARK.

ESTABLISHED 1841.

CARTER, SLOAN & CO.,

MANUFACTURERS OF GOLD JEWELRY,

No. 15 MAIDEN LANE.

NEW YORK.

A. CARTER, JR.  
A. K. SLOAN.  
C. E. HASTINGS.

GEO. R. HOWE.  
WM. T. CARTER.  
WM. T. GOUGH.

FACTORY, NEWARK, N. J.



JOHN N. DISSELKOEN,  
Cutter and Importer of  
**DIAMONDS**  
FACTORY,  
76 LANGBLEEKERSPAD  
AMSTERDAM.  
19 East 16th St.,  
NEW YORK.

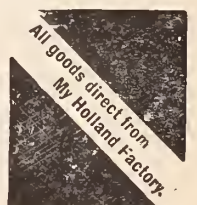



## SUGGESTIONS FOR WINDOW AND STORE DECORATION.

Members of the trade who think they have an attractive window are invited to send us a photograph, or a pen and ink or pencil sketch of the same, which will be published if we consider the window contains any originality or lesson.

### IDEA LXIX.

**D**URING the carnival lately held in Quebec, the window of P. E. Poulin & Co. attracted a crowd around it during the whole week, it being so natural in every detail in its depiction of a Canadian backwoods pioneer log cabin. The scene was supposed to represent a party of hunters passing the cabin on snow shoes, dragging

Theo. Dilger, Pulaski, Va., has anticipated Pulaski's good fortune in securing the court-house and jail and has placed in his show window a very well gotten up model of a court house and jail. Mr. Dilger's purpose is to fold; he wishes to direct the public mind in the right channel and also wants to teach them never to try to resist the

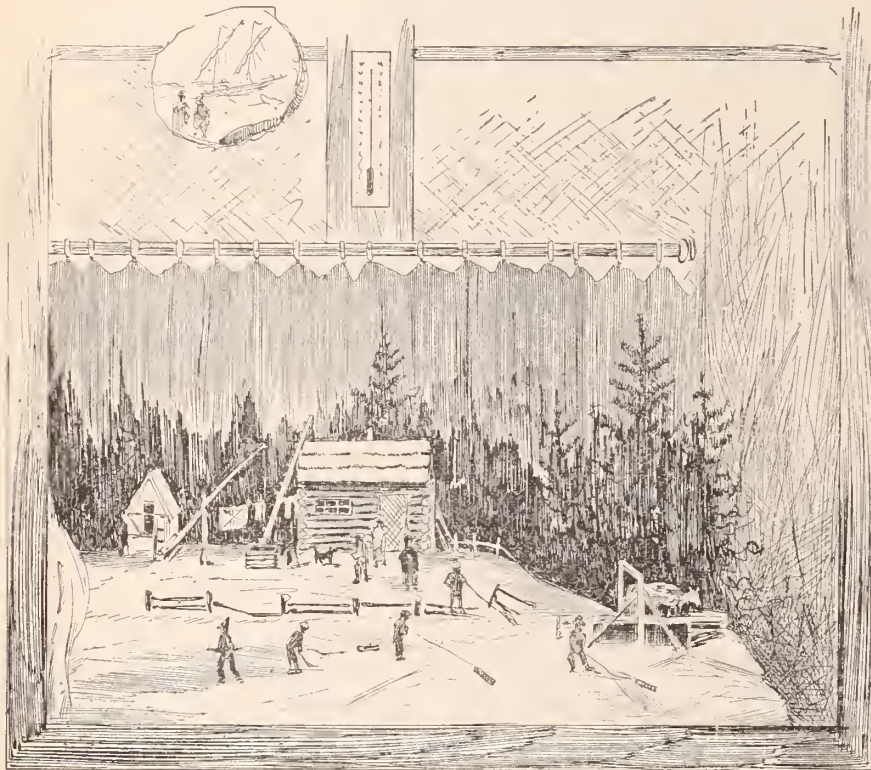

A PIONEER SCENE AS A SETTING FOR A JEWELRY DISPLAY.

their toboggans with their camp supplies, on their way to the woods, while the settler and his family have come out to speak to them. It was a typical scene of the locality, the elements being the frame bridge with the bull harnessed to a sleigh, the pile of wood alongside of the cabin, five or six children, the "clay oven," the cross stick well, logging sled and the one horse barn.

The only jewelry shown was the silver snow shoes worn by the hunters and the silver toboggans.

The back and sides of the window were lined with spruce trees, while canton flannel was arranged to look like snow.

### Show Window Concepts.

G. M. Keller, jeweler, Lockhaven, Pa., recently displayed in his show window a miniature bale of cotton that had been sent to him by mail from a friend 'at New Orleans.

inevitable. The right channel is that the court house in reality should be in Pulaski. The inevitable is that the people of the county will put the court house and jail at Pulaski and that the people will purchase all of their silverware and jewelry at Dilger's.

The show window of J. E. Eckert's jewelry store, Marengo, Ia., presents a most attractive appearance every evening now. He has contrived a clock work machine whereby colored electric lights are alternated about every two seconds.

In the show window of Jenkins' store, Richmond, Ind., is a sight good for sore eyes, being a collection of about 200 gold coins of the realm, ranging in value from 25 cents to \$50. They are the property of the old gentleman and he has been many years in collecting them.

## Finding Turquoise in Victoria.

**T**HE discovery of the true turquoise in Victoria has given rise to a new phase of the mining industry there, from which important results are anticipated, says the Melbourne *Argus*. The pioneer in the movement is a man named Gascoigne, who from the year 1879 to 1888 was a member of the Victorian mounted police force. He had a hobby for collecting specimens of minerals from the various districts he visited, and when stationed at Hedi, in the King River district—a locality which was formerly the hunting grounds of the Kelly gang of bushrangers—he became acquainted with a young man named Edward Burke, a thorough bushman, of whom he one day inquired if he had ever come across traces of gold there. Burke replied that he had not, but a year previously he had found on the hills, 12 miles away, a pale blue stone in veins in the rock, and nobody seemed to know what it was. Gascoigne became interested, and in September, 1888, the two set off to the place together.

On arriving there they commenced their search, but Burke speedily left Gascoigne alone, while he followed up the tracks of some wild horses he had come across. Gascoigne persevered in his search, and at last found a large outcrop of gray slaty rock, in which there was a blue vein. With his clasp knife he took out a number of pieces of the blue stone which Burke, on returning from his pursuit of the horses, recognized as the same sort he had picked up a year before. No one at Hedi could say what the stone was, and even the Sandhurst School of Mines and the secretary for Mines, Melbourne, reported that it was of little or no value. But Gascoigne still had faith in the discovery, and when he visited Melbourne later on the stone was thoroughly tested by an Italian expert, who found it to be the true turquoise, a judgment which has since been thoroughly confirmed.

Two mining leases were then secured; the Hedi claim was worked by a company and the New Discovery claim by P. C. Gascoigne in conjunction with his brother, E. C. Gascoigne, and a German lapidary named Becker, who thought so much of the find that he gave up his business in Melbourne in order to join in the work. They had little capital, but they worked hard for some months to raise a consignment for Europe, where they hoped to secure a market. Favorable returns came to hand, and one firm gave an order for a large quantity to be forwarded for cameo cutting, but just as the greater portion had been dispatched a cablegram arrived stating that cameos had all at once gone out of fashion, and countermanding the order.

But the prospects have now greatly improved; shafts have been sunk 40 or 50 yards in order to reach a depth where it is expected stone will be found "equal to the finest the world can produce;" other claims are being taken up, and there is good reason for believing that before long turquoise from



Australia will be competing in European markets with those that have been found from time immemorial in the famous mines of the Persian province of Khorassan.

**Boston.**

J. Pond, formerly with the American Waltham Watch Co., has located in West Upton, Mass.

Edward E. Hardy, of D. C. Percival & Co.'s establishment, writes from Georgia that he is having an enjoyable outing in the southern paradise.

M. L. Carter & Co. will open a business in Danbury, Conn., as jewelers and silver-smiths. Mr. Carter was formerly with Smith & Patterson, of this city.

Charles Orme and Fred C. Hight, formerly in the employ of William A. Thompson, have formed a partnership under the firm name of Orme & Hight, and located at 8 Bromfield St., as manufacturing jewelers.

Manager Rufus B. Carr, of the E. Howard Watch & Clock Co., is in New York on business. The clock factory is now working full eight hours time, six days a week, instead of five, as had been the case for some weeks hitherto.

**The Attleboros.**

F. W. Northup has started the manufacture and designing of prize medals, in Plainville.

Several young men of Attleboro are planning the formation of a co-operative company for the manufacture of small silver novelties.

Miss Florence Maintien, daughter of the late J. B. Maintien, and Charles H. Parker, a bright young Wrentham jeweler, were married Thursday.

The annual Attleboro election was held Monday. John T. Bates was elected town clerk and treasurer; G. A. Dean, water commissioner; G. A. Adams, D. H. Smith and Charles Phillips, selectmen. For the seventh successive year the town went no license.

The annual grand ball of Company J, 5th Regiment, was held Friday evening. It was the great social event of this section, and among the officers of the ball were: H. A. Clark, W. H. Goff, W. F. Maintien, E. H. S. Horton, S. O. Bigney, L. A. Blackinton and J. E. Blake.

Between 2 and 3 o'clock Saturday morning the residences of William Fisher, of W. N. Fisher & Co., and Benjamin Stanley, of Stanley Bros., were burglarized. Mr. Fisher lost about \$100 in cash, nearly as much in silverware and several highly valued souvenir coins. Mr. Stanley's loss did not exceed \$75.

**Springfield, Mass.**

Mrs. Goodman, owner of the block in which F. A. Hubbard's jewelry store is located, is planning some alterations to the front of the block which will make it much more convenient. She proposes to build out

the show windows of the different stores, including Mr. Hubbard's and deepen them, beside substituting plate glass for that now in use.

M. F. Robinson, the Main St. jeweler has advertised that he is going out of business and proposes to sell his stock at auction. The reason for the retirement is that Mr. Robinson is called upon to vacate his present store by April 15th, and being unable to find another suitable store on Main St., he has decided to close out his entire stock. He has been in business here for many years and has had a pretty good class of trade.

**Philadelphia.**

W. H. Hansell made a business trip to New York last week.

E. L. Emery, Jr., Bradford, Pa., made a circle of the local trade, last week.

The Bailey, Banks & Biddle Co. opened a magnificent silver exhibit last week.

Mr. and Mrs. George W. Scherr have been spending a week at Atlantic City.

A. E. Bates, watchmaker and jeweler, has opened an office at S. E. cor. 13th and Chestnut Sts.

Benj. Allen, head of Benj. Allen & Co., Chicago, spent several days among Philadelphia friends last week.

On Thursday last a sneak thief went into the store of James Orr, 2031 Germantown Ave., and stole four gold watches valued at \$140.

In a fire at 709 Sansom St. last Wednesday night, the business of Knauss & Zindel, manufacturing jewelers, was damaged slightly by water.

Simon Muhr purchased the Prince of Wales box at the Academy of Music for \$250, for the first performance of the Wagner Festival in aid of the unemployed poor.

J. Albert Koons, 1827 Ridge Ave., made an assignment on Saturday for the benefit of his creditors to William B. Davis. The deed conveys no real estate, and the amount involved is believed to be so small that the assets will easily meet it.

Jacob Garber and Walter S. Chattin, who are well and favorably known through their connection with prominent shops in the city, have opened a factory for the manufacture and repairing of fine jewelry and for precious stone setting at 127 S. 8th St.

What is said to be the first cuckoo clock made in this country for the trade is now on exhibition in the window of Breiting & Kunz, importers and manufacturers of horological goods and music boxes. It is enclosed in a beautifully carved oak case and besides a perfectly working cuckoo has a fine music box within, which plays a tune every hour. The firm propose to engage in the manufacture of these clocks for the trade.

Emma Bailey, the youthful adventuress and swindler, pleaded guilty on the 19th inst. before Judge Biddle, to the larceny of

a diamond ring valued at \$110, the property of jeweler Wm. G. Earle, 11 and 13 N. 9th St., and of a pair of opera glasses valued at \$10 from Henry S. Williams. There were other charges of a similar character against her, but they were not pressed. The young woman was sentenced to an imprisonment of three years.

An attachment under the fraudulent debtor's act was on Thursday issued from the Common Pleas Court by the Sansom Cutlery Co. against N. J. Tichenor & Co., to recover a debt of \$2,886.84 for goods sold and delivered. The firm assigned the same day for the benefit of creditors, the cause being the general financial depression. Mr. Tichenor confessed judgments amounting to \$6,000 or \$8,000. The total liabilities amount probably to \$30,000 with assets of about \$10,000.

**Newark.**

Van Houten Bros. have given a chattel mortgage on machinery to A. Lelong for \$5,780. The Van Houten Bros. Jewelry Co. have given a chattel mortgage for \$5,941 on stock to E. Van Houten.

Some time ago Michael Eggert bought a watch of jeweler Jean Tack on the instalment plan. Eggert made a number of payments, but recently he pawned the time-piece. When jeweler Tack heard of this he had Eggert arrested for misdemeanor. Judge Preisel paroled him last week.

Thomas Benfield, of the Keller & Untermeyer Mfg. Co., is the principal projector in the development of a supposed gold and silver mine in Morris county, at a place known as Jacksonville. The speculators have secured 300 acres of mountain, meadow and farm land at that place.

The funeral of Stephen Pierson Mockridge was held at his home Wednesday morning, a large number of relatives and friends attending the service. The body was buried in Mount Pleasant Cemetery. Mr. Mockridge was one of the oldest manufacturers of this city, having started in the jewelry business in 1844. He built up a large and prosperous business, but met with reverses in the panic of '73, from which he never fully recovered. He was born in this city in 1823, and was a son of Elihu Mockridge.

**James G. Thompson & Sons Succeeded by a Corporation.**

STOUX CITY, Ia., March 20.—The articles of incorporation of the Thompson Company have been filed. The company are to have \$20,000 authorized capital and to engage in the jewelry business. They may begin business when \$10,000 of the capital is paid up.

The incorporators are F. M. Case, F. M. Ferris and F. C. Swan, who also constitute the provisional board of directors. The company will continue the jewelry business of James G. Thompson & Sons, and the members of the old firm will have charge of the store.



## Our Traveling Representatives



Traveling representatives may consider these columns open for the publication of any news or items of interest regarding themselves or their conferees.

**T**RAVELING men visiting Davenport, Ia., jewelers, the past week were: A. J. Sherrard, Enos Richardson & Co.; C. S. Shepard, C. G. Alford & Co.; F. W. Bliss, Unger Bros.; C. M. Davis, New Haven Clock Co.;

D. I. Byers, Cincinnati Refining Co.; G. H. Linton, F. M. Whiting & Co.; R. D. Dirksen, Dirksen Silver Filigree Co.

C. F. Livermore, Middletown Plate Co.; Geo. F. Heidet, C. F. Rumpf & Sons, and Norbert Gunzburger, Norbert Gunzburger & Co., will visit Kansas City this week.

J. C. Moreland, with Lapp & Flershem's lines, left for the northwest, Thursday, and R. W. Barlow, for C. H. Knights & Co., departed for the southwest Monday last.

The following traveling men were in Kansas City last week: Mr. Stone, Shafer & Douglas; A. E. La Vigne, Mathey Bros., Mathez & Co.; A. M. Weinberg, Low, Weinberg & Co.; F. H. Carpenter, Alfred H. Smith & Co.; S. T. Seal, Wm. Rogers Mfg. Co., and Maltby, Henley & Co.; Mr. Van Houten, Sinnock & Sherrill.

"Commodore Coutts is on the road and is doing finely," said G. A. Webster, Chicago. "We have done double the business this month we did in the corresponding month a year ago, and there is a steady increase." The reason assigned by Mr. Webster was that business houses were buying more freely, and also the fact that the firm were putting many new goods on the market.

Eastern jobbers and manufacturers represented in the Twin Cities, the past week were: Waite, Thresher Co., by E. L. Mumford; Meriden Britannia Co., by W. C. Wood; Sinnock & Sherrill, by Mr. Van Houten; Foster & Bailey, by J. A. Limbach; Simpson, Hall, Miller & Co., by F. W. Adams; Max M. Kolliner; Providence Jewelry Co., by Mr. Rivers; I. B. Miller Jewelry Co., by Mr. Miller.

Among traveling representatives in Philadelphia the past week were: Wm. Wightman, R. F. Simmons & Co.; R. Blake, Blake & Claffiu; R. Robinson, R. Robinson & Co.; L. Blackinton, W. & S. Blackinton, Ed. Eckfeldt, W. B. Kerr & Co.; Wm. Tarlton, Wightman & Hough Co.; Sig. Schiele, Wallach & Schiele; S. Kent, Wm. H. Ball & Co.; Ed. Ackley, Unger Bros.; J. E. Simonson, A. J. Hedges & Co., and Jas. Richards, of J. J. & J. M. Richards.

S. N. Jenkins completed arrangements the past week to represent A. Wittnauer, New York, in the western territory, with

headquarters at 42-44 Madison St., Chicago. Mr. Jenkins has a complete line of this well known firm's importations. Besides being manager of the Chicago agency for Aikin, Lambert & Co., Mr. Jenkins has the agency for F. Kroeber Clock Co. Speaking of the watch line, he remarked: "I sold the watches for twenty years and think they are the best made. They easily lead all lines of complicated watches."

The following traveling representatives were in Indianapolis, Ind., last week: C. S. Shepherd, Roy Watch Case Co.; H. A. Tibbals, Wilcox Silver Plate Co.; C. H. Grout, Geo. F. Greene & Co.; H. E. Vincent, Simpson, Hall, Miller & Co.; C. F. Willemin, H. Muhr's Sons; A. H. Oakley, Thornton Bros.; Mr. Bosworth, Potter & Buffinton; Mr. Ettinger, Keller, Ettinger & Fink; I. Friedman, Odenheimer, Zimmern & Co.; W. P. Hanford, Roseman & Levy; F. Phillips, A. & J. Plaut; A. Totten, Rogers & Bro., and representatives of Reed & Barton and E. L. Spencer & Co.

Among the travelers who visited their Boston customers the past week were: Irving Smith, Crescent Watch Case Co.; Harry F. Barrows, H. F. Barrows & Co.; Allan S. Farwell, Geo. Chase & E. Horton, J. B. Bowden & Co.; Fred S. Gilbert; H. Freese, Lewis, Kaiser & Luthy; Otto Wormser, Henry Dreyfus & Co.; T. F. Fessenden; M. Herzog, Peckham Seamless Ring Mfg. Co.; Chas. H. Barney, Middletown Plate Co.; A. Barker, Meriden Britannia Co.; H. W. Dunham, Meriden Silver Plate Co.; George T. Paine, E. I. Franklin & Co.; Henry G. Thresher, Waite, Thresher Co.

Representatives of eastern houses visiting Chicago seem happier than for many moons past. Among those smiling last week were: Joe Fowler, Fowler Bros.; G. H. Coggsill, Geo. L. Vose & Co.; Frank B. Lawton, S. B. Champlin & Son; F. C. Somes, Marsh & Bigney; L. H. Bosworth, Potter & Buffinton; C. C. Darling, L. W. Pierce & Co.; W. S. Green; S. A. Bennett; W. W. Middlebrook, B. A. Ballou & Co.; Mr. Dorchester, Brown & Dorchester; Charlie Fraser, Hancock, Becker & Co.; T. G. Frothingham; Ernest Block, W. & S. Blackinton; Mr. Van Houten, Sinnock & Sherrill; C. L. Joralemon, A. Joralemon & Co.; Mr. Hutten, Geoffroy & Co.; C. F. Willemin, H. Muhr's Sons.

Traveling men favoring the Syracuse trade with a call the past week were: C. F. Friedholdt, The Springfels Mfg. Co.; A. A. Wood, Howard Sterling Co.; A. G. Watts, Rogers & Brother; Hugo Baer, for Wm. I. Rosenfeld; E. P. Hutten, Geoffroy & Co.; Wm. G. Nerpel, Nesler & Co., and F. F. Felger; Monroe Engelsman, for Maurice Weil; A. T. Sansbury, Hayes Bros., C. B. Lawton, Dennison Mfg. Co.; W. L. Washbourne, Ludwig, Redlich & Co.; C. L. Bleecker, Wm. S. Hedges & Co.; C. M. Dillon, Meriden Cutlery Co.; E. Jacobson, Jacobson Bros.; C. E. Barber, Gorham Mfg. Co.; Mr. Metcalf, R. Blackinton & Co.; F. S. Sherry, Jos. Fahys & Co.; A. M.

Stevens, H. Muhr's Sons; Oscar Stern, Hammel, Riglander & Co.; W. H. Lee, W. E. Webster & Co.; S. D. McChesney, Wm. B. Kerr & Co.; Wm. Egerton Bliss, The Meriden Sterling Co. and E. A. Bliss & Co.; Mr. Heffron, Riley, French & Heffron.

The following letter is self-explanatory:  
NEW YORK, March 26, 1894.

Editor of THE JEWELERS' CIRCULAR:

It has been reported among the trade that Mr. H. C. Barnum has been obliged to give up his position with us in consequence of the robbery of his trunk at Springfield, Mass., last month. Mr. Barnum has our entire confidence and is out on his trip as usual; and as such a report tends to injure both him and ourselves also, we shall be obliged if you will allow us in this way to correct it.

Yours respectfully,  
SHAFFER & DOUGLAS.

### Last Week's Arrivals.

**THE CIRCULAR has perfected arrangements for obtaining the names and hotel addresses of all the latest buyers visiting New York, and each day posts in its office, 189 Broadway, a bulletin which every member of the trade is cordially invited to copy.**

The following out-of-town dealers were registered in New York during the past week: A. H. Pray, Boston, Mass., Barrett H.; E. Beck, Cincinnati, O., Marlborough H.; E. J. Smith, of Spaulding & Co., Chicago, Ill., Holland H.; M. C. Ellis, Toronto, Ont., Astor H.; A. S. Wright, Portland, Ore., Astor H.; E. H. True, Montrose, Pa., Astor H.; W. H. Wardwell, Boston, Mass., Broadway Central H.; A. Millar, Boston, Mass., Waldorf H.; J. M. Harper, Philadelphia, Pa., Jefferson H.; C. J. Long, Wilkesbarre, Pa., 258 Church St.; J. King, Cleveland, O., Astor H.; E. Oppenheimer, Philadelphia, Pa., Marlborough H. W. H. Zinn, Lafayette, Ind., Imperial H.; H. Koll, Milwaukee, Wis., St. Nicholas H.; M. Brunner, Cleveland, O.; W. R. Goodnow, Boston, Mass., Bartholdi H.; E. Deming, Hartford, Conn., Broadway Central H.; J. M. McCarthy, Syracuse, N. Y., Astor H.; G. T. Howe, Manchester, N. H., Metropolitan H.; W. H. Turner, buyer for Geo. H. Knollenberg Co., Richmond, Ind., St. Stephen H.; Chas. RoCHAT, buyer for Smith & Murray, Springfield, Mass., Park Ave. H.; J. E. Tyler, Richmond, Va., Imperial H.; W. A. Ingraham, Bristol, Conn., Astor H.; S. Tappin, Troy, N. Y., Normandie H.

### THE PHILADELPHIA COLLEGE OF HOROLOGY. A Practical School for Watch-Makers.

Most complete school of horology in America, elaborate outfit of appliances. Skilled and competent instructors. Jewelry work and stone-setting taught, also engraving. Send for prospectus.

F. W. SCHULER & CO.,  
No. 623 HEED BUILDING, PHILADELPHIA, PA.



## News Gleanings.

J. L. Turner, Griffin, Ga., is closing out his stock.

Philo Holderness has opened a repair shop in Batavia, Ill.

B. Jackson has opened a jewelry store in Youngstown, O.

Fred Walker will conduct a jewelry business in Worcester, Mass.

I. M. Dadabaugh will open a repair shop in Madison Lake, Minn.

W. H. Packard has removed from Alexandria, Ind., to Canton, O.

Charles H. Amborn will open a jewelry store in Vicksburg, Miss.

W. H. Grumbine has opened a jewelry business in Southport, Pa.

H. L. Stolz, Bellwood, Pa., has closed out his stock and left town.

L. P. Sandberg will go into the jewelry business in Red Wing, Minn.

The store of Paul Johnson, Cokato, Minn., was damaged by fire last week.

C. R. Sutton, jeweler and watchmaker, has opened a store in Elkland, Pa.

Fred Smith will open a jewelry store in Ehler's block, Binghamton, N. Y.

R. A. Young, Blairsville, Pa., has removed to another location in that town.

C. F. Anderson, Reading, Pa., has returned from a month's business trip to California.

Fire in Gloucester, Mass., caused \$6,000 damage to the business of Calvin Hopkins, some days ago.

Sealed bids for the stock, fixtures, etc., of Holth Bros., Duluth, Minn., were advertised for and opened March 24th.

The business of S. Schrock, Greenwood, Miss., was damaged by fire last week to the extent of \$250; no insurance.

The American Syndicate of Jewelers' Auctioneers are conducting an auction sale for G. A. Bahn, Austin, Tex.

Col. H. A. George, Superior, Wis., has removed his jewelry business from Becker Ave. to the Euclid Hotel block.

R. H. Kline, Spring City, Pa., has sold his jewelry business to his son Frank. The change will take place April 7th.

Jared S. Stiely, Lebanon, Pa., will remove April 1st to 1035 Lehman St., the place he occupied a year or two ago.

As soon as he has disposed of his jewelry stock, W. H. Strohl, Bethlehem, Pa., intends to go into the produce commission business.

Sigmund Hoffman, jeweler, Jefferson, Wis., committed suicide last Wednesday morning by shooting himself with a revolver.

Dingler & Rebert, York, Pa., have purchased the stock and good will of Herman Zeigler, jeweler, Edgmont Ave., Chester, Pa.

D. W. Smith, jeweler, Alliance, O., is one

of a committee to provide provisions for Coxey's commonweal army, and to boom the cause.

Urban J. Kilmer, jeweler, of Womelsdorf, Pa., on Saturday evening wed Miss Mary M. Yost, daughter of George Yost, of Myerstown.

Sheriff McKenzie some days ago sold the jewelry stock of A. E. Castledene, St. Helena, Cal. It was bid in by P. H. Hollihan for \$125.

O. L. Rundell, a graduate of W. F. A. Woodcock's horological school, Winona, Minn., has opened a jewelry store in Spring Valley, Minn.

Sheriff Gallatin, a few days ago, levied on the goods of F. H. Smith, York City, Pa., on an execution for \$75 in favor of Philadelphia parties.

W. E. and John Shoel Collom, sons of Jesse Collom, jeweler, Minneapolis, Minn., have gone to Missoula, Mon., where they will go into business.

George L. Dunkerly, one of the best known watch-case makers in Baltimore, Md., died at 718 N. Broadway, last week, of heart failure. He had been ill some time.

Moskovitz Bros., doing a drug, second-hand clothing and jewelry business in Nashville, Tenn., have assigned to liquidate debts of \$10,400, nearly half of which is held by their mother.

P. Nelson, who has had considerable experience prospecting and mining in western gold fields, claims to have discovered specimens of rubies along the shore of Devil's Lake, N. Dak.

The assets of H. C. Korfhage, Racine, Wis., whose assignment was announced in THE CIRCULAR last week, are placed at \$2,000; liabilities above that amount. L. A. Peil is the assignee.

Beginning with March 17, the factory of T. A. Willson & Co., Reading, Pa., went on six days a week schedule. For five months or more the plant was only in operation five days a week.

J. W. Morrison, a well-known jeweler of West Oakland, Cal., died at his residence recently of typhoid fever. Mr. Morrison was ill only a few days and his death was a surprise to his many friends.

The Illinois Watch Case Co.'s factory, Elgin, Ill., has been running 48 hours per week. Commencing last Monday about one-fourth of the force will be employed 10 hours per day, six days per week.

It is reported that Geo. McCormick, of Knoxville, Tenn., has just found on his farm near Abingdon, Va., nearly 200 Mexican opals ranging in value from \$5 to \$100. The stones were found at the foot of an old tree in a secluded spot.

James Blake and Charles Wicklow, charged with robbing the jewelry store of M. Huck, North Bend, Neb., with others escaped from the Dodge County jail during the night of March 18. They sawed off several of the iron bars of their cell.

The firm of Cooper, Freed & Crockin, formerly Freed & Crockin, Baltimore, Md., have been dissolved by mutual consent, Victor Freed having retired. The remaining partners, under the firm name of Cooper & Crockin, will continue the manufacture of solid gold rings, as formerly. The item, as last week published, was erroneous.

The American Optical Co.'s works, Southbridge, Mass., have been running since last Fall on short time with a few hands. The works started March 19 on a time schedule of ten hours a day and six days a week. About 60 hands went to work and in two or three weeks, or as soon as the company receives several large orders which they are expecting, the rest of the old help will be given work.

James E. Swartout's residence in Elmira, N. Y., was entered by three daring burglars last Sunday night. Mr. Swartout and family had been in New York for the previous week. During their absence their home was unoccupied. The burglars succeeded in getting out of the house in spite of the presence of officers, and a long chase followed. Joseph Curry was captured, and articles of jewelry were found in his possession; Joseph Haycock was also later arrested and an entire burglar's outfit was revealed. The third burglar is at large. Mr. Swartout is a well-known jeweler of Elmira.

## Wilmington, Del.

H. Hoegelsberger, oculist and optician, whose office is at 816 Market St., will add a complete line of watches, clocks and jewelry to his stock of optical goods.

The show window of the Gem Jewelry Store was broken into Friday morning, about 2 o'clock, and \$150 worth of jewelry was stolen. Detectives are at work on the case.

The modest jewelry store opened by Wm. S. Phillips, of Philadelphia, about a year ago has outgrown its quarters on Shiply St. and now he is nicely located in a pretty little shop at 706 King St. with a well chosen stock.

## Syracuse, N. Y.

Bert M. Polley, Norwood, was in the city buying goods last week.

E. C. Meacham, with H. J. Howe, has been visiting his old home in Livonia for a week.

E. C. Eager has recently put in a self-winding clock, synchronized to time daily by the Western Union system.

Simon Lesser, of A. Lesser's Sons, returned on Friday from a four weeks' trip through Pennsylvania, and left Sunday night for a short business trip to New York.

Henry C. Barnum, of Shafer & Douglas, New York, is again on the road as usual, and will call on his friends as in days past. His suspension for a short time does not affect his work or standing with his house and customers.



# CLASSIFIED INDEX TO ADVERTISEMENTS.

All Advertisements are entitled to one insertion under proper heading. Extra insertions, \$6.00 per annum. Extra Headings, \$12.00 per annum.

	Page.		Page.		Page.
<b>Art Pottery, Bric-a-brac, Etc.</b>		<b>Hotels.</b>		<b>Silver Mounted Ebony Goods.</b>	
Ahrenfeldt, Charles & Son, 50-52-54 Murray St., N. Y.....	38	Gibson House, Cincinnati, O.....	22	Deitsch Bros., 7 E. 17th St., N. Y.....	2
Bing, Ferdinand & Co., 106 Grand St., N. Y..	38	<b>Jewelers' Findings.</b>		<b>Silver Plated Ware.</b>	
Borgfeldt, Geo. & Co., 18, 20 & 22 Washington Place, New York.....	41	Lind, Thos. W., Providence, R. I.....	25	Pairpoint Mfg. Co., New Bedford, Mass.....	5
Haviland & Abbot, 29 Barclay St., N. Y.....	43	<b>Jewelry Mailing Boxes.</b>		<b>Sterling Silver Novelties.</b>	
Healey, M. & E., Washington, D. C.....	38	Am. Railway Supply Co., 24 Park Place, N. Y.	44	Codding Bros. & Heilborn, North Attleboro Mass.....	42
Hinrichs & Co., 29 & 31 Park Place, N. Y....	43	<b>Jewelry, Silverware and Optical Cases.</b>		<b>Sterling Silverware.</b>	
Straus, L. & Sons, 42 to 48 Warren St., N. Y.	37	Jackson, S. C., 180 Broadway, N. Y.....	38	Alvin Mfg. Co., 860 Broadway, N. Y.....	17
Vantine, A. A. & Co., 877-79 Broadway, N. Y..	40	Steinhaus, Theo. C., 10 Maiden Lane, N. Y...	26	Campbell-Metcalf Silver Co., Providence, R. I.	2
<b>Assayers &amp; Refiners.</b>		<b>Jobbers, Watches, Diamonds, Etc.</b>		Durgin, Wm. B., Concord, N. H.....	9
Clark, J. L., Philadelphia, Pa.....	37	Allen, Benj. & Co., Chicago, Ill.....	19	Knowles, J. B. & S. M. Co., Silversmiths' Hall, Union Square, N. Y.....	7
Howard, S. P., 33 Maiden Lane, N. Y.....	44	Bell, O. E. & Co., Cincinnati, O.....	22	Niagara Silver Co., 454 Main St., Niagara Falls, N. Y.....	16
Schawel, J. & Co., 29 John St., N. Y.....	44	Brethauer Watch and Jewelry Co., Chicago, Ill.	20	Reed & Barton, 37 Union Square, N. Y.....	20
<b>Auctioneers.</b>		Cross & Beguelin, 17 Maiden Lane, N. Y.....	2	Shiebler, Geo. W., Co., 179 Broadway, N. Y...	4
American Syndicate of Jewelers' Auctioneers, New York and Washington.....	2	Freund, Max & Co., 8 Maiden Lane, N. Y....	37	Towle Mfg. Co., Newburyport, Mass.....	43
Comrie, A. J., 182 Broadway, N. Y.....	42	Myers, S. F. & Co., 48 Maiden Lane, N. Y....	44	Wallace, R. & Sons Mfg. Co., 3 Park Place,	6
Prince, J., 137 Broadway, N. Y.....	44	Oppenheimer Bros. & Veith, 35 Maiden Lane, N. Y.....	26	Whiting, F. M. & Co., North Attleboro, Mass.	8
Scott, De B. O., 20 Murray St., N. Y.....	43	<b>Leather and Silver Goods.</b>		Wood & Hughes, 16 John St., N. Y.....	37
<b>Badges, Medals, Etc.</b>		Deitsch Bros., 7 E. 17th St., N. Y.....	2	<b>Spectacle and Eyeglass Cases.</b>	
Irons & Russell, Providence, R. I.....	37	<b>Musical Boxes.</b>		Birmingham, Wm. & Co., 728 Arch St., Phila..	44
Richardson, J. W., 200 Broadway, N. Y.....	8	Jacot & Son, 298 Broadway, N. Y.....	2	White, W. B. & Son, Boston, Mass.....	4
Stockwell, E. R., 19 John St. N. Y.....	17	<b>Office Furniture.</b>		<b>Stem Winding Attachments.</b>	
Willson, Chas. G., Reading, Pa.....	42	Schwartzwelder & Co., New York.....	17	Abbott, Henry, 2 Maiden Lane, N. Y.....	8
<b>Clocks, French, English and American.</b>		<b>Optical Goods.</b>		<b>Tortoise Shell Goods.</b>	
Jacques, Chas., Clock Co., 22 Cortlandt St., N. Y.....	44	Berger, Albert & Co., 47 Maiden Lane, N. Y..	44	Potter, W. K., Providence, R. I.....	43
<b>Diamond &amp; Precious Stone Importers.</b>		Kirstein's, H. E., Sons Co., Rochester, N. Y..	37	<b>Tool Manufacturers and Dealers.</b>	
Disselkoe, John N., 19 E. 16th St., N. Y.	27	McIntire & Ulmer, cor. 8th and Sansom Sts., Philadelphia, Pa.....	11	American Watch Tool Co., Waltham, Mass..	37
Falkenau, Oppenheimer & Co., 40 Maiden Lane, N. Y.....	44	Queen & Co., Philadelphia, Pa.....	11	Bullock, O. W. & Co., Springfield, Mass.....	4
Hedges, Wm. S. & Co., 170 Broadway, N. Y....	26	Spencer Optical Mfg. Co., 15 Maiden Lane, N. Y.	42	Hardinge Bros., Chicago, Ill.....	20
Kipling, R. A., Hays Bldg., N. Y.....	26	<b>Paneled Metal.</b>		Logan, A. J., Waltham, Mass.....	5
Randel, Baremore & Billings, 29 Maiden Lane	27	Northrop, A. & Co., Pittsburgh, Pa.....	43	Moseley & Co., Elgin, Ill.....	21
Smith, Alfred H. & Co., 182 Broadway, N. Y..	26	<b>Paper Boxes.</b>		Oliver, W. W., Buffalo, N. Y.....	21
Tannenbaum, L., & Co., cor. Maiden Lane and Nassau St., N. Y.....	15	Warner Bros., Bridgeport, Conn.....	38	Waltham Watch Tool Co.....	7
<b>Fine Stationery.</b>		<b>Pens, Pencil Cases, Etc.</b>		<b>Trunks and Traveling Bags.</b>	
Parsons & Greene Co., 18 Murray St., N. Y....	5	The Boston Pen Co., Boston, Mass.....	37	Crouch & Fitzgerald, 161 Broadway, N. Y....	5
<b>Gold and Silver Plating Works.</b>		<b>Patents.</b>		<b>Watch Manufacturers.</b>	
Bolstad Mfg. & Plating Co., Chicago, Ill.....	24	Belt, C. T., Washington, D. C.....	5	Charmilles Watch.....	25
<b>Gold and Rolled Plate Jewelry.</b>		<b>Photo-Miniatures.</b>		<b>Watch Case Manufacturers.</b>	
Foster & Bailey, Providence, R. I.....	3	Favre, Leon, 107 E. 26th St., N. Y. City.....	7	American Watch Case Co., Corbin Building, New York.....	44
Read, M. L. & Co., Providence, R. I.....	4	<b>Platinum Importers.</b>		Roy Watch Case Co., 21 Maiden Lane, N. Y.....	7, 8, 10
<b>Gold Jewelry.</b>		Schawel, J. & Co., 29 John St., N. Y.....	44	Wadsworth Watch Case Co., Newport, Ky. ...	23
Carter, Sloan & Co., 15 Maiden Lane, N. Y..	27	<b>Ring Makers.</b>		<b>Watch Case Repairers.</b>	
Johnson, R. M., 67 Washington St., Chicago, Ill.	20	Bryant, M. B. & Co., 10 Maiden Lane, N. Y..	37	The Planchamp & Becker Co., Chicago, Ill. ...	20
Kremenz & Co., 182 Broadway, N. Y.....	2	Bowden, J. B. & Co., 192 Broadway, N. Y....	7	<b>Watchman's Clocks.</b>	
Pfeil, Chas. H., Chicago, Ill.....	21	Hildreth Mfg. Co., 53 Maiden Lane, N. Y....	38	Hausburg, O. E., 41 Maiden Lane, N. Y.....	44
Unger Bros., 192 Broadway, N. Y.....	12	<b>Rubber Stamps and Type.</b>		<b>Watch Importers.</b>	
Webster, G. A., Chicago, Ill.....	8	Dietz, Wm. H., Chicago, Ill.....	22	Hyde's, J. E., Sons, 22 Maiden Lane, N. Y..	5
<b>Gold and Silver Novelties.</b>		<b>Sample Trunks.</b>		Mathey Bros., Mathez & Co., 21 & 23 Maiden Lane, N. Y.....	4
Battin & Co., Third Ave. and Ogden St., Newark, N. J.....	15	Crouch & Fitzgerald, 161 Broadway, N. ....Y	5	Robert, Edmond E., 21 Maiden Lane, N. Y....	44
<b>Horological Schools.</b>		<b>Show Cases.</b>		<b>Watch Keys.</b>	
American Horological Institute, Lancaster, Pa.	22	Smith, B. & W. B., 220 W. 29th St., N. Y....	44	Clark, A. N., Plainville, Conn.....	2
Chicago Watchmakers' Institute, Chicago, Ill.	20				
Elgin Horological School, Elgin, Ill.....	21				
Parson's School for Watchmakers, Peoria, Ill.	21				
Philadelphia College of Horology, 623 Heed Building, Phila., Pa.....	30				



## Special Notices.

Rates 75c. per insertion for notices not exceeding 5 lines (25 words); additional words 2 cents each. If answers are to be forwarded, postage stamps must be enclosed. Two insertions, 15 per cent. off; three insertions, 20 per cent. off; four insertions or more, 25 per cent. off. Payable strictly in advance. Display cards on this page will be charged at \$2.00 per inch for first insertion, subject to same discount as above for subsequent insertions.

Under the heading of **Situations Wanted** on this page advertisements will be inserted for **One Cent a Word**. This offer refers to **Situations Wanted only**. Payable strictly in advance. If answers are to be forwarded, postage must be enclosed.

## Situations Wanted.

Notices under this heading **ONLY** are charged at one cent a word, payable strictly in advance. If answer are to be forwarded, postage must be enclosed.

**WANTED, SITUATION**—Manager of a business for two years past. Do all branches of work—watchmaking, engraving, seal making, jobbing, selling, buying. Box 695, What Cheer, Ia.

**SITUATION WANTED** as watch and clock maker; also jewelry repairer; age 21; speaks English and German; good references. Address A. Guenther, 875 Sixth Ave., New York.

**WANTED**—Position by a young man aged 22 years. Can do clock, watch and jewelry repairing. Best of references. Address C. W. P., 413 S. Main St., Waterbury, Conn.

**SALESMAN** with a large personal acquaintance with retail jewelry trade in Buffalo and vicinity wishes to represent a few manufacturers on commission. Address Reference, care THE JEWELERS' CIRCULAR.

**SITUATION WANTED** by an **AT** watchmaker, jewelry jobber and engraver. Can repair repeaters, chronographs and all other fine watches; 16 year at the bench; good salesman; sober and reliable; good set of tools; **A1** references. Address P. B. L., P. O. Box 412, Winchester, Ill.

**SITUATION WANTED** by a thorough watchmaker and jeweler after April 1st; good letter engraver; owns tools; best references. Lock Box 595, Pensacola, Florida.

**WANTED** position in Central States by watchmaker, clock and jewelry repairer, engraver and good salesman; a thorough general workman; single and sober. Address M. M. G., care of THE JEWELERS' CIRCULAR.

**SITUATION WANTED** by first-class jeweler and watchmaker, 10 years' experience; owns tools; open for engagement April 15th. Address B. P., care of THE JEWELERS' CIRCULAR.

**POSITION WANTED** by a young man, with three years' experience in watch, clock and jewelry work. Reasonable wages. Good references. Address P. O. Box 248, Reedsburg, Wis.

**SITUATION WANTED** by a boy, having three years' experience in the silver and jewelry business. Address Advance, care THE JEWELERS' CIRCULAR.

**YOUNG MAN** wishes position as second watchmaker. Can do ordinary watch, clock and jewelry repairing. Has tools and is competent. Address R. B., care of THE JEWELERS' CIRCULAR.

**SITUATION WANTED** by a young man who has had three years' experience at watch, clock and jewelry repairing. First class references. Address P. O. Box 249, Castleton, N. Y.

**WE HAVE IN OUR EMPLOY** a young man of excellent habits and one whom we can recommend as a good watchmaker and engraver. We would like to find him a good position. For further particulars address Hoffman & Robinson, Lyons, N. Y.

**POSITION WANTED** in a retail jewelry store as salesman or at the bench. Five years' experience. Address F., care of THE JEWELERS' CIRCULAR.

**YOUNG MAN** wants position where he can learn the jewelers' trade. Good engraver; have samples. Good references, and industrious. Address Engraver, care of THE JEWELERS' CIRCULAR.

**SITUATION WANTED** by an expert English watchmaker of 17 years' experience. Good diamond moulder and plain engraver. **A1** references. Willing to do jewelry work. Own tools. Address Expert, Box 134, San Marcial, New Mexico.

**POSITION WANTED** as traveling salesman with a silver plate, sterling or jewelry house; 12 years on road with silver plate; extensive acquaintance with trade; references. Address L. R. N., care of THE JEWELERS' CIRCULAR.

**SITUATION WANTED** as engraver and watchmaker with good house; have lathe, bench, tools, etc.; do all kinds of watchwork and engraving; pierced monograms and dies for stationery. Address Rasco, care of THE JEWELERS' CIRCULAR.

**ENGRAVER, AT**. Lettering in all its branches. Monograms, ciphers and ornamental work. Also capable of doing copper plate and die cutting for stationery trade. Open for engagement after May 1st. Address J. J. M., care THE JEWELERS' CIRCULAR.

**A COMPETENT WATCHMAKER** would like a position; 18 years' experience on fine and complicated work; perfect set of tools. Address Curtis, care of THE JEWELERS' CIRCULAR.

**POSITION WANTED** by first class watchmaker having 10 years' experience; owns fine set of tools. Address Staff, care of THE JEWELERS' CIRCULAR.

**WORK WANTED FOR JEWELERS, SILVERSMITHS, ENGRAVERS, DESIGNERS, WATCHMAKERS, CASEMAKERS, TOOLMAKERS, ETC. ONLY WORKMEN WITH GOOD TESTIMONIALS FROM PREVIOUS EMPLOYERS ARE RECOMMENDED.**  
ADDRESS,  
**JEWELERS' RELIEF ASSOCIATION,**  
11 MAIDEN LANE, N. Y.

## Help Wanted.

**WANTED.**—A first-class watchmaker, who has lathe and tools; must be experienced and first-class in every way. Will pay good price to the right man. Ryan, Barrows & Parker, Middletown, Conn.

**A YOUNG, RELIABLE MAN** to dress jewelry windows and to act as salesman when not occupied in window dressing. References required. Davidow Bros., 217 Lackawanna Ave., Scranton, Pa.

**YOUNG MEN** desiring to learn watchmaking thoroughly, or to finish their trade, address for terms, A. Naundorf, 120 S. 7th St., Philadelphia, Pa.

## To Let

**TO LET.**—A large office, 20 x 40, first floor, No. 11 Maiden Lane. \$60 a month.

**FOR RENT** in Corbin building, 11 John St., sixth floor, half of an office with or without large safe convenient for jeweler. For further particulars, address the janitor of the building.

**BROADWAY STORE** near the Post Office; desirable location; moderate rent; lease. Apply on premises, 2 Astor House.

**CORNER STORE TO RENT,** 21 1/2 x 85, No. 20 Maiden Lane. Possession May 1st. Terms reasonable. Inquire Room 9, above store.

## Miscellaneous.

**I BUY JEWELRY STOCKS**—Manufacturers, jobbers and retailers desiring to dispose of surplus or entire stocks of diamonds, watches and jewelry can find quick cash buyer by addressing Stephen S. Harmon 134 East 96th St., New York City.

**RICH** cut glass to exchange for rings, diamonds, watches, china and silver ware. Brighton Glass Cutting Co., New Brighton, Pa.

**STOLEN**—A gold watch, 14 karat case. Marked inside E. T. E. B. E. C. No. 634,923. E. Howard & Co. movement, No. 229,614. The watch needed repairs; make note of numbers so as to stop it if offered. A suitable reward for its recovery. Address B, P. O. Box 284, Hartford, Conn.

## DEMAGNETIZING.

**PERFECT WORK**—Watch repairing in all its branches; all work warranted. Winslow & Penney, 608 Masonic Temple, Chicago.

**FOURTEEN** karat gold solder that will flow on eight karat work; makes a hard solder job a pleasure. With this solder there is no danger of melting low karat specs. No white joints on rings. It is just what you want. Sample by mail 25 cents. F. W. Hall, Sterling Silver Novelties, Columbus Memorial Building, Chicago, Ill.

**WANTED TO PURCHASE.**—Good paying jewelry store for cash in New York or Brooklyn. Address L. B., care THE JEWELERS' CIRCULAR.

## For Sale.

**FOR SALE**—A first-class optical store, stock and fixtures, in a city of over 100,000 inhabitants in New York State. Best location in city; for full particulars address **At Chance**, care of THE JEWELERS' CIRCULAR.

**FOR SALE.**—A first-class jewelry store in a city of 10,000 inhabitants, southern Pennsylvania; large, roomy store with two plate glass front and side show windows, 5x5 by 10 feet high; a nice clean stock, fixtures almost new. Will invoice \$5,000; can be reduced to \$3,500; over three fourths of stock consists of staple goods; good run of bench work; must be sold at once; a good discount allowed to cash purchaser. For full particulars address **Good Chance**, care THE JEWELERS' CIRCULAR.

**ASSIGNEE'S SALE** of jewelry, stock, watches, silverware, jewelry show cases, safe, tools, engraving machine, etc. Must be sold. Address E. O. Dilley, assignee, Warren, Ohio.

**FOR SALE.**—An old established jobbing house in New York City, having a good established trade and an extended valuable reputation. A free investigation invited. Terms strictly cash. Address Jewelry, care of THE JEWELERS' CIRCULAR.

**FOR SALE.**—The leading jewelry business in one of the best railroad towns, of 3,000 inhabitants, in northern Illinois. Only one other store. Address S, care of THE JEWELERS' CIRCULAR.

**\$5,000** for long established retail Jewelry business in city of 100,000 inhabitants;

**YEARLY PROFIT ABOVE EXPENSE, \$3,500.** Can be greatly increased by additional capital if desired.

Satisfactory reasons for selling given to parties with necessary cash capital. Address, **CHANGE**, care of THE JEWELERS' CIRCULAR.

## SAFES FOR SALE.

(CHOICE OF TWO.)

Will sell at one fifth the original cost; size, 56x38 inside measurement. Apply to or address,

**OPPORTUNITY,**

Care THE JEWELERS' CIRCULAR.

## FOR SALE.

The Old Established Jewelry Business of G. A. SCHULTZ (Dec'd), is for sale at a great bargain. New fixtures throughout; good location. Address

**HELENA SCHULTZ, Ex'trix,**  
Corner 7th & Market Streets, LOUISVILLE, KY.

## TO LET! PART OF STORE.

**Chas. Jacques Clock Co.**  
22 CORTLANDT STREET, NEW YORK.

**SPECIAL NOTICES**  
IN  
**THE JEWELERS' CIRCULAR**  
Produce the results desired.



**The Latest Patents.**

ISSUE OF MARCH 20, 1894.

**516,683. COLLAR-BUTTON.** BENJAMIN HURST and LEOPOLD ROSENBERG, St. Louis, Mo.—Filed June 17, 1893. Serial No. 477,929. (No model.)

In a collar button, the combination with the button head or stud which is adapted to be secured in the

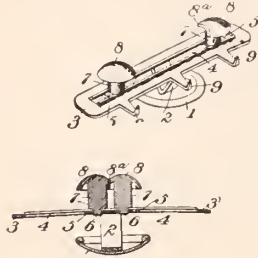

button-hole in the neck-band of a shirt, of a bar secured thereto, collar-button heads which are slidingly mounted on the bar, and means for adjusting said button heads toward and from each other.

**516,718. WATCH.** SAUL ARONSON, Brooklyn, assignor to the Star Watch Company, New York, N. Y.—Filed Sept. 21, 1892. Serial No. 446,492. (No model.)

The herein-described improvement in watches, consisting of the combination in a watch movement, and a case therefor having a slot, of a barrel having teeth, a spur gear in engagement with said teeth, a stem for

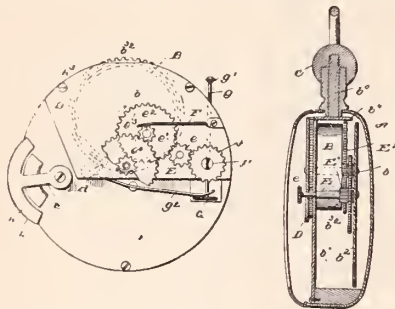

said spur gear, a regulator having a toothed segment projecting into said slot, the loose wheel *e*, the dial wheel in engagement therewith, the pinion carried by said dial wheel, the minute and hour pinions and wheel, the wheel *f*, and the sliding rod carrying a wheel designed to engage said wheel *f*.

**516,779. POLISHING AND FILING ATTACHMENT FOR LATHES.** CHARLES TESKE, Springfield, Mass.—Filed June 16, 1893. Serial No. 477,805. (No model.)

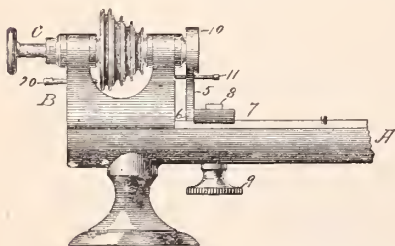

The herein described polishing attachment consist ing of the standard adapted to be clamped to the lathe bed, the guide 10 at the upper end of said standard and the adjusting set screw 11 arranged within said standard for projecting its end against the end of the head block.

**516,998. WATCH-CARRIER FOR BICYCLES.** GEORGE K. BURLEIGH, Tilton, N. H.— Filed Aug. 8, 1893. Serial No. 482,667. (No model.)

A watch-carrier for bicycles, it consisting of a piece of wire bent to form separable and double spring arms or jaws to receive a watch case between them and pinch

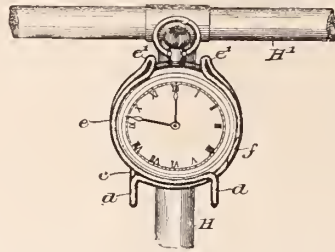

the case thereof in the direction of its thickness, and a device to which the ends of said wire are rigidly secured, said device being adapted to serve as a connection between the carrier and the bicycle.

**DESIGN 23,119. SPOON.** WALLACE DURAND, Newark, N. J.—Filed Nov. 24, 1893. Serial No.



491,887. Term of patent 7 years.

**DESIGN 23,120. SPOON.** WALLACE DURAND, Newark, N. J.—Filed Nov. 24, 1893. Serial No



491,888. Term of patent 7 years.

**DESIGN 23,121. SPOON.** WALLACE DURAND, Newark, N. J.—Filed Nov. 24, 1893. Serial No.



491,889. Term of patent 7 years.

**DESIGN 23,122. SPOON.** WALLACE DURAND, Newark, N. J.—Filed Nov. 24, 1893. Serial No.



491,890. Term of patent 7 years.

**DESIGN 23,123. SPOON.** WALLACE DURAND, Newark, N. J.—Filed Nov. 24, 1893. Serial No.



491,891. Term of patent 7 years.

**DESIGN 23,124. SPOON.** WALLACE DURAND, Newark, N. J.—Filed Nov. 24, 1893. Serial No.



491,892. Term of patent 7 years.

**DESIGN 23,125. SPOON.** WALLACE DURAND,

Newark, N. J.—Filed Nov. 24, 1893. Serial No.

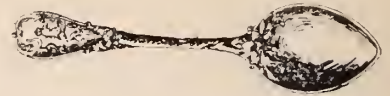

491,893. Term of patent 7 years.

**DESIGN 23,126. SPOON.** WALLACE DURAND, Newark, N. J.—Filed Nov. 24, 1893. Serial No.



491,894. Term of patent 7 years.

**DESIGN 23,127. SPOON.** WALLACE DURAND, Newark, N. J.—Filed Nov. 24, 1893. Serial No.



491,895. Term of patent 7 years.

**DESIGN 23,128. SPOON.** WALLACE DURAND, Newark, N. J.—Filed Nov. 24, 1893. Serial No.



491,896. Term of patent 7 years.

**DESIGN 23,129. SPOON.** WALLACE DURAND, Newark, N. J.—Filed Nov. 24, 1893. Serial No.



491,897. Term of patent 7 years.

**DESIGN 23,130. SPOON.** WALLACE DURAND, Newark, N. J.—Filed Nov. 24, 1893. Serial No.



491,898. Term of patent 7 years.

**DESIGN 23,145. METALLIC BORDER.** CHARLES C. WIENTGE, Providence, R. I., assignor to the

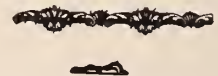

Howard Sterling Co., same place. Filed Feb. 23, 1894. Serial No. 501,313. Term of patent 7 years.

**Expired Patents.**

EXPIRED MARCH 20, 1894; GRANTED MARCH 20, 1877.

**188,623. TIME-LOCKS.** LEWIS A. HAINES, Westminster, Md., assignor, by mesne assignment, of one half his right to the Taylor Mfg. Co., same place.—Filed Feb. 26, 1876.



# MATTERS IN JEWELRY STOREKEEPING.

That this department shall prove mutually beneficial to our readers, it is desirable that the members of the trade generally communicate with THE CIRCULAR regarding any advantageous device or plan they are utilizing in the conduction of their business.

## Advertising Thermometer for Opticians.

THE illustration represents a show thermometer, manufactured by Queen & Co., Philadelphia, Pa. A large spectacle is outlined over the scale, in such a way that there is no loss in distinctness in the reading. The length of the thermometer is four feet; the width ten inches.

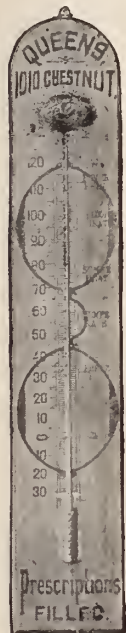

Show thermometers when properly put up, are a permanent advertisement, and but little difficulty is experienced in obtaining excellent locations for them. It is advisable to have an employe put the thermometer into position, rather than the owner of the premises, as breakage and loss of the instrument will be avoided. The thermometer should be put up securely, so that it cannot be either blown or knocked down.

### Not a Bad "Ad" Scheme.

THE following, quoted from a Sioux City, Ia., paper, is not a bad "ad" scheme:

#### SHE CAUGHT ON.

HOW AN UP TO DATE YOUNG WIFE KEPT TAB ON HER HUSBAND.

They had been married about a year, but it was a love match and didn't grow old. He lived in an outside town, but made frequent business trips to Sioux City. On one of his periodical visits he thought to furnish his wife with an agreeable surprise, and went to a leading jewelry establishment and bought a magnificent ladies' gold watch with reliable movement, and left it in the manufacturing department to have it engraved in time for her birthday. In the meantime his wife came down to visit her Sioux City lady friends, and in taking in the sights they were shown through the aforesaid manufacturing department, and were much pleased to see gold melted into bricks and the various processes of engraving. One of the workmen was engaged in lettering a beautiful ladies' watch with a monogram that looked strangely familiar to the wife. She smelled a mouse, but kept quiet and loved her husband harder every day until her birthday came, when she received fresh

from Hattenbach Bros. her watch beautifully engraved.

Husbands who want to renew the courting season would do well to consider.

### Forced Some One to Buy the Set.

A. R. JUSTICE & CO., Philadelphia, Pa., struck upon a unique and interesting advertising device a few days ago. They placed in one of their show windows a solid silver tea service, and announced its price for the first day as \$75. Each day thereafter \$5 was to be cut from the price till someone purchased the set. If no offer was made till the last \$5 was cut off, then the articles were to be given to the first person who asked for them.

The silverware and the unique scheme attracted a deal of attention, and as each day the \$5 was duly marked off, many a passer-by wondered who would be the one fortunate enough to get it for nothing. The suspense was ended when the price had fallen to \$30. A man walked in and bought it, and, it is said, he got a great bargain.

### An Easter Window That Proved a Great Attraction.

BROOKLYN, N. Y., March 24.—The Easter window of Wm. Wise & Son attracted unusual attention this week. People stood four and five deep patiently waiting their turn to get a glimpse of the picturesque miniature scene of a stream dashing down the mountain side in a winding course and leaping over the rocky bed strewn with diamonds, and finally emptying itself into a beautiful lake where the gold fish and the polywog sported. In the center of the lake was a rock on which rested unmounted brilliants and a lizard set with emeralds and diamonds. Around the edge of the lake were seen brooches, stick pins, etc., in the shape of frogs, turtles, grasshoppers, lizards, crabs and other animals that haunt the banks of such streams in nature.

Floating on the surface of the lake were natural tulips, daisies and beautiful green leaves with diamonds nestling on them to represent dew drops, while the pebbly bottom was strewn with sparkling brilliants. After filling the lake to the brim, the water rushed through a small stream filled with brilliants, and disappeared behind a mossy bank. Over the banks of the stream was enameled jewelry mounted with diamonds in the form of roses, violets, orchids, daisies, lilies, pansies, sweet peas, chrysanthemums, mistletoe, etc., and among these were placed

the natural flowers with diamonds arranged in their petals in an ingenious and original manner.

Particularly beautiful was the effect produced by setting diamonds in the centre of the pansies and hyacinths. Brooches in the form of birds and butterflies were perched in the trees and apparently flitted among the flowers. Diamond ear-rings hung from the bushes to represent dew drops while diamonds nestled in the moss in all directions. A magnificent diamond brooch played the part of the setting sun. For a background beautiful azaleas, hydrangeas and Easter lilies were utilized. The window for novelty and attractiveness, has perhaps, not been equaled. The designers were J. F. Fogerty and M. S. Poulson.

### A Girl's Experience with Her Watch.

A GIRL of Wilkesbarre, Pa., has recently had a remarkable experience regarding the loss of a watch, wherein the honesty of a New York gentleman is worthy of remark. The young lady in question was returning from a visit in New England and when about to take the train in New York she missed her watch. But the train was in motion and she could do nothing but mourn for a beautiful timepiece. She, of course, was firmly convinced that the watch had been stolen from her. She soon went away on another visit, without having mentioned to her parents the fact of her loss.

Not long after she had gone her mother received a letter from a Boston jeweler, asking if her daughter's watch had been lost—if so, to communicate with him. The mother wrote her daughter asking if she had lost her watch and telling her to write to the jeweler. The daughter wrote home, "How did you know I had lost my watch?" and to the jeweler she wrote, "Yes, the watch is mine." She described it and ordered it sent to her.

### Points of Law.

#### SETTLEMENT OF PARTNERSHIP.

A partner who has knowledge of entries in the partnership books by his co-partner, charging him with items for which he is not liable, is guilty of neglect in settling up the partnership business, on the showing made by the books, without examining them to see if they have been corrected to conform to his contention, and he cannot thereafter impeach the settlement on the ground that the books were not correct.

*Kneeland v. McLachlan, Court of Civil Appeals of Texas.*

#### DAMAGES FOR CONVERSION.

Where a chattel mortgagee takes possession of the mortgaged property and, after using it for several months, sells it without notice to the mortgagors, the latter, in an action on the notes, can plead the damages for the conversion in reconvention.

*Streeper v. Thompson, Court of Civil Appeals of Texas.*



### A Modernized Water Clock.

THE *Almanac des Horlogers* contains the accompanying cut and description of an attractive little apparatus, and advises lovers of ingenious mechanisms to make one. By the way, it would be a most attractive window ornament for a watchmaker. In these "piping" times of unerring precision of rate of a time-piece, no one will naturally expect that a mechanism of this kind should go unflatteringly and absolutely correct; in fact as long as it is treated in conformity

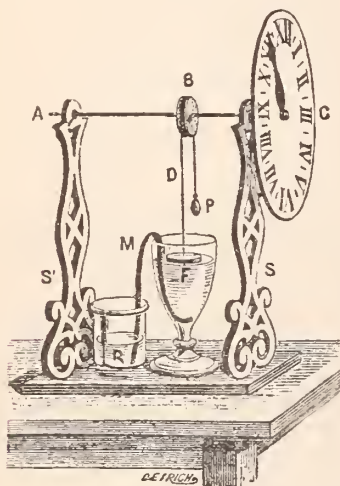

WATER-CLOCK.

with the advice of Captain Cuttle, when he presented his watch to his son, viz: to wind it once a day, and move the hands forward about fifteen minutes every morning, and likewise fifteen minutes at night, "and you'll have a watch on which you can rely," the watchmaker will have a window show-piece calculated to attract the gaze of the passer-by. The description is about as follows: A thin arbor A nests upon two supports S S<sup>1</sup> (a straight and truly round knitting needle will answer the purpose well); one of its ends protrudes beyond the dial fastened at S<sup>1</sup>, and carries a hand. The hours only are marked upon the dial, and, consequently this the only hand is the hour hand.

About in the middle of the arbor A is fixed a pulley B with a deep groove. Around this pulley is wrapped a thread, one end of which carries a cork float F, while a small center-weight is attached to the other end.

## ONE YEAR'S SUBSCRIPTION

—TO—

The  Jewelers'  Circular

—At \$2.50,—

Entitles the subscriber to a copy of "WORKSHOP NOTES" free, a 200 page book, bound in cloth, containing a fund of information for the workshop that can be found in no other work.

Exactly underneath the float F is a so-called "tulip" glass which is filled with water to the rim when the clock is started. A conduit, an ordinary cotton wick M, passes into an empty cylindrical vessel R, which stands close by.

The natural consequence ensues. The wick M acts to a certain degree as a syphon, absorbing the water in the glass E and discharging it into the lower vessel R; in consequence of this the former empties slowly, while the latter fills gradually. The sinking of the water level naturally produces the same with the float F, thereby actuating the pulley B, the arbor A, and the hour hand C. By a suitably large pulley B, the hour hand can be made to revolve in an approximately correct time.

The somewhat conical (cylindro-conical) shape of the glass F is for the present purpose calculated by a Professor Pellet, of Paris, and serves for making the motion of the hour hand as steady as that of a water apostle. The water ascends in the wick slower than it descends; this more rapid motion takes place as soon as the water has passed over the culminating point, the rim of the glass E. Since, now, the water level in E is sinking constantly, the ascent which the water in the wick has to make up to the rim of E, becomes larger constantly, and, therefore, the hand would gradually move slower if the diameter of the glass E were uniform down to the bottom. For this reason, its shape must be tapering, so that an increasingly smaller quantity of the water arising in the wick suffices to let the float F sink uniformly.

By experiments and calculating their results, the quantity of the taper necessary for the glass to have can be established precisely; but THE CIRCULAR thinks that even after having the necessary data, it is questionable whether such a precisely shaped glass can be procured. There are a number of other considerations too lengthy for THE CIRCULAR to count up; still, in spite of them one or the other of its readers may be tempted to construct a clepsydra of this kind, and label it "An imitation of an antique Roman water clock."

### Vise-stake.

THE little stake shown in accompanying illustration and described below is the invention of a watchmaker in Germany and patented in that country. As its general features are similar to a vise, although its principal purpose is to serve as a stake, the inventor has called it vise-stake. It consists of a brass foot *c*, which is at its further end furnished with a shoulder. To this are fastened on both sides two steel jaws *aa*<sup>1</sup> by means of screws in such a manner that their lower ends stand firmly upon the foot *c*. In consequence of this the two jaws *aa*<sup>1</sup> are capable of resisting a proportionately large pressure if exerted in a direction of length.

The two jaws *aa*<sup>1</sup> are made weaker near

their lower ends so that they will spring apart, although they can be screwed together firmly by a screw *f*; their upper faces are furnished with notches *d d*<sup>1</sup> at right angles to each other for accommodating a balance staff, wheel arbor, etc. The abutting ends of the faces *dd*<sup>1</sup> are sharpened to permit them to hold the article tightly. The illustration of the little tool suggests its purpose so plainly that no elaborate description is necessary by THE CIRCULAR.

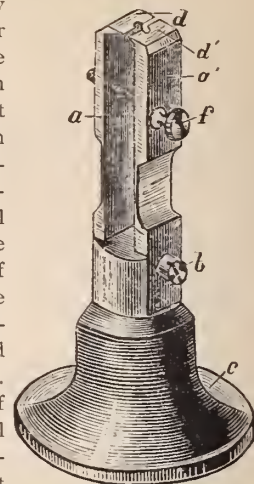

### Workshop Notes.

**Gold Tinge to Silver.**—A bright gold tinge may be given to silver by steeping it for a suitable length of time in a weak solution of sulphuric acid and water, strongly impregnated with iron rust.

**Bent Pivots.**—If a pivot is bent, place in pliers and blow the flame from your lamp on to the pliers until the temper is drawn from the pivot; then press them together, and the pivot will be straightened in two or three trials.

**Displaced Barrel.**—Remove the arbor from the barrel. Turn a washer of brass or steel the same size as the arbor. Put it—the washer—on the inside of the barrel on the arbor below where the mainspring winds.

**Safety Pinion.**—The safety pinion, if working on a screw should be oiled, and the wheel that runs on a steel plug under the dial should be oiled; as, if rusty, it sometimes unscrews when setting and breaks the dial. The cylinder should be oiled, but the less the better on nearly all parts of a watch as long as it is oiled. Use the best oil.

**Broken Teeth.**—The best way to replace a broken tooth is to discard the wheel and supply a new one. To replace a broken tooth in a barrel, drill in about one-eighth of an inch with a drill smaller than the thickness of the back of barrel; tap the hole and turn a piece of brass wire to fit the hole; cut thread and screw in, then file down to match the center pinion.

**Oiling the Balance.**—Before putting in the balance, oil all the pivots, and be very particular to apply the right quantity of oil, for the steady rate of the watch depends a great deal upon the oil being preserved unchanged; hence we should use the best oil and apply it so that it will stay where it belongs. After oiling the balance holes, insert a fine peg, which will carry the oil down to the end stone; then add a little more.





TRADE MARK.

# L. STRAUS & SONS,



TRADE MARK.

IMPORTERS AND MANUFACTURERS,

China, Pottery and Glassware, 42, 44, 46 & 48 Warren St. and 116 Chambers St., N. Y.  
PARIS, CARLSBAD, RUDOLSTADT, LIMOGES, STEINSCHONAU.

**WOOD & HUGHES,**  
STERLING SILVERWARE MANUFACTURERS  
New York Agents for the Derby Silver Co.'s  
FINE QUADRUPLE PLATED WARE,  
No. 16 JOHN STREET, NEW YORK.  
206 Kearney St., San Francisco, Cal.  
HASKELL & MUEGGE, Agents.



## IRONS & RUSSELL,

(SUCCESSORS TO CHARLES F. IRONS.)

MANUFACTURERS OF  
SOLID GOLD **EMBLEMS** ROLL PLATE  
PINS, CHARMS AND SOLID GOLD RINGS.

102 Friendship Street, - - Providence, R. I.



# The "Bryant" Rings.

Are widely advertised and will sell  
when anything will, therefore  
every Retail Jeweler should buy them.

IF NOT CALLED UPON BY OUR TRAVELERS  
ORDER DIRECT FROM

**M. B. BRYANT & CO.,** - 10 MAIDEN LANE. N. Y.  
OLDEST RING MAKERS IN AMERICA.



ESTABLISHED 1870.

## J. L. CLARK,

SWEEP SMELTER AND REFINER OF GOLD AND SILVER  
Buys every kind of Gold and Silverware, Jewelry, Watches and Platium. Full market value paid.

No. 724 Filbert Street, Philadelphia, Pa.

SEND BY EXPRESS or Registered Mail. If my price is not satisfactory, I will return all articles.

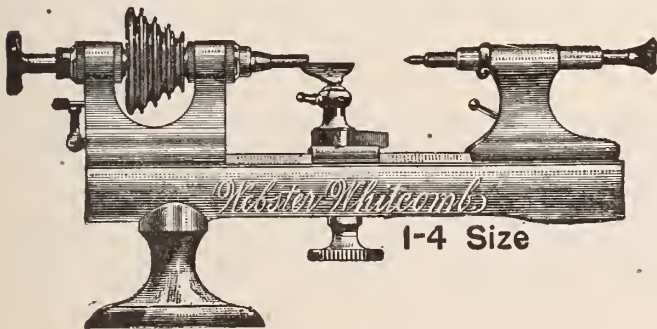

STRONGEST GUARANTEES.

Quality  
Maintained.

Prices to  
Suit the Times.

Ask for our New  
Prices and  
Terms for 1894.

## American Watch Tool Company,

Chymistry Dist., Waltham, Mass., Stoney Batter Works.

A Full Line  
OF ALL  
AMERICAN  
WATCHES.

**MAX FREUND & CO.,**  
Importers of Diamonds and Precious Stones,  
AMSTERDAM: 8 MAIDEN LANE,  
TULPSTRAAT 9. NEW YORK.

SPECIALTY:  
DIAMOND  
JEWELRY  
of our own design.

## VICTOR. ⊗ ⊗

SIMPLEST FEED. ALWAYS THE SAME.  
GUARANTEED FOR ONE YEAR.

## THE VICTOR FOUNTAIN PEN

(Pat. Feb. 4, 1890.)

THE BOSTON PEN CO.,

N. C. Whitaker & Co., Proprietors.

363 Washington Street, Boston, Mass.,

Manufacturers of finest quality

TORTOISE : SHELL : AND : HORN : GOODS

in every variety. Also Aluminum Hair Pins.

Send for Illustrated Pen Price List No. 1.

LOOKING FOR THE

## COLUMBIAS?

AN ADJUSTABLE EYE-GLASS THAT  
CAN'T BREAK NOR GET OUT  
OF ORDER.

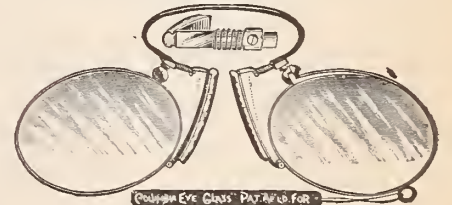

DON'T BUY UNTIL YOU SEE ONE OF OUR  
COLUMBIAS.

## E. KIRSTEIN'S SONS CO.,

SOLE MANUFACTURERS,

ROCHESTER, NEW YORK.

Send us your Rx. work, when you want same at once.



# FERDINAND BING & Co.,

106 GRAND ST., N. Y.

—\*—NEW DESIGNS IN—\*

China Clocks and Gilt Bronze Sets, Fine Painted Dresden Goods in  
Vases, Cups and Saucers, and Plates; Cararra Marble Statuary,  
French Cabinets and other Fancy Furniture.

**CHRYSO-CERAMICS,**  
GOLD COVERED PORCELAIN.

**M. & E. HEALEY,**  
1122 CONNECTICUT AVE., WASHINGTON, D. C.  
MEDAL AT WORLD'S COLUMBIAN EXPOSITION.

**S. C. JACKSON,** 180 BROADWAY, NEW YORK.  
MANUFACTURER OF

Fine \* Cases \* for \* Jewelry, \* Silverware, \* Etc.

ALSO SHOW CASE TRAYS AND FANCY HARD WOOD WORK  
Samples sent on application. Estimates furnished

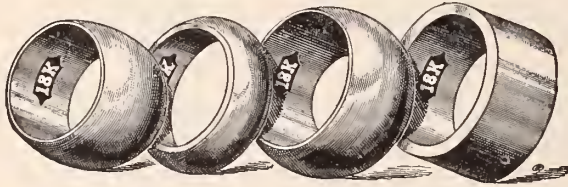

Band Rings metal lapped. Full value allowed for old gold.

**PLAIN SOLID GOLD RINGS.**  
**HILDRETH MFG. CO.,**

53 MAIDEN LANE,

NEW YORK.

## Paper Boxes

At Prices Which Defy  
Competition.

Plain and Fancy Silverware Boxes  
FOR MANUFACTURERS USE  
OUR SPECIALTY.

Our large dealings in Satins, Silks  
and Saleens in the Corset Business,  
together with special machinery, enable  
us to do the BEST OF WORK AT LOW  
PRICES. Quotations promptly fur-  
nished upon receipt of sample.

Address

Warner Bros.,

Bridgeport, Conn.

Box Department.



# CHARLES AHRENFELDT & SON

50, 52 & 54 Murray Street, New York.

.... IMPORTERS OF ....

**China, Glass AND Bric-a-Brac,**

ESPECIALLY ADAPTED TO THE JEWELRY TRADE.





### Art in Electric Lamps.

IN no branch of industrial art do we notice so great a variety of designs as there are among electric light apparatus. A handsome jardiniere resting on a column contains flowers in gilt silver with tiny electric light globes half covered by the petals of the flower. A pretty maid in bronze standing on tiptoe on a rock, holds up in both hands several torches. A heron holds in his upturned beak a cluster of



ELECTRIC LAMP, BY M. PLANCHON.

reeds with a narrow globe at the end of each reed, etc.

Among these patterns some are very original, for instance, that shown in Fig. 1 reproducing one of Planchon's electric lamps to rest on the writing table of a library. A sturdy boy, seated on a square block, holds with his two hands a thick stick, like a ruler, supporting a lamp shade which resembles a parasol.

Some are designed and executed by thorough artists. Such is the *appliqué* shown in Fig. 2. This is one of the most spirited works of Chéret, sculptor, who has created so many remarkable works in porcelain at the Sèvres manufactory, in bronze, and in silver. This *appliqué* consists of eight

infants, all held together by a loose scarf caught around the branch of a tree of wonder. Three of these boys, who have plucked pretty flowers are brandishing them in a proud or joyful manner. One, on the left hand side, is trying, half coaxingly and half imperiously, to snatch a flower from the hand of his fair little companion. Higher up, two infants are fighting against a third one, who is evidently endeavoring to get enough of the fascinating flowers to make a bouquet. This scene is full of real life, yet all the parts are so arranged that the ensemble is absolutely symmetrical, the diagram of this artistic *appliqué* being a perfect lozenge.

### The Art of Glass Cutting.

WE do not hesitate to designate glass cutting as an art, and it is a recent art, too. We do not remember that it was ever practiced by the Venetians, who must have credit for great expertness in glass making, but in glass making only.

He must have been a first-class mechanic who attempted to cut glass, and his early experience must have been with the foot or by hand labor, for it preceded steam power. Again, his adopting the stone wheel was an invention, be it for the flat lapidary cutting or the cutting on the face of the stone; and then his polishing, either by the pewter or the wood, was an invention, too, and an invention of much forethought and ingenuity.

Imagine the glass wrought by blowing as we see it in our museums; it was a primitive method, even with their ingenious twistings and manipulation on the marver, by running hot metal into fantastic shapes and then sticking them up into legs of drinking glasses and other fancies. This was only a primitive history of glass-making; it was when the glass cutter came to the rescue that glass was made beautiful, and this was perfected when grand lead metal replaced the lime body which is the characteristic of all the early glass, even including the Venetians.

How short a time is it that glass cutting has been practiced! and whether it be best done by the Prague artist, or by the English, is a matter for the historian; but it is an invention certainly of the last two, and

probably not much more than three, centuries; and the early glass cutting was most primitive—indeed, it scarcely, until 150 years ago, could be called an art at all.—*Pottery Gazette*, London.

Some of the ugliest conceivable terra cotta vases are being sold by decorators, for the purpose of supplying ladies with a material on which to exercise their amateur powers as painters of barbotine ware. A twist here, a turn over there, a blow in the center, or



ELECTROLIER ATTACHMENT, BY J. CHÉRET.

an ugly crush, is supposed to be the perfection of artistic taste. Ladies waste days over painting these wretched abortions, and get complimented by others for the marvelous artistic genius they are supposed to display. Take again the new terra cotta plaques. These are the perfection of square shaped ugliness. They have neither top, bottom, nor sides, but simply resemble a number of pieces of old iron, sheared, and torn, and twisted, and turned out of all recognizable shape. No name in fact can be given to the shape of these abortions. They do not look so bad, however, after being duly prepared and painted on, especially if the subject chosen happen to be a bright or cheerful one.



## The Connoisseur.

(Continued from page 39.)

### The Rambler's Notes.

WHAT THE RAMBLER SAW AND HEARD AMONG THE DEALERS IN ART POTTERY, CUT GLASS, BRONZES ETC.

**NOVELTIES IN FRENCH AND DRESDEN CHINA.** **N**OVELTIES for the table, boudoir, cabinet, desk and mantel, abound in the French and Dresden china lines to be seen at Bawo & Dotter, 30 Barclay St., New York. In the French goods, the bonbon boxes, fancy trays, egg-cups and sets show some delicate floral and gold decorations. Among the newest pieces in the Dresden novelties are brush backs, beautifully decorated china panels for the backs of hair and clothes brushes. The Royal Wettin line shows a varied assortment of flower holders and plates decorated in Empire green and gold.

**A NEW SERIES OF PORCELENE CLOCKS.** **T**HE F. KROEBER CLOCK CO., 360 Broadway, New York have decided to introduce a new series of mantel Porcelene clocks suitable to the times. Taking into consideration the present condition of business which causes a demand principally for low priced goods,

they will in addition to the various new designs just introduced soon put on the market, a line which though the prices are moderate, will be of improved quality and shape.

**NOVELTIES IN PATE SUR PATE.**

**H**ANDSOME novelties and fancy articles with decorations in *pâte sur pâte* are to be seen in the warerooms of Chas. Streiff, 31 Barclay St., the New York agent for the china of Wm. Guerin & Co., Limoges, France. *Pâte sur pâte*, as is well known, is a decoration, formed by means of porcelain paste applied upon a previously prepared substance so as to produce *bas relief* effects. The paste is pure white, and the different thicknesses produce different degrees of translucency and whiteness. In the pieces here shown, the white porcelain is on a colored ground, and the execution in the figures of the decoration, principally angels and cupids, is perfect. Among the colors of the bodies which these adorn are Russian green, pink, maroon, chocolate and chamois.

**THE POPULARITY OF VICTORIA WARE.**

**T**HE Victoria ware of Lazarus, Rosenfeld & Lehman, 60 Murray St., New York, becomes each year more popular as a line for jewelers. A feature of the line this year is the great number of new shapes and decorations. One of the prominent new decorations con-

sists of bunches of pink and blue lilacs on an ivory ground; another shows scrolls of conventionalized flowers on a similar ground. Among the most striking pieces are those with large forget-me-nots outlined in gold on an embossed ivory body with a deep border of delicate pink and spotted gold, and the large vases and flower holders in shaded Empire green with floral decorations. A specialty has been made this year of large and small violet and bouquet holders and vases. A new feature seen in almost all these pieces are the gold rococo handles. Pieces entirely new to Victoria ware are the trinket, jewel, boudoir, desk, ice cream and tête-à-tête sets, the bon bon dishes, trays, jewel boxes, and other table, cabinet and mantel novelties, which have just been introduced. **THE RAMBLER.**

An attractive little patent in the jewelry line is one of the novelties now shown by jewelers. It is that useful thing, the calendar, made perpetual, and worn as a watch charm, and is either the shape of a small, dainty acorn, or Maltese cross. When a person wants to know the day of week or month, on the street, traveling or where not, he simply consults the charm from which he is never separated. It also shows at a glance what day of the month any week day falls upon. The novelty is useful and ornamental, and has had quite a success. Irons & Russell, Providence, R. I., are the makers of this taking device.

# A. A. VANTINE & Co.,

877 & 879 BROADWAY,  
NEW YORK, N. Y.



200 & 202 MADISON ST.,  
CHICAGO, ILL.

**Largest Importers** JAPAN, CHINA, INDIA, TURKEY, PERSIA.

THE LARGEST LINE OF EXTREME NOVELTIES.

**SILVER** Oxidized repoussé effects in metal ware.

**GOLD** and Platinum repoussé effects in metal ware,

**I**N Stamp Boxes, Bon-Bons, Button Hooks, Pen Trays, Card Trays,

**O**VER \$40,000 of these goods were sold in Bijoutiers of the Midway Plaisance.

Unique articles in China which makes our retail department so popular throughout the country. Our full line of Water Color Fans, Paper, Parchment, Silk, Satin, Ivory, Sandal Wood. **SAMPLES UPON APPLICATION.**



**DECORATIVE**  
**ART**  
**GOODS.**

Bric-a-Brac,   
 Marble Goods,  
 Onyx Clocks,  
 Bronzes,  
 Statues,  
 Choice  
 Porcelains,  
 Fine  
 Furniture.

**JEWELERS'**  
**SPECIALTIES.**

SILVER  
 Filigree Jewelry,  
 Petite Bronzes,  
 Bijou Clocks,  
 Opera Glasses,  
 Cloissonné,  
 Chamois Skins.



IMPORTATIONS OF SPECIAL INTEREST TO JEWELERS AND ART DEALERS.

**GEO. BORGFELDT & CO.,**

18, 20, 22 WASHINGTON PLACE, Cor. Greene St.,

**NEW YORK.**



## The Other Side of Life.

ONE OF THE FIRM.

"Who's the 'Co.' in your firm?" asked Smasher of his friend, the jeweler.

"My wife."

"Ah, she's a silent partner, is she?"

The jeweler rubbed his chin for a moment.

"Well," he replied in some doubt, "she ain't so all-fired silent when you come to think of it."

THE WATCH WAS LOADED.

The examinations at a certain "prep." school were in progress. The boys were working busily over their papers, and the grim old professor was watching sharply from his desk.

Presently he noticed that one of the students, a prominent ne'er-do-well, was consulting his watch with considerable frequency. The professor studied him. In five minutes he had looked at the timepiece three times.

This was enough for the guardian. He called the student to his desk and demanded the watch. It was given him and he opened it. Across the face was a piece of paper bearing the legend "Fooled."

But the worthy professor was not to be so easily deceived. He gave the student a sharp, knowing glance, turned the timepiece over and opened the back cover. It opened with considerable difficulty, and be-

hold, there was another slip of paper bearing the information, "Fooled again, old fogy."—*Boston Budget*.



HIS ONLY HOPE.

JEWELER.—I can't let you have another engagement ring, Mr. Upton. You owe me for three already.

HARDY UPTON.—You'd better let me have this one, too. If this goes, I'll be in a position to pay for the others in a few months.—*Puck*.

## Appropriate Names of Jewelers.

A WRITER in the *Outlook*, New York, says: One of my obliging correspondents writes, "That A. Diamond & Co., in Park Row should be pawnbrokers is perhaps only proper." A. Diamond might easily find it hard to keep out of a pawnshop. This reminds me, he continues, that it is interesting, on the negative side, to observe that there is not a jeweler among all the Diamonds, Diamants, Diamands, Diamonts, Diamondsteins, of the directory; neither among Perlman's, Perlmann's, Perlsteins, Perlmutter's, Perlhefters (a sad misfortune, this last!), nor Rubys, Saphirs, Saphirsteins, etc. On the other hand, one of the "honorable women" who have lent their aid to these papers writes: "Golden & Châtelaine are jewelers in Virginia City, Nev., having a branch of the business conducted by Mr. Golden alone in Carson."

"As for the pawnbroker here mentioned, we have to note the saving power of his '& Co.' A. Diamond, standing alone, would suggest but a pitifully mean scale of business; but A. Diamond & Co. opens wide the door to imagination; all "the wealth of Ormus and of Ind" may be included in that "Co.," which is capable of affecting the mind like the sign of the public-house in "Pickwick," which displayed "a large black board, announcing in white letters to an enlightened public that there were 500,000 barrels of double stout in the cellars of the establishment"



SPECIAL SALESMAN OF

## WATCHES, DIAMONDS.

Bric-a-Brac  
and Art Goods

FOR

## Established Jewelers.

WRITE FOR PARTICULARS.

Communications Strictly Confidential.

References given in all parts of the United States from Retailers and Jobbers.

## Enterprising Jewelers Catch On!



OBVERSE



REVERSE



BACK

## Jewish Sheckel, Masonic Mark or Pocket Piece.

THE LATEST AND BEST SELLING NOVELTY.

The mark is struck in coin silver; by using either the obverse or reverse of the coin, the back being the same in either case, and permitting of the purchaser's name, blue lodge, chapter and individual mark, with date of same being engraved thereon, as shown in cut above.

Price, without engraving, ONE DOLLAR. Engraved Mark, Dates, etc., 75c. EXTRA.

Liberal Discount to the Trade.

CHAS. G. WILLSON, MANUFACTURING JEWELER, READING PA.

**Three Great Successes.**

Our Industrial School of Optics Practical  
Our Swell Gold Construction Progressive  
Our Prescription Department Functional

**ASSURED SUCCESS TO YOU**

If you take the Practical course in refraction, sell The Swell End Eyewire Gold Spectacles and Eye Glasses, and send your Prescription work to our special department which you will find accurate and punctual.

Avoid delay and errors by keeping in mind the old reliable

**Spencer Optical M'g Co.**

15 MAIDEN LANE, NEW YORK.

Send for Samples.

## Belts AND Buckles.

Elegant designs. Prices as low as the lowest. Hair Pins, Link Buttons, Ladies' Combination Shirt Waist Sets and all the latest in STERLING SILVER NOVELTIES.

MANUFACTURED BY

## CODDING BROS. & HEILBORN.

North Attleboro, Mass.

Chicago office, Buck & Hall, 103 State St., Rm. 802.  
New York office, C. A. Vanderbilt, 178 B'way.



# HINRICHS & CO.,

29 AND 31 PARK PLACE,  
NEW YORK.

## BRIC-A-BRAC AND ART POTTERY.

NEARLY A CENTURY OLD.

E. GÉRARD, DUFRAISSEIX & CO.,  
SUCCESSORS.

FABRIQUE FONDEE EN 1797



THE

CH. FIELD HAVILAND  
LIMOGES CHINA

IS MARKED:

WHITE WARE,



DECORATED



NEW GLAZE COLORS  
(FURNACE FIRE),



HAVILAND & ABBOT, { O. A. GAGER & Co.  
CHAS. FIELD HAVILAND & Co.

IMPORTERS OF CHINA,

P. O. Box 505.

29 BARCLAY STREET,

NEW YORK.

AGENTS FOR

E. GÉRARD, DUFRAISSEIX & CO.,  
LIMOGES.

NEW YORK OPEN STOCK.

We carry at all times a large assortment of the "Chas. Field Haviland" china in white and decorated goods, to repack for immediate shipment or for sale in original casks. Have now sixteen *open stock* decors and are constantly adding new designs.

IMPORTATION SAMPLES.

The newest and choicest designs always to be found in our import rooms. Novel forms and tasteful decors.

New York Sample Rooms, - - No. 29 Barclay Street.

PATENT paneled METAL

## CEILING

Stamped Raised Panels.

ARTISTIC AND PERMANENT.

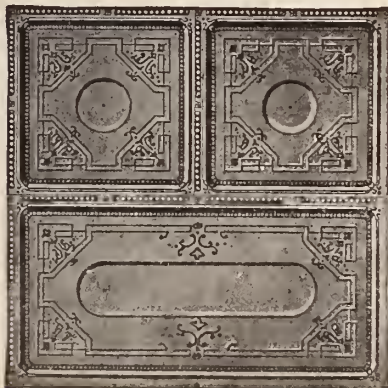

Easily applied in new buildings, and over old broken plaster or wood Ceilings. If interested in building or repairing, send stamp for Illustrated Catalogue, and state if CHURCH, HALL STORE, OFFICE, or SCHOOL Ceiling is wanted. Address

A. NORTHROP & CO., Pittsburg, Pa.

## "Old English"

Coffee Spoon.

\*\*\*



DESIGN PATENTED.

Towle Mfg. Co.,

MANUFACTURERS OF

STERLING SILVERWARE.

NEWBURYPORT: No. 214 Merrimack St. CHICAGO: Nos. 149 & 151 State St.

AWARD AT WORLD'S FAIR, CHICAGO, 1893

The Providence Shell Works.

W. K. Potter,

346 Westminster St., Providence, R. I.

W. K. POTTER,  
TORTOISE SHELL WORKS PROV. R. I.



Tortoise Shell Goods, Combs, Hair Ornaments, Jewelry, Etc.

Shell Work made to order on contract. Repairing for the trade in all its branches.

If Your Sales  
Are Not Satisfactory

ADDRESS

DE B. O. SCOTT,

20 Murray Street, New York.

AUCTIONEER.

Specialties: Watches, Clocks, Bric-a-Brac, &c.

Write for particulars and references.



**B. & W. B. SMITH,**

220 W. 29<sup>TH</sup> ST.,  
NEW YORK.

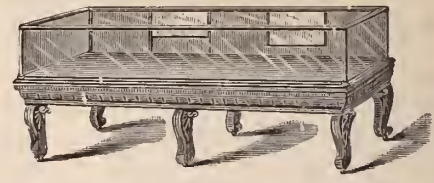
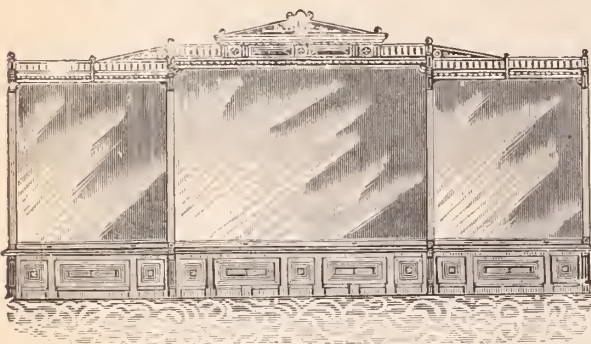

Dust Tight Wall Cases. Improved system of Shelving and Electric Wall and Counter Cases Lighting.

IMPROVED DUST TIGHT.

◁ SMALL CASES FOR SPECIALTIES ▷

ALL GLASS.

NO MOULDINGS

**S. F. MYERS & CO.,**

WHOLESALE JEWELERS,  
MYERS BUILDINGS, - - NEW YORK.  
1894 ISSUE, No. 38,

**OUR ROYAL CATALOGUE**

Illustrates all that is new, unique and desirable in everything that pertains to jewelry.  
Sent free to dealers who have not received it.

TWENTY-TWO DEPARTMENTS.  
SEVEN DOUBLE FLOORS.

Myers Buildings, 48-50 Maiden Lane, New York, 33-35 Liberty St., New York.

**J. SCHAWEL & CO., 29 John St., N. Y**

GOLD & SILVER REFINERS, ASSAYERS & SWEEP SMELTERS.  
STERLING SILVER, 925/1000 FINE IN SHEET AND WIRE.  
Soft Platinum, Sheet and Wire for Manufacturing Jewelers.

**VACHERON & CONSTANTIN,**  
GENEVA, SWITZERLAND.



FINEST QUALITY OF WATCH MOVEMENTS, FITTING ALL SIZES OF AMERICAN CASES.



**EDMOND E. ROBERT,**

Agent for the United States and Canada,  
21 & 23 MAIDEN LANE, NEW YORK.

**S. P. HOWARD,**  
Gold and Silver Assayer,  
Refiner and Sweep Smelter,  
33 MAIDEN LANE, NEW YORK.  
Smelting and Refining Works,  
28 & 30 Cumberland Street, Brooklyn, N. Y.  
Specialties: Sweepings, Gold, Silver and Platinum

**ALBERT BERGER & CO**  
47 MAIDEN LANE, N. Y.  
Spectacles & Optical Goods,  
GROUND LENSES A SPECIALTY.

**Headquarters**  
FOR  
ELECTRIC & PORTABLE  
Watchman's Clocks  
Lowest Prices.  
Latest Improvements,  
Patents 1888-1893.  
Send for Circular.  
**E. O. HAUSBURG,**  
41 Maiden Lane, New York. "THE 'ALERT.'"  
Price, Complete \$10.00



**A.W.C.CO**

**AMERICAN WATCH CASE CO.,**  
MANUFACTURERS OF GOLD CASES.

11 JOHN ST., NEW YORK FOR THE RETAIL TRADE.

**WM. BIRMINGHAM & CO.,**  
MANUFACTURERS OF  
All Kinds of Leather Spectacle and Eye Glass  
**CASES,**  
728 Arch Street, PHILADELPHIA, PA.

**J. PRINCE,**  
Jewelry Auctioneer,  
At liberty from January 1st, 1894. Retail  
Jewelers only. Address,  
Rooms 9 & 10, 137 BROADWAY  
N. Y. CITY.



FRENCH ENGLISH  
CLOCKS AND HALL CLOCKS AND  
MATERIALS. MATERIALS!

**CHAS. JACQUES CLOCK CO.,** 22 CORTLANDT ST., N. Y.

**AMERICAN RAILWAY SUPPLY CO.**  
24 Park Place, NEW YORK.

**IT PAYS** TO KEEP IN TOUCH WITH TRADE AFFAIRS. **THE JEWELERS' CIRCULAR** For 4c. a Week will do it. **Subscribe.**

1869-1894=Twenty-five Years Oldest, Best Brightest, Newest, =The Jewelers' Circular.





# THE JEWELERS' CIRCULAR

AND HOROLOGICAL REVIEW.

Copyright by THE JEWELERS' CIRCULAR PUB. CO.

189 Broadway, New York.

Entered at the Post Office in N. Y. as second-class matter.

VOL. XXVIII.

NEW YORK, WEDNESDAY, APRIL 4, 1894.

No. 9.

## ART IN THE CONSTRUCTION OF CLOCKS.

ACCOMPANYING illustration represents a clock which was awarded with a prize at the last Paris International Exposition. It was built by L. Falize Frères, of Paris, with the co-operation of the sculptor Carrière-Belleuse, and attracted universal attention on account of its great beauty and artistic execution.

The timepiece is 540 millimeters (21.27 inches) high. The clock work is located in the foot, which consists mainly of lapis lazuli, with inserted chased reliefs. The several architectural adornments, especially the six abutting figures, are most richly and tastefully gotten up in colored enamel. The hours are shown through a perforated medallion, while the minutes are visible below through the foot. The constructive and mechanical get-up of the movement is hidden from view, which considered from a purely æsthetic standpoint, is an advantage.

Upon the pedestal stands a charming decorative group: Urania, the muse of astronomy, with two infants. The figures of this group are of ivory, the drapery and head ornaments of gold and silver; the contours and posture of the entire group are by connoisseurs acknowledged to be perfect. The goddess Urania points to a globe made of rock crystal, the equator of which contains the zodiac, of gold and silver; the twelve constellations are contained in enameled medallions.

The time consumed in constructing this clock, of finished workmanship even in its smallest detail, was not stated to the writer. No matter how closely the whole may be scanned, the examiner will constantly discover new beauties and a harmony of details that

stamps this work of art as a masterpiece, to be admired by lovers of the beautiful



A PRIZE CLOCK, BY L. FALIZE FRÈRES.

in the coming centuries. It is well worthy of study by all horologists.

### The Great Clock of Rouen.

THE great clock, the pride of the people of Rouen, cannot perhaps claim to be the most ancient in France; that of the Palais de Justice, and the great clock of Caen, may justly claim to dispute with it the honor of antiquity; but it is certainly true that none other can compete with it in perfection of construction. A clock, which has practically been going regularly, and striking the hours and quarters for over five hundred years, may fairly be regarded as a valuable piece of mechanism, especially in this epoch when a pendulum which has been going fifty years is considered a marvel. The great clock of Rouen stands unrivaled in this respect.

Finished in September, 1389, by Jehan de Féalins, it has been running without interruption from that day to this, requiring nothing except cleaning, and a few trifling repairs of its accessory parts. It was certainly not with this clock that the famous proverb originated: "This is the palace clock which goes when it pleases." On the contrary, the great clock of Rouen had so accustomed the citizens to look upon its exactitude as a matter of course, that when, in 1572, the breaking of a wire prevented its sounding five o'clock one morning, the population was in a state of consternation. The magistrates summoned the custodian, Guillaume Petit, and remonstrated gravely with him.

This unparalleled course from century to century is all the more remarkable, from the fact that until 1712 the Great Clock had no pendulum. For 325 years, it had no other regulator than a "foliot," an apparatus of



# DEITSCH BROS.,

7 EAST 17TH ST., NEW YORK.

## LEATHER GOODS.

EBONY AND SILVER COMBINATIONS.

ORIGINATORS AND MAKERS OF

NOVELTIES IN LEATHER AND STERLING SILVER COMBINATIONS.



\*\*\*\*\*

**CROSS & BEGUELIN,**

17 MAIDEN LANE, NEW YORK,

\*\*\*\*\*

ALL GRADES OF SWISS AND AMERICAN WATCHES, DIAMONDS, GOLD AND ROLLED PLATE JEWELRY, OPERA AND FIELD GLASSES, TOOLS AND MATERIAL.

SOLE AGENTS FOR THE **Rockford Watch Co.** MATERIAL.

MANUFACTURERS OF THE **Centennial Watches.**

SEND FOR OUR WATCH MATERIAL AND TOOL PRICE LIST FOR 1894.

\*\*\*\*\*

### AMERICAN SYNDICATE OF Jewelers' Auctioneers.

ESTABLISHED for the sole purpose of conducting sales for established Jewelers in the United States, Canada and Mexico. We do not sacrifice your goods. We take no sales on a percentage. Our terms are strictly one-half the profits realized on all goods sold. We guarantee you against any loss. We pay all our own expenses; we don't ask you to pay one cent of expense on our account. We buy stocks complete as well as sell them. If your stock is small, or your assortment is not complete, we will furnish from one to ten thousand dollars worth of any kind of stock you may need and in which you need not invest one penny. Don't make any arrangements with others until you read our pamphlet which we will send you free, giving you full particulars of our style of doing business, and the liberal offers we make to Jewelers. We don't care how small your stock is, we will furnish all the stock you need to make a successful sale. We challenge the world for any fairer or more liberal propositions than we make Jewelers. Don't fail to send us your address, and we will send you our business pamphlet, which gives you full explanations as to our terms and style of doing business. Address,

### AMERICAN SYNDICATE OF JEWELERS' AUCTIONEERS.

20 WEST 14th STREET, NEW YORK. OFFICES: } 611 PENN AVE., WASHINGTON, D. C.

### "THE BEST BUTTON MADE."

THE KREMENTZ

IN GOLD

IN ROLLED PLATE

FROM

KREMENTZ & CO.

ONE PIECE

FROM

ALL JOBBERS

AND ALL JOBBERS.



### COLLAR BUTTON.

IS THE ORIGINAL ONE PIECE BUTTON.

IS STILL THE BEST AND STILL UNSURPASSED.

Sold by all wholesale dealers at manufacturer's price.

A. N. CLARK, PLAINVILLE, CONN.

Manufacturer of the Celebrated

### LOOP WATCH KEY.

The Best for the Price in the World. CROSBY'S JEWELING TOOLS IMPROVED.

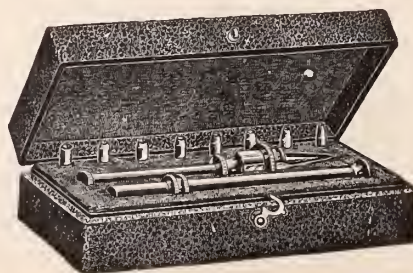
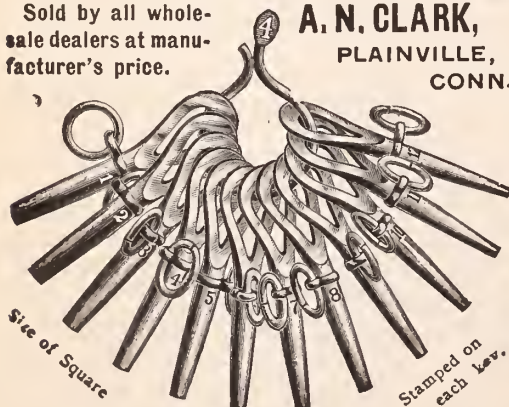

Will quote royalty or price for the manufacturing of articles of real worth.

### CAMPBELL-METCALF SILVER CO.

Choice Conceits IN Sterling Silver ONLY.

2 Maiden Lane, N. Y., with Holmes & Edwards Silver Co, 66 Stewart St., Prov., R. I. Mills Bldg., San Francisco, 8th Floor, Room 1.

JACOT & SON IMPORTERS AND MANUFACTURERS OF MUSICAL BOXES

39 Union Sq., New York.



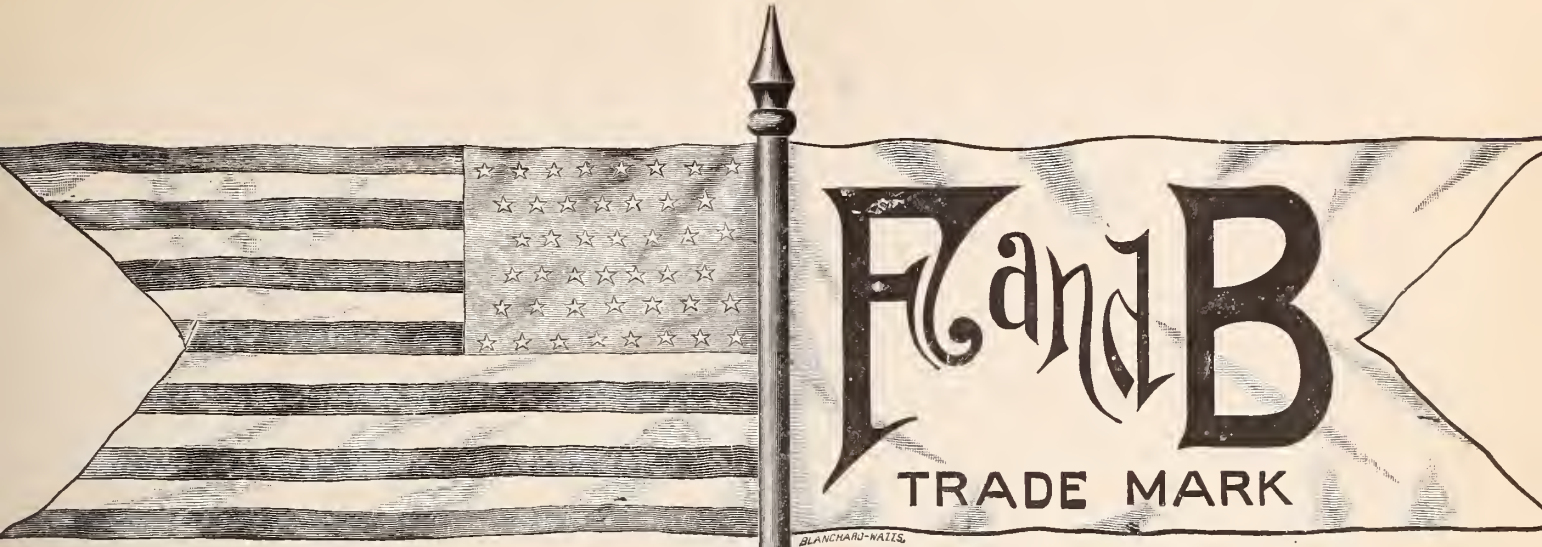

Our American F. & B.  $\frac{1}{10}$  Gold Chains will assay 10 K. 1-10 gold, and are guaranteed for ten years.

Our regular line of Chains is made of heavy gold plate, finely finished, and guaranteed for five years.



**Chains**

Our new line of chains will assay 10 karat 1-10 gold. All gold soldered.  
**American F. & B. 1-10 gold.**

WE RECEIVED  
**4 MEDALS**  
AT THE WORLD'S FAIR.

**Mount Hope Button.**



CLOSED.

**Watch Chains for Gentlemen**

These goods are of fine quality, and guaranteed to give satisfaction. Some recently added have sold far beyond expectation. They are made of heavy rolled plate in all sizes and patterns.

**Watch Chains for Ladies**

Our Victoria and Princess chains are neat and pretty. They are made in all bright, Roman and bright, platinum and bright gold, and have one or two charms.

**Mount Hope Button**

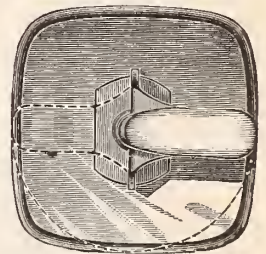

OPEN.

**Charms**

This line is adapted to ladies' or gentlemen's chains, and includes a number of heart charms in Roman, bright and satin finish, with stones and without.

**Hair Chain Mountings**

In solid gold and rolled plate. We are headquarters and make every thing desirable in this line.

**Bracelets**

We make a large stock of curb bracelets in five sizes, besides the graduated links, with padlocks and snaps, in chased and plain polished, Roman, rolled silver plate and sterling silver. Also padlocks with keys and a push snap.

**Pins**

Our large line of lace and cuff pins comprise many desirable patterns in gold fronts engraved and trimmed. Also includes baby pins and scarf pins.

**"Mt. Hope" Buttons**

These are superior to any button in the world. They are easy to put in and easy to take out of the cuff.

**Link Buttons**

This line has increased rapidly with us, and is very low in price, embracing all styles in Roman, chased, engraved and plain, with and without stones, and some in enamel.

**Crosses**

We make four sizes of gold filled in plain, engraved and set with stones, and suitable for our neck chains.

Sterling Silver and Solid Gold Sword Scarf Pins

**Glove Buttoners**

We make the interlocking and one with a twist handle in gold rolled plate and silver rolled plate.

**Earrings**

This line includes many pretty patterns in gold fronts engraved, some with pretty trimmings and a small line of hoop drops.

**Neck Chains**

We make a variety of neck-chains in bright and Roman, with snaps.

Sterling Silver Bracelets and Padlocks

**Gold Locket Set with Diamonds**

These lockets are made of 10 karat gold throughout and set with brilliant diamonds. They cannot be surpassed in finish or cheapness of price.

**Gold Locket Engraved**

These lockets are also made of 10 karat gold throughout, with beautiful designs engraved thereon and the price is so low that they cannot fail to be in great demand.

**Gold Front Locket**

This line is very extensive. Many patterns are plain polished, others nicely engraved, with and without stones.

**Rolled-Plate Locket**

This line is almost endless, and consists of nearly every conceivable shape, size and style. Some are set with imitation diamonds, rubies and sapphires.

We have put upon the market a line of Gentlemen's Chains and Ladies' Chain Bracelets made of 1-10 gold stock. Every joint is soldered with gold, and every Chain or Bracelet will assay more than 1-10 gold. They are our AMERICAN F. & B. 1-10 GOLD goods, and are so stamped. Bar, Chain and Swivel are stamped 1-10 gold.

**FOSTER & BAILEY, Providence, R. I.**



which the majority of modern clockmakers hardly know the name. Its function will readily be gathered from the cut. A vertical rod A, suspended by a cord B, supports a transverse beam G, the arms of which terminate in a serrated edge. On these serrations are movable weights P, P, called "reg-

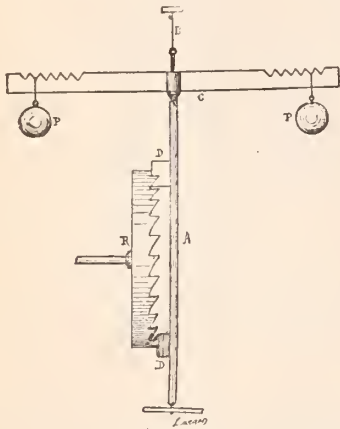

FOLIOT. OLD BALANCE OF THE GREAT CLOCK OF ROUEN.

ulators," which by change of position augment or diminish the force of inertia of the machinery. To the rod A, are attached two spurs D, D., which receive alternately the impulsion of the teeth of the balance wheel R, operated directly by the clockwork. The special characteristic of this regulator is the absence of that which constitutes the essen-

tial feature of the pendulum, namely, a natural point of inertia. It might be said of it, that then it was a clock capable of regulating its regulator with a nicety determined by the degree of the precision of the cutting of the teeth of its balance wheel.

The case of the clock occupies a space of 6 feet 8 inches long, 5 feet 4 inches broad, and 5 feet 10 inches high. Our illustration represents one of the two faces of the Tower of the Great Clock, constructed in 1389. When one thinks of the size, and of the labor of construction, by hand, of the great wheels of this admirable piece of mechanism, it may easily be inferred that the maker, Jehan de Félaïn, had ample time to eat up all the little sum he was paid.

The pendulum was introduced into clockwork in 1659; but so well were the good people of Rouen satisfied with the time-keeping qualities of their famous old clock, and such was their veneration for this masterpiece of mechanism, that 53 years were allowed to pass before the pendulum was substituted for the "foliot." Equipped with this new apparatus, it has continued to this day to strike the hours and chime the quarters.

In 1892 the Commission of Historical Monuments decided on the restoration of the dial and of the two accessory movements of the Great Clock which show the days of the week and the phases of the moon.—R. REVERCHON, in *Cosmos*, PARIS.

**A Brace of Jewelry Store Burglars Escape From Jail.**

BELVIDERE, N. J., March 28.—Harry Laire and Charles Dorsey, two well known burglars, escaped from the Warren County

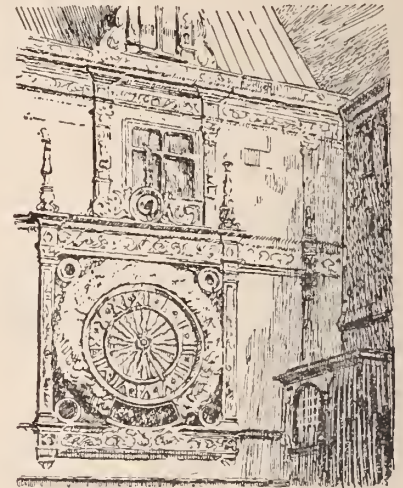

THE GREAT CLOCK OF ROUEN.

jail Saturday night by climbing through an aperture in the top of a cell to which they had access. The hole had been made by prisoners who had previously escaped. The prisoners, after reaching the street, started for the Delaware River, where they secured a boat and rowed to the Pennsylvania shore.



**GEO. W. SCHIEBLER & CO.**  
SILVERSMITHS

179 BROADWAY, N.Y.

**BIG RETURNS MADE FOR OLD GOLD AND SILVER.**

Check Forwarded 24 Hours After Receipt of Consignment.

**J. RATHBONE,**

GOLD AND SILVER REFINER. ASSAYER AND SWEEPSMELTER,

Nos. 1 to 9 Matthewson St., Cor. Cove, Providence, R. I.

**Paul Jeanne,** EIGHTEENTH STREET and 4<sup>TH</sup> AVE., N. Y.  
(Bradley Building.)

MANUFACTURER OF

≡ FINE ⊗ DIAMOND ⊗ JEWELRY. ≡



**M. L. READ & CO.,**

161 DORRANCE ST.,  
PROVIDENCE, R. I.

THE  
Old  
Reliable  
House

FOR  
STICK PINS AND  
WHITE STONE GOODS

**NEW CLOCK STAFF WRENCH.**



This entirely new and most useful tool is for setting up clocks, particularly fine and costly ones. Can remove pivots at ease. No chance of displacing other pivots in the operation. For description, send 5c. in stamps for catalogue of over one thousand varieties of fine tools.

O. W. BULLOCK & CO., Springfield, Mass.

WHITE'S EYE SHADE. **W. B. WHITE & SON**  
MANUFACTURERS OF



Spectacle and Eye Glass  
CASES

90 SOUTH STREET, BOSTON.

Special Cases made to order for Optical Trade. Cases for Trial Lenses. Opera Glasses recovered, etc. Chatelaine Spectacle Cases, Metal Bound Leather Cases for combs, scissors, etc. Over forty kinds of cases manufactured.



THE *Pairpoint*

# MFG. COMPANY,

MAKERS AND DESIGNERS OF

## "HIGHEST GRADE"

# Gold & Silver Plate

o o o o

FACTORIES:

## New Bedford, Mass.

WE ALWAYS CARRY IN STOCK

A LARGE LINE OF

# RICH CUT GLASS

... AND ...

## Decorated Art Wares.

## Jobbers

You make no mistake in ordering a line of

### "PAIRPOINT"

## Hollow & Flat Ware



No. 4907. SMOKING SET, GOLD LINED.

SALESROOMS:

NEW YORK, - - - 20 Maiden Lane.  
CHICAGO, - - - 224 Wabash Ave.  
SAN FRANCISCO, - - - 220 Sutter St.



No. 944. EMBOSSED JEWEL BOX, SATIN LINED.



No. 2764. TOBACCO BOX.

**A. J. LOGAN,**  
MANUFACTURER OF  
WATCH TOOLS, HAIR SPRINGS AND  
**WATCH MATERIALS.**

◀ New Catalogue just issued, Sent on Application. ▶  
WALTHAM, MASS.

**CROUCH & FITZGERALD.**

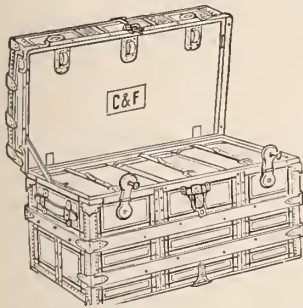

Jewelry Trunks  
and Cases,  
161  
Broadway,  
Bet. Cortlandt and  
Liberty Sts.,  
688 B'way,  
701 6th Ave.,  
NEW YORK.

**PATENTS SECURED WITHOUT  
FAIL OR DELAY.**

Send Rough Sketch or Model and I will tell you whether you can obtain a patent, WITHOUT CHARGE. Fifteen years' experience. Ample references. Address

**C. T. BELT,**  
WARDER BUILDING WASHINGTON D. C.

**2 MEDALS AWARDED**



AT  
WORLD'S  
FAIR,  
1893.

Providence Steel Works, Providence, R. I.  
Correspondence Invited.

## We sell to the legitimate Jewelry and Stationery trade only.



## CHOICE PAPERS

MAKERS OF

# FINE STATIONERY

For Correspondence, Wedding and Business Use, handsomely boxed, specially suited to the Jewelry Trade.

18 MURRAY STREET, NEW YORK.



# R. WALLACE & SONS MFG. CO.

SILVERSMITHS

Trade Mark.



R. W. & S.  
Sterling.

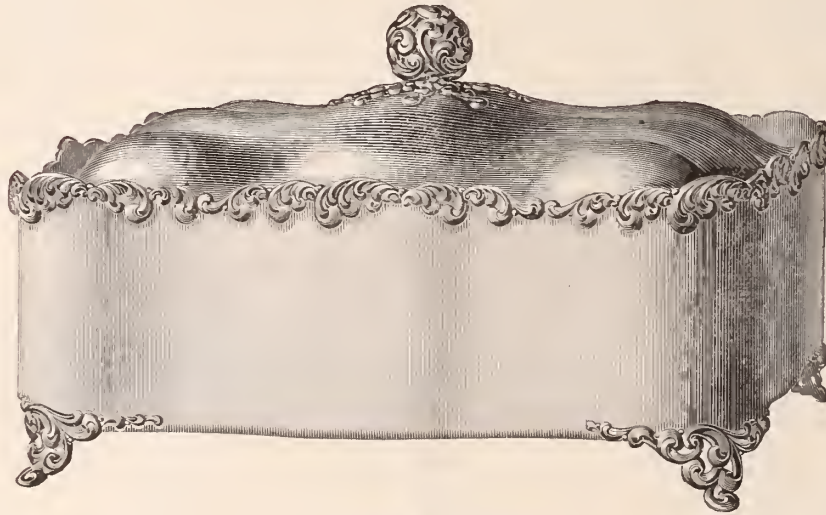

WAVERLEY SARDINE BOX.

Manufactories and  
Main Office,

WALLINGFORD, - - CONN.

BRANCHES :

NEW YORK  
3 PARK PLACE.

SAN FRANCISCO,  
120 SUTTER STREET.

CHICAGO  
86 WABASH AVENUE.



It is believed they took to the mountains and are in hiding near Richmond.

The men were arrested for robbing George W. Simonton's jewelry store, in Washington, of several hundred dollars worth of jewelry, which, it is believed, they hid away in the Orange mountains, near Newark. The men were arrested in Newark and brought here and would have been tried at the April term.

**The Dominion Increases the Duty on Jewelry.**

OTTAWA, Ont., March 28.—In the Dominion House of Commons yesterday afternoon, G. E. Foster, Minister of Finance, commenced the delivery of the budget speech. The keenest interest was manifested, as important tariff changes were expected. In speaking of the tariff, Mr. Foster said that in Canada the protective tariff had never been burdensome to the mass of consumers or unjust to any large class.

Referring to the proposed revision of the tariff he said that the government would stand fairly and squarely upon the principle of protection. The degree of protection they proposed to regulate by the probable benefit to Canada, but the principle they would not swerve from. The Government did not expect this year nor next, he said, to have any considerable surplus. They knew they would have to exercise strict economy, and this was a factor in the rearrangement of the tariff. They had not attempted, accordingly, any uniform or horizontal reduction in the tariff. They had simply gone in the true National policy plan of a practical adaptation of the tariff to the Dominion's needs. Neither had the Government followed the rule of ad valorem duties to the exclusion of specific duties, or vice versa, as they considered there were arguments in favor of both.

Among the changes, the duty on manufactures of gold and silver and jewelry are raised from 20 per cent. to 25 per cent.

**Michayell Waltaiger Now Has Plenty of Time.**

FALL RIVER, Mass., March 29.—Several people of this city would like very much to know what has become of Michayell Waltaiger, who has been engaged in the repairing of jewelry during the past Winter, at 22 7th St. About two weeks ago he suddenly disappeared, taking with him several watches which had been left with him to be repaired. He took his entire stock on leaving and many doubt if he ever intends to return.

It is estimated that the jeweler has between \$200 and \$300 worth of local timepieces in his possession, and it looks very much as though he would keep them.

# THE BOWDEN SEAMLESS RING

IS MADE ONLY BY

## J. B. BOWDEN & Co.,

Makers of Finger Rings of every Description.

### COR. BROADWAY & JOHN STREET,

NEW YORK.



W. H. SCHWARTZ & CO.  
MANUFACTURERS OF FINE  
**JEWELRY**  
AND  
NOVELTIES  
IN GOLD AND SILVER.  
355 Mulberry Street.  
Newark, N.J.

**WM. SCHWARZWAELDER & CO.,**  
Fulton St., cor. Pearl, - NEW YORK

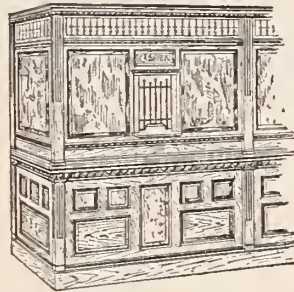

MANUFACTURERS OF  
**DESKS, CHAIRS, Etc.**  
Jewelers' Cases and Counters, Office Partitions, Rails, Etc.

Special Designs, Plans, Prices, etc. upon application.

## LEGENDS OF GEMS.

BY FRANK SHELLEY.

Gilt edged; bound in leather; a perfect specimen of the printer's and binder's art. Should be in every jeweler's library. Price, \$1.00. For sale by

THE JEWELERS' CIRCULAR PUB. CO.



SPECIALTY: SALES OF  
**JEWELRY, BRIC-À-BRAC**  
AND  
ARTICLES OF VERTU

**ALBERT BERGER & CO**  
47 MAIDEN LANE, N. Y.  
**Spectacles & Optical Goods,**  
GROUND LENSES A SPECIALTY.



## Prices of LATHES AND CHUCKS are "WAY DOWN"

All purchasers of our THREE FOUR lathes and chuck combinations now receive FREE our new TIP OVER "T" REST, on which we have patent pending. The most valuable addition to plain lathe in recent years.

SEND FOR FEB. PRICE LIST.

WALTHAM WATCH TOOL CO., SPRINGFIELD, MASS





## Sarah Bernhardt's Jeweled Costumes.

THE JEWELLED COSTUME OF SARAH BERNHARDT AS IZEYL—SEÑORITA OTERO'S MODEST DISPLAY OF JEWELS—VICTOR CHAMPIER ON THE INDUSTRIAL ARTS OF THE UNITED STATES.

PARIS, France, March 23.—One of Sarah Bernhardt's costumes in her new part, Izeyl, deserves special description. She wears, in the first act, a kind of blouse of silk worked with gold and silver wire and adorned with opals in cabochon, a *corselet* embroidered with Indian turquoises, a loose neck chain formed of opals and turquoises, and a jeweled girdle, from which hang two double chains, falling at each side of the skirt, and holding an anulet of gold adorned with Oriental motifs, formed of precious stones incrustated in the metal. She also uses a full blown blue lotus in front of her corsage, and sprigs of blue lindweeds with Indian ornaments of jeweled gold, on her hair. Our illustration gives a sufficient idea of this pretty costume.

Señorita Otero, the well-known singer and dancer, has just returned to Paris from a fruitful *tournee* round the world. She appeared a few nights ago at the *Folies-Bergère* adorned with the large quantity of jewelry which she has received from wealthy admirers. She wore a magnificent diamond necklace of two rows, besides the famous pearl necklace of four rows, sold for 500,000 francs at the Léonide Leblanc sale mentioned in *THE CIRCULAR* about a year ago. She wore a brocade dress, the low necked bodice of which was bordered at the top with six large cabochon rubies divided with brilliants. Her fingers were adorned with dazzling rings, and her arms encircled with eight bracelets consisting of rubies, sapphires, emeralds and diamonds. She also wore a diadem formed of brilliants, and at her ears sparkled solitaires reported to weigh nearly 50 karats. The jewelry she carried on her person is believed to be worth about 1,500,000 francs.

Victor Champier some days ago delivered in the grand amphitheatre at the *Conservatoire des Arts et Métiers*, a lecture accompanied with views, on the industrial arts in the United States. He bestowed so much time

on architecture chiefly of the Sullivan style, that he could but passingly mention, although with high praise, the progress realized by American manufacturers in the jewelry and silver lines, as shown by works produced by Tiffany & Co., the Gorham Mfg. Co., and the Whiting Mfg. Co. In the plated ware line, Victor Champier pointed

fany's new departures in the line of decorated glass.

An original flower vase is of glass, looking like rough vari-shaded green ice. Six bunches of sea weed of brown gold are applied slantingly, at regular intervals, on the body of the vase, in such a manner that it stands on the lower part of the bunches.

A curled, elongated leaf placed across each bunch at the base of the vase gives to the lower end of the bunches the appearance of a sword hilt. JASEUR.



BERNHARDT'S JEWELS IN HER NEW PART.

out the unparalleled quantity and the great variety of goods produced yearly by the Meriden Britannia Co. He also made very interesting remarks concerning Louis Tif-

listening to the application, Judge Lippincott took the papers and reserved his decision. The case aroused considerable interest.

## Taxes On The Old Marion Watch Factory.

JERSEY CITY, N. J., March 28.—Application was made by lawyer G. L. Record in the Supreme Court last week, before Judge Lippincott, for a mandamus against City Collector Patrick H. O'Neill. Several weeks ago the State board of commissioners of appeal reduced the valuation of the Marion watch factory from \$56,000 to \$30,000 for the three years last passed. When the company tendered the amount of taxes to the city collector he insisted upon receiving interest, which the company refused to pay, and instructed Mr. Record to commence proceedings to compel him to. After



TYROLEAN ALMOND SCOOP, No. 15.

We are continually producing new ideas in Sterling Silver Hollow Ware, Toilet Articles, Novelties, &c., as well as in Flatware.

## F. M. WHITING & CO.,

NORTH ATTLEBORO, MASS.

New York Office,  
857 BROADWAY

AFTER MAY 1ST,  
at 1128 BROADWAY  
and 208 FIFTH AVE.



Handsome New Catalogue Showing 22 Patterns in Teas, and 36 Patterns in Coffee Spoons, will be mailed on application.





OUR recent fire will not interfere with our meeting the tremendous demand for our

# Sterling Silver Belts

and filling orders promptly.

**\$1.25**  
COMPLETE.

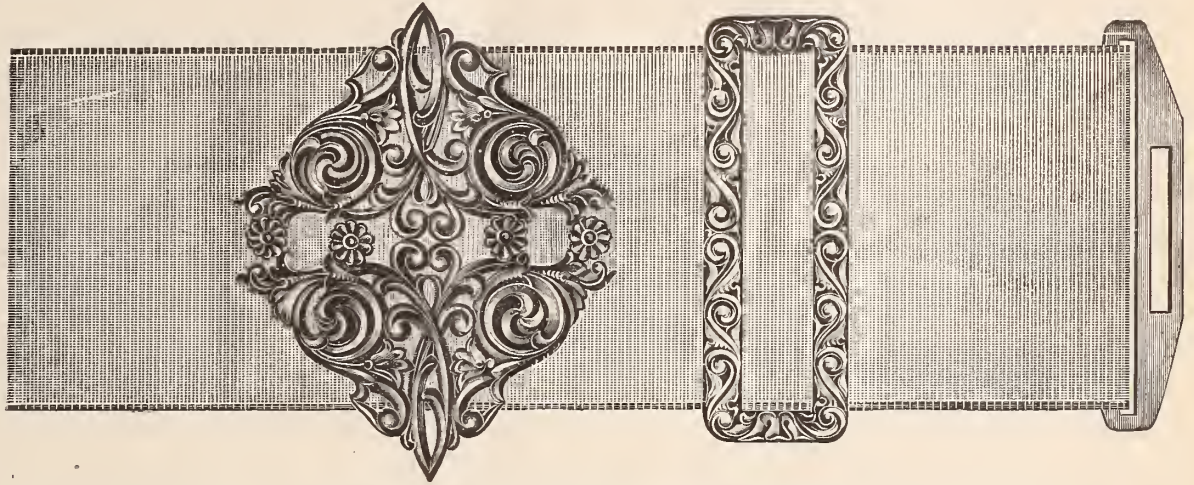

Absolutely Unrivalled in every Particular.

**\$1.50**  
COMPLETE.

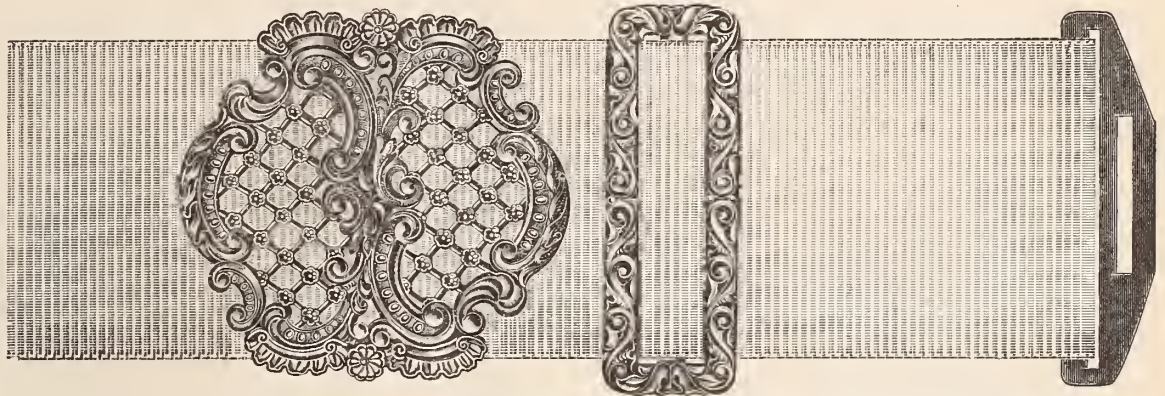

We give WEIGHT as well as quality, SKILLED Workmanship and Finish.

**\$1.90**  
COMPLETE.

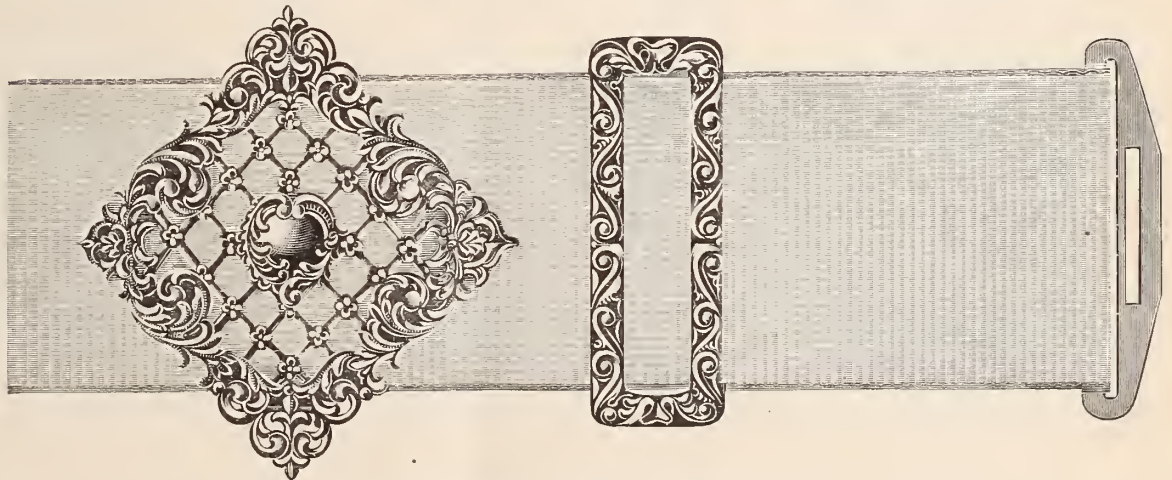

An endless variety of patterns.

## JOHN W. REDDALL & CO.,

No. 107 HAMILTON STREET,

NEWARK, NEW JERSEY.

Fourteen Karat Gold, and Sterling Silver Goods of Superior Make and Finish, at Salable Prices.



# ANNUAL LADIES' NIGHT BOSTON JEWELERS' CLUB

AT PARKER HOUSE, BOSTON, MASS., MARCH 27, 1894.

Boston, Mass., March 27.—This evening the crowning event of the club year for the Boston Jewelers' Club was observed at the Parker House, the occasion being their sixth annual ladies' night. Between 6.30 and 7.30 p. m., the time set for their assembling, the parlors placed at the disposal of the association gradually filled with guests and a brilliant group of charming ladies and gentlemen were engaged in animated conversation as the reception hour drew to close and the announcement was made that the banquet hall awaited their presence.

Covers were laid for 38 persons. Seated at the head table were president Charles F. Morrill, and Mrs. Morrill with Lieut. Thomas J. Olys, the president's guest, while at the right and left respectively were ex-president Charles Harwood and Mrs. Harwood and ex-president David C. Percival and Mrs. Percival. Around the long table that stretched down the room were the other participants as follows:

Mr. and Mrs. Austin T. Sylvester, Miss May Crawford, Mr. and Mrs. William H. N. Pratt, Mr. and Mrs. James S. Blake, Mr. and Mrs. Arthur H. Pray, Willard

The menu, which was handsomely printed on heavy bristol and held with a band of silk ribbon, bore on the title page in a raised circle the words: "Sixth Annual Ladies' Night, Boston Jewelers' Club, Parker House, March 27, 1894," and above the circle was the individual name in gold letters. Each lady's menu page had at the top a Victoria chain embossed and each gentleman's a Dickens chain.

After the menu's delights came the feast of wit and wisdom, without which no Boston banquet is considered complete. President Morrill's opening remarks were sealed with the approval of his appreciative auditors and touched a responsive chord in the listeners the table round. He said:

*Fellow Members and Guests of the Boston Jewelers' Club:*

Another year has rolled away, and again we meet together to enjoy our annual "ladies' night" banquet. To-night is ladies' night, and we are here to honor and do homage to our fair home partners.

We have with us distinguished guests—those distinguished in public life, and those not less distinguished to us—our wives and daughters, who charm our homes with their presence.

On behalf of the club, and for myself, I extend to you all a hearty greeting and welcome, and my foremost thought to-night is for the enjoyment and pleasure of those who are present on this occasion.

It is most appropriate at this time, on the night of our annual dinner, to congratulate ourselves on the high character of our organization. We have stood like beacon lights on the shores of our coast, exposed to the storm, but able to withstand the shock of wind and gales. Such times as these have shown the financial strength and character of the members of our organization.

There is no question but that men of honor and integrity have succumbed to the severe financial conditions of the past few months. Such men should have our sympathy. And the fault is not entirely their own but is largely due to the unsound business principles that have been so generally adopted throughout our country.

The extending of large credits, even where the contracting parties are deemed responsible, is unsound in principle, and in time is sure to lead to disaster. During the last few months the business men of this country have felt the full force of this great truth, and changes are being made in business relations to-day that were not thought of or contemplated one year ago.

Yet it is gratifying to know that, notwithstanding the general financial depression, the jewelry trade has well held its own, and may safely be classed side by side with the other great manufacturing interests of this country; and it is pleasant also to note that among the jewelry trade none have stood in higher repute than the jewelers of Boston.

Back of all this is the history of our State, our city and New England, showing from what sterling ancestry sprang the New England business men of to-day.

Many years ago a landing was made on our shores of noble men and women. From them sprang our grand commonwealth, our city of Boston, the Boston

Jewelers' Club and the sterling honor that governs among the jewelers of Boston. With a less noble origin we might have had a feeble commonwealth and a primitive Boston, without a jewelers' club and without a demand for the beautiful jewels of our trade which sparkle and glisten while breathing love to women and a honor to men. With the lovely and charming ladies that we see here to-night, wearing the beautiful jewels that are the emblem of our trade, in the fair city of Boston, protected by our grand commonwealth—what more can we expect until we have been transformed, like angels, which is the ultimate reward of all Boston jewelers.

The president next called upon secretary William H. N. Pratt, who read the letters of regret from H. F. Hahn, president of the National Association of Jobbers in American Watches, Royal E. Robbins, treasurer of the American Waltham Watch Co., and J. V. Kettell, of Kettell & Blake.

The first toast of the evening was then announced:

*"Massachusetts, our grand commonwealth, and her executive, our Governor."*

"We expected the Governor to be with us and respond to this toast, and we have but just learned that it will be impossible



CHARLES F. MORRILL,  
PRESIDENT.

Harwood, Miss E. M. Harwood, Mrs. R. F. Gaylord, Alvin T. Morrill, F. A. Singleton, Mr. and Mrs. Oakes A. Drinkwater, Mr. and Mrs. Marcell N. Smith, Mr. and Mrs. Henry W. Patterson, John B. Humphrey, Mrs. E. Humphrey Allen, Mr. and Mrs. Charles A. Gilchrist, Miss Carrie L. Gilchrist, Mr. and Mrs. Edward A. Bigelow, Mr. and Mrs. Fred. H. Pope, Miss H. Hobbs, and J. B. Scammon.



AUSTIN T. SYLVESTER,  
VICE-PRESIDENT.

for him to do so on account of pressing duties. However, we may all honor the sentiment by arising and pledging together our love for our grand commonwealth," said the president.

The Hub itself came in for a toasting next, her health being proposed as follows:

*"Our Home City, Boston: may her brilliant past promote a glorious future."*



To respond to this the vice-president of the organization, Austin T. Sylvester, was called upon as a "gentleman ever ready to respond when duty calls." Mr. Sylvester spoke enthusiastically of the business home of himself and his associates. Following is an abstract of his remarks:

*President and Ladies and Gentlemen:*

There is no record made which shows that Boston was ever discovered, but we do find that it was settled in 1630. Among its great attractions for settlers were its three hills, and if history correctly informs us a tradition was ever current that under one of these hills was a mine of baked beans, for which Boston was always noted.

The first newspaper in Boston was printed in 1690, and methinks if its editors could see modern newspaper row to-night they would think that the seed had fallen in good ground and brought forth much fruit. Of the many events which have occurred in our home city, probably none ever had more effect on our country than the Boston massacre on King St., in March, 1770. It was one of the events which led up to the war of the revolution.

The next historical event of any moment was the destruction of the tea in Boston harbor in 1773. The ladies will, at this late day, feel that their rights were invaded, although it was only another step towards freedom.

In 1775, when Paul Revere made his famous ride he little thought that he was awakening a new country—one that was to be a country for all nations to come to and enjoy that freedom which man always craves.

Boston was chartered in 1822 as a city, and from that time has carried herself with such dignity that she has become the hailing place from which all the citizens of the old Bay State in their wanderings claim to have sallied forth. The Boston of 1822 is not much like the fair city that we know, which has not only grown



ARTHUR H. PRAY.

within its natural limits, but has reached out after the smaller towns and cities by which it is or was surrounded, so that during her growth she has annexed Roxbury, Dorchester, Charlestown and Brighton. During all these years she has always been in the front in promoting the many interests which make the greater Boston. In education she has always stood in the front rank. Music has always had a home here, and from her borders some of the finest musicians of the world have gone forth.

Always ready in good works, she was among the first to send troops to the front during the great rebellion, and care for those who lost their health in defense of these United States.

The City of Boston before and after the great fire of 1872 is familiar to most of us, and as we look back and then forward we feel that such calamities are not unmixed with good. In closing I would ask you all to stand by our fair city in all her works of charity and love and let Boston be one of the finest cities in our country.

The toast to the fair sex came next. It

was short, but expressive, and read as follows:

*"Our Guests, the Ladies, may we ever adore them."*

The president's guest, Lieut. Thomas Jefferson Olys, second officer of the Ancient



W. H. N. PRATT,  
SECRETARY-TREASURER.

and Honorable Artillery Co., of this city, responded to the sentiment. His reference to the measures now before the Massachusetts Legislature in which so many women are interested, were forcible and evidently expressed the sentiments of many of his hearers. A brief outline of his remarks follows:

*Mr. President and Ladies and Gentlemen:*

I am glad to be here to-night and I wish to thank the club for complimenting me so highly as to ask me to respond to the toast to your guests. I look forward to the time when equal rights for both men and women will be recognized by the law, when for equal work women will receive the same wages as men and I am pleased to note the progress made toward woman suffrage.

No man worthy of the name is unwilling that woman should enjoy the rights that are hers by virtue of her intelligence and her capability and it is unfair and ridiculous that she should be looked upon as an inferior. I am glad that the lower branch of the State Legislature has acted the manly part by passing the municipal suffrage bill, granting the ballot to women in local elections, and I hope the Senate will do likewise. In that case I believe the Governor will sign the bill.

It is not true that woman's influence cannot be exerted in politics without detracting from her home influence. Rather may we expect it to enhance her position in the home as well as in the community.

Mrs. C. Humphrey Allen then favored the company with two charming vocal solos, "The Creole Love Song" and the Romeo and Juliet "Waltz Song," both of which were heartily applauded by her listeners. J. B. Scammon, who finds time, when he is not engraving designs for the trade, to appear in opera and concert as a member of one of Boston's well-known quartets, also sang two solos, "The Mighty Deep" and by request, "Rocked in the Cradle of the Deep."

*"Our members, past and present, may past recollections add joy to the present."*

This was the fourth toast, and to respond, the president gracefully introduced the former secretary of the club, James S.

Blake, who was warmly welcomed. In brief he said:

I thank you, Mr. President, and you, ladies and gentlemen, for the cordial and generous reception you have accorded me. I find it somewhat difficult to respond to this toast. There is no difficulty in speaking of the past members, as we remember only the good qualities of those who have left us, but the trouble comes when we endeavor to speak of those who are living, and most of whom are here this evening. I hasten to assure my brothers of the Jewelers' Club that, although I presume I know of their doings as well as it is possible for any perfectly innocent person to know, I shall make no personal mention here of late hours, convivial gatherings or general depravity, particularly when away from home.

I have deemed it best to make this announcement, as I understand that some of the gentlemen present, on hearing that I was to respond to the toast of the "past and present members," had expressed a fear that I might in an unguarded moment make mention of things that would necessitate embarrassing explanations. But I assure you, I will be very discreet. The Boston Jewelers' Club, speaking in a general way, is composed of members who are extremely fond of the good things of earth. There is no sluggish movement of blood in the members of this club. Their circulation is all right, and toning up of the system is not required. They are alert for anything desirable, whether it be a good time or a customer out of whom a good square profit can be made. They are the best of good fellows, fair and honorable competitors. This club has been the means of bringing us more closely together, and association with each other has dispelled the old-fashioned idea that our competitor is a bad man, and one who cannot be believed.

Why, Mr. President, I remember that when I started in this business, a boy in a country store, the largest part of our talk with a customer was to convince him that our neighbor across the way was wholly unreliable



JAMES S. BLAKE.

and that everything he said must be taken with a great deal of allowance, when the real truth was, he was a thoroughly honest man, and even a child could have traded with him with perfect safety for his word to say the least, was equally as good as our own. I might mention many instances where the club has been the means of promoting sociability, kindness and a generous fraternal feeling. What glorious and never-to-be-forgotten times we have had on our president's yachts, what generous hospitality he has dispensed, and how many headaches the next morning he is responsible for?

This club, according to the books that are kept so carefully by our able and esteemed secretary, has been in existence only six years, but during those years what good times we have had and how short the time appears! They remind me of the little mischievous colored boy who, being asked his age, said, "They tells me I'm 10 years old, but reckoning by the fun I've had I should tink I was a hundred." So it is with our club; young in years, but old in pleasure and gratifying results.

Tenderly and kindly we remember our past members. Their failings, if they had any, we have forgotten, their virtues we will emulate, their devotion to honor



and manhood we will cherish as priceless jewels, and when in time it comes our turn to join them in even a brighter world than this, may we have done some slight deed or said some kind word that will cause us to be remembered with tenderness and love.

Members of the Boston Jewelers' Club, in all seriousness I say we can and should make this club the means of doing much good in making us more charitable towards each other, more friendly and generous in dealing with the mistakes and errors that must unavoidably creep into our business lives, let us all take for our club motto the words of the immortal Lincoln, "With malice toward none, with charity for all."

At the close of Mr. Blake's remarks the president referred to the poem entitled "The Legend of the Jewels," written for the club and read by one of the guests of the organization a year ago. "This poem," said he, "was expressly adapted to our occasion and was thoroughly appreciated by us and printed in full by our trade journals. It was the theme of conversation and a source of delight for many months, and is the most beautiful and expressive poem ever written on the jewels of our trade. Tonight I take pleasure in presenting our guest once more and she has kindly consented to favor us again with a reading." Thus introduced, Miss May Crawford was accorded a hearty greeting and read some pleasing selections, much to the delight of her auditors.

The last toast was then announced:

"The Boston Jewelers: may their honorable record like the gems of our trade, continue ever brilliant and never, never fade."

"To respond to this toast," said President Morrill, "I take pleasure in introducing the first president of this club, the senior member of our trade; a gentleman we have held as the standard of integrity and honor and whose example we have striven to emulate—Mr. Charles Harwood." He said:

*Mr. President and Ladies and Gentlemen:*

I feel like thanking the president for calling upon me to respond to the last toast, for there is little left to say and little time in which to say it. I am here, however, to claim the credit of being one of the pioneer drummers in the trade, having come to Boston 49 years ago with a small case of optical goods to sell to the dealers in that line then doing business here. They were few in number. The three concerns that I found in town were in the habit of making their own gold and silver frames. They were the best in the world, too, at that time and footed up about 50 dozen in a year of the former material.

By way of contrast it may be interesting to note that the American Optical Co alone manufactures nowadays more than 100 dozen daily. Eyeglasses were not worn then, and rubber, zylonite and nickel frames were unknown to the trade. The changes since these earlier days among the jewelers in Boston have been many and frequent.

Fig. Iron Kelly, afterward known as the "father" of the national House of Representatives, was learning his trade then with G. A. Guild. He drifted away from Boston and became distinguished in politics. Mr. Guild still remains in our midst, vigorous and in active business. Later came the time when the Providence and Attleboro manufacturers established offices here. From some of these concerns sprang a number of prominent jobbing jewelry houses. They have branched out and sent offshoots into all parts of the country.

The trade in watch materials, the jobbing trade in watches and jewelry, the clock jobbing houses and the large and favorably known retail concerns that have

established themselves in the Hub have made the city the centre of the trade in this entire section, although 50 years ago the position that it has now attained in the jewelry world could never have been predicted for it.

Mr. Harwood's address was full of historical data and mentioned by name every firm of prominence doing business in this city during his long career. Covering, as it did, a period of nearly half a century, it was almost a complete epitome of the history of the modern jewelry trade of New England.

This closed the evening's program and the company shortly after dispersed, but not without mutual assurances that the latest dinner and ladies' night of the club had been one of the most successful since the formation of the organization.

#### Utah Jewelers Associate to Encourage Home Industries.

SALT LAKE CITY, Utah, March 30.—The jewelers of the city have organized what is to be known as the Jewelers' League of Utah. The object of the organization is to protect and encourage home industries. The following officers were elected: President, W. W. Hall; vice-president, A. Berg; secretary, J. H. Knickerbocker; treasurer, H. Reiser; watchman, N. Smith; conductor A. O. Claimer.

For some time past the manufacture of articles of jewelry, principally in the form of souvenirs, has been going on, and the sale of these articles has stimulated the trade to branch out in other lines.

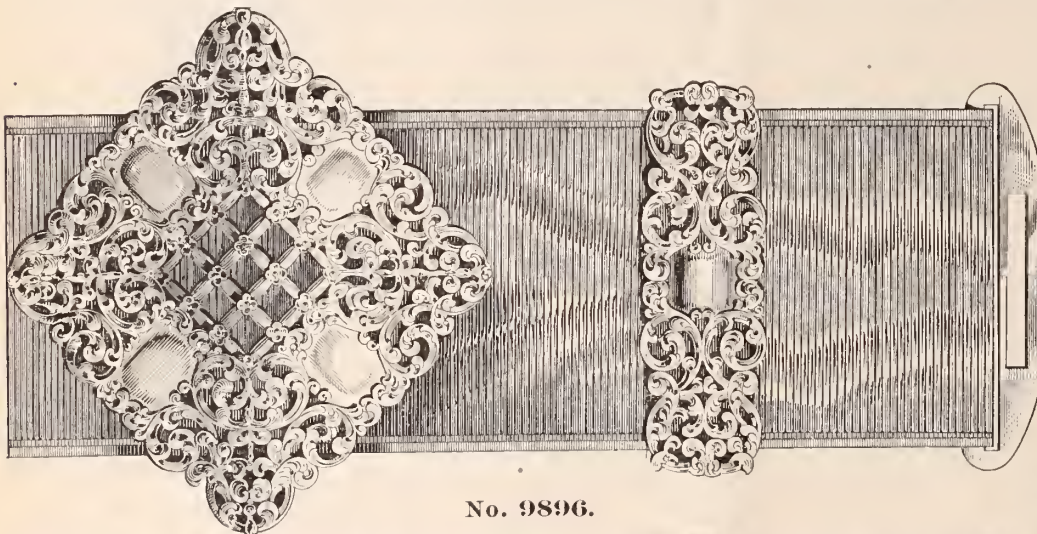

No. 9896.

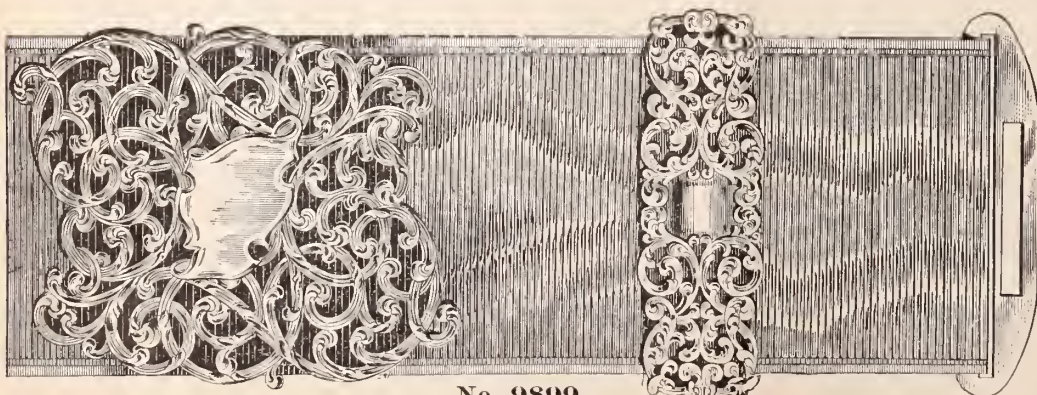

No. 9899.

## Sterling Silver Belts.

WE are pleased to announce that notwithstanding the enormous demand for the Moire Antique Belting, we are in a position to guarantee shipment of all orders the day following their receipt.

WE beg to acknowledge the request of our customers asking us to discontinue quoting prices on goods advertised in the Trade Journals. After this issue we will only quote prices when we deem it necessary to protect a pattern.

**UNGER BROS.,**  
192 BROADWAY,  
NEW YORK.



# The Jewelers' Circular

AND  
HOROLOGICAL REVIEW.

PUBLISHED EVERY WEDNESDAY BY

THE JEWELERS' CIRCULAR PUB'G CO.,

189 BROADWAY, NEW YORK CITY.

A JOURNAL DEVOTED TO THE INTERESTS OF JEWELERS, WATCHMAKERS, SILVERSMITHS, ELECTRO-PLATE MANUFACTURERS, AND ALL ENGAGED IN KINDRED BRANCHES OF INDUSTRY.

Our Editorial columns will contain our own opinions only, and we shall present in other columns only what we consider of interest or value to our readers. Advertising matter will not be printed as news.

Advertising rates in THE CIRCULAR are lower, considering the number of tradesmen reached by its large circulation, than in any other jewelry journal.

Notices of changes in standing advertisements must be received one week in advance; new matter can be received up to Monday.

## INFORMATION FOR SUBSCRIBERS.

### Terms of Subscription, Postage Prepaid.

	PER ANNUM
United States and Canada, . . . . .	\$2.00
Foreign Countries in Postal Union, . . . . .	4.00
Single Copies, . . . . .	.10

New subscribers can commence at any time.

Payments for THE CIRCULAR, when sent by mail, should be made in a Post-Office Money Order, Bank Check or Draft, or an Express Money Order or Registered Letter. All postmasters are required to register letters whenever requested to do so.

Pay money only to authorized collectors having proper credentials.

Returning your paper will not enable us to discontinue it, as we cannot find your name on our books unless your address is given.

In changing address always give the old as well as new one. Your name cannot be found on our books unless this is done.

We will continue to send papers until there is a specific order to stop, in connection with which all arrearages must be paid; but such an order can be given at any time, to take effect at the expiration of the subscription. All such orders will be promptly acknowledged by mail.

The Courts have decided that all subscribers to journals a responsible until arrearages are paid in full and an order to discontinue has been received by the publisher.

Member of the American Trade Press Association.

VOL. XXVIII. April 4, 1894. No. 9.

## Our Spanish-American Edition.

WE publish this week the Spanish-American edition of THE JEWELERS' CIRCULAR, which has been in preparation during the past month. As the issue evidences, the enterprise has been accorded liberal encouragement, so greatly so that the management of THE CIRCULAR has decided to publish a Spanish-American edition of this journal quarterly; and we have received many assurances from reliable and unprejudiced sources that the undertaking will prove advantageous to those firms who utilize the pages of the edition to bring their productions prominently to the notice of southern foreign trade. In exploiting this edition, we have deemed it advisable to assure its recipients of the reliability of THE JEWELERS' CIRCULAR and its advertising patrons, which we have done in the following terms, but in the Spanish language:

WE GREET YOU.

We take it for granted that THE JEWELERS' CIRCULAR has heretofore been unknown to

many of the jewelers who are the recipients of this impression; but it is our purpose to endeavor to acquire a closer relationship with our southern fellow-Americans, and at the same time bring before their attention the sterling characteristics of the products in the lines of jewelry, watches, clocks, silverware, silver plated ware, optical goods, etc., of reputable and progressive firms in the United States.

It is but proper here, in making our bow to our Southern confrères, to convey to them a brief account of THE JEWELERS' CIRCULAR, its position in the field of journalism and the esteem in which it is held by the jewelry trade of the United States. THE JEWELERS' CIRCULAR on Feb. 1, 1894, celebrated its 25th birthday, it being, therefore, one of the oldest industrial journals in the country. From an initial issue of eight pages it steadily increased in size until its influence and importance warranted editions ranging from 120 to 150 pages. Up to Feb. 1, 1891, THE JEWELERS' CIRCULAR was published monthly; but at that time the demands of the industry that the journal represents urged the publishers to issue the paper every week, each number to contain 48 pages upward, or about 200 pages a month.

During this long period of 25 years, THE JEWELERS' CIRCULAR AND HOROLOGICAL REVIEW has acquired the reputation of being the highest class technical and commercial journal in the jewelry and cognate trades. This statement is attested by the paper's extensive paid subscribers' list, numbering in the thousands, the liberal advertising patronage it acquires, and the numerous compliments the press and people constantly pay it in writing and in speech. Being the oldest journal in the trade by many years, and being conducted on the most progressive though conservative plan, its undertakings have always received the applause and support of the trade. Dealing only with the most responsible firms, as we believe only responsible and legitimate manufacturers should have the trade of the retailers, we earnestly assure the reader that his dealings with the firms advertising in this Spanish-American edition will prove greatly to his advantage. These houses are successful, because they are progressive; they manufacture the goods the public wants, and sell them at a small margin of profit, popularity of goods and consequent large sales being their principle of business.

This edition is in general appearance a counterpart of the regular English edition of THE JEWELERS' CIRCULAR. We publish a journal possessing many artistic attributes, because we deem the character of the jewelry trade amply warrants it.

THE JEWELERS' CIRCULAR PUB. CO.

### Packing for Export.

MANUFACTURERS and exporters desiring to extend their foreign trade should profit by the hints and advice given by United States Consuls in reference to the better packing of

goods shipped from our ports. The complaints do not refer so particularly to the imperfect packing, as they do to the method of sending goods in such shape as to make packages and cases undesirable bulk on certain routes and over certain territory. The English, German and Continental shippers are, as a rule, careful in these matters and there should be corresponding care on the part of the shippers of the United States. Bad packing oft-times loses trade, and while the whims and exactions of some foreign receivers may be irritating, they should nevertheless be met. To obtain foreign trade we must conform to those customs which, however ancient and old fashioned they may appear, are what the people in partially developed sections understand to be the best for themselves.

THE custom, still too prevalent among small dealers, of leaving articles of value exposed in show windows over night, is strongly to be discouraged. The large number of petty burglaries and window smashings that constantly occur should arouse jewelers to a sense of danger. It is better to remove the cause than waste regret over lost goods.

### The Week in Brief.

THE Canadian Government made several changes in its tariff schedules—The principal creditors of F. I. Essig, Chicago, were made known—The annual meeting of the Rockford Watch Co. was held—The Warner Silver Mfg. Co., Chicago, incorporated—The West Coast Jewelry Co., San Francisco, Cal., filed a petition in insolvency—The schedules of Andrew & Doty, New York, were filed—Harry Laire and Charles Dorsey, charged with robbing Simonton's store, Washington, N. J., escaped from jail—Michayell Walthaiger, Fall River, Mass., is missing with a quantity of watches—The death occurred of Edgar Olmstead Bulkeley, with Tiffany & Co., New York—The store of T. V. Dickinson, Buffalo, N. Y., was taken possession of by the sheriff—The Sixth Annual Ladies' Night of the Boston Jewelers' Club, was held at the Parker House, Boston, Mass.—Two lawyers were arrested on the complaint of David Keller, of Keller, Ettlinger & Fink, New York—The death occurred of R. N. Peterson, New York—The annual meeting of the American Waltham Watch Co. was held—A decision was rendered in the suit of the Newark Watch Case Material Co., Newark, N. J., against the Wilmot & Hobbs Mfg. Co., Bridgeport, Conn.—Julius A. Lebkuecher was nominated for Mayor by the Republicans of Newark, N. J.—A meeting of the creditors of W. A. Graham & Co., Marlboro, Mass., was held in Boston, Mass.—E. W. Blue, Atlanta, Ga., gave heavy mortgages—A meeting of the creditors of J. R. Feeley & Co., Providence, R. I., was held—The application of Charles Jacques for a receiver for the Charles Jacques Clock Co., New York, was dismissed.



**New York Notes.**

E. L. Anrich has entered a judgment for \$155 against Robert Fullerton.

Joseph Alexander, retail jeweler, will give up his store at 1189 Broadway, May 1st.

A. Chalumeau, Thursday entered a judgment for \$3,019.73 against Jos. T. Ladd.

Mrs. T. Lynch contemplates giving up her uptown branch at 1123 Broadway, May 1st.

Alfred J. Minner, 113 Eighth Ave., made an assignment Monday to Michael T. Carroll.

David Brown, 75 Nassau St., has renewed a chattel mortgage on machinery for \$1,600 to L. Weil & Co.

Leon J. Glaenger, and Theodore Haviland were on *La Touraine*, which sailed for Europe Saturday.

A judgment against Eldin B. Hayden for \$273.87 has been entered in favor of H. B. and R. H. Duryea.

Max Freund, of Max Freund & Co., sails to-day on the *Teutonic*, for a six weeks' business trip through Europe.

H. Muhr's Sons have entered a judgment for \$2,273.33 against Julia Hess and another for \$2,013.39 against Ludwig Hess.

A judgment for costs amounting to \$105.88 has been entered against John Mason, in favor of his sister, Edith M. Faxon.

Irwin & Co., manufacturers of cane heads, removed Saturday from 79 Duane St., to more spacious quarters at 6 Howard St.

E. Bloom, manufacturer of envelopes for diamonds and precious stones, removed Monday from 169 Broadway to 35 Maiden Lane.

The Leroy W. Fairchild Co. will, May 1st, remove their New York office from 189 Broadway, to the Stevens building, 3 Maiden Lane.

The bond for \$5,000 of Wm. C. Beecher, the receiver of the property of Morris Ginsburg, was approved by Judge McAdam, of the Superior Court Friday.

L. Black & Co., wholesale opticians, have removed their office from 178 Broadway to Detroit, Mich., where their factory has been situated for the past 30 years.

Among the passengers on the *Etruria* which sailed for Europe Saturday were J. F. Fradley, of J. F. Fradley & Co., and J. A. Thierry, of Wm. B. Kerr & Co., New York.

William H. Heathcote, retail jeweler, who for the past 33 years has been located in the vicinity of Beekman St. and Park Row, has moved his store from 40 Park Row to 679 Broadway.

The suit in the Supreme Court brought by S. F. Myers & Co. against Ludwig and Julia Hess, to recover \$8,568.44 on a promissory note, has been put on the calendar for short causes for trial on April 6th.

Arrangements have been made by the Jno. A. Riley & Sloan Co., 860 Broadway, with James M. Bennett, by which he be-

comes manager of the company's office. Mr. Bennett assumed charge Monday. He will later be elected vice-president of the concern.

John K. Van Arsdale, a bookkeeper in the Chatham National Bank, who was well-known to many in the jewelry district, died at his home in Plainfield, N. J., Monday, March 26th, of typhoid pneumonia. Mr. Van Arsdale had been with the Chatham National Bank for nearly 20 years.

The sheriff Monday received an attachment for \$2,700 against Van Houten Bros. Jewelry Co., Newark, N. J., in favor of Otto H. Jossen. Van Houten Bros. sold out their business to the company about two weeks ago. The sheriff levied on a sample case of jewelry in the hands of an agent in this city.

Albro, Eaton & Co., composed of S. W. Albro, E. B. Eaton and E. A. Smith, dissolved April 1st by mutual consent, Mr. Albro and Mr. Eaton retiring. Mr. Smith continues the business. The firm manufactured gold plated chains and seals, in Providence, R. I. and had a New York office, at 176 Broadway.

Geo. B. Beiderhase, formerly of the firm of Fuchs & Beiderhase, is now vice-president of the Alvin Mfg. Co. Mr. Beiderhase will represent the company in New York, and the western cities. The Alvin Mfg. Co. have now in process of manufacture a line of hollow ware in new and original designs especially adapted to the best class of jewelry trade.

The Seth Thomas Clock Co., 49 Maiden Lane, have completed a clock for the tower of the United States Government building in Troy, N. Y. The dials three in number are seven feet in diameter and have gilt hands and numerals. The company also are putting in a similar clock with six foot dials in the United States Government building, in Dallas, Tex.

The two attachments obtained by Horace Craighead, against the Craighead & Kintz Mfg. Co., March 3rd and 6th, were discharged by Judge O'Brien, of the Supreme Court, Thursday, the defendants in the action appearing and giving sufficient security for the amount at issue. Horace Craighead obtained another attachment Friday against the Craighead & Kintz Co. for \$4,155.10.

The Individual Jewelers' bowling contest resulted as follows Monday evening:

Sacks.....	176	Thornbury.....	130
" .....	144	" .....	126
Hovet.....	154	Townley.....	157
" .....	137	" .....	163
Ruefer.....	143	Thornbury.....	149
" .....	136	" .....	120
Woodward.....	160	Sacks .....	190
" .....	245	" .....	138
Shiman.....	178	Thornbury.....	155
" .....	165	" .....	115
Sacks.....	143	Ruefer.....	173
" .....	139	" .....	167
Woodward.....	143	Thornbury.....	148
" .....	174	" .....	166

The games so far held have resulted as follows:

	WON	LOST		WON	LOST
Ruefer.....	10	8	Roll.....	13	5
Clifford.....	5	7	Sacks.....	8	8
Shiman.....	14	4	Thornbury.....	5	11
Thompson.....	2	10	Woodward.....	10	6
Mangold.....	5	9	Woodland.....	8	10
Hovet.....	10	10	Townley.....	8	10

The application for the appointment of a receiver for the Chas. Jacques Clock Co., 22 Cortlandt St., made by Chas. Jacques, its former president, on the ground that the company was insolvent, was argued before Chancellor McGill, in Jersey City, Monday. The application was dismissed with costs.

**Meeting of J. R. Feeley's Creditors.**

PROVIDENCE, R. I., March 31.—A meeting of the creditors of James R. Feeley, who recently assigned to George L. Vose, was held at Mr. Feeley's office to-day. There were 16 interested concerns represented. William H. Wade was chosen chairman and Marcus W. Morton, secretary of the Manufacturing Jewelers' Board of Trade, was elected secretary.

Mr. Vose read his report which showed that the nominal assets amounted to \$14,653.93; appraised assets, \$5,822.85. The nominal liabilities amount to \$13,604.83, of which amount \$1,667.16 are contingent, on account of indorsements on trade paper and \$868.51 are considered absolute liabilities and \$798.65 are not yet heard from. Mr. Feeley has personal assets, consisting mostly of real estate, amounting to \$3,249. This property, however, is mortgaged for \$3,176.56.

Of the nominal liabilities the claim of William De Wolf, Pittsburgh, Pa., for \$3,527, was presented at to-day's meeting but was disallowed. The claim was for \$3,000 in notes on which there was \$527 accrued interest. Counsel McGuinness, attorney for the High Street Bank, called attention to the fact that Mr. De Wolf was a co-partner with Mr. Feeley. Mr. De Wolf did not remember ever forming such a partnership, whereupon Mr. Feeley produced the articles of agreement, after which Mr. De Wolf acknowledged their validity and waived his claim to a portion of the assets of the concern. On the appraised assets of \$5,822.85 probably not more than \$2,500 could be realized at a forced sale.

Nearly all of the creditors of the firm are in this city, among the largest being: High Street Bank, \$4,600; John Austin & Sons, \$449.02; W. S. Hough, Jr. & Co., \$321; J. F. Quinn, \$250; Standard Seamless Wire Co., \$240; William Grosvenor's estate (rent) \$229.03; and other amounts from \$200 down.

Upon the suggestion of lawyer McGuinness, a committee of three, consisting of William H. Wade, Edwin D. McGuinness and John Austin was appointed to investigate the exact standing of Mr. De Wolf in Mr. Feeley's business. It is thought that the creditors will receive about 20 cents on the dollar.



**L. TANNENBAUM & CO.,**  
**Importers and Cutters of DIAMONDS AND PRECIOUS STONES,**  
**COR. MAIDEN LANE & NASSAU ST., NEW YORK.**

Telephone, Long Distance, 1959 Cortlandt.

25 HATTON GARDEN, LONDON.

**IN ORDER TO REDUCE OUR ENORMOUS STOCK WE OFFER THIS WEEK AT SPECIAL PRICES, THE FOLLOWING GOODS:**

Rough Siam Rubies for cutting purposes, at 50c. per karat.  
 Rough Fancy Sapphires for cutting, at 25c. per karat.  
 Rough Sapphires for mechanical use, and precious stones for collections, at \$2.50 per ounce.

**BRILLIANTS.**

1	Fine Brilliant, absol'y perfect, 7¼-1-16 kt.,	\$150.00	per kt.
1	" " " " 8¼ kt.,	90.00	"
1	" " " " By water, 10⅞ 1-32 kt.,	35.00	"
1	Flat " for Photo., 3½ 1-64 kt.,	140.00	for the stone
1	pair fine " 7½ kt.,	95.00	per kt.
1.33	1 very fine green bril., very scarce, 5 53-64 kt.,	350.00	"
2.33	1 " " brown brilliant, 4 22-64 kt.,	250.00	"
3.35	1 " " " " 2⅝ kt.,	125.00	"
1.16	1 " " fancy " 2⅝ kt.,	125.00	"
3.16	1 " " " " 2 11-64 kt.,	150.00	"
11.16	1 " " " " 1¾ 1-16 kt.,	100.00	"
12.16	1 Brilliant (Canary) for scarf pin, 2⅝ 1-16 kt.,	125.00	for the stone
13.16	1 " (White) " " 1¼ 1-16 kt.,	65.00	"
14.16	1 " (Canary) " " ⅝ 1-16 kt.,	35.00	"
24	Fine Meln, 59½ kt.,	32.00	per kt.
25	Cheap " 23 less 6-64 kt.,	10.00	"
27	Fine " 57 kt.,	41.00	"
28	" " 14¾ kt.,	36.00	"
29	" " 43¼ kt.,	40.00	"
135	28 Br.lliants (fine color), 14 less 1-16 kt.,	45.00	"
129	Fine Small Meln, 55 1-64 kt.,	38.00	"
110	19 Brilliants, 35 less 1-64 kt.,	70.00	"

**RUBIES.**

2.373	1 Fine Oriental Ruby, 3 less 4-64 kt.,	\$150.00	per kt.
33.348	1 " " " 1 less 1-64 kt.,	125.00	"

7.366	1 Fine Oriental Ruby, Spread, ⅞ 3-64 kt.,	\$200.00	for the stone
7.366	1 " " " ⅝ 1-32 kt.,	125.00	"

**SAPPHIRES.**

15,367	5 Fine Sapphires (extra quality), 6 1-32 kt.	\$50.00	per kt.
22,585	2 " " 2 9-64 kt.,	25.00	"
27,580	1 Extra " (a gem), 4 17-64 kt.,	125.00	"
12,367	1 " " (drop shape), 1 51-64 kt.,	90.00	"
12,606	1 " " 3 35-64 kt.,	65.00	"
32.52	1 " " 3 47-64 kt.,	40.00	"
6,396	1 Pink " 3 52-64 kt.,	10.00	"
2,445	80 Fancy " (all colors), 53 12-64 kt.,	5.00	"
11,408	12 Green " (very fine), 11 6-64 kt.,	15.00	"

**OLIVINES.**

10.385	107 Fine Small Olivines, 25¾ 1-32 kt.,	\$20.00	per kt.
9.385	" " " 24 less 1-16 kt.,	22.00	"

**OPALS.**

2,412	117 Fine Opals (round), 14 49-64 kt.,	\$12.00	per kt.
-------	---------------------------------------	---------	---------

**CATSEYES.**

18,244	21 Catseyes, 18⅜ kt.,	\$12.00	per kt.
14,349	21 " 7⅞ kt.,	15.00	"

**PEARLS.**

2,100	9 Pearls, 78¾ grains,	\$2.50	per gr.
2,564	9 " 37½ " "	2.50	"
9.94	1 " 10⅞ " "	11.00	"
32.92	1 " 10½ 1-16 grains,	4.00	"
E-16 97	1 " 11¼ grains,	7.00	"
6.95	74 String Pearls, 223¼ grains,	1.50	"
3,577	270 " 428 " "	1.00	"
1,570	10 " 47⅞ " "	3.00	"
9,563	3 " 26¾ " "	5.00	"
2,571	2 " 36 1-16 " "	7.00	"

**ROGERS, SMITH & Co.**

UNION SQUARE,  
 NEW YORK.



MERIDEN,  
 CONN.

**GOLD AND SILVER PLATE.**



### Death of Richard N. Peterson.

A prominent figure in the jewelry trade passed away with the death of Richard N. Peterson, which occurred at Roosevelt Hospital, 58th St. and 9th Ave., New York, Sunday night. Mr. Peterson had been failing in health for the past year and a half. Thursday last it was found that his sickness was of such a nature that an operation was deemed necessary, owing to a stoppage of the digestive tract. He was then removed to Roosevelt Hospital and an operation was



THE LATE RICHARD N. PETERSON.

performed by Doctors McBurney and Weir. This, however, proved unavailing, as peritonitis set in, which resulted in his death.

Mr. Peterson was one of the oldest and best known men in the wholesale jewelry district of New York city, having been a partner in one of the leading manufacturing jewelry firms of the country, Baldwin, Sexton & Peterson. New York was Mr. Peterson's home throughout his life. He was born here July 12, 1830, and received his education in the public schools. When about 16 years old he entered the employ of Baldwin & Sexton, Reade St., in the factory. After remaining long enough to master the details of the mechanical branch of the business, he was transferred to the office of the firm, and later, becoming more proficient, was made salesman. In this position he remained until about 1861, when he was admitted as a partner in the concern, the firm name being changed to Baldwin, Sexton & Co., and a few years later to Baldwin, Sexton & Peterson.

He was then managing partner until the dissolution of that firm in 1884. He then, in February of that year, started in business alone as a dealer in diamonds and precious stones, at 692 Broadway, and the next year took as a partner, Geo. W. Royce, who had been for years employed by Baldwin, Sexton & Peterson, as bookkeeper. Peterson & Royce established themselves at 189 Broadway, and became one of the prominent diamond firms of New York. January 6, 1890, Mr.

Royce died and Mr. Peterson wound up the business. From that time Mr. Peterson's active connection with the jewelry trade ceased. For the past two years he had an office in the Hays Building, 21 Maiden Lane.

Mr. Peterson was a man of strong personality and was universally respected in both business and social circles, in which he was a prominent figure. He was one of the founders of the New York Jewelers' Association and one of the oldest members connected with the Jewelers' Protective Union. He was an old member of the Union League Club, and was a pew holder at St. Thomas' Church. He was also a director in the Crocker & Wheeler Electric Co., 39 Cortlandt St., of which Schuyler S. Wheeler, who married his only daughter, is president. He was besides a director in the Jewelers' Circular Publishing Co., since the death of D. H. Hopkinson, in 1884.

The deceased leaves a widow and one child, Mrs. S. S. Wheeler. The funeral services take place this morning at 10.30 o'clock from St. Thomas' Church, 5th Ave. and 53d St., New York.

### A Pretty Bad Young Man, if All is True.

William A. Davidson, 19 years old, a former employe of Hipp Didisheim & Bro., watch importers, 83 Nassau St., New York, was arrested in Poughkeepsie, March 27th, on complaint of Wells & Zimmerman, jewelers, who charged him with grand larceny.

Last December, it is claimed, just after Davidson had made a call on the firm, who were customers of Didisheim & Bro., Howard Wells missed a diamond stud worth \$100. Simultaneously with another visit in February he missed a pin valued at \$25. Suspicion fell on Davidson, and when Mr. Wells received a letter from him stating that he was out of employment and would like a position he consulted Chief of Police McCabe, who advised him to telegraph him to come and Davidson arrived on March 27th. Mr. Wells stepped out a few minutes and in his absence Davidson filled his pockets with jewelry. Officer James McDonald watched him through a hole in a partition and put him under arrest. His pockets were filled with watches and jewelry and a number of pawn tickets for property worth \$600 were also found in his clothing. He was held for trial in \$2,000 bail.

Mr. Didisheim, Davidson's former employer, stated to a CIRCULAR reporter Friday that Davidson had been with the firm between four and five years until a few weeks ago. Since his arrest they have discovered that he robbed them of over \$1,000 worth of goods and perhaps much more than this amount. Pawn tickets for over that sum were recovered. Mr. Didisheim said that should Davidson be released on the Poughkeepsie charge he will be re-arrested on a warrant procured by his firm.

Nathan B. Barton and Englehardt C. Ostby, of the Ostby & Barton Co., and their wives, have returned from a pleasure trip to Florida.

### Last Week's Arrivals.

**THE CIRCULAR** has perfected arrangements for obtaining the names and hotel addresses of all the latest buyers visiting New York, and each day posts in its office, 189 Broadway, a bulletin which every member of the trade is cordially invited to copy.

The following out-of-town dealers were registered in New York during the past week: M. King, Boston, Mass., Holland H.; J. R. Burt, Detroit, Mich., Gilsey H.; Mrs. J. C. Nourse, buyer for Woodward & Lathrop, Washington, D. C., St. Denis H.; J. E. Ladd, Bristol, Conn., Astor H.; H. M. Allan, Montreal, Que., Holland H.; M. Stern, Philadelphia, Pa., Metropolitan H.; R. Long, Boston, Mass., Murray Hill H.; H. Kohn, Hartford, Conn., Astor H.; L. Kaufman, Pittsburgh, Pa., Hoffman H.; E. C. Bowman, Lancaster, Pa., St. Denis H.; Benj Allen, Chicago, Ill., Windsor H.; M. Cohen, Washington, D. C., Marlborough H.; C. M. Davidson, Cincinnati, O., Astor H.; H. A. Guild, Boston, Mass., Astor H.; J. V. Anderson, Toronto, Ont., St. Denis H.; J. N. Paul, Boston, Mass., Astor H.; J. Leslie, Minneapolis, Minn., Astor H.; E. Deming, Hartford, Conn., Broadway Central H.; A. Lewis, Syracuse, N. Y., Astor H.; J. E. Tyler, Richmond, Va., Imperial H.; W. T. Paddock, Bridgeport, Conn., N. Christensen, Chicago, Ill., International H.; W. C. Ball, Cleveland, O., Astor H.; J. M. Harper, Philadelphia, Pa., Jefferson H.; C. T. Anderson, Reading, Pa., Astor H.

### Delays Favor the Spread of Flames.

NEWARK, N. J., March 30.—A fire which caused a loss of about \$8,000 occurred at an early hour this morning in the factory at the corner of McWhorter and Hamilton Sts. The place is owned by T. & G. Stone. The flames were first discovered in the basement, and the man who discovered the fire tried to send in an alarm from box No. 51, at the corner of Hamilton and Union Sts., but the box would not work and he had to run to the Market St. Depot.

When the fire engines arrived at the Market St. crossing of the Pennsylvania Railroad they were prevented from crossing by a long freight train, which was passing. The block lasted for several minutes, and by the time the scene was reached the flames had gained considerable headway. The building is occupied by John W. Reddall & Co., jewelers; Thos. and Geo. Stone, of the Newark Engraving Works; Sheridan & Devine, pearl button manufacturers, and H. Allsopp & Co., jewelers.

Comparatively little damage was done to the jewelry stock of Reddall & Co.

Henry G. Thresher, of Waite, Thresher Co., has been renominated for representative to the General Assembly by the Republicans of Lincoln, R. I.



**The Death of Edgar Olmstead Bulkley.**

Edgar O. Bulkley, an old and esteemed employe of Tiffany & Co., New York, died suddenly of heart failure, after a brief illness, on Monday evening, March 26.

Mr. Bulkley was born in Ashford, Conn. His parents were Ichabod and Harriet Simons Bulkley. His father was at one time Lieutenant-Governor and a prominent lawyer in the State. Edgar went to Hartford as a boy, and after being in the jewelry business for a time went to New York, and for a number of years was engaged with William D. Briggs, a well-known local jeweler at that time. Later he became connected with the old house of Ball, Black & Co., and left them to enter into an engagement with Brown & Spaulding, who presented him with a handsome gold watch as a token of their regard and high esteem when they retired from business in 1871. Mr. Bulkley then entered the employ of Tiffany & Co., with whom he remained until his death. He was a member of the Fourth Company, Seventh Regiment, and of the Seventh Regiment Veteran Association. During the war he participated with his company in the campaign of June, 1863.

The deceased was quiet, unobtrusive, and possessed a peace loving, gentle character—his amiability being only less conspicuous than his sterling integrity. He leaves a widow. The funeral services were held at the residence of his brother-in-law, 69 West 68th St., Wednesday evening, and were largely attended by his employers and associates in business. The interment took place at Woodlawn Thursday morning.

**The Assets and Liabilities of Andrews & Doty.**

Geo. W. Glaze, assignee of Andrews & Doty, the diamond brokers at 207 Broadway, New York, who assigned Feb. 6th, filed his schedules with the clerk of the Court of Common Pleas Thursday.

They show the actual liabilities of the insolvent firm to be \$23,148.04, with contingent liabilities from indorsement on notes of \$38,890.88, making the total liabilities \$62,038.92. The assets are given as nominally worth \$153,848, and actually worth \$2,874. This big discrepancy is in great part due to the fact that no actual value is given to the personal assets of Mr. Andrews or Mr. Doty (\$58,550 and \$62,500, respectively) as the bulk of this is in stock, the value of which can only be determined when it is sold. The assets consist of the following:

	NOM. VALUE.	ACT. VALUE.
Fixtures.....	\$856.94.....	\$337.00
Merchandise on hand.....	220.50.....	136.59
Merchandise on memorandum.....	110.00.....	110.00
Notes due.....	4,400.00.....	worthless
Notes held by Krementz & Co. as collateral.....	550.00.....	nothing
Notes held by W. R. Alling.....	4,133.00.....	1,653.49
Book accounts due.....	22,520.72.....	631.00
Personal assets—J. R.,		

Andrews..... \$8,550.00 ..... not known  
 Personal assets—J. G.  
 Doty..... 62,500.00..... not known

Among the creditors of the firm are: Lewis, Kaiser & Luthy, Schulz & Rudolph, S. Dessau, Krementz & Co., Kuhn, Doerflinger & Co., E. Karelson & Co., W. R. Alling and James Stillman.

**Providence.**

William Loeb has returned from an extended trip through the west.

E. L. Spencer, of E. L. Spencer & Co., has returned from a successful trip in the west.

Albert Eddy, an old time manufacturing jeweler, is about to open a dispensary on Middle St.

The Republicans of Cranston have nominated S. K. Merrill, of S. K. Merrill & Co., for Senator.

The will of the late John C. Knowles will be entered for probate in the Municipal Court on April 17th.

Frank J. Johnson, until recently with the Excelsior Chain Co., is about to start in business on Eddy St.

Foster & Bailey have added a large and beautiful line of silver novelties to their long list of manufactures.

E. S. Stacy, Roanoke, Va., has been in town the past week calling upon the manufacturers and placed several orders.

Real estate on Point St., below to Ezra S. Dodge is advertised for sale at public auction by the mortgagee on April 21st at 12 o'clock.

Willard Davis, of the Providence branch of the Jewelers' Mercantile Agency, has been confined to his home during the past week by illness.

The board of directors of the Gorham Mfg. Co. have declared a quarterly dividend of 1½ per cent. on the preferred stock, payable Monday, April 2.

Real estate belonging to Andrew S. Southwick and wife in Linwood is advertised for sale at public auction by the mortgagee on April 20th at 12 o'clock.

William F. Leeder, of Leeder & Bernkopf, who has been absent in Europe for several weeks in quest of novelties, returned home Saturday on the *Havre*.

James Goodwin, who was reported last week as missing has been heard from. The report of his probable death was all a canard which his relatives are endeavoring to terret out.

The case of William H. Herrick against Mrs. Ellen E. White for \$200, claimed as commission for selling real estate, was before the courts in this city last week, and verdict rendered in favor of the defendant.

Charles G. Bloomer was tendered a rousing reception on Wednesday evening by the members of the Rhode Island Yacht Club. During the evening he was the recipient of a handsome easy chair and a pair of imported marine glasses.

The General Assembly has passed an amendment to the act of incorporation of the Burdon Seamless Filled Wire Co. by which the name is changed to the Burdon Wire Supply Co., and also authorizes a reconstruction of its system of capitalization.

Last Wednesday in the General Assembly, the petition of William L. Ballou, Walter D. Burlingame and others was presented for an act incorporating the William L. Ballou Co. with a capital stock of \$150,000 for the purpose of manufacturing and dealing in silver goods, diamonds and precious stones.

The Gorham Mfg. Co. have petitioned the Legislature to refund \$1,200 for excess of taxation on their increase of capital stock, which was claimed by the assessors to have been increased to \$6,200,000 instead of to \$5,000,000. The company paid the same under protest to the General Treasurer and now ask that it be returned to them by order of the General Assembly.

**The Attleboros.**

R. Blackinton started for New York Friday to visit New York firms.

E. I. Franklin has been elected chairman of the North Attleboro water commission.

At the annual meeting of the Episcopal Society Albert To ten, W. W. Fisher and E. E. Barrows were chosen State delegates.

W. A. Bushee, aged 78 years, died Wednesday. Members of his family have been quite prominent in the jewelry industry.

At the meeting of the Attleboro Savings Bank, G. A. Dean, Abiel Coddington, J. H. Sturdy, J. L. Sweet, Randolph Knapp, J. G. Barden and B. S. Freeman were chosen a board of investment.

The Attleboro, North Attleboro and Wareham electric railroad, has been sold to William H. Haskell, of Pawtucket, for \$25,000. C. L. Watson was the closest competitor and intended to purchase the property for a syndicate of jewelers. Before the assignment, H. M. Daggett, George Demarest, H. G. Bacon and other jewelers were stockholders.

**NEW I IMPROVED NEW I**  
**Adjustable "Eclipse" Eye Glasses.**

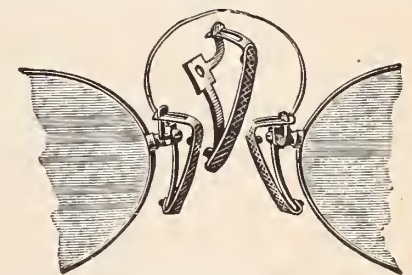

PATENT APPLIED FOR.

We claim this invention to be the only one which combines the advantages of both the adjustable and offset guards. We will furnish these frames or guards in either Zylonite or Cork.

WRITE FOR CIRCULAR,  
**JOHN SCHEIDIG & CO., SOLE AGENTS'**  
 43 MAIDEN LANE, NEW YORK,



THE ROAD OF PROGRESS WESTWARD TAKES ITS WAY

# WESTERN SUPPLEMENT

## of THE JEWELERS' CIRCULAR

**Chicago Office: Room 517, Inter-Ocean Building.**

VOL. XXVIII.

CHICAGO, WEDNESDAY, APRIL 4, 1894.

No. 9.

### Chicago Notes.

Lou Sterling left for Philadelphia Saturday after a week's visit here.

Ansonia Clock Co. report business for March 33 1/3 per cent. better than that for February.

C. F. Willemin, the ring man for H. Muh's Sons, left Chicago for the west Thursday.

Will G. Andersen, mother and sister, left March 26th for a three months' tour of California.

Arthur Fray, watchmaker and jeweler, has opened a small store in the south half of 185 N. Clark St.

F. J. Aicher, formerly of Spaulding & Aicher, Minneapolis, Minn., is visiting indefinitely in this city.

R. L. Moorhead reached Chicago Thursday on an investigating trip among the trade, returning east Monday.

E. A. Dorrance, manager of the Chicago branch of Simons, Bro. & Co., spent the week with the trade in Illinois cities.

O. R. Ryan and C. E. Patterson, representing the Towle Mfg. Co. in the west, were at the Chicago house for a few days last week.

President Thomas, of the Manhattan Silver Plate Co., reports from San José, Cal., that it is a grand country. Trade on the coast is quiet.

R. M. Johnson returned after a two weeks' visit at West Baden and three weeks at Hot Springs, showing the beneficent effects of recuperating at these popular resorts.

A good line of tools, materials and jewelry was sold by dealers the past week to E. O. Manahan, formerly of Crescent City, Ill., who is starting a store at Grant Park, Ill.

Among the buyers here last week were met: Mr. Alsted, of the C. Preusser Jewelry Co., Milwaukee, Wis.; G. F. Lindvoll, Moline, Ill.; L. H. Bauer, Elgin, Ill.; E. E. Chandler, Boone, Ia.

W. H. Mack, formerly in business at State

and 43d Sts., some time since went to Florida, expecting to invest in Florida lands. Mr. Mack has returned to face a Chicago blizzard. "It's a pretty good town here after all," he declared.

George Frick, with Stein & Ellbogen Co., has returned from a two months' trip in the west and southwest and reports dealers buying prudently. "All look for an improvement when Spring opens," said he, "and feel they will have a good Fall business."

The Warner Silver Mfg. Co. have incorporated, with a capital stock of \$25,000 for the manufacture and sale of silver ware and plated ware, and to transact a general mercantile business in connection therewith. The promoters are Augustus Warner, Paul B. Warner and Cassius C. Palmer.

A fine painting in oil of Sebastian Andersen, late president of the Juergens & Andersen Co., was hung the past week in the private offices of the company. It is the work of a Chicago artist, C. F. Schwerdt, and is well executed, the flesh tones being lifelike and the expression very natural.

Previous to the blizzard a week of sunshine showed a marked improvement in the retail trade both in the downtown and outside districts. The cold weather and storms again placed trade on its former level. The advent of reasonable weather is looked forward to as introducing a most encouraging trade revival.

Winslow & Penney, 608 Masonic Temple, have just added to their plant for watch repairs a wheel cutter of latest model, by which they are enabled to turn out anything required in wheels, music box gear, or in short, any work requiring tooth or gear cutting. The firm are receiving numerous orders from jobbers for special wheels.

A familiar landmark was missing Saturday from State St., Mayo & Co., Palmer House block, having completed their removal on that day to 48 Monroe St. The new location adjoins the ladies' entrance to the Palmer House parlors. Doors also lead from the store into the ladies' entrance hall

and into the hotel rotunda. The quarters are double in size those occupied by W. A. Bigler and are well appointed and nicely arranged.

George W. Lusk, the well-known jewelry auctioneer, completed the past week a most successful sale for Wolf & Co., 41 Michigan Ave., Detroit, and left Chicago Wednesday to conduct a sale for G. A. Woodford, Menominee, Mich. Mr. Lusk guarantees a profit over cost price, and his abilities as an auctioneer are attested by upwards of 300 wholesale and retail jewelers, for whom he has made satisfactory sales. Of commanding presence, and with a persuasive style of putting his ideas in the right light, he is possessed of two qualities that in themselves assure prosperous sales.

President Martin, of the Chicago Ophthalmic College, is justly proud of his graduates of the March course and pays them the compliment of being as studious a class as was ever granted diplomas. It was noticeable that members of this class, almost without exception, were well grounded in the rudiments of optics and were not unfamiliar with the trial case, but realized the benefits to be derived from an advanced course under the able mentorship of Dr. Martin. The March graduates follow: H. W. Hayne, Lawrence, Kan.; G. A. Brock, Chicago; W. C. Sommer, Chicago; Jos. B. Gibbons, Charlotte, Mich.; H. B. Shellito, Sault Ste. Marie, Mich.; A. M. Smythe, Elgin, Ill.; H. F. Schmidt, Terre Haute, Ind.; H. E. Knowles, Rockport, Ill.; J. C. Hicks, Lanark, Ill.; H. E. Boughton, Brooklyn, Ia.; Mrs. F. M. Tucker, Des Moines, Ia.; W. J. Dunn, Owen Sound, Canada; Carlin H. McClure, Watersmeet, Mich.; Royal G. Foss, Oconomowoc, Wis.; Ezra Nuckolls, Eldora, Ia.; I. Jacobs, Winterset, Ia.; G. Anderson, Taylorville, Ill.; G. A. Hewitt, Neligh, Neb.; S. D. Littlefield, Delavan, Wis.; W. H. Grimwood, Illinois; C. M. Hall, Waupaca, Wis.; E. A. Sigler, Hebron, Ind.; E. F. Kirshgessner, Tecumseh, Mich.; R. G. Wells, Wellsville, N. Y.; J. M. Greer, Evans City, Pa.; Charles Q. Holden, Christian, Ia. The next course begins May 1



Those desiring to take an optical course should early avail themselves of this opportunity to place their names on Dr. Martin's list.

General Manager J. M. Cutter, of the Elgin National Watch Co., returned Thursday with Mrs. Cutter, from a three weeks' tour in California.

Glickauf & Newhouse, 86 State St., the past week shipped to Nebraska one of the largest watch signs ever produced by the Excelsior Sign & Mfg. Co.—one of Grout's 42 inch Louis XIV. English twist pendent signs, designed to ornament a post of Roman pillar design. The post for this colossal sign is in black and gold with a brightening of vermilion and gold, is 10 ft. in height and a decided departure from the previous styles issued. A total of three huge signs in a single day's shipment is a good record and speaks well for the quality of the product. Glickauf & Newhouse report a gradual strengthening in sales of tool and materials and an encouraging outlook for the opening of Spring.

**John Birnstein "Bucked the Tiger" With Disastrous Results.**

KANSAS CITY, Mo., March 29.—John Birnstein, traveling salesman for M. C. Eppenstein & Co., Chicago, arrived in Kansas City early last week. He went to the gambling houses near the State line in Kansas City, Kan., and lost all his ready

cash at faro. He then got a relative to cash a draft on the house for \$50 and lost that. The firm refused to honor the draft.

Having exhausted all other resources, Birnstein pawned about \$1,200 worth of samples, getting about \$250 on them. He sold some more outright and the police learned of it. Detective Woodruff, of Kansas City, Kan., arrested him at a gambling table Tuesday night. He had only \$10 left. His employers were telegraphed, and this morning J. H. Oppenheim, a representative of the house, arrived in Kansas City, Kan., and took charge of what was left of the stock. Birnstein's bond is \$3,500, secured by his sister, who is blind.

**Kansas City.**

John M. Earp, Lamar, Mo., was here a few days ago.

E. A. Douglas has moved his stock from Norton, Kan., to Goodland.

J. D. Toy, watchmaker, has opened an establishment in Kingston, Mo.

Mrs. B. B. Pollock, Oklahoma City, is visiting friends in Kansas City.

C. B. Norton has been spending several days hunting in southern Missouri.

E. J. Robison has moved his jewelry store from Plattonsburg, Mo., to McFall.

Ed. Massa, of the Bauman-Massa Jewelers' Supply Co., St. Louis, was in Kansas City last week.

James B. Hayden, Topeka, Kan., was in Kansas City last week buying goods.

F. A. Hayden has closed his store in Topeka, Kan., and moved his stock to Bowie, Tex.

Henry M. Tallman was here last week taking orders for Irons & Russell, Providence, R. I.

Mr. Louis, watchmaker for James B. Hayden, Topeka, Kan., was in Kansas City a few days ago.

The Jaccard Watch & Jewelry Co. are preparing to place automatic electric change makers and cash registers in their store.

The Jaccard Watch & Jewelry Co. are making the souvenirs to be distributed by the Commercial Club on their trip to be taken to the south in a few days.

E. B. Lane, formerly a jeweler in Armourdale, will represent the Julius King Optical Co. and J. A. Norton & Son on the road. He is now preparing his sample cases.

Gerald Otwell, E. D. Tanguary and J. R. Butler have each opened a new jewelry store and D. B. Butcher an optical goods store in Neodesha, Kan., during the past few days.

Geo. B. Bowers, Lynden, Kan., whose store was seized under attachment several days ago, won the cases in court and the attachments were dismissed. He is still doing business and is paying his bills as fast as they become due.

**TWO PAIR !!**



Two pair beat two of a kind in illustrating the advantages to be derived from dealing with Goldsmith Bros. In March Jewelers Joy and Happy, depicted in the left in the above illustrations, were two of a kind in their opinion of the firm. They agreed that the tests were accurate and valuations correct, and were pleased to get cash remittances on receipt of shipment. This month Jewelers Grumpy and Hardscrabble were overheard discussing their woes.

GRUMPY—No Sir; I'll never do it again.  
 HARDSCRABBLE, (testily)—Do what?  
 GRUMPY—Send stuff to Graball & Skinem, those sweep and old gold and silver fellows.  
 HARDSCRABBLE—Not I.  
 GRUMPY—So you sent to them, did you? Well, I had been sending to Goldsmith Bros. and was satisfied, but thought I'd change. It was a change all right, but its Goldsmith with me hereafter.  
 HARDSCRABBLE—Me too; I changed, and wish I hadn't,  
 And they fell upon each others necks and vowed Goldsmith Bros. gave best returns.

TWO PAIR as an illustration win more to our standard than TWO OF A KIND.

**GOLDSMITH BROS.,**  
**GOLD, SILVER AND PLATINUM REFINERS,**  
**63 and 65 WASHINGTON ST., CHICAGO, ILL.**



**The Assets and Liabilities of F. J. Essig.**

CHICAGO, Ill., March 30.—The assets and liabilities of F. J. Essig, the lapidist at 1222 Masonic Temple, who assigned voluntarily March 19, cannot be ascertained with exactness, as attorney Cahill is in New York with the accounts looking for a settlement with the firm's creditors. Stated in round figures the assets consist of stones valued at \$2,000, and the liabilities are \$5,000, all for purchases from eastern stone houses. The principal creditors are: Max Nathan, \$900; Rud. C. Hahn, \$700; M. Fox & Co., \$600; L. Tannenbaum & Co., \$550; R. A. Breidenbach, \$800; Albert Wild, \$125, and a considerable number of small accounts.

The machinery of the plant was mortgaged two years ago to Mr. Essig's father for \$800 and cannot be regarded an asset. It is understood offers of settlement will be made at 15 per cent. on short time, with a total settlement of 25 per cent. A loss in recent months of from \$150 to \$200 per month in sapphire cutting prevented the firm taking up its outstanding paper and

caused the assignment of the firm.

No action will be taken in the local courts till the attorney returns.

**A Daring Theft and a Rapid Capture.**

ST. JOSEPH, Mo., March 28.—Louis Burnett & Co.'s jewelry store at the corner of 7th and Felix Sts. was the scene of a bold daylight robbery this week. Two men entered the store and one of them asked to look at some rings. The other thought he would like a pair of cuff buttons. The men made examinations of goods shown as if they meant to buy. Among the rings was one valued at \$75, while the others were cheaper.

All at once the pretended customers said they would not buy and started to walk out of the store. It was then observed that one of them had a \$5 ring in his mouth, while his companion had a pair of cuff buttons of equal value. Simon Burnett, a member of the firm, gave chase and grappled with one of the men, while another party from the store went in search of a policeman. Mr. Burnett, however, had to let go, when he

was knocked down and a big knife drawn on him. The police later captured one of the robbers. When taken to the station he gave the name of Pat O'Brien.

J. C. Carlson, partner of Pat O'Brien, was gathered in next morning and held for preliminary hearing.

**Indianapolis.**

L. F. Kiefer has returned from his Florida orange grove.

A. Kipp, of Kipp Bros., has returned from a purchasing trip to New York.

E. C. Miller was elected a vestryman of St. Paul's Episcopal Church, March 27th.

C. N. Hetzner, Peru, Ind., was here last week attending the Masonic Convocation.

J. E. Reagan made a business trip to Fairmont, Ind., last week in the interest of Baldwin, Miller & Co.

Craft & Koehler have just finished some handsome gold badges for the Indianapolis Training School for Nurses.

Jno. A. Spurrier, Rushville; L. C. Phillips

**THE DALE CHUCK**

Is as well known as any on the market, and it has the best reputation.

**ALL KINDS \$1.00.**

MADE ONLY BY



**HARDINGE BROS.,**

1036 LINCOLN AVE., CHICAGO.

**R. M. JOHNSON,**

IMPORTER OF

**Diamonds and Manufacturing Jeweler,**

67 WASHINGTON STREET,

ROOMS 5 & 6,

CHICAGO.

MASONIC EMBLEMS OF EVERY DESCRIPTION MADE TO ORDER.

**REED & BARTON,**

**SILVERSMITHS,**

MANUFACTURERS OF

STERLING *and* SILVER PLATED  
SILVER *and* WARE.

SALESROOMS:

**37 Union Square, New York.**

34-36 WASHINGTON STREET,

**Venetian Building, Chicago.**

FACTORIES, TAUNTON, MASS.

**DUEBER-HAMPDEN WATCHES.**

The most reliable watches are the Hampden 17 Jewel. A full line of Dueber Cases and Hampden Movements. Cash buyers write us.

**BRETHAUER WATCH & JEWELRY COMPANY,**

SPECIAL AGENTS,

71 WASHINGTON ST., - - - CHICAGO, ILLS.

**THE PLANCHAMP & BECKER CO.**

Makers and Repairers of

**WATCH CASES,**

Gold and Silver Plating —

— of Watch Cases a Specialty.

UNEXCELLED FACILITIES.

63 and 65 East Washington St., Chicago.

WHEN IN CHICAGO, VISIT THE

**Chicago Watchmakers' Institute,**

SUITE, 1521-1523 B MASONIC TEMPLE.

A Modern Trade School for the Watchmaker, Jeweler and Engraver.

Write for New Catalogue.





Carbon; M. A. Fry, Greenfield and J. W. Hudson were some of the Indiana dealers seen among the jobbing houses last week.

R. W. Randle has opened a repair shop in Portland, Ind.

Johnson Bros., Spencer, Ind., have been succeeded by Oliver H. Johnson.

George Stanley has removed his jewelry stock from Dayton, Tenn., to Connersville, Ind.

H. H. Phillips has returned to his eastern home after selling at auction his stock in Dunkirk, Ind.

**Minneapolis and St. Paul.**

B. F. Straub; Faribault, Minn., on March 23d was nominated as Democratic candidate for mayor of that city.

George Hartman, St. Paul, last week made a trip to Litchfield, Minn., spending several days there on business of importance.

Louis Finkelstein, St. Paul, contemplates renting office rooms in the Endicot building, corner 4th and Robert Sts., and will then remove his jobbing business recently established at 84 E. 7th St., to that place.

J. F. Elwell, for a number of years past, watchmaker and salesman for Wm. Donaldson & Co., Minneapolis, has severed his connection with that firm and contemplates starting in business here for himself.

F. W. Upson, watchmaker and optician, formerly with B. B. Marshall & Son, Minneapolis, has opened in business at 19 4th St. S., with a fine line of optical goods. He will make watch repairing his specialty.

John Pfister, St. Paul, one of the oldest jewelers in the city, is advertising his stock and fixtures for sale, and will retire from business, owing to his wife's poor health. He will make southern California his future home.

Ellis Long, of Long Bros., Sheldon, Ia., jewelers, and owners of the Post Office store, died of rheumatic fever on March 21st, and was buried at Muscatine, Ia. Edward Ellis, the junior member of the firm, is ill with the same disease.

Eastern jobbers and manufacturers represented in the Twin Cities the past week were: Max Nathan, by Alfred Nathan; Nicholson File Co., by W. S. Tragle; E. G. Webster & Son, by Mr. Coutts; Dennison Mfg. Co., by Alfred Varian.

Newton Dexter, secretary of the Business Men's Association of New York, is in the Twin Cities trying to organize an association among the retail jewelers, and will inaugurate a crusade against manufacturers that spread their products all over the country outside of the legitimate trade.

**Detroit.**

The statue of Ada Rehan will arrive in this city next week, where it will be placed on exhibition.

In a fire that destroyed the business portion of Litchfield last week, W. A. Sherwood, jeweler, lost \$500.

A picture by Jules Rolshoven, painted in Paris, is on exhibition in the window of J. F. Rolshoven & Co.'s jewelry store. It represents a choir boy.

George L. Lowe, traveling salesman for Kennedy & Koester, returned from a northern Michigan trip last week. He reports business as fair. Frank Mathauer will start about April 5 for Ohio and Indiana.

The following Michigan country jewelers passed through Detroit last week: I. D. Lane, Sand Beach; E. A. Cress, Minden City; Fred Wells, Flushing; F. A. Humber, Canada; and C. E. Montfort, Utica.

W. H. Grenfell, western representative at Detroit, for the Silver Metal Mfg. Co., Oswego, N. Y., and president D. J. Tuthill met here last week to perfect arrangements for starting a manufactory in Chicago. The firm already have a finely appointed office at 19 Wabash Ave., with E. A. Barkelew in charge.

The following traveling salesmen passed through Detroit last week: A. E. LaVigne, Mathey Bros., Mathez & Co.; S. W. Abbey, E. Ira Richards & Co.; R. M. Wilcox, Rogers, Smith & Co.; Gerry Kingman, G. A. Dean & Co.; M. L. Jacoby, Providence Stock Co.; Mr. Case, Pairpoint Mfg. Co.; and E. L. Spencer, E. L. Spencer & Co.

**Cincinnati.**

Wm. Mount, of T. Quayle & Co., Providence, was visiting Cincinnati trade last week.

Duhme & Co. have received another fine lot of Rookwood pottery, which they have on exhibition.

Mr. Miller, of the Seth Thomas Clock Co., was in Cincinnati last week, and said he had noticed a decided improvement in his line since his last trip.

Jos. Noterman & Co. made some very elegant badges the past week. Their travelers will take next trip a new line of King's Daughters pendants.

W. H. Ludwig window dresser for Oskamp, Nolting & Co., since Sept. 1, '93, has severed his connections with the firm and will return East.

L. Lange, traveler for A. G. Schwab & Bro., returned Saturday with a battered trunk. It was struck by a freight train, while on the platform in a town in the northern part of the State.

Gustave Fox & Co. are being congratulated on the elegant locket they made last week for the Cincinnati Lodge of Elks. It is square shaped with a 1/4-karat diamond in each corner. It contains an elk's head with ruby eyes and diamond collar with the letters B. P. O. E. in the horns upon which Gustave Fox has a patent. The monogram on the reverse side is composed of rubies.

**Jewelers' Auctioneer.**



**NEVER A FAILURE.**

References from over 300 Wholesale and Retail Jewelers in all parts of the country. Profits Guaranteed. Correspondence Confidential. Write for terms and details.

**501 MASONIC TEMPLE,  
CHICAGO.**

**CHAS. H. PFEIL,**

**MANUFACTURING JEWELER.**

**Diamond Work a Specialty.**

**BEST of Workmen.  
BEST Design Work.  
GUARANTEED Workmanship.**

Send a trial order and be convinced.  
**182 State St., Chicago.**

**HUGO MUELLER,  
182 State St., (Room 70,) Chicago.**

**FINE WATCH REPAIRING**

IN ALL ITS BRANCHES.

Work for the trade promptly executed by skilled workmen.

**PARSONS : SCHOOL**

—FOR—

**WATCHMAKERS,**

**PEORIA, - - - ILL.**

Send for Circular and Terms.

**PARSONS & CO**

**BOLSTAD MFG. AND PLATING CO.,**

(H. E. BOLSTAD, PRES.)

WATCH CASE MAKERS, REPAIRERS. PLATERS.  
PLATED INLAYING ON CASES.

**BEST WORK. BEST WORKMEN.**

**170 MADISON ST., - CHICAGO.**

**ELGIN HOROLOGICAL SCHOOL,**

**THOROUGHLY PRACTICAL.  
COMPETENT INSTRUCTORS.**

Send for Prospectus.

**ELGIN, ILL.**



# PATENT FIBRE-FACED HAMMERS.

5 oz. for Watchmakers.  
10 oz. for Manufacturing Jewelers  
Price 50 Cents Each.

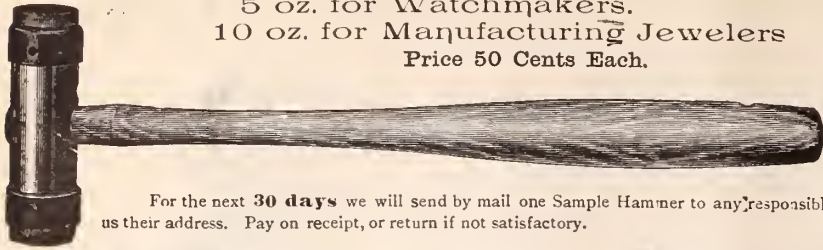

For the next 30 days we will send by mail one Sample Hammer to any responsible firm giving us their address. Pay on receipt, or return if not satisfactory.

**W. W. OLIVER, Sole Manufacturer, - Buffalo, N. Y.**

Send for our No. 10 Catalogue.

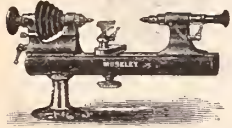

One of the best of the very best.

QUALITY IS THE STANDARD OF VALUE.

CHARGES TO SUIT THE TIMES.

When interested, write your jobber for new price list for 1894, or

**Moseley & Co., Elgin, Ill.**



No. 2 Moseley Wire Chuck has length, strength, accuracy.



## GIBSON HOUSE,

CINCINNATI, OHIO.

ABSOLUTELY FIRST-CLASS AMERICAN PLAN HOTEL.

\$3.00 PER DAY.

Extra Charge for Parlors and Rooms with Bath attached. The unequalled advantages in central location, liberal management, modern appointments, experienced service and perfect cuisine, have permanently established the Gibson House as The Most Popular First-Class Hotel in Cincinnati.

AMPLE VAULTS FOR THE PROTECTION OF VALUABLES.

**THE GIBSON HOUSE CO.,**

H. B. DUNBAR

President and Manager

... THE ...

# American Horological Institute

AND TECHNICAL SCHOOL OF LANCASTER, PA.,  
LATE OF PHILADELPHIA, PA.,

A Trade School where Watchmaking is taught practically. We do not manufacture

✻ BICYCLES OR DYNAMOS ✻

at this institute. We confine our work strictly to WATCH WORK and its kindred branches, which include

== Engraving, Jewelry Work and Optics ==

One tuition pays for all the branches. We do not have boy instructors at this institute, all men of years of experience. Each department has its separate instructor. Our institute is open for inspection. We kindly invite you to visit us and inspect our school modes of giving instruction and the progress that our students make by giving them practical instruction.

**THOMAS PENDERGAST,**  
PROPRIETOR AND MANAGER.



## OPTICIANS' SCHOOL.

If you want a GOOD ROOF over your head, come to our school. We want EARNEST STUDENTS, leave the rest to us, we do not want diploma hunters.

The Chicago Ophthalmic College and Hospital,

H. M. MARTIN, M. D., PRESIDENT. 607 VAN BUREN ST., CHICAGO.

Being the oldest and most favorably known College of Theoretical and Applied Ophthalmic Optics in America, having more thoroughly qualified opticians in the field than all other so-called schools combined.

## Pacific Coast Notes.

Mark P. John, Pendleton, Ore., has assigned.

Max Kuner, Fairhaven, Wash., has removed to California.

George Green has opened a jewelry store in Waterville, Wash.

Chameleon breast pins are the rage in the Pacific northwest.

K. Gregoris de Silva, a jeweler and diamond importer, of Colombo, Ceylon, was a recent visitor in Seattle, Wash.

V. E. Campbell, jeweler. Mount Vernon, Wash., has invented a washing machine, a patent for which has been applied for.

N. E. Steuben has removed what was left of his jewelry stock at Visalia, Cal., to Tulare, Cal., and will close it out at auction.

Davidson Bros., Vancouver, Victoria and New Westminster, B. C., have sold their branch in New Westminster to John D. Bennett.

V. E. Campbell, Mount Vernon, Wash., has sold his stock of jewelry and musical instruments to E. W. Tiele and will hereafter devote himself to watch repairing.

F. C. Lawrence, New Whatcom, Wash., who left for Johannesburg, South Africa, last Fall with the intention of opening a jewelry store, has returned, well satisfied that there is no place like the United States.

B. M. Fink, Tacoma, Wash., has sued for a divorce from his wife. Several weeks ago, Mrs. Fink, who is of an intensely jealous disposition, smashed the show cases in her husband's store in revenge for some imaginary wrong.

Walter Guy Furnald, mention of whose arrest in Los Angeles, Cal., together with Mrs. Garner and her son, on a warrant charging Furnald with the robbery of Simon Jacobson, San Francisco, was made recently in THE CIRCULAR, has confessed the crime and returned his share of the booty. He claims that two men, George Young and James Wilson, stole the trunk and removed the jewels while he waited in a convenient place to help carry away the plunder. Furnald will undoubtedly be taught some trade other than the jewelers' at the expense of California.

F. W. T. and A. B. Lindsay, who have been doing business under the firm name of

EST. 1870. DR. PETER HENRY, SPECIALIST IN WATCH • CASE • DISEASES



Key Winders & changed to Stem Winders.

Hunting Cases changed to O. F.

English Cases changed to fit American movements

Can be cured at 53

Longworth St., Cincinnati, Ohio.



the West Coast Jewelry Co., San Francisco, have filed a petition in insolvency. Their liabilities amount to \$3,519.12 and their assets, consisting of jewelry and furniture at 141 4th St., amount to \$1,731.50. They have uncollectable bills to the amount of \$3,339.

**The Complete List of Merchandise Creditors of F. G. Smith, Sons & Co.**

DETROIT, Mich., March 30.—The following is a list of the creditors of F. G. Smith, Sons & Co., and the amounts due each: Falkenau, Oppenheimer & Co., \$6,995.60; Carter, Sloan & Co., \$2,947.19; Wilcox Silver Plate Co., \$2,712.96; Gorham Mfg. Co., \$2,098.41; Day & Clark, \$962.08; C. T. Smith, \$1,056.46; Kremetz & Co., \$1,372.24; Reed & Barton, \$1,526.20; Williamson & Co., \$228.30; Meriden Silver Plate Co., \$2,692.48; Keller, Ettinger & Fink, \$1,242.52; T. G. Hawkes & Co., \$1,385.25; Whiting Mfg. Co., \$1,231.17; M. A. Mead & Co., \$1,272.49; Wm. Rogers Mfg. Co., \$1,997.49; French & Franklin Mfg. Co., \$1,641.96; Oppenheim Bros. & Veith, \$1,980.14; I. W. Friedman, \$1,605.30; W. B. Durgin, \$4,696.64; Hayes Bros., \$342.90; W. S. Hicks' Sons, \$24.45; A. Joralemon & Co., \$244.28; Ansonia Clock Co., \$36.74; Reeves & Sillocks, \$44.03; Alling & Co., \$287.12; Block & Bergfels, \$118; M. B. Bryant & Co., \$165.38; Bradley & Hubbard Mfg. Co., \$46.76; S. Cottle Co., \$12.83; Cox, Cooper, Ward & Young, \$94.75; Dominick & Haff, \$580.57; Downing, Keller & Co., \$535.03; Durand & Co., \$246.45; Follmer, Clogg & Co., \$67.97; Groeschel & Rosman, \$81.25; W. S. Hough, Jr. & Co., \$14.67; Lewis Bros., \$12.38; A. J. Hedges & Co., \$778.10; Rogers, Smith & Co., \$730.94; Lincoln, Bacon & Co., \$43.10; Geo. O. Street & Sons, \$593.57; F. M. Whiting & Co., \$303.04; Enos Richardson & Co., \$276.32; American Morocco Case Co., \$158.10; Champenois & Co., \$88.10; Sussfeld, Lorsch & Co., \$491.37; Hodenpyl & Sons, \$1,109.68; G. E. Luther, \$20; Randel, Baremore & Billings, \$103.12; Snow &

Westcott, \$1,201.60; Seth Thomas Clock Co., \$346.42; J. F. Fradley & Co., \$92.50; E. G. Webster & Son, \$175.90; Waterbury Clock Co., \$3.20; Larter, Elcox & Co., \$154.94; Taylor & Bro., \$90; W. M. Fisher & Co., \$17.73; Howard & Sterling Co., \$144.75; Martin, Copeland & Co., \$227.12; Robbins & Appleton, \$2.09; Spencer Optical Mfg. Co., \$815.65; H. C. Hardy & Co., \$43.25; Lewis, Wessel & Leward, \$163.05; E. I. Richards & Co., \$74.59; Levy, Dreyfus & Co., \$211.14; H. J. Lingg, \$141.33; Unger Bros., \$560.69; Braillard & Pfingsten, \$387.54; A. Trenkman, \$15.53; Johnson Optical Co., \$163.02; F. H. La Pierre, \$283.70; L. W. Fairchild Co., \$127.13; Geo. W. Shiebler Co., \$802.54; M. Fox & Co., \$2.53; Ed. Todd & Co., \$5.07; A. Wittnauer, \$859.73; Simons, Bro. & Co., \$449.73; Shafer & Douglas, \$247.89; C. W. Sedgwick, \$24.40; Shoemaker, Pickering & Co., \$4.50; J. B. Bowden & Co., \$898.24; J. A. Riley & Sloan Co., \$414.10; Meriden Cutlery Co., \$138; G. A. Dean & Co., \$132.84; I. Bedichimer, \$271.25; D. Wilcox & Co., \$26.54; E. I. Franklin & Co., \$129.48; Rogers & Hamilton Co., \$30.26; Kent & Stanley Co., \$89.58; A. Lounsbury & Son, \$7.88; Brooks & Pike, \$119.90; A. Koehn, \$20.25; Barstow & Williams, \$28.17; Merrick, Roller & Holbrook, \$75.05; H. F. Carpenter, \$334.43; M. D. Rothschild, \$23.46; Max Freund & Co., \$335.35; F. W. Smith, \$482.60; Lewis, Kaiser & Luthy, \$56.25; Kuhn, Doerflinger & Co., \$361.96; Mayhew & Carrington, \$20; W. L. Ballou & Co., \$46.07; Alvin Mfg. Co., \$121; Hayward & Sweet, \$71.22; Nowacke & Co., \$101.37; De Raismes & Co., \$23.62; Bippart & Co., \$986.95; Kirby, Mowry & Co., \$104; Craighthead & Kintz Co., \$20.81; E. A. Bliss Co., \$38.75; Julius King Optical Co., \$33.35; T. B. Clark & Co., \$42.65; J. H. Jacobson, \$134.21; H. Hoehm & Co., \$135.75; Silver City Plate Co., \$61.63; H. H. Curtis & Co., \$163.50; I. Emrich & Co., \$58.14; J. W. Miller, \$56.25; Fink, Bodenheimer & Co., \$642.50; Hayden Mfg. Co., \$94.75; E. F. Sanford & Co., \$692; Ball, Parker & Waters, \$277.83; M. Levy, \$150; F. H. Jacobson,

\$9; Geoffroy & Co., \$182.65; A. J. Grinberg, \$165; Mt. Washington Glass Co., \$458.23; Eichberg & Co., \$6.50; Wm. B. Kerr & Co., \$211.08; Jno. Scheidig & Co., \$45.50; Kossuth Marx Jewelry Co., \$60; J. W. Richardson & Co., \$77.23; Strobell & Crane, \$198.49; Libbey Glass Co., \$857; Corey & Osmun, \$611; R. Blackinton & Co., \$894.73; R. Wallace & Sons Mfg. Co., \$236; J. W. Gibson, \$27; Nacke, Brinkmann & Co., \$402.50; C. Ahrenfeldt & Son, \$56.68; T. W. Adams & Co., \$17.90; L. J. Glaenger & Co., \$208.91; Landers, Frary & Clark, \$84.60; M. A. Pierce & Co., \$56.75; Powers & Mayer, \$983; Max Nathan, \$234; New Haven Clock Co., \$50; L. Black & Co., \$18; Lewisson, Boice & Smith, \$59; A. B. Risley, \$34; F. French & Bro., \$253; Meriden Britannia Co., \$6.67; Jules Laurençot & Co., \$67.73; Peter L. Krider Co., \$263; Kraus, Kragel & Kiersy, \$13.50; J. W. Reddall & Co., \$107; Rogers & Bro., \$114; Wilcox & Evertsen, \$633.75; W. S. Bery, \$164; McCue & Earl \$50; G. A. Schlechter, \$41; Hamilton & Hamilton, Jr., \$72; A. & J. Plaut, \$27.75; Barbour Silver Co., \$76.25; A. J. Kahn & Co., \$67.50; W. E. Whiteside & Co., \$65; C. C. Bartley, \$77; Ehrlich & Sinnock, \$20; H. L. Judd & Co., \$53; Parks Bros. & Rogers, \$21; G. H. Reibesten, Austria, \$720.60; R. Horstman, Berlin, \$735.75; Wm. Demuth & Co., \$146.25; Brown & Dorchester, \$2.83.

The inventory shows that the appraised assets are \$91,405.11; original cost of the stock, \$128,334.11; present value, \$93,733.40; due to eastern creditors, \$74,532; due to trustee Howard for local creditors, \$38,420.99; total liabilities, \$112,952.99. THE CIRCULAR representative had considerable trouble in obtaining the above facts, as County Clerk May had evidently received instructions to suppress them as long as possible. The papers were filed Wednesday, March 28th.

M. F. Warren Colorado Springs, Col., recently returned from the east where he went to stock up. He will soon refit his store with new store fixtures.

# JUST OUT!

## Our New Illustrated Catalogue of . . .

Watch Materials, Tools, & Jewelers' Supplies was issued MARCH 20th.

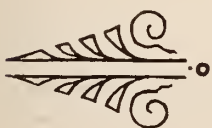

IF you have not already received a copy notify us and we will send you one at once. We wish to emphasize that our Prices will be found the LOWEST, quality of goods considered. With a well selected stock we are enabled to fill all orders promptly and correctly.

### BENJ. ALLEN & CO.,

141-143 STATE STREET, . . . CHICAGO, ILL.

Watches, Diamonds, Clocks and Jewelry.



Clock Co. After several years he gave this up and became a merchant in Ansonia, retiring some 14 years ago.

The heirs of the late president I. C. Lewis, of the Meriden Britannia Co., have presented the First Universalist Society of Meriden, with \$15,000, the income of which is to be devoted to the annual expenses of the church. The gift is in memory of Mr. Lewis, and will be known as "The Isaac C. Lewis fund."

**Looks Like a Conspiracy to Fleece David Keller.**

On indictments procured by David Keller, of Keller, Ettinger & Fink, 24 John St., New York, two lawyers, Samuel J. K. Adler and Wm. Vanderzee were arrested March 27th, the former charged with grand larceny and impersonation and the latter with conspiracy.

Mr. Keller testified before the grand jury that Adler came to him last December and represented that a friend, Jacob E. Solomon, desired to obtain a mortgage on a dwelling at 341 E. 82d St. Solomon, it is said, wanted to realize \$4,500. M. Keller said he agreed to advance the money, but before doing so consulted his lawyer, W. A. Ganz. The latter reported that the deed was not on the house, 341 E. 82d St., but on a frame dwell-

ing at No. 345. On the latter Lawyer Ganz found there was a mortgage of \$10,000.

Adler's charge of impersonation is founded on his having, it is alleged, gone before James Murphy, a Commissioner of Deeds in Nassau St., and represented himself as being Jared Q. Amos, owner of 345 E. 82d St. It is alleged that Vanderzee prepared the papers in connection with the procurement of the loan. Both were held in bail for trial, Adler in \$7,000, and Vanderzee in \$3,500.

**Annual Meeting of the American Waltham Watch Co.**

WALTHAM, Mass., March 31.—The annual meeting of the stockholders of the American Waltham Watch Co., was held Thursday at the treasurer's office, 11,300 shares being represented at the election of officers, which resulted as follows: President, Ezra C. Fitch; reasurer, Roy I. E. Robbins; directors, Joshua V. Kettell, Benjamin F. Brown, A. Lawrence Edmunds, Daniel F. Appleton and George H. Shirley; clerk, Philip W. Carter.

This gives the directory two new members, D. F. Appleton and George H. Shirley taking the places of Benjamin F. Stevens, resigned and Charles W. Fogg, deceased.

**Boston.**

The E. Howard Watch & Clock Co. are erecting a "Parsifal chimes" four-dial tower clock, the finest in New England, on the new public building in Salisbury, Conn.

Mrs. Cowan, wife of jeweler E. A. Cowan, of this city, who was seriously injured in a recent railway accident, while traveling with her husband south, is slowly recovering under the care of two nurses at San Antonio, Tex., where she will remain until able to return to Boston.

Merrick Harwood writes from California that he has enjoyed there the hospitality of L. F. Darling, formerly the leading jobber in Halifax, N. S., and well-known in New England, who now has a ranch at Riverside, and from whose fruit groves have been selected some of the finest specimens shown at the California Mid-Winter Fair.

Among the successful sales which H. M. Rich & Co., the well-known jewelers' auctioneers, 61 Hanover St., have recently conducted, were two in New England which proved so satisfactory that they elicited testimonials from the jewelers, S. A. MacKeown, Lawrence, Mass., and L. G. Burnham, Burlington, Vt. Both highly recommend the auctioneers. Rich & Co. also conducted a sale for Otto Offenhauser, Schenectady, N. Y.



**\$500 Reward**

will be paid by the undersigned on delivery to the police authorities in New York, of

**SIMON M. JACOBS,**

who is wanted for grand larceny. Age about 30 years, 5 ft. 7 inches in height, medium build, has dark hair and eyes, dark sandy moustache, dresses nobbily, was a traveling Diamond Salesman, and lately Life Insurance Agent, is considerable of a sport, visiting race tracks and pool rooms.

SCHULZ & RUDOLPH,

24 John Street.

LUDEKE & POWER,

23 John Street.

**R., L. & M. Friedlander,**



IMPORTERS OF  
**DIAMONDS.**

WHOLESALE  
**JEWELERS.**

JOBBER IN  
**American Watches.**

Tools, Materials, and Optical Goods.

Send for Catalogue.

65 & 67 Nassau Street, New York.



**Connecticut.**

George D. Munson is home in Wallingford from a western trip.

Newton & Co., Winsted, are having the interior of their store handsomely improved.

Captain and Mrs. D. B. Hamilton, Waterbury, were sojourning in Redlands, Cal., last week.

Prof. J. H. Caruss, optician, Stamford, was on Thursday married to Miss Dale Divan, of Beaver, Pa.

Mr. Perry, of Perry & Stone, jewelers, New London, has bought from the Janes property a fine building lot on West St., in that city.

J. B. Gardner's Sons' clock dial factory, Ansonia, has been run six days a week up to the present week. Business is as good as it has been since last Fall.

Jeweler S. H. Kirby, New Haven, has just removed to his new location on Chapel St., a few doors east of his old store. He has had the new premises handsomely fitted up and equipped.

Rider, Bryant & Co., Danbury, have secured a portion of the second floor of the building in which their jewelry store is situated and will fit up a complete watch and jewelry repair shop.

John Dawson and Charles Ne for several years employed by the Waterbury Clock Co., have started in business in New York city. They will manufacture novelties and also do plating, buffing, lacquering, etc.

George Hallenbeck's silver plate shop, in Wallingford has been attached for \$10,000 by attorney John W. Coogan in a suit brought by Dennis J. Buckley for injuries received by Patrick J. Buckley, a minor.

The soliciting committee of the Wallingford fire department have received the following donations: Simpson, Hall, Miller & Co., \$50; R. Wallace & Sons Mfg. Co., \$50; Maltby, Stevens & Curtiss Co., \$25; Housatonic Mfg Co., \$15.

A large petition circulated in the seventh ward, Hartford, to have Wm. H. Watrous, of the Wm. Rogers Mfg. Co., run for alderman was presented to him Wednesday and he consented to stand for the office although at first he had been much averse to the idea.

Gen. George H. Ford was, on March 28, elected vice-president of the New Haven Chamber of Commerce, the oldest chamber of commerce in the United States except that in New York, and which is now preparing for a grand celebration of its 100th anniversary. Gen. Ford made the report of the committee which is arranging the commemorative program.

Last Saturday some person or persons made forcible entrance to the factory of Dickerman M. Bassett, in Shelton, and purloined several clocks which were in the various departments of the factory. The burglars gained entrance to the mill by

breaking the glass and parting bar of a window on the ground floor, just east of the entrance to the office, and then went through the shop at will. No clue to the identity of the thieves has yet been found.

As regards the Biggins Silver Co., Wallingford, the work of erecting their manufactory is proceeding rapidly and it will be ready to receive the machinery by the 1st of June. Messrs. Rogers, Osborne and O'Hara, the Bridgeport stockholders, are reported to be financially able to furnish the

capital required. Although they are unacquainted with silver manufacture they will find no difficulty in securing all the men they may need for the purpose of running the factory.

Henry K. Hotchkiss, one of the oldest of the retired business men of Ansonia, died of apoplexy last week at the residence of his son-in-law. Mr. Hotchkiss was born in Prospect. He learned the clock maker's trade and moved from Bristol to Ansonia in 1874 to take a contract with the Ansonia

**GOOD TIMES ARE COMING.**

Enliven your stock and set the ball rolling by putting in a line of the new "CHARMILLES" watch.

HIGHEST ART,

GREATEST VALUE,

LEAST MONEY.

FOR PARTICULARS AND PRICES ADDRESS YOUR JOBBER.

**Chrysanthemum.**

WE BEG TO ANNOUNCE THE EARLY APPEARANCE OF THE GREATEST EFFORT IN SPOONS AND FORKS, THE



**Chrysanthemum,**

(DESIGN PATENT PENDING).

FOR A YEAR THE MOST EXPERT DESIGNERS AND DIE-CUTTERS HAVE BEEN ENGAGED ON THE RICHEST AND MOST EXPENSIVE SPOON AND FORK DIES EVER PRODUCED. WE BELIEVE IT WILL BE TO YOUR ADVANTAGE TO INSPECT THE

**Chrysanthemum**

**WM. B. DURGIN,**

**CONCORD, N. H.**

PATTERN BEFORE RENEWING YOUR STOCK OF SILVER.

PATTERN IS NOW IN PROCESS OF ILLUSTRATION.



**DIAMONDS.**  
**Wm. S. Hedges & Co.,**  
 Importers of Diamonds,  
 And Manufacturers of DIAMOND JEWELRY,  
 170 Broadway, New York.  
 22 Holborn Viaduct, London.

**R. A. KIPLING,**  
 Importer of  
**PRECIOUS STONES,**  
 21 & 23 Maiden Lane,  
 19, RUE DROUOT, New York.  
 PARIS.

ONE YEAR'S SUBSCRIPTION  
 —TO—  
 The Jewelers' Circular  
 —At \$2.50,—

Entitles the subscriber to a copy of "WORKSHOP NOTES" free, a 200 page book, bound in cloth, containing a fund of information for the workshop that can be found in no other work.

**Alfred H. Smith & Co.,**  
 IMPORTERS  
**DIAMONDS**

AND  
**PRECIOUS STONES,**  
 182 BROADWAY, COR. JOHN STREET  
 NEW YORK.

33 Holborn Viaduct, London, E. C.

**STERN BROS. & CO.**  
 CUTTERS OF  
**DIAMONDS.**

WORKS: OFFICE,  
 29 & 31 Gold Street, AMSTERDAM, 30 MAIDEN LANE,  
 33 to 43 Gold Street, No. 2 TULPSTRAAT. NEW YORK.  
 NEW YORK.

**WM. SMITH & CO.,**  
 Manufacturers of Gold, Silver and Roll Plate Chains and Jewelry.



Novelties in Gold and Silver Bead Necklaces and Bracelets. Also a large line of Chain Trimmings and Silver Rings.

Office: 5 and 7 Maiden Lane, New York.      Factory: 61 Peck Street, Providence, R. I.

### Pittsburgh.

G. B. Barrett will visit Milwaukee this week.

Charles Italie, Braddock, is selling out at auction.

Oscar Ganter has removed from 5th Ave. to 443 Wood St.

Heeren Bros. & Co., last week, moved into their new building.

Ernest Siviter, of Wilkinsburg, is busy remodeling his storerooms.

Otto and William Heeren have returned from a business trip to New York.

I. Ollendorf left on Saturday last for New York, where he will locate permanently.

D. K. Lloyd, of Shaefer & Lloyd, will be found among the eastern visitors this week.

S. L. Ginsburg has gone into the jobbing business, and Leo Weil will probably represent him.

Ernest Blank has fitted up new quarters on Fifth Ave., near the old Market House, and has gone into business.

John Linnenbrink and Henry C. Lacock, Rochester, Pa., left last week for a trip to Los Angeles, San Diego, and the Mid-Winter Fair.

George L. West, of G. B. Barrett & Co., has returned from a trip through West Virginia and Ohio, and reports business improving slowly in most of the towns.

A landlord's warrant has closed out Henry Bucher, Fifth Ave. near Stevenson St. I. Ollendorf also has an account against Bucher which is said to be insured by Henry Terheyden.

Among the buyers here last week were: H. H. Weylman, Kittanning; H. Wallace, Smith's Ferry; J. W. Caylor, Beaver, Pa.; H. C. Morrison, Mt. Pleasant; John R. Griet, Butler; B. Neville, Dawson; and Mr. Scott, Braddock.

Samuel Harrowitz, the jeweler of Federal St., Allegheny, who has been on trial for receiving stolen goods from Annie Alexander, the noted shoplifter, received his sentence last Saturday. It was a fine of \$500 and costs to the prosecution.

A contribution of three cents per capita was given by all the jewelers in town and hereabouts, who visited Heckel, Bieler & Co. the past month for the payment of a bronze medal for Will Jones, one of the staff, who is an athlete of many battles and no victories. The medal bears the inscription, "He did his best."

### Rockford.

U. C. Osborne has returned from a trip through New Mexico, Arizona and to the coast. He reports trade dull.

At the annual meeting of the stockholders of the Rockford Watch Co. J. S. Ticknor, Peter Somes and Irvin French were re-elected directors for three years.



**Fashions in Jewelry and Silver-ware.**

A LADY'S RAMBLES AMONG THE JEWELERS.

The new silver toast racks indicate that toast is in fashion.

Mustard pots of red glass set in perforated silver with a silver cover are new.

There seems to be an increase in the use of different tinted gold for working out designs.

A crescent brooch, fully four inches long from end to end, is of graduated smoky topazes set with small brilliants.

Intaglios of sard set in gold are used as double link sleeve buttons by people of artistic and quiet tastes.

New tiaras are built like crowns. The centers are at least four inches high. Talk about American queens!

An ornament is a bursting sun of diamonds around a cat's-eye, two inches in diameter. In and out of the tips of the sun rays is a green enameled snake.

New letter racks have been produced made of grade 1 circles in raised work mounted on an inclined standard and supported like a photograph frame.

A bodice decoration is a rose garland of diamonds that passes around the waist and is fastened with a rosette of diamonds, the center of which is a huge aquamarine with diamond pendants.

Harness is the very word that describes some of the decorations for bodices. One such is made of fine dead gold chains strung together brace fashion with cross pieces. All the points of intersection are fastened by huge pearls.

Worth, the modiste, has introduced a new ornament in jewelry, which bids fair to be a favorite. It is a diamond triangle, with a flower or monogram in the centre, and may be worn as a buckle, a brooch, or a decoration for the hair.

Convenient and pretty receptacles have been brought out for holding the matutinal orange. They are on a low standard, tip tilted, polished with a raised and broken edge, and have a rack at the back for supporting the pointed spoon.

Colored stones were never more used. Large oval blocks of aquamarine and smoked topazes are preferred. These are set in the high tiaras, in decorations for bodices, in girdles, sumptuously set with diamonds and gold and silver.

A breast knot is an aquamarine, in which is a design of gold set with rubies. This is surrounded by cunningly worked mountings in dead gold. From below hangs graduated bars of gold made in segments set with aquamarine and connected by short curving bars with rubies. The ornament terminates in a single aquamarine about 8 inches from the start.

ELSIE BEE.

ESTABLISHED 50 YEARS.

**RANDEL, BAREMORE & BILLINGS,**

IMPORTERS OF

**DIAMONDS,**

AND OTHER PRECIOUS STONES.

**FINE PEARLS A SPECIALTY.**

MANUFACTURERS OF

**DIAMOND JEWELRY,**

IN THE LATEST DESIGNS.

Diamonds Recut in Modern Styles or Repaired on Premises.

58 Nassau Street,  
29 Maiden Lane  
NEW YORK.

1 Tulp Straat,  
AMSTERDAM.

1 St. Andrews St.,  
Holborn Circus,  
LONDON, E. C.



TRADE MARK.

ESTABLISHED 1841.

**CARTER, SLOAN & CO.,**

**MANUFACTURERS OF GOLD JEWELRY,**

No 15 MAIDEN LANE.

NEW YORK.

A. CARTER, JR.  
A. K. SLOAN.  
C. E. HASTINGS.

GEO. R. HOWE.  
WM. T. CARTER.  
WM. T. GOUGH.

FACTORY, NEWARK, N. J.



**JOHN N. DISSELKOEN,**

Cutter and Importer of

**DIAMONDS**

FACTORY.  
79 LANGBLEEKERSPAD  
AMSTERDAM.

19 East 16th St.,  
NEW YORK.

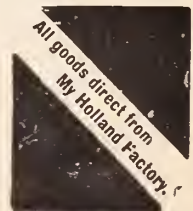



## SUGGESTIONS FOR WINDOW AND STORE DECORATION.

Members of the trade who think they have an attractive window are invited to send us a photograph, or a pen and ink or pencil sketch of the same, which will be published if we consider the window contains any originality or lesson.

### IDEA LXX.

**A.** E. SEIFERT, the well-known jeweler of Quebec, Can., has designed an original window decoration that is particularly effective during the long dark days of Winter. In his own words, the details of this design are as follows:

"Take a cask such as is used by electro-plate shippers; knock both ends out, line

the window was an Easter egg made of white cotton and adorned with roses and jewelry, arranged in curved rows around the egg. At each end of the window a piece of white cotton was arranged in circular form with a large brilliant jewel in the center. The whole window was trimmed with miniature red roses.



ELECTRIC LIGHTS EFFECTIVELY EMPLOYED.

the cask neatly with black velveteen. The part of the cask on which the goods are to be displayed should be padded for the better display of diamond jewelry.

"Take also two boxes of suitable size; take back end out of both and cut an arch in the front end; line the boxes with material to suit the class of goods to be displayed. Drape the front with plush. Introduce electric light inside the cask and boxes. Cover the whole in dark material, including the back end of each box. Have no lights in the window except those in the cask and boxes.

"The advantages of this display: inexpensiveness and effectiveness."

### Two Unique Easter Windows in Louisville.

**G.** E. W. PLINKE had a unique window display for Easter, and it attracted considerable attention. In the center of

L. Huber also had an attractive Easter window. The principal design was a large bell, made of white cotton, with proportionate clapper. The whole hung in the centre of the window, with streamers of ribbon running off to each corner. On the side of the bell were stuck in the cotton some very brilliant gems and other jewelry, arranged tastily, with blue violets dotting the background of the snow white.

### The Brilliant Easter Windows of J. E. Caldwell & Co.

**N**EVER before has the art of window decoration—for it is an art—been more strikingly illustrated than it is at present in the great display windows of James E. Caldwell & Co., Chestnut St., above 9th. The arrangement in both is novel in design, artistic in effect, and color, shape and taste

No jeweler or watch repairer should be without a copy of "WORKSHOP NOTES," a new and very useful book for the workshop. Send for circular containing a complete index of the book, and judge of its merits for yourself.

are most beautifully blended. The east window is particularly brilliant in its decorations. The prominent feature is a statue of Flora, the goddess of flowers, 9 feet high, and of purest Carrara marble. It is the work of the celebrated Florentine sculptor, Lapini. The modeling is perfect, the pose delightfully buoyant and the face beaming with a joyous smile. The attitude of the goddess indicates that she is tripping merrily over the earth, while at her feet a cluster of beautiful flowers seem to pour out their votive offering of incense. Behind the goddess is placed a mirror beautifully framed in gilt. A large mirror is placed at her side, before which stand exquisite sconces filled with candles of purest wax. Several pots of palms are placed in the rear of the goddess on each side. Electroliers of 30 pink lights, decorated in pink silks and Swiss mull, give a charming and brilliant effect.—*Philadelphia Record.*

## Points of Law.

### WHAT CONSTITUTES HOMESTEAD.

An owner of a life estate in lands occupied by him as a family residence, who has conveyed his interest to a creditor with an agreement for a reconveyance upon the payment of a debt, is the owner of a homestead, within the meaning of a statute, and is therefore not entitled to claim the exemption of personal property.

*Biddinger v. Pratt, Supreme Court of O.*

### WHAT CONSTITUTES POSSESSION BY ASSIGNEE.

Immediately after the execution of an assignment for the benefit of creditors, possession was taken by the assignee, the property was advertised for sale at auction, and in the interval of eight or ten days, the assignee, assisted by the assignor, sold some of the property at private sale, but the assignor exercised no control whatever over the property. *Held*, that immediate possession of the assigned property was taken and held by the assignee.

*Rider v. Duffy, Supreme Court, General Term, Second Department.*

Oh, what authority and show of truth can cunning sin cover itself withal.—*Shakespeare.*

## FOR JEWELERS' USE.

G. A. Kleemann's Patent Improved Student Lamp.

C. A. Trade Mark.

**THE GERMAN AMERICAN.**  
It preserves all the improvements which have made the St. Germain Student Lamp so acceptable to Watchmakers and Mechanical Jewelers, but is a much larger lamp, fitted with a nine-inch shade and its new large burner—far superior to that of the St. Germain—gives a light nearly double in brilliancy.

Steady white light, perfect combustion, without much heat, safe against explosion.

Will last a lifetime. Wick easily adjusted. Illustrated circular free.

**HINRICHS & CO.,**  
29, 31 & 33 PARK PLACE,  
NEW YORK CITY.



**REMOVAL!**

**L. BLACK & CO.**  
178 BROADWAY,

WILL REMOVE IN APRIL TO THEIR FACTORY,  
**DETROIT, MICHIGAN.**



**Revised Tariff of the Canadian Government.**

MONTREAL, Can., March 31.—The Canadian Government in framing the new tariff bill made little change in respect to jewelry, watches, etc. An effort was made by a few retailers to have the duty on watch cases reduced, but the objection to this was so strong that it was allowed to remain as it was, namely, 35 per cent.

The following shows the present tariff and changes:

Gold, silver and jewelry, composition metal for the manufacture of filled gold watch cases, 10 per cent. ad valorem. Old rate, the same.

Britannia metal and German and nickel silver manufactures of, not plated, 25 per cent. Old rate, the same.

Nickel anodes, 10 per cent. Old rate, the same.

Gold and silver leaf, and Dutch or schlag metal leaf, 25 per cent. Old rate, 30 per cent.

Manufactures of gold and silver and all other articles not elsewhere specified, commercially known as jewelry, new, 25 per cent. Old rate, 20 per cent.

Sterling silver tableware and plated ware, all other electric plated or gilt, of all kinds, whether plated wholly or in part, 30 per cent. Old rate, 30 per cent.

Plated cutlery, namely, knives, plated wholly or in part, 35 per cent. Old, 50 cents dozen and 20 per cent.

Precious stones, polished, but not set or otherwise manufactured and imitations thereof, 10 per cent. Old rate, the same.

Clocks, 25 per cent. Old rate, 35 per cent.

Tower clocks, 30 per cent. Old rate, 35 per cent.

Watches, 25 per cent. Old rate, the same.

Watch actions or movements, 10 per cent. ad valorem. Old rate, the same.

Watch cases, 35 per cent. Old rate, the same.

Cases for jewels and watches, cases for silver and plated ware and for cutlery and other like articles, writing desks, glove boxes, handkerchief boxes, manicure cases, perfume cases, toilet cases and fancy cases for smokers' sets and similar fancy articles made of bone, shell, horn, ivory, wood, leather, plush, satin, silk, satinette, or paper; dolls and toys of all kinds, including sewing machines, when not of more than two dollars in value, ornaments of alabaster, spar, amber, terra cotta or composition, and statuettes and bead ornaments, 35 per cent. ad valorem. Old rate, 10 cents each and 30 per cent.

**E. W. Blue Gives Mortgages to the Extent of \$19,000.**

ATLANTA, Ga., March 29.—Over \$19,000 in mortgages have been given by E. W. Blue on his stock of goods. The following are the mortgages as recorded: to Mrs. Clara Ellen Blue, \$10,150; to Albert Bros., \$2,500; John W. Cox, \$2,700; J. T. Wylie,

\$500; Rowena Peyton, \$400; Heller & Bardel, \$1,322.52; Ben Spiers & Co., \$1,458.49.

Walter R. Brown, attorney for creditors, has filed a bill asking for a receiver. In the meantime a temporary injunction will restrain Mr. Blue from disposing of any of the stock.

Mr. Blue's liabilities are estimated at about \$40,000 and his assets at \$30,000.

**Philadelphia.**

J. M. Harper visited several eastern manufacturing last week.

Jas. H. Orbell, of Juniata St., has recovered from a serious illness.

J. Albert Caldwell has been elected a vestryman of St. Stephen's Church.

The effects of J. Rosendale were sold by auction on Saturday last, and realized \$3,111.50.

Harry Schimpf and Jules Levy will be the tellers at the Scherr horse raffle for the relief of the poor at the New York Jewelers' Exchange, on Saturday evening next. Quite a number of interested jewelers expect to run over to New York for the "drawing."

The jewelry store of Jas. Ettleson, 714 S. Front St., was broken into on Saturday morning last, by a couple of thieves, who were discovered and promptly arrested. They gave their names as Edward Maher and Wm. Ryan, and Magistrate Kane committed them for trial on the charge of burglary, goods to the value of \$10 having been secured by them.

**Springfield, Mass.**

L. S. Stowe, of L. S. Stowe & Co., has been elected vice-president of the Springfield Improvement Association.

Springfield was visited by the following jewelry men during the past week: J. H. Thompson, Bioren Bros.; Mr. Swett, J. C. Sawyer & Co.; E. Kubie, Imperial Optical Co.; F. R. Hollister, G. E. Luther & Co.; W. T. Weeks, C. G. Alford & Co.; Arthur A. Wheeler, Gorham Mfg. Co.

A circular letter has been received in this city from the Pinkerton Detective Agency, offering a reward of \$200 for the capture of H. C. Boyd, the thief who relieved H. C. Barnum of his trunk in this city last January. Shafer & Douglas estimate that they lost 254 rings of the aggregate value of \$4,000, by the steal.

**Meeting of the Creditors of W. A. Graham.**

BOSTON, Mass., March 30.—A meeting of the creditors of W. A. Graham, Marlboro, Mass., doing business as W. A. Graham & Co., was held to-day at the Parker House. A. T. Sylvester, of H. T. Spear & Son, was chairman, and G. H. Herrick, of Attleboro, was secretary.

From the debtor's statement submitted by his attorney it appeared that his liabilities were about \$3,800, some \$2,000 for mer-

chandise and the balance borrowed money. Assets, consisting of stock and fixtures, were appraised by Mr. Graham at \$1,400.

The assignees, E. A. Whitney, of Boston, and M. Quirk, of Marlboro, had no statement to present, as the store has been closed and they feared to open it, the sheriff having several attachments which he wished to serve if the doors were opened.

The prospective dividend promises to be small. It was the opinion of the meeting that the matter should be settled in the insolvency court, and steps have been taken to wind up the business.



**\$4.50**  
**Per Dozen.**

**Sterling Silver "TROLLEY" or Hat Guard for Straw Hats, unlimited Sale THIS YEAR. Gold and Silver Art Match Boxes, Diamond and Half Pearl Brooches, Swords and Scarf Pins. Repairing a Specialty.**

**CLARENCE W. SEDGWICK,**  
11 EAST 20th ST., - NEW YORK.

**MARTIN BRUNOR & SON,**  
**Electroplaters,**

**Expert work done on Solutions and Chemicals when desired.**

**POLISHER AND LAPPER OF FINE JEWELRY FOR THE TRADE.**

Send your goods, such as Gold and Silver Plating, and mention the price you want to spend.

**SEND FOR PRICE LIST.**

Also do all kinds of repairing in the Jewelry and Watch Case line.

Don't forget we removed from 32 Maiden Lane to

**93, 95 & 97 WILLIAM STREET.**



## Our Traveling Representatives



Traveling representatives may consider these columns open for the publication of any news or items of interest regarding themselves or their confreres.

**G. D. LUNT** returned Saturday from his California trip for the Towle Mfg. Co. California was especially good in a business way with other parts of the coast quiet. Souvenir spoons are good sellers and the Mid-Winter Fair has generally helped silver lines.

Frank Muhr, the representative in charge of H. Muhr's Sons' World's Fair Exhibit, passed through Chicago Saturday on his way to the Pacific coast.

W. B. Bynner, for J. B. Bynner; M. Lissauer, W. L. Pollack & Co.; K. Marx, Kosuth Marx Jewelry Co., and B. F. Levy were in Lynchburg, Va., the past week. All reported business looking up and all sold nice bills there.

Traveling men in Boston, Mass., the past week included: Eugene H. Cox, Sussfeld, Lorsch & Co.; H. Guntberger, C. Cottier & Son, S. O. Bigney, Marsh & Bigney, G. Strandberg, E. L. Spencer & Co.; J. M. Fisher; B. W. Greene, Greene & Knox Mfg. Co.; George T. Paine, E. I. Franklin & Co.

Traveling men calling on Davenport, Ia., jewelers the past week were: J. L. Herzog, Louis Kaufman & Co.; Henry H. Jacobson, Jacobson Bros.; Steven Smith, Henry Williams & Co.; C. E. Patterson, Towle Mfg. Co.; M. Hoefer, M. A. Mead & Co.; W. S. Willis, Gorham Mfg. Co.; Leslie Mullen, Herman Keck Mfg. Co.; J. M. Stanley, Jr., Meriden Silver Plate Co.

The traveling community was represented in Philadelphia, Pa., last week, by Benj. Schloss, A. Wallach & Co.; A. Nordlinger, L. & M. Kahn & Co.; G. C. Hudson, H. F. Barrows & Co.; H. Granbery, Reeves & Sillocks; Harry K. Ingraham, Alling & Co.; M. Adler, B. L. Strasburger & Co., C. Osborne, Wm. Smith & Co.; J. Williams, G. Armenty, and Lewis P. Cook, J. F. Fradley & Co.

Traveling men seen in Indianapolis last week included: Mr. Breslau, Stone Bros.; V. B. Burgesser, Kremenz & Co.; W. M. Pyle, Dueber Watch Case Mfg. Co.; Fred. C. Somers, Marsh & Bigney; J. T. Inman, Inman & Co.; Robert Moorhead, R. L. Moorhead & Co.; F. N. Vaslett, Fletcher, Burrows & Co.; J. S. Platt, Foster & Bailey; and representatives of Seth Thomas Clock Co., St. Louis Silver Plate Co. and Dueber-Hampden Co.

Among the traveling men in Lancaster, Pa., the past week were: E. Jacobson, Jacobson Bros.; John W. Sherwood; R. H. Schwarzkopf, Bippart & Co.; Mr. Smith,

Kent & Stanley Co.; L. D. Reynolds, J. B. Bowden & Co.; S. Aronsberg, John Scheidig & Co.; Henry Bodenheimer, Fink, Bodenheimer & Co.; F. W. Sackett; C. F. Duffy, Enos Richardson & Co.; R. W. Simpson, Jr., Riker Bros.; Theo. M. Woodland, Larter, Elcox & Co.; Mr. Hart, Mt. Washington Glass Co.; A. H. Vorster, L. Straus & S. ns.

Traveling men in Pittsburgh last week were: Mr. Abel, Lewis, Kaiser & Luthy; Will Miller, Seth Thomas Clock Co.; D. O. Skutch, Waterbury Clock Co.; T. H. B. Davis, Middletown Plate Co.; Fred Heffron, Riley, French & Heffron; Maj. Brooks, Brooks & Pike; Jake Adler, L. & J. Adler & Co.; Mr. Engelsman, Maurice Weil; Eddie Todd, Ed. Todd & Co.; A. Kiersky, Kraus, Kragel & Kiersky; George T. Bynner, Wymble Mfg. Co.; Mr. Pickering, Shoemaker, Pickering & Co.; Mr. Shute, Day & Clark; G. W. Mindil, American Watch Case Co.; Leopold Laubheim, Adolph Goldsmith & Son; S. W. Abbey, E. Ira Richards & Co.; and G. F. Kaiser, Enos Richardson & Co.

Traveling men in Chicago last week included: Mr. Oakley, Thornton Bros.; Ernest Block, W. & S. Blackinton; C. L. Joralemon, A. Joralemon & Co.; L. H. Bosworth, Potter & Buffinton; Mr. Van Houten, Sinnock & Sherrill; Frank B. Lawton, S. B. Champlin & Son; C. F. Willemin, H. Muhr's Sons; representative of W. E. Webster; R. A. Thompson, Henry Glorieux; A. Peabody; Wm. Rosenberger, A. Wallach & Co.; Walter Shute, Day & Clark; A. Barker Snow; G. F. Kaiser, Enos Richardson & Co.; John Platt, Foster & Bailey; Monroe Engelsman, Maurice Weil; Mr. Stern, Young & Stern; C. H. Coggsill, Geo. L. Vose & Co.; Wm. W. Middlebrook, B. A. Ballou; Max Potter, C. R. Harris & Co.; R. L. Moorhead; Jim Peacock.

### NOT LIABLE FOR THE DESTRUCTION OF SAMPLE TRUNKS.

CINCINNATI, O., March 31.—Judge Hunt has allowed the motion for a new trial in the case of the Greenwich Insurance Co. against the Memphis & Cincinnati Packet Co. The decision is of great interest and importance to traveling salesmen and business firms who employ them, as well as to railroads and steamboat lines. In January, 1890, the steamer *De Sota* was burned on the Ohio River between Owensboro and Henderson, Ky. Among the property destroyed was a drummer's sample trunk, containing goods valued at \$2,500. The trunk and contents had been insured in the Greenwich Insurance Co. The latter company made good the loss, but in turn sued the Memphis & Cincinnati Packet Co. on the ground that the fire was due to gross negligence.

The insurance company got a verdict against the steamboat company, but a motion for a new trial was filed. In passing on the motion Judge Hunt held that a common carrier such as the steamboat company

agrees to carry only passengers' personal baggage without extra compensation. Personal baggage does not include samples of goods or goods that are for sale. The carrier, in the absence of gross negligence, is not liable for the loss of anything but the passenger's personal baggage, nor is the common carrier obligated to inquire into the contents of any trunk or package designated as baggage. It is the duty of the passenger to designate the nature of the contents of the package, and if the carrier agrees to carry it as such without extra compensation the carrier is liable for its loss or damage.

Among the traveling representatives abroad in Syracuse, N. Y., the past week were: C. S. Griswold, Middletown Plate Co.; Mr. Bride, S. Cottle Co.; V. W. Henderson, Enos Richardson & Co.; Chas. W. Brown, C. Rogers & Bros.; James A. Cheney, Ludwig Nissen & Co.; W. H. Bryant, T. G. Hawkes & Co.; J. T. Inman, J. T. Inman & Co.; P. R. Ketcham, Brooklyn Watch Case Co.; A. N. Dorchester, Kent & Stanley Co.; Edwin P. Hutten, Geoffroy & Co.; Josh Mayer, Powers & Mayer; E. A. Crawford, T. I. Smith & Co.; Mr. Simons, Stern Bros. & Co.; Leon Schwab, New Haven Clock Co.; A. Webster, American Watch Tool Co.; Mr. Neefus, E. N. Welch Mfg. Co.; L. M. Levy, Adolphe Schwob; E. L. Spencer, E. L. Spencer & Co.; W. P. Talbot; C. A. Keene; Maurice Rosenbaum, B. H. Davis & Co.; W. F. Lawrence, Spencer Optical Mfg. Co.; R. H. Harris, Ansonia Clock Co.; Mr. Smith, Smith & Knapp; Wm. W. Middlebrook, B. A. Ballou & Co.; J. M. McClanin, E. A. Robinson; Maj. Brooks, Brooks & Pike; W. R. Eljot, J. D. Bergen Co.; M. C. Wells, Pierce & Gardiner; L. A. Van Horn, Philipp Zellenka & Son.

### The Sheriff in Possession of the Store of T. V. Dickinson.

BUFFALO, N. Y., March 28.—T. V. Dickinson, one of the leading jewelers of this city, was closed out by the sheriff this morning. His chief creditors are the Queen City Bank, \$6,186; Ludwig Nissen & Co., New York, \$3,000; Sarah A. Burtis, Buffalo, \$4,000; Charles D. Marshall, \$2,930; German American Bank, \$1,523.

Mr. Dickinson started in business about 11 years ago. He had been formerly employed by T. & E. Dickinson, in which his father was senior partner. He had a small branch store at Niagara Falls. A short time ago he asked and received an extension on the following basis: Instalments of 5 per cent. each, payable in May, August, October and December, 1894; 10 per cent. each in January and February, 1895; 5 per cent. each in April, June, August, October and December, 1895; 10 per cent. each in January and February, 1896, and 5 per cent. each in March, May and July, 1896. A. K. Sloan, of Carter, Sloan & Co., and Ludwig Nissen, of Ludwig Nissen & Co., were appointed trustees for the creditors.



**News Gleanings.**

George Davis will open a jewelry store in Gaines, Pa.

George W. Fordyce, Anita, Ia., has opened a jewelry business.

Harris & Co., Wilkesbarre, Pa., have retired from the jewelry business.

The business of H. A. Barrett, Brockton, Mass., was damaged by fire last week.

Fred Witherstine will open a jewelry store in Herkimer, N. Y., about May 1.

Robert Albert, Oneida, N. Y., was in Syracuse, N. Y., buying goods last week.

Rudy Krull, jeweler, Ft. Wayne, Ind., has accepted the agency for the Warwick bicycles.

F. C. Kramer, Carlisle, Pa., announces that he has decided to sell his entire stock at auction.

The business of the "Hole in the Wall" jewelry store, Denver, Col., was damaged by fire last week.

W. H. Williams & Son, 12 N. Pearl St., Albany, N. Y., will continue business at their present location.

A. L. Campbell, jeweler, Lansford, Pa., will be a candidate for the Republican nomination for sheriff.

J. Z. Simpson, Morgantown, W. Va., will dispose of his jewelry store and return to his Pennsylvania home.

Lewis J. Henise, jeweler, York, Pa., has just completed an electro-plating shop in connection with his business.

Thos. Buchanan, watchmaker and jeweler, Shenandoah, Pa., has removed his jewelry store to 212 S. Main St.

W. F. Main, Iowa City, Ia., has purchased two lots on Summit St. for \$1,200. Two residences will be erected thereon.

A. Stevens, Rockland, Me., has rented

the store in Wood's block, Exeter, N. H., and intends fitting it up immediately.

The death occurred a few days ago of George C. Van Sickell, jewelry engraver, Trenton, N. J. He was 44 years of age.

H. M. Rich & Co., Boston, Mass., are conducting an auction sale for C. J. Welty, Carlisle, Pa., prior to his removal to his new room.

The building in which is located the business of W. R. Hulburt, South Framingham, Mass., was destroyed by fire Wednesday morning last.

P. Howard Wertz, Lancaster, Pa., formally opened his new store at 116 N. Queen St., on March 31. His line of diamonds, watches and silverware is very complete.

George J. Watson, senior member of Watson & Son, jewelers, Perry, N. Y., fell dead a few days ago. Death is supposed to have been due to heart disease. He was a man of advanced years.

The death occurred last week of Amable M. Lapierre, father of Ed. M. Lapierre, jeweler, Niles, O. Deceased was one of the pioneer residents of South Bend, Ind., and was 79 years of age.

Christopher Myers, Wm. Dalton and John Burns have been acquitted of breaking the show window of the jewelry store of G. T. Sadler & Sons, Baltimore, Md., and stealing spectacles, etc., valued at over \$300. The robbery was committed between 6.30 and 10.30 P.M., March 10th.

A landmark in Baltimore, Md., that has disappeared is the jewelry store of Gabriel D. Clarke, on S. Calvert St., corner of German. Men are at work inside the building making changes, and Mr. Clarke is sometimes to be seen within sitting in a chair and watching them. He has retired from business.

**Julius A. Lebkuecher, Newark's Republican Candidate for Mayor.**

NEWARK, N. J., March 28.—The Republican agitation to nominate Julius A. Lebkuecher, of Krementz & Co., for Mayor, has reported in last week's CIRCULAR, has resulted favorably to the gentleman. Not in ten years have Republican prospects of success been so bright and as a consequence many candidates appeared. The names of fourteen prominent citizens were placed before the convention and in the van was that of Dr. H. C. H. Herold, who up to the eighth and final ballot was considered the favorite.

But just at the last moment, and when victory for the doctor appeared sure, his opponents combined forces, and by throwing their united strength in favor of Julius A. Lebkuecher, landed him a winner on the eighth formal ballot, with 123 votes, while Dr. Herold stood second, with 37—nineteen less than the number necessary to a choice.

Julius A. Lebkuecher is a member of the firm of Krementz & Co. He entered the employ of the firm twenty-three years ago, and by ability rose to his present position. He is a lifelong resident of the old 14th ward of Newark and has always been an uncompromising Republican. Mr. Lebkuecher is a representative citizen and the strongest kind of a candidate for the people.

The "Chrysanthemum," the new fork and spoon pattern, now being announced by Wm. B. Durgin, Concord, N. H., is, it is said, the finest design ever produced. For over a year expert designers and die cutters have been working steadily toward the perfection of the "Chrysanthemum" and their labors are about completed. The pattern is now in process of illustration and will shortly appear in these pages. It will certainly pay everyone to inspect the "Chrysanthemum" before renewing silver stocks.

**R** **EMOVAL** **I. OLLENDORFF,**  
**FROM** **IMPORTER OF**  
**Pittsburgh** **DIAMONDS, AND**  
**TO** **JOBBER IN WATCHES,**  
**NEW YORK.** **JEWELRY, CLOCKS**  
**AND SILVERWARE,**  
**45 MAIDEN LANE,**  
**NEW YORK.**



# CLASSIFIED INDEX TO ADVERTISEMENTS.

All Advertisements are entitled to one insertion under proper heading. Extra insertions, \$6.00 per annum.  
Extra Headings, \$12.00 per annum.

	Page.		Page.		Page
<b>Art Pottery, Bric-a-brac, Etc.</b>		<b>Gold Jewelry.</b>		<b>Ring Makers.</b>	
Ahrenfeldt, Charles & Son, 50-52-54 Murray St., N. Y.....	38	Carter, Sloan & Co., 15 Maiden Lane, N. Y. . .	27	Bryant, M. B. & Co., 10 Maiden Lane, N. Y. . .	37
Bing, Ferdinand & Co., 106 Grand St., N. Y. . .	38	Johnson R. M., 67 Washington St., Chicago, Ill.	20	Bowden, J. B. & Co., 192 Broadway, N. Y. . . . .	7
Hinrichs & Co., 29 & 31 Park Place, N. Y. . . . .	41	Kremetz & Co., 182 Broadway, N. Y. . . . .	2	Wood, J. R. & Sons, New York. . . . .	41
Straus, L. & Sons, 42 to 48 Warren St., N. Y. . .	37	Pfeil, Chas. H., Chicago, Ill. . . . .	21		
		Reddall, Jno. W. & E., 107 Hamilton St., Newark, N. J. . . . .	9	<b>Sample Trunks.</b>	
<b>Assayers &amp; Refiners.</b>		Schwartz, W. H., & Co., Newark, N. J. . . . .	7	Crouch & Fitzgerald, 161 Broadway, N. . . . .	5
Baker, Geo. M., Providence, R. I. . . . .	36	Smith, Wm., & Co., 5-7 Maiden Lane, N. Y. . . .	26		
Clark, J. L., Philadelphia, Pa. . . . .	37	Unger Bros., 192 Broadway, N. Y. . . . .	12	<b>Silver Mounted Ebony Goods.</b>	
Goldsmith Bros., 63 & 65 Washington St., Chicago, Ill. . . . .	19	Webster, G. A., Chicago, Ill. . . . .	41	Deutsch Bros., 7 E. 17th St., N. Y. . . . .	2
Howard, S. P., 33 Maiden Lane, N. Y. . . . .	44				
Le Long, L. & Bro., Newark, N. J. . . . .	44	<b>Horological Schools.</b>		<b>Silver Plated Ware.</b>	
Rathbone, J., Providence, R. I. . . . .	4	American Horological Institute, Lancaster, Pa.	22	Pairpoint Mfg. Co., New Bedford, Mass. . . . .	5
Schawel, J. & Co., 29 John St., N. Y. . . . .	44	Chicago Watchmakers' Institute, Chicago, Ill.	20	Rogers, Smith & Co., Meriden, Conn. . . . .	15
		Elgin Horological School, Elgin, Ill. . . . .	21		
<b>Auctioneers.</b>		Parson's School for Watchmakers, Peoria, Ill.	21	<b>Sterling Silver Novelties.</b>	
American Syndicate of Jewelers' Auctioneers, New York and Washington. . . . .	2	Philadelphia College of Horology, 623 Heed Building, Phila., Pa. . . . .	41	Codding Bros. & Heilborn, North Attleboro Mass. . . . .	42
French, J. H., P. O. Box 2775, N. Y. . . . .	7			Sedgwick, Clarence W., 11 E. 20th St., N. Y. . .	29
Lusk, G. W., 501 Masonic Temple, Chicago, Ills. . . . .	21	<b>Hotels.</b>			
Prince, J., 137 Broadway, N. Y. . . . .	44	Gibson House, Cincinnati, O. . . . .	22	<b>Sterling Silverware.</b>	
Rich, H. M. & Co., Boston, Mass. . . . .	38			Campbell-Metcalf Silver Co., Providence, R. I. .	2
Scott, De B. O., 20 Murray St., N. Y. . . . .	41	<b>Jewelers' Findings.</b>		Durgin, Wm. B., Concord, N. H. . . . .	25
		Lind, Thos. W., Providence, R. I. . . . .	42	Reed & Barton, 37 Union Square, N. Y. . . . .	20
<b>Badges, Medals, Etc.</b>				Shiebler, Geo. W., Co., 179 Broadway, N. Y. . .	4
Irons & Russell, Providence, R. I. . . . .	37	<b>Jewelers' Lamps.</b>		Towle Mfg. Co., Newburyport, Mass. . . . .	41
Stockwell, E. R., 19 John St. N. Y. . . . .	28	Hinrichs & Co., 31 Park Place, N. Y. . . . .	28	Wallace, R. & Sons Mfg. Co., 3 Park Place, . . .	6
				Whiting, F. M. & Co., North Attleboro, Mass. .	8
<b>Chronometers.</b>		<b>Jewelry, Silverware and Optical Cases.</b>		Wood & Hughes, 16 John St., N. Y. . . . .	37
Bliss, John & Co., 129 Front St., N. Y. . . . .	43	Hebbard & Bro., 860 Broadway, N. Y. . . . .	43	<b>Spectacle and Eyeglass Cases.</b>	
				Birmingham, Wm. & Co., 728 Arch St., Phila..	44
<b>Clocks, French, English and American.</b>		<b>Jobbers, Watches, Diamonds, Etc.</b>		White, W. B. & Son, Boston, Mass. . . . .	4
Jacques, Chas., Clock Co., 22 Cortlandt St., N. Y. . . . .	44	Allen, Benj. & Co., Chicago, Ill. . . . .	23	<b>Stem Winding Attachments.</b>	
		Brethauer Watch and Jewelry Co., Chicago, Ill.	20	Abbott, Henry, 2 Maiden Lane, N. Y. . . . .	41
<b>Cut Glass.</b>		Cross & Beguelin, 17 Maiden Lane, N. Y. . . . .	2		
Mt. Washington Glass Co., New Bedford, Mass. . . . .	38	Friedlander, R., L. & M., 65, 67 Nassau St., N. Y. . . . .	24	<b>Thimbles.</b>	
		Myers, S. F. & Co., 48 Maiden Lane, N. Y. . . .	44	Ketchum & McDougal, 198 Broadway, N. Y. . .	41
<b>Diamond &amp; Precious Stone Importers.</b>		Ollendorff, I., 45 Maiden Lane, N. Y. . . . .	31		
Disselkoen, John N., 19 E. 16th St., N. Y. . .	27	Oppenheimer Bros. & Veith, 35 Maiden Lane, N. Y. . . . .	36	<b>Tissue Paper.</b>	
Falkenau, Oppenheimer & Co., 40 Maiden Lane, N. Y. . . . .	44			Dexter, C. H., & Sons, Windsor Locks, Conn. .	43
Fera, Henry, 10 Maiden Lane, N. Y. . . . .	44	<b>Leather and Silver Goods.</b>		<b>Tortoise Shell Goods.</b>	
Hedges, Wm. S. & Co., 170 Broadway, N. Y. . .	26	Deutsch Bros., 7 E. 17th St., N. Y. . . . .	2	Potter, W. K., Providence, R. I. . . . .	5
Kipling, E. E., 182 Broadway, N. Y. . . . .	44			<b>Tool Manufacturers and Dealers.</b>	
Kipling, R. A., Hays Bldg., N. Y. . . . .	26	<b>Musical Boxes.</b>		American Watch Tool Co., Waltham, Mass. . .	37
Lorsch, Albert & Co., 37 Maiden Lane, N. Y. .	44	Jacot & Son, 39 Union Square, N. Y. . . . .	2	Bullock, O. W. & Co., Springfield, Mass. . . . .	4
Randel, Baremore & Billings, 29 Maiden Lane	27			Hardinge Bros., Chicago, Ill. . . . .	20
Rothschild, M. D., 41 & 43 Maiden Lane, N. Y. .	44	<b>Office Furniture.</b>		Logan, A. J., Waltham, Mass. . . . .	5
Smith, Alfred H. & Co., 182 Broadway, N. Y. .	26	Schwartzwelder & Co., New York. . . . .	7	Moseley & Co., Elgin, Ill. . . . .	22
Stern Bros. & Co., 30 Maiden Lane, N. Y. . . .	26			Oliver, W. W., Buffalo, N. Y. . . . .	22
Tannenbaum, L., & Co., cor. Maiden Lane and Nassau St., N. Y. . . . .	15	<b>Optical Goods.</b>		Waltham Watch Tool Co. . . . .	7
		Berger, Albert & Co., 47 Maiden Lane, N. Y. . .	7	<b>Trunks and Traveling Bags.</b>	
<b>Diamond Jewelry.</b>		Kirstein's, H. E., Sons Co., Rochester, N. Y. .	37	Crouch & Fitzgerald, 161 Broadway, N. Y. . . .	5
eanne, Paul, Bradley Bldg., N. Y. . . . .	4	McIntire & Ulmer, cor 8th and Sansom Sts., Philadelphia, Pa. . . . .	41		
Leonhardt & Curran, 44½ Maiden Lane, N. Y. .	37	Queen & Co., Philadelphia, Pa. . . . .	41	<b>Watch Manufacturers.</b>	
		Scheidig, John, 43 Maiden Lane, N. Y. . . . .	17	Charmilles Watch. . . . .	25
<b>Electroplaters.</b>		Spencer Optical Mfg. Co., 15 Maiden Lane, N. Y. .	42		
Brunor, Martin, & Son, 93, 95, 97 William St., N. Y. . . . .	29	<b>Optical Schools.</b>		<b>Watch Case Manufacturers.</b>	
		The Chicago Ophthalmic College, Chicago, Ill. .	22	American Watch Case Co., Corbin Building, New York. . . . .	44
<b>Fine Stationery.</b>		<b>Paneled Metal.</b>		<b>Watch Case Repairers</b>	
Parsons & Greene Co., 18 Murray St., N. Y. . .	5	Northrop, A. & Co., Pittsburgh, Pa. . . . .	41	The Planchamp & Becker Co., Chicago, Ill. . . .	20
				<b>Watchman's Clocks.</b>	
<b>Gold and Silver Plating Works.</b>		<b>Pens, Pencil Cases, Etc.</b>		Hausburg, O. E., 41 Maiden Lane, N. Y. . . . .	41
Bolstad Mfg. & Plating Co., Chicago, Ill. . . . .	21	The Boston Pen Co., Boston, Mass. . . . .	37		
				<b>Watch Importers.</b>	
<b>Gold and Rolled Plate Jewelry.</b>		<b>Patents.</b>		Hyde's, J. E., Sons, 22 Maiden Lane, N. Y. . .	43
Foster & Bailey, Providence, R. I. . . . .	3	Belt, C. T., Washington, D. C. . . . .	5		
Read, M. L. & Co., Providence, R. I. . . . .	4			<b>Watch Keys.</b>	
		<b>Platinum Importers.</b>		Clark, A. N., Plainville, Conn. . . . .	2
		Schawel, J. & Co., 29 John St., N. Y. . . . .	44		
				<b>Watch Repairers.</b>	
				Henry, Peter, Cincinnati, O. . . . .	22
				Muller, Hugo, Chicago, Ill. . . . .	21



## Special Notices.

Rates 75c. per insertion for notices not exceeding 5 lines (25 words); additional words 2 cents each. If answers are to be forwarded, postage stamps must be enclosed. Two insertions, 15 per cent. off; three insertions, 20 per cent. off; four insertions or more, 25 per cent. off. Payable strictly in advance. Display cards on this page will be charged at \$2.00 per inch for first insertion, subject to same discount as above for subsequent insertions.

Under the heading of **Situations Wanted** on this page advertisements will be inserted for **One Cent a Word**. This offer refers to **Situations Wanted only**. Payable strictly in advance. If answers are to be forwarded, postage must be enclosed.

## Situations Wanted.

Notices under this heading **ONLY** are charged at one cent a word, payable strictly in advance. If answer are to be forwarded, postage must be enclosed.

**WANTED, SITUATION**—Manager of a business for two years past. Do all branches of work—watchmaking, engraving, seal making, jobbing, selling, buying. Box 695, What Cheer, Ia.

**SITUATION WANTED** as watch and clock maker; also jewelry repairer; age 21; speaks English and German; good references. Address A. Guenther, 875 Sixth Ave., New York.

**SITUATION WANTED** by an A1 watchmaker jewelry jobber and engraver. Can repair repeaters, chronographs and all other fine watches; 16 year at the bench; good salesman; sober and reliable; good set of tools; A1 references. Address P. B. L., P. O. Box 412, Winchester, Ill.

**YOUNG MAN** wishes position as second watchmaker. Can do ordinary watch, clock and jewelry repairing. Has tools and is competent. Address R. B., care of THE JEWELERS' CIRCULAR.

**SITUATION WANTED** by a young man who has had three years' experience at watch, clock and jewelry repairing. First class references. Address P. O. Box 249, Castleton, N. Y.

**POSITION WANTED** in a retail jewelry store as salesman or at the bench. Five years' experience. Address F., care of THE JEWELERS' CIRCULAR.

**YOUNG MAN** wants position where he can learn the jewelers' trade. Good engraver; have samples. Good references, and industrious. Address Engraver, care of THE JEWELERS' CIRCULAR.

**SITUATION WANTED** by an expert English watchmaker of 17 years' experience. Good diamond moulder and plain engraver. A1 references. Willing to do jewelry work. Own tools. Address Expert, Box 134, San Marcial, New Mexico.

**POSITION WANTED** as traveling salesman with a silver plate, sterling or jewelry house; 12 years on road with silver plate; extensive acquaintance with trade; references. Address L. R. X., care of THE JEWELERS' CIRCULAR.

**SITUATION WANTED** as engraver and watchmaker with good house; have lathe, bench, tools, etc.; do all kinds of watchwork and engraving; pierced monograms and dies for stationery. Address Racso, care of THE JEWELERS' CIRCULAR.

**ENGRAVER, A1**. Lettering in all its branches. Monograms, ciphers and ornamental work. Also capable of doing copper plate and die cutting for stationery trade. Open for engagement after May 1st. Address J. J. M., care THE JEWELERS' CIRCULAR.

**A COMPETENT WATCHMAKER** would like a position; 18 years' experience on fine and complicated work; perfect set of tools. Address Curtis, care of THE JEWELERS' CIRCULAR.

**A1 OPTICIAN AND WATCHMAKER**. About May 1. Charge of optical department in jewelry or optical store, or go on the road. E. T. Smith, 109 Cedar St., Corning, N. Y.

**FIRST-CLASS** practical lapper and polisher wants position; used to all kinds of best diamond mountings; capable of taking charge of polishing department; would go anywhere for good position. Address Practical, Newark, N. J.

**WORK WANTED FOR JEWELERS, SILVERSMITHS, ENGRAVERS, DESIGNERS, WATCHMAKERS, CASEMAKERS, TOOLMAKERS, ETC. ONLY WORKMEN WITH GOOD TESTIMONIALS FROM PREVIOUS EMPLOYERS ARE RECOMMENDED.**

ADDRESS,  
**JEWELERS' RELIEF ASSOCIATION,**  
11 MAIDEN LANE, N. Y.

## Help Wanted.

**YOUNG MEN** desiring to learn watchmaking thoroughly, or to finish their trade, address for terms, A. Naundorf, 120 S. 7th St., Philadelphia, Pa.

**WANTED**.—Traveling salesmen in all parts of the United States to carry an illustrated pocket catalogue and price list of Grout's Excelsior Watch and Spec Signs and Watch Tools, Foot Wheels, Polishing Lathes, &c. for Jewelers' use. Big money as a side line. Can be carried in the pocket. Every traveler should carry it. Write for agency. Excelsior Sign and Mfg. Co.; L. S. Grout, Manager, 56 State St., Chicago.

**WANTED**.—A salesman traveling through Southern States selling retail jewelry trade to take a side line. Address B., care of THE JEWELERS' CIRCULAR.

**WANTED, A WINDOW DRESSER**.—Professional preferred; although those having had a little experience, with good ideas, may apply. Permanent position guaranteed to capable party. Address Spartan, care of THE JEWELERS' CIRCULAR.

## To Let

**TO LET**.—A large office, 20 x 40, first floor, No. 11 Maiden Lane. \$60 a month.

**FOR RENT** in Corbin building, 11 John St., sixth floor, half of an office with or without large safe convenient for jeweler. For further particulars, address the janitor of the building.

**BROADWAY STORE** near the Post Office; desirable location; moderate rent; lease. Apply on premises, 2 Astor House.

**TO LET**—Part of office 15 Maiden Lane; steam heat, also burglar alarm. For particulars apply to Martin, Copeland & Co., 15 Maiden Lane, City.

## Miscellaneous.

**I BUY JEWELRY STOCKS**—Manufacturers, jobbers and retailers desiring to dispose of surplus or entire stocks of diamonds, watches and jewelry can find quick cash buyer by addressing Stephen S. Harmon, 134 East 96th St., New York City.

**RICH** cut glass to exchange for rings, diamonds, watches, china and silver ware. Brighton Glass Cutting Co., New Brighton, Pa.

**STOLEN**—A gold watch, 14 karat case. Marked inside E. T. E. B. E. C. No. 634,923. E. Howard & Co. movement, No. 220,614. The watch needed repairs; make note of numbers so as to stop it if offered. A suitable reward for its recovery. Address B, P. O. Box 284, Hartford, Conn.

## DEMAGNETIZING.

**PERFECT WORK**—Watch repairing in all its branches; all work warranted. Winslow & Penney, 608 Masonic Temple, Chicago.

**FOURTEEN** karat gold solder that will flow on eight karat work; makes a hard solder job a pleasure. With this solder there is no danger of melting low karat specs. No white joints on rings. It is just what you want. Sample by mail 25 cents. F. W. Hall, Sterling Silver Novelties, Columbus Memorial Building, Chicago, Ill.

**WANTED TO PURCHASE**.—Good paying jewelry store for cash in New York or Brooklyn. Address L. B., care THE JEWELERS' CIRCULAR.

## For Sale.

**FOR SALE**—A first-class optical store, stock and fixtures, in a city of over 100,000 inhabitants in New York State. Best location in city; for full particulars address A1 Chance, care of THE JEWELERS' CIRCULAR.

**ASSIGNEE'S SALE** of jewelry, stock, watches, silverware, jewelry show cases, safe, tools, engraving machine, etc. Must be sold. Address E. O. Dilley, assignee, Warren, Ohio.

**FOR SALE**.—The leading jewelry business in one of the best railroad towns, of 3,000 inhabitants, in northern Illinois. Only one other store. Address S, care of THE JEWELERS' CIRCULAR.

**FOR SALE**.—Jeweler's safe; 4 ft. 7 in. high, 3 ft. wide. Burglar-proof chest, double combination lock. Price, \$700. Also three counter and upright showcases. J. C. Proudman, 307 Eighth Ave., New York City.

**FOR SALE**.—Rare bargain. Our old plate glass jewelers' showcases and counters. Hyman, Berg & Co., State and Washington Sts., Chicago, Ill.

**FOR SALE**.—An old established jewelry store in a city of over 20,000 inhabitants near Boston. Inventory about \$6,000. Address "Snap," care of THE JEWELERS' CIRCULAR.

**\$450** buys a stock of jewelry and fixtures in a town of 1,000 inhabitants; no other watchmaker within 25 miles of me. Address at once C. K. Keil, Thorpe, Wis.

**FOR SALE**.—Do you want it? Lovely cottage near State Park, Adirondacks. Pure air; pure water; no malaria; no mosquitoes; fine hunting and trout fishing; price \$2,000; cost \$3,000. P. O. Box 26, Wevetown, N. Y.

**\$500** will buy the fixtures and good will of jewelry store; large Marvin safe, electric clock, electric lights and all modern fixtures; repairing will average \$10 weekly; rent only \$22 50 per month. Am the inventor of several patents which require my aid atention. Apply to B. H. Berkman, 56 Vernon Ave., Long Island City.

## FOR SALE—TOWER CLOCK.

Made by the Howard Clock Co.; dial trains, connecting rods and hands for two 3-foot dials; suitable for store front, church public building; in use only nine months; will be sold cheap.

**HENRY ABBOTT,**

No. 2 Maiden Lane, New York.

**\$5,000** for long established retail Jewelry business in city of 100,000 inhabitants;

**YEARLY PROFIT ABOVE EXPENSE, \$3,500.**

Can be greatly increased by additional capital if desired.

Satisfactory reasons for selling given to parties with necessary cash capital. Address,

**CHANCE** care of THE JEWELERS' CIRCULAR.

## SAFES FOR SALE.

(CHOICE OF TWO.)

Will sell at one fifth the original cost; size, 56x38 inside measurement. A1 ply to or address,

**OPPORTUNITY,**

Care THE JEWELERS' CIRCULAR.

## FOR SALE.

The Old Established Jewelry Business of G. A. SCHULTZ (Dec'd), is for sale at a great bargain.

New fixtures throughout; good location. Address

**HELENA SCHULTZ, Ex'trix,**

Corner 7th & Market Streets, LOUISVILLE, KY.

## TO LET! PART OF STORE.

**Chas. Jacques Clock Co.**

22 CORTLANDT STREET, NEW YORK.

## Cheap, Bright Offices To Let

singly or in suites, in the handsome new buildings,

**14 and 45 MAIDEN LANE.**

**Rents \$350 up;** elevator, steam heat, electric lights, etc. **E. A. CRUIKSHANK & CO.,** 176 Broadway.



**The Latest Patents.**

ISSUE OF MARCH 27, 1894.

**517,096. RING-GAGE.** WILLIAM F. DOLL, Winnipeg, Canada. Filed Oct. 4, 1893. Serial No. 487,140. (No model)

In a ring gage, a hollow drum A, shaped as the frustum of a cone and having ring measuring scales marked

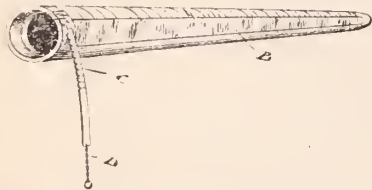

thereon, a portion of its side being cut away, in combination with a graduated tape-like measure secured at its one end to the said drum, the other end passing out through a slot in the drum in proximity to the fast end of the measure.

**517,208. CALIPER-GAGE.** CHARLES E. BILLINGS, Hartford, Conn. Filed Nov. 3, 1893. Serial No. 489,932. (No model.)

**517,265. DIAMOND-SETTING.** FRANK P. D'ARCY, Kalamazoo, Mich.—Filed June 13, 1893. Serial No. 477,448. (No model.)

In a diamond setting having prongs, the combina-



tion of the prongs with enamel placed in grooves on the side of the prongs next the gem and adapted to be pressed firmly against the gem.

**517,275. ORNAMENTING AND ETCHING PRECIOUS METAL.** HANNIBAL GOODWIN, Newark, N. J.—Filed July 22, 1893. Serial No. 481,226. (No specimens.)

In the process of ornamenting plates of precious metal, the process of forming raised or relief surfaces and ornamenting the same, which consists in imposing a design in resisting matter upon a plate, parts of said plate remaining bare, then immersing said plate in a bath containing iodine in any of its forms, and subjecting the same to an electric current and thus etching out the bare parts, and then covering up the said etched out portions with a suitable resisting matter, such as wax, and cleaning off the surfaces in relief, then ornamenting said relief parts by oxidizing or staining them or depositing upon them metal in contrast with that at the etched out parts.

**DESIGN 22,151. BACK FOR BRUSHES, ETC.** CHARLES GRAFF, New York, N. Y.—Filed Dec.



26, 1893. Serial No. 494,817. Term of patent 7 years.

**Expired Patents.**

EXPIRED MARCH 27, 1894; GRANTED MARCH 27, 1877.

**188,757. TOOLS FOR OPENING JEWELS.** A. SCHWERTER, New York, N. Y.—Filed Dec. 12, 1876.

In an instrument for opening jewels, the combination of the screw c, provided with the plain portion c', with

the jaws a and a', the said screw forcing the jaws apart against the action of their spring, the plain portion c'



acting as a steady pin to add to the rigidity of the jaws.

**188,861. COMBINED CLOCK AND MIRROR.** HENRY J. DAVIES, New York, N. Y.—Filed Jan. 17, 1877.

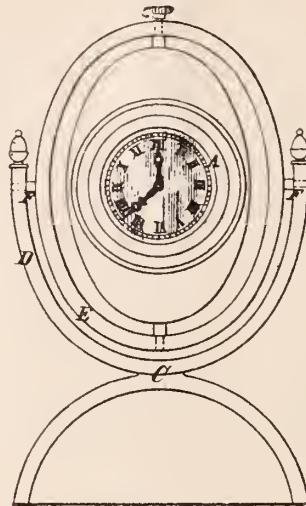

The clock and mirror connected back to back, in combination with a frame or support, in which such clock and mirror are so pivoted as to be reversible.

**188,865. ALARM-CLOCKS.** HENRY J. DAVIES and WALTER D. DAVIES, New York, N. Y. Filed Feb. 14, 1877.

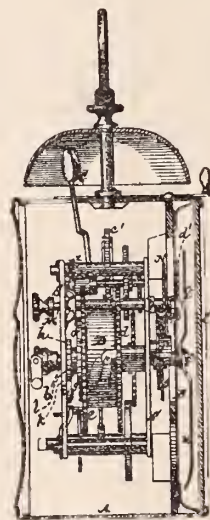

The combination, with the winding-arbor b and main-spring D, of the ratchet-wheels g and h, having a fast and loose relation, relatively, with said arbor, and provided with one or more engaging studs or stops, k and l, the loose main alarm-driving wheel e, and the pawls f i.

**188,901. EYEGLASSES.** HENRY H. HEMPLER, Washington, D. C. Filed Feb. 3, 1877.



The combination of an eyeglass-spring having elongated slots near its ends, with nose-pieces C C having

guide-rods passing through the slots, the whole adapted to give both a longitudinal and pivotal motion.

**188,930. BUFFING AND POLISHING MA-**

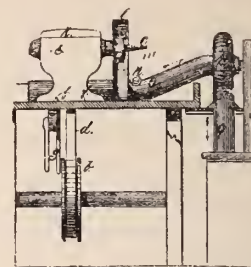

CHINES. J. McWILLIAMS, Providence, R. I. Filed Sept. 3, 1876.

**The Watch Insulator Case Dismissed by the Court.**

NEW HAVEN, Conn., March 28.—Judge William K. Townsend, in the United States District Court to-day, handed down a decision in the case of the Newark Watch Case Material Co., Newark, N. J., against the Wilmot & Hobbs Mfg. Co., of Bridgeport. The action is a bill in equity asking for damages for an alleged infringement of patents belonging to complainant. The patents in question are on a watch protector. It consists of two pieces of highly magnetic metal, fastened together by a spring joint and shaped like a watch. The inside is lined with plush or other non-magnetic metal.

The object of the invention is to protect the works of watches from being magnetized when brought into close proximity with a dynamo or other electrical machinery.

Judge Townsend finds that patents were granted June 31, 1866, to W. W. Corell and to W. O. Sumner in August, 1867, on similar devices. The Corell patent was on a protector similarly constructed, but designed to protect watches from pickpockets. Judge Townsend holds that a patent to stand must have evidence of creative thought. The patented article of 30 years ago to protect against pickpockets serves to protect against the dynamos of to-day. The defense was non-infringement of the patent, that claim merely covering an aggregation of old elements, and that the patent is invalid in view of the state of the art. But, although an infringement is proved, Judge Townsend finds that the plaintiffs had not made an invention, but had carried forward a former invention, in form, proportion and degree. He accordingly orders a decree to be entered dismissing the bill.

Every day sees some new invention or improvement to facilitate the carrying or delivering of custom work; but none of them have been more successful than the new scheme devised by Martin Brunor & Son, electroplaters, which consists in the use of a bicycle provided with a bag. This bag or satchel is especially adapted for carrying jewelry and small pieces of silverware. Mr. Brunor is enabled by this new idea to deliver the work to the customers in the city with promptness and despatch.



**The New Riefler's Clock Escapement and Pendulum.**

**T**HE CIRCULAR has at different times enlarged upon the new clock escapement and pendulum invented by S. Riefler, of Munich; our contributor, Carl Dietzschold, of Karlstein, Austria, recently forwarded the following illustrations and description of the several parts. The gentlemen says:

The inventions of the civil engineer, S. Riefler of Munich, in the domain of clocks of precision are producing great sensation both in Germany and countries abroad. As is known, the objects of the invention are a peculiarly constructed compensation pendulum, the rod of which is two-thirds of its length filled with mercury, and an escapement, which does not act upon the pendulum direct but upon its suspension spring.

The escapement is a clock pin escapement the escape wheel of which is composed of a locking wheel with Graham anchor teeth, and a lifting wheel with the lifting planes at its teeth. Still, we think, many clock manufacturers will combine the two wheels into one, without impairing the quality of the escapement. The operation is that of an escapement with constant force, since by the impulse is imparted by the bending of the suspension spring. But Riefler places the pins at the spot where they co-operate, so that they are flattened in a slightly different manner than shown in fig. 6.

The anchor scapes over  $10\frac{1}{2}$  teeth, therefore a little more than over one-third of the circumference, and is firmly united with the upper part of the suspension spring bezel. To impart motion it revolves around knife-edges. The impulse is communicated to the pendulum, as stated, not by means of an anchor fork, but by the anchor, which in turning stretches the suspension spring, which previously conducts the anchor beyond its locking position.

It is important hereby that the locking pin anchor makes no further motion than exactly the locking and lifting angles, although a complimentary angle is described by the pendulum, which, for astronomical clocks, amounts to from  $1^\circ$  to  $1\frac{1}{4}^\circ$ , and for steeple clocks to  $2\frac{1}{2}^\circ$ . According to the preceding remarks, the escapement is intimately connected with the pendulum suspension. The following is the description: *a*, the escapement. According to fig. 2 *R* is the locking wheel, *H* the lifting wheel. The anchor pins seize into both. By taking off the pins at the place where the locking pin depths, the effect produced is fairly advantageous. Besides this, the locking faces of the pins have an inclination of  $12^\circ$ —contrary to that of the watch lever escapements, so that a very small impulse is exerted by the locking tooth upon the anchor, which is opposed by the power of the suspension spring. But as soon as this ceases, while the pendulum makes its return oscillation, the anchor may almost without power be conducted past this position, after which the lifting faces begin to act at once.

The anchor body is cut open, both at the place where the pallet pins are located and at the tension axis. The former permits a slight rotation of the pins, whereby the drop takes place, the latter adjusts the width of the anchor. The suspension, which accommodates the spring bezel, is a 4-square story frame, upon which the parts for bearing the pivots of the spring bezel rest, and which also contains the two glass-hand steel knife edges. Besides this, the anchor is immediately screwed together with it. The anchor axis concurs with the edge of the steel knife edges.

taken that the oscillating pendulum support cannot become displaced in the direction of the anchor axis, whereby those of the anchor pins, intended to work together with the locking wheel, becomes effective with the lifting faces of the lifting wheel. The screws *b* and *b*<sup>1</sup>, which are screwed back after regulating, as otherwise losses due to friction would occur, serve for this purpose.

The circular, very hard jewel plates *P* are in a bezel; they can be raised and lowered by screws *Z Z*, Figs. 2 and 3, which depth from below through their centers, in conjunction with the small screws *d d d*, whereby

*S. Riefler's Hemmung und Pendel.*

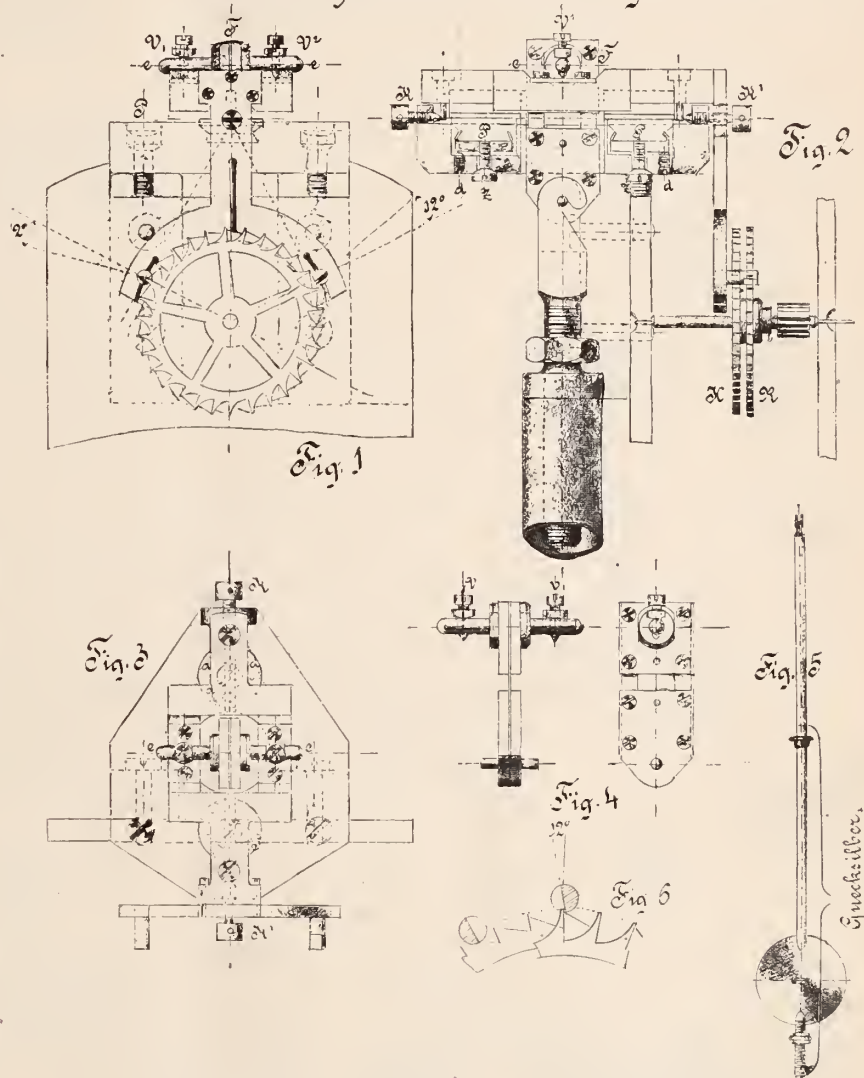

DRAWN FOR THE JEWELERS' CIRCULAR BY CARL DIETZSCHOLD.

If the suspension is lifted off, the suspension support will be seen, which is screwed fast to the back of the frame, and which contains the two stone plates, upon which the knife edges rest. The suspension support is a horizontal plate, which rests upon two strong brackets.

For the performance of the escapement it is necessary that the depth distance of the anchor and scape wheel is truly regulated, that the anchor staff, knife edges and rotation axis of the spring, all three concur together truly, for which a number of regulating devices are introduced. Care is also

the depth distance of anchor, locking and lifting wheel is regulated. To have the plates truly horizontal, and so that the knife edges touch truly, equally at all places, the three screws *d* are located under each.

It finally remains to regulate the rotary axis of the suspension spring truly, against the knife edges, for which purpose serve the screws *v v*<sup>1</sup>, which are screwed from above into the body of the spring bezel *e e*, and which, when screwed in, lift the suspension spring, while in a contrary case they lower it. It will be seen from the above that the arrangement perfectly agrees with that of



the pin anchor; the scape teeth contain the locking faces, and the fork is dispensed with, because the anchor is united direct with the suspension oscillating around knife edges. The impulse is given by the bending of the suspension spring.

THE MERCURY COMPENSATED PENDULUM OF S. RIEFLER.

Is an improvement of the Graham pendulum. Great advantage though Graham's compensated pendulum has, as compared, for instance, to the grid-iron pendulum, it has nevertheless decided disadvantages, for instance, it operates badly when the temperature differs at different heights—say, in a heated room, or when sudden changes of temperature occur. Again, its shape offers fair amount of resistance.

In order to correct these several evils, Riefler sought to construct a pendulum of a lentil shaped body, and the compensating mercury column of which is high enough to reach through several strata of air. For this purpose he placed a heavy brass bob upon the pendulum rod, which is a Mannesmann tube,\* 16 millimeters in width and about one millimeter thick, and for about two-thirds of its length filled with mercury.

\* These tubes are made from the whole steel block, consequently they have no seam.—NOTICE BY TRENIL.

Since the brass bob is fastened in the center, as shown in fig. 5, its changes of size, caused by variations of temperature, have no influence on the compensation. It is otherwise, however, with the Mannesmann tube, each of which is tested in a scientific institute near Berlin; the different tests resulted in showing variations of the co-efficients of expansion of the tubes, amounting to  $1\frac{1}{2}$  per cent.

The calculation for the compensation must therefore be made according to the co-efficients of expansion of the corresponding steel tube of each pendulum. The calculation is in consequence of the great precision in measuring so certain that the probable error of compensation of these pendulums does not exceed 0.005 sec. per day and  $\pm 1^\circ$  C. variation of temperature. A subsequent correction of the compensation is therefore unnecessary; it is well-known that all other compensated pendulums require this.

The calculation starts from the steel tube and mercury column, and the weights of the bob adapted therefore is ascertained subsequently. The measurements obtained by calculation have proved to be theoretically correct.

The rate of the pendulum is regulated in three different ways:

1. By screwing the bob up or down.  
2. By screwing the correction discs up or down.

3. By adding regulating weights, laid upon a bracket to be fastened in the center of the pendulum rod. Upon each disc is stamped the acceleration it imparts to the pendulum in 24 hours. When the acceleration amounts to 1 sec. per day, these discs are of German silver; when less—say from 0.5 to 0.1 sec., of aluminum. Until now the pendulum was made either as seconds or  $\frac{3}{4}$  seconds pendulum. The weight of the former amounts to 6 kilogram.

It is next of the highest interest to ascertain how the construction based upon purely physico-mathematical reasonings has proved to behave in practice.

The daily rate from Sept. 1, 1891, to Dec.

12, 1892, was  $-0.07$  sec. and  $+0.09$  sec., a mean of 0.30 sec. per day; again, from Dec. 5, 1891, until Jan. 10, 1892, between 0.08 and 0.11, a mean of 0.023 sec. per day at a temperature of  $-57^\circ$  C. to  $+5.6^\circ$  C., and finally, from Aug. 16th until Sept. 5, 1892, between  $-0.05$  and  $+0.06$  sec., a daily mean of 0.010 sec., at a temperature of  $+20.6^\circ$  C. to  $25.3^\circ$  C. The clock stood in a room subject to very sudden changes of temperature.

From this resulted a daily compensation error for  $\pm 1^\circ$  C. of only 0.008 sec. The mean for one year was 0.00085 sec. The compensation was not corrected, and the pendulum remained unaltered. A comparison between the compensation constants with the other astronomical clocks resulted in showing that Riefler's pendulum and escapement furnishes a better result than all hitherto known devices, as the next one shows already 0.0025 sec.

The dissertation prepared by Dr. Anding, Munich, contained in Vol. 133 of the astronomical reports, on Riefler's Clock No. 1, shows above mean of the compensation constants, and for the barometer constants 0.010 sec. According to more recent reports, the rate of the regulator No. 1 has still essentially improved.

For steeple clocks also, both the escapement and pendulum of Riefler were used, and gave most excellent results. The escapement and pendulum were exhibited at the World's Fair, Chicago.

### Canada and the Provinces.

W. R. Roberts, Nanaimo, B. C., contemplates selling out.

Samuel Breadner, Parry Sound, Ont., is selling out his stock at auction.

Asseltine's jewelry store, in Calgary, Man., was damaged by fire last week with a loss of \$2,000.

The Dueber Watch Case Mfg. Co. have obtained judgment against E. N. Williams, Toronto, for \$6,000. Williams was unable to go to court on account of a recent accident and judgment went through his non-appearance.

Perçy Webster, jeweler, Kentville, N. S., is in Halifax undergoing treatment at the hands of Dr. Kirkpatrick, specialist. On Wednesday Mr. Webster had his eyes seriously injured by an accident which occurred while he was experimenting with some chemicals. The doctor has hopes of saving Mr. Webster's vision.

Stern Bros. & Co.'s diamond cutting works, although the largest in the country have already proved too small to accommodate the workmen which the firm find it necessary to employ in order to keep pace with the work. The loft above the present commodious one at 29 and 31 Gold St., New York, has accordingly been secured, and is already being fitted for the additional cutters and polishers. The excellence of the work done by Stern Bros. & Co. is without doubt one of the reasons which has led to the extension of the plant.

**We Know** THAT WE CAN GIVE YOU BETTER RETURNS ON YOUR OLD GOLD AND SILVER OR WASTE THAN ANY ONE ELSE. TO PROVE THIS STATEMENT GIVE US ONE TRIAL.



**GEO. F. BAKER,**  
GOLD AND SILVER REFINER  
AND SWEEP SMELTER. **PROVIDENCE, R. I.**

**OPPENHEIMER BROS. & VEITH,**  
WATCHES AND



**DUEBER CASES, HAMPDEN MOVEMENTS.**  
AMSTERDAM, HOLLAND, 2 TULPSTRAAT. LONDON, ENG., 28 HOLBORN VIADUCT.  
NEW YORK, 35 MAIDEN LANE.





TRADE MARK.

# L. STRAUS & SONS,

IMPORTERS AND MANUFACTURERS,



TRADE MARK

China, Pottery and Glassware, 42, 44, 46 & 48 Warren St. and 116 Chambers St., N. Y.  
PARIS, CARLSBAD, RUDOLSTADT, LIMOGES, STEINSCHONAU.

**WOOD & HUGHES,**  
STERLING SILVERWARE MANUFACTURERS  
New York Agents for the Derby Silver Co.'s  
FINE QUADRUPLE PLATED WARE,  
No. 16 JOHN STREET, NEW YORK.  
206 Kearney St., San Francisco, Cal.  
HASKELL & MUEGGE, Agents.



## IRONS & RUSSELL,

(SUCCESSORS TO CHARLES F. IRONS.)

MANUFACTURERS OF

SOLID GOLD **EMBLEMS** ROLL PLATE  
PINS, CHARMS AND SOLID GOLD RINGS.

102 Friendship Street, - - Providence, R. I.



# The "Bryant" Rings.

Are widely advertised and will sell  
when anything will, therefore  
every Retail Jeweler should buy them.

IF NOT CALLED UPON BY OUR TRAVELERS  
ORDER DIRECT FROM

**M. B. BRYANT & CO.,** - 10 MAIDEN LANE, N. Y.

OLDEST RING MAKERS IN AMERICA.



ESTABLISHED 1870.

## J. L. CLARK,

SWEEP SMELTER AND REFINER OF GOLD AND SILVER.

Buys every kind of Gold and Silverware, Jewelry, Watches and Platinum. Full market value paid.

No. 724 Filbert Street, Philadelphia, Pa.

SEND BY EXPRESS or Registered Mail. If my price is not satisfactory, I will return all articles

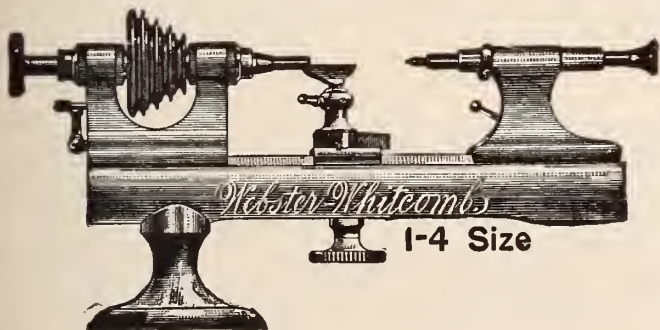

STRONGEST GUARANTEES.

Quality  
Maintained.

Prices to  
Suit the Times.

Ask for our New  
Prices and  
Terms for 1894.

## American Watch Tool Company,

Chymistry Dist., Waltham, Mass., Stoney Batter Works.

We Have Removed to  
**57 MAIDEN LANE.**  
LEONHARDT & CURRAN,  
MANUFACTURERS OF DIAMOND MOUNTINGS.

## VICTOR. ⊗ ⊗

SIMPLEST FEED. ALWAYS THE SAME.  
GUARANTEED FOR ONE YEAR.

## THE VICTOR FOUNTAIN PEN

(Pat. Feb. 4, 1890.)

THE BOSTON PEN CO.,

N. C. Whitaker & Co., Proprietors.

363 Washington Street, Boston, Mass.,

Manufacturers of finest quality

TORTOISE : SHELL : AND : HORN : GOODS  
in every variety. Also Aluminum Hair Pins.

Send for Illustrated Pen Price List No. 1.

LOOKING FOR THE

## COLUMBIAS?

AN ADJUSTABLE EYE-CLASS THAT  
CAN'T BREAK NOR GET OUT  
OF ORDER.

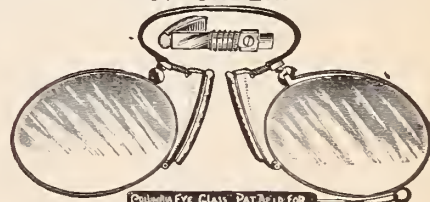

DON'T BUY UNTIL YOU SEE ONE OF OUR  
COLUMBIAS.

## E. KIRSTEIN'S SONS CO.,

SOLE MANUFACTURERS,

ROCHESTER, NEW YORK.

Send us your Rx. work. when you want same at once.



# FERDINAND BING & Co.,

106 GRAND ST., N. Y.

—NEW DESIGNS IN—

China Clocks and Gilt Bronze Sets, Fine Painted Dresden Goods in  
Vases, Cups and Saucers, and Plates; Cararra Marble Statuary,  
French Cabinets and other Fancy Furniture.

## Rich Cut Glass

AND

DECORATED ART WARES.

Mt. Washington Glass Co.,

New Bedford, Mass.

RICH DISPLAY OF GOODS AT

New York Store: 46 Murray St.

When you visit Chicago do not fail to inspect our full line of goods at the new store of Pairpoint Mfg. Co., 224 Wabash Avenue.

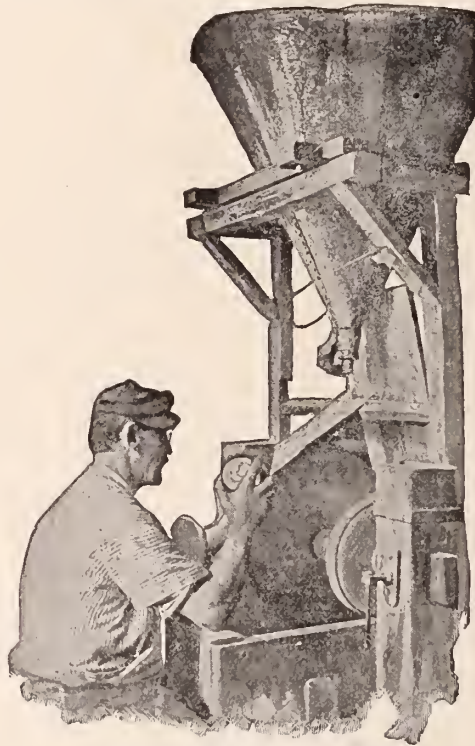

GLASS CUTTER AT WORK.



61 Hanover Street, Boston, Mass.

Sales made for Jewelers only in their established places of business. Can give best references of any auctioneers in America.

*All communications strictly confidential.*

# CHARLES AHRENFELDT & SON

50, 52 & 54 Murray Street, New York.

.... IMPORTERS OF ....

# China, Glass AND Bric-a-Brac,

ESPECIALLY ADAPTED TO THE JEWELRY TRADE.





## The Rambler's Notes.

WHAT THE RAMBLER SAW AND HEARD AMONG THE DEALERS IN ART POTTERY, CUT GLASS, BRONZES ETC.

EXQUISITE A. D. CUPS AND SAUCERS.

A MOST artistic and fascinating conception in after-dinner coffee cups is shown in the Limoges specialties of P. H. Leonard, 76 Reade St., New York. These are in the form and color of a full blown red or yellow rose, with a butterfly perched upon the edge, forming a perfect handle. The saucers are in the shape of rose leaves, and fully carry out the idea expressed in the cups. This is but one of many designs which are shown among the cups and saucers in the new goods just opened by this firm. Many beautiful decorations and shapes have also been introduced. One decoration, of an entirely new type, shows colored or gold feathers painted in an artistic arrangement; another consists of a heavy dark olive green shaded body, with full decorations; in some this green is combined with a shrimp pink. The latter decoration is shown in a full line of chocolate, ice cream, boudoir, desk, lettuce, tête-à-tête and toilet sets, trays, bon-bon boxes, salad bowls, cups and saucers and cabinet and table novelties. Among the latest specialties introduced are celery dips, picture frames and salts.

FERD. BING & CO'S FINE LINE OF BRONZES.

A SPECIALTY is now being made of bronzes by Ferd. Bing & Co., 106 Grand St., New York, and they have devoted a room on the third floor of their building exclusively to this line. The magnificent assortment of new figures, groups and busts, which have lately been added, show a number of striking and beautiful finishes. Pairs in particular, are shown more extensively than hitherto, in both the large and small pieces. Among these may be mentioned two large busts by Marcey, Bayadere and Gitana, a beautiful pair of figures, male and female, in green finish, called respectively, *Génie des Airs* and *Reine des Eaux*, and the busts, Trouville and Dieppe, which are shown in many finishes. Among the most

artistic figures are *Libellule* by Rigau, *Diana* resting in the air and a small piece by Baveau, *Gloria*, of which the original subject is from the Salon, 1892. Small bronze cupids and figures on marble slabs form an attractive line of paper weights. In Viennese bronzes is an assortment of beautifully executed Oriental figures and groups in natural colors. Arabs, Moors, Turks and other children of the East are shown on camels or on foot, either sleeping, praying, kneeling, smoking, begging, vending, hunting or fighting, and in their expression, posture and dress are portrayed with a detail which is marvelous in its accuracy.

\*

THE NEW ROYAL CUTTING.

L. STRAUS & SONS, 42 to 48 Warren St., New York, have just received and are now showing a full line of cut glass in their new Royal cutting described in this column three weeks ago. While of a moderate price, this cutting is both heavy and rich and will compare favorably with some of their finest patterns. Bowls in this pattern particularly are shown in a large variety of shapes and sizes; many are very attractive.

\*

A NEW PIECE IN CUT GLASS.

AMONG the latest pieces in cut glass shown in the warerooms of T. B. Clark & Co., 53 Park Place, New York, is a footed ice bowl in the Jewel cutting. The piece is six inches high, and unlike former ice tubs, is vase shaped, and has curved handles. In general outline it is more beautiful than almost any of its predecessors.

THE RAMBLER.

## Indian Pottery.

A WRITER in the *Indian Magazine and Review*, dealing with Indian pottery, says:—Of all materials put in use by the ancient inhabitants of India, clay must, at a very remote period, have held a large place. The plains of India are bountifully supplied with clay, by the inundations of the great rivers, the Indu and more particularly the Ganges, and the native potter found ready to his hand an unailing supply

of the material for his art. The discovery of the plastic nature of clay, and the facility with which it can be worked into any shape, is not above the capacity of the rude savage. There is abundant evidence that sun-dried bricks preceded the art of working vases; desiccated objects, however, have an ugly tendency of resolving themselves into their original mud; so that even in the most favored countries, as Egypt for example, the state of the atmosphere will not allow crude clay to survive a single winter. The baking of it so as to produce an indestructible tenacity was an immense advance, and probably the result of accident rather than design.

THE PLASTIC ART.

The Hindus, unlike the Egyptians, Assyrians, and even the Romans, do not seem to have used bricks to impress upon them the names of their kings, or their governors, or the buildings for which they were intended, or as tablets for their public archives, their astronomical computations, their annals, their title deeds, and their religious dedications. This is much to be deplored, for had they done so we should not be left to grope in the dark with regard to the history of their early civilization; but we should have detailed accounts of particular buildings, and the chief events connected with the various buildings of the vast peninsula. The modelling in clay the forms of the physical world gave rise to the plastic art; and Hindu pantheism, better than any other religious creed, served to diffuse it throughout the Indian provinces.

The invention of the potter's wheel was an immense improvement upon the rude methods previously adopted in fashioning vessels by the hand alone. By the application of a circular table, laid horizontally, and revolving upon a central pivot, on which the clay was put, all combinations of forms could be produced as the wheel spun round, and vases became symmetrical in their proportions and true in their capacity. As with every invention respecting which nothing is known, that of the wheel has been ascribed to all the nations of antiquity. It is represented in full activity in Egypt as far back as 1400 B. C.; we find mention of it in the Scriptures (2 Samuel xvii. 28; Jeremiah



## The Connoisseur.

(Continued from page 39.)

xviii. 1—9); while vases with marks of the wheel upon them have been unearthed in Assyria; and we may safely conclude that fictile vessels for domestic or religious uses were made at an early period in India. There is evidence of a brisk intercourse and continual exchange of commodities having begun in remote times between the Hindus and the countries on the march of their frontiers. How eagerly sought was the exchange of manufactured articles on the one hand, and of raw products on the other, between the kings of Babylonia and Egypt, the letters lately discovered at Tell el Amarna sufficiently show. Shall we be deemed rash if we assume that the Hindus could not and were not behind other nationalities in this respect?

### ORIGIN OF ENAMEL.

On the other hand, the ancient Semites, like their kinsmen of Palestine, set no great store by the potter's art. They deemed the material too common; their love of the precious metals making them prefer gold and silver and the scarcely less costly bronze for display or necessity. In India, whether owing to difference of race, with its large admixture of Turanian blood, than which none is more imitative or artistically endowed, or religious scruples which will not allow natives to use the same vessel or idol

twice lest it should be defiled, the fact remains that no country in the world has so great a demand for earthen pots and pans of a common kind, but ever of pleasing shapes, and must have had for countless generations. So universal is the manufacture of earthenware at the present day that scarcely a hamlet is found without a kiln.

The desire of making terra-cotta less porous and better fitted for retaining liquids led to the invention of an impervious covering or glaze, consisting of opaque glasses or enamels, which in Egypt are as old as the 18th dynasty. The employment of copper with a little lead to produce a brilliant blue enamel was very early, both in Babylonia and Assyria; the use of tin for a white enamel, found on the encaustic tiles of Babylonia, Assyria and Egypt, anticipated the rediscovery of it by Luca della Robbia in the fifteenth century.

### FANCY EARTHENWARE.

To-day native artists prepare enamels to be applied to terra-cotta precisely as did the Egyptians, Chaldeans, and Persians, or, indeed, modern Europeans. In every instance the coloring materials were and are produced by oxides, which lend themselves to a number of combinations with glass. Greens, blues, greys and yellows may be obtained pure, or combined when graduated tints are required. A sub-oxide of copper and iron oxide will both produce red. Save in the matter of decoration, which is more reticent, Indian fictiles bear great similarity

to the Persian. There is evidence that the art of terra-cotta or unglazed earthenware was practised in India before the time of Manu, and the specimens of it which appear on ancient Buddhist and Hindu sculptures, resemble in every respect the countless pieces that are thrown on the rustic wheel, or sold in the bazaars of Bengal.

Among the fancy earthenware expressly made for exportation, betraying a certain effort to render them artistic, and therefore effective, should be mentioned that made at Travancore and Hyderabad; the red ware of Dinapur, the black and silver pottery of Azinghar and Surrujurrh, the *bidr* imitation of Patna and Surat; nor should the gilded pottery of Amroba and Rajputana, the blue fictile pieces of Sindh and the Punjab, or the pottery of Madura, remain unnoticed. They are all enamelled except the last, which is partly pierced and unglazed. The earthenware that comes from Kota is painted. Of the Azinghar majolica it is impossible to speak in eulogistic terms. Like the greater proportion of the art products of Benares, and eastward of it, the shapes are ill conceived and feeble, they do not stand well, the fine black color and good potting of this majolica serve but to accentuate affected and meaningless ornament. The writer also deals in an interesting manner with various other branches of the subject.

They never pardon who commit the wrong.—*Dryden*.

# THE JEWELERS' CIRCULAR

IS FIRST IN THE FIELD IN EVERY SENSE.

SEND US \$2.50 AND GET "THE CIRCULAR" FOR ONE YEAR AND A COPY OF

## "WORKSHOP NOTES

For Jewelers and Watchmakers."

BEING A COLLECTION OF THE LATEST PRACTICAL RECEIPTS ON THE MANUFACTURE AND REPAIRING OF WATCHES AND CLOCKS, AND ON THE VARIOUS PROCESSES ENTERING INTO THE MANUFACTURE AND REPAIRING OF JEWELRY, AS COLORING, POLISHING, ENAMELING, ANNEALING, OXIDIZING, ETC. IN SHORT A THOROUGH COMPENDIUM OF THE NUMEROUS MECHANICAL DEPARTMENTS OF THE JEWELERS' AND WATCHMAKERS' SHOP.

200 PAGES, BOUND IN CLOTH, STIFF COVERS.

THE JEWELERS' CIRCULAR PUBLISHING CO.,  
189 BROADWAY, NEW YORK,



# HINRICHS & CO.,

29 AND 31 PARK PLACE,  
NEW YORK.

## BRIC-A-BRAC AND ART POTTERY.

### SEEING



is believing, and to see the product of our Optical prescription department, will lead you to believe that your popularity as an Optician will increase if we fill your orders.

**QUEEN & CO.,**

MANUFACTURING OPTICIANS,

1010 Chestnut Street, Philadelphia.

**McINTIRE, ULMER & CO.,**

Manufacturing Opticians,

FRAMES, LENSES,

PREScription WORK,

Expert Work at LOWEST PRICES.

WHOLESALE ONLY.

S. E. Cor. 8th & Sansom Sts., PHILADELPHIA, PA.

Special drive in Eye Glass Hooks, \$3.25 per gross in lots not less than one-half gross. Single doz. 35 cts.

PATENT PANELED METAL

## CEILINGS

Stamped Raised Panels.

ARTISTIC AND PERMANENT.

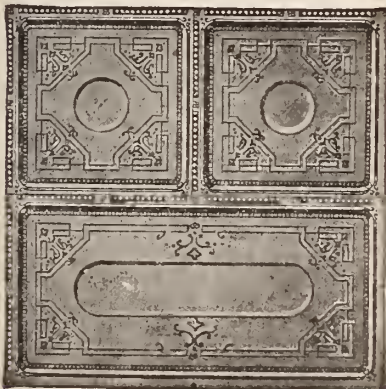

Easily applied in new buildings, and over old broken plaster or wood Ceilings. If interested in building or repairing, send stamp for Illustrated Catalogue, and state if CHURCH, HALL STORE, OFFICE, or SCHOOL Ceiling is wanted. Address

**A. NORTHROP & CO.,** Pittsburg, Pa.

### Headquarters

FOR ELECTRIC & PORTABLE Watchman's Clocks

Lowest Prices.  
Latest Improvements,  
Patents 1886-1893.  
Send for Circular.  
**E. O. HAUSBURG,**  
41 Maiden Lane, New York. THE "ALERT."

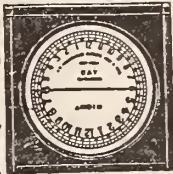

Price, Complete \$10.00

### THE PHILADELPHIA COLLEGE OF HOROLOGY

A Practical School for Watch-Makers.

Most complete school of horology in America, elaborate outfit of appliances. Skilled and competent instructors. Jewelry work and stone-setting taught, also engraving. Send for prospectus.

**F. W. SCHULER & CO.,**  
No. 623 HEED BUILDING, PHILADELPHIA, PA.

### G.A. WEBSTER

42 & 44 Madison St., Chicago, Ill.

**Manufacturer,**

AND WESTERN AGENT FOR

E. G. WEBSTER & SON, of Brooklyn, N. Y.

A. F. TOWLE & SON CO., of Greenfield, Mass

### HENRY ABBOTT,

MANUFACTURER OF

Stem-Winding Attachments

FOR WATCHES,

No. 2 Maiden Lane,

NEW YORK.

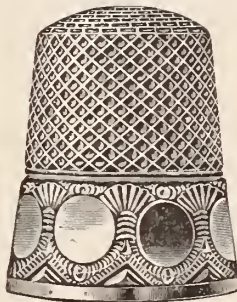

### KETCHAM & McDOUGAL

MANUFACTURERS

GOLD & SILVER THIMBLES,

GOLD COLLAR BUTTONS,

AUTOMATIC EYE-GLASS HOLDERS

198 BROADWAY N Y

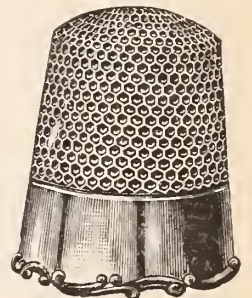

### "Old English"

Coffee Spoon.

\*\*\*



DESIGN PATENTED.

**Towle Mfg. Co.,**

MANUFACTURERS OF

**STERLING SILVERWARE.**

NEWBURYPORT: No. 214 Merrimack St. CHICAGO: Nos. 149 & 151 State St.

**J. R. WOOD & SONS,**  
14 JOHN STREET, NEW YORK.



MANUFACTURER OF



**PLAIN SOLID GOLD RINGS.**  
**SEAMLESS PLAIN SOLID GOLD RINGS.**  
**ENGRAVED AND CHILD'S RINGS.**

No Ring Stamped Different from Quality.  
Send for Catalogue and Price List.

Old Gold and Silver received and estimated on; if amount allowed does not give satisfaction, notify at once and will return at our expense, in same condition as received.

If Your Sales  
Are Not Satisfactory

ADDRESS

**DE B. O. SCOTT,**

20 Murray Street, New York.

AUCTIONEER.

Specialties: Watches, Clocks, Bric-a-brac, &c.

Write for particulars and references.



**The Other Side of Life.**

"If speech be silver, as they say;  
Then by these self-same lights,  
The women, bless their gentle hearts,  
Must all be silverites."  
—Philadelphia Times.

Like the life of a watch is the life of man,  
As it runs its appointed race;  
When his works are ended and all run down,  
Then the coroner takes his case.  
—Indianapolis Journal.

**BETTER THAN SOLOMON'S TEMPLE.**

An exchange reports this dialogue between an old colored woman and Uncle Moses, in one of the streets of Houston, Texas:  
"Where am your darter Ma'ildy hired now?" asked the woman.  
"She am worki' for de mos' 'spectable folks in Houston. Dey am well fixed, shore."  
"H'm! Got silberware and sich, has dey?"  
"I should say so. Dey has silber tin pans, an' de copper am pure gold." — Texas Siftings.

**SETTLED THE DIFFICULTY.**

He had given her the engagement ring, and was telling her fairy stories about the

trouble he had experienced in securing a pure white, flawless stone, when he saw a sad look creep into the eyes but now fired with joyous mirth and gladness.

"What is it, my own?" he whispered in her left auricular appendage.  
"Oh, Harold, suppose—"  
"Yes, sweetheart."



JEWELERS TERM - K GOLD FILLED CASE. —Life.

"Suppose we should get married!"  
"We will, my dearest," he hissed, with a ten-dollar-a-week nerve.  
"And I should lose this ring in the fluff of our velvet carpets?"  
For a moment he was dazed. Then a decorative possibility rushed athwart his prophetic soul, and he said firmly:

"We will have hard wood floors." — Texas Siftings.

**UNCERTAINTY.**

In deep thought he wandered along the shore of the lonely islet.  
The sun had set.  
Anon his gaze wandered over the dimpling ocean, deep in whose bosom reposed the ship and all her crew, save him.  
His lips were moving.  
"Yes," he muttered, "it is still the question of the hour."  
Retracing his footsteps to his rude hut he looks again at the clock, upon whose face only the minute hand remained. —Detroit Tribune.

**THE LATEST ATTACHMENT.**

HE—Yes, madam, this clock will tell you the time of day, the moon changes, the date and—  
SHE—Well, will it tell me when my bonnet's on straight? —Exchange.

Miss Flutter—Did you ask papa?  
Mr. Hopeless—Yes; I asked him by telephone, and I guess you may as well give back the ring.  
Miss Flutter—Oh, dear! What did he say?  
Mr. Hopeless—He said, ring off.

**THOMAS W. LIND, Manufacturer of Jewelers' Findings, 67 FRIENDSHIP STREET, PROVIDENCE, R. I.**



FULL SIZE NEW ROCOCO.



Settings Made in Any Desired Thickness of Stock.

Call or send for samples of my New ROCOCO PATTERNS, for Picture Frames, Cane Heads, Whips, Boxes, Napkin Rings, etc.

Large Assortment of TRIMMINGS for Millinery Ornaments, Scarf Pins, etc

**IF YOU WANT A POSITION  
IF YOU NEED A SALESMAN  
IF YOU NEED A WORKMAN  
IF YOU DESIRE TO EXCHANGE  
IF YOU WANT A PARTNER  
IF YOU WISH TO SELL OUT  
IF YOU HAVE TOOLS TO SELL  
IF YOU HAVE A PLACE TO LET  
IF YOU WANT ANYTHING**

USE THE  
**SPECIAL NOTICE PAGE  
OF THE  
JEWELERS' CIRCULAR,**  
Published Every Wednesday.

Send for Samples.

**Belts  
AND Buckles.**

Elegant designs, Prices as low as the lowest Hair Pins, Link Buttons, Ladies' Combination Shirt Waist Sets and all the latest in **STERLING SILVER NOVELTIES.**

MANUFACTURED BY  
**CODDING BROS. & HEILBORN.**  
North Attleboro, Mass.  
Chicago office, Buck & Hall, 103 State St., Rm. 802  
New York office, C. A. Vanderbilt, 178 B way



ALL KINDS

FANCY WOOD

CHESTS

FOR

TEA SETS

AND

FLAT WARE.



FANCY KID,

CHAMOIS,

SILKS and

BROCADE

CASES,

FOR

SILVER WARE

AND

JEWELRY.

# HEBBARD & BROTHER,

**860 BROADWAY,**

**NEW YORK.**



## THE QUESTION ?

WILL IT TARNISH ? Need

not be asked if your Tissue Paper bears this label.

MANUFACTURED BY

## C. H. Dexter & Sons,

WINDSOR LOCKS, CONN.

◁ BE SURE YOU GET THIS BRAND. ▷

It has been adopted and is now used by the leading manufacturers of this country.

### Jules Jürgensen

OF COPENHAGEN.

The reputation these watches have maintained for Fifty Years has never been equalled, being made on strictly scientific principles and no expense spared to give the Best results in mechanism and timekeeping qualities.

SOLE AGENTS,

John C. Hyde's Sons,  
NO. 22 MAIDEN LANE.



### MARINE CHRONOMETERS,

MANUFACTURED BY

John Bliss & Co., 129 Front St., New York.

We have on hand a number of Chronometers, by various good makers, not new, which have been in service for purposes of navigation, and are excellent instruments. They have been put in perfect repair and will give satisfactory results as to performance. We will sell these Chronometers at low prices, either for cash, or on accommodating terms to suit special cases, or will hire them at moderate rates and allow the hire to apply on purchase.

SEND FOR CIRCULAR GIVING PRICES AND TERMS.





# Opals

**M. D. ROTHSCHILD,**

NEW YORK: 41 & 43 MAIDEN LANE

LONDON: 15 HOLBORN VIADUCT

PARIS: 58 RUE LAFFITTE.

## S. F. MYERS & CO.,

WHOLESALE JEWELERS,

MYERS BUILDINGS, - - NEW YORK.

1894 ISSUE, No. 38,

### OUR ROYAL CATALOGUE

Illustrates all that is new, unique and desirable in everything that pertains to jewelry.

Sent free to dealers who have not received it.

TWENTY-TWO DEPARTMENTS.

SEVEN DOUBLE FLOORS.

Myers Buildings, 48-50 Maiden Lane, New York, 33-35 Liberty St.,

## S. P. HOWARD,

Gold and Silver Assayer.

**Refiner and Sweep Smelter,**

33 MAIDEN LANE, NEW YORK.

Smelting and Refining Works,

28 & 30 Cumberland Street, Brooklyn, N. Y.

Specialties: Sweepings, Gold, Silver and Platinum.

**HENRY FERA,**  
IMPORTER OF DIAMONDS  
AND DIAMOND BORTZ.  
Diamond Cutting and Polishing Establishment.  
10 Maiden Lane, NEW YORK.

For **BADGES AND MEDALS,**

Flag Pins, Class Pins, Class Rings  
and Special Work of all Descriptions.

SEND TO **E. R. STOCKWELL,** MANUF'R.  
19 John Street, New York.

# Emeralds

**E. KIPLING,**

182 Broadway, New York.

ELEVATOR ENTRANCE, 2 JOHN ST.

FRENCH ENGLISH  
CLOCKS AND HALL CLOCKS AND  
MATERIALS. MATERIALS

**CHAS. JACQUES CLOCK CO.,** 22 CORTLANDT ST., N. Y.

## L. LELONG & BRO.,

GOLD AND SILVER

**Refiners, Assayers AND Sweep Smelters,**

◁ SOUTHWEST CORNER HALSEY AND MARSHALL STREETS, ▷

**NEWARK, N. J.**

**SWEEPINGS A SPECIALTY.**

## J. SCHAWEL & CO., 29 John St., N. Y.

GOLD & SILVER REFINERS, ASSAYERS & SWEEP SMELTERS.

STERLING SILVER, 925/1000 FINE IN SHEET AND WIRE.

Soft Platinum, Sheet and Wire for Manufacturing Jewelers.

## WM. BIRMINGHAM & CO.,

MANUFACTURERS OF

All Kinds of Leather Spectacle and Eye Glass

**CASES,**

728 Arch Street, PHILADELPHIA, PA.

## J. PRINCE,

Jewelry Auctioneer,

At liberty from January 1st, 1894. Retail  
Jewelers only. Address,

Rooms 9 & 10, 137 BROADWAY  
N. Y. CITY.

**A.W.C.CO**

# AMERICAN WATCH CASE CO.,

MANUFACTURERS OF GOLD CASES.

11 JOHN ST., NEW YORK.

FOR THE RETAIL TRADE.

# ALBERT LORSCH & Co.,

37 MAIDEN LANE, NEW YORK.

Branch, 167 Weybosset Street, Providence, R. I.

— IMPORTERS OF DIAMONDS, —

Rose Diamonds, Rubies, Sapphires, Emeralds, Opals, Moonstones,

Fancy and Imitation Stones, Novelties.

..... SOLE OWNERS AND IMPORTERS OF

*The Sumatra Gem.*

REG'D. UNEQUALLED IN  
BRILLIANCY AND  
HARDNESS

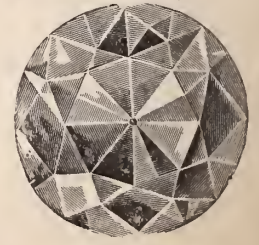
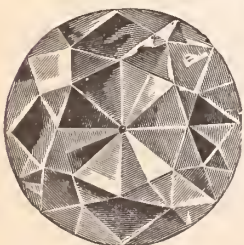

HIGHEST AWARD AT THE COLUMBIAN EXPOSITION, CHICAGO, 1893.

IT PAYS TO KEEP IN TOUCH WITH TRADE AFFAIRS. For 4c a Week will do it. **Subscribe**

1869-1894=Twenty-five Years Oldest, Best Brightest, Newest, =The Jewelers' Circular.



# THE JEWELERS' CIRCULAR

AND HOROLOGICAL REVIEW.

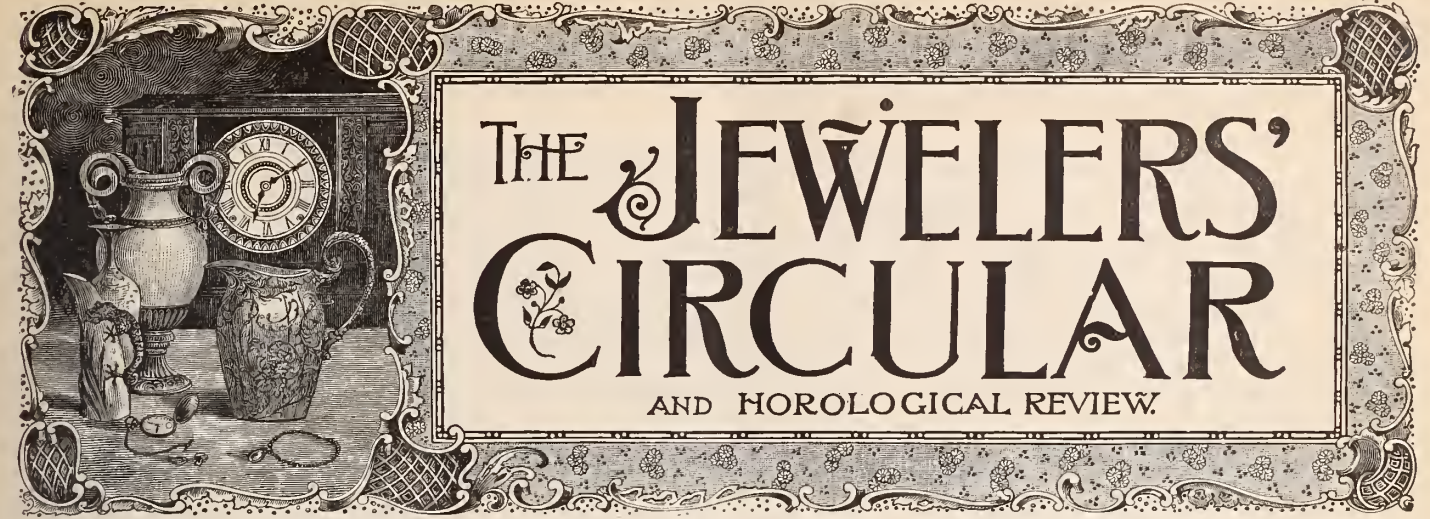

Copyright by THE JEWELERS' CIRCULAR PUB. CO.

189 Broadway, New York.

Entered at the Post Office in N. Y. as second-class matter.

VOL. XXVIII.

NEW YORK, WEDNESDAY, APRIL 11, 1894.

No. 10.

## A POETIC CONCEPTION IN SILVER.

THE recent American victory in international yacht racing by the *Vigilant* over the *Valkyrie* is once more forcibly recalled by the completion of the notable work in silver illustrated on this page. The trophy is a gift to the owners of the *Vigilant* by the New York Yacht Club, who, following the custom consequent to former victories, have presented a work in silver to commemorate the yacht's victory in her defense of the America's Cup. By the deed of gift of the famous international prize, the America's Cup unless won by a challenger, can never pass out of the possession of the New York Yacht Club; therefore as a reward to the several cup defenders, *Mischief*, *Puritan*, *Mayflower*, *Volunteer* and *Vigilant*, the club has presented to their owners magnificent silver trophies, worthy souvenirs of the memorable victories.

The contest to secure the contract to manufacture this latest trophy was a keen one, the successful firm being the Whiting Mfg. Co., New York, who had successfully produced the four preceding cups. That the selection of this company was wise and judicious is potently proved by the completed prize, which has been appropriately termed a poem in silver. In design it is a radical departure from all predecessors in its line, and while it graphically tells the story of the great yachting contest

it still retains distinctly all the features of a pure and graceful vase. It is considered

of the chief merits of the design lies in the perfect manner in which it carries out the idea of symbolizing the contest, giving equal prominence to both participants. This is achieved by the two figures, which are totally different in character.

*Valkyrie* is upon one side, ready to make the attack and to annihilate the enemy. With poised spear she is about to strike. Her open mouth and eyes show the excitement she is under. She is wearing a winged helmet, while around the upper part of her body is a coat of mail, through which is seen the well developed woman. The divided skirt, exposing the right leg and the typical footgear, are all treated with great fidelity. The attacking *Valkyrie* could not possibly show more action. There is nothing lacking in the whole figure, it being marvelously strong in every detail.

The defending *Vigilant* was an original type of an American craft. To represent her there was selected a typical squaw. She is the figure on the left, and is young, handsome, alert, courageous. Clothed in male attire, she is ready to repel the attack of *Valkyrie*. She will fight. There is confidence in her expression and attitude. Only the outlines of the breast and calf show the woman warrior. The buckskin attire, the toma-



THE VIGILANT CUP. DESIGNED AND MADE BY THE WHITING MFG. CO.

hawk ready to use and headdress of feathers are all lifelike. Nothing could be more

one of the most important pieces of its kind that this company have produced. One



# DEITSCH BROS.,

7 EAST 17TH ST., NEW YORK.

## LEATHER GOODS.

EBONY AND SILVER COMBINATIONS.

ORIGINATORS AND MAKERS OF

NOVELTIES IN LEATHER AND STERLING SILVER COMBINATIONS.



\*\*\*\*\*

**CROSS & BEGUELIN,**  
 17 MAIDEN LANE, NEW YORK,

ALL GRADES OF  
 SWISS AND AMERICAN WATCHES, DIAMONDS,  
 GOLD AND ROLLED PLATE JEWELRY, OPERA  
 AND FIELD GLASSES, TOOLS AND MATERIAL.

SOLE AGENTS FOR THE **Rockford Watch Co.** MATERIAL.  
 MANUFACTURERS OF THE **Centennial Watches.**

SEND FOR OUR WATCH MATERIAL AND TOOL PRICE LIST, FOR 1894.

\*\*\*\*\*

### AMERICAN SYNDICATE OF Jewelers' Auctioneers.

ESTABLISHED for the sole purpose of conducting sales for established Jewelers in the United States, Canada and Mexico. We do not sacrifice your goods. We take no sales on a percentage. Our terms are strictly one-half the profits realized on all goods sold. We guarantee you against any loss. We pay all our own expenses; we don't ask you to pay one cent of expense on our account. We buy stocks complete as well as sell them. If your stock is small, or your assortment is not complete, we will furnish from one to ten thousand dollars worth of any kind of stock you may need and in which you need not invest one penny. Don't make any arrangements with others until you read our pamphlet which we will send you free, giving you full particulars of our style of doing business, and the liberal offers we make to Jewelers. We don't care how small your stock is, we will furnish all the stock you need to make a successful sale. We challenge the world for any fairer or more liberal propositions than we make Jewelers. Don't fail to send us your address, and we will send you our business pamphlet, which gives you full explanations as to our terms and style of doing business. Address,

### AMERICAN SYNDICATE OF JEWELERS' AUCTIONEERS.

Offices: 20 WEST 14th STREET, NEW YORK. 611 PENN AVE., WASHINGTON, D. C.

### CAMPBELL-METCALF SILVER CO.

Choice Conceits IN Sterling Silver ONLY.

TRADE MARK

2 Maiden Lane, N. Y., with Holmes & Edwards Silver Co. 66 Stewart St., Prov., R. I. Mills Bldg., San Francisco, 8th Floor, Room 1.

## "THE BEST BUTTON MADE."

THE KREMENTZ

IN GOLD

IN ROLLED PLATE

FROM

KREMENTZ & CO.

ONE PIECE

FROM

ALL JOBBERS

AND ALL JOBBERS.



### COLLAR BUTTON.

IS THE ORIGINAL ONE PIECE BUTTON.

IS STILL THE BEST AND STILL UNSURPASSED.

Sold by all wholesale dealers at manufacturer's price.

A. N. CLARK, PLAINVILLE, CONN.

### Manufacturer of the Celebrated LOOP WATCH KEY.

The Best for the Price in the World. CROSBY'S JEWELING TOOLS IMPROVED.

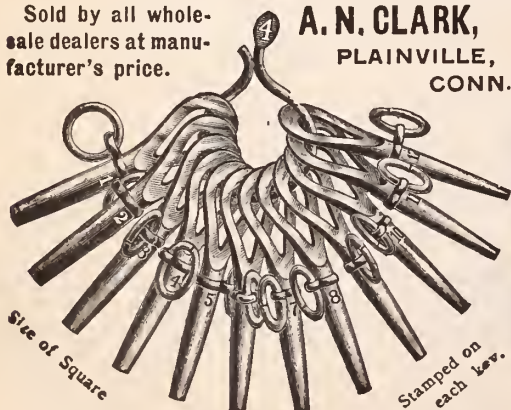

Size of Square

Stamped on each key.

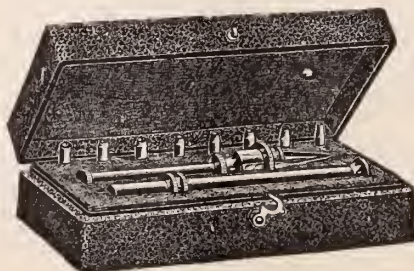

Will quote royalty or price for the manufacturing of articles of real worth.

JACOT & SON IMPORTERS AND MANUFACTURERS OF MUSICAL BOXES

39 Union Sq., New York.



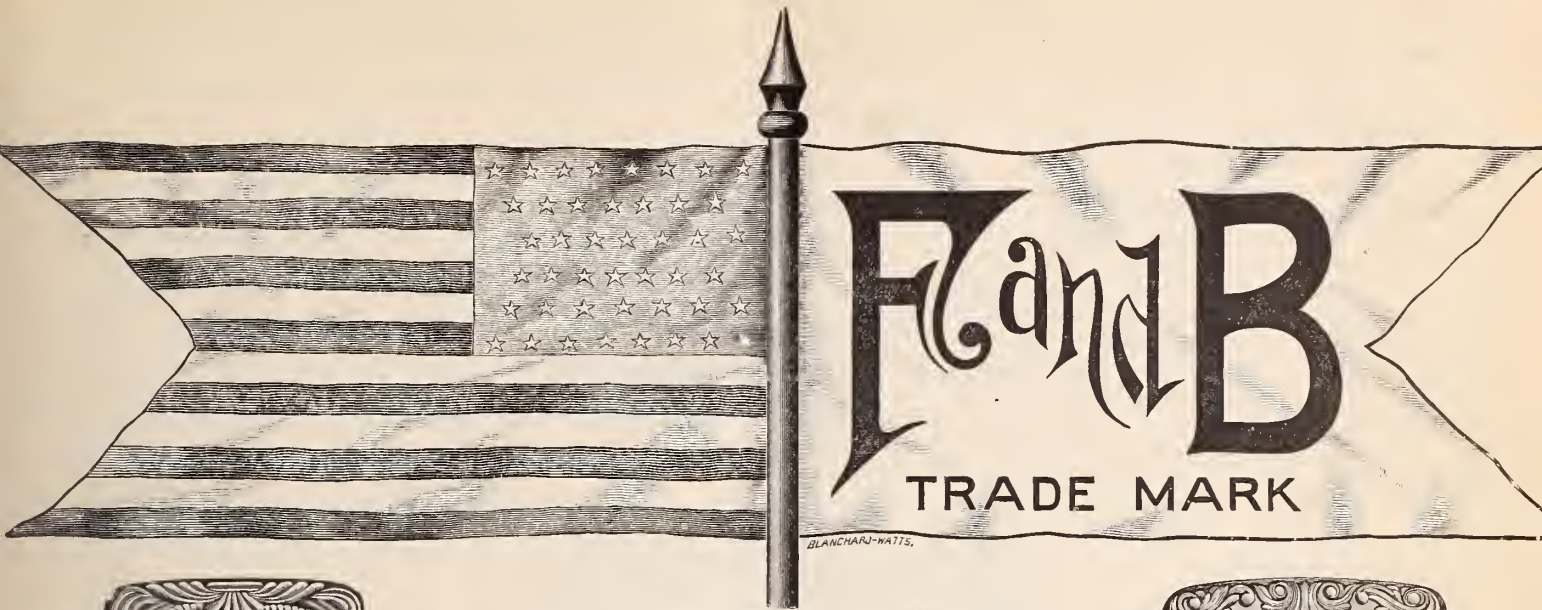

No. 1. Match Box and Cigar Cutter Combined.



No. 2. Match Box and Cigar Cutter Combined.

**W**E ILLUSTRATE OUR NEW PATENTED MATCH BOX IN STERLING SILVER 925-1000 FINE. THERE IS A SLIDING KNIFE IN THE COVER TO CUT OFF THE END OF A CIGAR, AND WORKS PERFECT, CUTTING A CIGAR CLEAN AND JUST RIGHT. THE TIP IS THROWN OUT THROUGH AN OPENING AND DOES NOT FALL DOWN AMONG THE MATCHES. THE BEST AND MOST CONVENIENT EVER MADE FOR A SMOKER.

EVERY OUNCE OF SILVER THAT WE USE, IS 925-1000 FINE.

~~~~~

**Foster & Bailey,**  
Providence, R. I.



Front View.

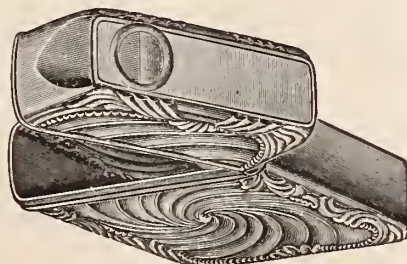

No. 2. Side View.



No. 2. Open.



appropriate to represent the *Vigilant*, ever ready to meet her challenger, than this figure of the handsome Indian woman showing so much confidence and bravery.

The vase itself which is in bright finish stands 21 inches high, and is supported by four feet representing dolphin heads. These serve to connect the beautiful chased decorations suggesting water, which ornament the bottom of the vase. Well up on the neck of the vase is the seal of the New York Yacht Club oxidized. The neck itself is fluted and treated with a heavy edge under which rest tiny shells. The bareness between the figures is relieved by a representation of water breaking upon rocks. The inscription which is etched deeply making the letters stand out in bold relief, reads as follows:

TO  
THE OWNERS OF THE  
VIGILANT  
FROM THE  
NEW YORK YACHT CLUB  
TO COMMEMORATE HER VICTORY OVER THE  
VALKYRIE  
IN DEFENSE OF THE  
AMERICA'S CUP,  
1893.

A noticeable feature of this beautiful production resides in the fact the outline of the vase is in no way strained to accommodate the figures, nor are the positions of the figures diverted in the slightest from their natural pose to support the vase. That a piece so appropriate to the great event

which it represents could be made so devoid of ordinary suggestions of things nautical, is a triumph in the designing and manipulation of the white metal, of which the makers may feel justly proud.

**The Ozark Onyx Co. Must Pay Their Subscriptions.**

ST. LOUIS, Mo., April 4.—Judge Valliant has granted the application of the Providence Jewelry Co. for a receiver for the Ozark Onyx Co., and appointed the St. Louis Trust Co. as receiver, for the purpose of bringing suit to compel the stockholders of the onyx company to pay up their unpaid subscriptions to an amount sufficient to pay the debts of the company, which assigned some time ago.

**The New York Standard Watch Co. Obtain a Verdict.**

The General Term of the New York Court of Common Pleas, has handed down its decision on the appeal by the H. B. Clafin Co. from a judgment in the City Court in favor of the New York Standard Watch Co. The action was originally brought by the H. B. Clafin Co. to recover from the New York Standard Watch Co. on a promissory note. A verdict was rendered in favor of the defendants, who had set up a counter claim. The General Term of the City Court sustained this verdict and the plaintiffs appealed again to the General Term of

the Court of Common Pleas, which in its opinion just handed down has also decided in favor of the New York Standard Watch Co., affirming the judgment with costs.

**Wants Very Large Damages From a Little Jeweler.**

DENVER, Col., April 4.—August Courvoisier, a South Denver jeweler, is defendant in a damage suit for \$30,150 instituted by E. Raymond and being heard before Judge Rising. Raymond was a special policeman for the Tramway Co., near the place where Courvoisier kept a little shop. A number of small boys were teasing him, which precipitated quite a fight. During the progress of the trouble a shot was fired which severely wounded special policeman Raymond. The latter believes that Courvoisier wounded him and is seeking pecuniary recompense for his injuries.

In securing a jury, counsel for Courvoisier created quite a surprise by asking each prospective juror if he was a member of the A. P. A. He explained that as his client was a foreigner he wanted no one on the jury who was prejudiced against foreigners. The case is still on trial.

Bracelets with oblong sections on their upper side have large colored stones, set like mosaics, among small diamonds. This is one of the most attractive of the new designs.

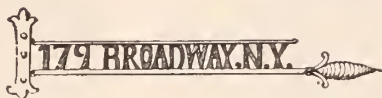
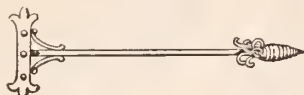

**SWELL END EYE WIRE SELLS.** WE PROTECT THE SWELL BY U. S. PATENT. The Swell also protects the retailer by NOT BREAKING. All our gold frames are BUILT THAT WAY. Look you into our A. B. SEE method of teaching OPTIX. First TUESDAY each month.



**MAIDEN LANE 15 CO. MFG. OPTICAL SPENCER.**

A Full Line  
OF ALL  
AMERICAN  
WATCHES.

**MAX FREUND & CO.,**  
Importers of Diamonds and Precious Stones,  
AMSTERDAM: 8 MAIDEN LANE,  
TULPSTRAAT 9. NEW YORK.

SPECIALTY:  
**DIAMOND  
JEWELRY**  
of our own design.

**IF YOU WANT A POSITION  
YOU NEED A SALESMAN  
YOU NEED A WORKMAN  
YOU DESIRE TO EXCHANGE  
YOU WANT A PARTNER  
YOU WISH TO SELL OUT  
YOU HAVE TOOLS TO SELL  
YOU HAVE A PLACE TO LET  
YOU WANT ANYTHING**

USE THE  
**SPECIAL NOTICE PAGE**  
OF THE  
**JEWELERS' CIRCULAR,**

Published Every Wednesday.

**THEODORE C. STEINHAUS,**  
— MANUFACTURER OF —  
**Fine Cases and Trays**  
For JEWELRY, SILVERWARE, &c.  
SAMPLE CASES AND TRAYS FOR TRAVELERS.  
Fancy Hard Wood Chests for Silverware, &c.  
Linings, Cushions, Mounting, etc., for Silver Novelties.  
**10 MAIDEN LANE, NEW YORK.**



THE  
*Pairpoint*  
 Makers and Designers of  
 "Superior" Gold  
 AND  
 Silver Plate



No. 934. RING STAND, PIN CUSHION AND TRINKET TRAY COMBINED.

MFG. COMPANY, New Bedford, Mass.

FACTORIES:

New Bedford, Mass.

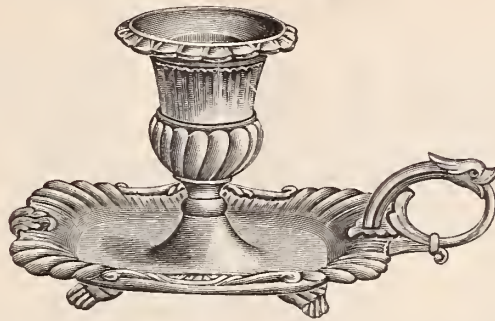

No. 6105. CANDLESTICK.

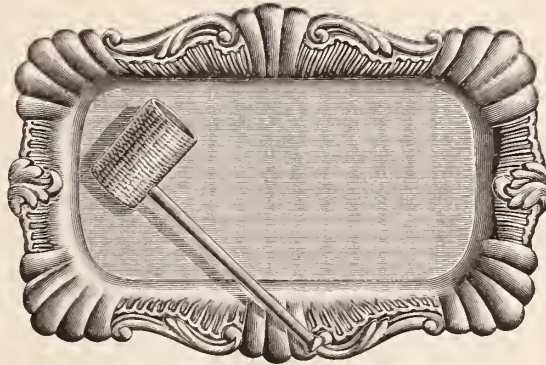

No. 1962. ASH RECEIVER.

Rich Cut Glass

AND FINE

Decorated Art Wares.

THE BEST selling goods on the market bear the stamp of.....

PAIRPOINT.



No. 3744. TOOTH PICK HOLDER.

A. J. LOGAN,  
 MANUFACTURER OF  
 WATCH TOOLS, HAIR SPRINGS AND  
 WATCH MATERIALS.  
 < New Catalogue just issued, Sent on Application. >  
 WALTHAM, MASS.

CROUCH & FITZGERALD.

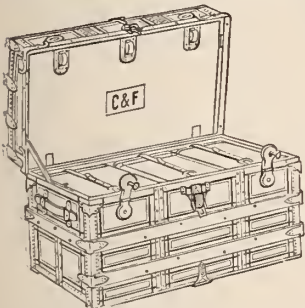

Jewelry Trunks  
 and Cases,  
 161  
 Broadway,  
 Bet. Cortlandt and  
 Liberty Sts.,  
 688 B'way,  
 701 6th Ave.,  
 NEW YORK.

PATENTS SECURED WITHOUT  
 FAIL OR DELAY.  
 Send Rough Sketch or Model and I will tell you  
 whether you can obtain a patent,  
 WITHOUT CHARGE.  
 Fifteen years' experience. Ample references. Address  
 C. T. BELT,  
 WARDER BUILDING WASHINGTON D. C.

2 MEDALS AWARDED  
 Wm. K. POTTER,  
 TORTOISE SHELL WORKS PROV. R. I.  
 AT  
 WORLD'S  
 FAIR,  
 1893.

Providence Shell Works, Providence, R. I.  
 Correspondence Invited.

We sell to the legitimate Jewelry and Stationery  
 trade only.



NEW YORK CITY U.S.A.

CHOICE PAPERS  
 MAKERS OF  
 FINE STATIONERY

For Correspondence, Wedding and Business Use, handsomely  
 boxed, specially suited to the Jewelry Trade.

18 MURRAY STREET, NEW YORK.



# R. WALLACE & SONS MFG. CO.

SILVERSMITHS

Trade Mark.

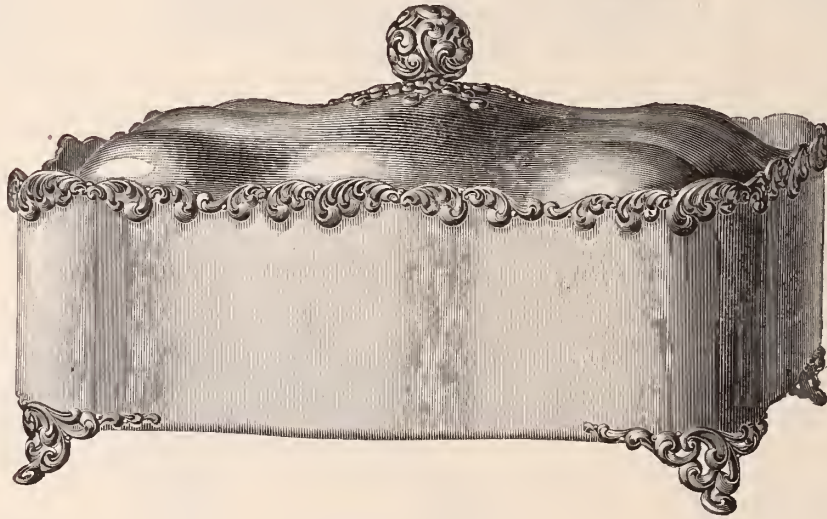

WAVERLEY SARDINE BOX.

Manufactories and  
Main Office,

WALLINGFORD, - - CONN.

BRANCHES :

NEW YORK  
3 PARK PLACE.

SAN FRANCISCO,  
120 SUTTER STREET.

CHICAGO  
86 WABASH AVENUE.



**Among the African Diamond Mines.**

PROSPECTING FOR DEPOSITS OF DIAMONDS — THE MONOPOLY OF THE DE BEERS CO. — A CASE OF I. D. B. — GREEN DIAMONDS AT KLERKSDORP — MINING AT THE RIVER DIGGINGS.

KIMBERLEY, March 1, 1894. — It is quite evident that much active and practical prospecting is going on just now. Great interest is being shown in the probability of new mines cropping up; but it must also be chronicled that little of a tangible result is apparent. Like metals, the weight of diamonds actually realized is the only result upon which a calculation of the probable value can be made. Since Dutoitspan and Buelfontein were closed to the individual digger or the small company, there has been a superabundance of mining effort on these fields and insufficient scope for the men and money on the spot. From time to time there have been reports of the discovery of payable mines, but the ultimate disclosures have not been encouraging. Today the De Beers Company is the only concern on this continent that in any way influences the supply of diamonds to the world. And the policy of the management is to keep up a firm market. That this policy does not give unqualified satisfaction to everybody here you are probably well aware. But it should be understood that nothing at present is apparent to justify the belief that they will not long retain their monopoly.

The cases of I. D. B. lately have been of a kind with which we have been quite familiar for years. The white scoundrel engages a native to deal with other natives, keeping well in the background himself, but appropriating the principal gains. Often enough the native deals illicitly for years, and exhibits a cunning that baffles the keenest detective intellect. When he does blunder or play false, the white principal has generally got wind of it and got out of reach. Occasionally, however, he is caught red handed and pays for his cupidity by a hard life as a convict. This week a German tinsmith, long suspected, has been brought to book, and on his premises was found a parcel of seventeen hundred karats in gross weight. The diamonds are not of the best quality but some idea of the profitable nature of the illicit business may be gained from the fact that the man, according to his own admission, had only expended three hundred pounds upon their acquisition. He will probably retire from public life for a prolonged period.

Green diamonds continue to be found in small quantities and of from one to three



**THE BOWDEN SEAMLESS RING**

IS MADE ONLY BY

**J. B. BOWDEN & Co.,**

Makers of Finger Rings of every Description.

**COR. BROADWAY & JOHN STREET,  
NEW YORK.**

**\$3.00**      **FORMERLY**      **\$6.00**

Ivory and Enamel Miniatures  
Best Workmanship.



Original Inventor and Patentee of  
**Miniatures**  
— ON —  
**Gold and Silver.**

**LEON FAVRE,**      **107 E. 26th Street,  
New York.**

PATENTED November 12, 1889.

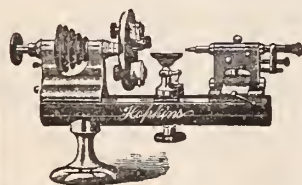

Prices of LATHES AND CHUCKS are "WAY DOWN"

All purchasers of our THREE FOUR lathes and chuck combinations now receive FREE our new TIP OVER "T. REST," on which we have patent pending. The most valuable addition to plain lathe in recent years.



SEND FOR FEB. PRICE LIST.

WALTHAM WATCH TOOL CO., SPRINGFIELD, MASS



The Roy Watch Case Co. Cases  
assay among the highest.





karats size, at Klerksdorp. They are in eager quest for export to Europe and realize from £7 to £10 per karat on the spot.

At the River Diggings there have been more startling surprises during the week. A 90 karat white gem valued at £450 has been found in an abandoned claim which had been fruitlessly worked for three months, while a large yellow diamond worth £300 has been picked up by a native from the debris. The greater part of the population, however, have very rough times and realize but little by their quest for precious stones.

More old diamond mines from which primitive tools and skeletons of men of enormous stature have been recovered, have been found near Winburg, in the Free State. Who worked these mines is still a matter of conjecture.

ST. GEORGE.

#### The Affairs of the Columbus Watch Co.

COLUMBUS, O., April 5.—Hon. George L. Converse stated to a reporter this week that in a few days he would apply to the court for an order to sell the property of the Col-

umbus Watch Co. He said he was sorry this had to be done, but that the creditors of the concern had been pressing their claims so hard that it now looked as if no other course was left open for the receiver to pursue. As attorney for the receiver he had tried to stave off this proceeding in hopes of effecting a reorganization. Several plans had been talked over for reorganizing the company and inducing new capital to enter the enterprise, but he feared that the end was not in sight.

There is an issue of \$35,000 of bonds secured by the real estate owned by the company, and the bondholders will not lose their money. The real estate will be sold to pay this claim and the balance go to the general creditors. Mr. Converse said the outlook for reviving this industry had been good until recently, when creditors grew clamorous, and as a result scared those who were thinking of taking stock.

A few days ago an application was made to sell the finished work at the appraised value, and now the whole plant would have to be sacrificed. On last Monday the Dresher National bank was given a check by Sheriff Ross for over \$20,000 to pay one of the claims of the bank, and others will quickly follow. Mr. Converse thought a meeting of the Board of Trade should be called with a view to interesting men in the enterprise. The order to sell the property will be taken in a few days unless something is done in the way of reorganization. Those who were trying to effect a reorganization had secured about \$65,000 for the purpose.

#### Failure on the Rialto of New York.

Julius Asher, jeweler and diamond setter, 105 E. 14th St., New York, made an assignment Tuesday, April 3d, to Seaman Danziger, without preferences. Mr. Asher lives at 134 E. 117th St. He has been in the jewelry business about twenty years. He failed before in January, 1881, for \$7,000, and compromised at 25 per cent.

The attorneys for the assignee, Wise &

Lichtenstein, estimate the insolvent's present liabilities at about \$6,000.

#### A Decision in The Philadelphia Optical & Watch Co. Litigation.

PHILADELPHIA, Pa., April 5.—By a decision of the Supreme Court, set out in an opinion by Justice Fell, the ruling of Common Pleas Court No. 3, in the case of the Pairpoint Mfg. Co. and others against the Philadelphia Optical & Watch Co. and others is reversed.

The Keystone Watch Case Co. on Jan. 10, 1894, secured a judgment of \$50,000 against the Philadelphia Optical & Watch Co., on which an execution was issued and a levy made. Receivers were subsequently appointed and a sale under the execution was stayed, based upon the argument that as the optical company was a New Jersey corporation, the optical company perpetrated a fraud upon other creditors by confessing the judgment in favor of the Keystone Watch Case Co., such confession being forbidden by the New Jersey law. No such legal restriction obtains in this State.

In deciding against this contention Justice Fell says: "No disability to make a preference is imposed upon this corporation by its charter, and the prohibition by a general enactment can have no extra territorial effect. Not being forbidden by the organic law of the corporation, the legality of the act must depend upon the law of the State where it is done; in Pennsylvania an insolvent corporation may prefer a creditor by a confession of judgment.

"The confession of this, then, being lawful, the assignment of error is sustained and the decree of the Court of Common Pleas of February 16, 1894, is reversed and set aside, with costs to be paid by the appellees."

B. D. Ward, watchmaker at Waltham, has started for Honolulu, having secured a position with a leading jewelry house there.

## SILVER Deposit Cologne.

PURE SILVER <sup>1,000</sup>/<sub>1,000</sub> FINE.



\$3.50

EACH.

No. 223.

ALVIN MFG. CO.,  
860 BROADWAY, NEW YORK.

## GOOD TIMES ARE COMING.

Enliven your stock and set the ball rolling by putting in a line of the new "CHARMILLES" watch.

HIGHEST ART,

GREATEST VALUE,

LEAST MONEY.

FOR PARTICULARS AND PRICES ADDRESS YOUR JOBBER.



**A Committee Will Investigate John B. Yates' Affairs.**

About 25 creditors representing the greater part of the indebtedness of John B. Yates, jobber in watches, 21 Maiden Lane, New York, who assigned March 22 to John B. Brown, met at the office of the Crescent Watch Case Co., 21 Maiden Lane, Friday afternoon. Mr. Yates, his attorney, and the assignee were also present.

After clearing the room of reporters and assuring himself that none but creditors were present, Assignee Brown read a statement which showed Mr. Yates' liabilities to be \$58,935, of which \$37,055 was due on notes, the rest being for merchandise. The assets nominally were \$19,717, their actual value being about the same, something over \$19,000. They consisted of stock, accounts and \$900 in cash—a fact which the assignee called attention to as unusual.

In the course of his remarks Mr. Brown stated in substance that Mr. Yates had looked more to the volume of business done than to the amount of profit accruing, and had transacted a large business on a very close margin. Questions by the creditors in regard to the way the business was carried on, the volume done, etc., were answered by Mr. Yates. After a short discussion on the motion of Daniel F. Appleton an investigating committee of three were appointed to make an examination of the insolvent's affairs and report at a future meeting. The committee consist of F. R. Simmons, of Henry Ginnel & Co., chairman, Irving Smith, of the Crescent Watch Case Co., and Mr. Mason, of N. H. White & Co. The meeting then adjourned.

Among the principal creditors represented at the meeting were: Crescent Watch Case Co., \$8,385; Henry Ginnel & Co., \$8,851; N. H. White & Co., \$12,177; Seth Thomas Clock Co., \$6,524; Robbins & Appleton, \$6,067; Bates & Bacon, \$688; Brooklyn Watch Case Co., \$1,708; Fourth National Bank, \$2,000; Courvoisier-Wilcox Mfg. Co., \$492; Roy Watch Case Co., \$273; The Jewelers' Circular Pub. Co., \$136; Stanley Bros., \$303; Carter, Sloan & Co., \$195.

**Death of Zeno Kelley.**

FALL RIVER, Mass., April 9.—Zeno Kelley, formerly of the firm of Lincoln & Kelley, dealers in watches, jewelry, &c., in this city, died at his residence in South Yarmouth, Mass., April 4, of consumption. He had recently returned from Aiken, S. C., where he had been for his health.

Mr. Kelley was about 52 years of age, and had carried on the jewelry business in South Yarmouth for several years.

**Are These the Men Who Robbed H. C. Barnum of His Trunk?**

SPRINGFIELD, Mass., April 8.—The police think that the thieves who made off with the trunk of goods of H. C. Barnum, of Shafer & Douglas, New York, in January, have been captured. Yesterday two men, giving their names as Henry Parker and Samuel Goodman, were arrested in Rochester, N. Y., by Detectives Kavanagh and Furtherer, and in their possession was about \$400 worth of diamond, sapphire and ruby rings. Mr. Barnum happened to be in Syracuse and he went to Rochester last evening, and identified the rings as a part of his stock.

To-night City Marshall Rice will leave this city for Rochester, and will take with him the night clerk of the hotel where the robbery was committed, and will try to identify the men. If they prove to be the ones, extradition papers will be secured and they will be brought to this city for trial.

The history of the case is fresh in the minds of the readers of THE CIRCULAR, but it might be well to give it a passing mention. Last January H. C. Barnum came to this city and left his trunk in the baggage room at the depot. Before retiring for the night he saw that his trunk was all right. Early the next morning, however, when he went for it the trunk was gone and he finally located it at the Glendower hotel where someone had taken it after working a duplicate check racket on the baggage-man. Nearly every ring which the trunk contained was gone, the thief having taken one of the leather compartments in which to carry his plunder.

The next day the police located a large quantity of the rings at Worcester and recovered them. It was said that the property recovered figures about \$18,500 and that the original loss was \$22,000.

MR. BARNUM IDENTIFIES SOME OF THE STOLEN GOODS.

SYRACUSE, N. Y., April 9.—Herbert C.

Barnum lives in this city, at 803 University Ave. He had reached Syracuse on his route Saturday when he received a telegram from Rochester requesting him to go there immediately as the police had arrested two men whom they thought were connected with the stealing of his trunk of samples from the Boston and Maine baggage room in Springfield, Mass. The men gave their names as Henry Parker and Samuel Goodman and were attempting to dispose of considerable jewelry at different pawn shops when arrested.

Mr. Barnum hastened to Rochester and identified the jewelry as part of \$22,000 worth stolen from his trunk at Springfield.

**A Mysterious Robbery at A. Paltowitz' Store.**

ELMIRA, N. Y., April 10.—The police department was notified Monday morning, by a son of A. Paltowitz, that his father's store had been entered sometime Sunday night, and \$80 had been stolen from the safe. The son could not state whether or not the safe was locked Sunday night or left open.

The police investigated the case, and could not find any trace of where burglars had effected an entrance to the store. The windows were all found securely fastened, as also the door leading into the street. The door leading from the store into the cellar was found unbolted, but the police say no one could have entered the cellar, as the windows were all nailed shut. In the safe from which the money is claimed to have been abstracted was several thousand dollars worth of diamonds, watches and jewelry, but these were all intact.

The robbery is certainly a mysterious affair. A. Paltowitz, the proprietor, left for New York Sunday night to purchase goods.

When the judgment is weak the prejudice is strong.—O'Hara.

No one who cannot master himself is worthy to rule.—Goethe.

**Rice & Hochster**  
 TRADE MARK  
 Manufacturers of  
**TORTOISE SHELL GOODS**  
 485 BROADWAY, - NEW YORK.

The best Trade use the **ROY** Watch Case Co. Cases.



### Daniel B. Spear Dies After Years of Suffering.

BOSTON, Mass., April 9.—The death occurred yesterday morning at 1.30 o'clock of Daniel B. Spear, in the 54th year of his age. He was the senior partner in the firm of H. T. Spear & Son, having been associated since the death of his father with Austin T. Sylvester, his brother-in-law, in the jobbing house at 370 Washington St.

Mr. Spear had been a sufferer for 14 years from a spinal difficulty that would have caused a less determined man to succumb in much less time. An attack of the grip with which he was prostrated just before Christmas, weakened him so completely that his iron will was unable to overcome the effects and he had been confined to his house since that time.

A quarter of a century ago Daniel B. Spear was one of the most active men in the Boston jewelry trade. Soon after attaining his majority he was admitted to partnership by his father, the late Henry T. Spear, and until his health was undermined in the early seventies he was an energetic business man. Of late years, however, the contrast has been more than sad for his friends to realize. Slowly but surely day after day his power of muscular control diminished, although his wonderful tenacity of purpose and strong mentality for years after he had ceased to get about unassisted, enabled him to ride down to the firm's place of business daily and remain there during the busiest part of the day.

In his younger days Mr. Spear joined the Masonic fraternity, and was also a member of Siloam Lodge and Trimount Encampment, I. O. O. F. In religious belief he was a Universalist. He leaves a wife.

The funeral will take place from his late residence, corner of Massachusetts Ave. and St. Botolph St., to-morrow, and will be attended by representatives from nearly all the prominent Boston firms. Deceased was widely known, and much esteemed by the trade.

### Jeweler Harris Successfully Plays Detective.

WILKESBARRE, Pa., April 6.—Isaac K. Harris, one of the proprietors of the jewelry store at 79 Public Square, performed a neat bit of detective work, which resulted in bringing back some jewelry that would otherwise have been lost. Monday evening he missed two watches—one a cheap and the other an expensive watch. He ran over in his mind who had been in the store during the evening, and his suspicions fell upon a woman. He urged her to go back to the store under some slight pretext, but before she arrived he secreted a boy who works in the store in a large unused show case covered with a cloth. On the woman's arrival he seated her near the case and then told her of his loss and suspicion.

"Now, I'll tell you what I will do," said Mr. Harris. "I care nothing about the expensive watch, but the cheaper one is an

heirloom in a family of this city, and the gentleman who owns it threatens to bring an action for \$200 damages against me if I do not secure its return. Now, if you will return the watch, I will give you this ten-dollar bill." Mr. Harris handed the bill to the woman, and she left the store promising to return the watch in a few minutes. True to her word, when she came back in a short time she handed the watch to the jeweler.

"Now," said Mr. Harris, "I have another proposition to make. 'If you will return the companion of this watch which you also stole, I will not have you arrested. But if you refuse, I shall certainly send for an officer and have you sent to jail.'"

"You can do nothing of the kind," replied the woman, "for you have no proof that I stole the watches, or returned the one you hold in your hand."

"Haven't I," replied Harris. "Look here," and he drew the covering from the show case, and the boy stepped out. Of course when the woman saw this proceeding she wilted, and in a short time thereafter she had the other watch back to the store, and apparently was very happy to get out of the scrape so easily.

Henry Sonneman, a jeweler at 46 S. Pearl St., Albany, N. Y., was found unconscious in his store by the police Thursday night. He was suffering with euraema and was taken to the City hospital.

### A Jewelry Traveler Locked up on a Girl's Complaint.

PITTSBURGH, Pa., April 9.—Benjamin Henschell, a traveler for the Philadelphia jewelry house of Wm. Morris & Co., was arrested in this city Friday evening on a warrant sworn out by George Steiner, the brother of a Philadelphia girl whom Henschell is accused of having wronged. Henschell heard that Steiner was hunting him with a gun and went to police headquarters to ask protection. A warrant was waiting for him there, and Detective Robinson protected Henschell by putting him into the Central station.

The young man is well-known in this city and many friends applied for permission to see him Friday night. Yesterday morning \$500 bail was required which was quickly secured and Henschell released. At the evening hearing the prosecution was not ready, and Henschell gave bail for a further hearing next Friday evening.

A few nights ago at Beech Creek, Vt., burglars broke into Smith's jewelry store and stole jewelry amounting to about \$200. The thieves pried open the front door of the store. It is supposed that the thieves were two tramps who had been loitering around the town for a few days prior to the robbery.

Worth begets, in base minds, envy; in great souls, emulation.—*Fielding*.

## Sterling Silver Match Boxes

WITH CIGAR CLIPPER ATTACHMENT.

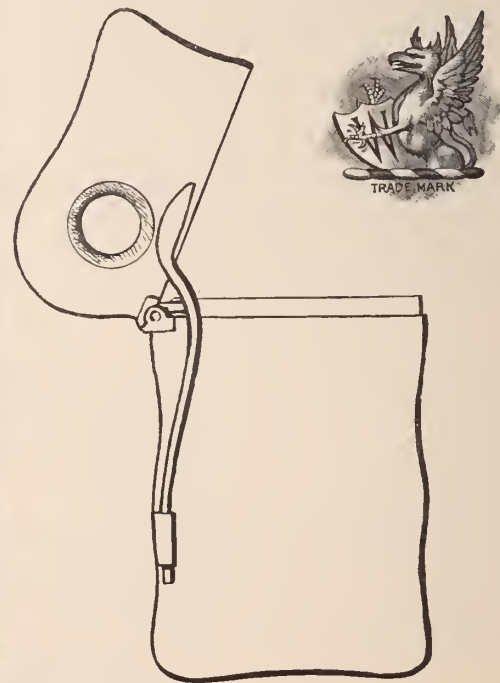
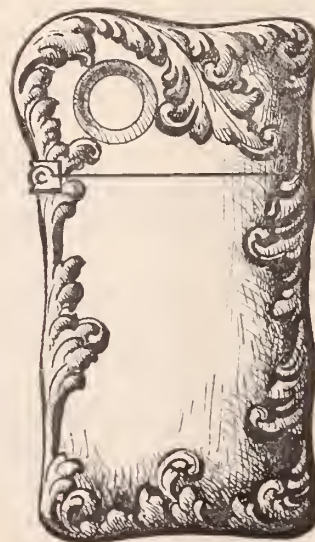

PLAIN OR FANCY.

**F. M. Whiting & Co., = NORTH ATTLEBORO, MASS.**

Sterling Silver Hollow ware, Flatware, Novelties, Toilet Articles, &c.

NEW YORK OFFICE, 857 Broadway.

AFTER MAY 1, 1128 B'way & 208 Fifth Ave.

HANDSOME NEW CATALOGUE SHOWING 22 PATTERNS IN TEAS, AND 36 PATTERNS IN COFFEE SPOONS, WILL BE MAILED ON APPLICATION.



### Hon. Samuel Simpson Dies on His 80th Birthday.

WALLINGFORD, Conn., April 9. — Hon. Samuel Simpson died at his residence on Main St. shortly after 3.30 Saturday morning after a long and painful illness. That day was the anniversary of his birthday and he lived to realize that he was 80 years of age. Mr. Simpson has been afflicted with a cancer for a number of years and for the past six months has rapidly failed; he suffered excruciatingly until death relieved him this morning. By the death of Mr. Simpson one of Wallingford's most prominent figures has been removed and the town is in mourning. He leaves a large fortune and his only relatives are his wife, one daughter, two grandchildren and one great-grandchild.

Samuel Simpson was born in this town April 7, 1814, and has for about 30 years resided on Main St., and for over half a century he has been known as one of the most prosperous and prominent business men of the place. He has been honored for his business thrift, foresight and ability and for his high character and integrity. He inherited these qualities, but not wealth nor social eminence. His parents were estimable people who gave to the society of their day a quality of excellence and solidity. In 1806, like many other Connecticut farmers, they purchased land in the Western Reserve in Ohio, but remained there only five years, returning at the end of that time to Wallingford.

Mr. Simpson was the youngest of seven children and at the age of 11 years went from home to work for a physician as office and chore boy, but remained in the employ of the physician but two years as it was evident that he had no taste for the profession. At 15 years of age he was apprenticed to Chas. Yale, of Yalesville, for a term of five years. At the expiration of this time he became a journeyman and soon afterwards foreman, the business being the manufacture of britania ware. He continued in this position until Jan. 1, 1835, when by dint of economy he had saved about \$200.

Mr. Simpson was now ready for an independent business and in partnership with another purchased Mr. Yale's britania ware industry. In 1847 he sold out his britania and tin ware business and soon after purchased the old flouring, wool carding and cloth dressing mills near the Quinipiac river, known as the Humiston mills and fitted up the premises for the manufacture of electro silver plated ware. On Jan. 1, 1854, this industry was merged into the Meriden Britannia Co., then but one year old. Mr. Simpson became one of the directors and largest stockholders of the company. Soon after he formed a partnership with the late Robert Wallace under the name of R. Wallace & Co., for the manufacture of nickel silver spoons and forks. In 1860 Mr. Simpson and Mr. Wallace formed a joint stock company with the firm title of Wal-

lace, Simpson & Co., with a capital of \$100,000. Mr. Simpson became its president. The next year Mr. Simpson organized a new company with the firm title of Simpson, Hall, Miller & Co., and began business on the east side of the town. Mr. Simpson was elected president of the new company and retained that position up to the time of his death. In 1871 he sold his interest in the Wallace, Simpson Co., to his partner and organized the Simpson Nickel Co., with premises south of the railroad depot. He was elected president of this company also, and has held the position since that time.

Mr. Simpson was largely instrumental in establishing the Dime Savings Bank in 1871 and has since that time been its president. In 1881 the First National Bank was chartered and he became its president. He was also a stockholder and director in the Meriden National Bank. Mr. Simpson's political affiliations were always with the Democratic party and he has filled many offices of trust in the town besides representing the same in the Legislature in the years 1846, '59, '65, and '69. He had also filled the position of Senator from the 6th district, and served his party in its most prominent councils both State and National.

Mr. Simpson was an Episcopalian and almost a life time member of St. Paul's church, Wallingford. For more than thirty years he was the senior warden of the church, and during all his life a liberal supporter of the church. His wisdom and devotion have borne the affairs of the parish through periods of serious difficulty and embarrassment. His generous feeling has been known throughout the parish and the town, and the poor and the suffering have received much relief from his warm hearted charity. His wealth and influence seemed to him to be sacred trusts, and he ever seemed to bear before him the thought that he must so live as to give a good account of his stewardship.

Mr. Simpson was fortunate in choosing a kindred spirit for his companion in life, in Miss Martha De Ette Benham, of Cheshire, Conn. They were married July 6, 1835. She was the daughter of Joseph Benham, whose ancestor of the same name was one of the original "planters" of Wallingford. Six children were born to them, Samuel Augustus, George William, Elizabeth Matilda, Martha De Ette, Willis Duryea and Samuel George. The only surviving child is Elizabeth Matilda, wife of Gurdon W. Hull.

Mr. Simpson's wealth is conservatively estimated at half a million dollars. He was elected president of the First National Bank when it was incorporated in 1881, and had held the office until two years ago, when he declined re-election and Col. W. J. Leavenworth was elected to the position. He was one of the 24 corporators of the Dime Savings Bank in 1871, and the tenth one of them to die since that date. The directors of the First National Bank and the Dime Savings Bank held meetings

to-day and adopted resolutions in tribute to the high character, worth and usefulness of the deceased.

The funeral services will be held to-morrow afternoon at 2.30 o'clock at St. Paul's Episcopal Church.

Mr. Simpson had for many years been a sufferer from a cancerous trouble on the face, which finally sapped his vital powers and caused his death. He had spent much time and money in a fruitless attempt to effect a cure of the malady. For many weeks before his death he was confined to his home and his death hourly expected; but through all he showed a remarkable tenacity in his hold on life and a marked spirit of resignation in suffering. Although his death had been expected, it casts a gloom over the entire community in which he had so long moved—a man prominent and leading in business and a benefactor to the community.

### The Crescent Watch Case Co. to Operate a Factory in Canada.

The Crescent Watch Case Co., of Newark, N. J., contemplate starting a watch case factory in Montreal, Canada, to run in conjunction with their factory in Newark. Representatives of the company are expected in Montreal this week to make arrangements for the new concern.

Irving Smith, treasurer of the company, who was seen at the New York offices, 21 Maiden Lane, Monday, told a CIRCULAR reporter that the foregoing statement was practically correct. The company, he said, believed that they could manufacture cases as cheap in Montreal as in Newark, and by having a factory in Canada could supply the trade of that country and avoid the duty of 35 per cent. which they now have to pay on the watch cases which they export.

The Montreal factory will be run by a separate company known as the Crescent Watch Case Co. of Canada, but this company is practically part of the Newark concern, as both are under the control of the same stockholders.

### Creditors of Benj. S. Wise & Co. Form a Corporation.

Benj. S. Wise & Co. were incorporated last week with a capital stock of \$40,000. The directors who are among Mr. Wise's principal creditors are Hyman Hein, Frances Hein and Joseph L. Hein, and are relatives of Mr. Wise's wife.

In his statement to a CIRCULAR reporter at the time of his failure, Mr. Wise said that if his offers of settlement were not accepted, his principal creditors would form a stock company to continue the business, and make him its manager. This is presumably what has been done, as one of Wise's large creditors told a CIRCULAR reporter that none of the proposed settlements had been effected.

The store of the company, the reporter was informed, was open for business Thursday, but was closed the following day.



### A Sensational Episode in the Affairs of Jeweler C. D. Platt.

LOS ANGELES, April 2.—One of the most sensational arrests ever occurring in Los Angeles was that last week of C. D. Platt, jeweler, upon a charge of blackmail, and this was followed by an information filed against Platt, by the United States District Attorney, charging him with fraudulent uses of the United States mail. Up until a few weeks ago, Platt and W. T. Harris were conducting a jewelry store on the northwest corner of Main and 1st Sts. Platt had been doing business there for about five years. He is said to have sold out his interest in that business to Harris and since then has been doing nothing.

With Platt there was arrested a detective named Emil Harris who has been running a business here, called the California State Detective's Agency. It is charged that Platt and Harris conspired to blackmail a man named Crandall, who was, until recently, a hardware merchant here, and who is now being sued by his wife for divorce.

About five years ago Platt, with a partner, conducted a jewelry business in this city. They failed and their creditors believed they had held out about \$25,000 of stock. Detectives unearthed a large quantity of set goods and arrested Platt. When searched in jail a silver snuff box was found in the palm of one of his hands which he had carelessly drawn out of his pants pockets and

held behind him during the process of searching. In this snuff box was found \$4,000 of loose diamonds. There was also found on Platt at this time a list of the stock held out and the division which had been made of it between him and his partner. This list was in his own handwriting. When he was on the stand it was handed to him by counsel on cross examination and he was asked "if he had ever seen it before." Platt's lawyer interposed an objection upon which argument ensued and while attention was thus diverted Platt crumpled up the paper, put it in his mouth and swallowed it.

The charge against Platt in that case was "fraud against creditors." The jury disagreed and he was released. Eleven of the jurors stood for conviction. Platt has had a number of judgments against him ever since, but with all this he has managed to keep the store at Main and 1st Sts. until he sold out to W. T. Harris, who was formerly of Harris & Dukeman.

### Rosenstihl Bros.' Store Opened by the Receiver.

BIRMINGHAM, Ala., April 8.—J. B. Cobbs, receiver for Rosenstihl Bros., has reopened the firm's store for the purpose of selling their stock of goods and arranging their affairs with their creditors. Rosenstihl Bros. had a nice stock of goods all of which will be sold by the receiver.

### Last Rites in Honor to Richard N. Peterson.

Among the friends, relatives, and business associates gathered at the bier of the late Richard N. Peterson, New York, were many who by their presence at these last sad rites, betokened the esteem and honor in which the deceased was held. The services took place Wednesday morning at St. Thomas' Church, 53d St. and 5th Ave., New York, the pall bearers being William Moir, Chas. T. Cook, David C. Dodd, Geo. C. White, W. B. Baldwin and Mr. Sutton.

Other representatives from the jewelry trade present were: Morris Bruhl, D. F. Appleton, A. K. Sloan, Mr. Hedges, A. W. Sexton, Jos. F. Chattellier, Jno. A. Riley, L. J. Mulford, Leroy W. Fairchild, Miss Walker and E. C. Fitch. The interment took place later at Evergreen Cemetery.

### Late Providence Notes.

Charles F. Irons, of Irons & Russell, has returned from a visit to Cuba.

Mr. Wood has resigned his position as bookkeeper with Lothrop & Livesey.

S. & B. Lederer have purchased a valuable piece of real estate on Fountain St., at auction last week for \$9,550.

Chas. B. Brooms has severed his connection with Allen & Jonnassohn after a year's service as traveling salesman.

W. J. Braitsch & Co., of this city, are now represented in the south by Cooper & Forman, of 3 and 5 Maiden Lane, New York.

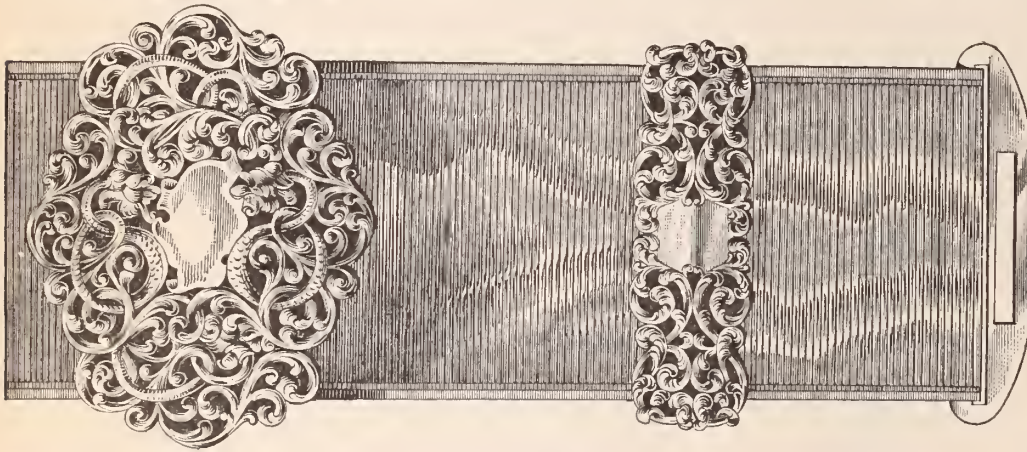

No. 9923.

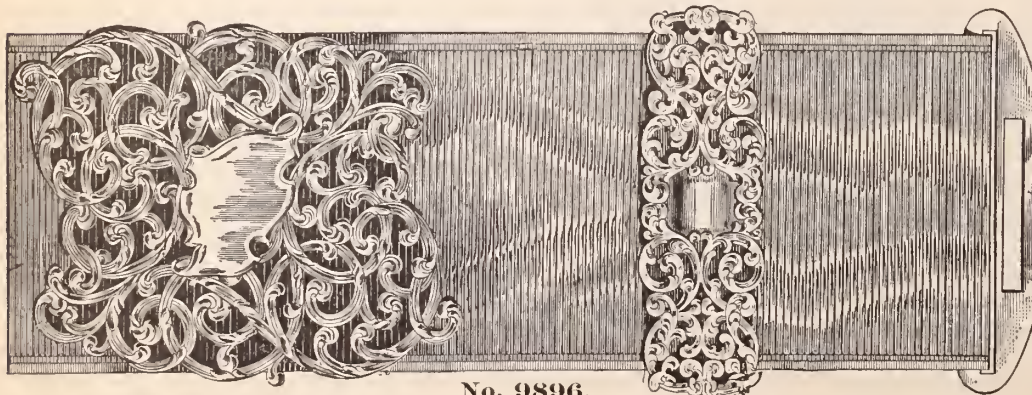

No. 9896.

## Sterling Silver Belts.

**WE STILL HAVE SOME MOIRE ANTIQUE BELTING, WHILE IT LASTS WE WILL CONTINUE TO FILL ORDERS AT PRICE CHARGED FOR PLAIN, BUT WE CAN NOT GUARANTEE TO DO THIS AFTER THE SILK WEAVERS' STRIKE IS ADJUSTED AS THE MARKET IS ABSOLUTELY BARE OF THESE GOODS.**

**WE** beg to acknowledge the request of our customers asking us to discontinue quoting prices on goods advertised in the Trade Journals. After this issue we will only quote prices when we deem it necessary to protect a pattern.

**UNGER BROS.,**  
192 BROADWAY,  
NEW YORK.



# The Jewelers' Circular

AND  
HOROLOGICAL REVIEW.

PUBLISHED EVERY WEDNESDAY BY  
**THE JEWELERS' CIRCULAR PUB'G CO.,**  
189 BROADWAY, NEW YORK CITY.

A JOURNAL DEVOTED TO THE INTERESTS OF  
JEWELERS, WATCHMAKERS, SILVERSMITHS,  
ELECTRO-PLATE MANUFACTURERS, AND ALL  
ENGAGED IN KINDRED BRANCHES OF INDUSTRY.

Our Editorial columns will contain our own opinions only, and we shall present in other columns only what we consider of interest or value to our readers. Advertising matter will not be printed as news.

Advertising rates in THE CIRCULAR are lower, considering the number of tradesmen reached by its large circulation, than in any other jewelry journal.

Notices of changes in standing advertisements must be received one week in advance; new matter can be received up to Monday.

## INFORMATION FOR SUBSCRIBERS.

### Terms of Subscription, Postage Prepaid.

|                                              | PER ANNUM |
|----------------------------------------------|-----------|
| United States and Canada, . . . . .          | \$2.00    |
| Foreign Countries in Postal Union, . . . . . | 4.00      |
| Single Copies, . . . . .                     | .10       |

New subscribers can commence at any time. Payments for THE CIRCULAR, when sent by mail, should be made in a Post-Office Money Order, Bank Check or Draft, or an Express Money Order or Registered Letter. All postmasters are required to register letters whenever requested to do so.

Pay money only to authorized collectors having proper credentials. Returning your paper will not enable us to discontinue it, as we cannot find your name on our books unless your address is given.

In changing address always give the old as well as new one. Your name cannot be found on our books unless this is done.

We will continue to send papers until there is a specific order to stop, in connection with which all arrearages must be paid; but such an order can be given at any time, to take effect at the expiration of the subscription. All such orders will be promptly acknowledged by mail.

The Courts have decided that all subscribers to journals are responsible until arrearages are paid in full and an order to discontinue has been received by the publisher.

Member of the American Trade Press Association.

VOL. XXVIII. April 11, 1894. No. 10.

### Sterling Silver **S**IMULTANEOUSLY Legislation. in a number of States

agitation is going forward for the enactment of laws making it illegal to mark silverware as sterling unless it is of the established standard of fineness, 925/1000. The New York Legislature is considering such a bill, and Massachusetts is about to have a law providing a penalty for the fraudulent stamping of silver goods. In Rhode Island manufacturers are prohibited from using less than 925/1000 of pure silver in sterling products, and buyers of silver bearing the sterling stamp of any of the companies of that State have what is equivalent to a guarantee that the articles are as they are represented. In New York State it is proposed to make the dealer share the responsibility with the manufacturer, the person selling "coin silver" below the fineness of United States silver coin being liable to prosecution. Dealers, under these conditions, will hereafter be able, therefore, to form a correct idea of

what they are getting, though it may be added that without a law nothing would be sent from the principal silverware factories, each of which is proud of its reputation, which would be an imposition upon the public. But uniformity in State legislation is for the interest of the buyer, and also of the lesser known manufacturers, whose marks thus will be made as good as those of the large companies so far as they relate to the quality of the silver.

### Collecting Debts **T**HE Postmaster by Postal Cards. General has

given an opinion on the matter of endeavoring to collect debts by the sending of postal cards, which is certain to be of interest to every business man. Two postal cards were submitted to him. On one was written: "Please call and settle account, which is long past due and for which our collector has called several times, and oblige." The other contained these words: "You owe us \$1.80. We have called several times for same. If not paid at once we shall place with our law agency for collection." The Postmaster General, on the decision of an eminent judge, stated that the first card was mailable and that the second was not. The logic of this decision is that when a threat, direct or implied, is written upon a postal card, the card is unmailable.

**S**TYLES in dress, furniture and even jewelry are gradually going back further and further in the centuries for their prototypes. Some jewelers are fervently hoping that the styles prevalent in France in the 10th century might be revived. Judith, wife of Caipuchin, wore a girdle of solid gold weighing four pounds, and all the female votaries of fashion followed her example. If the 400 and the lower circles of society resuscitated this fashion, would the jewelry business be brisk? Maybe.

### The Annual Meeting of the Retail Jewelers' Association of Alabama.

BIRMINGHAM, Ala., April 8.—The Retail Jewelers' Association of Alabama will hold their annual meeting in Birmingham on the 25th inst. The Confederate Veterans' Reunion will be held here on that date, and as the railroads have made cheap rates to this city, and as many jewelers will be here to attend the reunion, this time was selected as propitious for the jewelers' convention. The attendance in view of these circumstances promises to be the largest in the history of the organization.

There are now between 50 and 60 members in the association, and the outlook is that a number of new members will be added at the forthcoming meeting, the official call for which will be issued by Secretary Rosenstihl in a few days.

There are many matters of importance to come before the meeting which will be detailed later.

### The Week in Brief.

**T**HE death occurred of Hon. Samuel Simpson, of Simpson, Hall, Miller & Co.—A meeting of the creditors of John B. Yates, New York, was held—The thieves who robbed H. C. Barnum, traveler for Shafer & Douglas, New York, of a trunk of jewelry, were supposed to have been captured—Jesse Collom, Minneapolis, Minn., assigned—The Valentine, Linsley Silver Co., of Wallingford, Conn., organized—S. & D. D. Gutman, Rochester, N. Y., are asking for an extension—Several jewelers of Providence, R. I., were elected to the General Assembly of the State—The store of David Gudkin, Ansonia, Conn., was invaded by burglars—The Treasury Department issued its monthly comparative statement of imports and exports—The case of Sherman & Crowley against the Ernst Schall Co., Hartford, Conn., over a check, was tried—The store of Orr L. Keith, West Branch, Ia., was burglarized—The store of Anton Bussman, Lancaster, N. Y., was burned out—The store of C. M. Brown, Greensboro, N. C., was plundered—Milton Meyer & Co., Trenton, N. J., assigned—The store of H. Solfen, Cuero, Tex., was burned out—Deal Bros.' store, Carthage, Mo., was burned out—George L. Converse will apply for an order to sell the property of the Columbus Watch Co.—Julius Asher, New York, made an assignment—The store of Wineberg & Heyman, Little Falls, N. Y., was burned out—The stock and fixtures of F. G. Smith, Sons & Co., Detroit, Mich., were sold—The stores of E. L. Penner and J. J. Gray, Barry, Ill, were burned out—Execution was issued against the H. M. Betz Watch and Jewelry Co., Philadelphia, Pa.—Warrants of arrest were issued for the members of the firm of L. H. Goldsoll & Bro., Cleveland, O.—The death occurred of Zeno Kelley, South Yarmouth, Mass.—An interesting decision was rendered in the litigation consequent to the failure of the Philadelphia Optical & Watch Co., Philadelphia, Pa.—Several persons connected with the Crescent Watch Case Co. will start a watch case factory in Canada—Creditors of Benj. S. Wise & Co., New York, formed a corporation—Moses Straus, Brooklyn, N. Y., had an interesting encounter with a swindler—The store of Lyke & Edmunds, Rochester, N. Y., was burglarized—The death occurred of Daniel B. Spear, senior partner of H. T. Spear & Son, Boston, Mass.—The death occurred of Alexander Krailsheimer, formerly of New York—Customs officials summarily seized a quantity of curios and works of art contained in the store of C. W. Schumann's Sons, New York—A mysterious robbery occurred in the store of A. Paltrowitz, Elmira, N. Y.

The inventory of the assigned estate of J. Albert Koons, Philadelphia, Pa., filed in the Common Pleas Court, show assets of \$1,107.57.



**New York Notes.**

Chas. V. Peyn, 12 John St., will remove May 1st to 10 John St.

A judgment for \$462.26 has been entered against Henry Blog, by R. Lewisohn.

Rubenstein Bros., 48 Maiden Lane, will soon open a branch store in Williamsport, Pa.

Max J. Lissauer, of Lissauer & Co., is one of the members of the April Grand Jury.

R. A. Breidenbach has entered a judgment for \$384.98 against Adolph and Peppi Duckler.

Henry Tilden, of the Tilden-Thurber Co., Providence, R. I., sailed for Europe Saturday, on the *Saale*.

The Edwin Want Optical Co. will remove May 1st from 12 John St. to the Downing building, 106 Fulton St.

Eugene Friedberger, jobber in watches and jewelry, removed Monday, from 10 John St. to 11 Maiden Lane.

Judgments against Edwardo Petruccio have been entered by Alois Kohn & Co. for \$344.55, and by Henry Tissot for \$246.12.

Henry W. Hart has been appointed assistant appraiser in the jewelry division of the customs service, succeeding Cyrus H. Stevens.

Sellig Bros., 233 and 297 Bowery, have rented the premises owned by Jacob Friedlander, at 264 Bowery, where they will open another store.

Chas. Pierre, of F. & Ch. Pierre & Co., manufacturers of clocks, Paris, France, has returned to Europe. He sailed from New York April 3d, on the *Havel*.

Henry Hershfield, a diamond dealer, at 61 Nassau St., was one of the jurors, who Monday, acquitted Police Captain Devery of the charge of wilful neglect of duty.

The action brought in the City Court by Tiffany & Co. against Edw. C. Wallace has been compromised and settled and an order discontinuing the suit has been entered.

Alexander D. Wilson, 220 W. 34th St., who some years ago was a retail jeweler at 34th St. and Broadway, died, Monday, of heart disease at St. Augustine, Fla. He leaves a widow and four children.

The New York office of Bippart & Co., now at 19 Maiden Lane, will be discontinued May 1st, and the firm will thereafter transact all business from their factory, at Marshall and Halsey Sts., Newark, N. J.

O. L. Sypher, Sr., of Sypher & Co., Max Freund, of Max Freund & Co., and S. Frankel, of Jos. Frankel's Sons, New York, were among the passengers for Europe on the *Teutonic*, Wednesday.

Two judgments for \$1,924 have been obtained in the City Court here against Chas. Bensmann, jeweler, at 777 Fulton St., Brooklyn—one of \$1,189, in favor of Meta Bensmann, and the other for \$735, in favor of H. J. Lankeau.

Justice Tighe, in the Butler St. Police Court, Brooklyn, Monday, held for the Grand Jury, Frank Roberts, of 328 E. 21st St., New York, who was charged by Adolph Schweizer, jeweler, 710 Third Ave., Brooklyn, with stealing a watch from his store on Saturday.

Edward Kopke, aged 69, of 390 Adelphi St., Brooklyn, who is said to be a jeweler, was taken suddenly ill in front of his residence Tuesday evening, April 3d, and was dead when an ambulance surgeon reached him. The body was taken into the house, and the coroner notified.

R., L. & M. Friedlander, jobbers of watches, diamonds, tools, materials and optical goods, 65 Nassau St., will remove May 1st to 30 Maiden Lane, instead of 38 Maiden Lane as first decided upon, as the New Haven Clock Co. have decided to retain the store at the latter address.

Anna M. Cooley, widow of the late Joshua A. Cooley, of the old-time firm of Sillcocks & Cooley, died at her residence, 111 W. 69th St., Tuesday, April 3d. The deceased was 64 years old. The funeral services were held Friday morning, at the Central Presbyterian Church, in W. 57th St.

A cabin passenger from the American liner *Chester*, named E. A. Lacroix, was caught Thursday while trying to smuggle ashore goods valued at about \$250. In the lot were three gold watches and chains, and a silver watch and chain. The goods were taken to the seizure rooms, and Lacroix was allowed to depart.

Judge Cox, in the United States Circuit Court, yesterday heard arguments on the demurrers made by the E. Howard Watch and Clock Co., the Bay State Watch Case Co., and Jas. H. Noyes, to the amended complaint of the Dueber Watch Case Mfg. Co., in the latter's suit against the manufacturers of watches and cases. Decision was reserved.

Jacob Friedlay, a watch case maker and janitor of the buildings at 75 and 77 Nassau St., is in prison in \$10,000 bail awaiting trial at General Sessions upon two serious charges. When arraigned in the Tombs Police Court, March 31st, he was accused of assault upon his 13-year-old daughter, Lulu, and with injuring her morals. He was held in \$5,000 on each charge.

Judge O'Brien, of the Supreme Court, some days ago, denied the motion of S. Firuski & Son for an order directing the receiver of the Canal St. Bank to pay over to the sheriff the amount remaining to the credit of Mendel Newman, to be applied to the judgment for \$3,999.70, confessed by Newman to the plaintiffs last October. In denying the motion the judge orders that the money remaining to Newman's credit be paid over to Jacob Mocher, to whom Newman had assigned his claim against the bank.

On complaint of Louis A. Meyers, jeweler, 695 Fulton St., Brooklyn, Hattie Elmendore, 219 Pearl St., Albany, was a pris-

oner in the Myrtle Avenue Police Court, charged with grand larceny. Jeweler Meyers charged her with stealing a pair of diamond earrings worth \$50 from his store on March 21st. Mrs. Elmendore admitted taking the jewelry, but claimed they were promised her as a present. Justice Haggerty held her to await the action of the Grand Jury. Detectives from Brooklyn went to Albany and returned with the earrings on Friday.

In the Jefferson Market Police Court, Wednesday, Justice McMahon held for examination Elihu R. Campbell, 63 years old, who was accused by Sigmund Kerskovitz, dealer in notions and jewelry, 66 W. 23d St., with stealing a clock worth \$35. When the prisoner was searched after his arrest, he had \$20 cash, five gold watches, a diamond locket, diamond collar button and five unset diamonds. Besides these, he had a tag of a clock marked \$40. This clock was stolen earlier in the day. Campbell is well-known on the east side. Recently he has been speculating in diamonds and jewelry. His friends say that he is insane.

The store of Moses Straus, 409 Fulton St., Brooklyn, was visited by two men last week who purchased a watch and offered in payment a check for \$300 on the National City Bank. Before accepting the check Mr. Straus took it to the bank to see if it was genuine and was about to present it, when he was seized by C. F. Danforth, the drawer of the check who had lost it and gone to stop payment upon it. Mr. Straus explained the matter satisfactorily, and Mr. Danforth called a policeman and went with him to Straus's store. There they found Isaac Pastelurck and Max Sacarni, two Poles, who were at once arrested. The prisoners were held for grand larceny.

The following scores were made at the Jewelers' Individual Bowling Tournament, held Monday evening:

|                |     |                |     |
|----------------|-----|----------------|-----|
| Roll.....      | 156 | Clifford ..... | 102 |
| " .....        | 155 | " .....        | 149 |
| Shiman.....    | 177 | Sacks.....     | 152 |
| " .....        | 192 | " .....        | 167 |
| Woodward.....  | 182 | Thompson.....  | 137 |
| " .....        | 180 | " .....        | 156 |
| Woodland.....  | 162 | Thornbury..... | 156 |
| " .....        | 175 | " .....        | 134 |
| Thompson.....  | 150 | Sacks.....     | 149 |
| " .....        | 170 | " .....        | 136 |
| Thornbury..... | 140 | Clifford ..... | 133 |
| " .....        | 134 | " .....        | 111 |
| Woodland ..... | 184 | Sacks.....     | 174 |
| " .....        | 142 | " .....        | 144 |
| Thompson.....  | 172 | Clifford ..... | 104 |
| " .....        | 159 | " .....        | 140 |
| Roll.....      | 162 | Woodward.....  | 156 |
| " .....        | 215 | " .....        | 143 |
| Shiman .....   | 158 | Clifford.....  | 122 |
| " .....        | 170 | " .....        | 140 |
| Thompson.....  | 181 | Townley.....   | 157 |
| " .....        | 188 | " .....        | 133 |

The silver sleeve buttons are showing in new and pretty forms. A white button diamond crossed in dull silver, with raised and broken edges is one of the prettiest of the new designs.



**Philadelphia.**

J. M. Harper spent several days on business in New York last week.

There was a very successful smoker at the Jewelers' Club on Monday evening last.

J. B. Boden's Frankford Ave. store has undergone extensive repairs and alterations.

Harry Kirk, of Samuel Kirk & Son, Baltimore, spent some time with his Philadelphia friends while on his way to Atlantic City last week.

The testament of Horatio N. Fitzgerald, of the National Optical Co., who died recently, admitted to probate April 4, devises his entire estate, amounting to over \$100,000, to the testator's widow, son and daughter and grandchildren. The executors are John H. Michener, Charles H. Fitzgerald and Harry G. Michener.

Detective Bond returned from Baltimore on Thursday night having in custody John Thomas and John Campbor, whom he had arrested on the charge of robbing the jewelry store of G. W. Davis, 235 S. 12th St., some time ago, when several gold and silver watches were stolen. The men were committed for trial.

The limited partnership existing between Westcott Bailey and E. W. Bailey, special, having expired April 1st by limitation, another co-partnership under the firm name of Westcott Bailey & Co. has been formed for the "importation of and traffic in pre-

ciuous stones, jewelry and works of art," at 1020 Chestnut St.

On Thursday evening thieves entered the store of S. Bernstein, 1214 N. 2d St., and managed to get away with four watches valued at about \$200. The theft was a mysterious one, inasmuch as the loss was not discovered until Mr. Bernstein was closing up for the night, and he had been about the store all evening. The thieves are supposed to have sneaked in between 6 and 8 o'clock. The police were notified.

C. A. Longstreth, on April 2d, bought out Queen & Co.'s downtown store at 228 Market St. He started this store for Queen & Co., in 1885 and has managed it ever since. He will employ the same salesmen and workmen in the factory, as were individually selected by him. The firm devotes itself almost exclusively to the careful testing of the eye and has fitted up a room with special reference to this important work.

Harry Faul, formerly property man at the Temple Theatre, has been arrested and held for court on the charge of larceny. T. L. Bear, a Camden jeweler, the complainant, alleges that Faul borrowed goods from him to be used on the stage and failed to return them. A number of other merchants were fleeced in the same manner. Manager Durban states that the missing goods were procured by Faul without his knowledge, and were never used in the theatre.

The suit of receiver Fisher, of the Spring Garden Bank, against Simons, Bro. & Co.,

to recover on a \$5,000 note, was begun in the United States Circuit Court, before Judge Butler, on Thursday. The case was tried in October, 1892, and resulted at that time in a verdict for \$4,830.50 against the firm. The amount represented the \$5,000 less credit for a balance of deposit, and the interest added to the difference. The verdict was subsequently set aside, and a new trial was granted.

**The Attleboros.**

S. M. Einstein returned Thursday from a western business trip.

Horton, Angell & Co. have been closed a week on account of stocktaking.

W. & S. Blackinton closed their factory last Wednesday and will reopen on the 16th inst.

William A. Bushee, whose death was noticed in THE CIRCULAR last week, was the father of Albert and Charles Bushee.

Frank Carpenter is spending some time in New York, combining business with pleasure. He will return about the 15th.

In payment of an election bet, J. L. Sweet, of R. F. Simmons & Co., banquetted a party of Attleboro business men at the Park Hotel.

At Mansfield business has had a pretty good boom. D. S. Spaulding and Evans, Cobb & Co.'s shops are both running on full time.

**L. TANNENBAUM & CO.,**

**Importers and Cutters of DIAMONDS AND PRECIOUS STONES,**

**COR. MAIDEN LANE & NASSAU ST., NEW YORK.**

Telephone, Long Distance, 1959 Cortlandt.

25 HATTON GARDEN, LONDON.

**IN ORDER TO REDUCE OUR ENORMOUS STOCK WE OFFER THIS WEEK AT SPECIAL PRICES, THE FOLLOWING GOODS:**

Rough Siam Rubies for cutting purposes, at 50c. per karat.

Rough Fancy Sapphires for cutting, at 25c. per karat.

Rough Sapphires for mechanical use, and precious stones for collections, at \$2.50 per ounce.

**SAPPHIRES.**

|        |    |                                    |                 |
|--------|----|------------------------------------|-----------------|
| 19,579 | 1  | Fine Sapphire, 2 28-64 kt.         | \$45.00 per kt. |
| 2.53   | 1  | " 2 42-64 kt., . . .               | 65 00 "         |
| 10,585 | 1  | " 3 less 5-64 kt., . . .           | 60 00 "         |
| 11,487 | 1  | " 4 less 4-64 kt., . . .           | 45 00 "         |
| 18.54  | 1  | " 1 5/8 kt., . . .                 | 45.00 "         |
| 3,456  | 1  | " 7 3-6 kt., . . .                 | 40.00 "         |
| 8,606  | 1  | " 4 44-64 kt., . . .               | 33.00 "         |
| 3,449  | 7  | Carb " 2 25-64 kt., . . .          | 10.00 "         |
| 17,420 | 1  | " 6 50-64 kt., . . .               | 25.00 "         |
| 19,420 | 6  | " 10 3-64 kt., . . .               | 8.00 "          |
| 10,420 | 7  | " 10 1/2 kt., . . .                | 10.00 "         |
| 23,348 | 11 | " 15 18-64 kt., . . .              | 15.00 "         |
| 7,212  |    | Fine Small Sapphire, 45 49-64 kt., | 10.00 "         |
| 3,206  |    | 106 Sapphires, 27 8-64 kt., . . .  | 6.00 "          |
| 4,208  | 57 | " 18 36-64 kt., . . .              | 5.00 "          |

**RUBIES.**

|        |        |                                      |                |
|--------|--------|--------------------------------------|----------------|
| 6,321  | 1      | Carb. Ruby, 6 1/2, 1-32 kt., . . .   | \$4.00 per kt. |
| 1,469  | 1      | " Oriental Ruby, 3 37-64 kt., . . .  | 40.00 "        |
| 1,126  | (Fine) | 1 Carb. Ruby, 1 26-64 kt., . . .     | 100.00 "       |
| 3,393  | 6      | Fine Rubies, 8 1/4, 3-64, kt., . . . | 25.00 "        |
| 31,532 | 12     | " 7 1/8, 1-16, 1-32 kt., . . .       | 28.00 "        |
| 34,333 | 14     | Rubies, 15 3/8, 2-64 kt., . . .      | 15.00 "        |
| 8,187  | 6      | " 9 57-64 kt., . . .                 | 15.00 "        |
| 16,652 | 117    | " 45 1-16 kt., . . .                 | 15.00 "        |

|        |     |                                   |               |
|--------|-----|-----------------------------------|---------------|
| 2,342  | 49  | Rubies, 22 1/8 kt., . . .         | 10.00 per kt. |
| 5,533  | 161 | " 23 60-64 kt., . . .             | 8.00 "        |
| 15,533 | 166 | " 50 less 4-64 kt., . . .         | 8.00 "        |
| 5,541  |     | " 22 42-64 kt., . . .             | 4.00 "        |
| 23,540 |     | " 36 38-64 kt., . . .             | 4.00 "        |
| 4,161  |     | Small Rubies, 46 56-64 kt., . . . | 3.00 "        |
| 2,349  | 48  | Carb. Rubies, 35 30-64 kt., . . . | 1.50 "        |
| 20,317 | 7   | " 7 10-64 kt., . . .              | 28.00 "       |

**SPINELS.**

|        |    |                                   |                 |
|--------|----|-----------------------------------|-----------------|
| 1,241  | 1  | Spinel, 3 50-64 kt., . . .        | \$75.00 per kt. |
| 37,107 | 1  | " 3 less 1-16 kt., . . .          | 40.00 "         |
| 38,107 | 1  | " 6 9-64 kt., . . .               | 40.00 "         |
| 1,376  | 63 | Fine Spinels, 36 16-64 kt., . . . | 40.00 "         |
| 3,376  | 21 | " 15 46-64 kt., . . .             | 25.00 "         |
| 20,390 | 12 | " 9 1/2, 3-64 kt., . . .          | 25.00 "         |

**OPALS.**

|        |    |                                    |                 |
|--------|----|------------------------------------|-----------------|
| 23,555 | 1  | Opal, 5 1-64 kt., long oval, . . . | \$20.00 per kt. |
| 1,555  | 1  | " 5 3/8 kt., . . .                 | 15.00 "         |
| 2.89   | 1  | " 4 13-64 kt., round, . . .        | 12.00 "         |
| 13,462 | 34 | " 26 54-64 kt., " . . .            | 12.00 "         |
| 13,460 | 41 | " 44 9-64 kt., " . . .             | 10.00 "         |

**EMERALDS.**

|        |     |                                 |                 |
|--------|-----|---------------------------------|-----------------|
| 22,363 | 1   | Emerald, 1 1/2 kt., Fine, . . . | \$50.00 per kt. |
| 23,363 | 1   | " 1 50-64 kt., . . .            | 75.00 "         |
| 15,444 | 1   | " 1 1/2 kt., . . .              | 70.00 "         |
| 4,359  | 1   | " 2 1/2, 1-32 kt., . . .        | 60.00 "         |
| 29,357 | 1   | " 1 13-64 kt., . . .            | 55.00 "         |
| 16,356 | 1   | " 4 less 4-64 kt., . . .        | 55.00 "         |
| 1,375  | 280 | " 7 1/2 kt., . . .              | 42.00 "         |
| 8,377  | 36  | " 35 1/2, 1-64 kt., . . .       | 36.00 "         |
| 4,367  | 116 | " 35 1/4, 1-32 kt., . . .       | 30.00 "         |



W. F. Merry and Miss Julia F. Bingham were married Thursday.

E. S. Horton has been elected president of the Attleboro Public Library Association.

J. O. Copeland & Co., who were burned out, have located at the north end of the large main Whiting building.

Geo. H. Adams, 37 years of age, a manufacturing jeweler employed in North Attleboro, is at the Massachusetts General Hospital in a very critical condition, as a result of attempted self-destruction. During a fit of despondency he shot himself in the head four times with a 22-calibre revolver. One bullet entered his right cheek, a second his right eye, and another grazed his temple. His recovery is doubtful.

The Spencer Optical Mfg. Co., 15 Maiden Lane, New York, are sending to the optical jobbing trade a handsome plush tray or pad of samples showing their new and taking line of goods. The card comprises about 20 choice selections from the great assortment manufactured by this company. Jobbers

desiring these pads of samples should send their business cards to this firm.

### Last Week's Arrivals.

**THE CIRCULAR has perfected arrangements for obtaining the names and hotel addresses of all the latest buyers visiting New York, and each day posts in its office, 189 Broadway, a bulletin which every member of the trade is cordially invited to copy.**

The following out-of-town dealers were registered in New York during the past week: H. Oppenheimer, Baltimore, Md., Imperial H.; H. E. Rouse, Baltimore, Md., Grand Union H.; A. Webster, Waltham, Mass., Astor H.; J. E. Hill, Boston, Mass., Cosmopolitan H.; L. S. Lowenthal, Bradford, Pa., Union Square H.; M. Mario, Buffalo, N. Y., Astor H.; P. Desjardins, Montreal, Que., Metropolitan H.; F. F. Bonnet, Columbus, O., Imperial H.; C. C. Riggs, Philadelphia, Pa., St. Denis H.; L. Kingsbacher, Pittsburgh, Pa., Imperial H.;

M. M. Birks, Montreal, Que., St. Denis H.; J. Karr, Washington, D. C., Gilsey H.; A. Parker, Boston, Mass., Ashland H.; F. R. Grimes, Chicago, Ill., Continental H.; J. Conigsky, Peoria, Ill., Broadway Central H.; M. Mario, Buffalo, N. Y., Astor H.; L. Emery, Jr., Bradford, Pa., Astor H.; T. M. Knight, Philadelphia, Pa., St. Stephen H.; C. O. Daller, Cincinnati, O., Astor H.

### The Jewelers' Relief Association's Good Work.

The Jewelers' Relief Association of New York, are now in their new headquarters at 12 Maiden Lane. Through the generosity of President Lissauer the association have been supplied with offices on the second floor of the building at that address, rent free.

Arrangements having been made with the East Side Relief Association, many applicants have been given an opportunity to earn a few dollars weekly by working on east side tenements. The work has been paid for by the Jewelers' Relief Association. The fund now amounts to \$7,255, and is still growing.

# "The Jeweler's Circular"

IS FIRST IN THE FIELD IN EVERY SENSE.

**B**ECAUSE

Of its Record for 25 Years.

The Amount and Quality of its News Matter.

Excellent and Superior General Trade Information.

Artistic and Instructive Illustrations.

Scientific and Technical Special Articles.

With these facts before you, should there be any question as to the advisability of sending \$2.00 for "The Jeweler's Circular" for a year?

Begin the New Year properly. With 1894 "The Jeweler's Circular" will begin its TWENTY-FIFTH YEAR, and to thoroughly

impress that fact upon NEW SUBSCRIBERS we offer FREE, with each new subscription, a copy

of any of the valuable books described below:

**Spectacles and Eyeglasses, their Forms, Mountings and Proper Adjustment**, by R. J. PHILLIPS, M.D. A thoroughly practical book on the subject of prescribing spectacle frames. It is intended to give the student that knowledge of the correct placing of the glasses before the eyes without, which the most painstaking measurement will frequently fail of practical result.

**A Handbook of Precious Stones**. By M. D. ROTHCHILD. Cloth Illustrated.

**A Practical Treatise on Electro-Plating**. By EDWARD TREVERT. Just the book for amateurs. Fully Illustrated. Cloth.

**Manual of the Transit Instrument**, as used for Obtaining Correct time. By LATIMER CLARK, M.I.C.E.

**Turning Lathes**. A Manual for Technical Schools and Apprentices. A Guide to Turning, Screw Cutting, Metal Spinning, etc. 194 Illustrations. Edited by JAMES LUKIN, B.A.

**The Watch Jobber's Handy Book**. A practical Manual on Cleaning, Repairing and Adjusting Watches;

with information on the Tools, Materials, Appliances and Processes employed in Watchwork. By PAUL N. HASLUCK. 100 Illustrations.

**The Clock Jobber's Handy Book**. A Practical Manual on Cleaning, Repairing and Adjusting Clocks; with information on the Tools, Materials, Appliances, and processes used in Clockwork. By PAUL N. HASLUCK. 100 Illustrations.

**Goldsmith's Handbook**, containing full instructions for the Alloying and Working of Gold. By GEO. E. GEE.

**Silversmith's Handbook**, containing full instructions for the Alloying and Working of Silver. By GEO. E. GEE.

**Kemlo's Watch Repairer's Handbook**. Illustrated. For beginners and advanced workmen. By F. KEMLO.

**Legends of Gems**. Gilt edged; bound in leather; a perfect specimen of the printer's and binder's art. Should be in every jeweler's library. By FRANK SHELLY.



**Kent & Stanley Co.'s New Building.**

PROVIDENCE, R. I., April 6.—It would seem as though fire, which is usually dreaded by the average business concern had proved a valued co-operator in the plans of the Kent & Stanley Co. for their most extensive building operations have been attendant upon destructive conflagrations. When the famous Aldrich House and adjacent property was destroyed in February, 1888, this enterprising firm purchased a large portion of the burnt district, and phoenix-like from the ashes rose the

St. grade. The entire floor space in the structure will contain about 32,000 square feet and will be divided into shops of varied dimensions according to the requirements of the respective tenants.

The building will be of Berwin brick of the finest quality, the facades being plain and substantial. Those on Beverly and Sabin Sts. are relieved by brown stone arched caps with a keystone center over each window; while all the windows on the remaining facades have brick caps. The large windows have weighted sash and ven-

most interesting feature, however, will be the power plant; the long lines of shafting bolted to the ceilings will be absent. Each tenant will have an electric motor of the proper size for driving his machinery. The current will be generated in the building. The steam plant will consist of water tube boilers of 400 horse power and a 250 horse power engine, probably from the works of the William A. Harris Steam Engine Co., of this city. About 200 incandescent lamps will also be included in the electrical equipment. Exhaust steam will be utilized for heating and provision will be made for supplying live steam in zero weather, if the exhaust should be insufficient. The plumbing and drainage will conform to the rules of the city plumbing and sewerage departments, and the best apparatus for extinguishing fire will be provided in accordance with local fire laws and the rules of the New England Insurance Exchange.

The seventh floor will be occupied by the Kent & Stanley Co.

**Providence.**

Arthur E. Austin has the sympathy of a large circle of acquaintances in the death of his wife, on Monday last.

Battle-axes are pushing the favorite swords as articles of personal adornment. Several concerns in this city have introduced new and handsome lines of these novelties.

George Huling, an employe of the Gorham Mfg. Co., was arrested last week on a charge of stealing silver novelties, which, however, were recovered. He admitted his guilt and was held to await the action of the grand jury.

Information has been received in this city that S. & D. D. Gutman, Rochester, N. Y., are asking for an extension on a basis of 10 cents in July, 20 in August, 20 in September, 25 in January, 1895, and 25 in April, 1895. Providence manufacturers are interested for a considerable amount.

At the election in this State, last Wednesday, when the Republicans made a general sweep of everything, the following jewelers were elected to the General Assembly: Sylvester K. Merrill, as Senator from Cranston, and John L. Remlinger and Henry G. Thresher, as Representatives from Providence and Lincoln respectively.

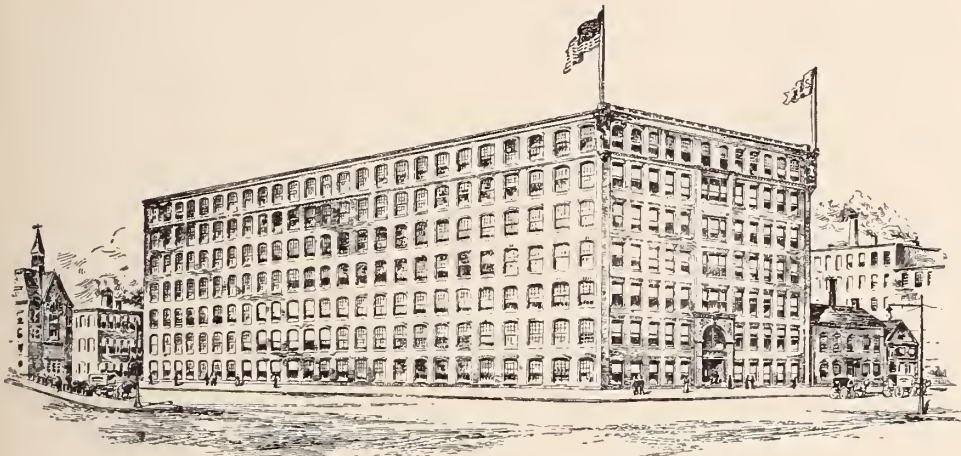

THE NEW FACTORY BUILDING OF KENT & STANLEY CO. BEING ERRECTED.

handsome business block at present partially occupied by the company's factory. Last Fall fire again visited this section of the city, and left in a mass of charred and blackened ruins, the buildings which had occupied the square bounded by Sabin, Aborn, Mason and Beverly Sts. Kent & Stanley Co. at once opened negotiations for this land and their efforts being crowned with success, the erection of a large manufacturing block was commenced. About 300 men are now employed by the contractors, and bricks are being laid at the rate of 80,000 per day. The work is sufficiently advanced to show that the owners will have one of the most creditable industrial plants in New England, and it is apparent to the observer that in materials and workmanship the best has been secured. The building will be completed about the middle of July, and already considerable of the space has been spoken for by manufacturing jewelers, about two-thirds of the seven acres of floor space having been contracted for.

The building is to be one of the largest for manufacturing jewelry purposes in this vicinity, being seven stories high and having a frontage on Mason St., of 275 feet 4 inches; on Aborn St., of 221 feet; on Beverly St., of 123 feet and on Sabin St., of 106 feet 8 inches. The two last facades form the main and office entrances to the several shops, which being uniformly lighted from the light shafts towards the center, a dark apartment on any of the seven floors will be hard to find. From floor to floor the height is 13 feet 6 inches and the total height of the seven stories is 100 feet above the Beverly

tilating transoms, and those on the Beverly and Sabin Sts., are to have plate glass. The wood work of the principal entrance will be of selected quartered oak. The foundations are from 9 to 14 feet below grade line. The footing stones are 7 feet across, and the weight of each varies from five to eight tons. To the level of the third floor the walls are 33 inches thick and laid in cement; from the third to the sixth story the thickness of the wall is 25 inches; 21 inches from the sixth to the top of the seventh floor and 17 inches from the latter to the roof.

There will be high speed passenger elevators of the plunger style, and the central driveway which extends like a tunnel through the building from Sabin to Mason St., will have combination freight and passenger elevators of the same description. These elevators will all be operated by the closed or pressure tank system. The

*We Know* THAT WE CAN GIVE YOU BETTER RETURNS ON YOUR OLD GOLD AND SILVER OR WASTE THAN ANY ONE ELSE. TO PROVE THIS STATEMENT GIVE US ONE TRIAL.



**GEO. M. BAKER,**  
GOLD AND SILVER REFINER AND SWEEP SMELTER. PROVIDENCE, R. I.





THE STAR OF EMPIRE WESTWARD TAKES ITS WAY

# WESTERN SUPPLEMENT

## of THE JEWELERS' CIRCULAR

Chicago Office: Room 517, Inter-Ocean Building.

VOL. XXVIII.

CHICAGO, WEDNESDAY, APRIL 11, 1894.

No. 10.

### Chicago Notes.

George Feagans, Joliet, Ill., is on a southern pleasure trip.

F. F. Strayer, for a number of years traveler for G. W. Marquardt & Sons, was a visitor here Wednesday.

P. H. Bettman, manufacturers' agent in Athenæum building, Adams St., will remove May 1st to the 8th floor Masonic Temple.

George Dilger will open a store the present week on Milwaukee Ave, near Western. Mr. Dilger is a new comer to the jewelry trade.

J. J. Faber, Peoria, Ill., has moved from the Square into a new store on Main St., and will enlarge his stock and cater to the bet'er trade.

Mr. Lazarus, a West Side manufacturer, will occupy room 411 Masonic Temple, as soon as quarters are ready, probably the present week.

Manager Talcott, of the Dennison Mfg. Co., left for the east Saturday en route for a European trip. Mr. Talcott will return early in June.

Manager Todd, of the Towle Mfg. Co., thus tersely sums up the silver business: "The trade is better lately, and collections are not bad—in fact, are rather good."

Carl Gustafson, Petersburg, Ill., has removed to a new location, and now occupies the finest store in that thriving town. Mr. Gustafson has opened up a larger stock than ever before.

It required 218 yards of finest Brussels to recarpet the salesrooms of the Towle Mfg. Co., completed Thursday. The room is recognized as the handsomest silverware salesroom in Chicago.

H. E. King, representing Holmes & Edwards Silver Co. and Manhattan Silver Plate Co., has returned from a thorough canvas of Illinois, and says there is good picking, some districts being in good shape, with others not so good.

J. T. Wells returned Saturday from a Wisconsin trip for Holmes & Edwards Silver Co. and Manhattan Silver Plate Co. Mr.

Wells was in time for the weekly hop at the Hotel Barry, where he was the guest of Mr. King, with the same firms.

The tool and material department of Benj. Allen & Co. has been rushed with orders the past two weeks, due in part, to the fine catalogue of these lines just issued by the firm. Manager Hart, of this department, reports trade most satisfactory, with orders calling for larger amounts of goods.

E. H. Carpenter, Burlington, Ia., the oldest jeweler in the State, will shortly be missing from his accustomed haunts, in his annual search for ducks and muskallonge. Mr. Carpenter is a member of the local sportsman's club, and an enthusiastic devotee of the rod and gun.

A number of members of the March class of the Chicago Ophthalmic College were purchasers of stock from jobbers previous to leaving for home on the completion of the optical course. Prominently mentioned were R. G. Wells, Wellsville, N. Y.; H. B. Shellito, Sault de Ste. Marie, Mich., and H. E. Boughton, Brooklyn, Ia.

"Jewelers' Row," 4th floor Masonic Temple, is rapidly filling up. Katlinsky & Gatzert in 407 and S. Buchsbaum in 409 have previously been mentioned; Metzenberg & Co. moved into 408 early the past week; Lazarus, as elsewhere stated, takes 411 and A. Hirsch & Co. and W. S. & J. B. Wilkin-son will shortly occupy their quarters at the south end of the "Row."

S. N. Clarkson, 182 State St., is chairman of the executive committee and member of the reception committee for the annual ball of Lakeside Lodge, Knights of Pythias, to be held April 19. Mr. Clarkson will remove his business May 1 to larger quarters on the ninth floor of the Champlain building. A part of the new location will be sub-leased to an agent for eastern manufacturers on favorable terms.

Max F. Oberndorf, formerly superintendent of the Chicago Fringe Works, April 1 purchased a half interest in the jewelry manufacturing business of Chas. H. Pfeil, 182 State St., and the firm name now reads:

Pfeil & Oberndorf. Mr. Oberndorf will attend to the secretary's duties of the firm, Mr. Pfeil looking after the manufacturing department. The partnership is the result of a close acquaintanceship between the gentlemen for many years. Diamond work will continue to be a specialty of the factory.

The east, west and Chicago were represented, Thursday, in the Seth Thomas Clock Co's salesrooms in the persons of Mr. Adler, Mr. Miller and Manager Church. Mr. Adler, discussing the west, reports extreme quiet in the far west, flat in Kansas, fair in Missouri, quite respectable in southern Illinois, but as Chicago is approached the condition is less bright, dealers claiming the World's Fair to have drained the country. Mr. Miller, speaking of jobbing points in the east, says business has been very satisfactory, and Manager Church notes a general improvement in the west taken as a whole.

In view of the vacating on March 1st by the Chicago Jewelers' Association of their reception room, an auction sale of furniture was held Wednesday at the rooms, at the close of the regular monthly meeting. A. Hirsch volunteered as auctioneer. "How much am I offered—" he commenced, when a heavy hand was laid on his shoulder and Mr. Hirsch turned, to be confronted by the largest policeman on the Chicago force. "Show me your license!" gruffly demanded the officer. "I'm only selling for that man there," replied Mr. Hirsch, pointing to vice-president Grove Sackett. Mr. Sackett denied the impeachment and the officer again demanded to be shown the auctioneer's license. Mr. Hirsch protested it was only a private affair. Then when the officer's sternness softened into a broad smile what a shout went up! The auctioneer had been made the victim of a practical joke by some member, who had quietly slipped out and given the tip to the police. Good prices were realized at the sale, the largest purchaser being Mr. Thurber, owner of the Columbus building, who will use the furniture in his private library.



Among the prominent jewelers purchasing goods in this city last week were noted: Mr. Kiep, Zahn & Kiep, Joliet, Ill.; Geo. H. Thoma, Three Rivers, Mich.; Jas. R. Toogood, Manchester, Ia.; F. C. Crook, Janesville, Wis.; E. J. Peck, Braidwood, Ill.; Mr. Barger, Woodstock, Barger & Hoefer, Kansas City, Mo.; H. B. Shellito, Sault de Ste. Marie, Mich.; H. E. Boughton, Brooklyn, Ia.; J. C. Peers and wife, Rockford, Ill.; R. G. Wells, Wellsville, N. Y.

**Changes in the Business of Moore & Evans.**

CHICAGO, Ill., April 9.—Geo. B. Moore, of Moore & Evans, wholesale jewelers, Masonic Temple, April 2 bought the interests in the company represented by A. T. Evans and will continue the business on its present lines. The company was some time since incorporated under the State laws with a capital stock of \$60,000, of which Mr. Moore owned a majority of the shares. The transfer of stock by the recent purchase makes him practically the sole owner of the corporation.

Mr Evans has been granted a license by the Secretary of State to incorporate as A. T. Evans & Co., with a capital stock of \$10,000, and will shortly open up a business under the old firm name. The details of the new corporation have not been fixed upon, but it is expected the business will be conducted on similar lines to those followed by Mr. Evans in his former business connections. The purchase of the stock of Moore & Evans by Mr. Moore was an amicable one, he desiring to secure all the benefits accruing from a prosperous business.

The improvements which have been in progress for the past month at G. A. Schlechter's jewelry store, 6th and Penn Sts., Reading, Pa., are almost completed and when finished it will be one of the finest jewelry stores in the city. An entire new front was put in, on each side of which are two large show windows, which will enable Mr. Schlechter to show his goods to advantage.

**The Stock and Fixtures of F. G. Smith, Sons & Co. Sold.**

DETROIT, Mich., April 7.—The stock and fixtures of F. G. Smith, Sons & Co., 163 Woodward Ave., were sold this morning by Commissioner Greenstine to F. G. Smith & Sons for \$45,625. They were sold to them as individuals, not as a corporation. The bidding was lively, and it was thought at one time that the eastern creditors had formed a pool to buy in the stock. The book accounts will be sold on April 17.

Out of 185 creditors the following were represented: Henry Veith, Oppenheimer Bros. & Veith; David Kaiser, Lewis, Kaiser & Luthy; Mr. Matcheske, Kuhn, Doerflinger & Co., and Charles F. Ketcham, Riker Bros. The following local jewelers were interested spectators: R. J. F. Roehm, Edward Roehm, Henry Koester, Herman Yohn, with Eugene Deimel, and George L. Lowe.

After paying \$38,400 to trustee Howard for local creditors, there will be about \$7,225 left for assignee Boynton to divide among the eastern creditors. The firm owes them \$74,500. This will amount to about 10 cents on the dollar.

F. G. Smith, Sr. was seen by a represen-

tative of THE CIRCULAR, but he was too excited to say much. "I haven't time to talk," said he, "as I must go right out and obtain the cash to pay for this stock. We have a lease on our present quarters until next February, and will continue the business until then here. After that some other location will have to be looked up as C. H. Michell, the grocer, has a 15 year lease on the property."

**An Execution Against the H. M. Betz Watch & Jewelry Co.**

PHILADELPHIA, Pa., April 5.—Execution was issued yesterday from the Common Pleas Court by Andreas Endrich and Frederick W. Betz, against the H. M. Betz Watch & Jewelry Co., of Philadelphia, on judgment on a note for \$8,002.80, dated March 17th and payable in one day.

It is explained by counsel for the company that its troubles have been brought about by the general business stagnation, and the inability to collect outstanding debts. The notes were given in exchange for money advanced. The company's offices are at 631 Chestnut St., and the company was chartered under the laws of Kentucky. It did an instalment business and has a host of debtors.

**OPTICAL DEPARTMENTS ESTABLISHED.**



AN EXPERT OPTICIAN will thoroughly establish an Optical Department in a limited number of FIRST CLASS JEWELRY STORES, giving his own time as promoter until on a successful basis. Will also give complete instructions in fitting to the man designed as head of the department.

**THERE'S MONEY IN IT.**

Jewelers wishing to make a special run in their optical department or establish one, will find this a rare opportunity. Your business can be increased \$1,000 to \$2,000 a month. Arrangements can be made either on percentage or salary. An unusual opportunity for a good house to

**ENTER A LUCRATIVE FIELD.**

ADDRESS

**OPTICIAN, Care JEWELERS' CIRCULAR, Chicago Office,**

**308 INTER-OCEAN BUILDING, CHICAGO.**

**JUST OUT!**

**Our New Illustrated Catalogue of . . . .**

**Watch Materials, Tools, & Jewelers' Supplies was issued MARCH 20th.**

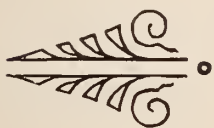

IF you have not already received a copy notify us and we will send you one at once. We wish to emphasize that our Prices will be found the LOWEST, quality of goods considered. With a well selected stock we are enabled to fill all orders promptly and correctly.

**BENJ. ALLEN & CO.,**

141-143 STATE STREET, . . . CHICAGO, ILL.

**Watches, Diamonds, Clocks and Jewelry.**



**Indianapolis.**

E. C. Miller writes from Hot Springs, Ark., that he has found much relief from rheumatism.

D. J. Reagan, western traveler for Baldwin, Miller & Co., returned April 1st from a prolonged trip. He reports trade growing better.

L. L. Norton has removed his stock of tools and materials from W. Maryland St. to the Hubbard Block, corner Meridian and Washington Sts.

The Vienna Optical Institute has located at 65 E. Ohio St. Wm. Steinke, optician and proprietor, has studied both in Vienna and New York.

The jobbers say that trade continues to improve gradually. Just at present there is a great demand for hairpins. The better class goods sell well, while the demand for the cheaper grades continues to grow.

April 3d Anna J. Comstock was granted a divorce from her husband, Horace A. Comstock, the Washington St. jeweler. All

property questions were settled by mutual consent outside of court.

Traveling men in Indianapolis last week were: Herbert W. Van Houten, Sinnock & Sherrill; M. Stein, Wendell Mfg. Co.; G. Rodenberg, S. & B. Lederer; C. W. Battey, Waite, Mathewson & Co.; Tom Davis, Middletown Plate Co.; L. E. Smith, M. B. Bryant & Co.; Mr. Bliss, Gorham Mfg. Co.; Mr. Allerdice, Ed. Todd & Co.; F. L. Pettee, Waterbury Clock Co.; and Max M. Kolliner.

**Pacific Coast Notes.**

Geo. A. Allen has opened a new jewelry store at 1032 I St., Fresno, Cal.

H. Morton is having an auction sale at his store, 36 S. 1st St., San José, Cal. The sale will last 10 days. He is not closing out.

Edward Reagan, Carson, Nev., has invented a mercurial alarm clock to be used in maintaining a fixed temperature in any room.

A. W. Anderson & Bro., Martinez, Cal., have purchased the establishment of J. F.

Holland, of the same place, and will hereafter conduct the business. Both brothers are practical watchmakers and engravers.

The Sunset Jewelry Co., Los Angeles, Cal., are closing out their stock at auction. This constitutes two jewelry stores that are conducting auction sales in Los Angeles at the present time, the other being M. German who is running a daily sale some doors above on the same street.

**San Francisco.**

A. Goldman, Bakersfield, Cal., was in San Francisco a few days ago.

W. E. Steben, Visalia, Cal., is in town visiting the Fair and purchasing goods.

Joe Rittler who has been in the employ of M. L. Levy & Co. for a number of years, has severed his connections with that firm.

W. D. Haynes, Travers, Cal., has given up business in that place and has opened a repair shop with his brother at 1430 Howard St., this city. He has the sole right to sell the Columbus wooden clocks at the Mid-Winter Fair.

**We are proud of our CHUCKS**

THEY HAVE NO EQUAL AT ANY PRICE.

ALL KINDS, \$1.00.



MADE ONLY BY **HARDINGE BROS.,**  
1036 Lincoln Ave., CHICAGO, ILL.

**REED & BARTON,**  
**SILVERSMITHS,**  
MANUFACTURERS OF  
**STERLING and SILVER PLATED**  
**SILVER WARE.**

SALESROOMS:  
**37 Union Square, New York.**  
34-36 WASHINGTON STREET,  
**Venetian Building, Chicago.**  
FACTORIES, TAUNTON, MASS.

**R. M. JOHNSON,**  
IMPORTER OF  
**Diamonds and Manufacturing Jeweler,**  
67 WASHINGTON STREET,  
ROOMS 5 & 6,  
CHICAGO.  
MASONIC EMBLEMS OF EVERY DESCRIPTION MADE TO ORDER.

**DUEBER-HAMPDEN WATCHES.**  
The most reliable watches are the Hampden 17 Jewel. A full line of Dueber Cases and Hampden Movements. Cash buyers write us.  
**BRETHAUER WATCH & JEWELRY COMPANY,**  
SPECIAL AGENTS,  
71 WASHINGTON ST., CHICAGO, ILLS.

**THE PLANCHAMP & BECKER CO.**  
Makers and Repairers of  
**WATCH CASES,**  
Gold and Silver Plating —  
— of Watch Cases a Specialty.  
UNEXCELLED FACILITIES.  
53 and 65 East Washington St., Chicago.

WHEN IN CHICAGO, VISIT THE  
**Chicago Watchmakers' Institute,**  
SUITE, 1521-1523 B MASONIC TEMPLE.  
A Modern Trade School for the Watchmaker, Jeweler and Engraver. Write for New Catalogue.





F. Kocher, R. Kocher & Son, San José, Cal., was in town for a few days.

H. Rosencrantz & Co., 124 Pine St., will move into larger quarters at 213 Bush St.

E. J. Stelzer, Crescent City, Cal., was in town a few days ago on his way to Cairo, Ill.

August Golby, 117 Sutter St., has discontinued business and taken a position with Shreve & Co.

H. M. Cutter, of the Elgin National Watch Co., has been in town visiting the trade and the Mid-Winter Fair.

F. Golden, Carson, Nev., and Nevada City, Cal., has been here purchasing goods and visiting the Fair.

Mrs. L. A. Jewett, formerly in the jewelry business in this city, was married recently F. M. Bishop.

O. W. Bullock, of O. W. Bullock & Co., Springfield, Mass., was here recently, visiting the watch tool and supply houses.

J. Ridley, 510 Valencia St., intends to sell out as he is going to England to settle an estate that has been left him by an uncle.

E. J. Barrett, formerly with Cook & Lee, Prescott, Ariz., has gone to work for W. Manning, in the Phealand building, this city.

M. Wetzold has opened a store in Wil-lows, Cal. He was here a few days ago buying goods and fixtures. W. H. Morgan, of Fort Ross, was also here buying goods.

Fred Roth, M. & L. Kahn & Co., New York, has been in town showing some very fine gems. S. Englander, New York, and W. Melcher, Bennett, Melcher & Co., Providence, R. I., were also here.

**Cincinnati.**

Order and repair work keep Jonas, Dorst & Co. fairly busy.

Chas. Ankeny, of Duhme & Co., has been in Chicago on a business trip.

A. Herman, of D. Schroder & Co., is on the road, sending in fair orders.

Homan & Co. are still bringing out new goods. Their sales are principally in their new lines, staple lines being very slow.

The Ansonia Clock Co. have brought suit vs. Leopold Strauss and Charles J. Stern, to recover \$4,136.48, due on account of goods delivered.

The Duhme Co. have re-organized. Charles Duhme has re-entered the firm and has been elected president; he had withdrawn from the firm a few years ago. R. H. Galbreath is vice-president, and Louis Duhme, sec-

**Jewelers' Auctioneer.**



**NEVER A FAILURE.**

References from over 300 Wholesale and Retail Jewelers in all parts of the country. Profits Guaranteed. Correspondence Confidential. Write for terms and details.

**501 MASONIC TEMPLE,  
CHICAGO.**

retary. The new board of directors, it is expected, will be a strong one.

There is a most interesting collection of Icelandic art work in silver on exhibition at the Art Museum, loaned by Madame Magnusson, formerly of Reykjavik, Iceland, but now of Cambridge, England. Among the ornaments are belts, buckles, silver crowns and brooches, all the work of native silver-smiths.

Jos. Noterman bought, last week, a 9½ grain pearl, of perfect color and form, from a farmer who found it on Licking River bank, a few miles from Cincinnati. The same man also found a pearl hand, perfect in shape, less than an inch in length. He has been offered a large sum for it, but will not part with it.

**PFEIL & OBERNDORF,  
MANUFACTURING JEWELER.**

**Diamond Work a Specialty.**

- BEST of Workmen.**
- BEST Design Work.**
- GUARANTEED Workmanship**

Send a trial order and be convinced.

**182 State St., Chicago.**

**HUGO MUELLER,  
182 State St., (Room 70,) Chicago.**

**FINE WATCH REPAIRING**

IN ALL ITS BRANCHES.

Work for the trade promptly executed by skilled workmen.

**PARSONS : SCHOOL**

— FOR —

**WATCHMAKERS,**

**PEORIA, - - - ILL.**

Send for Circular and Terms.

**PARSONS & CO.**

**The Wadsworth Watch Case Co.**



**Filled**



**Cases.**



**General Offices,  
NEWPORT. KY.**

**Chicago Office,  
COLUMBUS BUILDING.**



# PATENT FIBRE-FACED HAMMERS.

5 oz. for Watchmakers.  
10 oz. for Manufacturing Jewelers  
Price 50 Cents Each.

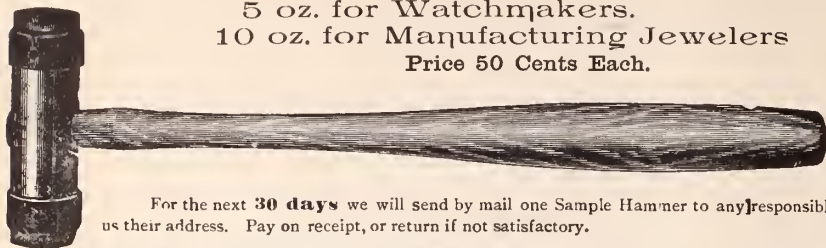

For the next **30 days** we will send by mail one Sample Hammer to any responsible firm giving us their address. Pay on receipt, or return if not satisfactory.

**W. W. OLIVER, Sole Manufacturer, - Buffalo, N. Y.**

Send for our No. 10 Catalogue.

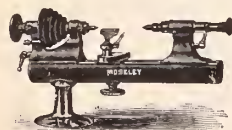

One of the best of the very best.

**QUALITY IS THE STANDARD OF VALUE.**

**CHARGES TO SUIT THE TIMES.**

When interested, write your jobber for new price list for 1894, or

**Moseley & Co., Elgin, Ill.**



No. 2 Moseley Wire Chuck has length, strength, accuracy.



## GIBSON HOUSE,

CINCINNATI, OHIO.

ABSOLUTELY FIRST-CLASS AMERICAN PLAN HOTEL.

\$3.00 PER DAY.

Extra Charge for Parlors and Rooms with Bath attached. The unequalled advantages in central location, liberal management, modern appointments, experienced service and perfect cuisine, have permanently established the Gibson House as The Most Popular First-Class Hotel in Cincinnati,

AMPLE VAULTS FOR THE PROTECTION OF VALUABLES.

**THE GIBSON HOUSE CO.,**

H. B. DUNBAR

President and Manager

... THE ...

# American Horological Institute

AND TECHNICAL SCHOOL OF LANCASTER, PA.,  
LATE OF PHILADELPHIA, PA.,

A Trade School where Watchmaking is taught practically. We do not manufacture

☼ BICYCLES OR DYNAMOS ☼

at this institute. We confine our work strictly to **WATCH WORK** and its kindred branches, which include

≈ Engraving, Jewelry Work and Optics ≈

One tuition pays for all the branches. We do not have boy instructors at this institute, all men of years of experience. Each department has its separate instructor. Our institute is open for inspection. We kindly invite you to visit us and inspect our school modes of giving instruction and the progress that our students make by giving them practical instruction.

**THOMAS PENDERGAST,**

PROPRIETOR AND MANAGER.

## Minneapolis and St. Paul.

Alfred Nathan, representing Max Nathan, called on the jobbers of the Twin Cities the past week.

B. Bank, Minneapolis, last week removed from 127 Nicollet Ave. to a more central location at 232 First Ave. S.

A. J. Pollock, St. Paul, has removed from 391 Robert St., to Room 202, Endicott building, corner 4th and Robert Sts.

T. R. Wall, representing the Geneva Optical Co. and the Waterbury Clock Co., Chicago, called on the trade here the past week.

Jesse Collom, Minneapolis, made an assignment on March 31st, to G. E. Tuttle. The deed and affidavit filed give the valuation of Mr. Collom's property at \$1,500; liabilities not given. The assignee is advertising the stock and business for sale.

Out-of-town jewelers visiting the Twin Cities the past week were: A. E. Mealey, Delano, Minn.; A. Hammarsten, Co ato, Minn.; August Swedlund, Atwater, Minn.; E. C. Bennett, Red Wing, Minn.; A. Pearlman, Washburn, Wis.; Lucien Diacon, Chaska, Minn.

A. Hammarsten, Cokato, Minn., who was a partner in the firm of P. Hamberg & Co., whose store was recently burned out, has withdrawn from the firm and started in the jewelry business on his own account. P. Hamberg will reopen in business again for himself.

The I. B. Miller Jewelry Mfg. Co. have removed from Chicago to Minneapolis and are now located at 26 Washington Ave. S., having purchased the fixtures of and rented the store formerly occupied by A. Sanborn & Co., jewelers. The firm will conduct both a wholesale and retail business.

Misses M. & E. Healey, 1122 Connecticut Ave., Washington, have evolved a method of gilding china that surpasses in beauty of effect the finest productions in gilded china either of the Sèvres or Dresden manufactories. The lustre is soft and velvety, after the character of the old Etruscan gold work, and many of the pieces of these *chryso ceramics* are as beautiful as Etruscan jewelry. The secret belongs exclusively to these ladies, and their case of china in the Woman's Building at the World's Fair, at which they received two first prizes for their work, was a center of attraction for thousands interested in fine ceramics. Specimens of this china are being eagerly collected for cabinets and for dainty table use. The decoration has the merit of durability, requiring only a little ammonia in the water for washing and polishing with chamois skin.—*Decorator and Furnisher.*



The Roy Watch Case Co. Cases are Sold only through Jobbers.





**Cleveland.**

H. F. Weaver, of F. H. Weaver & Son, has established a new jewelry store at 574 Pearl St.

Representatives of the Holmes & Edwards Silver Co., and E. L. Logee & Co., were in Cleveland last week.

The Cowell & Hubbard Co. will occupy store rooms in the new Garfield block, on Euclid Ave., when it is completed.

C. G. Deuble was in town last week buying supplies for the new firm of C. G. Deuble & Brother, 30 North Market St., Canton, O.

Chas. G. Deuble, a jeweler of Malvern, O., has moved to Canton. It is said that Fred Schreiber will start a repair shop in the former place.

C. E. Hunter, a jeweler of Bowling Green, O., set a hen in his store window and offered a prize to the girl under 12 years of age who should guess nearest to the number of chicks hatched.

Both Jos. and Louis Goldsoll are still fugitives from the city, and are very much wanted by their creditors. The latest movement made against the firm was inaugurated last week, when warrants for the arrest of the Goldsolls were sworn out by H. L. Josephs, acting as agent for O. M. Draper, Attleboro, Mass. The warrants allege that the Goldsolls, trading as L. H. Goldsoll & Bro., secured goods valued at \$5,600

from Draper through Josephs, on claims that they had assets of \$24,000 and liabilities of only \$11,000, which claims Josephs alleges to be false. The warrants were issued by Justice Poe, and placed in the hands of Detective Mintz to serve. Mintz is looking for the Goldsolls.

**Kansas City.**

Mr. Willett, of Willett & Rankin, Olathe, Kan., was here a few days ago buying goods.

Flint Bowen is traveling in Colorado this week. He spent several days recently in Leadville.

Benjamin Levin has opened a wholesale jewelry establishment in rooms on the ground floor of the Baird building, corner of 6th and Wyandotte Sts.

J. R. Gleason has moved his jewelry store from 1007 Walnut St. to 1006 Main St. The new store is in a more prominent location and is much larger and lighter than the old one.

Joe Bernstein, the traveling salesman for M. C. Eppenstein & Co., Chicago, has returned to the World's Fair City with one of the partners of the concern. He will not be prosecuted for pawning his samples in this city.

George H. Edwards, of the Edwards & Sloane Jewelry Co., and M. L. Barger, of Woodstock, Barger & Hoefer, attended the organization of the jewelers' association at

Des Moines, Ia., last week. Mr. Edwards visited St. Joseph and other northern points before returning home.

**Major Leslie, of Leadville, Finds a Bomb at His Door.**

LEADVILLE, Col., April 4.—Major Gavin Leslie, a prominent jeweler of this city, and sheriff of Lake County, found an unexploded bomb near the door of his office in the Court House this morning. It was made of two-inch wrought iron pipe, capped at each end, and having a fuse running through a brass tube to the powder within. The fuse had been ignited but had failed to burn.

Yesterday was election day, and ill feeling from that source is thought to have been responsible for the attempt to blow up Mr. Leslie's office.

**BOLSTAD MFG. AND PLATING CO.,**

(H. E. BOLSTAD, PRES.)

WATCH CASE MAKERS, REPAIRERS. PLATERS.  
PLATED INLAYING ON CASES.

BEST WORK. BEST WORKMEN.

170 MADISON ST., - CHICAGO.

**ELGIN HOROLOGICAL SCHOOL,**THOROUGHLY PRACTICAL.  
COMPETENT INSTRUCTORS.

Send for Prospectus.

ELGIN, ILL.

# THE JEWELERS' CIRCULAR

IS FIRST IN THE FIELD IN EVERY SENSE.

SEND US \$2.50 AND GET "THE CIRCULAR" FOR ONE YEAR AND A COPY OF

## "WORKSHOP NOTES"

For Jewelers and Watchmakers."

BEING A COLLECTION OF THE LATEST PRACTICAL RECEIPTS ON THE MANUFACTURE AND REPAIRING OF WATCHES AND CLOCKS, AND ON THE VARIOUS PROCESSES ENTERING INTO THE MANUFACTURE AND REPAIRING OF JEWELRY, AS COLORING, POLISHING, ENAMELING, ANNEALING, OXIDIZING, ETC. IN SHORT A THOROUGH COMPENDIUM OF THE NUMEROUS MECHANICAL DEPARTMENTS OF THE JEWELERS' AND WATCHMAKERS' SHOP.

200 PAGES, BOUND IN CLOTH, STIFF COVERS.

THE JEWELERS' CIRCULAR PUBLISHING CO.,  
189 BROADWAY, NEW YORK.



### Imports and Exports for February, 1894, and the Preceding Eight Months.

WASHINGTON, D. C., April 7.—The summary statement of imports and exports for the month ending Feb. 28, 1894, and the eight months ending the same date, compared with the corresponding periods of 1893, has been issued and contains the following figures relative to the jewelry trade:

**IMPORTS:**—Diamonds and other precious stones, rough and uncut, including glaziers' and engravers' diamonds not set, and jewels to be used in the manufacture of watches, month of February, 1894, \$29,135 against \$90,089 same month of 1893, and \$64,662 in January; clocks and parts of, February, 1894, \$1,697 against \$9,877 same month of 1893, and \$2,579 in January; watches and parts of, and watch materials and movements, February, 1894, \$67,955 against \$117,270 same month of 1893, and \$76,515 in January; jewelry and manufactures of gold and silver February, 1894, \$39,544 against \$90,117 same month of 1893, and \$51,101 in January; precious stones and imitations of, not set, February, 1894, \$218,040 against \$1,294,126 same month last year, and \$193,865 in January.

**EXPORTS OF DOMESTIC MERCHANDISE:**—Clocks and parts of, February, 1894, \$71,678 against \$58,257 same month last year, and \$44,978 in January; watches and parts of, February, 1894, \$22,022 against \$8,374 same month last year, and \$16,998 in January; jewelry and manufactures of gold and sil-

ver, February, 1894, \$57,718 against \$50,322 same month last year, and \$53,268 in January; plated ware, February, 1894, \$16,340 against \$24,930 same month last year, and \$11,334 in January.

**IMPORTS, for eight months ending Feb. 28, 1894:**—Diamonds and other precious stones, rough and uncut, etc., \$330,174 against \$651,349 in 1893; clocks and parts of, etc., \$91,478 against \$195,608 in 1893; watches and parts of, etc., \$796,626 against \$1,163,501 in 1893; jewelry and manufactures of gold and silver, \$407,850 against \$475,914 in 1893; precious stones and imitations of, not set, \$2,376,601 against \$9,968,742 in 1893.

**EXPORTS OF DOMESTIC MERCHANDISE, for eight months ending Feb. 28, 1894.**—Clocks and parts of, \$573,368 against \$595,163 in 1893; watches and parts of, \$272,104 against \$121,199 in 1893; jewelry and manufactures of gold and silver, \$588,378 against \$454,671 in 1893; plated ware, \$204,663 against \$213,491 in 1893.

**EXPORTS OF FOREIGN MERCHANDISE.**—Diamonds and other precious stones, etc., February, 1894, nothing against nothing and \$20 against nothing for eight months; clocks and parts of, February, 1894, nothing against nothing in February, 1893, and \$165 against \$1,037 for eight months; watches and parts of, etc., February, 1894, \$47,934 against nothing in February, 1893, and \$48,560 against \$290 in eight months; jewelry and manufactures of gold and silver, February, 1894, \$588 against \$1,835, and \$13,282

against \$21,821 for eight months; precious stones, etc., February, 1894, nothing against nothing in February, 1893, and \$311,359 against \$1,561 for eight months.

The comparative summary of values of merchandise imported and exported during the eight months ending February 28th, from 1889 to 1894, inclusive, shows the following anent the jewelry and kindred lines: Average of the preceding five periods, imports, clocks and watches and parts of, \$1,473,813, eight months ending February 28, 1894, \$888,104; imports, jewelry, manufactures of gold and silver and precious stones, average of the five preceding periods, \$8,933,131, eight months ending February 28, 1894, \$2,784,451; exports, clocks and watches, average of the five preceding periods, \$924,589, eight months ending February 28, 1894, \$845,472.

### Ernst Schall's Interesting Suit Over a Check.

HARTFORD, Conn., April 5.—In the Common Pleas Court this morning before Judge Walsh, the case of Sherman & Crowley against the Ernst Schall Co., jewelers, was taken up. The case was tried before a justice and judgment given for the plaintiff. Defendant thereupon appealed to the Common Pleas Court. This is an action to recover the value of a check of the defendant for \$100. Last Fall one Michael Kelly came to Hartford and put up at the Brower House. He deposited in the Society for Savings a check for \$1,000 and another one on the State bank for like amount, both of which turned out to be of no value.

Backed up by the two bank books he went into the Schall Co.'s store and purchased goods to the amount of \$60. In payment he tendered a check for \$200. Mr. Schall accepted the check and in return gave Kelly his check for \$100 and the balance in money. Kelly also took the goods. Then he took Mr. Schall's check to Sherman & Crowley and paid his bill. When the proprietors of the Brower House presented the check for payment it was refused on the ground that it had been obtained by fraud. The police have been on the track of Kelly for some time and have found a pace in New York where he is sure to turn up in case he goes to that city.

### THE INTELLIGENCE OF BIRDS.

"Bur-rds is intilligent," Mrs. Brannigan observed as she encountered her friend, Mrs. O'Flaherty. "Ye can tache 'em annything. Me sister had wan as lives in a clock, an' phin it's toime to tell th' toime it comes out an' s'ays 'cuckoo' as many toimes as th' toime is."

"Dthot's wondherful," said Mrs. O'Flaherty.

"It is, indade," said Mrs. Brannigan. "An' th' wondherful par-rt ov it all is, it's only a wooden burr-rd at dthot!"

—Harper's Magazine.



Knives,  
Scissors,  
Hairpins,

IN Sterling • Silver.

Made in Quantities.

Sold in Quantities.

PRICES AS LOW AS CONSISTENT  
WITH BEST WORKMANSHIP.

Many Novelties in Small Wares.

ALWAYS SOMETHING NEW.

Knives in many patterns from \$6.00 to  
\$12.00 per dozen.

Scissors in all shapes and variety of  
designs, \$3.25 each.

J. N. PROVENZANO,  
39 UNION SQUARE.





**Connecticut.**

The Derby Silver Co.'s factory is running three days per week.

The Thomaston watch factory began last week running eight hours a day, five days a week.

On account of dull times the Westfield Plate Co., at Thompsonville, have temporarily laid off 26 of their employes.

M. L. Carter & Co. have opened a new jewelry store in Danbury, in the old store occupied by W. C. Barry & Co. recently.

S. A. Parsons, who has been with F. E. Burdick, Hartford, has taken a position with the Standard Jewelry Co., same city.

Alvin Taplin, for more than 25 years superintendent of the burner department of the Bristol Brass and Clock Co., Forestville, has tendered his resignation, which took effect April 1.

John J. Dunlap, Bridgeport, made an assignment in insolvency Friday. A statement of the liabilities and assets have not yet been filed. John H. Lee is the assignee.

Frederick H. Brown, the Colony St. jeweler, Meriden, is lying very ill at his home, 12 Randolph Ave. He is suffering with typhoid pneumonia and is considered to be in a critical condition.

W. F. Paddock, jeweler and optician, Bridgeport, in pursuance of his plan to devote himself to the optical business solely began Monday, April 9, selling off his entire stock of watches and jewelry at auction.

S. S. Newton, West Winsted, reached his 73d birthday last week. For the past 41 years he and his wife have been constant residents of that town, during which time Mr. Newton has been identified with the jewelry business.

The store of David Yudkin, jeweler and pawnbroker, Ansonia, was invaded by burglars Wednesday morning. The jewelry had been left in the window over night, a practice which THE CIRCULAR last week commented upon in terms of warning. The burglars smashed in the window and stripped it of everything of value in the shape of watches and jewelry. Mr. Yudkin heard the crash and gave the alarm, but the burglars escaped, taking with them a handful of watches and jewelry.

After having been engaged in the jewelry business for 20 years, L. V. B. Hubbard, Shelton, retired from it April 5th, disposing of the store which he has so long conducted and of his stock of goods to Burton S. Hall, who will conduct the business hereafter. Mr. Hubbard announces that his chief reason for retiring is his health, which continues poor, and he will hereafter devote himself exclusively to the optical business, which will permit of travel and change of scene and air.

The Valentine, Linsley Silver Co., of Wallingford, have just organized with a capital stock of \$12,000, 20 per cent. paid in. The shareholders and number of shares

taken by each are as follows: Edgar C. Valentine, 80 shares; Noah Linsley, 80; W. J. Leavenworth, 40; F. A. Wallace, 60; H. L. Wallace, 40; C. W. Leavenworth, 40; C. D. Morris, 40; Geo. M. Wallace, 60; John Barton, Jr., 40. The following were chosen the board of directors: F. A. Wallace, Col. W. J. Leavenworth, Noah Linsley, E. C. Valentine and Charles Morris.

President Wm. H. Watrous, of the Wm. Rogers Mfg. Co., Hartford, is now a full-fledged alderman, and in his ward at least politics are going to be clean and Republican interests advanced. "If every Republican does his duty," said Alderman Watrous "we will soon be able to disperse the know-

nothings who now have the country's interests in charge, and good times and good business will be bound to return." Democrat and Republican alike voted for Mr. Watrous and his election in a Democratic stronghold is a high tribute of the esteem of Hartford's voters.

When John Rauth, Jeffersonville, O., was forced to suspend business by pressing creditors he took \$600 worth of the stock, which by law is exempt from levy. Among his assets were a number of bills owed by good customers. These went to the officer making the levy, and it is these claims that are now, by due process of law, offered for sale.

**MATHEY BROS., MATHEZ & CO.,**

21 & 23 MAIDEN LANE, N. Y.  
BRASSUS, SWITZERLAND.

Manufacturers and Importers of  
Plain and Complicated  
WATCHES.  
**SPLITS**  
A SPECIALTY.

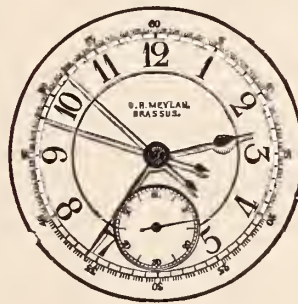

Sole Agents for **Jaques Lecoultre Razors.**

**THOMAS W. LIND,** Manufacturer of **Jewelers' Findings,**  
67 FRIENDSHIP STREET, PROVIDENCE, R. I.



FULL SIZE NEW ROCOCO.

Call or send for samples of my New ROCOCO PATTERNS, for Picture Frames, Cane Heads, Whips, Boxes, Napkin Rings, etc.

Large Assortment of TRIMMINGS for Millinery Ornaments, Scarf Pins, etc

Roosters and other  
Animal Figures in  
Great Variety.



Write us when you  
are in need of any-  
thing.



Ballet Dancers in Five Different Positions.



**DIAMONDS.****Wm. S. Hedges & Co.,  
Importers of Diamonds,**

And Manufacturers of DIAMOND JEWELRY.

**170 Broadway, New York.**

22 Holborn Viaduct, London.

**R. A. KIPLING,**

Importer of

**PRECIOUS STONES,****21 & 23 Maiden Lane,**19, RUE DROUOT,  
PARIS.

New York.

**ONE YEAR'S SUBSCRIPTION**

—TO—

**The Jewelers' Circular**

—At \$2.50,—

Entitles the subscriber to a copy of "WORKSHOP NOTES" free, a 200 page book, bound in cloth, containing a fund of information for the workshop that can be found in no other work.

**Alfred H. Smith & Co.,****IMPORTERS****DIAMONDS**

AND

**PRECIOUS STONES,****182 BROADWAY, COR. JOHN STREET,****NEW YORK.**

88 Holborn Viaduct, London, E. C.

**Trade Gossip.**

Geo. M. Baker, Providence, R. I., ably represented on the road by T. J. Gardiner, wants you to give him a trial on old gold, silver, sweeps, etc. He says he can prove to you that his results will exceed anticipations.

One of the newest and largest jewelry establishments in Wisconsin has just opened in Madison, with Nelson & Smith as proprietors. They have ordered one of Grout's Excelsior Louis XV. watch and spec. signs, for the top of a post on the walk in front of their place. This is one of the largest and showiest watch signs ever sent to Wisconsin, being about 15 feet to top of the sign.

Thos. W. Lind, Providence, R. I., has just finished another artistic border in the rococo style. It lends itself admirably to various purposes and is sure to become popular. A narrow border, also ready for delivery may be applied either entire or in half sections as desired, both being pretty and effective. In other lines Mr. Lind has now ready battle axes, in three sizes, with or without handles, which need only be seen to be appreciated. Send for samples.

One of the neatest things out this season is a silver match box with a cigar cutter combined. Those who enjoy a good cigar always want the tip cut neatly and smoothly, leaving the wrapper unbroken. Theodore W. Foster has shown THE CIRCULAR a box that he invented for his own use, but which proved so handy that he decided to place it upon the market; and his firm, Foster & Bailey, are now offering them for sale. Illustrations can be seen on page 3. This box is really the only one of its kind ever offered to the trade that works perfectly and drops the tips out without any trouble whatever. This firm are producing some beautiful goods in gold plate and also in sterling silver, 925-1000 fine. They show some things new in bracelets that are having a large sale.

The removal of I. Ollendorf, the well-known Pittsburgh jobber, from that city to 45 Maiden Lane, New York, is an event the like of which rarely occurs in the course of business. Mr. Ollendorf is now established in handsome offices on the second floor of the new building, 45 Maiden Lane, and will in a few days be comfortably settled. New and handsome fixtures make the premises artistic and cosy, and among the safes are two monsters, with all latest improvements, that in size are probably superior to any of the noted strong boxes on the Lane. Three hundred and fifty miles nearer the base of supplies and the opportunities ever offering in New York for the buyer with cash will, Mr. Ollendorf is confident, enable him to make both service and prices to his customers better than ever before. An addition has been made to the traveling staff, full particulars of which will be found in the travelers' column on another page.

**STERN BROS. & CO.**

CUTTERS OF

**DIAMONDS,**

WORKS:

29 &amp; 31 Gold Street,

33 to 43 Gold Street,

NEW YORK.

OFFICE,

30 MAIDEN LANE,

NEW YORK.

**BIG RETURNS MADE FOR OLD GOLD AND SILVER.**

Check Forwarded 24 Hours After Receipt of Consignment.

**J. RATHBONE,****GOLD AND SILVER REFINER, ASSAYER AND SWEEPSMELTER,**

Nos. 1 to 9 Matthewson St., Cor. Cove, Providence, R. I.



**Fashions in Jewelry and Silver-ware.**

A LADY'S RAMBLES AMONG THE JEWELERS.

The new glass ewers mounted in silver gilt are superb.

White linen finish springs into new life with the vernal equinox.

No ornament yet gives so much for the money as the turquoise. Hence it holds its own.

Silver gilt is exceedingly prominent. Entire silver services are displayed thus treated.

Small medicine cups of glass have silver covers with handles. These covers are a good idea.

Belt buckles in silver gilt and enriched with enamel, are new. They make a nice addition to the toilet.

A most beautiful brooch seen was of different tinted opals cut in geometrical forms connected with gold and small jewels.

Every woman who has a fine gold chain cut into segments by pearls, attached to her person, takes great care to show it.

A curious ornament seen was a sword hil only. It was almost as large as the palm of the hand and of solid diamonds.

Beer mugs in silver gilt, with covers and body enameled with the suggestive hop vine, are tokens of the high regard in which beer is held.

Rows of small pearls closely set and connected in segments by rectangular corners of semi-precious stones or carving, are among the new things.

The jewelers are having an admirable opportunity in the long, oblong and curving buckles that are now used in millinery and for the throat and belt.

Round sleeve buttons with turbine wheel designs in platinum overlaid on gold and a jeweled center are the best things seen of their kind.

A beautiful ornament was a flower spray of diamonds tied by a bow knot. The two ends were caught in a loop a few inches distant by a jeweled pin from which ten pearl tipped ends depended.

Just as low shoes are coming in there are the largest numbers of silver button hooks appearing. The fashion of spats may account for these. They are imposing articles for a dressing table.

A tea equipage seen that came from England was a two storied tray of lacquer. On the upper story which was half the size of the lower, stood the kettle, sugar and creamer. On the lower the pot, cups and saucers.

The prettiest baby rattle that can be conceived is a mother-of-pearl ring. On one side is carved a representation of the profile of the man in the moon. From the ring depend the various heavenly bodies, with jingling insides.

ELSIE BEE.

ESTABLISHED 50 YEARS.

**RANDEL, BAREMORE & BILLINGS,**

IMPORTERS OF

**DIAMONDS,**

AND OTHER PRECIOUS STONES.

**FINE PEARLS A SPECIALTY.**

MANUFACTURERS OF

**DIAMOND JEWELRY,**

IN THE LATEST DESIGNS.

Diamonds Recut in Modern Styles or Repaired on Premises.

58 Nassau Street,  
29 Maiden Lane  
NEW YORK.

1 Tulp Straat,  
AMSTERDAM.

1 St. Andrews St.,  
Holborn Circus,  
LONDON, E. C.

ESTABLISHED 1841.

**CARTER, SLOAN & CO.,**

**MANUFACTURERS OF GOLD JEWELRY,**

No. 15 MAIDEN LANE,

NEW YORK.

A. CARTER, JR.  
A. K. SLOAN.  
C. E. HASTINGS.

GEO. R. HOWE.  
WM. T. CARTER.  
WM. T. GOUGH.

FACTORY, NEWARK, N. J.



TRADE MARK.



**JOHN N. DISSELKOEN,**  
Cutter and Importer of  
**DIAMONDS**

FACTORY,  
76 LANGEBLEEKERSPAD  
AMSTERDAM.

19 East 16th St.,  
NEW YORK.

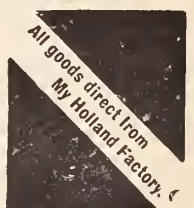



## SUGGESTIONS FOR WINDOW AND STORE DECORATION.

Members of the trade who think they have an attractive window are invited to send us a photograph, or a pen and ink or pencil sketch of the same, which will be published if we consider the window contains any originality or lesson.

### IDEA LXXI.

ALL the jewelers of Indianapolis, Ind., paid special attention to their Easter windows, those deserving special mention being Horace A. Comstock's and J. C. Walk & Son's. One of the most elaborate and beautiful windows ever seen in Indianapolis

blooming plants, the rich display of watches, jewelry, diamonds and other gems was reflected and re-reflected until the passers-by were lost in admiration. A large, beautiful bell, made of choice flowers, hung from the ceiling, bearing across it the



A WINDOW SUGGESTION FOR ALL FORTHCOMING EASERS.

was the Easter window conceived by Carl F. Walk and used by J. C. Walk & Son. The bottom was covered with white cloth, and in the rear was a curved mirror that extended across the window. Above the mirror was a shelf edged with heavy silver fringe. On the shelf were placed handsome pieces of bric-à-brac and potted plants in full bloom. The whole framework of the window was outlined in smilax and vines. The sparkling cut glass vases, full of flowers, handsome painted jardinières filled with

lettered scroll, Easter Bell. Suspended above the bell was a white dove, gracefully poised in its downward flight.

Mr. Comstock's window was extremely pretty and tasty. The bottom was covered with white cloth; in the center, on a raised revolving disk, was a tall, white plant, in full bloom, around the base of which were gracefully arranged chains and small jeweled watch cases. Blooming plants were placed at the back and sides of the window, while cut flowers, diamond pins and rings, hand-

painted penwipers and prayer book markers, arranged on the white cloth, made a most attractive display.

### Points of Law.

#### BONA FIDE PURCHASER OF CHECKS.

One who pays full value for a check is a bona fide purchaser, and takes free from all equity between the original parties.

*Davis v. Dayton, City Court of New York, General Term.*

#### PLEDGE OF WIFE'S PROPERTY TO SECURE HUSBAND'S DEBT.

Where a man and his wife pledge the personal property of both to secure the husband's debt, under an agreement that the wife's property shall be used to satisfy the debt only after the other property is exhausted, a judgment creditor of the husband cannot compel such pledge to exhaust the property of the wife before resorting to the husband's property in satisfaction of his debt.

*Buck v. Bransford, Supreme Court of Arkansas.*

#### LIABILITY OF WAREHOUSEMAN FOR LOSS OF GOODS.

A warehouseman, having a large quantity of goods in storage, removed from the warehouse at the expiration of his lease, and the new lessee was submitted as custodian of the goods, without the owner's consent. Subsequently they discovered that some of the goods were missing, and they sued the original warehouseman on the warehouse receipts. If the goods were missing at the time of the transfer to the new lessee, he was liable, otherwise not.

*Hoeveller v. Meyers, Supreme Court of Pennsylvania.*

#### WHAT CONSTITUTES SALE BY SAMPLE.

The circumstance, merely, that at the time of the sale a sample was produced, is not sufficient to constitute the sale one "by sample." To have that effect it must be fairly inferable that the parties mutually understood, or at least that the seller intended the buyer to understand, that the bulk of the commodity sold should be in kind and quality equal to the sample shown. That a portion of the bulk of the goods sold was examined by the buyer at the time is not conclusive that the sale was "by sample." Neither is a sale conclusively one "by sample" because, at the time of the sale a sample was produced, and it was inconvenient or impracticable to examine the bulk of the goods sold. The circumstances, however, should be duly considered in arriving at a conclusion that a sale was or was not one "by sample." The question, therefore, is in every case one of the intention of the parties, to be determined from the evidence.



### Pittsburgh.

C. H. Weinhaus has returned from the east.

Max Arnheim has recovered from his illness, and is about again.

Spencer Bros. have removed to 96 Fifth Ave., and are pleasantly located.

G. L. Ruff has opened a new store at 626 Penn Ave. He is a well-known jeweler in the city.

W. H. Milchsack has opened his new store at 69 Fifth Ave., and has very attractive quarters.

M. Marks, of Braddock, has given up the jewelry business to undertake that of haberdashery.

Morris J. Baer is the western representative for S. M. Einstein, Attleboro, and is handling a line of silver novelties.

W. W. Wattles, of W. W. Wattles & Sons, Fifth Ave., is at Atlantic City, and will make a short visit to New York before returning.

The engagement of J. Harvey Wattles to Miss Hurford, of Bellevue, Pa., is formally announced for the first time through THE CIRCULAR. The wedding will occur in a few months.

Buyers in the city last week were: E. C. Elliott, Belle Vernon, Va.; P. J. Manson, Jeannette, Pa.; R. Merrell, Jeannette, Pa.; A. Winter, Zelienople, Pa., and G. A. Spies, Irwin, Pa.

L. E. Harmon, West Newton, Pa., and M. G. Sell, West Farmington, O., bought large bills from a prominent Fifth Ave. wholesale firm, as they are opening new stores in their respective towns.

### Syracuse, N. Y.

A. Lesser's Sons will remove on May 1st to a fine suite of offices on the first floor of *The Herald* building.

Alfred C. Miller, formerly with C. E. Eager, but now with J. H. Johnston & Co., New York, arrived in town Saturday for a few days' stay with friends.

H. J. Howe has added an extensive line of fine stationery to his stock of jewelry and silverware. The engraving of calling and wedding cards and invitations will be made a feature of the new department.

### Canada and the Provinces.

T. A. Brady, representing Smith & Patterson, Montreal, has just returned from a successful trip to Ottawa.

George Chillas, representing in Canada the Pairpoint Mfg. Co., recently made a successful trip to Toronto, and Western Ontario.

J. C. Barlow, bookkeeper for A. R. Harmon, the Canadian representative of Robbins & Appleton, is confined to his residence suffering from a severe attack of the grip.

The jewelry establishment of W. S. Walker & Co., St. James St., Montreal, will

shortly be removed to St. Catherine St., next door to the new store of Henry Birks & Sons.

Mr. Cochenthaler, jeweler, Montreal, has returned from Philadelphia. His visit was in connection with the recent burglary in his store, some of the goods having been traced to that city.

Henry Birks, of Henry Birks & Sons, jewelers, Montreal, has returned from his Winter trip to England and the Continent. Mr. Birks will shortly take possession of his magnificent new premises at the corner of St. Catherine St and Phillips Sq.

John Wanless, the well-known jeweler, Toronto, has completed negotiations with Robert Simpson, the extensive dry goods dealer of that city, whereby the former transfers his building to the latter, receiving in return the building formerly occupied by Kent Bros., jewelers, and the sum of \$15,000 as well.

Adolphe Clement, Charles Renaud and Edmond St. Hilaire were tried in Montreal last Wednesday for selling bogus gold watches on the streets to innocent visitors from the country at big prices. The evidence was rather amusing, but the jury did not forget its duty and brought in a verdict of guilty. St. Hilaire was sentenced to two years in the penitentiary; Renaud and Clement got six months each with hard labor.

### Boston.

L. A. Hall & Co. have moved from Summer St. to 351 Washington St.

The premises occupied by Fred Heintz, manufacturing jeweler, 427 Washington St., third floor, were damaged by water Thursday night on the occasion of a fire in the building.

The E. Howard Watch & Clock Co. have just equipped the New York buildings of the Postal Telegraph Co. and Mutual Reserve Insurance Co. with regulators and electric time dials.

Buyers in town last week included: G. H. Pond, West Upton; C. F. Hopkins, Gloucester; J. M. Morrill, Morrill Bros., Concord, N. H.; George True, Clark & True, Middletown, Conn.

Harry H. Vaughan, salesman at Smith & Patterson's, who recently underwent a second operation on account of an unusually stubborn case of appendicitis from which he has suffered several months, is slowly improving.

Saturday the Crescent Watch Case Co. issued notices to the jobbing trade announcing the opening of their Boston office at 403 Washington St. It is understood that the quarters occupied by the Bay State Watch Case Co., which consolidated with the Crescent concern a few months ago, will be relinquished on the expiration of the lease at the close of the present month.

Fred. Michelson, Grand Island, Neb., announces his intention to go out of the jewelry business.

### "The Enterprising Burglar" Goes a-Burgling Again.

ROCHESTER, N. Y., April 5.—A burglar last night entered Lyke & Edmunds' jewelry store on the third floor of Powers' block and secured valuable booty. An entrance was gained to the room by climbing over the transom. It is thought probable that the marauder has employment in the block.

Two weeks ago last night the transom over the door of the office of S. & M. Schoenberg on the same floor as the business of Lyke & Edmunds, was forced open and the burglar climbed through it. The matter was reported to the police and Detective Long was detailed to investigate, but until last night nothing further was heard of the burglar. There were taken from Lyke & Edmunds' store a gold ring, a ladies' brooch set with gems, a gold necklace, a string of silver beads, and other small pieces of jewelry.

Geo. B. Shafer, Merrill, Wis., has sold his jewelry store to Edward Farber, of the same place.

## THE CHARMILLES WATCH



is a new departure in watchmaking. It is the invention of Albert H. Potter, one of the most celebrated and scientific watchmakers living, and is protected by numerous patents the world over. The movement and case are one and the same, thus permitting a *higher quality movement* at the expense of the case—producing a *finely finished solid nickel movement* cased in the least expensive and simplest form, giving a *better value for the money* than higher priced watches.

The stem winding and pendant hand setting mechanism is simple, durable and *positive in action* and is a feature of the watch.

It consists simply of two upright wheels set in a solid block, one engaging in an intermediate winding wheel, the other in an intermediate face wheel. Pulling the stem out engages the hand setting wheel, pushing it in engages the winding—each operation is *positive*—no jumping of hands.

This device is to be found *exclusively* in the "Charmilles" watch and only needs to be seen to be appreciated.

Because the *price is low* "Charmilles" watches must not be classed with the many inferior watches with which the market is flooded and the Jeweler's reputation jeopardized.

"Charmilles" watches are suited to the times—the *greatest value for the least money*.

Illustrated Price List with full descriptions and prices mailed upon application to any leading Jobber.

## The Latest Triumph.





Traveling representatives may consider these columns open for the publication of any news or items of interest regarding themselves or their conferees.

**I.** OLLENDORF, formerly of Pittsburgh, Pa., but now located in New York, has added to his force of travelers E. Webber, who will look after New England and A. Caro for New York, city. In addition, the regular salesmen will look after customers as follows: L. Warshawsky, in the west; W. Bickart, east except New England; B. Callomon, Western Pennsylvania and West Virginia.

Chas. E. Graff, representing the Waterbury Watch Co., was in Lynchburg, Va., Friday. He did a good business and states that trade is looking up all over the country.

Traveling men visiting Davenport, Ia., the past week were: C. B. Bartlett, Whiting Mfg. Co., New York; W. J. Carrow, Mandeville, Carrow & Crane, Newark, N. J.; C. H. Pixley, F. A. Hardy & Co., E. W. F. Adams, Simpson, Hall, Miller & Co., Wallingford, Conn.; E. A. Reed, Reed & Barton, Taunton, Mass.

The cards of the following jewelry drummers were left in Springfield, Mass., within the past week. F. H. Haddan, John Russell Cutlery Co.; H. C. Schwartz, Kremenz & Co.; C. H. Barney, Middletown Plate Co.; H. P. Howard, Towle Mfg. Co.; F. W. Bliss, Unger Bros.; George W. Smith, Carter, Sloan & Co.; H. E. Bleecker, the Bassett Jewelry Co.

Among the salesmen in Philadelphia the past week were: Frank Wood, Carter, Sloan & Co.; Ed. Elfeldt, Wm. B. Kerr & Co.; Ed. Ackley, Unger Bros.; Charles Duffy, Enos Richardson & Co.; J. E. Simonson, A. J. Hedges & Co.; E. S. Skinner, Elgin National Watch Co.; J. Cutler, Cutler & Lull; R. Thompson, for H. Glorieux; H. Somers; and F. Hoyt, of Hoyt & Weller.

Travelers in Boston the past week included: W. H. Tarlton, Wightman & Hough Co.; T. F. Fessenden; John A. Abel, Lewis, Kaiser & Luthy; H. Barker, John W. Reddall & Co.; C. L. Bleecker, W. S. Hedges & Co.; J. H. Cheney, Ludwig Nissen & Co.; Harry K. Ingraham, Alling & Co.; E. W. Martin, Martin, Copeland & Co.; Charles Bennett, Jacob Bennett & Son; Samuel L. Howland, Eisenmann Bros.; C. W. Cary, J. B. & S. M. Knowles Co.; Mr. Mowry, Kirby, Mowry & Co.; C. L. Power, Ludeke, & Power.

Traveling men in Pittsburgh, Pa., last week were: Mr. Mason, Dennison Mfg. Co.; Nat Prentiss, Alling & Co.; A. Bradshaw,

Meriden Britannia Co.; Rube Thompson, for Henry Glorieux; Mr. Kaufman, Bruhl Bros. & Co.; Jean Kingman, G. A. Dean & Co.; Luther Hyde, Reed & Barton; Mr. Baldwin, Hayden W. Wheeler & Co.; H. A. Bliss, Kremenz & Co.; S. W. Abbey, E. Ira Richards & Co.; Mr. Corey, Corey & Osmun; A. A. Wood, Howard Sterling Co.; A. W. Wagner, Leon J. Glaenger & Co.; B. M. Henschel, Wm. Morris & Co.; Simon A. Ier, B. H. Davis & Co.; W. A. Elliott, Adelphi Silver Plate Co.; B. E. Osgood, Bioren Bros.; C. A. Boynton, Wm. B. Kerr & Co.; M. Stratton, Jr., John W. Reddall & Co.; and S. M. Einstein.

Traveling men noticed in Syracuse, N. Y., the past week included: G. H. Linton, F. M. Whiting & Co.; Mr. Smith, The Holmes & Edwards Silver Co.; R. T. Supple, Wm. B. Durgin; Harry C. Larter, Hayden W. Wheeler & Co.; Mr. Harris, J. Goldberg; D. Cohn, Stone Bros.; Mr. Horton, J. B. Bowden & Co.; E. L. Brown, Manasseh Levy; George S. Melville, The Acme Silver Plate Co.; J. H. Astruck; H. C. Barnum, Shafer & Douglas; Otto H. Wolff, Bippart & Co.; A. L. Halstead, Barbour Silver Co.; Chas. Van Ness, Reeves & Sillocks; S. Glenn Walmsley, Tenner & Baum; W. S. Campbell, Day & Clark; Mr. Peabody, French & Franklin Mfg. Co.; Mr. Wilson, Geneva Optical Co.; Mr. Schutz, E. L. Logee & Co.; L. M. Jacoby, Providence Stock Co.; F. S. Sherry, Jos. Fahys & Co.; Mr. Cohen, H. Ludwig Co.; Mr. Whiting, Wade, Davis & Co.; Leopold Laubheim, Adolph Goldsmith & Son; M. Adler; E. Kiel, White, Howard & Major; Theodore Parker, Martin, Copeland & Co.; M. L. Hammel, Keller, Ettinger & Fink.

### Newark's Republican Candidate for Mayor.

**T**HE Newark *Sunday Call* (Ind.), has the following to say of the Republican candidate for Mayor of Newark, Julius A. Lebkuecher, of Kremenz & Co.:

The Republican candidate, Julius A. Lebkuecher, is about 50 years old, and a partner in the jewelry manufacturing firm of Kremenz & Co. He was born in Germany, was brought to this country when a babe, and was educated in Newark's public schools. He has been a very active and successful business man, a leading resident of his section of the city, and an active Republican. He has kept out of political office because he was devoted to business, but he has taken part in local affairs more or less earnestly. He is treasurer of the Fourteenth Ward Building and Loan Association, a director in financial institutions, and a keen observer and very capable man in all business affairs. Personally, he is rather under medium height, and has a clear eye, a direct look and a frank manner.

All who know him have the highest esteem for him, and while the politicians are not familiar with him, he has a wide circle of personal friends and business associates.

He was one of the Citizens' Committee asked to investigate the Ivy Hill reservoir and water contract, and expressed his opinions against the reservoir scheme and for enforcement of the water contract fully in the committee's report. On street railroad affairs he is entirely untrammelled, and has made his views clear, by declaring the full enforcements of agreements, and for the rights of passengers to transfers, and the city to its taxes promptly paid. In short, Mr. Lebkuecher is a first-rate business man, with natural independence and force of character, ample to secure the city's rights, and the Republicans and Independents feel entirely satisfied with him as a candidate.

### The Death of Alexander Krailsheimer.

Alexander Krailsheimer, who for eighteen years represented Lissauer & Sondheim and their successors, Lissauer & Co., New York, as traveler in the west and northwest, died March 18, 1894, at Stuttgart, Germany. Mr. Krailsheimer was widely known and well liked throughout the jewelry trade.

Deceased was born in Stuttgart, thirty nine years ago. He came to America in 1871 and four years later entered the employ of Lissauer & Sondheim, where he remained until 1891. His health became low, and then upon the doctor's advice he went to Europe intending to return in a short time. He grew gradually worse, however, and remained in Stuttgart with his parents until his death.

### Summary Action on the Part of Customs Officials.

A seizure was made last week by Custom House Inspectors McDonald and Cooper, who Thursday visited the jewelry store of C. W. Schumann's Sons, at 937 Broadway, New York, and carried away paintings, bronzes and Japanese ivory carvings of the estimated value of \$17,000. The goods were taken out of the store, placed in a truck and taken to the seizure room of the Custom House.

Mr. Schumann explained that the property was not his nor was it for sale. It belongs to a Mr. Levison, a retired jeweler of San Francisco, who is fitting up a house up-town and for whom he was taking care of the goods until the house is ready for occupancy.

The officers, however, insisted on taking the property claiming that they were dutiable goods on which no duty had been paid.

Wm. Smith & Co., 5 Maiden Lane, New York, have a varied and salable line of sterling silver novelties. The designs are artistic and pleasing and the goods themselves have been well received. The line includes combs, umbrella straps, hat pins, satchel tags, hat and coat marks, bracelets, vest chains, etc. Wm. Smith & Co. also show some handsome things in the fashionable lorgnettes, with and without pearls, in cable, open curb, fox tail and rope patterns. Do not fail to inspect the line.



### News Gleanings.

G. A. Sauer is a new jeweler in Mifflintown, Pa.

Fred Witherstine will open a jewelry store in Iliou, N. Y., about May 1.

Caleb Dickinson, Plainfield, N. J., has moved from Park Ave. to 122 North Ave.

Milton Meyer & Co., 14 E. Hanover St., Trenton, N. J., have assigned to George W. Keeler.

S. W. Cushing, Vergennes, Vt., is closing out his business on account of ill health.

The stores of E. L. Penner and J. J. Gray, Barry, Ill., were burned out a few days ago.

I. R. Prindle, Great Barrington, Mass., has been making some improvements in his jewelry store.

H. N. Bolte, jeweler, 912 Atlantic Ave., Atlantic City, N. J., will soon have his new brick store finished.

Stonington, Conn., is to have a new watch maker and repairer in the person of Mr. Latham, of Noank.

L. J. Giering, Bethlehem, Pa., is advertising an auction sale, being conducted by Col. J. M. Rutherford.

In a fire in Cuero, Tex., a few days ago, the store of H. Solfen was affected to the extent of \$600; no insurance.

In a destructive fire in Lancaster, N. Y., April 4, the jewelry store of Anton Bussman suffered to the extent of \$5,000.

W. A. Fisher, Tionesta, Pa., has disposed of his stock at auction and left for Wheeling, W. Va., where he expects to locate.

W. H. Elliott, Manchester, N. H., announces by advertisement that he is about to retire from the jewelry business.

Brehmer Brothers, Rutland, Vt., have removed their stock into one side of Hill & Co.'s store, on Merchant's Row.

S. W. Cushing, Vergennes, Vt., has moved to Athol, Mass., and assumed charge of the jewelry business of E. E. Cleveland.

George Mundy, Somerville, N. J., has removed from 33 to 63 Main St., in the Hardcastle building opposite the post office.

C. M. Brown's jewelry store, Greensboro, N. C., was visited by thieves a few days ago, and jewelry was stolen to the amount of \$200.

Andrew Beck, jeweler, Mamaroneck, N. J., has bought the business block where he is located, the consideration being \$5,000.

Oneida Community Limited, Niagara Silver Plate Co., report number of employes 375; wages paid \$88,900; value of output \$510,000.

S. H. Baynard, jeweler, Wilmington, Del., recently purchased some land in the northwest part of the city supposed to contain kaolin.

Fire damaged Deal Bros.' drug and jewelry stock, Carthage, Mo., a few days ago to the extent of \$8,000 to \$10,000; insured

for \$9,000.

I. J. Hare's building at Chester, Pa., is in the hands of the painters and decorators, while improvements are to be made to the interior of the store.

Fred and Robert Bleuer, young jewelers of Rock Island, Ill., have decided to embark in business on their own account. They open up April 15th in a desirable location.

Ira L. Green, St. Regis Falls, N. Y., has sold his store to L. M. Wardner, and has purchased a jewelry business in Watertown, to which he will remove about the middle of April.

The jewelry store of T. V. Dickinson, at Niagara Falls, N. Y., is not affected by his Buffalo failure. The stock is owned by his daughter, who does business under her father's name.

The Guinand & Teetor Co., of Des Moines, Ia., have filed articles of incorporation with the county recorder. The business of the company will be to deal in jewelry; \$5,000 is the capital stock.

D. B. Ryland, A. J. Rankin and Jno. Katz, Jr., Lynchburg, Va., have formed a limited partnership under the name of Ryland & Rankin. The last gentleman is special partner for \$4,000. The partnership will exist three years from March 15, 1894.

Mr. Blakstone, the practical watchmaker and jeweler who worked formerly for Baldwin & Co., St. Joseph, Mo., and lately for Edwards & Sloane Jewelry Co., Kansas City, Mo., has opened a repair shop in Frances St., between 5th and 6th St. St. Joseph.

Charles G. Willson, Reading, Pa., has completed the class pins for the class of '94 of the High School. The design is very pretty, being an antique shield bearing the initials "R. H. S.," in orange and Nile green, with "1894" in the corner in black.

About 2 o'clock last Saturday morning fire broke out in the clothing and jewelry store of Wineberg & Heyman, Little Falls, N. Y. The fire resulted in the total demolition of the interior of the first and part of the second stories of the building. The loss sustained by Wineberg & Heyman is about \$10,000; insured.

Orr L. Keith, West Branch, Ia., closed his jewelry store as usual last Saturday evening. Sunday morning the doors were found to be open, in front and rear, the safe had been blown open, and everything valuable was taken. The ledger was carried off, probably to conceal the numbers of the watches taken. The value of the goods, including watches and other jewelry, was about \$700.

By the death of Miss Estella A. Fry, only daughter of Frank H. Fry, the well-known jeweler of Burlington, N. J., on Monday afternoon, April 2d, a sweet young life full of promise, was suddenly cut off. Miss Fry was socially popular and was an interesting worker in church circles. She was an accomplished musician and painter. A host of friends, who sympathize with the bereaved family, mourn her loss.

### Queries by Circular Readers.

*Editor of THE JEWELERS' CIRCULAR:*

Will you please give us the address of manufacturer of Birch watch keys. They were advertised in your paper some time ago.

MEINECKE & Co.

ANSWER:—Kendrick & Davis, Lebanon, N. H. now make the Birch Watch Keys.

*Editor of THE JEWELERS' CIRCULAR:*

There is a small black wooden cased clock made by the Jerome Clock Co. with what is called a flying pendulum. The clock is marked Pat. 9th Oct., 1883. Can you tell us whether the pendulum (which is only useful as a novelty) has been patented, and if so, if the patent is yet in force?

BRITTON BROS.

ANSWER:—J. C. Slafter, Minneapolis, Minn., is the patentee of the device you refer to. If you will communicate with him he will give you all information desired.

*Editor of THE JEWELERS' CIRCULAR:*

Can you inform me of the origin of the custom of giving engagement rings?

A. Z.

ANSWER:—In William Jones' remarkable work, "Finger-Ring Lore," under the chapter devoted to betrothal and wedding rings is the following:

"As pledges of betrothal or wedding gifts, rings are of very ancient origin. They were worn by the Jews prior to Christian times, and constitute even at present an important feature in their marriage ceremonials. Wheatley says: 'The reason why a ring was pitched upon for the pledge, rather than anything else, was because anciently the ring was a seal, by which all orders were signed, and things of value secured, and, therefore, the delivery of it was a sign that the person to whom it was given was admitted into the highest friendship and trust. For which reason it was adopted as a ceremony in marriage to denote that the wife, in consideration of being espoused to the man, was admitted as a sharer in her husband's counsels, and a joint partner in his honor and estate, and therefore we find that not only the ring, but the keys were, in former times, delivered to her at the marriage.'

"A passage in Ruth (chap. iv, verse 7), gives some reason to suppose that the ring was used by the Jews, as a covenant, in making agreements, grants, etc., whence the wedding engagement by a ring may have been derived. Leo Modena, in his 'History of the Rites, Customs and Manner of Life of the Present Jews throughout the World,' (translated by Edna Chilmead, London, 1650), alluding to the Jewish manner of marrying, states that 'before the bride's dowry is produced and read, the bridegroom putteth a ring upon her finger, in the presence of two witnesses, which commonly used to be the Rabbines, saying withal unto her: "Behold thou art my espoused wife, according to the custom of Moses and of Israel."'

E. P. Bevilard, Elmira, N. Y. is going out of business.



# CLASSIFIED INDEX TO ADVERTISEMENTS.

All Advertisements are entitled to one insertion under proper heading. Extra insertions, \$6.00 per annum.  
Extra Headings, \$12.00 per annum.

|                                                                            | Page. |                                                                          | Page. |                                                                          | Page.    |
|----------------------------------------------------------------------------|-------|--------------------------------------------------------------------------|-------|--------------------------------------------------------------------------|----------|
| <b>Art Pottery, Bric-a-brac, Etc.</b>                                      |       | <b>Hotels.</b>                                                           |       | <b>Silver Plated Ware.</b>                                               |          |
| Ahrenfeldt, Charles & Son, 50-52-54 Murray St., N. Y. ....                 | 38    | Gibson House, Cincinnati, O. ....                                        | 22    | Pairpoint Mfg. Co., New Bedford, Mass. ....                              | 5        |
| Bing, Ferdinand & Co., 106 Grand St., N. Y. ....                           | 38    | <b>Jewelers' Findings.</b>                                               |       | <b>Sterling Silver Novelties.</b>                                        |          |
| Haviland & Abbot, 29 Barclay St., N. Y. ....                               | 41    | Lind, Thos. W., Providence, R. I. ....                                   | 25    | Codding Bros. & Heilborn, North Attleboro Mass. ....                     | 42       |
| Healey, M. & E., Washington, D. C. ....                                    | 37    | <b>Jewelry, Silverware and Optical Cases.</b>                            |       | Sedgwick, Clarence W., 11 E. 20th St., N. Y. ....                        | 38       |
| Hinrichs & Co., 29 & 31 Park Place, N. Y. ....                             | 43    | Steinhaus, Theo. C., 10 Maiden Lane, N. Y. ...                           | 4     | <b>Sterling Silverware.</b>                                              |          |
| Straus, L. & Sons, 42 to 48 Warren St., N. Y. ....                         | 37    | Jackson, S. C., 180 Broadway, N. Y. ....                                 | 43    | Alvin Mfg. Co., 860 Broadway, N. Y. ....                                 | 8        |
| Vantine, A. A. & Co., 877-79 Broadway, N. Y. ....                          | 41    | <b>Jobbers, Watches, Diamonds, Etc.</b>                                  |       | Campbell-Metcalf Silver Co., Providence, R. I. ....                      | 2        |
| <b>Assayers &amp; Refiners.</b>                                            |       | Allen, Benj. & Co., Chicago, Ill. ....                                   | 19    | Durgin, Wm. B., Concord, N. H. ....                                      | 42       |
| Baker, Geo. M., Providence, R. I. ....                                     | 17    | Brethauer Watch and Jewelry Co., Chicago, Ill. ....                      | 20    | Knowles, J. B. & S. M. Co., Silversmiths' Hall, Union Square, N. Y. .... | 7        |
| Clark, J. L., Philadelphia, Pa. ....                                       | 37    | Cross & Beguelin, 17 Maiden Lane, N. Y. ....                             | 2     | Niagara Silver Co., 454 Main St., Niagara Falls, N. Y. ....              | 40       |
| Rathbone, J., Providence, R. I. ....                                       | 26    | Freund, Max & Co., 8 Maiden Lane, N. Y. ....                             | 4     | Reed & Barton, 37 Union Square, N. Y. ....                               | 20       |
| Schawel, J. & Co., 29 John St., N. Y. ....                                 | 44    | Myers, S. F. & Co., 48 Maiden Lane, N. Y. ....                           | 44    | Shiebler, Geo. W., Co., 179 Broadway, N. Y. ...                          | 4        |
| <b>Auctioneers.</b>                                                        |       | Oppenheimer Bros. & Veith, 35 Maiden Lane, N. Y. ....                    | 44    | Towle Mfg. Co., Newburyport, Mass. ....                                  | 43       |
| American Syndicate of Jewelers' Auctioneers, New York and Washington. .... | 2     | <b>Leather and Silver Goods.</b>                                         |       | Wallace, R. & Sons Mfg. Co., 3 Park Place, N. Y. ....                    | 6        |
| Comrie, A. J., 182 Broadway, N. Y. ....                                    | 43    | Deutsch Bros., 7 E. 17th St., N. Y. ....                                 | 2     | Whiting, F. M. & Co., North Attleboro, Mass. ....                        | 10       |
| Lusk, G. W., 501 Masonic Temple, Chicago, Ill. ....                        | 21    | <b>Musical Boxes.</b>                                                    |       | Wood & Hughes, 16 John St., N. Y. ....                                   | 37       |
| Prince, J., 137 Broadway, N. Y. ....                                       | 44    | Jacot & Son, 39 Union Square, N. Y. ....                                 | 2     | <b>Show Cases.</b>                                                       |          |
| Scott, De B. O., 20 Murray St., N. Y. ....                                 | 44    | <b>Office Furniture.</b>                                                 |       | Smith, B. & W. B., 220 W. 29th St., N. Y. ....                           | 44       |
| <b>Badges, Medals, Etc.</b>                                                |       | Schwartzwelder & Co., New York. ....                                     | 38    | <b>Spectacle and Eyeglass Cases.</b>                                     |          |
| Irons & Russell, Providence, R. I. ....                                    | 37    | <b>Optical Goods.</b>                                                    |       | Birmingham, Wm. & Co., 728 Arch St., Phila. ....                         | 44       |
| Stockwell, E. R., 19 John St., N. Y. ....                                  | 44    | Berger, Albert & Co., 47 Maiden Lane, N. Y. ...                          | 43    | White, W. B. & Son, Boston, Mass. ....                                   | 42       |
| <b>Clocks, French, English and American.</b>                               |       | Kirstein's, H. E., Sons Co., Rochester, N. Y. ...                        | 37    | <b>Stem Winding Attachments.</b>                                         |          |
| Jacques, Chas., Clock Co., 22 Cortlandt St., N. Y. ....                    | 44    | McIntire & Ulmer, cor. 8th and Sansom Sts., Philadelphia, Pa. ....       | 43    | Abbott, Henry, 2 Maiden Lane, N. Y. ....                                 | 43       |
| <b>Diamond &amp; Precious Stone Importers.</b>                             |       | Queen & Co., Philadelphia, Pa. ....                                      | 43    | <b>Tortoise Shell Goods.</b>                                             |          |
| Disselkoen, John N., 19 E. 16th St., N. Y. ....                            | 27    | Spencer Optical Mfg. Co., 15 Maiden Lane, N. Y. ...                      | 4     | Potter, W. K., Providence, R. I. ....                                    | 5        |
| Falkenau, Oppenheimer & Co., 40 Maiden Lane, N. Y. ....                    | 44    | <b>Paneled Metal.</b>                                                    |       | Rice & Hochster, 485 Broadway. ....                                      | 9        |
| Hedges, Wm. S. & Co., 170 Broadway, N. Y. ...                              | 26    | Northrop, A. & Co., Pittsburgh, Pa. ....                                 | 43    | <b>Tool Manufacturers and Dealers.</b>                                   |          |
| Kipling, R. A., Hays Bldg., N. Y. ....                                     | 26    | <b>Paper Boxes.</b>                                                      |       | American Watch Tool Co., Waltham, Mass. ...                              | 37       |
| Randel, Baremore & Billings, 29 Maiden Lane                                | 27    | Warner Bros., Bridgeport, Conn. ....                                     | 38    | Bullock, O. W. & Co., Springfield, Mass. ....                            | 44       |
| Smith, Alfred H. & Co., 182 Broadway, N. Y. ...                            | 26    | <b>Pens, Pencil Cases, Etc.</b>                                          |       | Hardinge Bros., Chicago, Ill. ....                                       | 20       |
| Stern Bros. & Co., 30 Maiden Lane, N. Y. ....                              | 26    | The Boston Pen Co., Boston, Mass. ....                                   | 37    | Logan, A. J., Waltham, Mass. ....                                        | 5        |
| Tannenbaum, L., & Co., cor. Maiden Lane and Nassau St., N. Y. ....         | 15    | <b>Patents.</b>                                                          |       | Moseley & Co., Elgin, Ill. ....                                          | 22       |
| <b>Fine Stationery.</b>                                                    |       | Belt, C. T., Washington, D. C. ....                                      | 5     | Oliver, W. W., Buffalo, N. Y. ....                                       | 22       |
| Parsons & Greene Co., 18 Murray St., N. Y. ....                            | 5     | <b>Photo-Miniatures.</b>                                                 |       | Waltham Watch Tool Co. ....                                              | 7        |
| <b>Gold and Silver Plating Works.</b>                                      |       | Favre, Leon, 107 E. 26th St., N. Y. City. ....                           | 7     | <b>Trunks and Traveling Bags.</b>                                        |          |
| Bolstad Mfg. & Plating Co., Chicago, Ill. ....                             | 23    | <b>Platinum Importers.</b>                                               |       | Crouch & Fitzgerald, 161 Broadway, N. Y. ....                            | 5        |
| <b>Gold and Rolled Plate Jewelry.</b>                                      |       | Schawel, J. & Co., 29 John St., N. Y. ....                               | 44    | <b>Watch Manufacturers.</b>                                              |          |
| Foster & Bailey, Providence, R. I. ....                                    | 3     | <b>Ring Makers.</b>                                                      |       | Charmilles Watch. ....                                                   | 8, 29    |
| <b>Gold Jewelry.</b>                                                       |       | Bryant, M. B. & Co., 10 Maiden Lane, N. Y. ...                           | 37    | <b>Watch Case Manufacturers.</b>                                         |          |
| Carter, Sloan & Co., 15 Maiden Lane, N. Y. ...                             | 27    | Bowden, J. B. & Co., 192 Broadway, N. Y. ....                            | 7     | Roy Watch Case Co., 21 Maiden Lane, N. Y. ....                           | 7, 9, 22 |
| Johnson R. M., 67 Washington St., Chicago, Ill. ....                       | 20    | <b>Sample Trunks.</b>                                                    |       | Wadsworth Watch Case Co., Newport, Ky. ....                              | 21       |
| Krementz & Co., 182 Broadway, N. Y. ....                                   | 2     | Crouch & Fitzgerald, 161 Broadway, N. Y. ...                             | 5     | <b>Watch Case Repairers.</b>                                             |          |
| Pfeil, Chas. H., Chicago, Ill. ....                                        | 21    | <b>Silver Mounted Ebony Goods.</b>                                       |       | The Planchamp & Becker Co., Chicago, Ill. ....                           | 20       |
| Unger Bros., 192 Broadway, N. Y. ....                                      | 12    | Deutsch Bros., 7 E. 17th St., N. Y. ....                                 | 2     | <b>Watchman's Clocks.</b>                                                |          |
| Webster, G. A., Chicago, Ill. ....                                         | 43    | <b>Silver Novelties.</b>                                                 |       | Hausburg, O. E., 41 Maiden Lane, N. Y. ....                              | 43       |
| <b>Horological Schools.</b>                                                |       | Provenzano, J. N., 39 Union Square, N. Y. ...                            | 24    | <b>Watch Importers.</b>                                                  |          |
| American Horological Institute, Lancaster, Pa. ....                        | 22    | <b>Sterling Silverware.</b>                                              |       | Hyde's, J. E., Sons, 22 Maiden Lane, N. Y. ...                           | 38       |
| Chicago Watchmakers' Institute, Chicago, Ill. ....                         | 20    | Alvin Mfg. Co., 860 Broadway, N. Y. ....                                 | 8     | Mathey Bros., Mathez & Co., 21 & 23 Maiden Lane, N. Y. ....              | 25       |
| Elgin Horological School, Elgin, Ill. ....                                 | 23    | Campbell-Metcalf Silver Co., Providence, R. I. ....                      | 2     | Robert, Edmond E., 21 Maiden Lane, N. Y. ...                             | 44       |
| Parson's School for Watchmakers, Peoria, Ill. ....                         | 21    | Durgin, Wm. B., Concord, N. H. ....                                      | 42    | <b>Watch Keys.</b>                                                       |          |
| Philadelphia College of Horology, 623 Heed Building, Phila., Pa. ....      | 43    | Knowles, J. B. & S. M. Co., Silversmiths' Hall, Union Square, N. Y. .... | 7     | Clark, A. N., Plainville, Conn. ....                                     | 2        |
|                                                                            |       | Niagara Silver Co., 454 Main St., Niagara Falls, N. Y. ....              | 40    | <b>Watch Repairers.</b>                                                  |          |
|                                                                            |       | Reed & Barton, 37 Union Square, N. Y. ....                               | 20    | Muller, Hugo, Chicago, Ill. ....                                         | 21       |
|                                                                            |       | Shiebler, Geo. W., Co., 179 Broadway, N. Y. ...                          | 4     |                                                                          |          |
|                                                                            |       | Towle Mfg. Co., Newburyport, Mass. ....                                  | 43    |                                                                          |          |
|                                                                            |       | Wallace, R. & Sons Mfg. Co., 3 Park Place, N. Y. ....                    | 6     |                                                                          |          |
|                                                                            |       | Whiting, F. M. & Co., North Attleboro, Mass. ....                        | 10    |                                                                          |          |
|                                                                            |       | Wood & Hughes, 16 John St., N. Y. ....                                   | 37    |                                                                          |          |



## Special Notices.

Rates 75c. per insertion for notices not exceeding 5 lines (25 words), additional words 2 cents each. If answers are to be forwarded, postage stamps must be enclosed. Two insertions, 15 per cent. off; three insertions, 20 per cent. off; four insertions or more, 25 per cent. off. Payable strictly in advance. Display cards on this page will be charged at \$2.00 per inch for first insertion, subject to same discount as above for subsequent insertions.

Under the heading of **Situations Wanted** on this page advertisements will be inserted for **One Cent a Word**. This offer refers to **Situations Wanted only**. Payable strictly in advance. If answers are to be forwarded, postage must be enclosed.

## Situations Wanted.

Notices under this heading **ONLY** are charged at one cent a word, payable strictly in advance. If answer are to be forwarded, postage must be enclosed.

**WANTED, SITUATION**—Manager of a business for two years past. Do all branches of work—watchmaking, engraving, seal making, jobbing, selling, buying. Box 695, What Cheer, Ia.

**WANTED** by a first-class watchmaker, with an excellent equipment of tools, a place in a first-class jewelry establishment, New York or Brooklyn preferred. Samples of workmanship sent for inspection, if required. Address W. H., No. 7 Decatur St., Brooklyn, N. Y.

**SITUATION WANTED** as watch and clock maker; also jewelry repairer; age 21; speaks English and German; good references. Address A. Guenther, 875 Sixth Ave., New York.

**POSITION WANTED** in a retail jewelry store as salesman or at the bench. Five years' experience. Address F., care of THE JEWELERS' CIRCULAR.

**YOUNG MAN** wants position where he can learn the jeweler's trade. Good engraver; have samples. Good references, and industrious. Address Engraver, care of THE JEWELERS' CIRCULAR.

**SITUATION WANTED** as engraver and watchmaker with good house; have lathe, bench, tools, etc.; do all kinds of watchwork and engraving; pierced monograms and dies for stationery. Address Racso, care of THE JEWELERS' CIRCULAR.

**ENGRAVER**, All Lettering in all its branches. Monograms, ciphers and ornamental work. Also capable of doing copper plate and die cutting for stationery trade. Open for engagement after May 1st. Address J. J. M., care THE JEWELERS' CIRCULAR.

**A COMPETENT WATCHMAKER** would like a position; 18 years' experience on fine and complicated work; perfect set of tools. Address Curtis, care of THE JEWELERS' CIRCULAR.

**AN OPTICIAN AND WATCHMAKER**. About May 1. Charge of optical department in jewelry or optical store, or go on the road. E. T. Smith, 109 Cedar St., Corning, N. Y.

**FIRST-CLASS** practical lapper and polisher wants position; used to all kinds of best diamond mountings; capable of taking charge of polishing department; would go anywhere for good position. Address Practical, 7 Clifton Ave., Newark, N. J.

**WANTED AT ONCE**, by a young man of twenty-three a place to complete trade under a good man. Three years' experience at bench; can do ordinary hard solder and clock repairing; also salesman. Best of references. Address H. Bruns, 133 Main St., Columbia, S. C.

**WANTED**.—Position by thorough, practical watchmaker, of seven or ten years' experience at the bench; full set of tools. First-class references. Address C., care of THE JEWELERS' CIRCULAR.

**WORK WANTED FOR JEWELERS, SILVERSMITHS, ENGRAVERS, DESIGNERS, WATCHMAKERS, CASEMAKERS, TOOLMAKERS, ETC. ONLY WORKMEN WITH GOOD TESTIMONIALS FROM PREVIOUS EMPLOYERS ARE RECOMMENDED.**  
ADDRESS,  
**JEWELERS' RELIEF ASSOCIATION,**  
111 MAIDEN LANE, N. Y.

## Help Wanted.

**WANTED**.—A salesman traveling through Southern States selling retail jewelry trade to take a side line. Address B., care of THE JEWELERS' CIRCULAR.

**WANTED, A WINDOW DRESSER**.—Professional preferred; although those having had a little experience, with good ideas, may apply. Permanent position guaranteed to capable party. Address Spartan, care of THE JEWELERS' CIRCULAR.

**OPTICAL SALESMEN WANTED**.—Experienced men having trade in Eastern, Middle and Southern States. Address Queen & Co., 1010 Chestnut St., Philadelphia.

## To Let

**TO LET**.—A large office, 20 x 40, first floor, No. 11 Maiden Lane. \$60 a month.

**BROADWAY STORE** near the Post Office; desirable location; moderate rent; lease. Apply on premises, 2 Astor House.

**TO LET**.—Part of office 15 Maiden Lane; steam heat, also burglar alarm. For particulars apply to Martin, Copeland & Co., 15 Maiden Lane, City.

**TO LET**.—Part of factory, with steam power. Center of jewelry district. Moderate rent. J. F. Newman, 19 John St.

**FINE OFFICE** for manufacturer's agent, 16 x 12 feet; vault and all conveniences. Champlain Building, cor. State and Madison Sts. Rent, \$25.00. Will take merchandise for rent. S. N. Clarkson, 182 State St., Chicago, Ill.

## Miscellaneous.

**I BUY JEWELRY STOCKS**—Manufacturers, jobbers and retailers desiring to dispose of surplus or entire stocks of diamonds, watches and jewelry can find quick cash buyer by addressing Stephen S. Harmon, 134 East 96th St., New York City.

**STOLEN**—A gold watch, 14 karat case. Marked inside E. T. E. B. E. C. No. 634,923. E. Howard & Co. movement, No. 220,614. The watch needed repairs; make note of numbers so as to stop it if offered. A suitable reward for its recovery. Address B. P. O. Box 284, Hartford, Conn.

## DEMAGNETIZING.

**PERFECT WORK**—Watch repairing in all its branches; all work warranted. Winslow & Penney, 608 Masonic Temple, Chicago.

**FOURTEEN karat gold solder** that will flow on eight karat work; makes a hard solder job a pleasure. With this solder there is no danger of melting low karat specs. No white joints on rings. It is just what you want. Sample by mail 25 cents. F. W. Hall, Sterling Silver Novelties, Columbus Memorial Building, Chicago, Ill.

**WANTED TO PURCHASE**.—Good paying jewelry store for cash in New York or Brooklyn. Address L. B., care THE JEWELERS' CIRCULAR.

## For Sale.

**ATTENTION**, Watch Case Makers and Jobbers. Will sell, low, one circular and one straight-line engine turning lathe, in good condition. Charles Perret, 180 Broadway.

**FOR SALE**.—Rare bargain. Our old plate glass jewelers' showcases and counters. Hyman, Berg & Co., State and Washington Sts., Chicago, Ill.

**FOR SALE**.—An old established jewelry store in a city of over 20,000 inhabitants near Boston. Inventory about \$6,000. Address "Snap," care of THE JEWELERS' CIRCULAR.

**FOR SALE**.—Do you want it? Lovely cottage near State Park, Adirondacks. Pure air; pure water; no malaria; no mosquitoes; fine hunting and trout fishing; price \$2,000; cost \$3,000. P. O. Box 26, Wevertown, N. Y.

\$500 will buy the fixtures and good will of jewelry store; large Marvin safe, electric clock, electric lights and all modern fixtures; repairing will average \$40 weekly; rent only \$22.50 per month. Am the inventor of several patents which require my attention. Apply to B. H. Berkman, 56 Vernon Ave., Long Island City.

**FOR SALE**.—Jeweler's safe; 4 ft. 7 in. high, 3 ft. wide. Burglar-proof chest, double combination lock. Price, \$100. Also three counter and upright showcases. J. C. Proudman, 307 Eighth Ave., New York City.

\$450 buys a stock of jewelry and fixtures in a town of 1,000 inhabitants; no other watchmaker within 25 miles of me. Address at once C. R. Keil, Thorpe, Wis.

## FOR SALE—TOWER CLOCK.

Made by the Howard Clock Co.; dial trains, connecting rods and hands for two 3-foot dials; suitable for store front, church public building; in use only nine months; will be sold cheap.

**HENRY ABBOTT,**

No. 2 Maiden Lane, New York.

**\$5,000** for long established retail Jewelry business in city of 100,000 inhabitants;

**YEARLY PROFIT ABOVE EXPENSE, \$3,500.** Can be greatly increased by additional capital if desired.

Satisfactory reasons for selling given to parties with necessary cash capital. Address,

**CHANCE**, care of THE JEWELERS' CIRCULAR.

## SAFES FOR SALE.

(CHOICE OF TWO.)

Will sell at one-fifth the original cost; size, 56x38 inside measurement. Apply to or address,

**OPPORTUNITY,**

Care THE JEWELERS' CIRCULAR.

## FOR SALE,

The Old Established Jewelry Business of G. A. SCHULTZ (Dec'd), is for sale at a great bargain. New fixtures throughout; good location. Address

**HELENA SCHULTZ, Ex'trix,**  
Corner 7th & Market Streets, LOUISVILLE, KY.

## TO LET! PART OF STORE.

**Chas. Jacques Clock Co.**

22 CORTLANDT STREET, NEW YORK.

## Cheap, Bright Offices To Let

singly or in suites, in the handsome new buildings,  
**14 and 45 MAIDEN LANE.**

Rents \$350 up; elevator, steam heat, electric lights, etc. E. A. CRUIKSHANK & CO., 176 Broadway.

## TO LET!

**ENTIRE SECOND FLOOR, WITH STEAM POWER, IN THE JEWELRY MANUFACTURING BUILDING, REAR OF**

**17 JOHN STREET,**

Apply to **ENGINEER** on the premises.

## TO LET.

**FACTORY ROOM WITH POWER.**

Elevators, Steam Heat, Watchman, Automatic Fire Sprinklers and good light. Cor. York and Washington Streets, Brooklyn—near the Bridge, within 12 minutes of N. Y. City Hall. For information, apply at Factory, or 198 Broadway, N. Y.

**Ketchum & McDougall.**



## Jeweled Orders and Decorations.

ORDERS and decorations, although usually regarded as constituting a peculiarly and exclusively masculine form of pomp and vanity, are likewise a charming and very popular article of feminine adornment, and while stars and ribbons look exceedingly well on men, serving to lighten up the somewhat sombre hue of ordinary evening dress, they are seen to infinitely greater advantage on the corsage of ladies' dinner and ball dresses, says a writer in the *New York Tribune*. The decoration differs from an ordinary article of jewelry in that it cannot be bought. An order constitutes either a token of imperial or royal esteem and regard, or else an indication of the possession of a long line of blue-blooded ancestors both on the paternal and maternal sides, untainted by any plebeian strain. Those women, therefore, who are entitled to wear these orders and decorations, invariably prove an object of jealousy and envy to those who are less favored and less highly born, and is there anything that is more calculated to make the fair Decorée or Dame Chanoinesse feel pleased and happy than the knowledge that she possesses something that is beyond the reach of the majority of women around her?

Although nearly every monarchical country of Europe has its feminine order, the Grand Mistress of which is invariably the consort of the sovereign, yet the number of Dames Chevalières, of Chanoineses, on the whole, is extraordinarily small, and this naturally contributes to render them very conspicuous and observed figures whenever they appear in society. Limited in Europe as is the number of ladies entitled to pin jewel badges and stars to their corsages, in this country they are still fewer; barely half a dozen, in fact. One of them is Baroness Stumm, the American-born wife of the former German ambassador to Madrid, who has the Spanish Order of Marie Louise, as has also Mrs. Burd Grubb, the English better half of the general of that name. Lady Randolph Churchill has the Order of the Crown of India, which she received from Queen Victoria at the time when her husband was Secretary of State for India, and then there are Mrs. "Sunset" Cox, Mrs. Lew Wallace and others who have been decorated by the Sultan with the Turkish Order of the Chefakat. Nor should I omit the name of the wife of Senator Joseph Hawley, who has the English Order of the Red Cross, received for her services as a hospital nurse in England prior to her marriage.

With regard to England, the orders for women are of quite modern creation, the principal one, that of Victoria and Albert, having been founded in 1862, that of the Crown of India in 1878 and the Royal Red Cross in 1883. None of them confer any rank, title or precedence, prerogatives which can be dispensed with by the Dames Chevalières of the first two of the above mentioned orders, seeing that they are

ladies who possess these attributes, independent of their decoration. The Order of Victoria and Albert consists of a medallion portrait of the Queen and of her husband, surmounted by a royal crown and attached to the left shoulder of the dress by a bow of thick white satin. The first two classes are restricted exclusively to royal personages and have the portrait encircled with diamonds. The third class is conferred only upon peeresses of the realm, while the fourth is reserved for the ladies of the bed-chamber and maids of honor of the Queen, the diamonds being replaced by pearls in both of the latter grades.

The Imperial Order of the Crown of India is conferred only upon the ladies of royal rank and upon the wives or daughters of native princes of the Indian Empire and of British dignitaries who have been connected with the administration of that great dependency. It consists of the Queen's cipher V. R. I., in diamonds, pearls and turquoises encircled by a border set with pearls, surmounted by a jeweled Imperial crown and worn attached to the left shoulder by a bow of light blue watered ribbon edged with white. The Red Cross is conferred upon women who have distinguished themselves in the nursing of the sick and of wounded soldiers and sailors. It consists of a cross of enameled crimson edged with gold, having on the arms thereof the words institution of the decoration, the center containing a medallion of the Queen. It is worn on the left shoulder, attached by a bow of dark blue ribbon edged with red, and among its members are: Miss Florence Nightingale, Mrs. Grimwood, the heroine of the Manipur massacre in India; the wife of Senator Hawley, Lady Roberts and a number of Roman Catholic Sisters of Mercy.

Very effective is the Order of Marie Louise, conferred by the Queen Regent of Spain, and which is possessed, as stated above, by Baroness Stumm, daughter of the New York banker, J. von Hoffmann, and by the English-born wife of General E. Bu.d Grubb. The insignia consists of an enameled star worn on the left breast and a blue and white striped ribbon worn over the right shoulder, crossing the breast and back of the dress to the left hip, where it unites in a rosette, whence depends the silver and gilt enameled cross of the order. The Order of St. Catharine of Russia, founded as far back as 1714, and of St. Isabelle of Portugal, instituted in the first year of this century, are worn in the same manner. In connection with the Portuguese order it may be mentioned that one of the most recent accessions thereto is Mme. Carnot, her patent being signed by the Grand Mistress of the Order, the Queen of Portugal, whose father, the Comte de Paris, is exiled from France by a decree bearing the signature of President Carnot.

The correct title of the Sultan's order for women is that of Nichan-i-Chefakat, and its members comprise most of the ladies of the reigning families of Europe as well as the wives of great statesmen and diplomatic

dignitaries, among its possessors being the Marchioness of Dufferin, Baroness Burdett-Coutts, the Comtesse de Montebello and the Marchioness of Salisbury. It consists of a star with six points, worn on the left shoulder and of a cordon crossing the right shoulder and fastened by the badge of the order on the left hip.

It is needless to enumerate here the score or so of women who have been decorated with the French Cross of the Legion of Honor, since that is not a distinctly feminine order, as are those which have been referred to. The Chevalières in question are either Sisters of Mercy and vivandières, who have distinguished themselves by their devotion to the wounded on the field of battle, or are ladies such as Mme. Heine and Mme. Koechlin-Schwartz, who have earned a similar claim to national esteem and regard by the foundation and maintenance of numerous charitable institutions. The explorer of Persia, Mme. Dieulafoy, and the celebrated animal painter, Rosa Bonheur, are likewise Chevalières of the Legion of Honor.

## The Filing and Tempering of Steel Parts.

THE repairer is occasionally compelled to file and temper steel parts for stem-winding and repetition mechanisms; for instance, a spring or lever, which on account of their very varying shapes are not to be had in the material stores, so that the repairer must make one or the other himself. A simple method, which can also be made use of by workmen of little experience, is as follows: The broken spring or complicated steel part is first moistened with soldering fluid and a slight coating of solder supplied. The sheet steel for the new part is then filed flat upon the one side, in the same way moistened with soldering fluid and slightly coated with solder. The former is then laid, well fitted together, upon the small piece of sheet steel and firmly soldered on; the contours are next filed out of the sheet steel with a sharp file, the necessary holes for screws or footpins drilled, after which the spring is loosened.

In order to obtain a good temper and desirable elasticity for parts that require it, the following process is recommended very highly: The springs and other steel parts of all kinds for watches or clocks, are first heated strongly, then well rubbed over with ordinary soap, heated to a cherry red, and quickly dipped into petroleum, without the fear that it will ignite. The tempering in petroleum has the advantage that the steel parts do not become twisted, and remain perfectly white; they are therefore at once ready for annealing. The springs are upon the annealing plate or broad clock spring annealed light blue, quickly coated with tallow, and burned off twice. Springs treated in this manner will never break.

In manners, tranquility is the supreme power.—*Mme. de Maintenon*.



**The Latest Patents.**

ISSUE OF APRIL 3, 1894.

**517,430. EYEGLASSES.** BENAJAH U. BUGBEE, and JOSEPH RENO, Southbridge, Mass., assignors to the Southbridge Optical Company, same place.—Filed May 27, 1893. Serial No. 475,739. (No model.)

In eyeglasses, the eye wire divided on its inner side and provided with a post constructed of two members arranged to rest one upon the other, the upper member



having its upper surface recessed, and constructed to receive the end of the spring connecting the eye wires, and each member of the post having a screw threaded perforation approximately vertical or at right angles thereto, the parts being constructed to be held together by a single screw which passes down through the end of the nose spring and is threaded into the members of the post.

**517,480. ELECTRIC SYNCHRONIZER FOR CLOCKS.** HENRY S. PRENTISS, Elizabeth, N. J., assignor to the Prentiss Clock Improvement Company, New York, N. Y., and Jersey City, N. J.—Filed Nov. 3, 1892. Serial No. 450,894. (No model.)

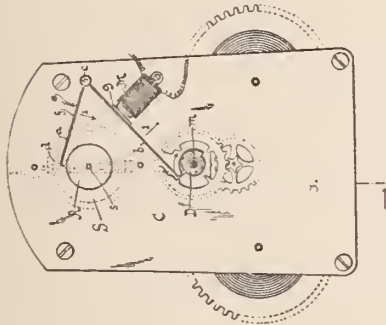

In a clock system, a master clock provided with a circuit closer adapted to close the circuit at a predetermined period before the hour and to break it at the hour, and a secondary clock (or clocks) provided with a detent adapted to arrest the motion of the train, an electro-magnet in connection with the circuit closer of the master clock and arranged to act on said detent, and a device actuated by the train of the secondary clock, and placed in connection with the detent to permit motion of the latter under the influence of the electro-magnet at the hour as indicated by the secondary clock and for a predetermined period thereafter.

**517,554. WATCHCASE-SPRING.** CHARLES NOBS, Newark, N. J. Filed June 19, 1893. Serial No. 478,044. (No model.)



A watch case spring provided with a holding lip, and a reduced portion at one end of said spring, a tongue on said reduced portion, and said reduced portion being adapted to overlap part of the opposite and free end portion of the spring.

**517,594. CLOCK.** JOB SMITH, Annapolis, Md., assignor of one-half to Walter J. Wertz, same place. Filed May 4, 1893. Serial No. 473,040. (No model.)

In a magic clock, the combination of an hour hand of tubular form, a minute hand adjacent thereto, and also of tubular form, and containing the clock mechanism entire, a tubular shaft passing through the clock mechanism and two hands, the said minute hand having a contracted tubular extension E<sup>2</sup>, a stem winding spindle E<sup>1</sup>, rotably mounted in said tubular extension,

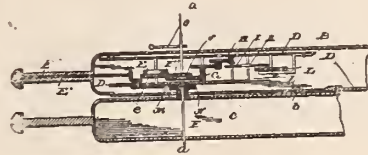

and an actuating stem winding mechanism, and a counter balance weight O, mounted on said tubular shaft, said hands being adapted to be turned either to the right or left without affecting the interior mechanism.

**517,617. WATCH-MOVEMENT BOX.** EZRA C. FITCH, Newton, Mass.—Filed Sept. 19, 1892. Serial No. 446,295. (No model.)

A box for the protection and display of watch movements, comprising in its construction a body portion having its base bent to form an inwardly projecting flange, a cover fitting closely over the body portion and having its upper edge bent to form an inwardly pro-

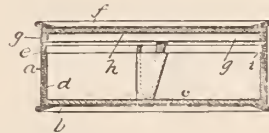

jecting flange, transparent top and bottom plates resting against said flanges, and internal rings adapted to hold the top and bottom plates against said flanges, the said box being adapted to confine the case shoulder of a watch between its internal projections carried by the body portion and cover.

**517,680. ENGRAVING-MACHINE.** HENRY A. CHASE, Brooklyn, assignor to William A. Force & Co., New York, N. Y.—Filed May 29, 1893. Serial No. 475,954. (No model.)

**517,686. TOOL FOR ORNAMENTING WATCHCASES.** FREDERIC ECAUBERT, Brooklyn, N. Y.—Filed Feb. 13, 1888. Serial No. 263,867. (No model.)

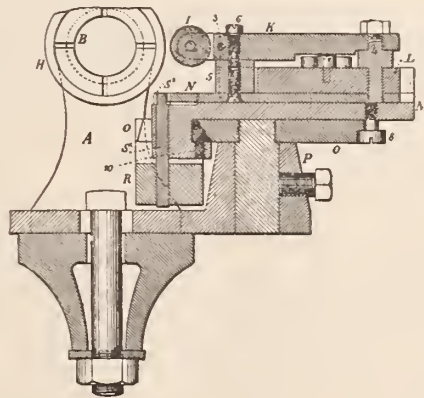

The combination with the knurl or ornamenting wheel and the mandrel and chuck or tool for holding the watch case center or other article to be ornamented, of a rotating shaft and adjustable crank pin and a rigid connecting rod extending from the crank pin and provided with rack teeth, a pinion upon the mandrel engaging the rack teeth, and a roller adjacent to the pinion for holding the rack to the pinion.

**517,725. SCARF-PIN.** HENRY BORNSTEIN, Boston, Mass.—Filed Oct. 17, 1893. Serial No. 488,383. (No model.)

As an improved article of manufacture, a safety pin for scarfs and other purposes, consisting of a pointed shank A, a downwardly projecting front prong A<sup>2</sup>, a bent or curved portion A<sup>3</sup> connecting the shank and front prong and lying substantially in the plane thereof, and a projecting shank B provided with a setting and rigidly fixed on the said front prong between



the pointed extremity thereof and the bent or curved portion which connects the front prong with the shank A.

**DESIGN 23,163. SPOON, FORK, ETC.** SIDNEY SMITH, Bridgeport, Conn., assignor to the Holmes & Edwards Silver Co., same place.—Filed March

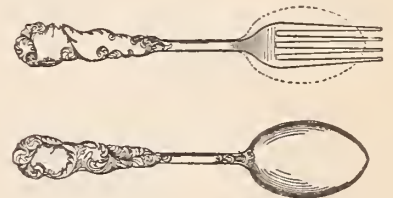

1, 1894. Serial No. 501,998. Term of patent years.

**TRADEMARK 24,436. WATCHCASES.** ILLINOIS WATCH CASE CO., Elgin, Ill.—Filed March 5, 1894.

**ELGIN GIANT.**

*Essential feature.*—The words "ELGIN GIANT." Used since June 1, 1891.

**TRADEMARK 24,438. AGATE BEADS AND BUTTONS.** F. BAPTEROSSES & CIE, Paris, France.—Filed March 6, 1894.



*Essential feature.*—The representation of a plurality of figures having six equal faces, and in the center of which is the design of a duck. Used since November 1, 1893.

**Expired Patents.**

EXPIRED APRIL 3, 1894; GRANTED APRIL 3, 1877.

**189,108. EYEGLASSES.** IRA H. JOHANNES, Washington, D. C., assignor of one-half his right to R. T. Waters, Baltimore, Md.—Filed Feb. 26, 1877.



In eyeglass frames, the combination of bows or other devices for holding the glasses, pads or rests for supporting the frames upon the nose, and ball and socket joints for uniting the pads to the bows.



### Different Shapes of Chamfering Tools.

As is well known, says Claudius Saunier, this is used for removing the roughness that a drill leaves at the edge of a hole or to take off the cutting edge round a screw-head, sink, etc., thus forming a bevel edge. The tool commonly has a flat semi-circular blade, the diameter of which depends on the size of the hole to be made; this semi-circle is ground to a cutting edge like a drill, as shown at *a*, Fig. 1. Chamfering tools are also made pyramidal with flat faces as at *b* and *c*; the angle at the apex is more

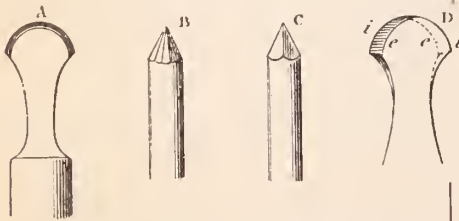

FIG. 1.

or less acute according to the depth of chamfer required. The oil cup drills *d* and *f* are also used for chamfering the edge of a hole.

A cone formed at the extremity of a piece of cone wire with a cutting edge on each leaf and hardened will be found very useful for this purpose. The two forms of chamfering tool first described leave a series of undulations on the bevel edge, so that instead of being conical, it presents a number of small facets. This inconvenience can

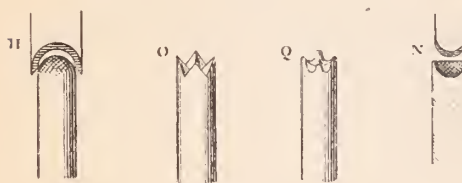

FIG. 3.

be avoided by using the tool shown at *Z*, Fig. 2.

A small disc of hardened steel is pivoted within a recess formed at the end of a rod, the pin on which it rotates being at right angles to the direction of the rod. As is seen in the figure to the right of *Z*, the section of this roller is a rectangle, and the surface is carefully polished, the edges being left sharp. It may be worked by hand or with a bow.

Clockmakers make use of a tool for forming oil-cups that only differs from the one above described in two particulars: 1, the disc is fixed on its axis; and 2, the edge, instead of being square to the two faces, is inclined as shown at *g*, and at the same time is slightly rounded crosswise. A few trials will be found necessary before the most convenient thickness and inclination are arrived at.

The repairer is also frequently called on to use hollow chamfering tools, which, as is well known, are used for removing the angles at the ends of cylindrical rods, of

steady-pins, etc., or for rounding them off. Three forms are shown at *o*, *g*, *n*, Fig. 3; *o* is a round rod the flat end of which has been filed across with the corner of a triangular file. Fine cutting edges are thus produced which will act on the end of any object that rotates within them, or *vice versa*. If it be required to form a very acute angle, two slits must be cut with a screw-head file, and the sides afterward inclined to the required extent with a flat file. This tool will serve a double purpose: 1st, to chamfer off the edge of a rod; and 2d, by prolonging the operation to form a point at the end.

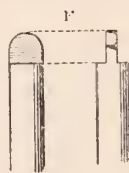

FIG. 2.

As a rule, when it is desired to round off say, a pillar of a clock after reducing its length or from any other cause, a hollow chamfering tool of very open angle is used, a rocking motion being imparted to it round the axis of the spindle; it is better to use a tool of the shape shown at *n* or *g*. The latter, *g*, is easily formed by strokes of a rat-tail file at right angles across its end; the other, *n*, is cut internally with a shaped chisel or with a small rotating cutter to which different inclinations are given during the cutting, as is also done when using the chisel.

The tool shown at *o* has been modified as follows: The two notches at right-angles are replaced by three equidistant notches of equal depth. To make these in a piece of round steel it should be divided on the circumference into six equal parts; then cut the three notches as follows: Calling the points marked on the circumferences 1, 2, 3, 4, 5, 6, one notch will lie parallel to the line joining 1, 3, and equidistant between this line and the point 5; a second will be parallel to 3, 5, and midway between that line and point 1, and the third will be parallel to 5, 1, and midway between this and the point 3.

The strike of the silk weavers has affected the supply of one of the most popular of the novelties handled by jewelers, inasmuch as it has almost bared the market of the silk webbing used in sterling silver mounted belts. Fortunately for the trade, however, Unger Bros., Corbin building, Broadway and John St., New York, have still on hand a nominal supply of the *moiré antique* silk ribbon, from which, while it lasts, they will continue to fill orders at prices previously charged for the plain belting. Jewelers should be quick to take advantage of these conditions.

The greatest misfortunes men fall into arise from themselves.—*Steele*.

### Workshop Notes.

**To Temper a Long and Thin Piece of Steel.**—To harden a long and thin piece of steel, such as a small French clock pinion, without getting it out of shape, is a most difficult, and it may be said, a very hazardous operation, but still it may be done. The first necessity, if it is to be heated in an open fire, is to have a uniform heat. It is preferable to heat the steel in a brass tube filled with charcoal. The tube must have the perforation not much larger than the object to be hardened and must be of considerable solidity, as the charcoal without a good body of metal would be a poor conductor of heat. The fluid to be used in the process of hardening should be linseed oil, cottonseed oil, or, the best of all, castor oil mixed with kerosene in proportions of about one-half the castor oil to one of kerosene. It has been observed that small steel objects spring more in hardening by being plunged into a thin, quickly cooling fluid, such as water, etc. By the use of castor oil we have a thick, slowly cooling fluid, while the admixture of kerosene oil imparts a high degree of hardness and toughness. When used, most remarkable results may be expected from this mixture, and it is well worthy of a trial. It is always of paramount importance in performing the operation of hardening a delicate piece without injury, to heat and cool all parts of the article simultaneously.

**Cyanide for Cleaning.**—Although cyanide of potassium, in the proportion of two ounces to one quart of water, is frequently used for cleaning watches, still its use is not to be recommended, as its careless use may injure the gilding, if not entirely remove it. If every trace is not removed, after its use, by hot water, alcohol, etc., the parts are sure to tarnish badly and the steel will rust speedily. It is far better and safer to use benzine and alcohol, and finish up with dry bone dust. A mutton bone, calcined in a slow fire will have a coating of fine dust on its surface, which, when applied with a soft brush to the gilding, will impart a superior luster, and its use does not leave anything behind which could either injure the steel or the gilded parts in the least. Precipitated chalk mixed with alcohol and used moderately is also an excellent medium to remove grease or stains from gilded or polished brass. Strong caustics or acids of any kind are always to be avoided as much as possible in watch work, and their presence on the watchmaker's bench is very much to be deprecated. A clean brush is of paramount importance in all cases.

**Mainspring to be put in.**—When a mainspring is to be put in, care should be taken not to move the regulator when removing the balance. Put in the new spring the same length and strength as the old one. Oil it and wind it up three or four times to test it before replacing the barrel. The cannon pinion can best be tightened by rolling the part between two files.





TRADE MARK.

# L. STRAUS & SONS,



TRADE MARK

IMPORTERS AND MANUFACTURERS,

China, Pottery and Glassware, 42, 44, 46 & 48 Warren St. and 116 Chambers St., N. Y.  
PARIS, CARLSBAD, RUDOLSTADT, LIMOGES, STEINSCHONAU.

**WOOD & HUGHES,**  
STERLING SILVERWARE MANUFACTURERS  
New York Agents for the Derby Silver Co.'s  
FINE QUADRUPLE PLATED WARE,  
No. 16 JOHN STREET, NEW YORK.  
206 Kearney St., San Francisco, Cal.  
HASKELL & MUEGGE, Agents.



**IRONS & RUSSELL,**  
(SUCCESSORS TO CHARLES F. IRONS.)  
MANUFACTURERS OF  
SOLID GOLD **EMBLEMS** ROLL PLATE  
PINS, CHARMS AND SOLID GOLD RINGS.  
102 Friendship Street, - - Providence, R. I.



## The "Bryant" Rings.



Are widely advertised and will sell  
when anything will, therefore  
every Retail Jeweler should buy them.

IF NOT CALLED UPON BY OUR TRAVELERS  
ORDER DIRECT FROM

**M. B. BRYANT & CO.,** 10 MAIDEN LANE, N. Y.  
OLDEST RING MAKERS IN AMERICA.



ESTABLISHED 1870.

**J. L. CLARK,**  
SWEEP SMELTER AND REFINER OF GOLD AND SILVER.  
Buys every kind of Gold and Silverware, Jewelry, Watches and Platinum. Full market value paid.

No. 724 Filbert Street, Philadelphia, Pa.  
SEND BY EXPRESS or Registered Mail. If my price is not satisfactory, I will return all articles.



STRONGEST GUARANTEES.

Quality  
Maintained.  
Prices to  
Suit the Times.

Ask for our New  
Prices and  
Terms for 1894.

**American Watch Tool Company,**  
Chymistry Dist., Waltham, Mass., Stoney Batter Works.

**CHRYSO-CERAMICS,**  
GOLD COVERED PORCELAIN.

**M. & E. HEALEY,**  
1122 CONNECTICUT AVE., WASHINGTON, D. C.  
MEDAL AT WORLD'S COLUMBIAN EXPOSITION.

**VICTOR.** SIMPLEST FEED. ALWAYS THE SAME.  
GUARANTEED FOR ONE YEAR.  
**THE VICTOR FOUNTAIN PEN**  
(Pat. Feb. 4, 1890.)

**THE BOSTON PEN CO.,**  
N. C. Whitaker & Co., Proprietors.  
363 Washington Street, Boston, Mass.  
Manufacturers of finest quality  
TORTOISE : SHELL : AND : HORN : GOODS  
in every variety. Also Aluminum Hair Pins.  
Send for illustrated Pen Price List No. 1.

When  
Prompt and perfect description  
Work is wanted,

SEND TO  
**E. KIRSTEIN'S SONS CO.,**  
ROCHESTER, N. Y.

Price List now out.



# FERDINAND BING & Co.,

106 GRAND ST., N. Y.

—NEW DESIGNS IN—

China Clocks and Gilt Bronze Sets, Fine Painted Dresden Goods in Vases, Cups and Saucers, and Plates; Cararra Marble Statuary, French Cabinets and other Fancy Furniture.

## Jules Jürgensen

OF COPENHAGEN

The reputation these watches have maintained for Fifty Years has never been equalled, being made on strictly scientific principles and no expense spared to give the Best results in mechanism and timekeeping qualities.

SOLE AGENTS.

John C. Hyde's Sons,  
NO. 22 MAIDEN LANE.

## WM. SCHWARZWAELDER & CO.,

Fulton St., cor. Pearl, - NEW YORK

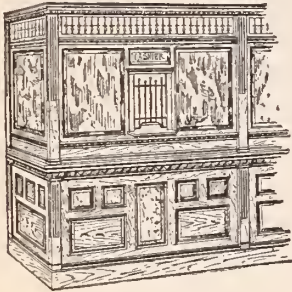

MANUFACTURERS OF

DESKS, CHAIRS, Etc.

Jewelers' Cases and Counters, Office Partitions, Rails, Etc.

Special Designs, Plans, Prices, etc. upon application.



\$4.50

Per Dozen.

Sterling Silver "TROLLEY" or Hat Guard for Straw Hats, unlimited Sale THIS YEAR. Gold and Silver Art Match Boxes, Diamond and Half Pearl Brooches, Swords and Scarf Pins. Repairing a Specialty.

CLARENCE W. SEDGWICK,

11 EAST 20th ST., - NEW YORK.

## Paper Boxes

At Prices Which Defy  
Competition.

Plain and Fancy Silverware Boxes

FOR MANUFACTURERS USE

OUR SPECIALTY.

Our large dealings in Satins, Silks and Sateens in the Corset Business, together with special machinery, enable us to do the BEST OF WORK AT LOW PRICES. Quotations promptly furnished upon receipt of sample.



Address

Warner Bros.,

Bridgeport, Conn.

Box Department.

# CHARLES AHRENFELDT & SON

50, 52 & 54 Murray Street, New York.

.... IMPORTERS OF ....

# China, Glass AND Bric-a-Brac,

ESPECIALLY ADAPTED TO THE JEWELRY TRADE.





## The Rambler's Notes.

WHAT THE RAMBLER SAW AND HEARD AMONG THE DEALERS IN ART POTTERY, CUT GLASS, BRONZES, ETC.

### THE BEAUTY OF DELFT WARE.

**D**ELFT WARE has been famous and popular for centuries, and though the industry has greatly decayed and diminished in its native home in Holland, the manufacture of this ware in other parts of Europe has greatly increased, particularly within the past few years. The attractiveness of Delft is strongly shown in the magnificent display made by Chas. Ahrenfeldt & Son, 52 Murray St., New York. Large vases, ewers, urns and covered jugs can here be seen in great variety and in artistic shapes of which many are exact counterparts of pieces made centuries ago. In the same way smaller pieces as tea caddies, candlesticks, cabinet and fancy ornaments, jardinières, etc. are shown in both ancient and modern styles. The line also contains many pieces entirely up to date, in which the blue decoration of Delft is most becoming; among these are handsome plate glass mirrors with Delft frames, letter files, ink stands, bonbon boxes and picture frames. Some of the most striking shapes are to be seen in the picture and mirror frames and the line of boudoir mantel clocks. Other pieces suitable for jewelers include representations of musical instruments, miniature furniture, lamps and jewel boxes.

\*

### FRENCH CHINA SPECIALTIES.

**T**RAYS and picture frames are among the French china specialties for jewelers of which F. W. Büning & Co., 58 Murray St., New York, are showing a rich and extensive variety. The extensive assortment of pen, desk and brush and comb trays show shapes both round and square with gilt, *bleu de four*, floral and incrustated gold decorations. Some in Empire green and gilt are extremely pretty, as are others with cupid, figure or scenery panels. The new photo frames, both double and single, contain a great variety of rococo and other artistic shapes. The

decorations on these consist of fine floral designs or of gilt, of a fine scroll work, sometimes of raised gold. The body of the frames are either white or colored, the principal shades being dark blue and green.

\*

### DRESDEN LACE FIGURES AND MINIATURE OBJECTS.

A specialty of Dresden miniature furniture, instruments, coaches, etc., which form a line of fancy ornaments which is both attractive and salable. This line which includes also jewel boxes, representations of musical instruments and various utensils, is tastefully decorated with raised or plain floral designs principally in forget-me-not types. Other pieces, larger but similarly decorated, are banquet and boudoir lamps and candelabra. In this connection mention should also be made of the Dresden lace figures, single pieces, pairs and groups, which are also extensively shown. The subjects of many are extremely natural, among these being ballet girls, Turks and Japanese characters, while others are ideal, as the cupids and angels. All are delicate and pleasing.

\*

### ARTISTIC FRENCH CHINA.

**S**OME appropriate and artistic effects are to be seen in the French china fish sets of A. Klingenberg, 35 Park Place, New York. The decorations on the borders of the dishes are raised and consist of a combination of shell and water effect. The paintings in the center show various scenes of fish in water. The color on some sets is a sea green, while others are white, shading into blue and gold. A new lily-of-the-valley decoration is the prevailing ornamentation in the French china dinner ware, table novelties, sets and fancy pieces here shown. It extends even to the larger vases and flower holders, and is also shown upon a line of Teplitz art pottery. The popularity of this decoration is in great part due to its being the fashionable shade of green in a natural combination with one of the most delicate and beautiful of the floral designs.

THE RAMBLER.

## The Potter's Art—Its History and Progress.

**C.** F. BINNS, of the Royal Worcester Porcelain Co., recently gave a lecture in London, on "The Potter's Art," and went far back into prehistoric times, in order to give his audience a grasp of the extreme antiquity of fictile productions. Mr. Binns showed by pictures from Egyptian, Assyrian and Greek pottery, that in very remote times the potter's art was not only a thriving, but an honored one. The discovery of the wheel had already taken place, and good methods of firing were evidently known. The lecturer did full justice to the progress made by the ancients with pottery, but had to give the Chinese credit for inventing porcelain and keeping their secret successfully until comparatively modern times.

The distinction between "pottery" and "porcelain" was an important one to observe, although not very generally appreciated. Pottery included any article made of plastic clay and afterwards burnt. But "porcelain" had a narrower definition, and was really a sub-class, consisting of vitrified white clay covered with a hard transparent glaze. The "vitrification" of the clay was the distinguishing characteristic. An interesting field in the history of pottery is that which concerns the art of the old English potter, who has established a jus. celebrity for himself in the matter of homely substitutes for the "black jack" and "leathern bottel." The old Staffordshire "loving cup" with four and five handles, made of earthenware and decorated with white "slip," was, the lecturer said, peculiarly appropriate to the native inglenook, and the counties of Kent and Surrey shared in the honor of such productions. The Dutchmen with their "delft" ware imitated porcelain by coating their grosser clay with a white enamel. Some interesting lore was retailed as to the introduction of true porcelain into Europe and the accidents which led to the discovery of the genuine "kaolin" or China clay, which for centuries had been regarded as a magic production of the Celestials. The kaolin quarries of Cornwall were now



amongst the most important mineral resources of that country.

The later half of the lecturer's remarks revealed the mysteries of modern porcelain manufacture as carried on mainly in the celebrated Staffordshire potteries. First came the difficult process of grinding up the four materials—bone ash, Cornish granite, kaolin and calcined flint—into the fine impalpable cream known as "slip," and the further treatment of the creamy slip so as to produce the stiffer plastic clay used for moulding and throwing on the wheel. Of the latter processes, that of moulding was shown to abound in most complexities and difficulties. Not only has the artist to model his figure, but he has to model it in parts so skilfully arranged that the 40 or 50 different moulds required for the different parts of a single group or statuette can be readily made therefrom.

The trying processes of firing—at once the despair and the triumph of the potter—were described in an interesting fashion, and the almost endless succession of difficulties and mischances of which every piece of china has to run the gauntlet before it finally emerges were duly pointed out. It is of interest to learn that the sorter or warehouseman who examines and classifies the products of the kiln into their various grades of perfection, must be regarded as one of the most important skilled workers in the factory, for upon him largely depends the reputation of the firm, for the excellence of the goods that pass forth to the world.

**The Origin of Diamonds.**

AS usual upon disputed points, speculation has been busy about the origin of the diamond, and a large number of theories, all more or less probable, have been propounded to set the matter at rest, writes Herbert J. Gibbins in *The Gentle-*

*men's Magazine.* The two most reasonable expositions are, perhaps, the explanations put forward by M. Parrot and Baron Liebig. The former scientist, who has laboriously investigated the perplexing subject, is of the opinion that the diamond arises from the operation of violent volcanic heat on small particles of carbon contained in the rock, or on a substance comprised of a large proportion of carbon and a smaller quantity of hydrogen. By this theory, as he conceives, we are best able to account for the cracks and flaws so often noticed in the gem, and the frequent occurrence of included particles of black carbonaceous matter.

Baron Liebig, on the other hand, claims the credit of offering a simple explanation of the probable process which actually takes place in the formation of the diamond. His contention is that science can point to no process capable of accounting for the origin and production of diamonds, except the powers of decay. If we suppose decay to proceed in a liquid containing carbon and hydrogen, then a compound with still more carbon must be formed; and if the compound thus formed were itself to undergo further decay, the final result, says this eminent authority, must be the separation of carbon in a crystalline form.

**Rajahs as Mine Owners.**

SOME very fine specimens of the diamond crystal have long been found near the town of Purnaor Pannah, in Bundelcund. The mines producing them are situated in a range of hills, called Bund-Ahill by the natives, extending about 20 miles in length by between two and three in breadth, and are said to be partitioned into 21 divisions; but we do not know that the whole belonged to Bundelcund. Of these the mines of Rajepoor, Maharajepoor, Kim-

merah and Guddaseah contain the best diamonds, and one dug from the last-mentioned mine has been reputed one of the largest in the world. It was kept in the fort of Callinger, among other treasures of Rajah Himmit Bahadur.

A number of rajahs are proprietors of the mines, each having a charge of his own, without any interest in the produce of the rest. A superintendent is appointed to inspect the produce, and every diamond as soon as found is registered, valued, and, if the rajah does not choose to keep it, is offered for sale. When sold he receives two-thirds of its value. In the reign of the Emperor Ackbar, the mines of Pannah produced to the amount of £100,000 annually, and were then a considerable source of revenue; but for many years they have not been so profitable, although some diamonds of exceptional size and value are discovered occasionally in the Guddaseah mine.—*The Gentlemen's Magazine.*

**English as She is Written.**

THE following interesting communication was received by a prominent silver house a few days ago:

Dear Sir i rite th's Day of lord 1894 i Wish to act as an agences for Voor in this county to sell Silver Weard for you Please send med catloug and i will Sen in wyared at once Ocala Fla — — — riter.

It is to be said that no jeweler of that town bears the name of the "riter."

Much attention is paid to curving clasps, slides and borders. Those with ribbons drawn through them are worn around the neck.

New ring stands are a velvet pincushion cup shaped and mounted like a candlestick, the hooks for the rings hang from the outer curved border of the cushion.

WE manufacture Souvenir and Advertising Spoons in Sterling,

Aluminum and

Electro-Plate.



Also

Electro-Plated Spoons, Forks, Knives, Etc.

**NIAGARA SILVER CO.,**

**NIAGARA FALLS, N. Y.**



NEARLY A CENTURY OLD.

E. GÉRARD, DUFRAISSEIX & CO.,  
SUCCESSORS  
FABRIQUE FONDÉE EN 1797



THE  
CH. FIELD HAVILAND  
LIMOGES CHINA

IS MARKED:



NEW GLAZE COLORS  
(FURNACE FIRE),



HAVILAND & ABBOT, { O. A. CAGER & Co.  
CHAS. FIELD HAVILAND & Co.

IMPORTERS OF CHINA,

P. O. Box 505.

29 BARCLAY STREET,

NEW YORK.

AGENTS FOR

E. GÉRARD, DUFRAISSEIX & CO.,  
LIMOGES.

NEW YORK OPEN STOCK.

We carry at all times a large assortment of the "Chas. Field Haviland" china in white and decorated goods, to repack for immediate shipment or for sale in original casks. Have now sixteen *open stock* decors and are constantly adding new designs.

IMPORTATION SAMPLES.

The newest and choicest designs always to be found in our import rooms. Novel forms and tasteful decors.

New York Sample Rooms, - - No. 29 Barclay Street.

# A. A. VANTINE & Co.,

877 & 879 BROADWAY,  
NEW YORK, N. Y.



200 & 202 MADISON ST.,  
CHICAGO, ILL.

## Largest Importers

JAPAN, CHINA,  
INDIA, TURKEY, PERSIA.

High Grade Porcelain, Delicate Decorations, Odd Cups and Saucers,  
Plates, Dishes, Cracker Jars, Teapots, Chocolate Pots,  
Sugars, Creams, Vases, Lamps, Jardineres.

These Goods are Made Especially for us and Meet the Demands of the Jewelry Trade.

SEND FOR SAMPLES.



### The Other Side of Life.

A clock is dumb; but it makes itself understood with its hands.—Yonkers *Statesman*.

Fogg very appropriately calls the cord attached to his eyeglasses his spec-tackle.—Boston *Transcript*.

#### A VALUABLE ERROR.

CHOLLY—Why, wheah ah youah diamonds and watch gone?

CHAPPIE (beamingly)—Oh, I met a bunco man this mawning, and he took me foh an Englishman, just ovah, y' know; so I let the deah fellow cheat me out of ev'wything.—*Puck*.

#### WHO WOULD HAVE THOUGHT IT?

NEW CLERK IN JEWELER'S—Young lady in front wants to see some rings exactly like one she has on. She savs she thinks of having two alike, just for the fun of the thing.

JEWELER—Don't waste time on her. That ring she has is an engagement ring, and she wants to find out what it cost.—*Exchange*.

#### DOING HIS BEST.

"Hello, Threeshelle," said Bunko. "Did not know you were here. Taking in the town?"

"Well, I can't say that I'm taking in the whole town," said Threeshelle, as he deftly

extracted a gold enameled hat pin from the headgear of a lady who was passing. "But I'm not letting anything escape me."—Chicago *Record*.

Justine comes in from the market.

"Your turkey is nothing much to look at," observes her mistress.

"Just wait till I have stuffed it with truffles; it's the same as madam when she hasn't got her diamonds on."—*L'Intransigent*.

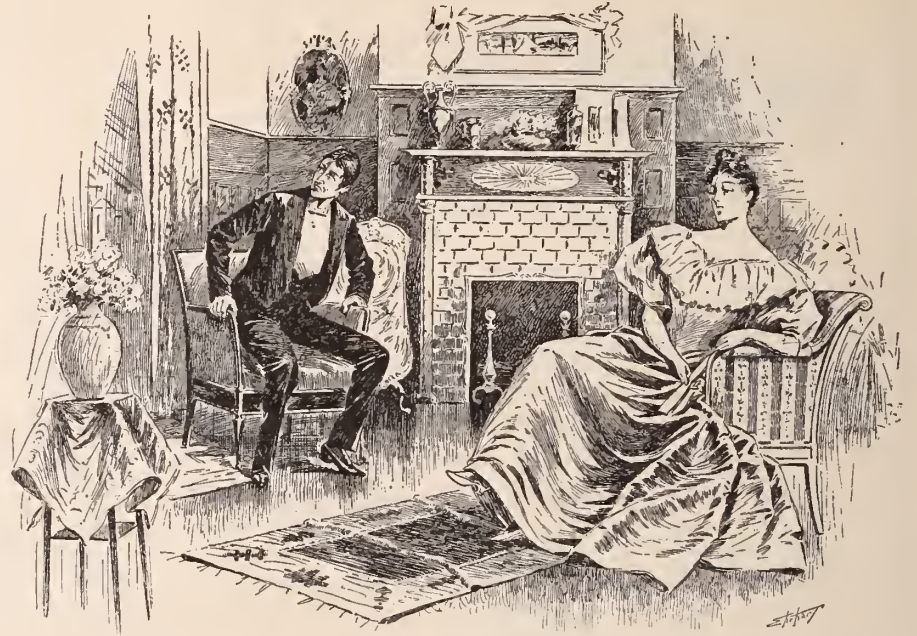

THE PERVERTED CHRONOMETER.

BERTIE VAN STAY.—Isn't that an alarm clock going off in the hall?

MAY WHEAT.—Yes.

BERTIE VAN STAY.—Who on earth in your family rises at midnight?

MAY WHEAT.—Papa does, if I haven't gone to bed then.—*Puck*.

# Chrysanthemum.

WE BEG TO ANNOUNCE THE EARLY APPEARANCE OF THE GREATEST EFFORT IN SPOONS AND FORKS, THE



# Chrysanthemum,

(DESIGN PATENT PENDING).

FOR A YEAR THE MOST EXPERT DESIGNERS AND DIE-CUTTERS HAVE BEEN ENGAGED ON THE RICHEST AND MOST EXPENSIVE SPOON AND FORK DIES EVER PRODUCED. WE BELIEVE IT WILL BE TO YOUR ADVANTAGE TO INSPECT THE

# Chrysanthemum

PATTERN BEFORE RENEWING YOUR STOCK OF SILVER.

PATTERN IS NOW IN PROCESS OF ILLUSTRATION.

WM. B. DURGIN,  
CONCORD, N. H.

WHITE'S EYE SHADE. **W. B. WHITE & SON**  
MANUFACTURERS OF  
Spectacle and Eye Glass  
CASES



90 SOUTH STREET, BOSTON.

Special Cases made to order for Optical Trade. Cases for Trial Lenses. Opera Glasses recover'd, etc. Chatelaine Spectacle Cases. World Bound Leather Cases for combs, scissors etc. Over forty kinds of cases manufactured

**SPECIAL** NOTICES  
IN  
THE JEWELERS'  
CIRCULAR  
Produce the  
results desired.

**Belts**  
AND **Buckles.**

Send for Samples.

Elegant designs. Prices as low as the lowest. Hair Pins, Link Buttons, Ladies' Combination Shirt Waist Sets and all the latest in STERLING SILVER NOVELTIES.

MANUFACTURED BY

**CODDING BROS. & HEILBORN.**

North Attleboro, Mass.

Chicago office, Buck & Hall, 103 State St., Rm. 802.  
New York office, C. A. Vanderbilt, 178 B'way



# HINRICHS & CO., BRIC-A-BRAC AND ART POTTERY.

29 AND 31 PARK PLACE,  
NEW YORK.

## SEEING



is believing, and to see the product of our Optical prescription department, will lead you to believe that your popularity as an Optician will increase if we fill your orders.

**QUEEN & CO.,**

MANUFACTURING OPTICIANS,

1010 Chestnut Street, Philadelphia.

**McINTIRE, ULMER & CO.,**

Manufacturing Opticians,

FRAMES, LENSES,

**PRESCRIPTION WORK,**

Expert Work at **LOWEST PRICES.**  
WHOLESALE ONLY.

S. E. Cor. 8th & Sansom Sts., PHILADELPHIA, PA.

Special drive in Eye Glass Hooks, \$3.25 per gross in lots not less than one-half gross. Single doz. 35 cts.

**PATENT paneled METAL**

## CEILINGS

Stamped Raised Panels.

ARTISTIC AND PERMANENT.



Easily applied in new buildings, and over old broken plaster or wood Ceilings. If interested in building or repairing, send stamp for Illustrated Catalogue, and state if **CHURCH, HALL STORE, OFFICE,** or **SCHOOL** Ceiling is wanted. Address

**A. NORTHROP & CO.,** Pittsburg, Pa.

**Headquarters**  
FOR  
**ELECTRIC & PORTABLE**  
**Watchman's Clocks**

Lowest Prices.  
Latest Improvements,  
Patente 1886-1893.  
Send for Circular.  
**E. O. HAUSBURG,**  
41 Maiden Lane, New York. **THE "ALERT."**

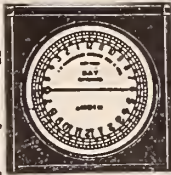

Price,  
Complete  
\$10.00

**THE PHILADELPHIA COLLEGE OF HOROLOGY**  
A Practical School for Watch-Makers.

Most complete school of horology in America, elaborate outfit of appliances. Skilled and competent instructors. Jewelry work and stone-setting taught, also engraving. Send for prospectus.

**F. W. SCHULER & CO.,**  
No 623 HEED BUILDING. PHILADELPHIA, PA.

**G.A. WEBSTER**

42 & 44 Madison St., Chicago, Ill.

**Manufacturer,**

AND WESTERN AGENT FOR

**E. G. WEBSTER & SON,** of Brooklyn, N. Y.

**A. F. TOWLE & SON CO.,** of Greenfield, Mass

**HENRY ABBOTT,**

MANUFACTURER OF

**Stem-Winding Attachments**  
**FOR WATCHES,**

**No. 2 Maiden Lane, NEW YORK.**

SPECIAL SALESMAN OF

**WATCHES, DIAMONDS,**

Bric-a-Brac

and Art Goods

FOR

**Established Jewelers.**

WRITE FOR PARTICULARS.

Communications Strictly Confidential.

References given in all parts of the United States from Retailers and Jobbers.



**S. C. JACKSON,** 180 BROADWAY, NEW YORK.  
MANUFACTURER OF

Fine \* Cases \* for \* Jewelry, \* Silverware, \* Etc.

ALSO SHOW CASE TRAYS AND FANCY HARD WOOD WORK

Samples sent on application. Estimates furnished

**"Old English"**

Coffee Spoon.

\*\*\*



DESIGN PATENTED.

**Towle Mfg. Co.,**

MANUFACTURERS OF

**STERLING SILVERWARE.**

NEWBURYPORT: No. 214 Merrimack St. CHICAGO: Nos. 149 & 151 State St.

**REMOVAL!**

**L. BLACK & CO.**  
178 BROADWAY,

WILL REMOVE IN APRIL TO THEIR FACTORY,

**DETROIT, MICHIGAN.**

**ALBERT BERGER & CO**  
47 MAIDEN LANE, N. Y.

**Spectacles & Optical Goods,**

GROUND LENSES A SPECIALTY.





**B. & W. B. SMITH,**

220 W. 29<sup>TH</sup> ST.,  
NEW YORK.

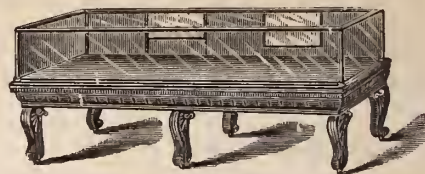

Dust Tight Wall Cases. Improved system of Shelving and Electric Wall and Counter Cases Lighting.

IMPROVED DUST TIGHT.

◁ SMALL CASES FOR SPECIALTIES ▷

ALL GLASS.

NO MOULDINGS

**S. F. MYERS & CO.,**

WHOLESALE JEWELERS,  
MYERS BUILDINGS, - - NEW YORK.

1894 ISSUE, No. 38,

**OUR ROYAL CATALOGUE**

Illustrates all that is new, unique and desirable in everything that pertains to jewelry.

Sent free to dealers who have not received it.

TWENTY-TWO DEPARTMENTS.  
SEVEN DOUBLE FLOORS.

Myers Buildings, 48-50 Maiden Lane, New York,  
33-35 Liberty St.,



**VACHERON & CONSTANTIN,**  
GENEVA, SWITZERLAND.

FINEST QUALITY OF WATCH MOVEMENTS, FITTING ALL SIZES OF AMERICAN CASES.



**EDMOND E. ROBERT,**

Agent for the United States and Canada.

21 & 23 MAIDEN LANE, NEW YORK.

FRENCH ENGLISH  
CLOCKS AND HALL CLOCKS AND  
MATERIALS. MATERIALS

**CHAS. JACQUES CLOCK CO.,** 22 CORTLANDT ST., N. Y.

**J. SCHAWEL & CO.,** 29 John St., N. Y.

GOLD & SILVER REFINERS, ASSAYERS & SWEEP SMELTERS.  
STERLING SILVER, 925/1000 FINE IN SHEET AND WIRE.  
Soft Platinum, Sheet and Wire for Manufacturing Jewelers.

**J. PRINCE,**  
Jewelry Auctioneer,  
At liberty from January 1st, 1894. Retail Jewelers only. Address,  
Rooms 9 & 10, 137 BROADWAY  
N. Y. CITY.

**WM. BIRMINGHAM & CO.,**  
MANUFACTURERS OF  
All Kinds of Leather Spectacle and Eye Glass  
**CASES,**  
728 Arch Street, PHILADELPHIA, PA.

**OPPENHEIMER BROS. & VEITH,**  
WATCHES AND



**DUEBER CASES, HAMPDEN MOVEMENTS.**  
AMSTERDAM, HOLLAND, 2 TULPSTRAAT. LONDON, ENG., 28 HOLBORN VIADUCT.  
NEW YORK, 35 MAIDEN LANE.

For **BADGES AND MEDALS**

Flag Pins, Class Pins, Class Rings  
and Special Work of all Descriptions

SEND TO **E. R. STOCKWELL,** MANUF'R.  
19 John Street, New York

**NEW CLOCK STAFF WRENCH.**



This entirely new and most useful tool is for setting up clocks, particularly fine and costly ones. Can remove pivots at ease. No chance of displacing other pivots in the operation. For description, send 5c. in stamps for catalogue of over one thousand varieties of fine tools.

O. W. BULLOCK & CO., Springfield, Mass.

If Your Sales  
Are Not Satisfactory

ADDRESS

**DE B. O. SCOTT,**  
20 Murray Street, New York.  
AUCTIONEER.

Specialties: Watches, Clocks, Bric-a-Brac, &c.

Write for particulars and references.

**IT PAYS** TO KEEP IN TOUCH WITH TRADE AFFAIRS. **For 4c. a Week will do it. Subscribe.**  
THE JEWELERS' CIRCULAR.

1869-1894=Twenty-five Years Oldest, Best Brightest, Newest, = The Jewelers' Circular.





# THE JEWELERS' CIRCULAR

AND HOROLOGICAL REVIEW

Copyright by THE JEWELERS' CIRCULAR PUB. CO.

189 Broadway, New York.

Entered at the Post Office in N. Y. as second-class matter.

VOL. XXVIII.

NEW YORK, WEDNESDAY, APRIL 18, 1894.

No. 11.

## THE DELICACY OF FRENCH SILVERWARE.

THE characteristics of French art in silversmithing are illustrated in the two prize pieces depicted on this page. The engravings are reproduced from *Les Arts du Metal*, of Paris, France, and vividly bring out the elements of the designs. The de-

the second of 500 francs to M. Lalioue. As strictly ornamental pieces, the designs of these cups are admirable, the combination of leaves, medallions and birds in the former being harmonious and poetic in feeling, while the leaf work on the stem of the latter is strikingly delicate in treatment.

ago. Still there is perceptible headway. Italy gave its adhesion to the uniform standard system recently and uses "Central Europe" time, which is an hour earlier than Greenwich time. The Minister of Public Works also required all railroad companies to print their schedules with the hours numbered up to "twenty-four," and counting from midnight to midnight.

### An Historic Ring.

Clocks in the railway stations have, there-



FIRST PRIZE, 1500 FR.

IN the possession of William B. Fry, of Drifton, N. Y., is a relic which, to him, is almost priceless. It is at once a symbol, a sign and a token—a symbol of that herald of freedom and liberty which received the ovation of a continent only a few months ago; a sign of the veneration which was felt for the liberty bell years ago, and which time has increased and strengthened and a token that will remain a precious heirloom in the family of Mr. Fry.

The relic is in the shape of a ring and was made from the metal that was cut away along the zig-zag crack of the liberty bell with the idea that it would restore the tone of the bell. Joseph Bickley, a cousin of Mrs. Aurelia S. Fry, the mother of William B. Fry, was in charge of the bell at that time. He took the chippings and had this ring constructed out of them. In the year 1850, while Mrs. Fry was on a visit to the family of Mr. Bickley, in Philadelphia, the latter presented her with the ring, and, naturally, she guarded it with jealous care until on Christmas of last year when she presented it to her son, William B. Fry.

### The Twenty-four Hour System.

SLOW progress has been made in securing the adoption of the 24-hour system of notation in time-pieces and railway timetables, since an international conference in Washington, representing twenty-five different countries, recommended it ten years



SECOND PRIZE 500 FR.

signs were submitted in a cup competition, details regarding which we have not been able to ascertain. The first prize of 1,500 francs was awarded to M. Mouchon, and

fore, been modified by the addition of an inner circle of figures, painted in red, covering the last half of the day. Although Roman numerals are used to designate the



# DEITSCH BROS.,

7 EAST 17TH ST., NEW YORK.

## LEATHER GOODS.

**EBONY AND SILVER COMBINATIONS.**

ORIGINATORS AND MAKERS OF

NOVELTIES IN LEATHER AND STERLING SILVER COMBINATIONS.



**WM. SMITH & CO.,**

Manufacturers of Gold, Silver and Roll Plate Chains and Jewelry.



Novelties in Gold and Silver Bead Necklaces and Bracelets. Also a large line of Chain Trimmings and Silver Rings.

Office: 5 and 7 Maiden Lane, New York.      Factory: 61 Peck Street, Providence, R. I.

### BIG RETURNS MADE FOR OLD GOLD AND SILVER.

Check Forwarded 24 Hours After Receipt of Consignment.

## J. RATHBONE,

GOLD AND SILVER REFINER. ASSAYER AND SWEEPSMELTER,  
Nos. 1 to 9 Matthewson St., Cor. Cove, Providence, R. I.

### "THE BEST BUTTON MADE."

THE KREMENTZ

IN GOLD

FROM

KREMENTZ & CO.

AND ALL JOBBERS.

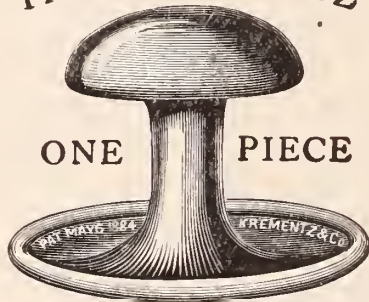

ONE PIECE

IN ROLLED PLATE

FROM

ALL JOBBERS

### COLLAR BUTTON.

IS THE ORIGINAL ONE PIECE BUTTON.

IS STILL THE BEST AND STILL UNSURPASSED.

Sold by all wholesale dealers at manufacturer's price.

**A. N. CLARK,**  
PLAINVILLE,  
CONN.

Manufacturer of the Celebrated  
**LOOP WATCH KEY.**

The Best for the Price in the World.  
CROSBY'S JEWELING TOOLS IMPROVED.

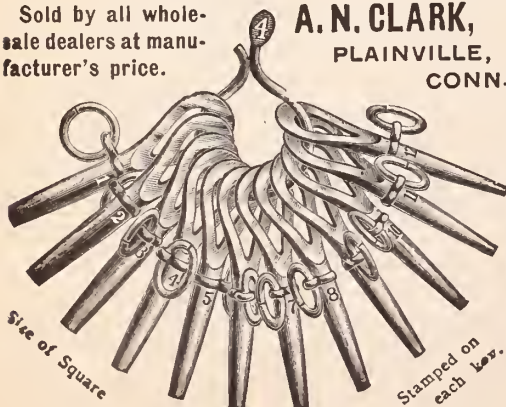

Size of Square

Stamped on each key.

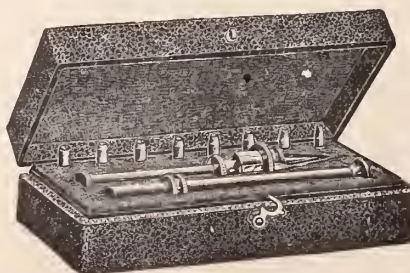

Will quote royalty or price for the manufacturing of articles of real worth.

### AMERICAN SYNDICATE OF Jewelers' Auctioneers.

ESTABLISHED for the sole purpose of conducting sales for established Jewelers in the United States, Canada and Mexico. We do not sacrifice your goods. We take no sales on a percentage. Our terms are strictly one-half the profits realized on all goods sold. We guarantee you against any loss. We pay all our own expenses; we don't ask you to pay one cent of expense on our account. We buy stocks complete as well as sell them. If your stock is small, or your assortment is not complete, we will furnish from one to ten thousand dollars worth of any kind of stock you may need and in which you need not invest one penny. Don't make any arrangements with others until you read our pamphlet which we will send you free, giving you full particulars of our style of doing business, and the liberal offers we make to Jewelers. We don't care how small your stock is, we will furnish all the stock you need to make a successful sale. We challenge the world for any fairer or more liberal propositions than we make Jewelers. Don't fail to send us your address, and we will send you our business pamphlet, which gives you full explanations as to our terms and style of doing business. Address,

### AMERICAN SYNDICATE OF JEWELERS' AUCTIONEERS.

Offices: 20 WEST 14th STREET, NEW YORK.  
611 PENN AVE., WASHINGTON, D. C.

### CAMPBELL-METCALF SILVER CO.



2 Maiden Lane, N. Y., with Holmes & Edwards Silver Co. 66 Stewart St., Prov., R. I. Mills Bldg., San Francisco, 8th Floor, Room 1.

JACOT & SON  
IMPORTERS AND MANUFACTURERS OF

BOXES 39  
Union Sq., New York.



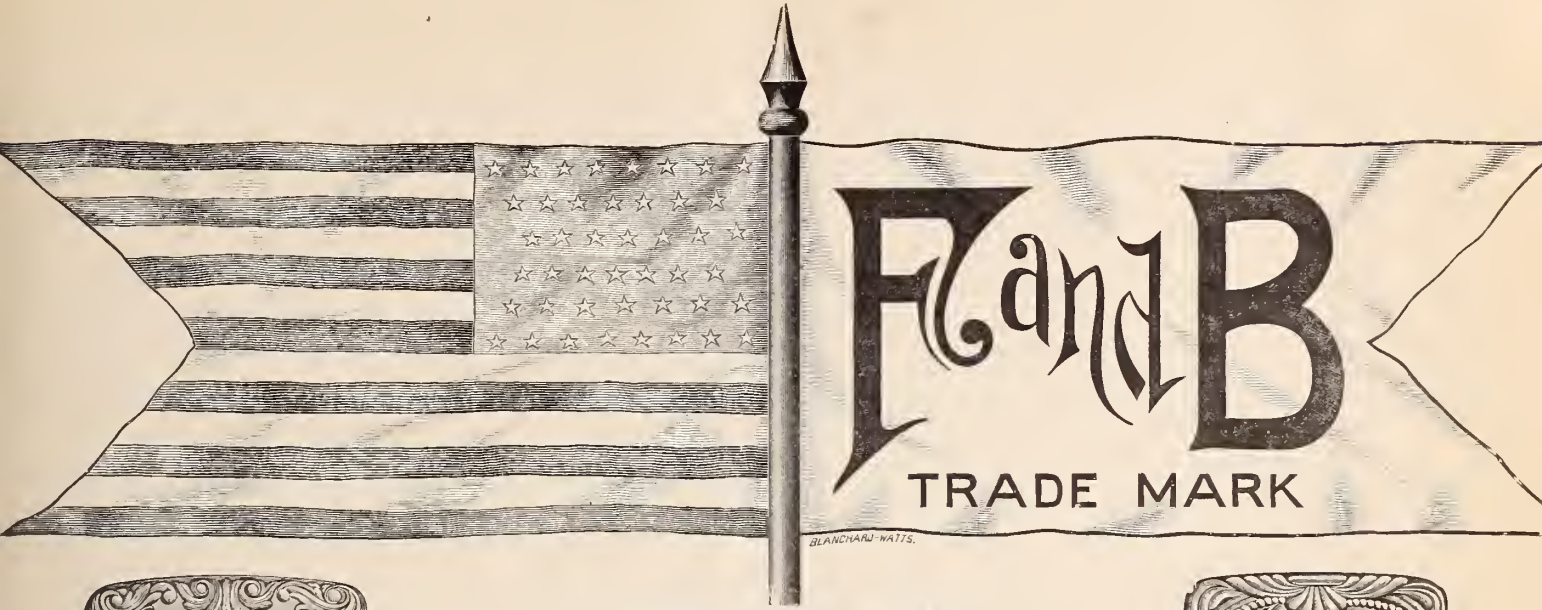

No. 1. Match Box and Cigar Cutter Combined.

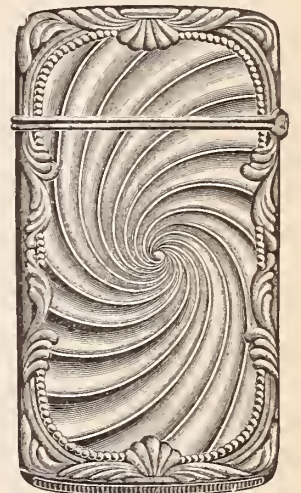

No. 2. Match Box and Cigar Cutter Combined.

**W**E ILLUSTRATE OUR NEW PATENTED MATCH BOX IN STERLING SILVER 925-1000 FINE. THERE IS A SLIDING KNIFE IN THE COVER TO CUT OFF THE END OF A CIGAR, AND WORKS PERFECT, CUTTING A CIGAR CLEAN AND JUST RIGHT. THE TIP IS THROWN OUT THROUGH AN OPENING AND DOES NOT FALL DOWN AMONG THE MATCHES. THE BEST AND MOST CONVENIENT EVER MADE FOR A SMOKER.

EVERY OUNCE OF SILVER THAT WE USE, IS 925-1000 FINE.

~~~~~

**Foster & Bailey,**  
Providence, R. I.



Front View.

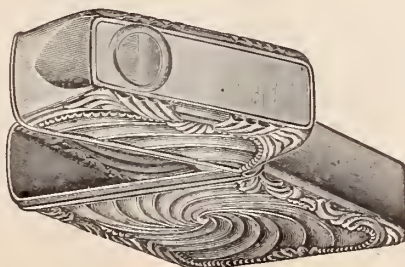

No. 2. Side View.



No. 2. Open.



hours before noon, Arabic figures are employed for the other twelve. The reason for this probably is that "18" is more compact than "XVIII," and "23" than "XXIII."

The American Society of Civil Engineers has had a Committee on Uniform Time Standards for a dozen years or so, and the latter makes annual reports on the progress of the movement. At the society's headquarters in this city there is a clock with a 24-hour face, but differing somewhat from the one just described. It has twelve openings just where the numbers are usually placed on a dial, and directly behind it is a disc, susceptible of a little rotatory motion. During the morning the figures from "1" up to "12" are displayed by that disc through the holes in the dial; then a change occurs automatically, and a fresh set, from "3" to "24" is substituted.

#### The Liabilities of J. J. Dunlap.

BRIDGEPORT, Conn., April 12.—J. J. Dunlap, the insolvent jeweler, filed a statement of his liabilities in the probate office yesterday morning. They were listed as follows: Taxes, \$65; contingent liability on a note to C. E. Messenger, of Winsted, endorsed by Elizabeth and J. J. Dunlap, \$1,300; interest on said note, \$135; John Hellman, \$35; S. T. Gate, \$25; Union Publishing Co., \$38. C. B. Gregory, M. D., \$25, and J. T. Hubbard, of Litchfield, \$30, making a total indebtedness of \$1,673.

#### Simons, Bro. & Co. Need Not Pay an Accommodation Note.

PHILADELPHIA, Pa., April 12.—The controversy over the \$5,000 accommodation note of Simons, Bro. & Co., given to Francis W. Kennedy, when president of the Spring Garden National Bank, was decided by Judge Butler in the United States Circuit Court yesterday against the receiver of the bank.

The case involved the point whether the firm must pay an accommodation note given to Kennedy for the bank, but which he used for his own purposes. By agreement of counsel, four jurors were called, and Judge Butler listened to the testimony of a number of witnesses. They were mostly former clerks in the Spring Garden Bank, and some of them were officials of other city banks. They were examined to show Kennedy's authority in the management of the affairs of his bank and his borrowing from other banks, etc.

One witness, Joseph S. Miller, who was not connected with the bank further than being a heavy depositor, gave testimony as to how he lost \$10,000 through Kennedy. Mr. Miller said that Kennedy obtained \$10,000 in notes from him upon the statement that the proceeds of them were to be applied in carrying some stock of the bank. The notes subsequently came into the possession of other banks and Miller finally had to pay them.

Samuel A. McClure, formerly assistant

cashier of the Spring Garden Bank, was called to testify that he remonstrated with President Kennedy over one of his transactions, and then went before the Board of Directors about it, and was treated by that body with contempt. The testimony, however, was excluded. When the witnesses had finished, Judge Butler delivered an opinion, which was used as a charge, and under it directed a verdict for the defendant. It was rendered at once, and under it Simons, Bro. & Co. are relieved from paying the note.

#### Henry Sonneman Expires Without Gaining Consciousness.

ALBANY, N. Y., April 13.—Henry Sonneman, the jeweler, at 46½ S. Pearl St., who was found unconscious in his store last Thursday night, as reported in last week's CIRCULAR, died at the City Hospital Monday night about 10 o'clock. He did not recover consciousness, and the hospital physicians say that he died from uræmia.

Deceased has a cousin living in Syracuse, his only living relative. Chief Willard notified him of Mr. Sonneman's condition several days ago, and the cousin sent word that he could not afford to aid him or have anything to do with him. But the man will have a respectable burial. The expenses will be paid from his own money and valuables which are in the possession of Chief Willard.

# R., L. & M. Friedlander,



IMPORTERS OF  
**DIAMONDS.**

WHOLESALE  
**JEWELERS.**

JOBBER IN  
**American Watches.**

Tools, Materials, and Optical Goods.

Send for Catalogue.

65 & 67 Nassau Street, New York.

## OPPENHEIMER BROS. & VEITH, WATCHES AND

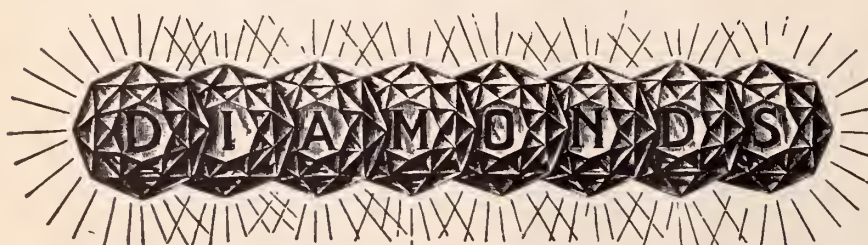

**DUEBER CASES. HAMPDEN MOVEMENTS.**  
AMSTERDAM, HOLLAND, 2 TULPSTRAAT. LONDON, ENG., 28 HOLBORN VIADUCT.  
NEW YORK, 35 MAIDEN LANE.

To insure Publication of Advertisement in current week, copy should be received not later than Monday Night.

## OLDEST PUBLICATION

Of all the Jewelry Journals.

Jewelers' Circular Publishing Co.,

189 BROADWAY, NEW YORK.

ESTABLISHED 25 YEARS.



THE  
*Pairpoint*  
 Makers and Designers of  
 "Superior" Gold  
 AND  
 Silver Plate



No 934. RING STAND, PIN CUSHION AND TRINKET TRAY COMBINED.

MFG. COMPANY,

FACTORIES:  
 New Bedford,  
 Mass.

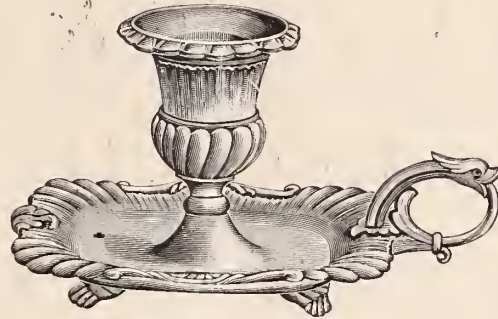

No. 6105' CANDLESTICK.

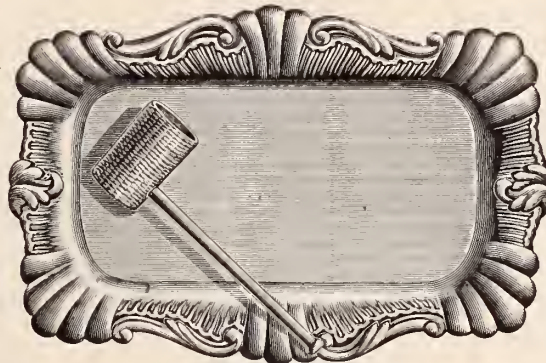

No. 1962. ASH RECEIVER.

Rich Cut Glass

AND FINE

Decorated Art Wares.

THE BEST selling goods  
 on the market bear the  
 stamp of.....

PAIRPOINT.



No. 3744. TOOTH PICK HOLDER.

A. J. LOGAN,  
 MANUFACTURER OF  
 WATCH TOOLS, HAIR SPRINGS AND  
 WATCH MATERIALS.  
 < New Catalogue just issued, Sent on Application. >  
 WALTHAM. MASS.

CROUCH & FITZGERALD.  
 Jewelry Trunks  
 and Cases,  
 161  
 Broadway,  
 Bet. Cortlandt and  
 Liberty Sts.,  
 688 B'way,  
 701 6th Ave.,  
 NEW YORK.



PATENTS SECURED WITHOUT  
 FAIL OR DELAY.  
 Send Rough Sketch or Model and I will tell you  
 whether you can obtain a patent,  
 WITHOUT CHARGE.  
 Fifteen years' experience. Ample references. Address  
 C. T. BELT,  
 WARDER BUILDING WASHINGTON D. C.

2 MEDALS AWARDED  
 Wm. K. POTTER,  
 TORTOISE SHELL WORKS PROV. R. I.  
 AT  
 WORLD'S  
 FAIR,  
 1893.



Providence Shell Works, Providence, R. I.  
 Correspondence Invited.

We sell to the legitimate Jewelry and Stationery  
 trade only.



CHOICE PAPERS

MAKERS OF

FINE STATIONERY

For Correspondence, Wedding and Business Use, handsomely  
 boxed, specially suited to the Jewelry Trade.

18 MURRAY STREET, NEW YORK.



# R. WALLACE & SONS MFG. CO.

SILVERSMITHS

Trade Mark.



R. W. & S.  
Sterling.

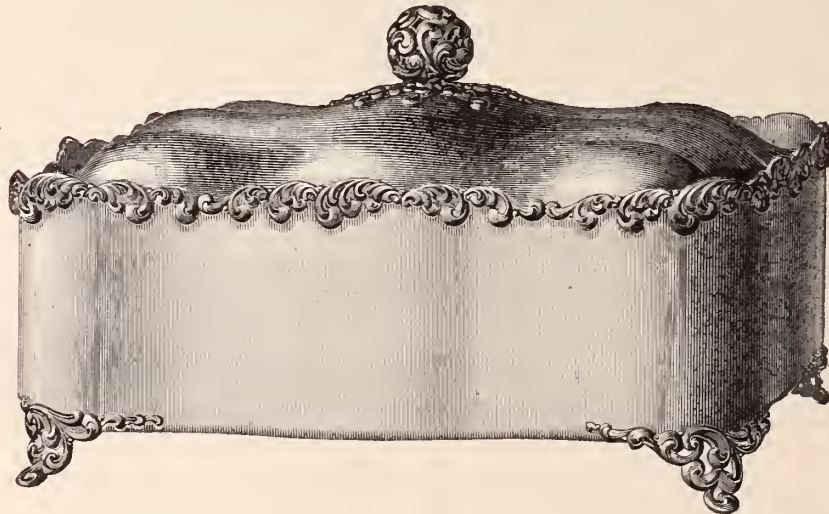

WAVERLEY SARDINE BOX.

Manufactories and  
Man Office,

WALLINGFORD, - - CONN.

BRANCHES :

NEW YORK  
3 PARK PLACE.

SAN FRANCISCO,  
120 SUTTER STREET.

CHICAGO  
86 WABASH AVENUE.



**The Deed of Assignment of F. D. Johnson & Son Cannot Stand.**

LYNCHBURG, Va., April 11.—In the Corporation Court, Judge Diggs has rendered a decision, which if sustained by the higher courts, will result in setting aside the deed of assignment made last year by F. D. Johnson & Son.

The case was of the Meriden Britannia Co. vs. F. D. Johnson & Son, A. R. Long, trustee, etc. In his opinion Judge Diggs exonerated all the parties concerned from any fraudulent intent, but said that under his construction of the law the deed could not stand, as some of the property of the parties making it was not conveyed in the instrument. This omitted property consisted of some boom lots, two endowment insurance policies of the cash value of \$600, some cigarette stock, furniture, etc.

Mr. Long, trustee for Johnson & Son under the deed of assignment, says that the boom lots were not included because they were thought to be valueless. They sold for \$28. The life insurance policies were overlooked, as it was not customary to include property of that kind in a deed of assignment. The cigarette stock was, at the time of the assignment, collateral with one of the creditors. It has since been actually conveyed though not included in the deed. The furniture was not mentioned as it was thought that rent, which is a prior lien, would absorb all the proceeds of that. The defendants will appeal the case.

**Moses Wood Goes Over to the Great Majority.**

WORCESTER, Mass., April 11.—Moses Wood, a resident jeweler of over 50 years, has gone over to the great majority, his death occurring the 4th inst. He was born in Westminster, Oct. 10, 1811. The following February the family moved to West Boylston, where they resided for about 14 years, and then removed to Hopkinton, locating in a factory village now called Woodville. In 1837 Mr. Wood came to this town and purchased of the administrator of Charles Bellows' estate his stock in trade as a jeweler, and made that his occupation up to the time he lost his eyesight about four years ago. He was widely known as a jeweler of sterling integrity and honest in the strictest sense of the term. He leaves a widow and two children, Melvin, a jeweler in Kansas City, Mo., and a daughter, Mrs. Charles E. Boyles, of Sterling.

The funeral took place at his late residence, Saturday afternoon.

**The Kreider Jewelry Co. Organized in Denver.**

DENVER, Col., April 13.—The Kreider Jewelry Co., of this city, have incorporated to manufacture and sell jewelry, etc.

The capital stock is \$5,000 in single shares of \$1 and the incorporators are: E. T. Kreider, Mary Kreider and Daniel Kreider, all of Denver.

**THE BOWDEN SEAMLESS RING**

IS MADE ONLY BY

**J. B. BOWDEN & Co.,**

Makers of Finger Rings of every Description.

**COR. BROADWAY & JOHN STREET,  
NEW YORK.**



355 Mulberry Street.

Newark, N. J.

**WM. SCHWARZWAELDER & CO.,**

Fulton St., cor. Pearl, - NEW YORK

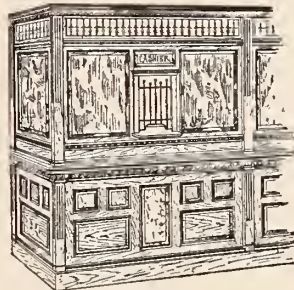

MANUFACTURERS OF

**DESKS, CHAIRS, Etc.**

Jewelers' Cases and Counters, Office Partitions, Rails, Etc.

Special Designs, Plans, Prices, etc. upon application.

**LEGENDS OF GEMS.**

By FRANK SHELLEY.

Gilt edged; bound in leather; a perfect specimen of the printer's and binder's art. Should be in every jeweler's library. Price, \$1.00. For sale by

THE JEWELERS' CIRCULAR PUB. CO.



SPECIALTY: SALES OF

**JEWELRY, BRIC-À-BRAC**

AND

ARTICLES OF VERTU

**Prices of LATHES AND CHUCKS are "WAY DOWN"**

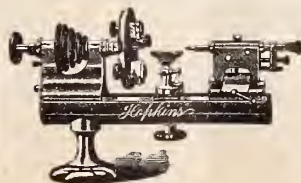

All purchasers of our THREE FOUR lathes and chuck combinations now receive FREE our new TIP OVER "T REST, on which we have patent pending. The most valuable addition to plain lathe in recent years.



SEND FOR FEB. PRICE LIST.

WALTHAM WATCH TOOL CO., SPRINGFIELD, MASS



**THOMAS W. LIND,** Manufacturer of **Jewelers' Findings,**  
67 FRIENDSHIP STREET, PROVIDENCE, R. I.



FULL SIZE NEW ROCOCO.

Call or send for samples of my New ROCOCO PATTERNS, for Picture Frames, Cane Heads, Whips, Boxes, Napkin Rings, etc.

Large Assortment of TRIMMINGS for Millinery Ornaments, Scarf Pins, etc

Roosters and other  
Animal Figures in  
Great Variety.



Write us when you  
are in need of any-  
thing.

Ballet Dancers in Five Different Positions



**Sterling Silver Match Boxes**

WITH CIGAR CLIPPER ATTACHMENT.

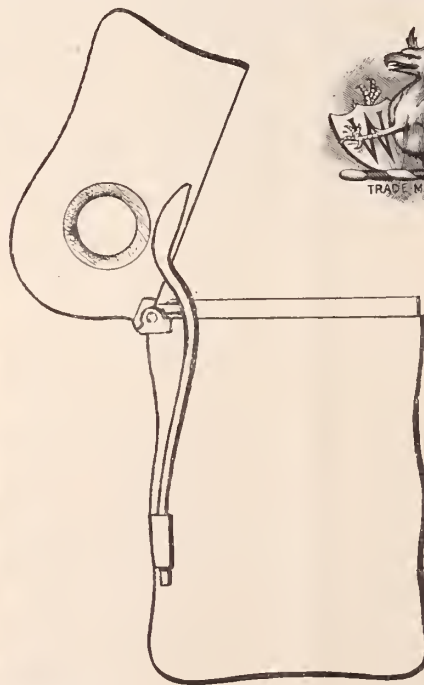
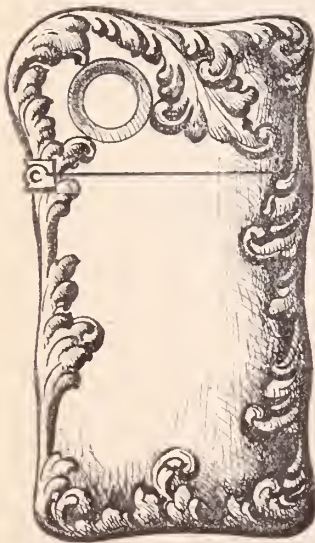

PLAIN OR FANCY.

**F. M. Whiting & Co.,** = NORTH ATTLEBORO, MASS.

Sterling Silver Hollow ware, Flatware, Novelties, Toilet Articles, &c.

NEW YORK OFFICE 857 Broadway.

AFTER MAY 1, 1128 B'way & 208 Fifth Ave.

HANDSOME NEW CATALOGUE SHOWING 22 PATTERNS IN TEAS, AND 36 PATTERNS IN COFFEE SPOONS WILL BE MAILED ON APPLICATION.

**A Gift Watch Factory Proposed for McHenry, Ill.**

McHENRY, Ill., April 12.—The meeting to discuss the watch factory project, held at the city hall a few days ago, drew out a large crowd. Mr. Hopkins, the head of the Chicago Alarm Watch Co., was present and explained what they proposed to do and what they wanted the citizens to do. He was followed by Prof. Hart, another member of the company, who explained the watch they proposed to make should they locate their plant here. These gentlemen were followed by several citizens, after which a committee was appointed to see what could be done towards raising the amount required and report at another meeting to be called at an early day.

The proposition made by the company is for a bonus of 40 acres of land and \$15,000 in cash, they would build a brick factory and employ 100 hands within one year's time.

It is believed there will be no trouble in raising the required amount necessary to secure any legitimate manufacturing institution that may desire or can be prevailed upon to locate here.

The prospectors have a patent watch that can be sold for \$1.50, it is claimed, and another for \$3. Both will keep good time and are to be placed on the market as prizes and rewards of merit. Many country newspapers are said to be willing to offer them as club premiums.

**Sudden Death of Junius P. Drake.**

ELMIRA, N. Y., April 11.—Junius P. Drake suddenly expired while sitting in the hotel lobby of the Rathbun House in this city, this afternoon. The deceased was a traveling salesman for the Rockford Watch Co., Rockford, Ill.

He came to Elmira yesterday evening from New York and stopped at the Rathbun. He complained this morning of feeling badly and stated that he was troubled with his breathing. He said he had recently recovered from a severe attack of pneumonia, and that by reason thereof, his health had been greatly shattered. The severe snow storm had struck Elmira during the night, and continued all day to-day. It was a bad day to be out, but Mr. Drake braved the storm and called upon a number of customers. It was about 3.25 o'clock in the afternoon, when suddenly he was noticed to gasp heavily and fall backwards in his seat. Several persons rushed to his assistance to find him dead. Doctors were summoned, but their services were not needed.

The deceased was a member of the Masonic Fraternity and of the Rockford Lodge of Elks. He was a member of the National

No jeweler or watch repairer should be without a copy of "WORKSHOP NOTES," a new and very useful book for the workshop. Send for circular containing a complete index of the book, and judge of its merits for yourself.



Register Co., wearing a badge No. "1714." His valuables were taken charge by Coroner Parke, who will hold an inquest to determine as to the cause of his death. An autopsy will also be performed.

Junius P. Drake is well-known in New York city, and also throughout the entire jewelry trade. He has for the past 12 to 15 years been connected with the Rockford Watch Co., of which his brother-in-law, Henry W. Price, is president. He was first salesman and then bookkeeper for the company until 1888, when he succeeded Samuel B. Mann as its New York agent. He was about 55 years old.

DEATH WAS DUE TO BRIGHT'S DISEASE.

ELMIRA, N. Y., April 14.—The remains of the late Junius P. Drake have been shipped to Delhi, N. Y., for burial. The Masonic fraternity there had charge of the burial arrangements. The autopsy performed by Drs. Maroney and Pratt, in this city, showed that the deceased had been afflicted with Bright's disease and with a disorder of the heart.

The coroner's inquest was held last night and the jury rendered a verdict that death was caused by Bright's disease.

The Effects of the Philadelphia Optical & Watch Co. Sold by the Sheriff.

PHILADELPHIA, Pa., April 13. — The sheriff's sale of the effects of the Philadelphia Optical & Watch Co. took place yesterday, and realized nearly \$70,000. Most of the stock was bought by the Keystone Watch Case Co. and Williams & Son, the latter also purchasing the fixtures and safes. Individual buyers of smaller lots were J. C. Sawyer, Boston, Mass., who bought to the extent of \$6,000; Charles Gysie, who invested \$1,500 in 117 diamond

rings; M. Sickles & Sons, S. Kind & Co., Joseph C. Gigon and Fred. Lingg.

Samuel Goodman Probably the Man Who Robbed H. C. Barnum.

SPRINGFIELD, Mass., April 14.—Samuel Goodman and Henry Facker, now under arrest in Rochester, N. Y., for the robbery of H. C. Barnum's jewelry trunk, will not return without a struggle and Goodman's lawyer has begun habeas corpus proceedings which will be heard Monday. It is expected here, however, that the proceedings will fall through, as F. A. Johnson, of the local office of the American Express Co., has positively identified Goodman as the man who shipped the case of rings to Worcester on that memorable morning. Inspector Quilty is now in Rochester with requisition papers and will bring both of the men to Springfield as soon as the habeas corpus proceedings have been decided in his favor.

In the meantime the city marshal has been working hard to tighten the chain around Goodman and has succeeded in finding all about Goodman's many aliases together with evidence of this crime.

The local police learned Goodman's real name in a very clever manner. It seems that when the city marshal was in Rochester a few days ago he searched Goodman's trunk, and found a small bottle with a label from which the name of the druggist had been torn off. Closer inspection, however, showed the name, "George H. Hartwell, druggist, Southbridge, Mass.," blown in the glass. He also found an atomizer, and discovered the figure "7," which he took to be the last figure of some prescription. With these clues he went to Southbridge and found the druggist, and the latter finally remembered compounding such a prescription last March, for a man named Daniel J. Cote, whose wife and sisters live in that

place. The marshal then looked up Cote and found that he was of French descent, and was born in 1866. Parker accompanied him on his last visit to Southbridge and left with him a few weeks ago. Cote is known as G. H. Boyd, J. G. Kirg, J. Goodnow, G. Manning and Samuel Goodman.

The Death of Henry M. Robinson.

Henry M. Robinson, a former partner in the firm of J. H. Johnston & Co., New York, died at his home 225 Rodney St., Brooklyn, Tuesday, April 10th from progressive apoplexy. Mr. Robinson was born in Montgomery, Orange County, New York, in 1837, and in 1854 went to New York city. Four years later he entered the employ of Geo. H. Jackson & Co., jewelers, 150 Bowery, in which J. H. Johnston was a partner. Mr. Johnston succeeded to the business after Mr. Jackson's death in 1860 and two years later admitted Mr. Robinson as a partner, the firm becoming J. H. Johnston & Co.

The partnership dissolved in 1870 and Mr. Robinson once more took a position in the employ of the firm, and remained until 1877. For the past two years he was connected with Jacob Morch & Sons, 130 Broadway, Brooklyn, E. D. The funeral took place from his late residence, Thursday afternoon, and he was buried at Middletown, N. Y., Friday.

Sidney Aloe, of the A. S. Aloe Co., St. Louis, Mo., has departed on an extended tour of six months through Europe and South America. He has succeeded to the position of the late A. S. Aloe, as foreign buyer.

The partnership lately existing between Geo. P. Hoerner and Otto Henerlau, under the name of Hoerner & Henerlau, Newark, N. J., has been dissolved, the former retiring. The business will be continued by Otto Henerlau, who assumes all debts.

# Sterling Silver Belts.

NO. 144.

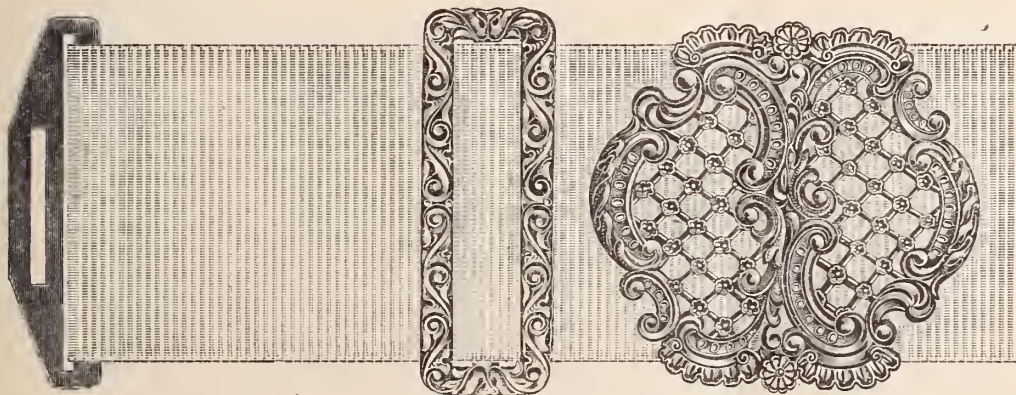

John W. Reddall & Co.,

107 HAMILTON STREET, = = NEWARK, N. J.

OURS is largely a fourteen karat gold stock, so that any Silver Specialty we may turn our attention to, receives better treatment than if we were making Silver Goods exclusively. Such applies to our line of Sterling Silver Belts, borne out by their Superiority of Make, Substantial WEIGHT, Artistic Conception, and LOW PRICES.



**Census Statistics on the Jewelry Industry for the Year 1890.**

WASHINGTON, D. C., April 14.—William M. Steuart, in charge of the Division of Manufactures of the Census, has just completed the manufacturing statistics for 67 of the principal industries in the United States, each of which report a product valued at \$30,000,000, or over, during the census year ending May 31, 1890. These sta-

Co., The Jewelers' Circular Pub. Co., Stanley Bros., Carter, Sloan & Co., Geo. W. Yates, Jr., Geo. W. Yates, Sr., T. E. Carpenter, Jos. Fahys & Co., C. L. Hurd, Providence Clock Co., Derby Silver Co., Ladd Watch Case Co., Geo. W. Grant & Co., Flint, Blood & Co., Geo. F. Fuller, J. B. Bowden & Co., Enos Richardson & Co., New York Standard Watch Co., Alfred H. Smith & Co., W. E. Webster & Co.,

that remained after the rings and charms had been taken out of the moulds. These scraps are usually melted and rolled into new plates to be used in the various processes of manufacture. Ackerman secreted these waste pieces until he accumulated a considerable quantity. He then sent them to New York for as say and sale. Sinnock & Sherrill bring this suit against Charles S. Platt to recover the value of gold he bought

STATES AND TERRITORIES.	Number of establishments reporting.	Capital.	Miscellaneous expenses.	AVERAGE NUMBER OF EMPLOYES AND TOTAL WAGES.		Cost of materials used.	Value of products, including receipts from custom work and repairing.
				Employees.	Wages.		
The United States.....	783	22,246,508	1,493,545	15,761	10,270,393	16,110,219	34,761,458
California.....	43	435,928	24,997	285	256,869	1,097,871	1,523,971
Colorado.....	4	86,075	9,030	29	29,555	49,912	110,400
District of Columbia.....	9	45,338	3,582	52	27,512	22,580	69,700
Florida.....	4	9,000	980	18	11,928	10,381	20,100
Illinois.....	25	297,615	50,978	371	298,113	453,607	932,000
Iowa.....	3	3,750	552	10	9,100	11,620	21,807
Kentucky.....	4	30,535	2,402	35	19,308	33,451	64,183
Louisiana.....	3	53,540	3,025	20	18,520	8,042	42,000
Maryland.....	8	249,335	7,445	77	53,385	133,658	260,650
Massachusetts.....	106	4,276,610	405,520	3,797	2,160,950	1,803,444	5,507,415
Michigan.....	3	3,900	1,158	25	18,528	12,186	43,575
Missouri.....	13	170,950	21,449	209	158,104	186,048	447,540
Montana.....	3	6,340	3,458	12	15,500	18,810	43,798
Nebraska.....	6	11,725	12,434	45	55,630	34,320	137,500
New Jersey.....	74	3,303,615	173,407	2,006	1,417,423	2,357,326	4,724,500
New York.....	195	3,461,294	246,216	2,420	1,929,029	3,489,132	7,385,139
Ohio.....	23	1,242,145	44,970	474	293,892	959,901	1,588,777
Oregon.....	4	59,600	5,130	32	33,094	41,400	92,654
Pennsylvania.....	45	2,160,517	115,808	1,096	663,580	1,886,311	3,215,614
Rhode Island.....	179	6,095,971	337,451	4,551	2,957,158	3,301,814	8,011,067
South Dakota.....	3	2,935	2,578	10	11,240	8,370	27,397
Texas.....	6	40,400	9,700	29	25,582	20,005	99,100
Washington.....	3	8,950	1,171	12	13,440	8,600	32,800
Wisconsin.....	4	70,950	2,942	36	23,174	47,180	94,500
All other states (a).....	13	119,490	7,191	110	68,813	112,250	253,271

a Includes establishments distributed as follows: Arkansas, 2; Connecticut, 2; Georgia, 1; Indiana, 2; Kansas, 1; Minnesota, 1; North Carolina, 1; Tennessee, 2; Wyoming, 1.

**COMPARATIVE STATEMENT FOR 1880 AND 1890.**

	YEAR.						
Jewelry.....	1880	739	11,431,164	12,697	6,441,688	10,324,990	22,201,621
	1890	783	22,246,508	15,761	10,270,393	16,110,219	34,761,458

istics are shown by totals for each State and Territory in which three or more establishments were reported. In order to avoid disclosing the operations of individual establishments, States in which there are less than three establishments are grouped together as "All other States."

The jewelry industry is one of the 67 interests represented in these calculations. The statistics are as above:

**The Filing of the Schedules of John B. Yates.**

The schedules of John B. Yates, jobber in watches, 21 Maiden Lane, New York, which were filed Friday morning, show his liabilities to be \$58,935.99 and his assets, nominal value, \$19,717.39, actually worth \$18,906.84. The value of the stock is put nominally at \$10,693.82, and actually at \$9,827.77.

Among the creditors are: Crescent Watch Case Co., Henry Ginnel & Co., N. H. White & Co., Seth Thomas Clock Co., Robbins & Appleton, Bates & Bacon, Brooklyn Watch Case Co., Fourth National Bank, Courvoisier-Wilcox Mfg. Co., Roy Watch Case

Bugbee & Niles, Bardsley Bros., Gorham Mfg. Co., Holden & Knox, Keystone Watch Case Co., Marsh & Bigney, Trenton Watch Co., and P. B. Jennings.

Judge Bischoff fixed the assignee's bond at \$18,000.

**Superintendent Ackerman's Stealings Brought to Light After 17 Years.**

A motion argued before Judge Barrett in the Supreme Court Thursday on the suit brought by Sinnock & Sherrill, manufacturing jewelers, 21 Maiden Lane, New York, against Chas. S. Platt, refiner and assayer, 31 Gold St., New York, brought to light a sensational story of theft, the plaintiffs having been systematically robbed for a long number of years by a trusted employe. In an affidavit filed in this suit, Sinnock & Sherrill state that they discharged David G. Ackerman, superintendent of their New-ark factory, on March 13th, because they had obtained proof that he had been swindling them for about 17 years.

Ackerman's method had been to collect a large portion of the gold filings and dust

from Ackerman.

Ackerman sent the gold to New York and sold it as coming from H. B. Acker, of Paterson, N. J. Mrs. Clara Van Ness transacted this part of the work for him, going to Mr. Platt's office usually and collecting the money from him. Ackerman admitted to his employers, when confronted with the proof they had obtained, that his pilferings had extended over almost the entire period of his employment.

Mr. Platt, whose firm has been dealing with Acker since 1877, had no reason to suspect that he was buying stolen goods. While the jewelers have no adequate knowledge of the amount of their losses through Ackerman, they believe that he took, as a usual thing, gold of the value of upward of \$100 a month. They sue Mr. Platt on the ground that he never obtained valid title to the property, and, Thursday, asked for an order allowing them to inspect his books, as it is only by an inspection of the books that they will be able to learn the exact amount of their loss. Judge Barrett ordered that, instead of an inspection, the defendant furnish to the plaintiffs sworn copies of every



entry in his books relating to his transactions with "Acker."

Mr. Sherrill, who was seen Friday at his office, 21 Maiden Lane, stated to a CIRCULAR reporter that Ackerman had had entire charge of their factory, and had enjoyed the fullest confidence of the firm, they never having had reason to suspect him before the discovery of his thefts. How this discovery was accomplished, Mr. Sherrill did not say. The gold stolen, he said, was taken from the sweeps, filings and odds and ends, but in such small quantities at a time that they was not missed. These were then melted into "buttons" and sold. He admitted that Mr. Ackerman had confessed everything, but whether they would prosecute him or not, he would not say.

**Failure of the Manhattan Watch & Jewelry Co.**

NEW HAVEN, Conn., April 17.—The Manhattan Watch & Jewelry Co., with offices in the Hoadley building, this city, filed a voluntary assignment yesterday afternoon in the Probate Court through their attorney, J. P. Goodhart. The liabilities are about \$10,000, and the assets one half of that sum.

Max Schwartz is the president, and M. Schwed, son of the late jeweler Marcus Schwed, deceased, is secretary.

In our next issue will be shown some excellent things in battle-axes and battle-axe heads, from the shop of T. W. Lind, Providence, R. I. Be on the lookout for them.

# REMOVAL OF American Morocco Case Co. TO 38 E. 19th ST., N. Y.

OUR SPECIALTIES  
will continue to be

Fine Silverware Cases covered with Silks, Leather and other fabrics.

Fine Cases for Jewelry and Watches.

Fine Hard Wood Trunks with one or more drawers.

Show Case Trays in all grades.



# PATENTED LEVER BACK INTERCHANGEABLE PRINCESS DIAMOND INITIAL RINGS.

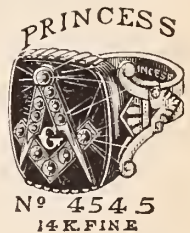

Quality, Weight and Style Unsurpassed.



### Death of Emil C. Hammer.

BOSTON, Mass., April 16.—Emil C. Hammer, treasurer and principal stockholder of the United States Watch Co., Waltham, Mass., died suddenly of heart failure on the afternoon of Thursday last in the railway station at Branford, Conn., where he was about to board the train for this city.

Mr. Hammer had recently passed his 70th year. He was born in Copenhagen, Denmark, and came to this country soon after attaining his majority. Early in life he became interested in manufacturing, and was treasurer for many years of the Walworth Mfg. Co., of this city, one of the largest producers of steam and gas fittings in the country. He was also one of the founders of the Branford Malleable Iron Works. He was treasurer of the latter concern as well as of the watch establishment, also a prominent director in the Walworth Co. at the time of his death.

Of the United States Watch Co., Mr. Hammer was one of the originators and had been its financial backer from the start. Most of the capital necessary to establish the industry and build it up through the intervening years to the present time has been furnished by him and he gave much of his time and energy to the enterprise. Prior to the business depression of last year active preparations were made by him for yet more vigorous competition with the company's powerful

rival in the watch city, a Boston office being established and a number of experienced traveling men placed on the road. This necessitated additional outlay, but he had



THE LATE EMIL C. HAMMER.

faith in the ultimate success of the venture and that faith was of the sort that generally removes in the long run all mountains of difficulty.

In Waltham, as the promoter of one of its prominent industries, he was highly esteemed for his sterling worth and kindly disposition as an employer. In Boston, where his business interests were still more important and varied, for he was a director in some of its solid banking houses, a real estate owner and representative manufacturer and had been for 30 years the Danish consul at this port, he was widely known and possessed the confidence of all with whom he had business or social relations.

Mr. Hammer's inherited traits and early education in his native city, made him not only energetic in business, but a gentleman of broad culture. He was a devoted patron of art, and his private gallery of paintings was one of the finest in Boston. He was a member of the Boston Art Club and a well known visitor at the Art Museum. His own work with the brush was excellent. His travels had been extensive and his intellectual attainments were of a high character. He was a well-read man, one of the subjects which had a special attraction for him being the legends of the Norsemen and their discoveries, particularly as they pertained to their early voyages to this continent before its discovery by Columbus.

Deceased leaves a widow and stepdaughter. The family made their home at the Hotel Alexandra, one of the estates owned by Mr. Hammer, corner of Washington St. and Massachusetts Ave. Mr. Hammer's brother, who was intimately associated with him in business, lives in Branford. The funeral took place to-day, and was largely attended by social and business friends of the deceased.

### The Suicide of Perkins E. Baldwin.

BOSTON, Mass., April 16.—Perkins E. Baldwin, New England agent for the Acme Silver Plate Co., 22 Bromfield St., committed suicide yesterday morning by hanging himself at his residence in the suburb known as Hyde Park. Mr. Baldwin had been a prominent dealer in silverware many years in Boston. He was formerly associated with his brother, C. W. Baldwin, now of Chicago, in an extensive business establishment running from Bedford St. through to Avon St. The house had a large retail trade and Mr. Baldwin was personally known to thousands of shoppers.

Deceased was born in Orange, Vt., April 26, 1842. He came to Boston early in life, had resided in Hyde Park about eight years and was highly regarded in that community as well as in Boston business circles. Worry over dulness of business is supposed to have had such a depressing effect upon him, as to produce temporary aberration. His family had noticed such a tendency during the past week. Mr. Baldwin leaves a widow and three daughters.

The L. Bauman Jewelry Co., St. Louis, Mo., have reduced their capital stock from \$250,000 to \$160,000. The assets are given at \$351,536.30 and liabilities at \$98,972.13.

## ANNOUNCEMENT.

Beginning with May 1st, '94, our New York Office will be discontinued and all communications received and business transacted in our Factory office.

**BIPPART & CO.,**

Newark, N. J.

Cor. Marshall & Halsey Sts.

**SWELL AND EYE WIRE SELLS. WE PROTECT THE SWELL BY U. S. PATENT. The Swell also protects the retailer by NOT BREAKING. All our gold frames are BUILT THAT WAY. Look you into our A. B. SEE method of teaching OPTIX. First TUESDAY each month.**



**MAIDEN LANE 15 CO. MFG. OPTICAL SPENCER.**



# The Jewelers' Circular

AND  
HOROLOGICAL REVIEW.

PUBLISHED EVERY WEDNESDAY BY

THE JEWELERS' CIRCULAR PUB'G CO.,

189 BROADWAY, NEW YORK CITY.

A JOURNAL DEVOTED TO THE INTERESTS OF JEWELERS, WATCHMAKERS, SILVERSMITHS, ELECTRO-PLATE MANUFACTURERS, AND ALL ENGAGED IN KINDRED BRANCHES OF INDUSTRY.

Our Editorial columns will contain our own opinions only, and we shall present in other columns only what we consider of interest or value to our readers. Advertising matter will not be printed as news.

Advertising rates in THE CIRCULAR are lower, considering the number of tradesmen reached by its large circulation, than in any other jewelry journal.

Notices of changes in standing advertisements must be received one week in advance; new matter can be received up to Monday.

## INFORMATION FOR SUBSCRIBERS.

### Terms of Subscription, Postage Prepaid.

	PER ANNUM
United States and Canada, . . .	\$2.00
Foreign Countries in Postal Union, - -	4.00
Single Copies, - . . . .	.10

New subscribers can commence at any time.

Payments for THE CIRCULAR, when sent by mail, should be made in a Post-Office Money Order, Bank Check or Draft, or an Express Money Order or Registered Letter. All postmasters are required to register letters whenever requested to do so.

Pay money only to authorized collectors having proper credentials.

Returning your paper will not enable us to discontinue it, as we cannot find your name on our books unless your address is given.

In changing address always give the old as well as new one. Your name cannot be found on our books unless this is done.

We will continue to send papers until there is a specific order to stop, in connection with which all arrearages must be paid; but such an order can be given at any time, to take effect at the expiration of the subscription. All such orders will be promptly acknowledged by mail.

The Courts have decided that all subscribers to journals are responsible until arrearages are paid in full and an order to discontinue has been received by the publisher.

Member of the American Trade Press Association.

Vol. XXVIII. April 18, 1894. No. 11.

### The Stamping of Silver Plate.

THE discussion now going forward in Providence, regarding the adoption of legislation to regulate the stamping of silverware will, we hope, have a far-reaching effect in arousing all the different States to action in the correction of a pervading abuse. The deceptive marking of goods finds no more pliant field than that offered in the manufacture of silver plate as is evidenced by the country being flooded with both flat and hollow ware through the medium of auction houses, racket stores and bazars, that is almost if not entirely worthless, all manner of devices being resorted to to convey an impression that the goods possess qualities that they do not. Such words as sterling, silver and plate are promiscuously juggled and stamped on the goods, often composing phrases that are ridiculous to the thinking mind, but possessing of resonance and the significance of artistic achievement to the "yap" and to the ordinary ignorant layman. The result of such prac-

tices is destructive to large manufacturing interests as well as to the interest of buyers of this class of goods. We call upon reputable merchants to refuse to handle such meretricious product, for in them resides the power to remedy the evil. The best quality of electro silver plated ware is one of the cheapest adjuncts of household equipment, both as articles of use and of ornament, and the inferior product is dear at any price. Jewelers should endeavor to unceasingly impress this truth upon the minds of the public to whom they cater, and urge them to insist upon having the name or mark of a reputable manufacturing firm upon the goods they seek to purchase.

### Jewelry Trade Statistics.

THE Division of Manufactures of the Census has just issued its report for 1890, and thus affords opportunity for interesting comparisons and deductions. The table of statistics relating to the jewelry trade is reproduced on another page of this issue of THE CIRCULAR. In 1890, 783 establishments reported against 739 in 1880; in 1890, the capital invested was \$22,246,508, to \$11,431,164 in 1880, or the average of \$28,539 to \$16,674 per firm; the number of employes in 1890 was 15,761 against 12,697 in 1890, or the average of 20 to 17 persons to each firm; the wages in 1890 aggregated \$10,270,393 to \$6,441,688 in 1880, or the average of \$13,116 to \$8,717 to each establishment, and \$651 to \$507 to each person; the cost of materials in 1890 was \$16,110,219 to \$10,324,990 in 1880, or \$20,575 to \$13,972 to each establishment; while the value of products, including receipts from custom work and repairing was in 1890, \$34,761,458 to \$22,201,621 in 1880, or the average of \$44,395 to \$30,042 to each firm. There are several large manufacturing firms that enormously developed during the decade between 1880 and 1890, and as they may be included in the number reported, a positive deduction from the foregoing figures is scarcely possible. However, we may superficially conclude that the capital employed in the jewelry industry in 1890 was over 71 per cent. more than in 1880; that more persons were employed in the industry in 1890 than in 1880, by almost 24 per cent., and that they received in 1890 over 28 per cent. more wages than in 1880. Here the remarkable increases cease for we learn from simple calculation that the percentage of increase of the materials used in 1890 over 1880, is just equal to the percentage of increase in the values of products, both being approximately 47 per cent. From these deductions it may be further deduced that 1890 was a healthy and prosperous year for both employer and employe in the jewelry industry.

Benjamin Bros., jewelers and pawnbrokers, Minneapolis, Minn., assigned Monday. The firm consists of Nathan and Charles Benjamin. The firm was formerly Benjamin & Co., Jos. G. Pavian being a partner.

## The Week in Brief.

CENSUS statistics of the jewelry industry for 1890 were issued by the Division of Manufactures of the Census—The schedules of John B. Yates, New York, were filed—David G. Ackerman, superintendent in the factory of Sinnock & Sherrill, Newark, N. J., was arrested—A settlement was effected in the affairs of F. J. Essig, Chicago—The store of D. W. Neff, Royal Center, Ind., was burglarized—A patent suit was entered against the Herman Keck Mfg. Co., Cincinnati, O.—The death occurred of Emil C. Hammer, treasurer of the United States Watch Co.—The effects of the Philadelphia Optical & Watch Co. were sold by the sheriff—The H. M. Betz Watch & Jewelry Co., Philadelphia, Pa., were sold out—Ma Myerheim, Jacksonville, Fla., assigned—The death occurred of Henry L. Perrett, an old time watchmaker of Philadelphia, Pa.—Herman T. Wolf, Philadelphia, Pa., assigned—A. T. Fritz, Philadelphia, Pa., assigned—Junius P. Drake, agent of the Rockford Watch Co., died suddenly in Elmira, N. Y.—The offer in composition of James R. Feeley, Providence, R. I., was accepted—The assignee of M. L. Read & Co., Providence, R. I., completed his inventory—The sudden death of Charles H. Peck, Providence, R. I., occurred. Perkins E. Baldwin, eastern agent for the Acme Silver Plate Co., Boston, Mass., committed suicide—The L. Bauman Jewelry Co., St. Louis, Mo., reduced their capital stock—Julius A. Lebkuecher, of Kremenz & Co., was elected Mayor of Newark, N. J.—Spott & Spott, Richmond, Va., confessed judgment—Benjamin Bros., Minneapolis, Minn., assigned—Chicago wholesalers will close early on Saturdays—Alfred Selman, New York, was discovered in his room in a precarious condition through a pistol wound.

### J. A. Lebkuecher Elected Mayor of Newark by a Handsome Plurality.

NEWARK, N. J., April 11.—For the first time in 10 years Newark has elected a Republican Mayor. Julius A. Lebkuecher, of Kremenz & Co., an account of whose candidacy and a sketch of whose career have previously appeared in THE CIRCULAR, was yesterday elected this city's chief magistrate, by a plurality of 4,577. Since the result was known Mr. Lebkuecher has been the recipient of numerous congratulatory letters and telegrams, the latter averaging about 50 per day.

It is safe to say that the names of nearly all the jewelry firms in Newark, as well as those of all the firm's customers, appear among these messages of congratulation. Mr. Lebkuecher takes his seat May 7th, for a term of two years. His election will not interfere with the business of Kremenz & Co., as he will continue to keep an active interest in that firm.

A. F. Flint, Savannah, Ga., has been closed out on a mortgage for \$1,700.



### New York Notes.

C. W. Hutchinson has entered a judgment for \$542.20 against Stites Bros.

Ludwig Nissen & Co. have filed a judgment for \$370.15 against Edw. Clarke.

A judgment for \$599.98 has been filed by H. Levy against Moses J. Lichtenberg.

Chas. H. Peckham, 169 Broadway, will go to Boston and New England next week.

Camerden & Forster have entered a judgment for \$112.99 against Howard M. Durant.

A judgment for \$501.92 has been entered against Simon Dessau, by the Mechanics' & Traders' Bank.

The American Morocco Case Co. removed Saturday from the quarters they have occupied for 15 years at 9 Bond St., to 38 E. 10th St.

The New York office of the Ladd Watch Case Co., formerly of 11 Maiden Lane, is now in new quarters in the Stevens building, 3 Maiden Lane.

Henry May & Co., wholesale dealers in watches, diamonds and jewelry, have removed from 51 Maiden Lane to the new building at 45 Maiden Lane.

Judgments against Sarah Moschowitz were entered last week by Herman Bachrach for \$901.96; by Maurice Weil for \$867.62; and by J. W. Wieman for \$288.11.

Emil Geisler, 207 E. 69th St., a jeweler, was taken to the Presbyterian Hospital last week suffering from bodily injuries and a scalp wound, the result of a runaway accident on April 10th.

R. L. & M. Friedlander, 65-67 Nassau St., have on exhibition the chronometers displayed by H. H. Heinrich, 14 John St., at the World's Fair. Mr. Heinrich received the highest award for this exhibit.

William Weist, of 169 Ave. D, who is said to be a jeweler, was held without bail in the Tombs Police Court last week for trial on a charge of feloniously assaulting James Caratta, a musician, living at 207 Elm St.

The suit of S. F. Myers & Co. against Johanna Kastman and Adolph Hess, has been set down for trial in the City Court on April 23d. The action is to recover on two promissory notes made by the defendants and discounted by M. A. Myers.

Judge Barrett, in a suit in the Supreme Court to foreclose a mortgage on property at Broadway and Clinton Place, Thursday appointed Thos. P. Wickes referee to compute the account owing by Simon Dessau to the executors of Marks Rinaldo.

James G. Power is the purchaser of Nos. 16 and 18 Maiden Lane, southwest corner of Liberty Place, 34x32.8, a five story building, which was sold a couple of weeks ago by the Diederick estate for \$178,000.

Thomas Lyon, of Union Hill, N. J., was held at Jefferson Market last week on a charge of grand larceny preferred by Elwin Maillet, the manager of an instalment watch company, who alleged that Lyon had

bought a watch which he pawned before he had completed paying for it.

The investigating committee appointed at a recent meeting of the creditors of John B. Yates, 21 Maiden Lane, expect to call another meeting about the latter part of this week. Members of the committee stated to a CIRCULAR reporter that they did not believe there was any chance of Mr. Yates' resuming business.

Chas. P. Homans, who, under the name of A. P. Lewis, recently attempted to pass a stolen check for \$1,500, with a forged indorsement, upon Hayden W. Wheeler & Co., pleaded guilty to the charge of forgery in Part I. of General Sessions, April 10th, and Recorder Smyth sentenced him to the Elmira Reformatory.

J. B. Bowden & Co., manufacturers of rings, removed last week from Broadway and John St. to more commodious quarters in the Stevens building, 3 Maiden Lane. The new offices, which are handsomely and comfortably furnished, occupy the entire second floor of the building. The removal is in conformity with the progressive policy of this house.

Wm. J. Weiss, 35 years old, was held Thursday by Justice Taintor in \$1,000 bail for examination. It is alleged that Weiss, while employed by the Fletcher Watch & Jewelry Co., 182 Broadway, last December, appropriated to his own use, a pair of diamond earrings worth \$300. At the office of the Fletcher Watch & Jewelry Co., it was stated Monday that the case had been settled.

In Part II. of the Supreme Court Circuit Friday, in the suit of S. F. Myers & Co. against Ludwig and Julia Hess, Judge Truax gave the plaintiffs a verdict for \$8,748.37. A similar judgment was obtained by default, by S. F. Myers & Co. some months ago. This was fought by the other creditors, who had the default opened. When the suit was tried again Friday the judge directed a verdict for S. F. Myers & Co. for the full amount.

A large sign on the store formerly occupied by Benj. S. Wise & Co., 861 Broadway, told the public that the Kimberly Diamond Co. would open there Tuesday, April 14th. Benj. S. Wise's name appears as manager of the new concern. A CIRCULAR reporter failed to find Mr. Wise, but was told by a young man in the store that Benj. S. Wise & Co., recently incorporated, had discontinued business and had become the Kimberly Diamond Co.

The sheriff Thursday received an execution on judgment for \$120.81 entered against Albert B. Kapp in favor of H. Wexel & Co. The office of Mr. Kapp who does business under the style of the A. B. Kapp Mfg. Co., in the Cable building on Broadway was closed last week. The sheriff reports that there is nothing in the office but a few desks, and that Mr. Kapp has given a bill of sale to Bernhard Selig, of B. Selig & Co., Philadelphia, Pa.

Otto H. Jenssen, in his suit against the Van Houten Bros. Jewelry Co., Newark, has obtained from Judge Beach, of the Supreme Court, an order permitting him to serve the summons by publication. The suit which is for \$2,700, is on assigned claims of Mary L. Sayre and Wm. P. Sayre, the former having been the holder of two promissory notes aggregating \$2,500. The latter's claim was for \$200, due for services as salesman. In this suit an attachment was issued against the defendants March 31st, on the ground that they were a foreign corporation.

The demurrers made by the E. Howard Watch & Clock Co., the Bay State Watch Case Co. and Jas. H. Noyes to the suits brought against them in the United States Circuit Court by the Dueber Watch Case Mfg. Co., were sustained by Judge Coxe Wednesday. This suit which is for \$150,000, is brought against the various manufacturers of movements and cases under the Sherman Anti-Trust Law of 1890. Judge Coxe has decided that the plaintiffs have no cause of action. The plaintiffs will therefore appeal from this decision to the United States Supreme Court. A similar action brought under the common law for \$500,000 and involving the same parties is in progress in the New York Supreme Court.

The summary of the games rolled at the Jewelers' Individual Bowling Tournament is as follows:

	Won	Lost	Average.
1 Prize—Shiman.....	18	4	172 $\frac{2}{3}$
2 " Roll .....	17	5	170 $\frac{1}{2}$
3 " Ruefer .....	14	8	157 $\frac{1}{8}$
Woodward .....	14	8	165
Hovet .....	12	10	159 $\frac{1}{2}$
Woodland .....	11	11	153 $\frac{1}{4}$
Townley .....	10	12	150 $\frac{3}{8}$
Thornbury .....	9	13	138 $\frac{2}{3}$
Sacks .....	9	13	149 $\frac{1}{4}$
Thompson .....	8	14	153 $\frac{1}{8}$
Clifford .....	7	15	132 $\frac{3}{8}$
Mangold .....	5	17	130 $\frac{7}{8}$

In addition to the first prize, Mr. Shiman also won the prize for the highest average. Messrs. Ruefer and Woodward tied for third place. The tie was rolled off and won by Mr. Ruefer. The members hope to form a new and larger association in the Fall.

The match box shown on another page by F. M. Whiting & Co., No. Attleboro, Mass., will well repay inspection. It is made in both plain and fancy patterns, in sterling silver, and the cigar clipping attachment will commend itself to every smoker. The price is low and the box is a good seller.

The Chicago Alarm Watch Co. have incorporated with a capital stock of \$250,000 in single shares of \$10 for the "manufacturing and sale of and dealing in watches and timepieces, and the exploitation of patents connected therewith." The promoters are C. R. Hart, Harvey L. Hopkins and O. S. Reed.



**Alfred Selman in a Critical Condition Through a Pistol Wound.**

Alfred Selman, exporter of watches, 21 Maiden Lane, New York, was taken to the New York Hospital Monday night suffering from a pistol shot wound. It is believed that he shot himself while in his bachelor apartments in the Mendelssohn Club House, at 113 W. 40th St., Monday. He did not rise at the usual time, and at 1.30 P. M. the janitor of the building, becoming uneasy, opened the door with a pass-key and found Selman lying in bed in his night-clothes, bleeding profusely. The wound was behind the right ear. In his right hand was held a revolver, one chamber of which had been discharged. Selman was taken in an ambulance to the hospital.

At his office yesterday morning a CIRCULAR reporter was told that Mr. Selman was still alive and there was a chance of his recovery. It is not known, said THE CIRCULAR's informant, whether the shooting was intentional or accidental.

Mr. Selman, whose name was originally Alfred Seligman, was born in Frankfort, Germany, 41 years ago. When a young man he came to this country and shortly afterward was employed as a clerk with the Gorham Mfg. Co. A year later he entered the employ of Robbins & Appleton as entry clerk, and remained with this house until last year, having advanced to the head of their export department. In May 1st, 1893, Mr. Selman started in business for himself

as an exporter of watches, at 21 Maiden Lane. For many years he has been a sufferer from acute rheumatism, and had traveled all over the world in search of permanent relief. His friends believe that if the shooting was intentional, it was due to his great suffering from this disease.

Mr. Selman is known as a well educated man and a scholar. He possesses a knowledge of many languages.

**To Start a Gold and Silver Refinery in Attleboro.**

ATTLEBORO, Mass., April 16.—An extensive gold and silver refinery it is said is to be located here. Arrangements are now being made between those interested for a site. A large plant will be put in, making the new shop the largest smelting factory in this vicinity. The concern will be made up of Rhode Island and Attleboro men.

Will Burnham, jeweler, Maitland, Mo., has disappeared.

The store of D. P. Hoyle, San Diego, Cal., was burned out a few days ago. The stock and fixtures were saved. Mr. Hoyle expects to start up again in a few days.

Burglars broke into the jewelry and drug store of Vanderlinde & Summers, Maitland, Mo., a few nights ago, but contented themselves with the contents of the cash drawer.

**Last Week's Arrivals.**

*THE CIRCULAR has perfected arrangements for obtaining the names and hotel addresses of all the latest buyers visiting New York, and each day posts in its office, 189 Broadway, a bulletin which every member of the trade is cordially invited to copy.*

The following out-of-town dealers were registered in New York during the past week: Mrs. J. C. Nourse, buyer for Woodward & Lathrop, Washington, D. C.; St. Denis H.; A. Smith, buyer for Max Meyer & Bro. Co., Omaha, Neb., 27 Maiden Lane; E. T. Goodwin, Boston, Mass., Astor H.; M. King, Boston, Mass., Holland H.; J. Mandel, Chicago, Ill., Belvidere H.; L. Kaufman, Pittsburgh, Pa., Stewart H.; C. M. Dickinson, North Adams, Mass.; O. P. Dunbar, Steubenville, O., Astor H.; A. V. Polack, York, Pa., Astor H.; W. Eaves, Montreal, Que., Broadway Central H.; H. Bohm, Cincinnati, O., Hoffman H.; B. R. Allan, Richmond, Va., Broadway Central H.; A. Levi, Baltimore, Md., Astor H.; J. M. Harper, Philadelphia, Pa., Jefferson H.; D. Emery, Bradford, Pa., Imperial H.; S. C. Davis, Philadelphia, Pa., Continental H.; L. E. Kirstein, Rochester, N. Y., Imperial H.; J. C. Dunbar, Canton, O., Murray Hill H.; J. Floersheim, Chicago, Ill., Belvidere H.; J. Strauss, Buffalo, N. Y.

**L. TANNENBAUM & CO.,**

**Importers and Cutters of DIAMONDS AND PRECIOUS STONES,**

COR. MAIDEN LANE & NASSAU ST., NEW YORK.

Telephone, Long Distance, 1959 Cortlandt.

25 HATTON GARDEN, LONDON.

**RUBIES.**

2,373	1	Fine Oriental Ruby, 3 less 4-64 kt.,	\$150.00 per kt.
15,447	1	" " " 1 6-64 kt.,	100.00 "
33,348	1	" " " 1 less 1-64 kt.,	150.00 "
19,149	1	" " " 1 3/4 kt.,	50.00 "
1,126	1	Fine Carb. Ruby, 1 26-64 kt.,	100.00 "
2,321	1	" " " 2 less 1-16 kt.,	40.00 "
14,652	29	Oriental " 19 1-16 kt.,	45.00 "
A-339	86	" " " 14 16-64 kt.,	40.00 "
2,418		Small Oriental Ruby, 93 1/2 1-16 kt.,	6.00 "
20,317	7	Carb. Ruby, 7 10-64 kt.,	20.00 "

**SAPPHIRES.**

11,585	1	Sapphire, 3 less 5-64 kt.,	\$60.00 per kt.
8,367	1	Extra Fine Sapphire, 2 1-64 kt.,	100.00 "
19,580	1	" " " 5 25-64 kt.,	100.00 "
27,602	1	" " " 4 25-64 kt.,	85.00 "
16,348	1	Carb. Sapphire, 3 50-64 kt.,	20.00 "
8,449	1	" " " 3 17-64 kt.,	15.00 "
17,408	1	Fancy " 3 less 2-64 kt., red at night,	40.00 "
4,396	1	Fine Pink Sapphire, 1 10-64 kt.,	40.00 "
6,397	1	Yellow Sapphire, 37 kt.,	15.00 "
6,420	15	Carb. " 15 42-64 kt.,	6.00 "
35,123	30	Fancy " 18 1/2 less 3-64 kt.,	5.00 "
5,243	11	Yellow " 15 3/4 kt.,	2.00 "
13,319	8	Green " 8 30-64 kt.,	6.00 "
3,381	2	Yellow " 6 1-32 kt.,	12.00 "

**PEARLS.**

1,373	1	Fine Black Pearl, 16 1/2 gr.,	\$50.00 per gr.
A-1,697	1	Pearl, 20 1/4 gr.,	15.00 "

994	1	Pearl, 10 7/8 gr.,	\$11.00 per gr.
5,662	52	Pearls 99 gr.,	1.50 "
6,100	47	" 121 less 1-16 gr.,	.60 "
3,431	378	Fancy Pearls, 188 3/8 gr.,	2.00 "
5,431	509	" 277 1/4 gr.,	2.00 "

**CATSEYES.**

21,224	1	Catseye, 2 5-64 kt.,	\$8.00 per kt.
2,225	1	" 3 3/4 kt.,	12.00 "
33,222	18	" 37 3-64 kt.,	5.00 "

**STAR STONES.**

9,408	1	Star Ruby, 6 3/4 kt.,	\$50.00 per kt.
33,117	1	" " 11 1/4 kt.,	40.00 "
24,120	1	" " 3 3/4 1-64 kt.,	20.00 "
1,400	4	" " 4 38-64 kt.,	5.00 "
13,419	1	" Sapphire, 12 3/4 kt.,	20.00 "
32,399	1	" " 4 59-64 kt.,	20.00 "
4,414	21	" " 132 1/2 3-64 kt.,	5.00 "

**FANCY STONES.**

3,446	1	Green Chrysoberyl, 12 1-64 kt.,	\$10.00 per kt.
29,401	1	" " 3 5/8 less 1-32 kt.,	6.00 "
12,446	1	Brown " 16 1/4 kt.,	15.00 "
1,320	1	" " 12 36-64 kt.,	3.00 "
12,660	3	" " 4 56-64 Gold color,	6.00 "
23,314	10	Fancy Stones, 21 10-64 kt.,	3.00 "
2,303	16	" " 17 1/4 kt.,	3.00 "
3,302	46	" " 39 1/2 less 3-64 kt.,	2.00 "
2,445	80	" " 53 12-64 kt.,	5.00 "





# The DIAMOND EXCHANGE

14 MAIDEN LANE -  
New York.

**CHAS. F. WOOD & CO.,**  
IMPORTERS OF  
**DIAMONDS...**

**W. & S. Blackinton,**  
...OLD RELIABLE...  
**W. & S. B. ★ Plated Chains.**  
N. Y., 14 Maiden Lane. Factory, Attleboro, Mass.  
Have you seen our New Goods?

**C. COTTIER & SON,**  
... Importers of ...  
**DIAMONDS.**  
FANCY GEMS.

**S. LINDENBORN,**  
IMPORTER OF  
**DIAMONDS.**

**CHAS. H. PECKHAM & CO.,**  
IMPORTERS OF  
**DIAMONDS & PRECIOUS STONES.**  
MAKERS OF DIAMOND JEWELRY.  
PARIS OFFICE, 4 Rue Grenier St. Lazare.

**RUBENSTEIN BROS.**  
HEADQUARTERS FOR  
**QUICK SELLING GOODS**  
AT POPULAR PRICES.

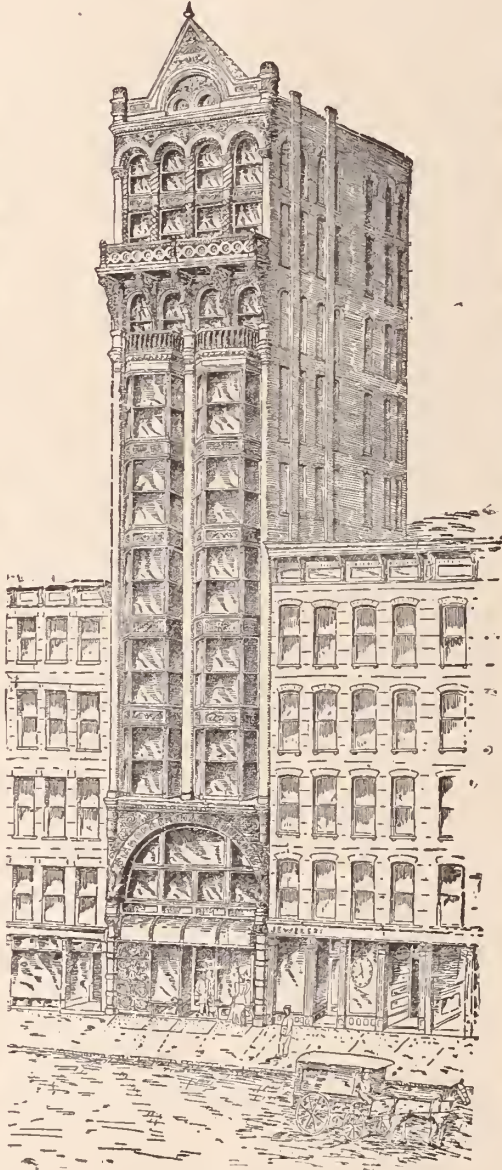

**JULIUS KING OPTICAL Co.,**  
WILL OCCUPY THE  
STORE and BASEMENT  
AFTER MAY 1st.

JOHN F. ALLEN. OSCAR T. JONASSOHN.  
**ALLEN & JONASSOHN,**  
IMPORTERS OF  
**Diamonds, Precious & Imitation Stones.**  
NEW YORK: 14 MAIDEN LANE. PROVIDENCE, R. I.: PORRANCE & PINE STS. PARIS: 46 RUE DE TURBIGO.



### Last Rites to the Memory of Hon. Samuel Simpson.

WALLINGFORD, Conn., April 11.—The funeral services of Hon. Samuel Simpson occurred at St. Paul's church at 2:30 yesterday afternoon, in the presence of a vast congregation, Rev. J. E. Wildman officiating, assisted by Rev. J. L. Scott, of this place and Rev. John Townsend, of Middletown. The officers and directors of the Wallingford National and Savings Banks and of the First National Bank of Meriden attended in a body, as did also the members of Simpson Hook and Ladder Company, the Arcanum Club, and the employes of the Simpson, Hall, Miller & Co. and the Simpson Nickel Co. shops.

Among the distinguished persons present from out-of-town were Collector John C. Byxbee, Samuel Dodd, Lewis L. Hall, George M. Curtis and Edson Sanford, of Meriden; ex-Senator Cleveland and William Morgan, of Hartford; J. R. Boice and C. F. Harwood, of Middletown; Hon. James Gallagher and others from New Haven.

The town assumed an aspect of mourning. Simpson, Hall, Miller & Co., of which Mr. Simpson was president, shut down, as did the Simpson Nickel Co., Maltby, Stevens & Curtiss Co., Metropolitan Rubber and Wire Co. The employes at the factory over which the deceased presided so many years attended the funeral in a body. A large number of the friends of the deceased were in attendance from New York and all parts of the State.

The pall bearers were Andrew Andrews, C. H. Brown, W. Hodgkinson, W. N. Mix, B. A. Treat and W. M. Whittazer. The honorary bearers were James Harrison, H. L. Hall, C. G. Pomeroy and O. I. Martin. The burial was in the family lot in the Center St. Cemetery.

At the special meeting of the National Bank it was voted to close the bank yesterday at 1 o'clock, and also voted that the officers and directors attend the funeral of Mr. Simpson in a body. Suitable resolutions were adopted. The Dime Savings Bank held a special meeting and passed suitable resolutions, and voted to have the officers and directors attend in a body. Simpson, Hall, Miller & Co.'s directors also passed appropriate resolutions on Mr. Simpson's death, as also did the Vestry of St. Paul's Church.

### THE CHICAGO JEWELERS' ASSOCIATION TO ADOPT RESOLUTIONS.

CHICAGO, Ill., April 14.—Thursday a committee of the Chicago Jewelers' Association was appointed to frame suitable resolutions on the death of Hon. Samuel Simpson, president of Simpson, Hall, Miller & Co. The following were the members of the committee: Geo. M. Wallace, R. Wallace &

Sons Mfg. Co.; A. L. Sercomb, Meriden Britannia Co.; G. J. Corey, Pairpoint Mfg. Co., and C. J. Dodgshun, Waterbury Clock Co. After an informal conference on the life and services of Mr. Simpson, Mr. Wallace was delegated to draw up the resolutions



*Samuel Simpson*

and submit them to a future meeting of the committee.

### Simon M. Jacobs, the Much-Wanted, in the Meshes of the Law.

SAN FRANCISCO, Cal., April 11.—Simon M. Jacobs, for whose capture a reward has been offered in THE CIRCULAR, and who has been living in this city during the last year under the alias of Harry Howard, is locked up in the City Prison awaiting the arrival of a detective from New York with requisition papers for the prisoner's return to New York, where he is wanted to answer a charge of embezzling diamonds from several wholesale firms.

The reward of \$500 for Jacobs' capture was offered by Ludeke & Power, 23 John St., and Schulz & Rudolph, 24 John St., from whom Jacobs obtained diamonds on memorandum and skipped. Jacobs is known as a good salesman and a fine judge of diamonds. He has been living a fast life here and patronized the race meetings and squandered large sums of money. When arrested he had about exhausted his resources. Chief Crowley has telegraphed news of the arrest to New York and has received a response that an officer would start for this city at once.

Upon receipt of the news of Jacobs' capture Detective Sergeant McNaughton left New York Wednesday with extradition papers to bring Jacobs back to that city. There are two indictments against the prisoner, which were found by the grand jury on Jan. 3d.

On Aug. 30th last, it is charged that Jacobs obtained three diamonds valued at \$500 from Schulz & Rudolph, and two diamonds worth \$300 two days later. It is also charged that Jacobs secured diamonds worth \$300 on memoranda from Stern Bros. & Co., 30 Maiden Lane, and diamonds worth \$200 from Ludeke & Power. He then disappeared. Other diamond firms are said to be among his victims.

Jacobs was extensively advertised for by the New York police and by his victims. He was traced to various cities but succeeded in escaping from the meshes of the law until last week.

### Death of a Highly Respected Jeweler.

SCRANTON, Pa., April 13.—Arthur Villwock, a jeweler doing business at Taylor, died last Saturday evening, after several months' illness. Mr. Villwock was respected by all who came in contact with him. The deceased was a member of Taylorville Lodge, No. 462, K. of P., and W. A. Connell Division, U. R., K. of P. The funeral took place Wednesday afternoon. Interment in Forest Hill Cemetery. The business places of Taylor were closed during the afternoon out of respect to Mr.

Villwock.

### The Jewelers' Security Alliance.

The regular monthly meeting of the executive committee of the Jewelers' Security Alliance was held at the Alliane office on Friday. There were present Bernard Karsch, treasurer, Messrs. White, Kroeber and Abbott, and Geo. H. Hodenpyl, secretary.

The following were admitted to membership: Boettinger & Walter, 205 W. Lexington St., Baltimore, Md.; Galt & Bro., 1107 Pennsylvania Ave., Washington, D. C.; Harris & Shafer, 1113 Pennsylvania Ave., Washington, D. C.; H. K. Fulton, 1218 Pennsylvania Ave., Washington, D. C.; Geo. W. Spier, 310 9th St., N. W., Washington, D. C.; August Steman, 554 N. Gay St., Baltimore, Md.; W. C. Newman & Co., Hagerstown, Md.; Gordon & Burgin, 6 Winter St., Boston, Mass.; W. T. Cummings, Winchendon, Mass.; G. D. Wugman, 133 Market St., Newark, N. J.; Alfred Bourgeois, Jackson, Miss.

Chas. A. Rogers, formerly of Elmira, N. Y., has purchased Mrs. W. D. Hoff's jewelry store in Waverly, N. Y., and will take possession April 23d.



THE STAR OF EMPIRE WESTWARD TAKES ITS WAY

# WESTERN SUPPLEMENT OF THE JEWELERS' CIRCULAR

Chicago Office: Room 517, Inter-Ocean Building.

VOL. XXVIII.

CHICAGO, WEDNESDAY, APRIL 18, 1894.

NO. 11.

## Chicago Notes.

Oswald Fulde, 377 W. Division St., has returned from a tour of California.

Manager Sercomb and wife have returned from a week spent at West Baden Springs.

G. W. Marquardt, Sr. spent a week with the Chicago house, returning to Iowa Thursday.

Manager Forman, of Spaulding & Co., returned Monday from an eight days' business trip east.

H. C. Walton, secretary of the Wadsworth Watch Case Co., is on a two weeks' business trip east.

Emil Cowen, Detroit auctioneer for Morris Eppenstein, the Madison St. jeweler, was in the city last week.

G. Dilger, mentioned last week as a newcomer in the jewelry field, has opened a store at 419 Chicago Ave.

Bradley & Hubbard Mfg. Co., Mr. Merrick, manager, are soon to occupy new quarters in the Masonic Temple.

F. A. Jeanne, representative of Alfred H. Smith & Co., the past week visited Manager Rich, at the Chicago office.

J. W. Meacham, manager of credits for the Meriden Britannia Co., is accompanied by Mrs. Meacham on a visit through the south.

C. E. Davis contemplates selling his store at 701 63d St. on account of poor health. His physicians advise him to reside in the south.

Charles G. Wilson recently purchased the jewelry store of J. S. Blackney, 6062 State St. Mr. Wilson was formerly watchmaker for Marshall Field & Co.

The Western Automatic Music Box Co., of Chicago, have incorporated with a capital stock of \$1,000. Incorporators: W. M. Sherman, M. W. Sherman, B. C. Sherman.

C. M. Weber, of the Weber Co., has recovered from a severe attack of grip and pneumonia, covering a period of six weeks, though he was detained at home only the past week.

Speaking of the business outlook, Mr. Duncan, manager of the Illinois Watch Case Co., of Elgin, stated the factory was to-day making more cases than ever before in the history of the company.

Ed. Moore, formerly traveling salesman for Geo. H. Fuller & Son, has taken the position of house salesman with Moore & Evans. Mr. Moore is a brother of Geo. B. Moore, the head of the latter company.

The name of M. Loeb, of the Wadsworth Watch Case Co.'s Chicago office, has been added to the membership roll of the Phoenix Club, a down-town social organization with quarters in the Columbia Theatre building.

The J. M. & A. C. Johnston Optical Co., 182 State St., have leased for five years offices and salesrooms on the ninth floor of Champlain building, northwest corner State and Madison Sts. The company will move into their new quarters May 1st.

H. C. Korfhage, Racine, Wis., was in town April 10 trying to effect a settlement with his creditors on a basis of about 25 cents. A creditor stated to THE CIRCULAR correspondent that it is probable a settlement will be effected on that basis.

The remodeling of the building at 84-86 State St., by enlarging the halls and putting in a light shaft, necessitated the removal of C. F. Happel & Co. to the suite of rooms adjoining their present quarters on the north. The firm's street number is unchanged.

And now comes Manager Todd, of the Towle Mfg. Co., who smiles over a "brand new" family addition. Daisy Wilkes, a member of the famous Wilkes family, has given birth to a filly colt, from whom great things are expected. Daisy is the family pet.

A most encouraging sign for precious stone men is the statement that more orders are being received for expensive goods than for some months past. It shows that moneyed men are loosening their purse strings. Thus reports Mr. Titus, of Taylor & Titus.

Leases for the week in the Masonic Temple include A. M. Gratz, who takes room

301; A. Newman in room 300 and Lazarus & Pines room 411. The latter firm moves to the jewelry district from the West side. Messrs Gratz and Newman were formerly at 175 Madison St.

Schauweker & Chalmers, Venetian building, have added another large safe to their office fixtures. The battery of safes has been covered with a mahogany cabinet and the contents are now guarded by the Chicago Electric Protective Co.'s system of burglar alarms.

Ben Clettenburg, elected Clerk of the North Town on the Republican ticket at the recent civic election, is an old time jeweler, having formerly conducted a store on Division St. near Larrabee. Gustav Colliander, running for Supervisor of the North Town on the Democratic ticket, was formerly an employe of Juergens & Andersen.

On complaint of H. C. Pitts, jeweler, 285 Blue Island Ave., Michael McKee and James Mahoney, aged 9 and 11 years, respectively, were arraigned before Justice Dooley last week. The boys were caught by Mr. Pitts while in the act of stealing gold breastpins from his show windows. Each was armed with a long piece of wire. This they would insert through a small air hole which had been left under the window and then fasten the hook at the end of the wire upon a piece of jewelry.

Thomas H. Thompson, employed by the E. Howard Watch & Clock Co. for the past seven years died at his home, 3445 Armour Ave., April 1st, of heart failure, superinduced by pneumonia, after an illness of but two weeks. Mr. Thompson had advanced from the position of errand boy when the firm first established their Chicago office to the general supervisor of their city clocks, and stood high in the regard of the firm. The funeral was held at St. Thomas' Episcopal Church, April 3d, and the remains interred at Oakwoods. Among the floral offerings was a large floral dial from Harry E. Howard. The deceased was a brother of Sam W. Thompson, general salesman for Morse, Mitchell & Williams, and was universally esteemed.



Mrs. Carl B. Snyder, lady bookkeeper for the Racine Jewelry Mfg. Co., Racine, Wis., who was recently married, died suddenly of heart disease April 3.

H. E. Cobb, Chicago representative of Daggett & Clap, McVicker's Theatre building, left Friday for the factory on his semi-annual business trip.

John G. Hemmer, of John G. Hemmer & Co., Boyce building, returned to Chicago for a couple of days and left for Dakota and northern Wisconsin Wednesday night.

The Excelsior Sign & Mfg. Co., L. S. Grout, manager, will move the present warehouse into new and commodious quarters at northwest corner State and Lake Sts., at the head of the wholesale district. The move has been contemplated for some time and will give the company a better location, better light and better shipping facilities. In their new salesrooms the firm will carry a larger stock than ever before of signs and tools, finished and ready for shipment at a moment's notice.

"I want to show you the prettiest sight you ever saw," said A. Hirsch as he threw wide open the oak coverings and disclosed his battery of new safes of largest size occupying the east side of their new quarters on the fourth floor of the Masonic Temple. A handsome large vault was also shown. The outer doors, safes, vault door and chain cases are protected by burglar alarm coverings, thus saving the insurance

formerly carried. The new quarters are well equipped with private offices, reception rooms, and bookkeeping and shipping rooms,—all well arranged for the needs of a large business. The firm moved into their new quarters April 9th.

A. T. Evans denies the report in THE CIRCULAR of last week that he had incorporated a company as A. T. Evans & Co. "I can only say now," said he, "that it was a bold attempt to steal my name and that the incorporators named in the request for a license are unknown to me. I will again enter the jewelry business and have several opportunities under consideration but have not positively decided as to the course that will be taken. The probabilities are that A. T. Evans & Co. will be incorporated later to conduct a business with myself as manager." April 10 Mr. Evans filed a bill for injunction against Wm. A. Parkinson, N. G. Bornhofen, W. A. Benson, Geo. B. Moore (his former partner), E. L. Waugh and W. H. Hinrichsen (Secretary of State), restraining the parties from giving or receiving a license to incorporate as A. T. Evans & Co.

**Chicago Jewelers Will Close Early on Saturday.**

CHICAGO, Ill., April 14.—The following petition with signatures so far attached, was last week circulated among the trade from the office of the Chicago Jewelers' Association:

We, the undersigned jobbing jewelers, watch and jewelry manufacturers, manufacturers of and dealers in clocks, silver plated ware and kindred goods, hereby agree each with the other to close our respective places of business on Saturdays at 1 o'clock P. M., beginning May 5th and ending Sept. 1, 1894:

- |                                  |                                  |
|----------------------------------|----------------------------------|
| F. M. Spreehle & Co.,            | C. H. Knights & Co.,             |
| G. W. Marquardt & Sons,          | Louis Manheimer,                 |
| The Crescent Watch Case Co.,     | Stein & Ellbogen Co.,            |
| Brooklyn Watch Case Co.,         | Joseph Fahys & Co.,              |
| F. H. Noble,                     | O. W. Wallis & Co.,              |
| Geo. H. Fuller & Son,            | A. C. Becken,                    |
| Jules Racine & Co.,              | Heintz Bros.,                    |
| Richards & Rutishauser,          | M. A. Mead & Co.,                |
| Schauweker & Chalmers Co.,       | A. & L. Felsenthal,              |
| Reed & Barton,                   | The E. Howard Watch & Clock Co., |
| Simons, Bro. & Co.,              | F. E. Morse Co.,                 |
| C. F. Happel & Co.,              | Lapp & Flershem,                 |
| Katlinky & Gatzert Co.,          | A. Hirsch & Co.,                 |
| Moore & Evans,                   | Metzenberg & Co.,                |
| Waterbury Clock Co.,             | Ansonia Clock Co.,               |
| Seth Thomas Clock Co.,           | F. A. Hardy & Co.,               |
| Pairpoint Mfg. Co.,              | New Haven Clock Co.,             |
| B. F. Norris, Alister & Co.,     | Glickauf & Newhouse,             |
| Simpson, Hall, Miller & Co.,     | Wm. L. Gilbert Clock Co.,        |
| A. H. Smith & Co.,               | R. Wallace & Sons Mfg. Co.,      |
| United States Watch Co.,         | Keystone Watch Case Co.,         |
| The Holmes & Edwards Silver Co., | Manhattan Silver Plate Co.,      |
| Swartchild & Co.,                | Rogers & Hamilton Co.,           |
| H. Muhr's Sons,                  | Otto Young & Co.,                |
| Benj. Allen & Co.,               | H. F. Hahn & Co.,                |
| Meriden Britannia Co.,           | Wadsworth Watch Case Co.         |

A number of houses are yet to be seen, but the list above indicates a general desire of the trade to give the employes the advantage of a half holiday during the Summer season.

**TWO PAIR !!**



Two pair beat two of a kind in illustrating the advantages to be derived from dealing with Goldsmith Bros. In March Jewelers Joy and Happy, depicted in the left in the above illustrations, were two of a kind in their opinion of the firm. They agreed that the tests were accurate and valuations correct, and were pleased to get cash remittances on receipt of shipment. This month Jewelers Grumpy and Hardscrabble were overheard discussing their woes.

GRUMPY—No Sir; I'll never do it again.

HARDSCRABBLE, (testily)—Do what?

GRUMPY—Send stuff to Graball & Skinem, those sweep and old gold and silver fellows.

HARDSCRABBLE—Nor I.

GRUMPY—So you sent to them, did you? Well, I had been sending to Goldsmith Bros. and was satisfied, but thought I'd change. It was a change all right, but its Goldsmith with me hereafter.

HARDSCRABBLE—Me too; I changed, and wish I hadn't.

And they fell upon each others necks and vowed Goldsmith Bros. gave best returns.

TWO PAIR as an illustration win more to our standard than TWO OF A KIND.

**GOLDSMITH BROS.,**  
**GOLD, SILVER AND PLATINUM REFINERS,**  
 63 and 65 WASHINGTON ST., CHICAGO, ILL.



**San Francisco.**

Among the country dealers in this market recently were: A. Goldman, Bakersfield Cal., and Mr. Meyben, Chico, Cal.

A call among the jobbing houses in San Francisco reveals a state of encouraging activity. Orders are not as a rule large, but there are many small ones. Retail trade in 'Frisco is still quiet.

H. E. Hall, of A. I. Hall & Sons, left April 7th for New York. During his visit his headquarters will be at the Waterbury Clock Co.'s store of which company Messrs. Hall are the Pacific Coast agents. Mr. Hall will spend several days in the Metropolis, and he will stock up for the Fall trade.

**Rockford.**

The Rockford Watch Co., now running three days per week, expect to soon increase the working time.

The Skandia Jewelry Co. are going out of business and are selling the stock at auction. E. C. Keil, the manager, will embark in other business.

J. P. Drake, of the Rockford Watch Co., who died suddenly at Elmira, N. Y., the 11th inst., was for years a resident of this city. He was for nearly 15 years treasurer of the company and when he retired became the Chicago agent, later being transferred to New York. He was 60 years of age.

**Indianapolis.**

E. C. Miller has returned with his family from Hot Springs, Ark.

Ike Booth, Tipton, Ind., and A. Meissen, Cicero, Ind., were in the city last week.

W. H. Packard, Alexandria, Ind., has removed to New Prospect, O., where he is meeting with deserved success.

C. K. McCain, Kokomo, Ind., will shortly remove his jewelry stock into a handsome building which he has recently purchased in connection with other parties.

Local jobbers say that trade for March was as large as during the months of January and February combined. Manufacturers report March business far ahead

of the preceding months and as large as December.

The Burgheim Jewelry Store has removed from S. Illinois St. to 45 E. Washington St. Henry D. Burgheim is in charge of the watches and jewelry and his brother Edward is the optician of the firm.

April 16th, Chas. W. Lauer started on a trip through Indiana and D. J. Reagan through Illinois and Iowa for Baldwin, Miller & Co. John Gardner and Elliott Sims are just back from trips for Heaton, Sims & Co. All report trade slowly improving but orders light. The stocks of all country merchants are low.

Traveling men stopping in Indianapolis last week included: Mr. Steele, J. B. Bowden & Co.; Monroe Engelsman, Maurice Weil; Alfred Frank, Herzog, Goldsmith & Frank; A. W. Thankauer, for Ludwig Lehmann; Jos. Becker, Jos. Fahys & Co.; Chas. Roe, E. Ingraham Co.; F. W. Trewin, Keystone Watch Case Co.; W. J. Miller, Seth Thomas Clock Co.; and representatives of F. S. Gilbert, Regnell, Bigney & Co., and Hammel, Riglander & Co.



☞ TRUE Chuck for \$1.00 is the cheapest tool a watchmaker can buy. The Dale Chuck is always true, all kinds \$1.00.

MADE ONLY BY  
**HARDINGE BROS.,**  
1036 LINCOLN AVENUE, - CHICAGO.

**R. M. JOHNSON,**  
IMPORTER OF  
**Diamonds and Manufacturing Jeweler,**  
67 WASHINGTON STREET,  
ROOMS 5 & 6,  
CHICAGO.  
MASONIC EMBLEMS OF EVERY DESCRIPTION MADE TO ORDER.

**REED & BARTON,**  
**SILVERSMITHS,**

MANUFACTURERS OF

STERLING *and* SILVER PLATED  
SILVER WARE.

SALESROOMS:

**37 Union Square, New York.**

34-36 WASHINGTON STREET,

**Venetian Building, Chicago.**

FACTORIES, TAUNTON, MASS.

**DUEBER-HAMPDEN WATCHES.**

The most reliable watches are the Hampden 17 Jewel. A full line of Dueber Cases and Hampden Movements. Cash buyers write us.

**BRETHAUER WATCH & JEWELRY COMPANY,**  
SPECIAL AGENTS,  
71 WASHINGTON ST., - - - CHICAGO, ILLS.

**THE PLANCHAMP & BECKER CO.**

Makers and Repairers of

**WATCH CASES,**  
Gold and Silver Plating —

— of Watch Cases a Specialty.

UNEXCELLED FACILITIES.

53 and 65 East Washington St., Chicago.



WHEN IN CHICAGO, VISIT THE  
**Chicago Watchmakers' Institute,**

SUITE, 1521-1523 B MASONIC TEMPLE.

A Modern Trade School for the Watchmaker, Jeweler and Engraver.

Write for New Catalogue.



**The Suit of Chas. Ahrenfeldt & Son vs. Jaccard Watch & Jewelry Co.**

KANSAS CITY, Mo., April 14.—Charles Ahrenfeldt & Son, New York, have dismissed their suit in the Kansas City Circuit Court against the Jaccard Watch & Jewelry Co. More than a year ago the Jaccards ordered \$1,300 worth of goods from the New York firm. When the invoice was received it was alleged that the order was "padded" about \$875, and Ahrenfeldt & Son were notified that the goods would be held as on consignment.

Soon thereafter the Jaccard store was destroyed by fire and suit was brought by Ahrenfeldt & Son for \$875. At the trial a few months ago a verdict was rendered by a jury for the Jaccards, but error in the instructions caused a new trial to be granted.

The suit was finally dismissed without a second trial this week.

**Wisconsin Jewelers Form a Protective Organization.**

MILWAUKEE, Wis., April 13.—The Retail Jewelers' Association of Wisconsin was organized in the club rooms of the Plankinton House last evening, and the following officers elected: President, Richard Seidel, Milwaukee; vice-president, Charles A. Estberg, Waukesha; secretary, John Parsons, Madison; treasurer, D. Drummond, La Crosse. President Seidel, A. Blodel, James Gilowsky and August H. Stecher were appointed a committee to draft a constitution and by-laws, and to send to all the jewelers in the State a circular setting forth the aims of the association.

The meeting was called by Newton Dexter, secretary of the New York State Business Men's Association, and was attended by about twenty local jewelers. Mr. Dexter made an address on trade abuses, arguing that the best remedy therefor was organization. The vote of the jewelers present in favor of organizing was unanimous. After the trade throughout the State has been heard from, a meeting will be called in Milwaukee, not later than the middle of June, for the purpose of adopting plans for the correction of abuses now practiced to the detriment of retail jewelers. The Retail Jewelers' Association of Wisconsin will not immediately become a member of the National organization.

**The Stock of A. B. Brooks Jewelry Co. to be Sold.**

St. Louis, Mo., April 11.—In the assignment of the A. B. Brooks Jewelry Co., the assignee was ordered to sell stock and fixtures for cash at private sale for ten days, provided he obtains not less than appraised value; at the end of that time to sell remainder at public auction after giving public notice and mailing notice to creditors.

The appraisement of the stock of the company figures: Stock of goods, \$11,689.95; fixtures, \$734.41; total, \$12,424.36.

**Kansas City.**

Fire started under the store of J. M. Morrow, optician, 931 Walnut St., a few nights ago, doing several hundred dollars damage before being extinguished.

H. F. Sloane, of the Edwards & Sloane Jewelry Co., as a member of the Apollo Club, will take a prominent part in two concerts at the Auditorium this week.

The Jaccard Watch & Jewelry Co have received some novelties in glassware, with decorations painted on the inner surface of the transparent sides of the hollow pieces. They are making quite a hit.

Harvey Butler, Charles Meyers, Louis Worthier and Bert Bradley, the four young negro window smashers who broke into optician Julius Baer's store recently, were indicted by the Grand Jury last week.

The following country jewelers visited Kansas City last week buying goods: John Johnston, Wagoner, I. T.; L. S. Trower, Colby, Kans.; B. Hoffman, Leavenworth, Kans.; C. T. Clingenpell, Stockton, Kans.

Three boys, carrying several hundred dollars worth of silverware in sacks, were caught in the railroad yards here a few nights ago. Some of the articles were identified as having been stolen in St. Louis, and a detective from that city took the boys there for trial.

Joseph Rosemeyer, who broke the big plate glass window in the front of the Jaccard Watch & Jewelry Co.'s store and stole some silverware a few days ago, was indicted last week for the burglary, pleaded guilty, and was immediately sentenced to the penitentiary for three years.

**Physical Suffering Leads Frederick Irish to Suicide.**

DETROIT, Mich., April 14.—Dispatches to local papers state that Frederick Irish, a well-known watchmaker of Adrian, Mich., has committed suicide by hanging himself. He had been suffering from a complication of diseases for the past three years and this is assigned as a reason for the deed.

The deceased had been a jeweler and a resident of the place since 1836.

J. D. Quick, manager of the M. Huffman Jewelry Co.'s store, Edina, Mo., has left with his family for Binghamton, N. Y., where he has accepted a position in a wholesale jewelry house.

**BOLSTAD MFG. AND PLATING CO.,**  
(H. E. BOLSTAD, PRES.)

WATCH CASE MAKERS, REPAIRERS, PLATERS.  
PLATED INLAYING ON CASES.

**BEST WORK. BEST WORKMEN.**

170 MADISON ST., - CHICAGO.

**ELGIN HOROLOGICAL SCHOOL,**  
THOROUGHLY PRACTICAL,  
COMPETENT INSTRUCTORS.  
Send for Prospectus.  
**ELGIN, ILL**

**Jewelers' Auctioneer.**



**NEVER A FAILURE.**

References from over 300 Wholesale and Retail Jewelers in all parts of the country. Profits Guaranteed. Correspondence Confidential. Write for terms and details.

**501 MASONIC TEMPLE,  
CHICAGO.**

**PFEIL & OBERNDORF,  
MANUFACTURING JEWELER.**

**Diamond Work a Specialty.**

**BEST of Workmen.  
BEST Design Work.  
GUARANTEED Workmanship**

Send a trial order and be convinced.  
**182 State St., Chicago.**

**HUGO MUELLER,  
182 State St., (Room 70,) Chicago.**  
**FINE WATCH REPAIRING**

IN ALL ITS BRANCHES.  
Work for the trade promptly executed by skilled workmen.

**PARSONS & SCHOOL**  
—FOR—  
**WATCHMAKERS,  
PEORIA, - - - ILL.**

Send for Circular and Terms.  
**PARSONS & CO.**

EST. 1870. **DR. PETER HENRY,**  
SPECIALIST IN  
**WATCH • CASE • DISEASES**

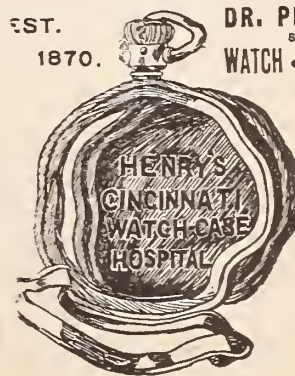

Key Winders  
changed to  
Stem Winders

Hunting Case:  
changed to O. F

English Cases  
changed to fit  
American  
movements

Can be cured at  
**53**

**Longworth St.,  
Cincinnati, Ohio.**



## PATENT FIBRE-FACED HAMMERS.

5 oz. for Watchmakers.  
10 oz. for Manufacturing Jewelers  
Price 50 Cents Each.

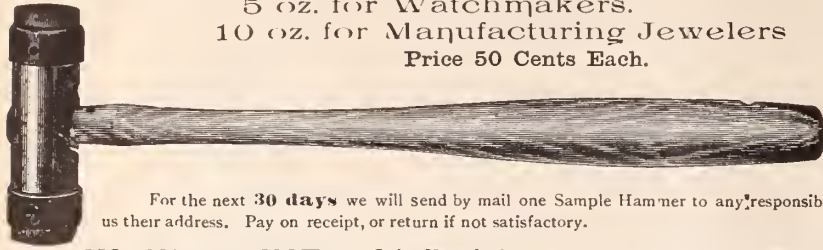

For the next 30 days we will send by mail one Sample Hammer to any responsible firm giving us their address. Pay on receipt, or return if not satisfactory.

**W. W. OLIVER, Sole Manufacturer, - Buffalo, N. Y.**

Send for our No. 10 Catalogue.

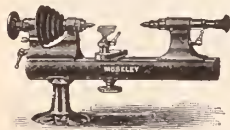

One of the best of the very best.

QUALITY IS THE STANDARD OF VALUE.

CHARGES TO SUIT THE TIMES.

When interested, write your jobber for new price list for 1894, or

**Moseley & Co., Elgin, Ill.**



No. 2 Moseley Wire Chuck has length, strength, accuracy.



## GIBSON HOUSE,

CINCINNATI, OHIO.

ABSOLUTELY FIRST-CLASS AMERICAN PLAN HOTEL.

\$3.00 PER DAY.

Extra Charge for Parlors and Rooms with Bath attached. The unequalled advantages in central location, liberal management, modern appointments, experienced service and perfect cuisine, have permanently established the Gibson House as The Most Popular First-Class Hotel in Cincinnati.

AMPLE VAULTS FOR THE PROTECTION OF VALUABLES.

**THE GIBSON HOUSE CO.,**

H. B. DUNBAR

President and Manager

... THE ...

## American Horological Institute

AND TECHNICAL SCHOOL OF LANCASTER, PA.,  
LATE OF PHILADELPHIA, PA.,

A Trade School where Watchmaking is taught practically. We do not manufacture

☀ BICYCLES OR DYNAMOS ☀

at this institute. We confine our work strictly to WATCH WORK and its kindred branches, which include

== Engraving, Jewelry Work and Optics ==

One tuition pays for all the branches. We do not have boy instructors at this institute, all men of years of experience. Each department has its separate instructor. Our institute is open for inspection. We kindly invite you to visit us and inspect our school modes of giving instruction and the progress that our students make by giving them practical instruction.

**THOMAS PENDERGAST,**

PROPRIETOR AND MANAGER.

## OPTICIANS' SCHOOL.

If you want a GOOD ROOF over your head, come to our school. We want EARNEST STUDENTS, leave the rest to us, we do not want diploma hunters.

The Chicago Ophthalmic College and Hospital,

H. M. MARTIN M. D., PRESIDENT. 607 VAN BUREN ST., CHICAGO

Being the oldest and most favorably known College of Theoretical and Applied Ophthalmic Optics in America, having more thoroughly qualified opticians in the field than all other so-called schools combined.

## Pacific Coast Notes.

Geo. A. Allen has a new store in Fresno, Cal.

H. Morton, San José, Cal. has closed his auction sale.

H. J. Kuechler, North Yakima, Wash., is having a reduction sale.

Chas. Daunt, Modesto, Cal., was married recently, his bride being a Miss Owens, of Modesto. Undaunted they propose to face life together.

B. W. Rowell, formerly of Orange, Cal., is opening a jewelry store at Tehachapi, Cal., on the line of the railroad over the mountains from Los Angeles.

R. L. Meadows, manager of the Winnepeg Jewelry Co., Manitoba, Man., is visiting A. F. Snell, the Orange, Cal., jeweler. The two gentlemen learned their trade together in Hamilton, Ont.

Alameda County, Cal., sent a mantel and clock to the World's Fair as a part of her exhibit. It transpires that a debt of \$500 remains on the clock and it is proposed by the county supervisors to raffle the clock to 1 ft the debt.

J. R. Andrews, a Modesto, Cal., jeweler, formerly followed the stage as a conjurer and now takes part in local benefit entertainments in his town. He is billed to perform some "black art" tricks, for the benefit of the local militiamen.

## Minneapolis and St. Paul.

B. Hasenput, for several years in the employ of S. Lacs, Minneapolis, as watchmaker, has gone into business for himself at 329 Nicollet Ave.

Wm. Segerstrom, St. Paul, who recently started a repair shop, has gone out of business, and has accepted a position as watchmaker with the I. B. Miller Jewelry Co., Minneapolis.

I. R. Bunker, for the past seven years watchmaker for G. R. Holmes, St. Paul, has severed his connection with that firm and has accepted a similar position with W. M. Stone, Minneapolis.

The schedules filed in the District Court, on April 5th, of Jesse Collom, Minneapolis, show assets to be \$1,472.94, and liabilities at \$1,916.95. The creditors in the trade are as follows: Spaulding Bros., \$9; F. Leward & Co., \$18; Rentz Bros., \$10; Dennison Mfg. Co., \$14.50; Weber Co., \$525; A. C. Becken, \$14; L. Black & Co., \$10.

Wm. M. Stone, jeweler, Minneapolis, was arrested on the 7th inst., charged by T. L. Berryhill, with assault and battery. Mr. Stone was immediately released on his own recognizance and had the case continued. It appears that Berryhill entered the store to look at some scarf pins and on being shown some stuck them back in the cushion and started to go. Stone, it is claimed accused him of stealing two of the pins and refused to let Berryhill go until he paid for the articles. The money was put up, and Berryhill returned shortly afterwards with a lawyer, demanded a settlement and





I. B. Miller, of the I. B. Miller Jewelry Co., Minneapolis, has removed his family from Chicago to that city.

Out-of-town jewelers visiting the Twin Cities the past week were: John Saxine, Prescott, Wis.; Jake Segerstrom, Rhinelander, Wis.; Lucien Diacon, Chaska, Minn.; and N. Anderson, Willmar, Minn.

**Detroit.**

I learn that John Keller, jeweler, Columbus Grove, O., made an assignment last week to John Lafferty.

Julian E. Doty, dealer in jewelry and drugs, Grand Rapids, Mich., has filed a chattel mortgage for \$140.

The Johnson Optical Co. are working nights to fill orders. Frank Kennedy, secretary, was in Port Huron last week on business.

L. Black & Co., New York, have moved their stock and business to 142 Woodward Ave., this city. A light manufacturing business will be conducted on E. Fort St. The firm were formerly established here, but decided that a concentration of business interests at this point was desirable. Ben Cohen and R. H. Cook, formerly in the New York office, are also here.

Judge Lillibridge has made an order confirming the sale made by Commissioner Greenstine, last Friday, in the case of Robt. H. Howard, trustee, vs. F. G. Smith, Sons & Co. The formal transfer has been made and a bill of sale filed with the city clerk. The firm have reorganized and are now doing business at 165 Woodward Ave., under the firm name of F. G. Smith & Sons.

Business last week showed an improvement over the three last weeks. A larger number of Michigan country jewelers purchased goods. Among them were: Mr. Baxter, Birmingham; N. Selkirk, Charlotte; C. E. Bell, Ewart; C. E. Montfort, Utica; A. E. Gardner, Milan; Fred Grimm, Mt. Clemens; E. Campbell, Pinckney; A. E. Hodey, Luther; Wm. Ambler, Northville; D. Rogers, New Haven; Wm. Becken, Brighton, and Mr. Bowman, Almont.

**Cincinnati.**

O. E. Bell & Co. are getting out a monster circular, containing all the "snap shots" of the season.

E. W. Blue, Atlanta, has issued a circular to his creditors announcing that he will give 10 per cent. in full settlement.

Clemens Hellebush is making a special feature of his United States clocks. He received an order for 100 Saturday.

Gustave Fox & Co. are sending out their new emblem catalogue. It is worth possessing, as it contains all the new and fancy designs.

Jos. Noterman & Co. made the badge of the season. It was a regatta for Austin, Tex., and measured 10 inches in diameter. The dome of the State capitol, imbedded with rubies, adorned the upper portion. The badge was in eight colors and was a most elaborate piece of work.

Among the first duties of the new Mayor, just elected, will be the collection of subscriptions for the purchase of the silver service for the steel cruiser *Cincinnati*, which will be completed this month, and go into commission in June. The fund was started two years ago and rested at \$3,450; \$5,000 is the sum desired and a big effort will be made to reach it. A meeting is soon to be called to determine about the service and its purchase.

**Settlement Effected in the Affairs of F. J. Essig.**

CHICAGO, Ill., April 16.—A settlement has been effected in the affairs of F. J. Essig, lapidist, who assigned voluntarily March 19th with stated assets of \$2,000 in precious stones to offset an indebtedness of \$5,000 due eastern stone men. "I have received a telegram from New York," said Edward T. Cahill, attorney for Mr. Essig, "that everything is all right, and the settlement is practically completed."

"On what basis?"  
 "Thirty-five cents on the dollar."  
 "In what form?"

"Tencents cash and 25 cents in three, six, nine and 12 months."

"Secured or unsecured?"

"The time payments are guaranteed."

"By whom?"

"It isn't necessary to state that. The creditors are satisfied with the guarantee and they are the interested parties."

The terms of settlement are better than were at first believed probable. Mr. Essig stating privately at that time that he hoped to be able to pay 25 cents. The firm the past week removed from 1222 Masonic Temple to their former quarters, 115 State St., giving them more room and a cheaper rent. They have the good will of the trade, and are equipped to do any work required in the cutting of precious stones.

**An Action Brought Over a Patented Elk Badge.**

CINCINNATI, O., April 16.—Montford S. Jones *et. al.*, of Louisiana, filed a bill in the United States Court some days ago, complaining of the infringement by the Herman Keck Mfg. Co., of this city, of the design for an Elk badge. An injunction went out with notice that the motion for a temporary order will be heard on the 14th. The defendants were not aware that such a suit was contemplated until they received notice of the injunction pending the hearing on the 14th. They immediately referred the matter to Jones & James, their attorneys, who will resist the suit to the last.

The case came up for hearing Saturday morning and after lengthy arguments the court decided the injunction was just and right to the complainants, therefore should continue until the final hearing of the case.

Gustave Fox & Co. are the manufacturers of the Elk badge referred to.

The jewelry store of David W. Neff, Royal Center, Ind., was burglarized last Monday night of over \$100 worth of goods. The thieves gained an entrance by cutting a panel out of the rear door and were evidently well acquainted with the lay of the land.

**JUST OUT!**

**Our New Illustrated Catalogue of . . . .**

**Watch Materials, Tools, & Jewelers' Supplies was issued MARCH 20th.**



IF you have not already received a copy notify us and we will send you one at once. We wish to emphasize that our Prices will be found the **LOWEST**, quality of goods considered. With a well selected stock we are enabled to fill all orders promptly and correctly.

**BENJ. ALLEN & CO.,**

141-143 STATE STREET,  
 . . . CHICAGO, ILL.

**Watches, Diamonds, Clocks and Jewelry.**



### Providence.

H. C. Simmonds has removed from 140 to 283 Westminster St.

Dutee Wilcox started for the west last week, going as far as Kansas City.

A judgment for \$210 has been obtained against Isador Hen'us in favor of Emory Bemis.

Julius Eichenberg has secured a judgment for \$212 against Coombs & Patterson, Pawtucket.

Fred Leonard, of J. M. Chandler & Co., has leased the Flint Building, at 109 Orange St., for a period of 10 years.

Ralph Hamilton is visiting the trade in western New York in the interests of Hamilton & Hamilton, Jr.

An important meeting of the directors of the Manufacturing Jewelers' Board of Trade will be held on the 21st inst.

E. F. Kent, of Kent & Stanley Co., was in New York last week in the interest of that concern's new factory building.

Walter Gardiner, of Dutee Wilcox & Co., has returned from a western trip and is confined to his house by sciatic rheumatism.

Charles B. Broome, until recently with Allen & Jonassohn, is arranging to start in the stone business for himself on commission.

Martin L. Read has accepted a commission from an extensive grower and dealer in Vermont to dispose of maple syrup and sugar in this vicinity.

John Gibson has retired from the firm of William Hamilton & Co., Mr. Hamilton having purchased his entire interest. The business will be continued under the old style.



**\$4.50**  
**Per Dozen.**

**Sterling Silver "TROLLEY" or Hat Guard for Straw Hats, unlimited Sale THIS YEAR. Gold and Silver Art Match Boxes, Diamond and Half Pearl Brooches, Swords and Scarf Pins. Repairing a Specialty.**

**CLARENCE W. SEDGWICK,**

**11 EAST 20th ST., - NEW YORK.**

A majority of the creditors of the Seery Mfg. Co. have accepted Assignee Parson's offer of 25 cents on the dollar and having signed, many of the claims have already been liquidated.

R. A. Breidenbach, New York, has been here the past few days making arrangements in the business of his Providence office, necessitated by the retirement as manager of Edward S. Stark.

The Campbell-Metcalf Silver Co. have been awarded the contract for making the Kirmess spoon for the entertainment at the Providence Opera House for the benefit of the Day Nursery this week.

Charles P. Sherman has recently started in the retail business at 149 Oxford St., and last Friday night before he had arranged his stock the store was burglarized and four watches, valued at \$100, were stolen.

Julian Rathbone, assignee for Harrington & White, having been unable to effect a satisfactory settlement with the creditors on the basis offered has decided to sell the stock, tools and fixtures at auction sale at 10 o'clock April 18th, at the shop, 59 Page St.

The case of Christopher Duckworth against E. S. Dodge was heard in the Appellate Division of the Supreme Court last week. This is a case involving a question in the settlement of an estate, wherein it was asked that a receiver be appointed. At this hearing a final decree was entered dismissing the petition.

The creditors of James R. Feeley have decided to accept the proposition of Assignee Vose of 25 cents on the dollar, cash payable within 30 days. At the recent meeting of the creditors the committee appointed to investigate the connection of William DeWolf with the defunct concern, reported that Mr. Feeley was alone liable for the liabilities and that consequently Mr. DeWolf's claim of \$3,527.97 would not be pushed. Mr. Feeley expects to be able to straighten his business out so as to re-engage in manufacturing about May 1st.

Henry McKinney, assignee for Martin L. Read & Co., has finished taking his inventory and finds the condition of affairs even better than was at first anticipated. The liabilities are between \$4,000 and \$5,000 while the assets will amount to more than \$3,000 in excess of that amount. A meeting of the creditors will be called in a few days when it is thought that it will be possible to obtain an extension. In all events it is Mr. Read's intention to pay 100 cents on the dollar.

Geo. E. Ginard and Martin Teeter are the incorporators of the Ginard & Teeter Co., Des Moines, Ia. The capital stock is \$5,000.

**HENRY ABBOTT,**  
MANUFACTURER OF  
**Stem-Winding Attachments**  
**FOR WATCHES,**  
No. 2 Maiden Lane, NEW YORK.

### Book Notes.

**The Book of the Fair.**—This is a most elegant and elaborate souvenir of the World's Columbian Exposition. It is a full and complete history and description of the World's Fair at Chicago, organization, buildings and exhibits, covering the whole ground, and is as full in detail as can be within the limits assigned, namely, 1,000 imperial folio pages of pictures and print, issued in 25 parts, of 40 pages each. Considerable space is devoted to illustrations and descriptions of the displays in the silverware, jewelry, horological and kindred lines. Parts 4, 5 and 6 are thus devoted, and will prove a great acquisition to jewelers in themselves. The price is \$1.00 for each part. The Book of the Fair is published by the Bancroft Company, Auditorium Building, Chicago.

**The Artist - Artisan Quarterly.**—John Ward Stimson's talented young students have produced an artistic and literary magazine of a high order in their initial number of the Artist-Artisan Quarterly, far in advance of the ordinary college publication. The frontispiece is an admirable engraving of the superintendent of the Institute of Artist-Artisans, John War Stimson, in working costume and pallet in hand. The artistic work of the students scattered throughout the pages of the magazine potently evidences the high training these young men and women receive in the various branches of art in this most excellent institute.

**Dollars and Sense.**—This is a handy little volume on the subject of advertising written by an expert, Nath'l C. Fowler, Jr., self-styled Doctor of Publicity. Its price is contained in the secondary rhyming part of the title, "For Fifty Cents." The Trade Co., 299 Devonshire St., Boston, Mass.

### Sudden Death of Charles H. Peck.

PROVIDENCE, R. I., April 13.—Charles H. Peck, for many years identified with the manufacture of emblematic jewelry in this city, while at his work as foreman in the emblem department of the works of S. & B. Lederer, early yesterday morning, suddenly dropped to the floor and expired before medical assistance could be summoned. He was 58 years of age. He had not been enjoying very good health for several weeks.

Mr. Peck commenced work at the jewelry business nearly a quarter of a century ago, and for a long time was employed by Charles F. Irons, and later by C. A. Russell & Co. About 10 years ago he commenced business with A. B. Day, as A. B. Day & Co., and continued as a partner until some six years ago, when it was decided to give up the manufacture of emblems and the firm dissolved, Mr. Peck retiring. He went to work for Kent & Stanley Co., and a short time ago was engaged by the Lederers as foreman of their emblem department.



**Trade Gossip.**

Sollinger & Mellish, a firm composed of S. Sollinger and J. H. Mellish, electroplaters, 17 John St., New York, recently started in business, and are pushing their way to recognition by the trade. They do gold, silver and nickel plating as well as all kinds of coloring, lapping and polishing.

"Always something new" is a motto which J. N. Provenzano, manufacturer of sterling silver novelties, 39 Union Square, New York, practices as well as preaches. His latest products in knives, scissors and hairpins as well as his many novelties in small wares, amply testify to this fact. His prices will always be found as low as is consistent with perfect workmanship.

The trade will be interested in the offers made in this issue by Cross & Beguelin, 17 Maiden Lane, New York, who are now pushing a line of emblem goods at remarkably low prices. This firm are recognized as headquarters for emblems of all descriptions, in gold, silver or rolled plate, and their illustrated catalogue which will be sent upon application, should be in the hands of every jeweler.

For a hard times sign the post watch sign No. 1000 of the Excelsior Sign & Mfg. Co., L. S. Grout, manager, Chicago, made expressly to fill a hard times want, is meeting with large demand. The following jewelers sent in their orders late last week: S. O. Huseh, Mt. Horeb, Wis.; N. J. Eddy, Portland, Mich.; John M. Caldwell; J. T. Burke, Wilmington, N. C.; J. W. Ware, Dunkirk, N. Y. It is an elegant sign at a low price for guaranteed wear.

A novelty for which there will undoubtedly be a large demand this Summer, is the "trolley," an attachment for straw hats, manufactured by Clarence W. Sedgwick, 11 E. 20th St., New York. In this article, of which an illustration appears in the advertising columns of this issue, Mr. Sedgwick has put on the market a novelty which is not alone desirable and useful, but attractive and ornamental as well. The "trolley" will be a seller from the start.

Despite the fact of general dull business with a corresponding reduction in the volume of sales, Foster & Bailey, Providence, R. I., are doing a steady mail order business, showing conclusively that the firm's goods are sellers in the truest sense. The firm are taking time by the forelock in strengthening the plant and making all manner of improvements in every department. In this way Foster & Bailey keep their pay roll nearly to the amount it reaches in good times, a fact which Providence tradesmen no doubt appreciate. A very desirable line of new goods will be shown by Foster & Bailey when the trade is prepared to place Fall orders.

A destructive fire in the Arcade, Scranton, Pa., burned out the jewelry store of W. J. Weichel. His loss is between \$4,000 and \$5,000, insurance \$2,500.

**An Interesting Address to Watchmakers and Jewelers.**

The following address was made by E. v. Seutter, Jackson, Miss., at the recent annual meeting of the Retail Jewelers' Association, held in Jackson. Though rather late, we deem it advisable to publish the address, it having received no publicity in the jewelry trade press heretofore.

GENTLEMEN:

Having been absent at the first meeting of this Association, a year ago, allow me herewith to thank you for the honor bestowed on me at that time, by being elected president of this our Retail Jewelers' Association.

As a member of this body, and, perhaps, the oldest jeweler in Mississippi, permit me to address a few words to you all, which, if not practical sober business, I trust will kindle in your minds dormant ideas, that often in the pursuit of business are kept in the background. Indeed our efforts for successful business are so constant, and often trying, that we forget to appreciate the elevated sphere we live and work in.

Let me give you some historic facts and glimpses that few of you if any, are aware of; and while the sequel of them is amusing, still they convey a lesson and show us in what high honor and far above other mechanical pursuits the science of horology once was held.

It is customary in royal families to teach the princes a trade. I always thought this was done for effect—to please the working class. However that may be, the emperor Wilhelm I. was a printer. Petrowitch, Peter the Great of Russia, was a practical ship carpenter and ship builder, centuries ago, when he elevated that then barbarous country. Louis XVI., king of France, not only was a watch and clock maker but an enthusiast in that "art."

When the Austrian ambassador and suit arrived in Paris to present him with an address from the Austrian court the king was nowhere to be found. There stood at the end of the main corridor of the royal

palace an immense ornamental clock, which had stopped, and the young king was in there to repair it, emerging with candle and tools in his hands to meet the bowing and scraping courtiers of Austria.

This monarch was such an enthusiast about horology (watch and clock making), that he seriously intended to admit all worthy horologists into the realm of nobility, and was only deterred, as tradition goes, by the contemplation of the oil stone and his soiled, dainty royal fingers. This latter historic glimpse not generally known was given me by my old friend Max Kuener in Vicksburg, when 45 years ago I learned of him to be a watchmaker; he, Max Kuener, having worked several years in Paris under the very shadows of the Louvre and the Tuilleries.

So, fellow watchmakers and jewelers, but for that naughty oil stone we might all be noble men to-day. But joking aside—the superior merit and refinement of our calling remains. There is no more highly educated and accomplished class of people than are the English lords, the higher nobility and the royal scions in Europe; and the compliment conveyed as above related from the source it came, though it were of a monarch of the frivolous time in France 150 years ago,—carries with it a truth and appreciation of the horological science and art. I say the high standing of our calling remains. Science, learning, mind work, clean and superior mechanical skill stamp our profession akin to art—noble art.

While these glimpses into the past lack practical business grit, they are at least of interest and food for thought. Perhaps the thought and consciousness of being representatives of a calling once especially honored and linked to art and science, will rouse us to just and honest pride, and to efforts to retain its high position among the liberal arts, and to stimulate us individually as members of the Retail Jewelers' Association, to aims of high standing, professionally and socially.

W. D. Brothie, jeweler, Sheffield, Ia., has left for Storm Lake, where he will locate in business.

**CROSS & BEGUELIN, 17 MAIDEN LANE, NEW YORK,**



960 GOLD PIN. \$15.00 doz.



944 GOLD PIN. \$12.00 doz.



986 Gold Lapel Button. \$8.40 doz.



1117 SCARF PIN. Gold, \$5.66 doz. Silver, 2.80 doz.



341 GOLD CHARM. \$43.20 doz.



421 CHARM. Gold, \$15.60 doz. Silver, 7.80 doz.



1131 PIN. Gold, \$8.40 doz. Silver, 4.20 doz.



1018 PIN. Gold, \$7.60 doz. Silver, 3.80 doz.



1130 Enameled Pin. Gold, \$9.60 doz. Silver, 4.80 doz.



832 GOLD PIN. \$15.00 doz.



803 GOLD PIN. \$10.80 doz.



1081 LAPEL BUTTON. Gold, \$12.00 doz. Silver, 6.00 doz.

**HEADQUARTERS FOR Emblems, Gold, Silver and Plate.**

Write for Illustrated Catalogue.



**Connecticut.**

Havalaïd, the jeweler who succeeds W. C. Barry & Co., Danbury, has opened with a fine stock of goods.

Henry L. Beach, for 25 years a superintendent for the E. Ingraham Co., Bristol, and who has just retired, has been presented with a gold watch, Masonic chain and an

arm chair by the employes of the factory.

The officials of the Wm. L. Gilbert Clock Co., Winsted, have notified their employes, 350 in number, that commencing April 16 the factory will operate five days a week instead of three and four as heretofore.

Gilbert Rogers, of C. Rogers & Bros., and

Charles Parker have been elected directors of the Meriden Cemetery Association and N. L. Bradley, of Bradley & Hubbard Mfg. Co., has been elected president of the Meriden Park Co.

Parker & Davis, the Bridgeport jewelers, have just furnished the Woman's Auxiliary of that city with an elegant eight day clock.

Jeweler and optician L. V. R. Hubbard, Shelton, has been appointed chairman of the Union Veterans' Union Committee to decide upon a proposition to accept a gift of a plot in the Riverside Cemetery for a monument to the soldiers of Huntingdon.

The barn of David Yudkin, the Ansonia jeweler and pawnbroker, was set on fire last Tuesday night, but by timely work by Mr. Yudkin the flames were extinguished. Mr. Yudkin's store was robbed of watches by a burglar only a few nights previous.

The United Brass Workers, Metal Polishers and Platers of America, which comprises a membership of 20,000 scattered over the United States and Dominion of Canada, are preparing a souvenir for the seventh annual convention and anniversary which will be held at Waterbury, July 9, 10 and 11, 1894.

Waterbury has a first-class contest among the Democrats for the postmastership and a general election was held among the Democrats Wednesday to express their preferences. Chris. Strobel, the popular Waterbury jeweler, who has a large following among the voters was called upon to enter the arena and proclaim himself a candidate. This upon reflection, he declined to do. A variety of delegations visited him to shake his resolution but it was of no use.

**DIAMONDS.**

**Wm. S. Hedges & Co.,**

**Importers of Diamonds,**

And Manufacturers of DIAMOND JEWELRY.

**170 Broadway, New York.**

22 Holborn Viaduct, London.

**R. A. KIPLING,**

Importer of

**PRECIOUS STONES,**

**21 & 23 Maiden Lane,**

19, RUE DROUOT,  
PARIS.

New York.

**ONE YEAR'S SUBSCRIPTION**

—TO—

**The Jewelers' Circular**

—At \$2.50,—

Entitles the subscriber to a copy of "WORKSHOP NOTES" free, a 200 page book, bound in cloth, containing a fund of information for the workshop that can be found in no other work.

**Alfred H. Smith & Co.,**

IMPORTERS

**DIAMONDS**

AND

PRECIOUS STONES,

**182 BROADWAY, COR. JOHN STREET,**

**NEW YORK.**

33 Holborn Viaduct, London, E. C.

**Lancaster.**

Ernest Zahm has recovered from his severe and prolonged attack of pneumonia.

S. Kurtz Zook, jeweler, of this city, has just filled a large order for silverware for the Millersville State Normal School.

Among the traveling men in Lancaster the past week were: W. S. Davis, H. Muhr's Sons; F. Van Olinda, Wm. L. Gilbert Clock Co.; F. A. Brennan, of J. J. Cohn; J. W. F. Ehlers; Mr. Bliss, Gorham Mfg. Co.; A. D. Miller, Pairpoint Mfg. Co.

**Syracuse, N. Y.**

Eugene B. McClelland returned Saturday night from a few days' stay in the metropolis.

C. W. Haven, of Joseph Seymour, Sons & Co., who has long been a prominent member of the Uniformed rank of the Knights of Pythias, and who has held the rank of Major on the staff of Brigadier General Severance, of Albany, has just received his commission to a new honor. General Severance has been succeeded by Gen. Chas. A. Lutton, of Amsterdam. The new commission is from General Lutton to his staff as Assistant Quartermaster-General with the rank of Colonel.

**STERN BROS. & CO.**

CUTTERS OF

**DIAMONDS,**

WORKS:

29 & 31 Gold Street,

33 to 43 Gold Street,

NEW YORK.

OFFICE,

30 MAIDEN LANE,

NEW YORK.



### Fashions in Jewelry and Silver-ware.

A LADY'S RAMBLES AMONG THE JEWELERS.

Thimbles in view of Spring sewing are prominently shown.

A new spoon has an Egyptian design of lotus leaves on the handle.

Silver vinaigrettes with enameled panels are among things new and pretty.

The prettiest of the new prayer books are of white morocco bound in silver

Portraits in Limoges enamel set in silver frames make the heads of paper cutters.

Toy teapots, ewers and basins of silver are introduced as presents for children.

Silver standards for fruit knives come in new shapes. The knife blades are in silver gilt.

With the exception of the new table ware in silver gilt, there seems to be few changes in silver.

Mucilage bottles and perfume bottles seem to vie with one another in new and attractive forms.

Round fire opals set with diamonds form a beautiful scarf pin. Turquoise shares the opal's favor.

Paper knives of mother-of-pearl, with handles of silver wire uniting in pretty forms, are new.

Silver bordered prayer books have not been so conspicuously religious in ornamentation as floral.

The new sponges for the library are luxuriously encased in repoussé silver and set in embossed trays.

The silver buckles with ribbons for collar bands are furnished even to the hooks and eyes for fastening in the back.

The use of dental floss has brought out many pretty designs. The same holders may be used for embroidering silks.

An aquamarine with an antique head in high relief was set in a frame of ruby spinels and olivines connected by small diamonds. This was a work of art.

New white morocco purses and card cases have flat borders of gold or silver gilt, not ornamented, but highly burnished. These are marvelously elegant and quiet.

A silver standard for menu cards has a convolvulus with its lip upturned at the side. This is for the nosegay and is an idea that will appeal to the hospitable hostess.

Jewelers of romantic fancy provide deep petaled flowers which enclose little white ring boxes for the presentation of jewels. These floral emblems are chiefly used over the footlights.

Fancy pencils for the watch chain seem from their frequency to be much sought after. Some of them are very ingenious, the pencil running through pigs, dogs, monkeys and other animals.

ELSIE BEE.

ESTABLISHED 50 YEARS.

## RANDEL, BAREMORE & BILLINGS,

IMPORTERS OF

# DIAMONDS,

AND OTHER PRECIOUS STONES.

FINE PEARLS A SPECIALTY.

MANUFACTURERS OF

# DIAMOND JEWELRY,

IN THE LATEST DESIGNS.

Diamonds Recut in Modern Styles or Repaired on Premises.

58 Nassau Street,  
29 Maiden Lane  
NEW YORK.

1 Tulp Straat,  
AMSTERDAM.

1 St. Andrews St.,  
Holborn Circus,  
LONDON, E. C.

ESTABLISHED 1841.



TRADE MARK.

## CARTER, SLOAN & CO.,

### MANUFACTURERS OF GOLD JEWELRY,

No. 15 MAIDEN LANE,

NEW YORK.

A. CARTER, JR.  
A. K. SLOAN.  
C. E. HASTINGS.

GEO. R. HOWE.  
WM. T. CARTER.  
WM. T. GOUGH.

FACTORY, NEWARK, N. J.

## JOHN N. DISSELKOEN,

Cutter and Importer of

# DIAMONDS

FACTORY.  
76 LANGEBLEEKERSPAD  
AMSTERDAM.

19 East 16th St.,  
NEW YORK.

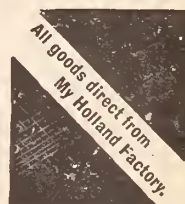



### Sterling Silver Legislation in Rhode Island.

PROVIDENCE, R. I., April 12.—A few days ago a bill was enacted by the Rhode Island Senate regulating the manufacture and sale of goods marked "Sterling" or "Sterling Silver" "Coin" or "Coin Silver." It was also passed by the House of Representatives without any opposition. After its passage by the latter body, but before notice of such action had been communicated to the Senate, Representative Henry G. Thresher, of Waite, Thresher Co., discovered several points in it which he thought would mitigate against the interests of Providence manufacturers, and consequently he obtained permission from the House to reconsider the passage thereof and to have it referred back to the judiciary committee for hearings. The bill as introduced and passed is as follows:

#### AN ACT TO REGULATE THE SALE OF GOODS MARKED "STERLING," OR "STERLING SILVER," OR "COIN," OR "COIN SILVER."

*It is enacted by the General Assembly as follows:*

SECTION 1. Any person who makes or sells, or offers to sell or dispose of, or has in his possession with intent to sell or dispose of, any article or merchandise marked, stamped or branded with the words "Sterling," or "Sterling Silver;" or encased, or enclosed in any box, package, cover or wrapper, or other thing in, by or which the said article is packed, inclosed or otherwise prepared for sale, or disposition, having thereupon any engraving, or printed label, stamp, imprint, mark or trade mark, indicating or denoting by such marking, stamping, branding, engraving or printing, that such article is sterling or sterling silver, unless nine hundred and twenty-five-one-thousandths of the component parts of the metal of which the said article is manufactured, is pure silver, shall be imprisoned not more than six months, or fined not more than five hundred dollars for each offence.

SEC. 2. Any person who makes, or sells, or offers to sell or dispose of, or has in his possession with intent to sell or dispose of, any article of merchandise marked, stamped or branded with the words "Coin," or "Coin Silver"; or encased or inclosed in any box, package, cover or wrapper, or other thing in, by or which the said article is packed, inclosed or otherwise prepared for sale, or disposition, having thereupon any engraving, or printed label, stamped imprint, mark or trade-mark, indicating or denoting by such marking, stamping, branding, engraving or printing that such article is coin or coin silver, unless nine hundred one-thousandths part of the component parts of the metal of which the said article is manufactured is pure silver, shall be imprisoned not more than six months or fined not more than five hundred dollars for each offence.

SEC. 3. This act shall take effect upon its passage.

A hearing was given on Tuesday and was largely attended, among those present being J. F. P. Lawton, secretary of the Gorham Mfg. Co.; George H. Kettlety, a jobber; John A. Jerauld, of E. A. Brown & Co.; Henry G. Thresher, of Waite, Thresher Co.; William A. Schofield, of Lambert, Schofield & Co.; Joseph P. Burlingame, William Patt, Herman Kern and others.

Mr. Lawton spoke in favor of the bill. He said in substance: "I regret that this hearing is held to-day as our company, the Gorham Mfg. Co., favor and ask for the passage of this bill. It was originally intended that the president and vice-president of our concern from New York would appear in our behalf before this committee,

but the appointment of the hearing for to-day necessitated a change in these arrangements and I have been obliged to appear instead. Why do we favor this bill's passage? Not from any selfish motive but in the interests of honest manufacturing. In France and England there are very stringent laws governing these matters, and something of this sort should be enacted in this country. This is not only necessary but we must have them. Previous to 1868 the standard of silver was coin silver or 900-1000. Then the Gorham Mfg. Co. adopted their standard, the sterling of England, 925-1000. Thousands of dollars have been spent since that time in educating the people of this country up to this standard until now the word 'sterling' means something with them. This is demonstrated from the fact that the manufacturers recognize it by stamping all grades of goods with that mark. This being the case all we ask is that some law be passed in the interest of honesty which will eradicate this deceptive method of offering goods for sale. Why should this bill be made to reach the dealer is a question which I have been asked. We have means of knowing that inferior goods bearing the sterling mark have been placed in the cases side by side with the higher classes of goods and when a purchaser has asked for sterling goods, the cheap article has been tendered them. Who are the purchasers of these goods? The rich? Not by any means. It is the middle classes who are the purchasers; why even the mill girl will have her set of solid silver spoons as a present when she is married, and it is in a measure for the protection of this latter class that such a law should be passed."

Chairman Honey, of the committee, suggested that he should think that the magnitude of the production and extent of the business of the Gorham Mfg. Co. would require Congressional legislation, whereupon Mr. Lawton replied that it was the intention of the Gorham Co. to endeavor to obtain such legislation and that papers for this purpose were already en route to Washington.

Mr. Thresher, in replying to Mr. Lawton, and in opposition to the bill, stated: "I represent several manufacturers in this matter. Some who make silver goods and others who do not. All classes of manufacturers are directly interested in this bill from the fact that it partakes of the nature of class legislation and if this bill is passed we do not know how soon another may be introduced regulating gold work. This bill was sprung upon the Senate and passed through without any opposition, no one but the paid attorney of the Gorham Mfg. Co. being present at the hearing. In the House it was railroaded through and in consequence has been reported all over the country as having been enacted as a law. Fortunately the detrimental effects of some of the clauses were discovered in time to stop its final promulgation and hence this hearing in which you see displayed a considerable amount of opposition. The opposition is not to the

bill as enacting a law in the interest of honest manufacture, for there is not a manufacturing jeweler in this city or State who would not gladly welcome the enactment of such a law; not by this State, for that would work prejudicial to their interests, but a National law wherein the standards of all grades of jewelry should be defined. This, I say, would be hailed with joy by them, for it is in this respect that the manufacturer has to contend in the most degree in competing with his rivals. A firm commences to manufacture an article with a certain standard, and places it upon the market with a good degree of success. It is soon duplicated by another manufacturer, but of a lower grade, and so the thing goes until at length the grade is far below the original standard.

"The Gorham Mfg. Co. comes here at this time seeking a protection which they have already got in their own name, and further than which this Legislature cannot give them. All of their competitors are large concerns and located outside of this State, so that even should you pass this bill it would not afford them what they want. But, Mr. Chairman and gentlemen of the committee, it would compel a great many small manufacturers in this city to renounce a certain class of trade which would simply go to the Attleboro and to Newark, where the manufacturers were not hampered and crippled by such a restriction as this will prove to be. There are manufacturers in this city who make the lower grades of goods because they have a class of trade who demand it, and demand that they be marked in accordance with the wishes of their customers. A large majority of these goods are sold in the dry goods and department stores, stores which the Gorham Mfg. Co. advertise that they will not supply, and although many times stamped sterling in order to comply with the demands of the dealers and of the public, there was no deception practiced, because the people knew that they could not purchase an article the same as they saw in the window of a leading jeweler marked at \$3.50 in the department store for 25 cents. They at once knew that the latter was an inferior article, even though it was marked sterling." Mr. Thresher denied that the word "sterling" had any distinct dictionary meaning which indicated  $\frac{925}{1000}$  fine; this was simply a standard which the Gorhams claimed to have educated the people up to. In conclusion, he said that the jewelers were almost a unit in favor of the adoption of a National hall-mark for both gold and silver goods, and that if a petition was started that he felt confident that it would receive the signature of every manufacturer in Providence. But the passage of a law applicable simply to the manufacturers of this State would be suicidal policy, and would certainly kill many of the small manufacturers engaged in this line of work.

N. Larson will remove from Elgin, Ill., to St. James, Minn.



### Boston.

Buyers in town the past week included: J. E. Chickering, Suncook, N. H.; Wallace P. Myers, Derry, N. H.; C. M. McFarland, Worcester, Mass.

The third meeting in the insolvency case of A. W. Anthoine was held Friday, and adjournment was made to May 25th, when the final settlement will take place.

The quarters occupied by Robbins, Appleton & Co. are in the hands of the carpenters. Some of the firm's surplus room will be set aside for the use of the Crescent Watch Case Co., and an extensive rearrangement of the interior is in progress.

Edward Ducharme, the man who daringly threw a brick through the show window of the store of jeweler Wm. B. Morse, on Tremont, near Hollis St., with intent to commit larceny, was last week sentenced to 18 months in the House of Correction.

The police arrested, a few days ago, Henry Hale, formerly an instalment pedler, but recently a farmer employed by Otis Farrar in Hudson. Hale is about 35 years of age, and it is alleged has obtained by false pretences jewelry worth about \$375 from the firm of Gately & O'Gorman, 611 Washington St. Hale, it is said, sent a letter to that firm in the name of his employer, Mr. Farrar, and claimed that he was a farmer with considerable property. Everything was thought to be all right and he went to the jewelry store and obtained the property with the alleged purpose of selling it on the road. As the jewelry firm did not hear from him for some time, it sent a letter to Mr. Farrar at Hudson and then learned the fraud. Hale was held in \$500 for the May grand jury.

### Philadelphia.

Harry Schimpf has returned from a business trip to Pittsburgh.

John F. Simons spent several days at Atlantic City last week.

Clarence C. Riggs has returned from a business trip to New York and New England.

The sale of the stock and fixtures of the H. M. Betz Watch & Jewelry Co. on Saturday last realized over \$20,000.

J. C. Irving, Hagerstown, Md., and W. S. Brown, Mt. Holly, N. J., paid purchasing visits to Philadelphia last week.

Albert T. Fritz, 1028 Arch St., made an assignment Friday to Wm. G. Rothermel. The deed conveys no real estate. Neither assets nor liabilities are large.

H. T. Wolf on Friday made an assignment to Simon Muhr. The deed conveyed among other things a legacy of \$2,000, bequeathed by Richard Wistor, deceased. Mr. Wolf was formerly of Wolf & Zernkilton, diamond setters, at 7th and Chestnut Sts., and Mr. Muhr was his heaviest creditor.

Thomas Linton Plucker, alias Lord Lionel Harcourt Harburg, a swell swindler, was committed for court here Wednesday on

various charges of swindling, obtaining money by false pretenses and passing forged paper. Among the victims were H. O. Hurlburt & Sons, 933 Market St. At the hearing Mr. Hurlburt testified as follows: "The prisoner came to our store last December and obtained a watch and a small amount of change, by presenting a check signed, 'J. J. Plucker.' We knew his father, but when the check came back marked 'no account,' we sent for the father, who said that the signature was not his, and that his son was a bad boy and that he deserved to be sent to State's prison." Plucker admitted this charge among several others.

Henry L. Perrett, for many years in the jewelry business on Chestnut St., below 4th, died at his residence in Merchantville, N. J., on Thursday last. Mr. Perrett was a native of Switzerland. Nearly 40 years ago he established the business on Chestnut St. He occupied the same place until eight years ago when he retired. As a watchmaker he made a reputation for ability in delicate and intricate workmanship that extended throughout the country. Mr. Perrett was in his 64th year and his death was due to a complication of diseases resulting from the grip. The funeral Monday was attended by a numerous delegation representing Masonic organizations to which Mr. Perrett belonged.

### Pittsburgh.

Leo Weil has gone to Europe to settle an estate which he has lately inherited.

Clyde J. Sankey will leave this week for a trip through Ohio combining business with pleasure.

Ernest Blank is back with Emanuel De Roy, having given up his business on Penn Ave.

W. J. Sarver, Allegheny, has taken a bicycle agency in connection with his jewelry business.

S. L. Ginsburg denies that Leo Weil will be his representative as published in the CIRCULAR, April 4.

E. J. Markland, a popular salesman with E. P. Roberts & Sons, has embarked in the furniture business.

Emanuel De Roy is bargaining for Fifth Ave. property, and in event of purchase will erect a handsome store.

R. T. McGeagh, Fifth Ave., has started the erection of five large buildings on Fifth Ave., near High St., to be used as stores.

James Cohn has started in the jewelry business on Fifth Ave. opposite Chestnut St. and has secured an advantageous location.

R. H. Wolf, Smithton, Pa.; Bert Neville, Dawson, Pa.; L. E. Harmon, West Newton, Pa.; and H. H. Weylman, Kittanning, Pa., were here last week.

Heeren Bros. & Co. are located in their new stores, which are complete and handsome in every detail. The lighting of the

building is a great feature, the large show cases on the walls being illuminated. The old building on Wood St. is now occupied by Adams Express Co.

Burglars on April 12th entered the store of Creutzer & Tonnel, located on Fifth Ave., near the B. & O. depot in the center of the business district of McKeesport and succeeded in escaping with about \$200 worth of jewelry. Entrance was effected by boring and sawing a hole 12x14 inches through the rear of the building. A hammer, saw and chisel were found in the store.

The sudden death of Mrs. Susie Withrow, wife of Dr. J. M. Withrow, of Cincinnati, and daughter of G. B. Barrett, this city, was a severe shock to her relatives and many friends here. Mrs. Withrow died suddenly on the evening of April 7. She was a charming woman, an artist and musician, and profound sympathy is extended to the family in their bereavement.

Herman Hubers, Baltimore, Md., has given a deed of trust to secure creditors.

The Stanley & Camp Co., Milwaukee Wis., will remove May 1st to an elegant new store on the southeast corner of Broadway and Mason St., one block north of their present location.

## THE CHARMILLES WATCH



is a new departure in watchmaking. It is the invention of Albert H. Potter, one of the most celebrated and scientific watchmakers living, and is protected by numerous patents the world over. The movement and case are one and the same, thus permitting a *higher quality movement* at the expense of the case—producing a *finely finished solid nickel movement* cased in the least expensive and simplest form, giving a *better value for the money* than higher priced watches.

The stem winding and pendant hand setting mechanism is simple, durable and *positive in action* and is a feature of the watch.

It consists simply of two upright wheels set in a solid block, one engaging in an intermediate winding wheel, the other in an intermediate face wheel. Pulling the stem out engages the hand setting wheel, pushing it in engages the winding—each operation is *positive*—no jumping of hands.

This device is to be found *exclusively* in the "Charmilles" watch and only needs to be seen to be appreciated.

Because the *price is low* "Charmilles" watches must not be classed with the many inferior watches with which the market is flooded and the Jeweler's reputation jeopardized.

"Charmilles" watches are suited to the times—the *greatest value for the least money*.

Illustrated Price List with full descriptions and prices mailed upon application to any leading Jobber.

## The Latest Triumph.



## Our Traveling Representatives

Traveling representatives may consider these columns open for the publication of any news or items of interest regarding themselves or their conferees.

**E**ASTERN jobbers and manufacturers represented in the Twin Cities the past week were: Louis Kaufman & Co., by Nat Wolf; F. H. Noble & Co., by H. C. Van Pelt; The Manhattan Silver Plate Co., and the

Holmes & Edwards Silver Co., by A. E. Hall.

D. H. Lowman starts to-day for the west in the interests of Lissauer & Co., 12 Maiden Lane, New York.

U. E. Hofer is now representing the Edwards & Sloane Jewelry Co., Kansas City, Mo., on the road.

H. C. Pfaffle, of O. E. Bell & Co., has returned from an extended southern trip. Trade the last two weeks, from Texas northward, has steadily declined.

Abe Harris, representative for R., L. & M. Friedlander, New York, returned to New York early in April and is now starting for the road again. Al. Oppenheimer, diamond salesman for the same firm, is at present on his eastern trip, reporting very fair business.

D. B. Ward, traveling salesman for Woodstock, Barger & Hofer, Kansas City, Mo., returned last week from a trip through Kansas and Oklahoma. He will leave this week for southern Missouri and Arkansas. Business, he says, is poor in the territory he has visited.

Traveling men visiting Davenport, Ia., during the past week were: F. R. Horton, Carter, Sloan & Co.; M. Gattle, Falkenau, Oppenheimer & Co.; V. L. Burgesser, Krementz & Co.; and A. Jandorf, New York; E. J. Koch, Mt. Washington Glass Co., New Bedford, Mass.; C. F. Liverman,

Middletown Plate Co.; C. H. Pixley, F. A. Hardy & Co.; John E. Ford, Otto Young & Co., Chicago; W. J. Carrow, Mandeville, Carrow & Crane; Wm. L. Supple, Wm. B Kerr & Co., Newark, N. J.

Among the traveling men who visited Boston the past week were: H. Slochem, Max Freund & Co.; H. E. Bleecker, Bassett Jewelry Co.; Charles Gallagher, Sinnock & Sherrill; Eph. A. Karelson, M. D. Rothschild; C. L. Power, Ludeke & Power; Ludwig Nissen, Ludwig Nissen & Co.; H. A. Freese, Lewis, Kaiser & Luthy; David C. Townsend, E. Aug. Neresheimer & Co.; Walter Gardiner, D. Wilcox & Co.; Levertt S. Lewis, Randel, Barmore & Billings; Mr. Goodfriend, Goodfriend Bros. & Lassner.

The following traveling salesmen passed through Detroit last week: C. C. Offerman, Wm. Smith & Co.; Mr. Battey, Waite, Mathewson & Co.; Mr. Matscke, Kuhn, Doerflinger & Co.; D. H. Lowman, Lissauer & Co.; Mr. Gregory, Strobell & Crane; M. Stratton, Jno. W. Reddall & Co.; L. E. Fay, Kirby, Mowry & Co.; Thos. E. Rogers, Hayes Bros.; G. W. Payson, Seth Thomas Clock Co.; J. W. Mindel, American Watch Case Co.; W. C. Coombs, E. F. Sanford & Co.; D. I. Byers, Cincinnati Gold & Silver Refining Co.; Louis P. Cook, J. F. Fradley & Co., and Wm. T. Gough, Carter, Sloan & Co.

Men of the sample case whom Chicago is pleased to meet included last week: F. E. Heffron, Riley, French & Heffron; Mr. Robinson, Richard Robinson & Co.; Thomas H. B. Davis, Middletown Plate Co.; Mr. Corbett, Alvin Mfg. Co.; Lou Fay, Kirby, Mowry & Co.; I. C. Nicholson, Flint, Blood & Co.; Mr. Willemin, H. Muhr's Sons; C. A. Whiting, Wade, Davis & Co.; H. A. Bliss, Krementz & Co.; John Nathan, Rothschild Bros.; J. E. Blake, Blake & Clafin; C. O. E. Hartung, Sussfeld, Lorsch & Co.; Mr. Briggs, W. F. Briggs & Co.; Wm. Mount, J. J. Sullivan, James Peacock, R. L. Moorhead and J. B. Ostoff.

The jewelry trade of Syracuse, N. Y., was favored with calls from the following traveling salesmen the past week: Geo. S.

Pollitz, Rice & Hochster; Herbert E. Slater, Champeinois & Co.; Frank L. Flint; Rest Fenner Smith Co.; Mr. Stone, The James W. Gibson Co.; Frank W. Harmon, M. B. Bryant & Co.; Th. Meyer; Mr. Sylvia, Mt. Washington Glass Co.; Alfred E. La Vigne, Mathey Bros., Mathez & Co.; F. F. Braillard, Braillard & Pflugsten; Geo. W. Smith, Carter, Sloan & Co., E. H. Cox, Sussfeld, Lorsch & Co.; N. Coughlin, William Link; W. S. Taylor, W. S. Taylor & Son; W. C. Tappan, D. F. Briggs Co.; C. E. Battey, Waite, Mathewson & Co.; Geo. Osborne, Wm. Smith & Co.

Travelers in Pittsburgh, Pa., last week were: William Biggard, for I. Ollendorf; Harry Osborne, Whiting Mfg. Co.; Tom Rogers, Hayes Bros.; N. A. Sambolino, Jacot & Son; Jos. Beach, Wilcox Silver Plate Co.; David Kaiser, Lewis, Kaiser & Luthy; M. Matscke, Kuhn, Doerflinger & Co.; Mr. Wilcox, Rogers, Smith & Co.; S. Ettinger, Keller, Ettinger & Fink; Geo. D. Munson, Wm. Rogers Mfg. Co.; A. D. Miller, Pairpoint Mfg. Co.; L. Adler, B. H. Davis & Co.; W. L. Pollack, W. L. Pollack & Co.; G. A. Webster, E. G. Webster & Son; E. H. Smith, Holmes & Edwards Silver Co.; Louis P. Cook, J. F. Fradley & Co.; Josh W. Mayer, Powers & Mayer; Thos. F. Magrath, for J. Pouyat; Geo. Nelson Fenn, for C. Sydney Smith.

Lafayette F. Harrison, for many years a salesman for the Wilcox Silver Plate Co., 6 Maiden Lane, who was well-known and liked throughout the jewelry district, died of consumption Tuesday evening, April 10th, at Sierra Madre, Los Angeles Co., Cal., where he had gone for his health. Mr. Harrison was about 41 years old. He was for many years employed by Carter, Howkins & Dodd, the predecessors of Carter, Sloan & Co., as entry clerk and traveling salesman, and later by Post & Spier. After the failure of the latter firm, 16 years ago, he became salesman for the Wilcox Silver Plate Co., where he remained until his death. Last Christmas his health became bad and he was forced to go to California. The remains have been shipped east for burial. Mr. Harrison lived at Greenville, N. J. He leaves a widow but no children.

# JOHN R. KEIM, MANUFACTURER OF

## FINE DIAMOND JEWELRY,

21 East 17th Street, New York.

SOLE AUTHORIZED MANUFACTURER OF THE PALMER COX "BROWNIE" JEWELRY. AND ALL ARTICLES IN ENAMEL OR METAL; BY PURCHASE FOR THE PURPOSE FROM PALMER COX, ESQ., OF HIS COPYRIGHTS, PATENTS, PATENT RIGHTS AND ORIGINAL "BROWNIE" DESIGNS.



## News Gleanings.

L. M. Lawless, Geneseo, Ill., has closed his store.

A. McNeal will go into the jewelry business in Kilgore, Ky.

H. L. Kohler, Lebanon, Pa., has sold his store to a New York party.

S. M. Widney, Tyrone, Pa., has removed to a new location in that town.

The stock of Fred Greenland, Conway, Kan., was closed recently by mortgage.

Charles E. Douglas, of Cassville, Wis. has opened a jewelry store in Elkport, Ia.

James J. Kelley, Bancroft, Ia., is advertising his business for sale, owing to ill health.

Beno Jacobson, Arcadia, Fla., has removed his jewelry store to another building.

Mr. Day, of Elgin, Ill., is to open a jewelry shop in the postoffice at Carpentersville, Ill.

George H. Dougherty has bought the jewelry store of R. H. Wilhermsdorfer, Ottumwa, Ia.

E. P. Culver, Iowa City, Ia., has left for Chester, Vt., where he has purchased a jewelry business.

W. P. Face has opened at 712 Penn St., Reading, Pa., a store and a suite of rooms for the sale of optical goods.

Davidow & Co., formerly of Wilkesbarre, Pa., will soon open a jewelry store at 126 Market St., Wilmington, Del.

W. Z. Andrews is back from Des Moines, Ia., where he has been in the interests of the W. F. Main Jewelry Co., Iowa City, Ia.

The new establishment of C. A. Havensstick, 333 Market St., Harrisburgh, Pa., is described by the local papers as a model optical store.

Capt. T. C. Parker is now comfortably located in his new jewelry store, in the Welles building, West Side Public Square, Wilkesbarre, Pa.

F. J. Stilson, W. R. Collins, and E. B. Stilson, Atlanta, Ga., have filed a petition for a charter incorporating them as the Stilson & Collins Jewelry Co.

John Bauerle and Clarence Helvey, partners as Bauerle & Helvey Hamilton, O., have dissolved partnership. Mr. Helvey will hereafter conduct the business.

The jewelry store of H. C. Parker Lincoln, Ill., was closed Wednesday afternoon by the sheriff under executions in favor of wholesale houses and local creditors.

Charles L. Dingler and William K. Robert, two bright and enterprising young men, have purchased the jewelry store at 824 Edgemont Ave., Chester, Pa., formerly run by Herman Zeigler.

Greenleaf & Crosby, Jacksonville, Fla., have closed for the season their branch store at the Hotel Royal Poinciana, Palm Beach, Fla., the southernmost railroad point in the United States.

Max Myerheim, Bay and Hogan Sts., Jacksonville, Fla., has filed a deed of

assignment. Eugene Oberdorfer, of Jacksonville, is the assignee. No statement of liabilities and assets has been filed.

The window of H. E. Hodgson's jewelry store, 23 Granby St., Norfolk, Va., was broken last Sunday night and \$50 worth of eyeglasses and about \$300 dollars worth of old coin of various nations stolen.

W. W. Mather, Washington, Pa., has purchased the stock of jewelry at C. M. Stauff's old stand, Charleroi, Pa., of Goddard, Hill & Co., Pittsburgh, and moved it to Belle Vernon, where he will open a store.

Solomon Speed, colored, in jail at Logansport, Ind., for robbing J. D. Taylor's jewelry store of \$600 worth of goods, and two other prisoners, broke jail a few nights ago by sawing out at the roof and lowering themselves to the ground by means of bed-ticking.

The Tillman Jewelry Co., Clarion, Ia., have incorporated with a capital stock of \$2,500 in single shares of \$25 to operate a retail jewelry store. The promoters are Sophia E. Buell, E. B. Tillson, E. V. Tillson, H. S. Buell and Geo. Tillson, all of Clarion.

G. M. Heiserman has purchased the fixtures in C. S. Sands' jewelry store, Albia, Ia., and has brought his own stock from Clarinda, Ia., to the former place. The Sands stock has been taken to Oskaloosa, where it will be under the management of Ben Sands.

### Buffalo.

On and after April 25th the office of Warner & Warner will be located at 329 Washington St.

Charles Kerr, of Silver Springs, is to move his jewelry business to Perry.

The destructive fire at Main and Division Sts. on the night of April 7th, damaged the business of the Buffalo Watch Co., 333 Main St., and of Joseph Roth, dealer in watchmakers' supplies, 289 Main St.

The item published last week to the effect that the Niagara Falls store of T. V. Dickinson is not affected by his failure, conveyed a wrong impression. It seems Mr. Dickinson's daughter is not running it under his name, but under her own. When she took the store it inventoried less than \$4,000, at prices that were paid for the stock; in addition she assumed \$1,400 debts. This transfer, Mr. Dickinson says, was the only way he could liquidate his indebtedness to her. The stock in the Buffalo store was sold by the sheriff and bought by the bank to secure judgments. Mr. Dickinson is helping the authorities in charge of his affairs to settle matters.

R., & L. M. Friedlander, 65-67 Nassau St., New York, are at present making a leader of some beautiful O. F. 14 kt. complete Elgin watches at exceptionally attractive prices. Full particulars can be obtained by communicating with the firm.

## PATENT paneled METAL CEILING Stamped Raised Panels.

ARTISTIC AND PERMANENT.

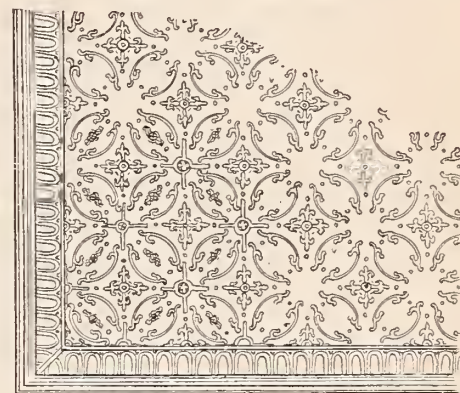

Easily applied in new buildings, and over old broken plaster or wood Ceilings. If interested in building or repairing, send stamp for Illustrated Catalogue, and state if CHURCH, HALL STORE, OFFICE, or SCHOOL Ceiling is wanted. Address

A. NORTHROP & CO., Pittsburg, Pa.

## NOTICE! TO MANUFACTURERS

A WELL-KNOWN Manufacturing House visiting the best retail Jewelry trade throughout the country, wishes to make arrangements with manufacturer of novelties in Gold Jewelry, to carry in connection with their line.

Address K.,

Care of Jeweler's Circular.

NEW! IMPROVED NEW!  
Adjustable "Eclipse" Eye Glasses.

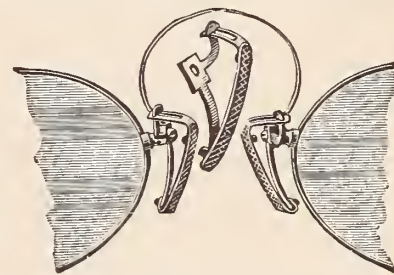

PATENT APPLIED FOR.

We claim this invention to be the only one which combines the advantages of both the adjustable and offset guards. We will furnish these frames or guards in either Zylonite or Cork.

WRITE FOR CIRCULAR.

JOHN SCHEIDIG & CO., SOLE AGENTS  
43 MAIDEN LANE. NEW YORK.

J. PRINCE,  
Jewelry Auctioneer,  
At liberty from January 1st, 1894. Retail  
Jewelers only. Address,  
Rooms 9 & 10, 137 BROADWAY  
N. Y. CITY.







## Special Notices.

Rates 75c. per insertion for notices not exceeding 5 lines (25 words); additional words 2 cents each. If answers are to be forwarded, postage stamps must be enclosed. Two insertions, 15 per cent. off, three insertions, 20 per cent. off; four insertions or more, 25 per cent. off. Payable strictly in advance. Display cards on this page will be charged at \$2.00 per inch for first insertion, subject to same discount as above for subsequent insertions.

Under the heading of **Situations Wanted** on this page advertisements will be inserted for **One Cent a Word**. This offer refers to **Situations Wanted only**. Payable strictly in advance. If answers are to be forwarded, postage must be enclosed.

## Situations Wanted.

Notices under this heading **ONLY** are charged at one cent a word, payable strictly in advance. If answer are to be forwarded, postage must be enclosed.

**WANTED, SITUATION**—Manager of a business for two years past. Do all branches of work—watchmaking, engraving, seal making, jobbing, selling, buying. Box 695, What Cheer, Ia.

**WANTED** by a first-class watchmaker, with an excellent equipment of tools, a place in a first-class jewelry establishment, New York or Brooklyn preferred. Samples of workmanship sent for inspection, if required. Address W. H., No. 7 Decatur St., Brooklyn, N. Y.

**SITUATION WANTED** as watch and clock maker; also jewelry repairer; age 21; speaks English and German; good references. Address A. Guenther, 875 Sixth Ave., New York.

**ENGRAVER, Ar.** Lettering in all its branches. Monograms, ciphers and ornamental work. Also capable of doing copper plate and die cutting for stationery trade. Open for engagement after May 1st. Address J. J. M., care THE JEWELERS' CIRCULAR.

**AN OPTICIAN AND WATCHMAKER.** About May 1. Charge of optical department in jewelry or optical store, or go on the road. E. T. Smith, 109 Cedar St., Corning, N. Y.

**FIRST-CLASS** practical lapper and polisher wants position; used to all kinds of best diamond mountings; capable of taking charge of polishing department; would go anywhere for good position. Address Practical, 7 Clifton Ave., Newark, N. J.

**WANTED AT ONCE**, by a young man of twenty-three a place to complete trade under a good man. Three years' experience at bench; can do ordinary hard solder and clock repairing; also salesman. Best of references. Address H. Bruns, 133 Main St., Columbia, S. C.

**WANTED.**—Position by thorough, practical watchmaker, of seventeen years' experience at the bench; full set of tools. First-class references. Address C., care of THE JEWELERS' CIRCULAR.

**SITUATION WANTED** by young man. Good watch and jewelry repairer. Owns tools and lathe. Best references. Address F. W. S., Box 342, Birmingham, Conn.

**SITUATION WANTED** by a young man. First-class watchmaker. Ten years European experience and six years in this country. Owns tools. Situation in Southern States or California preferred. Address Aug. Lindblad, 2562 Eighth Ave., New York City.

**YOUNG MAN** desiring to complete trade will act as clerk if desired. West preferred. Address F. H. Child, 404 N. Water St., Wichita, Kan.

**SITUATION WANTED** by practical watchmaker and plain engraver; does clock and jewelry repairing if necessary; best of habits and references; have full set of tools; can speak German. Address Reliable, care of THE JEWELERS' CIRCULAR, 517 Inter-Ocean Building, Chicago, Ill.

**POSITION** wanted as bookkeeper; able to superintend; present employers retiring from business. Address F., care of THE JEWELERS' CIRCULAR.

**POSITION** wanted as salesman by a young man of 21 who has been brought up in jewelry store; has fair knowledge of repairing; at best behind the counter; can play musical instruments; good credentials. Address P. O. Box 23, Littlestown, Pa.

**WORK WANTED FOR JEWELERS, SILVERSMITHS, ENGRAVERS, DESIGNERS, WATCHMAKERS, CASEMAKERS, TOOLMAKERS, ETC. ONLY WORKMEN WITH GOOD TESTIMONIALS FROM PREVIOUS EMPLOYERS ARE RECOMMENDED.**

ADDRESS,  
**JEWELERS' RELIEF ASSOCIATION,**  
11 MAIDEN LANE, N. Y.

## Help Wanted.

**WANTED.**—A salesman traveling through Southern States selling retail jewelry trade to take a side line. Address B., care of THE JEWELERS' CIRCULAR.

**WANTED, A WINDOW DRESSER.**—Professional preferred; although those having had a little experience, with good ideas, may apply. Permanent position guaranteed to capable party. Address Spartan, care of THE JEWELERS' CIRCULAR.

**OPTICIAN WANTED**—A retail jeweler eligibly located uptown in New York would let part of store to competent optician. For particulars address Jos. Friedlander & Bro., 21 John St., City.

**WANTED.**—Traveling salesmen in all parts of the United States to carry an illustrated pocket catalogue and price list of Grout's Excelsior Watch and Spec Signs and Watch Tools, Foot Wheels, Polishing Lathes, etc., for jewelers' use. Big money as a side line. Can be carried in the pocket. Every traveler should carry it. Write for agency. Excelsior Sign & Mfg. Co. L. S. Grout, manager, 56 State St., Chicago.

## To Let

**BROADWAY STORE** near the Post Office; desirable location; moderate rent; lease. Apply on premises, 2 Astor House.

**TO LET**—Part of office 15 Maiden Lane; steam heat, also burglar alarm. For particulars apply to Martin, Copeland & Co. 15 Maiden Lane, City

**TO LET**—Part of factory, with steam power. Center of jewelry district. Moderate rent. J. F. Newman, 19 John St.

**FINE OFFICE** for manufacturer's agent, 16 x 12 feet; vault and all conveniences. Champlain Building, cor. State and Madison Sts. Rent, \$25.00. Will take merchandise for rent. S. N. Clarkson, 182 State St., Chicago, Ill.

## Miscellaneous.

**I BUY JEWELRY STOCKS**—Manufacturers, jobbers and retailers desiring to dispose of surplus or entire stocks of diamonds, watches and jewelry can find quick cash buyer by addressing Stephen S. Harmon 134 East 96th St., New York City.

**PARTNER** with capital wanted by manufacturing jeweler. Must be a good salesman. Address O. K., care of THE JEWELERS' CIRCULAR.

## DEMAGNETIZING.

**PERFECT WORK**—Watch repairing in all its branches; all work warranted. Winslow & Penney, 608 Masonic Temple, Chicago.

**FOURTEEN karat gold solder** that will flow on eight karat work; makes a hard solder job a pleasure. With this solder there is no danger of melting low karat specs. No white joints on rings. It is just what you want. Sample by mail 25 cents. F. W. Hall, sterling Silver Novelties, Columbus Memorial Building, Chicago, Ill.

## For Sale.

**ATTENTION, Watch Case Makers and Jobbers.** Will sell, low, one circular and one straight-line engine turning lathe, in good condition. Charles Ferret, 180 Broadway.

**FOR SALE**—An old established jewelry store in a city of over 20,000 inhabitants near Boston. Inventory about \$6,000. Address "Snap," care of THE JEWELERS' CIRCULAR.

**JEWELRY STORE FOR SALE.**—I have made my pile and wish to retire from business. A good chance for someone to do as I have done. For particulars address C. H. R. Cheney, Stoneham, Mass.

**FOR SALE.**—Jeweler's safe; 4 ft. 7 in. high, 3 ft. wide. Burglar-proof chest, double combination lock. Price, \$100. Also three counter and outside showcases. J. C. Proudman, 307 Eighth Ave., New York City.

**FLAT MILLS AND FOOT PRESS** cheap—a bargain; also cutters. Address E. B. Hayden, 75 Nassau St., Room 14.

**JEWELRY BUSINESS FOR SALE.**—The undersigned as administratrix of the estate of Albert Townsend, deceased, wishes to sell the jewelry store lately carried on by said deceased.

This business was established about 20 years ago, and is well known and has a good repairing trade in connection.

The stock is well assorted and of a kind generally kept in a first-class store of the kind, the fixtures are also of the best.

The store is located in Matteawan, Town of Fishkill, N. Y., which has 13,000 inhabitants, and is the center of business for a large and wealthy farming country.

Terms cash. Call on or address Leila Townsend, Administratrix, Matteawan, Dutchess County, New York.

LEILA TOWNSEND, Administratrix.

**FOR SALE.**—Rare bargain. One of the best plating shops in Connecticut. Can control a good business. Address Plating, Box 656, Hartford, Conn.

## FOR SALE—TOWER CLOCK.

Made by the Howard Clock Co.; dial trains, connecting rods and hands for two 3-foot dials; suitable for store front, church public building; in use only nine months; will be sold cheap.

**HENRY ABBOTT,**

No. 2 Maiden Lane, New York.

**\$5,000** for long established retail Jewelry business in city of 100,000 inhabitants;

**YEARLY PROFIT ABOVE EXPENSE, \$3,500.** Can be greatly increased by additional capital if desired.

Satisfactory reasons for selling given to parties with necessary cash capital. Address,

CHANCE care of THE JEWELERS' CIRCULAR.

## FOR SALE.

The Old Established Jewelry Business of G. A. SCHULTZ (Dec'd), is for sale at a great bargain. New fixtures throughout; good location. Address

**HELENA SCHULTZ, Ex'trix,**  
Corner 7th & Market Streets, LOUISVILLE, KY.

## TO LET! PART OF STORE.

**Chas. Jacques Clock Co.**

22 CORTLANDT STREET, NEW YORK.

## Cheap, Bright Offices To Let

singly or in suites, in the handsome new buildings,

14 and 45 MAIDEN LANE.

Rents \$350 up; elevator, steam heat, electric lights, etc. E. A. CRUIKSHANK & CO., 176 Broadway.

## TO LET!

**ENTIRE SECOND FLOOR, WITH STEAM POWER, IN THE JEWELRY MANUFACTURING BUILDING, REAR OF**

**17 JOHN STREET,**

Apply to ENGINEER on the premises.

## TO LET.

**FACTORY ROOM WITH POWER.**

Elevators, Steam Heat, Watchman, Automatic Fire Sprinklers and good light. Cor. York and Washington Streets, Brooklyn—near the Bridge, within 12 minutes of N. Y. City Hall. For information, apply at Factory, or 198 Broadway, N. Y.

**Ketcham & McDougall.**



**Springfield, Mass.**

Mrs. A. F. Springer, of Hartford, has been visiting her old home in this city for the past week.

Charles Rogers, the optician, entertained the inmates of the almshouse one evening last week with a stereopticon exhibition of the World's Fair, using views secured by himself while in Chicago.

Mr. and Mrs. F. A. Hubbard have been chosen members of the reception committee for the banquet of the Sons and Daughters

**ENTIRELY NEW AND EXCLUSIVE LINES**

OF HIGH GRADE

**Sterling Silver Novelties.**



**Bachrach & Freedman,**

Nos. 1 & 3 Union Square,

NEW YORK.

of Vermont, which is to be held in Masonic hall next Thursday evening.

H. P. Howard, of the Towle Mfg. Co.; J. A. Coddling, Coddling Bros. & Heilborn; W. M. Kaas, A. J. Hedges & Co., and Mr. Hempel, Sandland, Capron & Co., were in Springfield during the past week.

Mrs. P. J. Walter, widow of the deceased jeweler, is having trouble in securing the amount of an accident insurance policy which her husband had on his life. It will be remembered that Mr. Walter was killed about a year ago by the accidental discharge of a gun which he was handling. He carried an accident policy for \$5,000 with the Atlas Co., of Boston. The company refused to settle, claiming that the policy was not good for its face value and that the risk was a lower one than Mr. Walter could have obtained had not the agent misrepresented the matter. At the Boston office it was said that Mr. Walter was not a jeweler, as stated in the policy, inasmuch as he did not carry a stock of jewelry above a certain figure. More than this, one of the agents of the company visited Mrs. Walter and insinuated that her husband had committed

suicide. Mrs. Walter has now entered suit.

**The Eglinton Jewels.**

THE recent sale in London of the celebrated Eglinton family jewels drew a large crowd. There were only fourteen lots, but they were all extremely handsome and interesting. The celebrated black pearl necklace was bought by Sir J. Blundell Maple for £3,500. Some people thought this a great price, but those who understand these things are of opinion that, as the pearls cannot be matched, their value is limitless. They are of remarkable size and beauty and are set in a cluster of brilliants connected with chain pattern links of diamonds.

There was a splendid diamond star, with a very large stone in the centre, and four smaller ones, forming a head ornament; four or five handsome bracelets, a pair of large pear-shaped earrings, a beautiful blue enamelled necklace, and the famous necklace, earrings and brooch which formerly belonged to Mary Queen of Scots. These jewels, together with a picture of Holbein, which now hangs in Eglinton Castle, were given by Queen Mary to Mary Seton, who was one of the well known "Queen's Marys." The picture and necklace were brought into the Eglinton family by the marriage of a Montgomery (the family name of the Eglintons) with the heir of the Setons. They were found in the muniment room of Eglinton Castle.

These family relics were sold for the late Earl's daughters. Having no son, he left them between his four daughters, but as they were of such very unequal value it was impossible to divide them satisfactorily, so they had to be sold. The present Earl is the uncle of these ladies, having succeeded his brother in 1892. He is about forty-six and was in the Grenadier Guards. Both he and his brother were the sons of the Earl who held the wonderful mediæval tournament in 1839 at his castle in Scotland, at which the Duchess of Somerset, then Lady Seymour, was declared the Queen of Beauty. She was one of the three beautiful and celebrated sisters, daughters of Tom Sheridan.

**TIME OF PRESENTMENT FOR PAYMENT OF NOTES**

Under laws 1893, providing that every Saturday from 12 o'clock noon till 12 o'clock at night, as regards the presentment of notes for payment, shall be a half holiday; that such notes shall be payable and presentable for acceptance and payment on the business day succeeding such half holiday; but that every Saturday shall, for the holding of court, and the transaction of any business authorized by law, be deemed a business day,—notes maturing on Sunday are payable on Monday. *Hitchcock v. Hogan, (Supreme Court of Michigan).*

Silver seals for the library table, and as watch fobs are new



**Great Reduction in Watch Glasses.**

To make room for a large Stock of W. B. & C. Watch Glasses, which is the only kind we are going to keep, we will sell out our Stock of Blue Label Glasses at following prices:

GENEVAS, - - - -	at \$1.40 per gr.
MI CONCAVES, - - - -	1.80 " 6% for Cash.
PAT. GENEVAS, - - - -	3.40 "

**NOW IS THE TIME TO STOCK UP.**

We carry a full stock of Tools and Materials at the lowest prices. And also give strict and prompt attention to repair work of all kinds for the trade, thus enabling our customers to save time, trouble and Money by concentrating their orders.

**FISHER & SONS, 63 NASSAU ST., New York.**

**REMOVAL                      REMOVAL                      REMOVAL**

**TO                                      TO                                      TO**

**45 MAIDEN LANE, N. Y.    45 MAIDEN LANE, N. Y.    45 MAIDEN LANE, N. Y.**

**Leon Hirsch,                      IMPORTER OF                      Watches.**



**The Latest Patents.**

ISSUE OF APRIL 10, 1894.

**517,838. CLOCK STRIKING APPARATUS.** CHAS. D. BROWN, Ames, Iowa.—Filed June 19, 1893. Serial No. 478,187. (No model.)

The combination with an ordinary clock housing, provided with a main shaft, of a pin secured to said shaft, a mutilated ratchet working upon said shaft and against said pin, and provided with an upwardly extending cam provided with the shoulder adapted to

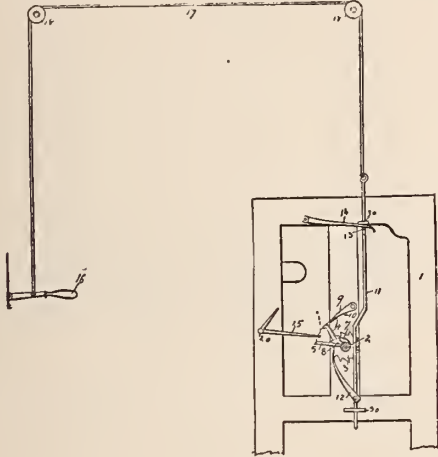

receive said pin, an extending arm secured to said ratchet, said ratchet riding loosely upon said shaft, and an arm provided with a pawl for operating said mutilated ratchet, said extending arm being adapted to operate the gong lever.

**517,882. WATCH.** JOHN W. NUNAMAKER, Chicago, Ill., assignor of one-fourth to Harvey L. Hopkins, same place.—Filed June 20, 1893. Serial No. 478,224. (No model.)

In an escapement watch, a balance wheel, in combination with an escapement wheel constructed and

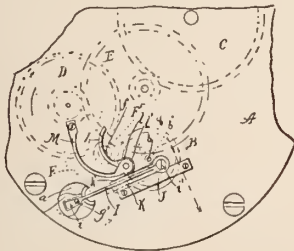

adapted to apply power directly to the former, a gear-train connecting the escapement wheel with the main spring drum, an escapement lever provided with a rack segment engaging with the balance pinion, and a spring connected to said lever to reverse its motion by direct action thereon.

**517,933. WATCHCASE-PENDANT.** WILLIS S.

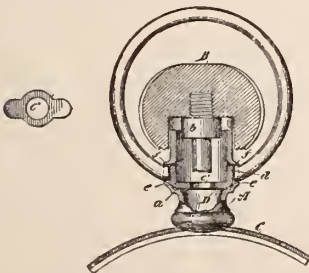

RICHARDSON, Newark, N. J., assignor to the Newark Watch Case Material Co., same place. Filed July 10, 1893. Serial No. 480,005. (No model.)

The combination with a watchcase pendant formed with openings in the sides thereof, of a collar fitted therein and provided with bearings adapted to close the inner sides of said openings, and a bow, the ends of which fit in said openings and against said bearings.

**517,970. VEIL-CLASP.** HELEN L. ALEXANDER, Washington, D. C. Filed Nov. 27, 1893. Serial No. 492,129. (No model.)

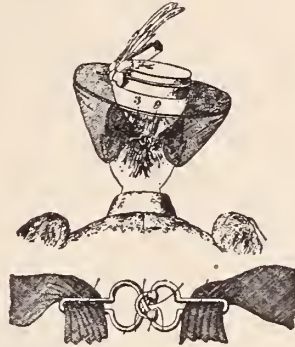

The herein described clasp, the same comprising the locking member 1 adapted at its outer end to engage with a veil or the like, and at its inner end having opposite curved spring arm crossing each other and provided at their extremities with guard-balls, and the loop member adapted at its outer end to engage with a veil or the like, and in advance of the same provided with an enlarged eye having at its front side a smaller eye or offset, between which and said offset a narrow neck or entrance is formed.

**518,036. INKSTAND.** WALTER HUBBARD, Meriden, Conn., assignor to the Bradley & Hubbard Mfg. Co., same place. Filed Feb. 17, 1894. Serial No. 500,522. (No model.)

**518,099. MECHANISM FOR MAKING SPECTACLE-BOWS.** FREDERIC ECAUBERT, Brooklyn, N. Y. Filed May 13, 1892. Serial No. 432,849. (No model.)

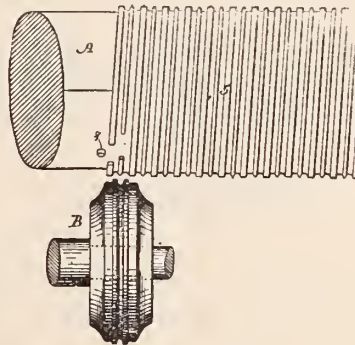

The combination with a pressure roller of a form mandrel and means for causing the wire to pass around the mandrel and between the mandrel and the roller at the speed of the mandrel, there being recesses at intervals in the form mandrel whereby the wire is shaped longitudinally about the form mandrel and reduced transversely at intervals.

**518,104. STEREOPTICON.** EDMUND HUDSON, Washington, D. C.—Filed July 21, 1893. Serial No. 481,099. (No model.)

**518,116. MUSTACHE-GUARD FOR SPOONS.**

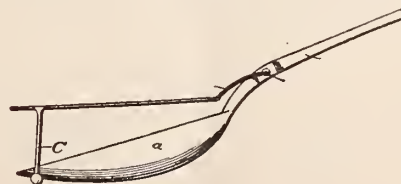

CARL A. QUENTELL, New Orleans, La.—Filed Jan. 9, 1894. Serial No. 496,240. (No model.)

A spoon carrying a guard flexibly connected above the bowl and having a pendant adapted to raise the guard from the bowl.

**518,135. ELECTROLYTIC APPARATUS.** HAMILTON Y. CASTNER, London, England.—Filed June 8, 1893. Serial No. 476,939. (No model.)

**DESIGN 23,170. HANDLE FOR SPOONS, &c.** GEORGE A. MUELLER, Concord, N. H., assignor

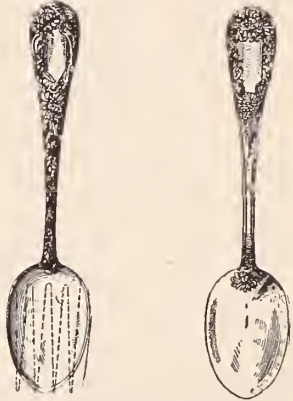

to William B. Durgin, same place.—Filed Jan. 11, 1894.—Serial No. 496,545. Term of patent 7 years.

**DESIGN 23,171. HANDLE FOR SPOONS, &c.** JOHN CLULEE, Wallingford, Conn., assignor to Simpson, Hall, Miller & Co., same place.—Filed



March 12, 1894. Serial No. 503,367. Term of patent 3½ years.

**DESIGN 23,172. HANDLE FOR SPOONS, &c.,** GEORGE ROCKWELL, Meriden, assignor to



Rogers & Bro., Waterbury, Conn.—Filed March 12, 1894. Serial No. 503,369. Term of patent 7 years.

**DESIGN 23,173. FORK-SCRAPER.** WM. JACOBS



OSTERMAN, Richmond, Va.—Filed Feb. 6, 1894. Serial No. 499,302. Term of patent 3½ years.

**DESIGN 23,181. CANDELABRUM-PEDESTAL.** CHARLES C. WIENTGE, Providence, R. I., assignor

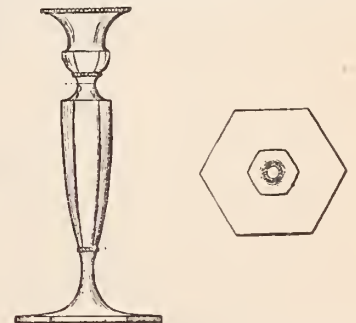

to the Howard Sterling Co., same place.—Filed March 8, 1894. Serial No. 502,909. Term of patent 7 years.



DESIGN 23,182. PRONGED STANDARD. FREDERICK RATCLIFF, New Bedford, Mass.,

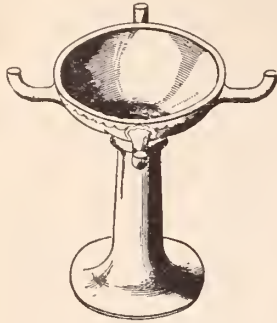

assignor to the Pairpoint Mfg. Co., same place. Filed Oct. 5, 1893. Serial No. 487,292. Term of patent 7 years.

DESIGN 23,183 and 23,184. PICTURE FRAMES. ROBERT GOLDE, Brooklyn, N. Y., assignor to the Royal Metal Mfg. Co., of New York.—Filed Feb. 13, 1894. Serial Nos. 499,995 and 499,997. Term of patents 3½ years.

DESIGN 23,191. BOX. ALBERT JAMES ROSCOF, New Bedford, Mass., assignor to the Pairpoint Manufacturing Company, same place.—Filed Feb.

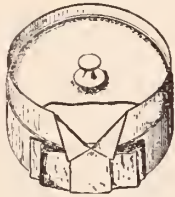

15, 1894. Serial No. 500,310. Term of patent 3½ years.

TRADEMARK 24,481. WATCHES AND WATCH-CASES. THEOPHILUS ZURBRUGG, Riverside, N. J.—Filed Feb. 6, 1894.



**H. H. HEINRICH,**  
14 John St., N. Y.  
MARINE  
**Chronometers**

for Rent and Sale.  
**Large Stock on Hand.**  
Springing, Readjusting and  
Repairing for the trade.

Easy Terms. Send for Price List.

**FOR JEWELERS' USE.**

G. A. Kleemann's Patent Improved Student Lamp.

C. A. Trade Mark.

**THE GERMAN AMERICAN.**

It preserves all the improvements which have made the St. Germain Student Lamp so acceptable to Watch-makers and Mechanical Jewelers, but is a much larger Lamp, fit d with a nine inch shade and its new large burner—far superior to that of the St. Germain—gives a light nearly double in brilliancy.

Steady wh to light, perfect combustion, without much heat, safe against explosion.

Will last a lifetime. Wick easily adjusted. Illustrated circular free.

**HINRICH'S & CO.,**  
29, 31 & 33 PARK PLACE,  
NEW YORK CITY.



**THE GLOBE PUZZLE.**

**The LATEST Advertising Novelty.** You can positively make from \$20 TO \$50 in cash in your own town with little effort, and procure a large amount of advertising for your own business, free. No risk to run, no investment to make until success is assured. Write quick and procure samples and full information and exclusive control for your town.

**D. E. ORVIS & CO.,**

**PERFECTION.**

*Essential feature.* The word "PERFECTION." Used since Feb. 1, 1894.

TRADEMARK 24,482. WATCHES AND WATCH-CASES. THEOPHILUS ZURBRUGG, Riverside, N. J.—Filed Feb. 6, 1894.

**PREMIER.**

*Essential feature.* The word "PREMIER." Used since April 1, 1890.

TRADEMARK 24,483. WATCHES AND WATCH-CASES. THEOPHILUS ZURBRUGG, Riverside, N. J.—Filed Feb. 6, 1894.

**PRIVATEER**

*Essential feature.*—The work "PRIVATEER." Used since January 14, 1892.

TRADEMARK 24,484. WATCHES AND WATCH-CASES. THEOPHILUS ZURBRUGG, Riverside, N. J.—Filed Feb. 6, 1894.

**PROTECTOR**

*Essential feature.*—The word "PROTECTOR." Used since February 1, 1894.

TRADEMARK 24,485. WATCHES AND WATCH-CASES. THEOPHILUS ZURBRUGG, Riverside, N. J.—Filed Feb. 6, 1894.

**PALATINE**

*Essential feature.*—The word "PALATINE." Used since February 1, 1894.

**Expired Patents.**

EXPIRED APRIL 10, 1894; GRANTED APRIL 10, 1877.

189,301. FOUNTAIN-PENS. A. T. CROSS, Providence, R. I. Filed June 12, 1876.

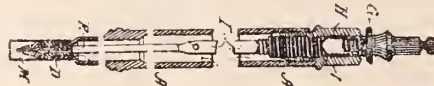

The needle D, tube M, and pen P, in combination with the ink-conveying tube N, of greater diameter than the tube M.



183,307. ROLLER-ABSTRACTORS FOR WATCHES. B. FRESE, Chicago, Ill. Filed May 29, 1876.

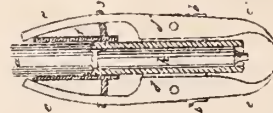

The independently-pivoted jaws e<sup>1</sup>, having circular grooves in the faces of their turned-in ends, in combination with the extensions e e<sup>2</sup> and cross-bar g, for closing the jaws simultaneously, and grasping the object uniformly on all sides.

189,511. EYEGLASSES. JOHN S. SPENCER, New York, N. Y. Filed June 7, 1876.



*Brief.*—Suspending-hook attached to and forming part of eyeglass frame.

ISSUE OF APRIL 3, 1894. (Omitted last week.)

517,546. COMBINED MATCH BOX AND CIGAR TIP CUTTER. THEODORE W. FOSTER, Providence, R. I.—Filed Nov. 11, 1893. Serial No. 490,669. (No model.)

In a pocket match box, the combination with the hollow body portion having the open end, and the

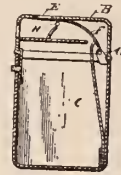

hollow cover hinged to the body portion at one edge and having its sides and edges adapted to close against the sides and edges of the body portion respectively to inclose matches projecting from the box and having a cigar tip opening in its top face, with a guide within the cover and in proximity to the inner side of its top, of a knife working between the guide and top of the cover to open and close the cigar tip opening, and a direct hinge connection between the knife and body of the box at a point forward of the cover hinge, whereby the knife is inclosed within and held against lateral movement by the walls of the cover.

**Canada and the Provinces.**

William F. Doll, Winnipeg, Man., has invented a ring gauge and patented it in United States and Canada.

John Wanless & Co., manufacturing jewelers and diamond merchants, Toronto, Ont., will soon move into their new premises, 168 Yonge St. When completed the store will be one of the finest in the Dominion.

Charles M. Henderson & Co. sold on April 13th, at their rooms, 219 Yonge St., Toronto, the balance of Kent Bros.' stock, comprising 65 watches, show cases, jewelers' tools, office desks, valuable safe, cost \$500, with a host of other stock.

James Ryrie, the Toronto jeweler, and Mrs. Ryrie left for Amsterdam last Monday. Mr. Ryrie goes over to make his selection of the year's supply of diamonds. The trip will all o include a visit to the leading art and manufacturing centers of England, France and Italy.

The Customs returns for the port of Toronto for 1893 show the total imports in diamonds to be \$124,639, imported from England, United States, and Holland, as follows: Value of diamonds imported from London, England, \$114,372; United States, \$4,475; Amsterdam, Holland, \$5,792.

Christopher Moody, jeweler, Hamilton, Ont., was sentenced to three months in the Central prison, last week, for assaulting and doing bodily harm to the Rev. E. M. Bland, rector of Christ Church Cathedral. Moody and the Rev. Mr. Bland had some words on the public street, over a lawsuit, and Moody struck Mr. Bland, giving him a black eye and cutting open his cheek.

Spott & Spott, Richmond, Va., who recently settled with their creditors, have confessed judgment for \$125.





# L. STRAUS & SONS,



IMPORTERS AND MANUFACTURERS,

China, Pottery and Glassware, 42, 44, 46 & 48 Warren St. and 116 Chambers St., N. Y.  
PARIS, CARLSBAD, RUDOLSTADT, LIMOGES, STEINSONAU.

**WOOD & HUGHES,**  
STERLING SILVERWARE MANUFACTURERS  
New York Agents for the Derby Silver Co.'s  
FINE QUADRUPLE PLATED WARE,  
No. 16 JOHN STREET, NEW YORK.  
206 Kearney St., San Francisco, Cal.  
HASKELL & MUEGGE, Agents.



## IRONS & RUSSELL,

(SUCCESSORS TO CHARLES F. IRONS.)

MANUFACTURERS OF  
SOLID GOLD **EMBLEMS** ROLL PLATE  
PINS, CHARMS AND SOLID GOLD RINGS.



102 Friendship Street, - - Providence, R. I.

# The "Bryant" Rings.

Are widely advertised and will sell  
when anything will, therefore  
every Retail Jeweler should buy them.

IF NOT CALLED UPON BY OUR TRAVELERS  
ORDER DIRECT FROM

**M. B. BRYANT & CO.,** 10 MAIDEN LANE, N. Y.  
OLDEST RING MAKERS IN AMERICA.



ESTABLISHED 1870.

**J. L. CLARK,**  
SWEEP SMELTER AND REFINER OF GOLD AND SILVER.  
Buys every kind of Gold and Silverware, Jewelry, Watches and Platinum. Full market value paid.

No. 724 Filbert Street, Philadelphia, Pa.  
SEND BY EXPRESS or Registered Mail. If my price is not satisfactory, I will return all articles.

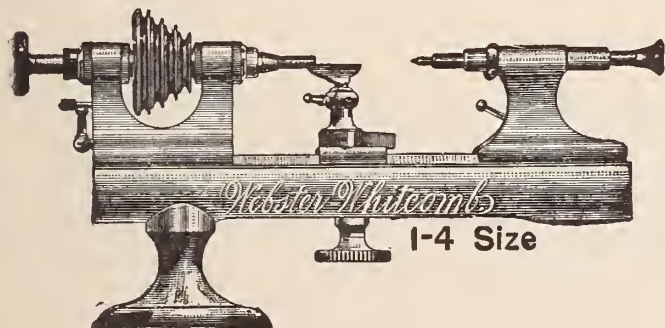

STRONGEST GUARANTEES.

Quality  
Maintained.  
Prices to  
Suit the Times.

Ask for our New  
Prices and  
Terms for 1894.

**American Watch Tool Company,**  
Chymistry Dist., Waltham, Mass., Stoney Batter Works.

**Paul Jeanne,** EIGHTEENTH STREET and 4<sup>TH</sup> AVE., N. Y.  
(Bradley Building.)  
MANUFACTURER OF  
FINE DIAMOND JEWELRY.

**VICTOR.** SIMPLEST FEED. ALWAYS THE SAME.  
GUARANTEED FOR ONE YEAR.

**THE VICTOR FOUNTAIN PEN**  
(Pat. Feb. 4, 1890.)

**THE BOSTON PEN CO.,**  
N. C. Whitaker & Co., Proprietors.  
363 Washington Street, Boston, Mass.,  
Manufacturers of finest quality  
TORTOISE : SHELL : AND : HORN : GOODS  
in every variety. Also Aluminum Hair Pins.  
Send for illustrated Pen Price List No. 1.

**WANTED BY...**  
**E. KIRSTEIN'S SONS CO.,**  
**ROCHESTER, N. Y.**  
**Opticians Of**

the country to send their PRESCRIPTIONS to them and receive prompt and satisfactory returns.

P. S.—Send for new Rx. List.



# FERDINAND BING & Co.,

106 GRAND ST., N. Y.

—NEW DESIGNS IN—

China Clocks and Gilt Bronze Sets, Fine Painted Dresden Goods in  
Vases, Cups and Saucers, and Plates; Cararra Marble Statuary,  
French Cabinets and other Fancy Furniture.

## Rich Cut Glass

AND

## DECORATED ART WARES.



Mt. Washington Glass Co.,

New Bedford, Mass.

RICH DISPLAY OF GOODS AT

New York Store: 46 Murray St.

When you visit Chicago do not fail to inspect our full line of goods at the new store of Pairpoint Mfg. Co., 224 Wabash Avenue.

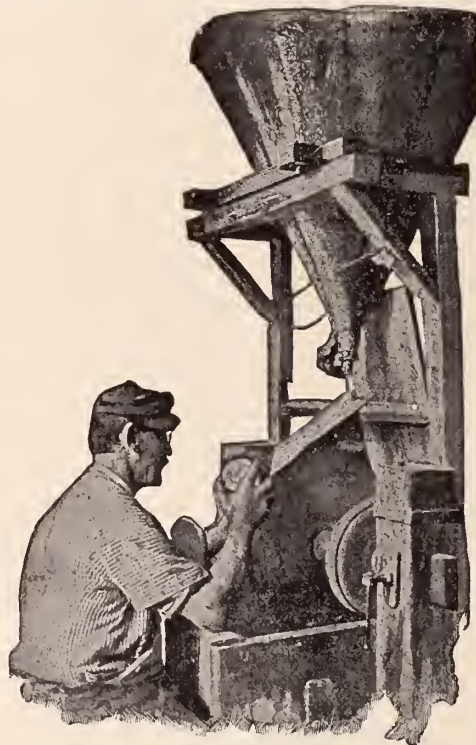

GLASS CUTTER AT WORK.



61 Hanover Street, Boston, Mass.

Sales made for Jewelers only in their established places of business. Can give best references of any auctioneers in America.

All communications strictly confidential.

# CHARLES AHRENFELDT & SON

50, 52 & 54 Murray Street, New York.

.... IMPORTERS OF ....

# China, Glass AND Bric-a-Brac,

ESPECIALLY ADAPTED TO THE JEWELRY TRADE.





### The Rambler's Notes.

WHAT THE RAMBLER SAW AND HEARD AMONG THE DEALERS IN ART POTTERY, CUT GLASS, BRONZES, ETC.

HIGH HONORS FOR  
POUYAT CHINA.

**H**ANFORD LIND-SAY, 56 Murray St., New York, the New York agent of the Société La Céramique, J. Pouyat, Limoges, France, has received word that M. Leon Dubrille, the president of the company, has been decorated by the French Government with the cross of the *Legion d'Honneur* in recognition of the magnificent display which this company made at the World's Columbian Exposition, Chicago. Owing to a difficulty with the management in relation to the judges, none of the exhibitors in the French section at the Fair competed for awards; the French Government has therefore taken this means to show its appreciation of those firms who by their creditable exhibits deserved honor. A full description of the Pouyat exhibit appeared in THE CIRCULAR of July 5th, 1893.

FINE JEWEL  
GLASS.

**I**N the new assortment of jewel glass which Lazarus, Rosenfeld & Lehman, 60 Murray St., New York, have added to the beautiful line previously described in this column is a large assortment of bonbonnières in large, medium and small sizes, which have in addition to the gold, a fine enameled figure decoration. Another line in which a new and rich variety is shown contains flower holders, violet and bouquet vases and rose bowls, the last named being shown in various shapes and sizes. A heavy gold and floral decoration ornaments this line. Among the entirely new additions are the trinket sets. There is also an assortment of very rich cologne bottles and petit boxes covered with matt gold and decorated à la Coalport with studded turquoises.

FINE CHINA FOR  
DECORATION.

**O**NE of the largest stocks of fine white china for decorating purposes, to be found in the Metropolis, is to be seen in the French department

of Bawo & Dotter, 30 Barclay St., New York. This stock, which includes Limoges, Bavarian, Saxon and Doulton china, contains everything in the way of art pottery, table sets and novelties, cabinet ornaments and all the other china specialties handled by the jewelry and fancy goods trade. In the Limoges plates and table sets and novelties isto be seen a full line in the Trocadero, one of this firm's latest and most popular shapes. Other lines deserving mention are the plates with openwork borders, the porcelain cane and umbrella heads, and the many varieties of individual sugars and creams. Among the after dinner coffee cups are some beautiful flower shapes, having leaf shaped saucers to correspond.

A FORERUNNER OF A  
FINE LINE.

**L**EVY, DREYFUS & CO. have received the first consignment of their new Limoges novelties, which is now to be seen at their warerooms, 9 & 11 Maiden Lane, New York. If this lot may be taken as a criterion, the stock of Limoges china which this firm will show will be a magnificent one, larger and richer than any they have ever before carried. Fish, game, ice cream, chocolate, and tête-à-tête sets abound, in all the latest colors and decorations. A particularly fine lot of dainty individual sugars and cream are shown together with a large and rich assortment of cups of all descriptions, in tea, coffee, after dinner, bouillon and other sizes. The decorations are varied, some with cupid and other panels, some flowers, others gold scroll work, while a variety of white or dark blue has incrustated gold borders. They also show many pretty Empire effects in blue, green and pink.

THE RAMBLER.

Collecting china and porcelain is one of Queen Victoria's chief hobbies. The collections of Her Majesty consist entirely of objects from Sèvres. Windsor is full of these precious porcelains and they adorn all her residences. The Queen is an excellent connoisseur. She does not admit the public to inspect her collection, but anyone who is enough of a connoisseur to appreciate this art may be admitted to Windsor.

### Della Robbia Pottery.

(Pottery Gazette, LonCon.)

**T**HE revival of an industry very closely allied to the Italian pottery of the Middle Ages, is an event of the greatest interest to ceramic art. The company formed under this title comprises the names of celebrated painters, as well as other gentlemen of critical taste, which is a sure indication that only the purest art work will be aimed at. This restoration of a lost link in pottery serves to bring to our mind the exquisitely beautiful work of the great potters of that age, foremost among whom was Luca della Robbia. In the present instance, the promoters of this new industry attach the highest importance to a radical return to hand-labor, and the enjoyment which should accompany that method of usefulness as contrasted with the non-artistic and baneful influence of the steam-engine and the multifarious mechanical appliances of every kind, which are producing thousands of articles without any felicity to the maker or satisfaction to the consumers; the steam-engine turns out far more articles than are really wanted, and at a rate much faster than human judgment can control, and void of the care which is necessary to make them serviceable and interesting.

Della Robbia pottery was first introduced into Italy in the early part of the fifteenth century; at the same time Italy may be considered to have obtained the elementary principles of the processes which she cultivated with such distinguished success during the fifteenth century; partly from the fictile productions of the Saracens or Moors, as the Arabs of Europe were called, and in part also from the Byzantine Greeks.

Early in the sixth century the Moors conquered the island of Sicily, and later on effected a landing on the main land; afterwards the island of Majorca became a stronghold of this peculiar people, who, though of a most warlike temperament, systematically carried on their characteristic ceramic manufactures with the greatest vigor. Early in the twelfth century the Italians, after a fierce and protracted struggle, regained possession of the island, and they carried, amongst other spoils, to their native cities specimens of rich Moorish pottery. Fictile plates, known as "baccini,"



**The Connoisseur.**

*(Continued from page 39.)*

are said to have been incrustated in the walls of the churches of Pisa and other parts of Italy; it is certain that the most ancient edifices still retain examples of these wall-plates, which are apparently of Moorish origin. The employment by the Moors of their enameled tiles for the decoration of the walls of their mosques would naturally suggest itself to the victorious Italians a similar treatment of the spoils of the conquered Saracens. In addition to the spoils of the Majorcans and the works of the Italo-Moors in Apulia, and of their brethren in Sicily, other fictile productions would appear at an early period in Italy in consequence of the gradual recovery of Spain from the Moorish invaders. The conquered Hispano-Moors wandered into Italy, whither they carried with them their potter's art. So also, without doubt, the never-absolutely-lost art of the ancient potters would travel to the congenial soil of Italy from Byzantium, as soon as there would appear the slightest prospect of its receiving patronage. In whatever degree Italian pottery may have been indebted to the Moors for the brilliant prismatic coloring introduced by that remarkable people, the revival of the ceramic art in Italy received a most powerful impulse from the operations of the Byzantine Greeks.

In the thirteenth century Italian pottery

attained a distinctive character of its own; the course of the succeeding century witnessed a progressive advance on former times. Under the Lords of Pesaro the manufacture assumed a more decorative aspect and the peculiar characteristics of the works of the next two centuries may be considered to have been determined. A new process at this period was developed upon which the subsequent ceramic operations of Italy were based. The red or other comparatively coarse and dark-colored clay which formed the body was first fired, and then by immersion it was covered with a thin coating of a glaze formed of oxides of lead and tin, and of a very white earth procured from the territory of Siena, after which the ware was again placed in the oven to receive its final firing. As the enamel was required harder and whiter so the proportion of tin was increased. The overlaying of an opaque white glaze on a colored body of a totally different texture, formed a process altogether new, and this may be regarded as the basis of the celebrated and unique majolicas of Italy:

Luca della Robbia was born in the city of Florence about the year 1400, and his life was prolonged until 1481. He first commenced his artistic career under Leonardo, a goldsmith of Florence, who enjoyed a deservedly high reputation. Robbia soon relinquished the profession of a goldsmith and devoted himself, in the first place, to sculpture in stone

and afterwards to modeling in clay. After countless experiments he arrived at the conclusion that an almost endless durability might be imparted to his figures in clay by overlaying them with a thick glaze of tin combined with other mineral substances. About the year 1438, della Robbia discovered an opaque white, highly lustrous, stanniferous enamel, which he was the first of his countrymen to apply to pottery. His earliest works are in white on a blue ground; but he subsequently introduced green, maroon, yellow and violet. He appears to have used these colors very sparingly, and to have retained his preference for white and blue. The works of Luca della Robbia, distinguished invariably by their simplicity and purity of style, consist of madonnas and Scripture subjects with architectural ornaments and glazed tiles. Luca della Robbia was succeeded by his nephew, Andrea, who had four sons, with the survivor of whom the productions of della Robbia ware may be said to have passed away.

Mr. Conrad Dressler, the initiator of the movement, and Mr. Harold Rathbone, are putting forth their utmost efforts in furtherance of the work which they have adopted "for the love of it," and we trust their labors may be crowned with the success which such work merits.

The truths a man carries about with him are his tools.—O. W. Holmes.

**Chrysanthemum.**

WE BEG TO ANNOUNCE THE EARLY APPEARANCE OF THE GREATEST EFFORT IN SPOONS AND FORKS, THE

**Chrysanthemum,**

(DESIGN PATENT PENDING).

FOR A YEAR THE MOST EXPERT DESIGNERS AND DIE-CUTTERS HAVE BEEN ENGAGED ON THE RICHEST AND MOST EXPENSIVE SPOON AND FORK DIES EVER PRODUCED. WE BELIEVE IT WILL BE TO YOUR ADVANTAGE TO INSPECT THE

**Chrysanthemum**

PATTERN BEFORE RENEWING YOUR STOCK OF SILVER.

PATTERN IS NOW IN PROCESS OF ILLUSTRATION.

WM B. DURGIN,  
CONCORD, N. H.



WHITE'S EYE SHADE. **W. B. WHITE & SON**  
MANUFACTURERS OF  
Spectacle and Eye Glass  
CASES

90 SOUTH STREET, BOSTON.

Special Cases made to order for Optical Trade, Cases for Trial Lenses, Opera Glasses recovered, etc. Chatelaine Spectacle Cases, Metal Bound Leather Cases for combs, scissors, etc. Over forty kinds of cases manufactured.

**SPECIAL** IN THE JEWELERS' CIRCULAR  
**NOTICES**  
Produce the results desired.

**Belts** AND Buckles. Send for Samples.

Elegant designs, Prices as low as the lowest. Hair Pins, Link Buttons, Ladies' Combination Shirt Waist Sets and all the latest in STERLING SILVER NOVELTIES.

MANUFACTURED BY  
**CODDING BROS. & HEILBORN.**

North Attleboro, Mass.  
Chicago office, Buck & Hall, 103 State St., Rm. 802.  
New York office, C. A. Vanderbilt, 178 B'way



# MATTERS IN JEWELRY STOREKEEPING.

That this department shall prove mutually beneficial to our readers, it is desirable that the members of the trade generally communicate with THE CIRCULAR regarding any advantageous device or plan they are utilizing in the conduction of their business.

## The Advantages of Metal Ceilings.

**A.** NORTHROP & CO., Pittsburgh, Pa., are doing some fine work in sheet metal ceilings. They are pioneers in the business and offer a neat finish in designs to suit all classes of buildings, and rooms of all shapes and sizes. They have a handsome deep stamped panel in two sizes, which makes a very rich panel ceiling, and have just brought out a new shallow panel which is shown in their advertisement in this paper. They have some good contracts on hand, and solicit correspondence from any who have ceilings needing repair, or are putting up new buildings.

The metal ceiling proves economical, being fire-proof and most durable, and can be put on over old plaster, making a tight finish as they do the work.

## A Good "Local."

THE following is an ingeniously worded local, which appeared in the *News*, Bangor, Me.:

IT WAS POOR ADVICE.

A jeweler once told Mark Twain to hang a monkey wrench on the safety valve to prevent his watch from gaining time. That, no doubt, was the very best advice that the "ex-engineer jeweler" could give. But if Mark could have shown his watch to W. M. Farrington, the Main St. jeweler, he would have received much better advice. If your watch or clock gets out of order do not take it to a botch workman, but carry it to Farrington's in Burr block and have it repaired by an experienced jeweler.

## Pricers in a Jewelry Store.

**A** YOUNG man apparently in good circumstances walked into a jewelry store on the Bowery one evening, took a good sized diamond ring from his finger, and, laying it on the counter, said to the clerk:

"How much will you give me for this ring?"

"Do you want to sell it?" asked the clerk, taking a rapid visual estimate not of the ring but of its owner.

"Well, I might sell it if the offer was enough."

"The boss is out, and I can't buy for the store," remarked the man behind the counter.

"Well, you might take a look at it and give me an idea of what you think I'd be likely to get for it."

Picking up the ring the clerk examined the stone and said: "You can't tell much about a diamond un'er this light. I'd have to see it in the daytime. It might be off color and I couldn't tell it in this light. Bring it in to-morrow or next day."

The owner of the ring, after a few more questions, to which the other returned evasive answers, went out, and the clerk turned to a reporter, who happened to be in the store at the time, and observed:

"That fellow sell that ring? Not in a thousand years. I spotted him the minute he came in. He's a pricer; but he didn't get much out of me."

"What's a pricer, and why wouldn't you tell him what his ring was worth?" we asked.

"One at a time when you come to questions. I wouldn't tell him what the ring was worth because he's got too good a nerve, coming in here and wasting my time valuing stones for him that he won't sell. If it got known that I was a good thing for offering prices on stones the place would be full of pricers trying to work me all the time. What's a pricer? Why, just what you saw there. A chap that doesn't know what his stuff is worth and tries to get some man whose business it is to know about those things to tell him. It's a regular graft down here. There's two kind of pricers around. One kind is the fellows that just want to find out for curiosity what their jewelry is worth. Maybe they got it in some swell jewelry store, where you have to pay extra prices for the name, and they know it and want to find out just how much the thing is really worth. They generally get angry if you tell 'em the fair price, for they think it ought to be more.

"Then there's the kind of chap that wants to hock a ring or a scarf pin, and doesn't know really how much he ought to ask on it. He comes here and asks what we'll buy it for, to get a line on its real value; but it's a cinch that he hasn't any idea of selling it. Sometimes instead of asking how much we'll give for it, the owner will ask what we'll duplicate it for; but that doesn't work either. You can pretty generally tell a man that really wants to sell, and he's the only one that gets a price from this establishment. But you'd be surprised to see how many come here to try on the pricer graft.—*New York Sun*,

The prettiest of the new perfume atomizers are glass covered with perforated silver. The silver bottles are inconvenient in not allowing the state of the liquid to be seen.

## Queries by Circular Readers.

Editor of THE JEWELERS' CIRCULAR:

Which is the best way to clean marble clock cases? Please let me know in next issue, and oblige

AUG. LOCH.

ANSWER:—Cleanse the case thoroughly with a stiff paste prepared from magnesia and benzine; make the paste stiff enough so that when you pinch a quantity between thumb and forefinger a drop of benzine will appear. After having the case as clean as possible, take a lump of hard, white beeswax, rub all over, then burnish with a clean—that is, free from dust and fiber—woolen rag. The writer once was eminently successful with a paste prepared from marble dust, the residue of the polishing shop in a marble-cutting yard, and benzine. With this he polished the case, and succeeded to admiration.

Editor of THE JEWELERS' CIRCULAR:

Would you kindly inform me in your next issue what means must I take to obtain a patent in the United States for a sleeve link; probable cost, etc.?

S. J. RUGG.

ANSWER:—The most rapid and economical method to obtain a patent on an invention is to employ the services of a patent lawyer. The cost is as follows: First government fee, \$15; attorney's fee from \$30 to \$40; second government fee, \$20. C. T. Belt, Warder Building, Washington, D. C., and H. A. West, 59 Liberty St., New York, are recommended as able patent attorneys.

## Famous Old Clock.

THE Grand Lodge of Masons in New York recently came into possession of a very interesting relic in the shape of a grandfather's clock that struck the hours for Yorktown Lodge in the troubled days when George Washington, Lafayette and other officers of the Continental Army used to visit it and attend its sessions. The lodge ceased to exist in 1812 and the old clock was probably sold with the rest of the furniture. It was unearthed in a Baltimore pawnshop by Dr. A. B. Lyman, of Lyman, Md. The doctor had his attention attracted by the figuring on the dial, which showed it to be a masonic clock. He traced back its history, and established beyond doubt that it was made for the Yorktown Lodge in 1781 by John Fisher, whose name and home town are engraved on the dial.

The clock has been placed in the east end of the library at the Masonic Temple. It is an eight-day clock, in a mahogany case, and stands about 8 feet high. On the brass dial are engraved the Masonic square and compass, the columns and the mosaic pavement, with the name, "John Fisher, Yorktown." It shows the day of the month and the phases of the moon correctly. The moon is represented by the face of a young damsel with very ruddy cheeks, that is alternately hiding behind a brass earth and a brass sun, while the stars of the firmament stare in wonder.



### The Other Side of Life.

#### FOILED AGAIN.

The outlaw sneered.

"Aha!" he cried in triumph; "in my power at last."

"Never!" shrieked the captive maiden.

There was the sudden glint of polished metal.

"Perdition! How—"

The robber shrank away in fear.

"—Did she get that lorgnette?"—*Puck.*

#### THE BEGGAR AND THE PUG NOSE.

A gentleman whose nose was of a decidedly retrouse type gave a copper to a poor man with one eye.

"May Heaven preserve your sight!" the beggar exclaimed.

"And why my sight, so particularly?"

"Because, if ever you became shortsighted, you could not possibly wear eyeglasses."—*La Semana Comina.*

#### DE GUSTIBUS NON.

"The fair did much for the art of Chicago."

"Yes; a girl out there sent me a set of fish plates for Christmas that she hand-painted herself."

"They were appropriately decorated, were they?"

"Well, she had painted a gle-worms in the bottoms of them."—*Judge.*

#### AND SHE BELIEVED HIM.

ANGELINA—That was a lovely engagement ring you gave me last night, dear; but what do those initials, E. C., mean on the inside?

EDWIN—Why—er—that is—don't you you know that's the new way of stamping 18 karats?—*Judge.*

Mrs. Yang Yu, wife of the Chinese minister, attended the theatre in Washington and "maintained her composure under a thousand glasses." Colonel J. Hampton Hoge of Virginia could hardly do better than that. — *Rochester Herald.*

"There's grounds for a strike," said the agitator.

"Where?" asked a workman.

"In the clock factory. A young fellow just told me that some of the hands there worked 24 hours a day."

Can anybody give a good reason wh clocks should not strike when they are required to work over time?—*Troy Press.*



TRUTH TRIUMPHANT.

Mrs. GADDERS—What do you think of my new onyx clock?

VISITOR—Beautiful! Is it an alarm clock?

WILLY GADDERS—Yes—

Mrs. GADDERS—Willy, Willy! How dare you tell such an untruth?

WILLY GADDERS—Well, if you had seen how it alarmed pop when he got the bill you would say it was.—*Puck.*

# THE JEWELERS' CIRCULAR

IS FIRST IN THE FIELD IN EVERY SENSE.

SEND US \$2.50 AND GET "THE CIRCULAR" FOR ONE YEAR AND A COPY OF

## "WORKSHOP NOTES

For Jewelers and Watchmakers."

BEING A COLLECTION OF THE LATEST PRACTICAL RECEIPTS ON THE MANUFACTURE AND REPAIRING OF WATCHES AND CLOCKS, AND ON THE VARIOUS PROCESSES ENTERING INTO THE MANUFACTURE AND REPAIRING OF JEWELRY, AS COLORING, POLISHING, ENAMELING, ANNEALING, OXIDIZING, ETC. IN SHORT A THOROUGH COMPENDIUM OF THE NUMEROUS MECHANICAL DEPARTMENTS OF THE JEWELERS' AND WATCHMAKERS' SHOP.

200 PAGES, BOUND IN CLOTH, STIFF COVERS.

THE JEWELERS' CIRCULAR PUBLISHING CO.,  
189 BROADWAY,  
NEW YORK.



# HINRICHS & CO., BRIC-A-BRAC AND ART POTTERY.

29 AND 31 PARK PLACE,  
NEW YORK.

## SEEING



is believing, and to see the product of our Optical prescription department, will lead you to believe that your popularity as an Optician will increase if we fill your orders.

**QUEEN & CO.,**

MANUFACTURING OPTICIANS,

1010 Chestnut Street, Philadelphia.

**REMOVAL!**

**L. BLACK & CO.**  
178 BROADWAY,

WILL REMOVE IN APRIL TO THEIR FACTORY,  
**DETROIT, MICHIGAN.**

**ALBERT BERGER & CO**  
47 MAIDEN LANE, N. Y.  
Spectacles & Optical Goods,  
GROUND LENSES A SPECIALTY.

**WM. BIRMINGHAM & CO.,**  
MANUFACTURERS OF  
All Kinds of Leather Spectacle and Eye Glass  
**CASES,**  
72R Arch Street, PHILADELPHIA, PA.

**G.A. WEBSTER**  
42 & 44 Madison St., Chicago, Ill.  
**Manufacturer,**  
AND WESTERN AGENT FOR  
E. G. WEBSTER & SON, of Brooklyn, N. Y.  
A. F. TOWLE & SON CO., of Greenfield, Mass

**THE PHILADELPHIA COLLEGE OF HOROLOGY**  
A Practical School for Watch-Makers.

Most complete school of horology in America, elaborate outfit of appliances. Skilled and competent instructors. Jewelry work and stone-setting taught, also engraving. Send for prospectus.

**F. W. SCHULER & CO.,**  
No. 623 HEED BUILDING, PHILADELPHIA, PA.

**Headquarters**  
FOR  
**ELECTRIC & PORTABLE**  
**Watchman's Clocks**

Lowest Prices.  
Latest Improvements,  
Patents 1886-1893.  
Send for Circular.  
**E. O. HAUSBURG,**  
41 Maiden Lane, New York.



Price, Complete \$10.00



THE "ALERT."

*We Know*



THAT WE CAN GIVE YOU BETTER RETURNS ON YOUR OLD GOLD AND SILVER OR WASTE THAN ANY ONE ELSE. TO PROVE THIS STATEMENT GIVE US ONE TRIAL.

**GEO. M. BAKER,**

GOLD AND SILVER REFINER  
AND SWEEP SMELTER.

**PROVIDENCE, R. I.**

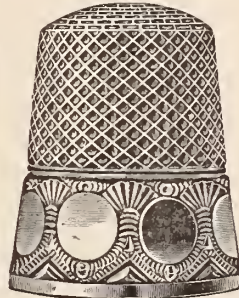

**KETCHAM & McDOUGAL**  
MANUFACTURERS  
GOLD & SILVER THIMBLES,  
GOLD COLLAR BUTTONS,  
AUTOMATIC EYE-GLASS HOLDERS  
198 BROADWAY N Y

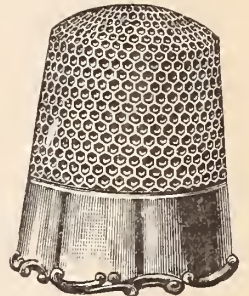

We Have Removed to .....  
**57 MAIDEN LANE.**  
**LEONHARDT & CURRAN,**  
MANUFACTURERS OF DIAMOND MOUNTINGS.

**"Old English"**  
Coffee Spoon.



DESIGN PATENTED.

**Towle Mfg. Co.,**  
MANUFACTURERS OF  
**STERLING SILVERWARE.**

NEWBURYPORT: No. 214 Merrimack St. CHICAGO: Nos. 149 & 151 State St.



**McIntire, Ulmer & Co.,**

WHOLESALE OPTICIANS,  
127 SO. 8TH STREET, PHILA., PA.

**PRESCRIPTION : SPECIALTIES.**

Best Work, Low Prices. Prompt Service.



# Fancy Gems

**M. D. ROTHSCHILD,**

NEW YORK: 41 & 43 MAIDEN LANE

LONDON: 15 HOLBORN VIADUCT

PARIS: 58 RUE LAFFITTE.

**HENRY FERA,**  
IMPORTER OF DIAMONDS  
AND DIAMOND BORTZ,  
Diamond Cutting and Polishing Establishment.  
10 Maiden Lane, NEW YORK.

For **BADGES AND MEDALS,**  
Flag Pins, Class Pins, Class Rings  
and Special Work of all Descriptions.  
SEND TO **E. R. STOCKWELL,** MANUF'R.  
19 John Street, New York

# Opals

**E. E. KIPLING,**

182 Broadway, New York.

ELEVATOR ENTRANCE, 2 JOHN ST.

## S. F. MYERS & CO.,

WHOLESALE JEWELERS,  
MYERS BUILDINGS, - - NEW YORK.

1894 ISSUE, No. 38,

### OUR ROYAL CATALOGUE

Illustrates all that is new, unique and desirable in everything that pertains to jewelry.

Sent free to dealers who have not received it.

TWENTY-TWO DEPARTMENTS.  
SEVEN DOUBLE FLOORS.

Myers Buildings, 48-50 Maiden Lane, New York,  
33-35 Liberty St.,

### NEW CLOCK STAFF WRENCH.



This entirely new and most useful tool is for setting up clocks, particularly fine and costly ones. Can remove pivots at ease. No chance of displacing other pivots in the operation. For description, send 5c. in stamps for catalogue of over one thousand varieties of fine tools.

O. W. BULLOCK & CO., Springfield, Mass.

## Jules Jürgensen

OF COPENHAGEN.

The reputation these watches have maintained for **Fifty Years** has never been equalled, being made on strictly scientific principles and no expense spared to give the **Best** results in mechanism and timekeeping qualities.

SOLE AGENTS,

**John E. Hyde's Sons,**  
NO. 27 MAIDEN LANE

FRENCH ENGLISH  
CLOCKS AND HALL CLOCKS AND  
MATERIALS. MATERIALS

**CHAS. JACQUES CLOCK CO.,** 22 CORTLANDT ST., N. Y.

## L. LELONG & BRO.,

GOLD AND SILVER

Refiners, Assayers AND Sweep Smelters,

◁ SOUTHWEST CORNER HALSEY AND MARSHALL STREETS, ▷

**NEWARK, N. J.**

SWEEPINGS A SPECIALTY.

## J. SCHAWEL & CO., 29 John St., N. Y

GOLD & SILVER REFINERS, ASSAYERS & SWEEP SMELTERS.  
STERLING SILVER, 925/1000 FINE IN SHEET AND WIRE.  
Soft Platinum, Sheet and Wire for Manufacturing Jewelers.

MAY 1ST.  
**REMOVAL** TO Diamond Exchange Bldg.  
14 MAIDEN LANE.

**C. Cottier & Son,** Importers of Precious Stones.  
171 BROADWAY, N. Y.

# ALBERT LORSCH & Co.,

37 MAIDEN LANE, NEW YORK.

Branch, 167 Weybosset Street, Providence, R. I.

—♦— IMPORTERS OF DIAMONDS, —♦—

Rose Diamonds, Rubies, Sapphires, Emeralds, Opals, Moonstones,  
Fancy and Imitation Stones, Novelties.

..... SOLE OWNERS AND IMPORTERS OF

*The Sumatra Gem,*

REG'D, UNEQUALLED IN  
BRILLIANCE AND  
HARDNESS

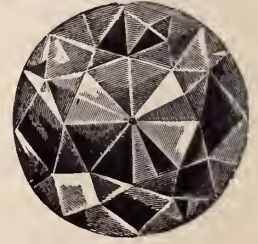
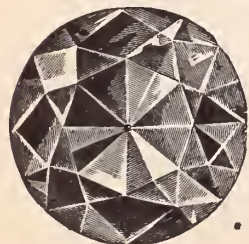

HIGHEST AWARD AT THE COLUMBIAN EXPOSITION, CHICAGO, 1893.

**IT PAYS** TO KEEP IN TOUCH WITH TRADE AFFAIRS.  
THE JEWELERS' CIRCULAR, For 4c. a Week will do it. **Subscribe.**

1869-1894=Twenty-five Years Oldest, Best Brightest, Newest=The Jewelers' Circular.



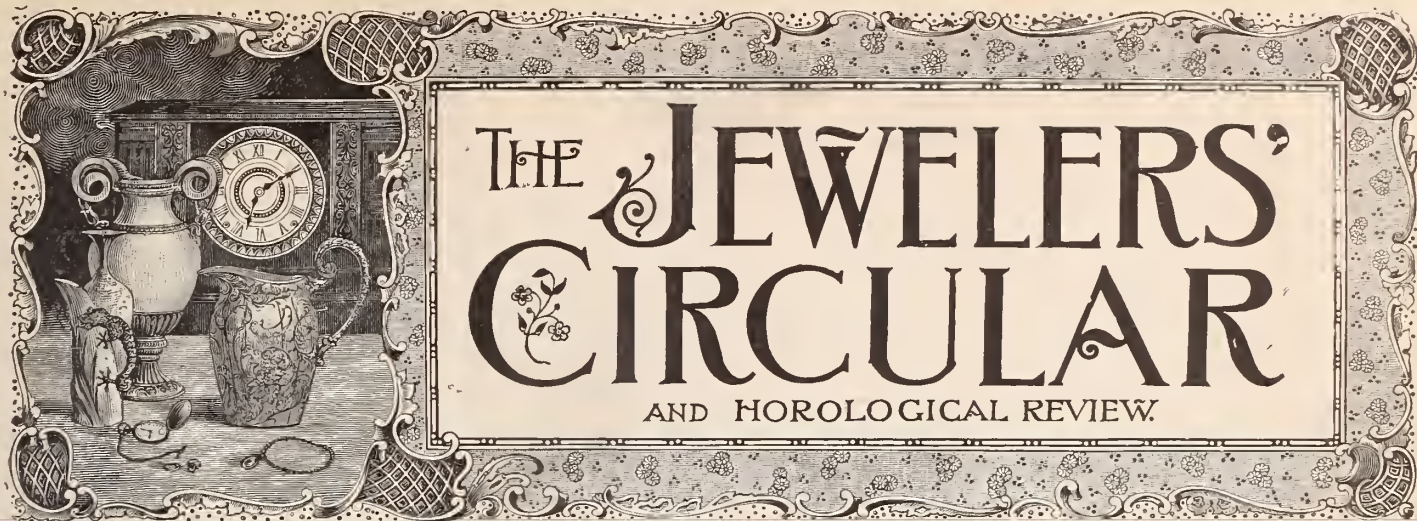

Copyright by THE JEWELERS' CIRCULAR PUB. CO.

189 Broadway, New York.

Entered at the Post Office in N. Y. as second-class matter.

VOL. XXVIII.

NEW YORK, WEDNESDAY, APRIL 25, 1894.

NO. 12.

NAUTICAL INSIGNIA IN SILVERWARE DESIGNING.

THERE have just been shipped abroad by Tiffany & Co., New York, the two silver yacht prizes presented by Ogden Goelet and James Gordon Bennett to the Yachtsmen's Union of Cannes, France, and which have just been raced for there. The house which has become famous for its productions in the way of yacht prizes, has excelled many of its former efforts both in the designing and the execution of these cups. The large piece, which is the \$1,000 schooner prize, is of vase form, stands about 25 inches in height, and is covered entirely with representations of all things nautical. Surrounding the shoulders of the piece is a bold border composed of a number of the heads, necks and arms of tritons in free relief, issuing from the waves and vigorously blowing the shell trumpets of the sea. Below this are several heads with wings attached, suggestive of the wind, and interscattered with the wording, which, in free and artistic lettering, reads as follows:

“Union des Yachtsmen de Cannes Coupe  
Ogden Goelet et J. Gordon Bennett  
fondée en 1893.”

The foot or base of this prize is composed

of shells, seaweed and the trident of Neptune. The vase weighs four hundred and six ounces.

The \$500 prize for sloops is very different in design, being of the punch-bowl form, the bowl part proper resting upon four mermaids, who are issuing gracefully from

three ounces, stands eleven and one half inches high, and measures seventeen inches in diameter.

Ancient Egyptian Gold Work.

AMONG the gold finds made by the French Director of Excavations in Egypt, M. de Morgan, near one of two ancient brick pyramids not far from Cairo, are a crouching lion, cypresses of gold, a necklace of lion heads, and bivalve shells of gold. A breast ornament bearing the cartouche of Amen-en-hat III. shows that king raising his battleaxe to smite an Asiatic enemy, while he tramples a negro under foot. There are bronze and silver mirrors, heightened with gold, jew-



THE \$500 GOELET-BENNETT TROPHY, RACED FOR AT CANNES, FRANCE.

elery with amethysts, carnelians, lapis lazuli and Egyptian emeralds, vases of carnelian, obsidian and alabaster. The carving of some of these jewels, especially in the rings, is said to be marvelous. Examined with a glass, the human figures are seen to have every muscle correctly modeled. Necklaces, bracelets, chased and set with hard stones and pearls,

elery with amethysts, carnelians, lapis lazuli and Egyptian emeralds, vases of carnelian, obsidian and alabaster.

The carving of some of these jewels, especially in the rings, is said to be marvelous. Examined with a glass, the human figures are seen to have every muscle correctly modeled. Necklaces, bracelets, chased and set with hard stones and pearls,



# DEITSCH BROS.,

7 EAST 17TH ST., NEW YORK.

## LEATHER GOODS.

EBONY AND SILVER COMBINATIONS.

ORIGINATORS AND MAKERS OF

NOVELTIES IN LEATHER AND STERLING SILVER COMBINATIONS.



### CROSS & BEGUELIN, 17 MAIDEN LANE, NEW YORK,



960 GOLD PIN. \$15.60 doz.



944 GOLD PIN. \$12.00 doz.



986 Gold Lapel Button. \$8.40 doz.



1117 SCARF PIN. Gold, \$5.60 doz. Silver, 2.80 doz.



341 GOLD CHARM. \$43.30 doz.



421 CHARM. Gold, \$15.60 doz. Silver, 7.80 doz.



1181 PIN. Gold, \$8.40 doz. Silver, 4.20 doz.



1018 PIN. Gold, \$7.60 doz. Silver, 3.80 doz.



1190 Enameled Pin. Gold, \$9.60 doz. Silver, 4.80 doz.



960 GOLD PIN. \$15.60 doz.



803 GOLD PIN. \$10.80 doz.



1081 LAPEL BUTTON. Gold, \$12.00 doz. Silver, 6.00 doz.

HEADQUARTERS FOR Emblems, Gold, Silver and Plate.

Write for Illustrated Catalogue.

### AMERICAN SYNDICATE OF Jewelers' Auctioneers.

ESTABLISHED for the sole purpose of conducting sales for established Jewelers in the United States, Canada and Mexico. We do not sacrifice your goods. We take no sales on a percentage. Our terms are strictly one-half the profits realized on all goods sold. We guarantee you against any loss. We pay all our own expenses; we don't ask you to pay one cent of expense on our account. We buy stocks complete as well as sell them. If your stock is small, or your assortment is not complete, we will furnish from one to ten thousand dollars worth of any kind of stock you may need and in which you need not invest one penny. Don't make any arrangements with others until you read our pamphlet which we will send you free, giving you full particulars of our style of doing business, and the liberal offers we make to Jewelers. We don't care how small your stock is, we will furnish all the stock you need to make a successful sale. We challenge the world for any fairer or more liberal propositions than we make Jewelers. Don't fail to send us your address, and we will send you our business pamphlet, which gives you full explanations as to our terms and style of doing business. Address,

### AMERICAN SYNDICATE OF JEWELERS' AUCTIONEERS.

Offices: 20 WEST 14th STREET, NEW YORK. 611 PENN AVE., WASHINGTON, D. C.

### CAMPBELL-METCALF SILVER CO.

Choice Conceits IN		Sterling Silver ONLY.
--------------------------	--	-----------------------------

2 Maiden Lane, N. Y., with Holmes & Edwards Silver Co. 66 Stewart St., Prov., R. I. Mills Bldg., San Francisco, 8th Floor, Room 1.

## REMOVAL OF American Morocco Case Co. TO 38 E. 19th ST., N. Y.

OUR SPECIALTIES WILL CONTINUE TO BE

- FINE SILVERWARE CASES COVERED WITH SILKS, LEATHER AND OTHER FABRICS
- FINE CASES FOR JEWELRY AND WATCHES.
- FINE HARD WOOD TRUNKS WITH ONE OR MORE DRAWERS.
- SHOW CASE TRAYS IN ALL GRADES.

JACOT & SON IMPORTERS AND MANUFACTURERS OF MUSICAL BOXES 39 Union Sq., New York.



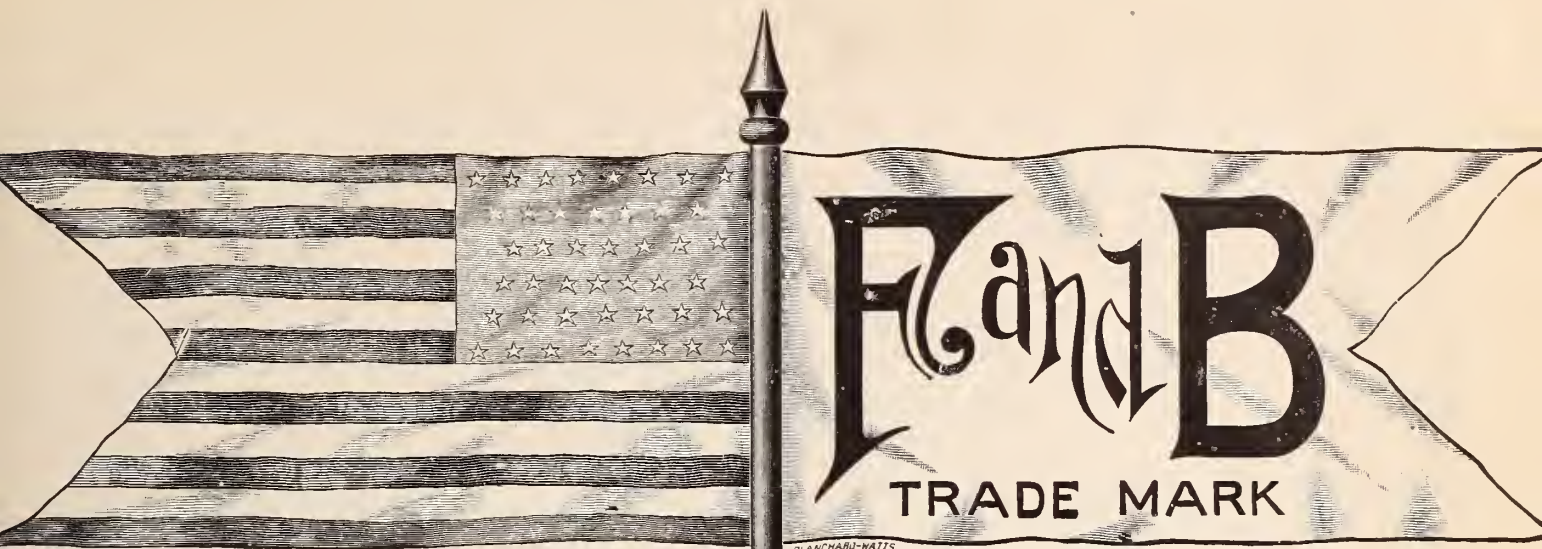

No. 1. Match Box and Cigar Cutter Combined.



No. 2. Match Box and Cigar Cutter Combined.



**Chains**  
 Our new line of chains will assay 10 karat 1-10 gold. All gold soldered.  
**American F. & B.**  
 1-10 gold.

<p><b>Watch Chains for Gentlemen</b>                  These goods are of fine quality, and guaranteed to give satisfaction. Some recently added have sold far beyond expectation. They are made of heavy rolled plate in all sizes and patterns.</p>	<p><b>Watch Chains for Ladies</b>                  Our Victoria and Princess chains are neat and pretty. They are made in all bright, Roman and bright, platinum and bright gold, and have one or two charms.</p>
--	---

<p><b>Charms</b>                  This line is adapted to ladies' or gentlemen's chains, and includes a number of heart charms in Roman, bright and satin finish, with stones and without.</p>	<p><b>Hair Chain Mountings</b>                  In solid gold and rolled plate. We are headquarters and make everything desirable in this line.</p>	<p><b>Bracelets</b>                  We make a large stock of curb bracelets in five sizes, besides the graduated links, with padlocks and snaps, in chased and plain polished, Roman, rolled silver plate and sterling silver. Also padlocks with keys and a push snap.</p>
--	---	--

<p><b>Pins</b>                  Our large line of lace and cuff pins comprise many desirable patterns in gold fronts engraved and trimmed. Also includes baby pins and scarf pins.</p>	<p><b>"Mt. Hope" Buttons</b>                  These are superior to any button in the world. They are easy to put in and easy to take out of the cuff.</p>	<p><b>Link Buttons</b>                  This line has increased rapidly with us, and is very low in price, embracing all styles in Roman, chased, engraved and plain, with and without stones, and some in enamel.</p>	<p><b>Crosses</b>                  We make four sizes of gold filled in plain, engraved and set with stones, and suitable for our neck chains.</p>
--	--	--	--

<p><b>Sterling Silver and Solid Gold Sword Scarf Pins</b></p>	<p><b>Glove Buttoners</b>                  We make the interlocking and one with a twist handle in gold rolled plate and silver rolled plate.</p>	<p><b>Earrings</b>                  This line includes many pretty patterns in gold fronts engraved, some with pretty trimmings and a small line of loop drops.</p>	<p><b>Neck Chains</b>                  We make a variety of neck-chains in bright and Roman, with snaps.</p>	<p><b>Sterling Silver Bracelets and Padlocks</b></p>
---	---	---	--	--

	<p><b>Gold Locket Set with Diamonds</b>                  These lockets are made of 10 karat gold throughout and set with brilliant diamonds. They cannot be surpassed in finish or cheapness of price.</p>	<p><b>Gold Locket Engraved</b>                  These lockets are also made of 10 karat gold throughout, with beautiful designs engraved thereon and the price is so low that they cannot fail to be in great demand.</p>	<p><b>Gold Front Locket</b>                  This line is very extensive. Many patterns are plain polished, others intricately engraved, with and without stones.</p>	<p><b>Rolled-Plate Locket</b>                  This line is almost endless, and consists of nearly every conceivable shape, size and style. Some are set with imitation diamonds, rubies and sapphires.</p>	
---	--	---	---	---	---

We have put upon the market a line of Gentlemen's Chains and Ladies' Chain Bracelets made of 1-10 gold stock. Every joint is soldered with gold, and every Chain or Bracelet will assay more than 1-10 gold. They are our AMERICAN F. & B. 1-10 GOLD goods, and are so stamped. Bar, Chain and Swivel are stamped 1-10 gold.

**FOSTER & BAILEY,** 100 RICHMOND ST., PROVIDENCE, R. I.





**\$4.50**  
Per Dozen.

Sterling Silver "TROLLEY" or Hat Guard for Straw Hats, unlimited Sale THIS YEAR. Gold and Silver Art Match Boxes, Diamond and Half Pearl Brooches, Swords and Scarf Pins. Repairing a Specialty.

CLARENCE W. SEDGWICK,  
11 EAST 20th ST., - NEW YORK.

are said to be marvels of beauty, surpassing all the work of later reigns, which are mere debased copies of these ancient ornaments. In texts the find is not rich; but few pyramids have yielded much in that line.

**Provisions of the Will of Hon. Samuel Simpson.**

WALLINGFORD, Conn., April 18.—The will of the late Samuel Simpson was filed in the probate court, to-day. The document is a lengthy one and was drawn and signed Feb. 20th, of the present year. Six executors are named as follows: Mrs. Samuel Simpson, Mr. and Mrs. G. W. Hull, Mr. and Miss C. H. Tibbetts and Bessie C. Hull. There are several public bequests, the largest one amounting to \$50,000, for the Ladies' Library Association. A lot on Main St., 50 feet front, in the center of the town, is given with \$25,000 for the erection of a building thereon as a memorial to a daughter of the deceased, Martha DeEtte Simpson, and \$20,000 as a permanent fund, the income of which is to be used in the purchase of books, and for keeping the building in repair and insured.

The homestead on Main St. with some 272x300 feet is given to the widow during her life time. To her is also given the use of an income of \$100,000 of the estate, the household furniture, horses, carriages and barn utensils.

To St. Paul's Church is given as a memorial to his deceased daughter, M. De Ette Simpson, \$2,000 as a permanent fund, the income of which shall only be used annually and for specified purposes. To St. Paul's church \$3,000 is also given on condition that the church shall liquidate its debt, which is \$4,000.

The granddaughters, Mrs. C. H. Tibbetts and Miss Bessie C. Hull, are each given \$25,000 absolutely. The homestead also goes to Miss Bessie Hull at the decease of her grandmother and mother. Mrs. Gurdon W. Hull, his daughter, is given the use of the homestead and the property corner of Main and Center Sts. during her lifetime. She is also given \$50,000 absolutely. To relatives bequests of various amounts are made. The estate is estimated to be worth \$1,000,000.

**JOHN R. KEIM, MANUFACTURER OF FINE DIAMOND JEWELRY,**  
\* \* \*  
**21 East 17th Street, New York.**

SOLE AUTHORIZED MANUFACTURER OF THE PALMER COX "BROWNIE" JEWELRY, AND ALL ARTICLES IN ENAMEL OR METAL; BY PURCHASE FOR THE PURPOSE FROM PALMER COX, ESQ., OF HIS COPYRIGHTS, PATENTS, PATENT RIGHTS AND ORIGINAL "BROWNIE" DESIGNS.

WE manufacture Souvenir and Advertising Spoons in Sterling,

Aluminum and

Electro-Plate.

Also

Electro-Plated

Spoons, Forks, Knives, Etc.



**NIAGARA SILVER CO.,**

**NIAGARA FALLS, N. Y.**



THE  
*Pairpoint*  
 Makers and Designers of  
 "Superior" Gold  
 AND  
 Silver Plate



NO 934. RING STAND, PIN CUSHION AND TRINKET TRAY COMBINED.

MEG. COMPANY,

FACTORIES:  
 New Bedford,  
 Mass.

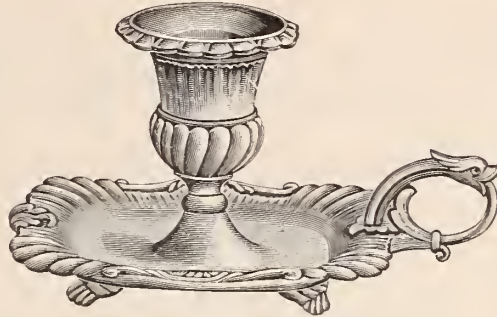

NO. 6105 CANDLESTICK.

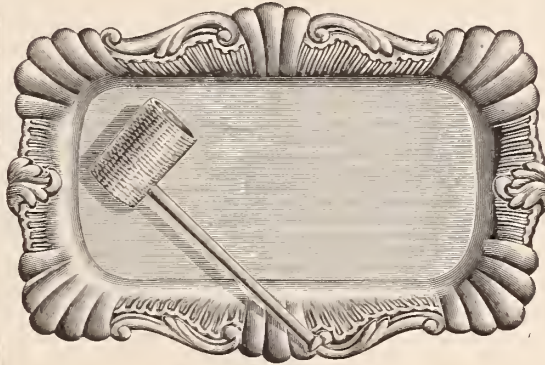

NO. 1962. ASH RECEIVER.

Rich Cut Glass

AND FINE

Decorated Art Wares.

THE BEST selling goods  
 on the market bear the  
 stamp of.....

PAIRPOINT.



NO. 3744. TOOTH PICK HOLDER.

A. J. LOGAN,  
 MANUFACTURER OF  
 WATCH TOOLS, HAIR SPRINGS AND  
 WATCH MATERIALS.  
 ◀ New Catalogue just issued, Sent on Application. ▶  
 WALTHAM, MASS.

CROUCH & FITZGERALD.



Jewelry Trunks  
 and Cases,  
 161  
 Broadway,  
 Bet. Cortlandt and  
 Liberty Sts.,  
 688 B'way,  
 701 6th Ave.,  
 NEW YORK.

PATENTS SECURED WITHOUT  
 FAIL OR DELAY.

Send Rough Sketch or Model and I will tell you  
 whether you can obtain a patent,  
 WITHOUT CHARGE.

Fifteen years' experience. Ample references. Address

C. T. BELT,  
 WARDER BUILDING WASHINGTON D. C.

2 MEDALS AWARDED



AT  
 WORLD'S  
 FAIR,  
 1893.

Providence Shell Works, Providence, R. I.  
 Correspondence Invited.

We sell to the legitimate Jewelry and Stationery  
 trade only.



NEW YORK

CITY, U.S.A

CHOICE PAPERS

MAKERS OF

FINE STATIONERY

For Correspondence, Wedding and Business Use, handsomely  
 boxed, specially suited to the Jewelry Trade.

18 MURRAY STREET, NEW YORK.



# R. WALLACE & SONS MFG. CO.

SILVERSMITHS

Trade Mark.

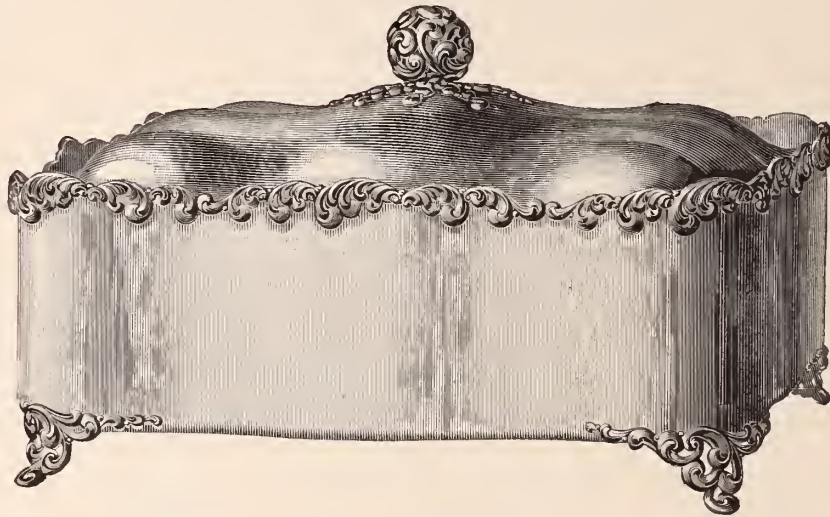

WAVERLEY SARDINE BOX.

Manufactories and  
Main Office,

WALLINGFORD, - - CONN.

BRANCHES :

NEW YORK  
3 PARK PLACE.

SAN FRANCISCO,  
120 SUTTER STREET.

CHICAGO  
86 WABASH AVENUE.



**U. S. Supreme Court Decision Anent Pearl Shell Opera Glasses.**

WASHINGTON, D. C., April 20.—A case arising under the tariff act of 1883, has just been decided in the United States Supreme Court. This case involving the classification for duties of pearl opera glasses, was an action by the firm of Schlesinger & Mayer against the Collector of Customs at the port of Chicago, to recover the duties paid upon importation of pearl opera glasses entered for consumption at the Custom House at Chicago. The case was tried without a jury, in the Circuit Court of the United States, for the Northern District of Illinois. This court made a special finding of facts, and awarded to plaintiffs judgment for \$6.60 upon the opera glasses. The defendant sued out a writ of error from this court, appealing to the Supreme Court of the United States.

The opinion of the Supreme Court was rendered by Justice Brown, and is as follows:

With references to opera glasses, the court found that the plaintiffs had imported certain shell covered opera glasses, composed of shell, metal and glass, upon which said merchandise the plaintiffs paid a duty of 45 per cent ad valorem, assessed by the defendant collector as "manufactured articles, composed in part of metal," under Schedule C, act of March 3, 1883, that plaintiffs protested and appealed to the Secretary of the Treasury, claiming that these opera glasses should be assessed a duty of 25 per cent ad valorem, under Schedule N, "sundries," as "shells, whole or parts of, manufactured, of every description," and under section 2499, as "articles composed of shell, metal and glass in which the shell is the component of chief value."

The court further found from the proofs that the "said opera glasses are composed of silver or nickel-plated metal tubes, fitted to slide within each other, and held together by a metal framework or connections, said tubes containing glass lenses properly fitted therein, and that said tubes are inclosed in a cover of polished mother-of-pearl; that the shell, when manufactured, or brought to the proper shape for such cover and properly polished, costs more than the glass lenses and metal tubes and frame when finished and ready to be combined with said pearl to make a complete opera glass."

In this connection our attention is called to the fact that while an exception was taken to the ruling of the court with respect to goat skins, none was taken to its rulings with respect to the opera glasses. This, however, is immaterial, no exception being necessary, in case of special findings by the court, to raise the question whether the facts found support the judgment. The court below was of opinion that taking the designation of "shells, whole, or parts of, manufactured," found in Schedule N, page 514, in connection with the last clause of R. S., Section 2499, that "on all articles manufactured from two or more materials the duty shall be assessed at the highest rates at which the component material of chief value be chargeable, these opera glasses should have been classified as manufactured shells, inasmuch as it appeared that the shell, when manufactured or brought to the proper shape for such covering and properly polished, costs more than the glass lenses and metal tubes and framework, when finished ready to be combined with said material to make a complete opera glass." We held this method of computation to be correct in *Seelberger v. Hardy*, (150 U. S. 420), but the question of the proper classification of the opera glasses was not considered in that case.

We think the court was in error in holding that the articles in question were shells whole, or parts of, manufactured, as this clause was obviously intended to apply to articles made entirely, or nearly so, of shell, such as combs, bracelets, chains, and lognons, and not to articles of which shell was a mere component, though, perhaps, as in this case, the most valuable part. Nor

# ANNOUNCEMENT.



Beginning with May 1st, '94, our New York Office will be discontinued and all communications received and business transacted in our Factory office.

**BIPPART & CO.,**

Cor. Marshall & Halsey Sts.

Newark, N. J.

## THE BOWDEN SEAMLESS RING

IS MADE ONLY BY

**J. B. BOWDEN & Co.,**

Makers of Finger Rings of every Description.

REMOVED FROM BROADWAY AND JOHN STREET,

**TO 3 MAIDEN LANE, NEW YORK.**

## MATHEY BROS., MATHEZ & CO.,

21 & 23 MAIDEN LANE, N. Y.

BRASSUS, SWITZERLAND.

Manufacturers and Importers of

Plain and Complicated WATCHES.

**SPLITS**

A SPECIALTY.

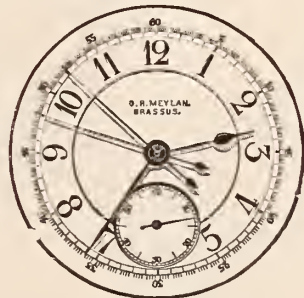

Sole Agents for

## Jaques Lecoultre Razors.

Prices of LATHES and CHUCKS are "WAY DOWN"

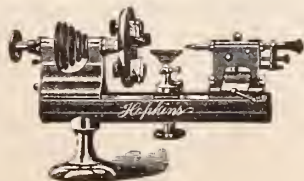

All purchasers of our THREE FOUR lathes and chuck combinations now receive FREE our new TIP OVER "T REST", on which we have patent pending. The most valuable addition to plain lathe in recent years.



SEND FOR FEB. PRICE LIST.

WALTHAM WATCH TOOL CO., SPRINGFIELD MASS



# Great Reduction in Watch Glasses.

To make room for a large Stock of W. B. & C. Watch Glasses, which is the only kind we are going to keep, we will sell out our Stock of Blue Label Glasses at following prices:



GENEVAS, - = - =	at \$1.40 per gr.
MI CONCAVES, - = - =	1.80 " 6% for Cash.
PAT. GENEVAS, - = - =	3.40 "

**NOW IS THE TIME TO STOCK UP.**

We carry a full stock of Tools and Materials at the lowest prices. And also give strict and prompt attention to repair work of all kinds for the trade, thus enabling our customers to save time, trouble and Money by concentrating their orders.

## FISHER & SONS, 63 NASSAU ST., New York.

### Sterling Silver Match Boxes

WITH CIGAR CLIPPER ATTACHMENT.

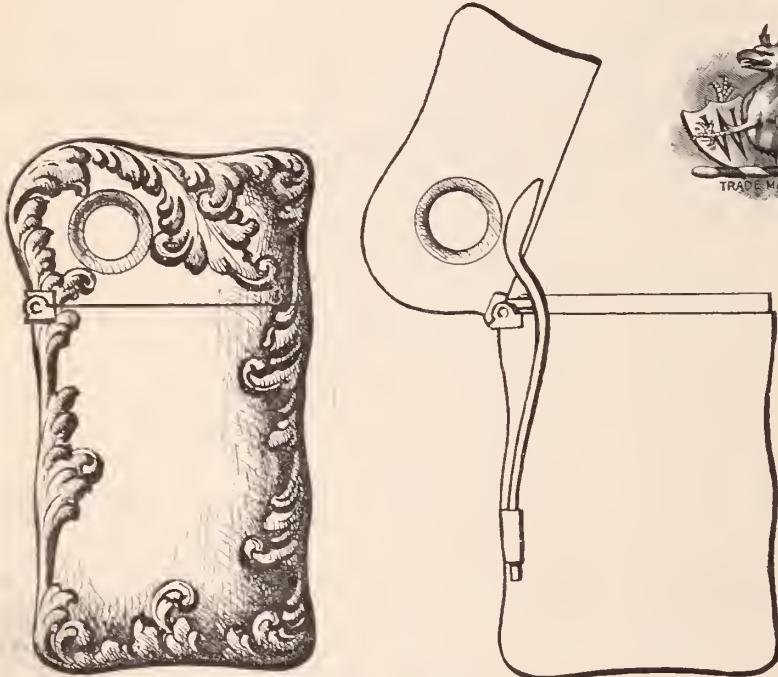

PLAIN OR FANCY.

## F. M. Whiting & Co., = NORTH ATTLEBORO, MASS.

Sterling Silver Hollow ware, Flatware, Novelties, Toilet Articles, &c.  
 NEW YORK OFFICE 857 Broadway. AFTER MAY 1, 1128 B'way & 208 Fifth Ave.  
 HANDSOME NEW CATALOGUE SHOWING 22 PATTERNS IN TEAS, AND 36 PATTERNS IN COFFEE SPOONS WILL BE MAILED ON APPLICATION.

## McIntire, Ulmer & Co.,

WHOLESALE OPTICIANS  
 127 SO. 8TH STREET, PHILA., PA.

### PRESCRIPTION : SPECIALTIES.

Best Work. Low Prices. Prompt Service.



are we satisfied that they should be classed as "articles manufactured from two or more materials," in which case, by Revised Statutes, Section 2499, as amended by the act of 1883 (22 Stat. 491), duty should be assessed at the highest rate at which the component material of chief value may be chargeable. In view of the more specific designation in Schedule C, page 501, of "manufactures, articles, or wares not specially enumerated or provided for in this act, composed wholly or in part of metal," and in view of the fact that, while the metal is not the component of chief value, it is a substantial part of the finished glass, and the framework upon which the lenses and shell are mounted, we think these articles should be classed as manufactures of metal. We do not wish to be understood as holding that, if the metal be a mere incident or an immaterial part of the completed article, as, for instance, the screws or knobs upon an article of clothing, such articles should be classified as manufactures in part of metal; but where, as in this case, they form a necessary and substantial part of the article, we think this clause should determine their classification. Particularly is this so in view of the fact that opera glasses are frequently made of glass and metal alone, or with an outer covering of leather, which would form an inconsiderable part of the total expense. It would be obviously unjust that these cheaper glasses should pay a duty of 45 per cent., while the more expensive glasses with shell coverings, are dutiable only as manufactures of shell at 25 per cent.

The views of the courts of the different circuits have not been uniform with respect to the classification of these glasses, but we agree with the district judge in the case of Aloe v. Churchill, (44 Fed. Rep., 50,) that they should be classed as manufactures composed in part of metal under Schedule C, and therefore dutiable at 45 per cent. The judgment of the court below is therefore reversed, and the case remanded for further proceedings in conformity with this opinion.

### Decision Against Jeweler Schall, of Hartford, Establishes a Precedent.

HARTFORD, Conn., April 18.—Judgment has been rendered in the case of Sherman & Crowley of the Brower house vs. Ernst Schall, the jeweler, by Judge Calhoun, in favor of the plaintiffs, ordering that they shall recover \$108.

A confidence man named Kelly struck town one day some months ago and secured by fraudulent means a good check for \$100 from Mr. Schall. He passed the check in payment for his hotel bill at the Brower house and received the balance in money. Mr. Schall discovered that he had been cheated and stopped payment on the check.

Yesterday's decision holds that Sherman & Crowley received the check in good faith and that Mr. Schall must pay it. The case was tried before Justice Case who found for the plaintiffs and the decision has been confirmed in the Common Pleas Court.

### William H. Eaton Makes An Assignment.

PAWTUCKET, R. I., April 19.—William H. Eaton, dealer in watches, clocks and jewelry, 20 Broad St., has made an assignment for the benefit of his creditors, to Edw. W. Blodgett. He was formerly located in the Sheldon building, where he removed from Central Falls, and has occupied his present store ever since the construction of the building in 1892.

Mr. Eaton states that the demand of his creditors, when met, will leave him without a dollar. The news of the assignment was received with regret among his friends and fellow merchants.



**A Further Hearing in the Sterling Silver Legislation Discussion.**

PROVIDENCE, R. I., April 18.—Upon the rising of the House of Representatives yesterday noon, the hearing on the "Sterling Silver" bill was continued before the judiciary committee. The room was crowded by manufacturing jewelers, their representatives or attorneys.

Attorney General Robert Burbank, counsel for the Gorham Mfg. Co., appeared first before the committee. He continued the assertions made by secretary J. F. P. Lawton at the previous hearing that the word "sterling" signified an actual percentage of 925-1000 silver. He gave the derivation of the word from the German. By common usage also "sterling" had come to mean a certain standard and the public had a right to demand the correct marking of the silver which it bought. He said that if the statement made that the Providence manufacturers could not thrive by marking the goods exactly as they were, those firms ought to fail. The silver combs might not be any better looking than those made of white metal, but the woman who bought them had a right to insist that she was getting full value for the money which she paid. On moral grounds and on good business economic grounds the bill ought to pass. It had already passed and was being engrossed in Massachusetts. It had passed the New York Senate and was now in the Assembly with no opposition. If the manufacturers marked their goods "sterling" when they were not sterling silver, for expediency, it was morally not an expediency in the long run. He then quoted the following excerpt from the London *Jeweler and Metal Worker's* account of voluntary vs. compulsory hall-marking:

"It cannot be denied that the subject of hall-marking has, of late years, acquired fresh interest, by reason of the fall in the price of silver and the uncertainty respecting its future exchange value, a matter of grave anxiety to those who have business relations with the east. In view of the fall in the price of silver, and its probable further fall, it is in the highest degree impolitic any longer to maintain laws which may limit its absorption for manufacturing purposes. Surely, it must be impolitic to maintain any laws which limit skilled labor.

"It would really seem from the statements given below that the abolition of the principle of compulsory hall marking would tend to steady the price of silver; would lead to more employment of skilled labor, and would affect public and craft interests only to their mutual advantage.

"In nearly all European countries the respective governments thereof have established officers to test and stamp the quality of goods submitted. The standards adopted in different countries vary from .583 to .950, in many instances a country having more than one standard. This official test and stamping is in some countries compulsory, in others voluntary and in few both: i. e., on some goods the marking is compulsory, while upon others it is wholly optional with the manufacturer. England is an example of the latter. Each silver or gold article weighing over ten penny-weights must be marked. This includes plain gold rings and watch cases, while jewelry in general is not obliged to be marked. Holland also has both a compulsory and voluntary law. In France, Austria, Hungary, Russia, Sweden, Norway and Switzerland a compulsory law exists, and in Germany, Belgium, Denmark, Spain and Italy the marking is entirely voluntary. In Germany manufacturers may mark goods themselves, and are held responsible for the correctness thereof. In Switzerland it is practically the same.

"The standards are: Great Britain—In silver, .925 and .959; in gold, 9, 12, 15, 18, and 22 karats. France—In silver, .800 and .950; in gold, 18 karats or .840 and .920; in gold for export no standard is required. Austria—750, .800, 900, .950; goods for export are not required to be marked, and imports must be marked. Russia—In silver, .840, .880, and 910. Sweden and Norway—.820. Spain—.916. Portugal—.800 and .833. Holland—In silver, .833 and .933. Hungary—.750. Belgium—.800 and .900. Denmark—.826. Switzerland—In silver, .800 and .875; in gold, 14 and 18 karats

"In England, if a parcel of plate sent to be marked falls below the quality .925, the whole lot is smashed. On the other hand, foreign-made goods falling short of the mark will be returned to the owner or agent for re-exportation.

"The position of watch-case makers is most serious. The Waltham Watch Co import many thousand movements to England, and those destined for the British market are supplied with cases at Birmingham to the number of about 36,000 annually. The London office of this watch company receives enormous orders from foreign countries for their watches, which have to be cased outside of England to avoid the hall-marking imposed, which would deprive the watch of its American character. This is a matter of between 50,000 to 100,000 cases annually, a clear loss to Birmingham manufacturers. Another instance is afforded in the experience of a Birmingham manufacturer who received an order from Frankfort for several gross of child's rattles to be made .800 fine. The assay office interrupted the filling of the order. The Birmingham manufacturers are shut out of the Leipsic and Nijni-Novgorod fairs, where cheap novelties are sold in great numbers, by reason of this compulsory hall-marking.

"Are we not told on all hands by all advisers to seek out new markets? How can the British silversmith seek out new markets when the law tells him that he is not to make what new markets require? First alter the law, and then let British enterprise take care of itself.

"The writer is not unmindful of the arguments against these proposals. First, if hall-marking were even voluntary the public would be exposed to fraud. He cannot see how this could occur. Hall-marking, under a voluntary system, would be as general as it now is under a compulsory system. The public demand the mark. Secondly, it would be inconvenient, because manufacturers would have to keep stock of different qualities for foreign buyers. The answer is

simple: They would have to do nothing of the kind. Lastly, why should the law regarding gold differ from that relating to silver? The goldsmith may make whatever he likes, of any quality he may desire, for any market under the sun. If a hall-mark be required, a hall mark he can have. If no hall-mark be required, goods may be of any quality—from 22 karats to no karat at all. And yet gold is, as to silver, of standard i. e., 22 karat fineness.

"Further legislation should follow. All the acts of Parliament now affecting the industry should be boiled down into one single act, based, of course, upon the voluntary system. The datemark should be abolished. The locality mark, of course, then useless. A trade-mark should be accepted in place of the maker's initial mark.

"Most undoubtedly the 'touch-needle' or 'touchstone' should be adopted by assay offices. The 'scrape and parting assay,' in the case of finished goods, is a barbarous practice and it is wholly unnecessary. He had experience in France and Austria in marking by the 'touch.' It is accomplished in a few minutes with the greatest accuracy, and without the slightest injury to the article operated upon."

Vice-president Robinson, of the Gorham Mfg. Co., appeared in behalf of the bill stating that 95 per cent. of the manufacturing silversmiths of the country had come to recognize the word "sterling" as meaning 925-1000 silver. The trade had recognized the mark and the public should have the benefit of it.

Theodore W. Foster, of Foster & Bailey, thought that the bill was a proper thing for Rhode Island. If the trade throughout the country came to know that all the goods from this State marked "sterling" contained 925-1000 silver, then every silver manufacturer in the State would stand a good competitor to the Gorham Mfg. Co. He was of the opinion that not a single manufacturer would be driven out.

Hiram C. Howard, of the Howard Sterling Co., said that it needed no preparation to speak on the question of morals, of right

**THOMAS W. LIND, MANUFACTURER OF JEWELERS' FINDINGS,**  
67 FRIENDSHIP ST., PROVIDENCE, R. I.

**BATTLE AXES**

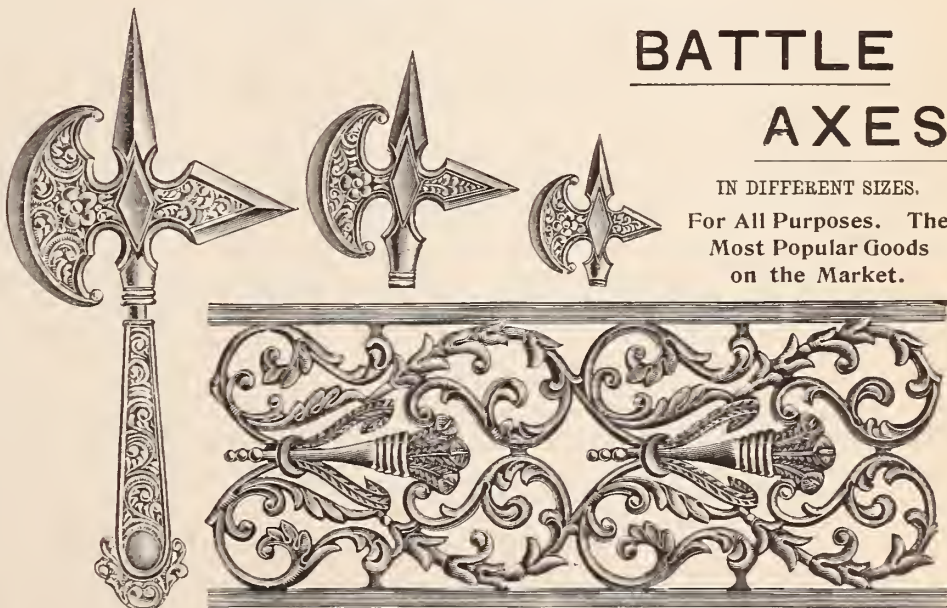

IN DIFFERENT SIZES.  
For All Purposes. The Most Popular Goods on the Market.

THE LATEST ROCOCO—FULL SIZE.

Samples on Application—Write Us.



and wrong. "Sterling" meant 925-1000 to the trade. If it positively does mean something else, why do the opponents to the passage of the bill unblushingly state that their customers demand that their goods shall be marked thus? It is just, he said, that such laws should be enacted to have the mark mean just what it purports to mean.

Representative Henry G. Thresher, of Waite, Thresher Co., appeared as representative for the smaller silver manufacturers against whom it was claimed at the previous hearing that the passage of the bill would mitigate. His remarks were mainly a repetition of those at the last hearing as published in full in the last issue of THE CIRCULAR. He objected to the bill applied to Rhode Island alone. If it should become a general National law, the silver manufacturers in this city would be in favor of it. The small manufacturer was in favor of the passage of a National bill and would use all of their influence for its passage, but would oppose the passage of a local or State bill.

Several other manufacturers objected to the passage of the bill, criticising it as an unjust discrimination against Rhode Island. The hearing then closed. The judiciary committee will report upon this bill in a few days when it will come before the House for passage. The final action of the committee and House is awaited with considerable interest.

#### Harris Fellman Makes an Assignment.

WOONSOCKET, R. I., April 20.—Harris Fellman, dealer in watches, clocks and jewelry, 214 Main St., has made an assignment to Michael Jacobson. His liabilities and assets are unknown, although it is estimated that the former will amount to about \$5,000. A majority of the creditors are Boston and New York jobbing houses.

Mr. Fellman was formerly in business for several years in New York city, where he failed in 1885. About 1888 he removed to this city and began business in his wife's name as E. Fellman. Having presumably settled his old difficulties he resumed his own name in the business about a year ago.

#### Serious Charges of Fraud Brought Against a New York Jeweler.

Adolph Duckler, formerly a jeweler at 39 Willett St., has been locked up in Ludlow St. Jail, New York, in a suit against him in the Supreme Court brought by Norden & Co., diamond cutters, 48 and 50 Maiden Lane, to recover a debt of \$1,600 claimed to have been incurred by fraud and deceit.

Norden & Co. claim that in September, 1892, they sold diamonds worth \$1,600 to Duckler on the representation that he was the owner of 39 Willett St., and was solvent. They claim that when the first of the notes taken in payment for the goods became due, it went to protest, and that an investigation revealed that Duckler was not alone insolvent, but had, during the

latter part of the July previous executed a bill of sale of his business to his wife and had also assigned his property to his wife. They also claim that he drew out money which he had in the Union Square Bank and had redeposited the money in his name as attorney.

#### Forthcoming Meeting of New York State Jewelers.

The following notice has been sent out by C. J. Giering, secretary of the Retail Jewelers' Association of New York State.

MIDDLETOWN, N. Y., April 18, 1894.

DEAR SIR:

You are urged to spare a few hours from your business to meet your fellow craftsmen, on the afternoon of May 2d, next, at 2 P. M., Division Hall, 42 Grand St., Newburgh, N. Y., for the purpose of listening to addresses on the abuses of our trade, and also for the purpose of furthering the organization of the above Association, just instituted at Middletown, N. Y., on the 29th of March, 1894.

We leave it to your own experience of the conditions that crowd the retail jeweler from receiving the return his time and money should bring him, to realize the stern necessity of organization, a move that has become general over the country. To that end we earnestly request your presence at this meeting, and enclose a postal card to enable you to signify the same quickly.

Mr. Arthur S. Goodman, of Philadelphia, president of the National Retail Jewelers' Association, will speak on the "Abuses of the Trade; the Remedy," etc.

Remember, if you are not there, possibly your competitor may be, and what is to his advantage, is also yours. Do not begrudge the few hours required, nor the little expense, but come, and help the good work, as it should be helped.

Fraternally yours,

W. H. LYON, president, Newburgh, N. Y.

C. E. WILLSON, vice-pres., Deckertown, N. J.

C. J. GIERING, secretary, Middletown, N. Y.

B. F. GORDON, treasurer, Middletown, N. Y.

If you are in sympathy with us and cannot possibly come, fill out this application blank and mail to secretary, with fee enclosed.

#### Bids for Silver Plated Ware for the Navy Department.

WASHINGTON, D. C., April 21.—The Navy Department is inviting proposals for furnishing supplies for the New York Navy Yard. These bids are to be opened May 1st. Among the articles required are the following items of silverware, for the *Olympia*. Plated ware for Flag Officer:

2 waiter's trays, 12 inches; 2 sugar bowls, 2 milk pitchers, 1 caster, 1 butter dish, 1 baking dish; 2 vegetable dishes, 8 inches; 1 ice pitcher, 1 fish knife and fork, 1 crumb scraper, 6 nut cracker, 1 teapot.

1 gravy ladle; 1 meat dish, 18 inches; 1 bread tray, 12 inches; 1 gravy boat, 1 black coffee pot, 1 cheese scoop, 4 salt spoons, 1 mustard spoon, 2 sugar tongs, 1 butter knife, 2 pepper mills.

2 baking dish linings, 28 tablespoons, 21 dessert spoons, 21 coffee spoons, 28 tea spoons, 28 table forks, 28 dessert forks, 28 table knives, plated; 28 dessert knives, plated; 1 carving knife, large; 1 carving knife, small; 1 carving fork, large.

1 carving fork, small; 1 steel, 1 soup tureen, 1 pickle fork, 1 soup ladle; 1 sugar bowl, covered; 1 mustard pot, 1 pepper shaker, 1 tea strainer; 1 baking dish, small; 1 chafing dish; 2 baking dish linings, small.

Plated ware for Captain:

1 sugar bowl, 1 milk pitcher, 1 caster, 1 butter dish, 1 baking dish; 2 vegetable dishes, 8 inches; 1 ice pitcher, 1 fish knife and fork, 1 crumb scraper, 6 nut cracker, 1 tea pot, 1 gravy ladle; 1 meat dish, 16 inches; 1 bread tray, 12 inches; 1 gravy boat, 1 black coffee pot.

1 cheese scoop, 2 salt spoons, 1 mustard spoon, 1

sugar tongs, 1 butter knife, 1 pepper mill, 2 baking dish linings, 20 table spoons, 15 dessert spoons, 15 coffee spoons, 20 table forks.

20 dessert forks; 20 table knives, plated; 20 dessert knives, plated; 1 carving knife, large; 1 carving knife, small; 1 carving fork, large; 1 carving fork, small; 1 steel; 1 pickle fork.

1 soup tureen; 1 soup ladle; 1 sugar bowl, covered; 1 mustard pot; 1 pepper shaker; 1 tea strainer; 1 baking dish, small; 1 chafing dish; 2 baking dish linings, small.

Plated ware for wardroom:

2 waiter's trays; 2 sugar bowls, large; 2 milk pitchers; 2 castors; 2 butter dishes; 1 baking dish, large; 2 vegetable dishes, 12 inches; 2 ice pitchers; 2 fish knives and forks; 2 crumb scrapers.

6 nut cracker; 1 teapot; 1 gravy ladle; 2 meat dishes, 16 inches; 2 bread trays; 1 gravy boat; 1 black coffee pot; 1 cheese scoop; 6 salt spoons; 2 mustard spoons; 2 sugar tongs; 2 butter knives; 2 pepper mills; 2 baking dish linings, large; 32 table spoons.

24 coffee spoons; 24 dessert spoons; 32 tea spoons; 32 table forks; 32 dessert forks; 32 table knives; 32 dessert knives.

All of the above articles are to be delivered by July 1st, properly packed for shipment.

#### The Web of Evidence Gradually Surrounding Samuel Goodman.

SPRINGFIELD, Mass., April 21.—Samuel Goodman and Geo. Barker, the men suspected of purloining H. C. Barnum's trunk, were brought here from Rochester this week, and arraigned on a charge of larceny to which each pleaded not guilty. They were held under bonds of \$5,000 each for trial next Tuesday, and not having the necessary sureties were sent to jail in default.

At the coming trial of the two thieves it is expected that a number of witnesses will be called from the west who will testify that the two men sold them a part of the stolen plunder. The police ran across some more of the rings at the home of Goodman's sister, in Brooklyn, N. Y., and the chain of evidence seems to be complete. If Tuesday's trial is against the men they will be bound over to the grand jury, which comes in next month, and will have their trial in Superior Court shortly after.

#### The Death of Elbert B. Monroe.

Elbert B. Monroe, a member of the United States Board of Indian Commissioners, dropped dead at 6.30 P. M. Saturday, at his country home near Tarrytown, N. Y., from a stroke of apoplexy. He had been driving, and had just reached home.

Mr. Monroe was a member of the old firm of Ball, Black & Co., New York, beginning as a clerk in about the year 1855, and becoming a partner about five years later. His father, Ebenezer Monroe, was a member of the firm of Ball, Tompkins & Black, and the widow of the deceased was a Miss Tompkins. Mr. Monroe was about 54 years of age and was largely interested in Y. M. C. A. work, holding high positions in that organization. For many years he lived at Southport, Conn.

Deceased purchased the former home of Gen. John C. Fremont, near Tarrytown, adjoining the country place of Wm. Rockefeller, and had recently made that his residence. President Cleveland appointed



Mr. Monroe one of the nine members of the Board of Indian Commissioners, and he took great interest in the work, which was a purely honorary undertaking.

**Resolutions in Honor of the Late Daniel B. Spear.**

BOSTON, Mass., April 23.—The following memorial from the Boston jewelry trade has been engrossed and transmitted to the family of the late Daniel B. Spear :

A meeting of the wholesale watch and jewelry trade was held April 9, 1894, relating to the death of Daniel Baxter Spear, our respected associate, and with kindly sympathy these resolutions received their unanimous approval.

CHAS. HARWOOD, chairman.  
NATHANIEL L. RIPLEY,  
WM. H. N. PRATT,  
Committee on Resolutions.

*Whereas*, Infinite Wisdom has called our friend from earthly associations, after many months of patient suffering, to a heavenly rest, therefore it is

*Resolved*, That we are grateful to have enjoyed with him so many years of honorable business relations and pleasant social intercourse; and may our sorrow be soothed with the thought that our loss is his eternal gain.

*Resolved*, That we desire to express to those who have known him in a closer relationship our deep and heartfelt sympathy, and wish that the hand of our heavenly Father, with a loving and matchless tenderness, may lift the clouds of sorrow that linger about them in this hour of their sad bereavement and comfort them with the sunshine of His blessed promises.

*Resolved*, That this testimonial, expressive of our sympathy and sorrow, be presented to the family.

**H. T. Spear & Son Find an Assignment Unavoidable.**

BOSTON, Mass., April 21.—Following the announcement of the death of the senior member of the firm comes the decision of the house of H. T. Spear & Son that an assignment is unavoidable, and a circular was issued to all the creditors of the concern today stating that fact.

It appears over the name of Frank L. Cady, Boston representative of Reed & Barton, and sets forth that "Henry T. Spear & Son, having found themselves unable to meet their obligations as they mature, have, in the interest of all concerned, made an assignment to the undersigned of all their property, for the benefit of their creditors."

When seen by THE CIRCULAR correspondent Mr. Cady had not completed the estimates of liabilities and assets which will be laid before the meeting of creditors Thursday, April 26th, at Young's Hotel. In effect, however, the indebtedness is about \$50,000. The assets, reckoned on the showing of the stock book Feb. 1st, this year, are nominally \$50,000 also. An inventory of the assets is to be taken at once.

A. T. Sylvester, the surviving partner, stated that the firm's business was crippled by the death of the elder Spear, some years

since, and the past year had been a severe one for the house to go through. In the trade there is much sympathy expressed, and it is more than probable that the creditors will give the concern a favorable hearing at Thursday's meeting.

**Alfred Selman Dies From the Effects of a Pistol Wound.**

Alfred Selman, the watch exporter, 19 Maiden Lane, New York, who shot himself, in his apartments at the Mendelsohn Club, 113 W. 40th St., last week, died at the New York Hospital, Thursday night, from the effects of his wound. As told in THE CIRCULAR last week, Mr. Selman, whose name was originally Alfred Seligman, was born in Frankfort, Germany, 40 years ago. When a young man he came to this country and shortly after was employed as a clerk with the Gorham Mfg. Co. A year later he entered the employ of Robbins & Appleton as entry clerk, and remained with this house until last year, having advanced to the head of of their export department.

On May 1st, 1893, Mr. Selman started in business for himself as an exporter of watches, at 21 Maiden Lane. He was a nephew of Moses Bruhl, of Bruhl Bros. & Co., 21 Maiden Lane. The funeral was private.

**THE "VIGILANT" HAT BAND.**  
AN INEXPENSIVE NOVELTY.

Detachable  
Hat Band for  
Ladies' Sailor  
Hats, with  
Sterling Silver  
Mountings,  
made in a  
variety of  
attractive  
designs.



Also makers  
and originators  
of the  
popular  
"Duchess"  
Belts,  
together with  
other  
attractive  
Novelties.

THE LATEST ORIGINAL PRODUCTION OF  
**REEVES & SILLCOCKS,** 19 MAIDEN LANE,  
NEW YORK.



# Silver Plated Steel Knives, &c.

## ★ ROGERS & BRO., 12.

SHELL R. E.

SHELL R. E.

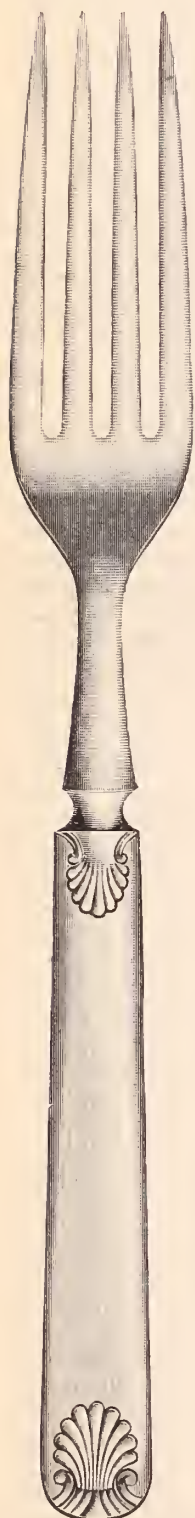

MEDIUM.

YOUR attention is particularly called to our NEW SHELL PATTERN No. 12 Round End Knives and Forks, as hereon illustrated. While costing but 10 cents per dozen extra, the SHELL ornament adds materially to their appearance, and will largely increase the sale of them.

We have discontinued the manufacture of "Steel" Forks and replaced them with a new Nickel Silver Fork, made to match the Round End or Windsor shapes, in Medium and Dessert sizes, prices same as Knives.

### No. 12 SOLID STEEL KNIVES.

### No. 12 NICKEL SILVER FORKS.

ROUND END OR WINDSOR SHAPES.

Plain or Satin, Shell, Plain or Satin, Brocade, Brocade, Old Silver.

### No. 47 PATENTED ALL STEEL KNIVES.

HOLLOW HANDLES.

Plain or Satin, - - Brocade, - - Brocade, Old Silver.

### FRUIT KNIVES.

Plain or Satin, - - Brocade, - - Brocade, Old Silver.

### NUT PICKS.

Plain or Satin, - - Brocade, - - Brocade, Old Silver.

### No. 12 CARVING SETS.—Three Pieces.

SQUARE OR WINDSOR SHAPES.

Brocade, - - - - - Brocade, Old Silver.

## ★ ROGERS & BRO., A-1.

THE ORIGINAL, GENUINE AND CELEBRATED

### STAR ★ BRAND

## Electro Silver Plated Flatware.

# ROGERS & BROTHER,

Waterbury, Conn.

16 Cortlandt Street,  
NEW YORK.

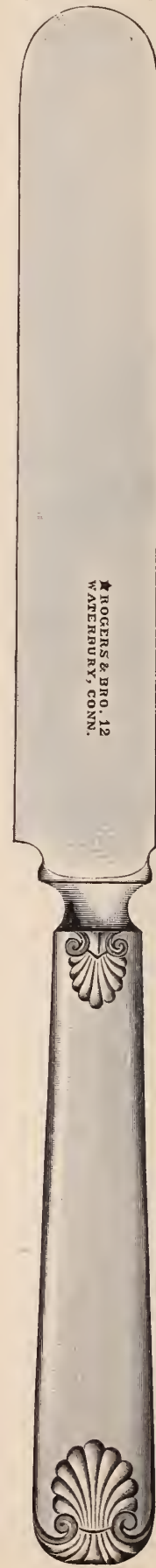

★ ROGERS & BRO. 12  
WATERBURY, CONN.

MEDIUM.



# The Jewelers' Circular

AND  
HOROLOGICAL REVIEW.

PUBLISHED EVERY WEDNESDAY BY  
**THE JEWELERS' CIRCULAR PUB'G CO.,**  
189 BROADWAY, NEW YORK CITY.

A JOURNAL DEVOTED TO THE INTERESTS OF  
JEWELERS, WATCHMAKERS, SILVERSMITHS,  
ELECTRO-PLATE MANUFACTURERS, AND ALL  
ENGAGED IN KINDRED BRANCHES OF INDUSTRY.

Our Editorial columns will contain our own opinions only, and we shall present in other columns only what we consider of interest or value to our readers. Advertising matter will not be printed as news.

Advertising rates in THE CIRCULAR are lower, considering the number of tradesmen reached by its large circulation, than in any other jewelry journal.

Notices of changes in standing advertisements must be received one week in advance; new matter can be received up to Monday.

## INFORMATION FOR SUBSCRIBERS.

### Terms of Subscription, Postage Prepaid.

	PER ANNUM
United States and Canada, . . . . .	\$2.00
Foreign Countries in Postal Union, . . . . .	4.00
Single Copies, . . . . .	.10

New subscribers can commence at any time. Payments for THE CIRCULAR, when sent by mail, should be made in a Post-Office Money Order, Bank Check or Draft, or an Express Money Order or Registered Letter. All postmasters are required to register letters whenever requested to do so.

Pay money only to authorized collectors having proper credentials. Returning your paper will not enable us to discontinue it, as we cannot find your name on our books unless your address is given.

In changing address always give the old as well as new one. Your name cannot be found on our books unless this is done.

We will continue to send papers until there is a specific order to stop, in connection with which all arrearages must be paid; but such an order can be given at any time, to take effect at the expiration of the subscription. All such orders will be promptly acknowledged by mail.

The Courts have decided that all subscribers to journals a responsible until arrearages are paid in full and an order to discontinue has been received by the publisher.

Member of the American Trade Press Association

VOL. XXVIII. April 25, 1894. No. 12.

of the phrase "and among the several States," but this will be a matter of much difference in interpretation. Should the scheme for a national law fail, an effective means to the desired end would be for each State to adopt such laws as are before the Legislatures of Rhode Island, Massachusetts and New York.

### The Same Old Debate.

EVERY now and then the question of wearing jewelry is brought up. A short time ago Grant Allen, whose works are more read than admired, poured out the vials of his wrath upon the practice, a departure which did not meet with much favor, even from his admirers. Recently an English institution had the subject under discussion, when the position taken up by one side was, "That the verdict of mankind from time immemorial is emphatic in favor of jewelry being beautiful, and that it provides employment for numerous workers." The opposition met this by "That the aesthetic taste to which the wearing of jewelry is supposed to minister is of a very low order, and that spending in itself does not tend to provide employment." The formation of the terms of the debate would lead one to imagine that neither of the sides had a vast knowledge of either logic or the jewelry question, and it is gratifying to know that the speakers kept the majority present from voting either way.

### Japan as a Watch Producing Country.

SOME time ago THE CIRCULAR published a dispatch received from San Francisco, in which it was stated that a project was on foot for the establishment of an immense watch manufacturing plant in Japan, which would be designed to give employment to 20,000 hands. While the source of information was reliable, we were inclined to look upon the piece of news as a Munchausenian report; but it now appears there is more truth than fiction in it, if we are to believe the well-known writer on economic subjects, C. Wood Davis, who had the following to say in the New York Sun of April 22d, in the course of a lengthy editorial on Machinery and Industrial Depression: "Swiss watches may have been displaced by better timekeepers made by machinery, but the labor involved in watchmaking has nevertheless been reduced 80 per cent., and the Japanese are now preparing to flood the Western world with watches made by machines operated by labor that thinks itself munificently paid at 20 cents a day." The watch manufacturers and dealers of the United States can not but look upon these statements with great concern, and the benefits arising from the existence of a prohibitive import tariff must be forcibly brought home to their minds. Through the enforcement of the protectionist principle, backed doubtless by native ingenuity, the United States, among the

nations of the world, has become one of the greatest producers of watches, the industry giving employment, under normal commercial conditions, to fully 10,000 persons, all earning wages in good ratio to the value of their services. What will be the results of Japan becoming a large producer of watches, and this country affording no protection to its manufacturers, is a subject for serious consideration. The Japanese are quick to learn and adopt foreign methods, and their well-known dexterity would manifest itself strongly in such delicate manipulations as obtain in the various branches of watch manufacturing. The cost of labor "munificently paid at 20 cents a day" would allow the watches to be sold at a fractional part of the current prices of the American product, and the tariff of 25 per cent. as now exists, would prove trivial and defeat its purpose. The watch manufacturers of the United States should keep their mental eyes peeled to perceive developments in the Japan scheme.

### The Week in Brief.

THE hearing on the "Sterling Silver" bill before the judiciary committee of the House of Representatives of Rhode Island was continued—Alfred Selman, New York, died from the effects of a pistol wound—The United States Supreme Court handed down an interesting decision relating to the duties on opera glasses—The will of the late Hon. Samuel Simpson, Wallingford, Conn., was entered for probate—Charges of fraud were instituted against Adolph Drukler, New York—Charles S. Frantz, Lancaster, Pa., had a serious encounter with highwaymen—A meeting of the Retail Jewelers' Association of New York State will be held—Harris Fellman, Woonsocket, R. I., assigned—Covell & Lamb, Pawtucket, R. I., made an assignment—The plant of Harrington & White, Providence, R. I., was sold out—An interesting suit of the Julius King Optical Co., Cleveland, O., vs. the United States Optical Co., Detroit, Mich., was tried—F. G. Smith & Sons, Detroit, Mich., filed articles of association—Judgment by default was entered against George C. Taylor, of Taylor & Bro., New York—The store of Fesler & Co., Riverside, Ia., was burglarized—Bruhl Bros. & Co., New York, entered suit against the Philadelphia Optical & Watch Co., Philadelphia, Pa.—H. T. Spear & Son, Boston, Mass., made an assignment—A memorial was drafted by the jewelry trade of Boston, Mass., on the death of Daniel B. Spear—The death occurred of Elbert B. Monroe, a member of the old firm of Ball, Black & Co., New York—Proposals are invited for furnishing the Navy Department with silver plated ware—Samuel Goodman and Geo. Barker, charged with robbing H. C. Barnum, traveler for Shafer & Douglas, New York, were held under bonds at Springfield, Mass.—The death occurred of C. A. W. Crosby, Boston, Mass.

As to National Silver Legislation. THE legislative regulation governing the employment of stampings on silverware and analogous manufactures has become a subject of wide discussion in the jewelry trade, and the agitation will in the long run, we hope, have a beneficial sequel. Were it possible for a National law to be enacted providing that goods marked "sterling" shall be at least 925/1000 pure silver, and "coin" shall be 900/1000 pure silver—infraction of the law being punishable by imprisonment and fine—the manufacturer, wholesale dealer, retailer and consumer would be equally protected, and the entire industry would thus come to a state of integrity much desired. But little may be achieved in this direction, for we fail to find in the 18 several powers of Congress any definite ability of the Government to enact such a law. Clause 3d says: "To regulate commerce with foreign nations, and among the several States, and with the Indian tribes." The marking or stamping of silverware may come within the province



### New York Notes.

Seckels & Oppenheimer, importers of diamonds, have removed from 19 Maiden Lane to 45 Maiden Lane.

Wallach & Schiele have satisfied the judgment for \$9,722.41 obtained last December by D. De Sola Mendes & Co.

H. B. Peters, importer and jobber of watch materials, 37 Maiden Lane, will remove May 1st to 177 and 179 Broadway.

J. Vershuur, manager of the importing department of the Wymble Mfg. Co., 39 Union Square, returned from Europe April 15th, on the *Maasdam*.

The Jewelers' & Tradesmen's Co., formerly of 187 Broadway, are now in their new quarters in the Postal Telegraph building, at Murray St. and Broadway.

Lewis F. Williams, said to be a diamond broker of this city, died Friday, of cancer, at his home in Flushing, L. I. He was 67 years old. He leaves one daughter.

The office and factory of Louis Bornemann, manufacturer of diamond jewelry, formerly at 19 John St., is now situated in the Downing building, 106 Fulton St.

Frederick J. Reith, jeweler, of Long Island City, is suing for a divorce on statutory grounds. He married his wife, who was Miss Mattie J. Crissy, last November.

Miss Anna Potter Holder, daughter of the late Chas. H. Holder, for many years a salesman and stockholder in Tiffany & Co., was married April 17th to Daniel H. Burdett, Jr.

S. Valfer & Co., manufacturers of jewelry cases and boxes, who have been for many years at 66 Nassau St., will about May 1st remove their salesroom and factory to the Myers Building, 48 and 50 Maiden Lane.

The final decree in the matter of the assignment of M. Fox & Co., discharging and releasing from liability the assignee, Theo. H. Schultz, and the sureties on his bond, was signed by Judge Bookstaver, of the Court of Common Pleas, April 17th.

Henry and David C. Taylor, who did business under the name of Taylor Bros., pawnbrokers and diamond dealers at 46 Hester St., confessed judgments Wednesday for \$20,021 in favor of Hannah Taylor, and \$5,680 in favor of Annie Taylor on notes and for money loaned.

Among the departures for Europe last week were: Joseph T. Bailey, Philadelphia, Pa., on the *New York*; A. J. Grinberg, New York, and Herman Keck, Cincinnati, O., on the *Campania*; L. Manasse, Chicago, on the *Bretagne*; Theodore Schrader, Chicago, on the *Spruce*.

Augustus Nagle, 24 years old, was held in the Tombs Police Court Thursday in \$1,500 bail for examination on the charge of burglary. The complainant, Ching Chong Heo, a Chinese jeweler at 4 Doyers St., alleged that Nagle broke into his shop and stole goods worth \$57.

L. Straus & Sons will this week remove their cut glass factory from Jay St., New

York, to Hoboken, N. J. Their new factory will be one of the largest and best equipped of its kind in the country. It is 425 feet long, 35 feet wide and contains 80 windows to a floor.

William B. Welsh, son of the late Geo. W. Welsh, who was a prominent retail jeweler at 231 Greenwich St., died in this city Tuesday, April 17th, aged 40 years. Mr. Welsh lived in New Brunswick, N. J., and was the brother of S. Chas. Welsh, the present head of the jewelry firm of Geo. W. Welsh's Son.

A handsome loving cup made by Tiffany & Co., was presented Thursday evening to Francis DeKorbay, the distinguished Hungarian musician, at a farewell reception tendered him at the residence of Judge H. E. Howland, 14 W. 9th St. The cup which is appropriately designed, was intended as an expression of appreciation, and of regret at his departure.

Jacob Friedly, watch case maker and janitor of the building at 75 Nassau St., who is in the Tombs charged with having assaulted his daughter, Lulu, aged 16, last week obtained from one of the judges of the Supreme Court a writ of habeas corpus. He says that the grand jury having failed to indict him, he is entitled to his discharge.

Special Customs Inspectors Brown and Donohue brought to the seizure room at the Barge Office Friday morning a quantity of fine jewelry, valued at \$800, which they had seized. It was taken from two cabin passengers of the *Kaiser Wilhelm*, named D. Ruca and F. Carl, who had attempted the old trick of passing it to a friend upon the dock.

The certificate of incorporation of the Kimberly Diamond Co., 861 Broadway, whose formation was noted in the last issue of THE CIRCULAR, was filed April 14th. The capital stock is \$25,000, divided into shares of \$100 each. The promoters named are Max Goldsmith, 315 E. 30th St.; Hyman Hein, 209 Greene St., and Harry Arnold, 12 Front St., New York.

Judge Coxe, in the United States District Court, Thursday, rendered a decision confirming the finding of Commissioner Mitchell, of the Patent Office, in favor of A. W. Hoffman and against Frederic Ecaubert. Ecaubert claims to have been the first to conceive the idea of a method for ornamenting the peripheries of watch case centres, for which Hoffman obtained a patent.

While driving with a party of friends at East Orange, N. J., last week, Mrs. Frank H. LaPierre was thrown out of her surrey by the horse taking fright at an advertising van, and sustained painful but not severe injuries. Her three companions were also more or less injured, but Mrs. LaPierre is the only one still confined to her bed. Mr. LaPierre has brought an action for damages against the owners of the van which caused the mischief.

Judgment by default for \$24,391 has been entered against George C. Taylor, under the style of Taylor & Bro., formerly an im-

porter of diamonds at 860 Broadway, in favor of the E. Jaccard Jewelry Co., St. Louis, Mo., on 13 promissory notes. In August last two attachments were issued against Mr. Taylor, one for \$7,485 in favor of Frank H. Carpenter, for salary due and money loaned, and the other for \$2,379 in favor of Henry Dreyfus & Co.

In Part I. of the City Court Friday, Justice Newberger heard the suit brought by Simon Leopold who says he is a diamond speculator and broker, against his stock broker, Isaac Borger, for the value of a diamond ring. Leopold testified that after Borger notified him to put up more margin on certain stocks, he offered checks, but Borger refused to accept them or to wait till they could be certified. Then Leopold pulled the ring off his finger and offered it, saying it was good for \$1,000. Borger threw the ring into the crowd and it was lost. The jury gave Leopold a verdict for \$375.

In the trial of Morris Pearlman, of 39th St., South Brooklyn, charged with grand larceny at General Sessions, April 17th, Judge Cowing commented severely on the framing of laws by the Legislature so loosely that citizens having financial difficulties are tempted to use the criminal courts to collect debts. Pearlman was accused of obtaining six watch movements from Simon Harris, a jeweler at 402 Grand St., on July 1st, and giving in part payment a check for \$300 on the State Bank, in this city. The case did not reach a defence, Judge Cowing instructing the jury to acquit Pearlman.

A daring robbery was attempted at the jewelry store of Mrs. T. Lynch, 14th St. and Union Square, Thursday afternoon about 3 P. M. Two young men entered the store and one of them asked to be shown some rings. Clerk Joseph Smith showed him a ruby ring worth \$3,500. He asked to be shown some others and soon had before him a tray containing seven rings. Suddenly the stranger grabbed all the rings and darted into the street. His companion was immediately held by other employes while clerk Smith pursued and captured the thief at 14th St. and Broadway. The prisoner gave his name as James T. Phelps. In the Jefferson Market Police Court later he was remanded in \$3,000 bail for examination.

The tearing down of the buildings at 65 and 67 Nassau St. has been the cause of the following removals: R., L. & M. Friedlander, jobbers in watches, tools, diamonds, etc., to 30 Maiden Lane; W. G. Spaulding, manufacturing jeweler, to 61 Nassau St.; C. G. Buchner, engraver, to 66 Nassau St.; T. J. Dow, manufacturing jeweler, to 82 Nassau St.; Samuel J. Dolbey, stone seal engraver, to 33 John St.; E. H. Seehusen, diamond setter, to 82 Nassau St.; L. H. Crockett, manufacturing jeweler, to 9 Maiden Lane; Henry Kucher, to 61 Nassau St.; A. Horst, diamond setter, to 4 Maiden Lane; A. Munves, maker of jewelry cases, to 75 Nassau St.; and the Estate of John Jacobs diamond dealers, to 9 Maiden Lane.



S. Leopold has entered a judgment against Isaac Borger for \$505.57.

The National Citizens' Bank has entered a judgment against Simon Dessau for \$447.08.

The bond of the assignee of John B. Yates has been approved in the court of Common Pleas, before Judge Bookstaver.

A. J. Comrie, the well-known jewelers' auctioneer, commenced a sale for Hennegen, Bates & Co., Baltimore, Md., on Saturday last.

**President Cleveland Says Mr. Stevens Will Not be Reinstated.**

The report of the committee which went to Washington to endeavor if possible to secure the reinstatement of assistant appraiser Cyrus H. Stevens is as follows:

WASHINGTON, D. C., April 21, 1894.

Your committee, J. B. Bowden, president of the Jewelers' Association; A. J. G. Hodenpyl, president of the Jewelers' Board of Trade; Alfred H. Smith, of Alfred H. Smith & Co., and H. H. Treadwell, of Tiffany & Co., went to Washington and called upon the Secretary of the Treasury Department, who took the matter in hand at once and laid it before the Cabinet meeting, then in session. In the meantime we had called upon the President, and his secretary promised to make arrangements for an interview if possible. Later in the day we received a very courteous letter from the President, who stated that he could not refuse to meet a committee representing such a large and honorable body of merchants, but that, however, the matter of Mr. Stevens had been carefully considered and fully determined upon, and that his reinstatement was absolutely impossible. He made it, however, a point that he would receive us on Saturday morning.

We made this call and urged, if possible, that Mr. Stevens' name might be considered for vacancies which have occurred in that department. We had an opportunity to very fully discuss the subject of the appraiser's department, &c. We feel confident and believe that Mr. Stevens has been removed on account of incorrect statements, which we have tried to correct.

**The Death of C. A. W. Crosby.**

BOSTON, Mass., April 23.—Charles A. W. Crosby, of the jewelry firm of C. A. W. Crosby & Son, died at his residence in this city, yesterday morning, after an illness of several months' duration. Mr. Crosby's career has been an honorable and successful one among the retailers of Boston. He was born at Roque Island, Me., and at the age of 13 years, started out to make his own living. He commenced to learn the jewelry business in Lowell, where he remained six years. He then was two years in Clinton and Leominster, after which he came to Boston. At the age of 21 he formed a partnership with A. F. Burbank, and located on Washington St., between Bromfield and Winter. In 1858, he bought out Mr. Burbank's interest and continued the business alone. In 1877 he removed to the corner of Avon Place, where the present entrance to Jordan, Marsh & Co.'s establishment is located. He later removed to the opposite corner, where the business has ever since been carried on.

In 1889, John D. Crosby having become a member of the firm, the style was changed to C. A. W. Crosby & Son. Mr. Crosby was

also the heaviest stock owner in the Fanueil Watch Tool Co., of which he was treasurer. In 1882 he joined forces with Edward Rivett, inventor of the Rivett lathe and other watch tools, and took a great interest in building up the concern.

Deceased had not been able to attend to business since last Thanksgiving day, and soon after New Year's he was obliged to remain indoors. Cancer of the stomach was the cause of his death. Mr. Crosby was 62 years of age; he was a Mason and Oddfellow. He leaves a son and two daughters. The funeral will take place to-morrow from his residence, 127 Newbury st., at 2 o'clock.

A. J. Benjamin is making extensive alterations in his residence, and is erecting a large new building on Main St., East Greenwich, R. I., which he will occupy as a jewelry store.

The case of Coombs & Atkinson, Pawtucket, R. I., against Joseph B. Patterson was before the Supreme Court Saturday. The plaintiff's demurrer to defendant's plea was overruled and the case assigned for trial on the merits to May 23d.

As D. A. Cook, of the firm of Cook & Martin, Jacksonville, Fla., was closing up his store last Monday night, a lamp exploded, and what might have been a serious matter was averted by Mr. Cook's presence of mind. He threw a cloth over the blazing lamp and picking it up quickly dashed it out on the street.

**L. TANNENBAUM & CO.,**

**Importers and Cutters of DIAMONDS AND PRECIOUS STONES,**

**COR. MAIDEN LANE & NASSAU ST., NEW YORK.**

Telephone, Long Distance, 1959 Cortlandt.

25 HATTON GARDEN, LONDON.

**CABOCHON STONES.**

2 408 1	Cabochon Ruby, 7 8-64 kt., . . . . .	\$18 00 per kt.
15,132 1	" " 2½ 1-32 kt., . . . . .	35 00 "
8,321 1	" " 3⅝ 1-32 kt., . . . . .	15.00 "
28,348 1	" " 1¼ kt., . . . . .	6.00 "
9,420 1	" Sapphire, 4 44-64 kt., . . . . .	14.00 "
21,56 1	" " 3 18-64 kt., . . . . .	10.00 "
1,449 1	" " 1 42-64 kt., . . . . .	10.00 "
23,56 1	" " 3 50-64 kt., . . . . .	6.00 "

**RUBIES.**

1,398	Round Rubies, 202⅜ kt., . . . . .	\$5 00 per kt.
3,245	" " 28 40-64 kt., . . . . .	10.00 "
3,247	" " 79 1-32 kt., . . . . .	3.00 "
12,175	Small " 38 20-64 kt., . . . . .	2.00 "
2,148	" " 63 52-64 kt., . . . . .	3 00 "

**SPINELS.**

15,3 0 1	Spinel, 1 52 64 kt., . . . . .	\$20 00 per kt.
17,107 1	" 3 52 64 kt., . . . . .	20.00 "
8,582 1	" 1 26-64 kt., . . . . .	28.00 "
32,105 1	" 1 61-64 kt., . . . . .	18.00 "

1,391 48	" 21 less 1-64 kt., . . . . .	\$14.00 per kt.
7,591 30	" 9 14-64 kt., . . . . .	10 00 "

**DIAMONDS AND MELEES.**

9	Meles, 50¼ 1 64 kt., . . . . .	\$42.00 per kt.
1.16 1	Fancy Diamond, 2⅜ kt., . . . . .	125.00 "
2.16 1	" " 1½ kt., . . . . .	50.00 "
3 16 1	" " 2 11-64 kt., . . . . .	150.00 "
4.16 1	" " 2 51-64 kt., . . . . .	40.00 "
5.16 1	" " 2 21-64 kt., . . . . .	50.00 "
19 46	" " 7⅞ less 1-32 kt., . . . . .	40.00 "
2,	Melee, 7¾ kt., . . . . .	15.00 "
24	" 59½ kt., . . . . .	38 00 "
25	" 23 less 6-64 kt., . . . . .	10.00 "
47 4	Diamonds, 8 less 1-64 kt., . . . . .	35.00 "
58 15	Brown Diamor ds, 6⅞ less 1-32 kt., . . . . .	30.00 "
59 26	" " 9½ 1-16 kt., . . . . .	25.00 "
88 8	Fancy " 4 54-64 kt., . . . . .	40.00 "
2.90 3	" 6 50-64 kt., . . . . .	50.00 "
3.90 2	" 3 38-64 kt., . . . . .	60.00 "
1 90 1	" ⅜ 3-64 kt., . . . . .	70.00 "
96 4	" 7 less 1-32 kt., . . . . .	50.00 "
96 5	Diamonds, 5 19-64 kt., . . . . .	50.00 "
1,140 35	" 16⅞ 1-32 kt., . . . . .	42.00 "
2,140 43	" 13¾ 5-64 kt., . . . . .	70.00 "



### News Gleanings.

S. B. Strunk has opened a jewelry store in Bath, Pa.

H. W. Dailey has opened a new store in Kennedy, Tex.

Levin & Co. have opened a stock of jewelry and watches in Marengo, Ia.

C. E. Hovey, late of Fredonia, N. Y., has opened a jewelry store in Edinboro, Pa.

C. E. Whitmore, Bar Harbor, Me., has taken the corner store in the Rodick Block.

D. B. O. Scott, jewelers' auctioneer, is selling the stock of Chas. Meinhoefer, Allentown, Pa.

T. W. Gurley is now comfortably located in his new room in the Hocking block, Meyersdale, Pa.

A. Lynde, formerly of Salem, N. J., has opened a jewelry store at 914 Atlantic Ave., Atlantic City, N. J.

The new jewelry store of Wheeler & Sherman, Penn Yan, N. Y., has been opened to the public.

Arthur G. Baker, jeweler and musician, Logansport, Ind., was married to Miss Lillie L. Condon, recently.

W. M. Berry, Pittston, Pa., has enlarged his store room and has added a 4-cent department in house furnishings.

Henry Bachfield's jewelry store at Elwood, Ind., was robbed by burglars of a considerable amount of goods last week.

Polack & Hirt, composed of Augustus Polack and John Hirt, York, Pa., will open a jewelry store in Hagerstown, Md.

Fred D. Ryder, jeweler, Marion, Pa., has bought of Charles B. Blankinship a small building on the corner of Main and Front Sts.

## SAFES FOR JEWELERS.

MOSLER, BAHMANN & CO.,  
518 BROADWAY, NEW YORK.

Patent Fire and Burglar Proof Safes.



Large Assortment Always on Hand.

Send for our Representative.  
Special Safes to Order.  
Jewelers' Safes a Specialty.

LOUIS BORNEMANN,  
MAKER OF Diamond Jewelry,  
Removed to Downing Building,  
106 & 108 Fulton St., N. Y.

The store of Fesler & Co., Riverside, Ia., was entered by burglars last week and about \$200 in gold watches and other jewelry taken.

Fred H. Young, Clinton, Ia., a young watchmaker and jeweler, has decided to embark in business for himself and will open up a new store at once.

The Drummond Co., of La Crosse, Wis., have incorporated to do a retail jewelry business. The capital stock is \$5,000, and the promoters are E. Horner, C. A. Kaepew, and J. C. Drummond.

John Beyett & Bro.'s jewelry store, Alford, Tex., was robbed some nights ago of 14 gold watches. The next morning all the watches were found under the railroad platform.

J. J. Bowerman, a jeweler of Eagle River, Wis., was arrested last week while in the act of breaking into the saloon building of W. H. Knox. He pleaded guilty and was bound over to the Circuit Court for trial.

N. L. Butterweck, Allentown, Pa., has moved his family from 238 N. 7th St., to his store at 41 N. 7th St. His front pane was smashed last Monday night and a quantity of goods stolen. The glass broken was worth \$60.

Henry Robinson has leased the Security bank building, at corner of Noble and 11th Sts., Anniston, Ala., and has opened a new jewelry store. Mr. Robinson has long been a resident of the city, is an experienced dealer and a practical workman.

B. Heyer, Hillsboro, Tex., has executed a deed of trust conveying his stock in trust to W. W. Carter for the benefit of Hayden W. Wheeler & Co., New York, to secure them in the sum of \$1,736.17 His liabilities are \$2,600; assets \$3,000.

W. C. Knuth, of the Helena Lapidary Co., Helena, Mon., has just returned from a trip to the Pacific Coast. The company's exhibit has attracted much attention at the Mid-Winter Fair, and in the show window of Hammersmith & Field, San Francisco.

G. H. Wood, jeweler, Lowell, Mass., announces that he has found his business so pressing on the road in handling a patented invention, that he has not the time to attend to his business at his jewelry store and has decided to close out the whole stock.

Joseph Linz & Bro., Dallas, Tex., have purchased the Randle building, 50x100 ft..

## WINDOW IT PAYS

To trim your window from my new and original illustrations, with full and plain directions for placing in window. Send 50c. Postal Note, Window Designer, P. O. Box 105, Wilmington, Del.

on the corner of Main and Martin Sts., for \$25,000. It is their intention to erect there a beautiful three-story jewelry manufacturing house at a cost of \$40,000, which it is claimed will be one of the finest buildings of the kind in the southwest.

After 16 years of connection in business Einig & Yingling, Defiance, O., have dissolved. John C. Yingling has purchased Mr. Einig's interest in the establishment and will in the future conduct the business. It is understood the retiring partner will sail for Europe about the 1st of May and will spend some time on the Continent traveling and inspecting the watch manufactories.

### St. Louis.

Among the creditors of Aaron Seligsohn, who conducted a dyeing establishment at 1119 Pine St., and who was sold out by the sheriff, were N. Jacobs and Wild Bros., jewelers.

The Retail Jewelers' Association held a meeting a few days ago at 320 Locust St., and a resolution was adopted which will be sent to the Legislature asking for the abolition of night auctions. The association will have a Summer night festival early in June.

J. I. Olsen, Argyle, Wis., writes Chief Walsh that he sent \$5 to the Queen City Plating Co., Jan. 28th, for a silver plating machine, and that he has heard no more about it. J. H. Horn is said by the police to operate the Queen City Co., but the police have never been able to make a case against him, as none of his alleged victims will come to E. St. Louis to prosecute him.

### CHOOSING THE RING.

**O** JEWELER, show me your daintiest rings!  
Have you one that is fit for my darling to wear?

A princess is she, though no daughter of kings,  
And her crown is the wealth of her gold-brown hair.

A diamond? her eyes would out-splendor its glow  
Too glaring and staring, by far, for my queen;  
Or opal? too fickle; an amethyst? no!  
Her blue eyes are bluer than any I've seen.

A ruby? her lips have outwitted us there—  
No ruby would match with the red of their wine;  
A beryl? 'tis fair as the sea's breast is fair,  
But she is still fairer, this darling of mine.

A topaz, that caught from the sun as it ran  
The gold and the glow of its glittering sheen?  
It should only be worn by a masterful man,  
And she is a womanly woman, my queen.

A pearl? it is pure as the soul in her eyes,  
And fair as the foam of the crested wave's curl;  
It is heaven's own type of the peace above price;  
I'll wed my white hily of love with a pearl.

—Marjorie Moore in *Mail and Express*.

CHRYSO-CERAMICS, ~ ~ ~  
GOLD COVERED PORCELAIN.  
M. & E. HEALEY,  
1122 CONNECTICUT AVE., WASHINGTON, D. C.  
MEDAL AT WORLD'S COLUMBIAN EXPOSITION.



NOW ON THE MARKET.

# VANGUARD.

18 SIZE FULL PLATE.

HUNTING OR OPEN-FACE. OPEN-FACE ARE PENDANT SETTING.

The Latest and Greatest Achievement  
in Watchmaking.

Made both REGULAR and NON-MAGNETIC.



**NICKEL;** 17 Extra Fine Ruby Jewels in Raised Gold Settings; Double Roller; Exposed Pallets; Embossed Gold Patent Micrometric Regulator; Compensation-Balance in Recess; Adjusted to Temperature, Isochronism and Position; Patent Safety Barrel; Exposed Winding Wheels; Patent Breguet Hairspring, Hardened and Tempered in Form; Elaborately Finished Nickel Plates with Gold Lettering; Plate and Jewel Screws Gilded; Steel Parts Chamfered; Double Sunk Dial. The Vanguard is the Finest 18 Size Movement in the world.

Manufactured and Warranted by the

# American Waltham Watch Co.,

OF WALTHAM, MASS.



THE STAR OF EMPIRE WESTWARD TAKES ITS WAY

# WESTERN SUPPLEMENT of THE JEWELERS' CIRCULAR

Chicago Office: Room 517, Inter-Ocean Building.

VOL. XXVIII.

CHICAGO, WEDNESDAY, APRIL 25, 1894.

No. 12.

## Chicago Notes.

Clayton B. Shourds, of Shourds & Kasper, is pleasuring in New York.

L. W. Flershem, of Lapp & Flershem, is on a duck hunting trip at Wisconsin lakes.

Manager Farwell, J. B. Chambers & Co., is on a California trip with his wife and mother.

Mr. Alister, of B. F. Norris, Alister & Co., will return from a three months' absence in California about May 1.

W. S. & J. B. Wilkinson will move to their new quarters on the fourth floor of the Masonic Temple the present week.

A. Mayer, representing the German Optical Association at the World's Fair, is again here, this time on a business trip.

G. A. Webster returned Monday from a circuit of largest western cities with favorable reports for silver business, both present and future.

George N. Rouse, for the Geneva Optical Co., has returned from a southern trip and remarks that things look better in the south than in the north.

Sears, Roebuck Co., Minneapolis, Minn., have established a branch at 149 W. Van Buren St., this city. The concern deal direct with consumers.

The new and enlarged salesrooms of C. F. Happel & Co., 84-86 State St., give one the impression that the firm have considerably increased their business facilities.

Charles E. Graves, buyer for J. B. Chambers & Co., accompanied by Mrs. Graves and a party of friends returned Wednesday from a California tour covering four weeks.

Lyman & Co., engravers and etchers, have removed from 96 State St., to room 1313, Columbus building. The room is well lighted by windows overlooking Lake Michigan.

Frank E. Blake, formerly bookkeeper at the Chicago house of the Towle Mfg. Co., has taken the New York territory of the company, under the supervision of the factory, vice Mr. Foote, resigned.

The family of H. D. Parkes, buyer for Lapp & Flershem, will leave May 1 for Lake Paw Paw, Mich. Mr. Parkes will take advantage of Saturday early closing to join his family weekly during the Summer months.

David Quinn, Oconomowoc, Wis., has had made a building of portable construction 14x32 feet, which will be set up in Beaver Dam, Wis., and well stocked with jewelry lines, forming a branch of the Oconomowoc store.

Ed. T. Powers, traveler for the Meriden Britannia Co., is nearing the end of a trip double the length in time of those usually taken—a period of nine weeks to date. The *raison d'être* was that he found good business in points reached in Wisconsin and Michigan.

Kuehne & Kappelman will move May 1st from the Owens building to more central quarters in the Champlain building, N. W. corner State and Madison Sts., providing the construction of the latter building is not retarded beyond that date by the building trades strike.

In these days of political aspirations it is refreshing to hear that John Becks, the well-known Michigan City (Ind.) jeweler, has refused a renomination as Alderman of that city. Mr. Becks has been a City Father there for the past five years and a nomination is equivalent to an election.

B. F. Norris is enjoying the best of health and looks younger than ten years ago. He believes Chicago climate is changing for the better. Since his return from his trip around the world Mr. Norris has not had a day's sickness and seems to have entirely recovered from his former stomach troubles.

Owing to the resignation of chief clerk C. H. Rollins, of the Meriden Britannia Co., to take a position with the Chicago Screw Co., the heads of the office forces have been promoted as follows: W. T. Bogg, formerly bookkeeper, is appointed chief clerk; Geo. Meehan, cashier, becomes head bookkeeper and H. P. Russer, charge clerk, is promoted to cashier. Each is a meritorious advancement.

David Prescott Rowe, eldest son of James L. Rowe, of Rowe Bros., died April 15, at Los Angeles, Cal., of pneumonia. Mr. Rowe left this city April 10 and was taken ill on his arrival at Los Angeles. The doctors did all that could be done but the illness had reached a fatal stage. Deceased was 21 years of age. Mrs. Rowe, the mother, left for Los Angeles on receipt of telegram. The remains will be brought to Chicago for interment.

Robert Smith, of the Geneva Optical Co., has made application for a patent on an extension temple for trial frames that will be found a convenience by all fitters in adjusting the frame so it will sit steady on the 75 face and at the same time give the measurements of the temples. Near the hinge is a graduated sliding scale with screw adjustment which allows the extension or shortening of the temples, to fit a child or the largest face.

The third anniversary of the founding of the Chicago Watchmakers' Institute was celebrated on the 13th inst. with befitting ceremonies. Speechmaking and musical numbers were entertainingly given, followed by the serving of refreshments to the members and their friends. The Chicago Watchmakers' Institute Guild were the hosts of the occasion. Professor Parsons reports eight new members in February, and March showed a further gain of twelve. May 1st, the Institute will move to suite 913, Masonic Temple, the new quarters giving nearly double the present space, and including lecture room and other conveniences. The school is in a flourishing condition and is thoroughly equipped with able and conscientious instructors.

## Burglars Carry Off Booty and Leave no Clue.

MENDON, Mo., April 19—The dry goods and jewelry store of B. F. Fleetwood, at Triplett, was robbed Monday night. About \$100 worth of dry goods and jewelry was taken. The store was entered through the door by means of a key. There is no clue to the robbers.



# JUST OUT!

## Our New Illustrated Catalogue of . . . .

Watch Materials, Tools, & Jewelers' Supplies was issued MARCH 20th.



IF you have not already received a copy notify us and we will send you one at once. We wish to emphasize that our Prices will be found the LOWEST, quality of goods considered. With a well selected stock we are enabled to fill all orders promptly and correctly.

### BENJ. ALLEN & CO.,

141-143 STATE STREET, CHICAGO, ILL.

### Watches, Diamonds, Clocks and Jewelry.

A true CHUCK is the best tool a watchmaker can have, the DALE is invariably true. — ALL KINDS \$1.00. —



MADE ONLY BY

**HARDINGE BROS.,**

1036 LINCOLN AVE., CHICAGO.

## REED & BARTON,

### SILVERSMITHS,

MANUFACTURERS OF

### STERLING SILVER *and* SILVER PLATED WARE.

SALESROOMS :

### 37 Union Square, New York.

34-36 WASHINGTON STREET,

### Venetian Building, Chicago.

FACTORIES, TAUNTON, MASS.

### R. M. JOHNSON,

IMPORTER OF

### Diamonds *and* Manufacturing Jeweler,

67 WASHINGTON STREET,

ROOMS 5 & 6,

CHICAGO.

MASONIC EMBLEMS OF EVERY DESCRIPTION MADE TO ORDER.

## DUEBER-HAMPDEN WATCHES.

The most reliable watches are the Hampden 17 Jewel. A full line of Dueber Cases and Hampden Movements. Cash buyers write us.

### BRETHAUER WATCH & JEWELRY COMPANY,

SPECIAL AGENTS,

71 WASHINGTON ST., CHICAGO, ILLS.

### THE PLANCHAMP & BECKER CO.

Makers and Repairers of

### WATCH CASES,

Gold and Silver Plating —

— of Watch Cases a Specialty.

UNEXCELLED FACILITIES.

83 and 65 East Washington St., Chicago.

WHEN IN CHICAGO, VISIT THE

## Chicago Watchmakers' Institute,

SUITE, 1521-1523 B MASONIC TEMPLE.

A Modern Trade School for the Watchmaker, Jeweler and Engraver.

Write for New Catalogue



### BOLSTAD MFG. AND PLATING CO.,

(H. E. BOLSTAD, PRES.)

WATCH CASE MAKERS, REPAIRERS, PLATERS.  
PLATED INLAYING ON CASES.

BEST WORK. BEST WORKMEN.

170 MADISON ST., CHICAGO.

### ELGIN HOROLOGICAL SCHOOL,

THOROUGHLY PRACTICAL.  
COMPETENT INSTRUCTORS.

Send for Prospectus.

ELGIN, ILL.

### PARSONS : SCHOOL

— FOR —

### WATCHMAKERS,

PEORIA, ILL.

Send for Circular and Terms.

PARSONS & CO.



### Minneapolis and St. Paul.

The I. B. Miller Jewelry Co. still conduct an office in Chicago, at 609, Columbus Memorial building.

A. Lindahl, St. Paul, last week received the nomination as candidate for Alderman on the Republican ticket.

O. H. Arosin, St. Paul, was last week nominated as a candidate for Assemblyman at the Republican city convention.

M. Weinstein, Minneapolis, with his family, left for New York city last week, where he will reside permanently.

D. Stephenson, Minneapolis, has the sympathy of his friends in his recent bereavement in the death of his wife.

M. L. Cohen, Minneapolis, last week erected a large street clock in front of his place of business at 6 Washington Ave. N.

W. H. Chamberlain, Minneapolis, has removed from 36 S. 4th St. to No. 20 same street, into larger and finer quarters.

Robert Reed, of the Reed & de Mars Jewelry Mfg. Co., Minneapolis, is out again attending to business after a brief spell of sickness.

All of the Twin Cities wholesale firms have agreed to close their places of business on Saturdays at 1 o'clock, commencing May 1st, to continue to Sept. 1st.

Sischo & Beard, St. Paul, last week removed from room 242, Endicott building,

into larger quarters, and are now located in Room 714, Manhattan building.

All the retail jewelers in St. Paul have signed an agreement to close their respective places of business during the Summer months at 6.30 P. M. daily, except on Saturdays.

Out-of-town jewelers visiting the Twin Cities the past week were: H. A. Boresson, Ellsworth, Wis.; Herman Fredell, Centre City, Minn.; C. F. Winter, River Falls, Wis.; Wm. Krohn, Annandale, Minn.

Eastern jobbers and manufacturers represented in the Twin Cities the past week were: Meriden Britannia Co., by W. C. Wood; Otto Young & Co., by Mr. Simpson; C. G. Alford & Co., by A. W. Shepard; Mark Streicher & Co., by I. Schwartz; H. Ludwig Co., by Mr. Steinau.

### Detroit.

C. P. Miller, Toledo, O., was in the city last week.

S. Aronsberg, with John Seheidig & Co., spent last week here.

R. J. Roehm is in New York purchasing goods. He will be absent about a week.

H. Weinrich, representing J. A. Schwartz & Co., visited the clothing and jewelry trade here recently.

Mat Delker and Hugh Connolly are taking an optical course under the instruction of Max Riddlescheimer, manufacturing optician.

Albert Schaub has purchased the stock of Robert Glaezner, 209 Gratiot Ave., for \$438. The store is being decorated and restocked with the latest goods.

J. L. Nowey, formerly with J. Hess, New York, has taken the place of J. H. Foster, as expert optician for L. Black & Co. Mr. Foster has established himself at 538 Field Ave.

The following Michigan country jewelers were here last week: Fred Wagner, Monroe; Julius Bates, New Haven; James Ross, Clair; Mr. Knight, Marshall; A. W. Kludt, Lennox; and W. S. Grey, Walled Lake.

Adolph Enggass, jeweler, recently got an execution in the justice's court against W. S. Taft for a jewelry bill, and Constable Gieche seized a buggy in Taft's barn, although George W. Hudson protested and said it belonged to him. Hudson sued Enggass, but the justice last week decided that the constable and not the jeweler was to blame.

F. G. Smith & Sons have filed articles of association. There are 5,000 shares at \$10 a share held as follows: F. G. Smith, Sr., 3,500, Myra J. Smith, 1,000, and F. G. Smith, Jr., 500. A commissioner's sale of the book accounts owned by the bankrupt corporation of F. G. Smith, Sons & Co., was advertised to take place April 17. There was no sale, however, as the chattel mortgage, under which the accounts were to be sold, was entirely satisfied by the proceeds of the sale of the stock

and fixtures. The accounts have been turned over to Assignee Boynton for the benefit of the creditors of the old corporation.

### An Interesting Suit in the Detroit Courts.

DETROIT, Mich., April 21.—The case of the Julius King Optical Co. vs. the United States Optical Co., which is on the Wayne Circuit Court docket is interesting since the point at issue has never been decided in this State.

A short time ago the Detroit firm found itself a creditor of the Tudor Optical Co., of Omaha, Neb., to the tune of \$2,000. A transfer of that firm's stock was made to satisfy the debt. The Julius King Optical Co. were a creditor for \$438, and sue the local concern for the amount claiming that it is liable for the debts of the Tudor Co. As the Omaha firm had a large number of creditors, the suit is in the nature of a test case, having already been carried up from the justice's court. A verdict was given for the plaintiff here.

### Kansas City.

Frank R. Horton will visit Kansas City in a few days for Carter, Sloan & Co.

Alfred S. Stein, of L. H. Keller & Co., New York, was in Kansas City last week.

M. E. O'Donnell was in Kansas City a few days ago representing the Chicago office of Courvoisier-Wilcox Mfg. Co.

D. C. Prudden, optician, has moved his store from 3 W. 10th St., to larger and more convenient quarters at 1017 Walnut St.

The jewelry store of R. E. Dewitt, Baker, Kan., was broken into by burglars a few nights ago and \$500 worth of jewelry and considerable money stolen.

The rooms of the Barr Jewelry Co. were broken into by some young thieves a few nights ago. The boys were soon caught by the police.

The Jaccard Watch & Jewelry Co.'s design for a button for the Kansas State University pupils has been accepted. The button bears the letters "K. U." in gold, on a crimson enameled surface.

William H. Meyer, Lawson, Mo.; Walter Starke, Junction City, Kan.; E. R. Moses, J. R. and E. N. Moses, Great Bend, Kan.; and J. E. Burson, Belton, Mo., were in Kansas City last week buying goods.

Eleazor Hart, of the Hart Jewelry Co., has made a stipulation with Herman Streicher, of the Streicher Watch & Jewelry Co., whereby he agrees to dismiss his suit for damages and the criminal case now pending before Justice Shannon which grew out of slanderous words which Streicher is alleged to have used against Hart. Streicher, on his part, says that he intended no wrong by the words and that he knows of nothing against Hart's good name.

### WAKE UP YOUR CUSTOMERS

WIZARD ELECTRIC ALARM

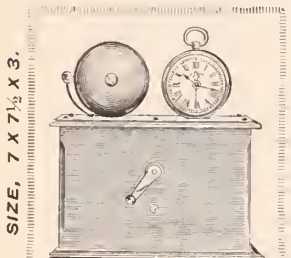

With the new Wizard Electric Alarm Clock. Neat, reliable compact, lowest priced and best Electric Alarm Clock on the market.

#### Special Offer.

We will give you the exclusive agency in your city (if not over 20,000) if you are the first to send in an order, and as long as you sell the cabinets are made of Oak, Cherry and Walnut, Price, \$3.00 net with 5% order, special discount in dozen lots.

R. RUEPING CO., 82 Madison St., CHICAGO.

### PFEIL & OBERNDORF, MANUFACTURING JEWELER.

### Diamond Work a Specialty.

BEST of Workmen.

BEST Design Work.

GUARANTEED Workmanship

Send a trial order and be convinced.

182 State St., Chicago.

HUGO MUELLER,

182 State St., (Room 70,) Chicago.

FINE WATCH REPAIRING

IN ALL ITS BRANCHES.

Work for the trade promptly executed by skilled workmen.



**Rockford.**

P. J. Byrne, foreman of the Rockford Silver Plate Co., has gone to Texas on a pleasure trip.

The Rockford Silver Plate Co. are now running three days of the week and expect to increase the time soon.

Secretary Ed. Knight, of the Rockford Watch Co., will soon commence the erection of a handsome new residence in Riverside.

J. S. Ticknor, president of the Rockford Watch Case Co., is the president of the Rock River Electric Railway Co., recently organized to build a line this Summer between Rockford and Dixon, Ill.

Considerable objection was made to the sharp whistle of the Rockford Silver Plate Co. by the business houses in the locality. The company have replaced it with a new chime, presented them by the Erie Iron Works. The new whistle is immense, being 15 inches in diameter and 38 inches long. The peculiar merit consists in producing three distinct tones pitched to the first, third and fifth of the common musical scale, making a very agreeable musical chord. When applied at full force it can be heard 20 miles.

**Pacific Coast Notes.**

E. C. Brooks, Jacksonville, Ore., is selling out his stock.

Geo. Jordan, San Francisco, advertises to sell out all his fine jewelry and silverware to meet his expenses.

E. S. Brown, of Waltham, Mass., is a new arrival in California and will open a jewelry store in Fullerton in a few days.

**Jewelers' Auctioneer.**



**NEVER A FAILURE.**

References from over 300 Wholesale and Retail Jewelers in all parts of the country. Profits Guaranteed. Correspondence Confidential. Write for terms and details.

501 MASONIC TEMPLE,  
CHICAGO.

Kausen Jewelry Co.'s store, Ferndale, Cal., has been newly repapered and otherwise decorated, and the interior of the store now looks very fine.

L. J. Bennett who has a jewelry store on D St., between 3d and 4th, Marysville, Cal., swore to a complaint, a few days ago, accusing Augustus Mack of grand larceny. It seems that Mack, who had been working for Bennett, skipped town, and since his departure \$137 worth of jewelry has been missed.

Police Sergeant McManus, of Sacramento, Cal., last week received from Folsom Prison a photograph of convict Edwards, one of the men engaged in the Wachhorst diamond robbery a year ago. He immediately recognized the portrait as that of George Edwards, alias Edward J. Hazeltine. Edward went to Sacramento from San Francisco, with a letter of introduction and recommendations from Mike Smith, a politician, to Chief of Police Rogers, and the latter procured him employment on the electric railroad.

... THE ...

**American Horological Institute**

AND TECHNICAL SCHOOL OF LANCASTER, PA.,  
LATE OF PHILADELPHIA, PA.,

A Trade School where Watchmaking is taught practically. We do not manufacture

☼ BICYCLES OR DYNAMOS ☼

at this institute. We confine our work strictly to WATCH WORK and its kindred branches, which include

≡ Engraving, Jewelry Work and Optics ≡

One tuition pays for all the branches. We do not have boy instructors at this institute, all men of years of experience. Each department has its separate instructor. Our institute is open for inspection. We kindly invite you to visit us and inspect our school modes of giving instruction and the progress that our students make by giving them practical instruction.

**THOMAS PENDERGAST,**  
PROPRIETOR AND MANAGER.



The only PERFECT HARDENED GRADUATED MANDREL.

MADE ONLY BY

**W. W. OLIVER, - BUFFALO, N. Y.**

.... Send for our No. 10 Catalogue ....

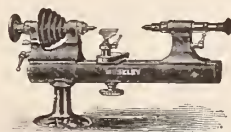

One of the best of the very best.

QUALITY IS THE STANDARD OF VALUE.

CHARGES TO SUIT THE TIMES.

When interested, write your jobber for new price list for 1894, or

**Moseley & Co., Elgin, Ill.**



No. 2 Moseley Wire Chuck has length, strength, accuracy.



**GIBSON HOUSE,**  
CINCINNATI, OHIO.

ABSOLUTELY FIRST-CLASS AMERICAN PLAN HOTEL.

\$3.00 PER DAY.

Extra Charge for Parlors and Rooms with Bath attached. The unequalled advantages in central location, liberal management, modern appointments, experienced service and perfect cuisine, have permanently established the Gibson House as The Most Popular First-Class Hotel in Cincinnati.

AMPLE VAULTS FOR THE PROTECTION OF VALUABLES.

**THE GIBSON HOUSE CO.,**

H. B. DUNBAR

President and Manager



### Cincinnati.

A. Herman is entertaining G. T. Smith, Parkersburg, W. Va.

Sol. Moers, an Arcade jeweler, rejoices in the arrival of a new daughter.

Albert Straussberger, of New York, was the guest of A. G. Schwab last week.

Jonas, Dorst & Co. were closed Saturday on account of the death of Mr. Jonas' mother-in-law.

Muehlmann, Hedges & Co. have lately got out an attachment for the Monarch engraving block for the engraving of the bowls of spoons.

Homan & Co. for the first time this year are experiencing a quiet trade. They are working their men four days a week and will keep them all on hand.

Plaut & Goetheim is the name of the new firm that will open in June, at 169 Race St., for the sale of fancy novelties and jewelry. Both are now connected with A. & J. Plaut. They expect to do a wholesale and retail business.

Lewis M. Braham, for years identified with jewelry interests in Cincinnati, and senior partner in the firm of L. M. Braham & Son, died at his residence from cancer of stomach last Monday. He was buried Thursday. His son will continue the business.

A. Weiler & Co. took a worthless check for \$300 from a man claiming to be J. Winfield, of Shell Mound, Miss., who had purchased a diamond ring and fine gold watch. The draft was returned and Mr. Weiler notified the police, who soon located the man. Upon examination he was found to be insane and was sent to the Sanitarium. Mr. Weiler got his goods and money.

### Cleveland.

Among buyers in the city last week were: White & Son, Wellington, O.; C. M. Con-

verse, Wellington, O.; and McIntosh & Warren, Garrettsville, O.

M. J. Lambert, of Henry Zimmern & Co., New York, was in the city, the past week; also C. W. Gallagher, of Sinnock & Sherrill, New York, and Fred Heffron, of Riley, French & Heffron.

Nearly all of the goods stolen from the Home Security Co. has been found buried in the woods near Painesville. Two of the satchels, filled with valuable watches, were found in a woodchuck hole. The two men under arrest, Geo. Anderson and Chas. Snow, have been bound over to the grand jury.

### San Francisco.

Murry Meyer, formerly with M. Schussler & Co., has gone east.

A. Von Tiederman has moved into a larger store at 314 6th St.

L. P. Jaccard, Livermore, Cal., died recently after a short illness.

J. Spiro, 20 Kearney St., has refitted his store with new side show cases.

Zack Oppenheimer, New York, has been in town showing some fine gems.

A. Goodman, of Goodman Bros., New York, is in town visiting the trade.

J. Steinbach, 1034 Market St., has opened a candy establishment, using half of his store.

Edith Weiman, wife of Gus Weiman, 622 Merchant St., died on April 11th, aged 29 years.

H. W. Kleinenbroich, for many years head watchmaker at Shreve & Co.'s, has opened a store at 1165 Washington St., Oakland.

J. D. Abrams, with Col. A. Andrews, was kept very busy attending to the arrangements of the Mardi Gras, which took place on the 17th, 18th and 19th of April, he being chairman of the committee of arrangements.

The California Jewelry Co. have not made any change in their office as stated in a contemporary, their only change being in their factory which they have given up, Donohue & Kerdell, former employes, having leased it.

### Indianapolis.

S. Margoles, Ligonier, Ind., recently removed to Milwaukee, Wis.

Chas. Kroener, Evansville, Ind., is nicely settled in a new and better location.

C. E. Walker, whose store in Rekey, Ind., was recently burnt out, is again ready for business in new quarters.

At Angola, Ind., Jas. Turley has removed into a more commodious room and F. S. Day has opened a new repair shop.

Jeweler F. M. Herron is president of the Indianapolis Whist Club and is considered the best general player in the city.

Geo. A. Fletcher, Carthage, Ind.; A. R. Cooper, Mooresville, Ind.; and C. M. White, Danville, Ind., made purchasing trips to this city last week.

### Pittsburgh.

Col. Prager, connected with Emanuel De Roy, has gone to Indianapolis to settle up an estate.

G. B. Barrett and family have returned from Cincinnati, where they were summoned by the sad death of Mrs. Susie Barrett Withrow.

Tom Scott, Cadiz, O.; Geo. W. Fisher, Sharon, Pa.; Mr. Mueller, McDonald, Pa.; E. H. Kennerdell, Tarentum, and H. H. Weylman, Kittanning, were in the city last week.

Another retail house will be opened on Frankstown Ave., E. E., shortly. The trend of trade is rapidly approaching the East End, and jewelers are not slow to realize this fact.

# The Wadsworth Watch Case Co.



General Offices,  
NEWPORT, KY.

Filled



Cases.



Chicago Office,  
COLUMBUS BUILDING.



**Connecticut.**

F. H. Brown, Meriden, who has been critically ill, is slowly improving.

George Whitten, the Collinsville jeweler, is closing out his stock of goods at auction.

Peter Busche, New Haven, sailed April 24th for Europe on the *Lahn*. He will be absent about a year.

Timothy Chipman, long established in Cheshire, has retired from business and will hereafter devote his attention to farming.

W. T. Hoyt, employed in the office of the Holmes & Edwards Silver Co., Bridgeport, started April 18th on a European trip.

The Hartford Optical Co., opticians, 144 Asylum St., Hartford, have purchased the spectacle and eyeglass stock of F. E. Burdick.

Thomas Courtney, South Norwalk, has disposed of his jewelry business to Thomas F. Laherly, of New York, who will open May 1st in a store in Hurlbutt's block.

Through an error, it was stated last week that a party named Havalaid had purchased the stock of W. C. Barry & Co., Danbury. The right successors to the firm are M. L. Carter & Co.

Wm. Conlon, of Conlon Brothers, who had an auction store for the sale of jewelry in New Britain, was arrested Wednesday morning for not having a license. They have places also in Ansonia and Waterbury. He was brought before the court and his case was adjourned for one week under \$50 bonds.

The managers of the Westfield Plate Co., Thompsonville, announced April 14 that, as a result of the manifest picking up in business, their works would be operated, beginning the following week, five days a week, ten hours a day, and they confidently expect that within three weeks the works will be running full time with an increased force.

A handsome gate house is being built at Rogers & Brother's factory, Waterbury,

and soon a gateman will be placed there to see how many, if any, of the employes are in the habit of going in late. This is about the last of the big factories in Waterbury that has resorted to the gate house scheme, nearly all of the shops adopting this plan several years ago.

**The "Vanguard" Movement.**

**T**HE progressive spirit of the American Waltham Watch Co. is again potently manifested in the production of a new model, 18 size, full plate watch movement, which has been euphoniously and appropriately christened "Vanguard." The movement has just been put upon the market. A full description of it is given on another page of this issue.

In point of adjustment and finish of all the parts, the Vanguard is superior to any other 18 size movement ever made by the American Waltham Watch Co. Aside from these respects, however, a distinctive feature of this movement is the center jewels. A 17 jeweled grade is a noteworthy addition to the Waltham product, already more extensive than that of any other watch company, and, we reiterate, is another evidence of the progressive spirit which has always been associated with the name Waltham.

Ten samples of the Vanguard were in the Waltham exhibit at the World's Columbian Exposition, and proved of paramount interest to the many jewelers from all parts of the country who visited the Fair, attracting as well by their exquisite finish, the admiring attention of the vast throngs constantly surrounding the exhibits in the horological department of Manufactures building. We, as well as the trade in general, welcome the Vanguard as a movement especially suitable for persons requiring an 18 size watch of great strength and exceptional accuracy of rate.

An open fan is a pretty new silver pen rack.

**HENRY ABBOTT,**  
MANUFACTURER OF  
**Stem-Winding Attachments**  
**FOR WATCHES,**  
No. 2 Maiden Lane, NEW YORK.

**Belts** Send for Samples.  
**AND Buckles.**  
Elegant designs, Prices as low as the lowest. Hair Pins, Link Buttons, Ladies' Combination Shirt Waist Sets and all the latest in **STERLING SILVER NOVELTIES.**  
MANUFACTURED BY  
**CODDING BROS. & HEILBORN.**  
North Attleboro, Mass.  
Chicago office, Buck & Hall, 103 State St., Rm. 802.  
New York office, C. A. Vanderbilt, 173 B'way

**WM. SCHWARZWAELDER & CO.,**  
Fulton St., cor. Pearl, - NEW YORK

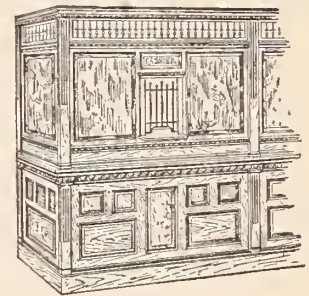

MANUFACTURERS OF  
**DESKS, CHAIRS, Etc.**  
Jewelers' Cases and Counters, Office Partitions, Rails, Etc  
Special Designs, Plans, Prices, etc. upon application.

**DON'T FORGET THE JEWELERS' CIRCULAR PUBLISHING CO.'S BOOK LIST** when in want of any technical book in the Jewelry or Kindred Trades.

**R., L. & M. Friedlander,**



After May 1st, will be located on  
ground floor of

**30 Maiden Lane, N. Y.**

IMPORTERS OF  
**DIAMONDS.**

WHOLESALE  
**JEWELERS.**

JOBBERS IN  
**American Watches.**

We have made great reductions in the prices of Watch Glasses.

SEND FOR PARTICULARS.

SEND FOR OUR NEW CATALOGUE.



**Providence.**

Dutee Wilcox has returned from his trip to Kansas City.

William Loeb has purchased a Summer residence at Riverside.

Stone Bros., New York, were in town making purchases the past week.

E. V. Clerque, of the E. Howard Watch & Clock Co., visited this city the past week.

Albert Krower, of A. Lorsch & Co., New York, was in town the past week.

Horace K. Blanchard has mortgaged real estate on Chalkstone Ave., for \$2,000.

Silas W. Albro has been retained in his position as foreman of the shop of Eaton, Albro & Co.

R. G. Schutz has succeeded John Lamb as the New York and western representative of E. L. Logee & Co.

There is talk of forming a stock company for the manufacture of jewelry at Riverside, R. I., about five miles from this city.

Cards of invitation have been issued for the marriage of David Bernkopf, of Leeder & Bernkopf, at Susquehanna, Pa., on May 2d.

Miss Anna Foster, daughter of Theodore W. Foster, of Foster & Bailey, will be married to Dr. Morrison, of this city, early in June.

It is rumored that C. F. Morrill, of Morrill Bros. & Co., Boston, will purchase the plant of the Seery Mfg. Co., of this city, who failed some weeks ago.

Herman A. Ocker, who has been suffering from the effects of a severe attack of the grip, will leave for Bermuda for several weeks' stay, this week.

David J. White, of the Standard Seamless Wire Co., Pawtucket, has been elected president of the Pawtucket Base Ball Association.

The will of the late John C. Knowles has been admitted to probate by the Municipal Court and Martha D. Knowles has been named executrix, with bonds fixed at \$1,000.

S. & B. Lederer are preparing plans for a new building to be erected upon the property recently acquired by them on Fountain St., wherein they will manufacture silver goods.

Business has taken quite an active boom during the past week, and the general feeling among the manufacturers is that it is a healthy one, and that several weeks of prosperity are about to be vouchsafed to them.

Assignee Henry McKenney will call a meeting of the creditors of M. L. Read & Co. as soon as returns and information are received from the firm's representative at the Mid-Winter Exposition where they have upwards of \$4,000 worth of goods on exhibition and sale.

By the recent renumbering of Richmond St., the following addresses have been changed:—Foster & Bailey, Martin, Copeland & Co., T. Quayle & Co. and Harry

Fulford from 60 to 100; Brown & Dean from 62 and 64 to 104 and 106; Ladd Watch Case Co., Payton & Keiley and L. W. Pierce & Co., from 70 to 118.

New trials were granted last week in the cases of Julius Eichenberg, stone dealer, against Coombs & Atkinson and Coombs & Patterson, manufacturing jewelers, of Pawtucket, upon application of the defendants' attorney, Jacob W. Mathewson. The point was that judgment was taken in the District Court sooner than was proper under the judiciary law.

The entire plant of Harrington & White, including stock, tools, fixtures, etc., at 59 Page St., was sold at public auction Wednesday morning, H. F. Ferrin acting as auctioneer. There was a large number present, but the bidding was dilatory and the property was bid in in a lump by Chas H. Bowen, landlord of the building, for \$570. It is understood that previous to the sale several of the largest creditors met together and decided to accept the offer recently made of 15 cents on the dollar. As soon as a settlement is effected Harrington & White expect to continue business.

The Commissioners of Estimate and Assessment appointed by the Supreme Court in 1892 to assess damages to abutting owners upon the layout and widening of Washington St., have submitted their report which affects several prominent jewelers. Among those reported as losers by the improvement are Dutee Wilcox, \$3,164;

# ROGERS, SMITH & CO.

UNION SQUARE,  
NEW YORK.

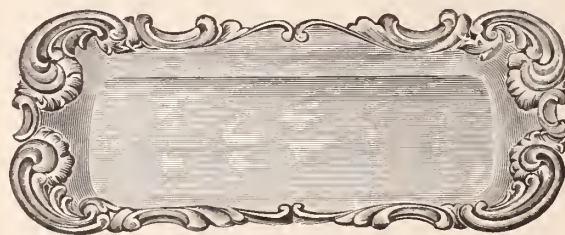

TRINKET TRAY.

MERIDEN,  
CONN.

## GOLD AND SILVER PLATE.



John C. Knowles, \$7,069; while among those who are assessed are John Shepard, Jr., \$193; Isaac H. Southwick, \$417; George H. Wood, \$123; John S. Palmer, \$287; Dutee Wilcox, \$346; Caleb G. Burrows, \$573; S. L. and B. B. Lederer, \$138; William Blakeley, \$254; Callender, McAuslin & Troup, \$96; Thomas Quayle, \$50; Walter S. Hough, \$66.

E. C. Stanley has severed his connection with Coombs & Atkinson, Pawtucket.

J. C. Tucker has started in the manufacture of jewelry in the old Slater Mill, Pawtucket, under the firm style of J. C. Tucker & Co.

About 1,000 names are now on the Gorham Mfg. Co.'s pay roll. Trade is said to be improving, and it is believed that the worst of the business depression is over. The demand for silverware probably will continue.

The new brick block to be erected by Fred Talcott between Beverly and Aborn Sts., and which will be occupied in part by J. B. & S. M. Knowles Co., will be begun shortly. The building will be 99 feet x 51 feet, four stories on the front and three stories in the rear.

### The Attleboros.

Louis Maintien, aged 80 years, died at his home in Plainville Tuesday evening last.

F. L. Torrey and wife have returned from Florida, where they went several weeks ago.

The silver works at Taunton of Reed & Barton are now running full handed, eight hours a day.

The interior of the shop of W. & S. Blackinton has been beautified and thoroughly renovated.

W. B. Ballou has purchased considerable real estate on High St., N. Attleboro, and will soon have a building under way.

Evans, Cobb & Co., Mansfield, received several large orders for jewelry the past week and have started on full time.

George H. Adams, who attempted suicide a fortnight ago, returned to his home in Plainville from the hospital Tuesday last.

The stock of Wm. H. Eaton, the Pawtucket jeweler, was sold in small lots at auction Saturday. Small prices were the rule.

J. L. Sweet, of R. F. Simmons & Co., has been chosen permanent president of the committee in charge of the Bi-Centennial exercises.

E. S. Capron has been chosen a member of the Attleboro school committee, to fill the vacancy created by the resignation of J. L. Sweet.

Fred Dennett, traveling salesman for Reed & Barton, Taunton, will sever his connection with the firm and is to go into business for himself in Trenton, N. J.

The will of the late Handel N. Daggett has been probated in the Court at Taunton

and the extensive property will be divided. The executors are George Asa Dean and Harvey Clapp.

Orville Dean, artist and well-known to the trade as an expert designer, died at his home in Deantown last Thursday. His death was caused by a cold contracted while fighting a fire in the woods that threatened to consume his home. He was in his 56th year and quite vigorous.

Covell & Lamb, manufacturing jewelers, in the Payne building, Broad St., Pawtucket, made an assignment, Thursday morning, to Louis J. Lamb, of Attleboro, for the benefit of their creditors. The firm, which consists of A. E. Covell and W. H. Lamb, succeeded Wm. G. Evans some time ago. They attribute their failure to the depression in business and to the lack of demand for the cheaper grades of jewelry, which they manufactured. The liabilities are estimated at \$3,000, and the assets at less than half that amount. There is a mortgage on the machinery of \$700.

### Lancaster.

Among the traveling men in town the past week were: Chas. Van Ness, Reeves & Sillocks; W. Strauss, Jacob Strauss & Sons; Morris Gugenheim, Marx, Veit & Co.; Mr. Van Olinda, the Wm. L. Gilbert Clock Co.

Thomas Pendergast, proprietor of the American Horological Institute, of this city.

brought suit against F. W. Shuler, of Philadelphia, late an instructor in his employ, charging him with larceny as bailor of \$1,100 worth of tools and materials. The case was tried in last week's court, and the Commonwealth failing to make out a case, a verdict of not guilty was rendered.

Charles S. Frantz had a terrible experience on Sunday night last with footpads. He had been visiting friends in the country and when several miles from the city, near midnight, two men sprang out into the road in front of his team and commanded him to stop. Mr. Frantz gave his horse the whip, but as he passed the highwaymen, one of them fired a shot at him. The jeweler's left arm dropped helpless to his side. The frightened horse soon bore Mr. Frantz out of danger and the wounded jeweler immediately drove to a physician, who found that the bullet had struck one of the bones of the arm, shattering it. The ball was found in the flesh of the arm. The wound is a very painful one and it will be some weeks before Mr. Frantz will have fully recovered.

The Waite, Thresher Co., Providence, R. I., have a line of chameleon rings and other new patterns in gold and sterling silver, new scarf pins, &c., which are going very well.

Battle axes are the coming fad. Thos. W. Lind, Providence, R. I., has them. See his announcement on another page.



Knives,  
Scissors,  
Hairpins,

IN Sterling Silver.

Made in Quantities.

Sold in Quantities.

PRICES AS LOW AS CONSISTENT  
WITH BEST WORKMANSHIP.

Many Novelties in Small Wares.

ALWAYS SOMETHING NEW.

Knives in many patterns from \$6.00 to  
\$12.00 per doz. in doz. lots.

Scissors in all shapes and variety of  
designs, from \$2.00 to \$3.25 each.

J. N. PROVENZANO,  
39 UNION SQUARE, N. Y.





**DIAMONDS.****Wm. S. Hedges & Co.,****Importers of Diamonds,**

And Manufacturers of DIAMOND JEWELRY.

**170 Broadway, New York.**

22 Holborn Viaduct, London.

**R. A. KIPLING,**

Importer of

**PRECIOUS STONES,****21 & 23 Maiden Lane,**19, RUE DROUOT,  
PARIS.

New York.

**NOTICE!****TO MANUFACTURERS**

A WELL-KNOWN Manufacturing House  
visiting the best retail Jewelry trade  
throughout the country, wishes to make  
arrangements with manufacturer of nov-  
elties in Gold Jewelry, to carry in con-  
nection with their line.

Address K.,

Care of Jeweler's Circular.

**Alfred H. Smith & Co.,****IMPORTERS****DIAMONDS**

AND

**PRECIOUS STONES,****182 BROADWAY, COR. JOHN STREET,****NEW YORK.**

23 Holborn Viaduct, London, E. C.

**Canada and the Provinces.**

J. A. Pitts, wholesale jeweler, Montreal,  
is traveling in eastern Ontario.

William Eaves, wholesale jeweler, Mon-  
treal, is in New York selecting stock.

William Orr, jeweler, Alexander, Man.,  
is reported to be moving to Oak Lake.

A. Scott & Co., Montreal, have moved  
their establishment further west on St.  
Catherine St.

E. A. Woodmancey, representing Potter  
& Buffinton, Providence, R. I., was in Mon-  
treal last week.

D. Barton, jeweler, formerly of Cowans-  
ville, Ont., has opened up a store at Point  
St. Charles, Montreal.

George Smith, representing Simpson,  
Hall, Miller & Co., is out on the Pacific  
coast pushing business.

Henry Pierce, wholesale jeweler, Mon-  
treal, has recently returned from a six  
weeks' trip to England and the Continent.

Moody, the Hamilton jeweler, who as-  
saulted Rev. Mr. Bland some days ago, has  
been sentenced to three months in the  
central prison.

Watson & Dickson, jewelers, Notre Dame  
St., Montreal, have dissolved partnership  
and Mr. Dickson continues the business  
under the style of R. A. Dickson & Co.

Mr. Trebilcock, manager of the Canada  
Smelting and Refining Co., London, Ont.,  
is stopping at the Windom, Montreal, for a  
few days.

John Segsworth, Toronto, has failed in  
his appeal to the Court of Appeals against  
a decision in favor of Thomas H. Lee and  
A. C. Anderson, wholesale jewelers. The  
dispute arose over some \$1,500 of the estate  
of Theodore Jorgenson, of Queen St., W.  
Mr. Segsworth will go to the Supreme  
Court.

The American Syndicate of Jewelers'  
Auctioneers are not among the number who  
have reason to complain of the hard times  
or lack of business, as they claim to have as  
much business as they can attend to. Presi-  
dent L. Schieber and his staff of assistants in  
the New York office say they are the busiest  
people on earth and general manager S. A.  
Boyle, at the Washington office, has his  
hands full managing the 22 people they now  
have on the road covering a stretch of coun-  
try from El Paso, Tex., to Buffalo, N. Y.  
Tom Mulinix is making a King B sale in  
Austin, Tex., and Col. Kee is selling for the  
Syndicate at Ortonville, Minn. J. A. O'Dell,  
who has just finished one of the biggest  
sales of the season for the Solomon Jewelry  
Co., Roanoke, Va., is now making a sale for  
a leading jeweler of Holyoke, Mass. Col.  
T. Wilkinson, who has just closed a success-  
ful sale for O. S. Clayton & Sons, Aurora,  
Ill., is now selling the remainder of the  
Nultz stock, Baltimore. C. A. Root is mak-  
ing another notable sale in Parkersburg,  
W. Va., and Lou Mulinix is rolling the dol-  
lars into the till of a leading jeweler of East  
St. Louis, Ill. Other members of the staff  
are doing equally well.

**STERN BROS. & CO.,**

CUTTERS OF

**DIAMONDS,**

WORKS:

29 &amp; 31 Gold Street,

33 to 43 Gold Street,

NEW YORK.

OFFICE,

30 MAIDEN LANE,

NEW YORK.

ESTABLISHED 1870.

**J. L. CLARK,****SWEEP SMELTER AND REFINER OF GOLD AND SILVER**

Buys every kind of Gold and Silverware, Jewelry, Watches and Platinum. Full market value paid.

**No. 724 Filbert Street, Philadelphia, Pa.**

SEND BY EXPRESS or Registered Mail. If my price is not satisfactory, I will return all articles.

A Full Line  
OF ALL  
AMERICAN  
WATCHES.

**MAX FREUND & CO.,**

Importers of Diamonds and Precious Stones,

AMSTERDAM: 8 MAIDEN LANE,  
TULPSTRAAT 9. NEW YORK.

SPECIALTY:

**DIAMOND  
JEWELRY**  
of our own design.



**Fashions in Jewelry and Silver-ware**

A LADY'S RAMBLES AMONG THE JEWELERS.

Silver jewelry of all sorts is coming forward for the Summer.

Mercury wings have been utilized as clasps and very pretty they are.

Stocking supporters with silver catches are produced ready for use.

A dagger of light tinted sapphires at least a foot long has been seen.

Brier wood pipes covered with perforated silver are seen in large numbers.

Tiny pocket books for change with a delicate silver ornament applied are new.

An occasional bow knot is seen ; one, for example, was made of alternating diamonds and olivines.

Slender glass vases, flower shaped and tipped with silver, are among the most attractive of their kind.

A new fruit dish is a large crumpled indented oval, on the bottom of which appears fruit in its natural tints.

New silver cuff buttons of deep blue and red enamel are double and bean shaped, with a tiny silver wreath on the enamel.

Silver receptacles with covers to hold mucilage, cologne, shoe polish and other necessities of life are provided for the Summer traveling season.

The gold enameling on watches is very pretty. This does not refer to the solid enameling, but to the gold surfaces covered with pretty floral ornamentations in enamel.

A set of coffee spoons has on the head of each stem a pansy in a different color. Other spoons have enameled stems enclosing a different flower and rimmed with silver gilt.

A silver star inlaid with turquoise has curving rays. This is new and makes a pretty brooch. A silver crescent about a day old is encircled in the same manner and is very pretty.

The new brooches for women's collars increase in number and variety. They are destined to be popular. The jewelers may count on every school girl eventually making herself the proud possessor of one.

What a dressmaker would call moiré effects are seen in the ornamentation of silver. These are in fact water marks, and look like the condensation outside of an ice pitcher after having been toyed with by the fingers of children.

The new orange cups have appeared in various forms. The original variety had a circular rim with prongs that held the orange in place. Another variety has silver spears at each side that pierce the fruit. Still another has a set of turbine wheel forms in the bottom, with which the orange is screwed and held fast.

ELSIE BEE.

ESTABLISHED 50 YEARS.

**RANDEL, BAREMORE & BILLINGS,**

IMPORTERS OF

**DIAMONDS,**

AND OTHER PRECIOUS STONES.

**FINE PEARLS A SPECIALTY.**

MANUFACTURERS OF

**DIAMOND JEWELRY,**

IN THE LATEST DESIGNS.

Diamonds Recut in Modern Styles or Repaired on Premises.

58 Nassau Street,  
29 Maiden Lane  
NEW YORK.

1 Tulp Straat,  
AMSTERDAM.

1 St. Andrews St.,  
Holborn Circus,  
LONDON, E. C.



TRADE MARK.

ESTABLISHED 1841.

**CARTER, SLOAN & CO.,**

**MANUFACTURERS OF GOLD JEWELRY.**

No. 15 MAIDEN LANE.

NEW YORK.

A. CARTER, JR.  
A. K. SLOAN.  
C. E. HASTINGS.

GEO. R. HOWE  
WM. T. CARTER.  
WM. T. GOUGH.

FACTORY, NEWARK, N. J.



**JOHN N. DISSELKOEN,**  
Cutter and Importer of  
**DIAMONDS**  
FACTORY,  
76 LANGEBLEEKERSPAD  
AMSTERDAM.  
19 East 16th St.,  
NEW YORK.

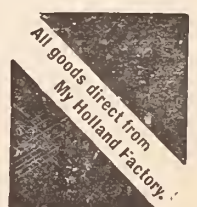



## The World of Invention.

### INDIVIDUAL TEA BALL.

Tea drinkers will appreciate the dainty little novelty illustrated herewith. It is really nothing more nor less than an individual tea ball. For fine caravan teas for instance, where a minute's longer steeping makes a marked difference in the infusion, this spoon will prove invaluable. Filled with tea and inserted in the tea cup of boiling water, one may at will have tea strong or weak. The article is one which will surely find a place at every tea table, and become more popular each day. The Pairpoint Mfg. Co., New Bedford, Mass., are the manufacturers.



### NEW CENTERING APPLIANCE FOR SPECTACLE GLASSES.

The illustration here represents an apparatus used in Queen & Co.'s shops to mark the axis and centers upon cylindrical,

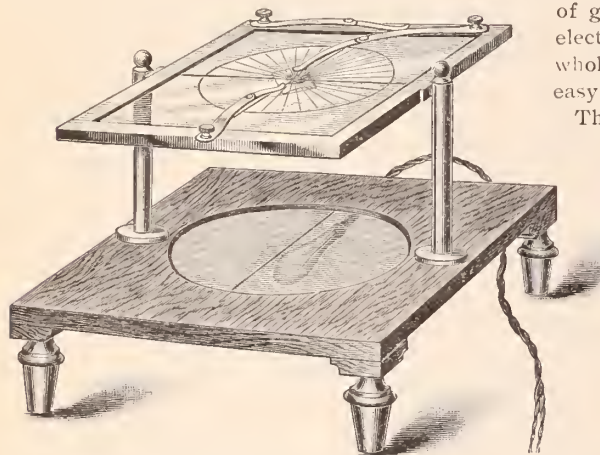

spherical and other lenses. The principle involved in the use of this machine is that

the location of a line when observed through a lens appears changed from its actual position, unless this line is at right angles to a plane or beam of light, which passes through the optical center or axis of the lens to the eye. The usual method of marking these lenses is very crude, and results in many errors, which are greatly objected to by oculists and expert opticians. The error in position of the centers frequently amounts to as much as one fourth inch.

The lens to be centered is laid upon the glass protractor, and secured thereto by one or two arms, which lightly press it to the surface of the plate. The eye then brings the line on the base of the instrument directly under the 90 degrees line of the protractor. The lens is then moved until these two lines are seen in the same position, both above and below the surface of the lens and through it. The 90 degrees line is then traced upon the lens, thus giving the location of the optical axis, if it be a plano-cylindrical. If it be a spherical lens, this line is turned at right angles and another line marked in the same way. The intersection of these lines represents the location of the optical center. In the bed plate of the instrument is placed a disk of ground glass, under which is an electric lamp, which illuminates the whole instrument, and renders it more easy to work.

The device is the invention of E. B. Fox, Queen & Co.'s ophthalmic manager, and a patent has been applied for. Queen & Co. will give a description of the machine and arrange for its use in any optical factory.

All purchasers of three-four lathes and chuck combinations from the Waltham Watch Tool Co., Springfield, Mass., now receive free their new tip over T rest, a most valuable addition. See the announcement on another page.

## Trade Gossip.

E. Kirstein's Sons Co., Rochester, N. Y., want every dealer to send for their Rx list. The firm enjoy special facilities.

Paul Jeanne, 18th St. and Fourth Ave., New York, makes a specialty of fine diamond jewelry and mountings. Work from his hands will always prove satisfactory.

Wm. Birmingham & Co., 728 Arch St., Philadelphia, Pa., make a fine line of leather spectacle and eyeglass cases. Write them when you need anything in this line.

Correspondence is invited by the Providence Shell Works, Providence, R. I., on all tortoise shell orders. Two medals were awarded this concern at the World's Fair.

Albert Bros., Cincinnati, O., have gone into the clock business with a vengeance. They are offering some very fine black enameled wood clocks at prices that are sure to go. Send for their circular.

As manufacturers of jewelry Foster & Bailey have received the highest percentage, 100. At any rate in the renumbering of Richmond St., Foster & Bailey's building has been changed from No. 60 to No. 100.

W. B. White & Son, 90 South St., Boston, Mass., make an eye shade which has won many commendations. The firm also make spectacle and eyeglass cases of every description as well as cases for combs, scissors, etc., etc. See their announcement on another page.

A specially handsome line of silver novelties comprising belts, buckles, hairpins, link buttons, ladies' combination shirt waist sets, etc., is offered by Coddling Bros. & Heilborn, North Attleboro, Mass.; Chicago office, Buck & Hall, 103 State St.; New York office, C. A. Vanderbilt, 178 Broadway.

T. B. Clark & Co., now located at 53 Park Place, New York, will on May 1st move into handsome quarters at 860 Broadway, northeast corner of 17th St. In the display which will be made there, special attention is invited to the Jewel pattern in medium priced and the Carnation pattern in rich cut glass-ware. Secretary and treasurer W. A. Wood will see that the new quarters are put into excellent shape, before his return to the factory.

Any optician would be amply repaid by a visit to the jobbing department of the Spencer Optical Mfg. Co., where he may appreciate the celerity with which a skilled workman assisted by the latest improved machinery, can fill a prescription for simple or compound cylindrical lenses. A few hours after the prescription is received the work is in the mailing department on its way to the sender. This enterprising firm have spared neither time nor money to make this department one of the best in the country. The manner in which the trade appreciates this is shown by the piles of letters and packages going to and coming from opticians in every State in the Union.

## OPTICAL DEPARTMENTS ESTABLISHED.



AN EXPERT OPTICIAN will thoroughly establish an Optical Department in a limited number of FIRST CLASS JEWELRY STORES, giving his own time as promoter until on a successful basis. Will also give complete instructions in fitting to the man designed as head of the department.

### THERE'S MONEY IN IT.

Jewelers wishing to make a special run in their optical department or establish one, will find this a rare opportunity. Your business can be increased \$1,000 to \$2,000 a month. Arrangements can be made either on percentage or salary. An unusual opportunity for a good house to

### ENTER A LUCRATIVE FIELD.

ADDRESS

OPTICIAN, Care JEWELERS' CIRCULAR, Chicago Office,  
308 INTER-OCEAN BUILDING, CHICAGO.



Jewelers and opticians, like every one else, are on the lookout for good and cheap advertising mediums. A very successful scheme was tried by Queen & Co., Philadelphia. It consisted of a thermometer about 4 feet long, with their firm name and address at the top and a cut of a pair of spectacles on the wooden support, together with a statement at the bottom, "Prescriptions Filled," or something of a similar nature. These thermometers were made in quite handsome style and placed in stations, ferry slips, waiting rooms, public meeting places, etc. Several hospitals even were glad to receive them. Queen & Co. have now made arrangements by which they are able to supply them to others with any desired name and advertising matter on them. Their advertisement appears on another page.

**Philadelphia.**

S. C. Davis spent several days on a business mission in New York last week.

Joseph T. Bailey and Mrs. Bailey sailed from New York last Wednesday on an extended tour of Europe.

Gustav Leupelt, 814 Columbia Ave., has been awarded \$450 by the jury of view to assess damages in the change of grade of Columbia Ave. over the Reading Railroad.

Bruhl Bros. & Co. entered suit last week against the Philadelphia Optical & Watch Co. to recover \$13,546.01 as a balance due for merchandise sold and delivered in 1892-93.

C. R. Smith & Son last week commenced a clearance sale of their stock preparatory to the firm's entering upon the general business of manufacturing silver and plated ware.

Albert Halloway was held in \$500 on the 16th inst., on the charge of larceny of several watches and chains from Charles H. Dean, 1521 S. 2d St., which, it is said, he had secured on memoranda.

Isaac C. Toone, trading as Hollinshed Bros. & Co. has sold out the business to Anna M. Hollinshed. The business will

be continued under the old firm name, and managed by Chas. Hollinshed, at 722 Chestnut St.

On Monday a general sale of watches, diamonds, jewelry, silverware, optical goods, safes, fixtures, etc., the effects of the Philadelphia Optical & Watch Co., began at 916 Chestnut St. This was in the interest of the Keystone Watch Case Co. and other heavy purchasers at the sheriff's sale.

A permanent injunction was granted by Judge Reid in Common Pleas on Saturday for the Gorham Mfg. Co. to restrain H. A. Carruthers from representing himself as their agent and obtaining silverware to be replated. The company filed a bill in equity against Carruthers some weeks ago.

Edward J. Farrell, who some time ago in a drunken fit shot at his wife and in the attack wounded jeweler Julius F. Kaufmann, who boarded at the house, was sentenced to seven years' imprisonment on the 17th inst. It will be remembered that Farrell charged that his wife was too intimate with Mr. Kaufmann, but the trial failed to show any evidence whatever to substantiate this assertion.

**Honors to the Late John W. Milford.**

ST LOUIS, Mo., April 20.—A meeting of the local jewelers was called this week to take place April 20th, at the rooms of the M. Eisenstadt Jewelry Co., for the purpose of drafting resolutions and making arrangements to attend the funeral of John W. Milford, manager for the Barbour Silver Co. and Holmes & Edwards Silver Co. The call was signed by Herman Mauch, Morris Eisenstadt, Frank Baier, Ed. Massa, Geo. Stumpf, Rich. Pfeffer and Ed. Boehmer.

The meeting to-day was well attended by local wholesale and retail jewelers. S. A. Rider was made chairman. A committee was appointed to draft resolutions, and another to secure a handsome floral tribute. It was agreed that all persons present would attend the funeral in a body. The memorial adopted is as follows:

**MEMORIAL.**

It has pleased Divine Providence, in His inscrutable wisdom, to remove from amongst us, in the pride and glory of his young manhood, our friend and business associate, John W. Milford. We, the wholesale and retail jewelers of the city of St. Louis, have assembled to express our sorrow and deplore the loss of a member of the trade, whose obliging disposition and close attention to duties have endeared him to our various members, with whom he came in daily contact, and that we will miss his earnest example and honest efforts.

That we extend to his bereaved widow and family our heartfelt sympathy for their irreparable affliction.

That this resolution be published in the various trade journals and a copy sent to the family.

S. A. RIDER, Chairman.

F. H. NIEHEUS, }  
H. MAUCH, } Committee.  
M. EISENSTADT, }

John W. Milford died on Thursday, in his 28th year. He was the youngest son of Clarissa and the late Richard Milford. The funeral will take place to-morrow from the family residence, 3449 St. Vincent Ave., the interment being in Bellefontaine cemetery.

**Correspondence.**

JUDGE COXE'S DECISION IN THE DUEBER SUITS.

NEW YORK, APRIL 23, 1894.

*Editor of THE JEWELERS' CIRCULAR:*

Your last issue contains an item reporting the decision of Judge Coxe to be that the Dueber Co. has no cause of action against the members of the Watch Trust so called, and although it does not contain a single error and is in fact absolutely correct, it is quite misleading as a brief explanation will manifest.

The Dueber Co. brought two actions against the members of the Watch Trust. One to recover damages at common law, that is to say, for injuries caused by acts of defendants in violation of the law as it exists and has existed for centuries. The other action was brought to recover for a violation of an act of United States Congress passed less than four years ago, to wit: July 2, 1890, to punish trusts and monopolies.

The Supreme Court has decided that the common law action is well founded, that is to say, that the acts of defendants as charged are unlawful, and the Dueber Co. entitled to such damage as it has sustained in consequence.

Judge Coxe's decision is confined solely to the act of Congress and he concludes that the law of July 2, 1890, is not broad enough to cover the doings of the watch trust and consequently that plaintiff has no cause of action under that act. We make this explanation particularly because it has been reported in daily papers that the decisions in the two actions conflict. This is by no means true. It suggests a reflection on both courts where it may turn out that both are absolutely correct. It is quite conceivable that if Judge Coxe had been called upon to decide the common law action and Justice Patterson, in Supreme Court, to decide the federal action, the decisions would stand just as they do now.

Judge Coxe in rendering decision from the bench said that he would be pleased to know that the question would be taken to United States Supreme Court, so that the full scope and meaning of the act of Congress might be definitely settled.

We hope in justice to the courts mentioned you will give this explanation or its substance a place in your next issue.

Respectfully,

WILBER & OLDHAM.

Lyons, N. Y., is to have an electric railroad with a capitalization of \$40,000. The power house is to be situated in the northern part of the village, and Orlando F. Thomas, president of the Manhattan Silver Plate Co., is now in New York negotiating in the premises. A new silver plating factory will be erected at the terminus of the line near the power house, and dwellings for the accommodation of laborers will be erected.

**IF YOU WANT A POSITION  
YOU NEED A SALESMAN  
YOU NEED A WORKMAN  
YOU DESIRE TO EXCHANGE  
YOU WANT A PARTNER  
YOU WISH TO SELL OUT  
YOU HAVE TOOLS TO SELL  
YOU HAVE A PLACE TO LET  
YOU WANT ANYTHING**

USE THE

**SPECIAL NOTICE PAGE**

OF THE

**JEWELERS' CIRCULAR,**

Published Every Wednesday.



## Our Traveling Representatives

Traveling representatives may consider these columns open for the publication of any news or items of interest regarding themselves or their conferees.

TRAVELING men calling on Davenport, Ia., jewelers the past

week were: F. R. Horton, Carter, Sloan & Co.; E. E. Parmele, Wilcox Silver Plate Co.; E. W. Strecker, G. E. Luther & Co.; W.

H. Kinna, Elgin National Watch Co.; John E. Ford, Otto Young & Co.

The following traveling salesmen visited Kansas City, Mo., last week: W. S. Willis, Gorham Mfg. Co.; William D. Elcox, Larter, Elcox & Co.

J. Palmer, Palmer, Capron & Co.; H. H. Ingram, Alling & Co.; Ed. Eckfeldt, Wm. B. Kerr & Co.; W. Parks, Parks Bros. & Rogers; A. Levy, Levy, Dreyfus & Co.; and Thos. Campbell, Allioth & Co., were among the traveling men in Philadelphia last week.

Traveling men calling on the Indianapolis trade the past week included: G. H. Linton, F. M. Whiting & Co.; C. B. Bartlett, Whiting Mfg. Co.; J. Guntzburger C. Cottier & Son; H. C. Walton, Wadsworth Watch Case Co.; Geo. D. Munson, Wm. Rogers Mfg. Co.; A. A. Gillett, Heintz Bros.; and representatives of Horton, Angell & Co., Dueber Watch Case Mfg. Co., and Hodenpyl & Sons.

Travelers looking for Chicago business the past week included: George Penn, C. Sydney Smith; N. D. Prentiss, Alling & Co.; C. Le B. Snedeker, E. Aug. Neresheimer & Co.; E. P. Tiffany, F. H. Sadler & Co.; J. J. Summers, Thos. Totten & Co.; J. A. Granbery, Reeves & Sillocks; J. J. Sullivan, W. M. Carr & Co.; Lou Fay, Kirby, Mowry & Co.; Fred Heffron, Riley, French & Heffron; C. O. E. Hartung, Sussfeld, Lorsch & Co.; and Mr. Underwood, Champenois & Co.

Traveling men in Pittsburgh, Pa., last week were: Mr. Blake, Blake & Clafin; W. Hamilton, Meriden Bronze Co.; Hugo Citroen, Vve. L. B. Citroen & Co.; Mr. Braillard, Braillard & Pfingsten; P. Fleischer, Fleischer & Thompson; Mr. Crane, Strobell & Crane; F. C. Winship, T. B. Clark & Co.; N. Coughlin, William Link; W. F. Marlius, J. S. O'Connor; G. A. Henckel, Frank H. LaPierre; C. J. Suplee, Belknap, Johnson & Powell; J. Guntzburger, C. Cottier & Son, Martin Frank & Co.

The following traveling salesmen passed through Detroit last week: G. Rodenburg, S. & B. Lederer; Mr. Gallagher, Sinnock & Sherrill; Fred L. Pettee, Waterbury Clock Co.; William Jarchan, C. F. Rumpp & Sons;

C. O. Hartung, Sussfeld, Lorsch & Co.; Mr. Lampert, Henry Zimmern & Co.; William D. Elcox, Larter, Elcox & Co.; Luther Hyde, Reed & Barton; Henry Wilcox, Wilcox & Evertsen; S. W. Abbey, E. Ira Richards & Co.; Mr. Trewin, Keystone Watch Case Co.; E. P. Tiffany, F. H. Sadler & Co.; C. C. Offerman, Wm. Smith & Co.; Charles Seabury, Rogers & Bro.; Mr. Mayer, Power & Mayer; G. W. Payson, Seth Thomas Clock Co.; M. Stratton, Jr., J. W. Reddall & Co.; and Louis Cook, J. F. Fradley & Co.

Traveling men were numerous in the Hub the past week, among them being: Eugene H. Cox, Sussfeld, Lorsch & Co.; M. Simons, Stern Bros. & Co.; William H. Jones, Larter, Elcox & Co.; H. A. Friese, Lewis, Kaiser & Luthy; Otto Wormser, Henry Dreyfus Co.; Chris. Morgan, Rogers & Bro.; Benjamin Posner, Wallach & Schiele; Mr. Berkeley, Leon J. Glaenger & Co.; Charles S. Isabel, L. Strasburger's Son & Co.; Geo. Paine, E. I. Franklin & Co.; C. E. Hancock, Hancock, Becker & Co., Mr. Lincoln, Reed & Lincoln; Henry G. Thresher, Waite, Thresher Co.; Mr. Ripley, Watson, Newell & Co.; W. A. Bigelow, J. C. Cummings & Co.; Mr. Clarke, Horton, Angell & Co.; Robert Hamilton, Hamilton & Hamilton, Jr.; Mr. Medbury, W. L. Ballou & Co.; Frank Reynolds, Corey & Reynolds.

Among the traveling salesmen in Syracuse, N. Y., the past week were: Alfred Davidson, Harrison Bros. & Howson; S. Standart, H. E. Kirstein's Sons; H. C. Schwartz, Krementz & Co.; B. Weil, S. Valfer & Co.; Max Traub, Herzog, Goldsmith & Frank; O. S. Clark, C. G. Alford & Co.; E. Kubie, Imperial Optical Co.; C. F. Goodwin, Wm. Rogers Mfg. Co.; F. G. Moyer, Max Freund & Co.; Mr. Jeffries, B. L. Strasburger & Co.; Floyd Neely, A. H. Smith & Co.; S. Cohn, Oppenheimer Bros. & Veith; Otto H. Wolf, Bippart & Co.; Charles Cook, W. H. Schwartz & Co.; A. Rutherford, Kirby, Mowry & Co.; Sam'l Baldwin, Baldwin, Ford & Co.; Mr. Barton, R. Wallace & Sons Mfg. Co.; Mr. Paine, E. I. Franklin & Co.; Edwin Beckwith, Julius King Optical Co.; W. E. Major; Mr. Horton, J. B. Bowden & Co.; E. L. Mumford, Waite, Thresher Co.; John Shepherd, Keystone Watch Case Co.; A. M. Stevens, H. Muhr's Sons; F. Thompson, F. Kroeber Clock Co.

### Syracuse, N. Y.

The wholesale jewelry firm of A. Lesser's Sons will remove this week to spacious offices in the *Herald* building.

Eugene B. McClelland will remove to-day from his present quarters on Warren St., to the store in the new Dey building.

Frank D. Enney has removed his stock of goods from 210 Warren St., and established a jewelry store in S. Geddes St.

A. Lewis' wholesale house furnished the handsome gold badge, set with forty-eight diamonds and crowned with a brilliant solitaire of 1½ karats, that was presented

to Alderman Geo. Freeman, of the Seventh ward, by his friends.

### Last Week's Arrivals.

**THE CIRCULAR** has perfected arrangements for obtaining the names and hotel addresses of all the latest buyers visiting New York, and each day posts in its office, 189 Broadway, a bulletin which every member of the trade is cordially invited to copy.

The following out-of-town dealers were registered in New York during the past week: E. P. Sundberg, Fargo, N. D., Astor H.; G. Wolf, Louisville, Ky., Broadway Central H.; J. Floersheim, Chicago, Ill., Belvidere H.; C. E. Child, Warren, R. I., Astor H.; M. Eiseman, Chicago, Ill., Broadway Central H.; H. P. Ayer, Boston, Mass., Barrett H.; J. J. Carr, Boston, Mass., Astor H.; J. Carter, Boston, Mass., Grand Union H.; D. Davis, E. Stroudsburg, Pa., International H.; J. Mack, Philadelphia, Pa., International H.; H. A. Deming, Hartford, Conn., Grand Union H.; W. H. Jones, Columbus, O., Westminster H.; F. Harth, Danbury, Conn., Grand Union H.; L. Hill, Chicago, Ill., Astor H.; A. Illich, Albany, N. Y., Broadway Central H.; J. A. Caldwell, Jr., Philadelphia, Pa., Park Ave. H.

### Points of Law.

#### VALIDITY OF CHECK OF DONOR AS A GIFT

Though a check is not the subject of gift by the maker, because he may stop payment after delivery to the donee, yet where a person gives a check to another with the intention of making a gift to the donee of the amount thereof, the gift becomes complete on payment of the check, and the donor cannot afterwards claim that he gave it under mistake. *Picksley v. Starr*, (Supreme Court, General Term, Second Dep't).

#### VALIDITY OF CONTRACTS.

It is, no doubt, the general rule of law that no right of action can spring out of an illegal contract. And the rule that an illegal contract cannot be enforced applies as well to contracts prohibited as to contracts bad in themselves. But it does not necessarily follow that all the consequences attending a contract which is contrary to public morals or founded on an immoral consideration attend and affect a contract prohibited merely. The law, in the former case, will not undertake to relieve parties from the position in which they place themselves, or to adjust the equities between them. But in the latter case, while the law will not enforce the prohibited contract, it will take notice of the circumstances, and, if justice and equity require a restoration of money or property received by either party there under, it will, and in many cases has given relief. *Winegard v. Fanning*, (Supreme Court, General Term, Third Department.)



**Boston.**

Secretary Rockwell, of the Rogers & Bro. and Meriden Britannia Co. corporations, was a visitor to the Boston trade the past week.

Ex-Foreman Hammond, formerly of the American Waltham Watch factory, and more recently head of Wilson Bros.' repair department, is to occupy the premises vacated by the Bay State Watch Case Co. May 1.

Albert J. Barber, alias Bartlett and Barton, was arrested in Worcester last week and brought to Boston on charges preferred by A. D. Cairns & Co., from whom he obtained watches on leases, and thereafter fraudulently conveyed them to other parties.

A bill has been reported to the Massachusetts Legislature making it a criminal offence for manufacturers or dealers to sell goods stamped or marked "sterling," "sterling silver," "coin" or "coin silver," unless the article so marked is made of a metal containing .925 for sterling and .900 for coin, of pure silver.

Julius Barnott, 179 Court St., was victimized by a snatch thief a few days ago, who entered his store with a request to have some watches shown him and made off with one of the timepieces. He was captured and recognized as the man who did a similar job March 29 in Edward Robins' store at 29 Green St.

**Springfield, Mass.**

Charles D. Rood has been elected president of the Keating Wheel Co., Holyoke.

Patton & Co., the North Adams jewelers, have moved into new quarters in the Davenport block.

Fred S. Todd, of Adams, is remodeling his Myrtle St. store and warehouse and jeweler C. A. Whitman will occupy one of the stores.

A song has just been published by the Phelps Music Co., New York, entitled "The Song of Love," the words to which were written by T. A. Teske, the jeweler.

L. G. Call, Simpson, Hall, Miller & Co.; R. T. Supple, William B. Durgin; and A. Rutherford, Kirby, Mowry & Co., were among this week's visitors to Springfield.

F. A. Hubbard will add a department of optics to his store and has already purchased apparatus. Mr. Hubbard conducted a large department in connection with his Brattleboro store, but was compelled to give it up when it encroached upon his jewelry business. Now he proposes to establish another department which he will conduct personally for a time but which will eventually be placed in charge of a careful optician.

The new candlesticks for tapers are conspicuous, and show the liveliest fancy. One seemingly intended for a nautical person had supports of silver wire bound with silver cables. Others were flower shaped.

**The Latest Patents.**

ISSUE OF APRIL 17, 1894

**518,337. ELECTRIC TOWER CLOCK.** CHAS. D. WARNER, Ansonia, Conn.—Filed April 6, 1893. Serial No. 469,262. (No model.)

In combination with an electric motor mechanism

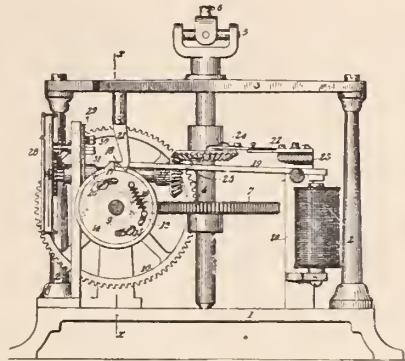

adapted to be operatively connected to the hands of a tower or similar clock, an electric circuit through which to operate the motor, and mechanism for opening said circuit and permitting the motor to run by acquired momentum.

**DESIGN 23,194. SPOON.** HARRY H. CABOT, Bristol, assignor to the Kent & Stanley Co.,



Providence, R. I.—Filed March 8, 1894. Serial No. 502,916. Term of patent 14 years.

**DESIGN 23,195. SPOON.** HARRY H. CABOT, Bristol, assignor to the Kent & Stanley Co., Provi-



dence, R. I.—Filed March 8, 1894. Serial No. 502,917. Term of patent 14 years.

**DESIGN 23,196. SPOON.** GEORGE ROCKWELL, Meriden, assignor to Rogers & Bro., Waterbury,



Conn.—Filed March 12, 1894. Serial No. 503,370. Term of patent 7 years

**TRADEMARK 21,524. JEWELRY ORNAMENTED WITH PRECIOUS STONES, DIAMONDS EXCEPTED.** HORACE R. BENEDICT, New-York, N. Y. Filed Jan. 22, 1894



*Essential feature.*—A monogram composed of the letters "A D," together with the words "ALMANDINE DIAMOND DOUBLET." Used since May, 1893.

**TRADEMARK 21,525. SILVER TABLEWARE.** M. C. EPPENSTEIN & CO., Chicago, Ill. Filed Feb 13, 1894.

**R. COIN.**

*Essential feature.* The letter and word "R. COIN."

Used since September, 1892.

**TRADEMARK 21,526. OPERA-GLASSES.** ARTHUR LEVY, Paris, France. Filed Oct. 10, 1893.

**LA IENA.**

**TRADEMARK 21,538. EYE-WATER.** ANN E. BRADY, New York, N. Y. Filed March 24, 1894.

*Essential feature.*—The words "DIAMOND WATER," in connection with the representation of an eye. Used since February, 1878.

**Expired Patents.**

EXPIRED APRIL 17, 1894; GRANTED APRIL 17, 1877.

**189,600. WATCH-WINDING DEVICES.** W. H. BRACY, Boston, Mass.—Filed Feb. 24, 1877.

As a new article of manufacture, a detachable winding device, consisting of a base, a pipe secured thereto,

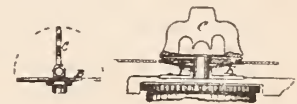

and a thumb-piece pivoted thereon, all arranged and adapted to be applied to the arbor, and contained and folded beneath the outer case of a watch.

**189,619. LINKS FOR ORNAMENTAL CHAINS.** J. J. FREEMAN, Attleborough, Mass., assignor to Freeman & Co., same place.—Filed Feb. 10, 1877.



The chain-link A, formed of wire, bent around, as shown, and having its ends turned inwardly, so as to form two loops a a, and leaving a space, C, between the ends of the wire and the inner surface of the link, sufficient to receive but one thickness of the wire at a time.

**189,785. WATCHMEN'S TIME-DETECTORS** JOSEPH A. J. BREDIER, Paris, France.—Filed Feb. 1, 1877.

1. In a watchman's time-detector, a wheel, H, recessed in the center to receive the dial, and having its periphery toothed and provided with an annular flanged plate to form a series of revolving receptacles or chambers.

**189,797. ORNAMENTAL CHAIN-LINKS.** E. F. SEERY, Providence, R. I.—Filed Feb. 10, 1877.

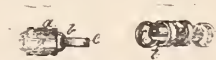

The combination with the open loop b and connecting rings c c, of the sleeve a, made in a single piece.

A convenient silver match holder has two cups united by a panel for the scratching process.

A charming photograph frame has silver rings which hold the photographs like the feathers of a fan.

The prettiest umbrellas have natural sticks with little silver lines and dashes. This is a much prettier style than the solid handles and knobs of silver.

School girls are appropriating hearts of all sizes to string on heart key rings to wear as a bangle. It is appropriate to receive them as gifts, with the names of the givers and dates engraved on the slender sides.



**CLASSIFIED INDEX TO ADVERTISEMENTS.**

All Advertisements are entitled to one insertion under proper heading. Extra insertions, \$6.00 per annum. Extra Headings, \$12.00 per annum.

<b>Art Pottery, Bric-a-brac, Etc.</b>	Page.
Bing, Ferdinand & Co., 106 Grand St., N. Y. . . . .	38
Haviland & Abbot, 29 Barclay St., N. Y. . . . .	38
Healey, M. & E., Washington, D. C. . . . .	16
Hinrichs & Co., 29 & 31 Park Place, N. Y. . . . .	43
Straus, L. & Sons, 42 to 48 Warren St., N. Y. . . . .	37
Vantine, A. A. & Co., 877-79 Broadway, N. Y. . . . .	40
<b>Assayers &amp; Refiners.</b>	
Clark, J. L., Philadelphia, Pa. . . . .	26
Rathbone, J., Providence, R. I. . . . .	37
Schawel, J. & Co., 29 John St., N. Y. . . . .	44
<b>Auctioneers.</b>	
American Syndicate of Jewelers' Auctioneers, New York and Washington . . . . .	2
Lusk, G. W., 501 Masonic Temple, Chicago, Ills. . . . .	21
Prince, J., 137 Broadway, N. Y. . . . .	44
Scott, De B. O., 20 Murray St., N. Y. . . . .	44
<b>Badges, Medals, Etc.</b>	
Stockwell, E. R., 19 John St. N. Y. . . . .	44
<b>Clocks, French, English and American.</b>	
Jacques, Chas., Clock Co., 22 Cortlandt St., N. Y. . . . .	44
<b>Diamond &amp; Precious Stone Importers.</b>	
Disselkoen, John N., 19 E. 16th St., N. Y. . . . .	27
Falkenau, Oppenheimer & Co., 40 Maiden Lane, N. Y. . . . .	44
Hedges, Wm. S. & Co., 170 Broadway, N. Y. . . . .	26
Kipling, R. A., Hays Bldg., N. Y. . . . .	26
Randel, Baremore & Billings, 29 Maiden Lane Smith, Alfred H. & Co., 182 Broadway, N. Y. . . . .	27
Stern Bros. & Co., 30 Maiden Lane, N. Y. . . . .	26
Tannenbaum, L., & Co., cor. Maiden Lane and Nassau St., N. Y. . . . .	15
<b>Diamond Jewelry.</b>	
Jeanne, Paul, Bradley Bldg., N. Y. . . . .	37
Leonhardt & Curran, 44½ Maiden Lane, N. Y. . . . .	43
Louis Bornemann, 106 & 108 Fulton St., N. Y. . . . .	16
Keim, John R., 21 East 17th St., New York . . . . .	4
<b>Fine Stationery.</b>	
Parsons & Greene Co., 18 Murray St., N. Y. . . . .	5
<b>Gold and Silver Plating Works.</b>	
Bolstad Mfg. & Plating Co., Chicago, Ill. . . . .	19
Empire Gold & Silver Plating Co. . . . .	43
<b>Gold and Rolled Plate Jewelry.</b>	
Foster & Bailey, Providence, R. I. . . . .	3
<b>Gold Jewelry.</b>	
Carter, Sloan & Co., 15 Maiden Lane, N. Y. . . . .	27
Johnson R. M., 67 Washington St., Chicago, Ill. . . . .	19
Krementz & Co., 182 Broadway, N. Y. . . . .	43
Pfeil, Chas. H., Chicago, Ill. . . . .	20
Webster, G. A., Chicago, Ill. . . . .	37
<b>Horological Schools.</b>	
American Horological Institute, Lancaster, Pa. . . . .	21
Chicago Watchmakers' Institute, Chicago, Ill. . . . .	19
Elgin Horological School, Elgin, Ill. . . . .	19
Parson's School for Watchmakers, Peoria, Ill. . . . .	19
Philadelphia College of Horology, 623 Heed Building, Phila. Pa. . . . .	42
<b>Hotels.</b>	
Gibson House, Cincinnati, O. . . . .	21

<b>Jewelry, Silverware and Optical Cases</b>	Page.
American Morocco Case Co., 38 E. 19th St. . . . .	2
Steinhaus, Theo. C., 10 Maiden Lane, N. Y. . . . .	43
Valfer, S. & Co., . . . . .	43
<b>Jewelers' Findings.</b>	
Lind, Thos. W., Providence, R. I. . . . .	9
<b>Jewelers' Lamps.</b>	
Hinrichs & Co., 31 Park Place, N. Y. . . . .	36
<b>Jobbers, Watches, Diamonds, Etc.</b>	
Allen, Benj. & Co., Chicago, Ill. . . . .	19
Brethauer Watch and Jewelry Co., Chicago, Ill. . . . .	19
Cross & Beguelin, 17 Maiden Lane, N. Y. . . . .	2
Friedlander, R., L. & M., 65, 67 Nassau St., N. Y. . . . .	23
Freund, Max & Co., 8 Maiden Lane, N. Y. . . . .	26
Myers, S. F. & Co., 48 Maiden Lane, N. Y. . . . .	44
Oppenheimer Bros. & Veith, 35 Maiden Lane, N. Y. . . . .	44
<b>Leather and Silver Goods.</b>	
Deutsch Bros., 7 E. 17th St., N. Y. . . . .	2
<b>Musical Boxes.</b>	
Jacot & Son, 39 Union Square, N. Y. . . . .	2
<b>Office Furniture.</b>	
Schwartzwelder & Co., New York . . . . .	23
<b>Optical Goods.</b>	
McIntire & Ulmer, cor. 8th and Sansom Sts., Philadelphia, Pa. . . . .	8
Queen & Co., Philadelphia, Pa. . . . .	42
Spencer Optical Mfg. Co., 15 Maiden Lane, N. Y. . . . .	38
<b>Optical Schools.</b>	
The Chicago Ophthalmic College, Chicago, Ill. . . . .	22
<b>Paneled Metal.</b>	
Northrop, A. & Co., Pittsburgh, Pa. . . . .	41
<b>Pens, Pencil Cases, Etc.</b>	
The Boston Pen Co., Boston, Mass. . . . .	37
<b>Patents.</b>	
Belt, C. T., Washington, D. C. . . . .	5
<b>Photo-Miniatures.</b>	
Favre, Leon, 107 E. 26th St., N. Y. City. . . . .	37
<b>Platinum Importers.</b>	
Schawel, J. & Co., 29 John St., N. Y. . . . .	44
<b>Ring Makers.</b>	
Bryant, M. B. & Co., 10 Maiden Lane, N. Y. . . . .	37
Bowden, J. B. & Co., 192 Broadway, N. Y. . . . .	7
<b>Safes.</b>	
Mosler, Bahmann & Co., 518 B'way, N. Y. . . . .	16
<b>Sample Trunks.</b>	
Crouch & Fitzgerald, 161 Broadway, N. Y. . . . .	5
<b>Silver Mounted Ebony Goods.</b>	
Deutsch Bros., 7 E. 17th St., N. Y. . . . .	2
<b>Silver Novelties.</b>	
Provenzano, J. N., 39 Union Square, N. Y. . . . .	25
<b>Silver Plated Ware.</b>	
Pairpoint Mfg. Co., New Bedford, Mass. . . . .	5
Rogers, Smith & Co., Meriden, Conn. . . . .	24
Ros & Bro., 16 Courtlandt St., N. Y. . . . .	12

<b>Sterling Silver Novelties.</b>	Page.
Codding Bros. & Heilborn, North Attleboro Mass. . . . .	23
Reeves & Sillocks, Maiden Lane, N. Y. . . . .	11
Sedgwiok, Clarence W., 11 E. 20th St., N. Y. . . . .	4
<b>Sterling Silverware.</b>	
Alvin Mfg. Co., 860 Broadway, N. Y. . . . .	42
Campbell-Metcalfe Silver Co., Providence, R. I. . . . .	2
Knowles, J. B. & S. M. Co., Silversmiths' * Hall, Union Square, N. Y. . . . .	7
Niagara Silver Co., 454 Main St., Niagara Falls, N. Y. . . . .	4
Reed & Barton, 37 Union Square, N. Y. . . . .	19
Towle Mfg. Co., Newburyport, Mass. . . . .	44
Wallace, R. & Sons Mfg. Co., 3 Park Place, Whiting, F. M. & Co., North Attleboro, Mass. . . . .	6
Wood & Hughes, 16 John St., N. Y. . . . .	37
<b>Show Cases.</b>	
Smith, B. & W. B., 220 W. 29th St., N. Y. . . . .	44
<b>Spectacle and Eyeglass Cases.</b>	
Birmingham, Wm. & Co., 728 Arch St., Phila. . . . .	44
White, W. B. & Son, Boston, Mass. . . . .	38
<b>Stem Winding Attachments.</b>	
Abbott, Henry, 2 Maiden Lane, N. Y. . . . .	23
<b>Tortoise Shell Goods.</b>	
Potter, W. K., Providence, R. I. . . . .	
Rice & Hochster, 485 Broadway. . . . .	37
<b>Tool Manufacturers and Dealers.</b>	
American Watch Tool Co., Waltham, Mass. . . . .	37
Bullock, O. W. & Co., Springfield, Mass. . . . .	44
Hardinge Bros., Chicago, Ill. . . . .	19
Logan, A. J., Waltham, Mass. . . . .	5
Moseley & Co., Elgin, Ill. . . . .	21
Oliver, W. W., Buffalo, N. Y. . . . .	21
Waltham Watch Tool Co. . . . .	7
<b>Trunks and Traveling Bags.</b>	
Crouch & Fitzgerald, 161 Broadway, N. Y. . . . .	5
<b>Watch Manufacturers.</b>	
Charmilles Watch. . . . .	43
Waltham Watch Co., Waltham, Mass. . . . .	17
<b>Watch Case Manufacturers.</b>	
Wadsworth Watch Case Co., Newport, Ky. . . . .	24
<b>Watch Case Repairers.</b>	
The Planchamp & Becker Co., Chicago, Ill. . . . .	19
<b>Watchman's Clocks.</b>	
Hausburg, O. E., 41 Maiden Lane, N. Y. . . . .	38
<b>Watch Glasses.</b>	
Fisher & Sons, 63 Nassau St. . . . .	8
<b>Watch Importers.</b>	
Hyde's, J. E., Sons, 22 Maiden Lane, N. Y. . . . .	38
Leon Hirsch, 45 Maiden Lane. . . . .	42
Mathey Bros., Mathez & Co., 21 & 23 Maiden Lane, N. Y. . . . .	7
<b>Watch Keys.</b>	
Clark, A. N., Plainville, Conn. . . . .	43
<b>Watch Repairers.</b>	
Muller, Hugo, Chicago, Ill. . . . .	20



## Special Notices.

Rates 75c. per insertion for notices not exceeding 3 lines (25 words), additional words 2 cents each. If answers are to be forwarded, postage stamps must be enclosed. Two insertions, 15 per cent. off three insertions, 20 per cent. off; four insertions or more, 25 per cent. off. Payable strictly in advance. Display cards on this page will be charged at \$2.00 per inch for first insertion, subject to same discount as above for subsequent insertions.

Under the heading of **Situations Wanted** on this page advertisements will be inserted for **One Cent a Word**. This offer refers to **Situations Wanted only**. Payable strictly in advance. If answers are to be forwarded, postage must be enclosed.

## Situations Wanted.

Notices under this heading **ONLY** are charged at one cent a word, payable strictly in advance. If answer are to be forwarded, postage must be enclosed.

**WANTED, SITUATION**—Manager of a business for two years past. Do all branches of work—watchmaking, engraving, seal making, jobbing, selling, buying. Box 695, What Cheer, Ia.

**WANTED by a first-class watchmaker**, with an excellent equipment of tools, a place in a first-class jewelry establishment, New York or Brooklyn preferred. Samples of workmanship sent for inspection, if required. Reference, E. H. Thrall, 3 Maiden Lane, N. Y. Address W. H., No. 7 Decatur St., Brooklyn, N. Y.

**SITUATION WANTED** as watch and clock maker; also jewelry repairer; age 21; speaks English and German; good references. Address A. Guenther, 875 Sixth Ave., New York.

**ENGRAVER, A1**. Lettering in all its branches. Monograms, ciphers and ornamental work. Also capable of doing copper plate and die cutting for stationery trade. Open for engagement after May 1st. Address J. J. M., care THE JEWELERS' CIRCULAR.

**A1 OPTICIAN AND WATCHMAKER**. About May 1. Charge of optical department in jewelry or optical store, or go on the road. E. T. Smith, 109 Cedar St., Corning, N. Y.

**WANTED AT ONCE**, by a young man of twenty-three a place to complete trade under a good man. Three years' experience at bench; can do ordinary hard solder and clock repairing; also salesman. Best of references. Address H. Bruns, 133 Main St., Columbia, S. C.

**WANTED**.—Position by thorough, practical watchmaker, of seventeen years' experience at the bench; full set of tools. First-class references. Address C., care of THE JEWELERS' CIRCULAR.

**SITUATION WANTED** by young man. Good watch and jewelry repairer. Owns tools and lathe. Best references. Address F. W. S., Box 342, Birmingham, Conn.

**SITUATION WANTED** by a young man. First-class watchmaker. Ten years European experience and six years in this country. Owns tools. Situation in Southern States or California preferred. Address Aug. Lindblad, 2562 Eighth Ave., New York City.

**YOUNG MAN** desiring to complete trade will act as clerk if desired. West preferred. Address F. H. Child, 404 N. Water St., Wichita, Kan.

**SITUATION WANTED** by practical watchmaker and plain engraver; does clock and jewelry repairing if necessary; best of habits and references; have full set of tools; can speak German. Address Reliable, care of THE JEWELERS' CIRCULAR, 517 Inter-Ocean Building, Chicago, Ill.

**POSITION** wanted as bookkeeper; able to superintend; present employers retiring from business. Address F., care of THE JEWELERS' CIRCULAR.

**POSITION** wanted as salesman by a young man of 21 who has been brought up in jewelry store; has fair knowledge of repairing; at best behind the counter; can play musical instruments; good credentials. Address P. O. Box 23, Little town, Pa.

**FIRST class workman** wants situation. Watchmaker, jeweler and letter engraver; owns tools; can furnish A1 references; southwest preferred. State salary. Address Lock Box 595, Pensacola, Florida.

**A GOOD** all round workman wants to make a change. Good watchmaker, engraver and manufacturing jeweler. Hard enamer in all colors. Good on Knight Templar charms, fine badges and diamond mountings. Have the latest tools for all work. Good references. Address Jeweler, 100 Hammond St., Bangor, Maine.

**WANTED**—Position as first-class watchmaker; experience and constant practice of over 20 years in English and American watchmaking and in all fine and complicated work; references and tools. Address Crescent Street, care of JEWELERS' CIRCULAR.

**FIRST-CLASS** practical lapper and polisher wants position; used to all kinds of best diamond mountings; capable of taking charge of polishing department; would go anywhere for good position. Address Practical, 7 Clifton Ave., Newark, N. J.

**SITUATION WANTED** as watch and clock maker; also jewelry repairer; age 21; speaks English and German; good references. Address A. Guenther, 875 Sixth Ave., New York.

## Help Wanted.

**WANTED**.—A salesman traveling through Southern States selling retail jewelry trade to take a side line. Address B., care of THE JEWELERS' CIRCULAR.

**OPTICIAN WANTED**—A retail jeweler eligibly located uptown in New York would let part of store to competent optician. For particulars address Jos. Friedlander & Bro., 21 John St., City.

**SALESMAN WANTED**, well acquainted with the jewelry trade (city and near-by towns), for a special line of jewelry and silverware cases. Apply to A. R., care of JEWELERS' CIRCULAR.

## To Let

**BROADWAY STORE** near the Post Office; desirable location; moderate rent; lease. Apply on premises, 2 Astor House.

**TO LET**—Part of office 15 Maiden Lane; steam heat, also burglar alarm. For particulars apply to Martin, Copeland & Co. 15 Maiden Lane, City

## Miscellaneous.

**I BUY JEWELRY STOCKS**—Manufacturers, jobbers and retailers desiring to dispose of surplus or entire stocks of diamonds, watches and jewelry can find quick cash buyer by addressing Stephen S. Harmon 134 East 96th St., New York City.

**JOBBER** desiring a salesman in Missouri or adjoining States should write to Western Watch Case Agency, Bolivar, Mo.

## DEMAGNETIZING.

**PERFECT WORK**—Watch repairing in all its branches; all work warranted. Winslow & Penney, 608 Masonic Temple, Chicago.

**FOURTEEN karat gold solder** that will flow on eight karat work; makes a hard solder job a pleasure. With this solder there is no danger of melting low karat specs. No white joints on rings. It is just what you want. Sample by mail 25 cents. F. W. Hall, Sterling Silver Novelties, Columbus Memorial Building, Chicago, Ill.

## For Sale.

**FOR SALE**—An old established jewelry store in a city of over 20,000 inhabitants near Boston. Inventory about \$6,000. Address "Snap," care of THE JEWELERS' CIRCULAR.

**JEWELRY STORE** established for 12 years on one of the best business streets of Chicago; stock and fixtures \$5,000; no bonus; stock neat and salable; fixtures modern, including large new safe; annual sales average \$8,000; repairs, \$1,500; expenses, \$1,800, including every item. Just the place for a practical man who is married, as there is space for six living rooms in the rear of store. Outside business is reason for selling. For further particulars address A. Edward, care W. H. Kidwell, 410 Milwaukee St., Chicago, Ill.

**A GENEVA** Lathe, (Triumph except foot wheel; including 20 wire chucks, 20 jewelling and pivot cutters, cement chucks, universal head slide rest, five wheel chucks, etc. Has been used for three or four months; everything in perfect order. Cost over \$100; will sell for \$55. Call or write to O. Roggenkamp, 130 Broad St., Elizabeth, N. J.

**\$900** WILL buy fixtures and stock in best town in Northern, Ohio; two show cases, regulator, bench, safe, shelving and other fixtures. Best location in town of 3,000. Seven factories, electric lights, water works, three railroads. Must sell on account of health. Address Box 72, Caldwell, Ohio.

**JEWELRY STORE FOR SALE**.—I have made my pile and wish to retire from business. A good chance for someone to do as I have done. For particulars address C. H. R. Cheney, Stoneham, Mass.

**FOR SALE**—Previous to removal to 226 Fifth Ave.—two rosewood window cases and fixtures, mahogany office partition and desks. Pickslay & Co., 903 Broadway, cor. 20th St.

**PLAT MILLS AND FOOT PRESS** cheap—a bargain; also cutters. Address E. B. Hayden, 75 Nassau St., Room 14.

**JEWELRY BUSINESS FOR SALE**.—The undersigned as administratrix of the estate of Albert Townsend, deceased, wishes to sell the jewelry store lately carried on by said deceased.

This business was established about 20 years ago, and is well known and has a good repairing trade in connection.

The stock is well assorted and of a kind generally kept in a first-class store of the kind, the fixtures are also of the best.

The store is located in Matteawan, Town of Fishkill, N. Y., which has 13,000 inhabitants, and is the center of business for a large and wealthy farming country.

Terms cash. Call on or address Leila Townsend, Administratrix, Matteawan, Dutchess County, New York.  
LEILA TOWNSEND, Administratrix.

**FOR SALE**.—Rare bargain. One of the best plating shops in Connecticut. Can control a good business. Address Plating, Box 656, Hartford, Conn.

**\$5,000** for long established retail jewelry business in city of 100,000 inhabitants;

**YEARLY PROFIT ABOVE EXPENSE, \$3,500.** Can be greatly increased by additional capital if desired.

Satisfactory reasons for selling given to parties with necessary cash capital. Address, CHANCE care of THE JEWELERS' CIRCULAR.

## FOR SALE.

The Old Established Jewelry Business of G. A. SCHULTZ (Dec'd), is for sale at a great bargain. New fixtures throughout; good location. Address

**HELENA SCHULTZ, Ex'trix,**  
Corner 7th & Market Streets, LOUISVILLE, KY.

## TO LET! PART OF STORE.

**Chas. Jacques Clock Co.**  
22 CORTLAND STREET, NEW YORK.

## Cheap, Bright Offices To Let

singly or in suites, in the handsome new buildings,  
**14 and 45 MAIDEN LANE.**

**Rents \$350 up;** elevator, steam heat, electric lights, etc. **E. A. CRUIKSHANK & CO., 176 Broadway**

## TO LET. FACTORY ROOM WITH POWER.

Elevators, Steam Heat, Watchman, Automatic Fire Sprinklers and good light. Cor. York and Washington Streets, Brooklyn—near the Bridge, within 12 minutes of N. Y. City Hall. For information, apply at Factory, or 198 Broadway, N. Y.

**Ketcham & McDougall.**

## OURAY, COLO.

**FOR SALE.** Jewelry business established six years. Can reduce stock to suit purchaser. \$1,500 to \$2,000 including fixtures. Best location in Colorado. Only fine stock of goods in the county, and no competition to speak of. If you want a good business, and mean business, write. Purchaser can have the sale of my Ouray Souvenir Spoons.

**CHAS. E. ROSE.**



# The Renaissance of Maiden Lane

## INTERESTING CHANGES IN THE LANE AND ITS ENVIRONS.

THE re-birth of the love of beauty which had been killed by long centuries of superstition and bigotry and which found expression in architecture, painting, sculpture and literature was the beginning of the most remarkable era in history, the period of the Renaissance. Such awakenings, of lesser degree and importance, occur in nations, in municipalities. At the present time whole streets and squares of

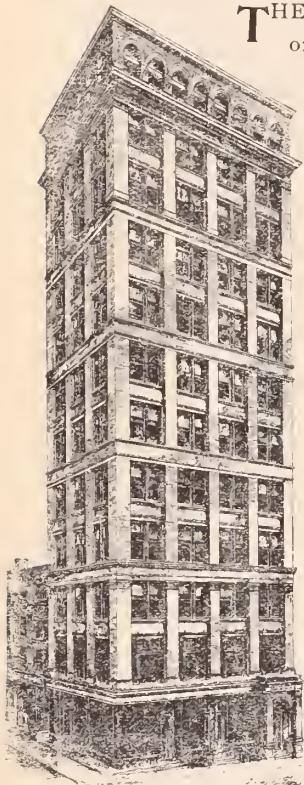

SHELDON BUILDING.

of the city of New York are being re-born, the fervor for building being manifested nowhere stronger than in that portion of the city comprising two or three squares and known as the jewelers' district.

Those of our readers who do business in Maiden Lane and vicinity, long the headquarters of the jewelry trade in New York City, have noted the many radical changes in the appearance of the Lane and the adjoining streets. One needs carry back his recollection but a decade ago to see Maiden Lane with its old-fashioned buildings, many of them almost hoary with age, inconvenient, badly lighted, elevatorless, and dingy. To-day such buildings still remaining may almost be counted on the fingers of one hand while there are to please the eye and render business a pleasure structures like the Stevens building,

the Diamond Exchange, the Corbin building, the Hays building, the Sheldon building, the handsome structure adjoining S. F. Meyers & Co.'s, the Black building and many others, to say nothing of the numerous modernized and remodeled structures. Marvellous indeed would the Lane of to-day appear to the jeweler of the fifties and still more marvellous will it appear in 1900 to the jewelers of six years before.

The Sheldon building, located on the Southeast corner of John and Nassau Sts., has been specially designed and constructed to meet the exacting requirements of the jewelry trade.

The building is 12 stories high, and has a frontage on Nassau St. of 52½ feet and on John St. of 37 feet. The construction is fire-proof, and the iron-work has been designed with special strength to sustain the weight of large jewelry safes. In order to obtain the best advantages of daylight, the windows have been set well out to the face of the building, and have been glazed with the clearest plate glass. The floors are all solid and covered with hard asphalt, no wood whatever having been employed in their construction.

In this building in handsome offices on the first floor are located the firm of Stern Bros. & Co., who to-day occupy the proud position of being the largest cutters of diamonds in this country. This is due altogether to the excellence of the work done by the artisans in the firm's employ, and it is in connection with this firm that one may trace the interesting progress of a diamond from its first stage to its final development. The largest producer of rough diamonds is, of course, the DeBeers Co., which has already been spoken of at length in these columns and the diamond market of the world is London, where a purchasing syndicate takes the rough and disposes of it. By the syndicate the rough is offered to brokers and cutters for either spot cash or on very short time. The purchases made, either direct or through the agency of a broker,

the goods go to the cutting establishments, located to-day principally in Amsterdam and Antwerp where upward of 20,000 men are employed in this industry. When cut and polished the Dutch stones are offered to the trade again through brokers who again receive a commission. As the yearly production of diamonds is estimated at fully \$30,000,000, of which fully 40 or 50 per cent. is purchased by the American market, it will be seen that the numerous commissions enhance the cost of the finished product.

Appreciating this vital fact and aware that American buyers demand the finest workmanship, Stern Bros. & Co. conceived the idea of a monster modern cutting and polishing establishment located in this country where they could produce goods of the high standard required, and at the same time by means of modern machinery and large purchases of rough direct, produce finished goods at a price lower than heretofore possible. Accordingly the present factory premises, at 29 and 31 Gold St., New York, since nearly doubled in capacity, were secured, fitted up by men of experience in the needs of such an establishment, and the product soon convinced buyers here that Stern Bros. & Co.'s work was equal to any produced. Everything in the Gold St. shop is modern and on a scale many times larger than ever before attempted in this country.

The manner and method of cutting and polishing a rough diamond will be of interest.

The first operation is the splitting or cleaving which must be done in order to achieve the best commercial results. It consists, first, in determining on a piece of rough the proper plan and direction for dividing the stone into portions and is an operation calling for the highest skill and judgment coupled with practical experience. Stern Bros. & Co. are fortunate in having in their employ cleavers whose skill is second to none even in the largest European workshops. But to proceed.



# The DIAMOND EXCHANGE

14 MAIDEN LANE -  
New York.

CHAS. F. WOOD & CO.,  
IMPORTERS OF  
DIAMONDS.

C. COTTIER & SON,  
... Importers of ...  
DIAMONDS.  
FANCY GEMS.

CHAS. H. PECKHAM & CO.,  
IMPORTERS OF  
DIAMONDS & PRECIOUS STONES.  
MAKERS OF DIAMOND JEWELRY.  
PARIS OFFICE, 4 Rue Grenier St. Lazare.

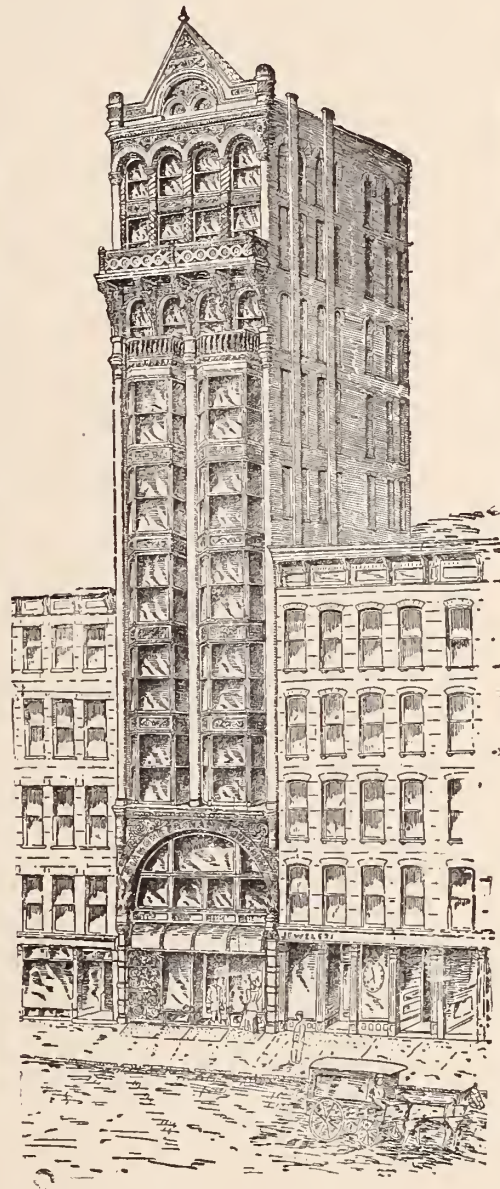

W. & S. Blackinton,  
...OLD RELIABLE...  
W. & S. B. ★ Plated Chains.  
N. Y., 14 Maiden Lane. Factory, Attleboro, Mass.  
Have you seen our New Goods?

S. LINDENBORN,  
IMPORTER OF  
DIAMONDS.

RUBENSTEIN BROS.  
DIAMONDS,  
WATCHES AND JEWELRY.

JULIUS KING OPTICAL Co.,  
WILL OCCUPY THE  
STORE and BASEMENT  
AFTER MAY 1st.



## The Renaissance OF Maiden Lane.

(Continued from page 34.)

The rough stone is embedded in cement and a dull edged diamond drawn across its face. This leaves an indentation which determines the line of cleavage. A sharper and still sharper edged diamond is now passed over the first scratch until the depression made is considered sufficiently deep to admit of the final blow with safety. A sharp steel blade is then placed in the cut and a light sharp blow properly delivered divides the stone as desired.

Now comes the cutting, when the stone receives its general shape. In this again Stern Bros. & Co. are particularly fortunate in that their new and enlarged factory contains machinery especially invented for this purpose, never before used in America and only recently adopted by a few of the largest and wealthiest concerns in Europe. It consists of a modification of the lathe, the stone undergoing cutting being firmly held in a rapidly revolving chuck, and having pressed against it another diamond fastened in an adjustable chuck held in the operator's hands. By deft manipulation the stone gradually assumes form and outline in a manner far superior to that attained by following the old method of rubbing together, by hand.

The stone is now ready for its final beautifying at the hands of the polisher. This workman determines the location of the table and the collet while his assistant, termed a setter, prepares the stone accordingly. The first step is to insert it in a conical mass of partly molten lead, allowing only that particular section which is to be polished to remain exposed. When this lead setting has hardened sufficiently the polisher places the stone against his wheel and the polishing begins. This polishing wheel by the way, running horizontally, flies around at a very rapid rate indeed, those in Stern Bros. & Co.'s factory making 2 300 revolutions per minute. On each wheel there are as a rule about four stones in process of being polished, each being held closely to the grinding surface by means of weights. Each diamond, before being properly polished must be reset a number of times. An excellent feature in the factory of which this article treats is the fact that a given parcel of rough is kept intact during all the various processes just

described and the finished product returned as one parcel.

Stern Bros. & Co.'s force to-day comprises both foreign and American workmen, all of whom are among the best of their kind, with long experience and first-class qualifications. This is necessary in order to produce goods to meet the American demand for the finest goods that can be produced. In the entire mammoth establishment each workman is competent, every mechanical appliance is the best of its kind, and it is only natural, therefore, that the work is equal if not superior to the best from European factories. For some time past the factory has been run to its full capacity, every available polisher in this section, possessing the requisite skill, having been hired. Frequently many of the departments have been run overtime, and finally it was found absolutely necessary to equip another loft. If any more first-class workmen are to be had in this country the firm would like to hear from them.

This is not surprising. Nearly a year ago the factory of Stern Bros. & Co. already employed nearly twice as many hands as all the other diamond cutting factories in this country combined.

S. Lyons & Sons are comfortably established in well-lighted offices on the 3d floor.

In a cosy, well lighted corner office on the eighth floor is the American Turquoise Co., of which J. G. Doty is the sole agent. "It is a conceded fact," said Mr. Doty, "that our turquoise is the only turquoise that is *blue*. It is handled exclusively by such houses as Tiffany & Co., Black, Starr & Frost, Howard & Co., Marcus & Co., Randel, Baremore & Billings and others to whom it has given entire satisfaction. From its greater specific gravity our turquoise is necessarily much less liable to change color by absorption. We have spent a very large amount of money on our mines and have to-day the satisfaction of knowing that they are in perfect shape. Furthermore we have again struck the marvellous vein which yielded those splendid turquoise which first gave our product its present high reputation." In connection with the office is a perfectly equipped lapidist's shop in which one may see the turquoise as mined, assume, under the workman's deft manipulation, that beautiful appearance which commands the admiration of the beholder.

E. Ira Richards & Co. have handsome quarters on the sixth floor.

On the fifth floor are the comfortable

offices of B. Veit, who offers many bargains in watches, diamonds and jewelry. Mr. Veit sells salable goods at bottom prices and cordially invites his customers and the trade generally to call at his new quarters.

The building No. 45 Maiden Lane, has just been remodeled inside and out, equipped with an electric elevator, and is now an ornament to the Lane. On the second floor, in well lighted offices overlooking the street, is located I. Ollendorff, the well-known jobber, whose removal from Pittsburgh to New York city showed the trade what could be accomplished in the way of a complete change in location, after a careful view of all the facts showed such a removal to be in every way advantageous to both dealer and customer. The office is finely fitted up in black walnut, while as handsome a brace of safes of Mosler, Bahmann & Co.'s make, as can be seen in Maiden Lane, take up almost one entire side. Everything has been arranged with an eye to the comfort of the visiting buyer, although Mr. Ollendorff's staff of competent salesmen will doubtless keep customers well stocked. These salesmen and their territories are as follows: In the west, L. Warshawsky; in the east, except New England, W. Bickart; western Pennsylvania and West Virginia, B. Callomon; New England, E. Webber; New York, A. Caro.

In making New York his headquarters Mr. Ollendorff is in position to take advantage of the many opportunities constantly offered a cash buyer in this market. Mr. Ollendorff carries a full line of watches, diamonds and jewelry, and makes a specialty of diamonds and Dueber-Hampden goods. As something that will be appreciated by buyers Mr. Ollendorff offers 500 Columbus movements, 11 jeweled gilt 6 size at \$4 net. In 18 size Columbus Mr. Ollendorff offers 11 jeweled nickel movements, in settings, with patent regulators, for \$4.50 net. In Dueber-Hampden goods Mr. Ollendorff, as agent, carries a complete line, and can talk business with anyone. In American watches the line is second to none, and any honest competition can be met. As soon as things are moving smoothly here Mr. Ollendorff will leave on his regular European diamond purchasing trip, when he will visit Amsterdam, Antwerp, London and other European markets. Buyers here who bear his shrewd purchasing capabilities in mind will await Mr. Ollendorff's return before replenishing diamond stocks.

(To be continued.)





TRADE MARK.

# L. STRAUS & SONS,

IMPORTERS AND MANUFACTURERS,



TRADE MARK

China, Pottery and Glassware, 42, 44, 46 & 48 Warren St. and 116 Chambers St., N. Y.  
PARIS, CARLSBAD, RUDOLSTADT, LIMOGES, STEINSCHONAU.

## The "Bryant" Rings.

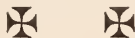

Are widely advertised and will sell when anything will, therefore every Retail Jeweler should buy them.

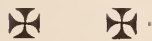

IF NOT CALLED UPON BY OUR TRAVELERS  
ORDER DIRECT FROM

M. B. BRYANT & CO., - 10 MAIDEN LANE, N. Y.

OLDEST RING MAKERS IN AMERICA.



## BIG RETURNS MADE FOR OLD GOLD AND SILVER.

Check Forwarded 24 Hours After Receipt of Consignment.

### J. RATHBONE,

GOLD AND SILVER REFINER, ASSAYER AND SWEEPSMELTER,  
Nos. 1 to 9 Matthewson St., Cor. Cove, Providence, R. I.

\$3.00 FORMERLY \$6.00

Ivory and Enamel Miniatures  
Best Workmanship.



Original Inventor and Patentee of

Miniatures  
—ON—  
Gold and Silver.

PATENTED  
November 12, 1889.

LEON FAVRE, 107 EAST 26TH STREET, NEW YORK.

## VICTOR. ⊗ ⊗

SIMPLEST FEED. ALWAYS THE SAME.  
GUARANTEED FOR ONE YEAR.

### THE VICTOR FOUNTAIN PEN

(Pat. Feb. 4, 1890.)

THE BOSTON PEN CO.,  
N. C. Whitaker & Co., Proprietors.  
363 Washington Street, Boston, Mass.,  
Manufacturers of finest quality  
TORTOISE : SHELL : AND : HORN : GOODS  
in every variety. Also Aluminum Hair Pins.  
Send for Illustrated Pen Price List No. 1.

### WOOD & HUGHES, STERLING SILVERWARE MANUFACTURERS

New York Agents for the Derby Silver Co.'s  
FINE QUADRUPLE PLATED WARE,  
No. 16 JOHN STREET, NEW YORK.  
206 Kearney St., San Francisco, Cal.  
HASKELL & MUEGGE, Agents.

### THE GLOBE PUZZLE.

The LATEST Advertising Novelty. You can positively make from \$20 TO \$50 in cash in your own town with little effort, and procure a large amount of advertising for your own business, free. No risk to run, no investment to make until success is assured. Write quick and procure samples and full information and exclusive control for your town.

D. E. ORVIS & CO.,  
Jerry Rescue Block, SYRACUSE, N. Y.

## G.A. WEBSTER

42 & 44 Madison St., Chicago, Ill.  
Manufacturer,  
AND WESTERN AGENT FOR  
E. G. WEBSTER & SON, of Brooklyn, N. Y.  
A. F. TOWLE & SON CO., of Greenfield, Mass

no jeweler or watch repairer should be without a copy of "WORKSHOP NOTES," a new and very useful book for the workshop. Send for circular containing a complete index of the book, and judge of its merits for yourself.

## Rice & Hochster,

Manufacturers of

TORTOISE

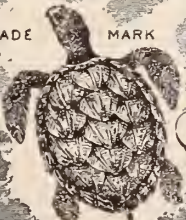

SHELL GOODS

485 BROADWAY, - NEW YORK.



# FERDINAND BING & Co.,

106 GRAND ST., N. Y.

NEW DESIGNS IN

China Clocks and Gilt Bronze Sets, Fine Painted Dresden Goods in Vases, Cups and Saucers, and Plates; Cararra Marble Statuary, French Cabinets and other Fancy Furniture.

NEARLY A CENTURY OLD.

E. GÉRARD, DUFRAISSEIX & CO.,  
SUCCESSORS  
FABRIQUE FONDÉE EN 1797



THE  
CH. FIELD HAVILAND  
LIMOGES CHINA

IS MARKED:

WHITE WARE, **CFH GDM FRANCE**

DECORATED

NEW GLAZE COLORS (FURNACE FIRE), **COULEURS FEU DE FOIE E.G.D.&CO LIMOGES INALTERABLES**

HAVILAND & ABBOT, {O. A. GAGER & Co. CHAS. FIELD HAVILAND & Co.

IMPORTERS OF CHINA,

P. O. Box 505.

29 BARCLAY STREET,

NEW YORK.

AGENTS FOR  
E. GÉRARD, DUFRAISSEIX & CO.,  
LIMOGES.

NEW YORK OPEN STOCK.

We carry at all times a large assortment of the "Chas. Field Haviland" china in white and decorated goods, to repack for immediate shipment or for sale in original casks. Have now sixteen open stock decors and are constantly adding new designs.

IMPORTATION SAMPLES.

The newest and choicest designs always to be found in our import rooms. Novel forms and tasteful decors.

New York Sample Rooms, - - No. 29 Barclay Street.

SWELL AND EYE WIRE SELLS. WE PROTECT THE SWELL BY U. S. PATENT. The Swell also protects the retailer by NOT BREAKING. All our gold frames are BUILT THAT WAY. Look you into our A. B. SEE method of teaching OPTIX. First TUESDAY each month.



MAIDEN LANE 15, CO. MFG. OPTICAL SPENCER.

Jules Jürgensen

OF COPENHAGEN.

The reputation these watches have maintained for Fifty Years has never been equalled, being made on strictly scientific principles and no expense spared to give the Best results in mechanism and timekeeping qualities.

SOLE AGENTS,

John C. Hyde's Sons,  
NO. 27 MAIDEN LANE.

Headquarters FOR ELECTRIC & PORTABLE Watchman's Clocks

Lowest Prices. Latest Improvements. Patents 1886-1893. Send for Circular. E. O. HAUSBURG, 41 Maiden Lane, New York.



Price, Complete \$10.00

THE "ALERT."

WHITE'S EYE SHADE. W. B. WHITE & SON MANUFACTURERS OF



Spectacle and Eye Glass CASES

90 SOUTH STREET, BOSTON.

Special Cases made to order for Optical Trade. Cases for Trial Lenses. Opera Glasses recovered, etc. Chatelaine Spectacle Cases Metal Bound Leather Cases for combs, scissors, etc. Over forty kinds of cases manufactured.

REMOVAL! L. BLACK & CO. 178 BROADWAY,

WILL REMOVE IN APRIL TO THEIR FACTORY, DETROIT, MICHIGAN.





**Chinese Keramics.**

THE latest work on Chinese ceramics is *La Céramique Chinoise* by Ernest Grandidier, an enthusiastic collector of Oriental porcelain, whose collection is of world-wide reputation, and is talked of at Peking, as well as in London and New York. His collection comprises 3,500 pieces, of which only a selection is described and illustrated in the portly volume mentioned.

Stanislas Julien, whose translation from the Chinese of the history of porcelain is well-known, proved that it must have been during the dynasty of the former Han, between B. C. 185 and A. D. 87, when porcelain was invented by the Chinese, because a certain town in the west of China was called *Sin-p'ing* during that dynasty, its name having been changed afterward. But *Sin-p'ing* was also an old name of *Fou-liang*, a great center of the porcelain manufactory to the present day, as may be

seen by referring to the official annals of the T'ang dynasty, and, as the single quotation on which Julien bases his argument was taken from the description of *Fou-liang*, which refers only to the affairs of that district, his argument falls to the ground. So must a great many of the statements in the

same book, for the author never hesitated to translate, although he knew nothing of the special subject.

During the T'ang dynasty there was constant intercourse between Arabia and China, both by sea and land. Chinese junks were seen in fleets in the Persian Gulf. It was through the Arabs that the first porcelain was introduced into Europe. Saladin, after his conquest of Egypt in 1171, sent as a present to Nureddin, Caliph of Syria, forty pieces of Chinese porcelain. In 1295, after a residence in China of twenty-six years, Marco Polo returned to Venice, his native city, and brought with him from Cambalu porcelain vases, we are told among his other treasures. There is a white incense burner in the collection illustrated in the book to which its possessor refers with pride as one of the pieces brought to Europe by the celebrated Venetian. It is described as "a *ting* of octagon shape, ornamented in three horizontal bands, with four s-shaped handles and eight trefoil feet; the cover, which has a pierced decoration, is surmounted at each of its eight angles by a floral knob. The octagonal stand underneath, with an upright border, has also eight trefoil feet and is crowned by eight knobs like those on the cover." The most ancient piece in the famous museum at Dresden comes from the same province of Fuhkien.

Most people talk of soft porcelain in China, referring especially to a finely cracked glaze of ivory-white color, which is either plain or decorated with underglaze blue painting, or even, more rarely, painted with enamel colors. This is made by introducing steatite or soapstone into the paste. If steatite is used in such quantity as to replace the kaolin entirely, the porcelain is very light in weight and of much finer grain than the ordinary kind; otherwise the vase is merely coated outside with a "slip" of prepared steatite. It is more fragile and delicate than usual, and more difficult to fire, but when successful comes out with the painting in blue perfectly clear and well defined, which has been justly compared to a drawing upon vellum as distinguished from one upon common paper.

The collections in the museums of Dresden, Amsterdam, Sèvres, and Limoges are described in the book as consisting mainly

of productions specially made for the European market during a limited period, and the author observes how people wondered at the beauty of the purely Chinese pieces that arrived after the pillage of the Summer Palace in Peking in 1860. The cabinets of America and England are, it is confessed, richer in Chinese things. The American is said not to hide his preference for the Sung and Yuan epochs, to love the refined fabrication of the eighteenth century; but

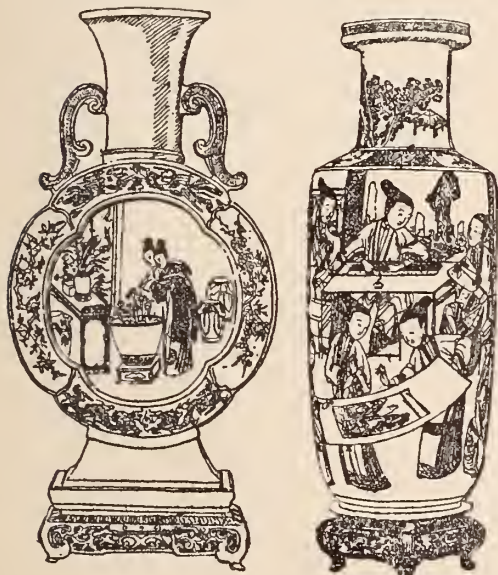

VASE OF "PRETTY WOMEN."

VASE OF THE POLITE ARTS.



VASE REPRESENTING THE TAOIST TRIAD.

to be impelled by a veritable passion for single colors which he would like to monopolize for his exclusive profit. In illustration of this we are told how a peach-bloom vase was bought in China seven years ago for about 600 francs, was sold in New York for 75,000 francs, and how, after the recent death of its lady owner, it had recently fetched 90,000 francs at public auction.

There is nothing so artistically decorative as the brilliant blue and white porcelain of the reign of K'ang-hsi, the culminating epoch of Chinese ceramic art. It is preserved from ordinary wear and tear under a thick transparent coating of glaze, which the color, painted as it was upon the unbaked paste, penetrates in varied intensity and tone, and for that reason it is impossible to reproduce it by photographic processes without blurring.

There is a most useful chapter on the usual subjects of the designs, with notes on the three chief religions, symbols and emblems, scenes of romance, history, and the like, followed by another on the use for



### The Connoisseur.

(Continued from page 39.)

which the vases and pieces of different forms were intended. The Taoist divinities and emblems are very frequently seen figured on vases like the magnificent Chien-lung one, and the eight genii or immortals are well known, although the Taoist Triad (Trinité Taoique), which includes the star gods of happiness, rank and longevity, seems less familiar, as they are so often catalogued summarily as "the wise man, the priest, and attendants."

The book concludes with an epilogue in praise of the art of porcelain and its marvelous invention; how posterity finds no fault with Cellini, who did not think he was debasing his genius or lowering the standard of art when, after having executed his celebrated Perseus, he lovingly chiselled the precious gold-work which illustrates it.

President Cleveland drinks his breakfast coffee from a cup that is worth \$20. The china set of which it is a part was made to order for the White House at a cost of \$5,000.

All the paraphernalia for the Summer drinks is beginning to appear. Flanders beer mugs have covers of silver instead of pewter and cut glass beer mugs are set in perforated silver gilt.

### The Rambler's Notes.

WHAT THE RAMBLER SAW AND HEARD AMONG THE DEALERS IN ART POTTERY, CUT GLASS, BRONZES, ETC.

DAINTY TEA SETS.

AFTERNOON tea sets, containing six dainty, finely decorated cups and saucers in a handsome case, are among the latest novelties shown by A. A. Vantine & Co., 877 Broadway, New York, which will interest jewelers. These are of Tokio porcelain in which is also shown a full line of table novelties, toilet and boudoir sets, bowls, trays, cups and saucers, tea and chocolate pots, etc. The principal decorations consist of silver ornamentation upon the inside of the piece, with cherry blossom gold upon the outside. Others, especially the large line of plates and bowls shown in many attractive shapes, have thick clusters of large white flowers on a silver ground. In conjunction with the afternoon tea sets should be mentioned a varied assortment of bronze tea pots complete with stands and alcohol lamps.

POPULARITY OF SMALL CUT GLASS ARTICLES.

THE fact that small articles in cut glass are becoming more popular than ever is well shown by the assortment of cut

glass table novelties in the bric-à-brac department of Geo. Borgfeldt & Co., 18 Washington Place, New York. Pepper holders, salt cellars, powdered sugar jars and mustard pots are among the articles seen in the greatest variety of attractive shapes and brilliant cuttings. The pepper, sugar and mustard pieces have sterling silver tops which greatly enhance the brilliancy of the cuttings. A feature of this line is the low prices at which these pieces are sold, permitting the dealer to retail them with profit at a popular price. Other dainty pieces are the white and wine colored cut crystal violet and bouquet holders of new and graceful shapes.

VASES AS SIDE ORNAMENTS.

THE F. Kroeber Clock Co., 360 Broadway, New York, have just introduced a line of vases to act as side pieces for their Porcelene clocks. In these the body is of Porcelene, and the foot, top and handles of metal, silver or gilt. There are two shapes, each of which is shown in six colors. They are made to go with any of the many styles of the clocks this company have introduced. They were manufactured to meet the demand for vases instead of candelabra as side ornaments. The latest two patterns in Porcelene one day alarm clocks, the Martha and Constance, are proving their popularity by their large and increasing sales.

# A. A. VANTINE & Co.,

877 & 879 BROADWAY,  
NEW YORK, N. Y.



200 & 202 MADISON ST.,  
CHICAGO, ILL.

**Largest Importers** JAPAN, CHINA,  
INDIA, TURKEY, PERSIA.

High Grade Porcelain, Delicate Decorations, Odd Cups and Saucers,  
Plates, Dishes, Cracker Jars, Teapots, Chocolate Pots,  
Sugars, Creams, Vases, Lamps, Jardineres.

These Goods are Made Especially for us and Meet the Demands of the Jewelry Trade.

SEND FOR SAMPLES.



# SUGGESTIONS FOR WINDOW AND STORE DECORATION.

Members of the trade who think they have an attractive window are invited to send us a photograph, or a pen and ink or pencil sketch of the same, which will be published if we consider the window contains any originality or lesson.

THE correspondent's column of the *Deutsche Uhrmacher Zeitung* contained some time ago a question as to manner by which the disagreeable sweating and freezing of a show window could be prevented. W. i. F. answers it as follows: I had in former years plenty of opportunity for observing that as regards show windows little or nothing is done to counteract the various evils to which they are prone in moist or cold weather. In many cases, these evils can be prevented at little expense; if, however, the watchmaker or jeweler owns the house in which he carries on his business, it is frequently advisable to alter the whole arrangement. By a "prac-

however, for various reasons, although the consumption of gas is very small. A partial substitute is a number of air holes, of not less than 20 millimeters in diameter each, and at least four per one meter breadth of window; these holes are to be bored in the frame close under the lower edge of the glass pane; in Summer they can be closed with cocks. When the window begins to sweat in Fall and Winter, these air vents are opened, and the entering cold air will soon establish the same temperature between the air outside and that in the show window; whereby, of course, the pane becomes clear again.

I obtained a surprisingly good effect with the arrangement shown in accompanying

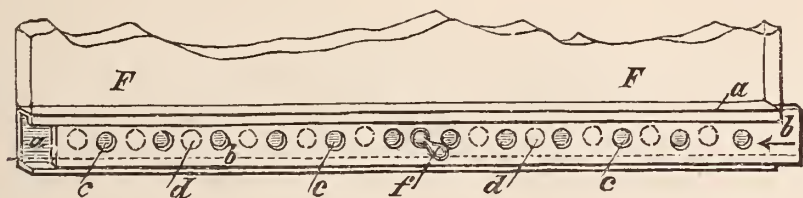

tical show window" I understand one in which 1st, the goods can be displayed to advantage; 2d, which can be cleaned easily; 3d, which allows the goods to be placed in or taken out rapidly; 4th, which must admit plenty of light, if the work bench is behind it.

The principal demand made of the show window is that the goods can be displayed in it to advantage; but this is impossible, if, for instance, it sweats or freezes in Winter. The goods exhibited in it are thereby greatly injured, especially watches, nickel plated clocks, etc., and it is therefore highly important that due steps for the prevention of these evils be taken in Summer, and, when making them, also paying great attention to having the window well ventilated. I consider the double glass sides to the interior of the store to be of little use; they do not admit the light to pass through freely, the frequent opening of the window to take out or place in goods, is rendered difficult, and but little is done to correct the original evil. If the inside window is opened for some purpose or other, the heated air of the store will enter, and a long time is required before the air is cooled again.

It is much better to locate inside at the lower edge of the window, a gas pipe with a great number of small holes, which serve as burners for just as many small flames, only a few centimeters away from the window pane. The current of air generated by the burning flames along the window pane dries the sweating window again in a short time and keeps it in this condition.

This remedy cannot be used everywhere,

sketch. I had it made in the first year of my establishment in business, after having been harrassed during the preceding Winter with a sweating or frozen show window. The pane, two meters in breadth, was taken out, and a strip of 70 millimeters cut off from the lower end. The two slides *a* and *b*, of heavy sheet iron, were next set in and sunk in the window sill about as high as shown in the dotted line, after which the window pane was placed in again. The space between the slide *a* and the pane *F* is tightened with putty.

The two slides *a* and *b* are furnished with holes of about 25 millimeters in diameter. Beside this, the slide *b* is also furnished on the outside with a knob *f*, by means of which it can be slid to and fro. In the sketch it is represented as pushed to the right, so that the holes *cc* are thereby closed by the slide *b* behind it. During the cold season the slide *b* is pushed in the direction of the arrow, therefore to the left. The holes *cc* of the slide *b* will thereby coincide with the holes *dd* of the slide *a*, and ventilation is established. The result is surprising. If the show window is opened from the inside and moisture precipitates upon it for a moment, it will become clear again at the latest in 15 minutes. So long as no heat comes into contact with the window it will not sweat.

Another remedy is to wash the frozen window with glycerine and alcohol, but it is a very disagreeable job. The just now described remedy is by far the best, but if circumstances prevent, recourse may be had to boring holes into the window frame. It is necessary that the show window is closed

from the inside with large sliding or common sashes, so that the goods can be taken out and put back quickly. If this is not the case, parties will often postpone cleaning the window as often as it should be cleaned—and this is the principal point with a good show window: it should be always as bright and clean as "elbow grease" can make it.

## Window Decoration Notes.

C. C. PAULE, Burlington, Ia., is reported to have had the finest Easter window display in that city. The background was of white satin with a draped curtain of royal purple and in each rear corner were potted Easter lilies. The centre piece was a Maltese cross of white and purple satin outlined with the smaller articles of silver and jewelry and small pieces were artistically displayed upon the satin base. The display attracted much attention.

Theo. Dilger, Pulaski, Va., sends THE CIRCULAR, a description of his Easter window which we infer must have been very attractive. Upon the flooring of the window were an anchor, heart and cross, the emblems of Faith, Hope and Charity, in the center of each of which were displayed charms and rings upon blue cotton. The outside of each emblem was trimmed with cedar. From top center of the window hung a dove holding in its mouth a star made of cotton on which were diamond brooches and scarf pins. On the base in large letters were the words Easter Greetings. In each corner were two pots of flowers and two vases of Easter lilies. At night the window was lighted by six differently colored fancy lamps. The display drew the attention of large numbers of persons. F. M. Dilger, brother of Theo., designs all the decorations for the store.

## PATENT paneled METAL CEILINGS Stamped Raised Panels.

ARTISTIC AND PERMANENT.

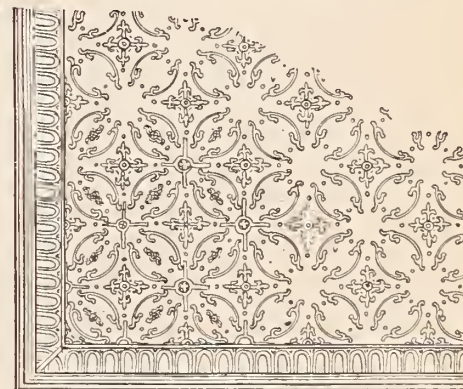

Easily applied in new buildings, and over old broken plaster or wood Ceilings. If interested in building or repairing, send stamp for Illustrated Catalogue, and state of CHURCH, HALL STORE, OFFICE, SCHOOL Ceiling is wanted. Address

A. NORTHROP & CO., Pittsburg, Pa.



↪ SILVER ↪  
**Deposit Cologne.**  
 PURE SILVER <sup>1.000</sup>/<sub>1.000</sub> FINE.



**\$3.50 EACH.**

No. 223.

**ALVIN MFG. CO.,**  
 860 BROADWAY, NEW YORK.

**Some Advertising Pays.**



Having tried *this* kind ourselves we know its value.

The cut is taken from an advertising thermometer which we got up for our own use. We are now ready to supply them to Jewelers and Opticians with their name and address at top and any desired lettering at the bottom. Size, 4 ft. long; 9 in. wide.

The glass containing spirit, is fastened to the wood back with lacquered brass clamps. The wood is nicely finished in natural color and varnished.

Railway station agents are always delighted to have them.

We have placed them in a large number of hospitals.

Those who are wide awake and all the time trying to increase their business, will send for prices.

**QUEEN & CO.,**

OPTICIANS,

1010 CHESTNUT ST., PHILADELPHIA.

**The Other Side of Life.**

**CITY MISSIONARY**—Why do you always refer to your absent father as "the clock?"  
**MISSION YOUNGSTER**—'Cause he's doin' time.—*Philadelphia Record.*

A little Tioga girl, whose papa was taking a tonic because he was "run down," poured half the contents of the bottle into the clock when a similar mishap befell the timepiece.—*Philadelphia Record.*

**TOM** (as he blows out a ring of smoke)—Ah, isn't that a perfect ring?

**GRACE** (with feeling, as she puts her finger through it)—Oh, Tom! how nice it would be if it were only gold.—*Tid-Bits.*

"Isn't it strange that Miss Flirt, who is such a belle, has never been engaged?"

"Yes; she's a sort of bell without a ring."—*Philadelphia Record.*

**COMPLIANCE.**

"Speak!" She heard him plead, yet hesitated. "Speak!" he persisted. She bestowed upon him a quick, searching glance. "Speak, I pray you!"

"Very well." Clearing her throat, she recited with great fire, "Curfew Shall Not Ring To-night."—*Detroit Tribune.*

**AS THE CLOCK STRUCK TWELVE.**

**HE**—It is endurance, the staying quality, that makes men strong.

**SHE** (with a glance at the clock)—You must be a Hercules.—*Harper's Bazar.*

**ABSENT-MINDED BUSINESS MAN** (to office boy)—"William, go up to my house and tell Mrs. Briggs I have again forgotten my watch. Bring it back with you." He pulls out his watch and continues: "Now, William, it is nine o'clock; be back at ten."—*Tid-Bits.*

"See here," remarked the counsel for the defense to the important witness. "I'll give you a \$20 gold piece if you leave town."

"Done!" replied the important witness; "I always did believe that silence was golden."—*Philadelphia Record.*

Every woman agrees that the cumbersome manicure boxes are a nuisance except to ornament a dressing table. Many empty their cases, dump the tools on a long sachet, and roll them up in a bundle to put in their trunk when traveling. An improved arrangement has been seen in which a slab about as long as an octavo book was covered with chamois skin. On this were the implements held in place by leather straps.

**REMOVAL TO 45 MAIDEN LANE, N. Y.**      **REMOVAL TO 45 MAIDEN LANE, N. Y.**      **REMOVAL TO 45 MAIDEN LANE, N. Y.**

**Leon Hirsch, IMPORTER OF Watches.**

**REMOVAL.**

**WE DESIRE TO NOTIFY OUR CUSTOMERS AND THE TRADE IN GENERAL, THAT AFTER MAY 1st, WE WILL BE LOCATED AT**

**860 BROADWAY, NEW YORK, North East Cor. 17th St. and Broadway.**

**T. B. CLARK & CO.,**  
 (INCORPORATED.)

**N. B.** We call special attention to our new JEWEL pattern in medium price and our CARNATION in rich cut glass ware.



# HINRICHS & CO., 29 AND 31 PARK PLACE, NEW YORK. BRIC-A-BRAC AND ART POTTERY.

## THE CHARMILLES WATCH



is a new departure in watchmaking. It is the invention of Albert H. Potter, one of the most celebrated and scientific watchmakers living, and is protected by numerous patents the world over. The movement and case are one and the same, thus permitting a *higher quality movement* at the expense of the case—producing a *finely finished solid nickel movement* cased in the least expensive and simplest form, giving a *better value for the money* than higher priced watches.

The stem winding and pendant hand setting mechanism is simple, durable and *positive in action* and is a feature of the watch.

It consists simply of two upright wheels set in a solid block, one engaging in an intermediate winding wheel, the other in an intermediate face wheel. Pulling the stem out engages the hand setting wheel, pushing it in engages the winding—each operation is *positive*—no jumping of hands.

This device is to be found *exclusively* in the "Charmilles" watch and only needs to be seen to be appreciated.

Because the *price is low* "Charmilles" watches must not be classed with the many inferior watches with which the market is flooded and the Jeweler's reputation jeopardized.

"Charmilles" watches are suited to the times—the *greatest value for the least money*.

Illustrated Price List with full descriptions and prices mailed upon application to any leading Jobber.

## The Latest Triumph.

### THEODORE C. STEINHAUS,

— MANUFACTURER OF —

## Fine Cases and Trays

For JEWELRY, SILVERWARE, &c.

SAMPLE CASES AND TRAYS FOR TRAVELERS.

Fancy Hard Wood Chests for Silverware, &c.

Linings, Cushions, Mounting, etc., for Silver Novelties.

10 MAIDEN LANE, NEW YORK.

## EMPIRE GOLD and SILVER PLATING WORKS.

### FRITZ MORRIS, GOLD • AND • SILVER • PLATING

— IN ALL THEIR BRANCHES. —

Case Repairing, Polishing, Etc., Dial Painting, Coloring, Gilding, Etc.  
75 and 77 NASSAU STREET, NEW YORK.

It is economy to save a penny when you can. You will save many pennies by sending anything in the plating line to my factory, where it can be renovated, replated, recolored or repaired satisfactorily, and at a price beyond competition. I make a specialty of jewelry, romanizing and satin finishing, and of family table ware. Others speak of their good work, my work speaks for itself. Out of town trade solicited and estimates cheerfully given.

FRITZ MORRIS.

## "THE BEST BUTTON MADE."

### THE KREMENTZ

IN GOLD

IN ROLLED PLATE

FROM

KREMENTZ & CO.

ONE PIECE

FROM

AND ALL JOBBERS.



ALL JOBBERS

## COLLAR\* BUTTON.

IS THE ORIGINAL ONE PIECE BUTTON.

IS STILL THE BEST AND STILL UNSURPASSED.

Sold by all wholesale dealers at manufacturer's price.

A. N. CLARK, PLAINVILLE, CONN.

Manufacturer of the Celebrated LOOP WATCH KEY.

The Best for the Price in the World. CROSBY'S JEWELING TOOLS IMPROVED.

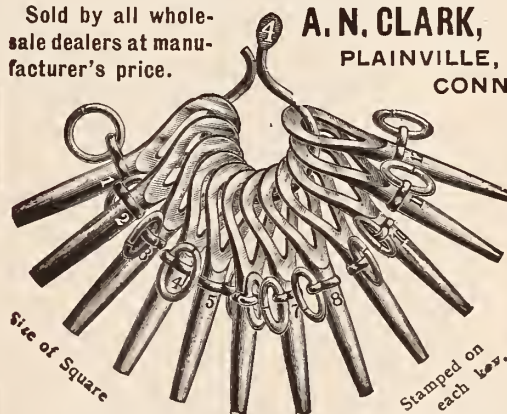

Size of Square

Stamped on each key.

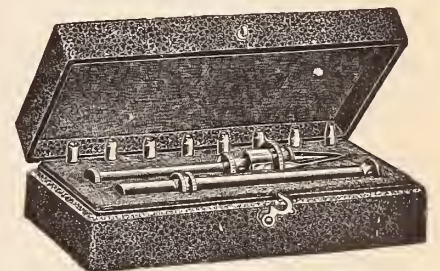

Will quote royalty or price for the manufacturing of articles of real worth.

# REMOVAL S. Valfer & Co., REMOVAL

TO MANUFACTURERS OF JEWELRY AND SILVERWARE CASES, TO S. F. MYERS BUILDING, Nos. 48 & 50 MAIDEN LANE, NEW YORK.





**B. & W. B. SMITH,**

220 W. 29<sup>TH</sup> ST.,  
NEW YORK.

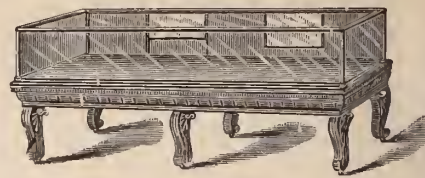

IMPROVED DUST TIGHT.

Dust Tight Wall Cases. Improved system of Shelving and Electric Wall and Counter Cases Lighting.

◁ SMALL CASES FOR SPECIALTIES. ▷

ALL GLASS.

NO MOULDINGS

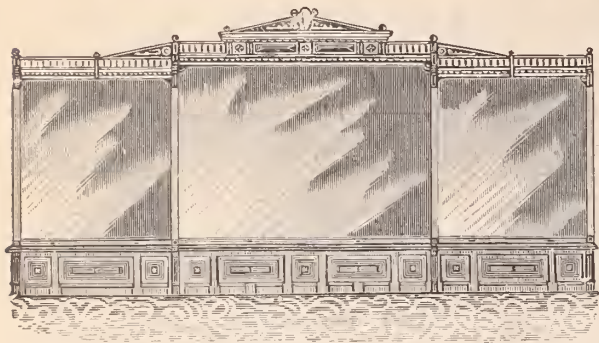

1869-1894=Twenty-five Years Oldest, Best Brightest, Newest=The Jewelers' Circular.

**S. F. MYERS & CO.,**

WHOLESALE JEWELERS,  
MYERS BUILDINGS, - - NEW YORK.

1894 ISSUE, No. 38,

**OUR ROYAL CATALOGUE**

Illustrates all that is new, unique and desirable in everything that pertains to jewelry.  
Sent free to dealers who have not received it.

TWENTY-TWO DEPARTMENTS.  
SEVEN DOUBLE FLOORS.

Myers Buildings, 48-50 Maiden Lane, New York,  
33-35 Liberty St.,

FRENCH ENGLISH  
CLOCKS AND HALL CLOCKS AND  
MATERIALS. MATERIALS.

**CHAS. JACQUES CLOCK CO.,** 22 CORTLANDT ST., N. Y.

**J. SCHAWEL & CO.,** 29 John St., N. Y.

GOLD & SILVER REFINERS, ASSAYERS & SWEEP SMELTERS.  
STERLING SILVER, 995/1000 FINE IN SHEET AND WIRE.  
Soft Platinum, Sheet and Wire for Manufacturing Jewelers.

**J. PRINCE,**  
Jewelry Auctioneer,  
At liberty from January 1st, 1894. Retail  
Jewelers only. Address,  
Rooms 9 & 10, 137 BROADWAY  
N. Y. CITY.

**WM. BIRMINGHAM & CO.,**  
MANUFACTURERS OF  
All Kinds of Leather Spectacle and Eye Glass  
**CASES,**  
728 Arch Street, PHILADELPHIA, PA.

For **BADGES AND MEDALS**

Flag Pins, Glass Pins, Glass Rings  
and Special Work of all Descriptions  
SEND TO **E. R. STOCKWELL, MANUF'R.**  
19 John Street, New York

**NEW CLOCK STAFF WRENCH.**



This entirely new and most useful tool is for setting up clocks, particularly fine and costly ones. Can remove pivots at ease. No chance of displacing other pivots in the operation. For description, send 5c. in stamps for catalogue of over one thousand varieties of fine tools.

O. W. BULLOCK & CO., Springfield, Mass.

**OPPENHEIMER BROS. & VEITH,**  
WATCHES AND



**DUEBER CASES, HAMPDEN MOVEMENTS.**  
AMSTERDAM, HOLLAND, 2 TULPSTRAAT. LONDON, ENG., 28 HOLBORN VIADUCT.  
NEW YORK, 35 MAIDEN LANE.

If Your Sales  
Are Not Satisfactory

ADDRESS

**DE B. O. SCOTT,**

20 Murray Street, New York.  
AUCTIONEER.

Specialties: Watches, Clocks, Bric-a-Brad, &c.

Write for particulars and references.

**TOWLE**

MANUFACTURING  
COMPANY.

OLD ENGLISH STRAWBERRY FORK.  
**STERLING SILVER**  
TABLE WARE,  
IN A COMPLETE ASSORTMENT.

149-151 STATE STREET,  
CHICAGO, ILL.

Newburyport, Mass.



**IT PAYS** TO KEEP IN TOUCH WITH TRADE AFFAIRS. For 4c. a Week will do it. **Subscribe.**



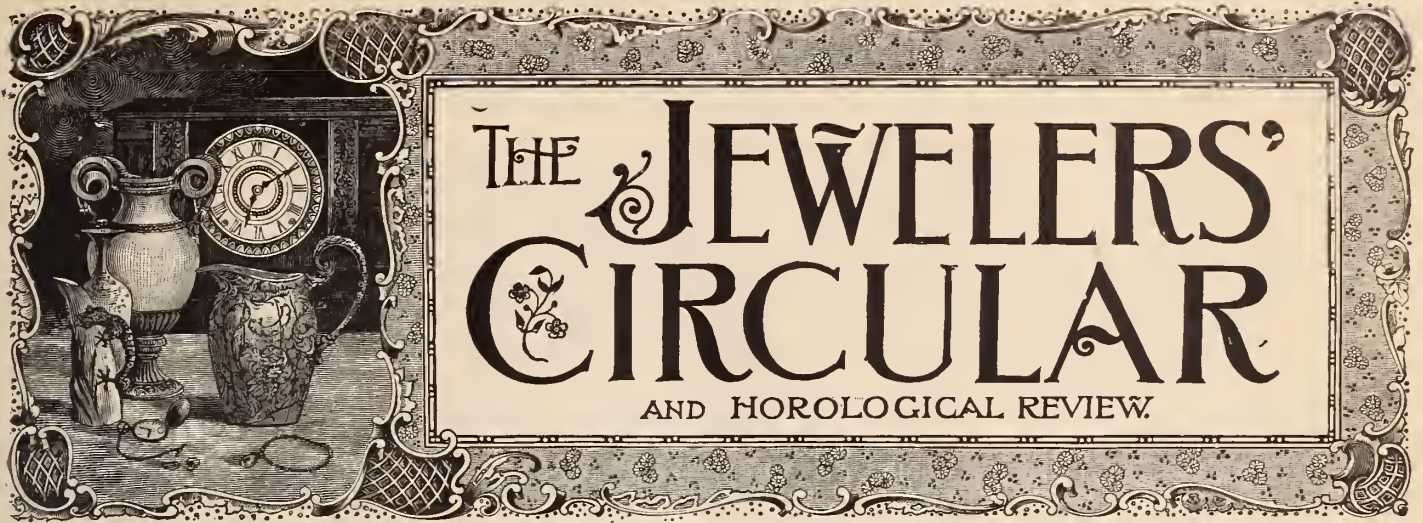

Copyright by THE JEWELERS' CIRCULAR PUB. CO.

189 Broadway, New York.

Entered at the Post Office in N. Y. as second-class matter.

VOL. XXVIII.

NEW YORK, WEDNESDAY, MAY 2, 1894.

No. 13.

MUSIC AND SILVER IN POETIC COMBINATION.

FRANCIS DE KORBAY, the distinguished Hungarian artist who has done so much to cultivate musical taste in America and who, after a residence here of over 20 years, is about to leave New York, was a few days ago presented by a group of his friends with a beautiful testimonial, as an expression of appreciation and of regret at his departure. The presentation took place at the house of Judge and Mrs. Henry E. Howland. Judge Howland made the address and presented the testimonial, which was in the form of an artistic silver loving cup made by Tiffany & Co.

Paulding Farnham, who designed the cup, threw into the work his own artistic feeling, making the sympathetic metal respond to his touch and express the melody and song of the Hungarian artist. It was the "singing reeds" in his Hungarian home which first inspired Francis de Korbay to sing in his early youth and later to give to the musical world the favorite "Reed Songs." These are symbolized in a growth of reeds, springing from the base and twining into two graceful handles, which delicately suggest a heart. On one side of the body of the cup, chased in relief, is pictured a Hungarian nobleman, mounted on a handsome horse and clasping a harp, and in the background are seen the hills of Buda Pest, the

whole symbolizing the universal patronage that the art of music receives throughout fully etched, and reading :

FRANCIS KORBAY,  
E DONO AMICORUM,  
Pimplei Dulcis Hunc Fidibu  
Hovis Hunc Lesbio Sacrare  
Plectro Tecque Tuasque  
Decet Sorores,

which translated reads:

"Given by friends. Fair Muse,  
"to render this man immortal  
"with fresh strains and by the  
"Lesbian lyre becometh both thee  
"and thy sisters."—*Horace*, Book  
I, Ode xxvi.

Beneath the body of the cup and rising from the base are two cast figures, standing about 5 inches high, and these, too, are characteristic of the honored artist. One is an idealistic figure representing the declaiming of melody and song; the other represents the transcribing of poetry or prose. The cup weighs about eighty ounces and stands 13½ inches high.



THE SILVER TESTIMONIAL TO F. DE KORBAY, THE HUNGARIAN MUSICIAN.

Hungary. On the opposite side is introduced a Latin motto, the inscription, beauti-

of the late Comte Paul, who was one of the court chamberlains of Napoleon.

of the late Comte Paul, who was one of the court chamberlains of Napoleon.

Relics of Napole on.

AS there is at the present time a strong Napoleonic revival, not only in France but also throughout Europe and America, mementos of the Napoleonic period will doubtless attract general interest. A fortnight ago an historically notable collection was brought from France to the United States. The collection saw its origin with Comte Roget de Molenes, father



# DEITSCH BROS.,

7 EAST 17TH ST., NEW YORK.

## LEATHER GOODS.

EBONY AND SILVER COMBINATIONS.

ORIGINATORS AND MAKERS OF

NOVELTIES IN LEATHER AND STERLING SILVER COMBINATIONS.



# CROSS & BEGUELIN, 17 MAIDEN LANE, NEW YORK,



960 GOLD PIN. \$15.60 doz.



944 GOLD PIN. \$12.00 doz.



986 Gold Lapel Button. \$8.40 doz.

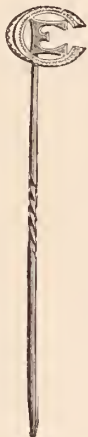

1117 SCARF PIN. Gold, \$5.60 doz. Silver, 2.80 doz.



341 GOLD CHARM. \$43.20 doz.



421 CHARM. Gold, \$15.60 doz. Silver, 7.80 doz.



1131 PIN. Gold, \$8.40 doz. Silver, 4.20 doz.



1018 PIN. Gold, \$7.60 doz. Silver, 3.80 doz.



1130 Enameled Pin. Gold, \$9.60 doz. Silver, 4.80 doz.



950 GOLD PIN. \$15.60 doz.



803 GOLD PIN. \$10.80 doz.



1081 LAPEL BUTTON. Gold, \$12.00 doz. Silver, 6.00 doz.

HEADQUARTERS FOR Emblems, Gold, Silver and Plate.

Write for Illustrated Catalogue.

# AMERICAN SYNDICATE OF Jewelers' Auctioneers.

ESTABLISHED for the sole purpose of conducting sales for established Jewelers in the United States, Canada and Mexico. We do not sacrifice your goods. We take no sales on a percentage. Our terms are strictly one-half the profits realized on all goods sold. We guarantee you against any loss. We pay all our own expenses; we don't ask you to pay one cent of expense on our account. We buy stocks complete as well as sell them. If your stock is small, or your assortment is not complete, we will furnish from one to ten thousand dollars worth of any kind of stock you may need and in which you need not invest one penny. Don't make any arrangements with others until you read our pamphlet which we will send you free, giving you full particulars of our style of doing business, and the liberal offers we make to Jewelers. We don't care how small your stock is, we will furnish all the stock you need to make a successful sale. We challenge the world for any fairer or more liberal propositions than we make Jewelers. Don't fail to send us your address, and we will send you our business pamphlet, which gives you full explanations as to our terms and style of doing business. Address,

## AMERICAN SYNDICATE OF JEWELERS' AUCTIONEERS.

Offices: 20 WEST 14th STREET, NEW YORK. 611 PENN AVE., WASHINGTON, D. C.

## CAMPBELL-METCALF SILVER CO.



2 Maiden Lane, N. Y., with Holmes & Edwards Silver Co. 66 Stewart St., Prov., R. I. Mills Bldg, San Francisco, 8th Floor, Room 1.

# "THE BEST BUTTON MADE."

THE KREMENTZ

IN GOLD

IN ROLLED PLATE

FROM

KREMENTZ & CO.

ONE PIECE

FROM

AND ALL JOBBERS.

ALL JOBBERS\*



### COLLAR BUTTON.

IS THE ORIGINAL ONE PIECE BUTTON.

IS STILL THE BEST AND STILL UNSURPASSED.

JACOT & SON IMPORTERS AND MANUFACTURERS OF MUSICAL BOXES 39 Union Sq., New York.



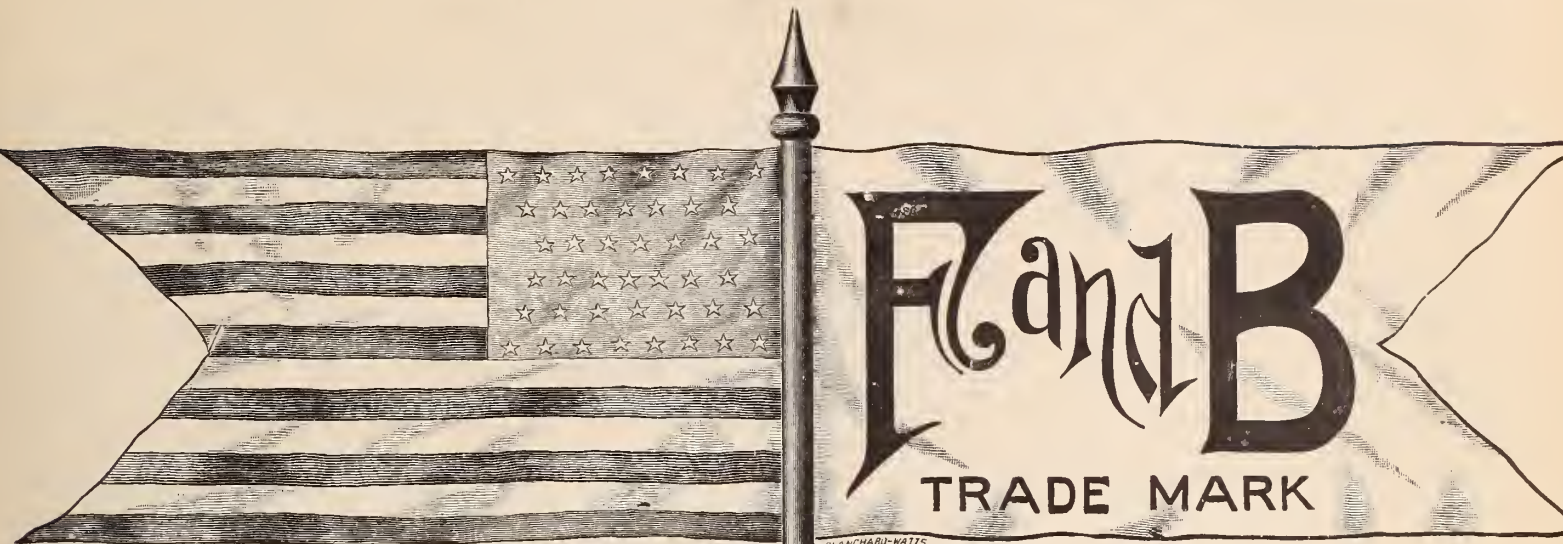

No. 1. Match Box and Cigar Cutter Combined.



No. 2. Match Box and Cigar Cutter Combined.

**Chains**  
Our new line of chains will assay 10 karat 1-10 gold. All gold soldered.  
**American F. & B.**  
1-10 gold.

**Watch Chains for Gentlemen**  
These goods are of fine quality, and guaranteed to give satisfaction. Some recently added have sold far beyond expectation. They are made of heavy rolled plate in all sizes and patterns.

**Watch Chains for Ladies**  
Our Victoria and Princess chains are neat and pretty. They are made in all bright, Roman and bright, platinum and bright gold, and have one or two charms.

**Charms**  
This line is adapted to ladies' or gentlemen's chains, and includes a number of heart charms in Roman, bright and satin finish, with stones and without.

**Hair Chain Mountings**  
In solid gold and rolled plate. We are headquarters and make everything desirable in this line.

**Bracelets**  
We make a large stock of curb bracelets in five sizes, besides the graduated links, with padlocks and snaps, in chased and plain polished, Roman, rolled silver plate and sterling silver. Also padlocks with keys and a push snap.

**Pins**  
Our large line of lace and cuff pins comprise many desirable patterns in gold fronts engraved and trimmed. Also includes baby pins and scarf pins.

**"Mt. Hope" Buttons**  
These are superior to any button in the world. They are easy to put in and easy to take out of the cuff.

**Link Buttons**  
This line has increased rapidly with us, and is very low in price, embracing all styles in Roman, chased, engraved and plain, with and without stones, and some in enamel.

**Crosses**  
We make four sizes of gold filled in plain, engraved and set with stones, and suitable for our neck chains.

**Sterling Silver and Solid Gold Sword Scarf Pins**

**Glove Buttoners**  
We make the interlocking and one with a twist handle in gold rolled plate and silver rolled plate.

**Earrings**  
This line includes many pretty patterns in gold fronts engraved, some with pretty trimmings and a small line of loop drops.

**Neck Chains**  
We make a variety of neck-chains in bright and Roman, with snaps.

**Sterling Silver Bracelets and Padlocks**

**Gold Locket Set with Diamonds**  
These lockets are made of 10 karat gold throughout and set with brilliant diamonds. They cannot be surpassed in finish or cheapness of price.

**Gold Locket Engraved**  
These lockets are also made of 10 karat gold throughout, with beautiful designs engraved thereon and the price is so low that they cannot fail to be in great demand.

**Gold Front Locket**  
This line is very extensive. Many patterns are plain polished, others nicely engraved, with and without stones.

**Roller-Plate Locket**  
This line is almost endless, and consists of nearly every conceivable shape, size and style. Some are set with imitation diamonds, rubies and sapphires.

We have put upon the market a line of Gentlemen's Chains and Ladies' Chain Bracelets made of 1-10 gold stock. Every joint is soldered with gold, and every Chain or Bracelet will assay more than 1-10 gold. They are our AMERICAN F. & B. 1-10 GOLD goods, and are so stamped. Bar, Chain and Swivel are stamped 1-10 gold.

**FOSTER & BAILEY,** 100 RICHMOND ST., PROVIDENCE, R. I.



After the death of Napoleon his devotion to the institutions of the First Empire led him to collect not only relics of the Empire, but also the finest specimens of artistic objects of that period, which are so distinct from those of any other period. He also devoted his efforts to gathering a representative collection of large miniatures on ivory, painted by the artists of the time of Louis XV. and Louis XVI., as well as miniatures by Gerard, David, Moreau, Le Metayer and other well-known miniaturists of the Napoleonic court. These miniatures represent court beauties of Versailles, among them Gabrielle de Lorraine, Louise de Bourbon, Mme. du Chatelet, Mme. de Parabere, Diane de Poitiers, la Princesse de Conde, Marie Antoinette and la Princesse de Lamballe. A miniature of Josephine by Gérard is one of the gems of the collection.

There is a table centerpiece in gold which comes from Malmaison, and was used at receptions given by Josephine. This centerpiece is round, exquisitely chased on all sides and is said to be one of the most remarkable specimen of the goldsmith's art of that period in existence. A triple branched candelabrum, said to have been used on the

Emperor's writing desk at St. Cloud, is also in the collection. The circular shade, bearing the initial and crown of Napoleon is new, but is an exact reproduction of the original one, which was destroyed a number of years ago.

There is an excellently interesting collection of statues of Napoleon, over 50 in number. One of them, by Riviere, is admirably executed, as is also one by Levachez, which represents Napoleon on horseback. Several of the numerous clocks in the collection are of special historical interest. Among them is one bearing a group, representing Napoleon at Ulm, the base being supported by cannon and trophies.

The collection contains a number of gold chiselled vases which belonged to various of the marshals of Napoleon. There are two enormous vases, in blue Sèvres, with paintings of Napoleon, which are said to be unique and almost of priceless value. There is also a quantity of quaint furniture and odd bric-à-brac of the First Empire.

H. R. German, formerly employed by J. F. Beyerle, Reading, Pa., has opened a store at 805 Franklin Street, that city.

#### The Death of Lock Haven's Oldest Jeweler.

LOCK HAVEN, Pa., April 25.—Voley Isbel died at 2 o'clock Tuesday morning at his home near Woolrich after an illness of two weeks. Mr. Isbel was 70 years old the 11th of last February, and was the oldest jeweler in Lock Haven, where he did business until his store was burned out several years ago.

Of recent years he had been assisting at the stores of G. M. Keller, Mrs. F. Goldstein and the Keystone Jewelry Co., and was at work at the latter store two weeks ago last Saturday.

#### Jeweler Crane Takes Back His Printing Plant.

SAVANNAH, Ga., April 24.—E. J. Crane, the colored jeweler at 168 Broughton St., has closed up the office of the *Labor Union Recorder*, one of the weekly organs of the colored people published in this city. The jeweler, it appears, owns the plant which has been used by W. J. Lewis in publishing the paper, and the former, apprehending trouble between Lewis and his employes, withdrew the loan of the plant.

# JOHN R. KEIM, MANUFACTURER OF FINE DIAMOND JEWELRY, 21 East 17th Street, New York.

SOLE AUTHORIZED MANUFACTURER OF THE PALMER COX "BROWNIE" JEWELRY, AND ALL ARTICLES IN ENAMEL OR METAL; BY PURCHASE FOR THE PURPOSE FROM PALMER COX, ESQ., OF HIS COPYRIGHTS, PATENTS, PATENT RIGHTS AND ORIGINAL "BROWNIE" DESIGNS.



## THE QUESTION ?

WILL IT TARNISH ? Need

not be asked if your Tissue Paper bears this label.

MANUFACTURED BY

# C. H. Dexter & Sons,

WINDSOR LOCKS, CONN.

◁ BE SURE YOU GET THIS BRAND. ▷

It has been adopted and is now used by the leading manufacturers of this country.



THE  
*Pairpoint*  
 Makers and Designers of  
 "Superior" Gold  
 AND  
 Silver Plate



No 934. RING STAND, PIN CUSHION AND TRINKET TRAY COMBINED.

MFG. COMPANY, New Bedford, Mass.

FACTORIES:

Rich Cut Glass

AND FINE

Decorated Art Wares.

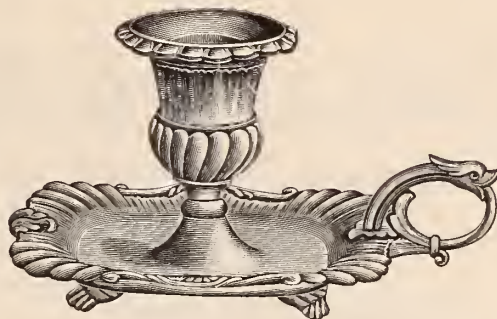

No. 6105 CANDLESTICK.

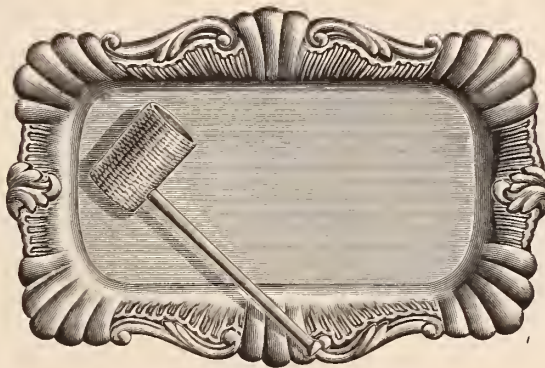

No 1962: ASH RECEIVER.

THE BEST selling goods on the market bear the stamp of.....

PAIRPOINT.



No. 3744. TOOTH PICK HOLDER.

A. J. LOGAN,

MANUFACTURER OF  
 WATCH TOOLS, HAIR SPRINGS AND  
 WATCH MATERIALS.

◀ New Catalogue just issued, Sent on Application. ▶  
 WALTHAM. MASS.

CROUCH & FITZGERALD.

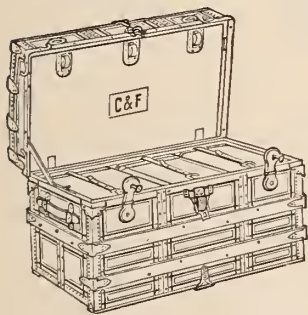

Jewelry Trunks  
 and Cases.  
 161

Broadway,  
 Bet. Cortlandt and  
 Liberty Sts.,  
 688 B'way,  
 701 6th Ave.,  
 NEW YORK.

PATENTS SECURED WITHOUT  
 FAIL OR DELAY.

Send Rough Sketch or Model and I will tell you whether you can obtain a patent, WITHOUT CHARGE.

Fifteen years' experience. Ample references. Address  
**C. T. BELT,**  
 WARDER BUILDING WASHINGTON D. C.

2 MEDALS AWARDED



AT  
 WORLD'S  
 FAIR,  
 1893.

Providence Shell Works, Providence, R. I.  
 Correspondence Invited.

We sell to the legitimate Jewelry and Stationery trade only.



CHOICE PAPERS

MAKERS OF

FINE STATIONERY

For Correspondence, Wedding and Business Use, handsomely boxed, specially suited to the Jewelry Trade.

18 MURRAY STREET, NEW YORK.



# R. WALLACE & SONS MFG. CO.

SILVERSMITHS

Trade Mark.

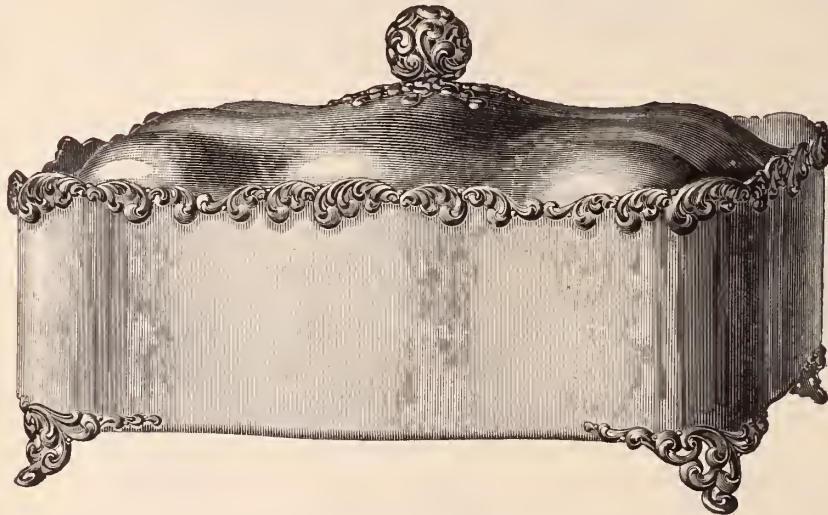

WAVERLEY SARDINE BOX.

Manufactories and  
Main Office,

WALLINGFORD, - - CONN.

BRANCHES :

NEW YORK  
3 PARK PLACE.

SAN FRANCISCO,  
120 SUTTER STREET.

CHICAGO  
86 WABASH AVENUE.



**Proceedings of the Manufacturing Jewelers' Board of Trade.**

PROVIDENCE, R. I., April 25.—The regular monthly meeting of the directors of the Manufacturing Jewelers' Board of Trade was largely attended and was called to order by President Wilcox. Notice was given that a settlement had been effected with the assignee of Strauss & Stern, Cincinnati, O., on a basis of 17 cents on the dollar. Concerning this case Secretary Morton in his last annual report to the Board made the following statement: "Strauss & Stern assigned and submitted an offer in compromise of 25 per cent., based upon condition that all creditors accept. The condition defeated the carrying out of the settlement and we are informed the offer has been withdrawn; 55 creditors, \$25,237.57."

Since the annual session the first of the year, great efforts have been put forth for the purpose of increasing the membership with such satisfactory results that at this meeting 15 new concerns were added to the list of members.

**Terrific Explosion in a Jewelry Store.**

LOS ANGELES, Cal., April 20.—An explosion occurred at five minutes after midnight Monday night, which remains a mystery. There was a report like the firing of a 20-inch cannon, a blaze shot up in the sky and the buildings 455, 457 and 459 S. Spring St. were in an instant almost obliterated.

A hurried investigation showed that Nos. 455, 457 and 459 were completely destroyed, while Nos. 453 and 461 were badly injured, doors and windows being torn out by the terrific concussion. The explosion evidently occurred near the north side of the room of Ben Babarowski's jewelry store, near the safe, in the center of the building. Here it was that the floor joists were torn and twisted into splinters, as though dynamite or giant powder had exploded. The large, heavy safe was turned on its side and covered with debris. As no one has been able to reach it, there is no telling whether it is blown open or not. The whole interior is simply a mass of ruins, with the heavy tin roof covering the whole.

Some think that the explosion might have been caused by a can of gasoline, others by an engine used in the jewelry store, but the most plausible theory is that either dynamite or nitro-glycerine was used.

**The Assignment of J. J. Dunlap & Co. Declared Void.**

BRIDGEPORT, Conn., April 26.—A hearing was held in the probate court yesterday afternoon on the insolvent estate of J. J. Dunlap & Co., jewelers. The individual assignment of J. J. Dunlap was accepted but the assignment of J. J. Dunlap & Co. was declared null and void.

Judge Tallmadge so ruled as Henry M. Hill, Winchester, N. H., Mr. Dunlap's partner who had not signed the insolvency proceeding, protested, declaring the firm was solvent.

**THE BOWDEN SEAMLESS RING**

IS MADE ONLY BY

**J. B. BOWDEN & Co.,**

Makers of Finger Rings of every Description.

REMOVED FROM BROADWAY AND JOHN STREET,

**TO 3 MAIDEN LANE,**

NEW YORK.



**W. H. SCHWARTZ & Co.**  
 MANUFACTURERS OF FINE  
**JEWELRY**  
 AND  
 NOVELTIES  
 IN GOLD AND SILVER.  
 355 Mulberry Street.  
 Newark, N. J.

**J. R. WOOD & SONS,  
 14 JOHN STREET, NEW YORK.**



PLAIN SOLID GOLD RINGS.  
 SEAMLESS PLAIN SOLID GOLD RINGS.  
 ENGRAVED AND CHILD'S RINGS.

No Ring Stamped Different from Quality.  
 Send for Catalogue and Price List.

Old Gold and Silver received and estimated on: If amount allowed does not give satisfaction, notify at once and will return at our expense, in same condition as received.

**ENTIRELY NEW AND  
 EXCLUSIVE LINES**

OF HIGH GRADE

**Sterling Silver Novelties.**



**Bachrach & Freedman,**

Nos. 1 & 3 Union Square,

NEW YORK.



SPECIALTY: SALES OF  
**JEWELRY, BRIC-À-BRAC**  
 AND  
 ARTICLES OF VERTU

**Prices of LATHES and CHUCKS are "WAY DOWN"**

All purchasers of our THREE FOUR lathes and chuck combinations now receive FREE our new TIP OVER "T" REST, on which we have patent pending. The most valuable addition to plain lathes in recent years.

SEND FOR FEB. PRICE LIST.

WALTHAM WATCH TOOL CO., SPRINGFIELD MASS

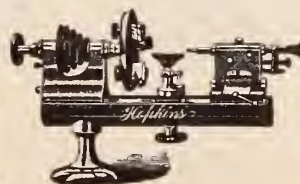



NOW ON THE MARKET.

# VANGUARD.

18 SIZE FULL PLATE.

HUNTING OR OPEN-FACE. OPEN-FACE ARE PENDANT SETTING.

The Latest <sup>AND</sup> Greatest Achievement  
in Watchmaking.

Made both Regular and Non-Magnetic.



**NICKEL;** 17 Extra Fine Ruby Jewels in Raised Gold Settings; Double Roller; Exposed Pallets; Embossed Gold Patent Micrometric Regulator; Compensation-Balance in Recess; Adjusted to Temperature, Isochronism and Position; Patent Safety Barrel; Exposed Winding Wheels; Patent Breguet Hairspring, Hardened and Tempered in Form; Elaborately Finished Nickel Plates with Gold Lettering; Plate and Jewel Screws Gilded; Steel Parts Chamfered; Double Sunk Dial. The Vanguard is the Finest 18 Size Movement in the world.

Manufactured and Warranted by the

# American Waltham Watch Co.,

OF WALTHAM, MASS.



**The New York Silver Bill Passed by Both Houses.**

ALBANY, N. Y., April 24.—Senator McMahon's bill, amending the Penal Code by making it a misdemeanor to sell or to offer for sale merchandise falsely stamped "sterling" or "coin" silver, was passed by the Assembly to-day.

The bill as passed is as follows:

SECTION 1. A person who makes, or sells, or offers to sell or dispose of, or has in his possession with intent to sell or dispose of, any article of merchandise marked, stamped, or branded with the words "Sterling," or "Sterling Silver," or incased, or inclosed in any box, package, cover or wrapper, or other thing in, by or which the said article is packed, inclosed or otherwise prepared for sale or disposition, having thereupon any engraving or printed label, stamp, imprint, mark, or trade mark, indicating or denoting by such marking, stamping branding, engraving or printing that such article is silver, sterling silver or solid silver unless  $\frac{3}{1000}$  of the component parts of the metal of which the said article is manufactured is pure silver, is guilty of a misdemeanor.

SEC. 2. A person who makes or sells, or offers to sell or dispose of, or has in his possession with intent to sell or dispose of, any article of merchandise marked, stamped or branded with the words "Coin," or "Coin Silver," or encased or inclosed in any box, package, cover or wrapper, or other thing in, by which the said article is packed, inclosed or otherwise prepared for sale or disposition, having thereupon any engraving or printed label, stamp, imprint, mark, or trade mark, indicating or denoting by such marking, stamping, branding, engraving or printing that such article is coin or coin silver, unless  $\frac{3}{1000}$  part of the component parts of the metal of which the said article is manufactured is pure silver, is guilty of a misdemeanor.

SEC. 3. This act shall take effect upon its passage.

The bill was passed some time ago by the Senate, and now only awaits the Governor's signature.

**The Massachusetts Silver Bill as Approved by the Governor.**

BOSTON, Mass., April 26.—The bill to regulate the manufacture of silverware in Massachusetts, approved by Gov. Greenhalge early in the present week, will be known as Chapter 292, of the Acts and Resolves of 1894, and reads as follows:

AN ACT TO REGULATE THE SALE

OF GOODS MARKED "STERLING," "STERLING SILVER," "COIN," OR "COIN SILVER."

SECTION 1. A person who makes or sells, or offers to sell or dispose of, or has in his possession with intent to sell or dispose of, any article of merchandise marked, stamped or branded with the words "sterling," or "sterling silver," or encased or inclosed in any box, package, cover or wrapper or other thing in or by which the said article is packed, inclosed or otherwise prepared for sale or disposition, having thereon any engraving or printed label, stamp, imprint, mark or trade-mark, indicating or denoting by such marking, stamping, branding, engraving or printing, that such article is silver, sterling silver, or solid silver, unless nine hundred and twenty-five one-thousandths of the component parts of the metal of which the said article is manufactured are pure silver, shall be deemed guilty of a misdemeanor.

SECT. 2. A person who makes or sells, or offers to sell or dispose of, or has in his possession with intent to sell or dispose of, any article of merchandise marked, stamped or branded with the words "coin," or "coin silver," or encased or enclosed in any box, package, cover or wrapper or other thing in or by which the said article is packed, inclosed or otherwise prepared for sale or disposition, having thereon any engraving or printed label, stamp, imprint, mark, or trade-mark, indicating or denoting by such marking, stamping, branding, engraving or printing, that such article is coin or coin silver, unless nine hundred one-thousandths of the component parts of the metal of which the said article is manufactured are pure silver, shall be deemed guilty of a misdemeanor.

SECT. 3. Whoever violates the provisions of either of the preceding sections shall forfeit a sum not exceeding one hundred dollars for each offence.

SECT. 4. This act shall take effect upon its passage.

**A Big Clock Factory for the Village of Harrison, O.**

CINCINNATI, O., April 30.—It is reported that the deal between the Heck Clock Mfg. Co., of Hartford, Conn., and the people of Harrison was consummated Tuesday last. The deal is to build a big plant in Harrison and move the Heck factory there. Some days ago Manager Shellberger, of the clock company, went to Harrison, and Tuesday the papers were drawn up and signed. The company agree to employ 200 men the first year, and if business prospers

they promise to employ 1,000 hands in three years.

The company agreed to begin erecting the buildings in 30 days, at which time they will deposit, as a sign of good faith, \$50,000 in a Harrison bank. The company have laid out 200 building lots of 50 by 200 feet each, which will be taken by the people of Harrison and dwelling houses will be erected for the employes of the concern. There will be a celebration the day ground is broken for the work.

**The Death of Richard L. F. Everett.**

Richard Louis Ferdinand Everett, a well known retired jeweler, died at his residence, 102 W. 92d St., New York, Monday, April 23d, from cerebral apoplexy.

Mr. Everett was born in Providence, R. I., in 1834, and went to New York when a young man. He was actively connected with the jewelry trade for over 30 years. After representing E. Ira Richards & Co. on the road for a number of years, he left that concern to form a partnership with Bliss Bros., under the firm name of Bliss Bros. & Everett, with a factory in Attleboro, Mass., and a New York office at 176 Broadway. Here he remained until the firm dissolved in 1888, when he retired from active business life.

The deceased leaves a widow and two grown sons, the eldest of whom, Richard Everett, has for the past six years been a traveling salesman for the Dennison Mfg. Co.

A great saving of time may be effected by the use of the engravers' type recently placed on the market by Wm. H. Dietz, 117 Dearborn St., Chicago. The rubber type are made on a new principle and have perfect alignment. By their use all tracing is done away with, the outlines being stamped on the articles in clear cut letters which may easily be followed by even the apprentice. They solve the question of "engraving made easy," and are a useful adjunct to every engraver's bench.

**ANNOUNCEMENT.**

Owing to mechanical obstacles encountered in stamping a design of circular shape upon certain articles, the original Trade Mark of the **HOWARD STERLING COMPANY**, consisting of a four leaf clover surrounded by the letters composing the word Sterling in horseshoe form, has been modified.

An illustration of the new Trade Mark which will in future be stamped on all goods of our make is herewith presented.



TRADE MARK.

**Howard Sterling Company, Providence, R. I.**



### The Trial of the Springfield Thieves Postponed.

SPRINGFIELD, Mass., April 28.—Samuel Goodman and Henry Parker were in police court Tuesday, when their cases were called, but there was no trial, a postponement being made until Wednesday, May 2d. The postponement was caused by the inability of the prisoners' lawyer to be present and because City Marshal Rice asked for more time in order to get one of his witnesses from the west.

Both prisoners strongly objected to the procedure and asserted that the court was not showing fair play in continuing the case and keeping them in jail where they had no chance to secure witnesses and otherwise prepare a defense. The judge told them that the case was put over at the suggestion of their attorney, J. R. Thayer, of Worcester, but both maintained that they had no counsel and wanted an immediate trial. They were very sarcastic in their remarks but the case went over just the same. It appears that Thayer was engaged by some of the Worcester friends of the prisoners and they did not know of it.

#### ONE OF THE THIEVES IDENTIFIED AS HENRY McCANN.

WORCESTER, Mass., April 27.—Henry Parker, one of the diamond thieves arrested in Rochester, N. Y., for robbing H. C. Barnum's trunk in Springfield, has been positively identified as Henry McCann, son of Ross McCann, of this city. Officer Fyrborg of Station 1, has gone to Springfield as a witness in the case against McCann, as he saw him in this city about the time of the diamond robbery.

McCann is 26 years old, and has been under suspicion as one of the transom burglars who created such a scare two years ago. McCann has not been in this city to any extent for more than five years. He was in New York the day before the diamond robbery, and again was in New York five days later. At that time he was with a man whom his brother did not know. Later it was learned that the man was Cote and it is believed he met him in Boston the day before the robbery.

### Simon M. Jacobs, Accused of Larceny, Arrives in New York.

SAN FRANCISCO, Cal., April 24.—Simon M. Jacobs, the diamond salesman accused of embezzling a lot of diamonds, left for New York with Detective McNaughton last night.

Simon M. Jacobs, who is under indictment charged with stealing diamonds he had obtained on memorandum from Ludeke & Power, 23 John St., Shultz & Rudolph, 24 John St., and Stern Bros. & Co., John and Nassau Sts., reached New York Sunday afternoon, from San Francisco, in custody of Central Office Detective Sergeant McNaughton.

Jacobs was arrested in San Francisco on April 9th, on a telegram from Inspector McLaughlin. An account of Jacobs' stealings was given in THE CIRCULAR of April 18th.

### Interesting Convention of the Alabama Retail Jewelers' Association.

BIRMINGHAM, Ala., April 27.—The Retail Jewelers' Association of Alabama, held their second annual meeting in Elks Hall, in this city, on the 25th. There was a good attendance, nearly all the fifty-five members being on hand. In the absence of president J. L. Schweizer, Selma, vice-president J. C. Welch, Uniontown, presided. Secretary William Rosenstihl presided at the desk.

The meeting was to have been held last October, but was postponed on account of the postponement of the Confederate Reunion, it being desired to hold the association meeting during the reunion, in order to get a large attendance.

The reports of officers were received and referred to proper committees. New members were admitted as follows: H. R. Robinson, Anniston; Apsey & Co., Eutaw; and W. F. Spurlin, Camden.

The finance committee composed of D. G. Hall, H. C. Abbott and A. Speaker investigated the books of the secretary and treasurer and reported them in good condition. The report was accepted and the thanks of the association returned to the two officers.

Many questions of interest to the trade were discussed. The indiscriminate distribution of catalogues by certain firms was condemned. The most important step taken by the association was that of joining the National Retail Jewelers' Association. The membership fee will be sent on at once. The National Association will hold their next meeting in Cincinnati, O., on the second Tuesday in July, and the following were chosen to represent the Alabama Association: J. C. Welch, Uniontown; William Rosenstihl, Birmingham; C. L. Ruth, Montgomery; alternates: J. T. Moye, Oxford; H. C. Abbott, Birmingham; and William Black, Birmingham.

The election of officers for the ensuing term resulted as follows: President, E. H. Hobbs, Selma; first vice-president, J. C. Welch, Uniontown; second vice-president, William Black, Birmingham; secretary, William Rosenstihl, Birmingham; treasurer, H. C. Abbott, Birmingham; directors, W. H. Welch, Demopolis; E. H. Hobbs, Selma; F. L. Zimmerman, Troy; Otto Stoelker, Montgomery; and George A. Poetz, Mobile.

Section 1, Article 1, of the constitution was amended so as to change the date of meeting from the second Tuesday in July of each year to the second Tuesday in May of each year. This was done so as to enable the Alabama Association to meet just prior to the National Association's convention. The committee on resolutions reported the following which were adopted:

*That we condemn the indiscriminate distribution of catalogues and price lists, and will confine our purchases to houses who only seek the legitimate jeweler for the sale of wares pertaining to his trade.*

*That we confine our purchases to houses who do not retail.*

It was decided to send a written request to all manufacturers of goods pertaining to the legitimate jeweler to cease paying for advertisements in the daily and weekly papers of the United States, of articles of their manufacture, and further request that they cease the publication of net price lists in the trade papers.

THE JEWELERS' CIRCULAR was thanked for their kindness in publishing full and reliable reports of the association's meetings and other news pertaining to the jewelry trade in this State.

The next place of meeting will be decided upon by a mail ballot.

In attendance at the meeting was W. L. Spurlin, the oldest native Alabamian in the association. He comes from Camden. For 43 years he has been in the trade in the town of Camden, and in the State he has worked among the intricate points of the trade for 49 years, and is still at the business. He is a very pleasant old gentleman, and a most enthusiastic member of the association.

Much regret was felt at the absence of J. L. Schweizer, the retiring president of the association. He was one of the moving spirits in its organization, but was unavoidably prevented from attending this meeting.

The Alabama Association is only a little more than two years old, but it is full of life and vigor. Its membership numbers 55 embracing all the prominent jewelers in the State. The membership is constantly growing and the prospects for the future are most flattering. Now that the association has joined the National organization, it will take on new life.

William Rosenstihl, Union Springs, father of Rosenstihl Bros., of Birmingham, was not present in person but was there in thought and by proxy. He celebrated his fiftieth anniversary at the bench on March 25th. Mr. Rosenstihl worked for the trade in New York city during the years of 1855 to 1860, for old and well-known jewelers such as Tiffany & Co., Ball, Black & Co., Brunner & Son, T. B. Bynner, Benedict and others. He has all these years kept the record of his repairs done at that time, which number thousands of watches and he refers to it many times with great pleasure.

E. H. Hobbs, the new president of the Alabama Association is one of the most prominent jewelers in the State. He has been in business in Selma for many years and has prospered.

Reed & Barton say they never had a man in their employ by the name of Fred. Dennett, who it was reported last week had severed his connection with that house.

Louis Gardner and George Reinhardt are in jail at Burlington, Ia., for 15 days, on a charge of carrying concealed weapons. When arrested they had a miscellaneous lot of jewelry, apparently stolen, in their possession, including a gold and a filled watch, chains, rings, etc.



**Dulness of Business Causes Thomas Yost & Son to Assign.**

FRESNO, Cal., April 25.—The jewelry firm of Thomas Yost & Son have for some time been reducing stock with the view of going out of business, but owing to dull business have now assigned.

The firm paid off all their creditors except about a half dozen and then notified these of the situation of affairs and their inability to convert the stock into cash to advantage and asked them to take charge of it to protect their claims. J. P. Le Count, of Le Count Bros., San Francisco, came up as a representative of the creditors and assumed control of the property. Mr. Le Count said to a reporter that the firm might have continued on for months until the assets were absorbed in expenses, and left the creditors without pay or property out of which to make their money. An inventory had been taken showing the assets of the firm to be \$9,500 while the indebtedness amounts to \$5,000.

The creditors appreciate the course of the firm and Mr. Le Count says they will all be paid in full, and he expects a substantial balance to the firm notwithstanding the low prices at which the goods will be sold.

**A Workman Charged With Stealing Gold.**

PHILADELPHIA, Pa., April 27.—William Schleich, 2233 S. 9th St., was charged before Magistrate Milligan at the Central Station yesterday with the larceny of gold clippings, valued at \$3 from the watch case factory of Bernard Levy, 130 S. 9th St., where he was employed as a pressman. Mr. Levy stated that he had been missing gold for over eighteen months, but was never able to discover the culprit until now. Schleich, although denying all knowledge of the matter, was held in \$500 bail for his appearance in court.

M. Levy's testimony was to the effect that on Friday during the melter's absence from the melting room the gold clippings were stolen from the crucible. From the fact that Schleich had been seen in the room he suspected that he was the offender. Calling him into his office, he charged him with the crime, and Schleich made an absolute denial. He then proceeded upstairs, and was seen, it is alleged, to go into the toilet room. After he had left a plumber was called in to examine the trap. He found the missing gold. Witness further stated this sort of thing had been going on for for some time, but he could not determine exactly how much had been taken. Schleich, he said, had been in his employ for something over two years and he never had any reason to suspect him before.

Schleich, when asked what he had to say, denied the theft, and said he had only been in the factory five or ten minutes when he was called into Mr. Levy's office.

J. P. Powell, of Troy, N. Y., has opened a jewelry store in Greenwich, N. Y.



**Great Reduction in Watch Glasses.**

To make room for a large Stock of W. B. & C. Watch Glasses, which is the only kind we are going to keep, we will sell out our Stock of Blue Label Glasses at following prices:

GENEVAS,	=	=	=	=	at \$1.40 per gr.
MI CONCAVES,	=	=	=	=	1.80 " 6% for Cash.
PAT. GENEVAS,	=	=	=	=	3.40 "

**NOW IS THE TIME TO STOCK UP.**

We carry a full stock of Tools and Materials at the lowest prices. And also give strict and prompt attention to repair work of all kinds for the trade, thus enabling our customers to save time, trouble and Money by concentrating their orders.

**FISHER & SONS, 63 NASSAU ST., New York.**

SAM'L SONDEHEIM, 20 JOHN STREET.

IMPORTER OF DIAMONDS.

*New York, May 1st, 1894.*

*I take pleasure in informing my friends and the trade in general that I have established myself as an IMPORTER OF DIAMONDS at No. 20 John Street.*

*Yours respectfully,*

**SAM'L SONDEHEIM,**  
FORMERLY OF BRUHL BROS. & CO.

**HAGAN, WHITE & CO.,**  
MANUFACTURERS OF  
**GOLD AND SILVER MOUNTED CANES, UMBRELLAS & NOVELTIES.**

RICH AMERICAN CUT GLASS, SILVER MOUNTED.  
248 WEST 23D STREET, NEW YORK.

—OUR OWN—

**"COLUMBIAN"**

Fifty Punch Staking Tool, LEADS ALL OTHERS in STYLE, FINISH and ACCURACY. Hundreds of practical Watch Makers pronounce it the BEST. Nicketed frame, mahogany base, extra fine tempered steel punches and stumps.

◆◆◆ FULLY WARRANTED. ◆◆◆

*For full description send five cents in stamps with business card, for New Catalogue of OVER ONE THOUSAND varieties of fine Watch and Bench Tools of OUR OWN MAKE, many entirely new.*

O. W. BULLOCK & CO., Springfield, Mass.

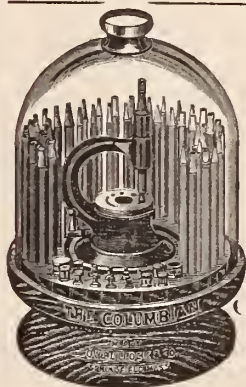

**McIntire, Ulmer & Co.,**

WHOLESALE OPTICIANS  
127 SO. 8TH STREET, PHILA., PA.

**PRESCRIPTION : SPECIALTIES.**

Best Work. Low Prices. Prompt Service.





### Boston.

P. Merrick Harwood has returned from a ten weeks' outing in California.

At the funeral of the late C. A. W. Crosby the jewelry trade was represented among the pall-bearers by D. C. Percival and Edward Rivett.

General manager Rufus B. Carr, of the E. Howard Watch & Clock Co., has been on a business visit to New York since Thursday last.

J. H. Wilkins, of the bookkeeping department at D. C. Percival & Co.'s, severed his connection with the house May 1st, to engage in business for himself in another line.

Mrs. Cowan, wife of jeweler E. A. Cowan, who was seriously injured in a Texas railway accident a few weeks since, has been brought home from San Antonio and is slowly improving.

The American Soda Fountain Co. have declared quarterly dividends of 1½ per cent. on 1st preferred, 2 per cent. on 2d preferred, and 2½ per cent. on common stock, all payable May 4.

The E. Howard Watch & Clock Co. will erect an illuminated church tower clock, with four 5½ ft. dials, in St. Albans, Vt.; also a striking 4-dial church tower clock in Cranford, N. J.

Stephen Bennett, one of the best known watch dealers of the old school in the city

still in active business, received wishes for many happy returns of the day from his friends among the jobbers on passing his 74th milestone Thursday.

William E. Geyer, salesman for D. C. Percival & Co., launched his new yacht, *Onaway*, one evening last week, a number of the "boys" in the establishment being present to witness the event and assist at the ceremonies.

H. M. Rich & Co., jewelers' auctioneers, 61 Hanover St., conducted successful sales during April for A. J. Welty, Carlisle, Pa.; W. H. Elliott & Son, Manchester, N. H.; G. H. Doyle, Lynn, Mass.; J. P. Fogg, Woburn, Mass., and E. W. Mitchell, Waco, Tex.

An announcement, recently published, of the bequests of the late F. J. White, a Chicago jeweler, who died April 10th, stated that \$10,000 had been left to his niece, Mrs. Henry A. Yeo, of 995 Washington St., this city. Mrs. Yeo states that this is erroneous, and that the amount bequeathed her was \$4,000.

### Philadelphia.

David F. Conover has been resting for a few days in Atlantic City.

Bernard Levy, Jr. started upon his first professional trip, through Pennsylvania, on Saturday last.

Frank L. Archambault is rapidly getting his new store at 101 S. 11th St., in shape

and will occupy it about the beginning of May.

It is stated that Samuel Biddle, formerly of the firm of Bailey, Banks & Biddle, will be the president of a new bank, soon to be organized and to be known as the Ridge Ave. National Bank.

Edward T. Taylor, 1020 Chestnut St., has announced himself as a candidate for delegate to the Republican State Convention from Teadon, Delaware County, where he resides. Mr. Taylor is a member of the Young Republicans, Philadelphia Republican and Union Republican Clubs.

The auction sale of the stock of C. R. Smith & Son, preparatory to the firm entering exclusively upon the manufacture and retailing of silver and silver-plated goods, was abandoned after one day's trial, on the 23d ult. The result was not as satisfactory as had been anticipated.

### Canada and the Provinces.

M. Parker, representing A. C. Anderson & Co., Toronto, was in Montreal last week.

W. A. Dickson, Notre Dame St., Montreal, has gone to Hamilton for a few days.

The stock of Emile Valot, Montreal, is advertised for sale by the bailiffs.

J. A. Pitts, Montreal, has returned from a successful trip through eastern Ontario.

George Chillas, Montreal, has returned from a trip to New York, Boston, Halifax and St. John, N. B.

The jewelry firm of W. S. Walker, Montreal, have removed to their new premises on St. Catherine St.

The store of the Manitoba Jewelry Co., Winnipeg, Man., was burglarized last Tuesday night, the burglars getting away with \$350 worth of jewelry.

Suckling & Co., of Toronto, will commence to sell the stock of J. Moodie & Sons, Hamilton, to-day May 2. The stock comprises \$26,000 worth of silverware, wools and woolens, embroideries, and general fancy goods. The business is being sold because the owner wishes to retire.

A new electroplating business has been established in Winnipeg. It is known as the Winnipeg Electro Plating Co. A. C. Foster, who is well-known throughout the west as a commercial traveler, is manager of the business, and S. B. Owen, of Chicago, has been engaged to take charge of the practical work.

### Jeweler Dannenbaum Wants \$10,000 for His Good Name.

WILKESBARRE, Pa., April 27.—Suit was commenced yesterday by Daniel Dannenbaum, jeweler, 183 E. Market St., against Joseph Liebson, for damages of \$10,000. The statement of the plaintiff is that Liebson brought a watch to his place for repair, and that after he took it away took out the works and substituted inferior ones, and proclaiming Dannenbaum a thief. The plaintiff has retained Attorney John T. Shea as counsel. Mr. Liebson is a member of the firm of J. & N. Liebson, of Scranton.

## Now Is Your Chance.

Every progressive watchmaker and live Jeweler, who wishes to keep abreast of the times and be posted in all new and meritorious inventions pertaining to his trade, now has the opportunity of procuring that latest triumph, the "Charmilles" Watch, as they are on the market. They don't cost much. To purchase one is MONEY WELL SPENT. To take one down, study its mechanism and familiarize yourself with its novel and superior construction, IS A PLEASURE. As a progressive watchmaker and merchant,

IT IS YOUR DUTY.

ORDER FROM YOUR JOBBER.



# The Jewelers' Circular

AND  
HOROLOGICAL REVIEW.

PUBLISHED EVERY WEDNESDAY BY  
**THE JEWELERS' CIRCULAR PUB'G CO.,**  
189 BROADWAY, NEW YORK CITY.

A JOURNAL DEVOTED TO THE INTERESTS OF JEWELERS, WATCHMAKERS, SILVERSMITHS, ELECTRO-PLATE MANUFACTURERS, AND ALL ENGAGED IN KINDRED BRANCHES OF INDUSTRY.

Our Editorial columns will contain our own opinions only, and we shall present in other columns only what we consider of interest or value to our readers. Advertising matter will not be printed as news.

Advertising rates in THE CIRCULAR are lower, considering the number of tradesmen reached by its large circulation, than in any other jewelry journal.

Notices of changes in standing advertisements must be received one week in advance; new matter can be received up to Monday.

## INFORMATION FOR SUBSCRIBERS.

### Terms of Subscription, Postage Prepaid.

	PER ANNUM
United States and Canada, . . . . .	\$2.00
Foreign Countries in Postal Union, . . . . .	4.00
Single Copies, . . . . .	.10

New subscribers can commence at any time. Payments for THE CIRCULAR, when sent by mail, should be made in a Post-Office Money Order, Bank Check or Draft, or an Express Money Order or Registered Letter. All postmasters are required to register letters whenever requested to do so.

Pay money only to authorized collectors having proper credentials. Returning your paper will not enable us to discontinue it, as we cannot find your name on our books unless your address is given.

In changing address always give the old as well as new one. Your name cannot be found on our books unless this is done.

We will continue to send papers until there is a specific order to stop, in connection with which all arrearages must be paid; but such an order can be given at any time, to take effect at the expiration of the subscription. All such orders will be promptly acknowledged by mail.

The Courts have decided that all subscribers to journals a responsible until arrearages are paid in full and an order to discontinue has been received by the publisher.

Member of the American Trade Press Association.

VOL. XXVIII. May 2, 1894. No. 13.

## Progress in Silver Legislation.

SOME progress was made last week toward the adoption by the several States of legislation to regulate the stamping, marking, or branding of silverware. The bill passed by the Legislature of Massachusetts was signed by Gov. Greenhalge, while the measure introduced in the Senate of New York was passed by the Assembly, and awaits only Gov. Flower's approval. If Rhode Island adopts the law before its Legislature, the quality of fully 75 per cent. of the silver ware and silver jewelry now produced in the United States will be regulated by statute, the laws in the three States being essentially similar. This condition is highly desirable as far as it goes, but it does not go quite far enough, for unless the other States of the Union adopt similar amendments, it is not unreasonable for us to expect to be made aware of the existence of factories in these States whose spurious product will prove a baneful competitor of the legitimate product of the other States. It is hence incumbent

upon the jewelers of these States to urge their Legislatures to pass laws respecting silver manufacturing similar to those of Massachusetts and New York. As the several States adopt such legislation, the field of operation for the manufacturers of fictitiously marked silverware will become more and more limited, till a point is reached where it is unprofitable for any one to produce it. A National law, were its passage possible, would prove the most effective, but remembering the career of the Torrey Bankruptcy bill and the numerous obstacles put in the way of the passage of National measures, a satisfactory state of affairs can be more rapidly reached by the States individually passing "sterling silver" laws.

## The Passage of the Tariff Bill.

THE imposing list of names appear under a call for a mass meeting at Cooper Institute, New York, on Thursday evening, to make formal request upon the Senate for the immediate passage of the Tariff bill, is an eloquent testimony of the impatience of the business community with the dilatory conduct of that body. Most of the signers are naturally Democrats, few Republicans being willing to put themselves on record in favor of a tariff reform bill; but there is no doubt that thousands of Republicans would rather see the bill pass at once, and thus give the country a settled basis upon which to transact its business, than have the uncertainty maintained any longer. Taken in connection with the protests from Democratic organizations, journals and individuals in other parts of the country, the meeting ought to have the effect sought.

## Diamond Production and Labor.

IT is reported from South Africa that much consternation has been caused by the announcement that the De Beers Consolidated Mines Co. have found it necessary to discharge between 100 and 250 of their European employees. The reasons assigned by the management are two-fold: first, it is estimated that £4,000,000 worth of diamonds is on the floors, and consequently the output must be restricted; second, that the recent discovery of diamonds in Australia is regarded as a serious matter. The company maintain that there has been overproduction of diamonds recently. The floors, as far as they can extend, are choke full of blue ground, while hauling is restricted. It seems to be a question of supply and demand, and in this matter stern necessity requires that the wage payers should study the interests of their employees. With such a marketable commodity as the diamond, one can scarcely see how the most generous regulations of co-operation or the most clamant laws of humanitarian socialism, could judiciously affect the labor market, either in contracting or in enlarging it. The diamond production, unlike that of wheat, or wool, or gold, must be regulated by the rule of demand.

## The Week in Brief.

THE annual meeting of the Retail Jewelers' Association of Alabama was held in Birmingham, Ala.—An appeal was taken from the decision of Judge Coxe, in the suit of Dueber Watch Case Mfg. Co., against the manufacturers of movements and cases—Interesting tariff decisions were handed down—The death occurred of George W. Bacon, Newfield, Conn., an old time manufacturer of britannia ware—A trustee was appointed for the estate of the Manhattan Watch and Jewelry Co., New Haven, Conn.—Voley Isbel, Lockhaven, Pa., died—A meeting of the creditors of Henry T. Spear & Son, Boston, Mass., was held—The Governor of Massachusetts signed the bill regulating the manufacture and sale of silverware—A settlement was effected in the affairs of Strauss & Stern, Cincinnati, O.—Three spectacle fakirs were arrested in Saginaw, Mich.—Wm. Ulrich, Detroit, Mich., filed a chattel mortgage in favor of Eugene Deimel—A gang of daring burglars was captured in Pennsylvania—The trial of Samuel Goodman and Henry Parker, charged with robbing H. C. Barnum, traveler for Shafer & Douglas, New York, was postponed—Offers in composition were made by the assignee of George C. McCormick & Co., Providence, R. I.—Thomas Yost & Son, Fresno, Cal., assigned—A workman in the factory of Bernard Levy, Philadelphia, Pa., was charged with stealing gold—The Stilson & Collins Jewelry Co., Atlanta, Ga., incorporated—A safe fell from the 12th floor of the Sheldon building, New York—The death occurred of Richard L. F. Everett, formerly of Bliss Bros. & Everett, Attleboro, Mass.—The business of Harold Dyrenforth, Chicago, was closed under a mortgage.

## Offers in Composition of George C. McCormick & Co.

PROVIDENCE, R. I., April 30.—A. J. Cushing, assignee for Geo. C. McCormick & Co., has sent a circular to the creditors in which he states that the total liabilities are \$18,501.08; assets nominal value, stock \$7,711.85; bills receivable, \$9,971.32; fixtures, \$610; actual value, stock, \$3,855.93; bills receivable, \$3,831.94; fixtures, \$305; total nominal value, \$17,143.17; actual value, \$7,992.87. The following offers of compromise are made: 25 per cent. cash within 30 days after May 1st, or 35 per cent. divided as follows: 5 per cent. within 30 days after May 1st, balance in three unsecured notes of 10 per cent. each payable in four, eight and twelve months respectively, from May 1st. He further states that a committee of the Manufacturing Jewelers' Board of Trade have examined the affairs of the concern and their figures vary but slightly. It is reported that the offer of 25 per cent. is the most favorably considered, and is being generally accepted.



### New York Notes.

S. F. Myers & Co. have entered a judgment for \$256.40 against Thomas Roberts.

Auctioneer J. H. French concluded a sale of bric-à-brac at 176 Broadway, Saturday.

M. J. Averbeck, of Averbeck & Averbeck, will sail for Europe May 9th on the *Britannic*.

Leopold Stern, of Stern Bros & Co., sailed for Europe, Wednesday, on the *Paris*.

A judgment for \$600.07 against Benj. S. Wise and Louis Heim has been entered by Sig. Hirschberg.

Sig. Hirschberg has entered a judgment for \$232.67 against Benj. S. Wise, Louis Heim and Eliza J. Tower.

A judgment against Ludwig Hess for costs amounting to \$70.47 has been entered by the Liberty Machine Works.

Henry H. Jacobson, of Jacobson Bros., sailed for Europe Wednesday on the *Paris*. He will be gone about two months.

Solomon Bachrach has entered judgments against Jacob Goldstein for \$211.25 and against Aaron Kaplan for the same amount.

L. Combremont, importer of jewelers' tools, formerly of 182 Broadway, removed Wednesday to his new quarters at 45 Maiden Lane.

The six-story building at 90 Nassau St. was recently purchased by G. Armeny, of Armeny & Marion, whose offices are situated on the second floor.

Blooma Folkart, 473 Fulton St. and 186½ Bergen St., Brooklyn, has given a chattel mortgage on jewelry fixtures for \$450, to J. W. Block & Bro., of this city.

John B. Cook, a brother of Chas. T. Cook, of Tiffany & Co., died Friday morning, at his home, 17 W. 83d St., after an illness of three weeks. He was 53 years old.

The Alvin Mfg. Co. removed yesterday from 860 Broadway, to their new quarters at 4 Maiden Lane, where they occupy the store in conjunction with J. T. Scott & Co.

The stock of Julia and Ludwig Hess, jewelers at 247 Grand St., who did business under the style of the Manhattan Watch and Jewelry Co., was sold by the sheriff Monday.

The Pairpoint Mfg. Co. have removed their New York branch from 20 Maiden Lane, into the store occupied by the Mt. Washington Glass Co., at 46 Murray St. Both are now in charge of Wm. H. Lum.

President Max J. Lissauer, of the Jewelers' Relief Association, has called a meeting of the full committee of 25, for this afternoon at 2.30 o'clock. Reports of the work of the various sub-committees will be submitted.

Annie Bernhard, of 138 Monroe St., was taken to the insane ward of Bellevue Hospital Thursday. Her insanity was said to have been caused by the marriage of Isidor Goldberg, a jeweler, a former lover who had jilted her.

In the Jefferson Market Police Court, Wednesday, Justice Ryan sentenced Leo Roget, a French diamond cutter, to six months on Blackwell's Island. Roget was accused of leading an assault on two detectives while the latter were serving a warrant.

Samuel Gompers, president of the American Federation of Labor, recently addressed the members of Local Assembly No. 3,401, of the Knights of Labor, the Watch Case Makers' Union, in their hall, 407 Bridge St., Brooklyn. Two other members of the Federation also spoke.

In the suit of Sinnock & Sherrill against Chas. S. Platt, Judge Lawrence, of the Supreme Court granted an order last week which, pending the defendant's appeal to the General Term from the order compelling him to submit his books for an inspection, stays all proceedings under that order until after the General Term's decision.

The funeral of Thos. Loton, who for a quarter of a century or more kept a fruit and liquor store at 194 Broadway, took place Thursday from his home, 28 W. 59th St. The interment was in Calvary Cemetery. Mr. Loton was well-known to the jewelers in the vicinity of John St. and Maiden Lane.

Miss Louise Alexander, the young woman employed as a detective at A. F. Jammes' notion and jewelry store, 907 Broadway, Thursday caused the arrest of a woman whom she accused of stealing a ring set with brilliants. The woman gave her name as Bessie Jones, of 36 Leroy St. She was locked up in the W. 30th St. station.

A passenger on *La Touraine*, named Alexander, was captured by special customs inspectors last week, while attempting to smuggle a number of articles which he had hidden under his coat. Among the goods seized were two gold watches and chains, five silver napkin rings, and three silver stencils. The agents took these, and Alexander went away. The articles were on exhibition at the Custom House seizure room last week.

Wilber & Oldham, attorneys for the Dueber Watch Case Mfg. Co., have appealed to the United States Circuit Court of Appeals from the decision of Judge Coxé recently mentioned in *THE CIRCULAR*, which sustained the demurrers of the E. Howard Watch & Clock Co., the Bay State Watch Case Co., and Jas. H. Noyes, to the actions brought by the Dueber Co. in the United States Circuit Court, against the manufacturers of watch movements and cases.

Among the decisions recently handed down by the Board of United States General Appraisers, was one in the case of A. Frankfield & Co., *vs.* Collector at New York on jewelry, imported Sept. 19, 1893. The merchandise consisted of gold watch charms having cigar cutting attachments, also pocket knives. Duty was assessed upon the former as smokers' articles and upon the latter as pocket knives. The importers

desired the merchandise to be classified as jewelry, but were overruled. In the appeal of L. Hammel in relation to the duty on coverings for opera glasses, the ruling of the Collector at New York was also sustained.

### A Safe Crashes Down 12 Stories of the Sheldon Building.

An accident which seriously inconvenienced the tenants of the Sheldon building, Nassau and John Sts., New York, besides injuring one man and causing considerable damage to the building, occurred about 1 o'clock, Monday afternoon. The accident was due to the falling of a safe for the offices of the New York Jewelers' Board of Trade on the 12th floor, which was being put in by the Herring-Hall-Marvin Co.

The safe was hoisted up the south elevator shaft and the rope passed down the shaft and through the hall on to the truck in front of the entrance. The safe had been lifted up to the 12th story and was about to be pulled on the landing when suddenly the crank wheel of the windlass on the truck broke, and the heavy safe fell with a crash down the shaft. It dropped seven flights before it struck and then bumped from side to side demolishing the shaft until it reached the cellar.

Frank May, one of the workmen on the truck, was severely injured by flying pieces of the broken wheel and taken to Chambers Street Hospital. The accident caused the other elevator to stop, much to the disgust of the tenants on the upper floors. A representative of the agent of the building stated that the damage to the building is about \$5,000.

### Last Week's Arrivals.

***THE CIRCULAR* has perfected arrangements for obtaining the names and hotel addresses of all the latest buyers visiting New York, and each day posts in its office, 189 Broadway, a bulletin which every member of the trade is cordially invited to copy.**

The following out-of-town dealers were registered in New York during the past week: F. Harth, Danbury, Conn., Grand Union H.; L. Hill, Chicago, Ill., Astor H.; R. J. Satterthwait, Charleston, W. Va., Astor H.; C. C. Sigler, Cleveland, O., Astor H.; J. T. Sipe, Cleveland, O., Astor H.; V. J. Pekor, Columbus, Ga., Sturtevant H.; A. Martin, Philadelphia, Pa., Cosmopolitan H.; C. T. Moore, Washington, D. C., Astor H.; T. M. Knight, Philadelphia, Pa., St. Stephen H.; A. Lathrop, Syracuse, N. Y., Astor H.; A. J. Logan, Waltham, Mass., Astor H.; W. H. Severance, Lowell, Mass., St. Denis H.; J. C. Barnum, Buffalo, N. Y., Astor H.; C. H. Dimmick, Binghamton, N. Y., Astor H.; A. Jarecki, Erie, Pa., St. Denis H.



**Providence.**

H. J. Covell has started in business at 65 Westminster St.

S. E. Budlong & Co. have opened a New York office at 194 Broadway.

B. Eckstein, New York, was in town the past week calling upon the trade.

D. A. Riddle has been admitted as a member of the firm of J. G. Fuller & Co.

Walter Gardiner, of D. Wilcox & Co., is convalescing from his recent attack of sciatica.

A. S. Weaver & Co. have added a large line of optical goods to their stock at 74 N. Main St.

Louis V. Guertin is building a handsome residence on Pleasant View, Pawtucket, at a cost of \$5,000.

John Gibson, formerly of William Hamilton & Co., is now in the periodical business on Cranston St.

Walter F. Willis was married to Miss Agnes M. Kalloch, daughter of Dr. Robert Kalloch, at the latter's residence in New York, on the 25th inst.

Thomas Gorton has started in business at 15 N. Main St. H. J. Tetzloff, for several years with Herman Ockel, will have charge of the watch department.

David Bernkopf is erecting a handsome new house in this city in which he will reside with his bride immediately after his return from his wedding tour.

The New England Loan Co., M. Sundal-

ervitch, manager, has started in business at 141 Charles St. The store of Mr. Sundalervitch was burned out a short time ago.

The business of L. Dimond & Son, corner Chalkstone Ave. and Charles St., who carry a considerable stock of jewelry, was considerably damaged by fire on Thursday evening.

Henry G. Thresher, of Waite, Thresher Co., has the sympathy of a large circle of acquaintances at the death of his only child, Earl Clifford, Sunday by scarlet fever, after an illness of but one day. His age was three years.

At a meeting of the creditors of William H. Eaton, 20 Broad St., Pawtucket, held at the office of Assignee Blodgett, on Wednesday morning, a statement of assets and liabilities was made together with a proposition of 30 cents on the dollar.

Among those who responded to toasts at the 119th anniversary banquet of the United Train of Artillery of this city last Monday evening were Theodore A. Barton, George Becker and Lewis Patstone. The latter was later elected as captain of the command.

George O. Cowell, of the firm of Cowell & Hall Mfg. Co., Wrentham, Mass., but a resident of this city, was taken suddenly insane last week and was obliged to be placed under restraint. He had a severe attack of the grip a few months ago which resulted in his present condition.

The following item published last week in THE CIRCULAR is erroneous: "Miss Anna

Foster, daughter of Theodore W. Foster, of Foster & Bailey, will be married to Dr. Morrison, of this city, early in June." The young lady referred to is Miss Anna Bailey, daughter of Mr Bailey, of Foster & Bailey.

Owing to mechanical difficulties in stamping the old trade mark, the Howard Sterling Co., Providence, R. I., have adopted the trade mark as shown in their announcement on another page. Like the old, the new trade mark will be a guarantee of standard quality and the best workmanship. The Czarina sugar divider which will shortly be put on the market by this house is something which will be at once appreciated by the trade, while the dainty Hexagon pattern colonial coffee services made by the Howard Sterling Co. are already famous as one of the handsomest patterns on the market.

The popularity of the Meriden Britannia Co.'s Romanesque pattern increases in proportion as it becomes known. A new thing just ready is a patented ink-stand, the Columbian, in quadruple silver plate, so arranged that the pen can not be dipped too deeply, cannot strike the bottom and takes only fresh ink fed from the bottom by an ingenious device. The large salesroom at the company's factory is undergoing extensive alterations and decoration which will make it, when completed, much lighter and afford a better display of the many samples.

**L. TANNENBAUM & CO.,**

**Importers and Cutters of DIAMONDS AND PRECIOUS STONES,**

COR. MAIDEN LANE & NASSAU ST., NEW YORK.

Telephone, Long Distance, 1959 Cortlandt.

25 HATTON GARDEN, LONDON.

**EMERALDS.**

2,77	1 Emerald,	1 26-64 kt.,	\$30.00 per kt.
22,77	1 "	1 17-64 kt.,	28.00 "
30,77	1 "	3 22-64 kt.,	55.00 "
9,79	1 "	1 58-64 kt.,	16.00 "
25,79	4 "	3 37-64 kt.,	65.00 "
23,79	6 "	2 13-64 kt.,	18.00 "
32,79	3 "	2 24-64 kt.,	5.00 "
7,377	10 "	16 7/8 kt.,	20.00 "
4,367	116 "	35 18-64 kt.,	30.00 "

**RUBIES.**

1,167	Rubies,	13 17-64 kt.,	\$8.00 per kt.
2,167	"	19 1/4 kt.,	8.00 "
4,167	"	17 less 1/8 kt.,	5.00 "
5,128	1 Round Ruby,	1 30-64 kt.,	40.00 "
6,128	1 Ruby,	1 14-64 kt.,	50.00 "
30,335	1 Star Ruby,	2 1/4 kt.,	125.00 per stone
14,335	12 Rubies,	6 4-64 kt.,	14.00 per kt.

**SAPPHIRES.**

15,115	1 Sapphire,	1 33-64 kt.,	\$45.00 per kt.
1,416	1 "	1 54-64 kt.,	45.00 "
2,416	1 "	1 36-64 kt.,	65.00 "

11,416	1 Sapphire,	1 38-64 kt.,	65.00 per kt.
29,419	1 "	5 less 4 64 kt.,	20.00 "
7,415	8 "	7 50-64 kt.,	30.00 "
4,416	6 "	7 8-64 kt.,	50.00 "
3,416	2 "	2 36-64 kt.,	50.00 "
2,417	26 Cabochon,	31 10-64 kt.,	20.00 "
3,417	2 Fine Ceylon,	1 26-64 kt.,	30.00 "

**OPALS.**

4,479	1 Opal,	3 56-64 kt.,	\$15.00 per kt.
7,485	16 "	(Heart Shape), 6 44-64 kt.,	8.00 "
329	Fine Opals,	80 38-64 kt.,	15.00 "
1,327	1 "	2 39-64 kt.,	20.00 "
3,327	34 "	66 less 1-64 kt.,	10.00 "
4,327	56 "	88 36-64 kt.,	4.00 "
5,327	48 "	38 16-64 kt.,	5.00 "
6,327	20 "	31 1-16 kt.,	4.00 "
7,327	11 "	5 7-64 kt.,	10.00 "

**CATSEYES,**

3,222	1 Catseye,	8 55-64 kt.,	\$12.00 per kt.
4,222	1 "	10 21-64 kt.,	14.00 "
5,222	1 "	4 20-64 kt.,	30.00 "
28,222	11 "	10 61-64 kt.,	20.00 "
33,222	18 "	37 3-64 kt.,	12.00 "



## News Gleanings.

J. M. Miller has removed from Tania, Ia., to Marshalltown, Ia.

Adolph Mueller has given up the jewelry business in Long Prairie, Minn.

Mr. Haswell, a jeweler, formerly of Youngstown, O., died last week.

C. H. R. Cheney, Stoneham, Mass., is advertising a jewelry store for sale.

Harold Dyrenforth, Chicago, has been closed under a chattel mortgage.

C. W. Collins will soon open a jewelry store in Niles, O.

J. Frank Platts, Dover, N. H., will give up business.

## F. M. Whiting & Co., NORTH ATTLEBORO, MASS.

Sterling Silver Hollow Ware, Flatware,

Novelties, Toilet Articles, &c.

NEW YORK OFFICE,  
1128 B'way & 208 Fifth Avenue.



Handsome New Catalogue showing 22 Patterns in Teas, and 36 Patterns in Coffee Spoons will be mailed on application.

The jewelry stock of J. P. Johnston, Elkhart, Ind., has been taken charge of by E. H. Scott, mortgagee.

W. A. Savage has opened a jewelry store in the Post Office building, in Yates Center, Ia.

Alexander H. Towar, Lyons, N. Y., commenced operations at his new silver plating factory last Monday.

The jewelry store of Fred Knight, Sciota, Ill., was burglarized some nights ago to the extent of \$200.

J. A. Bostwick, jeweler, Cambridge, O., was recently elected a member of the Cambridge Board of Education.

Louis Wertz, of Ottumwa, Ia., was in Foster, Ia., a few days ago looking for a place to start a branch jewelry store.

Jeweler F. A. Jewett, Saugerties, N. Y., has been granted a patent for a rotary display rack.

Cesar Spiegler now occupies his new and commodious quarters at 150 S. Main St. B., Bethlehem, Pa.

Karl B. Kane, formerly with Marshall Field & Co., Chicago, will soon engage in the jewelry business in Vermillion, O.

Marks Goodman, New Orleans, La., has been attached for \$4,288.47, and the sheriff is in possession.

The firm of Austin & Hunter, Belton, Tex., have dissolved partnership by mutual consent. Henry Austin will continue the business.

Wells E. Lackey, for several years past in the employ of R. C. Eldridge, Milford, Mass., has opened a jewelry and optical goods store at 116 Main St., that town.

Dewett R. Edmond, formerly a clerk in Mallory & Hollenbeck's jewelry store, Catskill, N. Y., has gone into business for himself in Steuben County.

H. A. Harrison has opened his new jewelry and stationery store in the Cook block, Sault Ste. Marie, Mich. A brass band was present.

F. J. Stilson, W. R. Collins and E. B. Stilson, of Atlanta, Ga., have incorporated the Stilson & Collins Jewelry Co. to deal in jewelry. The capital stock is \$25,000.

Clinton E. Wyeth, jeweler, Newark, O., was united in marriage a few days ago, to Miss La Merte Keenen, daughter of Frank Keenen, of that city.

Cyrus Condit, who for 10 years has been located in Kansas City, has sold out and will after a few months' vacation locate in or near Boston, Mass.

S. D. Schenck, Binghamton, N. Y., opened his new store, at 29 Court St., on

Monday evening last. During the evening a mandolin orchestra discoursed "most eloquent music."

Fred. Schwob, son of M. Schwob, of Schwob Bros., Montreal, will sail for Europe in a few days in company with his mother.

E. B. Morgan, jeweler, East Stroudsburg, Pa., who recently came off victorious in a suit for divorce brought against his wife, has succeeded in getting the custody of his two children.

Through the efforts of jeweler Mack Hurlbut, all of the jewelry stores in Fort Dodge, Ia., have signed an agreement to close promptly during the Summer at 8 o'clock P. M., except Saturday.

The business of W. L. La Rue, Pittsfield, Mass., has been purchased by Edmund Mc Nerney, and the firm will hereafter be known as W. L. La Rue & Co. The junior member of the firm has been employed in this store for the past five years.

Louis and J. F. Goldsoll have returned to Cleveland, O., and given themselves up to the police. They were wanted for alleged procuring of goods from H. L. Goldsmith, agent for O. M. Draper, New York, on false pretenses. They were released on bail.

## Syracuse, N. Y.

C. N. Damms, jeweler, who has occupied part of the store, 138 N. Salina St., has removed to the store, 218 Montgomery St.

George E. Wilkins spent last week in Geneva, where he received treatment at the Hygienic Institute for an attack of rheumatism.

L. L. Hurwitz, who has been in the jewelry business at 207 E. Fayette St., is disposing of his stock and is going out of business.

Stephen Colwell, one of the oldest residents of this city, lies very ill at his home, 433 E. Washington St., of old age. Mr. Colwell has been in the jewelry business in Syracuse for years, and is said to be the oldest man in the business in central New York. It is a question whether he will recover.

One of the conspicuous removals this Spring is that of E. B. McClelland, who is now occupying his new store in the Dey block on S. Salina St., having removed from 306 S. Warren St. By an ingenious arrangement of portieres and broad stairs in the center, a modern store has been transformed into a charming and convenient jewelry emporium. The front part of the store is devoted to jewelry and silverware which is arranged in handsome mahogany cabinets, and the rear, separated by Oriental hangings, has been made beautiful for the display of art goods, bronzes, marbles, etc. The basement is a store in itself, where crystal and porcelain are displayed on ivory white and under crystal chandeliers. In these new and artistic surroundings Mr. McClelland has collected a most beautiful stock of goods.

## WINDOW IT PAYS

To trim your window from my new and original illustrations, with full and plain directions for placing in window. Send 50c. Postal Note, Window Designer, P. O. Box 105, Wilmington, Del.



**Meeting of the Creditors of Henry T. Spear & Son.**

BOSTON, Mass., April 28.—A meeting of the creditors of Henry T. Spear & Son was held at Young's Hotel, this city, Thursday afternoon. Frank L. Cady, the assignee, presided, and Chris. Morgan, of Rogers & Bro., was secretary.

The assignment recently made by the concern to Mr. Cady was confirmed, and it was voted that the assignee proceed to sell the assets of the firm for the best figures obtainable, at as early a date as possible. Royal E. Robbins, of Boston, and Alfred Barker, of Meriden, were appointed an advisory committee to confer with the assignee in making the sale.

Examination of the books and stock by the assignee shows that the assets, taken at cost price, are valued at \$41,541 and that the liabilities amount to \$53,659.

**The Value of Real Estate on Maiden Lane.**

The principal piece of property sold at the Broadway Real Estate Salesrooms, New York, April 24th, and one which excited most attention was the five story brick building, with store, 11 Maiden Lane. The lot is 18.6½x87.8 and is rented for \$8,000 a year, with leases of all but one floor running to May 1, 1897. The first bid heard was \$100,000, which was increased until \$128,000 was reached, at which figure it was knocked down to Mrs. L. A. Fellows.

This property was purchased in 1845 by William M. Fellows, John Van Arsdale and Joseph M. Cooper, constituting the firm of Fellows, Van Arsdale & Cooper, the best known jewelers of their day. Some years ago the firm dissolved and in the course of time the three members died. The sale last week was in partition, in order to divide the joint estate between the heirs of each member of the old firm. The Fellows interest is represented by the widow, Laura A., and the children of a deceased daughter, who married Henry Dudley; the Van Arsdale interest is represented by Henry V. Parsell, a nephew of the late John Van Arsdale, and the Cooper interest by two sons and a daughter, Marin Le Brun Cooper, Joseph J. Cooper and Agnes Mary Mott.

**A Complicated Fight Over a Rich Quantity of Diamonds.**

The sheriff Wednesday served upon Property Clerk Harriot at Police Headquarters, New York, a writ of replevin for \$10,000 worth of diamonds which Harriot has had in his keeping since the arrest of José Gomez and his wife, in October, 1892, on the charge of swindling Mordecai S. Kaufman, a diamond dealer of John St. Mrs. Gomez, who had previously been acting as an agent for Kaufman, was charged by him with pawning diamonds she had taken to sell on commission. Mrs. Gomez returned the pawn tickets and claimed she had

pawned the jewels with Kaufman's consent. Geo. C. Comstock, who has been retained by some of the pawnbrokers with whom the goods were pledged, to fight the return of the jewels, told a CIRCULAR reporter Friday that this was the second time Kaufman had replevied the jewels from the property clerk. Both writs were worthless, he said, because the clerk could not give up the jewels until after the conviction or acquittal of Mr. and Mrs. Gomez who are now under indictment.

**A Gang of Robbers at Length Brought to Account.**

ALLENTOWN, Pa., April 26.—Through the efforts of Detective Smith, of this city, Constable Doran, of South Bethlehem, and Detective Johnson, of Easton, a gang of robbers is now safely landed in jail here. These robbers have been operating in Lehigh, Northampton, Bucks and other counties in eastern Pennsylvania for several months, and the total value of their plunder amounts to several thousand dollars.

Some months ago the jewelry store of Frank B. Eberhard, this city, was robbed of several hundred dollars' worth of goods. Some time before that Leiter's general store at Hellertown, was robbed of a big lot of goods. Other robberies followed in various places. The four robbers arrested are Henry Meyers, Charles Smith, Henry Burkhardt and William Wagner, each with several aliases. All of Mr. Eberhard's jewelry was recovered.



**EMBLEM**

**GOODS**

OF EVERY DESCRIPTION.

MADE BY THE

**Princess Ring Manufacturers,**

HAYS BUILDING,

21 & 23 MAIDEN LANE, NEW YORK.

ANY WHOLESALE HOUSE IN THE UNITED STATES OR DOMINION OF CANADA, CAN FILL YOUR ORDER FOR THESE CÉLEBRATED GOODS.



THE STAR OF EMPIRE WESTWARD TAKES ITS WAY

# WESTERN SUPPLEMENT OF THE JEWELERS' CIRCULAR

Chicago Office: Room 517, Inter-Ocean Building.

VOL. XXVIII.

CHICAGO, WEDNESDAY, MAY 2, 1894.

No. 13.

## Chicago Notes.

A. T. Evans spent the past week in New York.

A. R. Stanley, of Austin, contemplates a trip abroad.

F. E. Morse Co. moved into their new quarters, 601 Champlain building, May 1.

Manager Loeb, of the Wadsworth Watch Case Co., has returned from a western trip.

Lewis Allen, son of Benj. Allen, who has been studying in Paris the past two years, is expected home about June 1st.

George N. Rouse, Geneva Optical Co., left Wednesday for Missouri and Kansas, his line including the latest improvements in optical specialties.

H. A. Wadsworth, president of the Wadsworth Watch Case Co., refused a cash offer of \$100,000 for his farm on the outskirts of Newport, Ky.

Ed. T. Powers, representing the Meriden Britannia Co., returned from Wisconsin and Michigan early the past week, and left Thursday for Indiana.

M. Krulewich, buyer for the jewelry and optical departments of H. Wolf & Co., 250 Madison St., will start in business on his own account the coming Fall, in San Antonio, Tex.

John C. Balster passed through the city on his way from Hutchinson, Kan., to Petrolia, Ontario. Mr. Balster has sold his business in Hutchinson and will locate in Petrolia.

A severe cold confined L. S. Grout, manager of the Excelsior Sign & Mfg. Co., to his home for the past week. The factory was moved, May 1, to the quarters at the northeast corner of State and Lake Sts.

C. E. Whitehead, son of E. S. Whitehead, a well-known jeweler at 941 Lake St., has opened a jewelry store at 2152 W. Lake St. Mr. Whitehead is a practical watchmaker and carries a general line of jewelry and optical goods.

Walter J. Buckley, representing the Seth Thomas Clock Co., returned Thursday from Texas after placing a tower clock with

2,000-pound bell, in the post office at Dallas. The company have closed a contract for a tower clock for the court house in Hampstead, Tex.

At the regular meeting of Jewelers' Council, No. 316, National Union, April 21st. Chas. A. Barnes, foreman of the silver plating department of the Meriden Britannia Co., was elected financial secretary to succeed Geo. Meehan, resigned.

C. M. Weber, of the Weber Co., is confined to his home by a relapse of the grip, and for several days the past week visitors were denied seeing him. Mr. Weber had been ill for some weeks, and attended to business again contrary to the advice of his physician. Absolute quiet is required, but the illness is not regarded as dangerous.

S. N. Jenkins has purchased the pen repair plant of Joy & Johnson, 71 Washington St., and will combine this branch with the agency for Aikin, Lambert & Co., and move May 1st into his new quarters, 802 Columbus building. Mr. Jenkins will continue to carry a full line of Aikin, Lambert & Co.'s gold pens, and in connection have a factory with every requirement for gold pen repairs. Joy & Johnson, it is understood, are to retire from business.

George M. Wallace, of R. Wallace & Sons Mfg. Co., reports good business at both the Chicago office and the factory. "Our varied lines," said he, "finds something always moving, but the chief reason must be assigned to 'hustling.' We are doing a World's Fair business right now in April." Mr. Wallace will spend a week the latter part of May at the factory on business, and later in the season will spend a vacation with his family at Madison, Conn.

On twelve pages of heavy bristol board in portfolio form, each page in script letters with gold and black ornamented border, appear the resolutions of the Chicago Jewelers' Association on the death of president Sebastian Andersen, of the Juergens & Andersen Co. The work is a fine example of the bookmaker's art. Following the resolutions are pages containing the auto-

graph signatures of each member of the association. The volume is bound in black seal, 12x16 inches, with neat gold decoration and has an inscription in gold on the front cover:

IN MEMORIAM  
OF  
SEBASTIAN ANDERSEN

Buyers who have added to their stocks from the latest lines shown by Chicago jobbers include: E. Wehmhoff, Burlington, Wis.; F. Wegen, Buffalo, Minn.; R. E. Winter, Fort Sheridan, Ill.; E. F. Winegar, Kenosha, Wis.; Albert Miller, Dundee, Ill.; Smith, Newell & Co., Hebron, Ill.; E. Odell, Hobart, Ind.; P. Peiffer, Lemont, Ill.; C. J. Peterson, St. Charles, Ill.; Dr. H. J. Riesland, Brainerd, Minn.; D. W. Pennell, Baraboo, Wis.; O. S. Clayton & Sons, Aurora, Ill.; C. S. Dustin, Stillman Valley, Ill.; G. W. Dolph, Winamac, Ind.; Woods Denney, Aurora, Ill.; Egermann & Son, Aurora, Ill.; H. Friedman, Des Moines Ia.; Foster & Hammer, Beresford, S. D.; Philo Holderness, Batavia, Ill.; Amana Society, So. Amana, Ia.; D. C. Ackerman, Prairie City, Ill.; Geo. F. Beach, Valparaiso, Ind.; J. W. Burkitt, Arlington Heights, Ill.; A. Brown, Mokena, Ill.; W. P. Yeoman, Waukegan, Ill.; John Pierik, Sommers & Pierik, Springfield, Ill.; O. D. Chapman, Coldwater, Mich.; G. Cæsar, Chipewa Falls, Wis.; A. R. Stanley, Austin, Ill.; Davis & Heller, Brazil, Ind.; A. H. Wagner, Perry City, Ill.; H. C. Thomas, Washington, Ind.; Fred. Eynatten, Peoria, Ill.; Henry Strouse, McGregor, Ia.; H. C. Kachlein, Lafayette, Ind.; Carl Oesterle, Joliet, Ill.; M. Hedman, Table Grove, Ill.; J. F. Ingalls & Son, Waukegan, Ill.; F. C. Johnson, Fayette, Ia.; Emil Keller, So. Chicago, Ill.; M. C. Knudson, Kenosha, Wis.; L. Luchtemeyer, Blue Island, Ill.; Lundgren & Wilson, St. Charles, Ill.; W. J. Sproul, Sparta, Ill.; J. W. Spence, Racine, Wis.; Geo. Van Voorst, Union Hill, Ill.; A. H. Wagner, Prairie City, Ill.; T. H. Webb, Peoria, Ill.

In THE CIRCULAR of the 15th ult., the writer inadvertently stated that the J. M. &



# JUST OUT!

## Our New Illustrated Catalogue of . . . .

Watch Materials, Tools, & Jewelers' Supplies was issued MARCH 20th.



IF you have not already received a copy notify us and we will send you one at once. We wish to emphasize that our Prices will be found the LOWEST, quality of goods considered. With a well selected stock we are enabled to fill all orders promptly and correctly.

### BENJ. ALLEN & CO.,

141-143 STATE STREET, CHICAGO, ILL.

### Watches, Diamonds, Clocks and Jewelry.

WE HAVE REDUCED CHUCK MAKING TO A SCIENCE, OUR CHUCKS ARE ALL TRUE. BUY THE DALE.

— ALL KINDS \$1.00. —



MADE ONLY BY

**HARDINGE BROS.,**

1036 LINCOLN AVE., CHICAGO.

**R. M. JOHNSON,**

IMPORTER OF

Diamonds and Manufacturing Jeweler,

67 WASHINGTON STREET, ROOMS 5 & 6,

CHICAGO.

MASONIC EMBLEMS OF EVERY DESCRIPTION MADE TO ORDER.

## REED & BARTON,

### SILVERSMITHS,

MANUFACTURERS OF

### STERLING SILVER and SILVER PLATED WARE.

SALESROOMS:

### 37 Union Square, New York.

34-36 WASHINGTON STREET,

### Venetian Building, Chicago.

FACTORIES, TAUNTON, MASS.

## DUEBER-HAMPDEN WATCHES.

The most reliable watches are the Hampden 17 Jewel. A full line of Dueber Cases and Hampden Movements. Cash buyers write us.

### BRETHAUER WATCH & JEWELRY COMPANY,

SPECIAL AGENTS,

71 WASHINGTON ST., CHICAGO, ILLS.

### THE PLANCHAMP & BECKER CO.

Makers and Repairers of

### WATCH CASES,

Gold and Silver Plating —

— of Watch Cases a Specialty.

UNEXCELLED FACILITIES.

53 and 65 East Washington St., Chicago.

EST. 1870.



**DR. PETER HENRY,**

SPECIALIST IN

WATCH • CASE • DISEASES

Key Winders & changed to Stem Winders

Hunting Case: changed to O. F

English Cases changed to fit American movements

Can be cured at 53

Longworth St., Cincinnati, Ohio.



WRITE FOR NEW CATALOGUE.

## Chicago Watchmakers' Institute,

SUITE, 913 A MASONIC TEMPLE, Our New and Enlarged Quarters.

A Modern Trade School for the Watchmaker, Jeweler and Engraver.

### ELGIN HOROLOGICAL SCHOOL,

THOROUGHLY PRACTICAL. COMPETENT INSTRUCTORS.

Send for Prospectus.

ELGIN, ILL.

### PARSONS : SCHOOL

— FOR —

### WATCHMAKERS,

PEORIA, ILL.

Send for Circular and Terms.

PARSONS & CO.



A. C. Johnston Optical Co. would remove to the northwest corner of State and Madison Sts. In this he erred. The company have leased for five years suite 912, Masonic Temple, and removed to their new quarters May 1st. On the ninth floor the firm have 38 x 15 feet devoted to offices and salesroom and on the tenth floor have established a factory and shipping room. The new factory has every convenience for promptly handling prescription work and grinding for special orders. This is quite an enlargement of the firm's facilities and they guarantee satisfaction and accuracy in filling orders intrusted to their care.

### Indianapolis.

Jas. N. Mayhew, optician, is repainting and decorating his show window.

Coffelt & Beade, 155 Columbia Ave., are a recent addition to the jewelry trade of this city.

Messrs. Heaton and Sims, of the wholesale firm of Heaton, Sims & Co., will prolong their visit to California until about June 1st.

Will Haseltine, Kokomo, Ind., was a delegate to the State Republican Convention held here last week. Charles Frame, Franklin, Ind., was also in attendance at the convention.

F. M. Herron has been elected a delegate from the Indianapolis Whist Club to the

congress of the American Whist League, to be held in Philadelphia, May 22d to 26th inclusive.

I. C. Crane has so far recovered from the injuries received in an accident several weeks ago that, with the aid of a pair of crutches, he is able to be at his place of business.

Some Indiana dealers in the city last week were: Nutter Bros., Martinsville; C. K. McCain, Kokomo; E. C. Barnes, Princeton; A. C. Pilkenton, Fortville; Woodville & McIlvain, Nineveh; and H. C. Jones, Laurel.

Newton Dexter, secretary of the Business Men's Association of New York State, arrived in the city last week for the purpose of organizing a State association of the jewelers in Indiana. As the result of an accident received in Chicago he has been confined to his room at the Bates House for several days and was thus prevented from meeting the local jewelers.

### A Trio of Spectacle Fakirs Arrested in Saginaw.

DETROIT, Mich., April 27.—Three men, giving their names as Arthur Hudson, George M. Smith, and Thomas P. Keller, and their homes in Detroit, were arrested in Saginaw last week, charged with peddling without a license. They were all well dressed young men, and had a scheme which, although old, worked well. They presented themselves at the door of a resi-

dence with a pair of spectacles, which they claimed were found in the near vicinity, and being "real honest," they had come to see if the resident had lost a pair. The fakir then offered the spectacles for sale, as he had no use for them. A bargain was frequently struck, and an amount several times in excess of the real value of the glasses was obtained.

How often one waits for the alarm clock to run down and then turns over and takes another nap. How often we declare we did not hear the alarm and thereby miss an early appointment. This is rendered impossible by a recent invention of R. Rueping, Chicago, called the Wizard Electric Alarm, which renders sleep impossible until the sleeper is thoroughly aroused and arises to turn off the alarm. A handsome compact cabinet contains a dry battery which is connected with an alarm clock and electric bell. On the front of the cabinet is an electric switchboard for turning the current on or off. The clock is set from the back plate and the current turned on. When the appointed time has arrived the alarm does its work thoroughly. It will also be found useful on the office desk to remind one of appointments. At the low price the alarms are furnished, they should prove popular in both house and office. The alarms are manufactured by the R. Rueping Co., 82 Madison St., Chicago.

## TWO PAIR !!



Two pair beat two of a kind in illustrating the advantages to be derived from dealing with Goldsmith Bros. In March Jewelers Joy and Happy, depicted in the left in the above illustrations, were two of a kind in their opinion of the firm. They agreed that the tests were accurate and valuations correct, and were pleased to get cash remittances on receipt of shipment. This month Jewelers Grumpy and Hardscrabble were overheard discussing their woes.

GRUMPY—No Sir; I'll never do it again.

HARDSCRABBLE, (testily)—Do what?

GRUMPY—Send stuff to Graball & Skinem, those sweep and old gold and silver fellows.

HARDSCRABBLE—Not I.

GRUMPY—So you sent to them, did you? Well, I had been sending to Goldsmith Bros. and was satisfied, but thought I'd change. It was a change all right, but its Goldsmith with me hereafter.

HARDSCRABBLE—Me too; I changed, and wish I hadn't,

And they fell upon each others necks and vowed Goldsmith Bros. gave best returns.

TWO PAIR as an illustration win more to our standard than TWO OF A KIND.

**GOLDSMITH BROS.,**  
**GOLD, SILVER AND PLATINUM REFINERS,**  
 63 and 65 WASHINGTON ST., CHICAGO, ILL.



**Pacific Coast Notes.**

R. McDonald, Tulare, Cal., has advertised the sale of the unclaimed watches.

E. E. Farwell has established himself in the jewelry business in Ellensburg, Wash.

J. A. Winslow, jeweler, Phoenix, Ariz., has removed his stock to Globe, and will open a jewelry and repair store.

Wm. Furber, formerly in the jewelry business in Ukiah, Cal., will leave shortly for Central America, where he will engage in business.

E. L. Dorrett, recently with E. Maybem, Chico, Cal., has secured the position of repairer in J. L. Bennett's jewelry store, Marysville, Cal.

Geo. E. Brown, employed in the wholesale establishment of A. I. Hall & Sons, San Francisco, was married a few days ago to Miss Williams, Alameda, Cal.

The Western Union Telegraph Co. are canvassing California towns to put in electrical self-winding clocks in hotels and business places, to be connected with the Lick Observatory.

C. L. Dresbach, recently established in Petaluma, Cal., is a wheelman as well as a jeweler. Mr. Dresbach rides his wheel to and from San Francisco when he visits the city on business.

A bungling attempt at counterfeiting has just been brought to light by the arrest of the principal in the case. The capture was brought about through Shreve & Company, San Francisco, co-operating with the secret service officers Jas. Barclay, alias C. C. June, of Ione, Cal., has been arrested as the outcome of a letter received by Shreve & Company some two months ago. The letter is as follows:

January 22, 1894.

Geo. C. Shreve & Co., San Francisco.

GENTLEMEN:—I am desirous of obtaining an engraver to engrave a set of dies for me for the purpose of electrotyping from, and now if you are not in the employ of the Government and want to do the job for me please let me know what your charges will be for a five-dollar piece of 1892 or 1893, and your money is ready. If you conclude to do the job for me please let me hear from you soon.

Yours truly,

C. C. JUNE.

P. O. Address: Ione, Amador County.

**PFEIL & OBERNDORF,**  
MANUFACTURING JEWELER.  
Diamond Work a Specialty.

**BEST of Workmen.**  
**BEST Design Work.**  
**GUARANTEED Workmanship**  
Send a trial order and be convinced.  
**182 State St., Chicago.**

**HUGO MUELLER,**  
**182 State St., (Room 70,) Chicago.**

**FINE WATCH REPAIRING**

IN ALL ITS BRANCHES.

Work for the trade promptly executed by skilled workmen.



**OPTICIANS' SCHOOL.**

If you want a GOOD ROOF over your head, come to our school. We want EARNEST STUDENTS, leave the rest to us, we do not want diploma hunters.

The Chicago Ophthalmic College and Hospital,

H. M. MARTIN M. D., PRESIDENT. 607 VAN BUREN ST., CHICAGO  
Being the oldest and most favorably known College of Theoretical and Applied Ophthalmic Optics in America, having more thoroughly qualified opticians in the field than all other so-called schools combined.



The only  
PERFECT  
HARDENED  
GRADUATED  
MANDREL.

MADE ONLY BY

**W. W. OLIVER, - BUFFALO, N. Y.**

..... Send for our No. 10 Catalogue .....

**R. J. MFG. CO.,**  
RACINE, WIS.

**Spectacle Temple Washers.**

Gross in a Bottle, 15 Cents.



OPTICAL and MATERIAL DEALERS.

**Jewelers' Auctioneer.**



**NEVER A FAILURE.**

References from over 300 Wholesale and Retail Jewelers in all parts of the country. Profits Guaranteed. Correspondence Confidential. Write for terms and details.

**501 MASONIC TEMPLE,**  
**CHICAGO.**

... THE ...

**American Horological Institute**

AND TECHNICAL SCHOOL OF LANCASTER, PA.,  
LATE OF PHILADELPHIA, PA.,

A Trade School where Watchmaking is taught practically. We do not manufacture

☼ BICYCLES OR DYNAMOS ☼

at this institute. We confine our work strictly to WATCH WORK and its kindred branches, which include

== Engraving, Jewelry Work and Optics ==

One tuition pays for all the branches. We do not have boy instructors at this institute, all men of years of experience. Each department has its separate instructor. Our institute is open for inspection. We kindly invite you to visit us and inspect our school modes of giving instruction and the progress that our students make by giving them practical instruction.

**THOMAS PENDERGAST,**

PROPRIETOR AND MANAGER.

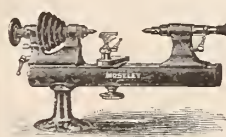

One of the best of the very best.

QUALITY IS THE STANDARD OF VALUE.

CHARGES TO SUIT THE TIMES.

When interested, write your jobber for new price list for 1894, or

Moseley & Co., Elgin, Ill.



No. 2 Moseley Wire Chuck has length, strength, accuracy.



**Cincinnati.**

W. B. Elson, Freeport, Ill., has gone on a trip to Nebraska.

George Bishop has started on the road for the Duhme Co.

John Beck, Washington C. H., O., is in the city this week.

Mr. and Mrs. Chas. Duhme will sail in May for a three months' tour in Europe.

John Larson, Madison, Wis., is on a fishing expedition in the northern part of the State.

D. Jacobs & Co. have dissolved partnership, M. R. Jacobs retiring. The firm will continue at the old stand.

M. Schmidt, of Schmidt Bros., Milwaukee, Wis., was married some days ago, and is making a tour of Ohio cities on his wedding trip.

A. C. Thomas, Washington, Ind., has had a six days' auction clearing out old clocks, and will move into a new store in the Fall, with entirely new goods.

Wm. Pfeuger, the popular traveler of Jos. Noterman & Co., is being congratulated on another boy arrival in his family. His name is Carl, and he is dedicated to the jewelry business.

E. & J. Swigart are out with all the new materials and tools of the advanced age. They are one of the most progressive material houses in the west, and are prepared to give prompt responses to all orders. Send for their crown gauge which they are giving away to their customers. By the aid of this gauge, crowns for cases can be ordered correctly every time.

A report of the large robbery of diamonds from George W. Miller's jewelry store, St. Louis, is followed by the rumor that three

crooks well known in Cincinnati are responsible for the burglary, and have brought the stolen goods here. The three are Billy Fields, Billy Coleman and "Copper" Smith, the latter a native of the West End. All three were caught in the act of cracking a safe in Brownstown, Ind., were sent together to Jeffersonville Penitentiary, and together they recently "crushed" out and escaped. There is, however, little likelihood that they would come here, where they are known to every detective on the force.

**Charge of Fraud Brought Against Peter Bruno.**

HAZLETON, Pa., April 25.—Peter Bruno was arraigned Saturday night on a charge preferred by Prince, Sheriden & Schone, New York, who claimed that Bruno had fraudulently represented his business dealings with the firm. The firm had sold defendant a bill of goods to the amount of about \$318.

At that time Bruno was associated in business with C. Parisio, under the firm name of C. Parisio & Co., although it is since claimed that Bruno's wife was the partner and not he. The firm represented that they were worth about \$2,000, over and above all liabilities, and goods were sold on monthly notes of about \$54 each. The first one or two notes were paid as they became due and the next went to protest. Having been advised of the fact that Parisio & Co. had given up their store, Mr. Prince came on to Hazleton Thursday last to look into things for himself. Being perfectly satisfied that fraud was intended he swore out a warrant against Bruno for procuring goods under false pretenses.

Bruno was, after an examination, held by Squire Gorman for the Grand Jury under

\$1,000 bail. While the investigation was in progress Mr. Prince secured the services of constable James F. Boyle, who located a quantity of the goods which, as is charged, were secretly removed some time before from the store occupied by Parisio & Co., and levied upon them in the interests of the creditors.

For some time back Bruno and Parisio had been quarreling in regard to business matters and on Thursday last Bruno had Parisio arrested on a charge of embezzlement, but Parisio was discharged.

**Springfield, Mass.**

Mr. and Mrs. O. W. Bullock returned Friday from a four months' visit to California and the west. Both are much improved in health.

R. F. Wilkinson, for Nelson H. Brown; William H. Jones, of Larter, Elcox & Co.; and Mr. McCarter, of the Gorham Mfg. Co., were among last week's visitors here.

Miss Hannah Madsen, sister of jeweler Martinus Madsen, who has been living in Demorest, Ga., for some time, has returned north and will make her home with her brother in South Hadley Falls.

APPRECIATIVE.

A young man, fresh from college, wore as a scarf pin, a jeweled gold potato-bug. One day he called the attention of an old German bookseller to it, asking: "Isn't that pretty, Dutchy?"

"Ja, ja," was the reply, "dot ish der piggest pug on der schmalest botato I haf efer seen."

It seems natural that installment dealers should sell clocks on time.—Philadelphia Record.

**E. & J. SWIGART,**

No. 101 West Fifth St., Cincinnati, O.

JOBBER OF

Jewelers' Tools and Materials.

AGENTS FOR

**KAGY'S**  
**HARD SOLDERING COMPOUND.**

FOR SALE BY

**ALL JOBBERS.**

Price per Box, - 25 Cents.

DIRECTIONS INSIDE.

Send for Sample Package.

We make a specialty of filling Orders for small pieces PROMPT and CORRECT.

Send for Illustrated Catalogue with latest reduction in prices.

Hard Soldering Made Easy.

No Boiling, No Acid, No Pickle Needed.

**BOLSTAD MFG. AND PLATING CO.,**

(H. E. BOLSTAD, PRES.)

WATCH CASE MAKERS, REPAIRERS, PLATERS. PLATED INLAYING ON CASES.

BEST WORK. BEST WORKMEN.

170 MADISON ST., - CHICAGO.

**Wake Up Your Customers**

WIZARD ELECTRIC ALARM

SIZE, 7 X 7 1/2 X 3.

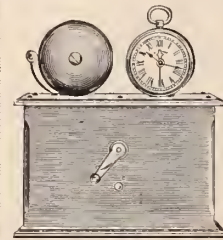

RINGS UNTIL SHUT OFF

With the new Wizard Electric Alarm Clock.

Neat, reliable compact, lowest priced and best Electric Alarm Clock on the market.

Special Offer.

We will give you the exclusive agency in your city (if not over 20,000) if you are the first to send in an order, and as long as you sell the clocks the agency will be yours. The cabinets are made of Oak, Cherry and Walnut, Price, \$3.00 net with first order, special discount in dozen lots.

**R. RUEPING CO.,**

82 MADISON STREET, CHICAGO.



**Minneapolis and St. Paul.**

C. A. Olson, Minneapolis, is on the sick list.

L. D. Fabrick has started in the jewelry business at 507 Washington Ave. S., Minneapolis.

The assignee sale of the Jesse Collom stock commenced Wednesday, April 25th, at 10 A. M., and continues every day until all sold.

Sischo & Beard, St. Paul, who recently removed from the Endicott building into the Manhattan building, are now comfortably settled.

The case of assault and battery recently brought against W. M. Stone, Minneapolis, was dismissed in the Municipal Court last week, as there was no cause of action.

John A. Vlasek, Minneapolis, the past week, removed his place of business from 22 1st St. N., where he has been located for the past 12 years, to a more central location at 203 Washington Ave.

Eastern jobbers and manufacturers represented in the Twin Cities the past week were: Benj. Allen & Co. by Charles Trout; Simpson, Hall, Miller & Co. by W. F. Adams; Sussfeld, Lorsch & Co. by C. O. E. Hartung; Waterbury Clock Co. by Fred L. Pettet.

The following is a list of the Minneapolis jobbing houses that will close their places of business at 1 o'clock P. M. Saturday during the Summer months: Reed & de Mars Jewelry Mfg. Co.; S. H. Clausin & Co.; H. E. Murdock; Spaulding Bros.; Minneapolis Jewelry Mfg. Co.; W. L. Pettitt & Co.; Rentz Bros., and the L. D. de Mars Jewelry Mfg. Co.

Benjamin & Co., Minneapolis, who were wrongly reported to have assigned, very suddenly closed their place of business, packed up their stock and fixtures and stored them. Owing to dull trade and big expenses the firm were obliged to discontinue business. They owe about \$1,500 and propose to settle all claims against them satisfactorily. They will not resume.

**Detroit.**

R. J. F. Roehm has returned from a two weeks' trip to New York.

E. Petz & Co., 22 Monroe Ave., are making extensive alterations and improvements in their store.

The suit brought by Walter G. Hogan against F. G. Smith, Sons & Co., was continued last week in the Circuit Court.

R. Kern, manufacturing jeweler, has taken his brother into partnership with him and the firm now reads Kern Bros.

William Bellows, formerly a jeweler in Seneca Falls, N. Y., will shortly open a repair shop in the store of Kern Bros., 171 Griswold St.

Burglars recently entered the store of R. N. Willson at Galesburg, and stole \$150

worth of watches and jewelry. The burglars cut a panel out of the rear door.

The auction jewelry sale, which was held recently by Wolf & Co., at 41 Michigan Ave., has been finished. G. W. Lusk and H. F. McConnell, auctioneers, of Chicago, have returned to that city.

Wm. Ulrich, jeweler, 322 Gratiot Ave., has filed a chattel mortgage for \$1,098.43, in favor of Eugene Deimel, jobber. The mortgage runs for six months and covers the entire stock, fixtures and book accounts. Mr. Ulrich will continue the business for the present.

Geo. Johnson, West Branch, Mich., was here last week purchasing goods. He recently purchased the stock and fixtures of A. C. Neilson, of that place, and will continue the business. Mr. Neilson contemplates moving to Chicago and starting in the business again.

Business assumed a somewhat brighter hue last week. The retail trade noticed an increased demand for the latest novelties in silver. Mail orders were better with the jobbing trade. The following country jewelers were in the city last week: J. P. Haep, Montpelier, O.; Wm. Gribben, Carsonville, Mich.; T. W. Pelt, Bellville,

Mich.; C. C. Younglove, Newberry, Mich.; A. W. Kludt, Lennox, Mich., and George Johnson, West Branch, Mich.

**Watch Inspection on the Chesapeake & Ohio Railroad.**

CHICAGO, Ill., April 28.—In the report of the inspection of watches on the Chesapeake & Ohio Railway for the past quarter year, J. W. Forsinger, general inspector, states that the employes of the road are complying with the weekly comparison order with almost no exceptions, and congratulates the general manager of the road on the following good showing: Watches inspected, 713; watches compared with standard time weekly, 582; average number of days run for rated watches, 20; average daily variation, in seconds, for rated watches, .7.

These results have gradually been brought about by the careful work of the following inspectors: J. T. Allen & Co., Richmond, Va.; J. W. Lipop, Clifton Forge, Va.; Keller & George, Charlottesville, Va.; W. L. Fredeking & Co., Hinton, W. Va.; Glen Hilton, Huntington, W. Va.; F. Piepers, Covington, Ky.; Wm. Owen, Cincinnati, O.; J. Jones, Lexington, Ky.; I. N. Pollack, Ashland, Ky.

**REMOVAL, May 1, to the Masonic Temple, Chicago.**



OUR NEW FOUR-FOOT EYE GLASS. In our new and enlarged quarters in the Masonic Temple, Room 912 we shall be able, with the larger stock, which we shall carry there and new machinery now being installed, to fill stock or repair orders or prescriptions quicker and even better than before.

**AUTOMATIC SOUP SPOON** IMPOSSIBLE FOR SOUP TO TOUCH THE MOUSTACHE

**SOLID COMFORT WRITE FOR ILLUSTRATED BOOK**

ALSO FOR CONDITIONS & CONTRACT FOR EXCLUSIVE SALE IN YOUR CITY

**QUENTELL AUTOMATIC SPOON CO.**

49 WEST 3<sup>rd</sup> ST. CINCINNATI, OHIO.



**GIBSON HOUSE,**

CINCINNATI, OHIO.

ABSOLUTELY FIRST-CLASS AMERICAN PLAN HOTEL.

\$3.00 PER DAY.

Extra Charge for Parlors and Rooms with Bath attached. The unequalled advantages in central location, liberal management, modern appointments, experienced service and perfect cuisine, have permanently established the Gibson House as The Most Popular First-Class Hotel in Cincinnati.

AMPLE VAULTS FOR THE PROTECTION OF VALUABLES.

**THE GIBSON HOUSE CO.,**

H. B. DUNBAR

President and Manager.



### Connecticut.

H. R. Wilson, Stamford, has just opened a jewelry and repair store in Fairfield.

T. H. Brown, Meriden, is so far improved that his recovery from his illness, which was at one time of a critical nature, is assured.

The employes of the Seth Thomas Clock Co.'s works, Thomaston, have been notified that the factory will be run on full time, commencing Thursday last.

C. H. Tibbitts, as one of the executors of the late Samuel Simpson's estate, Wallingford, has been placed in charge of the management of the estate, the collecting of rentals, etc.

W. W. Myatt, of the Meriden Britannia Co., arrived home after a business trip through the west, reports business as somewhat interfered with by the extensive strikes in progress.

Business is better among the factories of Wallingford. Maltby, Stevens & Curtiss Co.'s factory ran last week 54 hours. Wallace's in many departments have all they can do. The outlook is encouraging.

Mr. Biggins will immediately assume the control and management of his new company's plant. The factory building is completed and ready to receive the machin-

ery, which has been purchased from the Hartford Silver Plate Co.

A. W. Strauss, of Strauss & Macomber, New London, arrived home Saturday, April 28th, from Old Point Comfort, where he has been for some time on account of his health. After a short stop in New London he will go on to his home in Boston.

President J. D. Bergen, of the J. D. Bergen Co., Meriden, and his brother, C. B. Bergen, and the latter's wife, sailed Friday on the Allan line steamer *State of Nebraska* for Liverpool. They will be abroad about two months.

Ryder, Bryant & Co., Danbury, have just issued a dainty souvenir spoon. It is of solid silver and etched upon the handle is an excellent likeness of the late J. M. Bailey, famous as the *Danbury News* man, author and humorist. In the bowl of the spoon is a picture of the *Danbury News* building.

Henry Maillard is home in Waterbury from St. Louis, Mo., where he has been for some time with the famous Century clock belonging to the Waterbury Watch Co. Mr. Maillard was assistant to the electrician who had charge of the clock at the World's Fair, and after the Fair he went to St. Louis with the clock.

Attorney David Strouse, of New Haven,

has been appointed in the probate court trustee for the insolvent estate of the Manhattan Watch & Jewelry Co., of that city. The liabilities of the concern are \$16,350, with assets of \$5,000. The largest creditor is the Rockford Watch Co., whose claim is \$6,377.

George R. Streeter, for 25 years a prominent New Haven jeweler, and who has been proprietor of a jewelry store in Fredericksburg, Va., for the last three years, has closed his store in Fredericksburg and concentrated his business at E. Orange, N. J., where he started in the jewelry business a few months ago. He sold out at auction a large part of the goods in his Fredericksburg store.

The New Haven Clock Co. are having very busy times in the production of their new specialty, the "Infanta" watch, called "Fad," for brevity, a very low-price pocket watch, made both with silver and nickel-plated or gold plated case. The demand for them is great, and about 100 hands are engaged 10 to 12 hours a day on this branch of the work, at the big factory. Work in the other departments is quite brisk.

The Standard Electric Time Co., New Haven, have decided not to remove the time plants in Ansonia, Derby and Shelton, but to rebuild them throughout with copper metallic circuits. The central station apparatus will be built over and the latest improvements adopted up to date, which will make the service as good as it has been at any time. The Waterbury plant is also to be rebuilt and quite a number more clocks added.

The funeral of the late Elbert B. Monroe, whose death was reported in THE CIRCULAR last week, which took place from the Southport Congregational church Wednesday, was the largest held in that village. A delegation was present from the New York Stock Exchange. Cornelius Vanderbilt, of New York, was one of the honorary pall bearers, as was also William E. Day, J. H. Day and several others from New York city. The remains were interred in the Marquand plot in Oak Lawn cemetery.

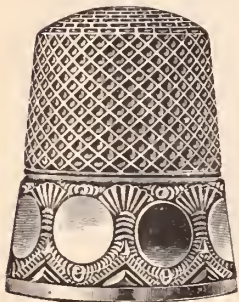

**KETCHAM & McDOUGAL**  
MANUFACTURERS  
GOLD & SILVER THIMBLES,  
GOLD COLLAR BUTTONS,  
AUTOMATIC EYE-GLASS HOLDERS  
198 BROADWAY N Y

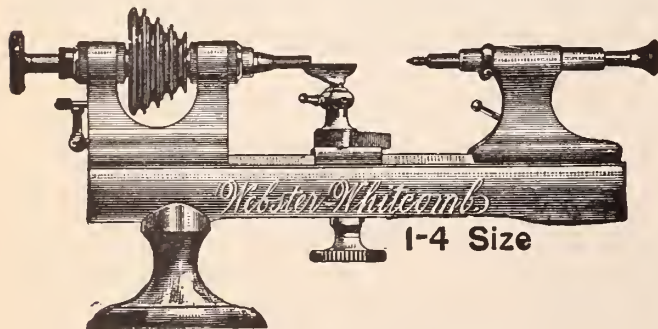
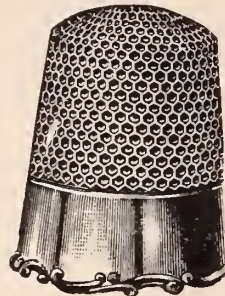

**STRONGEST GUARANTEES.**

**Quality  
Maintained.  
Prices to  
Suit the Times.**

Ask for our New  
Prices and  
Terms for 1894.

**American Watch Tool Company,**  
Chymistry Dist., Waltham, Mass., Stoney Batter Works.

### Death of an Old Connecticut Manufacturer.

NEWFIELD, Conn., April 27.—George W. Bacon, a highly esteemed citizen of Newfield, died on April 24th. He was 81 years of age. Born in Newfield, he moved to Meriden when a young man, spending the prime of his life in that city and Wallingford, where he was engaged in the britannia business. He has resided in Newfield about 15 years. He leaves a widow, a son and a daughter.

Mr. Bacon learned his trade in the same room with the late Isaac C. Lewis and the late Samuel Simpson. When these two men went into business for themselves, Mr. Bacon was asked to join them. He, however, became the foreman of Mix's large factories at that time, and became a leader in the knowledge of the pewter making business. Britannia was little used in those days.



**Queries by Circular Readers.**

*Editor of THE JEWELERS' CIRCULAR:*

I think it was in THE CIRCULAR some time ago I saw advertised the small wooden clocks with one hand and run by a weight, with date 1492 on the front. If you would please give me the address of the firm you will greatly oblige  
G. V. CAPRON.

ANSWER:—The articles you refer to are known as the "Columbus Clox." They are made by the Bostwick & Burgess Mfg. Co., Norwalk, Ohio. They retail for about \$1.

*Editor of THE JEWELERS' CIRCULAR:*

Kindly inform me in next issue how to take nicks and grooves out of a large Craigleith stone wheel. Have tried to turn it down with steel and flint, but with poor success.  
H. RUTH.

ANSWER:—Alas, Mr. Ruth, years ago, some one made the remark "there is no royal road to learning," nor will you find a royal, presto change road to get the nicks and grooves out of your stone wheel, except by "main strength and awkwardness," lubricated with elbow grease. The only auxiliary you might apply would be to take it to some machine shop, connect the crank with a belt, and then "if you don't at once succeed, try, try again."

*Editor of THE JEWELERS' CIRCULAR:*

What are the verses that give the meaning of birth-day stones? I remember reading them in THE JEWELER'S CIRCULAR, but I have evidently lost the copy of the paper containing them.

JOHN HUMPHREYS.

ANSWER:—THE CIRCULAR has published these verses at least on one occasion, and has often referred correspondents to the number containing them. For the sake of John we will publish them again. Here they are:

**JANUARY.**

By her who in this month is born  
No gems save Garnets should be worn;  
They will insure her constancy,  
True friendship and fidelity.

**FEBRUARY.**

The February-born will find  
Sincerity and peace of mind,  
Freedom from passion and from care,  
If they the Amethyst will wear.

**MARCH.**

Who in this world of ours their eyes  
In March first open shall be wise;  
In days of peril firm and brave,  
And wear a Hyacinth to their grave.

**APRIL.**

She who from April dates her years,  
Diamonds should wear, lest bitter tears  
For vain repentance flow; this stone  
Emblem of innocence is known.

**MAY.**

Who first beholds the light of day  
In Spring's sweet flowery month of May,  
And wears an Emerald all her life,  
Shall be a loved and happy wife.

**JUNE.**

Who comes with Summer to this earth,  
And owes to June her day of birth,  
With ring of Pearl upon her hand  
Can health, wealth and long life command.

**JULY.**

The glowing Ruby should adorn,  
Those who in warm July are born;  
Then will they be exempt and free  
From love's doubt and anxiety.

**AUGUST.**

Wear Moonstone, or for thee  
No congenial felicity.  
The August-born without this stone,  
'Tis said must live unloved and lone.

**SEPTEMBER.**

A maiden born when Autumn leaves  
Are rustling in September's breeze,  
A Sapphire on her hand should find,  
'Twill cure diseases of the mind.

**OCTOBER.**

October's child is born for woe,  
And life's vicissitudes must know;  
But lay an opal on her breast,  
And hope will lull those woes to rest.

**NOVEMBER.**

Who first comes to this world below  
With drear November's fog and snow,  
Should prize the Topaz' amber hue—  
Emblem of friends and lovers true.

**DECEMBER.**

If cold December gave you birth,  
The month of snow and ice and mirth,  
Place on your hand a Turquoise blue,  
Success will bless whate'er you do.

If you have not yet received the catalogue of tools and materials issued by Benj. Allen & Co., Chicago, your first duty is to write for it. As a compendium of everything required by the watchmaker and jeweler it is the most complete work ever issued, and covering, as it does, the latest revised prices of leading manufactures and the lowest prices consistent with best quality of all standard tools and materials, the volume is at this time doubly welcome. Every practical tool manufactured up to the present time is represented in its pages, and 223 of its 464 pages are finely illustrated with materials accompanied by reading matter fully descriptive of each article. It is the most useful book to-day before the watch-making public and will be sent free on request.

Leonard Brilleman, only son of ex-Alderman Isaac Brilleman, the well known jeweler of Albany, N. Y., died April 24 at the home of his parents. Deceased was 22 years of age, a favorite in social, religious and business circles, and had developed exceptional talents in mercantile life.

HAVE REMOVED OUR NEW YORK OFFICE TO

4 Maiden Lane.

SILVER

Deposit Cologne.

PURE SILVER <sup>1.000</sup>/<sub>1.000</sub> FINE.



No. 223.

ALVIN MFG. CO.,  
WORKS, - IRVINGTON, N. J.

**REMOVAL OF**  
**American Morocco Case Co.**  
**TO 38 E. 19th ST., N. Y.**

**OUR SPECIALTIES**

WILL CONTINUE TO BE

- { FINE SILVERWARE CASES COVERED WITH SILKS, LEATHER AND OTHER FABRICS
- { FINE CASES FOR JEWELRY AND WATCHES.
- { FINE HARD WOOD TRUNKS WITH ONE OR MORE DRAWERS
- { SHOW CASE TRAYS IN ALL GRADES.



**DIAMONDS.****Wm. S. Hedges & Co.,**

Importers of Diamonds,

And Manufacturers of DIAMOND JEWELRY.

170 Broadway, New York.

22 Holborn Viaduct, London.

**R. A. KIPLING,**

Importer of

**PRECIOUS STONES,**

21 &amp; 23 Maiden Lane,

19, RUE DROUOT,  
PARIS.

New York.

**NOTICE !****TO MANUFACTURERS**

A WELL-KNOWN Manufacturing House  
visiting the best retail Jewelry trade  
throughout the country, wishes to make  
arrangements with manufacturer of nov-  
elties in Gold Jewelry, to carry in con-  
nection with their line.

Address K.,

Care of Jeweler's Circular.

**Alfred H. Smith & Co.,**IMPORTERS**DIAMONDS**

AND

**PRECIOUS STONES,**

182 BROADWAY, COR. JOHN STREET

NEW YORK.

35 Holborn Viaduct, London, E. C.

**STERN BROS. & CO.,**

CUTTERS OF

**DIAMONDS,**

WORKS:

29 &amp; 31 Gold Street,

33 to 43 Gold Street,  
NEW YORK.

OFFICE,

30 MAIDEN LANE,

NEW YORK.

**Rice & Hochster**  
Manufacturers of  
**TORTOISE**  **SHELL**  
**GOODS**  
485 BROADWAY, NEW YORK.

**Trade Gossip.**

Notwithstanding the dull times F. Fuchs & Bro., New York, are actively producing many new designs in solid silver ware. They have just put on the market a large line of scissors of many sizes and patterns. Dealers in silverware should give this firm a call.

One of the most artistic cards of the season has been issued to the trade by Leroy W. Fairchild & Co., makers of gold pens and novelties, Third Ave. and Ogden St., Newark, N. J. The card announces the removal of their New York office from 189 Broadway to the Stevens building, 3 Maiden Lane.

Ernest Campbell, of the Campbell-Metcalf Silver Co., Providence, R. I., who designed the official souvenir spoon of the California Mid-Winter Exposition, also designed the souvenir spoon of the Providence Kirmess, which was made by the Campbell-Metcalf Co. At the top is a dancing girl in graceful position and proper costume. The figure is surrounded with flowers, and beneath are the words Providence Kirmess, and an ornamental design extending to the bowl. The effect is enhanced by enameling. The design was selected by the Tilden-Thurber Co.

One of the most unique articles in household economy is the "busybody" or window mirror, as it is variously called. It is placed in the house window of the story above the street floor and enables an observer in the house to see who is coming up or going down the street or who is at the door, without himself or herself being seen. Its use in Philadelphia, the only place where it has been introduced, is already large and rapidly growing. An agency in any city would be profitable. A cut of the article is shown in the advertisement of Queen & Co., Philadelphia, Pa., in another column.

A circular issued to the trade by Foster & Bailey, the makers of the well-known American F. & B. goods, 100 Richmond St., Providence, R. I., contains a list of the different lines they manufacture. They claim that 20 years' experience in the manufacture of gold and plated jewelry enables them to furnish to the wholesale trade such goods as can be handled profitably. Their plated goods are all made of heavy rolled gold plate, which is guaranteed to wear with perfect satisfaction. They make quite a line of sterling silver bracelets and sleeve buttons, and will also have other sterling goods in their season. They are now making a line of solid gold lockets at a price that will enable the wholesale dealer to handle them extensively.

Rubenstein Bros., of New York, will open up their branch store in the room now occupied by Goldenberg Bros. & Co., Williamsport, Pa., about May 1st. J. W. Mussina, Jr., will be connected with the branch store.



**Fashions in Jewelry and Silver-ware.**

A LADY'S RAMBLES AMONG THE JEWELERS.

Diamond serpents, tails up, are used as chatelaine pins.

Silver combined with enamel is to be the Summer jewelry.

A diamond comet mounted on a tortoise shell spear is a new design.

Enameled hens and roosters, parrots and such on gold bars are used for chatelaine pins.

The new asparagus dishes have pierced bottoms that allow the water to drain into a receptacle beneath.

An interesting chatelaine pin seen was a gold bar passing through a half mask of green enamel with diamond eyes.

The combination of silver and opalescent glass in lamps is effectively made. The lamp shades are of glass overlaid with designs in silver wire.

There is a great showing now of ginger ale supports, flasks, drinking cups, shakers, siphons, wine coolers, and all the paraphernalia that goes toward the making of cooling beverages.

Jewelers abroad make velvet bows, on which they attach some jeweled ornament such as convolvulus leaves. These are intended for the hair, but the ornament may be detached and worn elsewhere.

Sporting brooches are evidently in demand among women of sporting taste. In these is everything from a beautifully modeled race horse to an impudent fox terrier or dandy poodle. These are in diamonds and enamel.

It is a distinction for Palmer Cox that his Brownie books have brought out Brownie pins. These are imitations of the various small people, in colored enamels, and evidently will have a fine show with the nursery people.

The library sets complete are the most attractive things in the market. A large white pad heavily bound at the sides in silver ornamentation was set forth with everything in silver that could possibly tempt to correspondence.

The introduction of silver goods into the shops must encourage a much larger use of silver articles. They will scarcely injure the regular depots for such goods in higher priced articles. The real danger is that they will accustom people to cheap wares, and render them satisfied with such.

For the library table is a new arrangement for sealing letters. It looks like a letter weighing machine, but on one side is an alcohol lamp, on the other supports. Between these is a hollow receptacle for pens and stamps. Lying on the supports and over the lamp is a little silver dipper with an ivory handle. In the dipper a bit of wax is dropped and melted. This is poured out onto the letter or package, instead of using the burning stick in the old fashioned way.

ELSIE BEE.

ESTABLISHED 50 YEARS.

**RANDEL, BAREMORE & BILLINGS,**

IMPORTERS OF

**DIAMONDS,**

AND OTHER PRECIOUS STONES.

**FINE PEARLS A SPECIALTY.**

MANUFACTURERS OF

**DIAMOND JEWELRY,**

IN THE LATEST DESIGNS.

Diamonds Recut in Modern Styles or Repaired on Premises.

58 Nassau Street,  
29 Maiden Lane  
NEW YORK.

1 Tulp Straat,  
AMSTERDAM.

1 St. Andrews St.,  
Holborn Circus,  
LONDON, E. C.



TRADE MARK.

ESTABLISHED 1841.

**CARTER, SLOAN & CO.,**

**MANUFACTURERS OF GOLD JEWELRY,**

No 15 MAIDEN LANE.

NEW YORK.

A. CARTER, JR.  
A. K. SLOAN.  
C. E. HASTINGS.

GEO. R. HOWE  
WM. T. CARTER.  
WM. T. GOUGH

FACTORY, NEWARK, N. J.



**JOHN N. DISSELKOEN,**  
Cutter and Importer of  
**DIAMONDS**  
FACTORY,  
76 LANGBLEEKERSPAD  
AMSTERDAM  
19 East 16th St.,  
NEW YORK.

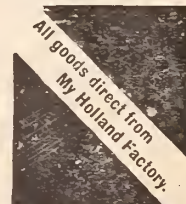







**The DIAMOND EXCHANGE**  
 14 MAIDEN LANE -  
 New York.

**CHAS. F. WOOD & CO.,**  
 IMPORTERS OF  
**DIAMONDS.**

**W. & S. Blackinton,**  
 ...OLD RELIABLE...  
**W. & S. B. ★ Plated Chains.**  
 N. Y., 14 Maiden Lane. Factory, Attleboro, Mass.  
 Have you seen our New Goods?

**C. COTTIER & SON,**  
 ... Importers of ...  
**DIAMONDS.**  
 FANCY GEMS.

**S. LINDENBORN,**  
 IMPORTER OF  
**DIAMONDS.**

**CHAS. H. PECKHAM & CO.,**  
 IMPORTERS OF  
**DIAMONDS & PRECIOUS STONES.**  
 MAKERS OF DIAMOND JEWELRY.  
 PARIS OFFICE, 4 Rue Grenier St. Lazare.

**WM. A. KIDDIE,**  
**DIAMONDS, WATCHES, JEWELRY.**  
 Read the Renaissance of Maiden Lane,  
 Page 30.

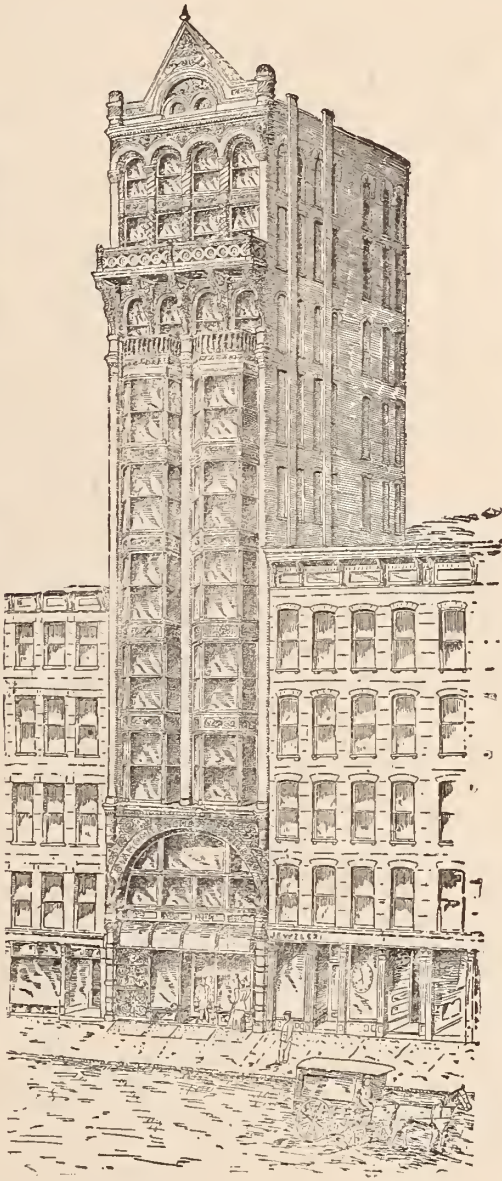

**JULIUS KING OPTICAL Co.,**  
 WILL OCCUPY THE  
**STORE and BASEMENT**  
 AFTER MAY 1st.



# The Renaissance of Maiden Lane

INTERESTING CHANGES IN THE LANE AND ITS ENVIRONS.

PART II,

**T**HE Diamond Exchange, 14 Maiden Lane, is the subject of our illustration. It is 11 stories high with dome, and 25 x 70 feet. Romanesque in style, of granite limestone, iron, brick and terra cotta, the building is attractive and artistic. It is equipped with all modern conveniences and a novel feature is the employment of plate glass for partition purposes instead of lath and plaster.

THE DIAMOND EXCHANGE.

In a handsome, well lighted front office on the sixth floor is the office of Allen & Jonassohn, importers of diamonds and precious and imitation stones. The firm carry a very full line of imitation goods, and in real make a specialty of goods suitable for manufacturers' use. A special drive is being made by them just at present on opals, which are offered in all known shapes at remarkably low prices. The Providence office of Allen & Jonassohn, in charge of F. W. Nichols, is at Dorrance and Pine Sts., where they succeeded to the business of R. A. Kipling. John F. Allen and W. M. Lane look after customers' wants here, while O. T. Jonassohn, at the Paris office, 46 Rue de Turbigo, takes advantage of the best offerings of the European markets.

Among the tenants in this building in handsome offices on the second floor are W. & S. Blackinton, of Attleboro, Mass., whose

Old Reliable W. & S. B. ★ chains have a world-wide reputation. The line now shown comprises, among other things, some very handsome ladies' Victorias in very light weight chains, with charms to match. There are also some new neck chains, with and without pendants, in new and dainty styles of chains.

Charles F. Wood & Co., diamond importers, are on the sixth floor. It needs an inspection of the firm's stock to do it justice. Diamonds and precious stones must be seen to be appreciated.

Chas. H. Peckham & Co., importers of diamonds and precious stones and makers of diamond jewelry, are on the seventh floor.

C. Cottier & Son, importers of diamonds and fancy gems, are on the seventh floor.

On the ground floor and basement are the Julius King Optical Co. In their new quarters, with more room and better facilities, the company propose to do more business than ever.

Rubenstein Bros., with a full line of diamonds, watches and jewelry, are on the ninth floor, while S. Lindborn, diamond importer, will be found comfortably located on the fourth floor.

The Stevens building, 3 Maiden Lane, is eight stories in height, and especially designed for the jewelry and kindred trades. Windows are large with sashes placed well out to avoid reflected light. Each floor has six large windows fronting on the Lane, with north light on all floors above the third. The building is absolutely fireproof, and equipped with all modern conveniences. On the ground floor is E. A. Thrall, who occupied similar quarters in the old building which was torn down to make room for the present structure. Mr. Thrall's stock of watches, diamonds and jewelry will well repay inspection.

The new offices of J. B. Bowden & Co. in the Stevens building are among the most luxurious and comfortable quarters to be found in the vicinity of Maiden Lane. They occupy the entire second floor of the building and have six windows fronting on

the Lane. This firm, who are among the largest and best known manufacturers of rings in the country, have now double their former office space and have been enabled to enlarge each department as well as their private offices and salesroom, thus adding to the comforts of their visiting customers and employes. Among the tenants on the floors above are Quinche & Banks, watchmakers; The Ladd Watch Case Co.'s New York office; Downing, Keller & Co., manufacturing jewelers; Battin & Co., with a beautiful line of silver novelties; Leroy W. Fairchild & Co., gold pens, pen and pencil cases; and Wickliffe B. Durand, precious stones.

Among the many safes which have been seen on the Lane and its environs during the past week, those of Mosler, Bahman & Co., 518 Broadway, N. Y., were conspicuous by reason of their handsome and massive appearance. This firm make a specialty of jewelers' safes, and a card addressed to Manager Caro, at the address above, will bring to your office as handsome an assortment of photographs of safes as can be seen in a day's journey. Should you want any special pattern, the firm will be pleased to make it.

(To be continued.)

ESTABLISHED 1870.



TRADE MARK.

**SAMUEL C. JACKSON,**

MANUFACTURER OF

**FINE CASES FOR**

**Jewelry, Silverware, &c., also Hardwood Chests, Trays, and Sample Cases.**

**180 BROADWAY,  
NEW YORK.**



# STEVENS BUILDING,

3 MAIDEN LANE, NEW YORK.

## QUINCHE & BANKS, WATCH MAKERS.

Repairing of every Description. Watch Glasses  
Fitted.

◁MOVEMENT FITTING A SPECIALTY.▷

DOWNING, KELLER & CO.,  
MANUFACTURING JEWELERS.

BATTIN & CO.,  
SILVER NOVELTIES.

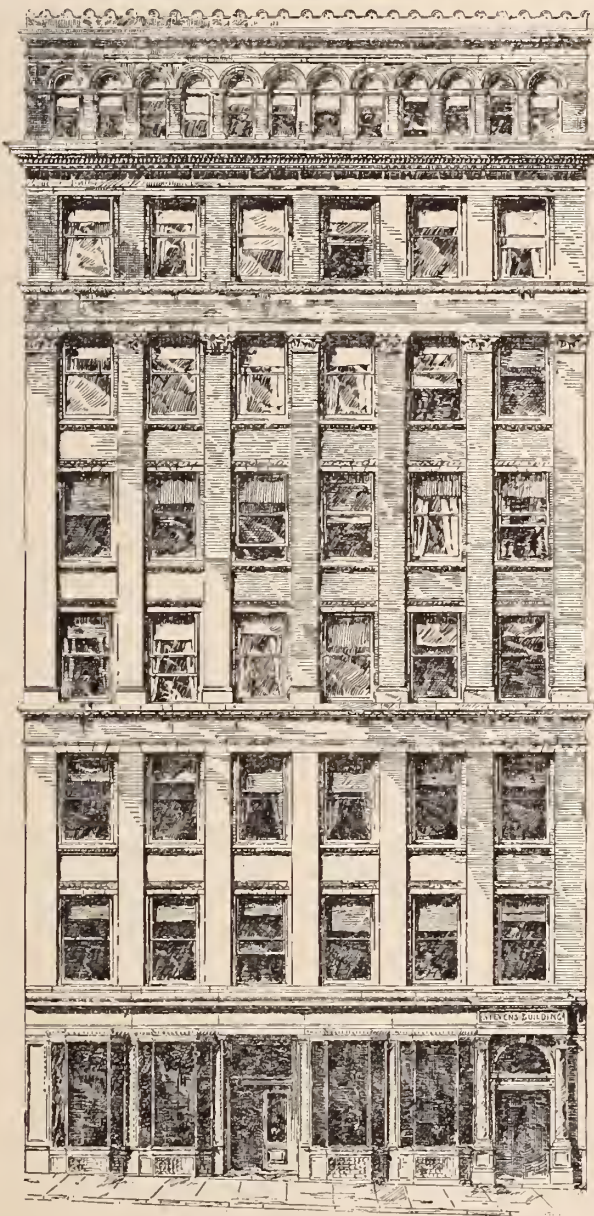

LADD WATCH CASE CO.,

... MAKERS OF ...

14k GOLD STIFFENED CASES.

Factory: Providence, R. I.

LEROY W. FAIRCHILD & Co.

GOLD PENS,  
PEN and PENCIL CASES,  
NOVELTIES,  
CHARMS, Etc.

WICKLIFFE B. DURAND.

PRECIOUS STONES.

J. B. BOWDEN & CO.

RING MAKERS.

EDWIN A. THRALL, DIAMONDS, WATCHES and JEWELRY,  
NOW OCCUPIES THE STORE AND BASEMENT.



# CLASSIFIED INDEX TO ADVERTISEMENTS.

All Advertisements are entitled to one insertion under proper heading. Extra insertions, \$6.00 per annum.  
Extra Headings, \$12.00 per annum.

Page.	Page.	Page.
<b>Alarm Clocks.</b>	<b>Horological Schools.</b>	<b>Silver Plated Ware.</b>
R. Ruebling & Co., 82 Madison St., Chicago, Ills..... 22	American Horological Institute, Lancaster, Pa. 21	Pairpoint Mfg. Co., New Bedford, Mass..... 5
<b>Art Pottery, Bric-a-brac, Etc.</b>	Chicago Watchmakers' Institute, Chicago, Ill. 19	<b>Sterling Silver Novelties.</b>
Bing, Ferdinand & Co., 106 Grand St., N. Y. 38	Elgin Horological School, Elgin, Ill..... 19	Bachrach & Freedman, 1 & 3 Union Sq., N. Y. 7
Hinrichs & Co., 29 & 31 Park Place, N. Y. 43	Parson's School for Watchmakers, Peoria, Ill. 19	Codding Bros. & Heilborn, North Attleboro Mass..... 43
Straus, L. & Sons, 42 to 48 Warren St., N. Y. 37	Philadelphia College of Horology, 623 Heed Building, Phila., Pa..... 42	Hagan, White & Co., 243 W. 23d St., N. Y. 11
<b>Assayers &amp; Refiners.</b>	<b>Hotels.</b>	Quentell Automatic Spoon Co., 49 West 3d St., Cincinnati, O..... 23
Baker, Geo. M., Providence, R. I. 37	Gibson House, Cincinnati, O. 23	<b>Sterling Silverware.</b>
Clark, J. L., Philadelphia, Pa..... 34	<b>Jewelers' Tools, Materials, Etc.</b>	Alvin Mfg. Co., 4 Maiden Lane, N. Y. 25
Goldsmith Bros., 63 & 65 Washington St., Chicago, Ill..... 20	Swigart, E. & J., 101 W. 5th St., Cincinnati, Ohio..... 22	Campbell-Metcalf Silver Co., Providence, R. I. 2
Le Long, L. & Bro., Newark, N. J. 44	<b>Jewelry, Silverware and Optical Cases.</b>	Fuchs, Fred & Bros., 808-810 Greenwich St., N. Y. 43
Rathbone, J., Providence, R. I. 37	American Morocco Case Co., 38 E. 19th St. 25	Howard Sterling Co., Providence, R. I. 9
Schawel, J. & Co., 29 John St., N. Y. 44	Hebbard & Bro., 860 Broadway, N. Y. 40	Reed & Barton, 37 Union Square, N. Y. 19
<b>Auctioneers.</b>	Jackson, S. C., 180 Broadway, N. Y. 30	Schiebler, G. W. & Co., 179 Broadway, N. Y. 43
American Syndicate of Jewelers' Auctioneers, New York and Washington..... 2	Valfer, S. & Co., 48-50 Maiden Lane, N. Y. 28	Towle Mfg. Co., Newburyport, Mass. 37
French, J. H., P. O. Box 2775, N. Y. 7	<b>Jewelers' Findings.</b>	Wallace, R. & Sons Mfg. Co., 3 Park Place, 6
Lusk, G. W., 501 Masonic Temple, Chicago, Ills..... 21	Lind, Thos. W., Providence, R. I. 42	Whiting, F. M. & Co., North Attleboro, Mass. 16
Prince, J., 137 Broadway, N. Y. 38	<b>Jewelers' Lamps.</b>	Wood & Hughes, 16 John St., N. Y. 37
Scott, De B. O., 20 Murray St., N. Y. 44	Hinrichs & Co., 31 Park Place, N. Y. 36	<b>Spectacle and Eyeglass Cases.</b>
Rich, H. M. & Co., Boston, Mass. 42	<b>Jobbers, Watches, Diamonds, Etc.</b>	Birmingham, Wm. & Co., 728 Arch St., Phila. 44
<b>Badges, Medals, Etc.</b>	Allen, Benj. & Co., Chicago, Ill. 19	White, W. B. & Son, Boston, Mass. 38
Stockwell, E. R., 19 John St. N. Y. 44	Brethauer Watch and Jewelry Co., Chicago, Ill. 19	<b>Stem Winding Attachments.</b>
<b>Chronometers.</b>	Cross & Beguelin, 17 Maiden Lane, N. Y. 2	Abbott, Henry, 2 Maiden Lane, N. Y. 42
Bliss, John & Co., 129 Front St., N. Y. 34	Friedlander, R., L. & M., 30 Maiden Lane, N. Y. 28	<b>Tissue Paper.</b>
<b>Clocks, French, English and American.</b>	Myers, S. F. & Co., 48 Maiden Lane, N. Y. 44	Dexter, C. H., & Sons, Windsor Locks, Conn. 4
Jacques, Chas., Clock Co., 22 Cortlandt St., N. Y. 44	Oppenheimer Bros. & Veith, 35 Maiden Lane, N. Y. 43	<b>Thimbles.</b>
<b>Cut Glass.</b>	<b>Leather and Silver Goods.</b>	Ketchum & McDougal, 198 Broadway, N. Y. 24
Mt. Washington Glass Co., New Bedford, Mass. 38	Deutsch Bros., 7 E. 17th St., N. Y. 2	<b>Tortoise Shell Goods.</b>
Clark, J. B. & Co., 860 Broadway, N. Y. 28	<b>Musical Boxes.</b>	Potter, W. K., Providence, R. I. 5
<b>Diamond &amp; Precious Stone Importers.</b>	Jacot & Son, 39 Union Square, N. Y. 2	Rice & Hochster, 485 Broadway, 26
Disselkoen, John N., 19 E. 16th St., N. Y. 27	<b>Optical Goods.</b>	<b>Tool Manufacturers and Dealers.</b>
Falkenau, Oppenheimer & Co., 40 Maiden Lane, N. Y. 44	Johnston, J. M. & A. C. Masonic Temple, Chicago 23	American Watch Tool Co., Waltham, Mass. 24
Fera, Henry, 10 Maiden Lane, N. Y. 44	McIntire & Ulmer, cor. 8th and Sansom Sts., Philadelphia, Pa. 8	Bullock, O. W. & Co., Springfield, Mass. 11 38
Hedges, Wm. S. & Co., 170 Broadway, N. Y. 26	Queen & Co., Philadelphia, Pa. 38	Hardinge Bros., Chicago, Ill. 19
Kipling, E. E., 182 Broadway, N. Y. 44	Racine Jewelry & Mfg Co., Racine, Wis. 21	Logan, A. J., Waltham, Mass. 5
Kipling, R. A., Hays Bldg., N. Y. 26	Scheidig, John, 43 Maiden Lane, N. Y. 37	Moseley & Co., Elgin, Ill. 21
Lorsch, Albert & Co., 37 Maiden Lane, N. Y. 44	Spencer Optical Mfg. Co., 15 Maiden Lane, N. Y. 38	Oliver, W. W., Buffalo, N. Y. 21
Randel, Baremore & Billings, 29 Maiden Lane Rothschild, M. D., 41 & 43 Maiden Lane, N. Y. 44	<b>Optical Schools.</b>	Waltham Watch Tool Co. 7
Sondheim, Samuel, 20 John St., N. Y. 11	The Chicago Ophthalmic College, Chicago, Ill. 21	<b>Trunks and Traveling Bags.</b>
Smith, Alfred H. & Co., 182 Broadway, N. Y. 26	<b>Paneled Metal.</b>	Crouch & Fitzgerald, 161 Broadway, N. Y. 5
Stern Bros. & Co., 30 Maiden Lane, N. Y. 26	Northrop, A. & Co., Pittsburgh, Pa. 42	<b>Watch Manufacturers.</b>
Tannenbaum, L., & Co., cor. Maiden Lane and Nassau St., N. Y. 15	<b>Pens, Pencil Cases, Etc.</b>	Charmilles Watch..... 13
<b>Diamond Jewelry.</b>	The Boston Pen Co., Boston, Mass. 37	Waltham Watch Co., Waltham, Mass. 8
Jeanne, Paul, Bradley Bldg., N. Y. 38	<b>Patents.</b>	<b>Watch Case Repairers.</b>
Leonhardt & Curran, 44 1/2 Maiden Lane, N. Y. 42	Belt, C. T., Washington, D. C. 5	The Planchamp & Becker Co., Chicago, Ill. 19
Louis Bornemann, 106 & 108 Fulton St., N. Y. 41	<b>Platinum Importers.</b>	<b>Watchman's Clocks.</b>
Keim, John R., 21 East 17th St., New York. 4	Schawel, J. & Co., 29 John St., N. Y. 44	Hausburg, O. E., 41 Maiden Lane, N. Y. 38
<b>Fine Stationery.</b>	<b>Ring Makers.</b>	<b>Watch Glasses.</b>
Parsons & Greene Co., 18 Murray St., N. Y. 5	Bryant, M. B. & Co., 10 Maiden Lane, N. Y. 37	Fisher & Sons, 63 Nassau St. 11
<b>Gold and Silver Plating Works.</b>	Bowden, J. B. & Co., 192 Broadway, N. Y. 7	<b>Watch Importers.</b>
Bolstad Mfg. & Plating Co., Chicago, Ill. 22	Princess Ring Co. 17	Hyde's, J. E., Sons, 22 Maiden Lane, N. Y. 38
<b>Gold and Rolled Plate Jewelry.</b>	Wood, J. R. & Sons, 14 John St., New York. 7	Leon Hirsch, 45 Maiden Lane. 28
Foster & Bailey, Providence, R. I. 3	<b>Safes.</b>	Robert, Edmond E., 21 Maiden Lane, N. Y. 44
<b>Gold Jewelry.</b>	Mosler, Bahmann & Co., 518 B'way, N. Y. 43	<b>Watch Keys.</b>
Carter, Sloan & Co., 15 Maiden Lane, N. Y. 27	<b>Sample Trunks.</b>	Clark, A. N., Plainville, Conn. 43
Johnson R. M., 67 Washington St., Chicago, Ill. 19	Crouch & Fitzgerald, 161 Broadway, N. Y. Y	<b>Watch Repairers.</b>
Krementsz & Co., 182 Broadway, N. Y. 2	<b>Silver Mounted Ebony Goods.</b>	Muller, Hugo, Chicago, Ill. 23
Pfeil, Chas. H., Chicago, Ill. 21	Deutsch Bros., 7 E. 17th St., N. Y. 2	Henry, Peter, Cincinnati, O. 19
Schwartz, W. H., & Co., Newark, N. J. 7		
Smith, Wm., & Co., 5-7 Maiden Lane, N. Y. 43		
Webster, G. A., Chicago, Ill. 43		



## Special Notices.

Rates 75c. per insertion for notices not exceeding 5 lines (25 words); additional words 2 cents each. If answers are to be forwarded, postage stamps must be enclosed. Two insertions, 15 per cent. off three insertions, 20 per cent. off; four insertions or more, 25 per cent. off. Payable strictly in advance. Display cards on this page will be charged at \$2.00 per inch for first insertion, subject to same discount as above for subsequent insertions.

Under the heading of **Situations Wanted** on this page advertisements will be inserted for **One Cent a Word**. This offer refers to **Situations Wanted only**. Payable strictly in advance. If answers are to be forwarded, postage must be enclosed.

## Situations Wanted.

Notices under this heading **ONLY** are charged at one cent a word, payable strictly in advance. If answer are to be forwarded, postage must be enclosed.

**WANTED, SITUATION**—Manager of a business for two years past. Do all branches of work—watchmaking, engraving, seal making, jobbing, selling, buying. Box 695, What Cheer, Ia.

**WANTED** by a first-class watchmaker, with an excellent equipment of tools, a place in a first-class jewelry establishment, New York or Brooklyn preferred. Samples of workmanship sent for inspection, if required. Reference, E. H. Thrall, 3 Maiden Lane, N. Y. Address W. H., No. 7 Decatur St., Brooklyn, N. Y.

**SITUATION WANTED** as watch and clock maker; also jewelry repairer; age 21; speaks English and German; good references. Address A. Guenther, 875 Sixth Ave., New York.

**SITUATION WANTED** by young man. Good watch and jewelry repairer. Owns tools and lathe. Best references. Address F. W. S., Box 342, Birmingham, Conn.

**FIRST** class workman wants situation. Watchmaker, jeweler and letter engraver; owns tools; can furnish A1 references; southwest preferred. State salary. Address Lock Box 595, Pensacola, Florida.

**A** GOOD all round workman wants to make a change. Good watchmaker, engraver and manufacturing jeweler. Hard enameler in all colors. Good on Knight Templar charms, fine badges and diamond mountings. Have the latest tools for all work. Good references. Address Jeweler, 100 Hammond St., Bangor, Maine.

**A** FIRST-CLASS watchmaker, engraver and salesman; complete set of tools; A1 references; single; wants a permanent positron. Address E. E. L., care of THE JEWELERS' CIRCULAR.

**SITUATION** wanted by first-class all around man, 22 years of age, five years' experience; full set of tools; strictly temperate; no chippy chaser. Address 133, care of THE JEWELERS' CIRCULAR.

**POSITION** wanted by lady stenographer, rapid and accurate; willing to assist in office work; salary moderate; best references. Address Steno, care of THE JEWELERS' CIRCULAR.

**WANTED**—A situation by a competent, practical watchmaker of many years experience; German; city or country; Address Bach, 101 9th St., New York City.

**WANTED**—Position as watchmaker, engraver and salesman, by young man with good references; owns full set of tools. Address F. O. R., 403 N. 4th St., Steubenville, Ohio.

**YOUNG MAN**, 12 years' experience in the diamond and general jobbing business, able to take entire charge of any such business, with established trade and first class references, is open for an engagement. Address Active, care THE JEWELERS' CIRCULAR.

**WANTED**—Position as first-class watchmaker; experience and constant practice of over 20 years in English and American watchmaking and in all fine and complicated work; references and tools. Address Crescent Street, care of JEWELERS' CIRCULAR.

**FIRST-CLASS** practical lapper and polisher wants position; used to all kinds of best diamond mountings; capable of taking charge of polishing department; would go anywhere for good position. Address Practical, 7 Clifton Ave., Newark, N. J.

**WANTED**—Position by man experienced in both retail and manufacturing jewelry business. Would prefer to travel part of time. Address L. A. W., this office.

**A** GOOD reliable watchmaker wants position with a first class firm. Address Pivot, care THE JEWELERS' CIRCULAR.

**A** GOOD all-round man, watchmaker, jeweler and salesman. Has good set of tools. Is a fair engraver and can give first-class references. Address J. S. J., care THE JEWELERS' CIRCULAR.

**A** THOROUGHLY reliable man having acted for five years as New York representative for a corporation doing an export business with South America, Central America, Mexico and the West Indies, wishes to negotiate with manufacturing jeweler with a view to making arrangements to act as representative for the introduction of their goods in the above mentioned countries. Address Foreign, care of THE JEWELERS' CIRCULAR.

## Help Wanted.

**WANTED**—A salesman traveling through Southern States selling retail jewelry trade to take a side line. Address B., care of THE JEWELERS' CIRCULAR.

**WANTED**—Traveling salesmen in all parts of the United States to carry an illustrated pocket catalogue and price list of Grout's Excelsior Watch and Spec Signs, and Watch Tools, Foot Wheels, Polishing Lathes, &c., for Jewelers' use. Big money as a side line. Can be carried in the pocket. Every traveler should carry it. Write for agency. Excelsior Sign and Mfg. Co.; L. S. Grout, Manager, 56 State St., Chicago.

**WANTED**—Man to take the place of watchmaker on vacation for three weeks. Will give \$60 for the engagement. None but a first-class man need apply. "Brittan," care of JEWELERS' CIRCULAR.

**WANTED**—Good watchmaker, repairer and engraver. References required. State wages E. L. Everett, 1225 F St., N. W., Washington, D. C.

**OPTICIAN WANTED**—A retail jeweler eligibly located uptown in New York would let part of store to competent optician. For particulars, address Jos. Friedlander & Bro., 21 John St., City.

## To Let

**BROADWAY STORE** near the Post Office; desirable location; moderate rent; lease. Apply on premises, 2 Astor House.

**TO LET**—Part of office 15 Maiden Lane; steam heat, also burglar alarm. For particulars apply to Martin, Copeland & Co. 15 Maiden Lane, City

**TO LET**—Part of factory with steam power. Center of jewelry district. Moderate rent. J. F. Newman, 19 John St.

## Miscellaneous.

**I** BUY JEWELRY STOCKS - Manufacturers, jobbers and retailers desiring to dispose of surplus or entire stocks of diamonds, watches and jewelry can find quick cash buyer by addressing Stephen S. Harmon, 134 East 96th St., New York City.

## DEMAGNETIZING.

**PERFECT WORK**—Watch repairing in all its branches; all work warranted. Winslow & Penney, 608 Masonic Temple, Chicago.

**FOURTEEN** karat gold solder that will flow on eight karat work; makes a hard solder job a pleasure. With this solder there is no danger of melting low karat specs. No white joints on rings. It is just what you want. Sample by mail 25 cents. F. W. Hall, Sterling Silver Novelties, Columbus Memorial Building, Chicago, Ill.

## For Sale.

**JEWELRY STORE** established for 12 years on one of the best business streets of Chicago; stock and fixtures \$5,000; no bonus; stock neat and salable; fixtures modern, including large new safe; annual sales average \$8,000; repairs, \$1,500; expenses, \$1,800, including every item. Just the place for a practical man who is married, as there is space for six living rooms in the rear of store. Outside business is reason for selling. For further particulars address A. Edwards, care W. H. Kidwell, 410 Milwaukee St., Chicago, Ill.

**\$900** WILL buy fixtures and stock in best town in Northern Ohio: two show cases, regulator, bench, safe, shelving and other fixtures. Best location in town of 3,000. Seven factories, electric lights, water works, three railroads. Must sell on account of health. Address Box 72, Caldwell, Ohio.

**JEWELRY STORE FOR SALE**.—I have made my pile and wish to retire from business. A good chance for someone to do as I have done. For particulars address C. H. R. Cheney, Stoneham, Mass.

**FOR SALE**—The leading jewelry business in the best railroad town of 3,000 inhabitants in Northern Illinois. Only one other store; repair work \$85 per month; rent and lights \$26 per month; stock can be reduced to suit. Address S., care of THE JEWELERS' CIRCULAR.

**FOR SALE**—One of the best paying jewelry businesses in the Indiana gas belt, in a town of 15,000 inhabitants. Best of reasons for selling. Stock will invoice from \$4,000 to \$5,000. Will make payments easy to right parties. Address B, 44, care of THE JEWELERS' CIRCULAR.

**\$2,200** CASH, jewelry store, one lot; dwelling, six lots; established 12 years; no opposition; population, 1,200; stock and fixtures if desired. Address Bargain, THE JEWELERS' CIRCULAR.

**A** SPLENDID opening for a watchmaker with a small capital is offered in a county seat in the Territory of New Mexico. The stock and fixtures will inventory about \$4,000, from which a discount will be made; or, if the purchaser wishes the fixtures only, the matter is optional with him. Fixtures will inventory about \$1,000. They are first class and as good as new. No competition whatever; no jewelry store within 50 miles. All the work one man can do at good prices. Sales have averaged over \$5,000 per annum. Population of town about 2,500, and of county 7,000. Good reasons for selling. Address Business, care of THE JEWELERS' CIRCULAR.

**RAILWAY KING COLUMBUS** at \$12 net. Address C. B. H., care of THE JEWELERS' CIRCULAR.

**\$5,000** for long established retail Jewelry business in city of 100,000 inhabitants; **YEARLY PROFIT ABOVE EXPENSE, \$3,500.** Can be greatly increased by additional capital if desired.

Satisfactory reasons for selling given to parties with necessary cash capital. Address, **CHANCE** care of THE JEWELERS' CIRCULAR.

## FOR SALE.

The Old Established Jewelry Business of G. A. SCHULTZ (Dec'd), is for sale at a great bargain. New fixtures throughout; good location. Address **HELENA SCHULTZ, Ex'trix,** Corner 7th & Market Streets, LOUISVILLE, KY.

## Cheap, Bright Offices To Let

singly or in suites, in the handsome new buildings,

**14 and 45 MAIDEN LANE.**

**Rents \$350 up;** elevator, steam heat, electric lights, etc. **E. A. CRUIKSHANK & CO., 176 Broadway**

## TO LET!

A few extra Light Offices in the modern and fire-proof building, **90 Nassau Street,** Cor. Fulton. Elevator and all latest improvements. Apply to

**G. ARMENY, Room 20.**

## LEGENDS OF GEMS.

BY FRANK SHELLEY.

Gilt edged; bound in leather; a perfect specimen of the printer's and binder's art. Should be in every jeweler's library. Price, \$1.00. For sale by

**THE JEWELERS' CIRCULAR PUB. CO.**





## Our Traveling Representatives

Traveling representatives may consider these columns open for the publication of any news or items of interest regarding themselves or their confreres.



**T**RAVELING men visiting Davenport, Ia., jewelers the past week were: Henry Strauss, Leopold Weil & Co., Louis Hirsch, Lissauer & Co.; A. Marschuetz, Spencer Optical Mfg. Co.; Leo Henle, Sussfeld, Lorsch & Co.; R. L. Robinson, Dennison Mfg. Co.

James W. Hagan, of Hagan, White & Co., started Saturday on his annual Pacific trip.

The following traveling salesmen passed through Detroit, Mich., last week: Frank Thompson, F. Kroeber Clock Co.; E. H. Smith, The Holmes & Edwards Silver Co.; Louis Lassner, Goodfriend Bros. & Lassner; I. W. Friedman; William D. Elcox, Larter, Elcox & Co.; Harry Wilcox, Wilcox & Evertsen; Louis Kaufman, L. Kaufman & Co.; M. Nathan, Rothschild Bros.; Mr. Gallagher, Sinnock & Sherrill; Mr. O'Donnell, Courvoisier-Wilcox Mfg. Co.; Joe Tasker, Canada Smelting & Refining Co.; Sam Arnsberger, John Scheidig & Co.; Joe Nassau, Tagliabue & Co.; Nat Prentiss, Alling & Co.; Chas. Boynton, Wm. B. Kerr & Co.; Mr. Underwood, Champenois & Co.; Mr. Groff, George W. Shiebler Co.

Not many travelers stopped in Indianapolis, Ind., last week. Among the limited number were: A. J. Sherrard, Enos Richardson & Co.; J. J. Somers, Thos. Totten & Co.; David Schwarz, Nicholas Muller's Sons; John J. Robinson, Greene & Knox Mfg. Co.; representatives of Seth Thomas Clock Co. and Courvoisier-Wilcox Mfg. Co.; Mr. Babcock, Crescent Watch Case Co.; Mr. Duncan, American Waltham Watch Co.

Among traveling men in Philadelphia, Pa., the past week were: S. French, Riley,

French & Heffron; John Taylor, Krement & Co.; Wm. Huger, Huger Mfg. Co.; F. Woods, Carter, Sloan & Co.; Otto Wolf, Bippart & Co.; T. G. Frothingham, T. G. Frothingham & Co.; C. Booth, Hutchison & Huestis; Wm. M. Donald, Courvoisier-Wilcox Mfg. Co.; Wm. Wightman, R. F. Simmons & Co.; C. Infeld, Hendricks & Co., and Richard Robinson, Richard Robinson & Co.

Traveling men in Boston the past week included: Arthur Simons, Stern Bros. & Co.; Oscar Stern, Hammel, Riglander & Co.; Sam Levy, L. & M. Kahn & Co.; I. Russell, L. Tannenbaum & Co.; Charles Power, Ludeke & Power; Elmer Wood, Chas. F. Wood & Co.; Harry Barrows, H. F. Barrows & Co.; C. E. Hancock, Hancock, Becker & Co.; Fred S. Gilbert; Henry G. Thresher; John A. Abel, Lewis, Kaiser & Luthy; O. Campbell, Day & Clark; T. B. Wilcox, Pairpoint Mfg. Co.

W. S. Robinson, northern New England traveling man for the Ripley-Howland Mfg. Co., Boston, Mass., has returned from his southern outing and is greeting old friends on his circuit again.

Fred H. Carpenter, formerly the Columbus Watch Co.'s representative in New England, has made his reappearance in Boston much to the delight of many friends, after a western trip of some three months' duration.

Members of the fraternity favoring Syracuse, N. Y., with a call the past week were: F. W. Bliss, Unger Bros.; Henry Heyman, Koch, Dreyfus & Co.; J. Goldberg; Frank E. Harmer, Solidarity Watch Case Co.; William M. Clements, Waterbury Clock Co.; Jacob Schorsch, I. Emrich & Co.; Fred H. Miller, Shoemaker, Pickering & Co.; W. F. Corey, Corey & Osmun; W. J. Carrow, Mandeville, Carrow & Crane; E. J. Wilkins, Frederick S. Mills; Ben Posner, Wallach & Schiele; E. W. Wagner, Leon J. Glanzer & Co.; Benj. Westervelt, Waterbury Watch Co.; Jacob Adler, L. & J. Adler & Co.; E. W. Ely, Derby Silver Co.; M. Adler.

Traveling men in Pittsburgh, Pa., last week, were: Samuel Stern, S. Stern & Co.; A. H. Atwood, Towle Mfg. Co.; Charles

Perret, Jules Racine & Co.; Charles Ketcham, Riker Bros.; Lou Smith, Bippart & Co.; Dick Robinson, Richard Robinson & Co.; Mike Lambert, H. Zimmern & Co.; Wm. McDonald, Courvoisier-Wilcox Mfg. Co.; Wm. Platt, Foster & Bailey; Mr. Granbery, Reeves & Sillocks; Mr. Mumford, Waite, Thresher Co.; A. M. Kline, Ezra F. Bowman & Co.; S. L. Barbour, Barbour Silver Co.; Mr. Schwab, New Haven Clock Co.; Fred P. Foster, Unger Bros.; C. W. Cary, J. B. & S. M. Knowles Co.; Ben Shiers, A. Pinover & Co.; G. W. Hull, Silver Plate Cutlery Co.; and M. D. Rothschild.

### Pittsburgh.

Steele Roberts and family will go to Atlantic City this week.

B. Grossden, Waynesburgh; J. H. Bruce, Burgettstown; and B. Neville, Dawson, were in the city last week.

W. W. Wattles has taken out a building permit for an \$8,500 brick dwelling to be erected on Wallingford St., East End.

William Woblinsky, Wylie Ave., who is out on \$25,000 bail, is indebted to I. Ollendorff for \$500. Woblinsky has played havoc among business men in this city.

Henry Zimmern & Co., of New York, have purchased the entire stock of material of Jos. Stanger & Co. Mr. Lambert made the deal when in the city last week, and shipped the goods home.

Heeren Bros. & Co. are now comfortably settled in their handsome and extensive new building, corner Penn Ave. and 8th St. The establishment has been built and arranged to meet the requirements of the firm's growing trade, and they are now in a position to display their large and varied stock to better advantage than heretofore, and to increase their facilities as manufacturers, importers and jobbers, to an almost unlimited extent. The first floor of their building is the general salesroom; the second floor is devoted to the display of imported goods, clocks, bronzes, bric-à-brac, etc.; while the third floor is fitted up as a complete factory. A newly designed business card of the firm depicts the beautiful arch of the entrance of the building.

M. Guggenheimer & Sons, of New York, have bought a large manufacturing site in the northern part of Perth Amboy, N. J., where they will erect a copper, lead and silver refinery, which will cost \$1,000,000. They expect to employ 1,000 men.

A hearing took place in Alderman Jackson's office, Harrisburgh, Pa., a few days ago, in which William Bellman, who formerly kept a jewelry store on Market St., was the defendant and Mrs. Rasbridge, of Columbia, the prosecutor. Mr. Bellman has been identified with a building and loan association in Harrisburgh as secretary, and is charged with not paying money to the treasurer which was placed in his hands for that purpose by the plaintiff.

ESTABLISHED 1870.

## J. L. CLARK,

### SWEEP SMELTER AND REFINER OF GOLD AND SILVER.

Buys every kind of Gold and Silverware, Jewelry, Watches and Platium. Full market value paid.

No. 724 Filbert Street, Philadelphia, Pa.

SEND BY EXPRESS or Registered Mail. If my price is not satisfactory, I will return all articles



## MARINE CHRONOMETERS,

MANUFACTURED BY

### John Bliss & Co., 129 Front St., New York.

We have on hand a number of Chronometers, by various good makers, not new, which have been in service for purposes of navigation, and are excellent instruments. They have been put in perfect repair and will give satisfactory results as to performance. We will sell these Chronometers at low prices, either for cash, or on accommodating terms to suit special cases, or will hire them at moderate rates and allow the hire to apply on purchase.

SEND FOR CIRCULAR GIVING PRICES AND TERMS.



**The Latest Patents.**

ISSUE OF APRIL 24, 1894

**518,595. CUFF-BUTTON.** JAMES A FLOMER-FELT, New York, N. Y.—Filed April 8, 1893. Serial No. 467,500. (No model.)

A cuff-button for link cuffs, comprising a connecting bar having an angular central portion arranged within



the cuff to hold the ends thereof apart, and the heads mounted concentrically on the ends of said connecting bar parallel with the respective sides of the angular central portion and adapted to clamp the cuff against said sides, whereby the ends of the cuff are separated and maintained in a rigid position.

**518,650. CANDELABRUM.** ALPHONSE C. MCKERCHER, Montreal, Canada, assignor to Albert Gauthier, same place.—Filed August 3, 1893. Serial No. 482,324. (No model.)

In combination the standards, the series of shields each having rack teeth R, the series of parallel arms or rods 1, 2, the said rods 2 being pivoted to the shields,

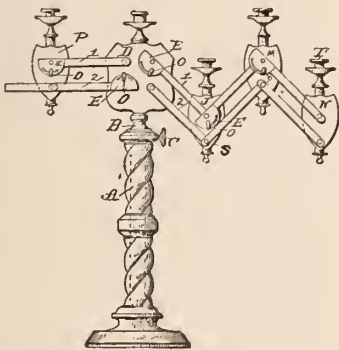

each of the said rods 1 having at one end a slotted face plate E pivoted to one shield, and having its opposite end pivoted to the next shield and axially of the face plate of the next arm 1 and the clamp screws for holding the slotted face plates, the pairs of arms 1, 2, with their respective face plates and shields being capable of adjustment independent of the other pairs of arms with their shields and face plates.

**518,712. WATCHCASE.** CALEB K. COLBY, Brooklyn, N. Y.—Filed Aug. 18, 1893. Serial No. 483,432. (No model.)

A watch case composed of a ring d, to hold the movement provided with a pendant or stem, and two caps, a and b, which are hinged together and to the

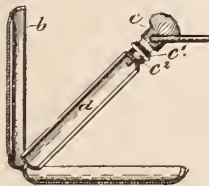

ring d at a common point opposite to the pendant, said caps having undercut and matched marginal flanges which snap together when the caps are closed, the caps thus forming a housing for the ring.

**518,720. COIN-CONTROLLED APPARATUS.** CHAS. H. JACOT, Stapleton, assignor to Jacot & Son, New York, N. Y.—Filed Sept. 13, 1893. Serial No. 485,426. (No model.)

In a coin-controlled apparatus, the combination of a

suitably mounted counter-balanced coin receptacle open at the top and one side, together with a cam on a shaft adjacent thereto adapted to rock the receptacle

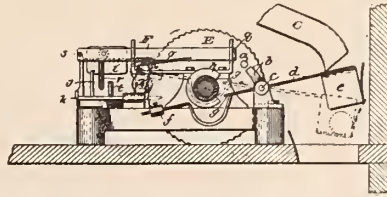

to eject the coin, whereby the coin will be retained within the receptacle when it is in its lowered position and discharged when it is again forced into its normal position.

**DESIGN 23,209. HANDLE FOR SPOONS, &C.** CHARLES OSBORNE, New York, N. Y., assignor to the Whiting Manufacturing Co., same place.—



Filed Mar. 1, 1894. Serial No. 502,000. Term of patent 3 1/2 years.

**DESIGN 23,210. FINGER-RING.** WILLIAM O. HUTCHINS, Providence, R. I.—Filed Mar. 8,



1894. Serial No. 502,912. Term of patent 7 years.

**DESIGN 23,213. COVERED DISH.** MARTIAL



REDON, Limoges, France.—Filed September 20, 1893. Serial No. 486,035. Term of patent 7 years.

**DESIGNS 23,215, to 23,218. PICTURE-FRAMES.** LOTHAR VON GRAVE, Wallingford, Conn., assignor to the H. L. Judd & Company, New York, N. Y.—Filed Mar. 27, 1894. Serial Nos. 505,343,505,346. Terms of patents 3 1/2 years.

**Expired Patents.**

EXPIRED APRIL 24, 1894; GRANTED APRIL 24, 1877.

**190,105. ORNAMENTAL CHAINS.** H. WENEL, E. Attleborough, Mass. Filed Sept. 9, 1876.



As an improved article of manufacture, a double-curb chain formed of the links a, bent or twisted into the shape described and shown, and united together without the employment of solder.

**190,058. WATCHMEN'S TIME-DETECTERS.** J. H. MARVIL, Laurel, Del. Filed March 21, 1877.

**189,998. ELECTRIC CLOCKS.** C. F. BRUSH, Cleveland, O., assignor of one-half his right to the

Telegraph Supply Co., same place. Filed Aug. 28, 1876

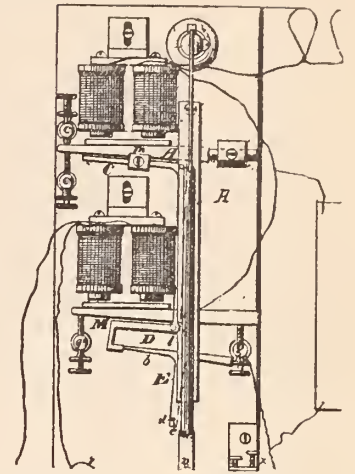

The pendulum-actuating lever, in combination with the clutch or dog E, provided with springs e and pin d,

**7,633. MANUFACTURE OF TABLE-FORKS AND SPOONS.** LE ROY S. WHITE, Waterbury, Conn., assignor to Brown & Bros., same place. Patent No. 178,218, dated May 30, 1876. Filed Mar. 29, 1877.



The improvement in the art of manufacturing forks and spoons, consisting in cutting out a blank with a lateral swell in the shank, or with the shank of a width greater than is required for the finished article, and subsequently condensing or hardening the metal in the shank by pressure applied in a direction transverse to the direction of the pressure produced in the rolling of the blank, and of the sheet from which it has been cut.

**The "Charmilles" Watch on the Market.**

It is with much satisfaction to the trade that the "Charmilles" watch has at last been placed on the market. The demand for these watches is so large that it has been impossible to accommodate it; but every effort is being made to increase the supply, and very soon every dealer wanting the watch will have the opportunity.

It is not marvelous that the demand is so great, for in superiority of construction and elegance of design the "Charmilles" has much to commend it. The old silver finish and oxidized steel with applied designs are really elegant and novel. As a rule, low priced watches are plainly cased, but with the "Charmilles" the cases are attractive and extremely neat. To the many gentlemen who desire a watch when traveling, fishing, hunting and wheeling, this watch will prove desirable.

E. L. Spencer & Co., Providence, R. I., are increasing their office room by one half. The firm are showing a very popular line of white stone goods in earrings, pins, drops and studs, all displayed in cases and trays of novel construction and handsome appearance.



**Screw Head Tool.**

THESE are of various kinds; some work by hand and others by the bow. The jaws are brought together sometimes by a sliding ring, and at others by a milled head placed between them and rigidly attached to a pin tapped with right and left handed threads that engage in the jaws. But neither of these plans is good; the screws are not held firmly, and they are rarely well centered, owing to the slight displacement of the jaws. The English screw head tool is a simple lathe. A better plan is to arrange, either in the lathe or in the jaws of the screw head tool (when driven

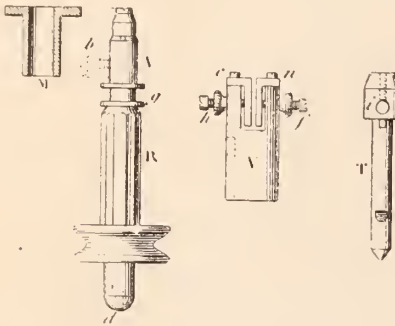

by the bow), a series of chucks of the form shown at T, of accompanying illustration. They are easily made and tapped, the hole *z* serving to remove the metal from the inner end of the hole that has to be tapped; such chucks occupy very little space, and, if numbered to correspond with the size of screws, any chuck required can be found without trouble. If the hole becomes too large, owing to frequent use, a larger size of tap can be passed through the hole and its number changed.

A set of such chucks is almost indispensable at the present day to the watchmaker who wishes to repair watches well; for he rarely makes his own screws, as they are to be obtained well made and very cheap at the material dealers, whereby a great saving of time is effected. But their heads are seldom of the proper size to fit the original sinks, and by being provided with such a series of chucks, the watchmaker can at once overcome this difficulty, as he can turn the heads down with a graver.

In the accompanying illustration, R is an arbor for a screw head tool that is driven by

a bow, and is adapted to receive such chucks, or it can be used in an ordinary pair of turns, *d* being supported on a pointed center, and *g* in a boring-plate or in a cone-plate center. In this form of screw head tool the portion A is sometimes cylindrical, so that the piece V can slide onto it, being clamped by the screw *b*.

This tube V is cut away through about half its length with a notch, as indicated in the figure; bent pieces of hardened steel *c* and *n* are screwed to either side of the notch. Screws *h* and *f*, provided with lock nuts, determine the distance between these plates, and when V is in position on A the ends of *c*, *n*, rest on the screw-head, leaving just sufficient space between them for inserting the file that cuts the slit.

Hard steel caps of the form shown at M may also be fitted to A, a notch being cut in them to receive the screw *b*. These will be found useful as guides for filing or polishing screw heads, or the ends of arbors flat, reducing the heads of several screws to the same height, etc.

It will also serve as a tool for drilling; a drill chuck with drill *f*, being adapted to A, and the object to be perforated at *b* resting against a plate that projects at right angles from a slit *ed*, which may be advanced by a screw *g*.

**The Pendulum for Determining the Shape of the Globe.**

THE readers of THE CIRCULAR, being principally engaged in horological pursuits, know that the velocity of the pendulum oscillations depends upon the length of the pendulum as well as upon gravity, which varies at different points of the globe. It is strongest at the poles and feeblest at the equator, for two reasons: first, it is influenced by the centrifugal force of the revolution of the globe, which opposes it, and next by the greater or smaller distance from the center of the globe, or perhaps better said, center of gravity.

When, now, pendulums of equal length are caused to oscillate at different localities upon the surface of the earth, the larger or smaller velocities tell us, first, the distance of the corresponding locality from the rotary axis, and, second, the distance from the center of gravity. The established formulae for calculation are generally for the purpose of ascertaining the length which the pendulum must have at different localities of the earth to produce a unit velocity—one oscillation per second.

A noteworthy number of scientists, of all countries—Sabine, Foster, Schmidt, Airy, Bowditch, Baily, Borenius, Pouillet, Fischer, and others—have to ascertain the length of the seconds pendulum instituted probability calculations, each of which is based on a certain number of pendulum measurements (from 13 to 79) which have taken place at different points of the earth. The results of the calculations vary between 990.987 millimeters and 991.277 mm. length for a seconds pen-

dulum at the equator and 996.123 mm. and 996.419 mm. at the poles; consequently they vary nearly 0.3 mm. But since the entire increase of the pendulum length for the 90° of latitude, from the equator to the pole, amounts to only 5.14 mm., the seemingly trifling difference of 0.3 mm. corresponds to a latitude difference of about 5°.

The following table is a summary of these deviations:

Localities.	Latitude.	Length of seconds pendulum. Millimeters.
St. Thomas.....	0° 24' 41"	990.84
Mararhan.....	2° 31' 43"	990.84
Ascencion.....	7° 55' 48"	991.15
Sierra Leona.....	8° 29' 28" N. }	991.02
Trinidad.....	10° 38' 56" N. }	
Bahia.....	12° 59' 21" S.	991.15
Jamaica.....	17° 56' 7" N.	991.42
New York.....	40° 42' 43" N.	993.15
London.....	51° 31' 8" N.	994.07
Drontheim.....	63° 25' 54" N.	995.21
Hammerfest.....	70° 40' 5" N.	995.49
Greenland.....	74° 32' 19" N.	995.69
Spitzbergen.....	79° 49' 58" N.	995.99

To reiterate, the preceding table shows that the seconds pendulum is shorter near the equator than in the higher degrees of latitude, from which scientists deduced that the earth is no true ball, but a spheroid, that is flatter near the poles and arched toward the equator. The shorter the diameter of the earth is at a given locality the stronger will an object upon its surface be attracted by gravitation; for which reason, also, a pendulum will there oscillate somewhat faster than in higher regions, and must consequently be made longer to obtain the same unit of time.

**Putting in a Roller Jewel.**

TO put in a roller jewel, select one as large as the fork will take and be free; any unnecessary shake in the fork is not merely a loss of power, which may be supplied by a strong spring, but is detrimental to good timekeeping. Do not attempt to set the jewel with the roller on the staff; and to remove it the best appliance I have seen is a little table made for the purpose and which can be had at the tool stores. If you have no special tool for setting pins, it can be done very well by holding the roller in the brass-lined pliers, and the latter in the flame of the lamp until heat enough is imparted to flow the shellac; see that the pin is upright to the face of the roller, and that the flat surface of the pin is at right angles to a line through it, and staff center, without reference to passing hollow, as that is often too much out of correct position. After cleaning off the superfluous shellac, which should be done with a brass scraper, similar to a chamfering tool, put the roller on the staff, and the balance in the watch, and see if the jewel pin will pass freely in and out of the fork, and that it performs its function of supplementary safety action; if not, it must be put forward or back, as the case demands.

**FOR JEWELERS' USE.**

G. A. Kleemann's Patent Improved Student Lamp.

C. A. Trade Mark.

**THE GERMAN AMERICAN.**

It preserves all the improvements which have made the St. Germain Student Lamp so acceptable to Watch-makers and Mechanical Jewelers, but is a much larger Lamp, fitted with a nine-inch shade and its new large burner—far superior to that of the St. Germain—gives a light nearly double in brilliancy.

Steady white light, perfect combustion, without much heat, safe against explosion.

Will last a lifetime. Wick easily adjusted. Illustrated circular free.

**HINRICHS & CO.,**  
29, 31 & 33 PARK PLACE,  
NEW YORK CITY.







# L. STRAUS & SONS,



IMPORTERS AND MANUFACTURERS,

China, Pottery and Glassware, 42 44, 46 & 48 Warren St. and 116 Chambers St., N. Y.  
PARIS CARLSBAD, RUDOLSTADT, LIMOGES, STEINSCHONAU.

## The "Bryant" Rings.



Are widely advertised and will sell when anything will, therefore every Retail Jeweler should buy them.

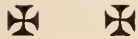

IF NOT CALLED UPON BY OUR TRAVELERS ORDER DIRECT FROM

M. B. BRYANT & CO., 10 MAIDEN LANE, N. Y.

OLDEST RING MAKERS IN AMERICA.



## BIG RETURNS MADE FOR OLD GOLD AND SILVER.

Check Forwarded 24 Hours After Receipt of Consignment.

### J. RATHBONE,

GOLD AND SILVER REFINER, ASSAYER AND SWEEPSMELTER,  
Nos. 1 to 9 Matthewson St., Cor. Cove, Providence, R. I.

## STERLING SILVER . . . . . TABLE WARE,

Manufactured at  
NEWBURYPORT, MASS.



TOWLE  
MANUFACTURING COMPANY.

CHICAGO OFFICE: 149-151 STATE STREET.

*We Know* THAT WE CAN GIVE YOU BETTER RETURNS ON YOUR OLD GOLD AND SILVER OR WASTE THAN ANY ONE ELSE. TO PROVE THIS STATEMENT GIVE US ONE TRIAL.



GEO. M. BAKER,  
GOLD AND SILVER REFINER AND SWEEP SMELTER.  
PROVIDENCE, R. I.

## VICTOR. ⊗ ⊗

SIMPLEST FEED. ALWAYS THE SAME. GUARANTEED FOR ONE YEAR.

### THE VICTOR FOUNTAIN PEN

(Pat. Feb. 4, 1890.)

THE BOSTON PEN CO.,  
N. C. Whitaker & Co., Proprietors.

363 Washington Street, Boston, Mass.,  
Manufacturers of finest quality  
TORTOISE : SHELL : AND : HORN : GOODS  
in every variety. Also Aluminum Hair Pins.  
Send for Illustrated Pen Price List No. 1.

### WOOD & HUGHES, STERLING SILVERWARE MANUFACTURERS

New York Agents for the Derby Silver Co.'s  
FINE QUADRUPLE PLATED WARE,  
No. 16 JOHN STREET, NEW YORK.  
206 Kearney St., San Francisco, Cal.  
HASKELL & MUEGGE, Agents.

## "ECLIPSE" EYE GLASSES AND THEIR ADVANTAGES.

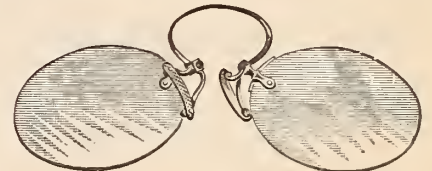

1. The guard remains perfectly rigid in the post.
2. The guard is made of two arms, one running at right angle to the frame and passing through a slot in the post which positively locks the guard.
3. It is easy to fit; for while the angle of the "Eclipse" guards is fixed, the arms of the guards are thin and pliable, so that any desired shape can be given and almost any case fitted with the "Eclipse" guards in the shortest possible space of time.
4. No other guard is so light, clean, and has so little metal.

Send for Circular and Catalogue.  
John Scheidig & Co., 43 Maiden Lane, New York.  
Sole Agents for the "Eclipse" Eye Glasses,  
IMPORTERS and JOBBERS IN OPTICAL GOODS.  
Carry large line of Leading American Frames and Lenses.



# FERDINAND BING & Co.,

106 GRAND ST., N. Y.

NEW DESIGNS IN

China Clocks and Gilt Bronze Sets, Fine Painted Dresden Goods in Vases, Cups and Saucers, and Plates; Cararra. Marble Statuary, French Cabinets and other Fancy Furniture.

## YOUR \* NICER \* TRADE

LOOK FOR

ATTRACTIVE  
PROPRIETARY  
ARTICLES.

WE MAKE THEM.

.. THE ..  
Mount Washington  
GLASS CO.,  
NEW BEDFORD, MASS.



No. 2342. \$2.00 LIST.

PERFECT  
PNEUMATIC  
ACTION.

SALESROOMS:

46 MURRAY STREET,  
NEW YORK.

224 WABASH AVENUE,  
CHICAGO.

220 SUTTER STREET,  
SAN FRANCISCO.

WRITE FOR  
ILLUSTRATIONS AND PRICES.

**J. PRINCE,**  
Jewelry Auctioneer,  
At liberty from January 1st, 1894. Retail  
Jewelers only. Address,  
Rooms 9 & 10, 137 BROADWAY  
N. Y. CITY.

## BUSY BODIES.

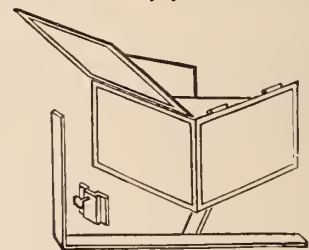

PLACED in the house window show who is coming up the street or who is at the door. The observer remains unseen. These are used very largely in New York and Philadelphia, and are sure to prove popular wherever introduced.

It will pay to obtain an agency from us. Write for circular and prices, mentioning this advertisement.

**QUEEN & CO.,**  
1010 CHESTNUT ST., PHILADELPHIA.

NEW CLOCK STAFF WRENCH.



This entirely new and most useful tool is for setting up clocks, particularly fine and costly ones. Can remove pivots at ease. No chance of displacing other pivots in the operation. For description, send 5c. in stamps for catalogue of over one thousand varieties of fine tools.

O. W. BULLOCK & CO., Springfield, Mass.

**Paul Jeanne,** EIGHTEENTH STREET and 4<sup>TH</sup> AVE., N. Y.

(Bradley Building.)

MANUFACTURER OF

FINE DIAMOND JEWELRY.

SWELL AND EYE WIRE SELLS.

WE PROTECT THE SWELL BY U. S. PATENT. The Swell also protects the retailer by NOT BREAKING. All our gold frames are BUILT THAT WAY. Look you into our A. B. SEE method of teaching OPTIX. First TUESDAY each month.



MAIDEN LANE 15 CO. MFG. OPTICAL SPENCER.

Headquarters  
FOR  
ELECTRIC & PORTABLE  
Watchman's Clocks



Price,  
Complete  
\$10.00

Lowest Prices.  
Latest Improvements,  
Patents 1886-1893.  
Send for Circular.  
E. O. HAUSBURG,  
41 Maiden Lane, New York. THE "ALERT."

WHITE'S EYE SHADE. **W. B. WHITE & SON**  
MANUFACTURERS OF



Spectacle and Eye Glass  
CASES

90 SOUTH STREET, BOSTON.

Special Cases made to order for Optical Trade. Cases for Trial Lenses. Opera Glasses recovered, etc. Chatelaine Spectacle Cases Metal Bound Leather Cases for combs, scissors etc. Over forty kinds of cases manufactured.

**Jules Jürgensen**  
OF COPENHAGEN.

The reputation these watches have maintained for Fifty Years has never been equalled, being made on strictly scientific principles and no expense spared to give the Best results in mechanism and timekeeping qualities.

SOLE AGENTS.

**John C. Hyde's Sons,**  
NO. 22 MAIDEN LANE.





### The Austerlitz Vase.

**I**N a neat brochure, the Shreve, Crump & Low Co., Boston, Mass., give the history and description of the famous Austerlitz Vase, as follows:

On the 15th of November last (1889), there were sold at Versailles several pieces of rare old furniture, and other objects that were practically out of use, among them a curious card table and "lavabo" made of maple, in the purest and finest of Empire style. These, however, are hardly worth mentioning, that which followed being the great event, or calamity of the day. At the end of the sale, without any notice or mention of the fact, an immense and superb Sèvres vase was placed on the stand before the astonished eyes of the few people who had known of the sale and come to attend it. This vase was made in the royal manufactory, by order of the great Napoleon, to celebrate his famous battle of Austerlitz, and as a national monument for the palace. It is of the finest hard paste porcelain, and of the most perfect proportions and purity of style. It copies in form and color the vases of the best Etruscan period, that of the third century B. C., and is truly Etruscan in spirit and feeling. In subject, the design represents a warrior mounted in his chariot, drawn by four flying coursers. The warrior has the features of Napoleon. Upon the chariot is the inscription, "*Bataille d'Austerlitz.*" and upon the shield of an attending angel, one reads, "*Veni, Vidi, Vici.*" Upon the reverse is the noble French eagle, with broadly spreading wings.

A distinguished artist, who attended the sale, says: "This vase, of the most beautiful epoch of the Empire style, made especially for the palace of Versailles, was broken in 1872 by the clumsiness of an employe of the museum in moving it to a place of safety at the time when the National Assembly occupied the palace. It bore the number 357 on the catalogue of the inventory of the museum. The administrators of the estate of Versailles, of the museum or the palace, having run short of funds, secretly and silently put this superb vase at sale in a public auction, at the last moment of the last day. It was a most regrettable act, for the vase was not only re-

markable as a work of art but most unusual in style, made by the National manufactory and a historical monument, marking one of the most glorious battles ever fought by France."

From *La Curiosité Universelle*: The beautiful vase, of Etruscan style and made in porcelain of Sèvres, which has lately been sold at public auction by the Museum of Versailles, on account of being broken (*on dit*), has been restored. Amateurs and lovers of the beautiful will have an opportunity of viewing it at the rooms of Hustinx, the celebrated merchant of curiosities and old-style furniture, corner of Rue de Miromesnie and Boulevard Haussman. This vase, the paintings on which, seem to belong to the manner of the younger Fragonard, is certainly one of the most beautiful gems that commerce has been able to obtain possession of for many a year. It has been purchased by Shreve, Crump & Low Co., of Boston, and will probably be placed in a foreign museum. Such acts of vandalism should never be allowed by the French Government, and what was spared by our enemies should never be sacrificed by the hands of Frenchmen.

The vase stands upon a carved wood pedestal and is superbly mounted in gold bronzes, chiselled and gilded by the famous Thomire, and set about with attributes exquisitely cut and designed.

### Primrose Bowls.

**F**OLLOWING out the principle of the glass rose bowl, a firm of London dealers have brought out a new "Primrose Bowl." The article is made in art pottery ware, with raised foliations and shell work. The shape reminds one of a round footstool, standing on knobs. The top is evenly perforated for the reception of the short stems of the primrose; but, of course, the bowl can be used equally as well for daisies, roses, or any other short stemmed flowers. For table decorative purposes nothing neater or cheaper or more useful, everything considered, could be imagined.—*The Pottery Gazette* (London).

### The Rambler's Notes.

WHAT THE RAMBLER SAW AND HEARD AMONG THE DEALERS IN ART POTTERY, CUT GLASS, BRONZES, ETC.

SALE OF CHINESE PORCELAINS.

**A**T the American Art Galleries, New York, took place a few days ago the sale of the Chinese porcelains collected by E. O. Arbutnot, a well known dealer and connoisseur of Shanghai. The collection embraced a few decorated pieces belonging to the estate of T. E. Davies, of Hong-kong, and some that have figured in recent sales here. It was particularly strong in blue porcelains, which at one time had so great a vogue in England that the finest pieces in other tones were neglected for comparatively poor articles in this fashionable color. The sale commenced last Wednesday and continued until Saturday. There have been sales in New York of Chinese porcelains which had a higher average than this one, but none with such a variety and number of pieces above mediocrity.

\*

NOVELTIES IN HACHE PORCELAIN.

**H**ORACE CRAIGHEAD, the New York agent for the china of Alfred Haché & Co., Vierzon, France, has opened some beautiful additions to his novelties in this ware. Among these is a line of fish sets in the latest shape, the Marquese, which shows a new effect in decoration. This consists of groups of small fish in bright and natural colors, in combination with sprays of field flowers of delicate shades. Additions have also been made to the Empire tea, coffee, and after dinner cups, which contain decorations of shaded blue with gold relief sprays, as well as to the trays, in pin, pen, brush and comb and manicure sizes. These have both the floral and the relief gold decorations. The beauty of the Marquese shape is seen in the comports, of which a variety is shown.

\*

TEAKWOOD FURNITURE.

**C**ARVED teakwood furniture is always striking, and always a good investment. It comes to us



## The Connoisseur.

(Continued from page 39.)

from the east. It is guiltless of anything but pure handwork, and it will endure forever, or, at least, as long as the mortal mind can grasp. Just now there are some splendid specimens to be had from A. A. Vantine & Co., 877 Broadway, New York, at comparatively low prices, and dealers wishing to buy would do well to take advantage of the fact.

\*

BEAUTIFUL  
LIMOGES NOVELTIES.

**A** MORE beautiful display of rich Limoges novelties

than the assortment recently opened by P. H. Leonard, 76 Reade St., New York, it would be difficult to find. The predominating feature of this new line is a rich cream ground in soft matt finish on which the artistic floral decorations seem to stand out in relief. The two leaders of the new shapes are the Foster and Vauban, the former having an artistic shell effect, and the latter being a beautiful adaptation of the Louis XVI. style. The line is particularly rich in trays. Comb and brush, manicure, spoon, pin, pen, desk and ring trays are shown in a greater variety of shapes than ever before, among them being the Foster and Vauban previously mentioned, Lis and many leaf shaped varieties, together with a number of new and original conceptions in jewel and ring trays. Among

other novelties of interest to jewelers are the after dinner coffee and other cups, jewel boxes, individual sugars and creams, and the sets of bowls containing the various salad, berry and jelly sizes.

THE RAMBLER.

### The Mali Rifle Cups.

**T**HE two handsome sterling silver prize cups and two bronzes presented by Colonel Henry W. T. Mali of the Seventh Regiment Veteran Association for competition in rifle matches by members of the Veteran's organization were delivered by Tiffany & Co., a few days ago. The aggregate value of six prizes is \$500.

The most costly, the \$250.00 prize, is a beautiful silver cup, standing 17½ inches high. It is a vase in form and Grecian in its general character; the design is particularly rich and pleasing in effect. Around the tapering foot of the vase are several bundles of rods, the Roman and Grecian fasces, symbolical of union and strength. Above these, to the right and left, and rising to the neck of the vase are two female figures in relief, representing Victory. One of each of their arms is uplifted, forming an arch, and supporting at the top a small shield with the inscription. Reaching to the top, on either side, are long branches of palms which make an effective frame for the artistic center design. On the back of the vase is the presentation inscription. The vase weighs 63 ounces, and rests

on an ebony base inlaid with a square of ivory in front, showing a target of good size. This prize is intended for the annual Summer competition at Creedmoor.

The prizes shot for April 14th consist of the other silver cup, valued at \$150, and two handsome bronzes. The silver prize is a two handled loving cup, and while of a conventional shape, it has been treated in such a unique manner that its originality makes it a thoroughly characteristic military trophy. Around the base of the cup and forming its supports, are full sized rifle cartridges, which look dangerously real, but as a matter of fact are merely fac-similes in sterling silver, gilt and oxydized to resemble the genuine ones. The effect is striking. Between the cartridges are spaces for the names, dates, etc., of the winners. The cup stands about 10 inches high, weighs 43 ounces, and has a capacity of six pints.

### Not too Well Known to Advertise.

**O**NE day I said to a great jeweler in the interests of business generally:

"I can't understand why you don't advertise more extensively."

"Why," he replied, "everybody in this country knows of this store."

"Undoubtedly," I replied, "but everybody in this country does not know that one may come in here, spend the day looking at goods, buy nothing, and yet be as courteously treated as the purchaser of a diamond bracelet."

ALL KINDS

FANCY WOOD

CHESTS

FOR

TEA SETS

AND

FLAT WARE.



FANCY KID,

CHAMOIS,

SILKS and

BROCADE

CASES,

FOR

SILVER WARE

AND

JEWELRY.

# HEBBARD & BROTHER,

860 BROADWAY,

NEW YORK.



## SUGGESTIONS FOR WINDOW AND STORE DECORATION.

Members of the trade who think they have an attractive window are invited to send us a photograph, or a pen and ink or pencil sketch of the same, which will be published if we consider the window contains any originality or lesson.

### IDEA NO. LXXII.

**T**HAT effective results may be obtained in window decoration, through simple means, was recently evidenced in the design embodied in the window of F. D. Dunnington, successor to Dunnington & Newlon, Buckhannon, W. Va. The illustration is reproduced from a photograph forwarded to THE CIRCULAR by Mr. Dunnington.



A LANDSCAPE SCENE AS A SETTING FOR A JEWELRY DISPLAY.

The hill was made of two rocks covered with sand. Sand was also placed over the bottom of the window, two inches deep; a piece of glass represented a lake. Small stones were laid in different places, with a pine tree and brush stuck in the sand. The cabin was composed of twigs retaining the bark. Notches were cut in each end to bring the cracks close together; these cracks were filled with clay. The shingles were made from pine boards split into very thin pieces. The chimney was built of sticks. The rail fence was of split sticks with the bark left on. There was an old ash hopper at the corner of the house, and an iron kettle by its side. Two dogs were at the steps near the wood pile, and a pointer at the corner of the house. There were also a shovel and a wood sled. The background was of dark cloth. Flour was spread thereon to resemble snow, the effect being enhanced by diamond dust.

The window was unusually pretty at night, and attracted more attention than anything that had been put in the windows for years.

#### The Window Decorator's Art.

**P**ERHAPS in no other city is window decorating more highly developed than in Brooklyn, N. Y. Fulton St. seems

duller and less interesting than usual when the curtains are drawn down over the big windows of the dry goods, millinery and jewelry stores. There may be just as many people, the life is still there, but the brightness and color are gone.

Although window dressing is undoubtedly an art, it is one of recent growth. Nothing

was further from the artistic than the window displays of 15 years ago, even in the most pretentious establishments. The idea then was to get as much as possible into the window—in fact, to have there all the house had for sale. When the establishment was a large one, doing business in various lines, the result of this policy can be imagined. In unsightly array in one window were shoes, linen, cotton goods, household ware, jewelry and a hundred other things. Carpets or dress goods extending to the top of the window, were used as backgrounds, while from the ceiling hung rugs, lace curtains, and the like in ugly profusion.

Very different is the manner of dressing windows to-day. It is not the aim to make the window a catalogue of the stock. The decorator strives to present an idea worked out in merchandise that will be so attractive to the eye as to draw attention to the window and cause remark. This is one of the best forms of advertisement. This same beauty unobtrusively conveys the impression that the goods within are of the finest quality. Then, of course, the goods themselves are displayed. The decorator who knows his business does not hang material from the ceiling or dress to the top of the window, and he uses but few pieces. Simplicity and directness are the characteristics

of his windows, and they, also, are a practical advantage. It is impossible to avoid slight injury to fine goods that are used for decorating. Dust and handling tell on them despite the care and skill of the dresser, so that it is economic to be sparing of material.

One of the most critical parts of the decoration of a window is the background. It must be attractive of itself, and yet of a nature to set off and harmonize with the other material used. There is a wide range for selection, and the necessity of an accurate and discriminating taste. For some classes of goods, particularly in windows in which there is little material, mirrors make one of the best backgrounds. Beside the windows designed chiefly with a view to attractiveness, there are what are called "selling" windows. These usually display comparatively cheap goods, and are most effective when the material is all of one price and kind.

To be a successful window decorator a man must have the instincts of the artist. He must have a perfect knowledge of color and a true eye for harmony of combination. He must know all about the goods he handles or he will make the mistake of putting expensive material with cheap stuff, which combination nullifies the effect of the former. He must keep a watchful eye on the changes of fashion, as his windows are to some extent an index of the prevailing modes, and he must have a knowledge of drawing. In addition to these qualifications some of the dressers are skilled mechanics. These are the stars of the business—the men who are so valuable to their employers that their salaries, reckoning by thousands, cannot be counted on five fingers.

Nobody realizes more fully than these men that the ultimate object of their work is to draw attention to the house, and every one of them watches with a keen eye the selling effect of each display. And yet it is with the artist's feelings that they regard their windows. The duties are not the perfunctory ones of putting the goods in the windows where they can be seen. Each display is a unity in conception and execution, and to its conceptor is a triumph or a failure.

It is a little curious that window decorating as a profession has no feminine followers. It is work, apparently, for which women, with their inborn taste for dress and color, are pre-eminently fitted, but as yet the men have the field entirely to themselves. There are about a hundred professional window decorators in the United States, a number of whom are Frenchmen. It was in France, indeed, that the art originated. Artistic window dressing in London is still in the embryonic state.

**LOUIS BORNEMANN,**  
**MAKER OF Diamond Jewelry,**  
 Removed to Downing Building,  
 106 & 108 Fulton St., N. Y.



PATENT paneled METAL  
**CEILING**  
Stamped Raised Panels.

ARTISTIC AND PERMANENT.

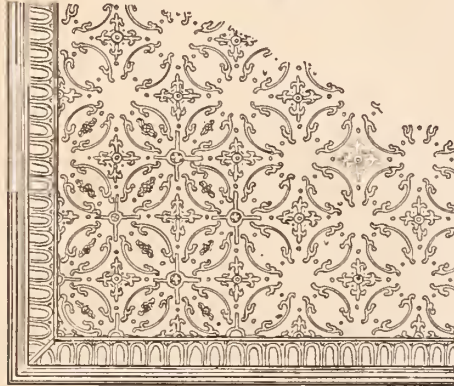

Easily applied in new buildings, and over old broken plaster or wood Ceilings. If interested in building or repairing, send stamp for Illustrated Catalogue, and state of **CHURCH, HALL STORE, OFFICE, SCHOOL** Ceiling is wanted. Address

**A. NORTHROP & CO., Pittsburg, Pa.**

**THE PHILADELPHIA COLLEGE OF HOROLOGY**  
A Practical School for Watch-Makers.

Most complete school of horology in America, elaborate outfit of appliances. Skilled and competent instructors. Jewelry work and stone-setting taught, also engraving. Send for prospectus.

**F. W. SCHULER & CO.,**  
No. 623 HEED BUILDING, PHILADELPHIA, PA.



61 Hanover Street, Boston, Mass.

Sales made for Jewelers only in their established places of business. Can give best references of any auctioneers in America.

All communications strictly confidential.

**HENRY ABBOTT,**  
MANUFACTURER OF  
Stem-Winding Attachments  
FOR WATCHES,  
No. 2 Maiden Lane, NEW YORK.

**The Other Side of Life.**

A HAIRY WATCH.

"I wish you would see what is the matter with this," said the customer, handing his watch across the showcase; "it has stopped. Perhaps there's a hair tangled up in the balance wheel."

The jeweler opened it, screwed his eye-glass into place and made the customary horrible grimace at the helpless watch. "A hair!" he said; "there's a lock of 'em."

"Well, give it a shampoo."—Chicago *Tribune*.

WHY HE WAS SAD.

His head had sunk upon his bosom and his attitude was of the conventional dejected variety.

The comforter stood beside him.

"Don't you believe," the messenger of love was saying, "that a watch is kept over you?"

The sorrowing, shrinking heart looked up. "Sir—"

He seemed very calm, indeed.

"— as to a watch I am uncertain, but I know there is a piano."

And even as they spoke an unseen hand in the flat above them struck nervously the chords to "After the Ball."—Detroit *Tribune*.



HEARD ON MAIDEN LANE.

Mrs. O'TOOLE (looking at men hoist a safe.)—Oh, my! Suppose thot rope they be haulin' it oop by should break!

Mr. O'TOOLE (disgusted at her ignorance.)—Phwist! Don't yez see thot three min hev a hold av it wid a rope at th' other ind?—Puck.

**THOMAS W. LIND, MANUFACTURER OF JEWELERS' FINDINGS,**  
67 FRIENDSHIP ST., PROVIDENCE, R. I.

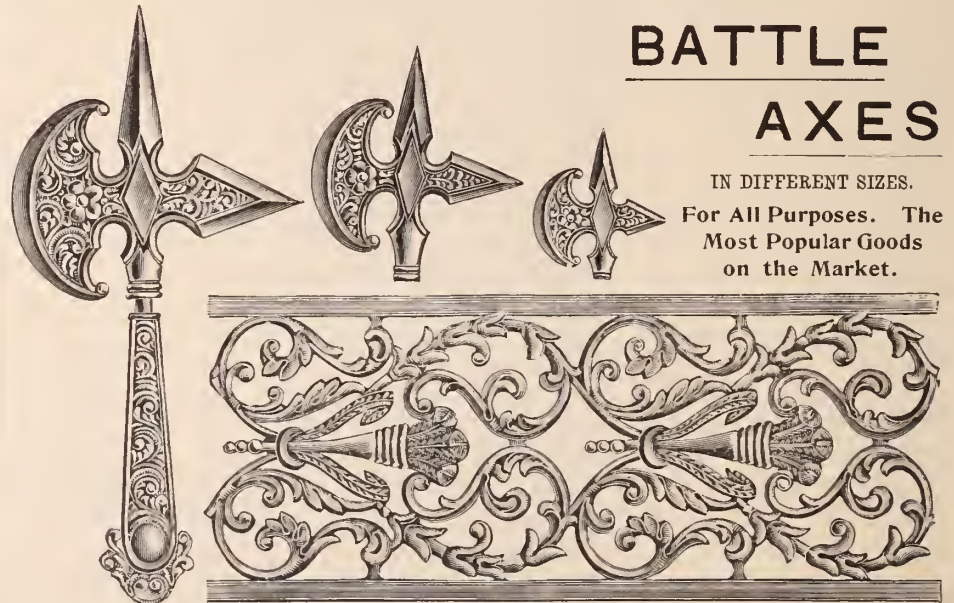

**BATTLE AXES**

IN DIFFERENT SIZES.  
For All Purposes. The Most Popular Goods on the Market.

THE LATEST ROCOCO—FULL SIZE.

Samples on Application—Write Us.

We Have Removed to  
**57 MAIDEN LANE.**  
**LEONHARDT & CURRAN,**  
MANUFACTURERS OF DIAMOND MOUNTINGS.



# HINRICHS & CO.,

29 AND 31 PARK PLACE,  
NEW YORK.

## BRIC-A-BRAC AND ART POTTERY.

**Belts** Send for Samples.  
**AND Buckles.**

Elegant designs. Prices as low as the lowest. Hair Pins, Link Buttons, Ladies' Combination Shirt Waist Sets and all the latest in **STERLING SILVER NOVELTIES.**

MANUFACTURED BY  
**CODDING BROS. & HEILBORN.**  
North Attleboro, Mass.  
Chicago office, Buck & Hall, 103 State St., Rm. 802.  
New York office, C. A. Vanderbilt, 178 B' way

Sold by all wholesale dealers at manufacturer's price.

**A. N. CLARK,**  
PLAINVILLE,  
CONN.

Manufacturer of the Celebrated  
**LOOP WATCH KEY.**  
The Best for the Price in the World.  
CROSBY'S JEWELING TOOLS IMPROVED.

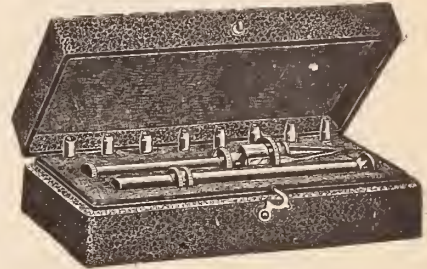
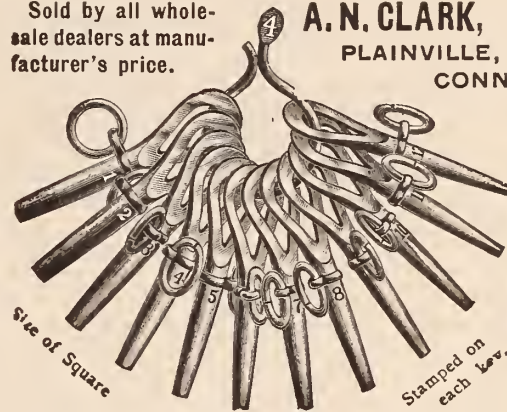

Will quote royalty or price for the manufacturing of articles of real worth.

**SAFES FOR JEWELERS.**

**MOSLER, BAHMANN & CO.,**  
518 BROADWAY, NEW YORK.  
Patent Fire and Burglar Proof Safes.



Large Assortment Always on Hand.  
Send for our Representative.  
Special Safes to Order.  
Jewelers' Safes a Specialty.

**FERD. FUCHS & BROS.**  
**SILVERSMITHS,**  
MAKERS OF STERLING SILVERWARE,  
808-810 Greenwich St., New York.

**G. A. WEBSTER**  
42 & 44 Madison St., Chicago, Ill.  
**Manufacturer,**  
AND WESTERN AGENT FOR  
E. G. WEBSTER & SON, of Brooklyn, N. Y.  
A. F. TOWLE & SON CO., of Greenfield, Mass

**SPECIAL**  
IN  
THE JEWELERS'  
CIRCULAR  
Produce the  
results desired.

**NOTICES**

## OPPENHEIMER BROS. & VEITH,

WATCHES AND



**DUEBER CASES, HAMPDEN MOVEMENTS.**  
AMSTERDAM, HOLLAND, 2 TULPSTRAAT. LONDON, ENG., 28 HOLBORN VIADUCT.  
NEW YORK, 35 MAIDEN LANE.



**WM. SMITH & CO.,**  
Manufacturers of Gold, Silver and Roll Plate Chains and Jewelry.



Novelties in Gold and Silver Bead Necklaces and Bracelets. Also a large line of Chain Trimmings and Silver Rings.  
Office: 5 and 7 Maiden Lane, New York.      Manufacturing: 61 Peck Street, Providence, R. I.





**Small Pearls.**

**M. D. ROTHSCHILD,**

NEW YORK: 41 & 43 MAIDEN LANE

LONDON: 15 HOLBORN VIADUCT

PARIS: 58 RUE LAFFITTE.

**HENRY FERA,**  
IMPORTER OF DIAMONDS  
AND DIAMOND BORTZ.  
Diamond Cutting and Polishing Establishment.  
10 Maiden Lane, NEW YORK.

For **BADGES AND MEDALS,**  
Flag Pins, Class Pins, Class Rings  
and Special Work of all Descriptions.  
SEND TO **E. R. STOCKWELL,** MANUF'R.  
19 John Street, New York.

**Rubies.**

**E. KIPLING,**

182 Broadway, New York.

ELEVATOR ENTRANCE, 2 JOHN ST.

**S. F. MYERS & CO.,**

WHOLESALE JEWELERS,  
MYERS BUILDINGS, - - NEW YORK.

1894 ISSUE, No. 38,

**OUR ROYAL CATALOGUE**

Illustrates all that is new, unique and desirable in  
everything that pertains to jewelry.  
Sent free to dealers who have not received it.

TWENTY-TWO DEPARTMENTS.  
SEVEN DOUBLE FLOORS.

Myers Buildings, 49-50 Maiden Lane,  
33-35 Liberty St., New York.

**WM. BIRMINGHAM & CO.,**

MANUFACTURERS OF  
All Kinds of Leather Spectacle and Eye Glass  
**CASES,**

728 Arch Street, PHILADELPHIA, PA.

**If Your Sales  
Are Not Satisfactory**

ADDRESS  
**DE B. O. SCOTT,**  
20 Murray Street, New York.  
AUCTIONEER.

Specialties: Watches, Clocks, Bric-a-Brad, &c.  
Write for particulars and references.

FRENCH ENGLISH  
CLOCKS AND HALL CLOCKS AND  
MATERIALS. MATERIALS.

**CHAS. JACQUES CLOCK CO.,** 22 CORTLANDT ST., N. Y.

**L. LELONG & BRO.,**

GOLD AND SILVER

**Refiners, Assayers and Sweep Smelters,**

◁ SOUTHWEST CORNER HALSEY AND MARSHALL STREETS, ▷

**NEWARK, N. J.**

**SWEEPINGS A SPECIALTY.**

**J. SCHAWEL & CO.,** 29 John St., N. Y.

GOLD & SILVER REFINERS, ASSAYERS & SWEEP SMELTERS.  
STERLING SILVER, 925/1000 FINE IN SHEET AND WIRE.  
Soft Platinum, Sheet and Wire for Manufacturing Jewelers.

**VACHERON & CONSTANTIN,**

GENEVA, SWITZERLAND.



FINEST QUALITY OF WATCH MOVE-  
MENTS, FITTING ALL SIZES OF  
AMERICAN CASES.

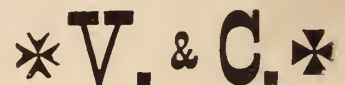

**EDMOND E. ROBERT,**

Agent for the United States and Canada.

21 & 23 MAIDEN LANE,

NEW YORK.

**ALBERT LORSCH & Co.,**

37 MAIDEN LANE, NEW YORK.

Branch, 167 Weybosset Street, Providence, R. I.

—♦— IMPORTERS OF DIAMONDS, —♦—

Rose Diamonds, Rubies, Sapphires, Emeralds, Opals, Moonstones,  
Fancy and Imitation Stones, Novelties.

SOLE OWNERS AND IMPORTERS OF

*The Sumatra Gem.*

REG'D.

UNEQUALLED IN  
BRILLIANCY AND  
HARDNESS

HIGHEST AWARD AT THE COLUMBIAN EXPOSITION, CHICAGO, 1893.

**IT PAYS** TO KEEP IN TOUCH WITH TRADE AFFAIRS.  
THE JEWELERS' CIRCULAR, For 4c. a Week will do it. **Subscribe.**

1869-1894=Twenty-five Years Oldest, Best Brightest, Newest=The Jewelers' Circular.















