

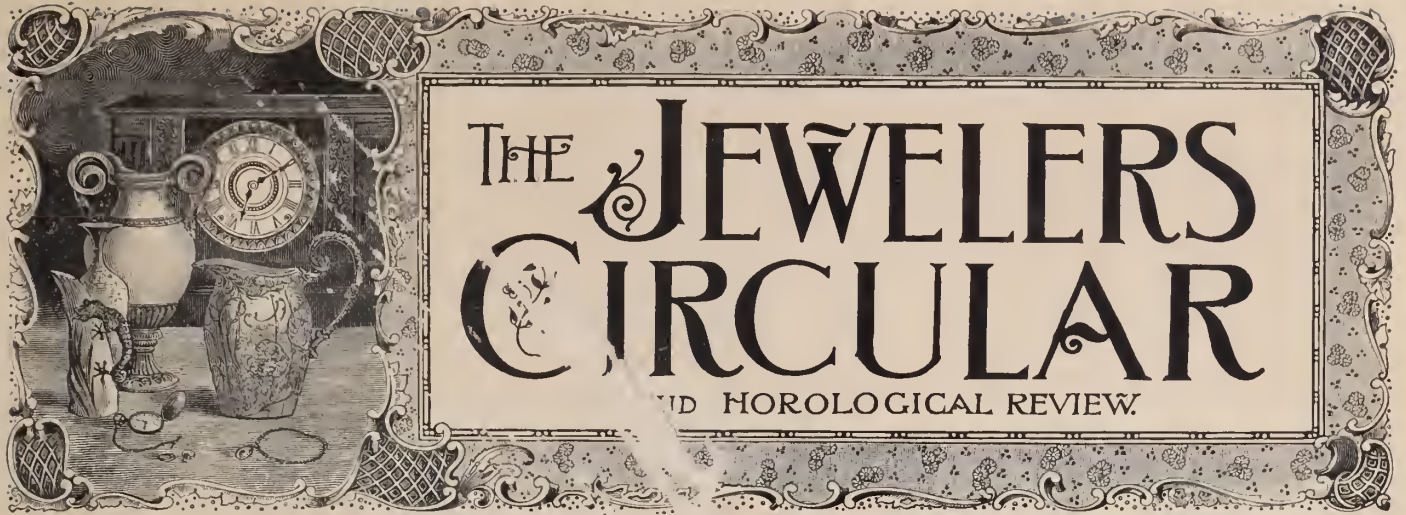

1875
1876
1877

1026



Entered at the Post Office in New York as second class matter.

VOL. XXII.

NEW YORK, WEDNESDAY, FEBRUARY 4, 1891.

No. 1.

OUR PRESIDENTS FOR 1891

WITH the advent of January came the annual conventions of the several organizations, of which the jewelry trade may well feel proud. The meetings of the Jewelers' and Tradesmen's Company, The Jewelers' League, The National Association of Jobbers in American Watches and the New York Jewelers' Board of Trade following closely upon the heels of each other, with the accompaniment of the second annual banquet of

showing the use of strength in each case; the Jewelers' and Tradesmen's Company and the Jewelers' League each have increased in membership, the membership of the Board of Trade has steadily augmented until to-day it numbers 138 individuals and firms; though the National Association shows a net loss of two, the honor manifested between member and member, and the unanimity of action of the combination have to-day made the Ameri-

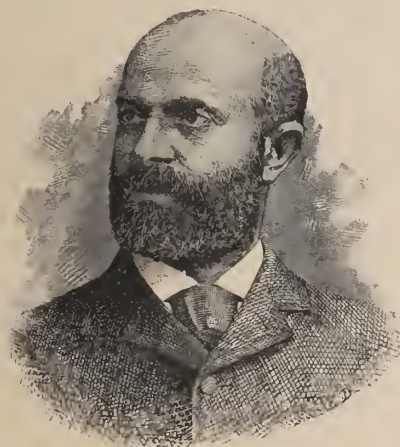

H. F. HAHN
President National Assn. of Jobbers.

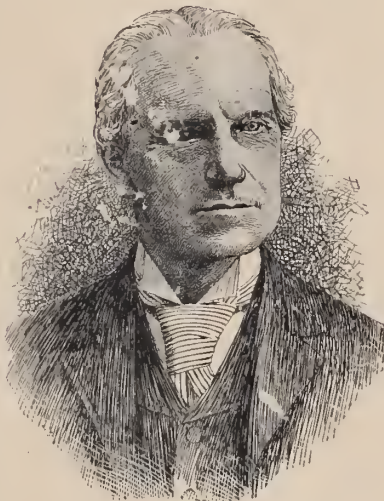

HENRY HAYES
President Jewelers' League.



L. J. SCOFIELD
President N. Y. Jewelers' Board of Trade.



GILBERT T. WOGLOM
President Jewelers' and Tradesmen's Co.

the latter organization, brought together in New York as large and representative a gathering of jewelers of the country as the city has perhaps ever seen. The curiosity manifested regarding the outcome of the half-secret meeting of the National Association was unprecedented; the banquet of the Board of Trade was a complete success; the meetings of the two insurance associations were well attended, all disadvantages of date and time of meeting being considered. The annual reports of the organizations

can watch business, as President Hahn says, an easy one, and the industry in fact the best in the country.

The accompanying portraits are of the presidents of these organizations. Among whom, Henry Hayes, of the League, Herman F. Hahn, of the National Association, and Edmund J. Scofield were re-elected at the annual meetings. Gilbert Woglom is serving the second year of his term, having been elected at the previous annual meeting for six years.

SOME REASONS WHY!

The Reason Why

the Spencer Optical Manufacturing Company are the most successful is because they manufacture everything they sell. The advantages of dealing directly with the maker are too well-known to make it necessary for us to explain, and it is convincing to shrewd buyers. This year we shall endeavor to eclipse any former attempts to supply customers with better goods and new goods at new prices. Our reputation for supplying goods which meet the wants of the trade and are with the times in every respect, to some extent explains the reason why our

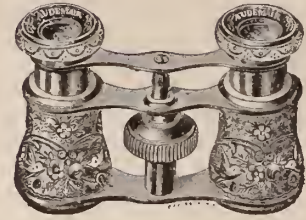

Optical Business

is increasing every year. Every year has eclipsed the previous one, and although the year that has just closed was the most successful of any in our one-third of a century of experience as manufacturing opticians,

1891

will undoubtedly be more so, as we were never better prepared.

Spectacles and Eye Glasses

in every desirable style and of every suitable material will be supplied more promptly this year than we have been able to do in the past. Our Descriptive Catalogues and Circulars are free. Send for them.

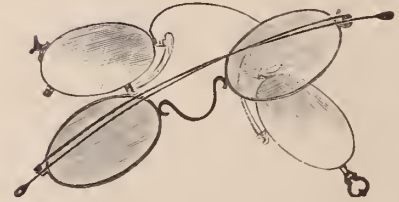

"Audemair" Oculists' Trial Cases

will, as in the past, be a strong feature with us. This case has made friends wherever shown because of its attractiveness, accuracy and low price. It is now in use in the consulting rooms of many of the best Ophthalmic Hospitals. The N. Y. Ophthalmic Hospital have had an "Audemair" case in use for some years, and showed how they appreciated it by ordering three more December 1st, 1890. Fifteen styles. Prices from \$36.00 to \$100.00, so we are sure to please you. Every purchaser will also be given a thorough course of instruction. If you haven't thought of getting an oculists' trial, it is time that you do; but when you do, don't get one until you have seen ours.



There was a man in our town,
Who was so wondrous wise,
He bought an "Audemair" trial case
To fit all kinds of eyes.

And when so well spectacles sold,
Said he, "it is quite plain
I'll sell them by the million
And get there just the same."

"Audemair" Opera, Field and Marine Glasses

Although the sales the past year were greater than any former period since their introduction, we are already preparing new designs and novelties for still greater sales in 1891. Customers should place their orders early and have their names on the eye piece.

ANYTHING in the Optical case can be obtained of us, and the QUALITIES AND PRICES will attract you. Send for our catalogues of Optical Goods, Ophthalmoscopes, Spectacles, Eye-glass Cases, Opera Glass Holders, &c., &c.,



The Spencer Optical Manufacturing Co.,
Manufacturing Opticians, 15 MAIDEN LANE, N. Y.

TRADE
SEAMLESS
 MARK.
GOLD · FILLED · CHAINS.

ON ACCOUNT OF

THE great popularity of the chains made exclusively by us for the past three years, the air has been FILLED and the paper of the various Jewelers' Journals COVERED with the word "SEAMLESS" which has been and is our trade mark.

We never had such a boom in our business as we have had since our friends commenced to advertise our goods.

We have only a word to add, and that is we make and sell the

ORIGINAL AND GENUINE
SEAMLESS GOLD FILLED CHAINS.

In addition to the word SEAMLESS and for the protection of our customers we place upon each Chain a tag bearing the following trade-mark:



Which is affixed by authority of its owners, as a guarantee that the Chains are made from the Burdon Seamless Filled Wire.

BOSTON OFFICE,

6 WINTER STREET,

In charge of

I. W. STELLE.

NEW YORK OFFICE,

17 Maiden Lane.

PACIFIC COAST AGENCY,

WM. E. PETTES & Co.,

PHELAN BUILDING,

SAN FRANCISCO, CAL.

Address all communications to

KENT & STANLEY,

PROVIDENCE, R. I.



A FESTIVE OCCASION.

SECOND ANNUAL BANQUET OF THE NEW YORK JEWELERS' BOARD OF TRADE.



RSTWHILE when the Roman and Greek gods and goddesses held high festivals, it was their wont to sit around on clouds and look at each other; they were clothed in little wings and ethereal graces, and their festivities consisted of quaffing wine from

golden cups, and sucking on oranges or other fruits. When Marcus Antonius returned to Egypt, where his love Cleopatra was pining away, there was such feasting in the halls of the Pharaohs as the "oldest inhabitant" had not seen; gold goblets were used for wine, and the viands were the choicest in the Orient, which we take it were fruit; at the close of the festivities the company made that famous excursion down the Nile we have all seen so accurately depicted in paintings and plates. When Rome was decaying and revelry held high carnival, banqueters intermittently sprawled themselves over couches, or walked about chatting politics while the slave carried the kid to the tune of the squeaky music from lyres played by other slaves; they also drank wine out of golden cups. When Schahzenan visited Schahriar, Sultan of Persia, as we are told in the Arabian Nights, the Sultan led the King into the garden where a splendid fête was served, the monarchs and favored courtiers sitting on sofas, while slaves stood about with plates of ragouts at which the guests made spasmodic grabs; other slaves poured wine from golden cups down the monarchs' and lords' throats. All these, and other high livers of whom history and tradition tell, enjoyed themselves hugely; it is queer, the brand of wine that was drunk is never specified. "Wine" seems to be all-comprehensive; as the world has progressed in everything, perhaps our present Perrier-Jouet and Lacrymi Cristi are ahead of the old ones. The gods, the ancients, the orientals dined generally as above. The New

York Jewelers' Board of Trade simply engaged the hospitality of Delmonico's for the evening of January 21st, and partook of a banquet which had taxed to its utmost capacity the ingenuity or the "art," as he would call it, of the *chef*.

The many happy banqueters will remember their glee when Col. Ingersoll, in his eloquent speech said: "I have no doubt but that there have been moments in my life when I was in the minority." Yes, the Board of Trade jewelers have had such mo-

time of their arrival at the hostelry, if not days, or even weeks before, and rapidly augmented during the evening until at the close, the humanity, the generosity and the love of mankind which overflowed each one's heart was depicted in his flushed and smiling face.

At about 6.15 the banqueters began to arrive, and knots gathered about in the waiting rooms chatting and laughing. Soon over two hundred men, well-dressed and handsome in presence, filled all the available stand-

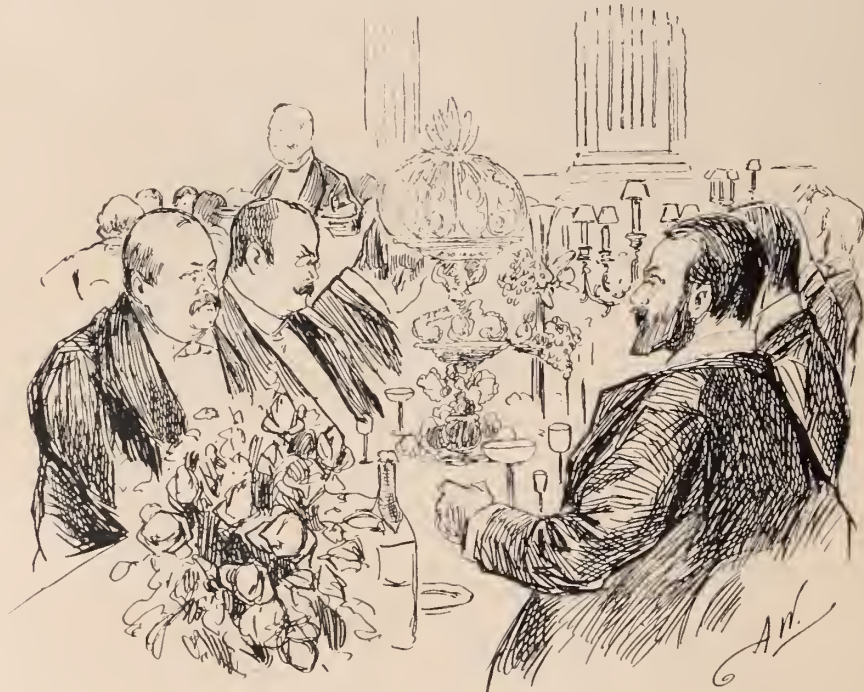

WINE AND CONVERSATION.

ments in their business life, when, for instance, their salesman have sent in, instead of orders, long rhodomontades upon the condition of the crops or the scarcity or frequency of rain. Yes, all have had their moments of minority, but not on the evening of Jan. 21; then the two hundred jewelers were in a very large majority, not only with themselves and their fellow craftsmen present, but with the entire world without, including the probable inhabitants of Mars and Jupiter. This feeling of satisfaction commenced at the

ing room. Some mindful of the comfort to others, in order to afford them more space for standing edged near to a table in one of the salons, upon which a bottle of wine stood. As each man arrived he seemed to hold an individual reception, so many were the well-wishing and hand-shaking friends he met. The reception committee were designated by a small red bow worn on the lapel. "What is the meaning of that bow?" asked a benighted soul of a member who is known to possess a facetious turn of mind. "It does not re-

THE PAIRPOINT MFG. CO.
New Bedford, Mass.

FINE
* GOLD *
AND
SILVER

Plated Ware.



OUR LARGE LINE
OF
STAPLES
AND
NOVELTIES

WILL BEAR INSPECTION.

Quality
Guaranteed.

No. 110. COFFEE SET.

NEW YORK.

CHICAGO.

SAN FRANCISCO.

FOR CLEANING AND POLISHING.

THE LATEST AND THE BEST
POLISH
FOR
SILVER, GOLD, NICKEL
AND GLASS.



WILL NOT SCRATCH
THE
FINEST SURFACE.

EVERY RETAILER OUGHT TO HAVE IT IN STOCK.



DAVID F. CONOVER & CO.

PHILADELPHIA, - - - - - PENN.

present the red rose of love; it means, 'Let's have one more.'" Upon the arrival of Col. Ingersoll, which was about 7:30 o'clock, the company, headed by the Reception Committee, and invited guests, marched into the banquet hall and seated themselves at tables in the following order:

At the officers' and guests' table, on the right of President Scofield, Rev. Dr. McArthur, of the Calvary Baptist Church, Joseph Fahys, ex-president of the Board; Col. R. G. Ingersoll, the celebrated lawyer, and Gurdon W. Hull, second Vice-President of the Board; on the left, Hon. Chas. A. Dana, editor of the *Sun*, Leopold Stern, first Vice-President of the Board, A. Herman, President of the Chicago Jewelers' Association, and the Hon. J. R. Brady, the well-known jurist.

TABLE B.—*Jewelers' Review Jewelers' Weekly*, *Jewelers' Circular*, *N. Y. Times*, *N. Y. Sun*, *N. Y. Tribune*, *N. Y. Herald, Press*, *N. Y. World*, W. F. Nye, W. J. Leavenworth, D. L. Safford, F. A. Wallace, G. M. Van Deventer, C. J. Dodshun, E. G. Miller, A. A. Webster, J. W. Miller, E. W. Martin, E. T. Willson, W. A. Copeland, Wm. Langdon, J. H. Hart, H. E. Oppenheimer, C. Jacques, M. E. Oppenheimer, N. Kauffman, S. Frankel, D. Gunzburger, J. Davidson, H. Z. Oppenheimer, S. Lindenborn, S. Wallach, H. M. Condit.

TABLE C.—F. E. Parsons, H. Dreyfus, E. P. Ellsworth, F. L. Smith, L. Stevens, Jr., S. Englander, M. Wood, A. Schwob, S. Blackinton, S. A. Rider, S. M. Hyneman, O. D. Wormster, W. B. Musser, E. Loesser, C. H. Brahe, C. A. Boynton, W. T. Woodruff, W. J. Miller, Seth E. Thomas, J. A. Lebkuecher, A. L. Brown, J. M. Lafferty, S. Avery, C. W. Sweet, H. H. Butts, A. Hodenpyl, J. H. Noyes, E. H. Cook, C. W. Harman, R. E. Burdick, F. M. Sproehule, F. S. Sherry, H. F. Cook, Ira Barrows, Geo. E. Fahys.

TABLE D.—J. M. Cutter, Benj. Allen, F. H. Hubbard, Henry Hayes, C. F. Kimball, L. W. Flersham, R. A. Kettle, A. M. Crommelin, J. W. Senior, C. R. Porterfield, A. B. Lounsbury, E. V. Clergue, E. F. Skinner, C. H. Smith, H. Untermeyer, D. Untermeyer, H. F.



COL. INGERSOLL.

"*Hope, hope—dear, blessed hope! The only universal liar that never loses its reputation.*"

Hahn, A. G. Schwab, E. Untermeyer, S. Aufhauser, J. Adler, H. Mayer, Sol Kaiser, J. Pohly, S. Blumauer, B. L. Strasburger, Reserved, M. A. Myers, T. W. Rockwell, N. J. Bach, E. S. Johnson, Jr., Geo. C.

Comstock, B. F. Einstein, W. F. Duncan, S. F. Myers.

TABLE E.—Isidore Stern, Aug. Goldsmith, E. K. Wright, Franklin Bien, G. M. Hard, S. Bergman, H. P. Doremus, A. Simon, I. Metzger, H. Kohn, M. Daniel, M. J. Lissauer, L. A. Sondheim, J. F. Lotz, H. S. Oppenheimer, W. B. Roberts, W. Bryant, A. Oppenheimer, H. F. Veith, D. F. Myer, S. Alling, G. L. Herzog, F. Welch, S. C. Howard, A. Frank, L. J. Mulford, B. Lowey, Mr. Rowbotham, S. H. Levy, T. H. Wheeler, I. W. Friedman, W. H. Fitzgerald, Louis Kahn, David Keller.

TABLE F.—H. L. Roberts, Otto Young, E. A. Eisele, C. N. Thorpe, J. L. Shephard, C. Hellebush, E. A. Whitney, C. M. Fogg, B. Thorpe, L. M. Sigler, N. H. White, Henry Ginnell, A. V. Huyler, B. Karsch, P. K. Hills, Jr., A. R. Johnson, I. Ettinger, F. Appleton Smith, G. W. Smith, W. S. Ginnell, D. N. Smith, F. R. Simmons, C. H. Knight, M. A. Mead, O. O. Stillman, J. T. Scott, Leo. Wormser, G. W. Washburn, F. L. Kelsey, Geo. Hutchinson, Irving A. Lewis, W. H. Atwater, W. Oskamp, J. S. Spenser, J. E. Spencer.

TABLE G.—Reserved, Jacob Groff, L. Weil, Joseph A. Kapp, E. De Roy, Jacob Kammerer, J. Koch, Adam Keller, J. B. Yates, Otto Graff, C. S. Dennison, H. K. Dyer, C. L. White, T. J. Fessenden, Geo. Kremeretz, D. C. Percival, Jno. N. Taylor, W. Paul, F. H. McProudfoot, J. S. Blake, O. A. Drinkwater, C. T. Morrell, M. Lilienthal, A. Paul, B. F. Rees, A. T. Sylvester, A. A. Kurtzborn, R. S. Hamilton, Jr., C. E. Mott, O. Heeren, W. A. Thompson, F. A. Frey, Haywarde Cozzens, A. T. Hubbard, J. C. Downing.

The Liederkranz Quartette, which proved a most interesting divertisement were stationed at the left of table G, near the foot. While the orchestra played that tune of welcome, "Ecce Quam Bonum," which anyone could see without any suggestion from a program, the diners enjoyed the beauty of the sight before: the splendor of the ball which dis-

The R. Wallace & Sons Mfg. Co.,



No. 230 CUP. IN STERLING SILVER, TWO-THIRDS SIZE.

MANUFACTURERS OF

Sterling Silver, Plated Ware & Fine Cutlery

FACTORIES, WALLINGFORD, CONN.

New York Store: 3 Park Place.
Chicago Store: 104 State Street.

closed in its architecture some of the finest Renaissance and Louis Quatorze decoration in the city was enhanced by the seven rows of high fine candelabra provided by the Pair-point M'fg. Co., the large decorative epergnes and other plate of the same make, the interspersions of large bouquets of flowers, bunches of foliage and dishes of fruit on the tables. Rev. Dr. McArthur offered prayer, at the close of which the army of Cruikshank—looking waiters brought in the viands, to which the company did full justice.

As good humor always follows in the wake of good eating, the individual and mutual satisfaction of the guests at the close of the repast was, if possible, greater than it had been. It was about 9 o'clock when the Boston contingency began to cause everyone to recollect that they did hail from the city of John L., Dr. Holmes and peculiar food. They became the drawing cards, the stars, a constellation in the firmament and they shed light about them without the co-operation of a moon, although there were two of them—at least some thought there were at the close of the dinner. When the orchestra recited the falls of McGinty, invited the audience to listen to somebody's tale of woe and informed the audience of the engagement of a surnameless Joe to Annie Rooney, the variety of voices which joined in chorus were many, though all were strong.

It was fully 9:30 o'clock when President Scofield, amid cheers, opened the exercises with the following brief address.

Gentlemen:—It is customary on occasions of this character to have an address from your presiding officer, but I have concluded to deviate from the common practice by curtailing my remarks to the smallest possible compass, not because I am insensible to the honor which is vested in me—the privilege of bidding you all a hearty welcome—but simply because an address from me of any length would only be robbing you of some of that wealth of eloquence which is now waiting on

such a large representation of our trade. The scene that here spreads out before me, growing in intensity and significance as the perspective increases, reveals a sight truly grand to look upon, and it is with feelings of no small emotion that I now, gentlemen, submit your attention to the tender mercies of the orators to follow, and heartily extend to you one and all a most cordial welcome.

The address was received with resounding applause; when this had somewhat subsided, the quartette tingled the souls of the banqueters with a stirring drinking song. The toasts were a model for all dinners. There were only six of them, and as that to the President of the United States was loyally drunk without response there were only five speeches. The consequence was that the speechmaking was almost dramatic in its activity, never allowing the enthusiasm to flag. The poetic mottoes which accompanied the toasts were from the pen of Stephen C. Howard & Son, Providence, and were all clever and bright compositions; they were as follows:

PRESIDENT OF THE UNITED STATES.

*To thee, great chief, a greeting glad we send;
You are our "Guide, Philosopher and Friend."*

THE GOLDSMITHS' ART.

*An art inspired by every other art:
Appealing to the mind, the soul, the heart.*

THE PRESS.

*A power, and one of "the powers that be,"
The freest thing in this land of the free.*

THE LADIES.

*If our souls were tossing now in the scorching
flames of Hades,
And we had one cooling drop, we would drink it
to the ladies.*

BENCH AND BAR.

*'Tis bar's exceptions, Bench's stay,
Accounts for much of law's delay.*

OUR COUNTRY.

*With tariff Byres or silver bands,
Forged by statesmen's blows;
Whether Ben or Grover fills the chair—"she
goes."*

who live even in Chicago. (More laughter, especially on the part of Boston.) And then he turned upon me when I made that last remark, and he transformed Tennyson's words: Better a cycle—how is it? (Colonel Ingersoll: "A year of Europe than a cycle of Cathay.") Ah yes; and he said,

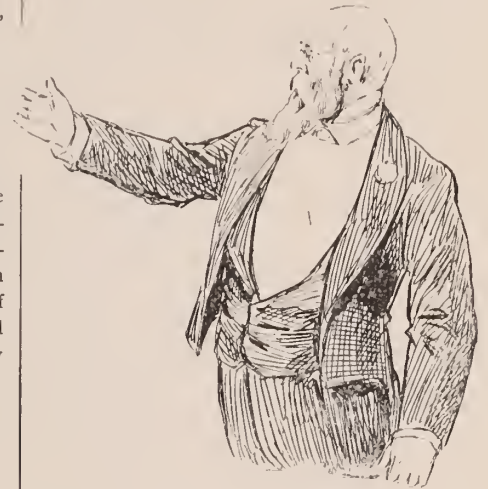

CHAS. A. DANA.

"I know that we would all of us like to have \$50,000 a year apiece, and the man who says he wouldn't and who won't admit that he'd rather have \$100,000 a year is a liar."

Better a year of New York than a cycle of Chicago. (Laughter and applause.)

Chas. A. Dana in replying to "The Press" continued the flow of wit and wisdom begun by the Rev. Doctor. Col. John R. Fellows was not present to respond to the stimulating sentiment to "The Ladies," and the President asked the assemblage to drink to them standing. Meanwhile, the Quartette sang the refrain "When a Maid loves a Man," and were happy. Judge John R. Brady spoke for the "Bench and Bar" and told some anecdotes, which though musty and hawthorn-covered, were very entertaining. Then followed the address of the night.

Col. Ingersoll's response to "Our Country" was as perhaps an eloquent address, as has been uttered at a Jeweler's banquet. Powerful in facts, eloquent in figures of speech, studded with flashes of the bright wit, the address drew the hearers out of themselves and kept them in a constant state of enthusiasm bordering on derangement. The pathos he is uttering in the engraving struck the audience with cannon-like force, and caused them to explode. The Boston and Chicago contingencies were made perfectly happy, if they had not been before by what the Colonel said in the course of his speech.

"Now," said he, "I have heard a little talk to-night about the various towns in the country, and among them about Boston, (laughter from all sides) and I want to give my testimony. * * * In my judgment there is no city beneath the shining stars, either on this hemisphere or the other, in which there is more genuine liberty of thought and expression than in the city of Boston. (Bostonians exultant.) I have a word to say about another part of this country that I am in love with, and that is Chicago.



THE BOSTON CONTINGENCY AT 9 O'CLOCK.

both sides of me to be uncorked for your delectation. It is no small satisfaction to the New York Jewelers' Board of Trade, to the members individually and to the body collectively, to see here assembled to-night

Rev. Dr. MacArthur responded to "The Goldsmith's Art." Among his many utterances that excited the risibilities of his hearers were:

"I have a boy who is just beginning to study the classics a little, and he came to me to-night to know who Midas was just as I was getting on my collar to come down here. I said: Midas! Why, I am going to see about a hundred of them to-night. They are the most wonderful men in the world. He said: Do they live in New York? I said Not all of them; a few of them, unfortunately for themselves, have to live in Boston. (Laughter.)

"But, he said, is there nobody else?" I said: "There may be a few of the name of Midas

(Chicagoans almost idiotized.) * * *
 There is an eagle with wondrous spread of wing rising in the West, and you look out if in twenty years from to-day Chicago is not the greatest city under the old flag. Look out! And there is a lot of energy in that city. I tell you you have no idea of it—the amount of business they will do there with a very few dollars. (Loud applause.) I have known a man in Chicago to buy a lot in the cemetery one-third down, the balance in two

or three years, and do \$100,000 worth of business the next year on his equity in that lot." (Laughter.)

At the close of the address the assemblage never thought they loved their country so well as they did, and all thought, and many expressed to their neighbors, that they lived in the greatest country existing, ever has existed or ever will exist. When "Auld Lang Syne" by the orchestra with a chorus from the assemblage closed the banquet, and each

man present felt that the eyes of the city were upon them, and that the Second Annual Banquet of the Board of Trade was the greatest affair of the greatest organization of the greatest trade in the greatest country.

High credit is due to the gentlemen who composed the Banquet Committee. M. D. Rothschild, chairman; J. C. Downing, S. F. Myers, David Keller, Geo. E. Fahys, and Jas. E. Spencer.

◆ DIAMONDS ◆

Our Diamond Stock in the future will be separated into twelve grades, as follows:

- A. Blue-White and Perfect.
- B. " " " Imperfect.
- C. Extra White and Perfect.
- D. " " " Imperfect.
- 1. White and Perfect.
- 2. " " Slightly Imperfect.
- 3. " " Imperfect.
- 4. Very Good Color and Perfect.
- 5. " " " Slightly Imperfect.
- 6. " " " Imperfect.
- 7. Good Color and Perfect.
- 8. " " " Imperfect.

Each piece in addition to the regular number will have one of these letters or numbers to indicate the quality of the diamond. This will give you the benefit of our judgment as to the grade and quality of each stone, and, we believe, will help you in the purchase and sale of diamonds from our stock.

Copyrighted August 15, 1890.

Copyrighted August 15, 1890.

When in need of anything special in diamonds, send to us for an assortment on selection. Don't hesitate because you may never have had any previous dealings with us, as we should be glad to have you for a customer—and to have you give this new grading system of ours a trial.

J. T. SCOTT & CO.,

4 MAIDEN LANE, * * * NEW YORK.

LEVY, DREYFUS & CO.

11 Maiden Lane,
NEW YORK.

Imperial Periscopic Spectacle Lenses

Rough or Beveled Edges.

Send for Sample of our

✧ INTERCHANGEABLE LENS, ✧

Centered, Accurately Focused, and
Beautifully Polished Surfaces.

KEY CHAINS.

ROBT. H. INGERSOLL & BRO.,

65 Cortlandt St.,

Send for List,

NEW YORK.



J. W. RICHARDSON & CO.

MANUFACTURERS OF

SOLID · GOLD · EMBLEMS,

Charms, Pins, Buttons and Badges,

194 Broadway, N. Y. City.

Our Illustrated Catalogue sent to JOBBERS on Application

JOSEPH JONAS.

JACOB DORST.

JONAS, DORST & CO.,

Manufacturing Jewelers and Importers of Diamonds.
169, 171 RACE STREET,

CINCINNATI, - - OHIO.

WE MAKE A SPECIALTY OF ALL STYLES OF

✧ DIAMOND MOUNTINGS. ✧

Society and School Badges,

FANCY MONOGRAMS and RINGS of all Descriptions.

We are prepared and have complete facilities for doing REPAIR WORK with neatness and dispatch.

DESIGNS EXECUTED FOR SPECIAL WORK.

We are the exclusive manufacturers of the celebrated Ophir Diamond Goods.



TRADE MARK

The Work of A Year.

The Fourth Annual Meeting of the Jewelers' and Tradesmen's Company.

President Woglum's Address—Reports of Officers and Committees—Officers Elected—An Important Amendment.

AT 5.45 of the evening of Jan. 19, the fourth annual meeting of the Jewelers' and Tradesmen's Company was begun in the pleasant rooms of the New York Jewelers' Board of Trade, 41 Maiden Lane, New York. Taking into account the peculiarities under which the annual meetings of this organization are held, the attendance was fair, the members present being as follows:

E. R. Smith, N. L. Cannon, R. E. Norton, Jr., J. C. Cottle, J. F. Simons, A. P. Jones, Jos. Schmidt, T. R. Creede, S. Cottle, J. A. Smith, D. M. Fisher, R. Banse, E. S. Johnson, Jr., Thos. A. Young, G. T. Woglom, W. L. Copeland, T. L. Parker, S. W. Saxton, and L. W. Sweet.

According to the schedule of business, the reading of the minutes of the last annual meeting was first in order. Vice-President Thos. A. Young moved to suspend the procedure. The motion was carried and so ordered.

Introductory remarks by the president being next in order, President Gilbert T. Woglom, read the following:

PRESIDENT WOGLUM'S ADDRESS.

To the Members of the Jewelers' and Tradesmen's Company:

GENTLEMEN:

We feel a sense of gratitude to THE JEWELERS' CIRCULAR, *The Jewelers' Weekly*, and the present *Jewelers, Watchmaker and Silversmith* (formerly *The Jewelers' Catalogue*) for the space so freely granted for the dissemination of monthly information as to the growth of our association, and would heartily express that gratitude in precedence of all other matters.

The succinct reports of our secretary and treasurer, combined with those of our board of directors and executive committee, which will be presented to you at this meeting, will show you a gratifying record in the steady increase of our membership, the considerable increase in our reserve fund and the still larger amount which our combined contributions have enabled us to pay to the beneficiaries of our deceased members during the fiscal year ending December 31, 1890.

It is a pleasure to say that the attendance of our officers to their duties has been cheerful, faithful, exact and performed in the utmost harmony.

On December 16, our board of directors voted to close on that date the charter roll of members, all of whom became members without admission fees, and thereafter, without exception, to require the admission fees. These latter enable us to show substantial appreciation of the efforts of our charter members in procuring others, and is a profit to our old members by the contrasting fact that our new members will be required to pay fees which were waived to our earlier members.

We promised last year that we would cease promptly you to procure other members. We shall now and hereafter keep that promise, trusting to the efforts of such of our members and others as may become voluntarily interested in our work and growth. You may now, even in life, rest in peace.

Now that we have secured a business home and have closed our charter roll, we feel sanguine of a rapid filling up of our membership to the point of paying our certificates in full. The recent action looking toward this, in conjunction with an improvement in our system of assessments, which has been urged upon us almost

with importunity by many of our members, and which will be presented to you for your concurrence at this meeting, will undoubtedly hasten the consummation so devoutly wished for by us all.

Our Board of Directors need no apology for recommending the enactment of the proposed amendment to our constitution. Though it was deemed inexpedient in another form a year ago, it is now, after the lapse of another year, deemed the proper time for it in its present form. We shall be alert for any other timely improvements in the interest of our association.

We have been so frequently asked what our insurance will cost, and to explain and justify our system of assessments, that it will not be amiss to discuss them briefly at this time, in order that our members may the better know, and themselves be able to justify their faith in our system. A life insurance association on any plan must provide for the payment by its constituents of the amounts requisite for paying its death claims, plus expenses of management. The latter are rigidly limited and defined and segregated from the death fund in our company. The former can as readily be defined by an analysis of the sworn records of the largest two insurance companies, now, and for forty-eight years, in existence in this State. The records are for twenty-eight years, beginning with 1859, when they were first required to make sworn reports. They show that the average sum required for meeting the death losses at all ages, is less than \$12.00 per thousand per annum. The reports of six or eight companies other than the two indicted, verify that figure, while the returns made by over thirty other companies during the lapse of thirty years, indicate an average cost for all ages of less than \$11.00 per thousand per annum. We thus see that \$75.00 to \$85.00 per annum would be the maximum cost and expense of carrying a \$5,000 membership, with no probability of exceeding such limit. If these facts, collated from reliable statistics, do not define the cost, then life insurance is but a game of chance, the actuaries have wasted years of scientific research, and the records of our insurance department of the State of New York are but waste paper. The records justify, and the premises lead to the conclusion that the average of our insurance will require the payment per annum of not over \$85.00 for \$5,000.

An actuary well known in this city has written of assessment insurance: "The natural common sense plan would be to pay each year for the cost of insurance actually furnished during that year, including suitable margin for expenses, and to guard against adverse contingencies, such as an epidemic." A pamphlet entitled "Co-operative or Assessment Life Insurance, its History and Prospects," written by an able actuary and published in the interest of old style insurance companies, to show the ephemeral character of level or uniform assessment societies, says: "Assessments graded according to age at entrance, and increasing each year according to mortality tables, or assessments remaining the same and benefits decreasing as the death rate increases, is the only just form of co-operative insurance."

The mortality table system, by which our members contribute each his share toward the total sum per annum required to meet current death losses, is as scientifically certain to adjust each payment according to the respective ages of each of our members, as we are sure of the fact that a man at fifty years of age is twenty years nearer to his death than he was at the age of thirty. If the requirements of any assessment company per annum exceed \$85.00 for \$5,000, it is because the assessments are not equitably adjusted to the varying ages of its members: because negligent in the selection of its members, or because it is using the proceeds of its mortuary assessments for other than the payments for deaths. But no properly conducted, equitably rated assessment company can reach a mortality to require for \$5,000, \$85.00 per annum until it has been in existence years enough for the original members who approximated the maximum limit of age at entrance, to have reached the end of their lives; in other words, until the range of the ages of its members is defined by respectively the minimum age at entrance and the average maximum age at exit by death. During the fifteen or twenty years after organizing and before the mortality reaches the normal rate for a body of men varying in their ages from twenty-one to say seventy-five years, the cost will be much less than \$85.00, and that due to the advantages of selection and the average youth of members.

While this maximum of \$85.00 is being gradually approached, we should feel well satisfied because we have cast our lots and our efforts for each other in an association which so equitably adjusts the assessments for the varying ages, that the increased mortality of the older men will be paid by themselves as required by the aging feature of our assessments.

In a large company in Pennsylvania, which assesses on the level system, their experience for nine years has been tabulated, showing the ratio of lapsing members to the whole number received between the given ages as follows:

AGE WHEN ADMITTED.	RATIO.
21 to 25.....	56 per centum.
26 " 30.....	46 " "
31 " 35.....	36 " "
36 " 40.....	42 " "
41 " 45.....	23 " "
46 " 50.....	8 " "
51 " 55.....	5 " "
56 and over.....	5 " "

That is, of those who joined between the ages of twenty-one and twenty-five, fifty-six per centum dropped out, and as the ages increased the percentage steadily decreased to the oldest, and of these only five per centum dropped.

Wisdom comes with age; that ninety-two per cent. of men above fifty, and that ninety-five per cent. of men above fifty-five knew a good thing when they saw it. These old codgers were getting their insurance for one-third of its actual cost, and the young men, in addition to paying for themselves, were paying for the other two-thirds that the old men did not pay. It is not to be wondered at, therefore, that fifty per cent. of the youngsters dropped out. Young men cannot be attracted readily into joining upon the same rates as old and impaired risks. If they are so attracted they are repelled in the ratios given. If the young pay too much and the old too little, the young desert and leave the old to sink the society by the weight of years and accompanying mortality. On the contrary our graduated and aging feature of assessing will hold old and young, each beside the other, each knowing that he is paying no more, no less, than the cost of his insurance at his own age.

Our vitality, our longevity, does not depend upon new members alone. They are conserved by the aging feature of our assessments. Life insurance, like fire insurance, from year to year, with the privilege of renewal and continuance during life, without medical re-examination.

Some have asked "What is the secret of the Jewelers' and Tradesmen's Company's growth and success?" Well, there is no secret about it. Its advantages in equity are self evident, its plan is modern, its cost can never be burdensome, it conforms to the requirements of all classes—it is "just a success."

Vice-President Young here arose and suggested that the report of the meeting be printed in full and copies distributed to the members. It was decided to do so.

Secretary E. S. Johnson, Jr., then read the Medical Director's Report, which was as follows:

REPORT OF THE MEDICAL DIRECTOR.

Mr. Gilbert T. Woglom, President, and the Jewelers' and Tradesmen's Company.

DEAR SIR AND GENTLEMEN:

I respectfully report that to January 1, 1890, the total number of examinations and supervisions was as follows:

Examined and supervised.....	940
Approved.....	891
Declined.....	49— 940
Since that report and to January 1, 1891, one year, I have examined...	57
Approved.....	52
Declined.....	5— 57
Reports of the medical examinations supervised.....	65
Approved.....	62
Declined.....	3— 65
Total number of examinations and supervisions for the year.....	122

★ ROGERS & BRO. A-1.

OLDEST BRAND MADE.

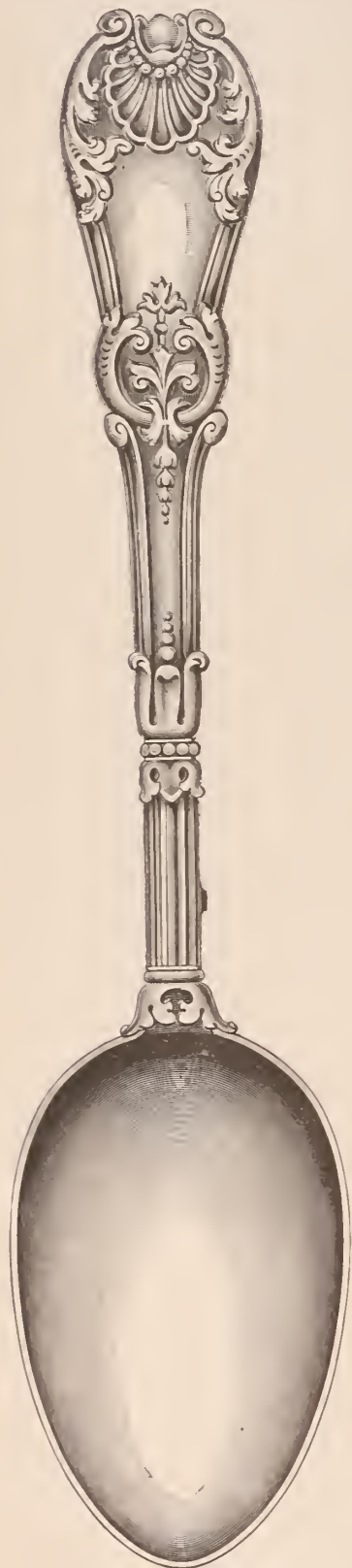

NAME COPYRIGHT GRANTED.



DESIGN PATENTED.



THE "TUXEDO."

WE INVITE attention to our NEW PAT-
TERN, illustrated here, which for
massive richness, grace of outline and
general artistic excellence is unsurpassed,
and which we feel assured will meet with
the approval of the trade.

ROGERS & BROTHER, WATERBURY, CONN.

Manufacturers of the Highest Grade Electro Silver Plate,
16 CORTLANDT STREET, NEW YORK.

Approved 114
 Declined 8 — 122
 These added to the number in my last report make a total of examined and supervised 1,062
 Approved 1,005
 Declined 57 — 1,062
 All of which is respectfully submitted,
 CHAS. F. ROBERTS, M.D.,
 Medical Director.

New York, January 19, 1891.

Vice-President Young moved to adopt the report and place it on file. The motion was carried and so ordered.

Secretary Johnson then read his report, which was next in order:

THE SECRETARY'S REPORT.

To the Officers, Directors and Members of the Jewelers' and Tradesmen's Company.

GENTLEMEN:

I have the honor to respectfully submit the following report for the year ending December 31, 1890.

AMOUNT OF INSURANCE WRITTEN.

Amount January 1, 1890..... \$2,680,500
 Amount written during the year..... 491,500

Amount December 31, 1890..... \$3,172,000

AMOUNT OF BENEFIT WRITTEN AND BENEFIT IN FORCE.

	Amount Written.	Amount in Force.
Amounts January 1, 1890.....	\$2,433,000	\$2,243,500
Amount written during the year.....	441,500	441,500
Amount reinstated during the year.....		94,000
	\$2,874,500	\$2,779,000
Amount of benefit reduced.....	8,000	
Terminated by resignation or otherwise.....	401,000	
Terminated by death.....	25,000	
	434,000	434,000
Amounts Dec. 31, 1890.....	\$2,874,500	\$2,345,000

EXHIBIT OF CERTIFICATES ISSUED AND IN FORCE.

	Issued	In Force
Totals, January 1, 1890.....	839	780
Issued during the year.....	132	132
Reinstated during the year.....		27
	971	939
Terminated by resignation or otherwise.....	125	
Terminated by death.....	6	
	131	131
Totals, December 31, 1890.....	971	808

EXHIBIT OF APPLICATIONS.

	Received.	Approved	Rejected.	Advised to Withdraw.
Totals, January 1, 1890.....	923	875	36	12
From January 1, to December 31, 1890.....	147	134	13
Totals, December 31, 1890.....	1070	1009	49	12
Applications received.....				1,070
" approved.....	1,009			
" rejected.....	49			
" advised to withdraw.....	12			
				1,070

AVERAGE AGE.

Average age of the members admitted in January is 41
 " " " " " Febr'y " 39
 " " " " " March " 38
 " " " " " April " 40
 " " " " " May " 40

Average age of the members admitted in June " 38
 " " " " " July " 43
 " " " " " August " 34
 " " " " " Sept'her " 38
 " " " " " October " 40
 " " " " " Nov'her " 41
 " " " " " Dec'ber " 40

INCOME.

For annual dues during the year..... \$5,209.49
 For assessment on new insurance in 1890..... 597.92
 " from mortuary calls in 1890... 14,560.58

Total receipts from the members in 1890. \$20,367.99

Amount received for mortuary purposes since organization..... \$24,059.97
 Twenty per cent. placed to reserve fund..... 4,811.99

Interest received from U. S. Trust Co..... 149.74

Paid for death losses..... 15,950.92

Less amount paid for mortuary call No. 3, in process of collection, less the 20 per cent. deducted above for the reserve fund..... \$388.10

Amount of contingent mortuary fund, Dec. 31, 1890..... \$3,058.70

The report was adopted and placed on file.

Before the reading of the treasurer's report, which was next in order, President Woglom said that in compliance with the suggestion made at the last annual meeting to have the treasurer's accounts audited before they were submitted to the next meeting, the services of an experienced accountant had been engaged; but owing to personal circumstances stated in a letter read by the president, the former had been unable to fulfill his part. Vice-president Young moved that, in justice to the secretary and treasurer, the report be not printed until the accounts were audited. The motion was carried.

Secretary Johnson then read

THE TREASURER'S REPORT.

NEW YORK, January 1, 1891.

Assets of January 1, 1890.

Mortuary fund balance..... \$3,275.60
 Reserve " " 1,780.29
 Annual dues fund balance..... 202.41
 Interest account..... 43.79

Assessments for mortuary purposes, Jan. 1, 1890, to Jan. 1, 1891..... 15,158.50

20 per cent. to reserve fund... \$3,031.70

80 per cent. to mortuary fund. 12,126.80

\$15,158.50

Interest received from U. S. Trust Co., Jan. 1, 1890, and transferred to mortuary fund. 105.95

Amount received for annual dues for year..... 5,209.49

Amount received for interest from U. S. Trust Co..... 95.16

Gross assets..... 25,871.19

Disbursements for 1890, mortuary calls 3, 4, 5, 6 and 7..... 12,105.34

General expenses..... 5,168.90

\$17,274.24

Net assets..... \$8,596.95

Mortuary fund balance is... \$388.10

Contingent fund balance is... 2,853.70

Reserve " " " " " 4,811.99
 Annual dues fund balance is... 448.00
 Interest account..... 95.16
 \$8,596.95

Placed as follows:

United States Trust Co..... \$6,506.71
 Chatham National Bank..... 1,097.16
 In hand..... 993.08

\$8,596.95

S. W. SAXTON,

Treasurer.

This report was adopted and placed on file.

The next business in order was the reading of the reports of the Boards of Directors and the Executive Committee, which were embodied in one statement.

REPORT OF THE BOARD OF DIRECTORS.

To the Members of the Jewelers' and Tradesmen's Company.

It is again a pleasure to your Board of Directors to greet you at this fourth annual meeting of our company, and bid you a cordial welcome.

This meeting is to consider and give special attention to the work of our company in the year just closed, and to discuss the work for the future. The reports rendered by your officers present so fully the details of the business of the past year that but little remains for us to say. At the beginning of the year 1890, the Reserve Fund amounted to \$1,780.29, and on December 31, 1890, it amounted to \$4,811.99, making an increase for the year of \$3,031.70.

During the year there were ten meetings held by the Board of Directors. The Executive Committee, upon whom devolves the duty of passing upon the applications and proofs of death, have held forty-two sessions during the year, in which they approved 134 applications and rejected thirteen.

A year ago we carefully considered the matter of quarterly assessments, and at that time we reported adversely. However well justified we may have been a year ago, we are equally well justified at this time in presenting the matter in a much better form to meet our requirements. We approve of the periodical plan of assessments, rather than the arbitrary quarterly assessments. The periodical plan will equalize and average the assessments as may best meet the convenience of the members, and conform that convenience with a varying mortality. The present proposition is to amend as follows:

"In order to provide for the prompt and speedy payment of death claims, the Mortuary Fund shall be contributed to by assessments periodically made upon the members, at such intervals as may, in the judgment of the Board of Directors, best conserve the interests of the member.

"All sections or parts of sections in conflict with this provision of the Constitution are hereby repealed.

"These provisions shall take effect immediately."

Our success is assured. Our growth is an index of appreciation of our efforts to supply what the intelligent man seeks; namely, insurance at cost. With the united interest of all your members, seconded by the exertions of your officers, with honest, economical, and wise management, our growth will be as sturdy as it is rapid. It costs money to carry life insurance, no matter on what plan, or in what company or association it is carried; and the sooner insurers cease deluding themselves or allowing others to delude them with the idea that insurance can be secured for a mere nothing, no matter who promises it, the sooner will they appreciate the efforts of a company that furnishes insurance at exact cost and with a consequent certainty of permanence.

Also submitted as Report of the Executive Committee.

THOS. A. YOUNG,
 CHAS. F. ROBERTS, M.D.,
 SAMUEL A. BALDWIN,
 GILBERT T. WOGLOM,
 SAMUEL SONDEHEIM,
 JAMES A. SMITH,
 E. S. JOHNSON, JR.,
 SAMUEL W. SAXTON,
 CHAS. A. FOWLER,
 THOS. R. CREEDE,
 JOHN C. DOWNING,
 SHUBAEL COTTLE.

(Signed),

"PRINCES and Kings desired it long, but died without the sight."

MORE POPULAR THAN EVER.

"BRYANT" INITIAL RING.

Patented May 12, 1885.



In its numerous styles, most easily interchangeable, handsomest and best. In elegant Trays of Six or Twelve, with extra Initials, PREFERRED TO ALL OTHERS!



EVERYTHING IN
Fancy Stone and Other Styles of Rings.
 FOR SPRING TRADE.

S. W. Saxton moved to adopt this report. Before submitting the report of the subcommittee of the Finance Committee, President Woglom explained that that committee had nothing to do with the general expenditures of the organization, but only controlled the transfer of money from the banks and trust companies back to the members. The report which was afterwards adopted and placed on file, was then read.

REPORT OF FINANCE COMMITTEE.

NEW YORK, Jan. 19, 1891.

To the President and Board of Directors of the Jewelers' and Tradesmen's Company of New York:

GENTLEMEN:

Your Finance Committee report the following transactions for the year ending January 1, 1891.

Balance on hand in U. S. Trust Co., Jan. 1 1890.....	\$4,710.94
Amount deposited in U. S. Trust Co., April 25, 1890	3,700.00
Amount deposited in U. S. Trust Co., August 7, 1890	1,000.00
Amount deposited in U. S. Trust Co., August 25, 1890.....	2,500.00
Amount deposited in U. S. Trust Co., October 16, 1890.....	5,000.00
Amount deposited in U. S. Trust Co., November 17, 1890.....	1,500.00
Add to the accumulated interest on deposits to October 17.....	201.11
	<hr/>
	\$18,612.05

JAS. A. SMITH.

President Woglom then called attention to the fact of the increase of \$3,000 in the reserve fund during the past year. This fund, he said, was not piled up to be looked at as a child's plaything, but was to be divided eventually among members. It was gathered in case of an excessive death rate.

President Woglom then read a short communication which Mr. Young moved to receive. There was no unfinished business.

The election of officers was next in order. The terms of Vice-Presidents Thos. A. Young, Charles F. Roberts, M.D., and Samuel A. Baldwin expiring, these gentlemen were unanimously re-elected, the Secretary casting one ballot for each.

The proposed amendment to Article V (Sec. 2) of the constitution specified in the Board of Directors' Report, was next argued. President Woglom relinquished the chair to Vice-President Young, and taking the floor, spoke in favor of its adoption. He said that the average annual mortality of the organization is from two and a half to three per cent.; that although but six assessments were made last year, the small number was owing to the decrease of average death rate during the year before, or the decrease of the probable death rate of the coming year. He claimed that periodical assessments would prove more convenient to the members than spasmodic assessments, on the theory that it is apparently easier to pay a small amount at stated periods than to allow these amounts to accumulate and then pay in bulk.

Theodore L. Parker requested Vice-president Young to speak. He did so, forcibly advocating the adoption of the measure and referring to the success of the Mutual Reserve Fund Association, which enforced the same

1891.

THE MIDDLETOWN PLATE CO.

MIDDLETOWN, CONN.

MANUFACTURERS OF

Superior Silver Plated Ware.



WE SHALL offer for the ensuing year a largely increased variety of STAPLE and FANCY GOODS. We solicit the attention of the trade.



No. 25. BRUSH SET.

MILITARY BRUSH TO MATCH.

THE MIDDLETOWN PLATE CO.

SALESROOMS: { 22 John St., New York, 113 to 115 State St., Chicago, Ill.,
118 to 120 Sutter St., San Francisco, Cal.

Weiss & Oppenheimer,

Artistic Gold Cases

In 14-K. Only.



"HENRIETTA."

16 Size, Design 308.

192 Broadway, New York.



system of assessment. He said that the assessments would probably not exceed four in number.

Mr. Parker, though favoring the adoption of the amendment, expressed his anxiety concerning the possible action of the Board of Directors who, in consequence of regular business obligations and lack of sufficient investigation, might make the number of assessments far beyond the ability of the members to pay. His anxiety on this point was allayed by Mr. Young, who saw that, as Chairman of the Board, he would exert his influence to keep the number down to four. President Woglom closed the discussion with some forcible remarks, comparing the company to an arch, and the mutual confidence of the members to the keystone. The motion was then put to the meeting and the amendment was adopted.

There being no further miscellaneous business, the meeting adjourned.

They Mark Time's Flight.

THE arrival of the new year brought to THE CIRCULAR the usual courtesies from many of its friends. Among the mementos welcomed at our office are the following:

S. C. Jackson, manufacturer of jewelers' cases, trays and kindred paraphernalia, No. 180 Broadway, has distributed among his friends and patrons a neat little pad calendar. The red figure date-mark is striking and easily read. On the leaves are printed carefully selected quotations from well-known authors; and if everyone were committed to memory and applied to business life, there would be more Solons than ever among the jewelers of the country.

As attractive as the Company's wares are the pretty faces of two girls represented on the calendar sent by the Pairpoint M'fg. Co., of New Bedford, Mass. The girls are pictured in the act of snowballing, and the good will that always accompanies these missiles from gentle hands is intended by the Pairpoint Company to accompany their souvenir.

Like a warm breeze from the sunny East comes the face of an Oriental beauty portrayed on the calendar souvenir of H. Z. & H. Oppenheimer, No. 48 Maiden Lane. The jewelry worn by the fair girl is handsome in appearance and the whole design is neat and tasty.

A handy memorandum pad calendar is that of G. & S. Owen & Co., No. 3 Maiden Lane.

You cannot jot down a mem. for any day in the year without observing that this house has presented you the calendar with its compliments. It is a constant reminder.

A beautiful steel engraving of the familiar picture of a battle between two stags is the most attractive feature of the calendar for 1891 presented by the New Jersey Lamp and Bronze Works, of New Brunswick, N. J., whose salesroom is at No. 91 Duane Street, this city. It is an ornament to any office wall.

Carter, Sloan & Co., No. 15 Maiden Lane, intend that their friends shall remember them every day in the year. To the accomplishment of this, their pad calendar, with the name of the firm on every leaf, is a very effective agent. It is very handy with its stiff back, and may be hung upon a nail or stood up against the back of your desk to tell you what day it is and where to buy good goods.

Randel, Baremore & Billings, No. 58 Nassau Street, have packed a calendar that will do service for both 1891 and 1892 in a neat black leather-covered envelope with open front. It may be hung up inside of your desk; and when 1891 has become but a memory, you need only reverse the cards in the envelope and a new face looks out through what has by this time become an old friend—the black envelope.

Erhard Bissinger.

THE friends of Mr. Erhard Bissinger, United States Consul to Beirut, Syria will be pleased to know that he is improving in health and is now able to attend to his consular duties. Mr. Bissinger will be remembered as a genial, whole-souled man, popular among the jewelers in this city.

The subjoined is an extract from a letter recently received from Mr. Bissinger by Mr. A. K. Sloan, of Carter, Sloan & Co.

"My own health, much enfeebled of late years by sickness and the cares of official life, has slightly improved, thanks to a change of air and absolute respite from the cares of my office during a temporary leave of four months absence, from which I have recently returned, much benefited."

MAXHEIMER & BERESFORD,

MANUFACTURERS OF

FINE DIAMOND JEWELRY,

No. 3 Maiden Lane, New York.

ORDER WORK A SPECIALTY.

AMERICAN WOOD STAINING WORKS.

SYSTÈME AUFFERMANN.

Black Veneers and Boards
Stained through and
through.
Imitation of Mahogany, Oak
Cherry, Cedar, Etc.

SILVER GRAY BOARDS

AUFFERMANN & CO.,



Modern Fancy Colored
Veneers, Plain and Figured,
specially adapted for
Jewelry and Silverware
Cases.

A SPECIALTY.

211 E. 42d Street, N. Y.



A CASE NOT IN COURT

SETTLED WITHOUT A JURY.

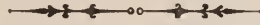

The Witnesses in the Case

are the thousand of well-pleased and more than satisfied customers who have selected out of our sample rolls for themselves or friends the fine rolled plate chains, also the **KING FILLED and SEAMLESS** chains which we have made for a number of years.—

The King Filled Seamless Chains

and the $\frac{1}{4}$ plate chains are the best—none better. We place upon them our personal guarantee for Twenty Years!—

The Witnesses.

that is, our customers, have also testified by buying again and again that
Square Dealing

Honest Goods and

Low Prices

determine the verdict every time.

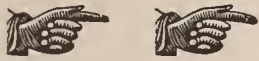

Here is another case (not a chain soldered with gold solder but a *Seamless Chain*). If you were to bring it into court we believe the judge would decide without giving it to the jury in these words: "It is impossible to convey an accurate idea of a seamless chain by a written description."—

Ingenious Make

A seamless chain is of _____ and must not only be seen but worn to be thoroughly appreciated. There is not one person in a thousand who can form a correct idea or opinion of a seamless chain until he has tried one.—

Bear in Mind

that the mere word "seamless" is simply descriptive, that it cannot be adopted as a trade-mark and that it can be used by anybody.—

We know of no

14-karat seamless chain in the market except in the **KING FILLED SEAMLESS**. This is fully and absolutely guaranteed by the well-known and reliable registered trade mark
★ H. & H. —

HAMILTON
&
HAMILTON, JR.,
Providence, R. I.

192 Broadway & 111
John St., New York.

We put up our reputation of twenty-one years as business men, that we never advertise anything we cannot do, and do honestly and squarely. We would like to have both your friendship and custom; but if we cannot have both, let us have your custom, and we feel sure that your friendship will follow.—

Endorsed by the Retailers



Of the Entire Country.

NOTICE!

If the trade desire the **BURDON WIRE** in preference to the **SEAMLESS WIRE** of our own make, we will gladly furnish it.



Our New Year's Greeting to the Trade.

THE LATEST PARISIAN NOVELTY!



A Remarkable Imitation of the Natural Grape in a choice variety of
BROOCHES, LACE PINS, DROPS, SCARF PINS, ETC.



In Bracelets



WE OFFER A NEW AND EXCEPTIONALLY FINE LINE.

→ The General Character of all the Goods shown is of a High Standard of Excellence. ←

CROSSIN & TUCKER,
409 PINE STREET, PROVIDENCE, R. I.

The Jewelers' League.

The Fourteenth Annual Meeting, at Masonic Hall.

President Hayes' Address—Prosperous Condition of the Organization—The Half-Rate Membership Question Settled—Reports of Various Committees.

About one hundred and thirty-five members of the Jewelers' League, of the City of New York, assembled in Masonic Hall, corner of Sixth avenue and Twenty-third street, New York, on the evening of January 21, to attend the fourteenth annual meeting of that organization. The attendance was hardly so large as was expected, but the interest and enthusiasm manifested during the entire session by those present compensated in a measure for the lack of attendance.

The interest centered in the proposed amendment to the Constitution given at length further on in this article, and the reading of the report of the special committee appointed at the last annual meeting to devise a plan for a half-rate membership in the League. In addition to these matters, reports of the officers and the Executive Committee were presented, and elections held for President for a term of one year; two vice-presidents, known as the third and fourth vice-presidents for a term of two years, a secretary and treasurer for one year, three members of the Executive Committee for two years and three members of the Advisory Board to serve two years.

Among the members present were the following:

W. H. Jenks, S. P. Snow, E. R. Ferris, M. J. Enno, B. W. Ellison, B. N. Buell, F. W. Von Berner, C. F. Egler, F. P. Benedict, A. W. Sexton, W. L. Sexton, G. W. Washburn, R. Schneider, E. H. Brown, A. E. Lavigne, J. H. Johnston, J. Rosset, T. Lesperance, G. T. Wogioni, H. A. Valentine, T. Rosenthal, J. B. Bowden, M. L. Bowden, L. J. Mulford, J. W. Beacham, J. Strauss, A. W. Woodhull, J. Obrey, C. G. Brown, J. Rothschild, H. J. Henze, C. W. Bridgman, W. E. Moutoux, W. Heller, C. A. Gallagher, Geo. H. Houghton, H. Untermeyer, D. Untermeyer, E. H. Eckel, C. G. Lewis, L. W. Sweet, Wm. Bardel, J. R. Gleason, E. F. Keppler, J. B. Mann, L. Stevens, L. S. Lewis, C. A. Boynton, C. Van de Sande, F. E. Tiffany, A. A. Jeannot, E. F. Randoiph, W. R. Jackson, L. Bonnet, O. Cæsar, W. J. Kreil, G. W. Book, A. H. Jacot, J. W. Fahr, F. Hoyt, C. McBride, S. Cottle, J. M. Todd, C. L. White, S. Preston, Jr., J. J. Lynch, N. J. Tommen, G. A. Hollis, J. R. Scofield, S. F. Levy, J. C. Mount, R. S. Hamilton, Jr., S. B. Kent, J. R. McAllister, Sol. Bergman, B. H. Blank, S. Aufhauser, T. W. Manchester, H. W. Heller, J. H. Burnett, A. M. H. Bonnet, W. S. Durand, H. A. W. Goll, J. J. Sommer, C. D. Harire, J. Y. DeMoll, C. F. Pierce, F. A. Drerding, G. R. Schofield, A. W. Page, C. J. Theuerner, Otto Heeren, Henry Hayes, A. Herman, A. Kurtzborn, A. G. Schwab, E. V. Clegue, Howard, J. W. Senior, Mr. Settle, C. J. Fox, Theo. Parker, C. C. Champenois, H. D. Sherrill, G. W. Vandeventer.

The meeting had been called for 7.30 o'clock, but it was fully 8 o'clock when the members were called to order and business was begun. President Hayes asked the committee of five which had been appointed to formulate a half-rate membership amendment, to adjourn into a room at the right of rostrum. Upon motion, the reading of the minutes of the last annual meeting was dispensed with, since they were already in the

hands of the members in printed form. President Hayes then rose and read the following address:

THE PRESIDENT'S ADDRESS.

With greetings we assemble on the threshold of another year to celebrate our fourteenth anniversary. With just and proper pride, with true gratitude and satisfaction, we cast our glances back over a pleasant vista, marking the steady progress made by our institution, with many a token of the joy shed upon aching hearts that otherwise would have been crushed by the dread shadows of loneliness, helplessness and penury. Had we been only almoners of gifts instead of disbursers of money prudently provided by the forethought of discretion and by the promptings of affection, would we not congratulate ourselves on the existence of the League? Would we not feel that we had received more than equivalents were nothing further to be gained.

But, however bright the past, we have before us a brighter future. The history of half a generation, with its experiences and its satisfaction, has no brighter spot than the circle of the past twelve months. The obligations of the vast majority of our members have been met, the self-denials of many men have been devoted to maintaining their standing on our roll, and while a few have fallen under a burden greater than was anticipated at the outset of the journey, yet our roll of associates shows a substantial increase, with a corresponding advantage of financial strength. It is unnecessary here to enumerate the details, for they will appear in the reports of your officers and committees; suffice it to remark that we have never legislated more wisely than in adopting the provision for quarterly assessments, a source of yearly substantial accretion to our reserve fund, without a perceptible increase of burden upon each member. Yet why should that be called a burden which, combined with all our dues, has not cost us one-half the amount required in any life insurance company to pay so large a benefit? It is not burdensome to contribute to our mutual advantage in an enterprise which is so honestly and economically administered, for we pay only the mere cost of the beneficence.

During the past year nothing of note in our history has occurred calling for especial remark. The felicitous monotony of honest, steady, unflinching labor has been pursued unmarked by any diversion from the path of progress. One subject has been under consideration during the year to which reference may be made. I refer to the work of the committee to which was committed the subject of half-rate membership. This committee was named to formulate a plan which would "in nowise jeopardize the interest of the present members, afford exact equity to all concerned and insure additional financial strength." They deserve our thanks for having devoted many hours of care and thought to their work, which work they have done well; so that it is no immature result that will be placed before you this evening.

Permit me to say that so important a measure should receive most earnest and careful consideration. The three problems involved are very comprehensive and far reaching. First, we must "not jeopardize the interest of the present members." These interests are held very dear to a vast body of men living in every part of our land. Wherever one travels he is certain to meet our associates and these are almost universally the best types of substantial, thoughtful business men. They respect the standing and great work of the League. Its welfare is woven into the very fibres of their social and business life. They support it for its untarnished record; they have implicit faith in its integrity. They have a conservative dread of disturbing what is already strong, lest a radical change should introduce an element of weakness, and many of our most substantial members would be prompted to resign, without waiting to see the workings of an untried experiment, though that experiment should ultimately prove beneficial.

Next, we are to devise what would "insure additional financial strength." This is no minor factor to be dealt with. We have slowly acquired a reserve, which already is abundant strength, as also a basis of confidence, and unless the scheme shall unquestionably add too and not detract from it we shall not conserve the third problem before us of affording "exact equity to all concerned."

In thus expressing my views I do not wish to be understood as opposing any wise plan for half-rate membership, for many of you well know that my sympathy has always been and now is with such plans as would satisfactorily accomplish the object of enabling very many worthy men in our trade to procure a benefit, which, under our present order, they cannot honestly assume to provide for. These men would be as loyal to their obligations as are our present members, and we must be as just to the new class as to the old, because we might unconsciously legislate unfavorably to them; therefore we must be cautious in making a change. Can we not provide a plan that shall be in a degree experimental, which, when proven to be sound and equitable, may intuitively and healthfully be grafted on our present organization to the mutual advantage of both, and thereby form an institution well rounded in symmetry, large in its comprehensiveness and widespread in its beneficial results? It is better to commit an error of prudence than one of over-zealousness. We must be sure of our path; we must not grope in darkness, lest we take a false step which cannot be easily retraced.

At the risk of tedious repetition, you will allow me to express the great obligation due by every one of us to the entire executive committee for the care, sacrifice of time and attention given our interests. These gentlemen serve us as faithfully as they attend to their own personal affairs. They serve without pecuniary reward but rather to their pecuniary disadvantage. Impartiality, thoroughness and prudence govern all their labors for us. Their only reward is the satisfaction of a conscientious discharge of duty. Neither will I omit to mention the perfectly satisfactory manner in which our secretary and treasurer transacts the multitude of business coming hourly before him and his corps of faithful assistants. The accurate and simple methods of routine work must commend themselves to the examining committee, as they did to the Insurance Department of our State, which voluntarily eulogized, the perfection of the entire system pervading the affairs of the office.

When the applause which greeted the address had subsided, the President called for the reading of the report of the Examining Finance Committee. As Henry Dreyfus, E. E. Kipling and Edward Livingston, composing this committee were absent, the President called upon J. R. Gleason to read the report in their stead. On motion the reading was dispensed with, since it also was in possession of the members. It is given here with:

REPORT OF FINANCE COMMITTEE.

The undersigned have examined the books and accounts of the Jewelers' League, and find them correctly set forth in the treasurer's report. They also find that the bonds as specified are deposited in the deposit vaults in the Nassau Bank.

HENRY DREYFUS,
E. E. KIPLING,
EDWARD LIVINGSTON,
Examining Finance Committee.

The next business in order was the hearing of the report of the Secretary and Treasurer. The reading also was dispensed with on the same grounds as the others. Following is the

SECRETARY'S AND TREASURER'S REPORT.

Membership.....	2,750	
Reserve fund.....	\$113,825.78	
Amount paid to beneficiaries since date of organization...	856,050.70	
Number of members, Jan. 1890..		2,721
Applications received during year 1890.....	200	
Applications rejected during year 1890.....	6	194
		2,915
Members who have died.....	25	
Members who have been dropped	140	165
Present membership.....	2,750	

mount on hand January 21, 1890.....		\$16,604.14
<i>Receipts.</i>		
194 Members' initiation fees at \$3.00.....	\$582.00	
194 Members' first assessments at \$2.00.....		388.00
55 surplus assessments of members at 50c.....	27.50	
52 surplus assessments of members at \$1.00.....	32.00	
19 surplus assessments of members at \$2.00.....	38.00	
Amount from reinstatements.	2,218.50	
Interest on deposits.....	94.40	
Interest on contingent fund...	4,090.00	
Interest on permanent fund...	335.00	
Amount received from "Jewelers' Security Alliance," toward expenses of general agent.....	205.00	
Assessments numbers 153 and 154 ..		10,763.00
Assessments numbers 155 to 159		26,598.50
" " 160 to 163		21,381.00
" " 164 to 168		26,254.50
" " 169 to 173		26,463.00
" " 174 to 176		15,915.00
" " 177.....		5,429.50
Amount from quarterly dues.	10,679.00	
	\$18,301.40	\$149,796.64
<i>Disbursements.</i>		
Beneficiary of W. S. Richardson, New York City.....	\$5,000.00	
Beneficiary of R. A. Johnson, New York City.....	5,000.00	
Beneficiary of B. F. Pierce, Erie, Pa..	5,000.00	
Beneficiary of Geo. J. Landes, Brooklyn, N. Y.....	5,000.00	
Beneficiary of Geo. L. Ford, Boston, Mass.....	5,000.00	
Beneficiary of Geo. W. Royce, New York City.....	5,000.00	
Beneficiary of J. F. Piper, Orange, N. J.....	5,000.00	
Beneficiary of S. D. Mills, Kansas City, Mo.....	5,000.00	
Beneficiary of Jas. Thomson, New York City.....	5,000.00	
Beneficiary of Isidor Weil, New York City.....	5,000.00	
Beneficiary of Alex. B. Clark, Cincinnati, O.....	5,000.00	
Beneficiary of B. Hebrank, Wheeling, W. Va.....	5,000.00	
Beneficiary of J. Dinkelspiel, San Francisco, Cal...	5,000.00	
Beneficiary of Wm. Daue, New York City.....	5,000.00	
Beneficiary of J. Fricker, Americus, Ga.....	5,000.00	
Beneficiary of T. H. Kortum, Shreveport, La.....	5,000.00	
Beneficiary of H. S. Bedell, Newark, N. J.....	5,000.00	
Beneficiary of Alb't Schuette, Chica'o, Ill.....	5,088.00	
Beneficiary of Chas. Pfennig, Macon, Ga.....	5,000.00	

Beneficiary of A. H. Meyerhoff, New York City.....	5,000.00	
Beneficiary of Wm. Herrick, Paris, France.....	5,000.00	
Beneficiary of W. L. Brice, Lima, O..	5,000.00	
Beneficiary of B. H. Stief, Nashville, Tenn.....	5,000.00	
Beneficiary of C. Scherer, Lexington, Ky.....	5,000.00	
Beneficiary of Solomon Bauman, St. Louis, Mo.....	5,000.00	
Beneficiary of L. L. Deniville, Geneva, Switzerland.....	5,000.00	
Purchase of bonds during year 1890..	16,487.53	146,575.53
Amounts carried forward.....	\$18,301.40	\$3,221.11
Amounts brought forward.....	\$18,301.40	\$3,221.11
<i>Miscellaneous Disbursements.</i>		
Books, stationery and printing....	\$764.00	
Postage and rent of P. O. Box.....	603.17	
Rent of office, 170 Broadway.....	400.00	
Rent of hall for annual meeting....	40.00	
Furniture for office.	182.53	
Gas, ice, and office expenses.....	151.10	
Fees of attorney, \$150; Examiner, \$58.....	208.00	
Fees of medical examiner, \$46.25; actuary, \$10.....	56.25	
Stenographer, annual meeting, \$5; sundries, \$45.....	50.00	
Rent of safe deposit vault.....	10.00	
Salary and traveling expenses of gen'l agent.....	2,759.85	
Commission of secretary, 3½ per cent. on \$136,090.50....	4,763.15	9,988.05
		8,313.45
Balance.....		\$11,534.46
Amount received on current assessm't.	\$4,832.50	
<i>Board of Trustees.</i>		
	Par value.	Cost.
Permanent Fund.—N. Y. City and County 6 per cent. bonds.....	\$3,500.00	\$4,733.82
Permanent Fund.—N. Y. City and County, 5 per cent. bonds.....	2,500.00	3,272.94
Contingent Fund.—N. Y. City and County, 5 per cent. bonds.....	2,000.00	2,284.61
Contingent Fund.—N. Y. City and County, 6 per cent. bonds.....	57,000.00	73,916.03
Contingent Fund.—N. Y. City and County, 7 per cent. bonds.....	13,500.00	18,083.92
	\$78,500.00	\$102,291.32
	Wm. L. Sexton,	Secretary and Treasurer.

The undersigned have examined the books and accounts of the Jewelers' League, and find them correctly set forth in the Treasurer's Report. They also find that the Bonds as specified are deposited in the Safe Deposit Vaults in the Nassau Bank.

HENRY DREYFUS, } Examining
E. E. KIPLING, } Finance
EDWARD LIVINGSTON. } Committee

NEW YORK, January 20, 1891.

Geo. R. Howe then read the report of the Executive Committee, which was received with prolonged applause.

THE REPORT OF THE EXECUTIVE COMMITTEE.

The executive committee are glad to report that congratulations are again in order. The year just closing has been prosperous and, notwithstanding the large number of deaths in the first part of the year from la grippe, the death rate for the year has been low. While we have lost many members by failure to pay their assessments, our agent has been able to secure new ones, not only to supply the places of all that had dropped, but to give us an increase of twenty-nine members for the year. Our Reserve Fund has increased, as the treasurer's report shows, and the guaranty of payment of future death losses is proportionately increased.

Your committee have met regularly and given careful consideration to all that pertains to the welfare of the League. They now desire to repeat the recommendation offered for several years past, that members should be more careful about paying their assessments promptly. The secretary has no option, but must drop from the roll all members from whom he has received no remittance the time of closing an assessment, and members are often left without insurance for two and three weeks at a time, even after their money has been received at the office of the League. When a name is dropped the member cannot be reinstated until a meeting of the committee is held, and then it is optional with the committee to reinstate or not. A large number of lapses are from carelessness. Should such a careless member die after being dropped and before being reinstated (even though the funds were in the treasurer's possession) your committee would have no power to assess the members for such death. Therefore, each succeeding committee for years has endeavored to impress upon the membership the duty not only of paying but of paying promptly, and at the risk of being tedious your present committee would emphasize this recommendation and the following one to members not able to pay a heavy assessment at sight.

Lay aside regularly each month enough to provide for the average annual assessment: by the close of the year; do not overlook the fact that sometimes for months at a time no death occurs, and then several occur within a short time. If the entire number of deaths in any one year, say twenty-five, should occur in a single month, it is the duty of each member to provide for prompt payment, just as much as though two or three deaths had occurred in each month. Our League is purely mutual. Each member pays the simple cost of insurance and holds in his own possession a large part of what would be the reserve fund of a regular life insurance company, because much larger assessments would be paid, and each member is in honor bound to hold a part of his individual reserve ready for immediate use. Please also remember the duty that rests upon you to send in the names of new members yourselves and to assist our agent, Mr. Jones, to secure desirable members.

Your committee hereby tender their thanks to the secretary and his associates, our board of examining surgeons, our council, and the trade journals, as well as to the membership. All have co-operated to make the record of the past year.

J. B. BOWDEN }
CHAS. G. LEWIS, }
JAS. P. SNOW, }
JOHN R. GREASON, }
WM. BARDELL }
DAVID UNTERMEYER, }
W. H. JENKS, }
G. H. HOUGHTON, }
A. A. JEANNOT, }
GEO. R. HOWE. }

The election of officers was next in order. President Hayes called J. B. Bowden to the chair. He met with the enthusiastic applause that usually greets that gentleman upon

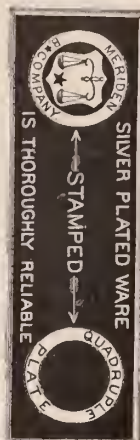

MERIDEN BRITANNIA CO.

MERIDEN, CONN.

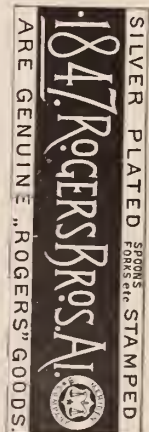

GOLD AND SILVER PLATE.

NEW YORK,

SAN FRANCISCO,

LONDON,

CHICAGO,

HAMILTON, ONT.

PARIS.

SPOONS AND KNIVES.

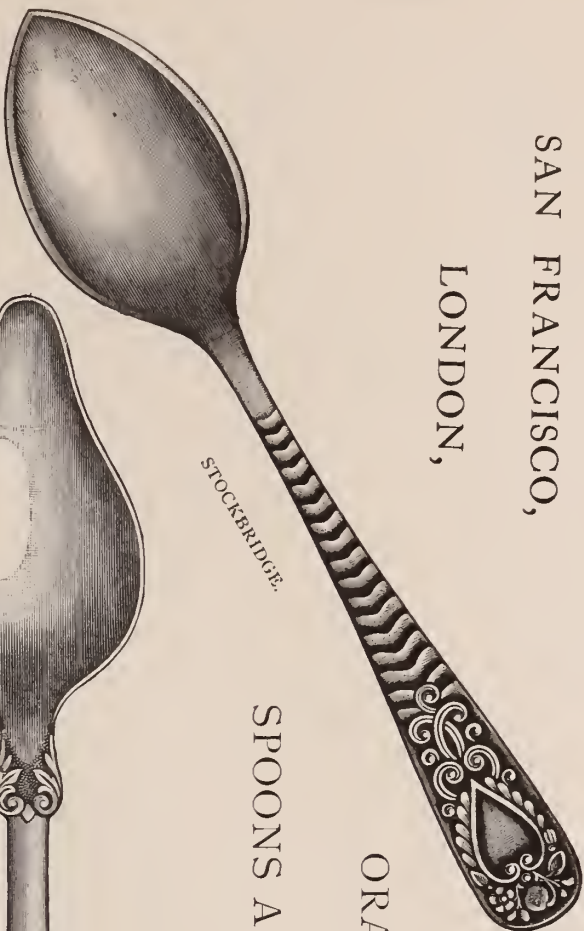

STOCKBRIDGE.

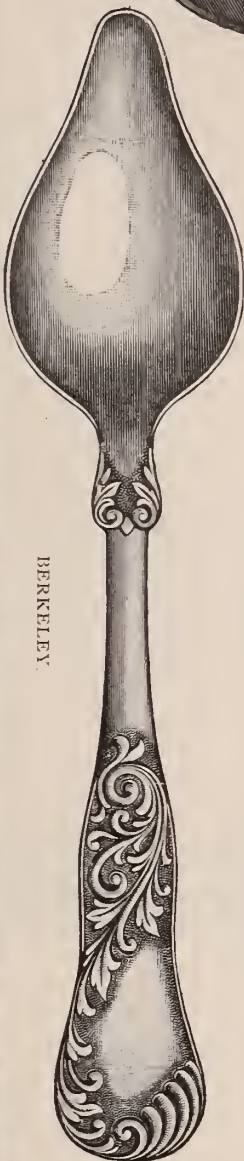

BERKELEY.

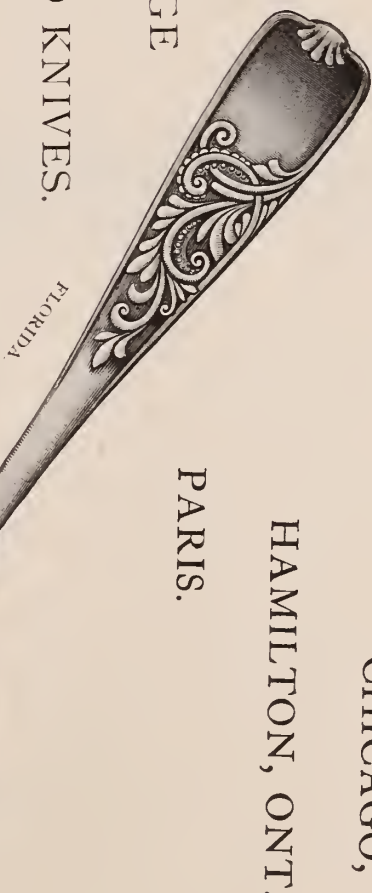

FLORIDA.

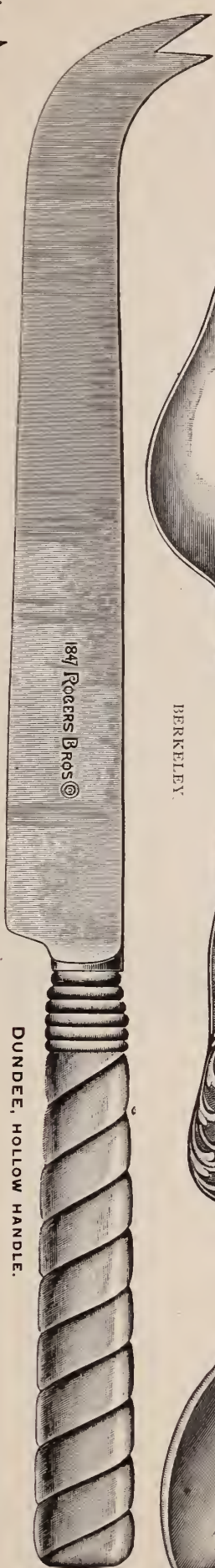

DUNDEE, HOLLOW HANDLE.

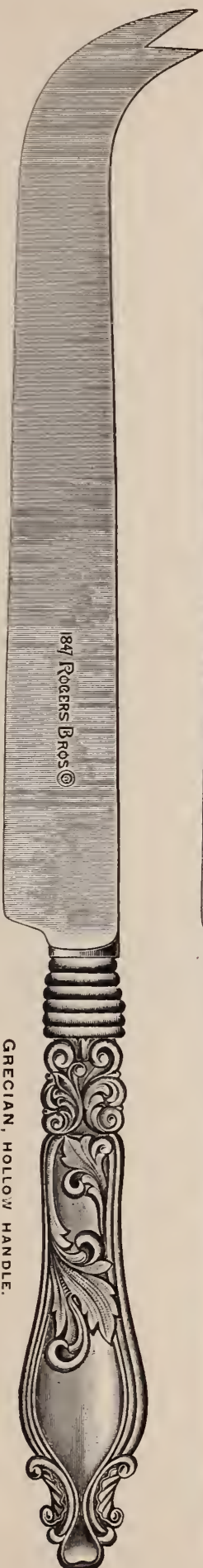

GRECIAN, HOLLOW HANDLE.

1847 ROGERS BROS. CO.

1847 ROGERS BROS. CO.

F. & B.

LET THE FIGHT GO ON. The war between SEAMLESS and GOLD SOLDERED CHAINS will prove one of two things, either Seamless Wire is as good as Gold Soldered, or Gold Soldered is as good as Seamless.

A Dutchman offering a horse for sale was asked if the horse had the heaves. "I don't know," said the Dutchman, "but if de heaves are goot for de horse, de horse got 'em." If "Seamless" or "Gold Soldered" is good for chain, we've got 'em or can get 'em. We are making an honest, well finished chain of such good soldered wire that the seam cannot be found, and one that will wear ten years. The whole question is, who puts gold enough on their wire to make a good wearing chain? Some do and some do not. We make a finely finished chain of good, heavy, gold plated wire. Our chain will wear for ten years. We put our stamp on them which is a guarantee that the goods are right. The ten year chains.

Call for our Solderless Locketts, made from stock that is as hard as it comes from the rolls, no solder used and the stock is hard and smooth.



THE WASHINGTON BRACELET.

Our "Washington Bracelet" is one of historic value. It shows a fine medallion of Washington, dates of his birth and death, dates of service as President, his seal, the original flag, his coat of arms and crest (from which was conceived our national flag), and the names of the thirteen original states.

We make a large line of Locketts and Charms, Chains in Vests, Dickens and Victorias, Neck Chains, Bar Pins, Jersey Pins, Stick Pins, Initial Scarf Pins, Initial Bangles, Chain Mountings, Bracelets, Garters, Interlocking Glove Buttoners, Bead Necklaces and Earrings.

FOSTER & BAILEY,

PROVIDENCE, R. I.

his stepping upon the platform. A. Kurtzebom nominated Henry Hayes, and the latter was unanimously elected for the — time, the secretary casting one ballot. A. Herman and A. Kurtzebom were called to the stage to announce the result of the election. The members out-jeweler's Leagued themselves in applause.

Mr. Hayes, in accepting the old trust, said that he had formed the bad habit of renewing the confidence which the members placed in him, and that an expression of his appreciation would prove wearisome. But he assured the assemblage that if he could serve them in the future as he had endeavored to do in the past, he would not be displeased. For third Vice-President, A. Herman proposed C. G. Lewis. The latter, however, withdrew in favor of J. B. Bowden, who was unanimously elected, A. G. Schwab and Otto Heeren acting as tellers of the single ballot cast by the secretary. Mr. Lewis was unanimously elected Fourth Vice-president in the same manner. Henry Untermyer had been nominated by Jacob Strauss, but that gentleman declined the honor. Prolonged applause greeted the result of both elections. President Hayes called the four vice-presidents to the platform, James P. Snow, John R. Greason, J. B. Bowden and Chas. G. Lewis. He then announced that there was to be an election of an entirely new secretary and treasurer which somehow struck the assemblage facetiously and excited their risibilities to a vociferous extent. J. W. Senior nominated W. L. Sexton as a man who had "served the League faithfully for a good number of years," and asked the president to cast one ballot. "After a spirited contest," announced the latter, "W. L. Sexton is unanimously elected." This announcement struck the audience in the same manner as the former one. Mr. Sexton in a few remarks of gratitude and good humor accepted the honor which has so repeatedly been bestowed upon him. Wm. Bardel, David Untermyer and Geo. H. Houghton were unanimously re-elected members of the Executive Committee on the nominations of J. W. Senior, A. Herman, J. W. Beacham, respectively. A. Herman and A. Kurtzebom acted as tellers of the single ballots cast by the secretary.

E. H. Brown moved that the secretary read the proposed amendment in relation to the all-absorbing question—the admission of half-rate members. It was as follows :

PROPOSED AMENDMENT.

Article II., Section 1.

The membership of this League shall be without limit, provided that at no time shall more than \$5,000 be paid as a death benefit for the death of a member of the full rate class, nor more than \$2,500 be paid as a death benefit for the death of a member of the half rate class.

Article V., Section 3, to read.

On and after February 1, 1891, there shall be two classes of members, to be known as "Full Rate Members" and "Half Rate Members." In addition to the annual dues on all members, provided for in Article XII., Sec. 4, there shall be assessed by the Executive Committee, upon all members admitted to the League prior to February 1, 1891, for the death of a Full Rate Member, a sum equal to the amount assessed on them,

when admitted; and for the death of a Half Rate Member, a sum equal to one-half of the amount assessed upon a full rate member admitted prior to this Section taking effect; and upon all members admitted subsequent to February 1, 1891, an amount equal to the sums named in the following table :

FOR THE DEATH OF A FULL RATE MEMBER.

	Full Rate Member.	Half Rate Member.
Between the ages of 21 and 29 years inclusive.....	\$2.00	\$1.00
Between the ages 30 and 34 years, inclusive.....	2.50	1.25
Between the ages of 35 and 39 years, inclusive.....	3.00	1.50
Between the ages of 40 and 44 years, inclusive.....	4.00	2.00

FOR THE DEATH OF A HALF RATE MEMBER.

	Full Rate Member.	Half Rate Member.
Between the ages of 21 and 29 years, inclusive.....	\$1.00	\$.50
Between the ages of 30 and 34 years, inclusive.....	1.25	.63
Between the ages of 35 and 39 years, inclusive.....	1.50	.75
Between the ages of 40 and 44 years, inclusive.....	2.00	1.00

Article V., Section 4.

On and after August 1, 1891, a member paying full rates who has no unpaid assessment charged against him, may give written notice to the League, at any time, to change and pay only half rates, from and after a date named by him in said notice, provided that such member shall pay full rates on all assessments ordered before the date of such change, and he shall surrender to the League his former benefit certificate, which with a certificate of the change and the members notice thereof, shall be filed with the Secretary, who shall issue a half rate certificate to such member, provided the consent of the Executive Committee shall have been obtained, which consent may be withheld at the option of such Committee.

SECTION 5.—A half rate member under forty-five years of age, may change to a full rate member by making written application to and receiving the consent of the Executive Committee, after being examined and recommended in the manner prescribed for new members, and he shall pay as an assessment thereafter, in addition to his previous assessment, one-half of a full rate assessment for his age at the time he changes. Said application must be accompanied by the additional amount required for the new assessment. The member so changing, shall surrender his former benefit certificate to the Secretary, who shall lay it, together with the examiner's certificate and the application (certifying thereon the date when the old assessment ends and the new one begins) before the Executive Committee, who, in their discretion, may direct the Secretary to issue a new benefit certificate to said member.

Article VI., Payments.

SECTION 1.—The amount arising from the payment, by each admitted member, of his first assessment, together with the assessment ordered by the Executive Committee upon each other member, shall be placed in a Trust Company as a special deposit.

Upon satisfactory proof of the death of any member who is in good standing, and not under suspension for any cause at the time of his decease, there shall be paid the following amounts :

For a Full Rate Member.....	\$5,000
For a Half Rate Member.....	2,500

Provided, however, that should a death occur when one full assessment on each member would not amount to Five Thousand Dollars (\$5,000), plus 3½ per cent. for expenses, then the sum paid shall be to the beneficiary of a full rate member, the full amount of such assessment for a full rate member, less 3½ per cent. for expenses; and to the beneficiary of a half rate member, less 3½ per cent. for expenses; and such amounts when paid, shall be in full settlement of all claims growing out of the death of such member.

The payment shall be to the person or persons whose names shall, at the time of the death of such member, be found recorded as his last designated beneficiary or beneficiaries, who shall in all cases be some person or persons having an insurable interest in the life of such member; or in case such beneficiary or beneficiaries

THE BOWDEN Seamless Plain Ring,

IS MADE ONLY BY

J. B. BOWDEN & CO.,

Makers of FINGER RINGS of
every Description,

COR. BROADWAY & JOHN STREET,

NEW YORK.

ESTABLISHED 1834.

G. & S. OWEN & CO.

MAKERS OF

FINE JEWELRY,

Lace Pins, Ear Rings, Scarf Pins, Sleeve Buttons, Sash Pins, Collar Buttons, Bracelets, Studs.

All Goods sold by us are exclusively of our own manufacture and are warranted 14 K. Fine, and stamped as such when possible.

No. 3 MAIDEN LANE, NEW YORK.

shall have died, then to such other person or persons as in the judgment of the Committee, may be most dependent on and entitled to receive from the said member said amount, which shall be distributed as a gratuity on behalf of such member, among such persons as the Committee may deem just and equitable. Immediately after having ordered payment of a death loss, except when such loss is paid from the Contingent Fund, the Executive Committee shall order another assessment upon each member, to be used in like manner. Whenever the amount in this special deposit exceeds the sum of Five Thousand Dollars, the excess shall be transferred to the Contingent Fund.

A. Herman asked if a full-rate member could also be a half-rate member. J. W. Beacham, as chairman of the committee, replied in the negative. Jacob Strauss moved that each section of the proposed amendment be considered by itself. This was seconded, but before being voted upon David Untermyer said it would be impossible; it should be submitted as a whole. It was so ruled. J. B. Bowden at this point again took the chair.

Mr. Bardel here rose and declared that it was impossible to go into a deliberation of the proposition part by part, and that as a whole he was opposed to it. The Jewelers' League, he stated, was in its thirteenth year and stronger than ever before. The surplus was over \$113,000 and the increase of members during 1890 was twenty-nine. He said that it was best to leave well enough alone and moved to lay the entire matter upon the table for all time. The applause from the members opposed to the amendment at the close of this argument was deafening. J. W. Beacham, as chairman of the Committee on Half-Rate Membership, was called to the platform, and read the following elaborate and carefully prepared communication from the committee.

Mr. President and Gentlemen of the Jewelers' League:

Before this question is voted upon, permit me as a member of the special committee of five, appointed to consider the subject of a half-rate membership under the following resolution:

Resolved, That a committee consisting of five persons be appointed by the chair, three from the membership at large and two from the Executive Committee, the Secretary to be *ex-officio* member of the committee, whose duty shall be to consider, and, if possible, devise a plan whereby a half-rate membership may be organized and incorporated into the Jewelers' League.

Second, Resolved that the provisions of this plan must be of such a character as to in no wise jeopardize the interests of the present members.

Third, That its provisions must insure exact equities to all persons concerned.

Fourth, That the plan must be of such a character as to insure additional financial strength of the League, adopted at your last annual meeting January 21, 1890, to say: The committee has given the subject a great deal of careful consideration, and believe, in the amendment offered they have devised a plan which in no wise jeopardizes the interests of the present members. That its provisions insure equities to all concerned as nearly as it is wise to do so, and will undoubtedly result in material additional financial strength to the League.

The Committee is of the opinion that the admission of a class of half rate members will in no sense jeopardize the interests of the present members more than will the admission of new full rate members; because what is the interest of a full rate member is also the interest of a half rate member.

The Committee might have devised a plan of exact equity from a pecuniary standpoint, by making the death losses assessments and annual dues just one half those of a full rate member. But it found there was no way in which the vote of a half rate member

could be counted as a half rate vote—as it was informed that by law a vote of a half rate member counts just the same as that of a full rate member. Therefore, to counteract this advantage (which is the only one the half rate members have in the scheme), our plan provides: that while the death losses and assessments of half rate members shall be just one-half those of full rate members of the same age, the annual dues of *all* members, whether full or half rate shall be \$4.00 per year: thus insuring a liberal sum each year for the contingent or guarantee fund.

The Committee believe the scheme will materially strengthen the League financially, numerically and popularly, because there is a large number of young men who are not able to carry a full rate membership, but who will be glad to avail themselves of a half rate class. These are a very desirable class of members, because they are young, and are, consequently, extra good risks; then, too, bear in mind they will be contributing to our contingent or guarantee fund as much every year as full rate members.

When I was appointed on the committee to consider this subject, I was opposed to the plan, believing it would be detrimental to the old members: but after a careful study of it in all its bearings, seeking such light and advise as I could find, including the opinion of an eminent actuary of a large life insurance company, I am convinced that the amendment may be adopted, not only with perfect safety to the old members, but to their great advantage. Other members of the committee entered into the discussion of the subject, who at first were opposed to it. But a thorough study of it has brought us all (as I think it will anyone who carefully looks into the matter) around to regard the movement with favor; and the committee therefore unanimously recommend the adoption of the amendment.

Here I ought to say that the committee *did* unanimously sign the report recommending the adoption of the amendments. But I learned a few moments ago, that one member of the committee has since changed his mind.

We all recognize the fact, that in order to secure our insurance we must keep the membership up to at least 2,600 full members or its equivalent.

The League during the past year, through the efforts of a paid solicitor, has just about held its own. I believe a large number of young (and therefore desirable) men will avail themselves of the half rate class, and thus largely increase our number. Another advantage is the divided risk. For instance—two half-rate members of the age of say twenty-seven, are a better risk for the League than would be one full rate member of the same age; for the reason that the chances of death are as *one to two*; and the contingent fund will be better off by \$4 from the two half rate members. Most merchants would rather sell two bills of \$2,500 each to two good customers, than one bill of \$5,000 to one customer equally good, and so half rate members are really more desirable than full rate members.

Again, increased numbers are desirable for the reason that every member becomes a friend and uses his influence in favor of the League. Increased membership does not necessarily mean an increased number of assessments; for so long as the deaths do not exceed one per cent. of our membership (and they have never yet reached that point) there need not be more than twenty-six full assessments each year, even if the membership should reach 10,000 or 100,000, as you will readily see from the following examples:

EXAMPLE 1.

A Membership of 10,000.			
10,000 full members at \$52 each	yield		\$520,000
Annual dues 5,000 at \$4		40,000	\$560,000
100 death losses \$5,000 each		500,000	
Expenses 3½ per cent		17,500	517,500
Yields to contingent fund for the year			\$42,500

EXAMPLE 2.

9,000 full members at \$52		468,000	
1,000 half " " 26		26,000	
10,000 annual dues " 4		40,000	\$534,000
90 deaths full members at \$5,000		450,000	
10 " half " " 2,500		25,000	
3½ per cent. for expenses		16,625	491,625
Surplus to contingent fund			\$42,375

EXAMPLE 3.

7,000 full at \$52		\$364,000	
3,000 half " \$26		78,000	
10,000 annual dues at \$4		40,000	\$482,000
70 deaths full at \$5,000		\$350,000	
30 " half " \$2,500		75,000	
3½ per cent. expenses		14,875	439,875
Surplus to contingent			\$42,125

EXAMPLE 4.

5,000 full at \$52		\$260,000	
5,000 half " \$26		130,000	
10,000 annual dues at \$4		40,000	\$430,000
50 deaths full at \$5,000		250,000	
50 " half at \$2,500		125,000	
3½ per cent. Expenses		13,125	388,125
Surplus to contingent fund			\$41,875

EXAMPLE 5.

3,000 full at 52		156,000	
7,000 half at 26		182,000	
10,000 annual dues at \$4		40,000	378,000
30 deaths full at \$5,000		150,000	
70 " half at \$2,500		175,000	
3½ per cent. Expenses		11,375	336,375
Surplus to contingent fund			\$41,625

EXAMPLE 6.

1,000 full at 52		52,000	
9,000 half at 26		234,000	
10,000 annual dues at \$4		40,000	\$326,000
10 deaths at \$5,000		50,000	
90 " at \$2,500		225,000	
3½ per cent. expenses		9,625	284,625
Surplus to contingent fund			\$41,375

EXAMPLE 7.

10,000 half at 26		260,000	
Annual dues at \$4		40,000	300,000
100 deaths at \$4		250,000	
3½ per cent. expenses		8,750	258,750
Surplus to contingent fund			\$41,250

There is one more example to which your attention is particularly requested, as it is based upon the experience of the League during the year 1890, and is used to show what the effect upon the condition of the League would be if a class of half-rate members is admitted. For the convenience of figuring I use the lowest grade assessment, namely \$2 for the full-rate and \$1 for the half-rate: and for the sake of brevity leave out entirely the question of expenses, which would be proportionately the same. The report just printed shows a membership of 2,750, and 25 death losses—which is just exactly one death to every 110 members.

EXAMPLE.

2,750 full members 25 assessments of \$2 each	yield	\$137,500
25 death losses \$5,000 each require		125,000
Surplus,		\$12,500

Now then, for illustration, we will say we had during the same time, a class of 110 half-rate members: and I make the numbers 110, because the experience of the year shows one death from this number. The result then is as follows:

2,750 full members contribute for 25 full-rate deaths.....	\$137,500
2,750 full members contribute for one-half-rate death.....	2,750
<hr/>	
To pay 25 full-rate deaths at \$5,000 each, requires.....	125,000
Surplus as regards full rate members per man.....	
Annual dues per man.....	\$5.54 15,250
Total surplus as regards full members per man.....	4.00 11,000
<hr/>	
110 half members contribute for 25 full-rate deaths.....	2,750
110 half members contribute for one half-rate death.....	55
<hr/>	
To pay one half-rate death requires	2,500

WALTHAM

NEW MODEL

16 SIZE HUNTING PENDANT SETTING

ROYAL MOVEMENTS



NOW ON THE MARKET.

Surplus as regards half-rate mem- bers per man.....	\$2.73	\$ 305
Annual dues per man.....	4.00	440
Total surplus as regards half mem- bers per man.....	\$6.73	\$ 745

Another point in this example to which I invite your careful attention is, that the half-rate class is not only self-sustaining, but it actually pays in to the contingent fund *more*, in proportion to its interest in that fund, than does the full-rate class.

The contingent liability of the League for death loss, is just exactly the same to one full-rate member (namely \$5,000) as it is to two half-rate members (\$2,500 each); and while the two half-rate members pay in assessments exactly the same amount as one full-rate member of the same age does, the two half-rate members pay in annual dues into the contingent reserve fund just *double* what the full-rate member does.

It is therefore very apparent that the *half-rate members are a source of greater financial strength to the League, than are the full-rate members.*

If there be any one here who fears the votes of these half-rate members, to them I would say: 1st. There is no more to be feared from the vote of a half-rate member than there is from any new member admitted since the plan of graded assessment was adopted. 2d. All who join the League soon learn that they are getting their insurance at exact cost and will always vote to preserve the League and make it a success. 3d. It requires a two-thirds vote of those present to amend the constitution, after due notice: and as we now have 2,700 full members, it will be many long years before the half-rate members will have a two-thirds majority.

In conclusion, I beg to say that the Committee, after thorough and careful examination, unanimously recommend the amendment to your favorable consideration, believing that it will result in great good to the League, and hope you will indorse their labors by your votes.

Now please observe that in this combination the full-rate members contribute for the benefit of half-rate members \$2,750; and that the half-rate members contribute for the benefit of full-rate members just exactly the same amount, namely \$2,750, thus balancing the obligation to a cent. Observe also that out of the assessments the half-rate members contribute to the Surplus Fund \$2.73 per man, just one-half what the full-rate members do. And to this point they are on a perfect equality, but when you add the annual dues of each, you find that the

Half-rate members contribute to the Surplus Fund.....	\$6.73
Full.....	9.54

A gain or advantage to the Full Rate Members of \$2 on each half-rate member admitted.

The report as above printed contains several additions which the speaker interpolated during his reading. The inquiry, the investigation, the care in preparation and the amount of intelligence and hard work on the part of the framers disclosed by this report, won the respect of even the hottest opponent. Since a motion to lay an amendment upon the table is not debatable, a vote was called for. As the ayes and nays were of about equal vociferation a standing count was ordered, and the result was a defeat for half-rate membership by 110 to 21.

The secretary next read the following communication.

MR. ROTHSCHILD'S PLAN

NEW YORK, January 20, 1891.

Mr. Wm. L. Sexton, Secretary and Treasurer, the Jewelers' League of New York:

DEAR SIR: The amendments proposed in your last circular only aim at a part of the evil of non-insuring insurance. To put the Jewelers' League of New York upon the basis on which substantial insurance companies stand is no easy task, and a system of patching, though it produces temporary good effects, will, in the course of a few years be dissipated, and once more the League will be forced to face the issue of promising more than can be fulfilled.

I respectfully offer the following suggestions, briefly outlining the same, the details of my plan to be perfected by the executive committee, should they deem it wise and available:

First—To organize a separate or sister insurance plan to work under the same management as the present one, but to be financially separated.

Second—Insurance No. 2 to be graded according to age as per best actuary advice on the subject.

Third—Policies to be issued to all desirable applicants in sums of from \$500 to \$5,000.

Fourth—Any member of the present insurance can change to insurance No. 2 under the same conditions and rates as new applicants would have to comply with.

Fifth—Payment of a graded yearly sum, as fixed annual dues.

Sixth—Provision for separate reserve fund.

Seventh—Provision (if legal) for the gradual transfer of pro rata shares of the reserve fund from the present insurance to insurance No. 2, provided a large number of our members change to the new insurance.

To sum up, the new plan should be made on a solid, unimpeachable insurance basis. This will attract new members, and also gradually absorb the members of the present insurance. So, in the course of a number of years, the new league will be not only an insurance for those who die soon, but a certainty for the last members—for the men who will pay for the many years longer and who now justly doubt if there will be anything left for their heirs after they answer Gabriel's call. The above is respectfully submitted.

M. L. ROTHSCHILD.

On motion the communication was laid on the table.

As miscellaneous business, the secretary read the proposed amendment in relation to date of annual meetings as follows:

By-Laws. Article III., Section 1.

"The Annual Meeting of the League shall be held upon the first Tuesday in February of each year."

The present By-Laws provide for the meeting to be held upon the third Tuesday of January.

The reason for this change was, the secretary said, to provide a date for meeting that would be more convenient for visiting jobbers. A. Schwab said that more jewelers visit New York in January than in the first week of February. Henry Untermyer moved to lay the matter on the table. It was done.

Geo. R. Howe at this point rose, and, referring to the communication read by Mr. Beacham, said that although he was opposed to the amendment, the report offered was the most perfectly prepared plan ever submitted to the league, and moved that a vote of thanks be tendered to the committee that had worked so hard in the matter. This motion was enthusiastically received and was unanimously carried.

President Hayes here said that, without having given much thought to the matter, it was his idea that a second class of members could be legally admitted as an independent separate body. He said he would like to see a trial made and proposed that a committee be appointed to devise a plan. This address caused quite a hubbub, one member asking what connection such a body would bear to the present league. Another spoke of it as a rival League. It was voted down.

S. B. Kent asked if Mr. Jones, the company's agent, had anything to say. The latter thereupon went upon the platform, and delivered a neat and witty speech. The president appointed W. H. Todd, A. G. Schwab and Frank Benedict as the Finance Committee, and then the meeting adjourned.

AIKIN, LAMBERT & Co.,
23 Maiden Lane,
NEW YORK,

Manufacturers and Exporters of

Fine Gold Pens, Pencils,
TOOTH PICKS, HOLDERS,
And Novelties in Silver, Pearl, &c.



THE BEST FOUNTAIN PENS.

New Assortments in SHOW CASES and FANCY TRAYS for JEWELERS.
Price Lists and Catalogues for intending Purchasers.



Also American and Swiss Watches.

DIAMONDS, Loose and Mounted,

Gold and Silver Thimbles,
CHAINS and JEWELRY in New and Staple Patterns

S. COTTLE & CO.,

MAKERS OF

**FINE JEWELRY AND SILVER
NOVELTIES,**

No. 860 Broadway, NEW YORK.

WOOD & HUGHES,

Sterling Silverware Manufacturers.

New York Agents for the Derby Silver Co.'s FINE QUADRUPLED PLATED WARE.

No. 16 JOHN STREET, NEW YORK.

206 Kearney St., San Francisco, Cal.

HASKELL & MUEGGE, Agents.

J. R. WOOD & SONS,



Manufacturers

of



PLAIN SOLID GOLD RINGS,

Also Engraved, Chased, and Silver Rings.
No goods stamped different from quality.

14 JOHN STREET, NEW YORK.

PRICE LIST.

18 K	-	-	-	.87	14 K Flat Engraved,	.83
14	"	-	-	.71	10 K "	.67
10	"	-	-	.55	14 K Half Round Chased,	.77

Old Gold and Silver received and estimated on; if amount allowed does not give satisfaction, notify at once and will return at our expense, in same condition as received.

A. BANTLE,

GOLD and SILVER

Electro-plating.

Fine Etruscan

COLORING.

Oxidising

Silver, and

Bronzing on Metals

FOR THE TRADE.

130 Fulton St. & 89 Nassau St., N.Y.

MULLER BRONZE CO.

Underhill & St. Marks Aves., BROOKLYN, N. Y.

MANUFACTURERS OF FINE

BRONZE ORNAMENTS FOR THE CLOCK AND JEWELRY TRADE.



HISTORY. No. 121.

ALL
FIRST CLASS JOBBERS
HANDLE THEM.

NEW CONCERN. NEW GOODS.



ARTIST. No. 112.

THE time-keeping qualities of Illinois Springfield Watches are unsurpassed; they are handsome in design and the very best finished movements on the market.

Our 18 and 16-size movements in open face have the best pendant setting device ever used.

A comparison of our line of 16-size movements with those of other manufacture, is all we ask; if they are not more accurately timed and adjusted, better finished, and handsomer in appearance, don't buy, them.

We guarantee every movement of our manufacture and have no hesitancy in recommending them.

Our movements are sold direct to the retail trade and through our special jobbers.

Send for price-lists, illustrated catalogue and electrotypes.

ILLINOIS WATCH COMPANY,
SPRINGFIELD.

NEW YORK,
11 John Street.

SAN FRANCISCO,
220 Sutter Street.

CHICAGO,
104 State Street.

The Jewelers' Security Alliance.

THE regular monthly meeting of the Executive Committee was held at the Alliance Office on January 9.

There were present Vice-Pres. A. K. Sloan and David Untermeyer, Chas. G. Lewis, Treas.; Messrs. White, Karsch and Geo. H. Hodenpyl, Sec'y. The following applicants were admitted to membership:

Wm. S. Shirk, 78 E. Eighth street, Anderson, Ind.; H. M. Richards & Co., 7 Green street, Boston, Mass.; Henry E. Oppenheimer & Co., 47 Maiden Lane, City; Chas. M. McFarland & Co., 415 Main street, Worcester, Mass.; Chas. L. Furry, Alden, Iowa.

The Jewelers' League.

AT the regular meeting of the Executive Committee of the Jewelers' League, held on January 2d, there were present Vice-Presidents Lewis, Snow and Greason and Messrs. Howe, Untermeyer, Jannot, Jenks, Houghton and Sexton. Six requests for change of beneficiary were granted, one application was referred for investigation and the following applicants were accepted to membership: Chas. R. Bates, Attleboro, Mass. proposed by E. C. Glines, Arthur H. Bogani, New York, N. Y., proposed by W. L. Ballou and W. C. Parks, Henry A. Hovet, New York, N. Y., proposed by W. H. Shipman and E. Scheffer; David J. Larkins, New York, N. Y., proposed by Geo. H. Houghton; C. P. Seabury, Jr., New Bedford, Mass., proposed by J. W. Beacham and G. C. White; W. T. Sherman, New York, N. Y. proposed by L. Stevens, Jr., and J. H. Ingens.

At the special meeting of the Committee held January 15th, the following applicants were accepted to membership: Wm. H. Bedford, London, Eng., recommended by C. G. Lewis and J. C. Mount; J. M. Bigwood, Terra Haute, Ind., recommended by J. Bernhardt and S. Fink; W. W. Bloomer, Pawtuxet, R. I., recommended by E. De F. Wilkinson and H. F. Payton; W. Hunter Brown, Jersey City Heights, N. J., recommended by C. B. Langhaar and J. F. Angell; H. W. Butts, New York, N. Y., recommended by F. Bigley and C. W. Bridgman; A. A. Hart, St. Louis, Mo., recommended by C. F. Langhaar and W. Hunter Brown; H. Heller, Providence, R. I., recommended by B. Lederer and W. Lansing; A. H. Oakley, Newark, N. J., recommended by J. A. Smith and W. A. Bryant; Chas. W. Rinn, Allentown, Pa., recommended by E. Keller and L. Fisher; H. E. Slater, Elizabeth, N. J., recommended by O. N. Wright and C. H. Hodenpyl; J. J. Sommer, Brooklyn, N. Y., recommended by J. J. Fergerty and J. W. Senior.

Lancaster.

[From Our Special Correspondent.]

JANUARY 31.

The prospects of the resumption of work at the Keystone Watch Factory are considered very poor. D. Ramsay Patterson, Philadelphia, the assignee of the company,

is endeavoring to sell the property, and several parties have inspected it. None, however were interested in the watch or jewelry trade.

The wife and child of James M. Jenks, traveling salesman for Ernest Zahm, manufacturing jeweler of this city, have been very seriously ill for the past six weeks, but are now believed to be out of danger. Mr. Jenks expects to resume his route in about two weeks, and make his full run to the Pacific coast.

Col. J. M. Rutherford, the well known auctioneer, during the month of December, sold jewelry to the amount of \$31,000 in Pittsburgh.

Among the traveling men noticed in town during the past few days, were the following: Fred. Baker, with Hayden W. Wheeler & Co.; Fred. Kauffman, of New York; Mr. Cogglin, representing the Towle Manufacturing Co.; A. D. Miller, with the Pairpoint Manufacturing Co.; Mr. Hull, of the Silver Plate Cutlery Co., Birmingham, Conn.; and Wm. Link, of Newark, N. J.

The demand for the old-fashioned corner clock is quite large hereabouts. Walter C. Herr has just had one fitted up in a particularly handsome manner. The case is of mahogany finish, and the dial is black, with good lettering and gold hands. The ornaments are of brass.

F. J. Schmitt, Geo. A. Kruttschmitt, and Charles A. Vaughn, of Newark, N. J., manufacturers of jewelers' tools were in the city a few days ago inspecting several industrial sites. If satisfactory arrangements can be made they will probably move their industry to this city.

Denver.

[From Our Special Correspondent.]

JANUARY 28.

Jervis Jolson, of the firm of Joslin & Park, is in New York.

Mr. S. R. Hall has been engaged as watchmaker with C. E. Ford, Optician and Jeweler.

F. L. Smith, of the C. H. Green Jewelry Co., is in New York.

Albert P. Bill, jeweler for several years at 1536 Plate street, died on February 16th. His stock will be closed out and the business discontinued.

H. L. Chapin has moved from No. 917 Sixteenth street to No. 1516 Court place, and will occupy a store of his own.

Knight & Son, of the Knight-McClure Music Co., have purchased a large stock of jewelry and will open up on February 2d in the building occupied by the latter firm, at Nos. 1637-43 Lawrence street. George Chapriot, an experienced watchmaker and jeweler, will have charge of that department.

From All Over.

The Ottawa *Journal* announces a large jewelry robbery in Centre Town, Ottawa, but gives no names. Detective Montgomery is on the case.

Mr. Fred S. Ladd, of Thomsonville, Conn., formerly with R. F. King & Co., has started in business on his own account.

Frank A. Smyth, secretary and confidential clerk of the J. R. White Jewelry Company, Rochester, N. Y., was united in marriage, at the Church of the Holy Redeemer, on Wednesday afternoon, January 28th, to Miss Carrie Griebel.

The annual statement of the J. R. White Jewelry Company shows: Capital stock, \$250,000; all paid in. Debts, \$35,969.34.

The store at Nos. 166 and 168 Genesee street, Utica, N. Y., now occupied by E. L. Akehurst, will soon be occupied by R. C. Burton, dealer in sheet music and musical instruments. Kirtland & Gillmore, jewelers, will also occupy a portion of the store.

George Russell, an engraver of jewelry, was arrested at Batava, N. Y., on Jan. 27th, on a charge of stealing a watch and chain belonging to James Metcalf.

Mr. E. M. Banton, formerly of the jewelry firm of Banton & Robertson, Bangor, Me., has accepted a position with W. H. Blacar, the jeweler on Kenduskeag Bridge.

Mr. R. J. Cushing, who has recently opened a new jewelry store in Bangor, Me., is one of the finest jewelers in Maine. Mr. Cushing's store is fitted up with all the modern conveniences, and experts who have seen the interior of the room say that there is not a store in New England fitted up in better style. The cabinet is of solid mahogany, highly polished and finished. The work bench is also made of mahogany and is from a manufactory in Chicago. Since Mr. Cushing moved into his new quarters, he has been visited by fire damaging his stock about \$100.

CYRUS CONDIT, who for six years past has been located at 829 East 12th street, Kansas City, Mo., has moved to 2344 Drripp street, same city.

Mr. S. B. Wheeler, of Minneapolis, has opened a jewelry store in the drug store at Hancock, Minn.

A. Barnard, of Duluth, has taken his stock and will open a store in West Duluth.

A. Frank, one of Winona's jewelers, has changed his place of business, having moved his stock of goods directly across the street from his recent location.

Mr. Ed. Mechler, the popular jeweler of Barnesville, Minn., expects soon to remove to West Bend, Wis.

William Simmons, of Muncie, Ind., who figured quite conspicuously in several local robberies in this neighborhood last November, and who stole three diamond rings from Henry Falsom, the Rock Island jeweler, plead guilty in the Rock Island District Court, the 14th inst. to grand larceny. He was sentenced to two years in the penitentiary at Joliet.

W. H. Gorman has removed from No. 16 King street, Taunton, to No. 95 Bucklin street, Providence, R. I.

Treasures valued at 200,000 lire have been stolen from the sacristy of the cathedral at Placenza.

The assigned stock of C. W. Mc Kee, of this place has been invoiced and appraised and Assignee C. H. Worded has opened the sale and placed Mr. McKee and his son Edward in charge. The stock will be sold at private sale.

Frank Voirol, the well-known watch-maker, of Ft. Wayne Ind., is slowly recovering from the injuries he received by falling down a stairway. Although three of his ribs are fractured he is in a fair way to complete recovery. Mr. Voirol is still hearty and was much more active before his accident than many others who had not seen so many years.

W. F. Doll, of Winnipeg, was noticed in Montreal the other day. He is on his way to the American markets.

F. Addison, traveling salesman with Geo. Chillas, of Toronto, is about to make a change and start with Mr. J. H. Eaves. He is the old eastern representative of Fair & Co., Toronto.

M. C. Ellis of Toronto has just returned from New York City, having become the exclusive Canadian agent for R. F. Simmons' & Co.'s plated chains.

Sidney H. Lee, of F. H. Lee & Son, of Toronto, was in Montreal recently on the way home from a purchasing trip to New York.

The jewelry store of Jacques & Co., Winnipeg, Man., was robbed on January 20 of goods to the amount of \$4,000. It took about a week to find a clue to the thieves. The combination of the safe had been picked, and suspicion fell on a clerk who has been committed for trial.

John J. Aikenhead, jeweler, 351 Spaditra avenue, Toronto, has assigned to E. R. C. Clarkson, of that city. The liabilities are estimated at about \$3,000, and assets \$2,000.

Mr. Spangenberg, jeweler, of Kingston, Ont., is engraving on the links of the civic chain of the mayor the names of all Kingstons mayors since 1840.

The Last Week's Arrival.

A. Anderson, Boston, Grand Union; M. Burchard, Chicago, Murray Hill; J. P. Staats, Chicago, St. Denis; R. Joslin, Denver, Belvedere; W. Morris, Philadelphia, Earles Hotel; S. A. Huser, Albany, St. Stephens; G. A. Creighton, Lynn, Astor House; E. Havens, Terre Haute, Murray Hill; C. Fricker, Americus, Ga., St. Stephens; C. S. Gill, Lancaster, Westminster; J. Linz, Sherman, Tex., Astor House; W. Hill, Chicago, Barrett House; G. H. England, Holyoke, Astor House; E. R. Bennett, Amherst, Astor House; L. Manson, Syracuse, Astor House; J. H. Smith, Baltimore, Bartholdi; W. S. Wilkinson, Chicago, Continental; M. Zineman, Philadelphia, Continental; F. A. Hardy, Chicago, Murray Hill; J. N. C. Weinman, Philadelphia, Sturtevant; R. Schmidt, Rochester, Union Square; C. W. Freeman, Scranton, Grand Central.

JEANNOT & SHIEBLER



Fine Gold Watch Cases.

**No. 20 MAIDEN LANE,
New York.**

Constantly on hand, 14k. and 18k. Cases to fit any Movements in the Market.

GEO. W. SHIEBLER,

SILVERSMITH.



Artistic Novelties.

HOLLOW AND FLAT WARE.

Sterling Silver.

No. 8. Liberty Place,

NEW YORK.

*** JAS. W. MILLER, SUCCESSOR TO MILLER BROS. & Co. MANUFACTURER OF FINE GOLD JEWELRY 37 UNION SQUARE, NEW YORK. INITIAL GOODS A SPECIALTY.

The Patent O. F. Cases have these Advantages over the Regular Case: It is Dust Proof and Decidedly Cheaper.

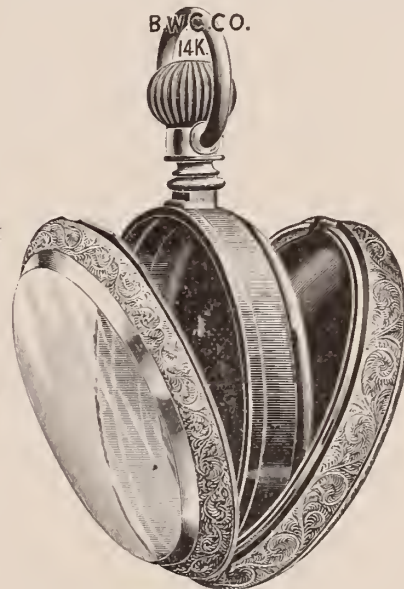

EXAMINE THIS

NOVELTY IN 14-K.

THE BROOKLYN WATCH CASE CO.

192 Broadway, New York,

HAVE IN STOCK AND FOR SALE BY ALL JOBBER

❖ 14-K. Brooklyn Eagle Wheat and Granger ❖

GOLD CASES IN 18, 16, 6, 14 AND 0 SIZES ADAPTED TO ALL MOVEMENTS OF THE ELGIN MODEL.

Board of Trade Meeting.

**E. J. Scofield Re-Elected President—
Board of Directors Appointed—Members Present.**

THE Sixth Annual Meeting of the New York Jewelers' Board of Trade was held at 2:30 o'clock of January 29, at the Board's rooms, 41 Maiden Lane. When order was obtained Secretary Condit called the roll, members of the following firms responding, Brooklyn Watch Case Co., Downing, Keller & Co., Henry Dreyfus & Co., Elgin National Watch Co., Jos. Fahys & Co., Max Freund & Co., Henry Ginnel & Co., Ingomar Goldsmith & Co., Gunzburger Bros., Leon Hirsch, Hodenpyl & Sons, Keller, Ettinger & Fink, Keller & Untermeyer, Sol Lindenborn, A. Lorsch & Co., Low, Weinberg & Hyman, S. F. Myers & Co., Oppenheimer Bros., & Veith, H. Z & H. Oppenheimer, Adolphe Schwob, Spencer Optical Mfg. Co., Stern Bros. & Co., Sussfield, Lorsch & Co., Weis & Oppenheimer, N. H. White & Co.

President E. J. Scofield then addressed the meeting as follows:

GENTLEMEN; We are called together once more on this our Sixth Annual Meeting to listen to the reports of your officers and to elect directors for the ensuing year.

I do not intend to take up much of your time with any remarks, as the reports which will be read will embody most all that I could say. I, however, cannot lose this opportunity to congratulate you one and all upon the success which has attended the Board during the past year. We have added largely to our membership and have to-day a Board room which is a credit to us.

We now enter upon our seventh year and the New York J. B. of T. is no longer an experiment. It is an assured fact; it has only been by hard and faithful work on the part of your directors aided largely by its members, that the Board has attained the position which it now occupies in the trade and which it intends to maintain.

I want to take this opportunity to publicly express my gratitude to my fellow directors for the aid and support which they have given to this Board during the past year. Often at a sacrifice of their own personal business they have attended the meetings of the Board, and by their counsel and advice have largely aided in making it the success which it now is.

I would also take this occasion to remind the members of the Board that they also have a duty to perform and can do much toward making the Board a much greater success.

To carry out our work effectually we need money but we do not wish in any way to increase our revenue by an increase of dues.

Last year we added about twenty-five names to the list of membership. This year we should at least add 100. If each and every member would feel it incumbent upon himself to bring in at least one member it would not only strengthen our Board but would give us the means by which more effectual service could be rendered, and I trust that each and every one of you will do what you can to strengthen our organization in that direction.

There is one other matter to which I would call your attention, and that is the giving of information pertaining to the trade. I have received several complaints from members that they are unable to get satisfactory information. This does not apply to the reports which are now in this office, but to special inquiries which we are obliged to make from our fellow-members.

Now, our association is in one sense of the word a mutual benefit organization, and if we seek information we should certainly be willing to give it. I sincerely trust that one and all will in the future give such information when called upon as will aid us in making satisfactory reports of individuals or firms when called upon.

We will now listen to the reading of the minutes of the last meeting.

The reading of the minutes of the last meeting was next in order. It was moved to dispense with this business, and Secretary Condit then read his annual report. The report showed a prosperous condition of the board.

The election of the Board of Directors for the ensuing year was next taken up President Scofield appointing A. Schwob, Albert Lorsch and M. Weis, as a nominating committee. The following were nominated: E. J. Scofield, Samuel Aufhauser, J. C. Downing, Geo. E. Fahys, O. C. Fessenden, Gurdon W. Hull, David Keller, M. J. Lissauer, S. F. Myers, August Oppenheimer, Frank Simmons, Anton Hodenpyl, Leopold Stern, Henry Dreyfus, J. E. Spencer, O. Brahe, F. E. Parsons, Frank H. Richardson, M. D. Rothschild. A. Lorsch was nominated but declined; the following were elected: E. J. Scofield, David Keller, August Oppenheimer, Sam'l Aufhauser, J. E. Spencer, J. C. Downing, G. E. Fahys, M. J. Lissauer, Henry Dreyfus, Leopold Stern, S. F. Myers, A. Hodenpyl. Frank R. Simmons and C. A. Brahe, received the same number of votes. Another ballot being taken, Mr. Simmons was elected.

For President, S. F. Myers, with words of commendation, nominated E. J. Scofield, who was elected unanimously, amid applause. Leopold Stern was nominated for first vice-president and unaniously re-elected. S. F. Myers received the nomination for second vice-president in place of Gurdon W. Hull and was also unanimously elected, as was David Keller re-elected to the treasurership.

Leopold Stern then moved that a vote of thanks be tendered to Sec'y H. M. Condit for the efficient and faithful manner in which he had discharged his duties, during the past year. The motion was carried. The secretary then rose and read the following communication from M. D. Rothschild:

To the New York Jewelers' Board of Trade, New York City.

GENTLEMEN: I hereby offer the following resolution and trust it will be adopted: M. D. ROTHSCHILD.

RESOLVED, By the New York J. B. of Trade that the action of the United States Senate in passing a bill providing for the free coinage of silver is a dangerous menace to the business interests of the country.

RESOLVED, that this association respectfully and earnestly protest against the passage of the Senate free coinage bill by the House of Representatives of the United States, and that a copy of these resolutions be forwarded to the Speaker of the House.

Leopold Stern motioned to send the above to the Finance Committee, and it was decided to do so.

Hard On the Jeweler.

A DIAMOND necklace formed of a single row of enormous solitaires suspended from a slender gold chain set with little diamonds, each stone a marvel of purity and brilliancy as well as size, adorns the show-room of a Paris jewelry store. This splendid ornament was to have formed the Christmas gift of one of the partners in the banking-house of Baring Bros. to his wife, but when misfortune befell the firm the necklace was left on the jeweler's hands. It is valued at \$200,000.



PARIS, Jan. 26, 1891.

The peculiar kind of jewelry exhibiting radishes, grapes, strawberries, cherries, raspberries, etc., made of onyx or agate colored by chemical processes, and of imitation stones, with leaves in enamel and stalks wrinkled with brilliants, is still fashionable; but its comparative cheapness, that makes it accessible even to *grisettes* or work girls, will be the cause of it being soon banished by our ladies. Yet these articles have sold well lately and it matters little, after all, that their existence should prove as ephemeral as that of nature's products of which they are such good copies. Our jewelers, whose ingenuity is constantly at work, will soon devise something to replace it.

A high-class jeweler has made quite a specialty of selling bow-knots of various sizes in colored gold looking like silk. These bow-knots are much worn, either as brooches or as shoulder ornaments of a low-necked dress, at soirées. There is generally in the centre a large stone of a color harmoniously contrasting with that of the sham-silk, and small ones forming a fringe at both ends.

Scarf-pins admit of infinite variety. Horses, donkey, dogs and monkeys, besides flowers, birds, insects, coronets, emblems, etc., meet with success in this branch of jewelry. Snails, made of circular bands of contrasted colors, take the fancy of only a few. A very curious pin's head is a gold bee-hive, with bees in colored stones, apparently flying from it, but really fixed to it by an almost invisible wire.

A singular style, in jewelry, consists of ornaments and figures made of assembled gems of well chosen colors, showing on a deeply oxidized silver trellis or net which looks like iron wire. The peculiar beauty of this fashion is above all conspicuous on bracelets. One of them, in the shape of a rather wide band, exhibits a cat ready to pounce on a mouse, the last of a small part speeding fast away. The true attitude of the feline, gathering his body so as to dart off with full spring, is perfectly rendered. The stones that are assembled to form these animals are chiefly rubies, emeralds and brilliants, all very small; some being set more saliently than others, and in a way calculated to give a bas-relief effect.

Powder boxes are still hidden in all kinds of ways. Some of these treasured articles are most prettily decorated with sprigs of daisies in low-relief chasing, elongated white pearls flatly encrusted forming the petals of the flower. They often exhibit a monogram, in repoussé, tastefully sprinkled with varicolored stones.

Among the tempting display of match-boxes to be seen at a well-known place, I noticed one worked in gold. On both sides demimonde scenes are painted, bounded with curling ornaments, whose style gives still more zest to the pictures. The underside, on which matches may be scratched, is closely paved with tiny pointed brilliants.

Norfolk.

January 31st, 1891.

John W. Hinman contemplates removing about Feb. 7th from 219 to 106 Church street.

F. Driessell has removed from 103 Church street to 117 Church street, where he has more commodious quarters.

"The Casket" is the name of the establishment of Messrs. C. F. Greenwood & Bro. This sterling house is again being crowded with new and desirable goods to meet the wants of its many customers.

Frank Ogilbie, the hustling salesman of A. Alling Reeves, of New York City, was in Norfolk last week making lots of friends, besides supplying our jewelry merchants with the latest in the jewelry trade.

Nathan Frankfurt, formerly doing business at 11 Union street, has removed to the spacious store at the intersection of Main and Church streets, our busiest thoroughfares. The appearance of his store both within and without reflects great credit upon Mr. Frankfurt. The jewelry and watch repairing departments are in the front part of the store, while the musical instruments are in the back. Mr. Frankfurt's store ranks among the finest in the city.

The proprietors of the Jewelry Palace, 122 Church street, have decided to offer for competition a handsome gold watch and chain of the finest grade, set with a large, valuable diamond, and ornamented with Etruscan gold scroll work in alto relievo. It is to be voted to the most popular young lady in the cities of Norfolk, Portsmouth, and Berkley. The contest will be conducted in a fair and impartial manner. The vote will be closed at 12 o'clock M. Feb. 28 and the ballots will be counted in the presence of the friends of the contesting parties.

Voigt & Haas' Assignment.

WASHINGTON, D. C. Jan. 28.—Edward Voigt and Charles Haas, of the firm of Voigt & Haas, jewelers, who recently made an assignment for the benefit of their creditors, filed an answer in the equity court, Jan. 28th to the petition of Henry Fera and others to set aside the assignment. They admit in their answer that the property assigned amounted to about \$13,000, but deny that the deficit is \$24,000 or that there is any deficiency at all. They deny that they had an exceptionally large holiday trade or that they realized any large sums or that they have concealed moneys or done anything to hinder, delay, or defraud their creditors. They state that they first made up their minds to make an assignment after one of their creditors, Frederick Goldsmith, on January 3, tried to induce them to make an assignment with his attorney, Tobriner, as assignee, and when they were convinced that he was determined, to worry and harass them. As to the preferred creditors, they say that the debts to such creditors are all bona-fide debts. The assignee, Duffy, took immediate possession, they say, and was given the true cost-price of each article. They deny that Duffy has any intimate relations with their families or that the stock is going to waste.

Didn't Want Plated Ware.

HARRISBURG, PA., Jan. 29.—Tuesday night the clothing department of the Steelton Store Company, located on the second story of the building corner of Front and Locusts streets, was robbed by persons who were evidently acquainted with the premises. Twenty-three watches, four of them gold, a lot of gold watch chains, rings and breast pins, a box of kid gloves and several neck ties were taken. The thieves were very particular in their selectitns, leaving behind a number of plated watch chains, rings, etc., low priced goods. The clerk having the keys on entering the building found the front door leading to the stairway open. The doors on the second floor were all locked as usual. It is supposed the thief or thieves were secreted in the building before closing last night, and one door, having a dead latch, was used as an exit, the door locking as he went out. The front doors open inward and all that was

necessary was to draw down the bolts and press the doors to get out. There is no clue to the robbers, but efforts are being made to capture them. The loss is between \$200 and \$300.

A Fruitless Effort.

GLADE SPRINGS (Va.), Jan. 26.—The jewelry establishment of Thomas Jefferson was broken into on last Friday night and ransacked by some one—a tramp who loitered about the place during the afternoon is suspected. Nothing was taken, Mr. Jefferson having thoughtfully taken to his home all the valuables on hand. The shop was entered by breaking an iron pin and tearing off the shutter.

SPRINGFIELD, Mass., Jan. 26, 1891.

I have taken THE CIRCULAR for years and value it highly. H. E. BRANT.

ALFRED H. SMITH & Co.,**DIAMONDS,**

182 BROADWAY,

COR. JOHN STREET, NEW YORK.

33 HOLBORN VIADUCT,

LONDON, E. C.

SEXTON BROS. & WASHBURN,

41 MAIDEN LANE, NEW YORK,

MANUFACTURERS OF

FINE JEWELRY,

INCLUDING A FULL LINE OF MOUNTINGS.



PROMPT AND CAREFUL ATTENTION GIVEN TO SPECIAL ORDER WORK.

DO * YOU * MEAN * BUSINESS?



WE DO

And We are Prepared for It.

WE HAVE ON HAND THE LARGEST STOCK
OF ROUGH AND CUT DIAMONDS AND
FANCY STONES TO BE FOUND
IN THE COUNTRY.



JEWELERS who want fine DIAMONDS or COLORED STONES at FAIR PRICES should make known their wants to us, as we are especially equipped to supply them at short notice with whatever they may need in our line.

L. Tannenbaum & Co.

Diamonds & Precious Stones,

25 HATTON GARDEN,
LONDON.



65 NASSAU STREET,
NEW YORK.

Costly Fire in Providence.

PROVIDENCE, R. I., January 31st.—A fire started from a gas oven just before 4 o'clock this morning in the five story brick building, corner of Stewart and Conduit streets, owned by S. & B. Lederer and occupied by them and two other jewelry firms. The flames broke out on the third floor and burned out the east end of the building, doing considerable damage both above and below that floor. Rovee, Allen & Co., lost about \$10,000, insured for \$17,000; S. & B. Lederer loss about \$20,000 on building, insured for \$25,000, and \$10,000 on stock, covered by insurance. D. F. Adams lost \$1,500, insured for \$10,000. Two hundred and fifty persons were employed in the building.

Quebec and Ontario.

Louis Davis, of Louis Davis & Co., has been in New York on a purchasing trip.

A. A. Abbott, of Smith & Patterson, Montreal, is on a purchasing trip to Boston.

Mr. T. W. Broderick, of London, Ont., has purchased the jewelry stock of Mr. H. Benjamin, of Toronto.

Richard Hemsley's Notre Dame street store will shortly be moved eastward, and will be refurnished throughout.

Mr. F. C. Jost, watchmaker and jeweler, formerly with Mr. Simons, St. Thomas, Ont., has started business for himself in that place.

J. A. Pitt, of P. W. Lewis & Co., Toronto, jobbers of watches and diamonds and manufacturers of jewelry, has been in Montreal for a few days.

A. C. Anderson, of the firm of A. C. Anderson & Co., Toronto, favored Montreal with a visit last week. He was here preparing for spring trade.

A. C. Fitch, president of the American Waltham Watch Co., accompanied by his wife, was in Montreal on a business and pleasure trip recently.

Henry Birks, head of the large jewelry firm at 235 St. James street, Montreal, has just returned from a trip to Chicago on the look out for novelties.

Travelers of J. H. Jones & Co., McGill street, are leaving for all points of the Dominion with fresh samples, and it is expected that they will succeed as usual.

Geo. Chillias, of Toronto, has been in Montreal for a few days. He is a great favorite with the trade on account of his gentlemanly manners as well as his great energy.

Fred Mansfield and Ed. Carlton, Jr., of Smith & Patterson, Montreal, are expected to go on the road for Spring trade shortly. Both are very popular, in the lower provinces and Ontario, where their respective fields lie.

The Montreal Watch Case Co., of Montreal, manufacturers of gold and silver cases are erecting a five-story building on Vitre street which will be occupied when finished by themselves, J. T. Bolt & Co., and Louis Davis & Co., all manufacturers of rolled plate stock.

Syracuse.

JANUARY 31, 1891.

Isaac W. Haight has decided to continue the jewelry business in Auburn, N. Y. He has leased half of a new store in State street and has just opened the new place.

Fred L. Hall the Carthage, N. Y., jeweler, issued a very pretty New Year greeting, in the form of a draft drawn on the "Bank of Prosperity," and issued to the "Goddess of Fortune, State of Prosperity," entitling the holder to 365 happy days in the year 1891. It created much favorable comment among the recipients.

Ithaca, N. Y., jewelers complain that the long sleeves now worn by ladies hurt the sale of bracelets. This should not interfere with the sale of the dainty-jeweled bracelets designed for wear with evening gowns, and should incite the manufacturers to greater efforts in the way of unique patterns.

J. Dean Hawley & Son, jewelers, of New York, have sold their business and fixtures to Frank H. Wells. Mr. Wells has been a member of the firm for the last three years, and will henceforth conduct the business in his own name. General Hawley's reasons for selling his business is his desire for a change from active pursuits. His son, William D. Hawley, will direct his attention to other business which is more to his advantage. General Hawley is next to the oldest merchant in the city, having been located here over forty-six years.

Mr. D. Valentine, for many years identi-

fied with the jewelry interests here is spending a few days at his home in that city. Mr. Valentine retired from business several years ago, and divides his time between his office in New York and traveling on the other side, only going to Syracuse, his home, for occasional visits. He is considered one of the best judges of gems in this country.

Mr. Dougherty, with Sexton Brothers & Washburn, 41 Maiden Lane, New York, called on his Syracuse, patrons last Thursday.

Mr. Hill, representing Williamson & Company, Union Square, New York, was in Syracuse, on Thursday. Williamson & Company exhibit new novelties in a fleur-de-lis pendant made of pearls, showing only a gold edge, and charming brooches in bow knots.

Mr. Crane of the well-known firm of Stroebel and Crane, manufacturers of gold and silver jewelry, in Newark, N. J., was in Syracuse, on Wednesday.

Mr. N. S. Reiss, representing Daniel M. Reed, Greene street, New York, was in Syracuse, on Friday, with a magnificent lot of leather goods for the jewelers' trade.

Mr. E. C. McClelland, the artistic jeweler of this city, has a novelty as a dress watch guard. It is of black gros grain ribbon mounted with gold, and a gold fleur-de-lis for a slide, making one of the richest articles of wear for this purpose ever shown.

Mr. McClelland has a small case, lined with white velvet, and containing nothing but the finest gems, each in a handsome case, mounted in charming conceits as brooches, pendants, necklaces.

The jewelry trade of Montreal regard as important the changes in the house of Edmund Eaves, the Notre Dame street jeweler, established over twenty years. When Mr. Eaves died, about thirteen months ago, there was no one to carry on the business except his young son, J. L. Eaves. The latter threw himself into the breach and has since been pushing things profitably. The retail trade will now be given up and Mr. Eaves will move into rooms in the Temple Building on St. James street, one of the best localities in the city. Here he will boom the wholesale trade. His offices will adjoin those of Mr. A. R. Harmon, Dominion agent for the American Waltham Watch Co. The second floor of the Temple Building is the resort of nearly every jewelry man visiting the city. Mr. Eaves is to be congratulated on getting such a good location. He has just returned from a purchasing trip to New York and Toronto, and will carry a big line.

Ostby & Barton, 80 Clifford street, have issued a handy little pamphlet of designs of solid gold emblem rings, which they are now prepared to furnish to the jobbing trade. These rings are finished in their usual workmanlike style and will undoubtedly command an extensive sale.

The New Trenton Movement.

H.T.G and O. F. S. W.



(CLOSED PLATE.)

No. 60, Nickel, - - - \$3.75
 No. 61, Gilt, - - - 3.50



(OPEN PLATE.)

No. 40, Nickel, - - - \$3.75
 No. 41, Gilt, - - - 3.50

LESS CASH DISCOUNT.

FOR SALE BY

Association Jobbers only.

IMPORTANT NOTICE!

We beg to notify the trade that we have placed on the market a **NEW MODEL**

18-Size, Seven Jeweled, S. W. Nickel Movement,

SURPASSING ANYTHING YET MADE FOR THE PRICE, and to which we invite your attention. These movements possess several new features which offer special advantages to watchmakers. They are Quick Train, Straight Line Lever Escapement, and have Safety Centre Pinions and hard enamel Dials. The barrel can be removed without disturbing the train or stem-winding parts. They are beautifully damaskeened, well finished and attractive in appearance and are **EXCELLENT TIMEKEEPERS. EVERY MOVEMENT FULLY WARRANTED.**

The Best Low Priced Movement in the Market.

FOR SALE BY THE JOBBING TRADE.

Send to your jobber for a sample movement. If he does not keep them, write us and we will furnish you the names of jobbers who do.

TRENTON WATCH CO., Trenton, N. J.



— « OUR » —

Sidewalk * Post * Clocks

ARE

THE MOST PERFECT IN DESIGN

AND THE

FINEST TIMEKEEPERS MADE.

*)

SEND FOR CATALOGUE.

The E. Howard Watch & Clock Co.

BOSTON, NEW YORK, and CHICAGO.

383 Washington St.

41 Maiden Lane.

170 State St.



Chicago.

[From Our Special Correspondent.]

"Our prospects have never been better," said Manager A. L. Smith, of the Geneva Optical Company. "Money may be tight in the East, but we have felt none of the evil effects here. Our factory here, at which we do special work, is crowded with orders. Our factory at Geneva, N. Y., is also running full time. We are getting out many new and improved fittings for opticians."

In the last number of the *Archives of Ophthalmology* there was a very complimentary notice of the Geneva Company's work, written by Dr. Knapp. It was as follows:

"The Geneva Company's lens measure is sure to become popular among oculists, for no one who has once seen it will be slow in adding it, as an almost indispensable supplement to a case. It saves a great deal of time, and is as accurate as it is convenient."

The annual banquet of the Chicago Jewelers' Association will be held at the Auditorium to-morrow night. Business cares will be forgotten and general jubilation prevail. The great success which the affair promises is largely due to the efforts of the banquet committee composed of the following: A. L. Sercomb, of the Meriden Britannia Co.; H. S. Peck, of the Waterbury Clock Co.; John F. Morse, of F. E. Morse & Son; J. F. Talbot, of the Dennison Manufacturing Co.; M. A. Mead, of M. A. Mead & Co.

Swartzchild & Co. have just added a large assortment of jewelers, and watchmakers, supplies. Among other articles they have melters', enamellers' and other new tools. They have been appointed sole agents for Hendrick's chronometer. Mr. Swartzchild says that business was never better.

There is a great fad in Chicago for oxidized silver jewelry and ornaments. All the manufacturers and jobbers are doing much in this line.

F. M. Sproehnle, of F. M. Sproehnle & Co., is in New York buying goods.

The Shader Mfg. Company will open a new manufacturing jewelry establishment shortly.

Richards & Ruterhauser have bought out E. W. Burchard's watch and diamond establishment, 78 State street. Both members of the firm are young men, and wide awake at that.

Mrs. Fairfield, mother-in-law of F. E. Morse died on Monday of last week.

Katlinsky & Gatzert the new firm recently established, are starting in with a boom. They have made application for membership in the National association.

This is the song that the traveling men warble now:

Here's my sample case,
There's my trade.
One is a chestnut
The other's begun to fade,
Soon I'll retire
Never more to drum
The jewelry trade is ausgespielt
And I am on the bum.

Yesterday one of those cranks who go about keeping jewelry clerks from becoming rusty, entered a store in the Palmer House block, and selected \$2,000 worth of diamonds and jewelry. Two hours were consumed, and the salesman was happy. While the stranger was directing where the goods should be sent, a small boy walked in from Dunlap's adjoining store, and requested the purchaser to pay for the derby he wore, and also for the high hat he carried in the box. This the man could not do, so the hat store clerk took the two tiles and departed. The jeweler's clerk sadly put the diamonds and other articles back in the safe, and the large purchaser sadly departed. It was a clear case of attempted flim-flam, but did not work.

M. N. Burchard, manufacturer for Simpson, Hall, Miller & Co., and president of the Chicago Jewelers' Association, has been East in the interests of his concern. He is expected home this week.

H. F. Hahn, of H. F. Hahn & Co., president of the National Association of Jobbers, who went East to take part in the deliberation and preside at the Jobbers' Association meeting, extended his stay until Monday of the current week.

A. Hirsch, of A. Hirsch & Co., has been East for two weeks buying goods. On his way to New York he stopped over at Canton, Ohio, to look over Dueber matters.

J. S. Gatz, the Madison street jobber, who has been seriously ill with pneumonia, is back at his place of business again.

"Tony" Serewicz, local agent for the Dueber-Hampden Co., was called to Cariton last Thursday on business pertaining to their Chicago office. He advised the writer on his return that the complex affairs of his company were being straightened out nicely, and there is not the slightest doubt, but the assignment will be raised in a few days.

B. F. Crossin, of Crossin & Tucker, and his brother Peter, were in town the past week. Although virtually the "last of the Mohicans" their personal popularity and the extreme high standing of their goods insure them heavy sales.

The Chicago College of Horology which has succeeded the Chicago Horological Institute under the management of superintendent Hart, is fast coming to the front as one of the leading schools of horology in this country. Mr. Hart has shown executive ability and is filling the school rapidly with students. He has introduced many new features, such as talented instructors coupled with the latest devices in machinery, and gives every student a splendid opportunity of learning the art of watch making. Another feature of this institution is the teaching of engraving, the department having recently been added. A very noteworthy fact is that this latter branch is being taken up by young women.

M. C. Eppenstein, of the Elgin Watch Case Company, was suddenly summoned to Elgin Friday to attend the bedside of Mrs. Eppenstein's mother, who is critically ill.

The Chicago Watch Tool Company are continually adding to their already large list of tools. New attachments have been put on their already superior engraving block, so that it is now pronounced by the trade the most convenient and handy block on the market. Mr. Heineman has enthused new life into this corporation since he has taken the management.

M. A. Mead, of M. A. Mead & Co., the popular special agents of the Waltham Watch Co., is one of the busiest men in town these days. Officially he is secretary and treasurer of the Chicago Jewelers' Association, and a right smart official he makes. The same personal attention that he bestows upon his rapidly-increasing business is just now being given to all the little details that will make the banquet at the auditorium to-morrow a great success.

Trade promises well in Chicago for the coming year. World's Fair matters have given an impetus to all lines of business, and a profitable stretch of at least three years seems to be before the jewelers.

T. M. Avery, President of the Elgin Watch Company, says that prospects never were better. "The association did not fix prices at its convention," he remarked, "the figures remaining as they were. The meeting was largely in the nature of a social event."

C. K. Giles, manager of Giles, Bro. & Co., predicts the largest trade ever known. "Our business is fifty per cent. in excess of last year," he said in an interview, "and is growing steadily. Our territory in the West and Southwest is growing right along also."

Mr. Lapp, of Lapp & Flersheim, reports great growth in business. Mr. Flersheim was at the recent association meeting appointed executive for Chicago, and to him are referred all local matters relating to the association.

NATIONAL COUNCIL No. 318, Jewelers' Association, elected officers for the ensuing year as follows: President, Dr. George N. West; Vice-President, Walter Buckley; Speaker, J. W. Atwell; Secretary, R. C. Demarest; Financial Secretary, F. C. Ralston; Treasurer, Otto Stumpf; Chaplain, Charles S. Barnes; Usher, W. S. Reed; Sergeant-at-Arms, J. C. Heinold; Doorkeeper, Carl E. Newman; Representatives to Cabinet, W. E. Highley, A. N. Sperry, E. A. Rich; Trustees, C. P. Denyan, J. F. Morse, and A. H. Wittstein.

A Burglary and Three Arrests.

SAGINAW, January 30. At 2 o'clock this morning Police Officer Levan discovered the glass in the back door of Swinton & Reynolds wholesale and retail store had been broken, and that burglars had evidently been at work. The officer went to Mr. Reynolds' hotel and awakened him. The two then hurried to the store and discovered that about \$600 worth of gold pens had been stolen. About an hour later Officers Barron and Cunningham arrested three suspiciously-acting young fellows named Wesley Brown, Nelson Allen and Clarence Donaldson, all residents of this city. They were locked up on a charge of vagrancy.

A Bad Crook From Meriden.

HAMILTON, Ont, Jan. 28.

A Meriden crook, James R. Kennedy, sampled Canadian justice at the police court this morning. Kennedy broke into the Meriden Britannia factory a week ago and was caught by the night-watchman, who found two teapots in his possession. As the prisoner appeared to be respectable, although suffering from a protracted drunk, he was remanded the police wanting to find out what kind of a character he bore in Meriden. Kennedy told the magistrate that he worked for Rodgers Bros. in Meriden. He went to New York in November and worked there for a week. He was a brass-finisher, and came here to look for work. When the magistrate was about to remand the prisoner for another week, Sergt.-Major Smith received a letter from Meriden. It stated that James R. Kennedy, twenty-nine years old, ruddy complexion, blue eyes and red hair had been arrested eight or ten times for drunkenness and theft. He had also been arrested in Wallingford. The police said he was bad all through. The description answered to the prisoner. "What have you got to say about all this?" said the magistrate. "It is not so," said the accused. "I suspected there was something wrong about you when you traveled around so, responded his Honor. "I will send you to Central prison for three months."

Mrs. Lord Wanted.

CHICAGO, January 30.—Mrs. or Miss Lord is wanted by Mayo & Groff, jewelers; Marshall, Field & Co. and James H. Walker & Co., dry goods merchants, and other business men here. It was her practice to trade at these places until she became well acquainted, paying cash for everything she purchased. Then she ran up big bills, and these she neglected to pay, and the police don't know where to find her. She got a diamond valued at \$1,000 from Mayo & Groff, for which she didn't pay, and was allowed to take it home. She hasn't been seen since. At Marshall, Field & Co.'s there is \$2,500 standing against her name, and at J. H. Walker & Co.'s, \$2,300. She has made about \$15,000 in the past two months.

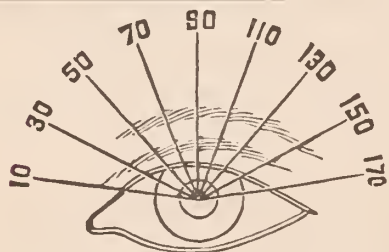

SEND TO

GENEVA OPTICAL CO.

23 Washington St., Chicago,

FOR

PREScriptions, REPAIR AND ORDER WORK PROMPTLY at LOWEST PRICES

SWARTCHILD & CO.,



Our Complete Catalogue, illustrated, will be sent to any one forwarding us their address, free of charge.

We give special attention to mail orders. They are filled promptly the same day that they are received.

76 and 78 State Street, Chicago.



R. A. Kipling

Importer of Precious Stones

31, Union Square
New-York

19, Rue Drouot
Paris

WE WISH TO ANNOUNCE

That our line of Watches and Jewelry is now complete. Our stock is entirely new, and comprises everything pertaining to the legitimate jewelry trade.

CAN WE SERVE YOU?

KATLINSKY & GATZERT,

WHOLESALE JEWELERS,

96 STATE STREET,

CHICAGO.

CHICAGO WATCH TOOL CO.,

52 MADISON STREET, CHICAGO, ILL.,

MANUFACTURERS OF

Staking · Tools, · Foot · Wheels, · Polishing · Lathes

AND ALL KINDS OF

WATCHMAKERS' AND JEWELERS' TOOLS.

Catalogues sent upon application.

Philadelphia.

[From Our Special Correspondent.]

JANUARY 31.

The New York houses were pretty well represented here this week. Among them were Messrs. Benton and MacDonough, with the Courvoisier-Wilcox Company; J. J. Richards, of J. J. & J. M. Richards; W. Carey, with F. M. Whiting & Co.; M. D. Rothschild and Henry Schofield, of Lincoln, Bacon & Co. Other visitors were George Parks, representing the Sterling Co.; John R. Morss, with R. Blackinton & Co., and S. A. Baldwin, representing W. E. White & Co.

The recent increase in the business of H. Muhr's Sons has necessitated an increase of facilities in their manufacturing establishment at Broad and Race streets. One floor of an area of 14,000 feet is devoted to the jewelry department, and the watch case business proper, which previously had but one floor, now requires three floors of 14,000 feet each in area, to accommodate it. The several departments are thus doubled in capacity for the current year.

Stones of four to five carats have been offered in this city lately, which have been artificially colored. It is probably that in the near future there may be some more striking developments in this connection.

Bernard Levy, the South Ninth street watch case manufacturer, who has been very ill for some time past but who is now rapidly recovering, intends to test the merits of the Carlsbad waters in the early Summer. He will sail for Europe in the latter part of May.

The Retail Jewelers' Association met on Wednesday afternoon at their hall on Arch street above Twelfth, but transacted merely routine business.

Jules Levy is preparing for a trip to Pittsburg, Chicago and the West generally, with a new line of his jewelry specialties.

Charles H. O'Brien, of Louis A. Scherr & Co., is steadily recovering from a severe and protracted sickness. Charles Z. Scherr, also with this house, is now dangerously ill. He is superintendent of the large material department of the Scherr establishment, and his place at present is being filled by William C. Williams.

James Franklin, of No. 227 North Eleventh street, was arraigned before Magistrate Pole at the Central Station on Friday last for a hearing, charged about the first of the year. He was held in \$1,000 bail.

ARTIFICIAL EYES!

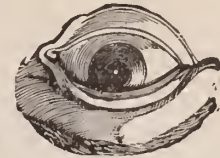

STOCK ORDERS of Selection Packages. Largest Assortment.

GENEVA OPTICAL CO.,
23 Washington St., Chicago.

806 806
HOLLINSHED BROS.

Wholesale Dealers in
American Movements
And **CASES.**

A Big Line of **JEWELRY.**

809 806
CHESTNUT STREET, PHILADELPHIA.

Geneva Optical Co.,
MANUFACTURERS OF Spectacles, Eye Glasses, Lenses and Cases.
23 WASHINGTON ST., CHICAGO.

M. ZINEMAN & BRO.,
MAKERS OF **"DIAMANTA" SPECTACLES** & EYE-GLASSES

130 SO. NINTH STREET, PHILA., PA.

AMERICAN AGENTS FOR

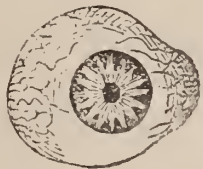

MUELLER'S · ARTIFICIAL · HUMAN · EYES,

IMPORTERS OF ALL KINDS

Opera Glasses and Field Glasses,
FOLDING POCKET OPERA GLASSES.

MAKERS OF ALL KINDS OF

Trial Cases and Instruments for Measuring Eyes
IMPROVED PERFECTION TRIAL FRAME.

Send for Catalogue and Price List.



COMPARE

ALL OTHER GOLD FILLED CASES WITH THE CELEBRATED



CROWN, LION,
EXCELSIOR

HAND ENGRAVED CASES.



WARRANTED

MADE BY

H. MUHR'S SONS, 629-631 CHESTNUT ST., PHILA.

GORHAM MFG. CO.

Silversmiths. SOLID SILVERWARE.



OUR recently completed works at Providence, R. I., are regarded as the most perfect and extensive plant for the manufacture of Silver Ware in the world, and include all the latest improved machinery, much of it peculiar to this establishment. Our corps of employes outnumber any similar establishment in this country or in the world.

Its capacity is for two thousand employes, and we are enabled by these increased facilities in every department to produce unlimited novelties in our line. Our stock now contains the largest and most varied assortment of Solid Silver wares ever presented, and at no time has it been so complete and well filled with novelties from the most inexpensive to the most elaborate and artistic.

HOLLOW WARES.

Our lines of Silver Hollow Ware have been increased by entire new designs in TEA and TETE-A-TETE SETS, SUGARS and CREAMS, AFTER-DINNER COFFEE SETS, TURKISH COFFEE POTS, BERRY BOWLS and SALAD BOWLS.

TOILET GOODS.

We have prepared several new and complete lines of TOILET ARTICLES for the fall trade.

ECCLESIASTICAL DEPARTMENT.

We have enlarged this Department at our works and at Broadway and 19th st., and we are capable of entertaining propositions of any magnitude in this line, and carry an extensive stock for immediate purchase.

LEATHER DEPARTMENT.

Our LEATHER GOODS surpass any that are offered to the Trade, in style, quality, finish and design. The stock contains the newest novelties and in advance of any other lines presented.

Broadway and 19th St., New York.

GORHAM MANUFACTURING CO.'S BRANCH HOUSES:

9 Maiden Lane, New York, * * * * *

137 & 139 State Street, Chicago, Ill.

120 Sutter St., San Francisco, Cal.,

* * * 36 Avenue de l'Opera, Paris, France.

ALL communications should be addressed,

BROADWAY and 19th STREET.

Works: Providence, R. I.

THE JEWELERS' CIRCULAR AND HOROLOGICAL REVIEW.

PUBLISHED EVERY WEDNESDAY BY

THE JEWELERS' CIRCULAR PUB'G CO.,
AT NO. 189 BROADWAY, NEW YORK CITY.

A JOURNAL DEVOTED TO THE INTERESTS OF
WATCHMAKERS, JEWELERS, SILVERSMITHS,
ELECTRO-PLATE MANUFACTURERS AND ALL
WHO ARE ENGAGED IN KINDRED BRANCHES
OF INDUSTRY.

Terms of Subscription, Postage Prepaid.

	PER ANNUM
United States and Canada, - - -	\$2.00
To all Foreign Countries, - - -	4.00
Single Copies, - - - - -	.10

ADVERTISEMENT.

Business letters, drafts, checks and post-office orders should be addressed to THE JEWELERS' CIRCULAR PUBLISHING COMPANY, No. 189 Broadway, New York city.

Manuscript from any quarter containing news or discussion of any technical subject within the field covered by THE CIRCULAR will be welcomed. Matter received that proves unsuitable or unavailable will be returned if accompanied by the necessary postage stamps.

Our editorial columns will contain our own opinions only, and we shall present in other columns only what we consider of interest or value to our readers. Applications to print advertising matter as news will not be considered.

Advertising rates in THE CIRCULAR are lower, considering the number of tradesmen reached by its large circulation, than in any other jewelry journal.

VOL. XXII. FEBRUARY 4, 1891. No. 1.

To Our **W**ITH this issue THE JEWELERS' CIRCULAR begins its career as a weekly news and technical paper.

The success that has attended our work for two decades past is, we are assured, but an earnest of what the future has in store for us.

And yet we are fully aware that the edifice of this success and the favor of our patrons rests simply and solely upon merit. And we wish it to continue so. We depend for the success of our journal upon a continuance of the good work we have done and the untiring efforts we have made for the lifting higher and making better of the retail jewelry trade.

Published at weekly intervals THE CIRCULAR is better adapted than formerly to the collation of news and the propagation of useful ideas, and has more frequent and better opportunities for assisting the trade and keeping its members informed upon current topics. The important features of the reading matter—such as Optics, Workshop Notes and kindred subjects—will still continue in our columns, and other features, impossible to a monthly but quite within the province of a weekly, have been added.

Increase of opportunity means increase of responsibility. It always has been and will continue to be the principle of THE CIRCULAR to recognize opportunity as responsibility and to rise with the one to meet the other. And we pledge our best endeavors, united

with all the facilities known to modern trade journalism, toward making THE CIRCULAR even better than ever before

We extend our thanks to our friends for the many kind words we have received from them recently. Some of these we have found space for in our columns. Such communications are always welcomed at our office, and we look upon them as hand-shakes and greetings from subscribers who are too far away to reach us often *in propria persona*.

Some Important Statistics.

STATISTICS concerning the importations to this country of jewelry, manufacturers' gold, silver and precious stones since 1885, exhibit a marked increase in the value of the amount of imports. During the first eleven months of 1885, these goods were imported to the value of \$7,161,565. During the corresponding period of 1890 the importations of the same goods aggregated \$13,550,876; an increase in five years of \$16,389,311; or 89 per cent. over 1885.

Of course the larger part of these importations are diamonds, and their recent advance in value will account in a measure for a part of the 89 per cent. total increase. Notwithstanding this, however, more actual stones have been imported this past year than in any previous year, and the diamond trade is increasing.

Some of our most prominent diamond importers agree that the prospect is better for this year than ever before and are preparing for a busy trade.

The outlook for a prosperous year is better than it has been for some years previous. Fewer failures are reported for the month of January, 1891, than for the same month in several years back, and everywhere in all branches of industry manufacturers and tradesmen are encouraged. It is plain that if general business is good the jewelry trade is correspondingly prosperous. THE CIRCULAR takes great pleasure in speaking of this happy outlook, and wishes the trade generally the best year in the history to date of the jewelry business.

Something about Silver.

THE prospect of the passage of the Silver Bill has kept jewelers in general and silversmiths in particular in an uncertain mental condition concerning its effect on the price of silver and the consequent effect upon their trade. If the bill should pass, 371¼ grains of silver which now cost eighty-three cents would be worth just one dollar at the United States mint—and so, one dollar everywhere else. In other words, the amount of this metal which is now bought for \$1.03, would then cost \$1.30. The effect upon the trade is obvious, and would be to increase the price in silver wares.

But since the eloquent and masterly address of the late Secretary of the Treasury Windom, emphasized as it was by the sad occurrence which followed, the impression

seems generally to prevail that the bill will not be passed by this Congress at least.

There is no doubt that, as this impression comes to assume the importance of a fact in the minds of our manufacturers, dealers and consumers, the silver market will be steadier and confidence in trade and its prosperity more assured.

A Bright Outlook.

IT is always gratifying to know that business is good and that the outlook is promising. During the holidays some of our dealers complained that they were not doing so much business as they had anticipated and prepared for; some others reported an even larger business than last year. But all over the country, jewelers, watchmakers, silversmiths and importers are speaking of the large amount of trade that they have for the present season, which is usually a slack period.

The reason for the unusual quiet for the holiday season and the briskness that pertains now, is obvious. The stringency of the money market last August induced a lack of confidence and conservatism in money matters that extended through the season in which those who have money to spend buy much jewelry. Confidence seems now to have been restored and people who have been holding their money are ready to spend it. The money market is easier and cash can be had more readily.

A Post-Graduate Opticians' Association.

IN another column we print some of the letters that have been received concerning the school of optics mentioned in the last issue of THE CIRCULAR. A new phase may be given to the project by the proposed organization in this city of another association of graduates of optical institutions. Both questions are yet open to discussion, but it is quite certain that, in any event, such an association is desirable and will be formed.

Diamond Robbing in San Francisco.

January 31.

A statement is published that the diamond palace of Colonel A. A. Andrews was entered some nights ago and over sixty-five diamond lockets and about fifty diamond scarf pins of total value of \$7,500 were taken by burglars from the show case without disturbing the watchman, who was sleeping in the store. Detectives kept the matter quiet and have not yet succeeded in obtaining any clew to the thieves.

He Worked Quickly.

HOMESTEAD, Pa., Jan. 31.—The jewelry store of John F. Schmitt was entered to-day, and \$2,000 worth of diamonds and watches stolen. Mr. Smith locked up his store and went to supper about five o'clock. He was gone only twenty minutes. When he came back he found a large square hole behind the counter, which had been cut through the floor. The store was a new one,

New York Notes.

A. LUDWIG who is well known to the trade as the originator of the well-known curio silver novelties, and who has been designer and superintendent for George W. Sheibler for the last nine years, has opened a factory for the manufacture of sterling silverware, in all its branches for the trade, only at No. 247 and 249 Centre street (Trenkman Building), N. Y., under the firm name of A. Ludwig & Co. His ability and taste are generally recognized throughout the country, and the trade will look for a fine lot of samples from the new factory.

"Little Dave" Cummings, the notorious safe breaker and burglar, is again in the clutches of the law. The principal importance of the arrest is in the breaking up of the gang that he had formed in this city, and in the capture of the thieves, tools, though Cummings got seven years for simply having the latter. Among the exploits which have made "Little Dave's" name known to the trade, was the robbery of a jewelry store in New Orleans, in which \$100,000 worth of diamonds and jewelry were stolen, none of which was ever recovered. In May, 1881, a gang of thieves of which Cummings was an active member, made the acquaintance of a traveling salesman for Enos Richardson & Co., in Baltimore, and relieved him of \$15,000 of goods, of which \$2,500 worth was afterward returned.

T. B. Clark & Co., Honesdale, Pa., manufacturers of cut-glass ware, have opened a spacious show room for the display of their goods in New York at 53 Park Place, where a full assortment of their large line will be kept constantly on exhibition. A new pattern, "The Aron," just from their factory, is pronounced by connoisseurs, one of the finest examples of the art ever placed on the market.

Rodific Rabitte, son of the late Chas. L. Rabitte, of C. L. Rabitte & Co., 437 Broadway, and brother of the present C. L. Rabitte, of that firm, died at Bloomsfield, N. J., on January 30th.

E. Pelikan has moved from 64 Nassau street to 51 Maiden Lane.

Mason & Wilson, manufacturers of gold, silver and plated jewelry, Pawtucket R. I., have opened an office at 76 Franklin street, of which R. M. Buttle has been put in charge.

Victor W. Brundage, of Leroy W. Fairchild & Co., will start on February 7th on a tour through the far West to recuperate his health, which has been somewhat broken for the past few months. He will also look after the interests of his house.

M. A. Gatter has started in business at 31 Maiden Lane.

A prominent figure at the ball of the Palestine Commandery, No. 18, Knights Templar, held at the Metropolitan Opera House, January 29th, was C. G. Braxmar, the well-known medal maker.

T. P. Delany is one of a committee to arrange for a dinner to Judge John Henry McCarthy, in the Hotel Brunswick, on February 16th.

Louis C. Tiffany, of Tiffany & Co., and of the National Academy of Design, has been appointed on a committee to inform the several art societies of the country of a proposed general and retrospective Exhibition of American Art at the Madison Square Garden, to be held in 1892.

Ketcham & McDougall, M. Adler, Maurice Weil, Odenheimer & Zimmern, Veit, Hirsch & Co., Low, Weinburg & Hyman, Bruhl Bros. & Co., N. Y. Standard Watch Co., New York; J. N. Weil & Bros., Buffalo, N. Y.; J. M. Bonnet, Zanesville, O., and E. A. Cowan & Co., Boston, Mass., have been admitted to membership in the New York Jewelers' Board of Trade.

F. Ogden Stout, of the Spencer Optical Co., will, on February 11th, address the National Retail Jewelers' Association at its annual meeting in Philadelphia.

Dr. George S. Horton, one of the best-known ophthalmologists in the country, died on January 3d at his home, 154 West 34th street, of pneumonia. The deceased was born at Great Barrington, Mass., in 1851. He was graduated from the New York Homœopathic Medical College, and had always practiced in New York, making a specialty of ophthalmic diseases. He was a lecturer on ophthalmology at the New York Homœopathic College and senior surgeon and lecture, at the New York Ophthalmic College and Hospital.

The plating works of Louis Krouse at 216 Centre street are advertised for sale

Fred M. Barker, jewelry buyer for Adams & Co., 341 Sixth avenue, died suddenly at his home, 126 W. Twenty-second street, on the night of January 30.

George R. Solomon, metallurgist, claims to have discovered a metal that can be substituted for silver in the manufacture of knives, forks, spoons and watch cases. He says that the compound will not tarnish, cannot be affected by acids, and is of nearly the same weight as silver. The metal, Mr. Solomon says, can be made at a wholesale cost of \$1 per pound.

Frank O. Coombs has retired from the firm of Frank Mauser & Co., silverware manufacturers, 30 Union Square. The business will be continued by Mr. Mauser under the same firm name. A new trade-mark has been adopted which will be stamped on all their goods from this date. Mr. Mauser will call on the trade in person with the new line.

The Mount Washington Glass Co., New Bedford, Mass., will have their annual opening display at their New York store, 46 Murray street, between the fifth and twelfth instances. The display will be in charge of W. H. Lumard and W. F. Martins, and one of its chief features will be the new decorated "Crown Milano," as well as a number of new patterns in cut glass. At about the same date a duplicate of this display will be made at the Tremont House, Chicago, where their western representative, E. J. Koch, will be in attendance.

A. G. Funk, the popular treasurer of the Fidelity Watch Case Co., Corbin Building, was married to-day to Miss Grace Liliendahl, of Stapleton, Staten Island.

New Haven.

[From Our Special Correspondent.]

JANUARY 30.

The managers of the Middletown Plate Company this week adopted the weekly payment system.

A. D. White, the New Haven jeweler, was taken seriously ill last Monday with kidney trouble and is very sick at his residence in this city.

Judge Hubbard, of Wallingford, is one of the invited guests to the annual banquet of the Chicago Jewelers' Association which takes place Thursday evening, Feb. 5th.

Mr. George R. Curtis one of the officers of the Meriden Britannia Company has been bereaved in the death of his sister Mrs. Hallam, of Meriden, widow of the late Rev. Dr. Hallam.

S. C. Bartrom, the Centre street jeweler and silversmith, a few days ago lost by death his aged father, an estimable citizen, and his wife has been for the last two weeks very low with heart disease; but to-day the physician has hopes of her recovery.

C. C. Carroll, of Yalesville, Ct., has got well fixed in his new jewelry store which he opened last week in the Turn Hall, Wallingford. He has many friends in Meriden, Yalesville and Wallingford, and has made a good start, with a prospect for a progressive business.

At the annual meeting of the Shelton Silver Plate Company, a day or two ago, directors were chosen as follows: D. W. Plumb, J. R. Brinsmade, E. S. Brinsmade E. S. Smith, G. H. Peck. And D. W. Plumb has been elected president, E. S. Smith, vice-president, and J. R. Brinsmade, secretary and treasurer.

What came near being a disastrous fire at L. T. Arnold's jewelry store, New Haven, was discovered at one o'clock at night this week by a police officer, who roused Dr. E. S. Gaylord, who lives overhead. A partition was blazing away, having caught fire from an overheated stove. By prompt work the fire was extinguished with slight loss.

Gen. Geo. H. Ford, the New Haven jeweler and wife, were guests at the brilliant wedding in New York last Wednesday, at which Walter L. Bigelow, son of ex-Gov. Bigelow, of Conn., was united to Miss Georger, a daughter of a member of the firm of C. Gunther & Co., New York. General Ford was Commissary-General on the staff of ex-Gov. Bigelow.

The New Haven Clock Company is busy again. President Camp of the Company is still hale and vigorous; "though four score years of age his eyes are not dim, nor his natural force abated." F. E. Morgan, treasurer of the clock company, was last week elected President of the Standard Time Company of this State, which is doing a fine business, last year's reports being especially favorable.

Mr. and Mrs. C. E. Stockder, whose brilliant wedding took place in Meriden recently, have returned from their wedding trip and taken rooms as the guests of Mr. and Mrs. E. H. White, until their pleasant residence in Meriden is thoroughly completed. Mr. Stockder has long been a much esteemed bookkeeper at the Meriden Britannia Company's office.

DORFLINGER'S AMERICAN CUT GLASS.



✱ The Finest Crystal, Plain and Cut, made in the World. ✱

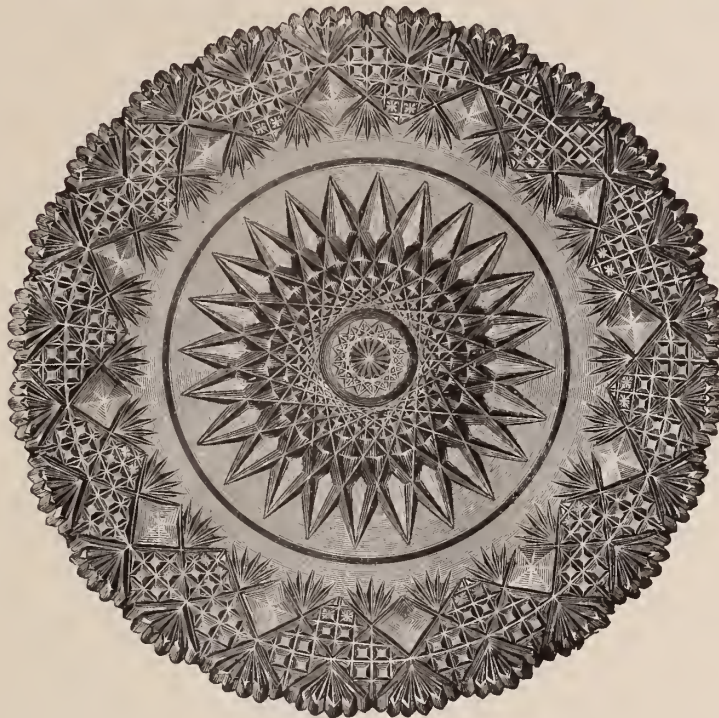

EVERYTHING that is used in Glass, for the Table.

Sells as well as Silver-ware.

EVERY FIRST-CLASS JEWELER

C. DORFLINGER & SONS,

BEAUTIFUL, Artistic and Useful Pieces for Gifts.

Rivals the Diamond for Purity and Lustre.

SHOULD KEEP IT.

36 Murray Street, New York,



ROY



WATCH . CASE . COMPANY.

SPECIALTIES:

Novelties	Raised Gold Ornamentation.	} NEW STYLES	
	Inlaid Gold		"
	Enamel		"

READY.

Staples	Extra Heavy Weight Cases,	} ALWAYS IN STOCK.
	Howard Cases,	
	18 Karat Cases.	

Our Product is one of the Largest. We are able to fill nearly all special orders at once.

OFFICES:

17 Maiden Lane, New York.

220 Sutter Street, San Francisco.

LOUIS DE GOLL,

General Agent

We are glad to renew our acquaintance with the readers of the CIRCULAR, and have taken this fitting opportunity to commence a continued advertisement in it; for it seemed to us that the CIRCULAR, modernized into this weekly form, in some measure reflected our own business ideas in that it unites a proper conservatism with the largest spirit of modern progress—as shown in this latest number.

We beg to engage your careful reading of our advertisement week after week, and we promise that you will benefit with ourselves, in such reading. We have occasionally an extraordinary bargain to offer (next week's issue will show an instance); we often have specially good news concerning new goods, and oftener need to call your attention to our great staples; and in divers ways your interest lies in finding what we have to say in the CIRCULAR, on each recurring Wednesday. We hope to establish ourselves in your good will, and trust that you will shortly feel that there is promise of pleasure and profit in dealing with us.

Bowman & Musser, Importers and Jobbers,

WATCHES, CHAINS, SPECTACLES, TOOLS, MATERIALS.
LANCASTER, PA.

TRADE  J.G.C. & CO. MARK.



Manufacturers of
**FINE
Rolled Plate
CHAINS.**
J. H. Cheever & Co.
North Attleboro, Mass.

TO THE TRADE.

We beg to announce to the Jewelry Trade that we have opened at

No. 53 PARK PLACE, NEW YORK,

a Showroom for the display of our handsome line of

CUT GLASSWARE.

A full line of samples will be kept constantly on hand. Our latest design,

"THE AVON,"

is pronounced by connoisseurs the finest example of the art yet offered to the trade.

T. B. CLARK & CO., 53 Park Place, New York.

OSTBY & BARTON,

SOLID GOLD BAND, STONE

- - AND FANCY RINGS - -



— ALSO A LARGE LINE OF EMBLEM RINGS. —

H. LUDWIG & Co.



NEW YORK OFFICE,
FRESKOTT BUILDING,
ROOM 40. SAMPLES ONLY.

WORKS, BLACKSTONE & GAY STS.
TAKE PRAIRIE AVE CAR

Providence, R.I.

George H. Wilcox, of the Meriden Britannia Company, was this week elected a member of the board of directors of the Meriden Fire Insurance Company, vice his father, the late Horace C. Wilcox; and at the annual meeting of the William Rogers Manufacturing Company, of Hartford, this week, Geo. R. Curtis, of the Meriden Britannia Company, was elected a director vice the late Horace C. Wilcox.

The Derby Silver Company of Shelton, is pushing the work of putting in powerful steam engines and boilers, and expect to be running again shortly with the new equipment. It will be independent of the water-power, which was cut off by the bursting of the big dam of Housatonic river, which entails a loss of \$150,000 to the Housatonic Dam Company and over \$300,000 total loss to that company and the factories and employes in Shelton from loss of time, loss of, or inability to fill orders.

President Watson J. Miller, of the Derby Silver Company, is on an extended pleasure and business trip, accompanied by his wife and two of the company's agents. They left here last Saturday, and during the coming week will be in Chicago. Then Mrs. Miller will visit Texas, New Orleans and Southern California before their return, which will be in about five weeks. The Derby Silver Company's last year of business was one unexampled for prosperity in the company's history.

Hartford.

Henry Kohn is the representative of the jewelry trade who occupies a seat in the Court of Common Councilmen. He ably represents the voters of the First Ward.

The 18th of February will be the second anniversary of the horrible death of Dwight H. Buell, one of the twenty-three victims of the Park Central Hotel explosion. Mr. Buell was one of the leading jewelers in the city. His store was taken by three young men Hausel, Sloan & Co, who are successfully maintaining the reputation made by Mr. Buell.

Ernest Schall, the popular jeweler on the corner of Main and Asylum streets, was one of sufferers by the sweeping order of the Street Board to remove all projecting signs. At considerable expense he had erected a handsome standard clock at the curb, which proved a great convenience to thousands of pedestrians each day. The order went forth and regardless of all appeals the accommodating merchant and tax-payer was given the choice of removing the clock or erasing the inscription "E. Schall." He chose the latter and the clock stands as a city affair, except to the people who know the injustice done to Mr. Schall.

Burdon Seamless Filled Wire Company,

MAKERS OF

The Original and only Genuine and Perfect Seamless
Filled Wires in the World.

SOLD TO ALL MANUFACTURERS ALIKE.



THE SUCCESS of the Burdon Seamless Filled Wire, like that of all important inventions, has been followed by deceptive and imperfect imitations. For the protection of

ALL JOBBERS and RETAILERS,

We authorize manufacturers who so desire, to affix upon the tag, card or label accompanying the articles made from this wire, the following registered trade-mark which is owned by this Company.



The bird-on-wire is a guarantee that the goods are made from the original Burdon Seamless Filled Wire, the reputation of which has been firmly established among the best dealers for more than two years. The perfection and qualities of the Burdon Seamless Wires are always guaranteed. **All Dealers** (jobbers and retailers alike), should, therefore, demand goods made from the original Burdon Wire, and avoid imitations which are offered as "just as good."

BURDON SEAMLESS FILLED WIRE CO.

109 to 119 and 127 Summer St.,

PROVIDENCE, R. I.

CLASSIFIED INDEX TO ADVERTISEMENTS.

All Advertisers are entitled to one insertion under proper heading. Extra insertions, \$6.00 per Annum. Extra Headings, \$12.00 per Annum.

	PAGE.		PAGE.		PAGE.
Assayers & Refiners.		Gas Engines.		Spencer Optical Co., 15 Maiden Lane, New York.....	2
Howard, S. P., 8 John street., New York.....	64	Schleicher, Schumm & Co., Philadelphia, Pa....	37	Zineman M. & Bro., S. Ninth street, Phila., Pa.....	32c
Schawel, John & Co., 29 John street., New York.....	51	Gold Jewelry.		Order Work.	
Auctioneer.		Bipart & Co., Newark, N. J.....	49	Maxheimer & Beresford, 3 Maiden Lane, New York.....	
French, J. H., Box 2775, New York City.....	61	Carter, Sloan & Co., 15 Maiden Lane, New York.....	57	Pens, Pencil Cases, Etc.	
Black Onyx Jewelry.		Cottle, S. Co., 860 Broadway, New York.....	24	Aikin, Lambert & Co., 23 Maiden Lane, New York.....	24
Lawson & Van Winkle, 11 Maiden Lane, New York.....	42	Jonas, Dorst & Co., Race street, Cincinnati, O.	8	Ring Makers.	
Woglom, Gilbert T., 32 John street., New York.....	44	Larter, Elcox & Co., 41 Maiden Lane, N. Y....	43	Bowden J. B. & Co., 192 Broadway, New York ..	21
Badges, Medals, etc.		Riley, John A., 860 Broadway, New York.....	42	Bryant, M. B. & Co., 10 Maiden Lane, New York.....	12
Stockwell, E. R. 19 John street., New York....	37	White, W. E. & Co., 53 Page street, Providence, R. I.....	44	Haskell, H. C., 192 Broadway, N. Y.....	36
Books, Stationery, etc.		Kremetz & Co., 182 Broadway New York....	39	Hildreth Mfg. Co., 51 Maiden Lane, New York.	49
Challon, Howard, 10 Spruce street, N. Y.....	47	Miller, James W., 37 Union Square, New York	27	Hutchison & Huestis, 185 Eddy street, Providence, R. I.....	16
Chicago Envelope Clasp Co., Chicago, Ill....	58	Moore & Horton, 11 Maiden Lane, New York.	51	McCall & Newman, 625 Arch street, Phila., Pa.	56
Dickie, W. B., 69 William street., New York... 56		Owen, G. & S. & Co., 3 Maiden Lane, New York.....	21	Ostby & Barton, 80 Clifford street, Providence, R. I.....	32h
Bronzes.		Gold & Silver Platers.		Wood, J. R. & Sons, 14 John street, New York.	24
Muller Bronze Works, Cor. Underhill & St. Marks Ave., Brooklyn, New York.....	25	Bantle, A., 89 Nassau street, New York.....	24	Wodiska Julius & Co., 49 Maiden Lane, New York.....	39
Chronometer Makers.		Empire Plating Works, 75 Nassau street, New York.....	56	Rolled Plate Chains.	
Heinrich, H. H., 14 John street., New York....	49	Newman, Louis Jr., 36 John street, New York..	55	Cheever, J. G. & Co., No. Attleboro, Mass.....	32h
Clock Dealers.		Worcester & McDonald, Friendship street, Providence, R. I.....	49	Hamilton & Hamilton, Jr., 7 Eddy street, Providence, R. I.....	15
Cooke, B. J.'s Sons, 137 N. 3d street, Phila., Pa.....	46	Gold Chains.		Kent & Stanley, 7 Eddy street, Providence, R.I.	3
Clock Manufacturers		Beck, J. & Son, 10 Liberty street, New York... 56		Rolled Plate Jewelry.	
Howard, E., Watch & Clock Co., 41 Maiden Lane, New York.....	32	Rickert & Stiehle, Newark, New Jersey.....	51	Crossin & Tucker, 409 Pine street, Providence, R. I.....	16
Schlenker, E. R., Schwenningen on Neckar, Germany.....	53	Horological Schools.		Foster & Bailey, 60 Richmond street, Providence, R. I.....	20
Waterbury Clock Co., 10 Cortlandt street, New York.....	40	Chicago College of Horology, Chicago, Ill....	46	Plainville Stock Co., Plainville, Mass.	58
Cut Glass.		Waltham School of Horology, Waltham, Mass.	51	Ludwig, H. & Co., Providence ..	32h
Clark, T. B. & Co., 53 Park Place, New York.. 32h		Jewelry and Silverware Cases.		Seamless Wire.	
Dorflinger, C. & Sons, 36 Murray street N. Y... 32g		American Morocco Case Co., 9 Bond street, N. Y.....	62	Burdon Seamless Filled Wire Co., 109 Summer street, Providence, R. I.....	33
Mt. Washington Glass Co., New Bedford, Mass. 46		Auffermann & Co., E. Forty-second st., N. Y... 14		Settings & Galleries.	
Diamond & Precious Stone Importers.		Vaffer, S. & Co., 66 Nassau street, N. Y.....	56	Blancard & Co., 36 John street, New York.....	47
Fera, Henry, 10 Maiden Lane, New York.....	56	V. Schwarz, 866 Broadway, N. Y.....	51	Show Cases & Fixtures.	
Goldsmith, Herman, 33 John street, New York.	56	Jewelry Repairers.		Smith, B. & W. B., 220 W. 29 street, New York.	64
Hirschberg, Sig., 76 Nassau street, New York.	47	Wiederhold, A., 20 Maiden Lane, N. Y.....	44	Silk Guards.	
Hedges Wm. S. & Co., 170 Broadway, N. Y.....	45	Jewelers' Scales.		Rosentall, Wm., 79 Nassau street, N. Y.....	47
Kahn, L. & M. & Co., 10 Maiden Lane, N. Y.	64	Troemner, H., 710 Market St., Phila., Pa.....	58	Silver Plated Novelties.	
Kipling, E. E., 2 John st., New York.....	60	Jobbers, Watches, Diamonds, etc.		Barstow & Williams, Providence, R. I.....	49
Oppenheimer Bros., & Veith, 35 Maiden Lane, New York.....	45	Bowman & Musser, Lancaster, Pa.....	32h	Silver Plated Ware.	
Randel, Baremore & Billings, 29 Maiden Lane,	43	Conover, D. F. & Co., Cor. Chestnut & 7th streets, Philadelphia, Pa.....	5	Middletown Plate Co., Middletown, Conn.....	13
Smith, Alfred H. & Co., 182 Broadway, N. Y....	29	Hennegen, Bates & Co., Baltimore, Md.....	44	Meriden Britannia Co., Meriden, Conn.....	19
Tannenbaum & Co., L., 65 Nassau street, New York.....	30	Katlinsky & Gatzert, 96 State street, Chicago.. 32b		Pairpoint Mfg. Co., New Bedford, Mass.....	5
Wood, C. F., 169 Broadway, New York.....	63	Koch & Dreyfus, 22 John street, New York....	53	Rogers & Bro., 16 Cortlandt street, New York, 40, 10	
R. A. Kipling, 860 Broadway, New York.... 32b		Keller, L. H. & Co., 64 Nassau street, New....	55	Rogers, Wm., Mfg. Co., Hartford, Conn.....	42
Diamond Cutters.		Myers, S. F. & Co., 48 Maiden Lane, New York.	64	Wallace, R. & Sons Mfg. Co., Wallingford, Conn.....	6
Groeneman, A. J. & Co., 80 Nassau st., N. Y....	51	Schwab, A. G. & Co., Cincinnati, Ohio.....	58	Sterling Silver Jewelry.	
Diamond Jewelry.		Yates, John B., Times Building, New York....	35	Blackinton, R. & Co., North Attleboro, Mass..	35
Brooks & Pike, 383 Washington street., Boston,	39	Beguelin, Tell A., 71 Nassau street, N. Y.....	53	Sterling Silver Novelties.	
Falkenau, Oppenheimer & Co., 40 Maiden Lane, N. Y.....	64	Cross & Beguelin, 21 Maiden Lane, N. Y.....	52	Alvin Mfg. Co., 860 Broadway, New York.....	38
Nissen, Ludwig & Co., 18 John street., N. Y....	14	Friedlander, R. & L., 65 Nassau street, N. Y....	45	Lewis Bros., 41 Maiden Lane, New York.. . .	38
Stern Bros., 42 Maiden Lane, N. Y.....	44	Hollinshead Bros., 806 Chestnut street, Phila., Pa.	32c	Sterling Silverware.	
Sexton Bros. & Washburn, 41 Maiden Lane,	29	Lorsch, Albert & Co., 37 Maiden Lane, N. Y....	64	Durgin, W. B. Concord, N. H.....	42
Engravers and Designers.		Nordman Bros., San Francisco.....	56	Gorham Mfg. Co., 19th st. & B'way New York.	32d
Bartholomew & Peckham, 16 Spruce street., New York.....	58	Scott, J. T. & Co., 4 Maiden Lane, N. Y.....	8	Ludwig, A. & Co., 247 Centre street, New York	36
Ryder & Dearth, 146 Westminster street, Providence, R. I.....	62	Swartchild & Co., Chicago, Ill.....	32b	Mauser, F. & Co., 30 Union Sq., N. Y.....	38
Eye Glass Holders & Chains.		Masonic Emblems and Charms,		Shiebler, Geo. W., 6 Liberty Place, New York.	27
Merritt, S. F., Springfield, Mass.....	51	Richardson, J. W. & Co., 196 Broadway, New York.....	8	Smith, Frank W., Gardner, Mass.....	40
Fancy Goods, Bric-a-Brac, Etc.		Mexican Onyx Goods.		Towle Mfg. Co., Newburyport, Mass.....	60
Taylor & Bro., 860 Broadway, New York.....	42	Kluber, S. & Co., 47 W. Forty-second street, New York.....	42	Wood & Hughes, 16 John street, New York....	24
Filigree Jewelry.		Musical Boxes.			
Hartmann, Peter, 36 Maiden Lane, New York.	47	Jacot & Son, 298 Broadway, New York.....	62		
		Optical Goods.			
		Geneva Optical Co., 23 Wash'n st., Chicago, 32c, 32b			
		Levy, Dreyfus & Co., 11 Maiden Lane, New York.....	8		
		Scheidig J. & Co., 43 Maiden Lane, New York.	36		

Tool Manufacturers.	PAGE.
American Watch Tool Co., Waltham, Mass....	63
Chicago Watch Tool Co., Chicago, Ill.....	32b
Bullock, O. W. & Co., Springfield, Mass.....	37
Logan, A. J. Waltham, Mass.....	50
Waltham Watch Tool Co., Springfield, Mass..	37
Typewriters	
Wyckoff, Seamans & Benedict, New York....	47
Watch Companies.	
American Waltham Watch Co., 5 Bond street, New York.....	23
Illinois Watch Co., 192 B'way New York.....	25
Non-Magnetic Watch Co., 177 B'way, New York.....	61
Stop.....	64
Trenton Watch Co., Trenton, N. J.....	31

Watch & Clock Oils.	PAGE.
Nye, Wm. F., New Bedford, Mass.....	50
Watch Keys.	
Kendrick & Davis, Lebanon, N. H.....	49
Watch & Clock Dials.	
Waltham Dial Co., Waltham, Mass.....	55
Watch Case Manufacturers.	
Essex Watch Case Co., Chestnut street, New- ark, N. J.....	60
Jeannot & Shicbler, 20 Maiden Lane, New York.....	27
Roy Watch Case Co., 17 Maiden Lane, New York.....	32c
Wadsworth & Co., Newport, Ky.....	54
Muhr's Sons, H., 629 Chestnut street, Phila., Pa.	32c
Weis & Oppenheimer, 192 Broadway, New York.....	14

Watch Case Repairers.	PAGE.
Felix N. J., 71 Nassau street, New York.....	62
Henry, Peter, Cincinnati, Ohio.....	58
Goll, Henry & Co., 6 Liberty Place, New York.	47
Watch Importers.	
Abry, Chas. Leo, 41 Maiden Lane, New York.	45
Hyde's Sons, J. E., 20 Maiden Lane, New York.	60
Mathey Bros., Mathez & Co., 14 Maiden Lane, New York.....	47
Wittnauer, A., 30 Maiden Lane, New York....	59
Welded Steel.	
Chrome Steel Works, Brooklyn, New York.	49
Watch Repairers.	
Simmonds, J. C., 18 John street, New York.	47

Special Notices.

Situations Wanted.

THE JEWELERS' CIRCULAR has a guaranteed circulation of over 10,000 copies weekly. It is, therefore, the best medium for reaching the trade. To demonstrate this to advertisers, notices in this column will be inserted free of charge during the month of February.

WANTED.—By a young man of experience, and now in the retail jewelry business, a position with a wholesale house dealing in precious stones or jewelry, or with a manufacturer of fine mountings. In office or to travel. Highest references, given. Age 28 years. Address G. H. C., care JEWELERS' CIRCULAR.

YOUNG MAN who understands hard soldering and can do clock-work and watch-work when not complicated, would like to get a position with a first class watchmaker and finish trade. Temperate, honest, industrious and does not use tobacco. Expects a reasonable salary to commence. Have good mechanical ideas. Some tools. Address. F. E. Hackett, Box 476, Baton Rouge, La.

WANTED—SITUATION by a watchmaker with seven years' experience; furnish own tools and is considered a good salesman; would travel for some jobbing house. Address X. Y. Z., care THE JEWELERS' CIRCULAR.

WANTED—A POSITION by a first-class manufacturing jeweler and diamond setter of nine years' experience. At references from present employer. Address A., care THE JEWELERS' CIRCULAR.

WANTED—A POSITION AS TRAVELING salesman, by a young man well up in the jewelry business. Well acquainted with Western and Texas trade. A good hustler. Well recommended. Address B., care THE JEWELERS' CIRCULAR.

POSITION WANTED—By an experienced and A1 traveling salesman; good references given. Address H. F., care THE JEWELERS' CIRCULAR.

WANTED.—Position by a first class watchmaker, clockmaker, jeweler, and repairer of musical toys, etc. Can put my hands to any variety of repairing work. Have had thirty years' experience; can furnish best of references and security if desired. Would prefer a position in New York City or near-by town. Address, D. H. J., care THE JEWELERS' CIRCULAR.

WANTED.—Situation as traveling salesman with reliable manufacturing or jobbing firm. Will carry any line connected with the jewelry business. Good reference, no bad habits, and a hard worker. Seventeen years in the retail business. Address, C. L. James, 17 14th street, Toledo, O.

Help Wanted

WANTED.—A first-class watchmaker and engraver. State age, experience, salary expected. Can give to right party a desirable position. Address, Theo. L. Rogg, Des Moines, Ia.

CLOCK MAKER WANTED.—To attend to outside work. State experience, references and salary. Permanent position to a satisfactory man. Bailey Banks Biddle, 12th and Chestnut streets, Philadelphia.

WATCH MAKER WANTED.—A young man, good workman, aged about 25 years, to regulate watches; must have good references. State salary expected. A permanent position to the right man. Bailey Banks Biddle, 12th and Chestnut streets, Philadelphia.

WANTED.—A first class, theoretical watch maker to take charge of material department of a New York house. Permanent position, good salary. Address, Watchmaker, care THE JEWELERS' CIRCULAR.

WANTED.—A few traveling men who are practical watchmakers, and have the time—to call the attention of the craft to the Mosely Lathe and Attachments, through the East and Southwest. Address, Mosely & Co., Elgin, Ill.

WANTED.—By a wholesale optical house an experienced salesman acquainted with Western trade. Only such applications stating references, age, experiences and expectations will be considered. Address, A. B., care of THE JEWELERS' CIRCULAR.

WANTED.—To correspond with a traveling salesman in the jewelry trade with a view to introducing a valuable article in connection with his regular business. Address Rex, care of JEWELERS' CIRCULAR.

WANTED.—A YOUNG MAN (single) who understands lathe work, engraving and the business in general. Want a man of good habits; must give good references. Address H. S. W, care THE JEWELERS' CIRCULAR.

Business Opportunities.

A CHANCE OF A LIFETIME.—The advertiser has a farm of 160 acres in Nebraska, which he will exchange for watches, jewelry and diamonds. The location is very good. Full description will be furnished upon application. Address, G. A. Lockwood & Son, Chariton, Iowa.

FOR SALE.—In one of the most rapidly growing manufacturing towns in Pennsylvania. Fine new stock of watches, clocks, jewelry material and fixtures. Trade well established and growing, plenty of bench work. Low rent. Practically no opposition. Will invoice about \$6,500. Stock can be reduced, good reasons for selling. Address, Pennsylvania, care THE JEWELERS' CIRCULAR.

FOR CASH.—A rare bargain, tools, material, and good will of leading repair shop, in a healthy, prosperous, county seat. Two railroads, fine schools, nice stock; would pay handsomely. Particulars on application. W. A. Bethel, Thomaston, Georgia.

FOR SALE.—Stock of jewelry and fixtures in a booming Iowa town. Stock will invoice from \$3,000 to \$3,500; can be reduced to suit buyer. As a special inducement a cash discount of ten per cent. from actual invoice prices will be allowed. Bench work will average from \$75 to \$100 per month. General business of 1800 over \$5,000. Will guarantee to any man who understands his business, a net profit over all expenses of from \$1,000 to \$1,500 per year. No competition nearer than 12 and 18 miles. This is really an opportunity not to be neglected or passed without investigation by a jeweler who cares to make money. Satisfactory reasons given for selling. Correspondence solicited and reliable references given. W. D. Brotchie, Shethfield, Franklin Co., Iowa.

For Sale.

FOR SALE.—1/2 Whitcomb Lathe, Webster wheel, universal head slide rest, Beach & Snyder chuck, and a full line of split wire chucks, counter shaft, etc. Will be sold cheap. B. H. Cosby, jeweler, Asheville, N. C.

To Let.

TO MANUFACTURING JEWELERS AND OTHERS.—A floor to let in the new improved factory building, corner St. Marks and Underhill avenues, Brooklyn. Fine light, power and all modern improvements; within twenty minutes of the Brooklyn ferries. Apply to Geo. W. Shiebler, 8 Liberty Place, New York City.

WORK SHOPS to let in the large, new fire-proof building 29 and 31 Gold street, near John street, New York. Excellent light, steam heat, fire-proof vaults, solid floors, elevator, power in abundance. Apply to Chas. S. Platt, 31 Gold street.

Miscellaneous.

W. A. SCHROETER, 198 Grand street, New York City. Estimates rendered on any desired job. Four expert watch repairers employed specially for Trade Work. Guaranteed finely finished at low prices. Also a good chance for a young man to study watchmaking.

FLEUR DE LIS BROOCHES.

ALSO A FULL LINE OF
STERLING .: SILVER .: JEWELRY,
INCLUDING

Love Locketts, Brooches, Lace Pins, etc.,
And also in first quality Rolled Plate.

R. BLACKINTON & CO.,

New York Office, No. Attleboro,
182 BROADWAY, MASS.

J. R. MORSS.

WATCHES

JOHN B. YATES,

147 NASSAU STREET,
NEW YORK.

SPECIALTY: UNITED STATES WATCHES.



Boston.

January 31.

The creditors of Messrs. Max Newman & Co., jewelers, 15 Avon place, have accepted an offer of 30 cents on the dollar. Mr. Johnson, one of the firm, will continue the business for the present. Mr. Newman, who is suffering from nervous prostration, is at a private retreat for nervous patients in another part of the State. The principal indebtedness is to Providence parties, and settlement was effected through the Providence Jewelers' Board of Trade represented by counsel here. The liabilities amount to about \$13,000.

Mr. George H. Richards, Jr., has passed the danger point of his severe typhoid attack, and will probably be able to attend to business again by the 1st of March.

The Boston Jewelers' Club will hold its annual meeting for the election of officers and transaction of routine business on the 10th Feb. At this meeting plans will be perfected for the annual ladies' night banquet at the Hotel Vendome, which takes place later in the month.

A meeting of the Committee on By-laws of the Jewelry Travelers' Association of New England, the newest of the organizations in the trade in this section, was held Jan. 24 at the American House. This association was organized on the 22d of last December, and elected Mr. Daniel Stevens, president; Mr. John L. Shepherd, vice-president; Mr. H. F. Hayes, secretary; and Mr. William S. Robinson, treasurer. The by-laws drafted by the committee state that the name shall be "The Jewelry Travelers' Association of New England," and the object of the members is "to bring about a better acquaintance of the traveling salesmen in the trade." Meetings are to be held semi-annually, and the article on membership states that "any traveler, not an employer, in the jewelry or kindred trade, is eligible on payment of one dollar for membership and one dollar for annual dues."

Mr. J. F. Safford, the Farmington, N. H., jeweler, is in Boston, taking a course in practical ophthalmology.

The partnership heretofore existing between Messrs. George H. Richards, Jr., and Charles E. Richards, under the name and style of George H. Richards, Jr., & Co., ex-

pired by limitation on the 31st of January, Mr. Charles E. Richards retiring. The business will hereafter be conducted by Mr. George H. Richards, Jr., the old firm name being retained.

Mr. C. S. McLeod, of Amherst, N. S., has been in Boston buying goods to fill up the gaps in his stock made by a rush of holiday trade. He reports business good in the Provinces during the past year.

Mr. John L. Nudd has severed his connection with D. C. Percival & Co.

Mr. Gallagher, representing Sinnock & Sherrill, of New York, has been in town within the week.

Boston jobbers are busy taking stock. Some of the retailers wait till February also, before beginning their annual overhauling of goods.

The French clock main-spring winder, for which a patent has just been issued to Mr. A. R. Vaughan, of Pawtucket, will soon be on the market, says Mr. John T. Fields, who is interested in the venture with Mr. Vaughan. Mr. Fields is with Floyd, Pratt & Co. of this city. Smith & Patterson bade godspeed Monday to nine of their live a young men, all provided with an entire change of samples. Five of them, Messrs. Carl D. Smith, Frank H. Elliot, Charles



A. LUDWIG & Co.
Silversmiths,
(TO THE TRADE ONLY)

247 & 249 Centre St.,
TRINKMAN BUILDINGS
NEW YORK.

A. LUDWIG, for the past 9 years Designer and Superintendent for George W. Shiebler.

Silver Novelties a Specialty. Designs and Estimates Cheerfully Furnished.

JOHN SCHEIDIG & Co.
IMPORTERS AND MANUFACTURERS OF

OPTICAL



GOODS

43 MAIDEN LANE, NEW YORK.

A FULL line of Gold, Steel and Aluminum American Spectacles and Eye Glasses of latest and special designs. Imported and American Lenses. We also control the following brands of OPERA AND MARINE GLASSES: La Favorite, Colmont, Lemaitre, College d'Optique.

SEND FOR
ILLUSTRATED CATALOGUE.

LEMAIRE OPERA GLASSES.



NEW DESIGNS

Class-Rings
and Pins.

RaZZle **PuZZle** "Medal very satisfactory."

DaZZle "They are now beautifully made in sterling silver and gold."

"Goods give entire satisfaction, well satisfied"

OPEN Rings made by Haskell, New York. The surprising popularity of this ring is the phenomena of the day. Everybody is buying them. This novelty has created quite a sensation - Jewelers Weekly

NOVELTIES IN GOLD AND SILVER "The young ladies are delighted with Class Rings"

"Many thanks for rushing work ordered."

"Class Rings gave splendid satisfaction"

Special Designs sent upon request

"Received in good order, Pin, which is VERY satisfactory. We wrote yesterday for sample Class Ring and hope to get that order also"

HENRY C. HASKELL,
MAKER OF FINE JEWELRY,
11 JOHN STREET, NEW YORK.



COPYRIGHT PLATES
Sent to Dealers
upon request

T. Derry, George H. Stanford and T. B. Hennigar, take the New England circuit; Messrs. Fred H. Mansfield, Edward W. Carleton and A. A. Abbot have crossed the northern border, and will display their wares to admiring subjects of the queen; and Mr. C. W. McLaughlin has a palm leaf fan and linen duster in his grip, for he is headed toward the sunny South.

Opticians Organizing.

A PRELIMINARY meeting of opticians was held on the evening of January 27, at 232 East 23d street, for the purpose of organizing an association to be known as the National Association of Opticians. F. Ogden Stout, of the Spencer Optical Manufacturing Company, was chosen chairman and M. H. Rosenblatt, of James A. Hearn & Co., secretary *pro tem*. The object of the proposed association is primarily the mutual advancement of the interests of its members, and in general of the optician's profession—that is, a profession dealing with a subject in which transparent substances and their action upon light are the factors, and in which there are no medical treatments nor physical operations.

The present members, among whom besides the above, are Frederick Whiteacre, Frank Levison, C. D. Bartlett, of New York, and Carlos M. Barnes of Enosburg, Vt., are enthusiastic, and feel that with a large membership, the members will derive inestimable benefit. It has been resolved that only those who carry on the business of opticians, or are graduates of an optical school, or who have studied the science of optics and employ it as a means for gaining a livelihood shall be admitted. Periodical meetings, perhaps monthly, will be held, at which papers will be read, peculiar cases in the experience of the members submitted for discussion, and other matters of a didactic character talked over.

It was decided to hold a meeting on the evening of February 5, for the adoption of a constitution and by-laws, and for the election of officers. Opticians are requested to attend. Secretary Rosenblatt will be pleased to answer all communications. It was decided to constitute the JEWELERS' CIRCULAR the official organ of the Association.



"GET THE BEST."

American Tools are the Best.

O. W. BULLOCK & CO.,

Springfield, Mass.

Manufacturers of **WATCH TOOLS.**

LARGEST LINE IN THE UNITED STATES.

Send 4 cents for postage on new catalogue.

Send for our New and very complete Illustrated Catalogue

OF THE

HOPKINS LATHES

AND ATTACHMENTS.

The best line of Attachments.

THE GREATEST ACCURACY IN ALL ITS PARTS.

Beauty in Design and Finish.

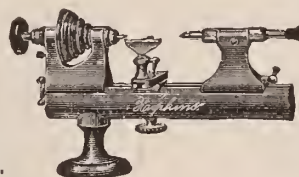

OUR 3 x 4 Lathe has the greatest chuck capacity, and in all the features that go to make up a perfect lathe, it stands at the head.

Don't throw your money away on cheap or imported lathes, when you can get first-class Standard American Goods, guaranteed by makers of long experience, at their present low figures.

Remember that a lathe which is not true is a poor tool at any price.

Address,

WALTHAM WATCH TOOL COMPANY,
SPRINGFIELD, MASS.

KINDLY MENTION THIS PAPER WHEN ORDERING.

OTTO GAS ENGINE WORKS

SCHLEICHER, SCHUMM & CO.

PHILADELPHIA.

CHICAGO.

20,000 SOLD.

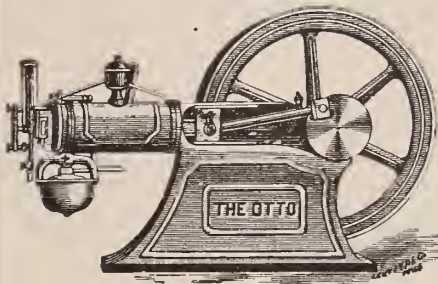

Guaranteed to consume 25 to 75 per cent. less Gas than ANY other Gas Engine doing the same work.

Our 1-horse power engine is largely used by Jewelers.

Price recently reduced to \$325 at Factory in Philadelphia.

Send for Circular and Reference List relating to this Size.

E. R. STOCKWELL,

19 JOHN ST., NEW YORK,

MANUFACTURER OF

Badges and Medals in Gold and Silver,

FOR ALL SOCIETIES,

MASONIC,

INCLUDING

ODD FELLOWS,

GRAND ARMY.

ALSO FOR SCHOOLS.

ENAMELING AND REPAIRING FOR THE TRADE.



Providence.

The annual ball of the First Light Infantry Regiment of this city is always one of the most fashionable social events of the year. This year it will occur on the evening of February 9. Among the members of the various committees are the following well-known jewelers of this city: Lieut.-Col. Christopher Duckworth, Judge Advocate Thomas A. Jencks; Capt. Herbert S. Tanner, Corp. Isaac J. Giddings and Corp. Charles Fletcher on the reception committee.

The presentation and collection of single silver spoons having become very popular. Tilden, Thurber & Co., of this city, have added to their stock several new and unique designs, several of which are of historical as well as artistic value, among them being the Providence souvenir spoons. The State shield, views of the First Baptist Church, built in 1777, the Betsey Williams' cottage and the Providence City Hall are etched on the handles in addition to the word "Providence" in the bowl. In addition to these they have the Salem "Witch Spoon," made by Mr. Low, of Salem, Mass., and the Newburyport spoon "Lord Timothy Dexter," Newburyports' well known celebrity, whose fame, by reason of his warming pan and eccentric speculations, has become world-wide.

Patt, Kettlety & Co, is the name of a new firm which has started in the manufacturing jewelry business at 30 Page street, having purchased the shop, tools and fixtures of the late firm of J. C. Lewis & Co. The firm is composed of William M. Patt, George H. Kettlety, Louis Kern and Herman Kern. Mr. Patt has been a tool maker for nearly a quarter of a century, being last employed by Hamilton & Hamilton, Jr. Mr. Kettlety is an engraver by trade and has had for several years charge of the engraving and designing department of Peter & Bailey; Herman Kern, who will act as foreman of the shop, having been foreman for Smith & Greene for six years, and Louis Kern, one of the best pattern makers and designers in the country who came from the shop of Hamilton & Hamilton, Jr.; Mr. Kettlety will represent the firm on the road.

Considerable interest is being manifested among the business men of this city in the

proposed new post office, for which an appropriation bill is now pending before Congress. Representatives from every commercial organization of Providence visited Washington the past week in the interest of the project. The party was joined at Washington by Dutee Wilcox, President of the New England Manufacturing Jewelers' Board of Trade of this city.

Hamilton & Hamilton, Jr., the rolled plate chain manufacturers, 7 Eddy street, were so driven with orders this year that the customary annual shut down had to be dispensed with. The opening of the spring season finds them with largely-increased facilities and with a determination to tax these facilities to the utmost during the coming year. In point of quality and finish the H. & H. chains long ago were accorded the highest rank, nor has the increase in the business of the firm involved any sacrifice of these qualities wyatever. They are now manufacturing a 14-karat seamless chain, which they claim to be the only one known to them in the market. Their representatives, Robert M. Hamilton, in the East, and R. G. Schutz, in the West, are booking some very large orders this season. The latter will shortly make a European trip in the interests of the house.

The history of the jewelry industry in Providence affords few parallels in point of remarkable increase in business to the firm of Barstow & Williams, 14 Fountain street, manufacturers of silver-plated novelties. The secret of it undoubtedly lies in the fact that this firm have wisely concentrated their efforts upon a popular line of goods, and have not ceased to advertise the same. The patterns they make in all the different articles of their manufacture are simply legion. If the trade do not find what they want in this mammoth line of samples, they must be hard to suit indeed. If such should be the case, however, Barstow & Williams will make anything wanted in their special line.

About a month ago Mr. Levi L. Burdon, of the Burdon Seamless Filled Wire Company of this city, returned from a three months' visit to Europe. Shortly after his arrival he was the surprised recipient of a package from England which upon being opened was found to contain a souvenier in the form of a solid silver match box that is undoubtedly one of

the most artistic pieces of enamelling yet seen in this vicinity. The donor was Mr. I. E. Shaw, an expert in artistic enamel work, of Birmingham, England. The face of the box is of white enamel adorned with a purple violet, and a tiny bird in natural colors perched pertly on a branch made from a piece of the seamless filled wire, of which Mr. Burdon is the inventor, patentee and manufacturer. On the reverse are the American and English national colors, suspended above and tastefully draped around a Staffordshire nut, the whole forming a unique as well as handsome present.

LEWIS BROTHERS,
Easter Novelties in Silver,
41 Maiden Lane, N. Y.

ALVIN MFG. CO.,
Silversmiths,
860 Broadway, New York,
206 Kearney St., San Francisco.

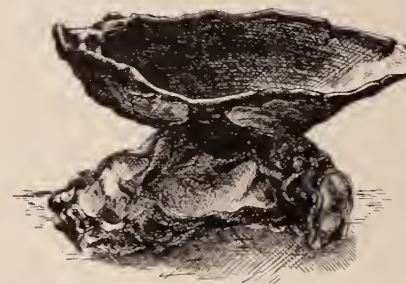

DESIGN—OYSTER SHELL—SALT.

MADE IN LARGER SIZES FOR ASH TRAYS, &c.

Design Patented.

THE Trade are cordially invited, when visiting New York, to call at our Office, No. 30 Union Square, and inspect our line of samples for the Spring Season.

Our MR. FRANK MAUSER will soon call on you with a full line.



At the annual meeting of the New England Manufacturing Jewelers Board of Trade the following board of directors were elected: Dutee Wilcox, of D. Wilcox & Co.; William R. Dutemple, of William R. Dutemple & Co.; George L. Vose, of George L. Vose & Co.; Hoffman S. Dorchester, of Brown & Dorchester; Hiram Howard, of Howard & Son; Nathan B. Barton, of Ostby & Barton; B. A. Ballou, of B. A. Ballou & Co.; Fred I. Marcy, of Fred I. Marcy & Co.; G. E. Luther, of G. E. Luther & Co.; William G. Hopkins, of George B. Champlin, of S. B. Champlin & Son (all of Providence); N. L. Ripley, of Ripley, Howland Manufacturing Co., of Boston; Everett S. Horton, of Horton, Angell & Co., Attleboro; S. E. Fisher, of S. E. Fisher & Co., North Attleboro; J. J. Horton, of Short, Nemej & Co., Attleboro; E. J. Franklin, of E. J. Franklin & Co., North Attleboro; D. H. Cory, of Plainville Stock Co., Plainville; J. M. Fisher, of J. M. Fisher & Co., Attleboro; J. L. Sweet, of R. F. Simmons & Co., Attleboro Falls; and J. D. Lincoln, of L. Bacon & Co., Plainville. At a subsequent meeting of the directors the following officers were elected for the ensuing year:—President, Dutee Wilcox; Vice-Presidents, William R. Dutemple and Everett S. Horton; Treasurer, Hoffman S. Dorchester; Secretary, Marcus W. Morton; Finance Committee, William G. Hopkins, George E. Luther and George B. Champlin.

W. E. White & Co., 53 Page street, are making a specialty of gold bead necklaces which they produce by a new process, from the pure metal. The beads thus obtained are much more solid and strong than those made after the old method, and will not bend. They have the exclusive right to these beads in gold. Their "Pomham" collar button, which they claim to be the lightest in the market, and at the same time stiff and strong, is increasing in popularity as its merits are tested.

"F. and B." as a trade-mark has become as widely known in the plated jewelry line as any mark in the trade. In the course of their business existence of nearly twenty years, Foster & Bailey have by their adherence to quality in plate and an unflinching originality in design given it a standing second to none. Their goods are everywhere accepted as the standard of plated manufacture. The past year they have been making unusual exertions in the way of novel ideas, enlarging their line by the addition of many striking and original designs. Among these may be mentioned the "Joe Jefferson" and "Stanley" souvenir bracelets in sterling silver, and more recently, the "Washington" bracelet, somewhat similar in conception to the above. The latter is a medallion bracelet reproducing the coat of arms of the Washington family the original American flag, a likeness of the first president, and other interesting data connected with his life. It is certain to have a large sale. Another novelty of theirs that is attracting attention is a solderless locket which is more solid in structure and neat in appearance than the soldered style of locket,

HEADQUARTERS FOR
14-K. BEAD NECKLACES,
GOLD JEWELRY,
 — AND —
Krementz One-Piece Collar Buttons.
KREMENTZ & Co.,
 MANUFACTURERS,
182 & 184 Broadway, NEW YORK.



THE OLD MAJ.



HIS GRIP.

BROOKS & PIKE,
 BOSTON, MASS.

THE FIRST AND SECOND EDITIONS OF

The Sun.



Interchangeable Initial Ring



HAVE NOW BEEN ISSUED.

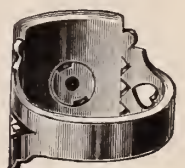

Send in Your Subscriptions at once.

Simple in Construction; Easily Adjustable;
 *Satisfactory in Results.*

Special Designs will be furnished to Jobbers for their exclusive use.

JULIUS WODISKA & CO.

49 Maiden Lane, New York.

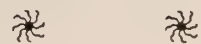

Chicago Office: H. L. Joseph, 155 State St.

TO THE JOBBING TRADE ONLY.

St. Louis.

January 30.

ALL hands have apparently made money this winter. Mr. Merrick, of Merrick, Walsh & Phelps, and Goodman King, of the Mermod-Jaccard Jewelry Co, both say that this year has been an unusually profitable one to the trade. The December sales were checked considerably by the monetary disturbances which began in South America, reached over to England and seriously embarrassed the great banking house of Baring Brothers. The sympathetic effect of the English and New York panics reached St. Louis and the retail jeweler felt the effect of the monetary stringency.

Mr. Merrick said yesterday. "I think that we are getting some of the regular holiday business now. I never experienced a better January trade, and I account for it by saying that the people who were afraid to make purchases in December have recovered confidence.

There is a new fad which is making itself felt here in the collection of odd designs in silver spoons, and everybody who can afford to do so is buying them.

The Mermod-Jaccard Jewelry Co. is engaged in a clearing sale of art goods. They have marked down their holiday prices, and Goodman King is busy devising new advertising schemes. This house claims to have the largest floor space, in a single room, in the world devoted to the sale of jewelry, bric-a-brac, silver goods and decorative art goods. A large business in Mexican opals appears to be the leading local fad, and this house is paying especial attention to it.

It's worth something to hear Mr. Merrick, of Merrick, Walsh & Phelps, tell about his recent trip to Mexico. He was gone only a few weeks but he saw a whole lot of things which were new to his eyes, and like a sensible man and an appreciative traveler he enjoyed everything new. He tells one story about a waiter in an eating house on the Mexican National Railroad who bore a huge platter along the table behind the guests. The platter contained a mixture which seemed to be a combination of scrambled eggs and omelette. The waiter had a long iron spoon and did not think it worth while to ask the guests whether they wished any of the

stuff or not, but reached over their shoulders with the spoon and flopped a "gob" of the eggy dish upon every plate.

Tom Davis, of the Middletown Plate Co., and Bob Wilcox, of Roger, Smith & Co, were among the traveling men in town this week.

John Bolland, the oldest jeweler in St. Louis, died on December 31st, after forty-eight years residence here, and after forty-two years active business in the jewelry trade on his own account. He left a good estate, which he disposed of by will. His business will probably be continued.

St. Louis is said to have led the country in the monogram fad on stationery, jewelry, and silver plate.

F. A. Durgin, who was for many years in business here on his own account, is now employed permanently in the silver ware department with the Mermod & Jaccard Jewelry Co.

Gus Kurtzeborn, president of the L. Bauman Jewelry Co., is back from New York.



ROGERS & BRO. A-1.

HOLLOW WARE.



OLDEST BRAND AND HIGHEST GRADE OF
ELECTRO SILVER PLATE.
ROGERS & BROTHER, Manufacturers,

16 Cortlandt Street, New York.

Waterbury, Conn.

Photograph Albums and Price Lists upon application, with Business Cards.

WATERBURY CLOCK CO., CLOCK MANUFACTURERS.

SALESROOMS:

10 Cortlandt St., New York,

GEO. M. VAN DEVENTER, AGENT.

SALESROOMS:

114 & 116 Wabash Avenue,
CHICAGO,

H. S. PECK, AGENT.

SALESROOMS:

528 & 530 Market Street,
SAN FRANCISCO.

A. I. HALL & SON, AGENTS.

FACTORIES:

Waterbury, Conn.

123 Stockwell Street, Glasgow,

T. R. DENNISON, AGENT.



TRADE MARK.
STERLING ⁹² —
— 1000

FRANK W. SMITH



GARDNER, MASS.

Their Seventh Annual.

Transactions at the Recent Meeting of the Jobber's Association

Names of Jobbers Who Were Present—Pleasant Words From President Hahn * Committees Appointed and Resolutions Passed.

THE Seventh Annual Meeting of the National Association of Jobbers in American watches was called to order at half past ten o'clock on Tuesday morning in the banquet hall of the Café Savarin. The following representative houses responded to the roll-call:

Boston: Kettell & Blake, 376 Washington street; Morrill Bros. & Co., 403 Washington street; A. Paul & Co., 375 Washington street; D. C. Percival & Co., 392 Washington street; Smith & Patterson, 44 Summer street; E. A. Whitney, 403 Washington street. White River Junction: Bogle Brothers. Hartford: Henry Kohn. New York: Aiken, Lambert & Co., 23 Maiden Lane; C. G. Alford, & Co., 200 Broadway; Arnstein Bros & Co., 37 Maiden Lane; Frank Bayerdoerfer, 41 Maiden Lane; C. K. Celby, 11 John street; Jos. Fahys & Co., 38 Maiden Lane; Max Freund & Co., 8 Maiden Lane; R. & L. Friedlander, 65 & 67 Nassau street; Henry Ginnel & Co., 31 Maiden Lane; E. A. Haldiman, 7 Maiden Lane; Keller & Untermeyer, 11 John street; Keller, Ettinger & Fink, 24 John street; Koch & Dreyfus, 22 John street; Krugler, Kimball & Co., 14 & 16 John street; S. Levison, 49 East Broadway; Lissauer & Sondheim, 12 Maiden Lane; Albert Lorsch & Co., 37 Maiden Lane; David Marx, 52 Maiden Lane; Henry May, 21 Maiden Lane; Metzger, Martin & Co., 7 Maiden Lane; S. F. Myers & Co., 50 Maiden Lane; Chas. D. Morgan, 176 Broadway; F. N. Nauman, 36 Maiden Lane; Geo. W. Pratt & Co., 14 John street; Roseman & Levy, 41 Maiden Lane; Adolphe Schwob, 4 Maiden Lane; J. T. Scott & Co., 4 Maiden Lane; Stern Bros. & Co., 30 Maiden Lane; Byron L. Strasburger & Co., 31 Maiden Lane; Edwin A. Thrall, 3 Maiden Lane; Trier Bros., 15 Maiden Lane; W. Hayden Wheeler, & Co., 2 Maiden Lane, N. H. White & Co., 12 Maiden Lane. Elmira: M. Freudenheim & Bro.; Freudenheim & Abramson. Binghamton: E. D. Vosbury & Co., Taylor & Wright. Rochester: Philip Present. Buffalo: Ansteth & Rensch; King & Eisler. Syracuse: A. Lesser & Son; L. Levy; A. Lewis. I. J. Liberman. Philadelphia: B. F. Conner & Co., 632 Chesnut street; Henry Euler, 716 Chesnut street; Hollinshed Bros, 806 Chesnut street; H. O. Aurlbut & Sons, 938 Market street; S. Kind & Co., 421 & 443 Market street; Wm. Morris, 706 Chesnut street; Philadelphia Optical & Watch Co. (Limited), 916 Chesnut street; M. Sickies & Sons, 618 Chesnut street; Simons Bros & Co., 618 Chesnut street. Lancaster, Pa.: Bowman & Musser. Scranton, Pa.: N. B. Levy & Bro. Pittsburgh, Pa.: G. B. Barrett & Co., 105 Fifth Avenue; Goddard, Hill & Co., 43 Fifth Avenue; Heere & Bros., 42 Fifth Avenue, Baltimore: M. Daniel; Hennegen, Bates & Co.; Cleveland, O.: The Bowler and Burdick Co.; Sigler Bros. Cincinnati: Hellebush, Clemens, 77 W. Fourth street; Schroder, D., & Co., 252 Race street; A. G. Schwab & Bro., 53 W. Fifth street; Strauss & Stern, 19 Arcade street. Zanesville, O.: John M. Bonnet. Chicago: Benjamin Allen & Co., 111 and 143 State street; H. F. Hahn & Co., 157 Franklin street; C. H. Knights & Co., 125 State street; Lapp & Flershem, 94 to 98 State street. M. A. Mead & Co., 104 State street; F. M. Sproehle & Co., 114 & Wabash Ave.; J. M. Weinberg, 96 State street; Minneapolis: Reed & Dibley; Omaha: Max Meyer & Bro.; St. Louis, Mo.: S. J. Rider, 708 and 710 Washington ave. Proxies were presented from the following: Joseph Goldberg, 67 Nassau street. Philadelphia: Pfafzer Bros. & Co., 815 and 821 Market street. Baltimore: W. S. Justin & Son; D. Oppenheimer & Bro. Chicago: B. F. Norris, A. Lister, & Co., 113 and 115 State st.; O. W. Wallis & Co., (agents), 107 State street. Minneapolis: Minneapolis Jewelry Mfg Co. Kansas City: M. Benjamin, San Francisco: Greenberg & Bier, 126 Kearney street; Alphonse Judas, Chronicle Building.

During the roll call the members busied themselves in exchanging friendly greetings, and a notable spirit of harmony and good feeling prevailed.

President Hahn then delivered his annual address which was received with great applause.

PRESIDENT HAHN'S ADDRESS.

Fellow Members of the National Association.

GENTLEMEN:

Another year has gone by, the sixth since our Association was formed, and we enjoy once more the pleasure of meeting here and taking counsel together how best to make permanent the good results we have achieved.

The spirit and purposes of our organization, and the way in which they have been carried out, have made the American watch business an easy one. The industry has grown to be one of the largest in the country. The general excellence of the American-made watch movements as reliable time-keepers is today an acknowledged fact by both dealers and users everywhere. The manufacturers of watch cases have kept full pace with those of watch movements in the betterment of their product, and have made valuable improvements.

The platform upon which the members of our organization stand is one of honor. It demands of them nothing more and nothing less. Have we kept faith each with the other? I regret that I have to report there have been a few instances where either need or greed has impelled some of our members to disregard the principles which should have governed their conduct. As I do not know the special causes which led members to violate our compact, I shall not attempt to pass a harsh judgment on them. It is not unlikely that they would be glad to undo what they have done. All men should bear in mind the fact that whatever avenue of life they tread, their work cannot be permanent unless it rests on the grand foundation of fixed principle. Whatever a man's business may be, his measure of success depends on how far he keeps his word, and lives up to his promises to his fellows. This, which is the commercial honor of the tradesman, is his capital. He who loses it imperils his opportunity for success, for he makes it unsafe for others to put him in any place of trust.

During the year the sub-committee has had some grave questions to consider. Association goods have been used as "leaders" and sold at cut rates by dealers not in fellowship with us. The advisability of forbidding the sale of such goods to any wholesale dealer not a member of our association has been urged by many. It is for you to say whether or not this committee shall have discretionary powers to pass rules in addition to those in force, but not in conflict with the constitution. The annulling of all rules relating to fines has also been strongly urged, and it has been suggested that a rule should be passed providing that the violation of contracts shall mean expulsion. I recommend that a committee be appointed to consider the propriety of granting such a power, and to report its conclusions at this session for your further consideration. I have sufficient faith in the honor of members to believe that past infractions of the rules will not be repeated, but I leave the question with you to decide.

It affords me pleasure to say that it is the general experience of all that the past year has been the best business one known to the jewelry trade. More goods have been sold than in any previous year, and our customers, the jewelers, have been equally as fortunate as we.

In view of the fact that our association is composed of merchants who are competitors in the fullest sense of the term, and who manage their business as they see fit, as a whole we have done fairly well in maintaining our agreements each with the other, and with the co-operating manufacturers. We feel that we have done our full duty towards them, and trust that our relations with them will continue to be of the same harmonious nature as those which existed for the year closed.

The Secretary and Treasurer reported the membership to be 185, being a net loss of 2 during the year, and a balance in the Treasury of \$1,962.44 with assets yet to be realized on of about an equal amount.

The question of new business was then brought up, and after several members had proposed changes in the rules, and some additional legislation, it was voted that the chair appoint a committee of 7 who should receive all the suggestions of the members, who should, after conferring with the manufacturers, report the results of their deliberations to the meeting for approval. The committee was composed of the following gentlemen:

Mr. L. W. Flershem, of Chicago, M. J. Lissauer, N. Y.; Clemens Hellebush, Cincinnati; D. C. Percival, Boston; S. Kind, Phila.; Otto Heeren, Pittsburgh; R. E. Busdick, Cleveland.

A communication was read from the manufacturers making suggestions to the meeting, and was referred to the committee, as was also a memorial from the Retail Jewelers' Association of St. Louis.

The meeting then adjourned to 2.30 P. M.

On reassembling, the election of officers was taken up and the president, vice-president and secretary and treasurer were re-elected by unanimous consent.

There were four nominations for the three members of the sub-committee, and a ballot was taken resulting in the election of Messrs. L. W. Flershem, Henry Ginnel, and David Keller, as the committee, with E. S. Smith, F. R. Simons and Leopold Stern as alternates.

The conference committee then presented their report, and it was voted to take it up in sections.

The first one was:

Resolved, That it is contrary to the spirit and rule of the Association for any member to supply any Association goods directly or indirectly either by sale or exchange, at any price or on any terms to any wholesale dealers in watches, jewelry, or other merchandise, who are not members of the Jobbers' Association, or to manufacturers of movements, cases, jewelry, etc., not in co-operation therewith, or to supply such goods to any one who it may reasonably be supposed will sell them to such parties.

Under this rule, the members are especially prohibited from furnishing Association goods, directly or indirectly, in payment for jewelry, gold cases, or other merchandise.

This section brought out considerable discussion, and, as there seemed to be a misunderstanding as to its meaning, it was finally voted to refer the matter to the Sub-Committee with power to formulate a rule on the question.

The second section was:

RESOLVED, That in future the Sub-Committee shall impose a fine of not less than one thousand dollars for violation of contract on the first offence, and that upon a second conviction of violation of contract the only penalty shall be expulsion from membership.

A motion to amend to \$2,000 having been lost, it was voted to adopt this section.

The third section was:

RESOLVED, That members of the Jobbers' Association who have withdrawn, or may withdraw, and who remain in business, shall be subject to the same rule in regard to readmission as is now in force regarding expelled members.

This section was also adopted.

The secretary was instructed to inform the St. Louis Retail Association that their memorial had been received and referred to a com-

mittee to make a rule covering the points they mention, as far as is practicable.

The watch case manufacturer's proposition to allow rebate in future upon all cases in stock at the time of reduction, instead of only upon those which had been purchased within six months, was received with approval and promptly accepted. After passing a vote of thanks to the officers and appointing Messrs. E. F. Smith, David Keller and H. H. Butts as the Auditing Committee for the ensuing year, the meeting adjourned *sine die*.

Pleasant!

CUMBERLAND, MD.

I would not think of doing without THE CIRCULAR.
L. C. ROERSLER

MIFFLINTOWN, PA.

I do not want to miss a single number, as I preserve every copy and have all THE CIRCULARS since I first subscribed.

J. W. WAGNER

SELMA, ALA.

Although I am not now in the retail business, there is so much good reading matter, both instructive and entertaining, in THE CIRCULAR that I would not like to be without it. I consider THE CIRCULAR one of the best trade papers, if not the best, issued.

JNO. PICKLES.

The Highest Grade

— OF —

Electro Silver

Plated Ware

Is Stamped with the



ROGERS TRADE-MARKS.

MANUFACTURED BY

The Wm. Rogers Manufacturing Co.,

P. O. DRAWER 30,

HARTFORD, - CONN.

WILLIAM B. DURGIN

Designer and Maker of Wares in

STERLING · SILVER

SPECIALTY OF

Plain and Fancy Flatware

CONCORD, N. H.

JOHN A. RILEY,

860 Broadway, New York,

MAKER OF

Hair Pins, Plain and Gemmed, Grecian Fillets,
BROOCHES HAT PINS
BRACELETS QUEEN CHAINS

SCARF PINS

SCARF HOLDERS.



HEARTS.

MOONSTONE,
TURQUOISE,
HEMATITE.

GARNET,
ROSAINE,
CORAL.

Mounted in

GOLD and SILVER

BONNET PINS AND BROOCHES.

Lawson & Van Winkle,

11 Maiden Lane,

NEW YORK.

ESTABLISHED 1837.

TAYLOR & BROTHER,

Old House READ, TAYLOR & CO.,

IMPORTERS OF

Diamonds and Pearls

AND

Manufacturers of Diamond Jewelry,

860 BROADWAY, NEW YORK.

Branch Office, 1 1/2 Maiden Lane.

21 HOLBORN VIADUCT,
LONDON.

206 KEARNY ST
SAN FRANCISCO.

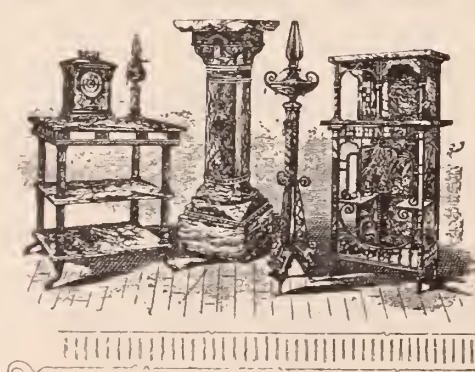

Schlumberger & Co.

MEXICAN ONYX AND BRONZE

Art Workers in

PEDESTALS, CABINETS, TABLES,
LAMPS, CLOCKS ETC.

47 W. 42nd Street.

ESTABLISHED 1849

WORKS: { 58 WEST 43D STREET
AND AT CARLSTADT N. J.,

NEW YORK.

Town Talk.

It will be remembered that about ten years ago coral jewelry in necklaces, bracelets, rings, earrings, brooches, etc., was very popular. About that time the Celluloid Novelty Co., then about a year old, was reorganized, and began to cater to the reigning fad by making jewelry of celluloid in imitation of coral. The success attending this undertaking proved to be the foundation of the company's success. A few weeks ago four hundred and fifty-five great gross of finger rings, a reminiscence of the old fashion, which had proved unsalable at any price, were accidentally sold to Robert Foulds, of Chambers street, New York, at 70 cents per gross. The latter disposed of the stock quite easily in small lots of dozens or half grosses to retail jewelers and fancy goods dealers at from 95 cents to \$1.00 per gross. A lot of necklaces of red celluloid, which during the fashion sold at \$15 per dozen, was disposed to E. Ridley & Sons at \$6 per gross. Such is the whirligig of fashion.

At one portion of that famous dinner on the evening of January 21, when the festivity was at its height, S. F. Myers was noticed busily occupied in looking after the interests of the reporters present. Some one remarked that he seemed to be working hard. "Well," replied Mr Myers, "when a thing must be done, and circumstances are such as to make others incapable of doing it, I believe in doing it myself." The fulfilment of the principle underlying this statement has produced many famous men.

We often hear the expression "the jewelers hotel," referring to the Astor House, "the clothing man's hotel" referring to the Grand Central, the "dry goods man's hotel," the Metropolitan, "the actor's hotel," the Morton, etc., these terms having been given birth to through an idea of the several hotels predominance of patrons. A jeweler visiting the city is usually sought for, if the place he is stopping at is not definitely known, at the Astor House. Yet the proportion of the total number of visiting jewelers staying at that hostelry is smaller than is generally thought. About 1,200 jewelers visited New York last year; some, mostly the jobbers, coming twice. Of this number about 15 per cent stopped at the Astor House. A goodly number, forsooth, but smaller than is generally supposed.

One of the best-known and popular club men in New York's sister city is Joseph B. Bowden, who is president of the Lincoln club, perhaps the most exclusive organization in the City of Churches. No social gathering in club life in that city seems to be complete without him, and his handsome and kindly presence is greeted with pleasure wherever he makes his entrance.

A comparatively new comer to the New York jewelry trade, and one who has already acquired considerable prominence among the opticians and optical dealers is Dr. F. Ogden Stout. He is engaged as optician for the

ESTABLISHED 50 YEARS.

RANDEL, BAREMORE & BILLINGS,

IMPORTERS OF

DIAMONDS,

AND OTHER PRECIOUS STONES.

FINE PEARLS A SPECIALTY.

MANUFACTURERS OF

DIAMOND JEWELRY,

IN THE LATEST DESIGNS.

Diamonds Recut in Modern Styles or Repaired on Premises.

58 Nassau Street,
29 Maiden Lane,
NEW YORK.

1 Tulp Straat,
AMSTERDAM.

1 St. Andrews St.,
Holborn Circus.
LONDON, E. C.

LARTER, ELCOX & CO.

FACTORY,
NEWARK, N. J.

OFFICE,
41 & 43 Maiden Lane, N. Y.

MANUFACTURERS OF THE

PATENT SPRING BACK STUD



Which has met with decided Approval and Ready Sale since its introduction to the trade.

MADE in four sizes, Polished and Roman Gold, also Moonstone and other Fancy Patterns. Mountings for Diamonds. White Onyx, plain, and with Diamond Center.

Selection Package of these Studs sent on Application.

ALSO MAKERS OF GENTLEMEN'S SEAL AND FANCY RINGS.

Ladies' and Children's Rings in great variety.

HENNEGEN, BATES & CO.

BALTIMORE, MD.,

Manufacturing Jewelers,

DIAMOND IMPORTERS

AND JOBBERS

IN ALL GRADES

AMERICAN WATCHES.

GOLD, SILVER AND NICKEL CASES.

Cor. Baltimore and Charles Streets.

W. E. W. & CO.

Manufacturing Jewelers,



54 PAGE ST., PROVIDENCE, R. I.

OUR FINE Line of Gold Goods this season includes Bead Necks in ten and fourteen carat, Scarf Pins, Drops, Jersey Pins, Dress Sets, Rings and Bracelets, Band Bracelets in Plate, and the celebrated *POMHAM* Collar Button. To these has been added a full line of White Stone Goods in Gold for the Spring Trade. It should be remembered that **OUR GOLD BEAD NECKS ARE THE LIGHTEST MADE.** Ask to see them.

W. E. WHITE & Co.

NEW YORK OFFICE, 26 MAIDEN LANE.

S. A. BALDWIN.



STERN BROTHERS,

"S"

A "NOVELTY" in Marquis Rings.

SEND FOR SAMPLE.

Manufacturers of Fine **DIAMOND MOUNTINGS,**

42 MAIDEN LANE, N. Y.

ATTENTION!

ALEX. WIEDERHOLD,
20 MAIDEN LANE, N. Y.,

Repairing Jeweler.

Jobbing sent to me by mail or express will be repaired and returned promptly. Prices Moderate and First-class Workmanship Guaranteed.

GILBERT T. WOGLOM

BLACK JEWELRY. **ONYX**
GOLD MOUNTED.

32 & 34 John St. New York City.

Spencer Optical Manufacturing Co., and attends to the literary work of that house. He is a tall young man, youthful and studious in appearance. He has contributed many articles on optical subjects to various technical journals. One of his literary productions is "Visual Defects and their Correction," published in book form by the Spencer Co., the first edition of 3,000 of which is nearly exhausted. He is a graduate of the College of Physicians and Surgeons of Baltimore.

On the south side of Chambers street between Centre street and Park Row is a plain yellow painted building which awakens fond memories in minds of several well-known figures in the trade. Years ago when 14th street was considered uptown, when some of the principal events in the city's history, and aye of the country, could not then have been even foreseen, that building was the Mechanic's Institute, one of the principal school-houses in the city; and in its precincts among other boys gambolled J. Eugene Roberts, Ulyse Courvoisier, elder brother of George Courvoisier, Louis Mathey, August Mathey and J. L. Mulford. The boys were firm friends there, and to their ripe manhood have remained so. At the present time there is a somewhat different gambling indulged in in that building, for it is the site of one of the most thriving horse race pool rooms in the city.

Recently at a railroad station near the city in the crowd of passengers that alighted to partake of the standing dyspeptic lunch were noticed two young men, one about six feet, the other about five feet in height. The smaller man by his easy manner, appeared as one who had no particular love of work, while the taller was spry and earnest. After indulging in the hard and forbidden viands, the smaller man said, "Oh, let me pay."

"Oh, no; let me pay," said the tall man.

"Oh, no."

"Oh, yes," and he paid.

"How much did it amount to?" asked the smaller of the larger.

"One dollar."

The short man looked up quizzically to the high man, and asked slowly.

"What have you been eating? Jewelry?"

The principle, "Do not let sentiment enter into business" is one which all men of affairs appreciate. The business side of the life of man is distinct. Starting out with the knowledge that a commercial transaction is mutually beneficial, for the man that sells gains in some material form, and the man that buys also gains in some material form, the merchant will not allow a petition which appeals to his heart to interfere with the general principle which is the foundation of success in business,—to gain in every transaction. Thus, it has come to be thought that business men are lacking in the finer instincts. That this feeling is not entirely correct the observer could have seen evidence at the banquet of the Jewelers' Board of Trade. The spontaneous enthusiasm aroused among the audience by the eloquent sentiments uttered by "Our Bob" regarding America, with his allusions to love—the love of beauty, art, woman, literature, and so on, would have made the heart of the lover of the human race bound with pleasure. For it was a beautiful sight, and the sneering cynic himself, had he been present, would have had the fortress of his aphorisms shaken on its foundations.

Communications.

School of Optics.

THE proposition published in the last number of THE CIRCULAR anent the formation of a school of optics, the members to consist of graduates of Dr. Bucklin's school, has been widely read and freely commented upon. Some who felt interested have written THE CIRCULAR on the subject and several of the letters received are published herewith:

PHILADELPHIA, January 6th, 1891.

To the Editor of the Jewelers' Circular:

I saw in your last issue the suggestion of Mr. Parker to form a Post Graduate Association of Ophthalmic Students. I think it would be a great benefit to us who are trying to elevate our business and make it a profession and a science rather than a mere money-making drudgery. I for one would be very glad to join such an association and to help form one. Yours,
CHAS. A LONGSTREES.

MONTREAL, P. Q., January 13th, 1891.

To the Editor of the Jewelers' Circular:

I am fully in touch with my fellow graduate, A. B. Parker, Esq., in the ideas expressed in his letter published in your January number. I believe the time is fully ripe for the formation of such an association. We could meet at some central point, elect a president and other officers, adopt by-laws and a constitution, submit papers on practical optics, enjoy discussions thereon, etc. The objects to be kept in view should be as follows: The elevation of our profession above that of the ordinary optician; emulation among its numbers to perfect themselves on sound and scientific principles; a general desire for optical knowledge and the interchange of practical experiences; elimination of all frauds and tricks having relation to our science. I shall have much pleasure in attending a meeting to perfect such an organization, and will be happy to give all the assistance I can to bring it to a successful issue. Yours respectfully,

SAM'L S. GRANT.
72 Beaver Hall.

OMAHA, Neb., Jan. 15, 1891.

To the Editor of the Jewelers' Circular.

I was pleased to read the communication from our friend Mr. A. B. Parker, Norristown, Pa., submitting to the readers of your esteemed review, the excellent suggestions regarding an organization in the interests of the professional opticians of our country. The desirable features of the project are clearly felt and understood by all who have undertaken the study and practice of the science. The complicated questions arising from the diverse forms of optical defects, occasioning a prudent judgment and action, to be rendered only from a perfect knowledge of the requirements, lead the thoughts toward the true merits of the prop-

DIAMONDS.

Wm. S. Hedges & Co.,
Importers of Diamonds,

And Manufacturers of DIAMOND JEWELRY.
No. 170 BROADWAY, } New York.
S. E. Cor. Maiden Lane, }
27 Holborn Viaduct, London.

OPPENHEIMER BROS. & VEITH,

Diamonds, Watches and Jewelry,

2 Tulp Straat,

AMSTERDAM.

35 Maiden Lane,

NEW YORK.

We beg to inform the trade that we are still in a position to fill orders for

✂ DUEBER HAMPDEN WATCHES ✂

Of all grades, from stock purchased previous to the closing of the factories at Canton.

R. & L. FRIEDLANDER,

Wholesale Jewelers,

— AND —

JOBBER IN AMERICAN WATCHES,

Tools, Materials and Optical Goods,

65 & 67 NASSAU STREET, N. Y.

Factory, 50 BOND STREET.

Send Business Card and we will mail you our Watch and Jewelry Catalogue, No. 12, and our Tool, Material and Optical Catalogue, No. 14.



Try our Monarch American Mainsprings, \$12.00 PER GROSS
\$1.00 PER DOZEN.

POSITIVELY NO GOODS SOLD AT RETAIL.

VACHERON & CONSTANTIN,
GENEVA, SWITZERLAND.

FINEST QUALITY OF WATCH MOVEMENTS, FITTING
ALL SIZES OF AMERICAN CASES.

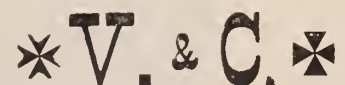

CHAS. LEO ABRY,

Agent for the United States and Canada.

41 and 43 Maiden Lane, - - - NEW YORK.



Chicago College of Horology,

SUCCESSORS TO

THE CHICAGO HOROLOGICAL INSTITUTE,

IS ACKNOWLEDGED by those who have investigated the subject to be a

FIRST-CLASS INSTITUTION,

Where those who desire to learn the art of WATCH MAKING and ENGRAVING can obtain the

BEST PRACTICAL INSTRUCTION.

New features are continually being added. It is the aim of those conducting the management of the College to make it the

BEST INSTITUTION of the kind IN THE COUNTRY.

C. R. HART, *General Superintendent,*

CHICAGO COLLEGE OF HOROLOGY,

CHICAGO, ILL.

WRITE FOR PROSPECTUS.



The Latest "PURITAN" Design.

RICH CUT GLASSWARE.



Headquarters in America for
ART GLASSWARES,
RICH CUT AND DECORATED.
Lamps, Vases and complete lines of everything for table use or household decoration.

MT. WASHINGTON GLASS CO.

NEW BEDFORD, MASS.

CATALOGUES FOR ♦ ♦ ♦ ♦

NEW YORK OFFICE, 46 MURRAY STREET. ♦ ♦ ♦

INTENDING PURCHASERS.

Established 1853.

CLOCKS



American and French CLOCKS and BRONZES

B. J. COOKE'S SONS,

137 N. 3d Street, Philadelphia.

Catalogues and Price Lists furnished to the Trade only, on application.

osition, and point clearly to the desirable features and benefits to be gained. The achievement of reaching the degree, of a thoroughly practical optician is to be acquired only by a perpetual struggle with principles and methods to be derived from optical literature, reduced to actual practice and generally associated with a constant harassing and mortifying series of inadvertable blunders, or by the more practicable and more desirable avenues offered by schools at present prominently before and within reach of the public. The Science of Optics is an interesting branch of professional science, its broad field offering a great source of agreeable study and reflection to those who desire to master its underlying and complex principles, technicalities, etc. The desire is stimulated for proficiency in the art, not simply in the practical adjustment of correction lenses to the defective eye, but it also reaches out to the various optical mechanical instruments, which search the heavens and the earth, opening the dark pages of nature and revealing the mysterious and wonderful.

Such an association of graduate opticians could, I believe, accomplish a vast amount of most valuable work affording information most beneficial and various. The mutual exchange of ideas and demonstrations, as Mr. Parker states, resulting from experienced peculiarities in patients, met with by the many associating members, would prove of the most interesting nature. The special talent he mentions as being secured as lecturers and conductors adds a still greater feature. All who have enjoyed the advantage of the practical instruction furnished by our esteemed friend, Dr. Bucklin, can heartily appreciate the desirability of listening again to him while he clearly dwells on the "objective and subjective." I think that it would be of great value to all to be furnished with an opportunity of listening to the prominent masters in the different parts of our country on this interesting subject. Such an opportunity can only be afforded by some such arrangement as suggested. I heartily commend the suggestion made by Mr. Parker, and I am pleased to add the broad and liberal plan as stated by Mr. Editor, and with him, I believe that to bring about the best results from such an association its formation should be made upon principles open to all competent parties belonging to the optical profession. The benefit of a universal voice, of modes, manner and methods, a corresponding feeling of interest in each other, socially, professionally and every other wise, would prove a pleasure and profit. I am pleased that this question has been placed before the opticians of the country, and I hope it may receive a favorable consideration, and that an active effort may result, ultimating in a permanent organization.

Yours respectfully,
MELVIN U. FOSTER.

SIoux FALLS, S. D., Jan 12th, 1891.

To the Editor of the Jewelers' Circular:

I notice in the January number of your excellent paper the suggestion of Mr. A. B. Parker regarding the formation of an Association of Post-Graduate Opticians and think the subject well worthy the consideration of all such who are studiously inclined.

I have wished a great many times since graduating, that I could attend a convention of oculists; but a convention of Opticians would be more to the point and, of course, deal with work more to my liking and necessities. I should hope, as you say editorially, that it might not be confined to any one school, but that it would be for the "mutual benefit and improvement of the profession" purely. A question that interests one this far away is the item of railroad fares; but I presume as in other cases special rates could be made. Can't we have a convention this year?

Yours Respectfully
GEO. P. TUTHILL,
June, 1889, Class,
Chicago Ophthalmic College.

PENN YAN, N. Y.

Enclosed we send you our subscription to the best paper on earth that is devoted to the jewelry and optical business and kindred trades. We do not wish to miss a single number.
E. H. HOPKINS.

MATHEY BROS., MATHEZ & CO.

16 MAIDEN LANE, N. Y. AND BRASSUS, SWITZERLAND,

MANUFACTURERS AND IMPORTERS OF

Plain and Non-Magnetic Movements.

Complicated Watches a Specialty.



REPEATERS.

CHRONOGRAPHS, MINUTE REPEATERS, AND SPLIT SECONDS,

IN ALL GRADES AND SIZES.

SOLE AGENTS FOR

H. L. Matile, C. H. Meylan and J. J. Badollet. Watches Demagnetized.



CHRONOGRAPHS.

SIG. HIRSCHBERG
IMPORTER OF
DIAMONDS
and
Manufacturer of
Fine Diamond
Jewelry.
78 Nassau St.
NEAR JOHN
NEW YORK.

A COMPLETE
LINE OF
Mounted
GOODS
Constantly
ON
HAND.

DIAMOND SETTINGS. GALLERIES. HOLLOW BALLS, ETC.

BLANCARD & CO.,

36 & 38 JOHN STREET,

SEND FOR OUR NEW YORK. CATALOGUE.

W. ROSENTALL,

Manufacturer of
SILK VEST CHAINS,
79 NASSAU STREET, NEW YORK.
Send for Selection Package.

CHALLEN
10
LABOR SAVING BOOKS
SPRUGE
NEW YORK.

Ruled, Printed and Indexed
Records, ARRANGED TO SAVE
TIME. Used by Advertisers,
Book and Newspaper Pub-
lishers, Engineers and others
to enter contracts quickly for
instant reference.

HOWARD CHALLEN,
10 Spruce St., N. Y.

FILIGREE JEWELRY

IS MADE OF GOLD OR SILVER IN

Lace Pins, Hair, Hat, Scarf and Jersey Pins, Bracelets, &c.

Also in Wedding Jewelry, Bridal Diadems, Myrtle Wreaths, etc., by

P. HARTMANN,

36 Maiden Lane, NEW YORK.

FOR THE

Best of **INKSTANDS** for Use or Selling,

APPLY FOR TERMS TO ABOVE.



THE WATCH CASE

SANITARIUM,

Nos. 4 & 6 Liberty Place, NEW YORK.

HENRY GOLL & CO.,

PROPRIETORS.

Favorably and widely known as the place PAR
EXCELLENCE for the substantial making and
artistic repairing of all kinds and conditions of
Watch Cases.

TO THE TRADE.
FINE WATCH REPAIRING

BY
JOHN C. SIMMONDS,

18 JOHN STREET, NEW YORK.

New pieces, such as Chronometer Locking Springs, Balance
Staffs, &c., made in the best styles. Watches sprung and
adjusted to temperature and positions.



The

Remington

has set the copy for writing
machines for 15 years.

It is to-day the

Standard

and expects in the future,
as it has in the past,
to lead all others
in adding improvements
to what will always be
the true model of a

Typewriter.

Wyckoff, Seamans & Benedict,
327 Broadway, New York.



Easy Lessons for Opticians.

BY C. A. BUCKLIN, A. M., M. D.

The first requirement for a clear conception of the conditions to be satisfied in persons suffering from weak, defective or annoying vision, is a clear and thorough understanding of the conditions which are present in persons who have perfect eyes and who do not suffer from weak or annoying visions.

With a thorough and complete understanding of the requirements for comfortable near and distant vision, it becomes an easy task to grasp and comprehend the many complicated conditions which cause the binocular visual act to become a source of annoyance and distress.

The following conditions are necessary: The two eye-balls should be of proper length, which is about nine-tenths of an inch. The cornea of which should be as nearly spherical as possible; by this it is meant they should not be oval. The accommodation should be perfect. In each eye, at any point where it may become desirable to direct both eyes, the various muscles which direct and control the relative positions of the visual lines should have the usual degree of strength and endurance, and possess the required harmony of action to direct the visual lines without fatigue at any point upon which it is desired to focus both eyes.

The various media through which light must pass along the visual axes of the two eyes must be clear of any unusual obscurities. The cornea and retina must not be the seat of any inflammatory process and the optic nerves must also be free from any of the diseases so frequently found to exist. The brain must also be in a proper condition for appreciating any impression conveyed to it through the optic nerve. There must be no decided irritation of the conjunctiva such as may result from foreign bodies in the eye or slight catarrhal inflammation. The nerves of the eye must be entirely free from any neuralgic symptoms. Every person who comes to an optician asking for the assistance which he hopes glasses may give him, has a failure in some one of the conditions which have been mentioned. It becomes the duty of the optician to tabulate in his mind all the possible conditions which may induce a person to seek glasses. Having these conditions thoroughly in his mind he is enabled by a rapid method of exclusion to decide which of the requirements for comfortable binocular vision is absent in an individual seeking aid from glasses.

The following is a list of the possible conditions which may exist in any presented case. Any error of refraction, hyperopia, myopia or astigmatism; any error of accommodation, as presbiopia, paresis, paralysis, or spasm of the accommodation; any defect in the ocular muscles, which makes it fat-

tiguing, difficult or impossible to maintain the fixation of both eyes on required objects at a required distance for a required time; any obscurity of vision which prevents the perfect passage of light to the retina; any inflammation of the choroid or retina which prevents the visual impression from being properly perceived. Any disease of the optic nerve which prevents the proper conduction of the visual impression to the brain; any disease which prevents the proper recognition of a visual impression perfectly conducted to it; any neuralgic trouble about the eye or any catarrhal trouble of the conjunctiva.

It now becomes the duty of the optician to decide by experimental test which of these causes occasion the annoying or defective vision.

The first step in the process of exclusion is a few routine questions. The first question to determine is the age. Persons under forty-five are not annoyed by presbiopia alone. The second question is regarding the nature of individual's vocation. A complaint from a farmer who does no literary work usually indicates a much more serious trouble with the eye than a similar complaint from an engraver or a skilled artisan, or from a student. The third question is what can the individual see at twenty feet on graded letters which represent the average standard of acuteness of vision. If the acuteness is equal to the average acuteness of vision, then we have excluded myopia, astigmatism, all obscurities of vision and all diseases of the brain, optic nerve and retina. The individual being under forty-five we have excluded presbiopia. Such individuals will complain of weak or annoying vision at the working distance, which can only be due, according to our method of exclusion, to hyperopia or some defect of the ocular muscles. The use of convex glasses before the eye will immediately determine in most cases the existence or non-existence of hyperopia. The strongest convex glass through which acute distant vision can be maintained represents the entire amount of manifest hyperopia which is present. If we find it impossible to demonstrate the existence of hyperopia, then the annoying vision at the working distance is due to a defective ocular muscle. Normal ocular muscles will usually see a candle flame double at twenty feet if a prism of two degrees base up or base down is placed before one eye. If a prism of more than three degrees can be placed before one eye, base up or down, without producing double vision in the vertical direction, there is a defect in the vertical muscles. The internal muscles should overcome a prism base out of from twelve to twenty-four degrees without producing double vision. If these muscles fail to overcome more than eight or ten degrees without seeing double, weakness of the internal muscles exists. The average external muscles can just overcome eight degrees of prism, base in, without seeing double. The power of the internal muscles may not be sufficient to overcome more than two degrees of vision. Persons having such weak external muscles usually suffer but little inconvenience at the reading distance. They become greatly fatigued in their at-

tempts to keep the visual axes parallel as they must do in viewing objects at a distance of twenty feet or more. They experience special fatigue in viewing mountain scenery.

The method of exclusion is rapidly completed in those cases where the distant vision is normal. It becomes much more complicated, however, and the possibilities of numerous troubles become possible when the acuteness of distant vision is much below the average standard. Still, we are obliged to return to the method of exclusion as being the only means which offer us a solution of the problem under consideration. The person being under forty we exclude presbiopia. We are then obliged to draw such deductions as we can from his experiences during the visual act at the working distance. If he sees with perfect comfort at the working distance, and does not experience fatigue or headache during the use of the eyes at the working distance, we may exclude with moderate certainty every one of the possible conditions excepting myopia. Visual obscurities, diseases of the optic nerve or retina, muscular defects, irritations of the conjunctiva, neuralgias, hyperopia and astigmatism, all have a tendency to make prolonged use of the eyes at the working distance annoying.

Experimental trials with the test lenses will usually demonstrate the correctness of our previous conclusion by demonstrating the fact that concave lenses improve distant vision. This establishes the fact that simple myopia is present.

The method of exclusion becomes still more difficult when we find not only the distant vision defective, but the near vision also defective. In this case, any of the possible conditions mentioned may exist. Still, there is no other means of determining the nature of the trouble except the simple method of exclusion, which in time must become as familiar to the optician as the multiplication table is to the mathematician.

(To be continued.)

Dr. C. A. Bucklin:

I have a case now which to me is the most peculiar I have ever met, and I think contrary to all the rules of Optics.

Young Lady, Aet. 23.

R. V. = $\frac{20}{40}$ W-100 D Cyle ax 1.65 = $\frac{20}{30}$
L. V. = $\frac{20}{40}$ W-100 D Cyle ax 15 = $\frac{20}{30}$

This glass, however, does not answer at all for reading, as the greatest distance she can see to read distinctly is about 6 inches, but with -1.12 D sphere in combination with above cylinders, she can see to read No. 1 distinctly at 12 or 14 inches, and she says they are perfectly comfortable. But this last combination destroys altogether her distant vision. It is a mystery to me why, at her age, the first correction does not answer for reading, and why it is necessary to fit a lens to throw it off to the necessary reading distance; where there is no myopia; for certainly there can be no myopia if a - sphere, blurs distant vision. Can you give me any explanation as to what state the eye must be in to make the different lenses necessary? If you can you will greatly oblige. I attributed it to a habit of hers more than anything else.

Yours truly,
D. E. SHOUP.

Providing + cylinders of same No. at right angles to - cylinders will not answer. No. 5 is correct in all his conclusions. The - spheres are accepted purely through the freak of a nervous, sensitive female. There is no reason for them and they are not required. Even if spasm of the accommodation exists, which I doubt, the girl is better off without the - spheres.

SOMETHING NEW



EVERY WEEK OF THE YEAR.

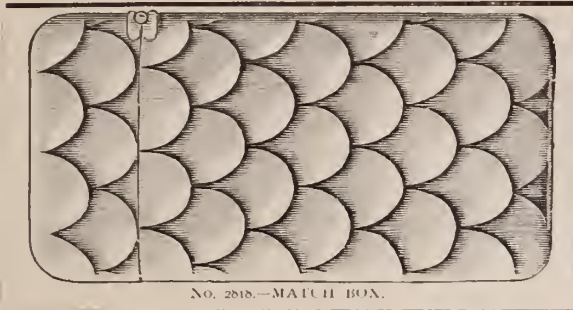

No. 2818.—MATCH BOX.

- Ash Trays,
- Baby Combs,
- Back Combs,
- Bag Holders,
- Belts,
- Belt Buckles,
- Belt Slides,
- Bonnet Pins,
- Book Marks,
- Boys' Chains,
- Bracelets,
- Brooch Pins,
- Button Hooks,
- Card Cases,
- Chatelaine Hooks,
- Cheese Knobs,
- Cigar Cases,
- Cigarette Cases,
- Cigarette Holders,
- Cloak Clasps,
- Crowns,
- Court Plaster Cases,
- Cuff Holders,
- Decanter Labels,
- Earrings,
- Envelope Openers,
- Fan Fobs,
- Flasks,
- Garters,
- Glove Hooks,
- Hairpins,
- Hairpin Cases,
- Hairpin Trays,
- Hair Ornaments,
- Hat Pins,
- Head Bands,
- Hose Supports,
- Jersey Pins,
- Jewel Cases,
- Key Chains,
- Key Rings,
- Lace Pins,
- Manicure Goods,
- Match Boxes,
- Memoranda,
- Mirrors,
- Necklaces,
- Odor Balls,
- Padlocks,
- Paper Knives,
- Pen Racks,
- Pen Wipers,
- Picture Frames,
- Pin Cushions,
- Pipes,
- Pocket Combs,
- Pocket Knives,
- Purses,
- Queen Chains,
- Safety Pins,
- Scarf Pins,
- Scarf Rings,
- Seals,
- Shoe Horns,
- Side Combs,
- Slipper Buckles,
- Smoking Sets,
- Soap Boxes,
- Stamp Boxes,
- Suspender Buckles,
- Tablets,
- Tape Measures,
- Tobacco Boxes,
- Tooth Brush Cases,
- Towel Rings,
- Victoria Chains,
- Vinagrettes,
- Whist Counters,
- Whistles, &c., &c.



No. 2805. SCARF PIN.

Finest Gold Plate and Silver Plate, BARSTOW & WILLIAMS,

NEW YORK OFFICE: 198 BROADWAY.
(For Samples Only.)

14 FOUNTAIN STREET,
PROVIDENCE, R. I.

T AS CHEAP, **T**
W AS EASY, **W**
I AS DURABLE, **I**
C AS HANDSOME, **C**
E AS PRACTICAL, **E**

—IS—

WORCESTER & McDONALD'S

NEW PROCESS

OF

ELECTRO-PLATING

BY

ANODES.

You buy the ANODES and we do the rest.

SEND FOR CIRCULAR.

WORCESTER & McDONALD,

120 Friendship Street,

PROVIDENCE, - - R. I.

RIPPART & Co.
 MANUFACTURERS
 OF
Fine Jewelry.
 Cor. Marshall & Halsey Sts.
 Newark, N. J.
 LELONG BUILDING
 NOVELTIES AND DIAMOND MOUNTINGS

KENDRICK & DAVIS,

LEBANON, N. H.

MANUFACTURERS OF THE



Standard Dust Proof Watch Key.

After this date all Keys of this Style will have number stamped on each Key.

FOR SALE BY THE TRADE.

WELDED CHROME STEEL AND IRON

5 PLY.

FOR BUILDING

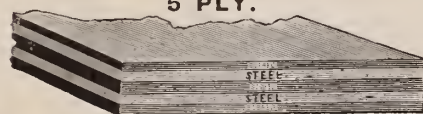

Jewelers' Safes, Vaults, Etc.

Positively Burglar Proof, cannot be Cut, Sawed or Drilled.

OUR TRADE MARK is stamped on all our goods and we caution purchasers to avoid imitations. We are the sole manufacturers of genuine Chrome Steel in the United States.

CHROME STEEL WORKS,

Kent Avenue, Keap and Hooper Sts., Brooklyn, N. Y.

S. H. KOHN, PRES. C. P. HAUGHIAN, VICE-PRES. J. G. DUNSCOMB, SEC.



HILDRETH MFG. CO.,



PLAIN SOLID GOLD RINGS,



6 DWT



7 DWT

51-53 MAIDEN LANE, NEW YORK.

SEND FOR PRICE LIST.

PLEASE READ THIS. *



IT IS JUST WHAT YOU ARE LOOKING FOR.

WILLIAM F. NYE:

DEAR SIR:—Some years ago I had a little experience with Watch Oils that I shall never forget. I had just located in this north-western country, and as you may know, the thermometer here in the winter goes down to 40° and 50°, and I have seen it down as low as 64° below zero. I had never paid any particular attention to Watch Oil, but used what my jobber sold me for the best. For some time I was greatly bothered with watches coming back to me apparently all right, but the customers said they would stop at night or at other times when subjected to extreme cold. After experimenting I found that the oil would congeal or become thick and stiff, and actually stop the watch. The question then arose, was there any oil that would stand this cold.

I ordered of my jobbers some six different brands of oil (your oil was one of them), and tested each oil by taking a movement in perfect condition, carefully cleaned and oiled with one brand, and placed it in a movement holder with glass back and front, and placed it out of doors when the thermometer was 50° below zero. After experimenting with one oil I would again carefully clean the movement and oil up with another brand of oil, and so on with all the different brands of oil I had, experimenting with the same movement in the same manner for each oil. The result was, with three of the oils the movement would stop inside of one minute. One would run one minute, and one nearly two minutes, and with only one oil would the movement continue to run without stopping. That one oil was yours, and it is needless to say that I have never attempted to use anything else since.

DETROIT, MINNESOTA, Nov. 19TH, 1890.

Respectfully yours, D. L. BROWN.

The above is but one of the many letters we receive from customers in northern latitudes, where the thermometer sinks to hard-pan and announces Old Boreas holding high carnival in Arctic wastes. It was by reason of this pressing demand for an oil that would not congeal or become "thick and stiff" under his sway that led us to utilize his forces by establishing a plant in a Canadian climate for the preparation of the oil, and the result has proved most gratifying, "the one thing needful"—the "Ne Plus Ultra" of all oils heretofore offered for use on watches and clocks in either cold or hot countries, and we will only add that we have the assurance of the management of all the leading watch and clock factories, where most critical tests are made with the oil, that it affords them a satisfaction beyond any oil ever before offered in the adjustment and accurate rating of their present elaborate and costly timers.

ASK YOUR JOBBER FOR WILLIAM F. NYE'S OIL, AND TAKE NO OTHER IF YOU PREFER THE

Most Skillfully Refined Watch and Clock Oil in the World.

William F. Nye

NEW BEDFORD, MASS.

A. J. LOGAN

Manufacturer of HAIR SPRINGS and HAIR SPRING WIRE, Bracelet Springs and Small Springs of every description; also Watchmakers' Tools.

21 CRESCENT ST.,

WALTHAM, MASS.



PIN VISE.—Price, 75 Cents.



BOSS CASE SPRING TOOL. Price, 50 Cents.



NON-MAGNETIC TWEEZERS.—Price, 10 Cents.

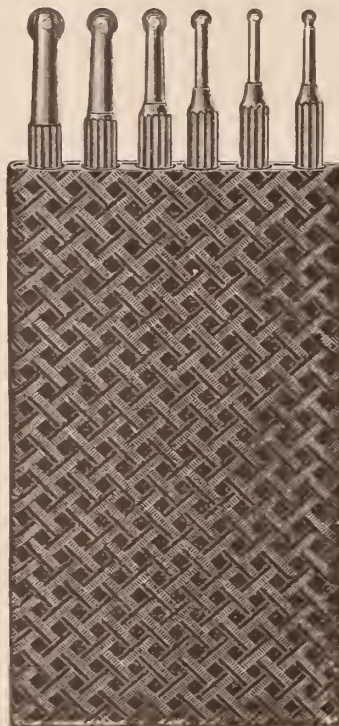

COUNTERSINKS AND BURNISHERS. Price, \$1.40.



GEM SCREW DRIVER. Five Sizes, \$1.25 per Set. Colored Heads—designating size of blade.



JAW AND DEPTH GAUGE. Patented Aug. 21, 1883. .001 of a centimeter or .001 of an inch, \$14.00. .01 of a centimeter or .01 of an inch, \$8.00.



UNIVERSAL BEAT BLOCK. For English, Swiss or American Watches. Price, 75 Cents.

Single Hair Springs vibrated to balance, 25c.; VIBRATORS made to order at \$5.00 each.

Vibrated and Colletted, 35c.; put in the Watch and brought to time, 75c.; Sets of Breguet Tweezers (4 in set) at \$5.00 per set.

Watches demagnetized, 50c. SEND FOR ILLUSTRATED CATALOGUE.

Defects Which Occur in the Cylinder Escapement.

PRIZE ESSAY BY ERNEST BERGMANN.

OF all the escapements hitherto used in watches, perhaps the cylinder escapement is the most universally employed. This is applied principally to cheaper watches, detached lever and chronometer escapement being with advantage used for fine movements.

Since the invention of the cylinder escapement by Graham in 1720, the construction of verge escapements has gradually been desisted from; on the one hand, partly for the reason that the cylinder escapement is a frictional one in which the loss of power generated in the recoil escapement by the recoil of the escape wheel, is completely avoided, and on the other because the cylinder escapement permits a construction of the train, dispensing with the defective contrate-wheel depthing.

Before I commence the enumeration of the peculiar defects of the cylinder escapement, I will premise that the following defects can be found in all the other watch escapements. The repairer is often called on to remedy a pinching of the pivots or a scraping of the balance. When correcting the former he should never omit to round off the pivots, as burr will readily arise in polishing. In the same manner pay special attention to the balance spring, jewel hole, and cap jewels. The balance spring is often treated in a very slovenly manner. Its method of fastening leaves much to be desired. The reason of the pin being loose is often the reason that a watch can be turned only with difficulty. The jewel-holes must be firmly fixed in their setting. A jewel-hole stands obliquely, occasionally, whereby a pinching of the pivot can be occasioned. Force the jewel out with a pegwood and by setting it straight the pinching will disappear. The cap jewels must be polished well on their face and must not move; it is therefore better to use settings. In adjustments it is occasionally found that the balance pivots do not touch the cap jewels. In this case the pivot must be made longer by turning. Since many watchmakers shun this job, however, the error may be corrected in another manner: viz., by removing the brass between jewel-hole and cap-jewel with the chamfer. But this procedure must in no manner jeopardize the firmness of the jewel-hole. In consequence of this the old cap-jewel becomes too small and must be replaced by a larger one.

We now come to the cylinder escapement. The defect most frequently occurring, perhaps, is that the escape wheel cannot pass freely through the passage of the cylinder, so that the wheel rim either touches the lower plug or the exit lip of the cylinder. This is remedied only by raising or lowering the cylinder, according to requirement. On account of the workmanlike appearance of the bridge, burr should never be raised on it nor anything laid underneath. Drill two pins in the corresponding bridge and file them away until the cylinder stands at the correct height.

New watches have occasionally a scraping motion. If a defect can nowhere be found the scraping will be occasioned by burr on the lower side of the escape wheel as it comes in contact with the lower plug. It is self evident that the escape wheel must be ground with an oilstone. Another also not unfrequently occurring error is, that the cylinder and escape wheel do not precisely fit to each other. In consequence of this, the wheel-tooth pinches either in the cylinder or on its exterior. This evil is readily generated in the replacement of one of the two parts. For this reason wheel and cylinder should be closely examined in the depthing tool to see whether the drop is equal on both lips of the cylinder. In order to have the escapement truly correct, the faulty part should in this case be replaced by a well-fitting one. Since this cannot always be done in repairing, on account of the price, the repairer must make use of the remedy of grinding off the wheel tooth. Views on this point differ. I, for my part, grind the teeth always on the points and round them off a little at the same time. By shortening the tooth at the stalk the wheel loses the correct lifting and a new error is created.

A very simple evil is the over-vibration of the cylinder. This is caused by the banking pin of the balance passing by its banking pin. The latter is simply bent a little more toward the cylinder; or if the watch is constructed in such a manner that the balance pin banks at the fourth-wheel pinion staff, a longer pin will remedy the error. It happens more rarely, however, that the balance banking pin remains hanging. It will be noticed in many cylinder watches, especially new ones, that they do not time easily, although the balance spring is in order. The watch generally accelerates in this case when it is fully wound, and the cause of it is that the cylinder banks. This defect may be due to different causes; either that the banking pin does not stand at its correct place, or that the mainspring is too strong. By replacing the latter with a weaker one, the error will be corrected and a satisfactory rate produced.

I will mention another error which will in most cases not directly produce the standing of the watch, but which will, at any rate, cause a lame vibration of the cylinder. I refer to a worn cylinder. If there is the space at disposal this is corrected by raising or lowering. If this cannot be done, however, correct the lifting faces by grinding with an iron file and oil stone powder until the lips have become smooth again. But if the cylinder is worn all around, it must unconditionally be replaced by a new one. When the faults of the cylinder watch have been corrected in the above described manner, and if, besides this, all the other parts are in good order and condition, it will render better service than many a cheap anchor watch.

The honor of having been the inventor of the cylinder escapement is by some authorities credited to Tompson, about 1700. This escapement is also occasionally called by English horological writers, "horizontal" escapement. The teeth of the verge's escapement (at that time the only one in common use) lie in a vertical place in the plane of the watch, and it was therefore also called the "vertical escapement." The term "horizontal" fairly distinguished the cylinder escapement when it was introduced, but since all the escapements in general use at present answer to their titles, "cylinder escapement" appears to be the more fitting term.—Ed.

MOORE & HORTON,

MANUFACTURERS OF

SOLID GOLD JEWELRY,

No. 11 Maiden Lane, New York.

Fine Imitation Diamond Goods a Specialty
Selection Packages sent on Application.

N. SCHWARZ,

MANUFACTURER OF

VELVET AND LEATHER CASES,

866 Broadway, New York.

A. J. GROENMAN & CO.,

DIAMOND CUTTERS,

80 Nassau Street,

NEW YORK.

SMALL MELEE A SPECIALTY.

J. SCHAWEL & CO.,

GOLD AND SILVER

Refiners, Assayers and Sweep Smelters.

Importers and Melters of Platinum.

GOLD AND SILVER BULLION BOUGHT AND SOLD.

29 JOHN STREET,

NEW YORK.

ESTABLISHED 1865.

THE WALTHAM SCHOOL OF HOROLOGY,

D. D. PALMER, Teacher and Proprietor.

Best Advantages in the Country for Horological Instruction.

All branches under the personal supervision of D. D. PALMER, for a number of years in charge of the Adjusting Department of the Waltham Watch Co. POSITIONS GUARANTEED TO APT PUPILS. For terms and other particulars, address

D. D. PALMER,

WALTHAM,

MASS.

Specialty of Difficult Repair Jobs.

A. RICKERT.

C.A. STIEHLE.

RICKERT & STIEHLE,

MANUFACTURERS OF

GOLD CHAINS,

SWIVELS AND SPRING RINGS.

Chain Repairing a Specialty.

13 & 15 Franklin Street.

NEWARK, N. J.

GENTLEMEN:—I think the trade this Spring will be better than last, and, although I can turn out double the work I did then, you had better be on hand with your orders, for I expect that my sales will be very large—equal to last Fall, if not double. You see the field is constantly widening and the demand is increasing, and why? Did you ever stop to think that there are 65,000,000 people in the United States, and the per cent. of this number that use glasses is one-fifth, or 20%, making 13,000,000 people wearing eye-glasses, and if you count the myriads in Europe and South America, why it is simply immense, and it needs cultivation. Why! Gentlemen, we ought to be able to double our business every year for the next ten years.

Yours respectfully,
Springfield, Mass. S. F. MERRITT.

A Complete History of Watch and Clock Making in America.*

BY CHAS. S. CROSSMAN.

Number Fifty-one.

Continued from page 65, January, 1891,

AMERICAN CLOCKMAKING AS A DISTINCTIVE INDUSTRY.—ITS EARLY PIONEERS.

WE have now come to an important part of the history of horology in America, viz., that which relates to the different periods of the wooden and brass clock industry or, as it was often dubbed in its earlier stages, "Yankee clock making." Just who was the first to make wooden movements as a business it seems impossible to determine, but available data seems to indicate that the honor is about equally divided between Eli Terry, Gideon Roberts and James Harrison, all of whom commenced about the same time and made similar styles of clocks. As the name of Terry was the more prominently connected with the industry in later years we begin with a sketch of him. First, however, we will give a brief description of the manner in which wooden clocks were made. The accompanying cut will, perhaps, serve to give a better idea than would be gathered from the description alone.

The work, all by hand, of course, was done as follows: The plates were of oak planed

Copyrighted by Chas. S. Crossman, 1885.

down by hand, and into these the pillars, also turned by hand, were inserted. From strips of cherry wood planed down to the desired thickness the blanks for the wheels were cut. The operation being first to prick the centres the correct distance apart, after which the holes for the centre of the wheel were bored and the disks cut out by hand as



ELI TERRY.

shown in the illustration. The blanks were then strung on a wire the size of the centre holes and moistened with linseed oil to prevent crumbling, after which the teeth were cut out by a hand machine or, as some claim, with a saw and jack-knife. The front or driving side of the teeth was straight and the back side slanting or ratchet-shaped. A process similar to the one used to produce

the wheels was also pursued in cutting the pinion leaves, which were made of mountain ivy, a common shrub on the Connecticut hills. Wires were driven into the ends of the pieces for pivots and the pinion turned to the desired size and then leaves were cut.

ELI TERRY.

Eli Terry was born in East Windsor, Connecticut, April, 1772. He obtained his first knowledge of clockmaking from Theodore Harland, a brass clockmaker, of Norwich, Connecticut. Mr. Terry made his first wooden clock about 1791. It has a brass dial and is silver plated, has his name engraved on it, and is cased in a high case of the usual style. It is still running in good order and now belongs to the estate of his grandson, James Terry, of Terryville, Connecticut. Mr. Terry removed to Plymouth in 1793, and immediately began making clocks, both wooden and brass, as a business; making, however, but very few of the brass ones. The demand for clocks was limited as well as the means for making them. He was a young man of great ingenuity and native mechanical talent and, although he never served as a regular apprentice at the trade of clockmaker, he was able to turn out work that was second to none at that time. His work was limited, however, as only three or four clocks could safely be begun at one time. Most of them when completed were delivered to purchasers who had already engaged them. As early as 1797, the genius of Mr. Terry became apparent when he procured a patent on a clock which showed the difference between mean and apparent time. The patent papers bear

CROSS & BEGUELIN,

21 MAIDEN LANE, NEW YORK.

P. O. BOX 531.

WATCHES

Sole Agents for
J. ALFRED JURGENSEN,
CHAS. E. JACOT,
HENRY BEGUELIN.
 ALSO A LARGE STOCK OF
Swiss Watches
 Of All Grades.

JEWELRY

Importers of
DIAMONDS,
 Opera Glasses,
WATCH TOOLS
 AND
 MATERIALS,
WATCHES, GLASSES, Etc.

DIAMONDS

Jobbers in
 ALL MAKES OF
American Watches,
 GOLD, SILVER & PLATED
JEWELRY,
Chains, Bracelets, Etc.
 —
 New Designs Especially Adapted
 to the Season.

TOOLS

NICKEL STEM-WINDING HORSE TIMERS.

Makers of the **Centennial Watch, Centennial Chronograph, Centennial Split Seconds.**

SEND FOR PRICE LIST.

Our Goods are Insured while in Transit. In returning to us, if valuable, Mark Value \$100 on Package.

the autograph signature of John Adams. These clocks were never made, as their cost was too great and they were not practical for ordinary use. Mr. Terry worked alone for several years, but by the year 1800 he had one or two men in his employ, and the business had grown so that they would begin one or two dozen movements at a time. He probably cut the teeth on the wheels himself with a hand engine, such as was used in cutting gear in brass clocks at that time. He may have commenced with sawing out the teeth, but with his knowledge of brass clock-making it is not likely he continued long in that way even if he tried it.

Whichever plan may have been used then, or ever, it was superseded by the invention of Asa Hoppkind in 1813, who constructed an engine with three mandrels, by means of which one tooth on a number of wheels in a stack could be finished at one operation; somewhat as brass wheels are cut at the present time. This machine came into general

more extensively and availed himself of the benefit of water power. In 1806, finding business still increasing, he sold his water power, and machinery to Heman Clark, who had been his apprentice, and bought of Calvin Hoadley an old mill with a better water power and refitted the old mill for a clock factory. After getting his mill fitted up as a clock factory, he began early in 1807 the making of four thousand movements at one undertaking, having made a contract with a firm in Waterbury for a large portion of them. The greater part of the first year was spent in making parts of movements, but during the second year a thousand complete movements of them were finished, and during the third year he finished the remaining three thousand. The success that attended this undertaking was such that it gave a great impetus to wooden clockmaking as a business.

Just here begins the history of Seth Thomas and Silas Hoadley, a son of Calvin Hoadley, as clockmakers. These men had both been employed in different departments in the making of the four thousand clocks. The account book for the years 1808 to 1810 shows that Mr. Thomas did what was then called the joiner work, and also put clocks together, and that Mr. Hoadley made parts of the movements. In 1810 Mr. Terry sold his business to them, and they started as the firm of Thomas & Hoadley. This factory was then the leading one in the country. Mr. Terry, who had acquired a fair competence in his business, moved to a farm in the central part of the township, having contracted not to go into the clock business again. But his restless mechanical genius again asserted

itself, and in 1814 he produced his famous Terry shelf clock, which was soon to supersede the old style of hanging clock. The construction of this clock was new. It was adapted to a short case, the case being part and parcel of the clock and of such dimensions as to be easily transported to any part of the country at but little expense. The clock and case thus became one thing, in contra-distinction to the old





PRIMITIVE METHOD.

use with all makes of wooden clocks. Mr. Terry would make two or three trips each year to what was then called the "new country," across the Hudson River into New York State, taking with him a few clocks which he would sell at \$25.00 each. This price was for the movement only. In 1803, Mr. Terry finding he could sell clocks without being an itinerant himself, made provision for manufacturing clock movements

TELL A. BEQUELIN,

IMPORTER OF

Watches,

Watch Materials, 
 Tools and Glasses

No. 71 Nassau Street,

(UP STAIRS,)

Corner of John Street, NEW YORK.

Sole Importer of Material for the

- "BIJOU,"
- "VICTOR,"
- "BOSTON,"
- "BRISTOL,"
- "ADELPHIA,"
- "JOCKEY CLUB"

AND "NEW HAVEN" WATCHES.

➤ AMERICAN WATCHES, ⚡

ALSO STEM WIND WHEELS

IMPORTER OF

Full Line of **Swiss Watches.**

ALSO IMPORTER OF

FRENCH CLOCK GLASSES.

TO WHOLESALE DEALERS.

WE HAVE FOR IMPORT

A FINE LINE OF

BLACK FOREST

(SCHWARZWALDER)

CUCKOO CLOCKS,

With Brass Movements in dust-proof cases.

E. R. SCHILENCKER, Manufacturer,

Schweningen a/ Neckar,

WURTEMBERG, - - - GERMANY.

IMPORTERS OF
DIAMONDS.

KOCH & DREYFUS,

JOBBERS OF
Watches and Jewelry.

22 John Street, New York.

REPRESENTED ON THE ROAD BY

EMIL SCHORBACH, GEORGE MALLET, SOL. H. VEIT, HENRY HEYMAN, LEO GOLDSMITH.

style of hang-up clock, in which the movement and case are two separate articles. The change of construction was such as to allow of the running of the weights on each side of and the whole length of the case; also locating the pendulum, crown, wheel, and verge in front of the top plate and between the dial and movement, changing the dial wheels from outside to inside of the plate of the movement and changing the escapement by hanging the verge on a steel pin instead of attaching it to an arbor between the plates. These items of change already mentioned, in addition to the fact that the movement was fastened to the back of the case and the pendulum became accessible by removing the dial only, constituted almost a new form of clock and a new manufacture. In justice to Mr. Terry, we can but say that it reflects great credit upon his inventive genius and mechanical ability. This marked a distinctly new era in the clockmaking business, for at the present time there are but few pendulum clocks produced that do not contain more or less of the improvements found in that new construction of shelf clock which Mr. Terry produced in 1814. These things are matters of history and it is our purpose and desire to give credit where it is honestly due, as it is in this case.

In 1815 he obtained consent from Thomas & Hoadley to go into the clock business again; he agreeing, as a consideration, to teach Mr. Hoadley's sons the business. In the Summer of that year he built a shop on the Naugatuck river, about

one mile below the site he had formerly occupied, and the following year he commenced the manufacture of his shelf clock, having in his employ at the time, Chauncey Jerome, who was afterward to become so famous in connection with the clockmaking business in Connecticut. Mr. Terry found all the other clockmakers were taking up the manufacture of his patent shelf clock, either in its original or its subsequently improved form, and brought suits against a number of them. Only one or two, however, ever conceded his claims. He had a long and tedious law suit with Seth Thomas with reference to using his improvements, which finally ended by the suit being withdrawn from the courts.

Mr. Terry also introduced in 1816 his pillar scroll top case, the first one ever produced in the factory being made by Mr. Jerome. He continued to manufacture clocks in the same location until 1823, when he removed to that part of the town of Plymouth now called Terryville, and associated his sons, Eli, Jr., Henry, and Silas B., with him in the business, under the firm name of Eli Terry & Sons. They built a large factory and began operations.

Mr. Eli Terry, Sr., after retiring from business, still continued to make a few clocks.

He turned his attention particularly to making regulators, although he could not be called a brass clock manufacturer. Among other things he invented a peculiar form of gravity escapement about 1850. Scarcely a year passed up to the time of his death with-

out some new design in clock work being invented by him. He was quite a philanthropist and gave away large sums of money, retaining for himself less than he bestowed on others. He died in February, 1852, greatly honored and respected in his community.

Although Mr. Terry had not the advantage of an early education, he was a man of strong mind and sound judgment. He was plain and practical and esteemed that knowledge of most account which had a direct bearing on the concerns of life. His success in the manufacture of clocks when the industry was in its infancy demonstrates his enterprise, sagacity and business capacity.

To Shield His Daughter.

CHICAGO, Ill., Jan. 27.—August Lang is on trial here for smuggling several thousand dollars worth of diamonds. It was proved to-day that his right name is Jacob Kronfeld, formerly an appraiser in the Verkersbank of Vienna, and that he is the son of Dr. A. Kronfeld, a leading Vienna physician. He disappeared on May last, and it was charged that he had forged bills of exchange for 45,000 florins. He testified to-day that his son-in-law was the real forger and that he (Kronfeld) had fled from Vienna to save his daughter from disgrace. The diamonds, he said, were the property of his wife, and he had paid duty upon them. The parties who caused his arrest also testified that they considered him innocent of smuggling.

H. A. WADSWORTH & CO.

MANUFACTURERS OF

GOLD · FILLED · WATCH · CASES,
NEWPORT, KY.



WHEN ANSWERING ADVERTISEMENTS PLEASE MENTION THE JEWELERS' CIRCULAR.

Workshop Notes

Oxidizing Silver.—Dissolve one gram sulphide of potash in one liter water, and heat to boiling. In this bath dip the silver article. The color will be lighter or darker according to the length of time of exposure.

Ordinary Silver Solder.—An ordinary silver solder is made of one part copper and four parts silver. This silver alloy has great firmness and is also ductile to a high degree. It is, therefore, used for soldering articles that are to be worked afterward with the hammer or punches.

Composition Files.—These files, which are frequently used by watchmakers and metal workers for grinding and polishing, and the color of which resembles silver, are composed of 8 parts copper, 2 tin, 1 zinc, 1 lead. They are cast in forms, and treated upon the grindstone; the metal is very hard and is worked with difficulty with the file.

Soft Silver.—Complaints are often made about the brittleness of silver. In a brittle state it is difficult to work with a graver and shows a wet, grey cut. This condition is due to its being cast when too hot. If the crucible with the melted silver is left standing, until a thin film was formed upon the surface and the metal has begun to be pasty, then poured, a white soft silver with a lustrous cut will be the result.

Molding Mass.—A molding mass for coins and medals is obtained by adding to melted thin fluid sulphur about the same quantity of silicious marl and some graphite. (Plumbago.) If this mass, melted over a flame in a spatula or spoon, is rapidly poured over the coin or metal an impression of great sharpness is obtained. Remember, however, to be quick about it as the mass cools rapidly. The plumbago will prevent the work from becoming dull.

Countersinks for Screws in Jewel Settings.—Take a flat brass plate and turn out a cavity just large enough to take in the jewel setting, the jewel being in. In the center of the cavity drill a small hole entirely through the plate. Put the setting in and cement it fast. This plate now represents the balance cock before the counter-sinks or screw-holes are cut. Now make a dot or mark with a fine point of any kind in the plate on each side of the setting just where the center of the screws will come, to correspond in position with the screwholes in the balance cock. Center the plate by one of these balls or marks on a cement chuck of a live spindle lathe, and turn out a counter-sink in both the plate and setting of the size and depth wanted. Then center by the other dot and cut that. Use very sharp, square-faced graver to finish the sides of the counter-sinks. The same plate and hole can, of course, be used for other settings if it be of right size.

USE THE 
AMERICAN MAINSPRINGS
 FOR ALL KINDS OF AMERICAN WATCHES.
 [FACSIMILE OF WRAPPER.]

1 DOZ. MAINSPRINGS

18 S. E. O. S. 

Extra Quality.

TRADE  MARK.

THE BEST IN THE MARKET.

L. H. KELLER & CO.,

Dealers in Fine Watch Materials and Tools.

Agents for the Patek, Philippe & Co.'s Watches.

64 NASSAU STREET, NEW YORK.

WALTHAM DIALS.

WALTHAM DIAL CO.

We desire to call the attention of the trade generally to the fact that they can have duplicated within ten days, at reasonable cost, any kind, shape, size or make of dial. Watch and clock factories supplied with dials for their entire product, or with special designs for their high-grade movements. When large quantities are ordered special rates will be given.

Special attention given to trade-marks, names, emblems, photographs, landscapes. Ornamental work of every description done in black and colors.

WALTHAM, MASS.

WALTHAM DIALS.

GOLD PLATING,

Silver Plating, Etruscan Coloring

AND FIRE GILDING.

LOUIS NEWMAN, Jr.

RESPECTFULLY informs the trade, that he has a **New Process** of Gold Plating, by which very superior work can be done, and which is giving universal satisfaction to the trade. It is also less costly than the old process and in appearance it is equal to gold.

A trial is respectfully solicited, and satisfaction guaranteed.

36 JOHN STREET, N. Y. CITY.

HERMAN GOLDSMITH,

RUBIES, * * * ALEXANDRITES,
 EMERALDS, * SPINELS, * *
 SAPPHIRES, PEARLS,
 AND ALL OTHER PRECIOUS STONES.

33 & 35 John Street,

NEW YORK.

* 25 HATTON GARDEN, LONDON. *



A Wonderful
TOOL
FOR THE BENCH.

Instantaneous in Its Work!

Dividing the inch into one thousand parts. A most practical tool for watchmakers for gauging from a hair-spring to a main-spring. Non-comparable for a height and depth gauge. Instantaneous for hair-spring work.

For sale by all Jobbers.

NORDMAN BROTHERS,
120 Sutter St., SAN FRANCISCO, CAL.
Sole Agents for the United States.

BOOKS FOR JEWELERS.

W. B. DICKIE,
67 William Street, New York,
PUBLISHER OF
Improved Watch Stock Book

— AND —

Improved Watch Repair Book.

SEND FOR DESCRIPTIVE CIRCULAR.

H. H. HEINRICH,
12, 14 & 16 John St., New York,
Manufacturer of

MARINE CHRONOMETERS.

Silver Medal, Paris Exhibition, 1889.
A large stock of new and second-hand Marine Chronometers, on hand. All my second-hand Chronometers are thoroughly overhauled, refinished and re-adjusted. Rented out at \$5.00 per month, payable in advance. No rent charged if bought within a certain time. Terms to suit customers. Marine Chronometers repaired and adjusted for the trade.



ESTABLISHED 1863.

J. BECK & SON,

MANUFACTURERS OF

Solid Gold and Silver Chains, and Jewelry,
NO. 10 LIBERTY PLACE.

Near Maiden Lane,

NEW YORK.



TRADE MARK.

THE ORIGINAL

GOLD CROWN

FILLED RINGS



SECOND QUALITY.

TO MEET the demand for a lower priced Gold-Filled Ring, we are now making, in connection with the Crown Ring, a Second Quality Ring, stamped as above.

WE MANUFACTURE FOR THE JOBBING TRADE ONLY.

McCALL & NEWMAN, - - 625 Arch Street, Philadelphia.

It will pay you to send for PRICE LIST just issued by the

EMPIRE PLATING WORKS,

E. F. PIERDON, PROP.

I. VALLENTINE, MANG'R.

75 & 77 NASSAU STREET,

Ground Floor, Rear.

NEW YORK.

We do all kinds of GOLD and SILVER PLATING and COLORING,
and guarantee first-class work at lowest prices.

WATCH CASE PLATING AND ETRUSCAN COLORING, OUR SPECIALTIES.

WATCH CASE AND JEWELRY REPAIRING.

HENRY FERRA,
Importer of DIAMONDS and
DIAMOND BORTZ.

Diamond Cutting and Polishing Establishment,
10 MAIDEN LANE, NEW YORK.

S. Valfer & Co.,

66 Nassau St.,
New York,

Will produce some new designs in Boxes and Trays this month.

Send for Catalogue or samples on approval, or both.

Fashions in Jewelry.

A Lady's Ramble Among the Jewelers.

The stork lends itself as a model for button-hooks.

Very dainty are the solid silver scalloped butter shells.

A lyre-shaped Empire clock affords a pleasing variation.

The taste for miniature watches and time-pieces is at its height

The turquoise was never more popular than at the present time.

Sterling silver cases for spectacles are decorated with antique chasing

Quite new in brooches are heart-shaped amethyst ones encircled with pearls.

Very new and very handsome are the monogram letter clips in solid silver.

Repoussé and chased work is exceedingly fashionable now in silver table ware.

The present fad in padlock bracelets is for those having either heart-shaped or square locks.

Girdles continue in fashion, a favorite kind being copies of those worn in mediæval times.

Crushed morocco is the very newest material for covering bags and all fancy leather goods.

Novel scarf-pins are mounted with finely enamelled miniature heads in square diamond settings.

The very latest in photograph frames are those that show a combination of tortoise shell and silver.

The very prettiest paper-weights are silver see-saws on the ends of which are placed pretty little Viennese bronzes.

Silver flower vases are very much the rage and are made in a variety of shapes. One takes the form of a cornucopia.

Tiny balls encrusted with diamonds and set as scarf-pins and sleeve links, are extremely popular among gentlemen.

Decidedly unique are the new spoons, the chased handles of which are pierced until they produce quite a lace-like effect.

The long chains of twenty odd years ago have returned to us, and with them comes the old slide chain with jeweled slide.

New brooches come in oblong, round, heart and double-heart shapes. It is not possible to say which is the most fashionable.

A novelty in cigarette cases is shaped like a portmanteau, opening in the centre and disclosing its contents neatly packed on either side.

A novelty likely to outlive the season that introduced it is the mistletoe-bough brooch with its enamelling of tendrest green and berries of pearls.

It is a fact beyond dispute that coral is again fashionable. One sees it in scarf pins and brooches bordered either with small diamonds or pearls.

The very latest in cut-glass scent bottles has a silver bird perched on the stopper. On pressing the latter, the bird emits a spray of perfume from its beak.

Costly trifles are bon-bon dishes in silver. Modern patterns are heart-shaped with pierced borders. Silver shells are also used as bon-bon trays.

In much of the new jewelry, diamonds and pearls have changed places, pearls forming the *pièce de résistance* of the ornament and the diamonds serving as an enhancement of their beauty.

The watch is making itself quite at home in all sorts of odd places. We find it in umbrella handles, the tops of ink-stands, in calendars, and hidden away in the heart of rose pendants.

A unique arrangement consists of a richly-chased gold bird, worn as an order upon the front of the dress bodice and having suspended from it a watch in the guise of an enamelled medal.

The old-time combination of turquoises and diamonds which has been revived in necklaces is sure to be prized, because they enhance the whiteness of the neck and are otherwise becoming.

ELSIE BEE.

ESTABLISHED 1841.

CARTER, SLOAN & Co.

MANUFACTURERS OF

FINE JEWELRY,

15 MAIDEN LANE, NEW YORK.



A. CARTER, JR.
A. K. SLOAN.
C. E. HASTINGS.
GEO. R. HOWE,
WM. T. CARTER,



Factory, NEWARK, N. J.

61 WEST FIFTH STREET.



WE have removed to the above address, where we would be pleased to see our friends.   

A. G. SCHWAB & BRO.

WHOLESALE JEWELERS,
CINCINNATI, OHIO.



New Goods for the **SPRING SEASON.**
NOVELTIES OF ALL KINDS IN JEWELRY,
AND A NEW LINE OF WATCHES AND DIAMONDS.

PETER HENRY,
MAKER OF
Special Watch Cases
For American, English and Swiss Movements,
No. 56 Longworth Street,
Room 4, Second Floor, CINCINNATI, O.
Key Winders changed to Stem Winders.
English Cases changed to American Movements.
Hunting Cases changed to Open Face.
Old Watch Cases Reconstructed, Repaired and Renewed.
LOW PRICES, GOOD WORK AND PROMPT ATTENTION GUARANTEED.

HENRY TROEMNER,
No. 710 Market Street, PHILADELPHIA.

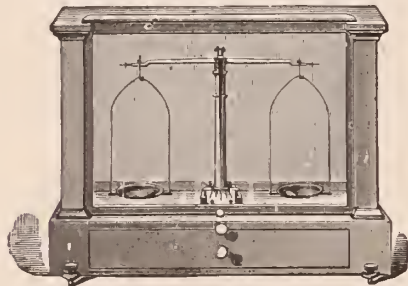

Manufacturer of FINE GOLD SCALES and DIAMOND SCALES.
Bullion Balances and Weights, in use at all the U. S. Mints and Assay Offices. Priced Catalogue on application.



Established 1872.

PLAINVILLE STOCK CO.

P. S. CO.

THIS TRADE-MARK REGISTERED, AND STAMPED ON ALL OUR GOODS.

BROOCHES, SCARF PINS, DROPS, SETS.

FACTORY AT PLAINVILLE, MASS. SAMPLES AT 176 BROADWAY, NEW YORK.

BEST and CHEAPEST DEVICE FOR MAILING

All Mailable Matter at Cheap Postage.

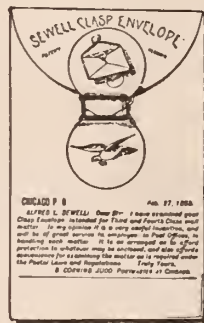

For mailing Trade Catalogues, Samples, Parcels of DRY GOODS, WOOL, YARN, COTTON, SEEDS, GROCERIES, PHOTOGRAPHS, DRUGS, WHEAT, FLOUR, GLOVES, LACES, RIBBONS, CALENDARS, SAMPLE CARDS, and all other 3rd and 4th class mail matter, is

SEWELL'S PATENT ENVELOPE CLASP,
(Patented in America and Europe.)
WHICH FITS ON ANY ENVELOPE IN THE MARKET.

In a moment it turns any envelope into a CLASP ENVELOPE. It is made of tough sheet brass. Anybody can put it on, as it is most convenient, and adjusts itself to a package of any size or thickness. It is endorsed by Postmasters.

We also make Envelopes, all sizes and kinds.

SAVE MONEY, and GET THE BEST, by writing for samples and prices to the

CHICAGO ENVELOPE CLASP CO.,
210 South Water St., CHICAGO, ILL., U. S. A.

ENVELOPES

FOR JEWELERS' AND OTHER TRADE CATALOGUES.

Recent Patents.

Issue of December 23, 1890.

DESIGN No. **20,127** and **20,428**. HANDLE FOR SPOONS, &c. AUSTIN F. JACKSON, Taunton, Mass., assignor to The Reed & Barton Corporation, same place.—Applications filed November 17, 1890. Serial Nos. 371,742 and 371,743. Term of patent seven years.

DESIGN No. **20,129** to **20,433**, inclusive. BACKS OF BRUSHES, MIRRORS, &c. AUSTIN F. JACKSON, Taunton, Mass., assignor to The Reed & Barton Corporation, same place.—Applications filed November 17, 1890. Serial Nos. 371,745 to 371,749, inclusive. Term of patents seven years.

TRADE MARK No. **18,719** CROCKERY, GLASS AND PLATED WARE. E. LOBE & Co., Seattle, Wash.—Application filed March 27, 1890. Used since January, 1883. "The words 'Golden Rule Bazaar.'"

TRADE MARK No. **18,740**. WATCH-SPRINGS. LOUIS COMBREMONT, New York, N. Y.—Application filed October 3, 1890. Used since July 1, 1890. "The representation of the statue and name of 'Daniel Jeanrichard.'"

443,094. JEWEL-BOX. HENRY T. HERMANN, Antigo, Wis.—Filed Nov. 14, 1889. Serial No. 339,328 (No model.)

443,160. SPECTACLES. JAMES E. BRIGGS, Rochester, N. Y.—Filed Feb. 12, 1890. Serial No. 340,444 (No model.)

443,165. BALANCE-ESCAPEMENT. CHARLES E. EMERY, Brooklyn, N. Y. Filed Jan. 20, 1890. Serial No. 337,413. (No model.)

443,256. MAKING HAIR-SPRINGS FOR WATCH-BALANCES. JOHN LOGAN, Waltham, Mass.—Filed Oct. 9, 1890. Serial No. 367,524. (No model.)

443,425. JEWELRY. JULIUS BONNER, New York, N. Y. Filed July 5, 1890. Serial No. 357,820. (No model.)

Claim.—A catch for bars of ear-rings, lace-pins, and other articles, said catch consisting of two hooked branches joined by an incline, in combination with a swivel-support, substantially as described.

443,480. WATCH-CASE PENDANT. CHARLES W. HATHAWAY, Philadelphia, Pa., assignor to H. Muhr's Sons, same place.—Filed Feb. 17, 1890. Serial No. 349,705. (No model.)

Issue of December 30, 1890.

443,943. ALLOY. IRA H. JOHANNES, Washington, D. C.—Filed June 21, 1890. Serial No. 356,275. (Specimens.)

Claim.—1. An alloy consisting of aluminum in amount equal to or exceeding fifteen parts, by weight, and a combined amount of antimony and lead equal to or less than eighty-five parts, substantially as described.

2. An alloy consisting of aluminum in an amount equal to or exceeding fifteen parts, by weight, and a combined amount of tin, antimony, and lead equal to or less than eighty-five parts, substantially as described.

TRADE MARK No. **18,757**. WATCH-SPRINGS, PIN-TONGUES AND CASE-SPRINGS. BENJAMIN ALLEN, Chicago Ill.—Application filed February 15, 1890. Used since October, 1887.

"A diamond-shaped figure, having thereon the letters and symbol 'B A & Co.'"

443,684. BALANCE-ESCAPEMENT. SIGISMUND RIEFLER, Munich, Bavaria, Germany.—Filed May 6, 1889. Serial No. 309,752. (No model.) Patented in England April 23, 1889, No. 6,809; in Belgium April 30, 1889, No. 86,905; in Switzerland May 7, 1889, No. 850; in France June 20, 1889, No. 197,637, and in Germany February 12, 1890, No. 50,739.

443,695. MECHANISM FOR TESTING WATCHES. BROMMIE CORTLAND, Salem, N. Y.—Filed April 29, 1890. Serial No. 349,885. (No model.)

443,698. PLATED WIRE. GEORGE U. MEYER, Providence, R. I.—Filed Oct. 21, 1890. Serial No. 368,783. (No model.)

443,788. WATCHMAN'S ELECTRIC TIME-RECORDER. CHARLES E. ONGLEY, New York, N. Y., assignor of one-third to Thomas W. Robertson, same place.—Filed March 17, 1890. Serial No. 344,166. (No model.)

443,881. MAINSPRING-WINDER. ALDEN R. VAUGHAN, Pawtucket, R. I. Filed May 23, 1890. Serial No. 352,904. (No model.)

443,787. WATCHMAN'S ELECTRIC TIME-RECORDER. CHARLES E. ONGLEY, Yonkers, N. Y. Filed Jan. 20, 1890. Serial No. 337,424. (No model.)

443,790. ELECTRIC PROTECTIVE AND SIGNALING SYSTEM. CHARLES E. ONGLEY, Yonkers, N. Y.—Filed Nov. 26, 1889. Renewed Nov. 8, 1890. Serial No. 370,728. (No model.)

443,869. MICROMETER-GAGE. JACOB W. RIGLANDER, New York, N. Y.—Filed March 27, 1890. Serial No. 345,580. (No model.)

Issue of January 6, 1891.

DESIGN No. **20,440**. BADGE. WILLIAM H. BROOKS, Philadelphia, Pa.—Application filed December 1, 1890. Serial No. 373,220. Term of patent fourteen years.

DESIGN No. **20,453**. BADGE. EDWIN W. LAWSON, Elgin, Ill.—Application filed October 24, 1890. Serial No. 369,234. Term of patent 3½ years.

DESIGN No. **20,460**. WATCH-MAKER'S SIGN. LOUIS SOLON GROUT, Chicago, Ill.—Application filed November 10, 1890. Serial No. 370,960. Term of patent seven years.

DESIGN No. **20,466**. HANDLE FOR SPOONS, &c. CHARLES OSBORNE, New York, N. Y., assignor to the Whiting Manufacturing Company, same place.—Application filed December 2, 1890. Serial No. 373,371. Term of patent 3½ years.

A. WITTNAUER,

Successor to J. EUGENE ROBERT & CO.,

No. 30 MAIDEN LANE, NEW YORK,

MANUFACTURER AND IMPORTER OF

WATCHES AND WATCH MOVEMENTS.

AGASSIZ

AND

LONGINES

MOVEMENTS,

FITTING

6, 16, 18 Size Cases, in 3 Grades.



SOLE AGENTS FOR

LOUIS AUDEMARS

AND

JULES MONARD,

GENEVA

Unexcelled Timekeepers.

CHRONOGRAPHS, SPLIT SECONDS, MINUTE REPEATERS, &c.

16 and 18 Size Movements, Open Face and Hunting.

Thoroughly Adjusted for Accurate Time and Railroad Use.

DESIGN No. **20,172**. BACK OF BRUSHES, &c. AUSTIN F. JACKSON, Taunton, Mass., assignor to The Reed & Barton Corporation, same place.—Application filed November 17, 1890. Serial No. 371,744. Term of patent seven years.

TRADE MARK No. **18,775**. MUSIC-BOXES. M. J. PAILLARD & Co., New York, N. Y.—Application filed November 14, 1890. Used since April 15, 1874. "The words 'Sublime Harmonie'."

TRADE MARK No. **18,795**. TABLE CUTLERY. AMERICAN CUTLERY COMPANY, Chicago, Ill.—Application filed October 27, 1890. Used since April, 1890.

"The representation of a keystone."

441,081. BALANCE-WHEEL. JOHN S. WRIGHT, Greenfield, Mass.—Filed Aug. 19, 1890. Serial No. 362,451. (No model.)

441,362. EYEGLASSES. HENRY E. KIRSTEIN, Rochester, N. Y.—Filed April 8, 1890. Serial No. 347,115. (No model.)

Issue of January 13, 1891.

DESIGN No. **20,475**. HANDLE SOCKET AND PLATE. MAX BREMER, New Bedford, Mass., assignor to The Pairpoint Manufacturing Company, same place.—Application filed August 1, 1890. Serial No. 360,718. Term of patent fourteen years.

441,458. WATCH-REGULATOR. CHARLES NOBS, Newark, N. J.—Filed June 13, 1889. Renewed Sept. 27, 1890. Serial No. 366,309. (No model.)

441,602. TRANSIT-INSTRUMENT. CLINTON SUTHERN, New York, N. Y., assignor to one-half to Eugene H. Hinton, same place.—Filed May 27, 1890. Serial No. 353,364. (No model.)

441,684. CLOCK-PINION. ARCHIBALD BANNATYNE, Waterbury, Conn., assignor to the Waterbury Clock Company, same place.—Filed Feb. 7, 1890. Serial No. 339,553. (No model.)

DESIGN No. **20,476**. WATCH-CASE. JOHN C. DUEBER, Newport, Ky.—Application filed December 5, 1890. Serial No. 373,728. Term of patent fourteen years.

DESIGN No. **20,477**. JEWEL-SETTING. LOUIS MANN, New York, N. Y.—Application filed October 21, 1890. Serial No. 368,866. Term of patent seven years.

DESIGN No. **20,483**. WATCH-BRIDGE. ADRIEN PHILIPPE, Geneva, Switzerland, assignor to Patek, Philippe & Co., same place. Application filed September 11, 1890. Serial No. 365,550. Term of patent fourteen years.

TRADE MARK **18,838**. ARTICLES MADE WHOLLY OR IN PART OF SILVER. DANIEL LOW, Salem, Mass.—Application filed October 3, 1890. Used since July 1, 1890. "The word 'Witch.'"

TRADE MARK **18,881**. WATCHES. JULES RACINE & Co., New York, N. Y., and Chicago, Ill.—Application filed December 4, 1890. Used since July 1, 1883. "The word 'Success.'"

TRADE MARK **18,882**. WATCHES. JULES RACINE & Co., New York, N. Y., and Chicago, Ill.—Application filed December 4, 1890. Used since July 1, 1889. "The words, 'National Park.'"

441,673. JEWELRY. LUDWIG J. ROEHR, Newark, N. J.—Filed March 28, 1890. Serial No. 345,659. (No model.)

Claim.—A lock for bracelets and the like, comprising a locket or other ornament, a hollow split ring secured thereto and carrying a spring, and a locking-bolt working in said hollow split ring and engaging in a holding relation with a suitable seat, thereby closing the ring, said split ring being adapted to engage the opposite ends of a bracelet or necklace, as shown and described, for the purposes set forth.

441,495. TRIAL SPECTACLE-FRAME. GEORGE JOHNSTON, Detroit, Mich.—Filed May 31, 1890. Serial No. 353,711. (No model.)

441,505. TEMPLE FOR SPECTACLE-FRAMES. BENJAMIN I. PRICE, Denver, Colo.—Filed March 8, 1890. Serial No. 343,183. (No model.)

Issue of January 20, 1890.

DESIGN No. **20,485**. WATCH-CHARM. THOMAS

TUGBY Niagara Falls, N. Y.—Application filed November 1, 1890. Serial No. 370,084. Term of patent seven years.

441,985. FOUNTAIN PEN. LOUIS BERNHARD, Bloomsburg, Pa.—Filed Dec. 17, 1889. Serial No. 334,123. (No model.)

445,002. JEWEL-CASE. HINRICH GROHBRUGGE, New York, N. Y.—Filed Sept. 11, 1890. Serial No. 364,601. (No model.)

445,023. INDEPENDENT ELECTRIC CLOCK. EDOUARD LEFEBVRE, Montreal, Canada.—Filed Oct. 6, 1890. Serial No. 367,222. (No model.)

445,064. STOP-WATCH. EDMUND KUHN, Brooklyn, assignor to the Manhattan Watch Company, New York, N. Y.—Filed March 21, 1890. Serial No. 344,743. (No model.)

445,073. CLOCK-WINDING MECHANISM. WILLARD PACKER and William W. Bradley, Canton, Ohio.—Filed May 5, 1890. Serial No. 359,558. (No model.)

Issue of Jan. 27, 1891.

TRADE MARK **18,905**. COMPOUNDS FOR CLEANING AND POLISHING METALS. WILLIAM J. LADD, New York, N. Y.—Application filed in December 9, 1890. Used since May, 1888. "The word 'Prestoline.'"

TRADE MARK **18,906**. TABLE-WARE TECHNICALLY KNOWN AS FLAT WARE. WILLIAM H. LYON, Newburg, N. Y.—Application filed December 5, 1890. Used since September 1, 1890. "A representation of the building known as 'General Washington's headquarters at Newburg.'"

445,317. FOUNTAIN PEN. GEORGE H. JONES, London, England.—Filed May 28, 1889. Serial No. 312,378. (No model.) Patented in England, May 16, 1888, No. 7,293.

Who Will Spare Them.

FRANKLIN, Ind., Jan. 15, 1891.

I enclose order for amount due on my subscription, as I will not be without THE CIRCULAR. I wish you success and a larger circulation than ever; and may THE CIRCULAR continue—
CHAS. A. BECK.

Mr. Beck also asks for some back numbers. We have sent him the numbers he asks for except the following: Oct., 1885; Dec., 1885; Jan., 1886. If any of our readers have these copies on hand and will spare them, Mr. Beck will pay 25 cents each for them. He says he does not care for the ads., but wants the reading matter to be in good condition.

Jules Jürgensen

OF COPENHAGEN.

The reputation these watches have maintained for Fifty Years has never been equalled, being made on strictly scientific principles, and no expense spared to give the Best results in mechanism and timekeeping qualities.

SOLE AGENTS,

John G. Hyde's Sons,
No. 22 Maiden Lane.

✱ **Towle Mfg. Co.,** ✱

MANUFACTURERS OF



Sterling Silverware

NEWBURYPORT, MASS.: 214 MERRIMACK ST.



CHICAGO:
149 & 151 STATE ST.

SAN FRANCISCO:
220 SUTTER ST

Essex Watch Case
COMPANY.

T. B. HAGSTOZ, President.

TRADE MARK



6 Maiden Lane, N. Y.

OFFICE,

NEWARK, N. J.
FACTORY.

GOLD FILLED CASES.

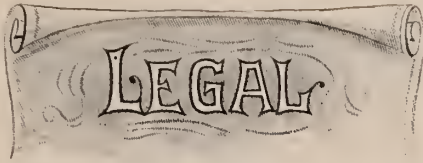

COPYRIGHTED 1890, LAW NEWS BUREAU.
CONSPIRACY TO DAMAGE BUSINESS.

Where persons conspire together to injure the business of another by circulating false reports of his financial condition and business habits among his customers and his creditors, a civil action will lie for the damages sustained, and the essence of the action is not so much the conspiracy, which is merely an accident, as it is malice, which is the element of the offense.

LIABILITY OF BANK FOR FORGED CHECK.

A customer of a bank took to it a check to be cashed which the cashier refused to cash because it had some appearances of having been raised. It was accepted for collection, and forwarded to a correspondent of the bank which credited it with the check. It was then credited to the depositor. Subsequently it came back from the bank on which it was drawn rejected, because it had been raised from the amount for which it was originally drawn. It was then charged to the depositor's account. The latter was not entitled to recover this from his bank on the ground of negligence, nor did the fact that it had been, under these circumstances credited to his account, give him the right to recover.

PRECAUTIONARY MEASURES REQUIRED OF EMPLOYER.

An employer is bound to provide his employes with a safe place and safe appliances to do the work required of them, but when all the dangers which past experience or the exercise of a proper degree of prudence would lead him to anticipate have been guarded against, the duty of the employer is fulfilled, and he cannot be held responsible for results which could not naturally be expected to follow from his exactions from the workmen.

RETAINING CHECK UNCASHED.

Where one sends a check in payment of an account, which is expressed on its face to be "in full of account to date" but which is in fact for less than the amount of the debt due, no loss is suffered by the drawer, by reason of the fact that the payee neither returns the check until suit is brought, nor presents it for payment, and therefore he is entitled to no credit on that account. A check is not payment until cashed.

LEXINGTON Mo., Jan. 15, 1891.

We are very much pleased with the whole work of THE CIRCULAR. Our Mr. C. O. Grimes is the oldest jeweler in this State, having begun trade in Lexington, Ky., in 1846 and followed it ever since. He knows many of the old land-marks in the trade.

GRIMES & VENABLE.

ESTABLISHED 1873.

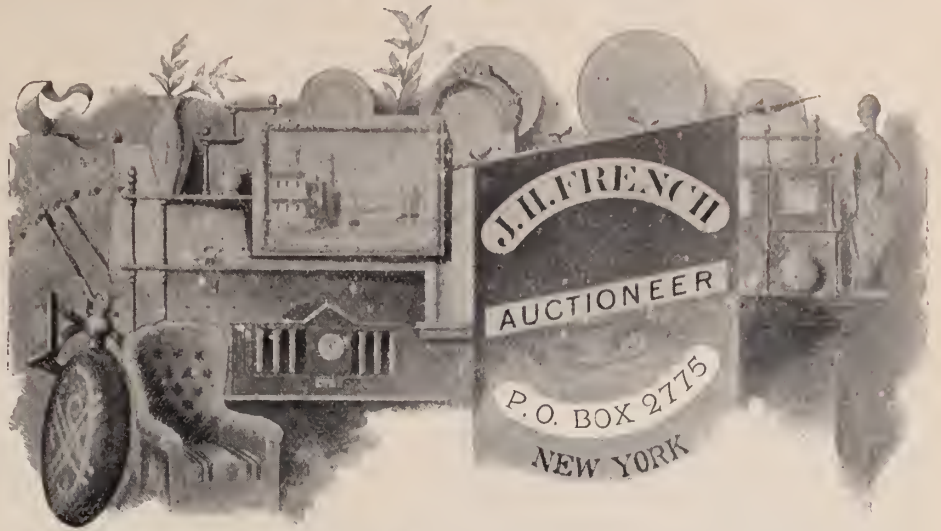

If for any reason you should desire the services of an AUCTIONEER, and will write me as to the amount of stock you have on hand and its general character, the size of your store and the number of inhabitants of your town or city, I could, from my extended experience, give you an idea of the amount of business you could expect under the circumstances, and, no doubt, be able to refer you to some one for whom I have sold under conditions similar to your own.

As a general reference, you could hardly find a wholesale jeweler who is not familiar with some of the numerous successful sales I have made.

I have made many successful AUCTION SALES, and have yet to record a failure to fully satisfy the owners. Can give you hundreds of references to that effect.

If the business should be urgent and I am myself engaged, I have two competent assistants instructed in my methods whom I could send on short notice.

Any correspondence with me will be strictly confidential in every case.
P. O. Box 2775.

NEW YORK CITY.

WE DESIRE to call your attention to our large and varied assortment of

Complicated, High Grade Gentlemen's and Ladies'



In Gold Cases, both Plain and Enameled, in Choice Designs.

THE LARGEST STOCK EVER SHOWN IN THIS COUNTRY.

NON-MAGNETIC WATCH CO.

OF AMERICA,

CHAS. MCCULLOH, RECEIVER,

177 Broadway. = = NEW YORK.

N. J. FELIX,

(ESTABLISHED 1865.)

MANUFACTURER OF
GOLD and SILVER WATCH CASES,
ROOMS 6, 7 AND 8,
71 Nassau St., New York.



BEFORE-FRONT VIEW.

Old English Cases altered to Stem-Winding; also to Imitation Stem-Winding with key attachment to crown. Bezels altered to take flat glasses.

SEND FOR PRICE LIST.



AFTER.



BEFORE-BACK VIEW.

Orders or jobs sent me by mail or express always receive prompt and careful attention. As for references where he is not known, Mr. Felix can confidently state that he has done work continuously for the last twenty-five years for the very best houses in New York.

American Morocco Case Co.

FINE EBONY AND ROSEWOOD TRAYS.

ONLY MAKERS OF

SATIN FINISHED WHITE METAL CASES FOR RINGS, BROOCHES, EARSTUDS, COLLAR BUTTONS, ETC.

*Fine Velvet and White Leather Cases for
Diamond Jewelry.*

9 Bond Street, N. Y.

*Polished Hard Wood Trunks for Combi-
nation Sets and Single Spoons.*

RYDER & DEARTH
DESIGNERS & ENGRAVERS

Fine Commercial and Copper-Plate Printers.

A Specialty of

Jewelers' Printing, Cuts and Electrotypos.

Headquarters for JEWELERS' CARDS.

BEST WORK,

PROMPT DELIVERY,

LOW PRICES.

No Order Too Large! None Too Small!

146 Westminster Street,

PROVIDENCE, - RHODE ISLAND.

MUSICAL JACOT & SON
298 Broadway,
New York.

Send for Catalogue.

BOXES.

Musical Boxes Repaired.

ONE OF THE OLDEST RESTAURANTS
DOWN TOWN.



POPULAR PRICES

HOW TO RECOGNIZE THE TRUE

WEBSTER-WHITECOMB · LATHE.

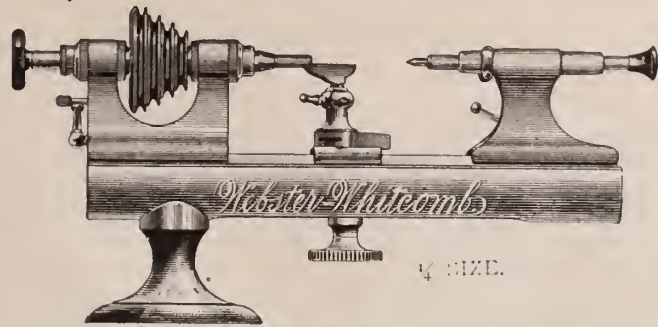

THIS question is often asked: "How shall I recognize an *imitation* from the *true* 'Whitcomb' or 'Webster-Whitcomb' lathe?" To this we reply: "All our lathes bear the word 'Whitcomb' or 'Webster-Whitcomb' also the word 'hard' or 'soft' to indicate the temper of the bearings, also the number of the lathe (all of our lathes being numbered consecutively) either on the bed or the headstock (latterly on the headstock only). The bed always bears the words 'American Watch Tool Co., Waltham, Mass.' The words 'Whitcomb' and 'Webster-Whitcomb' are our trade-marks, and up to the present time no imitator has dared to use them. The first attempt to use them or our patented features will be immediately followed by a suit at law. With every lathe we send the following guarantee:—

"This certifies that the lathe marked 'American Watch Tool Co., No. —' was made by us from the best materials, on the most approved plan, and is a reliable lathe. For any defect in material or workmanship we hold ourselves responsible. Notify us promptly of any faults.
 Waltham, _____ By _____"

This guarantee is also signed by the inspector who has the final inspection of the work. For several years past we have tied upon every lathe a tag of caution and instruction. All purchasers are requested to demand these documents with the lathes they buy. Remember our address:

AMERICAN WATCH TOOL CO.,

WALTHAM, MASS.

STONY BATTER WORKS.

CHAS. F. WOOD.
 IMPORTER OF
DIAMONDS,
 PEARLS,
 SAPPHIRES,
 AND
 RUBIES,
 EMERALDS,
 PRECIOUS STONES
 OF ALL KINDS.
 169 AND 171 BROADWAY.
 NEW YORK.



B. & W. B. SMITH,

220 West 29th Street, New York City.

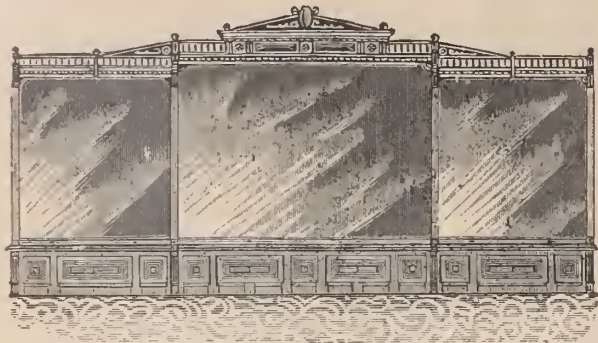

WALL CASES with Perpendicular Sliding Sash—Dust Tight—with our Improved System of Shelving for Silverware and other Goods.

ATTENTION.

We make Cases and have them on exhibition at our factory, of any size and shape of plate glass and with wood moulding, as small as an eighth of an inch in diameter.

Catalogue of Illustrations Issued.

CALL AND SEE US. ♦ ♦ ♦ ♦

♦ ♦ ♦ ♦ CORRESPONDENCE SOLICITED.

WE MAKE TO ORDER ONLY.

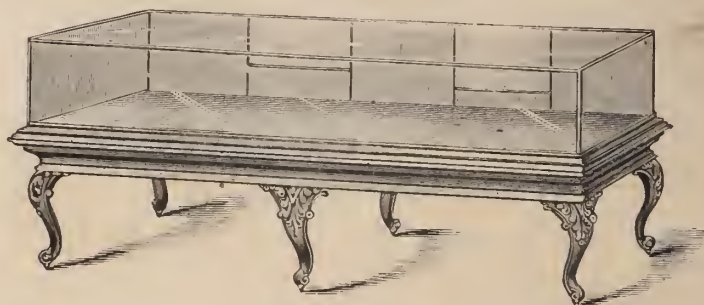

COUNTER CASES with our Dust Tight, Perpendicular Sliding Doors. Any Hardwood and Imported Plate Glass. Table or Counter with adjustable jack for any uneven surface.



STOP!

S. P. HOWARD,
Gold and Silver Assayer,
Refiner and Sweep Smelter,
8 & 10 JOHN STREET, NEW YORK.
Smelting and Refining Works,
28, 30 & 32 Cumberland St., Brooklyn, N. Y.
Specialities: Sweepings, Gold, Silver and Platinum.

S. F. MYERS & CO., Wholesale Jewelers.

EVERYTHING
THAT
PERTAINS
TO THE
JEWELRY TRADE.

22
DEPARTMENTS.



WE REQUIRE
AND OCCUPY THE
LARGEST
SALESROOMS
IN OUR LINE.
4 STORES.
GROUND FLOOR.

48 & 50 Maiden Lane and 33 & 35 Liberty Street, New York.
CONSULT OUR MAMMOTH CATALOGUES.

ALBERT LORSCH & CO., 37 Maiden Lane, New York.

P. O. BOX 2139.

167 Broad St. (P. O. Box 941), Providence, R. I.

IMPORTERS OF
DIAMONDS, PRECIOUS AND IMITATION STONES.

Sole owners and Importers of

Unequaled in

The Sumatra Gem.
REG'D.

Brilliancy.

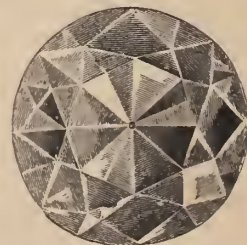
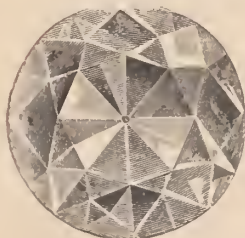

The nearest approach to the Genuine Diamond. For sale by all leading Manufacturers and Jobbers. * All Jewelry set with these Stones is sold on cards stamped "The Sumatra Gem, Reg'd."

L. & M. KAHN & CO., Importers of **DIAMONDS,** 10 Maiden Lane, N.Y.

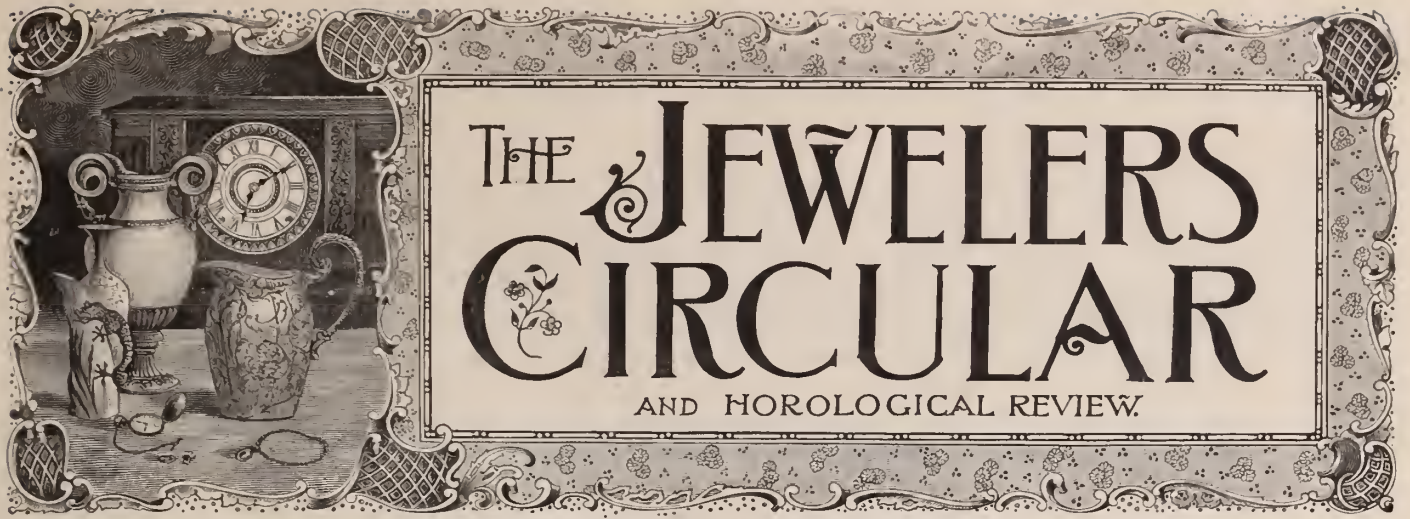

Entered at the Post Office in New York as second-class matter.

VOL. XXII.

NEW YORK, WEDNESDAY, FEBRUARY 11, 1891.

No. 2.

CHICAGO AND MONTREAL.

FOLLOWING closely upon the banquet of the New York Jewelers' Board of Trade, which was celebrated in this city on January 21, came the dinners of two other jewelers' associations; the one in Chicago and the other in Montreal.

Enthusiasm among the jewelers concerning their trade organizations has been greatly stimulated since the cessation of the rush of the holiday trade has given them the opportunity to relieve their minds from press of individual business and devote

crease and grow stronger during the year, and that these twelve months will record better results than the last. No meeting held this year has lacked any of the essentials that make for success, and every organization has found cause for pride and self-gratulation.



M. N. BURCHARD.

President of the Chicago Jewelers' Association.



M. N. ELLIS.

President of the Canadian Association of Jobbers.

Though separated by many leagues and divided by allegiance to two different powers, their trade interests are identical and they are both striving for one object, viz.: the improvement of the jewelry trade the world over.

a part of their time to the consideration of matters that make for the benefit of the trade at large, and for cultivating the sociability and fraternal spirit that should exist among them. And there is no present indication that this fellowship will not in-

The accompanying cuts are portraits of M. N. Burchard, President of the Chicago Jewelers' Association, and M. C. Ellis, President of the Canadian Association of Jobbers in American Watches. A sketch of both of these gentlemen will be found on page 61.

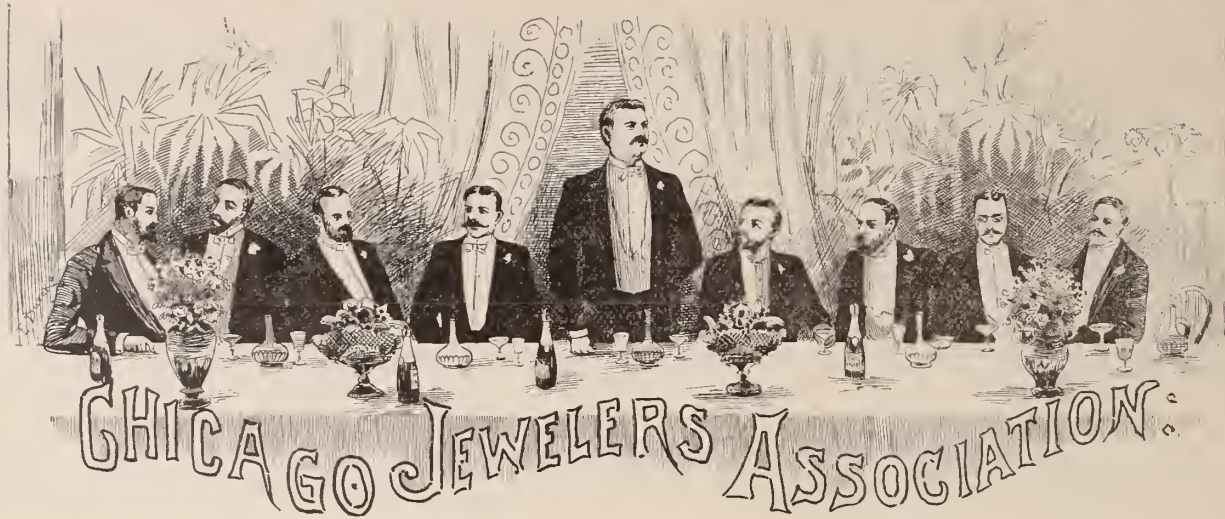

THEY ENJOY A SOCIAL EVENING.

A PLEASANT TIME FOR OUR BROTHERS IN THE WEST.

It was a gem of the first water, and was admitted "To assay 22 Karats."

These and other observations which were plentiful but inadequately describe the banquet of the Chicago Jewelers' Association. It was held Thursday, February 5, at the Auditorium, and was the fourteenth annual event of the kind in the history of the organization. The banquet hall of the Auditorium is pronounced the most magnificent in America, and the jewelers' spread was the finest ever laid in the hall. Two superlatives in the same connection.

Diamonds flashed from every shirt front and from fobs appended to gem-studded watches. It might from the brilliancy of the display of gems have been mistaken for an assemblage of foreign princes and potentates, or a convention of millionaires. The association proper contains but forty members. The remainder of the 150 present were their guests. All thoroughly enjoyed the affair.

Shortly before eight o'clock the members and their friends began the march from the hotel parlors to the hall of feasting. The board was arranged in the form of a horse-shoe, and from it rare-tinted and numberless fairy lamps flashed back the bright rays of the hundreds of incandescent lights dependent from the ceiling. Each light was again reflected in flashes from the dainty china and costly cut glass. Among the treasures of the table Easter lilies, rare roses and violets with others of their flowery kin smiled and made the air heavy with perfume. Between the arms of the horse-shoe formed by the tables was an immense bank of blossom and brightness.

From a balcony concealed with screens and palm plants the celebrated Vallis's Spanish orchestra sent their strains. For a time the music drowned the tinkling of glasses and clink of the silver. But eventually good cheer reigned supreme.

For nearly three hours the table attendants were busy catering to the needs of the guests. The menu lacked nothing as may be seen from the following:

MENÜ.

Blue Points.
Celery.
Green-Turtle Soup.
Filet of Pompano, Fine Herb Sauce
Radishes. Curled Potatoes.
Supreme of Prairie Chicken, with Truffles.
Asparagus Points.
Sweetthreads Larded, with French Peas.
Frozen Tomatoes. Mayonnaise.
Rock Punch.
Roast Quail, Currant Jelly.
Lettuce, French Dressing.
Ice-Cream in Forms. Cake. Cheese.
Fruit. Coffee.

Cigars. Liquors.

After sufficient attention had been paid to the wants of the material man the gavel fell heavily upon the table, and President Burchard delivered the following address of welcome:

GENTLEMEN: The Chicago Jeweler's Association at this, its Fourteenth Annual Banquet, extends a hearty welcome to its guests here assembled.

On such occasions, it has been our custom to throw aside the cares and perplexities of business and feast upon the eloquence and wit that flows from the life, lips and hearts of eminent men from the various walks of life, and in continuance of this custom, we present this evening in this magnificent banquet hall a programme that we feel assured will contribute to the enjoyment of all.

I congratulate you, members of the Association, on the prosperity that has so generally gladdened your hearts in the year just closed. You represent a business inferior to none, surpassing in the amount of annual sales many important branches of trade. You have reason for pride also, when you consider that the Chicago Jewelers Association is so thoroughly organized and through its information and collection departments is one of the most useful commercial bodies that exists in this city.

You have with you a number of prominent gentlemen who will address you, and I take great pleasure in handing the gavel over to my friend, Judge George Driggs, who will, in his usual happy manner take charge of the toasts.

Hon. George P. Driggs, Judge of the Cook County Circuit Court was the best toast master that could have been selected. Always witty and bright, he shone at his best and spared none.

Upon assuming his duties as toast master he addressed the banqueters as follows:

MR. PRESIDENT AND GENTLEMEN: It would be difficult for me to express to you how very highly I appreciate the honor of being designated the Mortimer of this occasion (applause); the Brummell is all you can ask for. I fancy that he has set the style in connection with yourselves for banquets henceforth; but that whatever happens in this hall to-night, except perhaps the feeble words of the gentleman now speaking to you, will be followed hereafter as the thing, not only in Chicago, but in the civilized world. (Applause.) I have been listening to the gentleman sitting upon my left to-night (Gov. T. M. Palmer) who seems to be glad to be here, who has criticised somewhat the style of the menu card. I suggested to him that it was an artistic thing. "Why," he says, "That is nothing but bass wood from Michigan; that is what that card is made from." (Laughter and applause.) That was early in the evening, and he recognized the texture of the wood (renewed laughter) and I think he and my friend Burchard have got a bet on hand as to how much it may be furnished per cord hereafter (laughter). But it would be cruel for me to stand between you and the few words from his eloquent lips. No word of mine can add to his fame, no picture that I can make or give to you here now would be as good a photograph as was made of him by Mr. Gage some months ago, when the State's Association assembled in the Palmer House for the purpose of receiving the National Commission. I happened upon that occasion to be one of the reception committee, and I suggested to my friends Mr. Bryan and Mr. Gage that they assemble at some point convenient in the room, and that we would get one or two of the prominent commissioners to stand with them, so that the reception would have some local point. "Well," he said, "get a handsome man." I picked out Senator Palmer (laughter and applause). I think that had something to do with the success afterwards, because as a pacificator when the ladies were in trouble, you know what his success was. The toast to which he had been asked to respond is entitled "The Nation." He suggests that he wants to speak of the World's Fair; I ask him now to take the floor, and speak to that toast instead of the other. (Applause.)

Senator T. M. Palmer in responding to the toast of The Nation, said:

GENTLEMEN OF THE JEWELERS' AND SILVERSMITHS' ASSOCIATION: My friend Burchard reminded me of a little story. He thought I did not recognize him; I did, but I did not want to be too familiar with him at first, and the event justified my care in the matter, because he intimated that he was basswood from Michigan. (Laughter.) I will merely say this, that if Michigan produces so beautiful a fabric as that in bass wood, what will she do in pine or hickory? (Laughter.) But to revert to my story. There was a Confederate friend of mine who married a Catholic lady; I am a Catholic myself. I believe in every man following his

own conscience in matters of religion; I asked him why he had married a Catholic lady. "Well," says he, "I had tried rum and rebellion, and I thought I would try Romanism." (Laughter.) So now I have got Burchard's name thoroughly fixed in my mind. (Laughter.) I was asked to talk here to-night, and I told them I could not talk; I have been out every night this week to dinners and banquets, and I was fairly demoralized; I said all I could do would be merely to ravel out; you give me space enough to ravel out; and they gave me that toast "The Nation." Now, I do not know whether to speak of the nation in connection with your very respectable association or on general principles. My knowledge of jewelry is confined to my Sunday-school lessons. I remember Esther put on her bracelets and necklace, and went before Ahasuerus and knocked Haman out. Then as I came into the room I saw my friend Purple, and that suggested to me another idea in the way of jewelry, for you all remember the couplet

"The Assyrian came down like a wolf on the fold;

His cohorts were gleaming in purple and gold."

I told Purple I owed him one for that. (Laughter.)

Then I remember of the vases and the goblets and all of the vessels of silver and gold that I was told were lugged off from Jerusalem to Babylon, and finally Cyrus or some other good fellow brought them back and built a temple under Rehoboam or some other individual (laughter). I remember something of Cleopatra's jewels that she had on earrings and necklaces at the battle of Actium; but the thing that particularly impressed me was a fellow of the name of Demetrius who was keeping a big silversmith shop in Ephesus at the time St. Paul came along, and St. Paul pitched into the idol business and it hurt Demetrius very much and spoiled his job in that town for a time. (Laughter.) Demetrius was a Greek; you might have a notion that he was a Greek because he was very fly on making money. (Laughter.) He took exception to St. Paul's manœuvring around the idol business and he worked up a mob for a week or two, and made it so hot that St. Paul went off to Macedonia. That brings me down to another thing, Priam's Palace, a little ways from

here, a few thousand years earlier. Schliemann did not find it until three thousand years after it was buried, when they got out these vases and things that were supposed to be in Priam's house. That was about all my knowledge of commercial jewelry until the time I used to flatten my nose looking into the windows of offices looking at Elgin and Waterbury watches. (Laughter.) Gentlemen, possibly these historical things do not impress you as they do me, but I wish to say to you that I am delighted with the fact that you have had a prosperous year. You are the only men I know that will claim a prosperous year. (Laughter.) But then jewelers and silversmiths always did have the inside track; they always did have money to loan in Middle Ages. I think my toast looks toward the nation. Now, I am not going to tell you how broad the United States is, nor how deep it is, nor how high the mountains are, nor how many people there are in it, how high a temperature we go up to in summer, or how low we go in winter. I will say this however, for possibly you have heard some remark in Chicago that this is a great country and Chicago is the hub. Our people however, seem to be ambitious, not only in Chicago but in all parts of the country, to increase the size of their towns and let the country take care of itself. The tendency is undoubtedly to big cities. How long it will continue nobody can tell; but with our present population doubling every twenty-five years, the question that is worrying a great many people is, what are we going to do with them a hundred years from now? In twenty-five years we will have a hundred millions; in fifty years, two hundred and forty millions; in seventy-five; four hundred and eighty millions, in a hundred years, nine hundred and sixty millions, and in a hundred and twenty-five years, nineteen hundred and twenty millions. The question is what is going to become of this vast horde of people when the soil is not sufficient to supply them the necessities of life. It is one of the riddles that I propose to give up, because it don't particularly concern me, but it is worrying a great many people, and I think it is worrying a great many more every ensuing year. There are classes of people in this country that are constantly being worried. I don't speak

of discontented people, discontent you know is the mother of progress. If a man is discontented, he gets up and kicks, and as a rule it takes all his fibre and his muscle. So I say gentlemen, be as discontented as you have a mind to, but don't worry; worry reduces the tissues and takes the tuck out of a man and makes him devilish disagreeable; he can't be a good fellow at the banquet table; he isn't pleasant in his family; he isn't agreeable in church; that is one thing I want to impress upon you. (Laughter.) Old Malthus said—excuse me for using these scientific terms—that while the increase of population went on in a geometrical ratio, the means for prolonging life went on in an arithmetical ratio, and the time was coming when we were going to run against a stump, and that worried Mr. Malthus. It has worried a great many people. I was reminded, in studying this problem of duplication of population, of a little piece I cut out of a paper the other day, which shows that worry is not particularly conducive to the happiness of men or their families.

"The sun's heat will give out in ten million years more,"

And he worried about it;

"It will surely give out then if it doesn't before,"

And he worried about it;

"It would surely give out," so the scientist said,

"In all scientific books that he read,

"And the whole mighty universe then would be dead,"

And he worried about it.

"The earth will become much too small for the race,"

And he worried about it;

"When we'll pay thirty dollars an inch for pure space,"

And he worried about it;

"The earth will be crowded so much without doubt,

That there'll be no room for one's tongue to stick out, And no room for one's thoughts to wander about,"

And he worried about it.

"The Gulf stream will curve, and New England grow torrid,"

And he worried about it;

HAVE YOU TAKEN YOUR INVENTORY?

HAVE YOU REMEMBER —Old gold or silver? If so, —That we pay 4 cents per kt. for gold and highest market price for old silver.

HAVE YOU —On hand a collection of old plated jewelry filings, sweeps, etc., or a lot of old jobs, which have been on hand for years, with no likelihood of being called for.

HAVE YOU —A lot of old style and unsalable jewelry on hand? If so, it would be good policy to dispose of same, convert the proceeds into an article that you would probably turn over several times, besides give your stock a nice, clean appearance.

OUR PLAN —Immediately on receipt of shipment, we will remit by cash or draft (as desired). If our offer should not prove satisfactory, we will return consignment in exactly same condition as received and pay all charges. By this arrangement you are absolutely safe, as it is no sale unless our offer should prove satisfactory, and you run no more chances than if you were disposing of same right over your counter. —Send for our little book giving pointers on testing and buying gold and silver. Mailed free on application.

GOLDSMITH BROS.

Gold and Silver Refiners and Assayers,

63 & 65 WASHINGTON ST., CHICAGO, ILL.

Columbus, Ga., Jan. 10, 1891.

Dear Sirs: Yours of the 7th inst. to hand, containing check for \$29.88. All satisfactory. Accept thanks.
Yours truly, C. M. KINSEL.

Denison, Tex., Jan. 6, 1891.

Goldsmith Bros., Chicago, Ill.
Gents: Your draft of Jan. 3, '91, came to hand this day. Amount very satisfactory. (1812.93).
Very Respectfully, B. W. MERRILL.

Los Angeles, Cal., Jan. 6, 1891.

Messrs Goldsmith Bros., Chicago, Ill.
Gentlemen: Your favor duly to hand, containing check for \$179.94, which is satisfactory to us.
Yours, J. F. GRANAS & CO.

Little Falls, N. Y., Jan. 12, 1891.

Dear Sirs: Your favor of Jan. 9 received, which is satisfactory. Respectfully, ANDERSON & HOUGHTON

Keokuk, Iowa, Jan. 3, 1891.

Gentlemen: Accept thanks for check for \$153.58 in settlement for old silver.
Yours Respy, T. R. J. AYRES & SONS.

Decatur, Ill., Jan. 19, 1891

The check for \$65.75 is all satisfactory.
O. E. CURTIS & BRO

4 Centre Ave., Pittsburgh, Pa.

Gentlemen: \$54.32 received for old gold. Thanks. Am satisfied beyond expectation.
Respectfully, H. SCHEINEMAN.

Milwaukee, Wis., Jan. 23, 1891.

Gents: Your favor of yesterday, inclosing check for \$205.80, to hand, which is very satisfactory.
Yours truly, C. PREUSSER JEWELRY CO.

St. Cloud, Minn., Jan. 2, 1891.

Gents: Your check of \$12.01 is very satisfactory, more than we expected to get. Many thanks.
Respectfully, GEO. R. CLARK & CO.

Moberly, Mo., January 2, 1891.

Goldsmith Bros., Chicago, Ill.
Gents: Your express order for old gold received. Same satisfactory. I get a great deal of old gold and silver, and have sold some in New York and Philadelphia, but have never received what I thought full value until I commenced sending to you. This is my ninth shipment to you.
Respectfully, A. F. SELEN

"Than was ever the climate of southernmost Florida,
And he worried about it;
"The ice crop will be knocked into small smithereens,
And crocodiles block up our mowing machines,
And we'll lose our fine crops of potatoes and beans,"
And he worried about it.
"And in less than ten thousand years there's no
doubt,"
And he worried about it.
"Our supply of lumber and coal will give out,
And he worried about it;
"Just then the Ice Age will return cold and raw,
Frozen men will stand stiff with arms outstretched
in awe,
As if vainly beseeching a general thaw,"
And he worried about it.

His wife took in washing (a dollar a day),
He didn't worry about it;
His daughter sewed shirts the rude grocer to pay,
He didn't worry about it;
While his wife beat her tireless rub-a-dub-dub
On the washboard dum in her old wooden tub,
He sat by the stove and he just let her rub,
He didn't worry about it.

Judge Driggs in introducing Mayor Cregier, who was to respond to the next toast, said:

GENTLEMEN: The next toast upon this programme is entitled "Our City! It was to be responded to by the Mayor; he has just arrived. (Applause.) I suppose he has been searching for some facts, and that he has come here loaded with them. (Laughter.) He needs no further introduction from me, except to announce his presence to you."

Mayor Cregier addressed the assemblage as follows:

MR. PRESIDENT AND GENTLEMEN: I am very much obliged to the President and Toast Master for announcing that I am loaded. (Laughter.) I am perfectly sober. (Laughter.) I suppose he speaks from personal experience, and, therefore, thinks I am loaded. I am not. It is a little cruel, though, after coming up six or eight stairs, no elevators running, that I should be called upon to speak instanter. I should have preferred, Mr. President, that you would have passed me for the moment, and permitted some gentleman here—the gentleman on my left, Senator Palmer—to have spoken on some matter that I might have got a cue, I have seen the fact in print that I am to respond to the "City of Chicago." I am always ready to respond to the City of Chicago, or to the sentiment, however poorly I may do it, whatever I may lack in responding to this marvelous city in words, it is just as fully in my heart as any citizen of this city. (Applause.) I am informed that this is the fourteenth annual gathering of this distinguished body of men. Now, I come here loaded with some facts; I was going to make an attempt to be funny, but I am out of wind. I cannot come to the top of this building and do the subject justice.

(A voice, "Go on.")

Well, I am going on. (Laughter and applause.) First of all I desire to congratulate this body of gentlemen meeting here as they did last year, and coming together to extend a warm hand of friendship and fraternity, not because it must be gratifying to you, gentlemen, for I see a great deal more here than I did a year ago, that your business is progressing. Where else on earth could it progress faster or in a more satisfactory manner than in this great city of Chicago? I take it to be our first in many things, second in a few; first without any doubt probably, in territorial extent. (Laughter.) I have been all over the city trying to gather some facts. It is just twenty-six miles from the southern end of the city to the northern end. While I was up at the northern end of the city I called on a friend of mine at Milwaukee. (Laughter.) It was not but a step; I took supper with him and I have come down since that time here in a cab. The breadth of our city is about ten miles. If you can find any other city on earth that produces that amount of territory under one municipal control and jurisdiction, I should be glad to have some of you gentlemen single it out. In many other things the city of Chicago stands without a peer; in the energy of her citizens, the enter-

prise of her business men and the determination of her community, cosmopolitan though it be, to make it the first city in the world in all things. (Applause.) I take it that there are gentlemen here who will tell you that the city of Chicago stands first in finance. I can remember the time—and I have been here as long as some gentlemen around this table, I have been here nearly forty years—I can recollect the time when it cost eight per cent. to get accommodations in the city of New York. What a wonderful stride we have made since then. We are actually paying a premium to get into the Chicago banks. What a stride in finance, and what a stride in everything else. Gentlemen, you do not all read the public reports that are issued in the city of Chicago, or by the city of Chicago. Let me say to you that since the fire there have been over three hundred million dollars worth of buildings put up in the city. Let me say to you that they cover a lineal frontage of more than three hundred miles. Gentlemen, I congratulate you again, without trespassing upon your time, not prepared as I ought to be to talk to a body of this kind—I again welcome those who are strangers without intruding upon the propriety of those who are residents of Chicago. I hope these banquets will go on from year to year, until even the Auditorium will not be able to hold the jewelers of the city of Chicago. I come here to do myself honor, and to pay my respects to you. I shall be glad to come here every year, whether in office or out of office. (Applause.) Let me say to you that that is an invitation we do not often get, to invite me to come frequently. I am very much obliged to you for this opportunity of coming here. I might talk about Chicago forever, but all I have to say is that it is a marvel to me that this magnificent hall, this magnificent building, only comparatively a year ago, stood on a swamp. Show me the city that is destined to grow as our city is and I will yield the palm. I just want to tell one little incident, and I will sit down, because I know it will please the jewelers. It is only a few weeks ago that I had occasion officially, to take possession of Washington Heights. I went down with some associate officers to take possession of the property, four square miles of recently annexed territory. I rode through backwards and forwards, looking at the magnificent territory, and I assure you, gentlemen, that for some hours I saw nothing but cabbage beds and what they told me were kraut factories. Now that is the territory you want to look at, and I trust that your growth will correspond with the growth of our city. (Applause.)

Judge Driggs, in introducing the next speaker, said:

GENTLEMEN: I have been hearing some good stories here on my left and on my right. I am very sorry that he Mayor was called on so soon that he was not there to hear some of these stories, but for a gentleman who is out of wind I think he did remarkably well. I suggested to the distinguished gentleman whom you have all recognized here this evening that I was sure that this association would be glad to see him on his feet. "Oh," he said, "don't call on me; I am a sort of olive at the banquet." Now, it occurred to me that perhaps we have reached that course in the proceeding; and I have great pleasure in presenting to you Gen. Miles. (Applause.)

Gen. Nelson A. Miles, who, on rising was received with enthusiastic cheers, spoke as follows:

MR. PRESIDENT AND GENTLEMEN: It was with the distinct understanding when I accepted the invitation that I should not be called upon to say anything, and I was assured that that pledge would be faithfully complied with. With that understanding and on these grounds, I accepted the invitation. You see that I have fulfilled my part of the contract, and see how well you have fulfilled yours. I am not ambitious to be called upon to say anything, and as your president has very correctly said, when he asked me a few moments ago if I would say anything, I said "certainly not." "Well," he said, "I am going to call upon you and you will have to say something." "Well," I said, "I will have to be in this array of eloquence, in this list of orators, very much as the olive appears on your table; I will appear just about that end, and I shall not attempt to do more. I

am gratified, however, to be present on this occasion, and to meet the gentlemen of this association, as I see before me so much intelligence, and I have realized the fact that you are engaged in the profession that has given so much pleasure to mankind. It is the gold workers and silver workers and bronze workers that have perpetuated the civilization and the intelligence and the art of mankind. Looking back through the ages we find that the civilization or the barbarism of a race is indicated by what they have left in works of art, in pottery, gold and silver and in bronze. Judging from the appearance of the gentlemen that I see before me, you are stepping on gentlemen, and your progress will be forward and not backward; and here in our own country—a country susceptible of magnificent development, great wealth and great progress—here in this magnificent city, as your mayor has properly said and illustrated, that it has no peer and no parallel, I realize the fact that by your enterprise, your fortitude, your courage and your skill, the art and the business that you are engaged in will not retrograde, but it will go on. I have in my own experience, passing over the valleys and mountains of the great West, seen their mountains of silver and gold that will in time be drawn from these mountains and made useful. I realize also that the enterprise of the American people will utilize still another substance, that is known as the petrified wood of the mountains of the West. As Gov. Palmer has told us how basswood grows in Michigan, with all that beautiful engravings on it (laughter), I am reminded also that the skill of the jeweler has wrought beautiful works of art in these materials of the petrified forests of the West. I am reminded of a little story and as you are so enterprising and so industrious, I have no doubt that you will utilize not only the petrified forests that one of the American fur companies discovered, but you will also utilize what Jim Bridger discovered in the North. Some years ago the American Fur Company sent out trappers and miners all over the eastern country; they used to go out and gather in their furs, and in the winter they met at some central point and exchanged and bartered their furs for what they wanted, and they occasionally would swap lives, and amuse themselves, and they would remain there during the winter and go out again in the spring. One winter one of their trappers had gone over the mountains to the southwest and had gone over to Arkansas and the head waters of the Colorado, and had discovered what is now known as the petrified forest of Northern Arizona. He came back and told this story, that he had discovered there this wonderful forest of petrified wood. Jim Bridger who had really gone North the same season had discovered that basin which is now known as Yellowstone Park. He had actually discovered the geysers and mammoth springs; he had discovered that the geysers threw up a stream of boiling hot water and as it descended the sprays crystallized upon the trees so that they looked like snow-covered trees. He said this petrified forest down in the southwest amounted to nothing; that he had gone further North and he had discovered there not only a petrified forest, but he had found that on these trees there were petrified birds singing petrified songs. (Laughter and applause.) Mr. President, I have no doubt that in time, that the genius and enterprising jewelers of Chicago will not only utilize the petrified forests of Arizona and the petrified forests of Montana, but that these petrified birds will be made into beautiful works of art and ornament. (Applause.)

Mr. J. S. Runnells responded to the next toast, "Gold and Gilt." He said:

GENTLEMEN OF THE JEWELERS' ASSOCIATION: The toast master might have said, with a great deal of propriety, that my toast was not to follow that of the distinguished soldier who has just spoken, but that his speech was to be a substitute for mine. That is what he might have said with a great deal of gratification to me. Gentlemen of the Association, I wish to add my words of congratulation to those of the gentlemen who have preceded me upon the success of your association, and on this, your fourteenth annual banquet. I have attended many banquets in this and many other places but I have rarely seen a more beautiful board, and I have never seen one surrounded by brighter and more intelligent looking men; and from your appearance I should judge that the prosperity which will come to you will not be of gilt but of gold. I remember that Wash-

1891.

THE MIDDLETOWN PLATE CO.

MIDDLETOWN, CONN.

MANUFACTURERS OF

Superior Silver Plated Ware.

WE SHALL offer for the ensuing year a largely increased variety of STAPLE and FANCY GOODS. We solicit the attention of the trade.

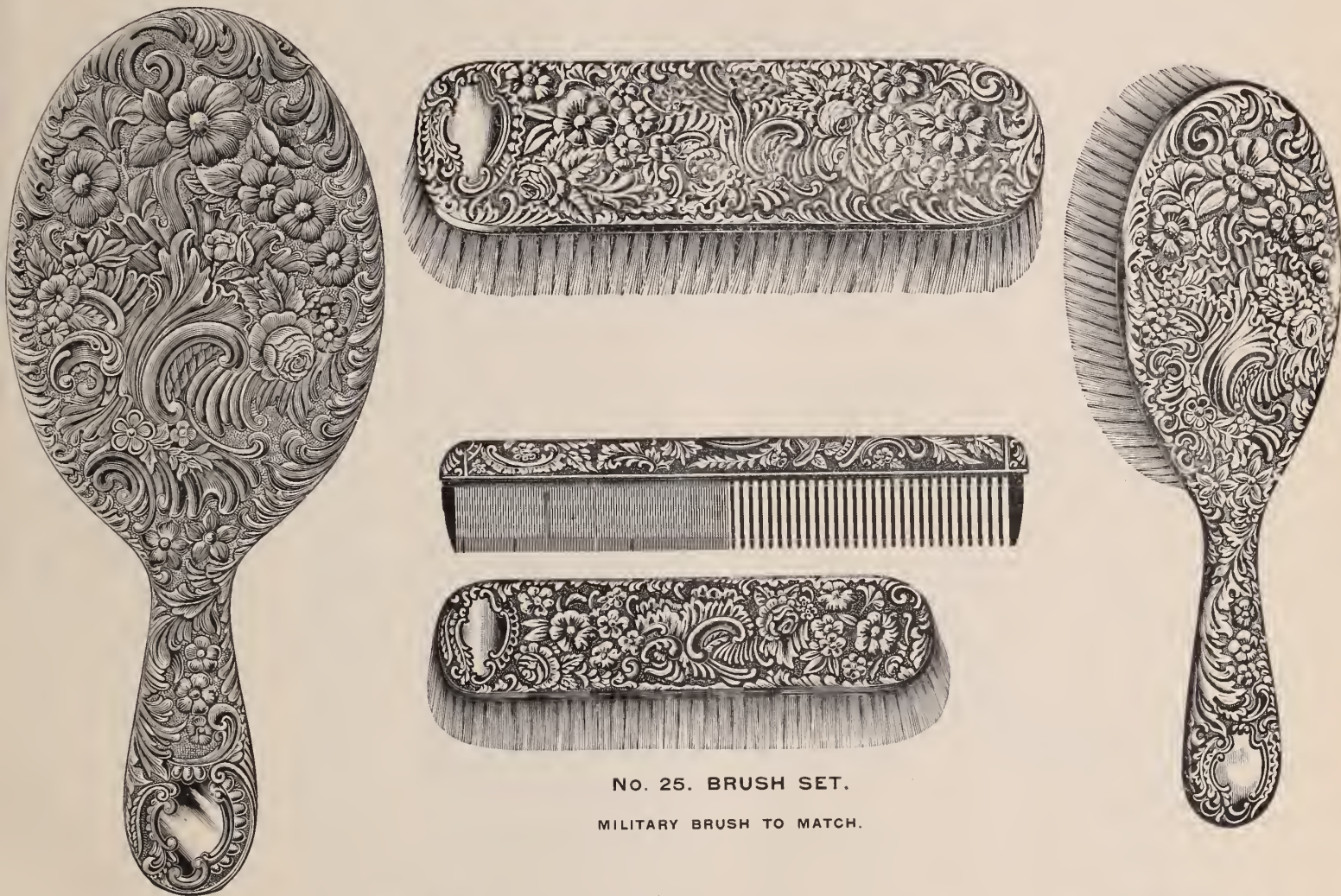

NO. 25. BRUSH SET.

MILITARY BRUSH TO MATCH.

THE MIDDLETOWN PLATE CO.

SALESROOMS: { 22 John St., New York, 113 to 115 State St., Chicago, Ill.,
118 to 120 Sutter St., San Francisco, Cal.

ington Irving once told a story of Sir Walter Scott, which was that the Seer had returned home after a journey and was going on to tell his family a story about a friend of theirs, the Laird of McNab, and by the way he said: "He is dead and gone." "Why, my dear Mr. Scott," said his wife, "you don't mean to say McNab is dead, do you?" "Both," he said, "'For if he is not dead they have done him a great injustice, for they have buried him.'" (Laughter.) Gentlemen, I shall do myself great injustice if I attempt on this occasion and in this presence and after this magnificent hospitality to say much about the difference between gilt and gold. Perhaps I had better dispose of the subject entirely as did the witty Sheridan of England in a remark he once made to his son. Young Sheridan was telling his father that he had gone down a mine at a great expense of comfort and convenience to himself, not that he cared to be seen down there, but he just wanted to say that he had been down a mine. "Then," said Sheridan, "why didn't you say so and not go down the mine at all." (Laughter.) Gentlemen, gilt and gold representing opposing ideas that are struggling all about us for mastery. It is not simply on your shelves and in your vaults that these two are seen side by side; it is not only in articles of commerce that the real and the false are mistaken one for the other. We see on the street, in clubs, and in private gatherings, we see in places where laws are made, where public justice is dispensed, where the gospel is preached, we see our idols are very much like other idols, sometimes of good metal, but often of base metal. I am inclined to think the American people, to quote from Mr. Barnum, delight generally in humbug. I do not say this in any partisan sense, but it is true, as Mr. Barnum said, that there are indications all about us that we are too often inclined to prefer the gilt to the gold. When, for instance, a great congressional district in a great State, representing one hundred and fifty thousand people, will select a man to represent it in the last Congress, chiefly because he boasted that he never wore socks; when a man is elected to the important position of a judge, who is compelled to study law after his election, because the propriety of studying law before had never occurred to him; when an organization with sufficient power to carry an election for United States Senator, declares that the object of that organization is to turn the United States Senate into a money-lending concern; then I think that you all, whether democrats or republicans, or whatever be your political faith, will agree with me that the political sense of this country is not only not gold, but it is gilt and a very bad specimen of that. (Applause.) Arch-Bishop Whately, told a story of a flourishing banker who bequeathed his business to his son, together with a very large and very strong iron chest, securely locked, and supposed to be full of gold. Calling his son to him some time afterwards, he said: "To tell you the truth the chest is empty, but you keep the secret and the secret will keep you." To that spirit gentlemen, you may trace a very large part of the evils of our business and professional and political life. To that spirit you owe the fact that men are among you who will pray with their lips while they are plundering with their hands; to that spirit you owe the fact that men

are found in your midst who will play off, sometimes successfully the triples part of hypocrite, thief and banker. To that spirit you owe the fact that the records of your criminal courts, as my friend the toast master will confess that the dockets of these courts are crowded to overflowing with cases involving breaches of trust, betrayals of business confidence, and loss of business character. To that spirit you owe the fact that you hear complaints coming up from all over this country about watered stock, and the wails of people who have been sufferers from that peculiar system of financeering so much in vogue in this country, by which the investor is deluded into the belief that he is getting something, when he gets nothing but a beautiful chromo. How true it is that we often hear.

'Silver and gold will often pass.

Sometimes for gilt and sometimes for brass.'

"But turn the other side of the picture. It is pleasant to turn away from the consideration of mere gilt to the consideration of gold. The earth is full of precious metal; life is filled, if we will but look to see with those things which the heart recognizes as true and genuine. It is a great thing to win the battle; it is a great thing to be able to write a little poem like the Iliad. It is a great thing to be able to paint a great picture like the Transfiguration. But greater than all these things is the development of a well rounded and symmetrical character. You remember that Humboldt said that all things, government, religion, property and everything else, are but the scaffolding to build up a man. Above all things that we admire, above all things that the world admires, is the man who, without pretense and without affectation, with the consciousness of the rectitude of his purpose, with his intent clearly before him and the consciousness of his fixedness of purpose, goes about his chosen work in a manful way and clears away all the difficulties before him. Such men are the gold of the world; they are the heroes we love; such men as these elevate society and purify it; they purify your political methods; they purify society against self-interest, and their lives are an everlasting protest against meanness, and fraud and dishonor. Upon their strong arms rests the security of society, the hope of virtue and the preservation of good government" (Applause.)

Judge Driggs, in introducing the next speaker, said:

"GENTLEMEN: Our friend, Gen. Miles, has been playing a very good part here to-night, because he has been sitting between the gentleman who is going to respond to the coming toast and myself, and I have listened to many of the words that passed between them, and I find that a good deal of their discussion this evening has been with respect to the advantage art. In connection with the story which the General told, I think that Mr. Hillis made some objection to it. I do not want this difficulty to proceed any further. I make the public announcement now, so that no further difficulty shall take place, simply warning Mr. Hillis before I called him to his feet, that we have had enough of that, and the General has been used to have his own way so long. I take pleasure in introducing the Rev. Mr. Hillis, who will speak on the subject of Art."

The Rev. Newell Dwight Hillis, responded as follows:

"MR. CHAIRMAN: I congratulate myself, gentlemen, that in this beautiful hall so superb in all its appointments, around this lavish table, so finely decorated, that I am to say a few words in the interest of the beautiful. Our age has declared very emphatically in favor of the useful, as exemplified in the trades; and orators have again and again said something in praise of the farmer and the engineer, but never can we praise enough those men who are toilers in iron, wood and stone in the fashioning of this external world, and yet commending to the highest utility which has given to us this goodly store of creature comforts, we are assembled to-night in the interest and in the name of the beautiful to commend these gentlemen who, when they have discerned that society has gained all useful things, press on to adorn the home and decorate and embellish the person, to search all the lands over for precious metals and shining gems with which to bring a pleasure to the home and to the person. I give to you to-night this simple sentiment: The moral functions of the silversmith's art: in that o'er all useful things they seek to cast the garb of beauty. Now, I take it, gentlemen, that your art as to its genius has this certain sign and seal of divine approval—in that God whenever he hath made a thing perfect casts over it the garb of beauty and of radiant loveliness. All things in their low stages are rude and ugly. Not until the divine comes forth and the fruit hangs pendant do things evince for what they are made. Not until the peach has come to bloom do we know that it has come to ripeness. So that we protest that your function of duty stands for the period of ripeness in man, for perfection, for the full plans of development. The vigor of strength, the maiden's bloom on her cheek is not frosted over, but is healthy to the innermost material, never neering on the outside of the pearl or diamond, but the innermost jewel glows and gleams like a star. All through this world soundness at the center makes the beauty of the outside; so that in all your work casting beauty over utensils, over the mantle pieces, over the sanctity of the altar, sprinkling beauty down upon the board, you become the ministers to the highest functions of mankind in this simple service of food and drink, and you bear away the special sign and seal of God. So that whenever you bring to your aid all resources of metal, of fine works of wood, of stone, of jewels, of things that sparkle everywhere, you are walking in strict analogy with the divine thought and the divine arrangement. So that no misconception could be utterly more false or artificial than this: that your art is superficial, that it is not useful, that it is meant simply for the decoration of the body, when it satisfies the eye and the imagination, and the taste, cultures conscience, adorns the whole man. That great God who made this world, which is but one bud, plucked from the bough of beauty, who made that milky way to be a bracelet, in which He puts the countless stars of shining brilliance, was the first great Silversmith, and the divine Teacher with respect to jewelry. I take it gentlemen, that on another side, that you have become the helpers of the diffusion of the beautiful

AN UNUSUAL BARGAIN.

We have just completed a purchase of WILSON'S SPECTACLES, which the Manufacturers assure us is the largest purchase of these particular numbers ever made in the United States. Therein lies the reason that we can submit this remarkable offer:

No. 184, steel-tempered plano-convex lenses, open joint, end pieces held together by steel pin with screw cut on end.

In Blue frames, 5 b dozen, net; 6 s e gross, net (30 days)

" " " " " " ; t y e y " " (30 days)

(We never advertise prices in plain figures on goods bought by the Jeweler to be sold again, believing him entitled to protection against the public's knowledge of cost price. Send for Cipher Key to our advertising Price Mark.)

The above gross price is only \$4.00 more than the price of the wretched German Iron Spectacles, and 20 per cent. below the lowest figure ever offered on American Spectacles. It is actually lower than the goods have ever been sold to the bulk of the Jobbing trade.

No. 155, fine steel, periscopic convex lenses, reinforced nose piece. This is the well-known first-class WILSON SPECTACLE, and the following prices will amaze regular buyers.

In Blue frames, 1 t y dozen, net; 1 i n i e gross, net (30 days)

" " " " " " ; i e e y " " (30 days)

To secure the gross price a full gross must be taken of either No. 184 or No. 155, but the gross may be assorted between Blue and Nickel-Plated. A special discount of 2 per cent. allowed on purchases of 5 gross, and not more than 10 gross of these two numbers will be sold to any one buyer, as we shall limit the quantity to be sold at these prices to 250 gross. Orders filled in rotation as received.

We solicit inquiry as to our prices on the entire line of Wilson's Spectacles. We issue a very handsome illustrated catalogue of the line, which we send to regular jewelers only, on request.

Boyman & Musser, Importers and Jobbers, Watches, Chains, Spectacles, Tools and Materials, Lancaster, Pa.

throughout all society, and that you stand for one of the noblest occupations that society needs.

"In other times and in other ages art was centralized, considering that in the days of Pericles all artistic genius of goldsmith or silversmith was subsidized in the interest of the Parthenon, considering that in the days of Raphael and Michael Angelo all the genius of men who stood for your craft was subsidized, and reserved in the interest of the temple and the cathedral. The gods lived in palaces and the people lived in hovels. In the days of Phidias the streets outside differed from those of which Mayor Cregier boasts. The street hadn't a sidewalk, and when the fine women that lived on the Athenian Prairia avenue got ready to heave their dishwater out of the front room window they cried "Beware" to every passer by. Socrates went to a great banquet like this in his stocking-feet, and Plato tells us that having stayed there all night and drank everybody else under the table, that he remained talking philosophy until the morning twilight, unchanged in any sense; except this, that he had let out the strap that held up his pantaloons to the last hole. (Laughter and applause.) But in your day you have centralized and diffused all art. You have sent it into the home; you have adorned the person; scattered it around about the board, and placed it on the mantel piece. You have sent it out everywhere; you have become one of the noblest teachers on the side of truth and civilization. It is imagination that has carried civilization along, and I hold with Longfellow that that poor savage Indian who was pleased by one single ornament was lifted up in his surroundings to meet that. Thus it stands for you to send out countless simple gifts into peasants' homes, who shall be lifted up by that single gift; and so my brain must stand on this level, my child's brain and imagination must come up to that, my home must mount to meet that, until at length you have transformed and transfigured the millions in our land. I take it that it may be said you have wrought most wonderful for the good of the people of our land, in that working for the beautiful, for the taste, for the genius that adorns this board, and this

room, you have stood as a standing protest against this outer external material sordidizing life of which Mr. Runnells has spoken. Consider that we stand here, in our age, needing to remember that instead of tools and machines there is something called beauty and taste that distances them all. We need to remember sometimes that a poem can do the work on the way of breaking up the fallow ground that a plow cannot. We need to remember sometimes that there is silver lining in sorrow's cloud, that yields a larger money return than all gold and shining ore. Sometimes we need to remember again that a tiny bit of tissue paper on which is written that simple word duty, outweighs huge rocks. Sometimes we need to remember that in an age tools, machinery, paving stones, cars and telegraphs, after all the men who stand for the beautiful, are exerting a noble function, and stand up against that material age of which this gentleman has spoken so wonderfully. This material tendency has gone to such lengths that out in Kansas, as the gentleman hints, they think that men who can raise great pumpkins surpass men who can evolve philosophies and poems. Our breed of Solons seemed to think that 78 cents is a dollar, that three pecks can by law be made to equal a hushel, that 30 inches equal a yard. They seem not to know that a paper dollar that can't lift up its head and swear, 'I know that my Redeemer liveth down at Washington' is a fraud and a delusion. That is the result of this great materialistic tendency, that puts its emphasis on things instead of on taste and beauty. We want to honor the Jewelers' Association with all its love for taste and beauty in respect to this thing that they have taught us, this noble idea that out of the ugliest things of earth can be brought things that are wonderfully beautiful. I remember only this, gentlemen, that you bring every means from all the outside things that make for the adornment of everything and so we get the pledge of that strange power that can lift up manhood, that can give us a soldierly life, teach us this—that we are all jewelers of character; beginning upon that which is given by heredity and environment. When the temptation has graven us with her tool, it calls out from us the cry 'Rise up Sir Knight,

beautiful in everything that makes for the adornment of thought and that nobler beauty that is within the man.'" (Applause.)

The Toast Master introduced the next speaker, County Attorney Frank S Walker, in the following language:

"GENTLEMEN: I regret to announce that Mr. William J. Hynes, who was to respond to the next toast, 'Jewels,' has been taken ill and could not attend. In the same breath it gives me great pleasure to say that Mr. Frank Walker, the County Attorney of this County, has kindly consented to respond to this toast, and I will now present him."

RESPONSE BY FRANK S. WALKER, ESQ.

"MR. TOAST MASTER, AND GENTLEMEN OF THE CHICAGO JEWELERS' ASSOCIATION: The kindness of this consent is indeed a misery to me (Laughter.) But I received such urgent solicitations from Mr. Hynes himself, accompanied by the request of your committee, that I dare not deny the charity to the one nor the satisfaction of the sight of my agony to the other. (Renewed laughter.) And hence it is that I have agreed, not with any opportunity of preparation to assume the functions of the toast deliverer upon the question of jewels, a subject which, next to the subject of Art, has enlisted the historian of all ages and shown more than any other the development and the civilization of the people. Without any opportunity of investigating the beginning or origin of jewels, except as one's memory can call to mind the reading of his hours of study, I am still frank to say this: that the object for the building of the great monuments of the world was to not only perpetuate the history of the kings, the birth and heredity of families, but to perpetuate the development and the history of nations; and side by side with those monuments, or in the monuments themselves, of the most ancient nations, the tombs of the dead of thousands and thousands of years, are found the magnificent jewelry of past ages long dead in history, to show that before the Pyramids were built, a civilization existed that

A. J. LOGAN

Manufacturer of HAIR SPRINGS and HAIR SPRING WIRE, Bracelet Springs and Small Springs of every description; also Watchmakers' Tools.

21 CRESCENT ST.,

WALTHAM, MASS.

UNIVERSAL BEAT BLOCK.
For English, Swiss or American Watches.
Price, 75 Cents.

VIBRATORS made to order at \$5.00 each.

Single Hair Springs vibrated to balance, 25c.;
Sets of Breguet Tweezers (4 in set) at \$5.00 per set.

NON-MAGNETIC TWEEZERS. Price, 10 Cents.

COUNTERSINKS AND BURNISHERS. Price, \$1.40.

Vibrated and Colletted, 35c.; put in the Watch and brought to time, 75c.;

GEM SCREW DRIVER Five Sizes, \$1.25 per Set
Colored Heads—designating size of blade.

JAW AND DEPTH GAUGE.
Patented Aug. 21, 1883.
.001 of a centimeter or .001 of an inch, \$14.00.
.01 of a centimeter or .01 of an inch, \$8.00.

SEND FOR ILLUSTRATED CATALOGUE.

manufactured jewels. I know this from past reading—that there is no one thing that develops or enlarges the character of a people more than the jewels of that people; that there is nothing that surrounds the national life and that shows the development and character of the nation more than the handicraft of the people. And in many of those ancient monuments where the record of the people themselves is forever dead, that is to say, the old thought lives perpetuated; that while the individual dies, the species, or the great bulk and race of mankind moves on, and in the development shown in the history of the past ages, in the tombs of the nations themselves can be discovered the growth and development of the civilization at least in that art that is hardly surpassed by the art of to-day.

This subject of jewels, if alone it had reference to the craft of this association, might teach a great lesson to mankind from that source alone. But I consider that one can properly address himself upon this subject to the jewels of a people. I consider that the jewels of a people consist of the sturdy, honest, upright, unselfish man; not the individual who seeks selfishly for the development of his own fortune to the detriment of the rest of mankind, but that one man who propounding some thought or doing some act that leads to the advancement of the entire people—that one man in my opinion forms one of the different stages in the jewels of a people. In our own stage we would begin with the father of the country himself, and follow down through a long line of statesmen, poets, philosophers, thinkers and artists, until we came to the very hour itself and viewed this magnificent jewel in which we now sit together, perhaps the greatest architectural adornment in the line of magnificent display in the history of any city and any country and almost any age. This is one of the jewels of the people. And so we can know this as we close the toast on this subject that not only does the artist in the adornment of the present as he decorates utility with art form a link in the progress and history of the nation, but that the great jewels of the nation are those men and those individuals who, in the line of their own genius, develop, add to and increase the

common knowledge, the common benefits and the common culture of mankind.

The toast-master introduced the next speaker, Hon. T. B. Bryan, who was to respond to the toast, "The World's Fair," with the following remarks:

I know you will be pleased to know that Mr. Bryan has consented to respond to a toast, which rises, I am sure, to the lips of every gentleman present, the greatest project now known to the civilized world, the World's Fair.

REMARKS OF HON. T. B. BRYAN.

MR. PRESIDENT:—I had almost said, in addressing a judicial presiding officer, "Your Honor and Gentlemen of the Jury;" When the promise was exacted of me by a call last evening by your distinguished president that I should be present this evening, I can only confirm and reiterate what Gen. Miles said, that it was upon the whole assurance that under no circumstances should I be called upon for a speech, and that I should take a humble seat in the rear of the hall so that I should not be among the aspirants for oratory this evening. I confess, however, since I came here, the proposition of the distinguished toast-master has sufficed to make me the martyr of the occasion, and to say a word or two upon this subject so dear to all our hearts. I had wished, however, that our distinguished president and the chief executor of the national commission, had given us the benefit of his eloquence on this great topic. And as I listened to him speaking I was reminded of Dryden's tale of the Lover's Serenade. A man whose voice was not unlike mine, but who wanted to serenade his beloved at night, induced a very fine singer to get behind him in the dark. The lover sang apparently with his mouth wide open, and the lady love was undoubtedly perfectly carried away by the melody of his voice, until forgetting to shut his mouth when the other ceased to sing, the trick was betrayed. (Great laughter.) If I could only have had the distinguished gentleman to do my speaking you all would have profited

amazingly. I took notes, however, as he was talking, and one of the first things he said was—and very well said—that about worry. I remember Dr. Abernethy said upon that subject, and that was that the two great factors of human misery was too much stuffing and too much fretting, a remark which was emphasized most eloquently by the remarks of the gentleman: Then I observed his remarks too about too much centralization and flocking in from the country to our great cities, and he began to tell us in figures until I began to be bewildered myself. Indeed, it reminded me of a story I believe we talked about, a story of a young girl who was very brilliant in everything else except figures, and she was told to learn the multiplication table. She set to work diligently to accomplish that task, and before she got very far she found that she could not multiply. She tried again and again until finally stepping to her teacher she said, "Oh, I wish I were an Australian rabbit." "Great heavens, my child, why? What put that idea into your mind?" "Why, it was only last night I read that they multiplied rapidly." (Laughter.)

Somebody told us that some one went without socks—and I have no doubt he showed his cloven foot at that time, and then I heard from the eloquent gentleman who sat to my right—I hope he has not disappeared for if he has I cannot say of him as I did of Chauncey Depew on one occasion, that whenever he opened his mouth he opened a casket rich in jewels of rhetoric and wit, and they have been calling me "Casket" ever since. (Laughter.)

I heard over here such a tribute to manhood reiterated by a gentleman who followed, that it made the blood glow in my veins, that tribute to manhood which I wish were impressed upon the mind and heart of every man young and old in the hearing of their voices. That is the idea that the jewels of this land consist of those men who are men, if not by birthright, men by the exercise of the highest faculties of human nature. They shine aloft with imperishable lustre in the brightest diadem of humanity. That is the jewel which

(Continued on Page 57.)

ROGERS, SMITH & CO.

BEST QUALITY

GOLD AND SILVER PLATE.

Union Square, New York. 

 Meriden, Conn.

Listening to the Beating of a Watch.

Many defects which may be discovered by these means—Some suggestions as to how to correct them.

BEING a practical, rather than a theoretical watchmaker, it appears to me to be indispensable to every complete watchmaker to know how to listen to a watch and to be able to diagnose and correct its defects on the information obtained in this manner.

A number of times already have questions of this kind been put to me: "What produces the noise in watches?" To what causes is it due, and how must it be corrected? The subject is really a hard one for the outsider to understand.

Concerning the better-grade watch, however, one that is required to keep precise time, its rate cannot be guaranteed before having passed a minute examination by the well trained ear of the watchmaker, who by this means might discover a number of defects which hide themselves from ocular inspection. Let me be well understood. It is not the difference of works to which importance is to be attached, but whether the going is free and betrays neither frictions nor imperfections of any kind. These noises, these defects, which the ear perceives, are generally only found in the organs of the escapement, and the balance in particular. The sound itself can never be relied on altogether because it varies from one watch to another, and is due to different circumstances which are not always injurious. For instance, the going of a watch with a cut balance will always be more sonorous than another with one not cut. Another one may have a very nice beat, and still be full of friction—to such an extent, in fact, as almost to cause the watch to stop.

With watches of precision, in which each part has been executed with special care and without regard to economy, a good rate is generally obtained. Nevertheless, in spite of their superiority the microphone is often employed as auxiliary, in order to more clearly distinguish any injurious frictions, which may produce changes of rate in the different positions the microphone, being to the ear what the magnifying glass is to the eye.

The watchmaker can in a few seconds listen to a watch without going into extensive preparations for doing it, and without giving himself an air as if he were to perform a piece of prestidigitation or undertake a mysterious work. Some imagine that they can hear better by inclining the head to one side, closing the eyes, stopping up one ear, or going into a course of gymnastics not at all graceful. They balance their body to the right or left, in order to listen to the watch in those positions, and finally, they believe that they hear noises which only exist in their imagination. At other times they pay no attention to the sound of a rate which pleases them, but has no other merits.

The watchmaker, as well as the great majority of mankind, has generally one ear that

has more subtle hearing than the other, and he is therefore at liberty to choose which of the two he wishes. By constantly using the better ear, and thereby training it, it will finally become so sharp of hearing that it will be a very useful organ to him. It will tell him of faults in the rate of the watch which his eye failed to discover. In order to avoid any loss of time it is advisable to subject the watch to this auricular inspection before being put into the case. Let him place the watch on the movement ring, or into a paper box or movement box—the article employed must be of such a nature that he can hold the watch to the ear.

What, now, are the defects, the frictions, which the ear detects?

It is easy to believe that the greater part of these noises are due to the balance. Let us try to enumerate the different ailments which this part may have in a—let us say, anchor watch.

First, it will be admitted that at present the quality as well as the temper of the balance axes are not all they should be. It is even rare to find any possessing the necessary hardness.*

This circumstance often causes great inconveniences and seriously places in jeopardy the good rate of a watch because it is difficult to have a suitable pivot if it is left too soft or if its steel is of bad quality.

The pivots which are not in good order cause hurtful frictions. In order to find out these little details, the magnifier is indispensable. The pivot ends often have burr, which may be produced in two different ways, either when turning the pivot or when sloping its end. They may in either case cause friction that can be heard distinctly and which should be removed.

(To be continued.)

Phosphorescence of Diamonds.

MR. GEORGE F. KUNZ, the diamond expert, has written a very able and interesting article on the phosphorescence of diamonds, which has been published in a recent Sunday paper. In it he gives the results of a number of interesting experiments with the most precious of stones as well as a collation of the experiments of many gemologists who have written on the subject. It contains much information.

Appropos of Mr. Kunz and his writings, an article of his "Taste in Diamonds," has been going the rounds of the newspaper press with the head "Paste" instead of "Taste." It is amusing to notice how frequently this error has been repeated.

COLUMBUS, Miss., Jan. 26, 1891.

It is with pleasure we enclose a post office order to secure your valuable CIRCULAR for another year. We assure you we could no more do without it than a captain at sea without a compass. The fact is, we look for it as eagerly as a school boy does for the *Youths' Companion*.
BUDER BROTHERS.

* The author refers to Swiss pivots.

Our Banks Yearly Showing.

THE following are the last statements of the three New York city banks in which a number of prominent members of the trade are directors, and with which many local houses are in account:

Resources.

MERCANTILE NATIONAL BANK, DECEMBER 19.

Resources.

Loans and Discounts.....	\$7,540,606.25
Overdrafts.....	10,68
U. S. Bonds to secure circulation.....	50,000.00
Other Stocks and Bonds.....	14,000.00
Real Estate, Banking House.....	200,000.00
Clearing House Loan Certificates.....	50,000.00
Cash.....	3,734,993.47
	<hr/>
	\$11,588,710.40

Liabilities.

Capital Stock paid in.....	\$1,000,000.00
Surplus Fund.....	750,000.00
Undivided Profits, net.....	203,252.00
National Bank Notes outstanding.....	44,000.00
Clearing House Loan Certificates.....	770,000.00
Deposits.....	8,820,458.40
	<hr/>
	\$11,588,710.40

CHATHAM NATIONAL BANK, JANUARY 1.

Loans and Discounts.....	\$5,418,939.16
U. S. Bonds, 4½ per cent. par value.....	50,000.00
Due from Banks and Bankers.....	736,214.21
Cash.....	2,199,218.34
	<hr/>
	8,404,372.21

Liabilities.

Capital Stock.....	\$450,000.00
Surplus.....	700,000.00
Undivided Profits.....	34,744.54
Circulation.....	45,000.00
Deposits.....	7,174,627.67
	<hr/>
	8,404,372.21

The above shows an increase of deposits over the previous year of \$300,000, and an increase of surplus of \$100,000.

NATIONAL BANK OF DEPOSITS JANUARY 10.

Resources.

Time Loans with Collaterals.....	\$139,824.75
Bills Discounted.....	330,174.81
United States Bonds.....	50,000.00
Premium on same.....	9,000.00
Furniture and Fixtures.....	2,000.00
Expenses Paid.....	142.40
Cash.....	819,971.93
	<hr/>
	\$1,351,113.96

Liabilities.

Capital.....	\$300,000.00
Profits.....	66,603.05
Deposits.....	937,957.36
Circulation.....	45,000.00
Cashier's checks outstanding.....	1,553.55
	<hr/>
	\$1,351,113.96

Loss Adjusted.

WATERTOWN, N. Y.—The loss on the stock of Silas L. George, jeweler, has been adjusted on a basis entirely satisfactory to Mr. George and the insurance companies, and within half an hour after the agreement had been reached the draft covering the amount was in Mr. George's hands. The store has been re-opened and the stock is being re-arranged,

★ ROGERS & BRO. A-1.

OLDEST BRAND MADE.

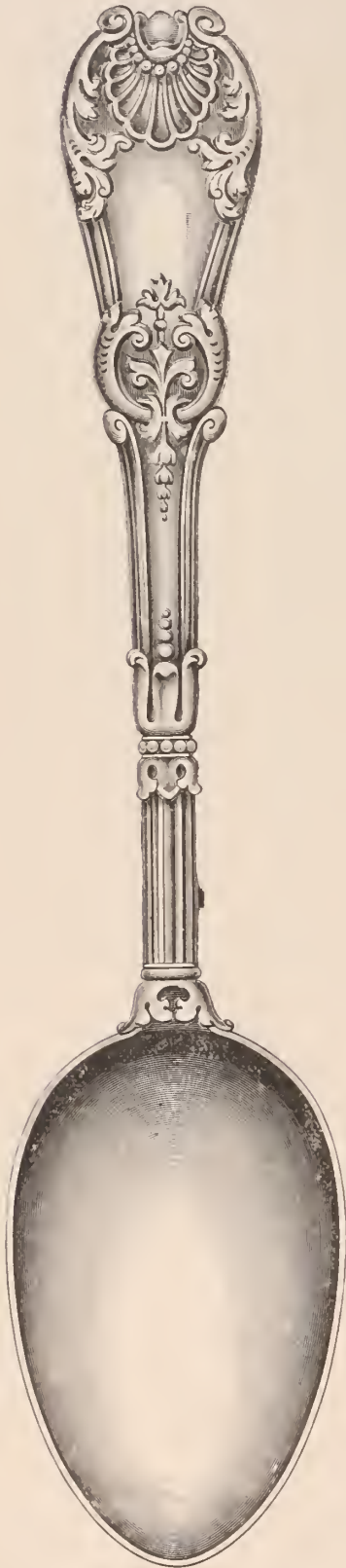

NAME COPYRIGHT GRANTED.

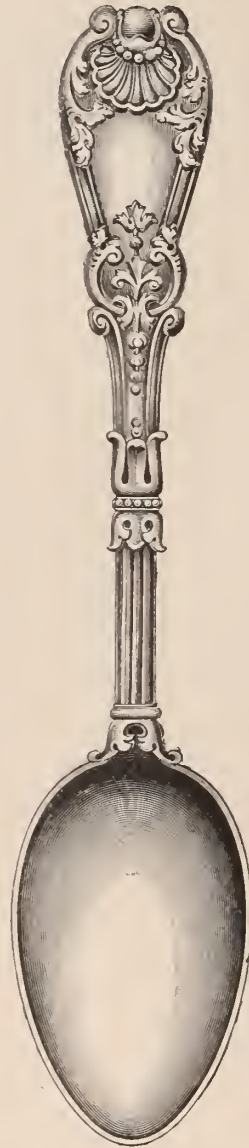

DESIGN PATENTED.

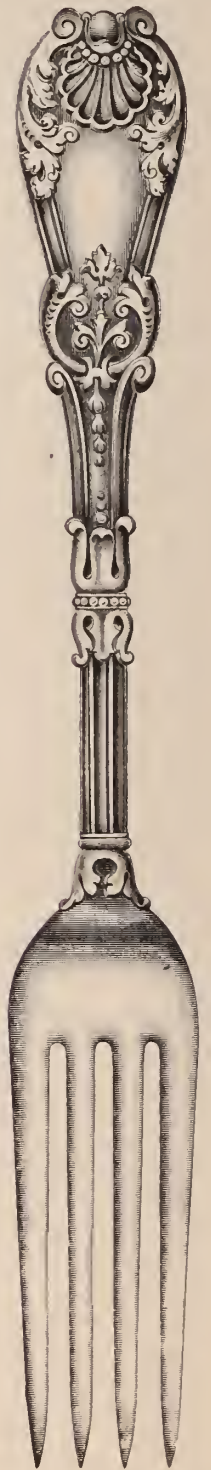

THE "TUXEDO."

WE INVITE attention to our NEW PAT-
TERN, illustrated here, which for
massive richness, grace of outline and
general artistic excellence is unsurpassed,
and which we feel assured will meet with
the approval of the trade.

ROGERS & BROTHER, WATERBURY, CONN.

Manufacturers of the Highest Grade Electro Silver Plate,
16 CORTLANDT STREET, NEW YORK.

Coloring Gold.

GOLD ALLOYS, especially those containing copper, acquire an unseemly brown, or brownish black color, due to the oxide of copper and produced by repeated heatings during their manufacture. To remove this they are boiled or pickled in diluted sulphuric or hydrochloric acid, according to the color they are to have. If we have an alloy containing only gold and copper, either sulphuric or hydrochloric acid is employed; for gold is not attacked by either of them, while the oxide of copper dissolves so easily that after the pickling the articles have the color of pure gold, because the surface is covered with a thin filling of gold. If the alloy consists solely of gold and silver the liquid employed is nitric acid and the articles are left in it a very short time. The acid dissolves a very small portion of silver and the articles acquire the color of gold. If the alloy contains both copper and silver besides the gold, the method of pickling can be varied to suit the color it is desired to give. If, for instance, it is put into sulphuric acid, the copper alone is dissolved and the color obtained is that of an alloy of gold and silver; for the surface consists of both. If nitric acid were used both copper and silver would be dissolved. In this case the color obtained would be that of pure gold. The articles are heated and allowed to cool again before boiling. The object of the heating is to destroy any grease or dust that may adhere. If they are soldered with soft solder, they cannot, of course, be heated, and must be cleansed from grease and dust by first putting them in a strong lye, then washing them with water and putting them in the acid. The acids are used dilute, usually in the proportion of one part of concentrated acid to forty parts of water. The articles are laid side by side in a porcelain or earthenware dish, and the dilute acid is poured over them. From time to time one is taken out to see if it is yellow enough. When the proper color has been obtained they are washed in clean water and dried.

While this pickling is merely to bring out the color of the gold, the coloring of gold has for its object the imparting to inferior goods the appearance of fine gold. Different mixtures can be employed for coloring gold, the two below giving very good result.

After a final scratch-brushing, the article may be gilded in an ordinary gold solution without the addition of mercury, by which the richness of color of electro-gilding and the durability of fine gilding are combined.

This kind of gilding is accomplished with much less trouble and, what is of great importance, is attended with less danger than fire gilding by the old method, which requires the continual handling of a large quantity of mercury, so injurious to health.

If any places or portions of the article do not require gilding they may be kept from being thus treated by a coating of copal varnish mixed with a little rouge powder, and drying in a warm place before immersion in the gold solution.

The same method may with advantage be applied to electro fire-silvering by using silver solution, and the result is excellent.

Care must be taken that the mercurial gold or silver solutions are kept apart from the ordinary gold and silver solutions.

Silvering by fire has been very much neglected and preference given to electroplating, but fire-gilding is still practiced to a considerable extent. Careful perusal of the above cannot fail to convince the reader that this combination of electro fire-gilding not only fully replaces the ordinary and antiquated process of fire-gilding, but effects at the same time a great saving of precious metal which would unavoidably be lost in fire-gilding, while at the same time possessing all the advantages to be derived from that method.

In the subsequent dippings they are only left in the liquid one minute. Articles colored in this way have a light color, but watered appearance. They are repeatedly washed in water in order to remove the last trace of the liquid and then dried in soft sawdust that has been warmed. Instead of drying in sawdust they can be dipped in hot water the last time and left in there a few seconds. When taken out the water that hangs on them will evaporate almost instantly.

The second method of coloring gold alloys is by means of a mixture of 115 parts of white table salt and 230 parts of nitric acid, with enough water added to dissolve the salt. This is boiled down to a dry mass of salt. This salt is then put into a porcelain dish and 172 parts of fuming hydrochloric acid poured over it and heated to boiling. As soon as the suffocating odor of chlorine is perceived the articles to be colored are dipped in. The first time they are left eight minutes in the liquid. In other respects the treatment is the same as above described.

Articles polished previously do not again require polishing. Care must be taken not to inhale the dangerous gas. The operation must be conducted under a draught chimney or out of doors.

School of Optics.

The following students attend the course of optics in Dr. Bucklin's school, which commenced January 10.

Philip E. Vreeland, Flemington, N. J.; Jacob Kemery, Downingtown, Pa.; Charles Weber, Haskellstown, N. J.; Frank Kline, Spring City, Pa.; John G. Buck, Carrollton, Ohio; Chas M. Barnes, Enosburgh Falls, Vt.; J. Kendall Smith, Newark, N. J.; Herbert J. Goodell, West Burke, Vt.; Reuben S. Rosenbloom, Syracuse, N. Y.; Leopold S. Gimberts, Eausville, Ind.

Another class will probably be formed about February 17th.

MATOON, Ill., Jan. 20, 1891.

I shall be glad to receive THE CIRCULAR every week now instead of every month as heretofore. It is a paper to swear by.

ED. H. THIELENS.

A Useful Tool.

IT is easy to alter an old, fairly large depthing tool for the purpose, as shown in cut. A bracket, *a b*, may be thus fastened between the two centers, *c* and *d*, and be so firmly united with it that the three pieces form only one. The two centers move so easily in the bearings of the tool that they are constantly

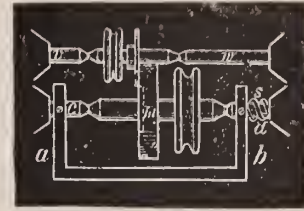

pressed to the other side by the cylindrical spring, *s*. Between the two centers runs the turning arbor with a

disc, *m*, of iron for grinding, or of composition or brass for polishing. Between the two other centers, *v* and *w*, is mounted the object to be polished, furnished in the same manner with ferrule and bow, but the strings are laid around in such a manner that the two parts move in opposite directions.

According to the nature of the work for which they are to be used, the discs serving for grinding and polishing must also be shaped conformably, as has been shown by the dotted lines. For polishing of faces, planes of ratchets, etc., they must be made somewhat free within as well as to the opposite sides. For pivot polishing they must be made true in their height, be truly straight and flat, and in working be moved somewhat to and fro from *d*, so as to obtain a uniform polish and to prevent the wearing of hollows. The tool is well adapted for polishing center-wheel pivots for anchor and cylinder watches, as the grinding off of the gilding from the wheel is thereby prevented. Besides this it is excellent for polishing the shoulders and grooves of the balance staff of fine watches, as well as long pivots and arbors; which, of course, require discs of different shapes.

Book Notices.

Reglement Relatif au depot et la Comparaison des Chronometres a l'Observatoire de Geneve. [Switzerland].—The purport of the little pamphlet of fourteen pages is in its title: "Regulations Concerning the Disposition and Comparison of Chronometers at the Geneva Observatory, adopted November 21, 1890." As THE CIRCULAR desires to recur to the interesting pamphlet at some future time, it simply acknowledges the receipt and expresses its thanks for the present.

Almanach des Horlogers, pour l' an 1891. Sixieme annee. Editeur Chas. Gros fils. Saint Imier. [Switzerland.] Price, One franc.—Of the many periodical publications appearing on the exchange table of THE CIRCULAR, there is indeed none that is expected or perused with greater interest than the Almanach, the volume of which is increasing yearly, while its reading matter is of exceeding interest to the watchmaker versed in the French language. THE CIRCULAR is obliged for the kind attention shown by the transmittance of a copy.

"PRINCES and Kings desired it long, but died without the sight."

MORE POPULAR THAN EVER.

THE

"BRYANT" INITIAL RING.

Patented May 12, 1885.



In its numerous styles, most easily interchangeable, handsomest and best. In elegant Trays of Six or Twelve, with extra Initials. PREFERRED TO ALL OTHERS!

EVERYTHING IN

Fancy Stone and Other Styles of Rings,

FOR SPRING TRADE.

A Timely Criticism.

WE are always glad to receive communications on any subject that is within legitimate range of THE CIRCULAR'S function, and welcome criticism and praise equally. The following letter, a criticism on one of our Work-shop Notes, has been received at our office:

WILCOX, Neb., Jan. 10, 1891.

To the Editor of the Circular:

The article on Page 74, of the January number, "How to Set a Jewel Pin," in my mind is not correct: 1st. Why do you remove the hair spring? You say to prevent the heat from drawing the temper. Very well! I ask how are you to set the roller hot enough to melt the shellac without drawing the temper from the balance staff rivets? 2d. The roller can be removed almost as quick as the hair spring, thereby avoiding danger of damaging the balance staff or pivots. Let us hear from you, Brother JEWELER.

Truly yours,

H. W. OVERSTAKE.

The criticism is just and worthy a reply. But Mr. Overstake should have noticed that the note to which he refers was contributed, and we gave it for what it was worth. The following, however, will, we believe, give better results than the method mentioned by our critic:

To FIT A RUBY PIN.—Light your alcohol lamp. Take either a file or a piece of steel wire with a flat end; place the wire in the flame, say about one inch from the flat end and apply the flat end to the table or roller, to remove the old ruby pin. This accomplished, fit a new pin to the fork, put it into the roller, lay a small piece of shellac at the end of the pin behind the roller and hold the heated end of the wire to the front side of the roller. The heat of the wire will cause the shellac to melt and run through the hole, thereby securing the ruby pin. While it is cooling straighten the ruby pin with the end of the wire. It is self-evident that no undue amount of heat should be applied, as it would burn the shellac.

A Bamboo Main Spring.

A LADY friend who is a missionary in Japan sends the following story for the truth of which she vouches:

A gentleman of her acquaintance while up in the country on a vacation, discovered that the mainspring of his watch was broken. He took the watch to a native jeweler who repaired it and delivered it to him apparently in as good running order as ever. It ran all right until the rainy season set in when it stopped. Being in the city of Tokio at the time he took it to an English workman who, on making an examination, was astonished to find that the cunning Jap had put in a spring made of bamboo which, so long as it was kept dry, remained elastic; but during the wet weather it had gathered dampness and lost its power.

ONARDO, Ill., Jan. 19, 1891.

Please find enclosed postal note for subscription. Keep sending THE CIRCULAR without delay as I prize it above all others.

LOUIS RATZESBERGER.

TRADE
SEAMLESS
 MARK.
GOLD · FILLED · CHAINS.

ON ACCOUNT OF

THE great popularity of the chains made exclusively by us for the past three years, the air has been FILLED and the paper of the various Jewelers' Journals COVERED with the word "SEAMLESS" which has been and is our trade mark.

We never had such a boom in our business as we have had since our friends commenced to advertise our goods.

We have only a word to add, and that is we make and sell the

ORIGINAL AND GENUINE

SEAMLESS GOLD FILLED CHAINS.

In addition to the word SEAMLESS and for the protection of our customers we place upon each Chain a tag bearing the following trade-mark :



Which is affixed by authority of its owners, as a guarantee that the Chains are made from the Burdon Seamless Filled Wire.

BOSTON OFFICE,

6 WINTER STREET,

In charge of

I. W. STELLE.

NEW YORK OFFICE,

17 Maiden Lane.

PACIFIC COAST AGENCY,

WM. E. PETTES & CO.,

PHELAN BUILDING,

SAN FRANCISCO, CAL.

Address all communications to

KENT & STANLEY,

PROVIDENCE, R. I.

A. RICKERT C.A. STIEHLE
RICKERT & STIEHLE,
 MANUFACTURERS OF
GOLD CHAINS,
SWIVELS AND SPRING RINGS.
 Chain Repairing a Specialty.
 13 & 15 Franklin Street, NEWARK, N. J.

GENTLEMEN:—I think the trade this Spring will be better than last, and, although I can turn out double the work I did then, you had better be on hand with your orders, for I expect that my sales will be very large—equal to last Fall, if not double. You see the field is constantly widening and the demand is increasing, and why? Did you ever stop to think that there are 65,000,000 people in the United States, and the per cent. of this number that use glasses is one-fifth, or 20 %, making 13,000,000 people wearing eye-glasses, and if you count the myriads in Europe and South America, why it is simply immense, and it needs cultivation. Why! Gentlemen, we ought to be able to double our business every year for the next ten years.

Yours respectfully,
 Springfield, Mass. S. F. MERRITT.



Electro-Gold and Silver Plating.

Why Ordinary Electro-Plate Does Not Last—How to Obtain Good Results by a Simple Method.

COMPLAINTS are quite frequent concerning the non-durability of the ordinary gold and silver plating by contact or limited electro-battery, and to the wear when exposed to friction or weather. And unfavorable comparison has been made with the old fire gilding. The former, however, is generally acknowledged to have the richer appearance. The primary cause for the complaint lies in the fact that deposits of the precious metal by the galvano-electric system are not solid and compact. Electro-gilt ornaments, balls, eagles and other devices such as are used to decorate monuments, public buildings etc., tarnish rapidly because of this unsound and porous deposit upon the metal case.

To produce substantial and lasting deposits by electricity, it is necessary to use dynamo-electric apparatus operated by steam or batteries of great power. The expense necessary to the purchase and operation of such a plant is practically prohibitory to the jeweler or watchmaker whose business is conducted upon a limited scale; and who, even if in a financial position to purchase and maintain these expensive apparatus, does not have sufficient work to realize a profit large enough to warrant the entailed expense. To avoid this expense and at the same time secure a good, lasting deposit by electricity, the following method is recommended as effective.

To the ordinary gold solution for electro-gilding add some mercury previously dissolved in nitric acid. This solution should be diluted with water and neutralized of the acid by adding small quantities of spirits of ammonia until immersed litmus paper does not change its blue color into red. Previous to dissolving the mercury in the acid, it is necessary to free it from the lead with which commercial mercury is generally contaminated. This may be effected by pressing the mercury through a piece of wash-leather which will allow the mercury to pass through by squeezing. The leather will retain the lead and leave the mercury pure.

This prepared gold solution will be a mercurial gold amalgam of a fluid or watery nature, and should not be mixed in larger quantities than required for immediate use. The articles to be gilt are immersed in this

solution appended to the wire in connection with the colbode (zinc) of any battery, and will receive a gold deposit of quicksilver appearance after the article has remained a sufficient time in the solution. When withdrawn, rinse in water and lay on a fresh fire made of small pieces of charcoal until the mercury has evaporated. This will take place very soon, as the quantity of mercury is small in proportion to the gold deposit, although the color of the former predominates. After the evaporation of the mercury, the article has all the characteristics in color and toughness of fire-gilding—pale yellow and dead surface. If the article is then scratch-brushed in beer it will assume a fine lustre. If a strong deposit of gold is required the operation may be repeated after each scratch-brushing. By weighing the article before its first immersion into the gold solution and again after the last scratch-brushing, the weight of the gold deposited can be ascertained very accurately. In the last evaporation, the article should be left for about one-half minute or so longer on the fire than necessary for driving off the mercury, to deepen the color of the gilding.

Mix together two parts of saltpetre, one part of table salt and six parts of alum, with six and one-half parts of water and warm the mixture in a porcelain vessel. As soon as it begins to rise add one part of hydrochloric acid and bring the contents of the vessel to a boil, stirring in the meantime with a glass rod. The articles to be colored, suspended on hooks made of strong platinum wire or of glass, are first dipped in sulphuric acid and then entered into the slowly cooking solution last described and moved to and fro in it. In about three minutes they are taken out and dipped into a large vessel of water, so as to see what color they are. If the desired shade is not yet obtained they are dipped in again as often as necessary until it appears.

DANVERS, Mass.

I am a young subscriber to your excellent paper and like it *very* much. What it treats it treats well. I am glad to notice that it pays more attention to giving first class instruction and suggestions in watch repairing than formerly.

J. W. BABBITT.

LANCASTER, Pa., Jan. 19, 1891.

I have learned much from THE CIRCULAR, and through it have become familiar with the trade.

N. M. OBERLY.

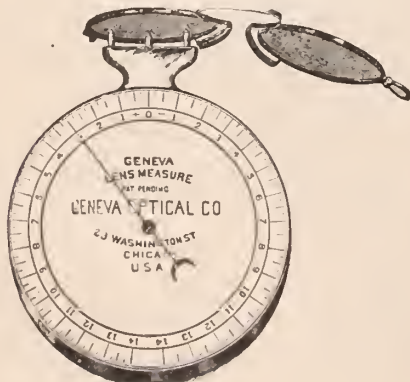

SEXTON BROS. & WASHBURN,
 41 MAIDEN LANE, NEW YORK,
 MANUFACTURERS OF
FINE JEWELRY,
 INCLUDING A FULL LINE OF MOUNTINGS.
 PROMPT AND CAREFUL ATTENTION GIVEN TO SPECIAL ORDER WORK.



THE PAIRPOINT MFG. CO.
New Bedford, Mass.

FINE
* GOLD *
AND
SILVER

Plated Ware.



No. 110. COFFEE SET.

OUR LARGE LINE
OF
STAPLES
AND
NOVELTIES

WILL BEAR INSPECTION.

Quality
Guaranteed.

NEW YORK.

CHICAGO.

SAN FRANCISCO.

FOR CLEANING AND POLISHING.

THE LATEST AND THE BEST
POLISH
FOR
SILVER GOLD, NICKEL
AND GLASS.



WILL NOT SCRATCH
THE
FINEST SURFACE.

EVERY RETAILER OUGHT TO HAVE IT IN STOCK.

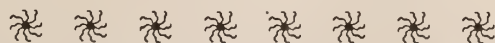

DAVID F. CONOVER & CO.

PHILADELPHIA, - - - - - PENN.

Paris News

THE winter season, which is the harvest time for jewelers and silver smiths has been a rather prosperous one this year. It is but fair to acknowledge that our people did their best to prepare for its coming. While the snow was everywhere on the ground, our jewelry shops, like so many elegant hot houses, were crowded with flowers of all kinds. A few orchids in enamel still appear here and there in our best places, but French people have, in general, a decided preference for daisies, pansies, forget-me-nots, roses, sweet-briars and even poppies made of precious stones or enameled gold with gems in the heart of the flower.

Among fancy brooches, I noticed a clown's, or rather a *pierrot's* head made of a moonstone breaking through a pretty oval stained glass, circled with a green gold cord.

Some highly artistic brooches are made in translucent enamel on relief, or *basse-taille*. They exhibit mediæval scenes, introducing princes, noblemen and ladies in gorgeous costumes of various colors. The real appearance of embroidered velvet is wonderfully reproduced, with all the shades between the folds. It is done as follows: A plate of

twenty-two carat gold, no thicker than a five centimes piece is carefully hammered, so as to make it even, smooth and dense. After this the design is drawn with the point of a graver, and the different reliefs obtained through cutting the plate down with scorpers variously edged. The whole of that ground work is then delicately finished off (without hammering), and so as to leave hollows for the shades, and reliefs for the lights. That work is then covered in the usual way, with translucent enamel giving the desired colors. If all has been well managed the effect is magnificent. One of these brooches, which is being made to order, represents in rich mediæval costumes several members of a well-known aristocratic family.

A very curious style in jewelry consists of light floral ornaments made of diamonds with deeply oxidized silver mounting. The setting of dead black brings out strikingly the brilliancy of the stones or throws on them a dark reflection, according to the way you look at them. I have seen an elaborate diadem, a handsome necklace and a very elegant bracelet made in that fashion.

Imitation jewelry has reached such a high standard that we can hardly imagine that it will ever be more perfect. The worthless stones are so cunningly cut and so artfully backed that very often all but people in the trade mistake them for real gems. The setting is simply wonderful. Now, if we consider gilt brass as jewelry we may boldly assert that for artistic finish it is seldom in-

ferior to high class *bijouterie*, in spite of the necessity for doing quick work. All stampers used in the cheap lines are in steel and engraved by the very best hands, so that the base metal receives an artistic impression. These pieces come out so neat that they need not be polished before gilding.

This is hardly the wedding season; but we all know that the God of Love does not always submit to the dictates of Society. In consequence I have to mention the marriage of Mdl. de la Briere with M. Le Clerc, which took place at the *Nonciature*, in Paris, on the 7th of January. Besides the numerous cases containing sets of pearls, diamonds and sapphires, I noticed a pretty little Louis Seize clock given by the Duke de Chartres, and a very elegant casket from the Countess de Nétumieres, the actual owner of the Rochers-Séviigné. The donor of the beautiful casket placed in it a bouquet of orange blossoms plucked from the old orange trees of Madame de Séviigné, as a delicate attention to the bride's father, who has recently published a book on the happy days spent in Brittany by the illustrious lady writer.

JASEUR.

It will be Better.

SANTA ROSA, Cal., Jan. 23, 1891.

Enclosed please find express order, \$2, for my subscription for the ensuing year. I am glad you are going to make a weekly of it, and if it is as good as the monthly it will be hard to beat.

GEO. HOOD & SON.

The R. Wallace & Sons Mfg. Co.,



No. 230 CUP. IN STERLING SILVER, TWO-THIRDS SIZE.

MANUFACTURERS OF

Sterling Silver, Plated Ware & Fine Cutlery

FACTORIES, WALLINGFORD, CONN.

{ New York Store: 3 Park Place.
Chicago Store: 104 State Street.



Easy Lessons for Opticians.

BY DR. C. A. BUCKLIN, A.M., M.D.

Continued From Page 48, Feb. 4.

STARTING with the proposition that any one of the possible conditions may be present, we commence our process of exclusion by experimenting with trial lenses. We try convex lenses first. If these decidedly improve distant vision, and if through them the lines of the astigmatic fan appear equally black and we are not able to improve the distant vision by the additional use of cylinders, then we have not only excluded every other possibility, but we have demonstrated that simple hyperopia alone exists.

If simple convex lenses improve distant vision, the line of the astigmatic fan appear unequally dark, and we can still further improve vision by the addition of cylindrical lenses, then we have simple hyperopia combined with astigmatism as the cause for the defective vision.

If convex lenses are entirely rejected and we improve distant vision to a satisfactory extent by the use of concave lenses, then we have a form of myopia which, owing to complications, makes near vision difficult. Myopia, under these circumstances, is complicated with astigmatism or difficulties of convergence at the reading distance. This is due to either weak internal muscles or the near point at which the myopia makes it necessary to hold the work.

If concave lenses improve the distant vision decidedly, and the additional use of cylinders produces an additional improvement of the vision, we have myopia complicated by astigmatism as a cause of the defective vision.

If distant vision is not improved by either concave or convex lenses, then try convex cylinders at all axes. If these improved vision to a satisfactory extent, we have excluded all possible conditions but simple hyperopic astigmatism which we have demonstrated as existing.

When the convex cylinder improves vision only to a moderate degree, we determine what kind of a cylinder, convex or concave, produces the greatest improvement and selecting the better one, we cross it with a weak cylinder of the opposite value. When this combination improves vision decidedly we have mixed astigmatism as a cause of the faulty vision.

If convex cylinders are entirely rejected we next experiment with concave cylinders. If these improve vision to a satisfactory degree we have simple myopic astigmatism, existing as a cause of the defective vision.

If no combination of lenses improves the defective distant vision we have an obscurity

of vision or a disease of the *optic nerve retina choroid or brain.*

When the distant vision is acute in young people and they experience difficulty at the reading distance, they usually have latent hyperopia. But they may have muscular asthenopia, which can be located by properly testing the muscles. Having succeeded in excluding defects of the ocular muscles and latent hyperopia, the only remaining defect possible is some diseased condition of the ciliary muscle, which our method of exclusion has demonstrated to exist because it has demonstrated the absence of every other possible defect.

When persons are over forty-five, presbyopia will complicate every other defect and require attention at the reading distance in all but myopic cases.

Having demonstrated that one has defective distant and near vision which is in no way improved by any optical appliances, we are forced to the conclusion that he has an obstructive lesion by which the perfect entrance of light to the retina is compromised; or he may have a faulty perception of the retinal image, a faulty conduction of the impression by the optic nerve or a failure of the brain to appreciate the impression conducted to it.

In our next lesson we will take up the exclusion method as applied to obscurities of vision and diseases of the optic nerve, retina and brain.

JOHNSTOWN, N. Y., Jan. 24, 1891.

DR. C. A. BUCKLIN:

Will you kindly inform me in regard to the following case? Young man about 26, school teacher. R. E. + 55 gives normal vision; with left eye + 1.5 gives the best results, but is far from normal. Complains that the letters look large and distinct enough, but in reading the letters crowd very close together. Has no astigmatism. The crowding of the letters together is what gives me trouble. If you could give me a pointer will be very much obliged.

Yours respectfully,

E. FAIRCHILD.

The symptom complained of by this patient is due to micropsia or small vision. This is produced by the side and cones of the retina being drawn from each other in such a way that the retinal image of large objects falls on rods and cones upon which the retinal image form smaller objects formerly fell. Occasionally irregular astigmatism causes similar complaints. The former solution is the probable one.

A Young Jeweler Disappears.

POTTSVILLE, PA., January 30th.—Thomas Coombe, a young Mahanoy Plane man, has disappeared, and with him has gone considerable that was not his own. Young Coombe recently opened a small jewelry store, where he appeared to be doing a pretty good business. Lately he formed a watch club, the members of which very promptly paid up. With the advent of the watch club Coombe became quite a sport, and spent money very freely. The other day he quietly informed his mother that he was about to take a trip, and tried to borrow money of her, but was unsuccessful. He did not return in the evening, and nothing has since been heard of him. Financial troubles are said to be the cause of his disappearance.

Providence.

A VERY clever swindler has been at work in Providence during and ever since the holidays. He deals in clocks and his *modus operandi* is this: He goes up to the door of a comfortable lodging house asks to see the lady and produces his wares, representing himself to be an agent of Tilden & Thurber, (a firm occupying a business position corresponding to that of Tiffany in New York) but is held by a \$3,000 bond not to sell more than three clocks on the street a day. He takes \$1 or whatever he can get, paid down, and lets the rest be paid by installments. The whole price of each being much less than they could be bought at Tilden & Thurber's. He says he is working on a salary of \$1,000 a year and unhesitatingly refers them to Tilden & Thurber. The clocks are cheap imitation marble affairs with the Welsh movement, and he represents them to be Howard clocks and guarantees them to last fifteen years, while in reality they will last hardly half as many months. He has been remarkably successful throughout the city, and Detective Murray says he is one of the coolest swindlers and best salesmen he ever heard of. The difficulty is that he has done nothing criminal in his sales and cannot be held. He confessed to the authorities, when arrested on suspicion, in a tone as much as to say: "What are going to do about it?" Now that his scheme has been exposed, he will probably leave the city at once.

One of the largest lines of plain and ornamental rings ever seen on the market is that which is being shown this season by Ostby & Barton, and contains many new, novel and original designs. So extensive has the business of this firm become that they have found it necessary to lease and occupy the entire building at 80 Clifford street.

Capt. Charles G. Bloomer, of C. G. Bloomer & Sons, has been appointed a member of the conference committee, and Capt. Charles G. Bloomer, Jr., a member of the nominating committee of the Rhode Island Yacht Club.

Joseph C. Taylor has gone out of the stone business in the Wilcox Building, 5 Custom House street, and will now devote his whole attention to the affairs of Taylor & Cole, manufacturers of findings at 14 Page street, of which he is a member. Arrangements have been made whereby the lines formerly controlled by Mr. Taylor have been placed as follows: Richards & Brome will carry Hahn & Co's line, and Max Meyerheim that of Jules Gruet.

The spring campaign has fairly opened and most of the manufacturers have their representatives on the Western circuit and almost without exception they are meeting with flattering results. Among the salesmen West are: Byron D. Pitts for George Pitts; Jason E. Braman, for P. S. Eddy; B. F. Snow, for George L. Vose & Co.; C. W. Edwards for Fowler Bros.; Jerome M. Fitzgerald, for Michael Fitzgerald & Co., and Charles Battey for Waite, Mathewson & Co.,

Albert B. Bushee and family are taking in the gayeties of Providence for the winter. They are at the Narragansett Hotel.

John T. Cuddy has been appointed by the Municipal Court as administrator of the estate of the late Michael Cuddy, bond \$2,000.

Some of the manufacturers are enjoying brisk business. Orders have come in so thick that a few firms are talking of running overtime.

At the last meeting of the Rhode Island Business Men's Association, the firm of Howard & Son was elected to associate membership.

Dissatisfaction with the express company's excessive independence has been a bonanza to new a local line running to Providence. The jewelers have given it a large share of their patronage.

Representative Horton, head of the firm of Horton, Angell & Co., is learning the ropes of the legislature this winter. He had a little skirmish to get the nomination, but every one is satisfied that he will make a good representative.

The annual rumors of the erection of new factories, have not come into circulation this year. There is a popular belief that they would be occupied, if the capitalists would build them.

Adna T. Howe of Olneyville, R. I., has an old-fashioned time-keeper whose history can be traced back to 1730. It was made at Lexington, Mass., and is a valued heirloom in Mr. Howe's family.

Joseph H. Fanning has been elected president of the Society for the Prevention of Cruelty to Children; also a member of the Auditing Committee of the Rhode Island Horticultural Society.

Samuel H. Bailey, of Foster & Bailey, has been elected a vice-president and Ansel L. Sweet, of G. B. Willis & Co., a member of the executive committee of the Methodist Social Union, of this State.

There are several restive young men in town, who have laid away a little money, that are talking about a co-operative jewelry manufacturing concern. Whether it is all talk will be known early in the spring. The same project has been broached a number of times before.

J. T. Hunt will represent John T. Cuddy & Co. this season; R. L. R. Everett represents A. B. Day & Co., and W. S. Godfrey will take the market for George A. Schuyler & Co., of Pawtucket. John T. Hamer, for ten years bookkeeper for S. Albro & Co. is now with Charles Downs.

It seems that men who have once been in the jewelry business cannot stay out of it. The latest instances of this, are those of W. A. Sturdy and W. H. Wilmarth, both of whom have just returned to active operations in the line, after having formally retired to enjoy their "winnings" at the business.

G. A. Gardiner, for many years manager of the stationery department with Tiffany & Co., New York, has been engaged by Shepard & Co., this city, to manage their jewelry and stationery department.

There is some talk of a corporation taking up the business of a certain old-established firm, and pushing it for all there is in it. Names cannot be mentioned, but it will be a big thing if it is carried out.

In the matter of failures the following extract from the annual report of Secretary Marcus W. Norton, of the New England Manufacturing Jewelers' Board of Trade, will afford an excellent idea of the number and their extent:

During the past month a new firm by the name of Ohler, Remlinger & Felder has started in business and the following changes have occurred: Hagan Bros. succeeded by Hagan, Fuller & Co.; W. H. Eaton & Co., removed from Central Falls to corner Main and Broad streets, Pawtucket; Andrew J. Wiley, 363 Eddy street, out of business.

The failure in which the Providence jewelers were most interested was that of Sumner Bros., of Cleveland, whose liabilities were estimated at from \$250,000 to \$300,000, and the assets at \$75,000 to \$100,000. The members of the Board of Trade hold claims amounting to about \$10,000, while other jewelers in this vicinity hold for a similar amount.

During 1890 there were thirty-four failures in which firms of this city were interested, the number of members of the Board who were creditors aggregating 283, with a loss of \$56,482.34. On an average, it is estimated that the members of the Board of Trade constitute about two-thirds of the firms interested as creditors, and upon this basis the number of creditors interested in the thirty-four failures would be 425, and their aggregate loss about \$75,000.00. In the collection department of the Board 279 claims have been received, of which 165 have been collected in full. Seventy-nine are now pending, fifteen returned as uncollectable, seven withdrawn and thirteen reduced to judgment. The amount collected was \$17,914.11, of which about \$10,000 was without expense to members.

To Put in an Arbor.

IN selecting an arbor for a Swiss watch, choose one that has a ratchet nearly as large as the sink in the bar will admit. Having seen that the ratchet runs through to the centres, proceed to turn the top of the ratchet flat (the squares are usually cut to these arbors) and cut a slight hollow at the root of the square to prevent the oil being drawn up. Reverse the piece in the turns, placing the ferule on the square and turn the underside of the ratchet flat; have it slightly in excess of the thickness it is to be when finished in order to allow for finishing. Now mark the height of the nut and turn the arbor down to fit the hole in the screw-plate. A barrel

arbor should be used for this purpose as the ordinary plate has too coarse a thread. The diameter of the part to be screwed should be such that a barely full thread will be formed. If the diameter be too large the thread is likely to strip off. That part of the arbor which will ultimately be cut off should be turned slightly tapering so as to form a guide to start the plate, thus avoiding a "drunken" thread. Now screw the arbor, holding it by the square in the pin-wise. Turn down the shoulder which passes through the bar, having it very tight in the hole. The height of the shoulder should be measured from the upper side of the ratchet with the tenth measure.

Next turn the pivot on which the barrel revolves, having it also very tight in the hole. Finally turn the lower pivot and have it very full in the hole. Mark the length of this pivot with the tenth measure also; cut the stop finger, put it on and mark and drill the place for the pin-hole.

The arbor is now ready for hardening. Twist a piece of binding-wire a few times around the body of the anchor and plaster some yellow soap all over it. Hold the whole in the flame of the spirit lamp until red hot and then plunge vertically into water. Take care not to overheat it, using the lowest temperature that will harden, for if it is made too hot it may get out of true. The soap is used to prevent burning and also to improve the quality of the steel. It should come out of the water without any scale—or if with scale, so little that it can be easily removed. Now place the arbor over the lamp in a spoon filled with oil and hold there until the oil ignites. It is now ready for polishing. Proceed to polish the pivots and shoulder perfectly square and flat in the usual manner, first with the steel and oil-stone dust, finishing with the bell-metal and rouge.

Having roughed out the nut and drilled the centre-hook and the two turnscrew holes, tip and turn it to thickness on its own arbor, leaving it slightly thick. Harden and temper in the same manner as the arbor, rub down the sides smooth and polish flat. Insert the arbor in the barrel and screw on the nut. If the barrel has too much end shake, turn back a shade the shoulder against which the barrel nut bears. If care is taken in measuring the heights no difficulty will be found in this respect. Rub the squares smooth with the steel polisher and oil-stone dust, shorten, and polish off the ends either on the cement chuck in the balance tool or in a lantern of the Swiss screw-head tool. Take off the corners of the squares with the oil-stone slip. If the end of the square is required dead flat the fuzee-end tool must be used.

The process of making a barrel arbor has been so minutely described because many watches come to the repairer's bench which have arbors that have failed in their purpose, viz: to support the barrel truly parallel to the plane of the plate and to allow it to turn truly and yet with no shake. If some such tool as that mentioned be not used for polishing the shoulders and pivots it will be impossible to make a true and accurate arbor.

HOW TO RECOGNIZE THE TRUE

WEBSTER-WHITECOMB • LATHE.

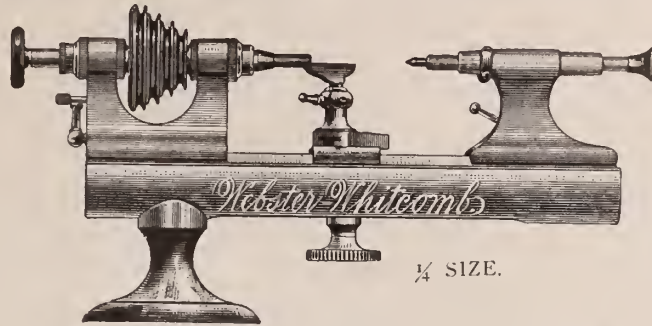

THIS question is often asked: "How shall I recognize an *imitation* from the *true* 'Whitcomb' or 'Webster-Whitcomb' lathe?" To this we reply: "All our lathes bear the word 'Whitcomb' or 'Webster-Whitcomb' also the word 'hard' or 'soft' to indicate the temper of the bearings, also the number of the lathe (all of our lathes being numbered consecutively) either on the bed or the headstock (latterly on the headstock only). The bed always bears the words 'American Watch Tool Co., Waltham, Mass.' The words 'Whitcomb' and 'Webster-Whitcomb' are our trade-marks, and up to the present time no imitator has dared to use them. The first attempt to use them or our patented features will be immediately followed by a suit at law. With every lathe we send the following guarantee:—

"This certifies that the lathe marked 'American Watch Tool Co., No. —' was made by us from the best materials, on the most approved plan, and is a reliable lathe. For any defect in material or workmanship we hold ourselves responsible. Notify us promptly of any faults.

"Waltham, _____

AMERICAN WATCH TOOL CO.

By _____"

This guarantee is also signed by the inspector who has the final inspection of the work. For several years past we have tied upon every lathe a tag of caution and instruction. All purchasers are requested to demand these documents with the lathes they buy. Remember our address:

AMERICAN WATCH TOOL CO.,

WALTHAM, MASS.

STONY BATTER WORKS.

IMPORTANT NOTICE.

The New Trenton Movement.
H.T.G and O. F. S. W.



(OPEN PLATE.)

No. 40, Nickel, - - - \$4.00
No. 41, Gilt, - - - 4.~



(CLOSED PLATE.)

No. 60, Nickel, - - - \$3.75
No. 61, Gilt, - - - 3.75

LESS CASH DISCOUNT.

We beg to notify the trade that we have placed on the market a NEW MODEL

18-Size, Seven Jeweled, S. W. Nickel Movement,

SURPASSING ANYTHING YET MADE FOR THE PRICE, and to which we invite your attention. These movements possess several new features which offer special advantages to watchmakers. They are Quick Train, Straight Line Lever Escapement, and have Safety Centre Pinions and hard enamel Dials. The barrel can be removed without disturbing the train or stem-winding parts. They are beautifully damaskeened, well finished and attractive in appearance and are EXCELLENT TIMEKEEPERS. EVERY MOVEMENT FULLY WARRANTED.

The Best Low Priced Movement in the Market.

FOR SALE BY THE JOBBING TRADE.

Send to your jobber for a sample movement. If he does not keep them, write us and we will furnish you the names of jobbers who do.

TRENTON WATCH CO., Trenton, N. J.

Burdon Seamless Filled Wire Company,

MAKERS OF

The Original and only Genuine and Perfect Seamless
Filled Wires in the World.

SOLD TO ALL MANUFACTURERS ALIKE.



THE SUCCESS of the Burdon Seamless Filled Wire, like that of all important inventions, has been followed by deceptive and imperfect imitations. For the protection of

ALL JOBBERS and RETAILERS,

We authorize manufacturers who so desire, to affix upon the tag, card or label accompanying the articles made from this wire, the following registered trade-mark which is owned by this Company.

S
E
A
M
L
E
S
S

BURDON



WIRE

TRADE -

MARK

S
E
A
M
L
E
S
S

The bird-on-wire is a guarantee that the goods are made from the original Burdon Seamless Filled Wire, the reputation of which has been firmly established among the best dealers for more than two years. The perfection and qualities of the Burdon Seamless Wires are always guaranteed. All Dealers (jobbers and retailers alike), should, therefore, demand goods made from the original Burdon Wire, and avoid imitations which are offered as "just as good."

BURDON SEAMLESS FILLED WIRE CO.

109 to 119 and 127 Summer St.,

PROVIDENCE, R. I.

The Torry Bankrupt Bill.

CHICAGO, Jan., 31, 1891.

To the Editor of *The Jewelers' Circular*:

GENTLEMEN we have been requested to ask you to publish in the next number of your journal the enclosed letter relative to the Torry Bankrupt Bill.

The letter appeared in *The Economist*, the most widely circulated trade journal of the northwest last week, and as it was written by a gentleman formerly connected with the jewelry trade and discusses a subject which is engaging the attention of the business men of the country its publication in your journal would, it is believed, be acceptable to the readers of THE CIRCULAR and gratifying to the supporters of the bill, among whom no more earnest advocates can be found there than the jewelers of Chicago. Very respectfully,

CHICAGO JEWELERS' ASSOCIATION.

To the Editor of *The Jewelers' Circular*:

I am constrained to briefly answer a letter which has appeared in pamphlet form, relating to my former communication on the Torry Bankrupt Bill, and wish to address those in particular who have not read its provisions. The proof is unquestioned that the opposition to this law comes from a few, less than five per cent., of the merchants of the country, namely, the "never compromise" ones, and rests upon a strictly selfish basis. To realize this fact we simply need to inquire into the number of houses that hire a lawyer by the year, at a liberal salary, to watch their accounts, with the special intention of being first and foremost, always and forever, in the failure of every unfortunate debtor.

It does not matter how many creditors there are, nor the proportions of assets to liabilities, nor what sacrifice is to be made of the assets, so long as this class secure themselves to the last cent. And always, of course, at the expense of the others. Blameless management, unavoidable disaster, the future of the debtor, and the interest of other creditors receive no consideration at their hands. These merchants and their attorneys cry that this proposed legislation is wanted by "collection agencies" and "manipulated commercial bodies;" that there is no call for it on the part of debtors,

and scarcely any on the part of the creditors. This statement hardly deserves notice as it is contrary to fact.

Strangely enough, another faction of the opposition asks for help from these same "collection agencies" and country lawyers, claiming, by way of inducement, that if this Bankrupt Law is passed it will rob them of their business.

The "manipulated commercial bodies" include nine-tenths of all the organizations of the kind in the country, and really embrace every first-class one; wherefore, the charge of manipulation is absurd.

It may be that a "layman" is not so well able to speak of the machinery of the new law, but I defy any critic or lawyer to show that the provisions of the Torry Bill do not avoid the objectionable features of the old Bankrupt Law. I have the authority of more than one lawyer, high in the profession, that it will work admirably, and I make no claim that cannot be substantiated by an unprejudiced, fair-minded man, whether lawyer or "layman."

Let any jobber examine his books and see if he does not find his insolvent accounts are of about the same nature as my own. For instance, in one case, assets \$21,000.00, liabilities, \$23,000.00, preferences, \$21,000.00, paid in full, mostly to a prominent Chicago opponent of National Bankruptcy Legislation, under a chattel mortgage, leaving nothing for unpreferred creditors. Again: Assets, \$7,600.00, liabilities, \$11,000.00, preferences, to relatives, \$4,500.00; paid in full, and again leaving nothing for remaining creditors.

The largest failures that have occurred in Chicago and elsewhere within a short time readily enable us to see how different things would be under a proper and equitable Bankrupt Law. Referring directly to the failure of R. G. Peters, involving millions, we find under the present "expeditious, fairly inexpensive" State laws there is a squabble among the creditors for the property wherever

found, with no ends of suits, garnishments, attachments, replevins, etc., all of which will wreck the estate, ruin the insolvent, prove a boon to the litigating lawyers, and will require years to adjust. How would it be in this one case under a uniform Bankrupt Law?

The alleged "extraordinary list of crimes and offences" in the pending measure relate only to acts in contemplation of bankruptcy, and it is specifically so stated. The expenses provided for by this law are the minimum and not a severe tax on the resources or assets. Other and unnecessary expenses nor provided for are at the option of the creditor.

In conclusion, I can only say that, after a business record of twenty years and from the knowledge of the experience of many personal friends, merchants of high standing, I have wofully failed to discover the "inexpensive and effectual conduct of the State courts," or that in the administration of any estate there has been expedition, satisfactory method, expense or result.

Franklin Discharged.

PHILADELPHIA, Feb. 3.—James Franklin, the young man who was arrested last week for robbing a Chester jewelry store, was given a further hearing by Magistrate Clement yesterday afternoon, as was also Adam Goldman, the second hand dealer, who is charged with being a receiver of stolen goods. Goldman yesterday admitted that he sold Franklin the watch and he was held for a further hearing. The detectives have arrested as they suppose the real robbers of the jewelry store, and Goldman will be used as a witness against them. Franklin was discharged.

A Jewelry Firm Fails.

DALLAS, Tex., Jan. 26.—Taber Bros. Jewelry Manufacturing Company, wholesale dealers in jewelry, assigned to-night for the benefit of creditors, John Alcott, assignee. Liabilities, \$30,000; assets not stated.

COMPARE

ALL OTHER GOLD FILLED CASES WITH THE CELEBRATED



**CROWN, LION,
EXCELSIOR
HAND ENGRAVED CASES.**

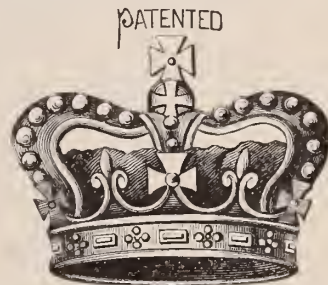

WARRANTED

MADE BY

H. MUHR'S SONS, 629-631 CHESTNUT ST., PHILA.

Brief History of Gold and Silversmithing.

(Continued from Page 33, January Number.)

PART II.

THE BYZANTINE PERIOD.

THE Byzantine period does not deserve very great attention. Some remarkable works were, no doubt, produced in those times; but their style of decoration was so extremely showy that they cannot be considered as models worthy of imitation. I do not think it necessary to enumerate the splendors of the Church St. Sophia at Byzance, or to attempt to describe any of the clerical vases it contained, which, according to an anonymous writer of the time, numbered forty-two thousand. Although the new cap-



NO. 8. CHALICE IN CHURCH OF ST. REMI.

ital of the Roman Empire was enriched with gorgeous monuments and dressed up, so to speak, in a way to impress oriental people with the grandeur of their rulers, Rome was not forgotten. Emperor Constantine offered some magnificent works in precious metals to the churches of that city. Among them were a baldaquin in beaten silver, weighing 2,025 pounds, and supported by eighteen figures, all in massive silver, and each one five feet high; a large gold lamp, adorned with fifty dolphins, weighing with its chain twenty-five pounds; four gold crowns; seven patens; seven cups; two vases, weighing fifty pounds each; fifty chalices of gold; besides innumerable candelabra, altars, basins, and various articles in silver; the aggregate weight of the gold work was four thousand pounds, and nearly forty thousand pounds for those in silver. Most of these were given to the Church of St. John de Latran. When Constantine died, his body was deposited in a gold coffin, which was placed on a raised platform, and surrounded with a number of gold chandeliers.

Most Byzantine pieces of orfevrerie consisted of a juxtaposition of flat surfaces covered with vari-colored enamel, generally opaque, blue being the predominant color. The surfaces were adorned with stones in cabochon symmetrically arranged and set in rather thick and salient bezels. Meanders of a coarse filigree ran around and between the stones. The outlines of the design were stiff and badly drawn. There was nothing refined about the workmanship.

Celtic, Gallic and Gallo-Roman works are only interesting from an archæological point of view.

Merovingian orfevrerie, which, according to recent statements, may possibly have had an Asiatic origin, is not unworthy of notice. Various specimens of it, made during the fifth century, can be seen at the National Library at Paris. The tray belonging to the Gourdon find, which was unearthed near Chalon-sur-Saone in 1846, is especially interesting. It is square in shape, and rather deep. The brim, which resembles a frame, is covered with lozenges of red glass. They look like garnets, are enchased in massive gold sockets and run between two rows of red glass

lentils. There is a cross of the same style in the center of the tray, and four hearts, one at each angle. These red glasses, showing on thin tin or silver sheets and marked with a kind of *guillochis*, are the chief features of the Merovingian style. The celebrated St. Eloi, who was born near Limoges towards the end the sixth century, made many important works. The best known among these is King Dagobert's throne. The most remarkable piece in point of workmanship which the illustrious goldsmith produced, is said to have been a gold cross, five feet high, covered with precious stones and most exquisitely finished. It belonged to the basilica of St. Denis. Unfortunately none of those reputed masterpieces have been preserved.

With the eleventh century opened a new era in gold and silversmithing. Among the works made during that period one of the most perfect is the chalice of St. Remy, reproduced by figure 8, which has been pre-

served at the National Library, Paris. It is in massive gold enriched with filigree ornaments and precious stones. The outlines are exquisitely elegant, and the proportions exactly what they ought to be. The decoration has the fullness and the weighty appearance, so to speak, that was expected of a piece of the goldsmith's art in those times. It is rich, yet not over elaborate for the period. We may look upon it as a thorough master-piece.

The scyphus, of the thirteenth century, belongs to the Louvre, and may also be considered a *chef d'œuvre*. Although in brass, like many other pieces of the same kind produced in that period, it has evidently been made by a goldsmith. The cup and its cover are decorated in *champlevé* enamel work and partly gilt, and garnets, emeralds and turquoises in cabochons are placed at regular intervals. The workmanship is remarkable. Bands divide the cover into thirty-two *champs*, sixteen quadrilateral and sixteen triangular. Each one of the eight large *quadrilateres* exhibits the figure of an apostle, rising up from clouds. The head in alto-relievo is applied on the cup, whereas the body is done with well cut engraving, the whole coming out on a blue lapis enamelled back-ground. Each of the other *champs* or panels contains the bust of an angel, worked in the same way, excepting the top triangles, which are filled up with ornaments. The body of the cup shows a similar arrangement. The narrowing top of the cover



NO. 11. SALT BY CELLINI.

adorned with flatly engraved *fleur-de-lis*, is well calculated to set off the knob, so richly worked, that surmounts it. All the details of it come out so plain on the illustration that I need not describe them. Four garnets, placed around the base of that knob, are set in relief. The stand, boldly decorated in open work, shows three men pursuing a dragon through the intricacies of curling ornaments. Underneath the brim of the cup runs an inscription in pseudo-Arabian letters, and at the bottom of the cup is engraved: *Magister: G. Alpaïs: me fecit: Lemovicarum (Limoges.)* This scyphus is thirty centimeters in height and fifteen in diameter.

Let us now examine how the gold and silversmiths of that time managed the most important part of their work—I mean chasing and repoussé.

WALTHAM

NEW MODEL

16 SIZE HUNTING PENDANT SETTING

“ROYAL” MOVEMENTS

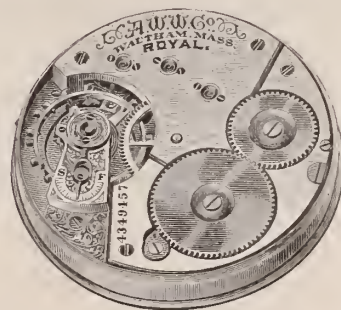

NOW ON THE MARKET.

In this treatise on the matter, Benvenuto Cellini exposes the method employed by his master, Caradosso, and then describes his own way of doing it. The great artist especially dwells on alto-relievo work, and, being partial to figures, explains the different processes of shaping them in gold and silver.

When Caradosso had to make a gold figure of Christ, he first carefully modelled it in wax, next covered it with several coating of a muddy substance, with the help of a brush, and finally put sand over it. This was the usual process for *cire perdue* casting. The pieces was then exposed to heat, which caused the wax to melt down, and escape through various holes, pierced for that purpose at the bottom. Melted bronze was afterward poured into the mould thus obtained, and filling up all the hollows in it, assumed, in cooling, the exact form of the wax model. On that bronze figure, disengaged



FIG. 10. OPEN WORK BY W. A.

from its wrapper, Caradosso applied a well-prepared gold plate, and next with the help of hammers, mallets and various tools in wood and iron, gradually gave to this plate the shape of the model it covered. This required, of course, repeated annealing. When the alto-relievo was fully obtained, all accidental crevices were soldered and the bronze figure was removed. Then the gold figure was filled up with cement and the margins of the *coquille* stamped work were well joined together at the back, and all the details finished off with a *ciselet*. Finally the cement was driven out and the holes, which had been left on purpose for it were closed with solder.

(To be Continued.)

PINE BLUFF, Ark.
I do not want to miss any copies.
SIDNEY SMITH.

<p>***</p> <p>JAS. W. MILLER,</p> <p>MANUFACTURER OF</p> <p>FINE • GOLD • JEWELRY</p> <p>***</p>	<p>SUCCESSOR TO MILLER BROS. & Co.</p>
<p>37 UNION SQUARE,</p>	
<p>INITIAL GOODS A SPECIALTY.</p>	<p>NEW YORK.</p>

WATCHES

JOHN B. YATES,

147 NASSAU STREET, NEW YORK.

Specialty: UNITED STATES WATCHES.

The Patent O. F. Cases have these Advantages over the Regular Case: It is Dust Proof and Decidedly Cheaper.

B.W.C. CO.
14K

EXAMINE THIS

NOVELTY IN 14-K.

O.F. DUST BAND.

THE BROOKLYN WATCH CASE CO.

192 Broadway, New York,

HAVE IN STOCK AND FOR SALE BY ALL JOBBERS

❖ 14-K. Brooklyn Eagle Wheat and Granger ❖

GOLD CASES IN 18, 16, 6, 14 AND 0 SIZES ADAPTED TO ALL MOVEMENTS OF THE ELGIN MODEL.

TRADE GOSSIP

La Secla & Lowy have succeeded La Secla & Schoenbein, 93 and 95 Green street, New-N. J.

Ehrlich & Sinnock have succeeded Ehrlich, Heinz & Sinnock, 231 Mulberry street, Newark, N. J., Mr. Heinz retiring.

The Field Manufacturing Company, No. 250 Commerce street, San Antonio, Texas, opened a diamond business on January 28.

William Goldstein, formerly with M. Bonn & Co., is now on the road for Kingsbacher Bros., Pittsburgh, Pa. His many friends wish him success.

Caney & Bradley, of Buffalo, N. Y., jewelers, dissolved partnership, on Feb. 1, Mr. Bradley retiring. Ashton W. Caney will continue the business.

D. De Soia Mendes & Co., 49 Maiden Lane, New York, have issued a very useful and convenient article in the shape of a card-board diamond price list.

S. Valfer & Co., 66 Nassau street., New York, are producing some new designs in jewelry cases and trays. Samples will be furnished upon application.

E. J. Hertz, formerly with H. Muhr's Sons, opened on Monday, last, a fine line of diamonds, watches, jewelry and silverware at 726 Chestnut street, second floor.

In accordance with their notice of Oct. 1, the New York Standard Watch Co. have advanced the price of their seven-jeweled movement, nickel or gilt damaskeened, from \$3.50 to \$3.75.

R. Blackinton & Co., North Attleboro, Mass., have completed for the spring trade a very large line of fleur-de-lis brooches in silver and rolled plate, all in their superior style of design and finish.

The demand for the "J. G. C. & Co.," rolled plate chains, made by J. G. Cheever & Co., North Attleboro, Mass., was never better than it is at present;—a reliable article made by a reliable house.

Williams, Brown & Earle, Nos. 33-39 South Tenth street, have imported for a customer the most powerful and expensive microscope ever brought to this country. It is valued at \$1,600, and magnifies from power 12 to power 25 50

Maxheimer & Beresford, 3 Maiden Lane, N. Y., make a specialty of fine diamond order work. They are both practical jewelers and can therefore ensure the prompt and satisfactory execution of the most difficult orders.

Lawson & Van Winkle, 11 Maiden Lane, N. Y., show a very fine line of "heart" jewelry in moonstone, turquoise, rosaline, garnet, etc., mounted in gold and silver. Their goods are all tasteful in design and carefully finished.

HEADQUARTERS FOR

14-K. BEAD NECKLACES, GOLD JEWELRY,

— AND —

Krementz One-Piece Collar Buttons.

KREMENTZ & Co.,

MANUFACTURERS,

182 & 184 Broadway, NEW YORK.



Fine Commercial and Copper-Plate Printers.

A Specialty of

Jewelers' Printing, Cuts and Electrotypes.

Headquarters for JEWELERS' CARDS.

BEST WORK.

PROMPT DELIVERY.

LOW PRICES.

No Order Too Large! None Too Small!

146 Westminster Street,

PROVIDENCE, - RHODE ISLAND.

PETER HENRY,

MAKER OF

Special Watch Cases

For American, English and Swiss Movements,

No. 56 Longworth Street,

Room 4, Second Floor, CINCINNATI, O.

Key Winders changed to Stem Winders.

English Cases changed to fit American Movements.

Hunting Cases changed to Open Face.

Old Watch Cases Reconstructed, Repaired and Renewed.

LOW PRICES, GOOD WORK AND PROMPT ATTENTION GUARANTEED.

ONE OF THE OLDEST RESTAURANTS
DOWN TOWN.



POPULAR PRICES

JOHN A. RILEY,

860 Broadway, New York,

MAKER OF

Hair Pins, Plain and Gemmed, Grecian Fillets,
BROOCHES HAT PINS
BRACELETS QUEEN CHAINS
SCARF PINS SCARF HOLDERS.

"The Ryder & Dearth Co.," is the way the sign of the well-known designing and engraving establishment, at 146 Westminster street, now reads. The change to a limited corporation was rendered advisable by the rapid growth of business.

Lewis DE Goll, agent of the Roy Watch Case Co., 17 Maiden Lane, has just returned from a successful trip through the West with their new line of samples. He reports a specially brisk demand for their new patterns in raised gold ornamentation.

T. B. Clark & Co., cut glass manufacturers, Honesdale, Pa., have recently completed a commodious new factory for the better accommodation of their business. It is one of the largest glass-cutting shops in the country, having a capacity of 120 frames.

The growth of the business of Koch & Dreyfus, 22 John street, continues unabated, what with the very efficient office management of the members of the firm, ably seconded by their corps of five travelers who penetrate into nearly every corner of the land.

During the recent shut down at the factory of Frank W. Smith, Gardner, Mass., a good deal of new machinery was added in preparation for the increased business of the coming year. Mr. Stone, foreman of the hollow-ware department, has been absent in Europe in search of new ideas.

Parties in the trade desiring special dials of any kind, either for clocks or watches, should recollect that a fully equipped dial

factory is now in operation at Waltham, Mass. The Waltham Dial Co. guarantee the prompt and satisfactory performance of all such orders entrusted to them.

The Pairpoint Mfg. Co., New Bedford, Mass., keep themselves ever before the trade, both by the variety and novelty of their productions in silver plate, and by the liberal use of printers' ink. This time it is a handsome calendar that reminds the trade of the eternal vigilance of the Pairpoint Co.

A. J. Logan, Waltham, Mass., is having considerable success with the "Little Giant" screw-driver he recently placed on the market. It has four blades fitting into one holder, easily changed, and held securely in place. He has also made some desirable improvements on his well-known upright jaw gauge.

The Empire Plating Works, 75 Nassau street, New York, have prepared a neat little price-list which they will forward upon application. The prices appear very low, when we consider the excellence of their work. Gold and silver plating, Etruscan coloring, polishing and refinishing of old stock are the specialties of this concern.

Ludwig Nissen & Co., 18 John street, New York, made a big hit last season with their magnificent line of rich diamond pendants, brooches and rings. They have the courage as well as the taste to mount up the most expensive work, and there is something in it besides gold and diamonds, for it sells, and readily too. Messrs. Nissen & Co. are in the

line of progress and will show a stock this year that will outshine all their previous exhibits.

ONE of the largest and finest lines of bronzes manufactured in the country is that of the Muller Bronze Co., whose works are in the Shiebler Building at the corner of Underhill and St. Mark's avenues, Brooklyn, N. Y. All the prominent jobbers are handling them. The goods are excellent in design, workmanship and finish, and are especially adapted to the clock and jewelry trade.

Jewelers are reminded that when they are asked for badges and medals for societies, or for presentation, or for pins or rings for classes in schools, that E. R. Stockwell, No. 19 John street, New York, has all facilities for the production of such work either in gold or silver, as also for the satisfactory performance of enameling, engraving, encrusting and all kinds of order work or repairing for the trade.

HENRY C. HASKELL, 192 Broadway New York, has just issued three new sheets which display numerous new and original designs in silver and gold class and fancy rings. These sheets which Mr. Haskell has been issuing for some time are copyrighted and prove very useful to the retail jeweler; they will be furnished up on application. Mr. Haskell designs all the goods he manufactures and has become widely known and appreciated by his fertility in this line of work.

A. WITTNAUER,

Successor to J. EUGENE ROBERT & CO.,

NO. 30 MAIDEN LANE, NEW YORK,

MANUFACTURER AND IMPORTER OF

WATCHES AND WATCH MOVEMENTS.

AGASSIZ

AND

LONGINES

MOVEMENTS,

FITTING

6, 16, 18 Size Cases, in 3 Grades.

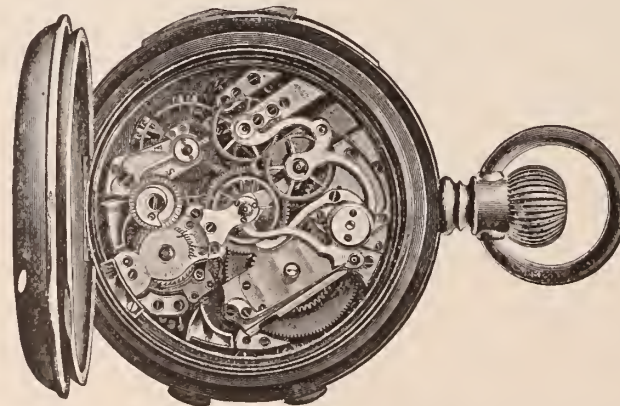

SOLE AGENTS FOR

LOUIS AUDEMARS

AND

JULES MONARD,

GENEVA

Unexcelled Timekeepers.

CHRONOGRAPHS, SPLIT SECONDS, MINUTE REPEATERS, &c.

16 and 18 Size Movements, Open Face and Hunting. Thoroughly Adjusted for Accurate Time and Railroad Use.

Levy, Dreyfus & Co., importers of materials and optical goods, 11 Maiden Lane, New York, are increasing their optical department, particularly in the line of spectacles, notwithstanding the recent addition of a department of French clocks and bric-a-brac. They have in their employ a number of graduates of optical schools, who are thoroughly competent to give instructions to customers desiring it.

The watch and clock oils made by Wm. F. Nye, New Bedford, Mass., are becoming so generally known and prized that further comment is hardly needed. But there is one point in their favor that deserves special mention, and that is, their non-susceptibility to extreme cold, the severest test to which a watch oil can be put. A testimonial published on another page, should be read by every watchmaker.

The extensive cut glass showrooms of C. Dorflinger & Sons, 36 Murray street, New York, are now restocked after the heavy inroads of the holiday trade, with the largest assortment of fine cut glass ware to be found in any establishment of the whole country. Among the patterns worthy of special mention are a number entirely new, which must be seen to be appreciated. Jewelers do not need to be told the way to the Dorflinger establishment.

Hutchison & Huestis, the well known ring makers, 185 Eddy street, Providence, are most painstaking in their efforts to keep before the trade only the newest and most salable patterns in fancy stone rings. They are continually culling out the least desirable goods and substituting them with fresh and attractive designs. The consequence is they are able to show an array of patterns that is sure to satisfy all shades of taste and opinion, and in point of average excellence is unsurpassed.

A new candidate for the favor has appeared—"The Sun" interchangeable initial ring made by Julius Wodiska & Co., 49 Maiden Lane, N. Y. The initial is held securely in place by a disc turned by means of a simple little tool furnished by the manufacturers. The advantages are simplicity and ease of adjustment. The style of advertising adopted by the firm is as novel as the thing advertised, and will attract the attention it deserves. Retailers should order samples of their jobbers.

The Spencer Optical Manufacturing Co., 15 Maiden Lane, New York, after the most successful year of their career as manufacturing opticians, are preparing themselves this year for still greater achievements. This company are fully awake to the needs of the trade, and are abreast with the demands of the times, both as to the quality and prices of their goods. They commence the new year with an extensive and varied line of spectacles and eye glasses, over 400 samples being shown. Their three new trade-marked spectacles and eye glasses, the "Audemar," the "Achronia," and the "Le Roque" deserve the attention of every optician and jeweler.

Hennege, Bates & Co., of Baltimore, Md., is an old and popular jewelry house and one that displays great success in holding the Southern trade. This success is attributable to liberality and the practice of the golden rule. The active operation of these two principles, coupled to vigor and enterprise, are bound to secure the success of any business house. The business done by this firm in 1890, it is said, and especially that of December, is far ahead of that done in the same periods in any previous years.

M. Zineman & Bros., optical dealers, 130 South Eighth Street, Philadelphia, are prepared to fill all orders for artificial eyes, having secured the American agency for Mueller's celebrated make, Thüringen, Bavaria. Dealers will find it an advantage to test the facilities of this firm in this line. The Messrs. Zineman are well known for their enterprise, and they have embarked in the artificial eye business on an extensive scale. The popular "Diamanta" spectacles will still be the leading specialty of this house.

L. Tannenbaum & Co., importers and cutters of diamonds and precious stones, 65 Nassau street, New York, have probably the most extensive stock of these goods to be found in the market. Anything in the line of fancy stones, rubies, sapphires, emeralds,

opals, moonstones, etc., both rare and staple, can be found here for all uses and requirements. This firm also runs an extensive lapidary establishment, cutting for themselves and for the trade. A number of exceptional bargains are now offered, which will well repay inspection.

The following letter in reference to the Clark Comparative Gauge, of which Nordman Bros., 120 Sutter street, San Francisco, Cal., are the sole agents for the United States, speaks for itself:

E. CLARK, ESQ., *Dear Sir:*

After using your Comparative Gauge for several months in the Otay Watch Factory, I take pleasure in recommending it to the trade, as being the most perfect gauge for measuring all parts of a movement I have ever seen. Its jaw measurements being in 1,000ths makes it easily understood by all, twelve pennyweight being its net weight makes it practical for use on the lathe for gauging lengths.

For gauging strengths for hairsprings it has no equal. For gauging wheels, pinions, mainsprings, wire, etc., it will be easily appreciated by all as it is instantaneous in all measurements.

P. H. WHEELER,
Supt. Otay Watch Factory,

Worcester & McDonald, electro platers, 120 Friendship street, have bought out the plating business of G. L. Greene & Co., Friendship street, and will amalgamate it with their own. Their new process of electro plating by anodes is being rapidly introduced into the watchcase and jewelry factories of



FLEUR DE LIS BROOCHES.

ALSO A FULL LINE OF

STERLING :: SILVER :: JEWELRY,

INCLUDING

Love Locketts, Brooches, Lace Pins, etc.,

And also in first quality Rolled Plate.

R. BLACKINTON & CO.,

New York Office,

No. Attleboro,

182 BROADWAY,

MASS.

J. R. MORSS.

HENNEGEN, BATES & CO.

BALTIMORE, MD.,

Manufacturing Jewelers,

DIAMOND IMPORTERS

AND JOBBERS

IN ALL GRADES

AMERICAN WATCHES.

GOLD, SILVER AND NICKEL CASES.

Cor. Baltimore and Charles Streets.

the country, and everywhere with the most signal success. It is cheaper, quicker and better in every way than the old method by solution, and needs but to be tested to be approved. They sell the apparatus necessary to perform the work, and put it in thorough working order for their patrons.

THE Trenton Watch Co. have placed on the market a new model eighteen-size jeweled nickel, stem wind movement, in both open face and hunting cases. This movement is new in construction throughout and possesses several new features which will prove advantageous to the retail jeweler. In the company's advertisement on another page illustrations of this movement are given. The open plates display the train and the Damaskeen patterns are very attractive. A novel feature and one that is appreciated by the watchmakers is that the barrel can be removed without disturbing the train or stem-winding parts. The movement is offered at a very low figure. The factory at Trenton, N. J., is furnishing 200 movements per diem, and everything points to an increase in this output.

The word "Seamless" has a talismanic power in the trade to-day. It can safely be said that the most popular rolled plate chains to-day are those made with wire prepared according to the ingenious process described by the above word. The merit of introducing this valuable improvement in chain-making to the jewelry trade of the country belongs pre-eminently to Kent & Stanley, the enterprising chain house, 7 Eddy street, Providence. Recognizing the value of the Burdon invention and its availability for the manufacture of plated chains, this house took hold of it and pushed it with characteristic vim and determination. The result is that to-day the "Seamless" chains are known to every jeweler in the land for their novel mechanical construction and superior finish. An enormous increase of business has followed the popularization of these goods, taxing Kent & Stanley to the utmost to keep the trade supplied, and the better to supply the demand the manufacturers have decided to make all their chains of Burdon seamless wire henceforth, and for the protection of themselves and their customers they have

adopted a trade-mark to signify that all their chains are made of Burdon seamless wire. Striking cuts of this trade-mark will be found on two of our advertising pages.

Three Jewelry Firms Burned Out.

PROVIDENCE, R. I., Jan. 31.—A fire started from a gas oven just before four o'clock this morning in the five-story brick building, corner of Stewart and Conduit streets, owned by S. & B. Lederer, and occupied by them and two other jewelry firms. Royce, Allen & Co. lost about \$10,000; insured for \$17,000, and B. Lederer lost about \$20,000; insured for \$25,000, and \$10,000 of stock, covered by insurance. D. F. Adams lost about \$15,000; insured for \$10,000. Two hundred and fifty persons were employed in the building.

As Usual.

BRQOKLN, N. Y., Feb. 7, 1891.

The various letters duly received. You may discontinue the advertisement. The results of this ad. far exceeded a trial in another paper.

O. P. LOOMIS.

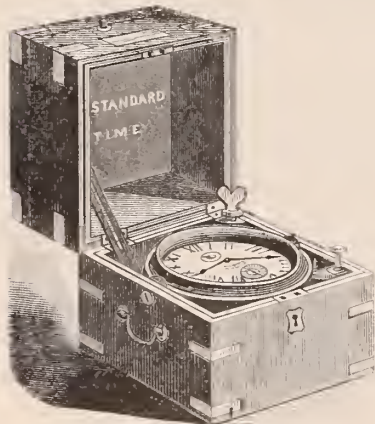

TO WATCHMAKERS.—We have on hand a number of Chronometers, by various good makers, not new, which have been in service for purposes of navigation, and are excellent instruments. They come to us by reason of the great decline in American shipping. They have been put in perfect repair, and will give satisfactory results as to performance. We will sell these chronometers at low prices, either for cash, or on accommodating terms to suit special cases, or will hire them at moderate rates, and allow the hire to apply on purchase. **Send for Circular giving prices and terms.**

Our Watchmakers' Transits are readily set in position. Printed instructions, easily understood, accompany each instrument, and no preliminary calculations are required. With them correct time can be obtained within one second.

JOHN BLISS & CO.

Manufacturers of Marine Chronometers,
128 Front Street, New York.

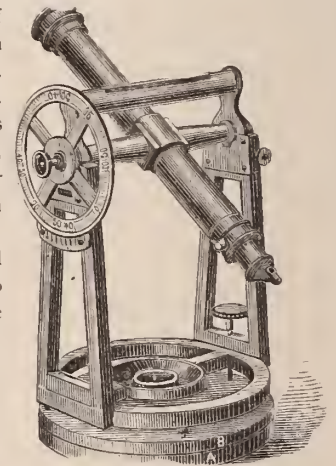

W. E. W. & CO.

Manufacturing Jewelers,

54 PAGE ST., PROVIDENCE, R. I.

OUR FINE Line of Gold Goods this season includes Bead Necks in ten and fourteen carat, Scarf Pins, Drops, Jersey Pins, Dress Sets, Rings and Bracelets, Band Bracelets in Plate, and the celebrated POMHAM Collar Button. To these has been added a full line of White Stone Goods in Gold for the Spring Trade. It should be remembered that OUR GOLD BEAD NECKS ARE THE LIGHTEST MADE. Ask to see them.

SELL TO JOBBERS ONLY.

W. E. WHITE & CO.

NEW YORK OFFICE, 26 MAIDEN LANE.

S. A. BALDWIN.

A Wonderful TOOL FOR THE BENCH.

Instantaneous in Its Work!



Dividing the inch into one thousand parts. A most practical tool for watchmakers for gauging from a hair-spring to a main-spring. Non-comparable for a height and depth gauge. Instantaneous for hair-spring work.

For sale by all Jobbers.

NORDMAN BROTHERS,

120 Sutter St., SAN FRANCISCO, CAL.

Sole Agents for the United States.

News Gleanings.

Marck Bros., of Warren, Pa., carry solid gold and silver goods exclusively.

McVicar & Robinson, of Eric, Pa., report an unusual sale of watches during the past year.

A cut of 10 per cent. has been made in all the departments at the watch factory at Rockford, Ill.

T. A. Robinson, of McVicar & Robinson, the Park Row jewelers, is seriously ill with typhoid fever.

The sheriff has taken possession of the stock of H. B. Johnson, jeweler, at Marinette, for the benefit of creditors.

All the prominent jewelers of Erie city, have signed the early closing movement which goes into effect soon.

Mr. A. Bening, Roanoke, Va., has fully recovered from his recent spell of sickness and is busily engaged at his place of business.

Mr. John Inglis a prominent jeweler of Northeast, Pa., is enjoying an extended tour through the Southern States. He is at present in Florida.

The early closing association, organized by the clerks of San Francisco, will compel its members to hereafter wear a badge in the shape of a silver button.

Royal E. Robbins, Treasurer of the American Waltham Watch Company, has been made assistant treasurer of the Republican Ward and City Committee of Boston, Mass.

A New Castle Pa., jeweler has sold to the Rev. C. H. B. Turner, of Tyler, Texas, a large clock which belonged to Cæsar Rodney, one of the signers of the Declaration of Independence.

Willis D. Upson, proprietor of a jewelry store in Waterbury, Conn., was fined \$20 and costs on February 3, for expectorating tobacco juice on the windows of a rival establishment.

Ferdinand Berthoud's watch case manufactory at Milford, Pa., was recently sold out by the sheriff, P. J. Jirard, for some years connected with the concern, buying in the business, which is now carried on under his name.

The estate of A. F. Burbank, dealer in jewelry and sporting goods, Worcester, Mass., suffered a loss by smoke from fire in the building they occupied of probably \$1,000. The damage done to the building was about \$200. There is a full insurance.

J. B. Stevens & Brother, jewelers, of Atlanta, Ga., offer a prize (a diamond set badge, bearing the emblem of the S. T. A.) to be given to the most popular member of the Southern Travelers' Association on the occasion of the annual convention in May.

While Henry Reese was tearing down an old log stable on his farm, west of Connersville, Ind., about four miles, he found stowed away a jewelry case containing a lady's gold watch and chain, pair of bracelets, breastpin and ear-rings all in good

state of preservation. They were of an old style and costly, and had probably been there for years.

I learn that the watch factory at National City, the first and only institution of the kind on the Pacific coast, is soon to be revived. The San Francisco office has not been discontinued, and at a meeting of the stockholders, held in National City on the 20th, it was arranged to continue with the factory. About twenty-five persons were formerly employed at the works, and they have been forced to lay idle.

The P. S. Bartlett jewelry store has been purchased by Thos. Evans of Chicago and John L. Davery, of Elgin. The new firm of Evans & Davery combine the experience of age and the vigor of youth. Mr. Evans has had a life-long experience in this business. For ten years he was Western manager of the Dueber Watch Case Company, with headquarters in Chicago. He is entirely conversant with all the details of the trade and is well known as a man of sterling business principles.

Wm. Tinthoff, an old-established jeweler of Oil City, Pa., recently utilized the many years' accumulation of trinkets and odd pieces in his establishment, by decorating a rose jar. The body of the jar is completely covered with small articles of jewelry of every description, set into the clay in odd and interesting designs, and gilded over. Some of the ornaments have been out of date for twenty years. A neat little clock set in the side keeps good time, while a watch case set in on the opposite side opens to permit the winding of the clock.

Solomon Loeb, a prominent jeweler of Erie, Pa., has recently erected, and is soon to occupy a handsome and commodious three-story building on the east side of State street, near Tenth street. It will have one of the largest and most elegant store rooms in that part of Pennsylvania, and will be occupied exclusively by Mr. Loeb. The building is 28x100 feet, very substantially constructed of brick and stone with terra cotta front. The salesroom is 24x60 feet, beautifully decorated and finished, and furnished in antique oak. There is a vault for two large safes, and back of the salesrooms two convenient work-rooms. Either Mr. Loeb or his son will soon start for New York to purchase a large and complete stock of goods.

It Will be Higher.

SUNBURY, Pa., Jan. 22, 1891.

If in your new departure of publishing weekly instead of monthly the standard of THE CIRCULAR is to be maintained as it has been in the past, I never want to be without it.

W. H. HILL.

WESTERLY, R. J. Jan. 24, 1891.

We are pleased to note that your visits are to become weekly instead of monthly, and rest assured we appreciate your endeavors to make THE CIRCULAR the leading organ of the kindred trades.

E. N. DENISON & Co.

CROSS & BEGUELIN,

21 MAIDEN LANE, N. Y.



The Old Reliable CENTENNIAL.

Best Nickel Watch Made.

OVER 325,000 IN USE.

Jobbers of all American Watches. ❖ ❖

❖ ❖ Gold and Rolled Plated Jewelry.

WATCH TOOLS, GLASSES, Etc.

SEND FOR PRICE LIST.

ATTENTION!
ALEX. WIEDERHOLD,
20 MAIDEN LANE, N. Y.,
Repairing Jeweler.

Jobbing sent to me by mail or express will be repaired and returned promptly. Prices Moderate and First-class Workmanship Guaranteed.



HEARTS.

MOONSTONE,
TURQUOISE,
HEMATITE.

GARNET,
ROSALINE,
CORAL.

Mounted in

GOLD and SILVER

BONNET PINS AND BROOCHES.

Lawson & Van Winkle,

11 Maiden Lane, NEW YORK



RESPONSIBILITY OF MAKER OF NOTE WHO SIGNS
ONLY AS AN INDORSER.

Where a note is signed by a third person before delivery, in order to give the bank at which it is discounted the security of two names as required by its rules, with the intention of assuming the character and the liability of an indorser and not the maker, his liability is that of an indorser and he is entitled to notice of the dishonor of the paper, although the maker and the bank understood that his liability was that of a surety.

ASSIGNMENT OF LIFE INSURANCE POLICY FOR
BENEFIT OF CREDITORS.

Where a debtor takes out a policy of life insurance and after holding it a short time, in good faith transfers it by indorsement to some of his creditors, taking from them an agreement under which they were to pay the premiums, and from the proceeds of the policy retains the amount of their claims and pays over any surplus remaining to his heirs, such a transaction is not in fraud of creditors not participating, and is valid and will be sustained.

INJURY OF GOODS SHIPPED "RELEASED."

In a suit against a common carrier for breaking merchandise shipped "at owner's risk of breakage," the plaintiff has the burden of proving that if the freight was received in good order, and by the exercise of ordinary care could have been carried and delivered in like good order, then the law presumes that the breakage was caused by the carrier's negligence. The only liability of a railroad company for goods shipped released is for injuries sustained through the actual negligence of employees of the company. Upon release the shipper assumes the ordinary risks of transportation.

NEGOTIABILITY OF NOTE PAYABLE "ON OR
BEFORE" SPECIFIED DATE.

The rule that negotiable notes when transferred before maturity shall be subject to no defenses arising out of the transaction, is founded upon the principle that a negotiable note is an unqualified promise to pay a certain sum at a certain time, and while it has been contended that a note due "on or before" a certain date, being uncertain as to the time of payment, was therefore removed from the operation of the law of negotiability; but, the object of the rule is to fix a certain time at which the money must be paid, and an "on or before" note does that. So that the fact that it may be paid before the day fixed cannot be said to prejudice the holder or affect the certainty of the time at which it must be paid. Therefore such a note is held to be subject to the rules of negotiability.

Copyright, 1890, Law News Bureau.

CHICAGO WATCH TOOL CO.,

52 MADISON STREET, CHICAGO, ILL.,

MANUFACTURERS OF

Staking · Tools, · Foot · Wheels, · Polishing · Lathes

AND ALL KINDS OF

WATCHMAKERS' AND JEWELERS' TOOLS.

Catalogues sent upon application.

ESTABLISHED 1863.

J. BECK & SON,

MANUFACTURERS OF

Solid Gold and Silver Chains, and Jewelry,
NO. 10 LIBERTY PLACE.

Near Maiden Lane,

NEW YORK.

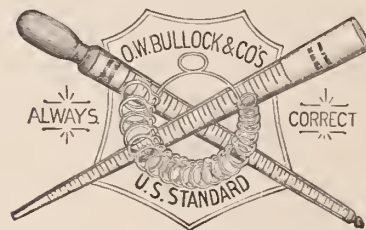

"GET THE BEST."

American Tools are the Best.

O. W. BULLOCK & CO.,

Springfield, Mass.

Manufacturers of WATCH TOOLS.

LARGEST LINE IN THE UNITED STATES.

Send 4 cents for postage on new catalogue.

WILLIAM B. DURGIN

Designer and Maker of Wares in

STERLING · SILVER

SPECIALTY OF

Plain and Fancy Flatware

CONCORD, N. H.

LARTER, ELCOX & CO.

MANUFACTURERS OF

SNAKE RINGS, White Onyx Link Buttons,

LADIES', GENTLEMEN'S AND
CHILDREN'S RINGS.

ALSO NEW PATTERNS IN

THE PATENT SPRING BACK STUDS.

FACTORY, NEWARK, N. J. + + OFFICE, 41 & 43 MAIDEN LANE, N. Y.

The Jewelers' League.

THE first meeting of the new Executive Committee of the Jewelers' League for the current year was held at the League office on Friday afternoon February 6th.

There were present President Hayes, Vice-Presidents Bowden and Greason and Messrs. Jeannot, Howe, Untermeyer and Sexton.

The meeting was called to order by the Secretary and upon motion of Mr. Hayes, seconded by Mr. Untermeyer, Mr. Geo. R. Howe was nominated and unanimously elected Chairman of the Committee for the present year.

There were five requests for change of beneficiary granted; one application for membership was referred for investigation, and the following applicants were accepted:

- Wm. L. Slade, Attleboro, Mass., recommended by E. C. Glines.
 Leopold Stern, New York City, recommended by J. J. Cohn and B. Spier.
 D. B. McLintock, New York City, recommended by Geo. C. Booth and J. L. Fowler.
 H. R. Ingram, New York City, recommended by Frank M. Welch and W. R. Ailing.
 W. F. Chambers, New York City, recommended by W. Hunter Brown.
 H. E. Perkins, Binghamton, N. Y., recommended by W. J. Eroe.
 C. E. Adler, New York City, recommended by A. A. Reeves and C. A. Boynton.
 S. F. Smith, Huntsville, Ala., recommended by J. W. Steele.
 Geo. C. Child, Philadelphia, Pa., recommended by A. K. Sloan and G. H. Hodenpyl.
 J. E. Bailey, Philadelphia, Pa., recommended by J. B. Sanford and G. H. Hodenpyl.

- L. Tannenbaum, New York City, recommended by Wm. Bardel and Henry Heller.
 H. Goldsmith, New York City, recommended by Wm. Bardel and Henry Heller.
 F. H. Fleischer, New York City, recommended by Wm. Bardel and Henry Heller.
 I. Harris, New York City, recommended by Wm. Bardel and Henry Heller.
 A. Lape, New York City, recommended by L. H. Mattison and J. H. Johnson.

Death by Apoplexy.

MELROSE, MASS., Feb. 3.—On Monday at midnight, Mr. Marcus A. Bush was found in his chair at his office on Essex street, evidently suffering from a stroke of apoplexy. Although physicians were immediately summoned, he expired in a few moments. Mr. Bush has resided in Melrose for many years, and for some time has carried on a watch and jewelry business. He was one of the heaviest men in the town and had previously suffered from apoplexy due to his weight and size. He was a member and officer of Trinity Episcopal Church, of Melrose Lodge of Odd Fellows, of the Order of the Golden Cross and other benefit orders. He was about 70 years old and leaves a son, and a daughter.

CHAMBERSBURG, Pa., Jan. 8, 1891.

The retail jewelers, it seems to me, owe more to THE JEWELERS' CIRCULAR than to all the other journals combined. The high standard reached and maintained by you in the past is a sufficient guarantee for the future.

GEO. W. LUDWIG.

Birmingham.

J. B. Brown, of Mt. Vernon, Ohio, has been engaged by Leo Schwab to take charge of his repairing department.

His section has just passed through a season of depression caused by the strike of all the coal miners throughout the mineral belt of Alabama, of which Birmingham is the centre. Naturally, as all industries here were affected by this great strike, it could not leave the jewelry business unhurt, more especially as it occurred during the jewelers' harvest time.

Birmingham is quite a railroad centre, and nearly all the lines running through have the watches of their employes inspected by jewelers here. As on most other railroads, so on these, employes can not use any but the adjusted grades, and the time system on the principal roads requires, besides the usual quarterly inspection, a weekly time comparison which is now very strictly enforced, and the liability of accidents on account of variations in watches is thereby lessened to a minimum.

Henry E. Drake, formerly extensively engaged in the jewelry business, has been engaged by M. A. Roger & Co.

James Swarthout, long with Fravre & La Wise, has started in business for himself on a moderate scale. He has secured a room at 142 West Water street.

ESTABLISHED 1841.

CARTER, SLOAN & CO.,

MANUFACTURERS OF

FINE JEWELRY,

15 MAIDEN LANE, NEW YORK.

A. CARTER, JR.
 A. K. SLOAN.
 C. E. HASTINGS.
 GEO. R. HOWE,
 WM. T. CARTER.



Factory, NEWARK, N. J.

GORHAM MFG. CO.

Silversmiths.

SOLID SILVERWARE.



OUR recently completed works at Providence, R. I., are regarded as the most perfect and extensive plant for the manufacture of Silver Ware in the world, and include all the latest improved machinery, much of it peculiar to this establishment. Our corps of employes outnumber any similar establishment in this country or in the world.

Its capacity is for two thousand employes, and we are enabled by these increased facilities in every department to produce unlimited novelties in our line. Our stock now contains the largest and most varied assortment of Solid Silver wares ever presented, and at no time has it been so complete and well filled with novelties from the most inexpensive to the most elaborate and artistic.

HOLLOW WARES.

Our lines of Silver Hollow Ware have been increased by entire new designs in TEA and TETE-A-TETE SETS, SUGARS and CREAMS, AFTER-DINNER COFFEE SETS, TURKISH COFFEE POTS, BERRY BOWLS and SALAD BOWLS.

TOILET GOODS.

We have prepared several new and complete lines of TOILET ARTICLES for the fall trade.

ECCLESIASTICAL DEPARTMENT.

We have enlarged this Department at our works and at Broadway and 19th st., and we are capable of entertaining propositions of any magnitude in this line, and carry an extensive stock for immediate purchase.

LEATHER DEPARTMENT.

Our LEATHER GOODS surpass any that are offered to the Trade, in style, quality, finish and design. The stock contains the newest novelties and in advance of any other lines presented.

Broadway and 19th St., New York.

GORHAM MANUFACTURING CO.'S BRANCH HOUSES:

9 Maiden Lane, New York, * * * * *

137 & 139 State Street, Chicago, Ill.

120 Sutter St., San Francisco, Cal.,

* * * 36 Avenue de l'Opera, Paris, France.

ALL communications should be addressed,

BROADWAY and 19th STREET.

Works: Providence, R. I.

THE JEWELERS' CIRCULAR AND HOROLOGICAL REVIEW.

PUBLISHED EVERY WEDNESDAY BY

THE JEWELERS' CIRCULAR PUB'G CO.,

AT NO. 189 BROADWAY, NEW YORK CITY.

Members of the American Trade Press Association.

A JOURNAL DEVOTED TO THE INTERESTS OF WATCHMAKERS, JEWELERS, SILVERSMITHS, ELECTRO-PLATE MANUFACTURERS AND ALL WHO ARE ENGAGED IN KINDRED BRANCHES OF INDUSTRY.

Terms of Subscription, Postage Prepaid.

	PER ANNUM
United States and Canada, - - -	\$2.00
To all Foreign Countries, - - -	4.00
Single Copies, - - - - -	.10

ADVERTISEMENT.

Business letters, drafts, checks and post-office orders should be addressed to THE JEWELERS' CIRCULAR PUBLISHING COMPANY, No. 189 Broadway, New York City.

Manuscript from any quarter containing news or discussion of any technical subject within the field covered by THE CIRCULAR will be welcomed. Matter received that proves unsuitable or unavailable will be returned if accompanied by the necessary postage stamps.

Our editorial columns will contain our own opinions only, and we shall present in other columns only what we consider of interest or value to our readers. Applications to print advertising matter as news will not be considered.

Advertising rates in THE CIRCULAR are lower, considering the number of tradesmen reached by its large circulation, than in any other jewelry journal.

Notices of changes in standing advertisements must be received one week in advance, new matter can be received up to Saturday.

VOL. XXII. FEBRUARY 11, 1891. No. 2.

Industrial Schools. IN another column we give a brief notice of the work done in the Empress Royal School of Horology at Karlstein in 1889-90. It is interesting and suggestive.

The subject of industrial training, taking into account the steady growth of competition both domestic and foreign, has on all sides assumed such a phase that it almost literally means that the tradesman shall either during the whole course of his life grovel in the gutter, or enjoy a life of comparative luxury and ease, because superiority in every branch of manufacture has become a question almost of life and death to both nations and individuals. With the demise of the old system of apprenticeship was born the need for industrial schools; for places where, under competent instruction, the boy and young man might learn a trade. This is denied him under the division of labor system practiced in manufactories, where a good workman in any one particular branch becomes, not a skilled mechanic, but simply a higher grade of laborer. But the need is recognized and hence the schools, horological, technical, textile, designing, mechanical.

Mr. D. H. Hopkinson, the founder of the THE CIRCULAR, so early as 1882 proposed the foundation of a horological school in this city. He was met with a lofty wave of the hand and an emphatic declaration that the success of such an undertaking was impossible. That it was not and is not impossible is evidenced by the thriving condition of no less than six such institutions in the United States to-day—and there is room for still more.

To Tax Peddlers

WE would like to call attention to a communication in another column, where our correspondent proposes that a bill which shall make provision whereby peddlers of jewelry shall be taxed, shall be submitted to the legislature. The suggestion is a timely one; already in the General Assembly in Massachusetts, Mr. Ives of Newport, Massachusetts, has submitted a bill as an amendment to a chapter of the laws of the State "To regulate and Restrain the Sale of Certain Goods by Itinerant Peddlers." In this bill are specifically mentioned, jewelry, optical instruments, eye glasses, table ware, and many other articles of the jewelry trade. It certainly appears unfair that regular merchants should pay the school and other taxes of the towns in which they are engaged in business, and which they help to support, apparently for the benefit of these tramp peddlers, who carry their wares on their backs, who have no recognized place of business, and who contribute nothing toward the support of commonwealths upon whose business they thrive. Placing it upon this basis alone, it seems just that such a law should be enacted, not only in Massachusetts, but in every other State of the Union; and when in addition it is remembered that these peddlers are irresponsible, and in many cases, dishonest persons, the necessity for such legislation seems imperative.

A Pleasant Banquet.

THE meeting of the Chicago Jewelers' Association, which took place last Thursday in the Auditorium at that city, was a pronounced success from a social standpoint, and was one of the most magnificent entertainments ever offered by the jewelers of the country. Around the festal board were gathered representative men from all sections of the United States, and during the progress of the gastronomical portion of the entertainment, mirth and jollity reigned and good fellowship was supreme.

The Auditorium was a marvel of beauty in its decorations. Every effect that æsthetic and artistic taste could accomplish or appropriate fancy suggest, was carried out in its decoration. Judging from the speeches, which were happy and felicitous, the scintillations from the ornamentations were by no means the only brilliancies of the occasion. Voicing the sentiments the jewelers of New York city, we congratulate the Chicago Association upon the successful effort and wish them many happy returns of this annual occasion.

Bankrupt Law.

THE letter which we publish on page 21 of this issue, concerning the Torrey Bankrupt Bill, will, we believe, be read with special interest by our merchants. It was written by a man who from personal experience knows whereof he speaks. The just and equitable measures proposed by this bill would seem to commend it to every one who will be affected by its passage. The most important point in the bill is that it declares for honest surrender of all the bankrupt's property to a trustee or assignee for the benefit of his creditors. His entire property will be distributed among his creditors, each one receiving a share proportionate to the amount owed him by the insolvent. When the debtor has delivered his property he shall be free from his indebtedness and be able to go into business again, a free man. Thus he will be able to give the community the benefit of his unhampered efforts, and be able to work better and more freely than he would were he cumbered by the old debts. It has been urged against this that it would be offering a premium on failure and lead to many bankruptcies and debts that would never be paid. But in every man, if he be a man, is the natural desire to possess property and to be independent of his fellow men. Besides, the law permits him to pay up his old debts, although it does not leave to his creditors the remedial measure of the law to enforce his liability.

A fair comparison of past failures will show the many unjust measures that have been adopted by creditors to obtain preference and to secure to themselves the major part of the bankrupt's property regardless of what may be secured by his other creditors; under the Torrey Bill this cannot happen, but a fair, pro rata adjustment is made for all. The Torrey Bankrupt Bill may have faults, but it has virtues that more than counterbalance these faults, and that will certainly tend to an adjustment of a bankrupt's accounts with far more satisfaction to his creditors than can be obtained under the present law.

A Culpable Clerk.

NEWARK, O., February 3.—Two sneak thieves last evening worked Mr. S. W. Sturtevant, the North-Side jeweler successfully. They engaged the attention of a clerk, who was alone in the store, and after getting on terms of easy familiarity, one walked behind the case to look at an article displayed in it. Both walked away and shortly afterward three diamond rings valued at \$350 were found missing. Telegrams were sent in every direction giving descriptions of the property and the thieves.

Who Owns Them?

OMAHA, Neb., Feb. 2.—John Nelson was arrested last night, charged with being a suspicious character. He was in a Farnam street pawn shop trying to dispose of nineteen diamonds. The arrest was made by detectives Horrigan and Ellis. Nelson is well known to the police as being an all-round crook and a well-known gambler.

New York Notes.

Keller & Untermeyer have secured a judgment against S. Zimmern for \$197.33.

The New York Jewelers' Union have been admitted to the Central Labor Federation.

J. B. Wood, buyer for Charles F. Wood, arrived from Europe on Feb. 4th by the *Teutonic*.

The Ansonia Clock Co. has been granted judgment against Nathan Bachrach for \$164.39.

The engagement of Isidore Stern, of Stern Bros., 42 Maiden Lane, to Miss Jennie Rosett is announced.

A judgment for \$539.83 in favor of the Derby Silver Co., is recorded against John M. Wilson.

H. Henrich has secured a judgment for \$553.17 against Geo. A. and Edmund C. Viemeister, Brooklyn, N. Y.

Franz Wacker, 158 Bowery, has had a judgment recorded against him for \$272.23 in favor of J. P. Kernochan.

G. H. Hurlbert, President of the Middletown Flute Co., Middletown, Conn., accompanied by his wife, visited the city last week.

Saunders & Ives have been granted a judgment against William H. Payne, of the defunct firm of Payne, Steck & Co. for \$114.72.

Edwin A. Thrall has been elected a director of the Aurora Grata Association, which own the Aurora Grata Cathedral in Brooklyn.

Sol. H. Veit has left Koch and Dreyfus, and with his brother Millard has started in business at 51 Maiden Lane, under the name Millard Veit & Bro.

L. Sauter has retired from L. Sauter & Co., 1 Maiden Lane. The business will be continued under the old name by Robert C. Stahl and Charles R. Jung.

C. A. Hamilton, treasurer of the Rogers & Hamilton Co., Waterbury, Conn., and of the Bridgeport Brass Co., Bridgeport, Conn., was in the city last week.

Mr. Camerden, of Camerden & Foster, is on his way home from Europe, but will return in seven weeks. He passes about half his time on the other side.

The contents of the jewelry store at No. 1,447 First avenue, belonging to Augustus Fouchs, was sold at sheriff's sale last Friday on an execution issued against him for \$2,018.

Barker & Co. the rubber goods house that for years has been a landmark of Maiden Lane were sold out by the sheriff on Feb 5th, under attachment and execution aggregating over \$46,000.

Miss Lotta Throsby, of Brooklyn, who was missing for some days and who was found to have eloped with and married a young Brooklynite, is the young woman who, three years ago caused the arrest of Edward Morro, of 116 Court street, for alleged misconduct, which case has never been settled.

Stephen Martin, "Diamond Dick" and Grace Cobe, jointly indicted for stealing \$12,000 worth of diamonds from Simpson, the pawnbroker, were on Friday committed to the Elmira Reformatory.

F. Jeandheur, Jr., 4 Liberty Place, has opened a branch of his gold and silver plating works at 93 Green street, Newark, N. J. This new establishment will be conducted under the name of Jeandheur Bros. Etruscan coloring, bronzing, oxydizing, satin-finishing and electro-plating of all kinds are this firm's specialties.

The action brought by R. A. Briedenbach, 26 John street, to reach the assets transferred by Goodman & Rosenberger, 34 Maiden Lane, to Leopold and Max Rosenberger, the Importers' and Traders' Bank and the Chemical National Bank was decided on February 2d in the Supreme Court before Judge Andrews, against the plaintiff, the complaint being dismissed.

Before May 1 Hartley & Graham will move from 17 and 19 Maiden Lane to 313 to 315 Broadway, taking the entire building now occupied by the Celluloid Novelty Co., the latter concern moving to a larger building at the corner of Howard street and Broadway. Hartley & Graham have been located at their present address since 1853 and until 1881 carried on an extensive jewelry and fancy goods business, in conjunction with their arms and ammunition departments.

The old firm of gold pen manufacturers, H. M. Smith & Co., 83 Nassau Street, was dissolved by limitation, Feb. 1, I. Augustus Noe retiring. The business will be continued under the same name by the remaining partners, Horace M. Smith, Horace R. Bateman and Chauncey N. Frazier. Mr. Bateman will as heretofore superintend the manufacturing and financial departments. Mr. Frazier will represent the firm in the West where he has been known for twenty years, and the senior partner will cover the city and nearby trade.

On Feb. 6 the firm of H. C. Hardy & Co., 30 Maiden Lane, was dissolved by limitation and a new limited partnership was formed under the same name Horace C. Herdy, of Nutley, N. J., Henry E. Ide, of 257 Hicks street, Brooklyn, John J. Heiser, of 1200 10th avenue this city as general partners, and Danford N. Barney, of Farmington, Conn., as special partner. The latter contributes \$75,000. The character of the business will be as heretofore namely, the importation purchase and sale, both on commission and on their own account, of diamonds, and the partnership expires Feb. 1, 1894.

On January 1, 1889, Goodman & Rosenberger found themselves completely insolvent with liabilities of \$104,000 and assets of \$20,000. They continued business until April 10, 1889. They were indebted to Leopold & Max Rosenberger to the amount of \$9,045.52 on their promissory which came due and payable January 4, 1889. On or about April 10, the firm transferred to the attorneys of the Rosenbergers, Fettrich, Silkman & Seybel, for the benefit of these creditors goods valued at \$9,038.72, which were sold at an actual loss of \$284.33; They also transferred to the Importers, and Traders', Bank goods valued at \$1,300, and to the Chemical National Bank goods valued at \$8,000. R. A. Breidenbach got judgment to the value of his indebtedness and receiving no property on the execution he brought suit to set aside these transfers upon the ground that they were fraudulent in view of the general assignment act which by the amendment of 1887, limited preferences to one-third of the assets, and he claimed that whether or no a general assignment had been made preference beyond one-third could not be given. In his decision, Judge Andrews held that as no general assignment had been made by the insolvents, they could transfer in payment of honest debts, property to the amount thereof. The plaintiff intends to appeal the case.

Continued on Page 61

DORFLINGER'S AMERICAN CUT GLASS.



The Finest Crystal, Plain and Cut, made in the World.



EVERYTHING that is
used in Glass, for
the Table.

Sells as well as Silver-
ware.

EVERY FIRST-CLASS JEWELER

C. DORFLINGER & SONS,

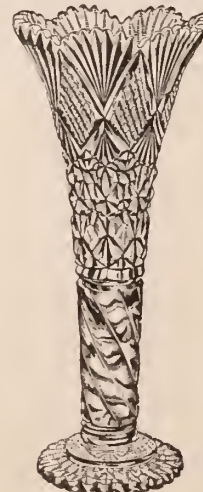

BEAUTIFUL, Artistic
and Useful Pieces
for Gifts.

Rivals the Diamond for
Purity and Lustre.

SHOULD KEEP IT.

36 Murray Street, New York.

Town Talk.

"THERE'S a demand for fine onyx," said Morris Klaber, who is one of the best judges of this mineral in the country, and a member of the firm of S. Klaber & Co., manufacturers of the finest art onyx goods, "and a pretty good sum awaits the man who discovers a deposit yielding blocks for manufacturing purposes. Scarcely a day passes without our receiving communications containing claims to discoveries, or without callers with specimens large enough to put in your pocket. But no large blocks of fine onyx have been shown."

"Our president reached the three score years and ten notch last week" said one man across the table, to his friend, "and we made him a beautiful present."

"What was it?" asked the friend.

"A fine rolled gold scarf pin with a fine karat diamond in the centre."

Do the laity know less about jewelry than about anything else?

"Yes," said the bedraggled citizen, "I am now indeed; but as there is no stagnation in this life, there must have been a time when I was different. And as I could not have been worse than I now am, I must have been better. Ay, indeed, I was better. Twenty years ago I was the proprietor of a prosperous jewelry business; I made considerable of my stock and carried a fine line of goods. I was a good-looking, pleasant fellow, I suppose, for my circle of friends was large, and upon it the greater part of my trade depended. I was of a musical turn and had a favorite song. Ah, I curse the day I sang it in the presence of my friends."

"Why should you curse it?" asked one.

"The song was the cause of my ruin."

"The song?"

"Yes. It was 'Silver Threads Among the Gold.'"

Fifty cents were collected in the hat that passed around.

Said an exporter: "There is a large trade in jewelry of every description to the Argentine Republic, precious stones, diamonds especially, finding a large market. The jewelry most salable is of 18 karat and 14 karat, France and Belgium supplying the bulk. German and United States rolled plate jewelry find a good market in the interior provinces. Germany, the United States and England supply the electro-plated ware. The importation of watches is of every variety, these articles coming from Belgium, France, United States and England."

A. N. CLARK, PLAINVILLE, CONN. } MANUFACTURER of the Celebrated

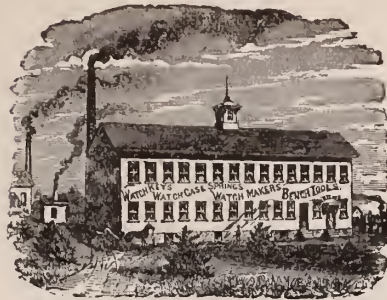

LOOP WATCH KEY.

The best for the price in the World. Size of Square stamped on each Key.

Also Key Rings, Watch Case Springs, Jewelry Tools, Tweezers, Etc.

SEND FOR PRICE LIST.

SOLD BY ALL JOBBERS IN THE LINE AT MANUFACTURER'S PRICES.

TO THE TRADE.

We beg to announce to the Jewelry Trade that we have opened at

No. 53 PARK PLACE, NEW YORK,

a Showroom for the display of our handsome line of

CUT GLASSWARE.

A full line of samples will be kept constantly on hand. Our latest design,

"THE AVON,"

is pronounced by connoisseurs the finest example of the art yet offered to the trade.

T. B. CLARK & CO., 53 Park Place, New York.

TOWLE · MFG. · CO.,

MANUFACTURERS OF



Sterling Silverware



NEWBURYPORT, MASS.: 214 MERRIMACK ST.

CHICAGO:

SAN FRANCISCO:

149 & 151 STATE ST.

220 SUTTER ST

OPPENHEIMER BROS. & VEITH,

Diamonds, Watches and Jewelry,

2 Tulp Straat,

35 Maiden Lane,

AMSTERDAM.

NEW YORK.

We beg to inform the trade that we are still in a position to fill orders for

✂ DUEBER HAMPDEN WATCHES ✂

Of all grades, from stock purchased previous to the closing of the factories at Canton.

IMPORTERS OF
DIAMONDS.

KOCH & DREYFUS,

22 John Street, New York.

JOBBER'S OF
Watches and Jewelry.

REPRESENTED ON THE ROAD BY

EMIL SCHORBACH, GEORGE MALLET,

HENRY HEYMAN, LEO GOLDSMITH.

GILBERT T. WOGLOM
BLACK MAKER OF Pearl Ornamented and Plain
JEWELRY. **ONYX**
GOLD MOUNTED.
32 & 34 John St. New York City.

ARTIFICIAL EYES!



STOCK ORDERS of
 Selection Packages.
 Largest Assortment.

GENEVA OPTICAL CO.,
 23 Washington St., Chicago.

S. COTTLE & CO.,
MAKERS OF
FINE JEWELRY AND SILVER NOVELTIES,
No. 86o Broadway, NEW YORK.

STOP!

A decorative feature in the Broadway store of the Gorham Manufacturing Co., is a cabinet presumably designed as a Roman arch. It is painted black, and contains two shelves besides a flooring. On the top shelf is arranged in the centre, a large ewer with small silver framed mirrors and silver-mounted cut-glass articles at the sides. On the second shelf are several cut-glass articles and mirrors. On the floor is displayed a large piece of silverware. A few incandescent lamps are arranged above the cabinet, and the light falling upon the bright, silver framed mirrors and diamond cut glass produces a glare that is dazzling. This small case seems to light up the whole space about it and attracts much attention.

The time is not far distant when lower Fifth avenue, that is, that portion of the thoroughfare from Fourteenth to Forty-second streets, will be the great retail jewelry district of the city. Union Square has been for years the seat of many of the finest establishments in the city; but in reality the west side of the Square is the only one which offers all the opportunities sought in conducting a large retail business. One of the largest establishments on the Square are contemplating a removal to Fifth avenue.

Geo. W. Washburn, of Sexton Bros. & Washburn, Oliver M. Ferrand, Irving L. Russell, Albert Creuze, S. & M. Blaise, and the late Joshua S. Cooley, all received a good part of their business training in the same house, Randel, Baremore & Billings.

Fine enamelled jewelry is becoming very fashionable, and many of the new flower brooches that are to be brought out with the first spring days will have their beauty enhanced in this way. Quite a revival is expected in floral brooches. These, during the winter, have played a somewhat subordinate part to the oblong, round and heart-shaped ones, with their amethyst and moonstone centres in gold settings of delicate workmanship. Enamelling is, however, by no means confined to the flower pins; it is also used on watch chains, pendants and chatelaines. Excellent effects are produced in Pompadour colors. A novelty in enamelled jewelry is a bracelet composed of a silver band overlaid with different colored enamels.

Louis XV. boudoir clocks are in accord with the present style of house decorations. Recently a fancy has appeared for French porcelain clocks of unique shape and peculiar decorations, for bedrooms. These clocks are usually accompanied by a pair of candlesticks to match. Novelties in clocks are those with tortoise shell, also crushed morocco cases. Crushed morocco, I will explain, is a new material for all sorts of fancy leather goods. It has a smooth, highly polished surface, produced by crushing down the natural roughness of morocco. The crushing process renders it more durable, and at the same time more costly. The present style of furnishing includes, for bedrooms and boudoirs, candlesticks to match the clock, whether the latter be of silver or porcelain.

OSTBY & BARTON,

SOLID GOLD BAND, STONE

- - AND FANCY RINGS - -



— ALSO A LARGE LINE OF EMBLEM RINGS. —

H. LUDWIG & Co.
MANUFACTURERS OF
NOVELTIES IN JEWELRY
LARGEST MFG. OF POPULAR PRICE JEWELRY IN U.S.

NEW YORK OFFICE,
 PRESCOTT BUILDING,
 ROOM 40. SAMPLES ONLY.

WORKS, BLACKSTONE & GAY STS.
TAKE PRAIRIE AVE CAR

Providence, R.I.

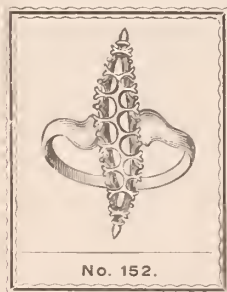

No. 152.

STERN BROTHERS,
"S"

A "NOVELTY" in Marquis Rings.

SEND FOR SAMPLE.

Manufacturers of Fine **DIAMOND MOUNTINGS.**

42 MAIDEN LANE, N. Y.

DIAMOND SETTINGS. GALLERIES. HOLLOW BALLS, ETC.

BLANCARD & CO.,

36 & 38 JOHN STREET,

SEND FOR OUR

NEW YORK.

CATALOGUE.

Jewelers in Litigation.

PROVIDENCE, Feb. 5, 1891.—The case of Elizabeth T. Jones against Henry T. Salisbury was before Justice Tillinghast in the Court of Common Pleas, Tuesday. This is an action of trover and conversion to recover the sum of \$393, the value of some jewelry, tools, stock, etc., alleged to have been converted by Mr. Salisbury to his own possession in 1889, left for sale at an auction room in Attleboro, Mass., and subsequently brought back to this city by defendant. The defendant alleged that he had a mortgage on the goods in suit and that the plaintiff finally arranged to have them sold by an auctioneer in this city so as to pay the mortgage, if possible; Mrs. Jones, however, took away a portion of the property. The mortgage was for \$230, and Mr. Salisbury claims he helped the plaintiff with about \$170 more and has not been able to make himself whole from the proceeds of the sale. Held for advise-

In the same court on the same day the case of George Price against Charles W. Preston, was called. It is an action of trover and conversion to recover the value of certain brass castings and other materials intrusted to the defendant by the plaintiff to be manufactured into clock pendulums; after which he refused to complete the job or return the stock, which was valued at \$35. The defendant claimed that his contract was to make 100 clock pendulums, for the manufacture of which the plaintiff was to furnish certain portions of the stock, the job to be completed within a limited time. In the supply of the stock delay after delay occurred, and the defendant was kept waiting upon Price's failure to furnish material, until some months after the stipulated time, he having, meantime carried the work as far as possible without the lacking material, when he concluded an engagement to serve a corporation in another State within a limited time, and therefore gave plaintiff notice to provide the required stock at once. Price failing to do this, Preston declared the contract off and claimed compensation for the labor and the portion of the stock employed; and the plaintiff failing to adjust the matter, the defendant held the material in process, as security, claiming a lien thereupon. A verdict was found for the plaintiff for \$35.

Faber Bros. Assign.

DALLAS, Texas, January 27.—Late last night the Faber Bros. Jewelry Manufacturing Company made a trust deed of all their stock, furniture, etc., to satisfy creditors. The deed was made to John Alcott, and he was instructed to pay all creditors who would accept as payment 33½ cents on the dollar. Their assets are estimated at \$21,000, while liabilities amount to over \$30,000. This company were burned out a short time ago for the third time in Dallas, but they again opened business with fatal results. The largest creditors are: M. Fitzgerald & Co., Providence, \$2,038; Spencer Optical Company, New York, \$1,514; Thomas Ingraham & Co., Bristol, Conn., \$1,865; Manhattan Silver Plate Company, Lyons, N. Y., \$2,375.

Philadelphia.

Charles H. O'Bryon, of the firm of Louis A. Scherr & Co., who was confined to his home by illness for some time, is again able to attend to his business duties.

R. G. Porter, of Woodbury, N. J., spent several days in the city during the past week purchasing goods.

Among the out-of-town representatives who were in the city last week were Eugene McDonald, representing Snail & Co., of New York, who is on his way West; and William Wightman, representing R. F. Simmons & Co., of Attleboro Falls, Mass., who is East-bound.

Sumner Blockington, of W. & S. Blockington, will be in the city during the coming week.

The partnership heretofore existing between William E. McCall and John S. Newman, 625 Arch street, has been dissolved by mutual consent. William E. McCall will continue the business.

James Lucey, the boy who was charged with stealing a watch belonging to Muhr, of Chester, was discharged by Magistrate Clement on the 2d inst. It was shown that the young fellow speculated in watches. The one in question he bought from a pawnbroker for fifty cents and pledged it again for seventy-five cents.

As there seems to be considerable dissatisfaction among jewelers and others not in the trade concerning watch clubs, another scheme has been started here for the sale of jewelry of all sorts on the installment plan. While this is somewhat of the nature of watch clubs, it is claimed that in no case will the cost of articles received be equal to their price. This seems somewhat strange, but it is explained in this way: Clubs are formed, with 50 members in each, who pay \$1 weekly. Should any member fail to pay on the day that his money is due, he lapses, and on failure to pay on the second week, he is dropped, the association by written agreement retaining the money previously paid in. When these men lapse the others are advanced, and when they reach the head, they cease payment and get their jewelry of the supposed value, of \$35. This looks very inviting. The association has not yet begun operations, but its founder, W. L. Headly, a Filbert street jeweler, thinks that it will be successful.

There is scarcely any likelihood that it will materially effect the regular jewelry trade.

Norfolk.

A new store but recently opened here is that of Mrs. F. Spertner, known as the "Jewelry Palace." This store ranks among the finest here. It has done much good to promote the jewelry trade to Church street.

The following gentlemen were in town recently: I. N. See, representing David F. Conover, of Philadelphia, Pa.; Mr. Siechel, representing Samuel Eichburg, of Maiden Lane, New York; Kosuth Marx, of The Kosuth Marx Co., New York, and Mr. Lip-pers, of Isidore Elbe & Co., New York City.

St. Louis.

Henry Mauch came to St. Louis from Stuttgart, Germany, about forty years ago, and with his brother, also a watchmaker, began business here. Henry died in 1887 and his brother has since retired from business and is now in Europe enjoying himself. Four of Henry Mauch's sons are engaged in watchmaking on their own account, and one other son is learning the trade with the assistance of one of his brothers. Charles A. is at Marshall, Missouri; Albert, is at 3201 South Seventh street; William at 1436 South Broadway; Herman at 407 Franklin avenue; and Otto, the youngest brother, is in Herman's employ. All are prosperous, well-to-do workmen.

The following traveling salesmen registered at the Mermod Jaccard Jewelry Co. this week: A. R. Dorchester, of Brown & Dorchester; W. P. Mulcher, of Shoemaker, Picking & Co.; C. W. Cary, of J. B. & S. M Knowles, A. B. Snow, of G. & S. Owens & Co.; T. H. Pope, of Acme Silver Plate Co.; George Sexton, of Seth Thomas Clock Co., and J. D. Underwood, of Champenois & Co.

Gill & Morrison, of 616 Olive street, have found their present quarters too cramped and have made an offer for the rental of the adjoining premises which if it is accepted will give them ten feet more of floor space.

Eugene Quendet, president of the E. Jaccard Jewelry Co., is still troubled the with parlytic affliction which came upon him two years ago. He is still attending to business, however, and making a good fight against the disease.

Cincinnati.

The recent meeting of the National Association in New York has been very generally discussed during the past week by the members in this city. The action of Oskamp, Nolting & Co. in paying up their fine and of again seeking admission to the Association has had an encouraging effect in that it has made the Association stronger in this city.

The final action of the convention meets with hearty endorsement of the members in this city. They are greatly in favor of rigidly enforcing the rules of the Association, believing as they do that only through the enforcement of the rules and the imposition of penalties can the watch trade retain the high position it now holds in the commercial world.

While several firms who were members of the local association have been recently suspended for the non-payment of fines, the general opinion seems to be that in time they will find that the utter uselessness of trying to carry on a watch-jobbing trade without being members of the Association, and that they will follow the example of Oskamp, Nolting & Co. and return to the fold.

The latest suspension from the Association is the firm of Amberg & Co., who failed to pay the fine assessed against them about two weeks ago. It is believed that they will soon settle and be restored to their membership.

How to Analyze Native Alloys Containing Gold, Silver, Platinum, etc.

MANY of the readers of the JEWELERS' CIRCULAR live in regions in which auriferous native alloys are found, combined by nature in the bosom of the earth, and, as is very likely to be the case, in absence of an analyzing chemist, one or the other may be called upon to determine the different metallic substances of which a given sample is composed. It would never do for him or them to plead ignorance of the simple method for doing this, and it is therefore well to either copy this article and lay the transcript aside for further reference, or else make a memorandum of this volume, number and page of the JEWELERS' CIRCULAR, in order to know where to find the information when it is wanted.

These affinities are well known in chemistry, and the analysis of a metallic compound, consisting of a variety of different metals, is an easy matter. Let us suppose that a metallic mass is made up of platinum, gold, silver, bismuth, lead, iron and copper; we then separate the constituent parts in the following manner:

1. The alloy must be comminuted by either filling or granulation; it is next digested in diluted nitric acid, until this agent exerts no further action on the residue. In order to be certain that the digestion of the soluble parts is completed, decant the acid from the residue, and pour small quantities of fresh acid, until all action ceases. Add the last acid to the former decantations; the residue, consisting of gold and platinum, must be washed with a small quantity of lukewarm water, which is also added to the decanted acids.

2. Pour quantities of cold water into the solution, until all turbidity ceases, then permit the precipitate to settle, after which dry it. This is the oxide of bismuth, of which 123 parts, dry, equal 100 parts metallic bismuth; the analyzer may, if he chooses, reduce it to its metallic state by mixing the dry precipitate with oil to the consistency of a thick paste, and fusing it briskly under a cover of charcoal dust.

3. Concentrate the fluid from which the bismuth was separated, by boiling it to about half its volume, and immerse into it a clean copper plate; the silver will then settle on the copper in a metallic state; collect the former from the latter by washing, and re-

peat the process of immersion, etc., until no more precipitate is formed. The silver may then be dried and reduced to a button by melting it with a little carbonate of soda.

4. Next separate the lead by dropping sulphuric acid into the fluid of the last process until precipitation takes place no longer. The precipitate obtained is sulphate of lead, of which 100 parts, when perfectly dry, equal 30 parts metallic lead.

5. The fluid is then mixed with liquid ammonia, by which a brown precipitate is thrown down; this is iron which was contained in the alloy.

6. We have now obtained four metals; bismuth, silver, lead and iron, from the same fluid. It should next be tested for copper. Pour into it a saturated solution of potash, and boil the fluid a little; the ammonia is volatilized thereby, and an oxide of copper is precipitated. To obtain the copper in a metallic state, dissolve this oxide in muriatic acid, and dilute with an equal quantity of water; then immerse into a clean iron plate, when the copper will adhere to it.

7. Next take the insoluble residue left in the first process, and dissolve it in aqua regia, a mixture of three parts of muriatic and one of nitric acid, till a complete solution is effected. Mingle this solution with a saturated solution of sal ammonia, and the platinum will become separated as a precipitate and leave the gold in the solution. The precipitated platinum is well washed and boiled in clear water to soak out the ammonia, and finally washed with alcohol, it is then ready to be welded to the metallic state.

8. To recover the gold, mingle the remaining solution from which the platinum has been separated with a diluted solution of sulphate of iron, a precipitate falls down, which is metallic gold; collect and fuse it with a little borax into a solid mass.

The analysis is now completed, and the combined weight of the obtained products will correspond with the weight of the substance submitted to examination, if the manipulation has been done carefully.

The Lustre of Metals.

DOVE was the first to attempt an investigation of the causes of metallic lustre. He had examined by the aid of a stereoscope, two images of a pyramid, one being colored

blue and the other yellow, expecting to find a relief image of a green color. He was astonished, however, to discover that the mixture of colors gave a reflection like that of a polished metallic surface. Having repeated the experiment, using a black and a white image, he obtained the metallic grey of lead and tin. Dove concluded that metallic lustre is due to two reflections from superposed surfaces, and that the accommodation of the eye being different for each color, a perfect coincidence of the images of different colors was impossible. The lustre of metals would thus be caused by a reflection from the actual surface, and another from beneath the surface. This explanation attributes a considerable degree of transparency to the metals, more indeed than seems consistent with parts.

Brücke offered another theory, according to which the color of light reflected from bodies not possessing the metallic lustre, should be independent of the local color—that is, the color of the reflecting body—while in the case of metals the color of the reflected light is that attributed to the substance, the incidental light being white. He also considered that a certain intensity of reflection was a necessary condition for metallic lustre, this intensity resulting from the capacity of the metals, and he mentions the phenomenon of total reflection as producing a perfect imitation of metallic lustre.

These theories of Dove and Brücke represent opposing views of the transparency of the metal; the one considers them as opaque, the other as transparent. Herr W. Spring (Bull. Soc. chem., 50, 219) endeavors to reconcile these views by a study of the nature of the surfaces of the solids he has obtained during his experiments on the compression of solids within polished steel cylinders. He finds that substances which in the form of powder are opaque produce solids that have a metallic lustre, whatever the nature of the substance, while such substances as yield powders more or less transparent formed cylinders having vitreous surfaces, looking as if varnished.

Ramsgate & Blog in Trouble.

Deputy Sheriff Carraher took possession last Friday of the diamond-cutting place of Ramsgate & Blog, at No. 10 Maiden Lane, on executions for \$6,198, of which \$4,270 was in favor of Henrietta Hemmendinger, and and \$1,928 in favor of Marguerite Blog.



W. ROSENTALL,

Manufacturer of

SILK VEST CHAINS,

79 NASSAU STREET, NEW YORK.

Send for Selection Package.

G. F. FEINIER,

MANUFACTURER OF

WATCH CASES,

Repairing of Every Description,

NO. 9 BOND STREET, NEW YORK.

Key-Wind Cases Altered to Stem-Wind, and made same as New. English Cases Altered to take American Movements.

FILIGREE JEWELRY.

IS MADE OF GOLD OR SILVER IN

Lace Pins, Hair, Hat, Scarf and Jersey Pins, Bracelets, &c.

Also in Wedding Jewelry, Bridal Diadems, Myrtle Wreaths, etc., by

P. HARTMANN,

36 Maiden Lane,

NEW YORK.

— FOR THE —

Best of INKSTANDS for Use or Selling,
APPLY FOR TERMS TO ABOVE.



The Other Side of Life.**ALL PARTED.**

Alas they parted, he and she,
Although for years their love was one,
Sorrowfully and tearfully,
They parted at the set of sun.

The gem which gleamed on her fair hand,
A token of unbroken troth,
Left its sweet bed at her command
To prove, she saith, his nature's froth.

For months the gem lay hid from light,
Until he raised it from his pocket,
And gazing on the novel sight,
He saith within, "I guess I'll hock it."

A ton of diamonds at the present day is worth \$35,000,000. We furnish this information to prevent the public being over charged.

It is not always good policy to lock the safe after the diamonds have been stolen. The thief might repent and bring the diamonds back.

Timpany (jeweler)—I have never known business to be so dull.

"You should advertise,"

"In which way?"

"Have your diamonds stolen."

FLEDGELY—I love you, Alice! will you be mine!

ALICE—What are your ideas regarding rings?

FLEDGELY—Diamonds.

ALICE—Take me.

THE DIFFERENCE.

"Here, sir, is a fine silver watch for \$15. Here is another equally as good for \$10."

"What's the difference between them?"

"Five dollars."

ONLY PASTIME.

Cholly Cholmondeley (meeting Harold Harrington coming out of Jimpson's)—How do, old fel; what have you been doing in there?

Harold Harrington—Oh, only passing away my time.

A STEADY JOB.

"And pwhat bes yer hoosband doin' now, Mrs. O'Flaherty?"

"Faith, he bes doin' tin days."

A TRUTHFUL BURGLAR.

"Who is that below?" called out the lady of the house.

"Billy, the slug, at your service, ma'am," answered the burglar who was making off with her silver.

ETERNAL FITNESS OF THINGS.

MRS. SHYSTER DE PUYSER.—What a lovely pearl belt Mrs. Croesus Bullion is wearing.

MRS. T. MONTMORENCY BOBS-JONES.—Very lovely, Mr. Bullion bought it as a necklace but it was too small.

SUFFICIENT CAUSE.

PONSBY—You are looking exceedingly unwell, Popinjay, dyspepsia?

POPINJAY—No, I have not recovered from the nervous shock I received when my wife presented me last Christmas with a watch accompanied by a receipted bill.

HIS BILL WAS NOT DUE.

JEWELER—You said, Knowles, when I sold you that watch, that you would pay me in two weeks. It is now over a month since I sold it to you.

KNOWLES—Not by the watch; it loses a half day each day.

Wanted Money, Not Cigars.

WINDSOR LOCKS, Conn., Feb. 3.—In October J. W. Browning's jewelry and drug store was entered by burglars. Mr. Browning, it is claimed, went to Constable Kinney and offered him \$50 for the arrest and conviction of the burglars. Kinney arrested three men, who proved to be the right parties. One was bound over and later sent to prison for two years, and the other two were discharged for lack of evidence. Mr. Kinney also did two other jobs of work for Mr. Browning. For these and the reward offered by him, he has presented a bill for \$75. When Kinney first asked for his money Mr. Browning looked

amazed, and said he did not remember that he ever offered any reward, and asked Kinney if he had not always treated him well, or offered him a cigar when he entered his store. Mr. Kinney told him he could pay the amount asked or he would sue him, and the amount not having been paid he has placed an attachment on Browning's store for \$100. Mr. Browning is a popular citizen, well to do, and could pay the bill a thousand times over if he chose, but his claim is that he does not owe the bill, nor has he offered any reward.

Snatched a Watch.

KANSAS CITY, Mo., Feb. 1.—At 3:15 o'clock yesterday afternoon a railroad man thirty or thirty-five years old, about five feet seven inches high and of 175 pounds weight, stepped into Hart & Currier's store on Main street and asked to look at some watches. While thus engaged he suddenly snatched a gold-filled watch with Elgin or Waltham movement and escaped with it. The watch has an engraved screw bevel case. The thief looked as though he had been drinking, and had a scar over his left eye.

A Jeweler Fails.

GALVESTON, Tex., Jan. 20.—D. Shaw, jeweler, on Market street, has failed and his store and stock is in the hands of Felix Simonds, who has been made trustee. An inventory of stock is being taken. The liabilities, as taken from the county records, are as follows: Adone & Lobit, \$1,000; M. C. Shaw, \$3,363.21; C. G. Alford, New York, \$550.47; Koch & Dreyfus, New York, \$530; M. B. Bryant, New York, 442.51; total, \$5,886.19. The assets have not been stated.

Deed of Trust Filed.

TAYLOR, Texas, Jan. 31.—The deeds were filed to-day to transfer the stock of drugs and jewelry, also real estate, of Dr. F. L. Cook, of Taylor, to his father, E. B. Cook, of Cornell county. Consideration, \$16,000.

— THE —

COURVOISIER, WILCOX MFG. COMPANY



WILL PUT on the market about the middle of February, a New 10-K. Gold Watch Case in 0 and 6 size, which for beauty of design, finish and style, will be unsurpassed.



It will be stamped

WARRANTED

STANDARD

U. S. ASSAY.

C. W. MFG. CO.



Boston.

Max Newman, jeweler, 15 Avon Place, has failed. His liabilities are stated to be about \$23,000.

Mr. H. W. Patterson, of Smith & Patterson, is in Montreal, where the firm has a branch office.

Mr. H. A. Flinn, formerly with Foster & Emerson, will continue at the old stand with the new firm of E. F. Wilson & Co. as head salesman.

Col. Stevens, the new representative East for the Brooklyn Watch Case Company, dropped in to shake hands with the Boston boys last week.

Amethysts are ingratiating themselves into popular favor more and more. "With them, as with opals," remarks a prominent jeweler lately to the writer. "a strong tide of fashion has set in, and they are likely to be on the top wave this year."

John F. Naulty & Co., jewelers, 859 Washington street, have assigned to P. O'Laughlin, attorney, of this city. The liabilities are about \$5,500, and the assets consist mainly of the stock.

Mr. E. E. Hardy, representing D. C. Percival & Co., is making calls in the Granite State this week, and Mr. E. W. Merrill, of the same house, is similarly occupied in Western Massachusetts.

Mr. W. O. Thiery, New England, traveling man for the Illinois Watch Company, who has just closed his first year with that concern, starts off again in good order and "warranted for another year," this week.

Mr. W. H. Prescott, formerly traveling salesman for the Brooklyn Watch Case Company, has returned to his old-time employers, Smith & Patterson. He will be one of their inside salesmen for the current year.

Twenty-five years of prison life stare William J. Crotty in the face. Crotty is the darling thief who robbed Mr. William B. Morse, 268 Tremont street, this city, of a tray of diamond rings and scarf-pins, valued at \$1,000 during Christmas.

Two Winnipegers have escaped for a brief season from the severities of Manitoba winter weather. One of them is the representative of W. H. Pollock & Co., of that city, and the other is President W. F. Doll, of the Winnipeg Jewelry Company, both of whom visited their Boston brethren last week.

President Daniel Stevens, of the recently organized Jewelry Travelers' Association of New England, is with D. L. Percival & Co.; vice-president John L. Shepherd represents the Keystone Watch Case Company; Secretary H. F. Hayes, Floyd, Pratt & Co.; Treasurer William S. Robinson, the Ripley-Howland Company.

Among the travelers in town last week were: Mr. Rowe, of the Ingraham Clock Company, Bristol; Mr. Harry Beace, of the Wilcox Silver Plate Company, Meriden, Conn.; Mr. McDonough, of Courveseir, Wilcox & Co., New York; Mr. E. T. Tiffany, of Sadler & Co.; Mr. Marshall, of Williams &

Co., Providence; Mr. Granbery, of New York; Mr. W. H. Jones, of Larter, Elcox & Co.; Mr. F. I. Marcy, of Providence.

Messrs. Foster & Emerson, now at 409 Washington street, will remove this week to the stand occupied by Wilson Bros., 6 Hanover street, prior to their removal to Tremont row. Mr. E. Frank Wilson, for the past eight years with Morrill Bros., is to have the quarters at 409 Washington street, vacated by Foster & Emerson. He starts in business with the best wishes of a host of friends in the trade, for he has been the right-hand man of his late employers and made many acquaintances who wish him success.

Involuntary insolvency proceedings have been instituted in the Norfolk County Court at Dedham, Mass., against Charles T. Seaverns and Henry G. Seaverns, of Brookline, that county, and John Vose, of Boston, the diamond merchants, whose failure under the firm name of Charles T. Seaverns & Co., was made public just before Christmas. Their place of business was in this city and their assets nominally equalled their liabilities, which amounted, it was said, to about \$80,000. The firm of Sanford & Cook, New York, is the petitioner, and the case comes up today (Feb. 4). In the Norfolk registry an attachment of \$15,000 has been made by Emil A. Neresheimer *et al.* upon the estates of Charles F. and Henry G. Seaverns and trustee.

The creditors of Frank H. Frueh, jeweler and watchmaker at 491 Washington street, after listening to the report of their committee of investigation, submitted at a meeting held January 12, decided upon a settlement through the insolvency court. Mr. J. H. Appleton, representing the committee, stated that the liabilities amounted to \$14,326.94 and the assets nominally to \$11,033.30—\$799 in fixtures and \$10,234.30 in stock. He informed the meeting, however, that these valuations, which were the debtor's estimates, were so high in comparison with what stock and fixtures would bring in the market that 30 per cent. would be as much as they could expect to realize. Mr. Frueh then made an offer of 25 cents on the dollar, but the meeting would not accept it. The stock was sold January 27, for \$3500 to T. H. Davis.

New Haven.

The property of the Cheshire Clock Co. will be sold at auction next Tuesday.

Edmund A. Park, of Wallingford, was among the guests at the annual banquet of the Chicago Jewelers' Association.

F. Lyman, of Bridgeport, is meeting with continued prosperity and has improved his store and ordered a new 3-ton safe.

A. D. White, of this city, continues dangerously ill. As he is somewhat advanced in life fears are entertained that he may not recover.

C. G. Earle has his store front well covered with advertising lettering, booming his closing-out sale. He has been doing an ex-

cellent business, but thought the increase of rent asked for the store, too high. He talks of locating in Bridgeport.

The salesmen of E. A. Bliss & Co., Meriden, manufacturers of silver and nickel-plated novelties, started out on their spring campaign last week.

President Hiram Camp, of the New Haven Clock Co., who not long ago built a \$10,000 church next to his handsome residence and donated it to the society, has now been honored by having a new division of the Sons of Temperance named after him. Mr. Camp is a staunch prohibitionist and has run for governor of Connecticut not long ago on the Prohibition State ticket.

The Meriden Britannia Co. directors elected last week are: W. W. Lyman, of Meriden; C. Bery Peets, New Haven, George Rockwell, D. B. Hamilton, of Waterbury, and F. P. Wilcox, of New York. Messrs. Peets and F. P. Wilcox were elected to fill the vacancies caused by the deaths of ex-Congressman Mitchell, of New Haven, and Horace C. Wilcox, Meriden. The directors re-elected the old board of officers, viz.: President I. C. Lewis, secretary, G. H. Wilcox, treasurer, G. R. Curtis, assistant treasurer, G. M. Curtis.

Kansas City.

U. G. Cuthbert, of this city, went on the road for Otto, Young & Co., of Chicago, January 1st. He spent last Sunday, here.

W. S. Dudley was in this city Friday booking orders for Rogers, Smith & Co., of Meriden, Conn. He had a nice trade here and left for St. Louis.

T. S. Carrow, Shafer & Douglas, Luther Hyde, Reed & Burton, E. F. Hopkins, Meriden Silver Plate Company, Paul Bohme, Wilcox Silver Plate Company, David Beer and Leopold, Weil & Co., were in the city last week.

Samuel Streicher has moved from 915 to 1017 Main street. The new store has nearly twice as much floor space as the old one, and is in a better locality. The building is also lighted by electricity. Mr. Streicher is making a specialty of watches. He left on Sunday for a flying trip to Chicago and New York.

The retail merchants of the city have just perfected an organization to protect themselves from firms doing a general business, whose methods of making a "run" on one or more lines each week has demoralized trade. The jewelry trade is represented on committees by M. B. Wright, F. W. Meyer, and C. I. Lee.

Frank Winter, for some time diamond setter for the Jaccard Watch & Jewelry Company, was arrested for stealing a stone which he was given to mount. He was entrapped by use of a prepared package of diamonds. When accused he confessed that he had been stealing for some time. A \$150 diamond was found in the shop where he had hidden it. He was told to leave town and it is supposed that he has gone to St. Louis. Louis Guendler, of St. Louis, has been engaged to fill his place.

Queries and Answers.

Inquiries addressed to THE CIRCULAR will receive a reply either through the columns of the paper or by mail. Answers will be given as promptly as practicable.

To Make Brass Castings.

MEDINA, O., Jan. 10, 1891.

To the Editor of The Circular.

Will you please give me some instructions in casting small articles in brass, such as blanks for the wheels and other parts of clocks? I have a brass "flask" such as is used in iron foundries and know how to mold from patterns; but I do not get very smooth surfaces nor such sharp corners as I would like. Is there any particular kind of sand to use, or any particular way to use it? Also, what is the composition of the "hell metal" that polishing slips are made of?

H. A. U.

The sand used has a good deal to do with the perfectness of the castings. A sand which is obtained at Waterford, N. Y., is the best. Our correspondent could probably obtain this or some other equally good sand by applying to the nearest brass foundry. A sand is needed which has from one to two per cent of clay, and also has a proper size and shape of grains. The sand must be moistened a little but not too much to make it hold together well. A visit to an iron foundry will give a good idea on this as well as on many other practical points about molding.

When a very smooth casting is required a little molasses is put in the water with which the sand is moistened, for the purpose of having the sand stick together more smoothly. The mold is then thoroughly baked, to dry it and prevent the hot metal from being chilled when poured. This is called "dry sand casting" and is especially for objects in the more precious metals. For casting in brass so much trouble would seldom be taken, but ordinary sand would be used.

The surface of the pattern has much to do with the result. For fine castings, varnish the wood pattern with shellac dissolved in alcohol and when dry rub it smooth with fine sand paper. Do this three or four times. Or you can fill the grain of the wood and get a very smooth pattern by mixing a little whiting with the shellac and alcohol and rubbing well on the pattern. After being finished as before described, take a dry brush and rub well with black lead of the best quality; such as used by electrotypers. This gives a very smooth, slippery surface and promotes smooth molding. If you use sand cores they can be given a similarly smooth surface by a mixture of molasses and water thickened with black lead and put on the core with some smooth metal surface; such as a knife blade. Slick the core well and it will shine like glass and be nearly as smooth.

Of course it must be dried before using. Before putting on the upper half of the flask dust the surface of the sand in the flask with fine charcoal dust. This is made by crushing or grating some charcoal fine and tying it up in a bag of cloth, such as "cheese bandage cloth." This is to prevent the sand of the two halves from sticking together.

Melt your metal thoroughly in a crucible, keeping the surface well covered with fine charcoal dust. This is as necessary for low grade gold, or even twelve or fourteen karat gold, as for brass. But before pouring blow off the most of the charcoal dust with a pair of hand bellows, to avoid risk of some of it going into the mold with the melted metal.

If you want something extra perfect and are prepared to take the extra trouble, you can make a facing powder for the mold by carefully mixing 81 parts best molding sand, 15 parts fine pumice stone, 3 parts calcined magnesia and one part pulverized sugar of milk, and sifting this over the pattern with a sieve. The mixture must be perfectly dry and enough must be used to make a thin layer over the face of the pattern, after which the flask is filled by sifting on the usual damp molding-sand with careful tamping. The moisture of the sand diffuses through the layer of facing material and makes it hold together. This gives a very smooth surface.

Another process is by a modification of plaster of paris molds. Make a mixture of 1 part of plaster of paris and 2 parts of fine brick dust, mix with water to a rather thick paste, pour into a paper box until the box is about half full and immerse your pattern in the mixture, pressing it down until it is as deep in the mass as it will be when covered by the sand in the lower half of the flask. When the paste has set, dig notches in it around the edges, to act as ears or guides in place of the steady pins in a flask. Then thoroughly grease the upper surface of the plaster and fill the upper half of the mold with another mixture of plaster and water. When dry and hard remove the upper half, and then the pattern. The grease is to prevent the two halves of the plaster from sticking together. When the mold is perfectly hard and dry, heat it red hot in a furnace. When it is cooled it will be ready for use. With such a mold, patterns can be used which cannot be extracted, such as bugs, small animals, fruits, leaves, etc., and they are then burned out by heating the mold red hot. If necessary, patterns that are too complicated to remove can be burned out in this manner.

For making polishing slips, a bell metal alloy of 72 parts copper, 26.56 parts tin, and 1.44 parts iron is considered about the best.

Interesting Questions.

DANVERS, MASS., Jan. 14th, 1890.

To the Editor of The Jeweler's Circular:

I WOULD like to submit a few questions. Can you tell me where the moonstone comes from, and what is its mercantile value? 2. What are "rose diamonds" such as are mostly used in initial rings? 3. What is meant by the "going barrel" of a watch? 4. What is the best method for cleaning and restoring the brilliancy of gold plated watch chains that have become shop

worn? 5. In taking account of stock how is the value generally determined? By the wholesale price paid for it, or what it probably would be worth to-day? Say one had a lot of old fashion neck chains, earrings etc., that probably would not be worth 10 cents on the dollar. 6. How can I clean the old filings, mostly brass, copper, soft solder, etc., out of my files, so that they will cut better?

JEWELER.

1. The moonstone occurs in veins and cavities in granite, gneiss, clay-slate, limestone with quartz, amethyst, etc., at St. Gothard, Switzerland, where crystals, sometimes even a foot in thickness, have been found; in granite in North America; in New York in veins of quartz traversing limestone; in Great Britain in the granite of Araroa; and in veins passing through schistose on the northern coast of Cornwall. The finest specimens of moonstone occur imbedded in granite in Ceylon. Moonstones are worth from 25 cents a dozen to \$1.00 each in their state when imported. For recutting them, which is almost always done, a charge of from 25 to 50 cents is made.

2. The rose diamond is one that has a flat base, above which are two rows of triangular facets, the six uppermost meeting in a point. They are made of those stones which are too broad in proportion to their depth to be cut as brilliants.

3. The barrel of a watch or clock round which are teeth for driving the train direct without the intervention of a fusee. In other words the barrel of almost every modern watch which has no fusee.

4. Brush your chains with hot soap water to which a little ammonia has been added. Then rinse in alcohol and dry in warm sawdust. Tarnished gold may be renovated and the oxide removed from new or soiled works by applying warm spirits of wine with a soft brush or flannel, when its brilliancy will be restored again.

5. By its present commercial wholesale value.

6. When the surface of a file is choked with particles of iron, copper, wood, etc., while the cutting edges are still good, it can be cleaned as follows: Place the file for a few seconds in a hot lye of potash in water, withdraw; dry before the fire, and brush the surface with a stiff brush.

The Familiar Question.

HAYNEVILLE, LA., Jan. 12, 1891.

To the Editor of the Jeweler's Circular:

DOES the wholesale jeweler or jobber have a right to deal with common merchants? If not, is there any way, or do the laws of the association provide wherein they may be dealt with?

Have they any right to send to common merchants, dry goods houses, etc., their catalogues and private discounts.

W. M. WOOD.

The general sentiment of the jobbers of the country is against the wholesale jeweler and jobber dealing with common merchants. Still, it is a question that is at the present day receiving attention from jobbers. As yet no rule has been made—because it seems impossible that one could be enforced—that will prohibit the practice. This, of course, applies practically to thickly-settled districts. In sparsely settled localities, where there is but one general store that deals in all sorts

of goods, there can be no reasonable objection to a jeweler selling his goods to such a store.

Jewelers have no right—morally—to send a catalogue with private discounts to anybody for individual use. But as for sending such to one who is generally recognized as in the trade, the rule specified above holds good.

But after all has been said and done that can be said and done, the fact remains that if a dealer in any sort of goods wishes to add jewelry to his stock, he can do so if he has the money.

Magnetized Watches.

WATERBURY, CONN., Jan. 22nd, 1891.

To the Editor of the Jewelers' Circular:

WILL you inform me which is the best method of ascertaining when parts of a watch have become magnetized?

F. GOODRICH.

To ascertain if any part of a watch is magnetized, take a small piece of iron wire (jewelers' binding wire), attach it to a silk thread, and fasten the silk thread to a small brass rod or a peg-wood, and approach the part or parts suspected. If the iron is attracted or set in motion, magnetism is the cause, and the suspected piece is affected. Before making a test remove the watch movement from the case, if this contains case springs, and try these separately, as in most instances case springs are affected by magnetism, while parts of the movement are not. It is also advisable in testing a watch movement to take the movement apart and test the pieces separately. The parts most likely to be affected are the balance, the balance spring and the fork. In some instances, very rare however, every part of the movement is affected. To divest steel of magnetism, a strong horse-shoe magnet, or several of them, are attached to a lathe, pointing outward. When these are set in motion, the parts to be operated upon are brought close to the magnet, and are likewise rotated by means of a twisted cord or any other appliance and gradually withdrawn from the effects of the magnet. More than one application may sometimes be necessary to remove all traces of magnetism, but with some practice success is assured every time. The springs of a watch case had better be annealed, rehardened, and tempered, or, what is still better, be replaced by new ones.

To Set an English Watch in Beat.

DURLACH, Pa., Jan. 19, 1891.

To the Editor of The Jewelers' Circular.

I WOULD like to know how to set an old English watch in proper beat. Will you kindly inform me through your valuable columns? N. N. EBERLY.

The method of setting an old English watch, that is, a lever watch, in beat, does not differ materially from setting any lever watch in beat except as to the means employed in some instances. Whereas most lever watches are set in beat by shifting the hairspring collet on the balance, some of the old English watches sprung under the balance are put in beat by unpinning the spring at the stationary brass balance spring-stud. This unpinning and thereby lengthening or shortening the balance spring if within moderate limits may be indulged in if, as is usually the case, the regulator has a long range from "fast" to "slow" or vice versa; and it depends on the position of the regulator whether or not it will be necessary to move the hairspring collet to avoid having the regulator too close to "slow" or to "fast."

To set a lever watch in beat as a general thing is not and ought not to be done by simply having the lever in the centre between the banking pins, but depends entirely on the conditions of the impulse faces of the pallets and on the unlocking resistance of the same. The balance, or rather the jewel pin ought to occupy such a position in the slot of the fork, that the escape wheel by its action on the pallets impels the balance on both sides with equal facility. The point, which we aim to make clear is brought to notice more distinctly by calling attention to the fact, that the engaging pallet in its contact with the escape wheel gradually lifts and drives the balance with more difficulty, while the disengaging pallet performs the same functions gradually with more ease; the former acting progressively on a shorter lever and the latter acting progressively on a longer lever.

The effects of these conditions are modified by the unlocking resistances which, as a rule, act in the opposite direction. As these conditions are variable factors and different in almost any two individual escapements, the spring ought to be set on the balance in such a manner that it is driven to both sides with equal facility.

In this connection the fact might be mentioned, that the club-tooth escape-wheel has an advantage over the English or ratchet-tooth escape wheel, provided the former drives the pallets with the points of the teeth first, and finishes driving them by the incline of its club teeth towards the end, which obviates the lengthening or shortening of the arms of the pallet towards the end of the impulse of either.

The Pacific Coast.

H. H. Purdy has opened a jewelry store at Downieville, Cal.

R. H. Lawrence opened a new store at Quincy, Cal., last week.

L. M. Wagner & Co., of Los Angeles, are importing their own diamonds.

C. H. Bush of 318 North Main street, Los Angeles, is now a manufacturing jeweler.

Read McCraney, of Lakeport, Cal., has recently enlarged his business, and increased his stock.

S. Conradi, of 121 N. Spring street, Los Angeles, has added an eye-glass department to his jewelry business.

F. Wansky, the pioneer jeweler of Eureka, Cal., has recently completed one of the most attractive business houses in the West.

Reicheneker & Co., manufacturing jewelers, of Seattle, Wash., have the wholesale agency for Reed & Barton's silverware and Spencer's diamond spectacles.

C. H. Wright, of Eureka, Cal., has furnished that city with an immense clock which has been placed in the Post Office. It will be regulated by observations of the sun taken by Mr. Wright and corrected for standard time.

J. SCHAWEL & CO.,
GOLD AND SILVER
 Refiners, Assayers and Sweep Smelters.
Importers and Melters of Platinum.
GOLD AND SILVER BULLION BOUGHT AND SOLD.
29 JOHN STREET,
NEW YORK.
 ESTABLISHED 1865.



NEW DESIGNS
 Class-Rings
 and Pins



RaZZle "Medal very satisfactory."
PuZZle "Class Rings gave splendid satisfaction."
DaZZle "They are now beautifully made in sterling silver and gold."
 Rings made by Haskell, New York, surprising popularity of this ring is the phenomena of the day. Every body is buying them. This novelty has created quite a sensation—Jewelers Weekly.
 "Received in good order. Pin, which is VERY satisfactory. We wrote yesterday for sample Class Ring and hope to get that order also."
 "Many thanks for rushing work ordered."
HENRY C. HASKELL,
 MAKER OF FINE JEWELRY,
 11 JOHN STREET, NEW YORK.



COPYRIGHT PLATES
 Sent to Dealers
 upon request.

Recent Patents

DESIGN No. 20,193 to 20,196, inclusive. SPOON. JOHN H. JOHNSTON, New York, N. Y.—Applications filed December 29, 1890. Serial Nos. 376,130 to 376,133, inclusive. Term of patents, 7 years.

445,600. FOUNTAIN-PEN. NOYES F. PALMER, Brooklyn, N. Y.—Filed Sept. 11, 1890. Serial No. 364,629. (No model.)

Claims.—The combination of a fountain-pen with a pen-section having a bell-shaped mouth, and with a tubular pen-plug having a pair of feed tongues, a central feed orifice, and an additional communicating duct the pen-plug being held in the pen-section by frictional contact, substantially as specified.

445,607. CLOCK-STRIKING MECHANISM. ALMERON M. LANE, Meriden, Conn.—Filed July 14, 1890. Serial No. 358,680. (No model.)

Claim.—A clock-striking train having an idle-wheel interposed between the pinion of the fly or fan-shaft and the wheel which drives said pinion, substantially as described, and for the purpose specified.

445,659. FORGING-BLANK FOR HOLLOW-HANDLED CUTLERY. WILLIAM H. CHAPIN, Toledo, Ohio.—Filed Feb. 26, 1890. Serial No. 341,894. (No model.)

Claim.—A forging-blank for the manufacture of hollow-handled cutlery and analogous articles, consisting of a tubular piece of metal of which a handle is subsequently made, having one end integrally closed and made tapering from its closed end to its open end, and a solid piece of crude metal of which a blade is subsequently made, welded by one end to the open end of said tubular part, substantially as set forth.

445,814. SEAMLESS PLATED WARE. GEORGE U. MEYER, Providence, R. I.—Filed July 1, 1890. Serial No. 357,357. (No specimens.)

Claim.—The herein-described process of making ingots for seamless wire, the same consisting in bending and drawing around the prepared core a sheet of solder, inserting the solder-covered core into a prepared tube of plating metal, forcing the plating-tube into close contact with the solder-covered core by contracting the diameter of the tube, and then subjecting the so-formed ingot to heat to melt the solder to unite the tube to the core, as described.

Stole \$10,000 Worth of Jewelry.

CHICAGO, Feb. 3.—Three brothers named Engmark, the oldest not yet 23 years of age, have been arrested for robbing the wholesale jewelry houses. The two younger brothers, E. J. and E. C. Engmark, were employed in two different wholesale jewelry houses. When filling orders they would slip goods into their pockets. The plunder would be turned over to the elder brother, George, who disposed of it to tradesmen in the city. No one suspected the goods were stolen, as he sold them close to the regular figure.

The proprietors of the jewelry houses had for some time past noticed the mysterious disappearance of goods, and detectives were working on the case. Suspicion was finally directed toward one of the Engmark boys, who, when asked the time by his employer, pulled from his pocket a new watch, which he hurriedly slipped back. The gentleman said nothing but notified the detectives, who watched the brothers and arrested George as he was leaving the house yesterday to dispose of the accumulations of last week to dealers. The aggregate stealings are about \$10,000.

WE WISH TO ANNOUNCE

That our line of Watches and Jewelry is now complete. Our stock is entirely new, and comprises everything pertaining to the legitimate jewelry trade.

CAN WE SERVE YOU?

KATLINSKY & GATZERT,
WHOLESALE JEWELERS,
 96 STATE STREET, CHICAGO.



J. W. RICHARDSON & CO.

MANUFACTURERS OF

SOLID · GOLD · EMBLEMS,

Charms, Pins, Buttons and Badges,

194 Broadway, N. Y. City.

Our Illustrated Catalogue sent to JOBBERS on Application

R. & L. FRIEDLANDER,
 Wholesale Jewelers,

—AND—

JOBBERS IN AMERICAN WATCHES,

Tools, Materials and Optical Goods,

65 & 67 NASSAU STREET, N. Y.

Factory, 50 BOND STREET.

Send Business Card and we will mail you our Watch and Jewelry Catalogue, No. 12, and our Tool, Material and Optical Catalogue, No. 14.



Try our Monarch American Mainsprings, \$12.00 PER GROSS,
 \$1.00 PER DOZEN.

POSITIVELY NO GOODS SOLD AT RETAIL.

—Established 1872.—

PLAINVILLE STOCK CO.



THIS TRADE-MARK REGISTERED, AND STAMPED ON ALL OUR GOODS.

BROOCHES, SCARF PINS, DROPS, SETS.

FACTORY AT PLAINVILLE, MASS.

SAMPLES AT 176 BROADWAY, NEW YORK.

ESTABLISHED 50 YEARS.

RANDEL, BAREMORE & BILLINGS,

IMPORTERS OF

DIAMONDS,

AND OTHER PRECIOUS STONES.

FINE PEARLS A SPECIALTY.

MANUFACTURERS OF

DIAMOND JEWELRY,

IN THE LATEST DESIGNS.

Diamonds Recut in Modern Styles or Repaired on Premises.

58 Nassau Street,
29 Maiden Lane,
NEW YORK.1 Tulp Straat,
AMSTERDAM.1 St. Andrews St.,
Holborn Circus,
LONDON, E. C.

THE FIRST AND SECOND EDITIONS OF

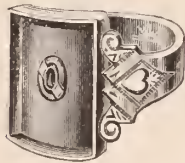
The  Sun.

Interchangeable Initial Ring

HAVE NOW BEEN ISSUED.

Send in Your Subscriptions at once.

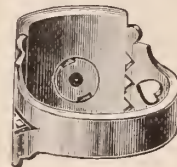

Simple in Construction; Easily Adjustable; ♦ ♦ ♦ ♦
 ♦ ♦ ♦ ♦ ♦ ♦ ♦ ♦ ♦ ♦ ♦
Satisfactory in Results.

Special Designs will be furnished to Jobbers for their exclusive use.

JULIUS WODISKA & CO.

49 Maiden Lane, New York. ✨ ✨

✨ Chicago Office: H. L. Joseph, 155 State St.

✂ TO THE JOBBING TRADE ONLY.

Industrial Schools.

MR. C. DIETZSCHOLD, well known to the reader as an occasional contributor to these columns, has laid THE CIRCULAR under obligations for a copy of his "Annual Report of the Empress Royal School of Horology" at Karlstein, Nether-Austria, for 1889-90. The pamphlet of twenty pages gives a succinct account of the transactions of the school during the scholastic year, and speaks in satisfactory terms of the results achieved. Sixty-one scholars were entered at the beginning of the year, of which number thirteen left during the course, forty-eight remaining until the close. They came from all parts of the empire—Nether-Austria, Bohemia, Tyrol, Hungary, Croatia, etc., and their ages averaged 16½ years. As might be expected the principal part of the course of study is devoted to the art of horology.

Geometrical drawing, technical drawing, mechanics and physics in the first year; rudimentary knowledge of timepieces in the second while the third year finally prepares the pupil for the watchmaker's bench. THE CIRCULAR congratulates its contributor upon his success, and hopes to be able to renew these congratulations for many years to come.

San Francisco.

The first week in January was quite dull. There appears to be a lull in both the wholesale and retail trade, as well as with the manufacturers. This lull is only temporary, however, and by the time February is well advanced there will be a general revival.

A story has just reached me of an unique advertising scheme recently practiced by a well known jeweler in Los Angeles. He engaged a bevy of very pretty girls and had them driven through the principal streets in an open wagon. Above them was a huge banner, bearing the words: "The men we marry must buy their jewelry of Parmalee."

Economy seems to be the rule on every hand. The largest houses in the city have been curtailing expenses. George C. Shreve & Co., who occupied four large store-rooms in the Occidental Hotel building on Montgomery street, have given up two of these rooms and will, until the removal to the new Crocker building, do business in the remaining two.

Hammersmith & Field, manufacturing jewelers, 118 Sutter street, this city, announce their latest novelty as a blotter, costing \$250. It is a silver plate in the shape of a slipper sole, with a blotter fastened beneath by pretty colored ribbons. On the face of the plate is engraved: "I wish you many returns of the day from the bottom of my soul." It has been exploited but a few days.

Lost Diamonds Found.

LOS ANGELES, Jan. 31.—Recently L. M. Wagner & Co., lost \$12,000 worth of diamonds and other jewels. To-day detectives learned that a Chinaman found a sack of jewels in St. James Park. The Chinaman has been traced of the jewels will be recovered.

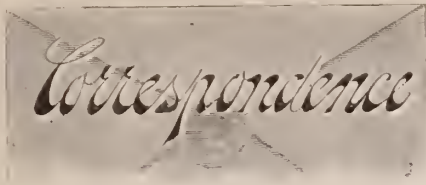

To Tax Jewelry Peddlers.

CAZENOVIA, N. Y., Jan. 22, 1891.

To the Editor of *The Jewelers' Circular*:

ALLOW me to suggest to the Jewelers' League, or to any other body representing the trade, the advisability of using its influence at Albany this winter to secure the passage of a law taxing peddlers in the cities, towns and villages where they ply their trade. They enjoy the benefits afforded by our laws and frequently call upon the authorities to help them to get pay for goods sold, or for protection from thieves. Why should they not pay for these privileges?

A regular dealer settled in a city or village is taxed, not only to help support the government which gives him protection, but he must also help pay for municipal improvements and maintenance of schools, besides being expected to respond to all calls upon him for money for church purposes or other benevolent objects.

These peddlers come among us and by persistent, personal entreaty, pursuing their victims even into their homes, badger them into buying goods from them, many times getting much more than their value, and often misrepresenting the goods sold. They pay no rent, no taxes, nothing for schools, nothing to keep up the roads over which they travel. Surely we retail dealers ought not to bear the burdens of these things alone, and we ask nothing more than that these irresponsible transients be placed on the same plane with us of responsibility in supporting the government.

Let an effort be made at this session of the Legislature to pass an act enabling cities, towns and villages to require all peddlers of manufactured articles to take out licenses in the places where they desire to do business.

J. W. HALL.

Scott Arrested.

George D. Scott, the manager of the Office Men's Watch & Jewelry Co., of St. Louis, Mo., is under arrest, charged with violating the State Lottery Law.

DIAMONDS.

Wm. S. Hedges & Co.,
Importers of Diamonds,

And Manufacturers of DIAMOND JEWELRY.
No. 170 BROADWAY,
S. E. Cor. Maiden Lane, } New York.

27 Holborn Viaduct, London.

TRADE MARK **J.G.C. & CO.** MARK

Manufacturers of
FINE
Rolled Plate
CHAINS.

J.G. Cheever & Co.

North Attleboro, Mass.

JOSEPH JONAS.

JACOB DORST.

JONAS, DORST & CO.,

Manufacturing Jewelers and Importers of Diamonds,
169, 171 RACE STREET,
CINCINNATI, OHIO.

WE MAKE A SPECIALTY OF ALL STYLES OF

✧ **DIAMOND MOUNTINGS.** ✧

Society and School Badges,

FANCY MONOGRAMS and RINGS of all Descriptions.

We are prepared and have complete facilities for doing REPAIR WORK with neatness and dispatch.

DESIGNS EXECUTED FOR SPECIAL WORK.

We are the exclusive manufacturers of the celebrated **Ophir Diamond** Goods.



◆ **DIAMONDS** ◆

Our Diamond Stock in the future will be separated into twelve grades, as follows:

- A. Blue-White and Perfect.
- B. " " " Imperfect.
- C. Extra White and Perfect.
- D. " " " Imperfect.
- 1. White and Perfect.
- 2. " " Slightly Imperfect.
- 3. " " Imperfect.
- 4. Very Good Color and Perfect.
- 5. " " " Slightly Imperfect.
- 6. " " " Imperfect.
- 7. Good Color and Perfect.
- 8. " " " Imperfect.

Each piece in addition to the regular number will have one of these letters or numbers to indicate the quality of the diamond. This will give you the benefit of our judgment as to the grade and quality of each stone, and, we believe, will help you in the purchase and sale of diamonds from our stock.

Copyrighted August 15, 1890.

Copyrighted August 15, 1890.

When in need of anything special in diamonds, send to us for an assortment on selection. Don't hesitate because you may never have had any previous dealings with us, as we should be glad to have you for a customer—and to have you give this new grading system of ours a trial.

J. T. SCOTT & CO.,

4 MAIDEN LANE,



NEW YORK.

Send for our New and very complete Illustrated Catalogue

OF THE
HOPKINS LATHES

AND ATTACHMENTS.

The best line of Attachments.

THE GREATEST ACCURACY IN ALL ITS PARTS.

Beauty in Design and Finish.



OUR 3 x 4 Lathe has the greatest chuck capacity, and in all the features that go to make up a perfect lathe, it stands at the head.

Don't throw your money away on cheap or imported lathes, when you can get first-class Standard American Goods, guaranteed by makers of long experience, at their present low figures.

Remember that a lathe which is not true is a poor tool at any price.

Address,

WALTHAM WATCH TOOL COMPANY,
SPRINGFIELD, MASS.

KINDLY MENTION THIS PAPER WHEN ORDERING.

Essex Watch Case

COMPANY,

T. B. HAGSTOZ, President.



6 Maiden Lane, N. Y.

OFFICE,

NEWARK, N. J.

FACTORY,

GOLD FILLED CASES.



The Latest "PURITAN" Design.

RICH CUT
GLASSWARE.



Headquarters in America for
ART GLASSWARES,
RICH CUT AND DECORATED.
Lamps, Vases and complete lines of everything for
table use or household decoration.

MT. WASHINGTON GLASS CO.

NEW BEDFORD, MASS.

NEW YORK OFFICE, 46 MURRAY STREET.

CATALOGUES FOR

INTENDING PURCHASERS.

North Attleboro.

Most of the shops are running on full time.

Charles W. Hemple, salesman for Young & Stern, left town on Feb. 1 for a Western trip.

E. B. Eaton, H. D. Merritt & Co.'s popular salesman, was in town this week. He will start West in about a fortnight.

W. A. Mason of this town has sold out his interest in the jewelry business which he conducted at Pawtucket, to Mrs. Helen C. Brown.

F. O. Coombs and family have returned to town. Mr. Coombs has just disposed of his interest in the firm of F. Mauser & Co., of New York.

Joseph Bagnall, foreman at Young & Stern's shop, who deserted his wife and children three weeks ago, has been heard of from Montreal, Can., where he was endeavoring to secure employment with Bolt & Co. His friends believe that he is not in his right mind.

Society here is a sort of "jewelry aristocracy," most of the upper-tendom of the town being composed of those who have made their money in its manufacture. For a wonder they manage to get along very smoothly; although there is a most intense jealousy in existence between the gentlemen in the daytime, when evening comes they disguise it with their "swallow-tails."

Attleboro creditors of Pond, Wilmes & Co., of Kansas City, are very much disgusted with the recent decision that there was nothing "crooked" about the failure. It would take more than the decision of a Missouri judge, to make them satisfied that they were not badly taken in. Clarence Pond, the senior member of the bankrupt firm, was for several years a resident of this town. He was considered a pleasant fellow and had many friends among the younger set of men.

A Room Full of Plunder.

LEADVILLE, Col., Feb. 5.—Adam Fischer, a shoemaker, was arrested last evening while leaving a building on Harrison avenue, which had been entered by a burglar a few hours before. The police were sent to his room, where they found goods of every description. There were gold watches, chains, diamonds, rings and other property, amounting in all to about \$7,000.

Fischer had \$700 in cash upon his person when arrested, while a certificate of deposit for \$700 on the American National Bank of this city was found in his room. A letter found in the room leads the officers to believe that Fischer had a confederate in San Francisco, to whom he had been shipping stolen goods.

CAZENOVIA, N. Y., Jan. 23, 1881

I am glad to see THE CIRCULAR taking such advanced ground on the elevation of the trade. The trade journals can do much toward restoring the old time prestige of the jewelry business.
J. W. HALL



WATCH . CASE . COMPANY.

SPECIALTIES:

Novelties

Raised Gold Ornamentation.	} <i>NEW STYLES</i>	
Inlaid Gold		"
Enamel		"

READY.

Staples

Extra Heavy Weight Cases,	} <i>ALWAYS IN</i>	
Howard Cases,		} <i>STOCK.</i>
18 Karat Cases.		

Our Product is one of the Largest. We are able to fill nearly all special orders at once.

OFFICES:

17 Maiden Lane, New York.

LOUIS DE GOLL,

220 Sutte Street, San Francisco.

General Agent

R. A. Kipling

Importer of Precious Stones

31, Union Square
New-York

19, Rue Drouot
Paris

The Highest Grade

— OF —

Electro Silver

Plated Ware

Is Stamped with the



ROGERS TRADE-MARKS.

MANUFACTURED BY

The Wm. Rogers Manufacturing Co.,

P. O. DRAWER 30,

HARTFORD, - CONN.

ALFRED H. SMITH & Co.,

DIAMONDS,

182 BROADWAY,

COR. JOHN STREET, NEW YORK.

33 HOLBORN VIADUCT,

LONDON, E. C.

FASHIONS in JEWELRY

Silver spurs are worn by New York equestrians of both sexes.

Fine lizard skin purses are provided with silver locks and corners.

Silver mounted rock crystal pitchers and claret jugs are in demand.

In some of the finger rings the gems are set entirely around the finger.

For chatelaines there are tiny pencils encircled with an enamelled snake.

The latest in prayer books and hymnals are those with gold mounted shell covers.

Claret jugs of fluted and engraved glass are enriched with silver handle and base.

Square watch seals and lockets are dividing favor with the round and oblong ones.

Numbered with the newer watch bracelets are those made of gold Milanese chain work.

Diamonds mounted on invisible pins of gold and worn in the hair are decidedly effective.

Fine amethysts are in demand and are especially effective when handsomely mounted for brooches.

Effective silver-mounted leather goods are made of ruby-hued morocco overlaid with silver filigree work.

A single flexible chain band of gold crossed by a diamond slide is a pleasing style of watch chain.

Five-stone hoop rings, in which diamonds alternate with sapphires and other precious stones are much worn.

An elegant trifle for smokers is an amber cigar holder with a finely enamelled band of silver around the centre.

The Maltese cross in enamel and dotted with diamonds makes an effective ornament mounted as a finger ring.

An appropriate present for a naturalist is an inkstand, the cover of which represents in beaten silver a life-size crab.

Pocket books, card cases, etc., in smooth, richly-colored lizard skin, show neat patterns in thin gold and silver mountings.

An attractive bracelet of two gold chains has for a fastening two little owls with pearl plumage, diamond heads and ruby eyes.

The jeweled dresses and jewel trimmings so much worn now, denote the fancy of the times for gems of all kinds and grades, color and shades.

Torquoises and diamonds are being extensively worn as Marquise medallion finger rings—the turquoise enhances the whiteness of the hand.

There are as many grades of corals as of cats eye. Some are quite worthless as jewels, while others are worthy of an encircling band of diamonds.

The newest ornaments for the table in biscuit boxes, cruets, fruit dishes and other single pieces, are a combination of crown Derby and silver.

Small elegancies in silver table gongs are modeled after a sign post. Another style simulates a mushroom under which a frog has taken shelter.

A novelty for the toilet table comes in form of hair brushes and hand glasses with ebony backs and handles, on which appear in silver wire the owner's monogram.

The new triple pencil has its silver case enamelled with black, red and blue bands to indicate the part of the pencil which must be turned to send out the corresponding color of lead.

Miniature paintings continue to find favor when set in brooches. A new style consists of an open-work border of gold apparently fastened together at one side by a little diamond ribbon bow.

To meet the requirements of the present fad for horseback riding, are a number of suggestive brooches, such as a gold whip thrust through a horse shoe, or a gold nail crossed by two horse shoes.

Mantel clocks of Royal Dresden with candelabra, are decorated in white and gold, as well as in colors. The silver slipper pin-cushion is greatly admired. Gentlemen's gold vest buttons come in sets of four; these may be plain, enamelled or chased, as suits the taste of the wearer.

Vase-shaped jugs of genuine Bohemian glass with silver necks and handles, are used as scent bottles on ladies' dressing tables.

A charming necklace for quite young ladies consists of a fine gold chain with a tourquoise or moonstone heart-shaped pendant.

ELSIE BEE.

A Thief Disguised as a Messenger.

Henry Purcell, nineteen years old, who has already served several terms on the Island, and who claims that he lives at No. 113 Manhattan avenue, Greenpoint, was arrested by Detective Sergeants O'Connor and Slausen, of the Central Office, on Feb. 1, with a lot of silverware in his possession, which it is charged he had stolen from Messrs. Reed, Barton & Co., No. 37 Union Square. It was also charged that he had robbed Messrs. Tiffany & Co. of \$20 worth of silverware, the Meriden Company, Wallack & Co., and the Gorham Manufacturing Company. The police say that Purcell goes into the stores as a messenger boy and walks around. Having the uniform on no one takes particular notice of him, believing that he is on an errand. A complaint of stealing \$40 worth of spoons from Reed, Barton & Co. was made against the prisoner, and he was held in the Jefferson Market Court, in \$1,000 for trial.

Montana Gem Beds Sold.

ST. PAUL, Minn., Feb. 1.—A St. Paul man has just received a cablegram from London which indicates that all the gem-bearing beds of Montana have been transferred to English capitalists. The property in question comprises several pieces of land, in all nearly 3,000 acres, the most interesting and important portions of which are Eldorado Bar and Ruby Placer. They both lie along the Missouri River to the north of Helena.

Charged With False Pretense.

ROCHESTER, N. Y., February 2.—P. W. Leonhardt, a Chicago man, was arrested here on a telegram from the Chicago authorities on the charge of obtaining goods under false pretense. It is said that he purchased a valuable diamond from a Chicago jewelry house and gave worthless checks in payment.



E. R. STOCKWELL,

19 JOHN ST., NEW YORK,
MANUFACTURER OF

Badges and Medals in Gold and Silver,

FOR ALL SOCIETIES,

INCLUDING

MASONIC,

ODD FELLOWS,

GRAND ARMY

ALSO FOR SCHOOLS.

✱ BUTTON BADGES IN SILVER OR GOLD. ✱

ENAMELING AND REPAIRING FOR THE TRADE.

N. J. FELIX,

(ESTABLISHED 1865.)

MANUFACTURER OF
GOLD and SILVER WATCH CASES,

ROOMS 6, 7 AND 8,
71 Nassau St., New York.



BEFORE—FRONT VIEW.

Old English Cases altered to Stem-Winding; also to Imitation Stem-Winding with key attachment to crown. Bezels altered to take flat glasses.

SEND FOR PRICE LIST.



AFTER.



BEFORE—BACK VIEW.

Orders or jobs sent me by mail or express always receive prompt and careful attention. As for references where he is not known, Mr. Felix can confidently state that he has done work continuously for the last twenty-five years for the very best houses in New York.

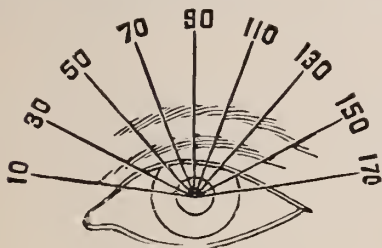

SEND TO

GENEVA OPTICAL CO.

23 Washington St., Chicago,

FOR

PRESCRIPTIONS, REPAIR AND ORDER WORK PROMPTLY at LOWEST PRICES

HILDRETH MFG. CO.,



PLAIN SOLID GOLD RINGS,



51-53 MAIDEN LANE, NEW YORK.

SEND FOR PRICE LIST.



Ruled, Printed and Indexed Records, ARRANGED TO SAVE TIME. Used by Advertisers, Book and Newspaper Publishers, Engineers and others to enter contracts quickly for instant reference.

HOWARD CHALLEN,
10 Spruce St., N. Y.



KENDRICK & DAVIS,
LEBANON, N. H.

MANUFACTURERS OF THE

Standard Dust Proof Watch Key.

After this date all Keys of this Style will have number stamped on each Key.

FOR SALE BY THE TRADE.

WELDED CHROME STEEL AND IRON

5 PLY.

FOR BUILDING

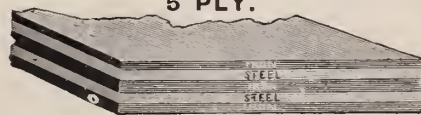

Jewelers' Safes, Vaults, Etc.

Positively Burglar Proof, cannot be Cut, Sawed or Drilled.

OUR TRADE MARK is stamped on all our goods and we caution purchasers to avoid imitations. We are the sole manufacturers of genuine Chrome Steel in the United States.

CHROME STEEL WORKS,

Kent Avenue, Keap and Hooper Sts., Brooklyn, N. Y.

S. H. KOHN, PRES. C. P. HAUGHIAN, VICE-PRES. J. G. DUNSCOMB, Sec.

CHROME



PLEASE READ THIS. *

*

*

IT IS JUST WHAT YOU ARE LOOKING FOR.

WILLIAM F. NYE:

DETROIT, MINNESOTA, Nov. 19TH, 1890.

DEAR SIR:—Some years ago I had a little experience with Watch Oils that I shall never forget. I had just located in this north-western country, and as you may know, the thermometer here in the winter goes down to 40° and 50°, and I have seen it down as low as 64° below zero. I had never paid any particular attention to Watch Oil, but used what my jobber sold me for the best. For some time I was greatly bothered with watches coming back to me apparently all right, but the customers said they would stop at night or at other times when subjected to extreme cold. After experimenting I found that the oil would congeal or become thick and stiff, and actually stop the watch. The question then arose, was there any oil that would stand this cold.

I ordered of my jobbers some six different brands of oil (your oil was one of them), and tested each oil by taking a movement in perfect condition, carefully cleaned and oiled with one brand, and placed it in a movement holder with glass back and front, and placed it out of doors when the thermometer was 50° below zero. After experimenting with one oil I would again carefully clean the movement and oil up with another brand of oil, and so on with all the different brands of oil I had, experimenting with the same movement in the same manner for each oil. The result was, with three of the oils the movement would stop inside of one minute. One would run one minute, and one nearly two minutes, and with only one oil would the movement continue to run without stopping. That one oil was yours, and it is needless to say that I have never attempted to use anything else since.

Respectfully yours,

D. L. BROWN.

The above is but one of the many letters we receive from customers in northern latitudes, where the thermometer sinks to hard-pan and announces Old Bo. eas holding high carnival in Arctic wastes. It was by reason of this pressing demand for an oil that would not congeal or become "thick and stiff" under his sway that led us to utilize his forces by establishing a plant in a Canadian climate for the preparation of the oil, and the result has proved most gratifying, "the one thing needful"—the "Ne Plus Ultra" of all oils heretofore offered for use on watches and clocks in either cold or hot countries, and we will only add that we have the assurance of the management of all the leading watch and clock factories, where most critical tests are made with the oil, that it affords them a satisfaction beyond any oil ever before offered in the adjustment and accurate rating of their present elaborate and costly timers.

ASK YOUR JOBBER FOR WILLIAM F. NYE'S OIL, AND TAKE NO OTHER IF YOU PREFER THE

Most Skillfully Refined Watch and Clock Oil in the World.

William F. Nye

NEW BEDFORD, MASS.

THE time-keeping qualities of Illinois Springfield Watches are unsurpassed; they are handsome in design and the very best finished movements on the market.

Our 18 and 16-size movements in open face have the best pendant setting device ever used.

A comparison of our line of 16-size movements with those of other manufacture, is all we ask; if they are not more accurately timed and adjusted, better finished, and handsomer in appearance, don't buy them.

We guarantee every movement of our manufacture and have no hesitancy in recommending them.

Our movements are sold direct to the retail trade and through our special jobbers.

Send for price-lists, illustrated catalogue and electrotypes.

ILLINOIS WATCH COMPANY,
SPRINGFIELD.

NEW YORK,
 11 John Street.

SAN FRANCISCO,
 220 Sutter Street.

CHICAGO,
 104 State Street.



PRETORIA, Transvaal, Jan. 14, 1891.

THE search for gold in the newly-explored region of Mashonaland is proceeding apace and it is expected that after the rainy season is over, about March, there will be a big rush in that direction. Johannesburg, the principal gold-mining centre in the Transvaal, is still in the doldrums, and its share market is practically dead. Good work is, nevertheless, taking place at the mines and the output for November was only a fraction under 50,000 ozs.

As furnishing some idea of the usual yield it may be stated that during the month of October forty-two companies produced gold. These concerns treated 69,643 tons of quartz with 1,095 stamps and obtained a total yield of 45,248 oze. 17 ducts of gold valued at £158,923, or 42s. 9d. per ton. The average yield was 12.21 ducts per ton, and the average quantity crushed per stamp per day equalled 2.40 tons. The largest output was made by the Robinson Company, which obtained 5,507 ounces, 7 ducts, or 30.49 ducts per ton crushed; the total value being £19,226 or 106s. 7d. per ton. This company employs 126 white men and 810 natives. The yield next in importance was the Langlaagte Estate, which yielded 4,550 ounces valued at £15,925, or 52s. 8d. per ton treated.

The diamond trade at Kimberly is at present suffering from a depression which is likely to last for a number of weeks longer, but which has not been altogether unexpected by those who are accustomed to watch the fluctuations of market, year in and year out. That market, as we all know on this side, is an extremely sensitive one, and is affected by financial and other conditions of influence to a much greater degree than are the productions and disposal of staple commodities which are absolute necessities in the economy of life. The cessation in the activity of large buyers, which was observable only a week or two ago, would have occurred in any case some time next month; but there are easily explainable reasons why there should be this early drop in prices, and the tale all round of "no business." The American purchasers, who constitute a most important factor in the regulation of the diamond market in Europe, appeared much earlier than usual on the scene this year. They bought all classes of goods more largely than is their wont, and this had a tendency to keep up the prices while the buying lasted. They have withdrawn from the market at a correspondingly earlier date, leaving a very appreciable void in the aggregate of cash employed in the easing off of London stocks, and this has helped in a large measure to pull down the prices,

It should also be remembered that, however small the output of consolidated mines, the weekly or monthly production, with the amount of labor and the excellent mechanical appliances at command, must have a very considerable effect in adding to the "pool" stocks in London. A month or two ago the output was something like 5,000 karats per day, which is a comparatively small total when the extent of the company's holdings is taken into consideration. Since then a slight reduction has taken place, and there is, judging by the state of the market, every justification for a still further restriction in the output which is contemplated. After all, although there has been so sudden and rapid a fall in the prices, amounting, it is said, to at least thirty per cent., it should not be forgotten that we are on the threshold, as it were, of a season in the trade, which is periodically dull. Last year about this time there was a greater stagnation in the market than has yet been experienced since the present drop began. The large diamond cutters and dealers were toward the end of 1889 practically "frozen out," owing to the heavy losses they had sustained, and goods fell from 42s. to as low as 30s. and 31s. per karat, which as regards "pooled" diamonds is rather below current rates. The result was, that there was a considerable rush in London and amongst Continental manipulators for parcels of small stuff to keep their workmen employed, and maintain their trade connections to some extent. This demand has ceased for the time being, just at the same period when the large American buyers have also taken wing.

The world's stock of diamonds must have increased enormously during the last fifteen years. In 1876 the output of the South African mines was about 1,500,000 karats. This year it will be over 4,000,000 karats, and the great trust which controls all the principal mines asserts that it has 16,000,000 karats in sight at the present time. Meantime the demand for diamonds has greatly increased, and despite the local depression, they are higher to day—partly because of trust and also partly because of increased demand—than they were two years ago. In one respect the diamond industry is different from all others. Its product—that is, of gems—is never consumed. Of gold and silver a much larger amount than most people would believe is literally consumed in the arts past recovery; but a diamond once cut goes into the world's great stock and is liable to come upon the market at any time. Hence the world's annual taking of diamonds, which appears to be steadily increasing even at advancing prices, is an index of how much of its surplus earnings it can afford to expend yearly in this particular form of luxury. The romance of diamond mining is, of course, all gone. It is now a matter of excavating vast beds of blue clay by machinery, washing it and sifting out the diamonds which, after being roughly sorted for size, are sold in bulk by weight. The men who do the actual work are mere laborers, and their pay is accordingly small.

MOORE & HORTON,
MANUFACTURERS OF
SOLID GOLD JEWELRY,
No. 11 Maiden Lane, New York.
Fine Imitation Diamond Goods a Specialty.
Selection Packages sent on Application.

N. SCHWARZ,
MANUFACTURER OF
VELVET AND LEATHER CASES,
866 Broadway, New York.

A. J. GROENMAN & CO.,
DIAMOND CUTTERS,
80 Nassau Street,
NEW YORK.
SMALL MELEE A SPECIALTY.

MAXHEIMER & BERESFORD,
MANUFACTURERS OF
FINE DIAMOND JEWELRY,
No. 3 Maiden Lane, New York.
ORDER WORK A SPECIALTY.

AIKIN, LAMBERT & Co.,
23 Maiden Lane,
NEW YORK,
Manufacturers and Exporters of
Fine Gold Pens, Pencils,
TOOTHPICKS, HOLDERS,
And Novelties in Silver, Pearl, &c.

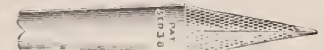

THE BEST FOUNTAIN PENS.
New Assortments in SHOW CASES and FANCY TRAYS for JEWELERS.
Price Lists and Catalogues for intending Purchasers.



Also American and Swiss Watches.
DIAMONDS, Loose and Mounted,
Gold and Silver Thimbles,
CHAINS and JEWELRY in New and Staple Patterns.

HENRY TROEMNER,
No. 710 Market Street, PHILADELPHIA.

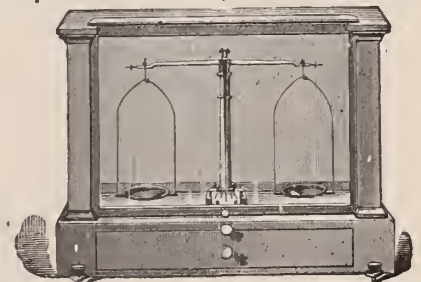

Manufacturer of FINE GOLD SCALES and DIAMOND SCALES.
Bullion Balances and Weights, in use at all the U. S. Mints and Assay Offices. Priced Catalogue on application.

Advice to Watchmakers' Apprentices.

BY A MAN WHO HAS WORKED TWENTY YEARS AT THE BENCH.

The Necessity for Good Working Drawings—Some Preliminary Instructions—The Necessary Tools and Materials.

THERE is no more efficient way for a watchmaker or jeweler to convince the public of his skill and competency than by exhibiting neat and carefully made drawings of jewelry or parts of watches executed by himself. There are many of our younger workmen who would like to make such drawings, and who will be glad to learn how to set about it.

For this reason I will give a few primary hints about the instruments necessary for making working drawings of any mechanical device that it is important for a workman to thoroughly understand, as well as about the needful materials, their preparation, and the way in which to use both.

It is not imperative to have an expensive set of drawing tools in order that nice work may be accomplished. For a watchmaker's or jeweler's purpose a board 18 by 24 inches is quite long enough—indeed one 15 by 20 inches might answer every purpose. It should be made of the best, clear white pine, with two cleats on the back to prevent warping. Cleats are objected to by some, but I have never known a person who, having once become accustomed to a board with cleats, would use one without. The additional instruments and materials required are as follows: A bottle of Higgin's India ink, a 4 H. drawing pencil, a twenty-four-inch T square, a pair of six-inch parallel rules, a pair of six-inch dividers with extension bar with pencil and pen legs, a pair of 4½ or 5-inch dividers, a drawing or ruling pen, a bow pen, a twelve-inch rule for scale of parts, a six-inch protector, three or four sable pencil brushes in quills, four tubes of moist water colors, some glue, a bristle brush and some drawing paper.

The pencil brushes are for washing in colors to represent steel, brass, jewels, etc. The selection of the drawing paper is important, as a poor, cheap paper will not permit of nice work. The kind known as "hot pressed" is the best paper to use; and always select the medium weight. The glue should be prepared the night before the drawing is to be made. Soak the dry glue over night in cold water, using just enough water to cover the glue. In the morning place the dish containing the soaked and swollen glue, in a vessel of boiling water and the heat will cause the glue to dissolve almost immediately. To be in proper condition for working the glue should be of such consistency that when a little is taken between the thumb and forefinger and the thumb and forefinger separated, the glue will rope—that is, draw out in one thread.

Having the materials all ready we will proceed with the preparations for drawing. We will cut a piece of paper a very little smaller

than our 18 by 24-inch board—say 17 ½ by 23 ½-inches. Now we will take a clean, soft sponge dipped in clear, luke warm water and pass it rapidly over both sides of the paper to dampen it. We next remove all surplus water with a piece of an old soft cloth. Next, with a small bristle brush, we will cover a strip of about half an inch all around the edges of the paper with the hot glue. Now we will press the glued edges of the paper down on the face of the drawing board, using a clean cloth to avoid soiling the paper, and then lay the whole face-downward on a perfectly flat table which has been covered with something that will protect the surface of the paper from dust, and leave thus for some time to dry.

The best method, however, is to have two drawing boards of the same size and to prepare a cushion made of eight or ten sheets of the thickest blotting paper cut to exactly the same size of the drawing boards. To use this arrangement place a sheet of drawing paper on the drawing board, after having carefully glued the edges in the manner described above, and lay the board down flat with the paper uppermost. On the drawing paper place a sheet of thin, clean paper and lay on top the sheets of blotting paper carefully spread out in such a way that the edges will be even with the edges of the board. On top of the blotting paper now place the other board and clamp all together with ten small iron screw-clamps and leave for two or three hours in a warm room to dry. When the boards are separated the drawing paper will be found stretched as smooth and flat as the head of a drum and in prime condition for use.

I have mentioned colors for washing in. They are very useful in making drawings, as they enable one to distinguish at a glance the different materials that will be used in the manufacture of the article drawn. For instance, in drawing a duplex escapement we represent a brass escape-wheel and steel pinion and balance staff with ruby jewels. To do this we outline the work with India ink and fill in the proper places with colors that have relation to the colors of the materials to be used—blue for steel, yellow for brass and carmine for ruby jewels. If we use the ordinary India ink in drawing the lines and are not very careful in washing in the color, the India ink will wet up and mingle with the color. To prevent this use Higgin's India ink, which will not wet up with washes; although it does not work so pleasantly nor make such clear, smooth lines as other ink. By laying out the work carefully, though, with a fine hard pencil, washing in the color and then going over the drawing with India ink lines we can get a good clear looking drawing and avoid the danger of the lines running. In making a drawing the lines should always be clear and sharp—not ragged and broken.

Wash the color over the open space by first following the outline with a brush, and then with quick, broad strokes covering the open part. To clean up or make the outline look smooth, work the outline of the figures with India ink.

These washes of color require very careful treatment. More than enough color to do the work is mixed in small earthen plates. A pencil brush of the size proportionate to the job is taken, filled with color, and after having been pressed against the edge of the plate to expel any excess of color, then passed with a rapid touch over the part to be colored. It is only by rapid execution that we can obtain an even tint. It is, therefore, good practice to lay out figures, such as circles, squares, triangles, stars, etc., and fill them in with color.

After the drawing is finished be careful about removing the drawing from the drawing board. Do not try to peel it loose, but cut around just outside the place where the glue attaches it to the board. The strip of paper left glued to the board should be washed off with warm water and a sponge.

I want to call attention to the points of the dividers. They should be fine and sharp, and puncture the paper with the smallest possible holes. If the points of the dividers are hard they can be sharpened with an oil stone slip; if soft, a fine file will answer.

This is enough about preliminaries. In the next article I will give directions for drawing duplex escapements with rules for drawing the angles and properly placing the several parts. And I earnestly hope that every reader will take the trouble to follow the directions by making a careful drawing. It will aid him in understanding the principles involved and will be a piece of work that he will be proud to show to his patrons and friends.

Making these drawings is not so difficult as might be imagined if care be taken and conscientious work done. Of course practice, not theory only, is necessary; and only by putting into practical use can these directions and those that will follow be of service to the reader.

To Remove the Rivet of a Pin Tongue.

A CORRESPONDENT, Mr. H. Carpenter, of Flushing, N. J., sends us the following:

Some workmen have the habit of forcing the rivet in tightly and then filing the ends smooth with the joint. This, of course, makes a clean looking job, but it causes a great deal of trouble to the workman who next has to repair it. When I get such a piece of work I take a pair of parallel pliers and press the joint where the rivet is, tight; thus, of course, stretching the joint slightly. After this the rivet can be removed without damaging the article. Should it be impracticable to use pliers, I rub the part affected with a burnisher. This is also applicable to case joints. I remove the plugs, ascertain where the joint pin is and burnish over the tight spot. I am careful, however, not to rub over the places where the plugs enter.

SOUTH BERWICK, Me., Jan. 26, 1891.

I am pleased with your journal and would not want to do business without it.

L. E. HANSON.

F. & B.

LET THE FIGHT GO ON. The war between SEAMLESS and GOLD SOLDERED CHAINS will prove one of two things, either Seamless Wire is as good as Gold Soldered, or Gold Soldered is as good as Seamless.

A Dutchman offering a horse for sale was asked if the horse had the heaves. "I don't know," said the Dutchman, "but if de heaves are goot for de horse, de horse got 'em." If "Seamless" or "Gold Soldered" is good for chain, we've got 'em or can get 'em. We are making an honest, well finished chain of such good soldered wire that the seam cannot be found, and one that will wear ten years. The whole question is, who puts gold enough on their wire to make a good wearing chain? Some do and some do not. We make a finely finished chain of good, heavy, gold plated wire. Our chain will wear for ten years. We put our stamp on them which is a guarantee that the goods are right. The ten year chains.

Call for our Solderless Locket, made from stock that is as hard as it comes from the rolls, no solder used and the stock is hard and smooth.



THE WASHINGTON BRACELET.

Our "Washington Bracelet" is one of historic value. It shows a fine medallion of Washington, dates of his birth and death, dates of service as President, his seal, the original flag, his coat of arms and crest (from which was conceived our national flag), and the names of the thirteen original states.

We make a large line of Locket and Charms, Chains in Vests, Dickens and Victorias, Neck Chains, Bar Pins, Jersey Pins, Stick Pins, Initial Scarf Pins, Initial Bangles, Chain Mountings, Bracelets, Garters, Interlocking Glove Buttoners, Bead Necklaces and Earrings.

FOSTER & BAILEY,

PROVIDENCE, R. I.

Improved Click

IN these days of stem-winding watches, says W. D—r in *Allg. Journ. d. Uhom.*, ladies' watches frequently come to the repairer's bench with broken click. These clicks are of the

shapes shown in fig. 1, and the break has taken place every time in the direction of the dotted line *ab*. But the space in the bridge

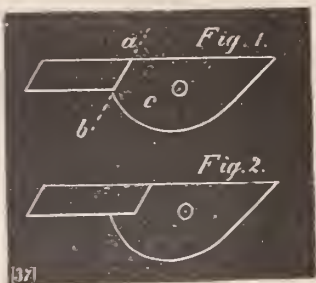

permits of giving a greater strength to the weak part *c*, so that its thin part passes beyond the ordinary place of fracture, whereby the click assumes the shape shown in fig 2. A glance at figs. 1, 2, will show that the click becomes stronger thereby at the dangerous place and, when tempered to a degree of hardness equal to that of the blue color, it will not break so readily. The writer of this has for years made the clicks shown in fig. 2, and he has never yet seen a broken one.

Steady Rate.

IT IS not altogether the great or small loss or gain of a chronometer or watch which establishes it as "good" or "bad," as the case may be, but it is the steady rate of the timepiece that establishes its character; and there is considerable misapprehension on that subject. A small average *daily* rate is often accepted as evidence of good running, whereas that has no bearing in considering the question. Steadiness of daily rate is the quality required. The amount of the daily rate is a mere matter of regulation. A chronometer might average a daily gain of three-tenths of a second, or less, for any given period, and yet run very poorly because of great fluctuations in the daily performance. In all trials of chronometers or watches it is this great quality of uniformity in daily, weekly, or monthly rates which is determined, and the amount of the rate has no effect on the result. A correspondent asks whether a chronometer with a loss of three-tenths of a second per day has a good rate—it is doubtless a fair rate, although it can, of course, be improved; but a uniform rate of three-tenths of one second per day is one which is barely possessed by two per cent.

A Snaky Fad.

WITH Sarah Bernhardt came the trail of the serpent. Already are the vipers started in the show cases and the talk is of a boom in snake jewelry with gem-set eyes. While the divine Sarah toys with the genuine article in her impersonation of Cleopatra, the fair women in her audience may emulate her example with harmless but costly affairs from the jewelers shops. We have now snake bracelets to wind about the bare arms, and snake necklets will doubtless follow to clasp white throats. Snake rings are legion and, given a little time, the Egyptian serpent in precious metals will entwine round coiffures, loving cups, cane and umbrella handles, riding whips, etc., *ad nauseam*. In a show window on Broadway is displayed a unique case in serpentine shape, covered with snake skin and full to bursting with snake rings of divers kinds. But will the boom last? Who knows? On her last visit to America Mme. Bernhardt revived for us the girdle which our women have worn ever since—in fact, are still wearing.

MENDOTA, Ill.

I cannot miss a single copy of THE CIRCULAR.
H. H. TRUCKENBROD.

ALVIN MFG. CO.,

Silversmiths,

860 Broadway, New York,

206 Kearney St., San Francisco.

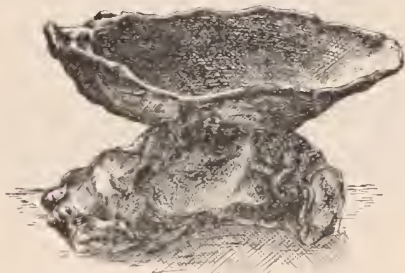

DESIGN—OYSTER SHELL—SALT.

MADE IN LARGER SIZES FOR ASH TRAYS, &c.

Design Patented.

TO THE TRADE.
FINE WATCH REPAIRING

BY **JOHN C. SIMMONDS,**

15 JOHN STREET, NEW YORK.

New pieces, such as Chronometer Locking Springs, Balance Staffs, &c., made in the best styles. Watches sprung and adjusted to temperature and positions.

LEWIS BROTHERS,

Easter Novelties in Silver,

41 Maiden Lane, N. Y.

THE WALTHAM SCHOOL OF HOROLOGY,

D. D. PALMER, Teacher and Proprietor.

Best Advantages in the Country for Horological Instruction.

All branches under the personal supervision of D. D. PALMER, for a number of years in charge of the Adjusting Department of the Waltham Watch Co. POSITIONS GUARANTEED TO APT PUPILS. For terms and other particulars, address

D. D. PALMER,

WALTHAM, MASS.

Specialty of Difficult Repair Jobs.

KEY CHAINS.

ROBT. H. INGERSOLL & BRO.,

65 Cortlandt St.,

Send for List.

NEW YORK.

THE BOWDEN
Seamless Plain Ring,

IS MADE ONLY BY

J. B. BOWDEN & CO.,

Makers of FINGER RINGS of every Description,

COR. BROADWAY & JOHN STREET,

NEW YORK.

ESTABLISHED 1834.

G. & S. OWEN & CO.

MAKERS OF

FINE JEWELRY,

Lace Pins, Ear Rings, Scarf Pins, Sleeve Buttons, Sash Pins, Collar Buttons, Bracelets, Studs.

All Goods sold by us are exclusively of our own manufacture and are warranted 14 K. Fine, and stamped as such when possible.

No. 3 MAIDEN LANE, NEW YORK.



To Strip Gold.—To strip gold from a gilt article and to recover the gold, put the article in strong nitric acid mixed with a little common salt. Leave until the gold is removed. The moment the gold is stripped remove the article, then evaporate the solution to dryness, and swell the residuum with potash or soda. The quality is improved by melting three or four times and adding a little nitric acid each time. Roll out to the required thickness for oride.

Artificial Whetstones.—A French technical paper gives the following method of making artificial whetstones: Gelatine of good quality is dissolved in its own weight of water, the operation being conducted in a dark room. To the solution is added ½ per cent. of bichromate of potash previously dissolved in a little water. A quantity of very fine emery equal to nine times the weight of the gelatine, is intimately mixed with the gelatine solution. Pulverized flint may be substituted for emery. The mass is moulded into any desired shape, and is then made solid by heavy pressure. It is dried by exposure to strong sunlight for several hours.

To Silver Articles.—Freshly deposited chloride of silver well washed with hot water is mixed in equal proportions with table salt and cream of tartar until it becomes a batter. Add water if necessary. The article to be silvered is first cleansed with a good stiff brush and a solution of soda and soap, thoroughly rinsed to remove any dirt, and again rinsed with hot water. It is well to submit it to a dry cleaning with pulverized and washed chalk, pumicestone powder, or quartz powder. When well rinsed with cold water make a ball of loose cotton wrapped in soft muslin and with this coat the wet article with a thin layer of salt. Rub some of the silvering batter on it until the whole article under treatment is well silver-coated. When done, rub quickly with a little ball some cream of tartar upon the silvering and wash.

To Design for Engraving.—In designs for engraving on bangles and other articles where the monogram must be small, if the last initial is the most prominent letter in the monogram it makes no difference how it obtains its prominence, or whether it is so in more than one particular. In drawing monograms of larger size for such a purpose, or engraving upon a watch-case, it is proper for the last initial (that of the surname) to be drawn in the designs so as to be prominent as to both size and finish. This, however, is not more arbitrary than any other rule. If an elegant-appearing combination is evolved from the artist's fancy in which prominence to the surname initial is given in only one direction, that may be considered sufficient. The first letter, where practicable and without the sacrifice of any special beauty, is usually made the most insignificant in the design.

ESTABLISHED 1873.



If for any reason you should desire the services of an AUCTIONEER, and will write me as to the amount of stock you have on hand and its general character, the size of your store and the number of inhabitants of your town or city, I could, from my extended experience, give you an idea of the amount of business you could expect under the circumstances, and, no doubt, be able to refer you to some one for whom I have sold under conditions similar to your own.

As a general reference, you could hardly find a wholesale jeweler who is not familiar with some of the numerous successful sales I have made.

I have made many successful AUCTION SALES, and have yet to record a failure to fully satisfy the owners. Can give you hundreds of references to that effect.

If the business should be urgent and I am myself engaged, I have two competent assistants instructed in my methods whom I could send on short notice.

Any correspondence with me will be strictly confidential in every case.
P. O. Box 2775.

NEW YORK CITY.

WE DESIRE to call your attention to our large and varied assortment of

Complicated, High Grade Gentlemen's and Ladies'



In Gold Cases, both Plain and Enameled, in Choice Designs.

THE LARGEST STOCK EVER SHOWN IN THIS COUNTRY.

NON-MAGNETIC WATCH CO.

OF AMERICA,

CHAS. McCULLOH, RECEIVER,

177 Broadway. = = NEW YORK.

BOOKS FOR JEWELERS.

W. B. DICKIE,

67 William Street, New York,

PUBLISHER OF

Improved Watch Stock Book

— AND —

Improved Watch Repair Book.

SEND FOR DESCRIPTIVE CIRCULAR.

806

806

HOLLINSHED BROS.

Wholesale Dealers in

American Movements

And CASES.

A Big Line of JEWELRY.

809

CHESTNUT STREET,
PHILADELPHIA.

806

USE THE 

AMERICAN MAINSPRINGS

FOR ALL KINDS OF AMERICAN WATCHES.

[FACSIMILE OF WRAPPER.]

1 DOZ. MAINSPRINGS

18 S. E. O. S. 

Extra Quality.

TRADE  MARK.

THE BEST IN THE MARKET.

L. H. KELLER & CO.,

Dealers in Fine Watch Materials and Tools.

Agents for the Patek, Philippe & Co.'s Watches.

64 NASSAU STREET, NEW YORK.

 Geneva Optical Co.,
MANUFACTURERS OF
Spectacles, Eye
Glasses, Lenses
and Cases.

23 WASHINGTON ST.,
CHICAGO.

WOOD & HUGHES,
Sterling Silverware Manufacturers.
New York Agents for the Derby Silver Co.'s
FINE QUADRUPLED PLATED WARE.
No. 16 JOHN STREET, - NEW YORK.
206 Kearney St., San Francisco, Cal.
HASKELL & MUEGGE, Agents.

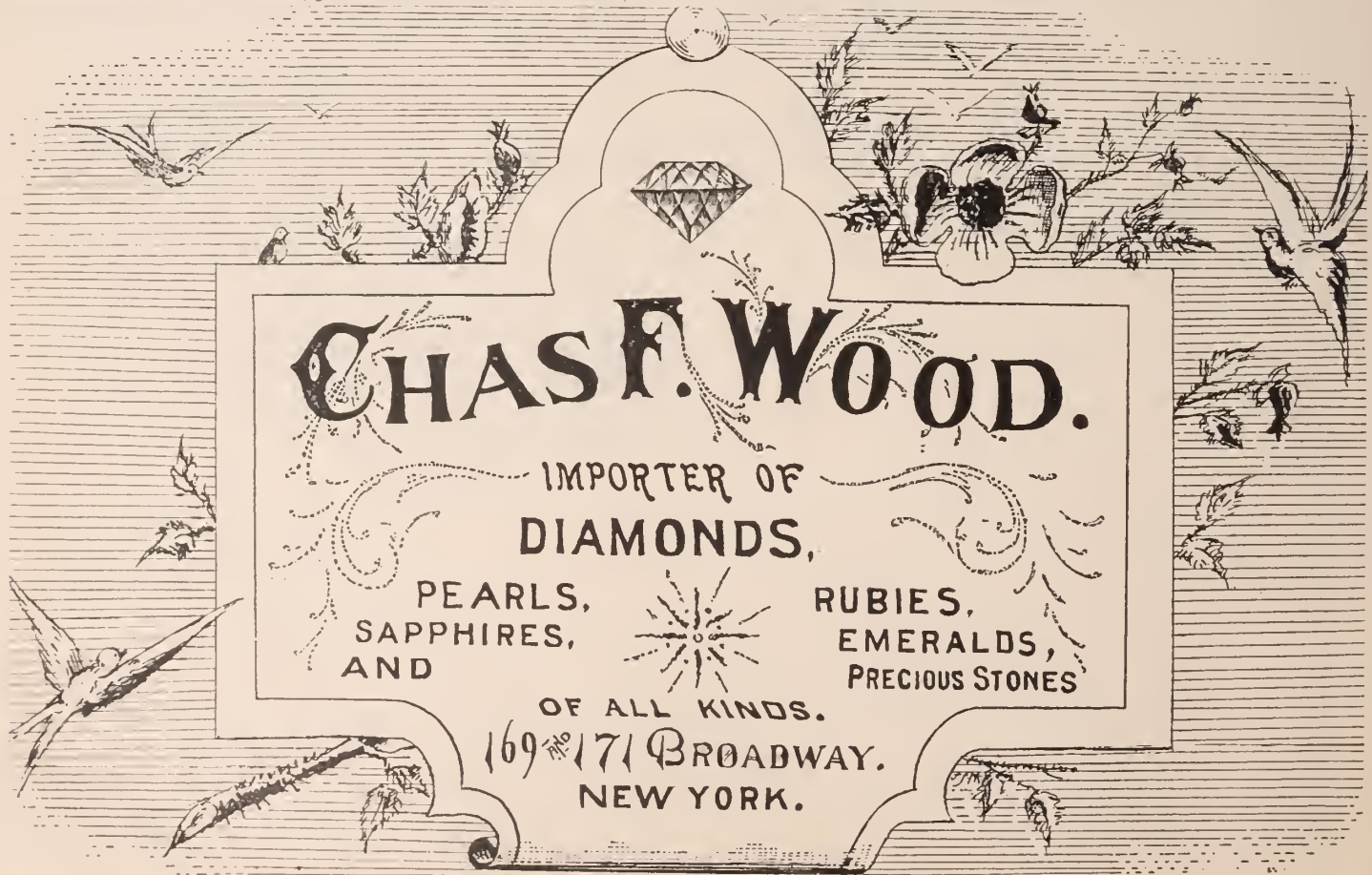

CHAS. F. WOOD.

IMPORTER OF
DIAMONDS,

PEARLS,
SAPPHIRES,
AND

RUBIES,
EMERALDS,
PRECIOUS STONES

OF ALL KINDS.

169 ⁷¹⁰ 171 BROADWAY.
NEW YORK.

every man of us should worship. That is the jewel which we should seek to polish, aye, even to the top of the head, like my friend there and myself. (Laughter.)

Now let us see what else. Oh, jewels! I have no knowledge of jewels, and I remember how foolish it was when a man in Virginia, where I was born and raised, plunged into an unknown stream, and he paid dearly for his floundering. I do not want to be floundering myself? I recollect two instances—one, a man in Boston, now living, a man of many millions. I found him one evening when we supposed he was reading his Bible—I found him studying his jewels, and he said to me, "Bryan, the greatest ecstasy that I enjoy in life is taking out my purse and studying these sapphires, emeralds and diamonds, studying them and loving them as I do here." The other instance was a person whom you all know, passed away a few months ago. He had worn a great diamond right here that filled the whole breast pretty nearly, and it was larger than it was pure, I assure you. It was not a very heavy diamond. I said to him once, "Mr. Jennings, why in the name of heavens do you put on that thing—it isn't a real diamond; it hasn't the appearance of a real diamond?" "Oh, yes," says he, "it isn't of the finest water; it is ugly, but still I like it, I love it, and whenever I look at it it seems to have eyes, and it looks right at me." It made me think of the old oyster man who fell in love with a girl that was anything but handsome. He said,

"She isn't exactly a beauty,
And also she uses a crutch,
But the eyes of that dear little cripple
The heart of an oyster would touch."

(Laughter and applause.)

Now, I believe that about ends the notes. Well, one word about the World's Fair. By the way, when the toast master asked me to speak, in my dilemma, I turned first to the right and then the left, and said, "In the name of Heaven give me something to talk about. They tried to think and they really prompted me from the beginning. President Palmer and myself were the other night engaged until after midnight, and we stayed up until Sunday morning; we made speeches on Sunday, the first violation of the Sabbath that we were ever guilty of, and then we went home to prepare ourselves for the Sunday lesson. President Palmer went diligently to work and so did I, and we got our respective families to study about jewels, because we had a sort of presentiment that we were coming here to speak about jewels, and he got ahead of me. He has been studying the bible ever since on jewels, and he said to me, "Bryan, if we are going to that place, you sit close to me. I thought he was going to prompt me, but absolutely he stole my thunder and he gave every bit of allusion to jewels that could be found. (Laughter and applause.) Now, I say that any man who can be sufficiently adroit to accomplish that over a well trained ex-lawyer, an antiquated lawyer—any man who can accomplish that, who is at the head of the World's Fair will insure its triumphant success. (Applause.) I assure you we have encountered difficulties from the first moment that we started that great ball rolling. We have had difficulty after difficulty, obstruction after obstruction, and but for young blood, and such blood as the young have, earnest, persistent and indefatigable, we would have been squelched ere this. But every obstacle we have met and surmounted one by one, like billows leaping over the golden strand to success. If you gentlemen will only make such an exhibit as is commensurate with the occasion and worthy of your noble association, success is absolutely assured beyond human contingency. (Great applause.)

Introducing the next speaker, Assistant State's Attorney Charles G. Neely, the toast-master, said:

GENTLEMEN: There is one department of this association that has not been called nor recognized to-night, viz: The National Association of Jobbers; and I notice that we have in the company the distinguished chief Assistant State's Attorney. I have the pleasure of calling upon Mr. Neely to respond to such toasts as he may select.

REMARKS OF CHARLES G. NEELY, ESQ.

MR. TOASTMASTER, GENTLEMEN OF THE JEWELERS' ASSOCIATION: I do not conceive how any man with a heart

that beats in his bosom, and blood that runs through his veins and arteries, could have partaken to-night of the banquet spread here, and have listened to the sentiments which have been uttered by gentlemen who have preceded me, could decline, though without being prepared, without notes, to respond to so complimentary a call. We have listened to what jewelry has done to beautify the world, and to make the homes of men happy. But there has been a line of thought running in my mind which has sent me to reflecting in this way—that there are words that are types that stand for thoughts and for ideas, and while to-night every compliment has been paid to the skill and genius, or beauty of jewelry, there have been many things said which indirectly turn the thought upon that chiefest jewel, that highest ornament of a man, of a city, of a nation, namely, a true and loyal heart in the breast of an honest man. (Applause.)

Gentlemen, I have been thinking to-night of the many occasions which you have gladdened by your skill and genius. I can see you now presiding at anniversary occasions, births, marriages and anniversaries, commemorating great events, and it seems to me that a story which I once heard of a little child is appropriate—and, by the way, little children are the brightest, the purest, the sweetest types of innocence that the world has ever seen; and I tell this story as adding, by the way of a child's lips and heart, to the splendid utterances of oratory and thought.

A gentleman was driving in the central part of this State with a little girl, and going up on some of those large rolling, billowy swells of this Prairie State, the child said to the father, "Father, notice how the sky comes down to the earth;" and the father said, "My child, the sky does not come down to the earth, you are deceived. That is the horizon, the limit of the view of your eyes." The child still insisted that the skies came down to the earth, and finally said with persistence, "Father, let us go and see how the skies are fastened down to the earth." The father further explained that there was no coming of the skies to the earth, or fastening of these curtains there; but the child persisted, and he finally gave over and concluded that the child was right and the skies were fastened to the earth.

As I have listened to-night to the speeches I have thought how in the hills are buried away for centuries from the sight of man the jewels which have been dug therefrom, polished and bright until they have caught the fiat of the Almighty when he said, upon the dawn of creation "Let there be light," and of the thousands of diamonds set in clusters of stars and crowns of jewels, polished from the rude earth and refined of dross, that have caught that fiat, flashed the light that made creation bright and silvered the earth. (Applause.)

Gentlemen, your profession typifies more of the art of usefulness, more even of the art of beauty. It typifies the art and genius of solidity in your solid gold. It typifies beauty and ornament in the refined and polished jewels. It typifies the truth that is in the earth, in the light that the diamond catches and flashes; and your profession typifies friendship and love by the Christmas gift, and we carry the memory of our friend, not upon our sleeves, but in the remembrance of the diamond and the cluster at the throat. Gentlemen, you typify by your profession the highest jewel that shines in any firmament, namely, truth. I do not know that it interests you so much as it has me, but it seems to me that if there is any profession, skill or art where all the dross is worn away, and by the refining processes the true worth indeed of every truth of the material world, is made to stand before the eyes of men, it is the profession, the skill and art of the jeweler.

One word more, gentlemen. We have enjoyed together to-night a banquet; we have listened to speeches that have been spoken from the heart, but there is another thing which we have enjoyed, which to me is the rarest jewel known to men—an opportunity to look into each others' faces and to know each others' hearts. You have heard some friend say, when he had been away for some long summer's journey, that he had stood upon some mountain top and witnessed some beautiful sunrise or sunset. He has told you of his view when he looked upon the Northern light. But I say to you to-night, in memory of the hour which you have enjoyed here, that there is no view, there is no height, there is no Northern light that is so rare, so true and precious as a glimpse into

the heart of a true man whom you love, one for whom your friendship has grown, as one has said like the oak in rings around the heart.

Gentlemen, I congratulate you upon your profession and upon the beauty which you give to the world, the truth which you exemplify and the majesty of your skill and art in setting before mankind the true worth of the material world. Which grateful for the work done upon it, flashes back the light of friendship and the love of living hearts. I thank you, gentlemen. (Great applause.)

Judge Driggs then resigned the gavel to the President with the following remarks:

GENTLEMEN we have had a happy evening, and we are now about approaching that season described by Lamartine as the serene and quiet hour when the secrets of a soul escape, and in that hour, out of the abundance of my heart I tender to each and all of you my sincere thanks for the honor which you have conferred upon me, and now have pleasure in returning this gravel to your president.

The president then thanked the assembly for their attention and declared the banquet at an end.

The banquetters in the numerical order in which they sat at table were:

M. N. Burchard, Hon. De Witt C. Cregier, Hon. George Driggs, L. W. Flerskein, Hon. T. W. Palmer, Rev. N. P. Hillis, H. F. Hahn, F. G. Morse, J. S. Runcells, Dr. J. W. Ladd, H. S. Peck, Otto Young, St. John Day, Francis W. Walker, Thomas B. Bryan, Benj. Allen, A. Hart, E. W. Gillett, J. B. Nellagar, Wm. M. Alister.
O. Locket, C. G. Neeley, C. H. Penny, C. K. Giles, F. B. Rice, E. St. John, R. A. Scovel, E. Dickinson, T. K. Webster, J. V. Ridgeway, Wm. R. Kerr, H. A. Kellan, Wm. Gilmon, Geo. T. Boggs, C. F. Happel, James M. Shepard, J. Schnering, T. H. Purple, A. Miller, Peter Lapp, G. J. Correy, Albert Hall, E. A. Dowarce, Paul Juergens, W. H. Gleason, I. S. H. Levy, C. R. Matson, S. Anderson, F. G. Thurley, Jr., G. W. Church, C. A. Sanders, I. H. M. Carle, F. J. Talbot, E. D. Barnum, O. W. Wallis, L. A. Tallman, D. W. Smith, John F. Morse, J. S. Townsend, Edmund A. Parpe, M. Ellhogen, G. P. Titus, A. Hirsch, Kenneth Barnhart, S. Stein, H. L. Largel, G. W. Marquardt, Jr., Geo. E. Marshall, L. J. Lake, A. W. Sproehue, W. T. Thompson, F. N. Cook, Geo. Hunter, Geo. Weidig, John M. Cutter, F. M. Sproehue, C. F. Kimball, Wm. Oskamp, Cin., R. A. Kettle, Joseph Sandman, S. H. Hall, S. K. Houston, A. Antesdel, G. H. Harrington, Hon. O. H. Horton, H. E. Howard, J. W. Meacham, A. L. Seacomb, Geo. T. Greenleaf, M. A. Mead, C. E. Graves, Charles H. Furguson, A. T. Evans, C. P. Dungan, H. E. Shehan, C. H. Rollins, A. J. Perry, W. G. Prawl, C. B. Shourds, C. H. Smith, C. A. Walton, Geo. E. Hunter, C. W. Harmon, W. H. Cloudman, L. Manheimer, W. H. Allen, G. C. Manheimer, Sam Joseph, S. S. Lowenber, Thom Rooney, M. C. Eppenstein, Elmer Foster, Col. J. P. Moody, W. Hirsch, A. Seveuriz, F. Lewald, C. E. Bunker, J. M. Joseph, F. C. Williams, H. W. Hahn, A. W. Wilkinson, A. R. Varian, J. B. Wilkinson, E. B. Moseman, H. Oppenheimer, Kansas City; G. Sackett, J. T. Glover, A. Hurd, Henry Fera, W. C. Hull, Wm. Dart, O. J. Pfeffer, W. F. Juergens, Watson J. Miller, Derby, Conn., W. W. Wilcox, J. Watson, N. Y., Geo. M. Wallace, Miles S. Tracy, A. L. Merrick, G. E. Knight, Col. H. R. Corbin, J. J. Jacobs, General Nelson S. Miles, G. A. Harmount.

Lange's Diamonds.

CHICAGO, Ill., January 23.—The testimony was finished to-day in the diamond smuggling case of Lange or Kronberg, the man who tells the romantic story of his former high position in Vienna, and his sudden disappearance from that city to cover up his son-in-law's forgeries. Judge Blodgett, with whom the case now rests, will, it is thought, order the confiscation of the diamonds.

Canadian Jobbers Dine.

Annual Reunion of Canadian Jobbers in American Watches.

A Meeting Precedes the Dinner—M. C. Ellis Elected President—The Queen and the President Toasted—Annexation not Favored.

ON Thursday, February 5, the annual meeting of the Canadian Association of Jobbers in American Watches took place in Montreal. Those present were:

W. E. Boyd, of Levy Bros., Hamilton, Ont.; M. C. Ellis, of P. W. Ellis & Co., Toronto; T. H. Lee, of T. H. Lee & Son, Toronto; W. K. McNought, of the American Watch Case Company, and editor of the *Trader and Canadian Jeweler*, Toronto; Frank Taggart, of the Toronto Watch Case Company, Toronto; Edmund Scheuer, wholesaler and importer, Toronto; Edgar Wills, wholesaler, Toronto; M. Schwob, of Schwob Bros., Montreal; J. H. Jones, of J. H. Jones & Co., Montreal; J. M. Inglis, wholesaler, Montreal; H. W. Patterson, of Smith & Patterson, Boston; A. A. Abbott, Montreal, manager for Smith & Patterson; J. L. Eaves, wholesaler, Montreal; Alfred Eaves, Montreal; A. R. Harmon, Canadian agent for the Waltham Watch Company; E. J. Schofield, Elgin Watch Company; J. H. Noyes, Secretary of the National Association of Jobbers of the United States, New York; George Joseph, of Louis Davis & Co., Montreal; J. M. Grothe, Montreal; J. T. Bolt, Montreal; J. L. Sheppard, Boston.

The chief business was the adoption of an arrangement by which Canadian watch case makers will cooperate with the association, the former to fix the prices on cases.

The election of officers took place and resulted as follows: President, M. C. Ellis, Toronto; Vice-President, M. Schwob, Montreal; Treasurer, E. Scheuer, Toronto; Directors, the officers and T. H. Lee, Toronto, and J. H. Jones, Montreal.

In the evening those present met at the Windsor Hotel, and enjoyed a "feast of reason and a flow of soul." The large round table was well spread and there was no end of enjoyment. All seemed in excellent spirits and everything went off as gaily as the proverbial marriage bell.

Alfred Eaves of Montreal, presided. On his right was E. J. Schofield, Elgin Watch Co., of New York, and on his left, A. R. Harmon, the Canadian agent for the Waltham Watch Co. The toasts which followed were responded to with vigor.

"The Queen" was proposed by Mr. Eaves and drunk by all the members. "God save the Queen" and cheers followed.

"The President of the United States" was proposed by M. C. Ellis. It too, was drunk by all, and the air rang with the strains of "He's a jolly good fellow" and a round of cheers.

"The Canadian and American Manufacturers" was proposed by T. H. Lee, and responded to by Messrs. Ellis, Taggart, McNought, Grothe and Bolt, for Canadian Manufacturers, and Mr. A. R. Harmon, for the Americans.

All agree that the speech of the evening was that of M. C. Ellis, the new president. He spoke on "The Protection of Home Industries" and alluded to the coming Dominion elections. "If we review history," said

he, "we will find that all great and progressive nations have passed through three stages of progress: 1, agriculture; 2, agriculture and manufacture; 3, agriculture, manufacture and commerce. Such nations as Great Britain, the United States, France, Germany, Holland, Belgium and Switzerland, present examples of those which may be said to have reached the final stage. Our own country has reached the second stage and is about to enter the third."

Comparing the respective tariffs of the States and Canada, Mr. Ellis said that while the former had been 44½ per cent. on articles entered for home consumption during 1889, the latter was only 31 per cent. Since the McKinley bill had passed, nobody knew where the tariff would reach. In the first ten years of Canada's protective policy the savings banks' deposits had increased from \$13,000,000 to \$50,000,000. These deposits illustrated the condition of Canadian workmen, and spoke volumes in favor of protection.

"It could be stated," said the speaker, "that Canada's watch-case, silverplate and and jewelry men were turning out goods well suited to the requirements of the country, and of as good average value as the productions of any other country in the world. In each line great things have recently been accomplished. We must keep reaching out for the world's commerce." The speaker complimented Americans for their loyalty to their flag, but stated that Canadians were still loyal to the British Union Jack, and while wishing to do all the trade with the United States that could be done to mutual advantage, it must be understood that they desired no closer relationship politically. (Applause.)

"The Jobbers' Association" was proposed by McNought, and responded to by J. H. Jones.

"The Retail Trade" was then proposed by M. Schwob, and drunk by all.

"Our Guests" was the next toast. It was proposed by Mr. Schwob and responded to by Messrs. J. L. Sheppard, E. J. Schofield, E. Scheuer and J. L. Noyes. In responding, Mr. Sheppard said he felt more like a stranger than a guest. There had been strained relations between him and the government since the passage of the McKinley bill. The whole trouble had been brought out by three Mac's, Sir John McDonald, Mr. McKinley and —— (here he cast a sly look at Mr. McNought)—he would not say anything about the Editor of the *Trader*. (Laughter.)

Some one had made a wager with Mr. Sheppard that he would not get through his speech without mentioning the "Boss" watch cases of which he is a boomer. However, he lost it, as Mr. Sheppard spoke of nickel cases, but did not mention the "Boss."

"The Press" was proposed by Mr. Sheppard and responded to by Mr. McNought. Mr. McNought's speech also was a summing up of the tariff. He was in the position of a man who was a free trader in theory, and at heart a protectionist. He spoke of Canada's endless resources

"The Ladies" was proposed by Mr. Eaves, and responded to by Messrs. Boyd, Taggart, Abbott and Eaves. Mr. Boyd (as usual when "The Ladies" toast comes up) was called on first. He said he found himself in the old predicament. The only trouble was, there were so many ladies to choose from.

The health of the retiring president was proposed by Mr. Scheuer, and fitly responded to by Mr. Eaves.

Mr. George Joseph made a great hit in his humorous rendition of the "Schoolboy's First Recitation." Mr. Sheppard's attempts to speak French also occasioned mirth.

"Auld Lang Syne," sung with arms crossed, terminated a highly enjoyable reunion.

Dueber-Hampden Affairs.

THE annual meeting of the Hampden Watch Co. was held in Springfield, Mass., on February 3, and a reorganization took place. The Board of Directors elected were W. W. Clark, Col. W. A. Moore, and H. W. Harter, of Canton, Ohio; and J. N. Leonard, J. B. Stebbins and James D. Safford, of Springfield. This board elected Mr. Clark President and Treasurer, and Col. Moore, Clerk. Mr. Clark is President of the City National Bank and of the Diebold Safe & Lock Co., Canton. Col. Moore is the manager of the Dueber Watch Case Works, and recently bought the twenty-four shares of the Watch Co. stock held by Chas. D. Rood. John C. Dueber and Mr. Rood retire from active management of the Company.

This change comes about by the financial troubles of the Dueber Watch Case Manufacturing Company. Judge W. R. Day, who was appointed trustee for the syndicate to secure Mr. Rood's claim of \$95,000 against Mr. Dueber and also to secure the citizens who guaranteed the money, holds a majority of the stock, and it was through his vote that the three Canton men were elected. Aaron Bagg and F. H. Harris, of the old Board of Directors, declined to serve longer.

Hereafter the Dueber and Hampden Companies will be separate concerns and will market their products under individual contracts. It is expected that the assignment of the Dueber Company will be raised by Feb. 15. In the meantime the company's agencies in New York and Boston will be closed, as it is the intention of the company to sell their entire product direct from the factory at Canton through traveling salesmen. The offices at Chicago and Cincinnati will be closed later. The factory is now running under the assignee.

Canadian Customs Seizure.

Montreal customs officials have seized eighty-five watch movements imported from Philadelphia. The importers claim that the movements are very low in price because they were purchased at an insolvent sale, and that the invoices, which form the stumbling block, are genuine.

To be Torn Down.

In 1847 the building, Nos. 21 and 23 Maiden Lane was erected; since then it has been perhaps the most prominent building in the jewelry district, containing some of the largest houses in the trade. The leasehold of the property was sold last November, by order of the trustees of William H. Hayes, deceased for \$57,500, to Frank K. and W. H. Hayes, who will erect the new building.

On May 1, the demolition of this building will be begun, to give place to a beautiful eight story structure which will have two elevators and all the latest improvements, and which will be the building *par excellence* of the jewelry district. The plans are now almost completed and will shortly be submitted to the Department of Buildings.

Many of the present occupants have decided upon new quarters. Cross & Beguelin who for twenty-eight years have occupied the store at No. 21 have engaged that part of the premises of Hartley & Graham at No. 17 Maiden Lane, where they will have better light and more convenient accommodations for their numerous customers.

Aikin, Lambert & Co., for ten years at No. 23, will occupy the remaining part of Hartley & Graham's store at No. 19.

Enos Richardson & Co., who have been in the building since its erection, have engaged for one year the offices now occupied by the T. A. Willson Optical Co., 14 Maiden Lane. They will return to No. 23, when the new building is completed.

E. Aug. Neresheimer & Co. have secured the offices until recently occupied by D. H. Wickham & Co., 24 Maiden Lane.

Henry May and Roy & Co. will move to 51 Maiden Lane.

Wm. Kinscherf will move to 63 Maiden Lane.

Jacob N. Bonne, A. Alling Reeves, Traitel Bros., The New York Company, J. Bernstein, Chas. S. Crossman & Co., and A. M. Bachrach, the remaining occupants of the building, have not yet decided upon their new locations.

Levison Caught.

SYRACUSE, N. Y., Feb. 6.—Chief of Police Wright received word from Chicago police department yesterday that they had in custody one Jacob R. Levison awaiting his orders. Levison was arrested at the request of Chief Wright who has several warrants for him, charging him with grand larceny. The warrant on which the arrest was made charges Levison with having absconded with a diamond valued at \$68, the property of Frank D. Enney. Levison has an indebtedness in the city amounting to \$2,200. For a number of years Levison resided at 524 Cedar street in this city, and carried on a business of jewelry peddler. He was always considered honest by those with whom he did business. It has been reported that enough property has been found in Levison's possession to satisfy his creditors here. Deputy Sheriff Kratz started for Chicago after the prisoner last evening.

Chicago.

Giles Brother & Co., of State street, are sending to their customers a handsomely engraved calender called the Phoenix. It has upon it the portraits of fifty of the firm's principal employees.

Charles H. Knights, the prominent State street jobber, started January 30th with his wife and daughter upon a Southern trip. The journey will be extended as far as the City of Mexico. The object of the tour is to benefit Miss Knights' health, and it is taken under the advice of physicians.

Last Week's Arrivals.

I. OLLENDORFF, Pittsburgh, Pa., Metropolitan; J. S. Allen, St. Paul, Minn., Astor House; F. S. Smith, Denver, Col., Normandie House; A. S. Goodman, Philadelphia, Pa., Gedney House; C. T. Moore, Washington, D. C., Astor House; S. Haas, Evansville, Ind., Metropolitan House; I. Gans, Evansville, Ind., Earles Hotel; J. Nordman, San Francisco, Astor House; C. J. Weichel, Scranton, Pa., St. Denis Hotel.

A Camden Jeweler Confesses Judgment.

CAMDEN, N. J., February 3.—In the Camden County Clerk's office, William R. Bennett, a manufacturing jeweler of Camden, confessed two judgments, one in favor of Charles Hollingshead, trading as Hollinghead Brothers, for \$827.31, and the other in favor of B. J. Cooke & Sons, of Philadelphia, for \$465.31.

Our New Year's Greeting to the Trade.

THE LATEST PARISIAN NOVELTY!



A Remarkable Imitation of the Natural Grape in a choice variety of

BROOCHES, LACE PINS, DROPS, SCARF PINS, ETC.

In Bracelets

WE OFFER A NEW AND EXCEPTIONALLY FINE LINE.

→ The General Character of all the Goods shown is of a High Standard of Excellence. ←

CROSSIN & TUCKER,

409 PINE STREET, PROVIDENCE, R. I.

Knothe Committed.

Charles J. Knothe, aged 18 years, for two years engaged as messenger and general assistant in the office of H. C. Hardy & Co., 30 Maiden Lane, was arrested last Friday by Detective McCarthy of Inspector Byrnes' staff on a charge of stealing goods from his employers and receiving goods from Randel, Baremore & Billings under false pretences, in all to the value of \$2,450. He was arraigned the same day before Justice McMahon in the Jefferson Market Police Court. The Justice fixed his bail at \$10,000 and set the examination down for the following morning.

Young Knothe comes from a respectable family and lived with a widowed mother at 327 West 126th street. He was a member of the Young Men's Christian Association, a regular attendant of a Sunday-school, and had the implicit confidence of his employers. But it appears that in the last six months he fell into bad company of both sexes, and he desired to retain a high position in their esteem. He also made the acquaintance of young women of respectability on whom he desired to bestow such favors as theatre parties, drives and the like. He found his income far too insufficient to indulge these desires to his own or his companions' satisfaction; so he resorted to the unique method of pilfering from his employers. He kept this up until Jan. 24, when his employers awoke to the fact. They took an inventory of their stock and found that they had been robbed of goods to the value of \$1,900.

On that day Knothe went to Randall, Baremore & Billings and told Addison W. Woodhull, a clerk, that Mr. Hardy had sent him for a handsome diamond pendant. Mr. Woodhull turned him over to John S. Darcey, another clerk, and as Knothe was known to be in the employ of Hardy & Co., and had been there before on similar messages, Mr. Darcey without hesitation delivered to him the pendant ordered, valued at \$550. Knothe immediately hid him to Simpson's and on the strength of a little note he had himself written purporting to come from a fictitious Mrs. A. J. Short, received \$200. on the jewel. The following day Knothe telegraphed to his employers that he was ill and would not be down that day. On the same day Mr. Woodhull saw Mr. Hardy and asked him his opinion of the jewel. Then the story came out. Mr. Hardy called at the youth's home and learned he wasn't there. The case was given Inspector Byrnes who commissioned detectives McCarthy and Titus to follow it up.

A few days later, A. C. and William Knothe, brothers of the young man received a letter from Charles, in which he stated his crime and asked for money to return to New York. Detective McCarthy arrested him as he stepped off the Barclay street ferry-boat and escorted him to Police headquarters, where he confessed. Eighteen pawntickets, representing goods valued at \$2,450, and on which he got about \$1,200 were found on him.

At the examination, Saturday, Mr. Hardy stated in his complaint that on January 24, and on previous days, fourteen pairs of earrings containing diamonds, and five unset stones, valued in all at \$1,900 had been stolen; and on that day that the defendant had suddenly left his employ under the subterfuge that he was sick. Mr. Darcey's complaint was substantially as above. A. C. Knothe told the Justice that it was the intention of himself and his brother William to make all reparation to the victimized firms, but was satisfied that the law be allowed to take its course. The prisoner confessed that the pawntickets represented the stolen property. The Justice committed the young man in default of \$3,000 bail on the first charge and \$1,500 on the second, this reduction being allowed at the earnest solicitation of Mr. Hardy. The bail is considered very low as both cases are larceny in the first degree.

No Combination to be Made.

During the past two weeks a rumor has gained currency that a combination of clock manufacturers is about to be formed whose intention, so it was said, was to conduct business on the plan of the American Tobacco Co.—that is to unite their plants and carry on business as one conglomerate concern.

The E. N. Welch Mfg. Co., the Seth Thomas Clock Co., the New Haven Clock Co., and the Waterbury Clock Company were mentioned in the deal. Several of the manufacturers were seen by THE CIRCULAR representative, and each pleaded ignorance of the existence of such a combination. The rumor was undoubtedly founded on the fact of a recent meeting of clock manufacturers to consider their mutual interests.

The Sandifer Settlement.

A settlement was concluded last week with the creditors of William H. Sandifer, on a basis of 50 cents on the dollar; 20 per cent. being payable in cash, 15 per

cent. in six months' notes and 15 per cent. in twelve months' note.

Mr. Sandifer made a general assignment on Dec. 26, with net liabilities of \$32,000, preferring M. Fox & Co., who held his note for \$1,500. Louis G. Fox was appointed assignee. Among the forty-nine creditors were Kuhn, Dorflinger & Co., Alling & Co., Hodenpyl & Co., Louis Strasburger & Co., Wm. Downey, D. C. Dodd, Jr., Kremenz & Co., Sidney T. White, Geoffroy & Co., M. Fox & Co., L. W. Fairchild & Co., I. L. Russell, Cory & Osborn, Doty & Andrews, Durand & Co., and Whitehorn Bros., London, Eng. As affairs were expected to be settled shortly, a temporary bond was taken out for the assignee, and no schedule was filed.

The assignee is to be commended for his effectual work, for through his personal endeavors, enough goods were sold to give the creditors a good percentage of the money owed them. The assets at the time of the settlement reached \$30,000.

A Fine Gem.

The lovers of fine jewels have had a treat this week in the exhibition at the Mermod Jaccard Jewelry Co. of a magnificent opal nearly one and one-half inches in diameter, and the stone is of extraordinary lustre and the play and reflection of the prismatic colors was simply wonderful. It is surrounded by a circle of twenty-three diamonds and is said to be the finest opal in America.

Miss Jennie Lowrey, of Flora, Ill., a graduate of the La Porte Horological School is in business for herself and works at the bench. She is said to be a first-class workwoman, and J. M. Cunningham, her competitor for trade, is gallant enough to recommend her workmanship. A daughter of A. Kehl, of Connersville, Ind., is doing watch-repairing for her father and is entrusted with most of the buying. The writer met a salesman this week who admitted that Miss Kehl's bright eyes and merry smile secured better prices from him than her father could have gotten.

WALTHAM DIALS.

WALTHAM DIAL CO.

We desire to call the attention of the trade generally to the fact that they can have duplicated within ten days, at reasonable cost, any kind, shape, size or make of dial. Watch and clock factories supplied with dials for their entire product, or with special designs for their high-grade movements. When large quantities are ordered special rates will be given.

Special attention given to trade-marks, names, emblems, photographs, landscapes. Ornamental work of every description done in black and colors.

WALTHAM, MASS.

WALTHAM DIALS.

New York Notes.

(Continued from Page 34.)

E. J. Zahm, Lancaster, Pa., sailed to Europe on *La Champagne* last Saturday.

The jewelry store at 57 First avenue is advertised for sale.

About May 1, the T. A. Willson Optical Co. will move from 14 to 51 Maiden Lane.

A judgment for \$131.94 is recorded against Charles L. Rabitte in favor of H. W. Pearson.

The firm of Phillips & Co. 2273 Third avenue has been dissolved by mutual consent. Lewis Schoonmaker will sign in liquidation.

Jacob Bunn, Jr., of the Illinois Watch Co., sailed to Europe on the 7th by the *Umbria*. He will be gone two months.

The Julius King Optical Co. have secured a judgment for \$121.19 against John B. Viemeister, Brooklyn, N. Y.

The Wm. L. Gilbert Clock Co. have secured a judgment against Geo. A. & Edmund C. Veimeister, of Brooklyn, N. Y., for \$190.13.

The Seth Thomas Clock Co. have now entirely removed to 49 Maiden Lane, where they have much larger quarters than at 20 Murray Street.

E. & A. L. Fox, pawnbrokers at 168 E. Houston street, were on Feb. 3, sold out by Deputy Sheriff Carraher under executions for \$5,229.

Oliver G. Fessenden and Walter N. Walker, employees of Hayden W. Wheeler & Co., have been admitted to partnership in the firm, the firm name and business remaining the same as heretofore.

The store of Moritz Fuchs, 1447 First avenue, was sold out by Deputy Sheriff Barry, last week, on an execution for \$2,018.96, in favor of Josephine Fuchs, his wife. The sale realized about \$400.

The limited partnership of Bawo & Dotter, importers of art pottery, has been renewed until January 1, 1893, by Francis H. Bawo, Henry Witte and Gustav Otto, general partners and Charles V. Dotter, special partner.

On Friday, Deputy Sheriff Carraher took possession of the diamond-cutting establishment of Ramsgate & Blog, at 10 Maiden Lane, on executions for \$4,270.61 in favor of H. Hemmendinger and \$1,928.99 in favor of Marguerite Blog. On the following day the executions were countermanded at the sheriff's office, the judgment having been satisfied.

The sale of Montefiore Isaac's collection of rare porcelains, antique bric-a-brac, rich cut glass, old English sterling silver and other art wares is now being conducted at the Fifth avenue auction rooms, 240 Fifth avenue. The collection contains a rich assortment of silver spoons, forks, and ladles all of the King pattern and showing the Hall mark. There are also several silver candelabra, and ornamental pieces of various forms and quaint designs. The sale terminates to-morrow.

Joseph M. Bolton, who was indicted some time ago on the charge of stealing from the Gorham Manufacturing Co., was released last week on \$2,500 bail, furnished by W. J. Cromwell of 203 East Sixty-ninth street, Mr. Cromwell swore that he owned the house, 226 East Twelfth street, in fee and his equity in it was worth \$100,000, there being a mortgage on it for that amount. Investigation, however, showed that he had inherited the property from his father, and only a life estate, and practically no fee interest in it. An indictment on the charge of perjury was found against him and he was arrested on Saturday. Judge Martine fixed his bail at \$5,000.

The suit of the New York Standard Watch Co. against Austin Corbin, which has been on the calendar of the Court of Common Pleas for some months, will undoubtedly be decided this week. In the drawing of the lease for the occupancy of the store at 13 John street (Corbin Building), it was set forth that the place would be complete and ready for the smooth conduction of business by May 1, 1889. At that date the Seth Thomas Watch Company occupied the premises though they were unfinished and for some months the work of carpenters, plasterers and other mechanics impeded the progress of their business to such extent that they sought relief in a suit for damages in the sum of \$5,000.

President Burchard.

Mr. Mortimer N. Burchard, manager of Simpson, Hall, Miller & Co's. western house, and president of the Chicago Jewelers' Association, is one of the most highly respected business men of Chicago. His integrity is as sterling as his silverware, and he counts as his warmest friends the substantial and prominent men of Chicago.

Mr. Burchard was born at Moscow, Livingston County, New York, and in 1840 at an early age removed with his father's family to St. Louis. In that city he received the early training which has made him so successful a business man. He is not honest in his dealings, because as an eminent Philadelphia electrician, scientist, printer, and diplomat observed, "Honesty is the best policy," but because honesty is right.

For thirty years, in St. Louis, Mr. Burchard was connected with one house, as boy clerk and member of the firm. In 1883 he was induced to accept the charge of Simpson, Hall, Miller & Company's business in the West, with headquarters in Chicago. He has a beautiful home at Washington avenue and Fifty-second street, in Hyde Park, and his charming family have the pleasantest of surroundings. Mr. Burchard is an honored and by reason of his rare social qualities, a popular member of the Union League and Hyde Park suburban clubs.

R. B. Clark, of Anderson, Ind., has used the \$1,000 which he received from the Jobbers' Association, for reporting a certain St. Louis house for underselling combination prices, to fit up his store in fine order.

President Ellis.

Mr. M. C. Ellis, the new president, is a Toronto man, 34 years old. He is a member of the Toronto Board of Trade and a director of the Dominion Commercial Traveller's Association. He is a practical jeweler having served his time at the bench. He is a partner in the firm of P. W. Ellis & Co., Toronto; P. W. & M. C. being twin brothers. They have a double building fronting on both Wellington and Front streets, Toronto's principal wholesale thoroughfares. They are far and away the largest manufacturing jewelers of the Dominion. Six travelers are employed. The business has two branches, the manufacturing department and the wholesale department, the latter selling American and European goods as well as distributing home manufactures. They are the most extensive Canadian handlers of American movements and cases. They make a specialty of medals, using elaborate die work and costly machinery, and employing skilled labor. Another feature is the "winter sports" jewelry, *i. e.*, toboggan brooches, show-shoe scarf-pins, ice-castle cuff buttons etc. These are made by this firm in very large quantities.

The firm had a small beginning and its history is interesting.

In 1878, P. W. Ellis started with a small factory in Toronto and "M. C." (as he is familiarly called) went on the road with a gripsack. He says "We hadn't as many goods then as would fill a corner of one of our travelers' trunks now. I worked up routes and put on travelers East and West. We put our savings into the business and built it up. We have always aimed to turn out the best goods." The business has moved three times to larger premises since 1878.

The present tendency toward enamelling will probably result in new ribbon brooches. An attractive one seen was of silver enamelled in imitation of a colored satin ribbon carelessly knotted and held together in the centre with a pearl.

A. LUDWIG & CO.

SILVERSMITHS,

(TO THE TRADE ONLY.)

247 & 249

CENTRE STREET

TRINKMAN BUILDINGS,

NEW YORK.

A. LUDWIG, for the past 9 years Designer and Superintendent for George W. Shiebler.

SILVER NOVELTIES

A SPECIALTY.

Designs and Estimates Cheerfully Furnished.



Special Notices.

Rates 75c. per insertion for notices, not exceeding lines; additional words 2 cents each. If answers are to be forwarded, postage stamps must be enclosed. Two insertions, 10 per cent. off; Three insertions, 15 per cent. off; Four insertions, 20 per cent. off. Payable strictly in advance.

Situations Wanted.

THE JEWELERS' CIRCULAR has a guaranteed circulation of over 10,000 copies weekly. It is, therefore, the best medium for reaching the trade. To demonstrate this to advertisers, notices in this column will be inserted free of charge during the month of February.

WANTED.—By a young man of experience, and now in the retail jewelry business, a position with a wholesale house dealing in precious stones or jewelry, or with a manufacturer of fine mountings. In office or to travel. Highest references, given. Age 28 years. Address G. H. C., care THE JEWELERS' CIRCULAR.

YOUNG MAN who understands hard soldering and can do clock-work and watch-work when not complicated, would like to get a position with a first class watchmaker and finish trade. Temperate, honest, industrious and does not use tobacco. Expects a reasonable salary to commence. Have good mechanical ideas. Some tools. Address, F. E. Hackett, Box 476, Baton Rouge, La.

WANTED—SITUATION by a watchmaker with seven years' experience; furnish own tools and is considered a good salesman; would travel for some jobbing house. Address X. Y. Z., care THE JEWELERS' CIRCULAR.

WANTED—A POSITION by a first-class manufacturing jeweler and diamond setter of nine years' experience. All references from present employer. Address A., care THE JEWELERS' CIRCULAR.

WANTED A POSITION AS TRAVELING salesman, by a young man well up in the jewelry business. Well acquainted with Western and Texas trade. A good hustler. Well recommended. Address B., care THE JEWELERS' CIRCULAR.

POSITION WANTED—By an experienced and a traveling salesman; good references given. Address H. F., care THE JEWELERS' CIRCULAR.

WANTED.—Position by a first class watchmaker, clockmaker, jeweler, and repairer of musical toys, etc. Can put my hands to any variety of repairing work. Have had thirty years' experience; can furnish best of references and security if desired. Would prefer a position in New York City or near-by town. Address, D. H. J., care THE JEWELERS' CIRCULAR.

WANTED.—Situation as traveling salesman with reliable manufacturing or jobbing firm. Will carry any line connected with the jewelry business. Good reference, no bad habits, and a hard worker. Seventeen years in the retail business. Address, C. L. James, 17 14th street, Toledo, O.

WANTED.—By a young man of 23, position as assistant watchmaker under finished workman, where I can be instructed on difficult and complicated work. Have had between 2 and 3 years' experience; am strictly temperate, and can give best of reference. Address "L," 224 Main street, Middletown, Conn.

FIRST-CLASS SALESMAN with established trade desires position with manufacturing jeweler or jobbing house to travel West and Northwest or South. Moderate expectations. All references. Address R. M. Buttle, 76 Franklin street, N. Y.

WANTED.—Position by a young man 28 years of age. Has had five years' practical experience in the retail optical business, being able to do all kinds of repairing usually done in an optical store. Can set all kinds of cylinder and compound lenses into both specs and eye-glasses. Have also had two years' experience in fitting ordinary cases of defective eyesight. Would like a position in some established optical house or manufacturing optician. Address K. W. M., care JEWELERS' CIRCULAR.

Help Wanted

WANTED. A first-class watchmaker and engraver. State age, experience, salary expected. Can give to right party a desirable position. Address, Theo. L. Rogg, Des Moines, Ia.

CLOCK MAKER WANTED. To attend to outside work. State experience, references and salary. Permanent position to a satisfactory man. Bailey Banks Biddle, 12th and Chestnut streets, Philadelphia.

WATCH MAKER WANTED.—A young man, good workman, aged about 25 years, to regulate watches; must have good references. State salary expected. A permanent position to the right man. Bailey Banks Biddle, 12th and Chestnut streets, Philadelphia.

WANTED.—A first class, theoretical watch maker to take charge of material department of a New York house. Permanent position, good salary. Address, Watchmaker, care THE JEWELERS' CIRCULAR.

WANTED. Experienced traveling salesman. Address, Oskamp, Nolting & Co., Cincinnati, Ohio.

A YOUNG MAN familiar with silver plated ware, full of push as junior salesman. Address with full particulars giving experience. References, salary expected, etc.. Address B. R., Box 320, N. Y. P. O.

WANTED. A few traveling men who are practical watchmakers, and have the time—to call the attention of the craft to the Mosely Lathe and Attachments, through the East and Southwest. Address, Mosely & Co., Elgin, Ill.

WANTED.—A YOUNG MAN (single) who understands lathe work, engraving and the business in general. Want a man of good habits; must give good references. Address H. S. W. care THE JEWELERS' CIRCULAR.

Business Opportunities.

FOR SALE.—In one of the most rapidly growing manufacturing towns in Pennsylvania. Fine new stock of watches, clocks, jewelry material and fixtures. Trade well established and growing, plenty of bench work. Low rent. Practically no opposition. Will invoice about \$6,500. Stock can be reduced, good reasons for selling. Address, Pennsylvania, care THE JEWELERS' CIRCULAR.

FOR CASH.—A rare bargain, tools, material, and good will of leading repair shop, in a healthy, prosperous, county seat. Two railroads, fine schools, nice stock; would pay handsomely. Particulars on application. W. A. Bethel, Thomaston, Georgia.

ESTABLISHED JEWELRY BUSINESS in manufacturing city on Hudson River, stock reduced. Fine fixtures. Inventory about \$3,000; sell for 25 per cent. less than cost, or will sell fixtures alone. Splendid chance for a good man who is a watchmaker. Address, Spot Cash, care of JEWELERS' CIRCULAR.

THE handsome jewelry and optical business of E. P. Langston at Easton, Md. Stock and fixtures about \$8,000.

For Sale.

FOR SALE.—1. Whitcomb Lathe, Wehster wheel, universal head slide rest, Beach & Snyder chuck, and a full line of split wire chucks, counter shaft, etc. Will be sold cheap. B. H. Coshy, jeweler, Asheville, N. C.

FOR SALE.—A Mosely No. 1, soft lathe with ten chucks, countershaft, footwhale and universal face plate all nearly new. Also one standard lathe cheap. Will trade to buy, or will trade the above for a No. 3, hard American lathe or a watch factory machinist's bench lathe. Address Box 1497, Rockford, Ill.

To Let.

TO MANUFACTURING JEWELERS AND OTHERS.—A floor to let in the new improved factory building, corner St. Marks and Underhill avenues, Brooklyn. Fine light, power and all modern improvements; within twenty minutes of the Brooklyn ferries. Apply to Geo. W. Shiebler, 8 Liberty Place, New York City.

WORK SHOPS to let in the large, new fire-proof building 29 and 31 Gold street, near John street, New York. Excellent light, steam heat, fire-proof vaults, solid floors, elevator, power in abundance. Apply to Chas. S. Platt, 31 Gold street.

Miscellaneous.

W. A. SCHROETER, 108 Grand street, New York City. Estimates rendered on any desired job. Four expert watch repairers employed specially for Trade Work. Guaranteed finely finished at low prices. Also a good chance for a young man to study watchmaking.

W. F. A. WOODCOCK'S SCHOOL FOR WATCHMAKERS, Winona, Minn., offers unrivaled facilities for acquiring a thorough practical knowledge of every branch of the business. Terms very reasonable.

They Forged Orders.

For the past month H. O'Neill & Co., the Sixth avenue dry goods dealers, have been receiving goods which they had never ordered. Seeking the assistance of the police in the unravelling of this peculiar state of affairs, Inspector Byrnes sent last week a communication to Aikin, Lambert & Co., stating that a person was going about the jewelry district presenting forged orders for goods for O'Neill & Co. The firm put themselves on the outlook for the machinator, and the result was the arrest on February 5 of two well-dressed young men, Ernest Belden, aged 18 of Rahway, N. J., a former employee at O'Neill's and Edward Yunker, of this city, at the store of Aikin, Lambert & Co., by Detective Mulvey.

Their plan of swindling lay in presenting orders for goods which were forged even to the printed matter, and, when possible, they would take the goods with them, asking that the bills be sent later to O'Neill's. In several cases the goods were sent direct to the house. The young men had in their possession a number of pawn tickets and blank orders, besides written orders on Aikin, Lambert & Co. and the Gorham Mfg. Co.

Among the houses that suffered through the youths' operations were Byron L. Strasburger & Co. and Levy, Dreyfus & Co. On January 12th Belden presented at the former's establishment an order for one gentleman's 14 carat solid gold stem-winding hunting case watch with Waltham movement, valued at \$35.00, and on the same day Yunker presented an order for two similar watches, valued at \$70.00. They also presented an order for three opera glasses, valued at \$35.00, upon Levy, Dreyfus & Co.

The complaints were heard before Justice Hogan in the Tombs Police Court on Friday. The prisoners waived examination, and were committed in default of bail in the sum of \$500, on the charge of grand larceny.

Samuel Bock Arrested.

Samuel Bock, a jeweler of 11 Mine street, Pittsburg, Pa., was on Monday held for trial in \$500 bail, in the Yorkville Police Court on a charge of stealing a ring entrusted to him to sell on commission by Adolph Cohn, another jeweler, 1442 Third avenue. The defendant is under indictment for a similar offence.

\$2,000 Worth of Goods Seized.

Staff officer Storey and Inspectors Bronne and Donohue of the surveyor's department of the Custom House on Monday seized \$2,000 worth of gold watches and some gold finished fruit knives found on Max Gibbs, said to be a jeweler, of Indianapolis, Ind., who was a passenger on the incoming steamer *Imo*.

A judgment for \$218 is recorded against Caesar A. Cuppia in favor of E. Kearney and others.

CLASSIFIED INDEX TO ADVERTISEMENTS.

All Advertisements are entitled to one insertion under proper heading. Extra Insertions, \$6.00 per Annum. Extra Headings, \$12.00 per Annum.

PAGE.	PAGE.	PAGE.
Assayers & Refiners.	Gold Chains.	Silk Guards.
Howard, S. P., 8 John street., New York..... 64	Beck, J. & Son, 10 Liberty street, New York... 80	Rosentall, Wm., 79 Nassau street, N. Y..... 38
Schawel, John & Co., 29 John street., New York..... 42	Rickert & Stiehle, Newark, New Jersey..... 14	Silver Plated Ware.
Goldsmith Bros., Chicago, Ill..... 3	Horological Schools.	Rogers, Smith & Co., Meriden, Conn..... 8
Platt, Chas. S., 29 Gold street, New York..... 64	Waltham School of Horology, Waltham, Mass. 54	The Rogers & Hamilton Co., Waterbury, Conn. 64
Lelong, L. & Bro., Newark, N. J..... 64	Jewelry and Silverware Cases	Openheim & Zimmern, 46 Maiden Lane, N. Y. 64
Auctioneer.	Schwarz, N., 866 Broadway, N.Y..... 51	Middletown Plate Co., Middletown, Conn..... 5
French, J. H., Box 2775, New York City..... 55	Jewelry Repairers.	Pairpoint Mfg. Co., New Bedford, Mass..... 15
Black Onyx Jewelry.	Wiederhold, A., 20 Maiden Lane, N. Y..... 29	Rogers & Bro., 16 Cortlandt street, New York.. 10
Lawson & Van Winkle, 11 Maiden Lane, New York..... 29	Jewelers' Scales.	Rogers, Wm., Mfg. Co., Hartford, Conn..... 47
Woglom, Gilbert T., 32 John street., New York. 36	Troemner, H., 710 Market St., Phila., Pa..... 51	Sterling Silver Jewelry.
Badges, Medals, etc.	Jobbers, Watches, Diamonds, etc.	Blackinton, R. & Co., North Attleboro, Mass.. 27
Stockwell, E. R. 19 John street., New York.... 43	Bowman & Musser, Lancaster, Pa..... 6	Sterling Silver Novelties.
Books, Stationery, etc.	Conover, D. F. & Co., Cor. Chestnut & 7th streets, Philadelphia, Pa..... 15	Alvin Mfg. Co., 860 Broadway New York..... 54
Challon, Howard, 10 Spruce street, N. Y..... 49	Hennege, Bates & Co., Baltimore, Md..... 27	Lewis Bros., 41 Maiden Lane, New York .. 54
Dickie, W. B., 67 William street., New York... 56	Katlinsky & Gatzert, 96 State street, Chicago.. 43	Sterling Silverware.
Chronometers.	Koch & Dreyfus, 22 John street, New York.... 35	Wallace, R. & Sons, Mfg. Co., 3 Park Place, New York..... 16
Bliss, John & Co., 128 Front street, New York. 28	Myers, S. F. & Co., 48 Maiden Lane, New York. 64	Durgin, W. B. Concord, N. H..... 30
Cut Glass.	Yates, John B., 147 Nassau st., New York.... 24	Gorham Mfg. Co., 10th st. & B'way New York. 2
Clark, T. B. & Co., 53 Park Place, New York.. 35	Cross & Beguelin, 21 Maiden Lane, N. Y..... 29	Ludwig, A. & Co., 247 Centre street, New York 61
Dorflinger, C. & Sons, 36 Murray street N. Y.. 34	Hollinshed Bros., 806 Chestnut street, Phila., Pa. 56	Towle Mfg. Co., Newburyport, Mass..... 35
Mt. Washington Glass Co., New Bedford, Mass. 46	Lorsch, Albert & Co., 37 Maiden Lane, N. Y.. 64	Wood & Hughes, 16 John street, New York.... 56
Diamond & Precious Stone Importers.	Nordman Bros., San Francisco..... 28	Tool Manufacturers.
Hedges Wm. S. & Co., 170 Broadway, N. Y.... 45	Scott, J. T. & Co., 4 Maiden Lane, N. Y..... 45	American Watch Tool Co., Waltham, Mass.... 19
Kahn, L. & M. & Co., 10 Maiden Lane, N. Y. 64	Key Chains.	Chicago Watch Tool Co., Chicago, Ill..... 30
Kipling, E. E., 2 John st., New York..... 64	Ingersoll, R. H. & Bro., 65 Cortlandt St., N. Y. 54	Bullock, O. W. & Co., Springfield, Mass..... 30
Oppenheimer Bros., & Veith, 35 Maiden Lane, New York..... 35	Masonic Emblems and Charms,	Logan, A. J., Waltham, Mass..... 7
Randel, Baremore & Billings, 29 Maiden Lane, 44	Richardson, J. W. & Co., 194 ¹ / ₂ Broadway, New York..... 43	Waltham Watch Tool Co., Springfield, Mass.. 46
Smith, Alfred H. & Co., 182 Broadway, N. Y... 47	Musical Boxes.	Watch Companies.
Wood, C. F., 169 Broadway, New York..... 56	Jacot & Son, 298 Broadway, New York..... 35	American Waltham Watch Co., 5 Bond street, New York..... 23
Kipling, R. A. 31 Union Square, New York... 47	Optical Goods.	Illinois Watch Co., 11 John st., New York.... 50
Diamond Cutters.	Geneva Optical Co., 23 Wash'n st., Chi., 14, 36, 49, 56	Non-Magnetic Watch Co., 177 B'way, New York..... 55
Groeneman, A. J. & Co., 80 Nassau st., N. Y... 51	Order Work.	Stop..... 36
Diamond Jewelry.	Maxheimer & Beresford, 3 Maiden Lane, New York..... 51	Trenton Watch Co., Trenton, N. J..... 19
Falkenau, Oppenheimer & Co., 40 Maiden Lane, N. Y..... 64	Pens, Pencil Cases, Etc.	Watch & Clock Oils
Nissen, Ludwig & Co., 18 John street., N. Y... 14	Aikin, Lambert & Co., 23 Maiden Lane, New York..... 51	Nye, Wm. F., New Bedford, Mass..... 50
Stern Bros., 42 Maiden Lane, N. Y..... 36	Ring Makers.	Watch Keys.
Sexton Bros. & Washburn, 41 Maiden Lane, 14	Bowden J. B. & Co., 192 Broadway, New York..... 54	Clark, A. M., Plainville, Conn..... 35
Engravers and Designers.	Bryant, M. B. & Co., 10 Maiden Lane, New York..... 12	Kendrick & Davis, Lebanon, N. H..... 49
Bartholomew & Peckham, 18 Spruce street., New York..... 49	Haskell, H. C., 192 Broadway, N. Y..... 42	Watch & Clock Dials.
Ryder & Dearth, 146 Westminster street, Providence, R. I..... 25	Hildreth Mfg. Co., 51 Maiden Lane, New York. 49	Waltham Dial Co., Waltham, Mass..... 60
Eye Glass Holders & Chains.	Ostby & Barton, 80 Clifford street, Providence, R. I..... 36	Watch Case Manufacturers.
Merritt, S. F., Springfield, Mass..... 14	Wood, J. R. & Sons, 14 John street, New York. 35	Brooklyn Watch Case Co., 192 B'way, N. Y..... 24
Fancy Goods, Bric-a-Brac, Etc.	Wodiska, Julius & Co., 49 Maiden Lane, New York..... 44	Courvoisier, Wilcox Mfg. Co..... 39
Taylor & Bro., 860 Broadway, New York..... 64	Rolled Plate Chains.	Feinier, G. F., 9 Bond street, New York..... 38
Filigree Jewelry.	Cheever, J. G. & Co., No. Attleboro, Mass.... 45	Essex Watch Case Co., Newark, N. J..... 40
Hartmann, Peter, 36 Maiden Lane, New York. 38	Kent & Stanley, 7 Eddy street, Providence, R.I. 13	Roy Watch Case Co., 17 Maiden Lane, New York..... 47
Gold Jewelry.	Rolled Plate Jewelry.	Muhr's Sons, H., 629 Chestnut street, Phila., Pa. 21
Carter, Sloan & Co., 15 Maiden Lane, New York..... 31	Crossin & Tucker, 409 Pine street, Providence, R. I..... 59	Watch Case Repairers.
Cottle, S. Co., 860 Broadway, New York..... 36	Foster & Bailey, 60 Richmond street, Providence, R. I..... 53	Felix N. J., 71 Nassau street, New York..... 49
Jonas, Dorst & Co., Race street, Cincinnati, O. 45	Plainville Stock Co., Plainville, Mass. 43	Henry, Peter, Cincinnati, Ohio..... 25
Larter, Elcox & Co., 41 Maiden Lane, N. Y.... 30	Ludwig, H. & Co., Providence..... 36	Watch Importers.
Riley, John A., 860 Broadway, New York... 25	Seamless Wire.	Wittnauer, A., 30 Maiden Lane, New York.... 6
White, W. E. & Co., 54 Page street, Providence, R. I..... 28	Burdon Seamless Filled Wire Co., 109 Sumner street, Providence, R. I..... 20	Watch Materials, &c.
Krementsz & Co., 182 Broadway New York... 25	Settings & Galleries.	Ceoss & Beguelin, 21 Maiden Lane, N. Y..... 29
Miller, James W., 37 Union Square, New York 24	Blancard & Co., 36 John street, New York.... 36	Keller, L. H. & Co., 64 Nassau street, New York 56
Moore & Horton, 11 Maiden Lane, New York. 51	Welded Steel.	Friedlander, R. & L., 65 Nassau street, N. Y.. 43
Owen, G. & S. & Co., 3 Maiden Lane, New York..... 45	Chrome Steel Works, Brooklyn, New York. 49	Watch Repairers.
	Simmonds, J. C., 18 John street, New York. 54	



CHAS. S. PLATT,

1837. Successor to George W. Platt, 1861.

GOLD AND SILVER

Refiner, Assayer and Sweep Smelter.

Office and Refinery,

29 & 31 GOLD ST., near John St., NEW YORK.

Platers' and Electro-Platers' Silver, Platinum and Aluminum.

Workshops to let, with power. Fine Light—speci- ally for Jewelers. All Improvements. Apply as above



S. P. HOWARD,

Gold and Silver Assayer,

Refiner and Sweep Smelter,

8 & 10 JOHN STREET, NEW YORK.

Smelting and Reining Works,

28, 30 & 32 Cumberland St., Brooklyn, N. Y.

Specialties: Sweepings, Gold, Silver and Platinum.

ESTABLISHED 1837.

TAYLOR & BROTHER,

Old House READ, TAYLOR & CO.,

IMPORTERS OF

Diamonds and Pearls

AND

Manufacturers of Diamond Jewelry,

860 BROADWAY, NEW YORK.

Branch Office, 1 1/2 Maiden Lane.

21 HOLBORN VIADUCT, LONDON.

206 KEARNY ST SAN FRANCISCO.

S. F. MYERS & CO., Wholesale Jewelers.

EVERYTHING

THAT

PERTAINS

TO THE

JEWELRY TRADE.

22

DEPARTMENTS.



WE REQUIRE

AND OCCUPY THE

LARGEST

SALESROOMS

IN OUR LINE.

4 STORES.

GROUND FLOOR.

48 & 50 Maiden Lane and 33 & 35 Liberty Street, New York.
CONSULT OUR MAMMOTH CATALOGUES.

L. LELONG & BRO.,

GOLD AND SILVER

Refiners, Assayers and Sweep Smelters,

◁ SOUTHWEST CORNER HALSEY AND MARSHALL STREETS, ▷

NEWARK, N. J.

SWEEPINGS A SPECIALTY.

THE ROGERS & HAMILTON CO.

WATERBURY, CONN.

— MANUFACTURERS OF —

Highest · Grade · Electro-Plated · Flat · Ware.

SEND FOR PRICE LIST.

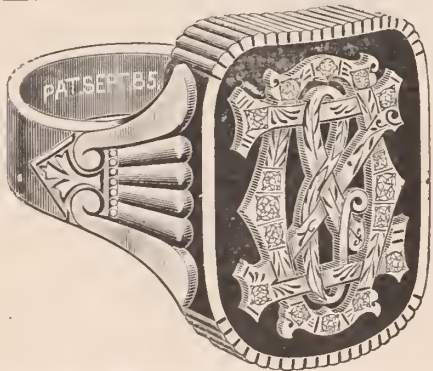

ODENHEIMER & ZIMMERN, ▷

MANUFACTURERS OF

Gold and Diamond

JEWELRY,



THE O. & Z.
Interchangeable Initial Rings, Locketts and
SLEEVE · BUTTONS,



Gents' Seal,

Ladies' Fancy and

Children's Rings.

46 Maiden Lane, New York.

ALBERT LORSCH & CO.,

37 Maiden Lane, New York.

P. O. BOX 2139.

167 Broad St. (P. C. Box 941), Providence, R. I.

IMPORTERS OF

DIAMONDS, PRECIOUS AND IMITATION STONES.

Sole owners and Importers of

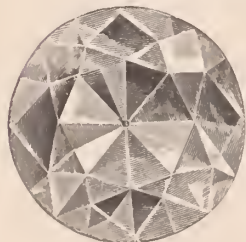

Unequaled in

The Sumatra Gem.
REG'D.

Brilliancy.

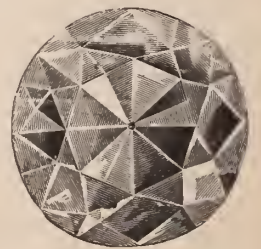

The nearest approach to the Genuine Diamond. For sale by all leading Manufacturers and Jobbers. * All Jewelry set with these Stones is sold on cards stamped "The Sumatra Gem, Reg'd."

L. & W. KAHN & CO., IMPORTERS OF DIAMONDS, 10 MAIDEN LANE, N. Y.

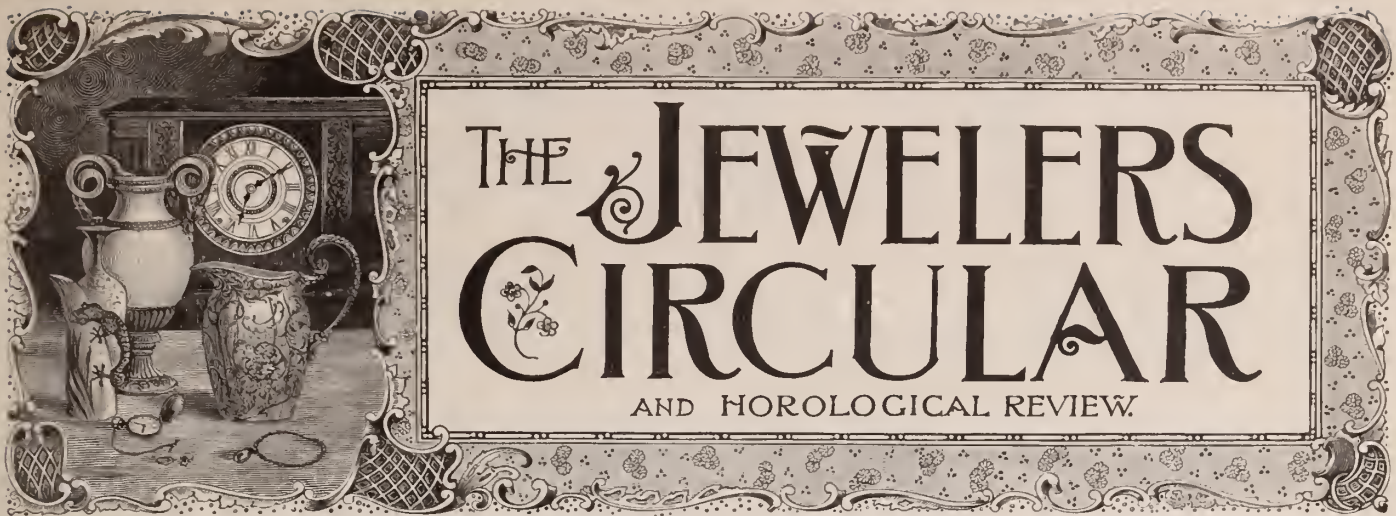

Entered at the Post Office in New York as second-class matter.

VOL. XXII.

NEW YORK, WEDNESDAY, FEBRUARY 18, 1891.

No. 3.

BRIEF HISTORY OF GOLD AND SILVERSMITHING.

Part II.

THE BYZANTINE PERIOD.

(Continued from page 24, February 11.)

IN those times silversmiths' work-shops were fitted and arranged in a way that would hardly suit the more refined artisans of the present day. Theophile, who was a silversmith and lived in the twelfth century, has written some interesting pages on that matter. The following information is borrowed from his book. A hole, three feet long and two feet wide was dug in front of the windows at about a foot and a half from the wall. Part of the hole was covered with a piece of wood for artisans to sit upon, and at the bottom of the pit smooth planks were arranged so as to form a floor wherefrom gold and silver filings might be easily gathered. A table, or bench, three feet long was fixed in the centre of the pit in front of the artisans and extending over their knees. This contrivance had been devised to allow the safe recovery of the falling particles of metal, and it answered the purpose very well.

The bellows of old had been slightly improved. The goat-skin, fixed between two planks, was moved by hand. The silversmith who made his own tools and imple-

ments, made also from beginning to end every one of the articles, plain or elaborate, which nowadays would have to pass through many different hands. These gold or silver workers understood chasing, repoussé, en-

style; and even cups, ewers and vases were adorned in obedience to the canons of ogival art.

Among the best specimens of that style, one of the most striking is evidently the cup shown in Fig. 10 which is reproduced from an old engraving of the unknown German designer who signed his designs W. A., and whose works are believed to have come out about 1480. Our illustration shows all the details so perfectly that we need not describe them.

SIXTEENTH CENTURY—RENAISSANCE.

With the sixteenth century gold and silversmithing are believed to have received new life. That period has always been considered one of the most brilliant, and the word master-piece is applied as a matter of course to all works which belong to the Renaissance. I must confess that I am not so enthusiastic about that style as most peo-

ple are, at least so far as Italian influence goes. Let it be understood that I limit my remarks to our branch of art, not having to consider here what are still termed "fine arts." I think



FIG. 15. DUTCH DRINKING HORN.

graving, enamelling, gilding, etc., and most of them were also designers.

Up to the end of the fifteenth century gold and silversmiths borrowed all their patterns and decorations from the ruling architectural

(Continued on page 45.)

F. & B.

LET THE FIGHT GO ON. The war between SEAMLESS and GOLD SOLDERED CHAINS will prove one of two things, either Seamless Wire is as good as Gold Soldered, or Gold Soldered is as good as Seamless.

A Dutchman offering a horse for sale was asked if the horse had the heaves. "I don't know," said the Dutchman, "but if de heaves are goot for de horse, de horse got 'em." If "Seamless" or "Gold Soldered" is good for chain, we've got 'em or can get 'em. We are making an honest, well finished chain of such good soldered wire that the seam cannot be found, and one that will wear ten years. The whole question is, who puts gold enough on their wire to make a good wearing chain? Some do and some do not. We make a finely finished chain of good, heavy, gold plated wire. Our chain will wear for ten years. We put our stamp on them which is a guarantee that the goods are right. The ten year chains.

Call for our Solderless Locket, made from stock that is as hard as it comes from the rolls, no solder used and the stock is hard and smooth.



THE WASHINGTON BRACELET.

Our "Washington Bracelet" is one of historic value. It shows a fine medallion of Washington, dates of his birth and death, dates of service as President, his seal, the original flag, his coat of arms and crest (from which was conceived our national flag), and the names of the thirteen original states.

We make a large line of Locketts and Charms, Chains in Vests, Dickens and Victorias, Neck Chains, Bar Pins, Jersey Pins, Stick Pins, Initial Scarf Pins, Initial Bangles, Chain Mountings, Bracelets, Garters, Interlocking Glove Buttoners, Bead Necklaces and Earrings.

FOSTER & BAILEY,

PROVIDENCE, R. I.

TRADE
SEAMLESS

MARK.

GOLD · FILLED · CHAINS.

ON ACCOUNT OF

THE great popularity of the chains made exclusively by us for the past three years, the air has been FILLED and the paper of the various Jewelers' Journals COVERED with the word "SEAMLESS" which has been and is our trade mark.

We never had such a boom in our business as we have had since our friends commenced to advertise our goods.

We have only a word to add, and that is we make and sell the

ORIGINAL AND GENUINE

SEAMLESS GOLD FILLED CHAINS.

In addition to the word SEAMLESS and for the protection of our customers we place upon each Chain a tag bearing the following trade-mark :



Which is affixed by authority of its owners, as a guarantee that the Chains are made from the Burdon Seamless Filled Wire.

BOSTON OFFICE,

6 WINTER STREET,

In charge of

I. W. STELLE.

NEW YORK OFFICE,

17 Maiden Lane.

PACIFIC COAST AGENCY,

WM. E. PETTES & CO.,

PHELAN BUILDING,

SAN FRANCISCO, CAL.

Address all communications to

KENT & STANLEY,

PROVIDENCE, R. I.

Comstock Raids a Watch Club.

ON the afternoon of Feb. 10, Anthony Comstock, accompanied by one of his agents, George E. Oran, Officer O'Connor, of the Tombs, and several officers of the Fourth Precinct, raided room 62 of the new Pulitzer building, the office of the Chicago Watch and Jewelry Co., and captured Charles A. Bailey, secretary, and John Tiedmann, bookkeeper, and seized eighteen gold filled case watches, six rings, a pair of ear-rings, a diamond stud and three scarf pins, besides the concern's account books, \$,000 circulars and 500 contracts. Bailey and Tiedmann were arraigned before Justice Hogan in the Tombs and held in \$1,000 bail each. The charge brought against them was conducting a lottery business. The examination was set for 2.30, Feb. 11, and were released on parole.

The letter head of the concern specifies offices in New York, Chicago, St. Louis, New Orleans, Kansas City, Milwaukee, Peoria, Houston, Galveston, Dallas and San Antonio, Tex., Buffalo, Wyandotte, Mich., St. Joseph, Indianapolis, Baltimore, Birmingham and Anniston, Ala., Shreveport, La., and Boston. O. C. St. Clair is president, and H. H. D. Klinker is manager.

Upon complaints concerning the enterprise received by the Society for the Prevention of Vice, Comstock commissioned Agent Oran to investigate the matter. The latter obtained one of the company's circulars in which their methods are described as follows:

Thirty-eight persons form a club and agree to pay \$1 per week, and a drawing for a watch is had on Saturday. One member draws his number, is given the watch and a receipt in full, and he drops out, his place being filled by another member to make the requisite thirty-eight. The circular states that if a member is so unfortunate as not to draw a watch in the thirty-seven drawings, he is given a watch upon receipt of the last payment. The advantages of this scheme are apparent. A member may get a 14-k. gold filled watch with good investment for one dollar and at the most it will not cost him more than thirty-eight dollars.

Agent Oran, under the name of Henry Williams, having paid his initial drawing fee on Feb. 3, he was entitled to thirty-seven drawings upon the payment of \$1 each time, and attended the drawing at 11 o'clock on Feb. 7. He found himself the only member present, but was shortly joined by another.

Thirty-eight envelopes containing slips were spread out on a desk. Secretary Bailey took several of them and threw them aside. Into about half a dozen of the envelopes he placed slips of paper on which numbers were written. He then shuffled the envelopes and asked the second member to draw. The number drawn was 2,428, belonging to Wm. J. Doyle, 53 Chambers street, who had been in the combination only eight weeks. To prove the existence of the lottery scheme, Agent Oran bought another ticket on February 10th. The arrest and seizure then followed.

After being released on parole, the defendants were re-arrested and arraigned before U. S. Commissioner John A. Shields, in the U. S. Circuit Court, on the charge of using the mails for the conduction of a lottery scheme. They were committed to Ludlow street jail in default of \$1,000 bail each, and the examination was set for 2 o'clock, February 18th. The usual amount of bail in such cases is \$2,500.

No examination took place at the Tombs on Feb. 11, as no bail had been furnished up to that time.

The Paillard Company Enjoined.

IN the Supreme Court Chambers, on February 11, Judge Andrews entered judgment for a permanent injunction to restrain the corporation that has been doing business under the name of the Paillard Non-Magnetic Watch Company, from the use of the name and trade-marks of the Non-Magnetic Watch Company, of America, and from the use of the name Paillard, and also entered judgment for an account of damages to the complainant company, including an account of the goods that the defendants have sold since their organization.

The action was instituted about eight months ago, and has been prolonged through the inability of the plaintiff's attorneys to serve summonses to the proper persons. C. P. Bruch, who was secretary and treasurer, was away from the city and suddenly resigned. Nathan Bushnell, although the certificate of incorporation shows his name as one of the directors, made affidavit, when served, that his name had been used without his knowledge. A. Hannaford was served, but made affidavit that he was only the bookkeeper. The question was referred to Emanuel Blumenstiehl as referee, who decided that the service upon

Hannaford was good, as he was the cashier, and no other responsible officer of the company was in the State. The judgment was thus granted through default in appearance of the defendants.

San Francisco.

Every other man you meet here, nowadays, has been, or is, or is about to become a member of a local watch club. The regular retail watch dealers are disgusted.

L. A. Berteling, of 427 Kearney street, has secured patents recently on instruments for measuring the strength of the eye and to determine the imperfections of sight.

Henry Nordman, of 120 Sutter street, will soon leave for New York and other Eastern points, in quest of new designs and spring goods for his extensive establishment.

Hammersmith & Vield, the Sutter street manufacturing jewelers, are turning out a unique line of fine leather goods with silver clasps. The firm recently issued a new catalogue.

The sale of the property of the Otay Watch Company took place on Monday, under a sheriff's execution. The property sold included watches, finished and unfinished, materials and tools. The proceeds of the sale were distributed among the employees of the defunct concern in lieu of money due them for wages.

George C. Shreve & Company, the leading silversmiths and manufacturing jewelers of the coast, will occupy store rooms in the new Crocker Building, now in course of erection at the junction of Market, Post, and Montgomery streets. The firm will have more commodious quarters, and the finest windows for display in San Francisco.

Society, as well as the trade, is interested in the police court trial of Ameliè Gehring, the maid of Mrs. Harry Gillig. Mrs. Gillig charged her maid with stealing her diamonds. It was developed at the time that the pretty maid gave away her mistress's jewels as Christmas presents. The court held the maid in \$2,000 bonds for trial. Mrs. Gillig brought Ameliè with her from Paris.

Apropos of the recent robbery of the diamond palace of A. Andrews, on Montgomery street, people are wondering why it is that such an air of secrecy concerning the affair is preserved, and while the police and detectives are continuing to impress the public



HOLLOW WARE.



ROGERS & BRO. A-1.

OLDEST BRAND AND HIGHEST GRADE OF

ELECTRO SILVER PLATE.

ROGERS & BROTHER, Manufacturers,

16 Cortlandt Street, New York.

Waterbury, Conn.

Photograph Albums and Price Lists upon Application accompanied by Business Card.

that all is mystery and doubt, the public is beginning to surmise either that there was no robbery at all, or that some one who had authorized access to the store stole the diamonds and bored the hole in the floor to divert suspicion from himself.

Detectives were in the city this week looking for E. B. Rogers, late manager of the Orleans Watch & Jewelry Company, who absconded recently, taking about \$10,000 in money with him. It is supposed he came to San Francisco, en route to Australia or China. Both ocean steamers leaving here this week were watched, but Rogers was not found.

Thomas Lorrigan and M. T. Dugan, clerks in the jewelry store of M. Cohen, on Sixth street, have been systematically robbing their employer. A few days ago Lorrigan left town, leaving Dugan to answer for the crimes of both. Dugan was promptly arrested on a charge of stealing, and also with receiving stolen goods.

Mystery is cleared away, however, by the following letter from Los Angeles :

The pocket-book containing \$12,000 worth of diamonds belonging to L. M. Wagner, of Los Angeles, which mysteriously disappeared two weeks ago, has been found. It was turned over to the Chief of Police by a Chinese vegetable peddler and by him returned to Wagner. The Chinese found the jewels the day after they disappeared in St. James Park. He did not know their value and exhibited them to various persons on his route. He sold one stone valued at \$600 to a servant

girl for \$5. Intelligence of this reached the police, and with the clue thus furnished, detectives were put to work. Finally the number of his vegetable wagon was found and by this he was traced, being finally run down yesterday afternoon. Wagner had for two weeks offered \$3,000 for the return of the jewels. The Chinese was given \$50.

Unearthed in a Farmer's House.

PETERSBOROUGH, Ont., Feb. 8.—The police were informed that a number of watches and chains answering the description of the jewelry stolen from Henry Patterson's store at Lakefield, had been seen in the possession of a farmer named Oliver Badgerow, who lived among the hills, six or seven miles back of Claremont. They drove to Badgerow's place. Badgerow's brother was there alone, and did not want to let his visitors in, but they forced him to open the doors. They asked for Badgerow, but the brother said he and his wife had gone to Toronto. The officers searched the house and came to one room that was locked. This they also forced the man in charge to open, and an astonishing sight met their gaze. The room was filled with a miscellaneous assortment of jewelry, watches, chains, pipes, combs, half a chest of tea, fancy goods, etc. The brother said he had bought them. However, the articles of jewelry which Williamson had seen and which were supposed to have been stolen from Mr. Patterson, were nowhere to be

found. The return of Badgerow from Toronto is now earnestly desired.

Syracuse, N. Y.

Hopper R. Nukins has an original window display consisting of a charming arrangement of jewels, mounted and unmounted. The mounting is all done in his establishment.

Whether a well-managed manufactory is a benefit to a village, has been admirably illustrated at Lyons, N. Y. The newly-established silver-plating company disbursed \$30,000 in wages during 1890, paid a dividend of 7½ per cent. and used 7½ per cent. more of net earnings to enlarge the business.

J. Frank Davis, of D. M. Osborn & Co., of Auburn, N. Y., has been appointed manager of the Chicago branch of that concern. Just before he departed to assume his new position he was presented with a handsome solitaire ring, on behalf of the foremen and employees of all the shops. The presentation was made by Clarence F. Baldwin. The ring was got up by jeweler Crossman.

E. B. McClelland, of Syracuse, N. Y., exhibits a striking novelty in a birthday case of rings. It is a collection of twelve rings, one for each month in the year, and each set with the jewel appropriate to the month. The case is lined with white satin and contains a separate apartment for each ring. On the white satin lining of the cover is printed a sentimental legend pertaining to the jewel of each month. The case is made of Russia leather.

THE PAIRPOINT MFG. CO.
New Bedford, Mass.

FINE
* GOLD *
AND
SILVER

Plated Ware.



OUR LARGE LINE
OF
STAPLES
AND
NOVELTIES

WILL BEAR INSPECTION.

Quality
Guaranteed.

NEW YORK.

No. 110. COFFEE SET.
CHICAGO.

SAN FRANCISCO.

New York Notes.

There is a likelihood of Fellows & Co. going out of business May 1.

M. Schiff & Son, 1193 Third avenue, were last week sold out at auction.

Franz Wacker has sold out his store at 178 Bowery and is out of business.

The Roy Watch Case Co. has leased the entire first floor of 17 Maiden Lane, which on May 1 will be rearranged in handsome style.

Mr. Draper, the New York representative of Ripley-Howard Mfg. Co., Boston, whose office is at 17 Maiden Lane, is looking out for new quarters.

On May 1, the building at 19 Maiden Lane will begin to be completely overhauled. It will be furnished with elevators, and will have a front entrance.

On May 1, Jos. Fahys & Co. will move from 38 to 41 Maiden Lane, in the store now occupied by the Maiden Lane Buffet. The new office will be twice as large as the present one.

The Metropolitan Watch Co. has secured a judgment against T. B. Gross for \$182.

A judgment for \$17.94 in favor of H. F. Frasse and others was last week recorded against Henry Lorient.

The firm of Webster & White, 30 East Fourteenth street, has been dissolved, Robt. W. White, Jr., retiring. The business is continued by and under the name of A. A.

Webster, who is a member of the firm of A. A. Webster & Co., Brooklyn.

Charles J. Knothe, indicted on two charges of grand larceny in the first degree of diamonds and jewelry valued at \$2,450 from H. C. Hardy & Co. and Randel, Baremore & Billings, on February 12 pleaded guilty and was sentenced by Judge Cowing, to five years in the Elmira Reformatory.

Dave Cummings, known to fame as "Little Dave" or "Baltimore Pat," who has for many years made a specialty of robbing jewelry stores, on February 12 pleaded guilty in the General Sessions of having burglar's tools in his possession with intent to use them, and was sentenced to States prison for five years by Judge Cowing.

William A. Keddie, for eighteen years with Henderson & Winter, has formed a partnership with John E. Shepard, one of the oldest jewelers on the Lane, under the name of John E. Shepard & Co. The new firm will conduct a retail business and a wholesale business in marble clocks. The place of business is 1½ Maiden Lane.

Henry Purcell, the nineteen-year old youth who two weeks ago robbed Reed & Barton of spoons valued at \$40 and Tiffany & Co. of silverware valued at \$20, as reported in the last issue of THE CIRCULAR, was on February 9 sentenced on the charge of grand larceny in the second degree to two to five years in the Elmira Reformatory, by Judge Cowing.

On May 1st the S. Cottle Co. will move to the beautiful Jackson Building now being erected on Union Square, adjoining the building they are in at present. They will occupy the entire first floor 28 x 184 feet extending from 17th street to 18th will undoubtedly have one of the finest factories in the city. There will be perfect light all around the floor, from which can be seen a panorama of the suburbs. The factory will have a double flooring with roof paper between which will prove a profitable feature to the business in saving gold.

On the evening of February 13, George F. Kunz, the well-known gem expert, lectured at the Franklin Institute, Philadelphia, his subject being "The Occurrence of Gems and Precious Stones in North America." The lecture consisted of a condensation of the lectures "Gems and Precious Stones of North America," together with descriptions of the discoveries made during the past year. Mr. Kunz illustrated his lecture with fine stereopticon views from photographs, which he had personally taken, of gem deposits throughout the United States and Mexico, including the opal mines of Mexico, the turquoise mines of New Mexico, the sapphire deposits of Montana, and the golden beryl deposits in Connecticut. A second edition of "Gems and Precious Stones of North America," which will be issued in about a month, will contain accounts of new deposits which Mr. Kunz described in his lecture.

(Continued on page 26.)

The R. Wallace & Sons Mfg. Co.,



No. 230 CUP. IN STERLING SILVER, TWO-THIRDS SIZE.

MANUFACTURERS OF

Sterling Silver, Plated Ware & Fine Cutlery

FACTORIES, WALLINGFORD, CONN.

New York Store: 3 Park Place.
Chicago Store: 104 State Street.

A. WITTNAUER,

Successor to J. EUGENE ROBERT & CO.,

No. 30 MAIDEN LANE, NEW YORK,

MANUFACTURER AND IMPORTER OF

WATCHES AND WATCH MOVEMENTS.

AGASSIZ

AND

LONGINES

MOVEMENTS,

FITTING

6, 16, 18 Size Cases, in 3 Grades.

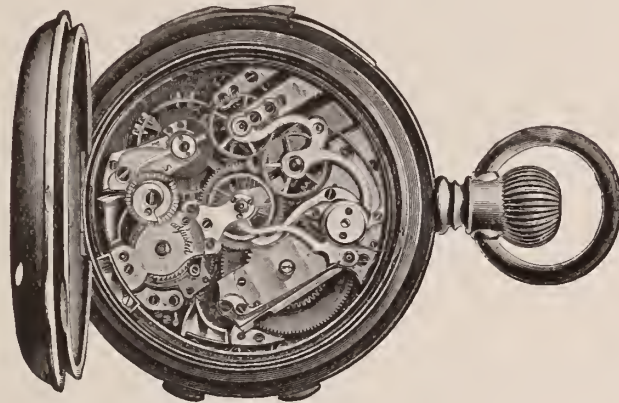

SOLE AGENTS FOR

LOUIS AUDEMARS

AND

JULES MONARD,

GENEVA

Unexcelled Timekeepers.

CHRONOGRAPHS, SPLIT SECONDS, MINUTE REPEATERS, &c.

16 and 18 Size Movements, Open Face and Hunting. Thoroughly Adjusted for Accurate Time and Railroad Use.

LEWIS BROTHERS,
Easter Novelties in Silver,
41 Maiden Lane, N. Y.

A. J. GROENMAN & CO.,
DIAMOND CUTTERS,
80 Nassau Street,
NEW YORK.
SMALL MELEE A SPECIALTY.

MAXHEIMER & BERESFORD,
MANUFACTURERS OF
FINE DIAMOND JEWELRY,
No. 3 Maiden Lane, New York.
ORDER WORK A SPECIALTY.

A. RICKERT. C.A. STIEHLE.
RICKERT & STIEHLE,
MANUFACTURERS OF
GOLD CHAINS,
SWIVELS AND SPRING RINGS.
Chain Repairing a Specialty.
13 & 15 Franklin Street, NEWARK, N. J.

N. SCHWARZ,
MANUFACTURER OF
VELVET AND LEATHER CASES,
866 Broadway, New York.

The "BRYANT" Initial Ring.

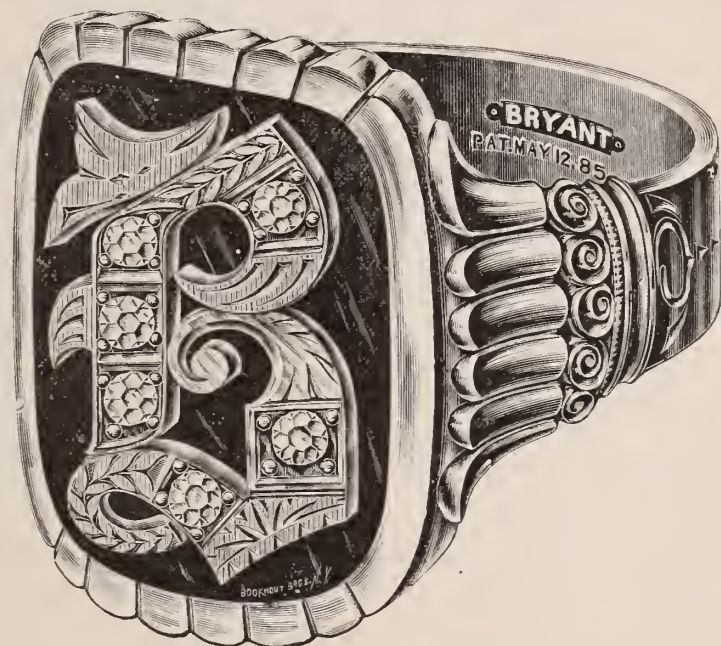

In Various Styles, Most Easily Interchangeable,
Handsome and Best.

M. B. BRYANT & CO.,
10 MAIDEN LANE, - - - NEW YORK.



Easy Lessons for Opticians.

BY DR. C. A. DICKLIN, A.M., M.D.

WE will now consider the methods used in detecting, excluding and locating visual obscurities. Visual obscurities are a constant source of annoyance to opticians in their daily work. When complicating errors of refraction, the patients are unable to answer intelligently regarding the amount of improvement which any experimental glass produces, because of the great reduction in the acuteness of vision. It is, therefore, of great advantage to discover their existence as early as possible, and thus avoid unnecessary and useless trial tests with the lenses. Having discovered that visual obscurities exist, satisfactory improvement of vision by proper lenses must not be looked for, as the desired result is a physical impossibility.

Visual obscurities exist in the cornea, the lens and the vitreous humor. By far the most frequent location of visual obscurities are in the cornea. A granular eyelid or ingrowing eye lashes, which scratch the cornea, are the most frequent causes of these obscurities.

Obscurities in or on the lens are all classed under the general name, cataract, and will be considered in full under this heading. Opacities in the vitreous humor are seen by the patient as smoke, dark clouds and floating specks. The methods used for detecting and locating visual obscurities are three in number.

The first and best general test for obscurities of vision is the retinal reflex. This method is particularly adapted for discovering obscurities located in the lens or vitreous humor.

The second method is the oblique illumination. This is the only method by which very diffuse obscurities of the cornea can be discovered. This method is used almost exclusively for examining the cornea, but may also be used to examine the anterior surface of the iris and lens.

The third method is called "The Catoptric Test." This method is very old and was in use for centuries before the ophthalmoscope was thought of. It is of the least advantage of any of the three methods in discovering the existence of a visual obscurity, but it enables one to decide positively whether an obscurity seen in the eye is located in the lens or behind it. Our ability to locate a visual obscurity is sometimes of incalculable value.

These various methods of detecting obscurities are very easily practiced. They can be learned by an inexperienced person after a few trials. All three of the methods can be executed within three minutes on any eye,

and will give decisive answers as to the clearness of the media through which the light must pass to reach the retina. Every one attempting to adjust lenses for imperfect vision is in a very awkward position, unless he is familiar with the methods of detecting visual obscurities. He never can be certain whether a failure to produce satisfactory vision is due to his mistakes, or to the imperfections in the individual's eyes.

Retinal reflex is usually practiced in the following manner: In a darkened room a light is placed slightly behind and to the side of the patient whose eyes are to be examined. At some ten inches from the eye the light is received on the mirror of an ophthalmoscope or on a plane mirror from which around piece of the silvering about one-eighth of an inch in diameter has been removed.

The light is now reflected into the eye better in a slightly oblique line, for the purpose of avoiding any confusing light from corneal reflexes. If there are no visual obscurities present with the examiner's eye placed to the hole in the mirror, a *bright clear red* reflex will be seen resulting from the light returned from the retina by reflection.

Should visual obscurities be present, they will appear as dark, or gray spots on a bright red background. They are so distinct when located in the lens or vitreous humor, that the most careless observer cannot fail to see them. A diffuse obscurity of the cornea however can be entirely overlooked by this method. We cannot be certain from this alone that visual obscurity is not accountable for the unsatisfactory vision existing until we have also made use of oblique illumination. Having practiced these two methods of visual obscurities, we presume they must be discovered.

Oblique illumination is practiced in the following manner: In a darkened room a light is so placed within one foot of the eye that with a convex lens No. 2½, the light can be concentrated on the cornea from the temporal side of the eye examined at about an angle of forty-five degrees to its optical axis. If the examiner has very sharp eyes, any diffuse obscurity on the cornea will at once appear as a milky cloud.

The vision of the examiner's eye can be reinforced by the use of a second convex lens No. 2½, held in the other hand while the cornea is illuminated. This will show any defect of the cornea strongly magnified.

This method for the examination of the condition of cornea is extremely satisfactory even in the hands of the entirely inexperienced. It occasionally happens that an obscurity is discovered deep in the eye; in which case it is extremely important to decide whether the obscurity is an inflammatory product, or a tumor in the vitreous chamber; or whether it may be simply an obscurity located deep in the lens. Cases arise where without the "Catoptric Test" it would be impossible to decide positively whether it was in the lens or behind the lens. In the former case it is simply cataract and can be treated at such time and in such a manner as appears best. When it is behind the lens in young children the presence of a peculiar

form of cancerous growth, called glioma, is strongly probable. This makes the immediate removal of the eye imperative. The Catoptric Test is practiced in the following way. Light from a candle is allowed to fall obliquely on a moderately dilated pupil. At once the light reflex from the cornea will be seen and also a bright sharp reflex will be seen from the posterior capsule of the lens. The reflex from the anterior capsule is rather difficult to see but may be easily discovered with a little practice. But as it is of no possible use in this experiment it may be entirely ignored. The reflex from the posterior capsule of the lens is the all-important one—it is bright and can be easily seen.

The light is so moved that this little reflex falls exactly on that part of the pupil where we have located an obscurity by the retinal reflex. If the obscurity is in the lens, the light reflex is immediately lost. If the obscurity is behind the lens, the light reflex remains where it falls on the place where the obscurity is known to be. It will be seen that this method gives a very positive answer to the question "Is the obscurity in or behind the lens?" It is most necessary for those interested in optics who wish to understand the above described methods, to practice them on an eye with the above text before them. One drop of a four per cent. solution of cocaine in the eye of any member of the family will produce in ten minutes a largely dilated pupil, which will in no way annoy the one experimented on, and which will give a most satisfactory opportunity to demonstrate the methods used in detecting and locating the position of visual obscurities. The solution of cocaine may be obtained from any physician. Persons having naturally large pupils, which is very frequently the case with myopic persons, will not require cocaine in the eye to render them satisfactory subjects upon which to practice these methods.

We will take up in our next the systematic consideration of the nature of visual obscurities.

Elmira.

The friendship ring craze, which was a profitable one for the trade, has given way to a demand for silver necklaces and silver hearts. They are very simple and pretty for evening wear.

A. Landy makes a specialty of buying old gold and silver, and annually sends a large amount of the silver to the mint, where he secures the earliest issue of pieces for the following year. He had 1,000 silver dollars stamped 1891, early last month, and makes a good advertisement by trading them for older money.

At the Pistol's Point.

CLEVELAND, O., Feb. 7.—Two men entered the jewelry store of E. L. Wilsdorf last evening when everyone but the young clerk had gone to supper. With pistols pointed at him they stole twenty-one gold watches and locking the front door after them, escaped. The watches were worth \$1,000.

Theoretical and Practical Study of Depthing with Pinions of Low Number.

By J. Rambal, Watchmaker, etc., and Principal of the Horological School at Geneva, Switzerland.

ASIDE from a few additions the following is the text of two lectures delivered before the Horological Institute of Geneva :

It is not claimed that the important subject of depthing has been treated in all its bearings in regard to watchmaking. The limits of time have caused me to confine myself to the consideration of epicycloidal teeth of wheels driving pinions of low number ; *i. e.*, pinions of less than ten leaves. I have en-

perimental demonstrations by means of such apparatus as would best convey the idea of the formation of epicycloidal curves. It is intended that the workman shall reproduce such by means of simple devices that I will suggest and explain, and which are neither more or less than a few discs made of paste-board. Such discs are intended to revolve inside and outside a round paste-board box-cover fixed on a sheet of paper. Better apparatus will of course, be needed for obtaining results of precision ; but for the purpose of acquiring a knowledge of the subject those suggested will be all that are needed.

THEORETICAL PART.

We seldom find in very old watches any other than pinions having six, and some not having more than five leaves ; which fact ought not to astonish us, as the difficulty of making pinions at the time when such watches were made must have been great. Later on, the means of manufacture were better developed ; the wheel cutting machine was invented, and the greater precision which could be reached with such a tool naturally caused a gradual increase in the number of the teeth of the wheels and the leaves of the pinions. These latter first increased to eight, and then to ten leaves ; and at the present time in some of the best productions of watches, pinions of twelve, fourteen and even sixteen leaves are used. It must not, however, be assumed that pinions of low numbers have been definitely abandoned. Such an occurrence would, indeed, be desira-

ble, and from all appearance this seems to be the general tendency ; but for obvious reasons they will never be entirely abandoned ; for in very small watches, pinions of six, seven and eight leaves are the only ones that

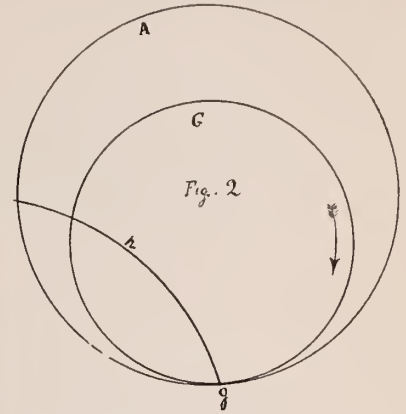
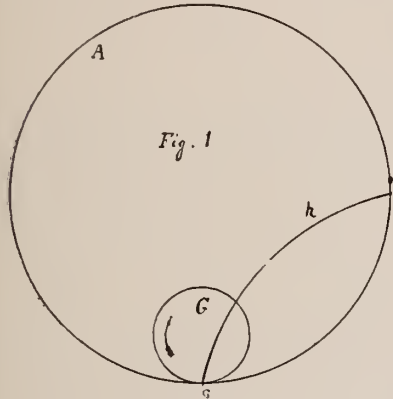

deavored to present the subject in such a manner as to render it intelligible to workmen not conversant with geometry ; and with this view I have had recourse to several ex-

can practically be employed. The same may be said in regard to certain portions of the train of larger watches. It is necessary, therefore, to direct our efforts to the making of such pinions in the best manner or rather in the least objectionable manner—for their inherent defects are those with which the watchmaker is obliged to deal. For this reason many manufacturers have their own system in arranging these depthings, and a few words in explanation may not be out of place.

1. To begin with, an analysis of the general principles of a pitching may be in

IMPORTANT NOTICE.

The New Trenton Movement.
H.T.G and O. F. S. W.



(OPEN PLATE.)

No. 40, Nickel, - - - \$4.00
No. 41, Gilt, - - - 4.00



(CLOSED PLATE.)

No. 60, Nickel, - - - \$3.75
No. 61, Gilt, - - - 3.75
LESS CASH DISCOUNT.

We beg to notify the trade that we have placed on the market a **NEW MODEL**

18-Size, Seven Jeweled, S. W. Nickel Movement,

SURPASSING ANYTHING YET MADE FOR THE PRICE, and to which we invite your attention. These movements possess several new features which offer special advantages to watchmakers. They are Quick Train, Straight Line Lever Escapement, and have Safety Centre Pinions and hard enamel Dials. The barrel can be removed without disturbing the train or stem-winding parts. They are beautifully damaskeened, well finished and attractive in appearance and are **EXCELLENT TIMEKEEPERS. EVERY MOVEMENT FULLY WARRANTED.**

The Best Low Priced Movement in the Market.

FOR SALE BY THE JOBBING TRADE.

Send to your jobber for a sample movement. If he does not keep them, write us and we will furnish you the names of jobbers who do.

TRENTON WATCH CO., Trenton, N. J.

order. And to confine ourselves to our text let us consider by way of example, the depth- ing of a wheel of sixty teeth, and a pinion of six leaves.

2. The distance which separates the pivot- holes is called the distance of centres. It comprises the radius of the wheel and that of the pinion. These two radii encroach on each to a certain extent, which we call the penetration of pitching or depthing.

Let us suppose that we cut from the teeth of the wheel all the acting part or curves. Let us suppose, likewise, that we cut from the pinion all the rounding of the leaves. By

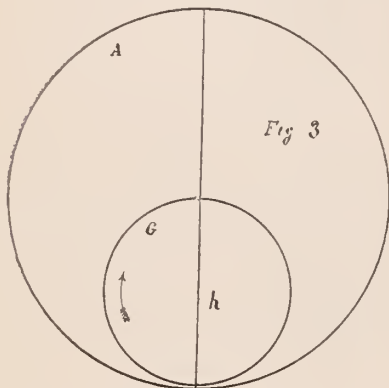

these operations the radius of each mobile will be reduced to what is called its primitive dimension, and we will have obtained the primitive radii of the wheel and pinion. The circles corresponding to these radii will then be the primitive circles of the two

mobiles. These two circles placed in contact will give exactly their centre distance.

3. In the construction of gearings the consideration of the primitive circle of each one of the two mobiles is of the utmost importance, as they form the basis of their correct completion. The sizes of the two primitive circles, or their diameters, must be to each other as the number of teeth of the one—the wheel—is to the number of the leaves of the other—the pinion.

Thus, with a wheel having sixty teeth and a corresponding pinion having six teeth, the primitive radius of the wheel must contain the primitive radius of the pinion ten times. The circle of the pinion will then be divided into six parts, and that of the wheel into sixty parts. The space of one of these parts constitutes the pitch of the depthing. (Fig. 6.)

4. Let us see now, what shape we must give to the teeth of the wheel and to the leaves of the pinion in order to realize the most essential condition of gearing; viz.: the uniform propulsion of the pinion by the wheel.

This condition of uniformity of propulsion would be fulfilled if each of the mobiles were reduced to its primitive circle, these two circles moving each other by a pressing contact without slipping, like the rolls of a rolling mill. The consideration of such a condition will be the point of departure for the construction of the teeth of the mobiles.

5. We will now consider the curves of the gearing. Let us suppose a circle, *g*, Fig. 4, tangent to another circle, *b*. If we roll the first upon the second and mark a point, *g*,

tangent to the two as a starting point we describe with this point a curve, *e*, which we call an epicycloid. Figure 4 shows the epicycloidal curve, *e*, described by the point, *g*, after a third of a turn of the circle, *g*.

This last is called the generating circle and the point, *g*, the generating point of the curve.

If, instead of having one of the circles turn-

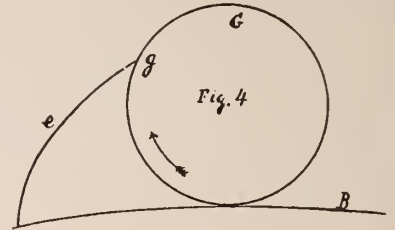

ing around on the outside of the other, we place it inside of Fig. 1, an analogous condition will be produced. In causing the circle, *g*, to rotate in the direction of the arrow along the inside of the circle, *a*, the point, *g*, will describe the curve, *h*, called a hypocloid.

If the circle, *g*, is larger in diameter than one-half of the circle, *a*, the curve will tend in the opposite direction (Fig. 2).

The curves of figures 1 and 2 are found to be symmetrical, because the generating circles are respectively one-fourth and three-fourths of the circle, *a*.

If in choosing the dimension of circle, *g*, we make it of a diameter equal to the radius of the circle, *a*, the line, *h*, will then take the form of a straight line.

H. A. WADSWORTH & CO.

MANUFACTURERS OF

GOLD · FILLED · WATCH · CASES,

NEWPORT, KY.



WHEN ANSWERING ADVERTISEMENTS PLEASE MENTION THE JEWELERS' CIRCULAR.

We will now be able to fully understand the simultaneous tracing of the curve of the tooth of the wheel and the flank or side of the leaf of the pinion.

6. Figure 5 shows us the primitive circle *a* of the pinion, tangent to the circle *b* as it ought to be.

If we place the generating circle *g*, which is one-half of the diameter of *a*, in such a

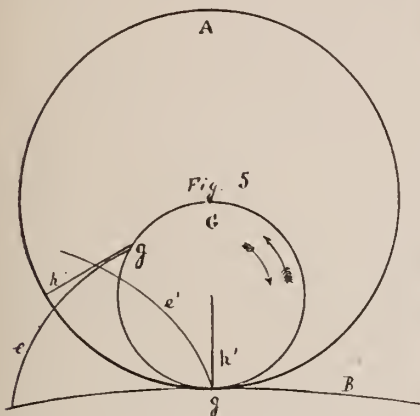

manner that the three circles are tangent at a single point; and roll the two smaller ones on the larger one from left to right, maintaining their tangent condition during the operation, we will see that the generating circle, *g*, will have described at the same time, first, an epicycloid, *e*, around the circle *b*; and second, a hypocycloid, *h*, inside the circle *a*.

By rolling the circles from right to left we will determine the tracing of the lines *e'* and *h'*.

It is clear that in taking for the flanks of the leaves of the pinion the lines *h* and *h'*,

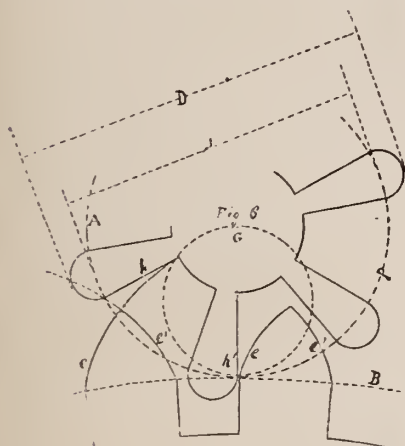

and for the curves of the teeth of the wheel the lines *e* and *e'*, the teeth so formed will drive the pinion uniformly, since the flank of the pinion leaf and the curve of the tooth of the wheel have been generated simultaneously by the same generating point.

(To be continued.)

BUTTE, Mont.
Cannot keep house without it.
J. H. LEYSON.

ESTABLISHED 50 YEARS.

RANDEL, BAREMORE & BILLINGS,

IMPORTERS OF

DIAMONDS,

AND OTHER PRECIOUS STONES.

FINE PEARLS A SPECIALTY.

MANUFACTURERS OF

DIAMOND JEWELRY,

IN THE LATEST DESIGNS.

Diamonds Recut in Modern Styles or Repaired on Premises.

58 Nassau Street,
29 Maiden Lane,
NEW YORK.

1 Tulp Straat,
AMSTERDAM.

1 St. Andrews St.,
Holborn Circus,
LONDON, E. C.

LARTER, ELCOX & CO.

MANUFACTURERS OF

SNAKE RINGS, White Onyx Link Buttons,

LADIES', GENTLEMEN'S AND CHILDREN'S RINGS.

ALSO NEW PATTERNS IN

THE PATENT SPRING BACK STUDS.

FACTORY, NEWARK, N. J. + + OFFICE, 41 & 43 MAIDEN LANE, N. Y.

OPPENHEIMER BROS. & VEITH,

Diamonds, Watches and Jewelry,

2 Tulp Straat,

AMSTERDAM.

35 Maiden Lane,

NEW YORK.

We beg to inform the trade that we are still in a position to fill orders for

DUEBER HAMPDEN WATCHES

Of all grades, from stock purchased previous to the closing of the factories at Canton.

SWARTCHILD & CO.,



Our Complete Catalogue, illustrated, will be sent to any one forwarding us their address, free of charge.

We give special attention to mail orders. They are filled promptly the same day that they are received.

76 and 78 State Street, Chicago.

Paris News

PARIS, February 9, 1891.

RIVAL jewelers in the Rue de la Paix are endeavoring to give to their displays an individual appearance. They manage it, not only by devising a special arrangement, or in selecting original patterns, but also by each jeweler adopting a different gem for display purposes. The result is that when you leave one shop and enter the one next door, it almost seems as though you had passed from one country to another. Debut, Melleris, Dumoret, Aucoc, Ravaut, Vever, have all something especially attractive to show you; and idlers of taste who spend an afternoon in passing a successive review of all these places are often at a loss to name the shop that won their preference.

In one of these shops I noticed a whole set, necklace, bracelet, brooch and ear-rings, of a pattern imitating chain-work. All the links, which are of a lozenge shape, are formed of gathered diamonds and divided by a turquoise. The greenish-blue gem, the favorite stone of this place, shows in large size as the pendant of the necklace. It hangs, also, finely set, from a short, double chain, fixed to the bracelet. It reigns in the center of the brooch, framed with small diamond links and prettily dangles, drop-shaped, from a fine diamond bead-work.

In a neighboring display pearls are prominent. There I see a whole row of ear-rings consisting simply of a large pearl (white, gray, black or pink) with a tiny brilliant sparkling on the back of the hook. Shoulder pieces and corsage garnitures, with diamond embroidery on a gold net-work background, exhibit here and there fine sized pearls, etc.

Hair pins and combs admit of unlimited fancy. The tops are generally of open-worked gold. I noticed one in the shape of a loom with a gold bamboo frame, a spray of dog-roses in vari-colored stones showing on the snowy silver web; another one is like a crosier's head, in massive chased gold studded with rubies, sapphires and diamonds, with chimera, fiercely grasping it crossways.

Among the novelties in the silver line that are being made in aristocratic workshops I noticed a coffee set with a relief decoration oxidized, gilt and encrusted with gems. The outside of the pieces thus adorned, closely resembles stamped and worked leather, as exhibited in the binding of rare books. The inside is finished off in pale gold. The embossed part is obtained in repoussé on sheets of silver, which are subsequently applied on a plain piece. In the centre of the tray there is a bumping escutcheon of cartouche of oval shape, surrounded with floral ornaments which extend all over the surface. The stalks come out in yellow gold, and the flowers consist of encrusted pearls and rubies, the back-ground being of a stuffy, oxidized brown. A three-letter monogram, boldly



RYDER & DEARTH, DESIGNERS & ENGRAVERS

Fine Commercial and Copper-Plate Printers.

A Specialty of Jewelers' Printing, Cuts and Electrotypes. Headquarters for JEWELERS' CARDS.

BEST WORK. PROMPT DELIVERY. LOW PRICES.
No Order Too Large! None Too Small!
146 Westminster Street,
PROVIDENCE, - RHODE ISLAND.



OSTBY & BARTON,

**SOLID GOLD BAND, STONE
- - AND FANCY RINGS - -**



→ — ALSO A LARGE LINE OF EMBLEM RINGS. — ←

designed, is formed of brilliants, topazes and rubies, one kind of stones for each letter. The gourd-shaped hollow pieces of the set are decorated in the same way. The handles are formed of entwined dragon-headed snakes, with rubies for the eyes, the body being covered with crossed-lines to imitate the serpent's skin, and finished off in changing green gold with a sprinkling of tiny brilliants.

A rock-crystal reliquary with gilt silver mounting, exhibiting scenes in enamel, has just been added to the Louvre's collections. This reliquary, which is an early work of the fifteenth century, once contained one of the arms of St. Louis, Bishop of Toulouse and grand-nephew of Louis IX. of France. It is a gift from Madam Spitzer.

The Baroness Double noticed, the other day, that one of the rarest items of her remarkable collection had disappeared. It is a Louis XVI. bonbon box in gold and green enamel, with a medallion in the centre, which contains a painted scene introducing graceful figures assembled to celebrate the fête of Spring. That handsome box had been made to order by Mathys de Beaulieu, for Marie Antoinette. JASEUR.

To Restrain Newwitter.

JUDGE ANDREWS, in the Supreme Court Chambers last week, granted an injunction to restrain Nathan J. Newwitter, assignee of D. H. Wickham & Co., from disposing of a note which the defunct firm held against Henry Fera, No. 10 Maiden Lane, for \$536.25. At the time of D. H. Wickham & Co.'s failure in the latter part of October last, that firm was debtor to Henry Fera in the sum of \$1,390.60, the face value of a bill of exchange which had been accepted, and which fell due a few days after the assignment. Wickham & Co. on October 9 gave Mr. Fera a note for \$536.25, which will become due June 9 of this year. The attorneys of Mr. Fera desired the assignee to effect their client's credit with this note. This, however, the assignee refused to do, on the ground that Mr. Fera's note was not due at the time of the assignment. They thereupon, on February 2, instituted an action and applied for an injunction.

Received Stolen Goods.

LAFAYETTE, La., Feb. 6.—Sheriff Broussard to-day arrested one A. Schwab, the man who keeps a jewelry store next to Mouton's saloon, on a charge of receiving stolen property. The goods were reported as having been stolen from Barney Fagan of New Orleans. The thief, it appears, sold the watch and chain to Mr. Schwab for \$11. On receiving this information Sheriff Broussard procured the necessary papers and searched his establishment for the stolen property. But failing to find it he had Mr. Schwab arrested for receiving stolen goods. Schwab was taken before Justice Greig and remanded in default of bail. The officers are using every effort to recover the jewelry, and something new is promised before the case is ended.

USE THE 
AMERICAN MAINSPRINGS
 FOR ALL KINDS OF AMERICAN WATCHES.
 [FACSIMILE OF WRAPPER.]

1 DOZ. MAINSPRINGS
 18 S. E. O. S. 
 Extra Quality.
 TRADE  MARK.

THE BEST IN THE MARKET.

L. H. KELLER & CO.,

Dealers in Fine Watch Materials and Tools.

Agents for the Patek, Philippe & Co. Watches.

64 NASSAU STREET, NEW YORK.

SEXTON BROS. & WASHBURN,

41 MAIDEN LANE, NEW YORK,

MANUFACTURERS OF

FINE JEWELRY,

INCLUDING A FULL LINE OF MOUNTINGS.



PROMPT AND CAREFUL ATTENTION GIVEN TO SPECIAL ORDER WORK.

THE WALTHAM SCHOOL OF HOROLOGY,

D. D. PALMER, Teacher and Proprietor.

Best Advantages in the Country for Horological Instruction.

All branches under the personal supervision of D. D. PALMER, for a number of years in charge of the Adjusting Department of the Waltham Watch Co. POSITIONS GUARANTEED TO APT PUPILS. For terms and other particulars, address

D. D. PALMER,
WALTHAM, MASS.

Specialty of Difficult Repair Jobs.

H. H. HEINRICH,

12, 14 & 16 John St., New York.

Manufacturer of

MARINE CHRONOMETERS.

Silver Medal, Paris Exhibition, 1889.

A large stock of new and second-hand Marine Chronometers on hand. All my second-hand Chronometers are thoroughly overhauled, refinished and re-adjusted. Rented out at \$5.00 per month, payable in advance. No rent charged if bought within a certain time. Terms to suit customers. Marine Chronometers repaired and adjusted for the trade.



KENDRICK & DAVIS,

LEBANON, N. H.

MANUFACTURERS OF THE

Standard Dust Proof Watch Key.



After this date all Keys of this Style will have number stamped on each Key.

 FOR SALE BY THE TRADE.

The Synthesis of The Ruby.

EXPERIMENTS OF E. FREMY AND A. VERNEUIL.

THREE years ago, says *La Nature*, we laid before our readers the first result of Messrs. Fremy and Verneuil's experiments on the artificial production of the ruby and reproduced the crystals of rubies obtained by



FIG. 1.

these scientist—chemists at that time. The eminent director of Museum, Mr. Fremy, has, together with his collaborator, continued his researches and both have succeeded in producing, by synthesis, much larger crystals than in their first essays. These new rubies may be cut, and there is every prospect that they will be employed in horology. We publish in its entirety the note which Mr. Fremy has presented to the Academy of Sciences, at its sitting, November 10, 1890:

"The Memoire which I present to-day with the co-operation of Mr. Verneuil, is for the purpose of acquainting you with the modifications which we have introduced into the synthetical production of rhombohedral rubies. The crystals obtained by us indicate an advancement in our researches. Our aim was to obtain large crystals of rubies by producing them in the *dry way* as other crystals are produced in the *wet way*, and we believe to have solved the problem. Since our last publication we have made important alterations in our experiments. In place of employing absolutely pure alumina we at present use it as rendered alkaline with carbonate of potash; this addition of alkali in no manner alters the purity of the crystal, as we have established by numerous analyses. The potash facilitates the regular formation of the crystals, gives them a nice color and does not incorporate with the rubies.

"In our first essays we attached great importance to the mixing of the substance intended for the formation of the rubies, while at present we find it advantageous to separate the alumina located with chrome and potash from the alkalino-terrous fluor. The reactions which produce the rubies take place in this manner between the vapors and gases,

which is the condition of formation of hard and rhombohedral rubies. In our previous experiments the duration of our calcinations rarely extended beyond twenty-four hours, while at present it lasts an entire week; and we would desire even that it could be prolonged to several months—the duration of calcination exerting a great influence upon the size of the crystals.

"Important alterations have been effected both in our fuel and the nature of our furnaces, the coke furnaces employed in our former experiments has been entirely abandoned and replaced by the gas furnace, which produced a constant and very high temperature. The crucibles are no longer attacked by the cinders of the fuel, and those which we now exhibit to the Academy have sustained a degree of 1300 and have not become deformed.

"Of all the improvements introduced in our operations the most useful is the enlargement of our crucibles. Our experiments were formerly made with small laboratory crucibles which produced only a few grams of rubies. We replaced them by larger ones of several liters capacity, whereby we often obtain more than 3 kilograms, 6 lbs. 10 oz. a voidupois, rubies at each operation. Having arrived at this point in the production of rubies our experiments could no longer be instituted in our laboratory and required larger proportions. We therefore addressed the celebrated glassmakers, Messrs. Appat, who with great affability placed their furnaces and smelting pots at our disposal. We consequently continued our researches and produced the large ruby crystals, and also studied the relations existing between the sapphire and the ruby

"In nature it has been found that rubies will turn into sapphire and in spots exhibit blue colorization. We have reproduced this phenomenon in our synthetical experiments, as we have often found in the midst of the rose-colored ruby crystals those of violet or bluish hue. We even submit to the Academy handsome sheets of crystals rose-colored on one side and blue on the other. This occurrence appears to solve the difficulties urged on the causes of the colorization of the sapphire and that of the ruby. On beholding the same pot producing both rose-colored and blue-colored crystals it is difficult not to believe that it is the same metal, perhaps the chrome oxidized differently, which has caused the colorization of the ruby and of the sapphire.

'In order to complete the synthesis of the ruby one interesting question awaited solution at our hands: Can the ruby crystals which we have produced and which exhibit

the characteristics of the natural product, be employed in the same manner in the industrial pursuits? Do they possess the same degree of hardness of precious stone? Can they be employed in jewelry and horology? Practice alone could decide these questions. A very competent scientist, Mr. Taub, kindly assisted us and had our small rubies cut into roses and submitted to lapidaries our uncut stock, such as issues from our pots, and which may be employed as jewels in the manufacture of watches. Their hardness has been found equal to that of the natural stone."

Mr. Fremy has at the Museum of Natural History exposed the results of his remarkable experiments and has kindly authorized us to reproduce them by photographic illustrations: fig 1, shows a large pot about 25 centimeters, scant 10 inches, lined with rubyc rystal. Below is a fragment of crucible filled with crystals, freed from their ganque. Fig 2 shows three pieces of jewelry set with artificial rubies interspersed with diamonds. In the crescent the rubies have been set in their crystalline shape, while in the other two they were cut by the lapidary. These pieces of jewelry, of natural size, show the exact dimensions of the artificial product.

The rubies of Mess. Fremy and Verneuil are not very bulky, but these experimenters declare that they will press on in the essays in which they are at present so brilliantly engaged. And we hope that at an early day we will be called on to record greater success in their experiments of synthetical chemistry.

Many of these rubies are imported by dealers in jewels in this country, who place them in the market for just what they are—"reconstructed" rubies. If Messrs. Remy and Verneuil should ever succeed in produc-

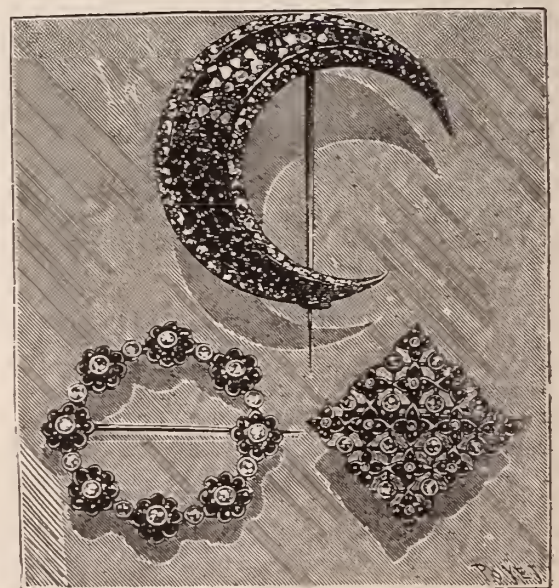

FIG. 2.

ing gems that are clear and limpid there is no doubt that many more of them will be handled by jewelers. They look well and set well; but, after all they are but imitations, however well they may appear.

Queries and Answers.

Feb. 5, 1891.

To the Editor of *The Jewelers' Circular* :

WILL you please tell me, through *THE CIRCULAR*, how to cleanse quicksilver? I have a regulator with mercury cells. I have tried many ways and as yet have not reached the remedy. If you can enlighten me it will be a favor to

BENJ. F. MAYO.

P. S.—The quicksilver in the cells is the same I purchased with the regulator, and the mercury has a foreign matter all through it, that is like molten lead.

Quicksilver, as it appears in commerce, is of two kinds, viz.: distilled or pure quicksilver, and quicksilver as it comes from the mine, or impure.

The only apparent impurity sometimes contained in distilled quicksilver is sulphur, which will show itself on top of the column in the jar of a mercurial pendulum.

Dirt and dust will often mar the brilliancy of distilled quicksilver when contained in the glass jar or cells of a mercurial pendulum. Distilled quicksilver may be effectually cleaned of dust and dirt by letting it run through filtering paper formed into the shape of a funnel, leaving at the small end a hole about the size of knitting needle. This paper funnel is to be placed in a glass funnel to sustain it. If not entirely successful with one operation, a repetition will accomplish the object. Impure or non-distilled quicksilver cannot be cleansed by mechanical means, and from the description it may be inferred that the quicksilver under treatment is of this kind. Age will improve it, as most impurities will gradually float to the top, their specific gravity being less than that of the quicksilver.

To Apply Plating and to Remove It.

DANVERS, MASS., Jan. 30, 1891.

To the Editor of *The Jeweler's Circular* :

CAN you recommend any good little battery to be used for gold, silver and nickel plating? Something that would be large enough to plate a tablespoon with. It should have some material to go to work with and be accompanied by an instruction book. What would be the cost?

How can I remove old gold plating from a silver case so as to make it look well?

SUBSCRIBER.

The Bunsen battery would, perhaps, be the best for our correspondent. The price per cell is \$1.75. One is just about large and strong enough for one tablespoon, one watch-case or six buttons. If he desires a battery for say about six spoons he must procure two larger cells, each of which will cost about \$2.50. The books of instructions he must procure for himself. There are various excellent works in the English language on the subject. We mention two: Urquhart, Electroplating, price \$2.00; Watt, Electro-Deposition, \$3.50. Either of these would be

excellent for the beginner. They can be obtained through *THE CIRCULAR* office.

Old gold plating may be renewed by polishing, by using the battery, reversing the poles, or by boiling in a strong solution of cyanide of potassium and finishing by buffing.

Trouble Over a Jewelry Bargain.

Luke Cooney came to Chicago from an interior Illinois town recently and entered a jewelry store on State street, near Van Buren, to buy a diamond pin. He selected one and paid \$10 down and then looked at a ring. He became involved in a dispute with the salesman, George Houston, about the terms of purchase, and as a result the first bargain was declared off. Cooney could not recover his \$10 or the pin and caused Houston's arrest for larceny. The latter was arraigned before Justice Randall H. White and held for trial under \$200 bonds.

How Ideas Change.

TWO retailers were discussing the relative effectiveness of colored and white back-grounds for the display of diamonds in show windows. One of them very eloquently asserted his opinion that a contrast between the white gems and a mat of black, blue or gold stuff was most attractive. The other said he always displayed his diamonds on white. He was equally positive that it was the most attractive and emphasized the purity of the stones. It was amusing a few days later when passing the window of the stickler for white, to observe that he had been influenced somewhat by his rival's arguments, for a brand new old-gold tray, ablaze with sparklers, held the place of honor in his display, but it was more amusing to stand before the other dealer's window and gazed upon a rare assortment of unset diamonds, nestling upon a snow-white background of batting. This incident shows how, by comparison, one's ideas are apt to change.

HENNEGEN, BATES & CO.

BALTIMORE, MD.,

Manufacturing Jewelers,

DIAMOND IMPORTERS

AND JOBBERS

IN ALL GRADES

AMERICAN WATCHES.

GOLD, SILVER AND NICKEL CASES.

Cor. Baltimore and Charles Streets.

M. ZINEMAN & BRO.,

MAKERS OF

"DIAMANTA" SPECTACLES & EYE-GLASSES

130 SO. NINTH STREET, PHILA., PA.

AMERICAN AGENTS FOR

MUELLER'S · ARTIFICIAL · HUMAN · EYES,

IMPORTERS OF ALL KINDS

Opera Glasses and Field Glasses,

FOLDING POCKET OPERA GLASSES.

MAKERS OF ALL KINDS OF

Trial Cases and Instruments for Measuring Eyes

IMPROVED PERFECTION TRIAL FRAME.

Send for Catalogue and Price List.

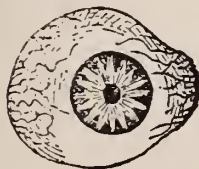

HOW TO RECOGNIZE THE TRUE

WEBSTER-WHITECOMB · LATHE.

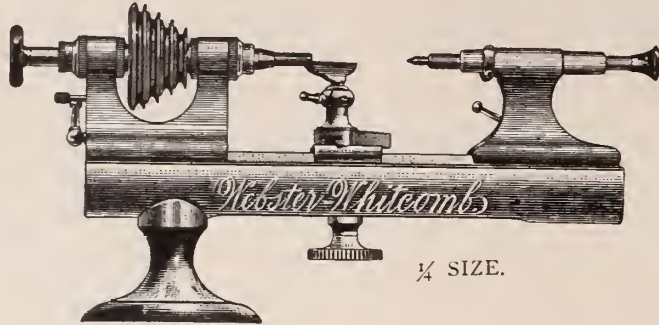

THIS question is often asked: "How shall I recognize an *imitation* from the *true* 'Whitcomb' or 'Webster-Whitcomb' lathe?" To this we reply: "All our lathes bear the word 'Whitcomb' or 'Webster-Whitcomb' also the word 'hard' or 'soft' to indicate the temper of the bearings, also the number of the lathe (all of our lathes being numbered consecutively) either on the bed or the headstock (latterly on the headstock only). The bed always bears the words 'American Watch Tool Co., Waltham, Mass.' The words 'Whitcomb' and 'Webster-Whitcomb' are our trade-marks, and up to the present time no imitator has dared to use them. The first attempt to use them or our patented features will be immediately followed by a suit at law. With every lathe we send the following guarantee:—

"This certifies that the lathe marked 'American Watch Tool Co., No. —' was made by us from the best materials, on the most approved plan, and is a reliable lathe. For any defect in material or workmanship we hold ourselves responsible. Notify us promptly of any faults.
Waltham, _____ By _____"
AMERICAN WATCH TOOL CO.

This guarantee is also signed by the inspector who has the final inspection of the work. For several years past we have tied upon every lathe a tag of caution and instruction. All purchasers are requested to demand these documents with the lathes they buy. Remember our address:

AMERICAN WATCH TOOL CO.,
WALTHAM, MASS.

STONEY BATTER WORKS.

ATTENTION!
ALEX. WIEDERHOLD,
20 MAIDEN LANE, N. Y.,
Repairing Jeweler.

Jobbing sent to me by mail or express will be repaired and returned promptly. Prices Moderate and First-class Workmanship Guaranteed.



The

Remington

has set the copy for writing machines for 15 years. It is to-day the

Standard

and expects in the future, as it has in the past, to lead all others in adding improvements to what will always be the true model of a

Typewriter.

Wyckoff, Seamans & Benedict,
327 Broadway, New York.

WE DESIRE to call your attention to our large and varied assortment of

Complicated, High Grade Gentlemen's and Ladies'



In Gold Cases, both Plain and Enameled, in Choice Designs.

THE LARGEST STOCK EVER SHOWN IN THIS COUNTRY.

NON-MAGNETIC WATCH CO.

OF AMERICA,

CHAS. McCULLOH, RECEIVER,

177 Broadway. - - NEW YORK.

TRADE GOSSIP

Jas. S. Knowles, H. G. Ely and W. S. Ely, travelers for S. F. Myers & Co. in different sections of the country, departed on Monday with "loads" of new things to please the trade. Messrs. Woand, Holkins, Wise, Cooper and Rider, more of the firm's "hustlers" are in town this week.

The new 18-size seven jeweled nickel memento, with open plates showing the train, made by the Trenton Watch Company are very attractive in appearance and will, no doubt, meet with a ready sale especially among watchmakers desiring a good watch at a low price. In the production of this movement the Trenton Watch Company have done themselves proud.

The Courvoisier Wilcox Mfg. Co. have now placed on the market their new "Standard" case. This case is 10-K. plump, made in 0 and 6 sizes, and in style and finish is unsurpassed. The designs in which it is made are equal to those of 14-K. goods. Altogether the "Standard" is a first-class case in every particular, and will undoubtedly prove a success. It is an entirely new venture with the manufacturers, as they have not been making 10-K. goods.

J. B. Bowden & Co. say that their business so far this year is in advance of that of the same period last year, and the indications are of an increase. One of the factors of this pleasant state of affairs is the steadily heavy demand for their "seamless" ring, which has achieved a complete success. Being stamped from a solid piece of gold, the sentiment of endlessness or eternity which the ring contains, is especially pleasing to the ladies.

All dealers should send for the new catalogue of the Waltham Watch Tool Co., Springfield, Mass. The pamphlet contains full descriptions and particulars of the Hopkīns' lathes and attachments. These appliances have been well-tried, and their beauty and excellent finish, together with the accuracy of their parts warrant all the appreciation they have received from jewelers. Lathes of American make are pre-eminently the best, and if they are slightly more expensive than the foreign product their service and durability fully overcome the excess.

The attention of our readers is directed to the advertisement of the Chrome Steel Works, which appears on another page. It is certainly of supreme importance to all jewelers wherever located to know that the safe containing their valuables is made of the best material and is burglar-proof. A safe to be burglar-proof must be lined with at least one layer of the only known thoroughly tool proof metal made, viz.:—five-ply welded Chrome steel and iron made by the Chrome Steel Works, Brooklyn, N. Y. If you contemplate

ordering a safe to be lined with this material drop the Chrome Steel Works a line stating to whom your order will be given. They will protect your interests by seeing that their material and not a cheap imitation is used in the safe's construction.

The Audemair oculists' trial-case will continue to be a strong feature this year with the Spencer Optical Manufacturing Co. The success of this case has been almost phenomenal and is rapidly assuming prominence in the best eye hospitals. The New York Ophthalmic Institute has had one in daily use in the consulting room for the last three years and has showed its appreciation of it by ordering three more a few weeks ago. The firm's advertising man tells why it is a preferred article in the following verse:

"The old 'nachel' was a good enough case,
When no other case could we see;
But as it is expensive and old and cannot be sold,
It is not the trial case for me.

The "Audemair" case is the right trial case,
It's accurate, it's cheap and it's neat;
So it's no use to bother or try any other,
For Audemair cannot be beat."

One of the most ingenious men in the trade is Julius Wodiska, 49 Maiden Lane. His ingenuity is not confined to the manufacture of jewelry. Besides the several successful devices in that line which are the fruit of his fertile brain, he has invented mechanical systems and appliances which are evidence of the inventor's research and hard study. The latest product of his skill is an oaken gavel made from timber taken from the threshold of the Reformed Dutch Church in Delfshaven. A silver plate on the top of the gavel showed the coat of arms of the village, consisting of a herring and a sheath of wheat divided by a green enamel shield with black and white enamel lines. Twining about the handle was a silver ribbon bearing the in-

scription: "This gavel and box were made from timber taken from the Reformed Dutch Church at Delfshaven, Holland, built in 1416." The box referred to is covered with seal leather; on top is a 4x6 silver plate bearing the Dutch and American flags crossed. This gavel and box formed a presentation gift to the Holland Society at their annual dinner at the Lenox Lyceum on the night of Jan. 20. John Rutgers Planten, Consul-general of the Netherlands, was the donor.

Parties who desire the very finest watch repairing done should send their work to John D. Simmonds, 18 John street, New York, as he is one of the best horologists in the country.

G. F. Feinier, who has recently opened a factory for the manufacturing and repairing of watch cases, at No. 9 Bond street, New York, is doing a good, brisk business. Mr. Feinier was with the American Waltham Watch Company for a long time, and the experience he got there stands him in good stead in his own business. He is a practical man.

The success of the patent spring back stud manufactured and controlled by Larter, Elcox & Co., 41 Maiden Lane, New York, is unabated. It is one of the most ingenious and perfect devices in jewelry ever produced. In its operation it is simple and unlikely to get out of order or break. The stud is made in four sizes of polished, Roman gold, moonstone, white onyx, either plain or with diamond centre, and white enamel with linen finish; each variety has its own share of popularity. A selection package of these studs will be sent on application. Larter, Elcox & Co. also manufacture a large line of rings, including ladies' fancy, gentlemen's seal, and children's rings; also stone and gold sleeve buttons, stone locketts and stone seals.

NOTICE.

Intending to retire from business, we offer for sale our fine stock of *Diamonds, Rubies, Emeralds, Sapphires, etc.*, either the *whole* or in *lots* of any size. *Also fixtures*, consisting of fire and burglar-proof safe, desks, cloth-covered tables, diamond scales, office partitions, etc., etc.

This presents a fine opportunity for a party to purchase a successful business, with a first class *clientelle*. Part of office to rent.

PETERSON & ROYCE,

189 Broadway, New York.

Whose Silver is This?

DULUTH, Minn., Feb. 11.—There rests in an obscure corner of a closet in a railway office in this city, a very strongly-built trunk, whose somewhat bruised exterior shows the marks of hard service during its journeys which must have been frequent. It arrived here over a year ago in a box car which was supposed to be empty, but which contained simply the trunk. It was locked and no way-bill for it was ever found. After considerable telegraphing along the railroad lines over which the car had passed, and no clue to its ownership having been discovered, it was opened to see if the contents would not disclose the name of the missing owner. But the revealed contents only deepened the mystery, for it was full of a large amount of sterling silver forks, spoons, knives and other silver articles of table ware. The road detectives and several detective agencies were at once notified, as the property bore the marks of several owners and was evidently stolen, and the whole lot was evidently the "swag" or booty of some burglars' raid. It is in the custody of the officials of the road in whose car it was found, and still awaits a claimant who can give a good account of ownership. The trunk had evidently been placed in the empty car by the thieves as a temporary hiding place and the removal of the car made the claiming of the trunk a very risky piece of business.

An Alleged Real Estate Dealer Works a Clever Scheme.

DULUTH, Mich., Feb. 11.—A clever swindle was perpetrated upon Holth Brothers, jewelers, by a man who claimed to be a Mr. Williams, of Williams & Schlappi, 501 Palladio building. He had tickets printed for the raffle of a watch for a sick person a day or two ago. Previous to the raffle taking place he went to the jeweler and purchased a watch with chain and locket, valued at \$70. Handing Mr. Holth his business card, he explained that he had not enough cash to pay for the same and tendered a check for the amount. Finding Mr. Holth willing he changed his mind, saying he would make the check for \$100, asking him for \$30 cash, which the unsuspecting jeweler agreed to, when he left with the watch and chain. The next day, however, he returned and explained that he could not meet the check that day, but would give him a draft payable February 5. Mr. Holth accepted the draft and sent it to the wholesale house with which he deals. Yesterday the draft was returned dishonored. The detectives are in hot pursuit of Williams, but no trace of him had been learned late last night.

Singular Coincidence.

F. Crake, the well-known watchmaker and jeweler of New Westminster, N. C., tells a singular story. A gentleman dropped into Mr. Crake's shop the other day and left an old-fashioned watch to be repaired. On opening the case Mr. Crake found that he had repaired the same watch exactly thirty

years ago, in a town in one of the midland counties in England. Mr. Crake's name was scratched inside with the date and year when it had last been in his hands. That the watch should again come into Mr. Crake's hands for a similar attention after a lapse of thirty years, and in a country thousands of miles distant from where he had last seen it, is an occurrence of more than ordinary interest.

Cheshire Clock Company.

WATERBURY, Conn., Feb. 11.—A lot of machinery belonging to the Cheshire Clock Company, was bought at an auction sale Tuesday, by Frank E. Morgan, secretary of the New Haven Clock Company, for \$600. Mr. Morgan says that the machinery was bought for himself personally and that the purchase had nothing to do with the New Haven Clock Company. The Cheshire Company has done no work for three years and the material sold was the last of its equipment.

Schroeder and McCabe Held.

CHICAGO, Ill., Feb. 11.—John Schroeder and Pat McCabe, the two young men arrested last week for breaking a window in a jewelry store on Chapin near Noble street, were before Justice C. J. White yesterday. They were held to the Criminal Court in bonds of \$1,000 each. A third member of the gang of window breakers escaped and is still at large.

A Missing Jeweler.

MONTREAL, Feb. 13.—Mr. C. Swenson, jeweler, 657 Craig street, is missing. He has not been seen since Monday. He was doing a good business. He is a bachelor of about 55 years of age, has been established here for over fifteen years and bears a good name. Many suppositions are afloat concerning his disappearance. Swenson was in the habit of carrying large amounts of money about him and there are fears of foul play. Detective Robinson went yesterday morning to Mr. Swenson's store, where the dust all over the place was a clear proof that nobody had been in for several days. The store was well searched but nothing was found, and the stock, which is a valuable one, had not been touched by anyone. Last year Mr. Swenson had a severe attack of grip and has never been the same since, and his friends think that he has done away with himself in some way, as his revolver, which was always kept in the store, is missing. He was very well known in the city, and owned considerable property on Lagauchetiere street, and it is known that at the time of his disappearance he had to his credit in the bank over twelve thousand dollars. There also are suspicions of foul play.

A Thieving Shoemaker.

LEADVILLE, Feb. 6.—Adam Fischer, a shoemaker, was arrested last night while leaving a building in Harrison avenue which had been robbed a few hours before. Officers

were sent to his room where they found goods of every description. There were gold watches, chains, diamond rings, and other property valued at about \$7,000. Fischer had \$700 in cash on his person, and a certificate of deposit for \$700 on the American National Bank was found in his room. Fischer had evidently scratched out the name of some person and inserted his own. A letter found in the room leads the officers to believe that Fischer had a confederate in San Francisco to whom he sent stolen goods.

Stolen from the Mails.

CHICAGO, Feb. 8.—Louis Donelson, a car driver, offered a lot of bracelets to a pawnbroker on February 7th, saying that if he could get money on them he could produce more of the same kind. He was arrested and two dozen more of the same style were found in his pockets. The bracelets were worth 1.75 each. The bracelets were part of a consignment sent to Giles Bros., this city, from a Providence house. It is said that they were stolen from the mails, and the police are trying to detect the thief.

A Crook's Neat Story.

PITTSBURG, Pa., Feb. 11.—A \$200 diamond pin, part of the jewelry stolen from No. 111 First avenue, a few days ago, has been recovered by Detective Bendel. The thief took it to a pawnshop, where he gave the name of S. Lowenthal. He told a very neat story, saying he was the advance agent of a theatrical company, and was temporarily embarrassed for funds with which to get the baggage from the railroad. The policeman on the beat had sent him to this pawnshop, and he would like to borrow \$60 on the pin. He got it.

The man at once left town, carrying with him a diamond bracelet valued at \$600, which he can dispose of at his leisure.

Swenson Still Missing.

Later.

MONTREAL, Feb. 14.—During the last two days several persons have applied to the police to get goods, which had been left at Mr. Swenson's, returned to them. This morning the Chief of Police was granted an order from Justice Mathieu to bring the safe and all the jewelry in the store of Mr. Swenson to his office and take charge of it. Detective Robinson has searched the city and the municipalities, but has not been able to find any trace of the missing man. Swenson was seen at three o'clock on Tuesday morning by two policemen of No. 5 station. He was then on Craig street. They asked him where he was going and he told them he was going for a walk as he could not sleep. He added that while dozing he had heard a dog howl, and it reminded him of a dog he heard howl in the Franco-Prussian war. Chief Hughes says that Swenson was worth \$20,000.

The Retail Trade.

Annual Convention of the National Retail Jewelers' Association.

A Successful Gathering in Philadelphia, where Trade Topics were Discussed, and which Wound Up with a Banquet.

THE second annual convention of the National Retail Jewelers' Association was held on the 11th and 12th insts. in the hall of the United Order of Friends, No. 1128 Arch street, Philadelphia.

Although the hour fixed for the assembling on the first day was 9.30 o'clock, it was fully two hours later before the delegates and members had congregated in sufficient numbers to justify the President in calling the meeting to order. The roll call at this session showed an attendance of about 20 officers and members, but the number was constantly increased until, at the close of the morning session, it was found that the attendance had more than doubled. When the convention finally got down to business, it was presided over by President Arthur S. Goodman, of Philadelphia. J. G. Maree, of Manayunk, acted as Vice-President; and George Hoffman, of Philadelphia, as Secretary.

Vice-President Maree, who has been in the jewelry business for nearly half a century, welcomed the delegates and members to the convention, and congratulated them upon the fact that although the attendance at the opening was small, it was much larger than at the opening of last year's meeting.

The only business transacted at this session was the reading of reports of Assistant Secretary Hoffman and of Treasurer Haines. They showed an encouraging state of affairs, the condition of the exchequer being particularly pleasing. The membership has been increased during the past year by 99 additional names, thus doubling the total membership. During the year the treasurer reported the receipts amounted to \$1,119.97, while the expenditures aggregated \$782.96, leaving a balance to the credit of the association of \$337.01.

During the past year the association has opened an exchange, or show room, at No. 715 Arch street, which, by the way, is only open to members. In it are arranged a series of departments used by members for the exhibition of novelties and special articles.

It was to this room that the delegates and members were taken during the recesses at the close of each session, and here many of them spent their leisure hours.

The afternoon session was the most interesting to the delegates, as it was devoted to the hearing of addresses, and of the President's Report. The latter was interesting alike for the facts shown, and the careful manner in which it was written.

The President's Report was as follows:

In accordance with the requirements of the Constitution and By-Laws the following is offered you as my first report as president of your association:

Before proceeding further on my agreeable task, I feel that the association is to be congratulated upon its progress, particularly during the time elapsing between the first public meeting held in January, 1890, and this, its second annual convention.

Its steady influx of membership, the prosperous condition of its finances, and the faithful attention that has been given to all the details that make a successful organization by its officers and board of directors, are something that should kindle a pride in every member interested.

Starting as we did with a handful of members, subject to ridicule, comments and adverse criticisms, we have gradually forced our way through obstacles enough to discourage any body of business men, until now we can justly claim the respect of both friends and enemies.

Many of those occupying seats around me know what difficulties were overcome, what discouragements were offset, how at times success seemed almost beyond our reach and many hours of time during the past year that have been devoted to bring the association to its present prosperous condition. It is my purpose, so far as my abilities lie, to present you with a brief list of the events of importance that have transpired since my election to this high office. When the members saw fit to place me in this position the association was known as the Philadelphia Retail Jewelers' Association. The fruitlessness of accomplishing any great amount of reform as a local institution in the way of trade abuses was early apparent, and that the quicker we became a National Organization the sooner would success meet us. It then became the aim of our efficient Board of Directors, seconded by myself, that in order to place ourselves in a proper light before the retail trade and solicit their aid and assistance, a charter should be procured that permitted us to become a national association with the privilege of organizing State and local branches, so that in the course of time should our efforts prove successful, the Retail Jewelers would be combined in one strong and effective body. Our laws were amended to meet the change and application made to the court for a charter.

Headquarters we established and furnished, and a Jewelers' Exchange founded.

The costliness of reaching jewelers by mailing had for some time engaged the attention of the Association, and a more effective and cheaper method became imperative, by which proper arguments could be used to influence retail jewelers in becoming members. The desire for an official Journal became paramount, and while the then limited state of the finances hardly permitted such an outlay of money, yet a plan was eventually formulated by which the paper became

an assured fact and the *National Retail Jeweler* surprised the retail trade on April 1, 1890. After two issues the company having the same in charge made a change in editorship, and as you are all aware, the same devolved upon me. The paper has since appeared with unflinching regularity.

In July last a pleasant public meeting was held at Atlantic City. The principal event of importance transacted there was the condemnation of watch companies permitting their products to be sold by pews-papers.

The illegal batch next engaged our attention the results of which you all are familiar with.

In conclusion I cannot refrain from publicly thanking the officers and members for the assistance extended to me in my duties; also the many courtesies of which I have been the fortunate recipient during my term of office. It is my sincere hope that the same friendship and co-operation will be mine during the coming year, as it has been during the past; and that the purpose that has identified me with the success of our association will be as clearly manifested in the future as it has been in the past.

After the reading of the report, Dr. F. Ogden Stout, of New York, delivered an address on "The Art of Fitting Glasses Intelligently." His explanation was for the sole benefit of jewelers who carry on the business of fitting and selling glasses. He wisely avoided the use of technical language. He showed the simplest methods of ascertaining and correcting visionary defects, and concluded by making a test upon delegate S. L. Thums.

Following Dr. Stout, the president spoke of the necessity for organization, under the topic "Why an Association of Jewelers is a Necessity." He maintained that with jewelers, as with all other craftsmen, organization is beneficial, inasmuch as it keeps the jewelers before the public, gives them an opportunity to discuss and avoid dangers in business, and is for their mutual protection.

Simon C. Levy, of Philadelphia, talked in the same strain, his subject being, "The Benefits Derived by Being a Member."

Mr. Levy's talk closed the day's session, and the delegates spent some time subsequently in the show rooms. In the evening some went to their homes nearby while many attended the theatres.

SECOND DAY'S SESSION.

The second day's session was held with an increased attendance, but the delegates were tardy in arriving, and it was after eleven o'clock when President Goodman pounded the desk with his gavel and called for order.

As the session was to end before one o'clock there was not much time, but fortunately, no business had been arranged, except for the afternoon. According to the programme the

Our special offer on the two popular numbers of Willson's Spectacles, Nos. 184 and 155, advertised by us in last week's CIRCULAR, has made a notable impression on the Trade, and the goods are going to all parts of the United States. We limit the quantity to be thus sold to 250 gross, and judicious buyers will not delay in ordering, as after that quantity has been sold we shall restore the price to the regular figure, 30 per cent. higher. In order to be able to furnish these staple grades at the great reduction we had to buy the largest quantity of these particular numbers ever sold to any one jobber in the United States. It is your opportunity. We furnish them in both Blue Frames and Nickel Plated.

Bowman & Musser, Importers and Jobbers,

Watches, Chains, Spectacles, Tools and Materials.

Lancaster, Pa.

entire morning was to be devoted to general discussions, in which the floor was open to every member or visiting jeweler. There were several who took advantage of this, and they spent what little time they could command, in a really social time. Formality was entirely abandoned for the time, and those informal talks were indulged in by President Goodman, Vice-President Marie, George W. Boetlinger, of the firm of Boetlinger & Walters, Baltimore, Isaac Hertzberg, of Philadelphia, and some others.

After dinner an executive session, the only one during the convention, was held for the consideration of important matters. Secretary Hoffman read the minutes, and then filed a number of applications for membership.

Under the head of unfinished business, the convention considered and adopted several amendments to the by-laws, the only one of importance being that which gives to the Board of Directors the executive control of the Association.

This is done in order to facilitate business, and to give the Board an opportunity to meet frequently. Its members, subsequently elected, were chosen; with but few exceptions they were from residents of Philadelphia. The convention decided to have 500 copies of the amended by-laws printed.

Following the adoption of these amendments, an election of officers to serve during the ensuing year took place, and resulted as follows:

President, Arthur S. Goodman, No. 270 South Fifth street, Philadelphia. First vice-president, James G. Moree, Manayunk. Second vice-president, G. S. Katz, No. 1,929 Germantown avenue, Philadelphia. Secretary, Simon C. Levy, No. 1817 Ridge avenue, Philadelphia. Treasurer, William Haines, No. 1226 Columbia avenue, Philadelphia. Board of Directors, J. R. Hamer, Isaac Hertzberg, C. L. Conrad, R. Pinkstone, J. Shulier, George Hoffman, J. V. Smith, F. C. Bode, Jr., C. B. Lynch, C. Lingg, E. H. Williams, William H. Long, and S. L. Schumo, all of Philadelphia; E. Langensdorf, of Camden, and W. H. Bovard, of Manayunk.

All of the officers above named were in attendance during the convention, and besides them were noticed:

M. M. Bovard, of Manayunk; M. H. Woodhull, Keyport, N. J.; John C. Sheldon, Mechanicsburg Pa.; J. B. Janssen and John Tansley, Germantown; J. Heath, Lambertville, N. J.; J. A. Fiedler, Milton, Pa.; F. Brunner and H. E. Travis, New York; A. W. Simon, Tremont, Pa.; A. Bernhard, Easton, Md.; Frank Kline, Spring City, Pa.; F. D. Woodruff, Riverhead, N. Y.; F. Street, Keyport, N. J.; J. W. Wagner, Mifflintown, Pa.; O. O. Stillman and E. B. Howitt, New Brunswick, N. J.; Mr. Mayall, Boston; Rufus E. Shapley, Mechanicsburg, Pa.; and the following Philadelphia tradesmen: John Perrin, Charles Lynch, Frederick Bode, Jr.; R. Bottomley, E. Sanborn, of E. Sanborn & Son; A. Groth, J. V. Smith and F. H. Smith, of Smith & Son; C. Liggins, R. W. King, James Orr, Robert W. Fischer, D. Harman, Charles E. Lewis, A. Herzberg, Oscar Spiess, Charles Rees, A. J. Callaway, George M. D. Lewis, A. H. Kennedy and J. W. Forsyth, Jr.

THE BANQUET.

The convention terminated, as all well regulated conventions do, with a banquet in the evening. It was held at Reisser's and covers were laid for one hundred guests. Of the expected one hundred, there were over eighty who sat down at the word of command from President Goodman, who occupied the head of the table, with first Vice-President Moore on his right, and second Vice-President Katz on his left. The delegates and invited guests discussed and thoroughly enjoyed the following menu.

- Raw Oysters, half shell.
- Purée of Celery a la Crème.
- Fried Oysters.
- Lobster and Chicken Salad.
- Croquettes of Sweet Bread, French Peas.
- Roast Turkey, Cranberry Sauce.
- Lettuce en Mayonaisé.
- Cabinet Pudding.
- De Brié.
- Cigars.
- Coffee.

After the necessities and luxuries were disposed of, President Goodman rapped for order, and in a few well chosen words, introduced Vice-President Moree. The latter responded in a happy vein. Among other things he said that the great object of the association is to correct abuses in business. The speaker could readily recollect the time when the dealer in jewelry confined himself entirely to that business, and it was exceptional for any one outside of the business to handle jewelry. In those days the jewelers refused to have any business connection with such outsiders. Spurious or imitation articles were readily detected by the finish. Now, however, the production of manufac-

tures of these goods can be so wonderfully like the genuine article that it is not only difficult to tell from appearance, but is crippling the legitimate trade.

Following Mr. Moree, the president spoke of the future of the retail jeweler, and said that if things continue as they are now, it is doubtful if there will be any exclusively retail jewelers in the future. The business, he said, is so encroached upon, that his conclusion seemed to be justified by the facts.

Mr. Goodman wanted to correct the impression that there is an undying enmity between the members of the association and the wholesalers. He and all members considered the retailing by wholesalers to be unjust, and it was the aim of the organization to have each business conducted in its proper channels.

The wholesale men, he said, are more level-headed than the retailers, and they showed this some time ago by forming a permanent organization that is making wonderful progress. The work of doubling the membership of the retail association, was performed in the face of adverse circumstances, criticism and ridicule. Mr. Goodman urged the members to spend the year in doing missionary work for the benefit of the association.

George B. Kelley, secretary of the Rockford Silver Plate Company, of Rockford, Ill., said the trouble with retail jewelers is that they are too courteous, and take too much trouble to point out to prospective customers the various works and numbers, showing the quality of goods. With information thus gained, the visitors to retail stores go to dry goods and other establishments and find these imitation goods that appear to be like those previously seen. The speaker did not know how it was in Philadelphia, but in the West there are no strictly first class jobbers who engage in the retail business.

Speeches were also made by Isaac Hertzberg, of Philadelphia; Secretary Simon C. Levy, H. Z. Openheimer, of the firm of H. Z. Openheimer & Co., No. 48 Maiden Lane, New York; J. Odenheimer, of New York, patentee of the initial ring; Frank J. Jones, of New York, of the Jewelers' League. H. B. Summers, of the Philadelphia Watch-making firm of H. D. Summers & Co., Mr. Kiefer, of the Philadelphia firm of Kiefer &

TELL A. BEGUELIN,

IMPORTER OF

WATCHES,

Watch Materials, Tools and Glasses,

No. 71 NASSAU STREET,

(UP STAIRS.)

Cor. John Street, NEW YORK.

Sole Importer of Material for the

"Bijou," "Victor," "Boston," "Bristol," "Adelphia," "Jockey Club," "Wallingford," "Caesar," "Lady Racine" and "New Haven" Watches.

AMERICAN WATCHES.

ALSO STEM WIND WHEELS.

IMPORTER OF

Full Line of SWISS WATCHES,

ALSO IMPORTER OF

FRENCH CLOCK GLASSES.

A PLAIN SOLID GOLD RING IS A SMALL ARTICLE—BUT WE

MUST HAVE 'EM—AND THE PLACE TO BUY THEM IS OF

HILDRETH MANUFACTURING COMPANY,

53 MAIDEN LANE, NEW YORK.

TO BE CONVINCED SEND FOR PRICE LIST.

Deshamps, and H. Reimold, of the American Printing House.

The evening was very agreeably passed, and the business of the convention was finished to the entire satisfaction of all.

All of those who attended the session of the convention were present at the banquet, and in addition others were noticed.

Philadelphia.

George W. Banks, of Bailey, Banks & Biddle, has left for Havre, France, for a nine months trip abroad, Mr. Banks is accompanied by his family.

Edward T. Taylor, formerly with William G. Earle, the watch club man at Ninth and Market streets, has opened a retail store on the second floor of No. 939 Market street.

Joseph T. Bailey, of the firm of Bailey, Banks & Biddle, Chestnut street jewelers, has for some days past been confined to his Twenty-first street residence, by a sprained ankle received at his place of business.

Frederick Baker, at one time a member of the firm of R. P. Davis & Co., jewelers at Twelfth and Sansom streets, has gone into business on Sansom street near Eighth. He will make a specialty of diamond setting.

James A. Haas and J. Philip Fraw, late trading as Haas & Fraw, Market street jewelers, have obtained a verdict in the Common Pleas Court for \$75.09 and costs against W. D. Rodgers, in a suit to recover for jewelry sold and delivered.

Simons Bros & Co., the Chestnut street jewelers, have obtained a verdict in the Common Pleas Court for \$86.42, against Patton & Cobb, manufacturing jewelers, on Sansom street, in a suit for the recovery of the value of goods sold and delivered.

The first house to put the new sixteen size Waltham pendant set watch cases on the market in this city, will probably be that of Bernard Levy, on Ninth street below Sansom. Mr. Levy is now having the dies made

and he expects to get the new article on the market in three or four weeks.

A National Convention of jewelers is a new idea. That men who can look into the cold business eye of calculation and trade upon such a sweetly sentimental piece of diamond and gold poetry as an engagement ring have soul enough left for social communion with their fellows seems something of an anomaly in nature.

Louis P. White, agent of the Dueber Watch Case Company and the Hampden Watch Company, who has his offices at No. 631 Chestnut street, is making some necessary improvements in the place. About a year ago Mr. White began to sell fine French and American clocks and bronzes, and this branch of the business increased so rapidly that he found it necessary to provide more room. He recently took the office adjoining his own and, knocking down the partitions, began to improve it. He is having a number of fine shelves built for the display of goods.

Canada.

Montreal retailers complain of the dullness of the season.

Edmund Scheuer, of Toronto, has been in Quebec city on a business trip.

J. Jones, of Brussels, Ont., has moved from his late quarters to the Vanstone Block, a very promising location.

William Eaves, one of the best known jobbers in Canada's jewelry trade, who has been dangerously ill for some time is now out again.

R. Mercer, of Toronto, has bought the jewelry stock of the late H. D. Young, of Seaforth, Ont., and will carry on business in the latter place.

Jewelers in the vicinity of Ancaster, Ont., are receiving circulars from the police authorities asking them to watch for parties offering at large diamond ring for sale. The ring was stolen from the house of John His-

lop, a county official who was recently mysteriously murdered at Ancaster.

Lilian Davison, the ten year old daughter of the late M. A. Davison, of the firm of Davison & Felters, Halifax, died of diphtheria on Sunday, February 8. Thus in the course of a few weeks Mrs. Davison has lost her husband and child.

Louis Davis, C. Bolt, Henry T. Miller and Henry Joshua Joseph, manufacturing jewelers, formerly carrying on business in Montreal, under the name of Bolt & Co., have now registered under the name of the Dominion Rolled Plate Co.

The firm of Weinrobe & Blackson, of Montreal, has been dissolved. They were large dealers in American watches, carrying them into the lumber camps of the country, and at the same time running a store in Montreal. Mr. Blackson now has the store in hand and Mr. Weinrobe the traveling routes.

Nova Scotia.

Seizures of jewelry imported by Arabs from England are reported from St. John, N. B., for undervaluation.

The marriage of Mr. Charles Loup to Miss Meagher took place in Halifax on Tuesday morning. On Monday last Mr. Loup opened his store on Barrington street. His specialties are watches and clocks.

Indianapolis.

Nichols, Pee & Co., have entered the field as wholesalers, being the second strictly wholesale house in the city. Baldwin, Miller & Co. have held the field alone for years, and have an extensive trade in the West. Both report business prosperous.

Sims & Heaton, retailers on North Illinois street, near Market, are closing out to quit business. They carried a large stock, but concluded to invest their capital in other lines. They will retire from their rooms by the last of this week.

COMPARE

ALL OTHER GOLD FILLED CASES WITH THE CELEBRATED



**CROWN, LION,
EXCELSIOR
HAND ENGRAVED CASES.**



WARRANTED

MADE BY

H. MUHR'S SONS, 629-631 CHESTNUT ST., PHILA.



TO LET — IN THE FIREPROOF —
JACKSON BUILDING,
 Union Square, New York,
 STORE AND LOFTS, 28.6 x 184 Feet.

Will Be Ready May 1. Apply to

J. EDGAR LEAYCRAFT, 1544 Broadway, * *

—OR—

ALFRED E. MARLING, 150 Broadway.



Especially designed
for Jewelers' Offices
and Factories.

Wired for Electric
Light and Power.

Hydraulic Freight
and Passenger Ele-
vators.

Iron Beams with
Brick Arches be-
tween.—Fireproof.

Facing Union
Square.

In the centre of the
Fine Jewelry Trade.

Thoroughly Heated,
Lighted and Venti-
lated.

Containing every
modern comfort and
improvement.



St. Louis.

R. M. Ostrander has located at 309 North Ninth street.

D. A. Kusel, the optician, has left the Fagan building on Olive street for a location on Fourth street near Pine.

Morris Bauman is now managing the material and clock department for the L. Bauman Jewelry Company.

F. H. Niehaus, Treasurer of the Retail Jewelers' Association, who has been down with rheumatism, is about again.

George W. Colby, Sr., has removed from No. 300 Olive street to 205 North Fourth street, where he has a fine location with opportunity for a good window display.

H. C. Grawe, the Olive street jeweler, is awaiting a decision from the United States Court, which, if it is decided in his favor, will make him a rich man. Mr. Grawe took out letters patent on a device for cable crossings on street railways several years ago, and the Citizens' and Broadway lines have been using the invention without compensating the inventor. At least this is Mr. Grawe's contention in the suit which is now pending against the Citizens' Company.

Under the will of the late John Balland, John Z. Balland, his son, is made trustee and instructed to sell the stock of goods in the store on Fourth street and invest the proceeds in real estate. The valuable property on the southeast corner of Fourth and Olive streets was held by the deceased under a long lease from the School Board and the trustee is empowered to remove the present buildings and erect more modern structures if he believes such a course would be for the best interests of the estate. The trust is to last through John Z. Balland's life and the income is to be divided into fifths. The testator's widow, as long as she remains unmarried, is to have one-fifth, on relinquishment of her legal right to one-third of the estate. The three daughters and the son, John Z., are each to take a fifth. At the termination of the trust the estate is to be divided according to the devices of the participants in the fund or among their legal heirs. The homestead and household effects go to the testator's widow for life, or so long as she remains unmarried.

The heirs, being desirous of continuing the business, have mutually agreed to set aside the provisions of the will so far as it relates to the sale of the stock in the store at No. 8 South 4th street. A motion will be filed to this effect in the Probate Court this week. It has not yet been decided whether the business will be continued under the old firm name or not.

A new and important industry is nearly ready to begin operations here, the Missouri Onyx Company. This corporation has been organized by J. F. Leigton, President and Treasurer of the Providence Jewelry Company, to develop the onyx discoveries in Crawford and Pulaski counties, which are now known to be of great value. Careful examination of the caves owned by the com-

pany has brought out the fact that oynx in great quantities and of a remarkably fine quality, fully equalling, if not excelling the Mexican product, is easily obtainable in Missouri. The caves are near to the railroad track, and the product can be readily handled at a minimum of cost. The company is about ready to begin operations on a large scale. Mr. Guy H. Reynolds, of Rutland, Vt., has just left St. Louis, after having looked over the oynx field carefully. Mr. Reynolds is a well-known manufacturer in oynx. He pronounces the quality excellent and the quantity enormous, and has taken a large block of stock in the company, and has made an arrangement by which, if the company so desires, he will move his entire plant to St. Louis, and take charge of the manufacture of the product. Those interested feel that this is a very important connection, as the manufacturer in question has an extensive business and an established trade, and consequently the arrangement means a large benefit to our great State and city.

Brooklyn Jewelers Alarmed.

WHEN the employees of James H. Hart, Brooklyn, on Friday morning arrived at the handsome store, 539 Fulton street, they were astounded at viewing the demolition of one of the fine plate panes. An inventory of the goods displayed in the window showed that sixteen pairs of Audemair and Lemaire opera glasses and six opera glass holders, valued in all at about \$250 had been stolen. Previously patrolman Sauers had reported at the First Precinct Police Station on Adams street, that he had passed the store at 5.50 o'clock and had discovered the breakage, but in his passing at 5.30 o'clock he had not seen it. A newsboy has been found who claims to have seen the broken window at 5 o'clock. The police believe that the window was smashed by a twitch of a jimmy inserted between the sash and the edge of the glass. This would account for the fact that no sound of breaking glass was heard by the patrolman.

Mr. Hart has furnished the police with the numbers of the articles stolen, and it is hoped they will be recovered. But no clue of the thieves has been obtained, and it is unlikely there will be. The robbery is thought to have been the work of young loafers who prowl about the streets at all hours.

The matter has disturbed the equilibrium of the neighboring jewelers, whose establishments are among the richest in the city. In the distance of no more than a quarter of a mile, extending from DeKalb avenue, on the corner of which is Mr. Hart's store, to Boreum Place, are the stores of C. C. Adams & Co., A. A. Webster & Co., P. W. Taylor, Benjamin F. Spink, J. R. White Jewelry Co., and U. Straus besides James H. Hart. P. W. Taylor is agitating a system of protection to consist of alarm stations to be located at various points of a straight beat between the two above points, the patrolman on beat being compelled to strike reports at stated intervals.

The police advise the jewelers if it is desirable to keep goods in the show windows during the night that they be moved back out of reach.

Canton.

Mr. John C. Dueber arrived in Canton last Thursday for the first time since the assignment. He was seen by THE CIRCULAR reporter and said:

"I did not feel like coming back to Canton in the light of recent events, and it was a great trial for me to do so. The whole trouble came upon me suddenly and I was totally unprepared. It was like a thunder clap to me. Oh, yes, I can pull out. I never go into anything that I cannot pull out of. Now, when I know I am playing checkers with a man, I know what I am doing and watch my points and never get into any hole out of which I can't see my way. But when I am playing checkers with a man and don't know it, then I am unprepared and am led into a trap. That is just the position I am in now. I didn't know I was playing checkers.

"This trap has been laid for me for ten years, and I was led into it, but I can get out again. I will stay in Canton and the works will not be removed. I always treat everyone fair, and when I am treated half-way right, I treat other people twice right."

Matters concerning the failure of the Dueber Watch Case Manufacturing Company of this city are about adjusted, and the indications are that both the Dueber and Hampden companies will be running full force by March 1. At Cincinnati, on the 12th inst., Assignee Howard Douglass notified the Probate Judge of Hamilton county that all of the creditors had agreed to raise the assignment. He also asked for power to secure the release of the Chicago property. No decision was rendered.

The Duebur works are now running with a small force, under the charge of Assignee Howard Douglass. The Hampden works are in charge of W. W. Clark. All of the salesmen are on the road, and it is said orders are coming in at a lively rate.

A Reorganization.

CLEVELAND, Ohio, Feb. 14, 1891.—The C. B. McElroy Jewelry Mfg. Co. has reorganized, Mr. C. B. McElroy having bought out old stockholders. The new board of directors is as follows: C. B. McElroy, President and Treasurer; A. A. Bemis, Vice-President; T. W. Minshull, Secretary; W. H. Bond, Wm. Debold.

R. A. Kipling

Importer of Precious Stones

31, Union Square
New-York

19, Rue Drouot
Paris

CROSS & BEGUELIN,

21 Maiden Lane, N. Y.

IMPORTERS OF

Watches, * *
Diamonds,
Watch Materials,
* Opera Glasses

JOBBERS OF ALL GRADES OF
AMERICAN WATCHES.

Gold and Rolled Plated Jewelry.

Selection Packages sent on
Satisfactory Reference.

◁ SEND FOR PRICE LIST. ▷

ESTABLISHED 1837.
GEO. O. STREET & SONS,
MAKERS OF
Fine Rings, Lockets, Seals, Sleeve
Buttons and Links,
5 John Street, - NEW YORK.

HENRY TROEMNER,
No. 710 Market Street, PHILADELPHIA.

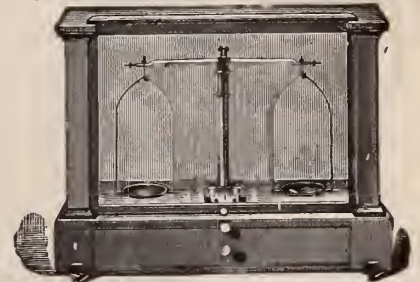

Manufacturer of FINE GOLD SCALES and DIAMOND SCALES
7 Tullion Balances and Weights, in use at all the U. S.
Mints and Assay Offices. Priced Catalogue on application.

Chicago.

There is a good demand for barrel neck chains with screw snaps, and also for men's silver pocket lockets.

Mr. H. D. Sherrill, of Simrock & Sherrill, the well-known manufacturers of the popular "Princess Ring," was quartered at the Palmer last week.

W. H. Beck, of Sioux City, Iowa, spent a few days at the Auditorium recently. Mr. Beck is an enterprising jewelry merchant of the great northwest.

This is only one of a hundred similar hearty and spontaneous greetings, the writer runs across from the jolly and outspoken jewelers of the World's Fair City.

The appearance of THE JEWELERS' CIRCULAR in its new weekly clothes after twenty-one years of usefulness as a monthly called forth much enthusiastic criticism from among the trade.

Mr. Geo. W. Shepardson, the popular western road representative of the Gorham Mfg. Company, returned last week from a short but extremely pleasant trip to New York and Providence.

General Manager and Treasurer Edward Holbrook, of New York, and General Superintendent Geo. Wilkinson, of Providence, of the Gorham Manufacturing Company, were in this city recently.

There seems to be a feeling that "THE CIRCULAR" does is about right. And as a

gentleman said to the writer—"The advent of THE CIRCULAR as a weekly with its conservatism, broad educational tending and general high make up, marks an epoch in jewelers' trade journalism that cannot help but be welcomed."

O. W. Wallis, of the firm of O. W. Wallis & Co., accidentally discovered a few days ago that one of his customers was a member of the regiment of which Mr. Wallis was Major during the war of the Rebellion. Pleasant reminiscences, dating back 30 years, took place, and the two old veterans humorously joked over their many close "shaves."

The writer met Howard Douglas, assignee of the Dueber Watch Case Manufacturing Company, of Cincinnati, and Col. W. A. Moore, of Canton, at the Palmer, Friday last. These gentlemen had run up to Chicago to put on the finishing touches preparatory to raising the assignment of the great movement and case factory.

Under the new dispensation, the New York and Chicago offices will be abandoned and all business will be transacted from Canton. It was toward this cause that the assignee and the Colonel's presence was due in this city.

The "astute" Colonel, who acted as spokesman, said both the factories were running and he had no doubt all difficulties would be at an end by the middle of next week. The bankers of Cincinnati and Cleveland who had delayed negotiations somewhat were now all conciliated and everything

bid fair for a speedy resume of all the machinery of Canton's great industry.

The following Eastern representatives were in town the past week: Fred. Heffron, of Riley, French & Heffron; Geo. Reynolds, of Dutee, Wilcox & Co.; John Keene, of Ostby & Barton; Thos. Fessenden, of Fessenden & Co.; James Underwood, of Champenois & Co.; E. DeF. Wilkinson, of Payton & Kelley; Geo. T. Bynner, of Alvin Mfg. Co.

Lapp & Flersham, of Chicago, dealers in jewelers' supplies, have sent out a series of colored circulars. On one these they call attention to the large increase of business done by them; in another they present excellent cuts of watch cases and movements, and offer to do business in what remains of their stock watches, which they purchased from the Columbus Watch Company. They are closing these out at a low figure and advise their customers to hurry up if they want the goods.

A "bevy" of trade enthusiasts surrounded your correspondent the other afternoon, when the spokesman of the party delivered himself thus: "It's a pleasure to us people in the trade to extend our arms of welcome to THE CIRCULAR and its representation. We feel now that your progressive journal will be liberal in taking care of the Chicago jewelers and will thoroughly recognize the importance and immensity of the business of this important trade center. If you do, and we certainly believe you will, you will find Chicago people the most liberal on the face of the globe."

SIMPSON, HALL, MILLER & CO.

WALLINGFORD, CONN.

MANUFACTURERS OF FINE SILVER PLATED WARE,

Attention is called to their
New Line of



RÉPOUSSE

Superior to anything heretofore
manufactured.

CHICAGO STORE,

141 & 143 STATE STREET,

M. N. BURCHARD,

MANAGER.



MANUFACTURERS OF THE
W^M ROGERS, & C.

WALLINGFORD, CT.

KNIVES, FORKS, SPOONS, & C.

CATALOGUES FURNISHED TO THE TRADE ONLY.

A. G. Perry, one of Giles Bro.'s best men, left on a western trip February 13.

T. W. Duncan, manager of the Elgin Watch Case Company, is in the city. His orders were numerous.

Messrs. H. C. Levett and M. Harshburg, two well-known salesmen, have just gone out on the road for M. C. Eppenstein & Co.

Giles Bros. have a clock in their retail room which is nearly a century old. It keeps excellent time and is much admired by lovers of the antique.

Spaulding & Co., who have been located at the corner of State and Madison streets for nineteen years, will soon remove to more commodious quarters.

H. W. Henshaw, treasurer of the Geneva Optical Company, is in Florida for the benefit of his health. The Geneva company has just received orders from Vienna, Austria, for several of its celebrated lense measures.

Trade continues fair in this city. Many of the retail stores are having special sales of the cheaper grades of jewelry, watches and small diamonds. There is no call for large diamonds and other costly stones. Country jewelers are scarce in the city, most of them sending in their orders by mail. Trinkets, especially those made of oxydized silver, are selling well. Mr. Benj. Allen, of Benj. Allen & Co., said: "Business is fair—a little better than it was last season at this time and better than we expected it would be, considering the financial troubles that occurred in the country last fall."

C. F. Happel & Co., the firm which employs Mr. Wettstein, is one of the old established institutions of Chicago. It was organized in 1858 and opened up for business in Chicago in 1863. Carl F. Happel was the organizer and in 1868, his brother, Frederick, was admitted as a partner. The firm is conservative, and ranks high. It has done a good business right from the start and trade has constantly increased. There have been no ups and downs with C. F. Happel & Co. Wise management, business sagacity and fair dealing have gained them many customers who have always stood by them. For the past eight years the firm has been doing business at Nos. 126 and 128 Dearborn street, but on May 1st they will remove to 88 State street where they have secured a lease of first-class quarters.

A Light for Watches.

A novel electro watch lighter, the tempolux, is being manufactured by a firm of electricians in Leicester, Eng. It resembles an enlarged open-faced watch case, and has in its rim a minute incandescent lamp and reflector. On placing the watch in the case and pressing a small stud, the face of the watch will be brilliantly lighted. A dry battery supplies the current, and may be placed in a closet, with a flexible conducting cord leading from it to the head of the bed or stand on which the watch is placed. The battery will last for this purpose for years, and no chemicals are required.

WIGGERS & FROELICK,
60 NASSAU ST., NEW YORK,
Sample Cases and Trays
For Watches, Jewelry, Optical Goods, Etc.
WE STRIVE TO MAKE THE BEST.

Geneva Optical Co.,
MANUFACTURERS OF
**Spectacles, Eye
Glasses, Lenses
and Cases.**
23 WASHINGTON ST.,
CHICAGO.



BURDON'S SEAMLESS.

THE ORIGINAL
And only Genuine



Perfect Seamless Filled Wires
IN THE WORLD.
Sold to all Manufacturers alike.

Burdon Seamless Wire.
TRADE-MARK.

The success of the BURDON SEAMLESS FILLED WIRE, like that of all important inventions, has been followed by deceptive and imperfect imitations. For the protection of ALL JOBBERS AND RETAILERS, we authorize manufacturers who so desire, to affix upon the tag, card or label accompanying the articles made from this wire, this registered trade-mark owned by this Company. The bird-on-wire is a guarantee that the goods are made from the original Burdon Seamless Filled Wire, the reputation of which has been firmly established among the best dealers for more than two years. The perfection and qualities of the Burdon Seamless Wires are always guaranteed. All Dealers (jobbers and retailers alike) should, therefore, demand goods made from the original Burdon Wire, and avoid imitations which are offered as "just as good."

BURDON SEAMLESS FILLED WIRE CO.,
109 to 119 and 127 Summer Street,
PROVIDENCE, R. I.

OTTO GAS ENGINE WORKS

SCHLEICHER, SCHUMM & CO.
PHILADELPHIA. CHICAGO.

20,000 SOLD.

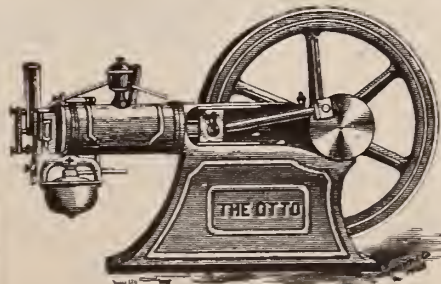

Send for Circular and Reference List relating to this size.

WATCHES.

JOHN B. YATES,

147 NASSAU STREET,
NEW YORK.

SPECIALTY:
UNITED STATES WATCHES

WATCH DIALS.

Any kind watch dial duplicated within ten days. Factories supplied with dials for their entire produce or with special designs for their high grade movements. Special rates for large quantities. Emblems, photographs, landscapes and ornamental work of every description on plain, enamel or under glaze.

WALTHAM DIAL CO.,
WALTHAM, MASS.

THE FINEST **MADE.**

Watch AND Clock Oil

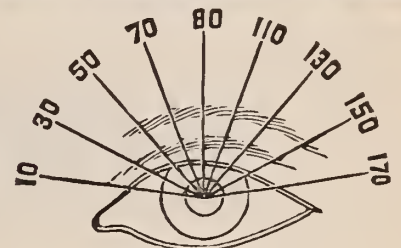

SEND TO
GENEVA OPTICAL CO.

23 Washington St., Chicago,
FOR
PRESCRIPTIONS, REPAIR AND ORDER
WORK PROMPTLY at LOWEST PRICES

GORHAM MFG. CO.

Silversmiths.

SOLID SILVERWARE.

Manufacture and carry in stock the largest assortment of Solid Silver Ware to be found in the country, including specimens of art work of the most elaborate and costly design, as well as articles of plainer and more simple forms suitable for household use.

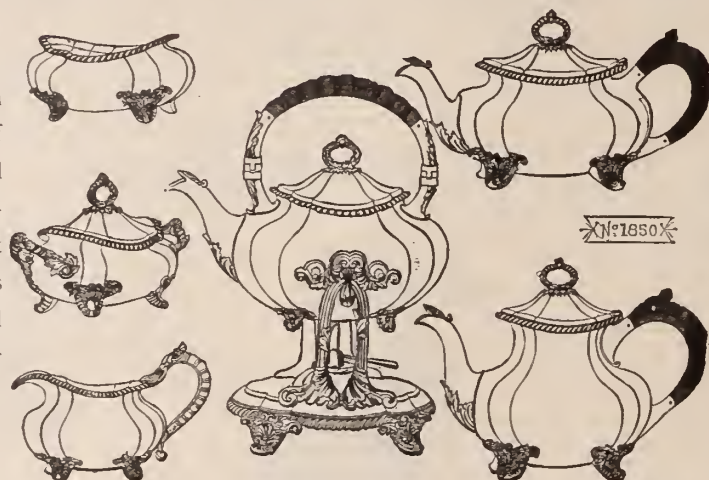

Gorham Mfg. Co.'s Branch Houses:
 9 Maiden Lane, N. Y.
 137 & 139 State St., Chic., Ill.
 120 Sutter St., San Fran., Cal.
 36 Avenue de l'Opera, Paris,
 France.

WORKS: PROVIDENCE, R. I.

ALL COMMUNICATIONS SHOULD BE ADDRESSED,

Broadway and 19th St., New York.

ALFRED H. SMITH & CO.,

DIAMONDS,

182 BROADWAY,

COR. JOHN STREET,

NEW YORK.

33 HOLBORN VIADUCT, LONDON, E. C.

THE JEWELERS' CIRCULAR AND HOROLOGICAL REVIEW.

PUBLISHED EVERY WEDNESDAY BY

THE JEWELERS' CIRCULAR PUB'G CO.,

AT NO. 189 BROADWAY, NEW YORK CITY.

Members of the American Trade Press Association.

A JOURNAL DEVOTED TO THE INTERESTS OF WATCHMAKERS, JEWELERS, SILVERSMITHS, ELECTRO-PLATE MANUFACTURERS AND ALL WHO ARE ENGAGED IN KINDRED BRANCHES OF INDUSTRY.

Terms of Subscription, Postage Prepaid.

	PER ANNUM
United States and Canada, - - -	\$2.00
To all Foreign Countries, - - - -	4.00
Single Copies, - - - - -	.10

ADVERTISEMENT.

Business letters, drafts, checks and post-office orders should be addressed to THE JEWELERS' CIRCULAR PUBLISHING COMPANY, No. 189 Broadway, New York city.

Manuscript from any quarter containing news or discussion of any technical subject within the field covered by THE CIRCULAR will be welcomed. Matter received that proves unsuitable or unavailable will be returned if accompanied by the necessary postage stamps.

Our editorial columns will contain our own opinions only, and we shall present in other columns only what we consider of interest or value to our readers. Applications to print advertising matter as news will not be considered.

Advertising rates in THE CIRCULAR are lower, considering the number of tradesmen reached by its large circulation, than in any other jewelry journal.

Notices of changes in standing advertisements must be received one week in advance, new matter can be received up to Saturday.

VOL. XXII, FEBRUARY 18, 1891. No. 3.

An Interesting Discussion.

WE would call the attention of such of our readers as take interest in horological matters, to a synopsis of two lectures delivered before the Horological Institute of Geneva, treating of the subject of wheels in depths with pinions of low number. The article in question is to be commended, not so much on account of any new points brought forward, as for its completeness and its directions for practical application of the principles enunciated. The subject has been discussed many times by eminent horologists, but never with such clear, comprehensive and exhaustive treatment as in the present instance.

Reconstructed Rubies.

WE publish in this issue an article from *La Nature* on 'The Synthesis of the Ruby.' It will, we are sure, be read with interest by our subscribers.

Although Messrs. Fremy and Verneuil have been very successful thus far in their experiments, and have produced a ruby that is to lay eyes as perfect as the bona fide gem,

they have, as they themselves acknowledge, failed to bring their work to such a degree of perfection as it will be necessary to attain before it can honestly be said that the ruby is an article of manufacture.

It is confessed among the trade that it requires an experienced eye to detect the "reconstructed" rubies; and even when an expert has declared a ruby to be "reconstructed" he cannot prove his assertion by any mechanical or chemical test. Any test the real rubies can endure can also be endured by these bogus gems. Chemical test, the stone, the scales, or any other test will fail to show that they are manufactured.

For American Art Schools.

THE letter of Mr. John Baynas, which is published in another column, and which treats of the subject of art tuition, is composed of new words on an old subject. The study of American art by American students has been agitated, with more or less vigor, for a number of years; yet we seem no nearer the realization of hopes expressed long ago than we were at the time of their expression.

We have among us men, young and old, who have the inherent qualities of designers. For such as these a school, formed of Americans and utilized for the purpose of instructing students in artistic designing, should be formed. Such a school would be a stepping-stone to art in this country, and in time would produce masters who, as Americans, would create a style that, both in design and production, would be distinctively and characteristically American.

American art includes among its branches the designing of articles in jewelry. In some points in this we are in no wise behind our brothers across the water in France or England. But between their work and ours there is this difference. They originate and we copy. Not that we copy implicitly their designs and productions, but that their ideas, which come to this country embodied in brooches, earrings, etc., are taken by our workmen and modified to suit the American taste. France in the matter of diamond settings, seems to economize the gold. England is too lavish with it. Our workmen strike the happy medium that suits Americans. Nevertheless, the foreign ideas and designs are taken almost bodily and changed in the reproduction.

The time has gone by for Americans to plead the "baby act." We are old enough now to take care of ourselves. We have material, from which can be produced some of the best designs in the world. Let some movement be made to use this material.

The Proposed Syndicate.

IN Providence, R. I., the air is full of a proposed scheme for organizing a jewelers' syndicate for export trade with South American countries, Australia, the West Indies and the Sandwich Islands.

There is little doubt that the proposed movement will, if carried to fruition, result in great good to the jewelry trade of the

country, whose goods have at present only a limited market in the countries mentioned.

The condition of pending negotiations with South American countries, leads to the strong hope that trade problems which have long been neglected will soon be solved and reciprocal relations assume a definite shape. It will be some time, perhaps, before the list for reciprocal exchange will include jewelry, but that time will undoubtedly come.

Even if it does not the proposed scheme suggests a plan whereby American merchants may improve the facilities for trade with foreign nations. At present this country is at the mercy of private concerns in other countries, and can ship goods only at the rates they demand. If not only jewelers but other manufacturers as well, would only start a syndicate on the proposed plan of the one spoken of, they might do much toward solving the problem of cheaper shipments of American goods.

Equally important with this, however, is the building of a merchant marine, whose carrying capacity would meet our present and keep pace with our growing needs. Still, one step at a time, and we hope to hear more from Providence after their meeting on the 21st.

Last Week's Arrivals.

L. S. STOWE, Springfield, Mass.; H. Silverthau, New Haven, Conn.; O. E. Curtis, Decatur, Ill., Astor H.; J. J. Coyne, Chicago, Ill., 107 Franklin street.; Wm. Neely, New Haven, Conn., Murray Hill H.; A. R. Justice, Philadelphia, Pa., Metropolitan H.; C. D. Simpson, Scranton, Pa., Normandie H.; M. Cohen, Washington, D. C., Astor H.; A. G. Robbins (Owen, Moore & Co.), Portland, Me., St. James H.; G. S. Pomeroy (Dives, Pomeroy & Stewart), Reading, Pa., Metropolitan H.; Frank D. Day, Duluth, Minn., Park Avenue H.; S. H. Kirby, New Haven, Conn.; S. A. Heiser, Albany, N. Y., St. Stephens H.; L. E. Kirstein, Rochester, N. Y., Union Square H.; J. A. Harwood, Boston, Mass., St. Denis H.

To Set Aside an Assignment.

ON Feb. 13, the actions of Henry E. Oppenheimer & Co. and S. F. Myers & Co. against Morris Herrmann, brought through their attorney G. C. Comstock, were placed on the calendar of the Court of Common Pleas. Each firm brings an individual suit, though for the same purpose. About two years ago Morris Herrmann failed with liabilities of \$8,000 and made a general assignment to William Cohen. About two months ago Assignee Cohen was removed and Daniel A. Warren substituted.

The present actions which were instituted about a year ago seek to set aside the assignment on the ground that it was made to hinder, delay and defraud the creditors, who think that Herrmann disposed of some of the property that should have gone into the transfer to William Cohen.

Charles A. Runk has been appointed referee in the cases. A hearing was set for Saturday last, but nothing was decided.

New York Notes.

(Continued from page 7.)

The New Haven Clock Co., 29 Murray street, are seeking new quarters in the vicinity of Maiden Lane.

Dr. J. Oseroift-Tansley, on February 12, lectured at 36 City Hall Place on "How to Take Care of the Eyes."

A settlement will undoubtedly be effected this week with all the creditors of W. D. Dreher, of Knoxville, Tenn., on the basis of seventy-five per cent.

F. Ayres, who is one of the administrators of the estate of Edward H. Ayres, of Elmira, N. Y., is expected to be in the city in a day or so, for the purpose of settling all accounts standing against the deceased.

L. Sanger, on February 12, secured a judgment against Anthony Hessels for \$3,681.86. This judgment is for an account which accrued before Mr. Hessel's failure some time ago, and in which no settlement has yet been made.

A meeting of the Board of Directors of the New York Jewelers' Board of Trade was held on February 12, at which the following committees were elected for the coming year: Finance Committee, S. F. Myers, August Oppenheimer, and A. J. G. Hodenpyl; the first two were re-elected; Arbitration Committee, John C. Downing, Samuel Aufhausen, David Keller, George E. Fahys, and Henry Dreyfus, all but the last served last year; Membership Committee, Max J. Lisauer, James E. Spencer and Frank R. Simons; the last named is the only new member. H. M. Condit was re-elected secretary and assistant treasurer.

When completed the Jackson Building, now being constructed on the north side of Union Square, New York, will be one of the handsomest and the most perfectly appurtenanced in the city. It is especially designed as an accommodation for manufacturing jewelers. The structure will be eleven stories high, five stories abutting above the adjoining buildings. It will be 28 feet 6 inches wide, and run through from Seventeenth to Eighteenth streets, a distance of 185 feet; it will be entirely fire-proof, and will have a light shaft, 14x25 feet. The beauty of its exterior may be appreciated from an inspection of the front elevation, illustrated on another page. The basement will contain the boilers, engines, and dynamos for the generation of light and power to be furnished the tenants. The gas flues of the building are very wide admitting of a voluminous supply of gas, a point much desired by jewelers. There will be two hydraulic passenger elevators and one freight elevator. The beams are of iron with brick arches between and are thus impervious to fire. The six lower floors adapted to offices, stores and showrooms, while the five abutting stories being completely surrounded by light are adapted to manufacturing purposes. To such as desire it there will be furnished a double flooring which will prove the means of saving a considerable quantity of gold to manufacturers of

jewelry. The building will have every known convenience for the comfort and convenience of the tenants, including iron staircases, mail chute, toilet rooms, etc. Union Square has in the past five years become the center of fine jewelry manufacture in New York, and this building is in the heart of the district. It will be ready for occupancy on May 1. J. Edgar Leaycraft 1,544 Broadway, and Alfred E. Marling, 150 Broadway are the agents.

D. Bernkopf, of Leeder & Bernkopf, Providence, R. I., sailed to Europe last Saturday on *La Gascogne*.

Geo. A. French, buyer for Wm. S. Hedges & Co., sailed to Europe last Wednesday on the *Teutonic*.

The second meeting of the organizing opticians was held on the evening of February 12 at Secretary M. H. Rosenblatt's house at E. Seventy-second street. Among the members present were Messrs. Levison, Miller, Obrig, Stout, Lewen, Dreker, Mayer and Rosenblatt. A constitution and set of by-laws were drafted, and the name of the organization adopted was "The American Association of Opticians". The next meeting was set for February 25th, when the

election of officers will take place and addresses by Messrs. Levison and Lewen will be made.

On Saturday, Feb. 14, the John A. Riley & Sloan Co. was incorporated in Jersey City, under the laws of the State of New Jersey, with a capital stock of \$100,000 all paid in. John A. Riley is president, Frank T. Sloan, son of A. K. Sloan, of Carter, Sloan & Co., is treasurer, and Allan A. MacDonald is secretary. The new company will continue the business of John A. Riley, 860 Broadway, and will manufacture an extensive line of fine gold and silver jewelry. The present factory will be considerably increased. Mr. Riley, who is one of the most fertile-brained designers and ingenious jewelers in the trade, will superintend the general business; Mr. Sloan, who has been for three years in the office of Carter, Sloan & Co., will cover the Eastern and Western trade, and Mr. MacDonald, who for three years has been foreman in Mr. Riley's factory, and who served his time with Durand & Co., and is an excellent practical factory man, will have the general management of the manufacturing department. The company's Newark office is at 289 Washington street.

◆—DIAMONDS—◆

Our Diamond Stock in the future will be separated into twelve grades, as follows:

- A. Blue-White and Perfect.
- B. " " " Imperfect.
- C. Extra White and Perfect.
- D. " " " Imperfect.
1. White and Perfect.
2. " " Slightly Imperfect.
3. " " Imperfect.
4. Very Good Color and Perfect.
5. " " " Slightly Imperfect.
6. " " " Imperfect.
7. Good Color and Perfect.
8. " " " Imperfect.

Copyrighted August 15, 1890.

Copyrighted August 15, 1890.

Each piece in addition to the regular number will have one of above letters or numbers to indicate the quality of the diamond. This will give you the benefit of our judgment as to the grade and quality of each stone, and, we believe, will help you in the purchase and sale of diamonds from our stock.

When in need of anything special in diamonds, send to us for an assortment on selection. Don't hesitate because you may never have had any previous dealings with us, as we should be glad to have you for a customer—and to have you give this new grading system of ours a trial.

J. T. SCOTT & CO.,

4 MAIDEN LANE.



NEW YORK.

Martin Metzger & Co., and Adolph Riesner will move from 5 Maiden Lane.

A. Wittnauer has secured a judgment against Geo. H. and Edmond C. Viemeister for \$147.39.

L. Hammel, of Hammel, Riglander & Co., sailed to Europe last Saturday on the *Eider*, to be gone for an indefinite period.

A pennant of light blue enamel, with the letters "B. C." in silver, has been adopted as the college pin of Barnard college.

Henry Loriot, clockmaker, 89 Nassau St., sailed for Europe on Saturday by the steamer *La Gascogne*, on account of the death of his mother. He says he will inherit \$40,000.

On February 13 word was received in New York of the failure of Brown Bros., large dealers in glass and silver plated ware in Duluth, Minn., with liabilities of \$53,000 and assets of \$67,000.

James Hamblet, superintendent of the horological department of the Western Union Telegraph Co., has returned from his temporary office at 16 Broad street to the Western Union Building, room 48.

James E. Spencer, of the Spencer Optical Mfg. Co., accompanied by his wife and Geo. C. White, of Rogers & Brother, sailed last Saturday on the *Yucatan* to Havana where they will sojourn for three to four weeks.

L. A. Parsons, President of the Brooklyn Watch Case Company and Joseph Fahys, of Joseph Fahys & Co., sailed together to Europe on Wednesday last by the steamer *Teutonic*. They will combine business with rest and will return early in March.

A. E. Wood, for ten years salesman for Simons, Bro. & Co., Philadelphia, has succeeded Col. Thos. W. Manchester in the management of the New York office of J. B. & S. M. Knowles. Col. Manchester is now manager of S. Albro & Co.'s New York office.

A. Wittnauer will on May 1 move from 30 to 19 Maiden Lane, where he will occupy the entire first floor of the building now occupied by Hartley & Graham. His new quarters will be completely renovated, and will be more commodious and convenient than his present ones.

The suit of Wm. S. Hedges & Co. against William H. Payne to recover memorandum goods or their value, about \$1,000, which has been on the Supreme Court calendar for a long time is expected shortly to be called. The attorneys for Hedges & Co. express it as their opinion that Mr. Payne is in business somewhere in this city.

The L. A. Cuppia Manufacturing Company, silversmiths, 42 East Fourteenth street, which has no connection with the old firm of L. A. Cuppia, is having plans drawn for a factory building to be located in Mott Haven, just north of the Harlem River. The company manufactures a regular line of hollow and flat silver ware. L. Fabbriotti is president and treasurer, and Cæsar A. Cuppia general manager. The company has recently opened a showroom at 1 and 3 Union Square.

J. F. FRADLEY & CO.,

Manufacturers of a General Line of

REPOUSSÉ SILVERWARE, MATCH BOXES IN SOLID GOLD AND STIFFENED GOLD, GOLD HEADED CANES, &c.

Office and Salesroom, 23 JOHN STREET,
NEW YORK.

DORFLINGER'S AMERICAN CUT GLASS.



The Finest Crystal, Plain and Cut, made in the World.



EVERYTHING that is
used in Glass, for
the Table.

Sells as well as Silver-
ware.

EVERY FIRST-CLASS JEWELER
C. DORFLINGER & SONS,



BEAUTIFUL, Artistic
and Useful Pieces
for Gifts.

Rivals the Diamond for
Purity and Lustre.

SHOULD KEEP IT.

36 Murray Street, New York.

ASK YOUR JOBBER FOR

The Sun

INTERCHANGEABLE INITIAL RING.

BIPPART & Co.
MANUFACTURERS
OF
Fine Jewelry.
Cor. Marshall & Halsey Sts
Newark, N. J.
LELONG BUILDING
NOVELTIES AND DIAMOND MOUNTINGS

CLASSIFIED INDEX TO ADVERTISEMENTS.

All Advertisements are entitled to one insertion under proper heading. Extra insertions, \$6.00 per Annum. Extra Headings, \$12.00 per Annum.

	PAGE.		PAGE.		PAGE.
Assayers & Refiners.		Gold Chains.		Silver Plated Ware.	
Howard, S. P., 8 John st., N. Y.....	48	Rickert & Stiehle, Newark, N. J.....	14	Rogers & Hamilton Co. The, Waterbury, Conn.....	48
Goldsmith Bros., Chicago, Ill.....	47	Horological Schools.		Pairpoint Mfg. Co., New Bedford, Mass.....	5
Auctioneer.		Waltham School of Horology, Waltham, Mass.....	13	Rogers & Bro., 16 Cortlandt st., N. Y.....	4
French, J. H., Box 2775, N. Y.....	39	Chicago School of Horology, Chicago, Ill.....	33	Rogers, Wm., Mfg. Co., Hartford, Conn.....	45
Black Onyx Jewelry.		Jewelry and Silverware Cases.		Simpson, Hall, Miller & Co., Wallingford, Conn.....	22
Woglom, Gilbert T., 32 John st., N. Y.....	36	Schwarz, N., 866 Broadway, N.Y.....	7	Sterling Silver Jewelry.	
Badges, Medals, etc.		Wiggers & Froelick, 60 Nassau st., N. Y.....	23	Blackinton, R. & Co., North Attleboro, Mass..	39
Stockwell, E. R. 17 John st., N. Y.....	47	Smith, B. & W. B., 220 W. 29th st., N. Y.....	48	Sterling Silver Novelties.	
Books, Stationery, etc.		Jewelry Repairers.		Alvin Mfg. Co., 860 Broadway N. Y.....	36
Dickie, W. B., 67 William st., N. Y.....	46	Wiederhold, A., 20 Maiden Lane, N. Y.....	16	Lewis Bros., 41 Maiden Lane, N. Y.....	7
Chronometers.		Jewelers' Scales.		Sterling Silverware.	
Heinrich, H. H., 14 John st., N. Y.....	13	Troemner, H., 710 Market st., Philadelphia, Pa.	21	Wallace, R. & Sons, Mfg. Co., 3 Park Place, N. Y.....	6
Clock Manufacturers.		Jewelers' Offices.		Durgin, W. B., Concord, N. H.....	43
Schlenker, E. R., Schwenningen on Neckar, Germany.....	46	Jackson Building, Union Square, N. Y.....	20	Gorham Mfg. Co., 19th st. & Broadway N. Y..	24
Waterbury Clock Co., 10 Cortlandt st., N. Y....	38	Jobbers, Watches, Diamonds, etc.		Ludwig, A. & Co., 247 Centre st., N. Y.....	45
Cut Glass.		Bowman & Musser, Lancaster, Pa.....	17	Towle Mfg. Co., Newburyport, Mass.....	41
Dorfinger, C. & Sons, 36 Murray st., N. Y.....	27	Conover, D. F. & Co., Cor. Philadelphia, Pa.	32	Wood & Hughes, 16 John st., N. Y.....	46
Diamond & Precious Stone Importers.		Hennege, Bates & Co., Baltimore, Md.....	15	Shiebler, Geo. W., 6 Liberty st., N. Y.....	42
Hedges Wm. S. & Co., 170 Broadway, N. Y....	43	Katlinsky & Gatzert, 96 State st., Chicago, Ill.	34	Fradley, J. F. & Co., 23 John st., N. Y.....	27
Kahn, L. & M. & Co., 10 Maiden Lane, N. Y.	48	Koch & Dreyfus, 22 John st., N. Y.....	42	Mauser, Frank & Co., 30 Union Square, N. Y..	47
Kipling, E. E., 2 John st., N. Y.....	48	Myers, S. F. & Co., 48 Maiden Lane, N. Y.....	43	Tool Manufacturers.	
Oppenheimer Bros., & Veith, 35 Maiden Lane, N. Y.....	11	Yates, John B., 147 Nassau st., N. Y.....	23	American Watch Tool Co., Waltham, Mass....	16
Randel, Baremore & Billings, 29 Maiden Lane, N. Y.....	11	Cross & Beguelin, 21 Maiden Lane, N. Y.....	21	Chicago Watch Tool Co., Chicago, Ill.....	33
Smith, Alfred H. & Co., 182 Broadway, N. Y....	24	Scott, J. T. & Co., 4 Maiden Lane, N. Y.....	26	Waltham Watch Tool Co., Springfield, Mass..	31
Kipling, R. A. 31 Union Square, N. Y.....	21	Beguelin, Tell A., 71 Nassau st., N. Y.....	18	Typewriters.	
Fera, Henry, 10 Maiden Lane, N. Y.....	43	Friedlander, R. & L., 65 Nassau st., N. Y....	41	Wyckoff, Seamens & Benedict, Broadway, N.Y.	16
Peterson & Royce, 189 Broadway, N. Y.....	16a	Swartchild & Co., Chicago, Ill.....	12	Watch Companies.	
Diamond Cutters.		Musical Boxes.		Non-Magnetic Watch Co., 177 Broadway, N. Y.	16
Groeneman, A. J. & Co., 80 Nassau st., N. Y....	7	Jacot & Son, 298 Broadway, New York.....	46	Stop.....	33
Diamond Jewelry.		Optical Goods.		Trenton Watch Co., Trenton, N. J.....	9
Falkenau, Oppenheimer & Co., 40 Maiden Lane, N. Y.....	48	Geneva Optical Co., 23 Washington st., Chicago, Ill.....	21, 23, 33	Watch & Clock Oils	
Ludwig, Nissen, & Co., 18 John st., N. Y.....	12	Zineman, M. & Bro., Philadelphia, Pa.....	15	Nye, William F., New Bedford, Mass.....	23
Stern Bros., 42 Maiden Lane, N. Y.....	41	Order Work.		Watch Keys.	
Sexton Bros. & Washburn, 41 Maiden Lane, N. Y.....	13	Maxheimer & Beresford, 3 Maiden Lane, N. Y.	7	Clark, A. M., Plainville, Conn.....	35
Engravers and Designers.		Pens, Pencil Cases, Etc.		Kendrick & Davis, Lebanon, N. H.....	49
Bartholomew & Peckham, 18 Spruce st., N. Y.	46	Aikin, Lambert & Co., 23 Maiden Lane, N. Y.	37	Watch & Clock Dials.	
Ryder & Dearth, 146 Westminster st., Providence, R. I.....	12	Ring Makers.		Waltham Dial Co., Waltham, Mass.....	23
Eye Glass Holders & Chains.		Bowden, J. B. & Co., 192 Broadway, N. Y....	33	Watch Case Manufacturers.	
Merritt, S. F., Springfield, Mass.....	36	Bryant, M. B. & Co., 10 Maiden Lane, N. Y.	7	Brooklyn Watch Case Co., 192 Broadway, N.Y.	45
Fancy Goods, Bric-a-Brac, Etc.		Haskell, H. C., 192 Broadway, N. Y.....	38	Courvoisier, Wilcox Mfg. Co.....	35
Taylor & Bro., 860 Broadway, N. Y.....	48	Hildreth Mfg. Co., 51 Maiden Lane, N. Y.....	18	Feinier, G. F., 9 Bond st., N. Y.....	34
Gas Engines.		Ostby & Barton, 80 Clifford st., Providence, R. I.....	12	Essex Watch Case Co., Newark, N. J.....	42
Schleicher, Schumm & Co., Philadelphia, Pa....	23	Wodiska, Julius & Co., 49 Maiden Lane, N. Y.	27	Roy Watch Case Co., 17 Maiden Lane, N. Y.	31
Gold Jewelry.		Rolled Plate Chains.		Muhl's Sons, H., 629 Chestnut st., Philadelphia, Pa.....	19
Bippart & Co., Newark, N. J.....	27	Cheever, J. G. & Co., No. Attleboro, Mass....	46	Jeannot & Shiebler, 20 Maiden Lane, N. Y....	42
Carter, Sloan & Co., 15 Maiden Lane, N. Y....	37	Kent & Stanley, 7 Eddy st., Providence, R. I....	3	Wadsworth, H. A. & Co., Newport, Ky.....	10
Cottle, S. Co., 860 Broadway, N. Y.....	46	Rolled Plate Jewelry.		Watch Case Repairers.	
Jonas, Dorst & Co., Race street, Cincinnati, O.	41	Foster & Bailey, 60 Richmond st., Providence, R. I.....	2	Henry, Peter, Cincinnati, O.....	34
Larter, Elcox & Co., 41 Maiden Lane, N. Y....	11	R. I.....	2	Watch Importers.	
Riley, John A., 860 Broadway, N. Y.....	34	Plainville Stock Co., Plainville, Mass. .	46	Witnauer, A., 30 Maiden Lane, N. Y.....	7
White, W. E. & Co., 54 Page st., Providence, R. I.....	42	Ludwig, H. & Co., Providence, R. I..	46	Mathey Bros., Mathez & Co., 14 Maiden Lane, N. Y.....	39
Krementsz & Co., 182 Broadway N. Y.....	31	Seamless Wire.		Abry, Chas. L., 41 Maiden Lane, N. Y.....	36
Moore & Horton, 11 Maiden Lane, N. Y.....	43	Burdon Seamless Filled Wire Co., Providence, R. I.....	23	Watch Materials, &c.	
Owen, G. & S. & Co., 3 Maiden Lane, N. Y....	43	Settings & Galleries.		Cross & Beguelin, 21 Maiden Lane, N. Y.....	21
Street, Geo. O. & Sons, 15 John st., N. Y.....	21	Blancard & Co., 36 John st., N. Y.....	34	Keller, L. H. & Co., 64 Nassau st., N. Y.....	13
		Silk Guards.		Friedlander, R. & L., 65 Nassau st., N. Y.....	41
		Rosentall, Wm., 79 Nassau st., N. Y.....	34	Welded Steel.	
				Chrome Steel Works, Brooklyn, N. Y.....	34
				Watch Repairers.	
				Simmonds, J. C., 18 John st., N. Y.....	37

Special Notices.

Rates 75c. per insertion for notices, not exceeding 3 lines; additional words 2 cents each. If answers are to be forwarded, postage stamps must be enclosed. Two insertions, 10 per cent. off; three insertions, 15 per cent. off; four insertions, 25 per cent. off. Payable strictly in advance.

Situations Wanted.

THE JEWELERS' CIRCULAR has a guaranteed circulation of over 10,000 copies weekly. It is, therefore, the best medium for reaching the trade. To demonstrate this to advertisers, notices in this column will be inserted free of charge during the month of February.

WANTED.—Situation by a watchmaker of 15 years, experience; full set of tools, and best references furnished; North or West preferred. Address, C. A. S. Edgett, 45 East Mitchell street, Atlanta, Ga.

A RETAIL JEWELER of experience desires a position as traveling salesman. Best of reference or bond, if necessary, to responsible house. Address, Lock box 16, Boyden, Iowa.

ACCOUNTANT, partially disengaged, would write up, examine or keep a set of books. Highest reference; terms moderate. Address, Expert, P. O. Box 2456, New York.

WANTED.—Position by young man; with five years' experience in watch, clock and jewelry repairing. A 1 references. Address, Watchmaker, Box 102, Charles City, Iowa.

A YOUNG MAN, about 24 years old, with four years' experience in the jewelry business, would like a position paying about \$15 a week. Excellent habits; is a good salesman, watch maker, repairer and plain letter engraver. Address: Lock Box, 944, Lyons, Wayne Co., N. Y.

WANTED.—By a single man of about 30, with nineteen years' experience in the trade, a position as first-class watchmaker and repairer. Is familiar with the use of the lathe. Address, John Scherer, care THE JEWELERS' CIRCULAR.

YOUNG MAN with six years' experience, who understands watch and clock work, when not complicated, would like a position with a first-class watchmaker, to finish learning the trade. Is temperate, honest and industrious, and has all necessary tools except American lathe. Best reference; moderate salary expected at first. Address Jas. H. Grubb, Clearville, Pa.

YOUNG MAN who understands hard soldering and can do clock-work and watch-work when not complicated, would like to get a position with a first class watchmaker and finish trade. Temperate, honest, industrious and does not use tobacco. Expects a reasonable salary to commence. Have good mechanical ideas. Some tools. Address, F. E. Hackett, Box 476, Baton Rouge, La.

POSITION WANTED.—By an experienced and A 1 traveling salesman; good references given. Address H. F., care THE JEWELERS' CIRCULAR.

WANTED.—Position by a first class watchmaker, clockmaker, jeweler, and repairer of musical toys, etc. Can put my hands to any variety of repairing work. Have had thirty years' experience; can furnish best of references and security if desired. Would prefer a position in New York City or near-by town. Address, D. H. J., care THE JEWELERS' CIRCULAR.

WANTED.—Situation as traveling salesman with reliable manufacturing or jobbing firm. Will carry any line connected with the jewelry business. Good reference, no bad habits, and a hard worker. Seventeen years in the retail business. Address, C. L. James, 17 14th street, Toledo, O.

WANTED.—By a young man of 23, position as assistant watchmaker under finished workman, where I can be instructed on difficult and complicated work. Have had between 2 and 3 years' experience; am strictly temperate, and can give best of reference. Address "L," 224 Main street, Middletown, Conn.

WANTED.—By a single man, 26 years of age, a position in a wholesale jewelry or diamond importing house, as salesman in office or to travel. Have had five years' experience in a retail jewelry store. Highest references given. Address, V. Z., care JEWELERS' CIRCULAR.

WANTED.—Position by a young man 28 years of age. Has had five years' practical experience in the retail optical business, being able to do all kinds of repairing usually done in an optical store. Can set all kinds of cylinder and compound lenses into both specs and eye-glasses. Have also had two years' experience in fitting ordinary cases of defective eyesight. Would like a position in some established optical house or manufacturing optician. Address K. W. M., care JEWELERS' CIRCULAR.

Help Wanted

WANTED.—A first-class watchmaker and engraver. State age, experience, salary expected. Can give to right party a desirable position. Address, Theo. L. Rogg, Des Moines, Ia.

WANTED.—A first class traveler. One acquainted with Texas trade preferred; good salary. Address, Koch & Dreyfus, 22 John street, New York.

WANTED.—A thoroughly competent watchmaker and jewelry repairer in New England city; must have tools and experience, and be well recommended; state age, experience, and salary desired. Address Good Opportunity, care JEWELERS' CIRCULAR.

A YOUNG MAN familiar with silver plated ware, and jewelry repairer in New England city; full of push as junior salesman. Address with full particulars giving experience. References, salary expected, etc., Address B. R., Box 320, N. Y. P. O.

WANTED.—A few traveling men who are practical watchmakers, and have the time—to call the attention of the craft to the Mosely Lathe and Attachments, through the East and Southwest. Address, Mosely & Co., Elgin, Ill.

WANTED.—Experienced traveling salesman. Address, Oskamp, Nolting & Co., Cincinnati, Ohio.

Business Opportunities.

FOR SALE.—In one of the most rapidly growing manufacturing towns in Pennsylvania. Fine new stock of watches, clocks, jewelry material and fixtures. Trade well established and growing, plenty of bench work. Low rent. Practically no opposition. Will invoice about \$6,500. Stock can be reduced, good reasons for selling. Address, Pennsylvania, care THE JEWELERS' CIRCULAR.

THE handsome jewelry and optical business of E. P. Langston at Easton, Md. Stock and fixtures about \$8,000.

A established jewelry business, for sale; excellent location in suburban city; good opening for a practical watchmaker, will sell cheap for satisfactory reasons. Easy terms to good man. Address, C., care of JEWELERS' CIRCULAR.

For Sale.

FOR SALE.—1½ Whitcomb Lathe, Webster wheel, universal head slide rest, Beach & Snyder chuck, and a full line of split wire chucks, counter shaft, etc. Will be sold cheap. B. H. Cosby, jeweler, Asheville, N. C.

FOR SALE.—A Mosely No. 1, soft lathe with ten chucks, countershaft, footwheel and universal face plate all nearly new. Also one standard lathe cheap. Wanted to buy, or will trade the above for a No. 3, hard American lathe or a watch factory machinist's bench lathe. Address Box 1407, Rockford, Ill.

A FINE ship chronometer for sale cheap. Address: A. C. Taylor, Cedar Rapids, Iowa.

FOR SALE.—One Swiss universal lathe, geared, and attachments. Good as new. Price \$10. Address: J. Coatsworth & Son, Galena, Ill.

FOR SALE.—One James Bottom lathe with stand, foot wheel and all attachments. Price complete \$15. Address: J. Coatsworth & Son, Galena, Ill.

To Let.

TO MANUFACTURING JEWELERS AND OTHERS.—A floor to let in the new improved factory building, corner St. Marks and Underhill avenues, Brooklyn. Fine light, power and all modern improvements; within twenty minutes of the Brooklyn ferries. Apply to Geo. W. Shiebler, 8 Liberty Place, New York City.

WORK SHOPS to let in the large, new fire-proof building 29 and 31 Gold street, near John street, New York. Excellent light, steam heat, fire-proof vaults, solid floors, elevator, power in abundance: Apply to Chas. S. Piatt, 31 Gold street.

Miscellaneous.

W. A. SCHROETER, 108 Grand street, New York City. Estimates rendered on any desired job. Four expert watch repairers employed specially for Trade Work. Guaranteed finely finished at low prices. Also a good chance for a young man to study watchmaking.

W. F. A. WOODCOCK'S SCHOOL FOR WATCHMAKERS, Winona, Minn., offers unrivaled facilities for acquiring a thorough practical knowledge of every branch of the business. Terms very reasonable.

Norfolk.

The auction sale at Freeman's of jewelry goods continues to draw crowds daily.

The Jewelry Palace received and opened last week the handsomest line of quadruple silver-plated ware ever shown in this city.

The fancy store recently opened here by F. L. Woolworth & Co., of Boston, has a separate department for the sale of cheap jewelry.

C. F. Greenwood & Bro. have been made agents for this city for the watch manufacturing firm of Patek, Phillipe & Co., Geneva, Switzerland.

Arthur C. Freeman, the Main street jeweler, recently represented Governor McKinney, of Virginia, at the Old Guard's Ball given in New York City.

Henry Carter, of New York, and Mr. Simmons, of Simmons Bros., Philadelphia, are in Norfolk in the interest of their respective firms.

Mr. Chapman, of the firm of Chapman & Gale, states that business has been better by fifty per cent. in the period since the holidays than it has been since their opening twenty-five years ago.

Arthur Hirsh, representing Henry May, of New York City, registered at the Atlantic Hotel this week. Mr. Hirsh will make an extended drumming tour of the Southern States before returning to New York.

A. J. Savage, doing business at 88 Main street, makes a speciality of melting Mexican silver into tea and table spoons, forks, etc. These goods are warranted solid without plating, and will not tarnish. There is a great demand for them here.

H. B. Laskey, who has jewelry establishments in New York and Washington, D. C., has opened another store at No. 101 Salena avenue, Roanoke, Virginia. The opening took place on Monday, February 9th. A beautiful souvenir was given to each customer. One of the features of Mr. Laskey's establishment is marking prices in plain figures.

The following traveling salesmen have been in Norfolk during the past week: George Peacock, representing Kellar, Eddinger & Fink, New York City; Ben Lyons, with S. Kind & Co., Philadelphia; Eli Bloomberg, with S. M. Stern & Co., Philadelphia; Mr. Ettinger, with Kellar & Untermeyer, New York; George B. Cohen, of Philadelphia; Mr. Goeddel, with J. Rosenstock & Co., Baltimore, Md.; Mr. Prespritch, of Wm. Tonk & Bro., New York; Col. Jackson, of Miller Bros., New York; N. D. Moldo, representing The New Haven Clock Co., New Haven, Conn.; Wm. E. Cohen, with David Marx, New York; A. J. Hartogensis, of Hartogensis & Co., Balto., Md.; I. Oppenheimer, of M. Friedberg, New York; Mr. Davidson, with V. Dairdow, diamond dealers, Philadelphia, Pa.

Boston.

George H. Griffin, of Portland, Me., was in town this week buying goods.

E. Wiener, formerly with H. Weber & Co., has accepted a position with Henry Cowan.

The year 1891 has as yet brought out no striking and popular novelty. The old fads reign supreme.

Mr. Southworth, of D. C. Percival & Co., has returned from a flying trip to New York and Philadelphia.

A. H. Potter & Co. are to remove from 421 Washington street to a larger and more commodious store under the Adams House.

Among the boys in blue who attended the recent Grand Army encampment in Boston, was J. A. Rawson, the Amherst, Mass., jeweler.

Charles F. Morrill, Irving Smith and J. S. Blake form the committee of arrangements for the coming ladies' night annual banquet of the Jewelers' Club.

Grimes is also one of our oldest subscribers to THE CIRCULAR and in another recent communication says THE CIRCULAR is the best trade paper now published."

The Boston office of Kent & Stanley, manufacturers of the well-known "Seamless" chains, will hereafter be in charge of I. W. Stelle who will also look after the near-by trade.

Robert Pearson, a Boston artist of much merit, died in Malden recently. He and his twin brother, William Pearson, constructed and exhibited a model of the Strasburg clock, which proved a financial success.

Henry Cowan has added to his business the manufacture of silk cord for bead necklaces. The Waltham Watch Tool Company, of Springfield, Mass., has entered into an arrangement with Mr. Cowan also, by which he becomes their New England agent.

O. C. Dow, who formerly made his headquarters at E. A. Cowan & Co.'s has taken a room next to the office of the American Watch Company, at 403 Washington street, where he will have a line of American materials and tools. His specialty is the Rivett lathe, made by the Faneuil Watch Tool Company, of Faneuil, Mass., in which he is a large shareholder.

Some practical electricians are confident that electricity can be successfully employed in the process of soldering jewelry, much cheaper than it can be done by gas. With that idea in view, a great deal of quiet experimenting has been done, with, it is said, satisfactory results. Should its practicability be demonstrated, it will add another to the elements of warfare between the two systems—gas and electricity—which is already decidedly warm here.

The Boston Jewelers' Club held its annual business meeting February 10th at the Boston Tavern, and an informal lunch followed. The officers elected are: President, David C. Percival, of D. C. Percival & Co.; vice-president, Irving Smith, of Morrill Bros. & Co.; secretary and treasurer, James S. Blake of Kettell & Blake; executive committee, D. C.

Percival, J. S. Blake and Charles F. Morrill, president of the Bay State Watch Case Company. E. Frank Wilson, who has recently started in the jobbing trade, was admitted to membership.

Among the traveling men in town this week were E. W. Martin, of Martin, Copeland & Co., Providence; Mr. Untermeyer, of Keller & Untermeyer, New York; George L. Vose, of Providence; Frank Sherry, of Joseph Fahys & Co., New York; F. E. Parsons, treasurer of the Brooklyn Watch Case Company; Frank Woods, Carter, Sloan & Co., New York; Mr. Taylor, Krementz & Co., New York; Mr. Bell, B. S. Freeman & Co.; Mr. Mauran, of T. T. Mauran & Co.

Charles T. Seaverns & Co., the diamond merchants at 403 Washington street, who were petitioned into insolvency by Sanford & Cook, of New York, have filed their schedules. The assets are jewelry and precious stones in possession of the Fourth National Bank, of this city, as collateral to secure about \$30,000, valued at \$78,500; diamonds in possession of the Collateral Loan Company, to secure \$650, valued at \$1,500, store fixtures, valued at \$300. There are bills receivable for \$25,000, estimated of no value. The liabilities are claims of E. August Neresheimer, \$10,444.52; Henry Dreyfus & Co., \$3,441.61; Fourth National Bank, \$55,358.70; Peterson & Royce, \$7,073.29; Sanford & Cook, \$5,861.25; small claims aggregating \$14,602.68. The individual assets and liabilities are submitted. Charles T. Seaverns owes \$57 with no assets; John Vose's liabilities are \$555.44, no assets; Henry T. Seaverns has outstanding notes for \$28,000, and balance of partnership account to Lincoln Morrison, \$6,078.80, with liabilities represented by land in Brookline, held in trust by John Gibbs, and valued at \$15,000.

Lancaster, Pa.

Arthur Bradshaw, of the Meriden Britannia Company, was in the city recently. He had already covered the western part of his territory and reported very good trade.

Jack L. Straub, the well-known jeweler of Cumberland street, Lebanon, and Miss Annie F. Eckert, of the same city, came to Lancaster on Monday last and were married by Rev. Hutslers. They returned to their home on the evening train.

Bowman & Musser, the well-known jobbers of this city, have three traveling men on the road at present. Mr. Edward W. Drury covers Pennsylvania, Baltimore and Washington; Mr. Henry Ansley, the material man, covers the Middle States, and Mr. A. W. Moyer, the countries adjacent to Lancaster.

Wilson H. Appel, the prominent jeweler of Allentown, was married Thursday afternoon to Miss Elizabeth S. Kauffman, of Lititz, this county. The ceremony took place at the bride's home, Rev. C. L. Moench, of the Moravian church, officiating. They left on the evening train for Allentown, where a furnished home awaited them.

Lewis Weber, jeweler of this city has just overhauled for Squire A. R. Witmer a

crescent and star of diamonds, and solid thread mounting. On the reverse is a raised monogram of three letters, "W. H. F." in diamonds, rubies and sapphires. The locket contains in all sixty-eight stones.

Among the traveling men in town during past week were Harry Retzlaw, with M. Adler, diamond importer, New York; Isaac Rubenstein, of Maiden Lane, New York; Rodney Pierce, with the Julius King Optical Company, Cleveland, Ohio; F. Van Olinda, with the Wm. L. Gilbert Clock Company, Murray street, New York; F. Skillman, of Skillman, Vanderveer & Williams, Trenton, N. J.

large family clock which he procured from his grandfather. It was built by Christian Eby, of Manheim, this county, over a hundred years ago and is in as good condition as when new. It has second, minute, hour and month hands, shows the phases of the moon and runs thirty-two days.

Ernest Zahn, manufacturing jeweler of this city, has just turned out for the trade a gentleman's locket of unusually handsome and unique design. On one side are a raised

Not For Commercial Purposes.

A STORY that seems to indicate that Canada's medal making jewelers are protected to the last notch is told by one of the interested parties, as follows: "Some time ago one F. C. Swaab, of Brussels, Germany, wrote us that if five of our members would take copies of his Rembrandt medal, which represented on one side the famous artist, and on the other a design of his famous picture "Rond de Nuit," we could have them for five dollars each, payable C. O. D. The number was made up, one of the subscribers being a leading Judge of this city. In due course the medals arrived in separate wrappers in this country but were detained by the customs. Each of the subscribers was asked to pay a duty of thirty per cent. or \$1.50 on each medal. This was unheard of. I have imported medals for my collection for years and have had no duties to pay. Up to about three years ago all medals were admitted free. Then in consequence of a development in the medal-making trade of some Canadian jewelers a duty was put on medals imported for commercial purposes, to be sold, given in schools, etc., but medals imported for collections were still listed free. Well, when we pointed out that these medals were for individual collections, the matter was referred to the custom authorities at Ottawa, the Dominion capital. A long delay ensued. No answer. The Judge wrote. No answer. And so at last we have all decided to let the medals go back to their starting point, sooner than pay a duty like that.

An Odd Scarf Pin.

A curious scarf pin, worn by a Nashville man, is a petrified human eye, set in a gold frame. The present owner of this singular ornament found it in Peru while he was on an exploring tour in the land of the Incas with a party of scientists.

Correspondence

To the Editor of the *Jewelers' Circular* :

NEW YORK, Feb. 14, '91.

DEAR SIR:—My attention has been directed to a movement now on foot for aiding American art students. It is not my desire to write a single word calculated to interfere with the commendable intentions of the gentlemen who have originated the movement, but I do desire to point out the absolute inadequacy of the scheme (so far as yet outlined) to meet even partially the needs of American art students.

In the *Tribune* there was an article of something more than a column's length under the caption "Mr. Chandler's Art Scheme." In this article Mr. Chandler is quoted as saying that "the object of the art scheme is to raise money enough to send art students abroad to study painting and decorating." He says further that "every dollar put into this thing will return 100 cents in the benefit given to local art. With the \$25,000 subscribed in New York, five years from next September this city will have an artist with the best Parisian teaching in painting, drawing and composition, thoroughly in touch with the latest views on art in Paris."

Now I will leave all considerations which apply to painting to those who are competent to deal with them, and will confine myself to that part of the scheme which applies to "decorating" for the reason that this is my profession and that the exercise of it brings me in daily contact with American-born designers and art students, and furnishes opportunity for understanding their needs and possibly pointing out a remedy for them.

First, a word concerning this Paris scheme. If it be desired that American decorative art shall be a National art, the offspring of suggestions native to American soil, is Paris the place in which to learn it? Are the sweet marvels of Japanese art the outcome of instruction imported from Paris? The best designers who ever lived never saw or even heard of Paris.

The art which it should be the business of the American art students to become masters of, should be inspired by love of nature, by her meaning and teaching, by the forms and colors which she wears beneath his native skies.

An art with the odor of fresh soil, of wild flowers, of the pine forest and the prairie, of the maple and the brave old hickory tree. American national art is not taught in Paris, never will be; and it never can be taught there or any where else than in America.

The editor is aware that there is in this city an institution known as the N. Y. Institute for Artist-Artizans and which is under the management of Mr. Stimson, aided by such thorough Americans as Mr. William Hamilton Gibson, etc. The purpose of this institution is to instruct students in the fundamental principles of all good art and to stimulate and aid in the development of American art in particular, to develop individuality and home taste and to exclude fads, mannerisms and monkey imitations of foreign fancies.

S. H. Vedder, the American pupil to whom three medals were recently awarded by the Beaux Art School in Paris, was a pupil of Mr. Stimson's, as were also the two boys who won the first and second prizes for "Illustrations" at a recent public contest in this city.

A corporation in which I am interested has in its employment several designers, all native-born Americans, three of these pupils from Mr. Stimson's school, and after a varied experience with designers of other nationalities we prefer them to any other because they are more free from prejudices, more inventive and because they possess sweeter fancies.

Mr. Stimson is fighting for a principle and his fight has been and is a hard up-hill one. He has been aided by some firms interested in art industries and by other public-spirited citizens interested in American art. Mr. Stimson has made many sacrifices and has contributed from his own means to the extent of his ability.

If those who are interested in promoting the advancement of American art built upon a National foundation will come to the aid of this man, relieve him from some of his burdens and help him to extend his facilities and increase his equipment; if, in addition to this a real art library could be established and arrangements made for the more frequent exhibition of private collections of works of art and for some extension of public museum service; if, I say, this could be accomplished, more service would be rendered to the Students of decorative art in the City of New York than could be accomplished by sending a few prize winners to Paris, or by presenting to them "five years from next September" a gentleman "thoroughly in touch with the latest views on art in Paris."

I am, sir,

Yours truly,

John Baynes,
President, Tracery & Mosaic Co.,
603 West 36th Street,
New York.

Aurora.

The annual meeting of the Aurora, Ill., Silver Plate Company was held on February 10, and over \$90,000 of the stock was represented. Wm. Le Baron, of Chicago, was made chairman of the meeting, and F. B. Rice, of Aurora, secretary. Manager Rice, read his annual report, which showed that 1890 was one of the most prosperous years in the history of the company. The old Board of Directors, J. G. Stolp, Horace Gilbert, John Reising, F. B. Rice, O. M. Shedd, W. F. Dickenson and G. W. Quereau was unanimously re-elected. A vote of thanks was tendered the directors and the manager for the efficient manner in which the affairs of the company had been conducted.

HEADQUARTERS FOR

14-K. BEAD NECKLACES,

GOLD JEWELRY,

— AND —

Krementz One-Piece Collar Buttons.

KREMENTZ & Co.,

MANUFACTURERS,

182 & 184 Broadway, NEW YORK.



WE CONSIDER

THE "HOPKINS" LATHE

THE BEST LATHE MADE.

Some may think us somewhat prejudiced because we are the makers of these splendid tools, we therefore append a sample of the many words of voluntary commendation we are receiving from those who use our tools, and speak from knowledge born of experience:



ABITA SPRINGS, LA., FEBRUARY 3, 1891.

GENTLEMEN:—I am more than well pleased with the lathe you sent me and would not exchange for any other lathe in the world.

Yours truly,

M. GREEN.

The above was one of our 3 X 4 HARD LATHES which are giving such universal satisfaction.

SEND FOR OUR COMPLETE ILLUSTRATED CATALOGUE.

WALTHAM WATCH TOOL CO.,

SPRINGFIELD, MASS.

FIGURES TALK.

6,000 PAIRS DAILY of Spectacles and Eye Glasses are sent out by the

SPENCER OPTICAL MFG. CO.

MAKING A GRAND TOTAL OF

1,800,000 PAIRS ANNUALLY.



The reason is that the trade are realizing that it is to their advantage to deal directly with the manufacturers. We advertise no cut prices. All our prices are lower or as low as the lowest, when quality is considered. Our Catalogues and Price-List are free.

OPERA GLASSES

Of new designs and styles are already being prepared for the fall trade of 1891. Send in your orders and have name engraved on eye-piece. Our

OPERA GLASS HOLDERS

Are a great success, and customers are sending holders of other makes to be exchanged for our improved "grip."

A HARD CASE

To excel is the "Audemair" Oculists' Trial Case. 15 styles at 15 prices; from \$36.00 to \$100.00. You should see it before purchasing.

ANYTHING PERTAINING TO VISION

Can be obtained of us.

THE SPENCER OPTICAL MFG. COMPANY,

15 MAIDEN LANE, N. Y.

MANUFACTURING OPTICIANS.

FOR CLEANING AND POLISHING.

THE LATEST AND THE BEST

POLISH

FOR

SILVER GOLD, NICKEL

AND GLASS.



WILL NOT SCRATCH

THE

FINEST SURFACE.

EVERY RETAILER OUGHT TO HAVE IT IN STOCK.

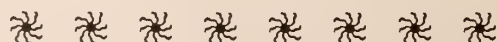

DAVID F. CONOVER & CO.

PHILADELPHIA, - - - - - PENN.

BEING convinced that after a fair trial you will find it to your advantage to take

The Jewelers' Circular

regularly, we offer the following inducements to new subscribers:

UPON RECEIPT OF TWO DOLLARS

(the price of one year's subscription), we will send THE CIRCULAR for one year (52 numbers) to any address, and a copy of our book of **Monogram Plates**, which contains **44 Plates** or **2,112 Monograms** in all, in six different styles. Or for

50 CENTS, WE WILL SEND

The Jewelers' Circular

For **SIX MONTHS** on trial.

Either of the blanks given below, if filled out and returned with the proper amount of money, will secure for you one of the best trade journals in the world for the time stated.

189

TO THE **Jewelers' Circular Publishing Co.,**
189 BROADWAY, NEW YORK.

Enclosed please find **TWO DOLLARS**,
for which send **THE JEWELERS' CIRCULAR**
for One Year, beginning _____
and one book of *Monogram Plates*.

NAME, _____

ADDRESS, _____

189

TO THE **Jewelers' Circular Publishing Co.,**
189 BROADWAY, NEW YORK.

Enclosed find **FIFTY CENTS**, for which
send **THE JEWELERS' CIRCULAR** for **SIX**
MONTHS, on Trial, beginning _____

NAME, _____

ADDRESS, _____

New Haven.

Jeweler A. D. White, of this city, is still very ill at his home.

The Simpson, Hall, Miller & Co., manufactory in Wallingford is now working full time.

Charles Leyrszapf, jeweler, of this city, sailed for Europe this week, to be absent six months.

The Derby Silver Company's works are again in operation and working full time. Steam power now runs the machinery.

Official returns show Rogers Silver Plate Co., Danbury, capital, \$25,000, real estate \$4,000, personal estate \$28,595.20 debts \$23,781.52, credits \$14,653.10.

Silver Plate Company's works in Shelton are also now running again. They also now have steam power. Meanwhile a big force of men and skilled engineers are at work to repair the broken dam of the Housatonic River.

The Cheshire Watch Company officially announces in some of the Connecticut papers its reduction of its capital stock from \$200,000 to \$100,000. Its directors are E. R. Brown, T. Guilford, Samuel E. Elmore, F. F. Street, G. J. Capewell.

Secretary Morgan, of the New Haven Clock Company, was one of the prominent men at the auction sale of the Cheshire Clock Company. He bought extensively of the machinery offered. His purchases were not for the New Haven Clock Company.

D. B. Hills, clock manufacturer in Plainville, Mass., has bought the Hubbell clock factory in Forestville. Mr. Hills has become the owner of a valuable plant for the making of clock movements, including much valuable machinery and many tools, as well as a good water privilege.

A dead-beat named Rothschild is peddling the cheapest kind of window-glass spectacles and eye-glasses around Litchfield county, Mass., for which he charges \$5.13 each and leaves \$2 on account to be sent to his house after trial of the glasses. They probably cost him wholesale thirteen cents apiece; his profit is, therefore, \$1 on each sale, as he never expects to get the other \$2.

At the annual meeting of R. Wallace & Sons, Wallingford, Mass., directors were elected as follows the last being from Meriden: Robert Wallace, Col. Walter J. Leavenworth, Geo. M. Wallace, Frank A. Wallace, Geo. R. Curtiss, G. Rockwell and Geo. H. Wilcox. The board is the same as last year, except that Mr. Wilcox was elected in place of his father, the late Horace C. Wilcox. The directors elected Robert Wallace, president; Frank A. Wallace, secretary and superintendent; and Col. Leavenworth, treasurer.

Sumner Bro.'s Assets and Liabilities.

CLEVELAND, O., Feb. 13. — Assignee D. H. Graham of Sumner Bros., filed the following schedule of assets and liabilities in the probate courts Thursday:

Assets—Stocks \$61,966.82, book accounts, nominal value, \$44,257.79; appraised at

\$22,118.89. Personal property of C. E. Sumner \$140, of Milton A. Sumner \$375 and of Frank L. Sumner \$387, all under \$500, and hence all allowed as homestead exemption.

Liabilities—Total bills payable \$84,534.38. Contingent liabilities First National Bank, indorsed trade paper, \$51,500; Kinsman National Bank of Kinsman, \$5,000 (same); Davis Platform Binder Company accommodation notes, \$16,800. The First National is secured by real estate valued above encumbrances at \$10,000, and Sumner Bros. are indemnified against loss on the Davis Platform Binder Company accommodation notes in an \$18,500 mortgage on that company's plant.

Wrote Letters and Was Caught.

CLEVELAND, O., Feb. 11.—Last Thursday afternoon a man entered Webb C. Bell's jewelry store and purchased a pair of diamond ear-rings, and a diamond stud, and paid the amount, \$320, with a check drawn upon the Euclid Avenue National Bank. He also bought a locket, but left it to be engraved. The check was taken without being certified, and when presented for payment was pronounced worthless. The man, whose name is given as C. H. W. Schmidt, went immediately to the Home Security Company, where he pawned the stud for \$35, and then to another pawn shop where he pawned the earrings for \$80. He then left for Pittsburg, from where he wrote several letters to his wife, who is lying very ill at No. 46 Wood street. She paid no attention to the letters, and detectives watched the house, thinking he would probably return. Monday night their diligence was rewarded by seeing a messenger boy approach the house. He was intercepted. The boy then led them to a rendezvous appointed by Schmidt, and he was taken into custody. In Police Court yesterday he waived examination and was bound over to Common Pleas Court, being removed to the county jail yesterday afternoon.

Jewelers To Form a Syndicate.

PROVIDENCE, Feb. 14.—A new scheme, and one that appears reasonable, has been agitating the manufacturing jewelers in this city for several weeks past. Although not yet fully developed, the plans have been made and a meeting of the manufacturers held recently to consider the matter.

It is proposed to form a syndicate to be known as the "Corporation Syndicate of American Manufacturers." The company is to be capitalized for \$250,000, and the stock divided into 1,000 shares of \$250 each, one-fourth of the stock to be paid for in cash, on three calls, and the remainder to be paid in goods to be furnished by the shareholders when ordered by the syndicate for export.

It is the intention of the syndicate to open up an export trade with the South American countries, Australia, West Indies and the Sandwich Islands, introducing American goods in the markets of the countries mentioned, at prices far below those heretofore charged by the monopolies controlling exportation from America.

As a matter of course the preference will be given to the goods of stockholders, but it is intended to carry all lines of merchandise. The corporation will bear the expense of introducing the goods in foreign markets, and will handle them on a margin of 10 per cent.

The members of the syndicate are not bound to conduct their export trade exclusively through it, but are at liberty to sell independently as largely as can be.

It is proposed to establish a head office in New York city, with a branch in this and other cities. A meeting for the purpose of organizing will be held on Saturday evening, Feb. 21, at the Narragansett hotel.

The Special Meeting of the Jewelers' Security Alliance.

THE regular monthly meeting of the Executive Committee was held at the Alliance Office on Friday, February 13. There were present: A. K. Sloan, Vice-President; Chas. G. Lewis, Treasurer; and Messrs White, Croeber, and Geo. H. Hodenpyl, Secretary.

A letter was read from Mr. Pinkerton, in which he reported that through their efforts Jas., alias "Milky McDonald," the party concerned in the burglary of the safe of C. & A. Gabraetz, at Newark, N. J., had been brought back from Denver, Col., by one of their operatives and the sheriff of Bergen Co., N. J., and was now confined in the county jail at Hackensack. He is the man who was caught burglarizing the safe at Englewood, N. J., and broke jail at Hackensack. There is a strong case against him, and the probabilities are that he will get, at least, ten, and probably fifteen years. The following up of McDonald by the Jewelers' Security Alliance, his being brought back, and the certainty of his punishment ought to have a good effect upon his associates, and warn them to avoid any safe under the protection of the Alliance.

The following were admitted to membership:

Wm. Berens, Jr., 1018 7th street, Washington, D. C.; H. M. Hill & Co., 254-156 Union street, Lynn, Mass.; Geo. W. Huggins, 105 Market street, Wilmington, N. C.; A. W. & H. A. Reineman, 214 5th avenue, McKeesport, Pa.; Henry H. Snow, Randolph, Mass.; C. R. Smith & Son, 1746 Market street, Philadelphia, Pa.; C. B. Woodward & Co., Dakota avenue, Wahpeton, N. D., and C. B. Woodward & Co., Graceville, Minn.

The Hoffa Burglary.

WASHINGTON, D. C., Feb. 11.—The grand jury yesterday presented true bills against Joseph, alias Rory Simms, and Andrew McLaughlin, alias Andrew McMullen, alias Andrew Mullen, for breaking into the jewelry store of Frank Hoffa on Seventh street, on the night of October 11, 1890, and stealing fifty-eight gold hunting-case watches, nineteen filled case watches, eighty-one Swiss mounted silver watches, seventy-seven silver American watches, sixty-five gold chains, thirty-five gold rings set with diamonds, thirty scarf pins, and a lot of uncut diamonds.



Freedom of Different Parts.—Observe that there is sufficient clearance between the plate and barrel, the barrel and centre wheel; the several wheels in succession, both between themselves, their cocks, and sinks; between the balance on the one hand and its cock, the centre wheel, fourth wheel cock, the balance spring coils and stud on the other. The fourth wheel is frequently found to pass too near to the jewels forming the lower pivot hole of the escape wheel.

Visible Depths.—While the train is in motion through the force of the mainspring, or the pressure of a finger against the barrel teeth, examine with a glass all the depths that are visible. That of the escapement, for example, can be easily seen through the jeweled pivot hole where this is flat, the watch being laid horizontal and a powerful glass used. When the action cannot be seen in this manner with sufficient distinctness, hold the watch up before the light and look through it. Depths that cannot be clearly seen or about which any doubt exists, must be subsequently verified by touch.

Length of Balance Pivots.—Remove the endstone from the chariot, and see that the pivot projects enough beyond the pivot hole when the plate is inverted. Then remove the cock and detach it from the balance. Take off the balance spring with its collet from this latter and place it on the cock inverted, so as to see whether the collet is central when the outer coil is midway between the curbpins. Remove the cock endstone and endstone cap, place the top balance pivot in its hole and see that it projects a little beyond the pivot hole. Place the balance in the figure-of-8 caliper to test its truth, and, at the same time to see that it is sufficiently in poise; it must be remembered, however, that the balance is sometimes put out of poise intentionally.

To Fix a Drawing.—In fixing charcoal drawings, shellac is dissolved in alcohol until it is of a pale amber color. A good deal of shellac can be dissolved in alcohol before it seems to thicken much, and this feature is taken advantage of in preparing the so-called *Fixatif*. This is usually made of white shellac dissolved in wood spirits (*methyl*). White shellac is in some manner injured in preparation and is not as good as the ordinary shellac. The pale sherry wine-color does not injure the appearance of the drawing, as it only seems to warm the tone a little. A very soft camel's hair brush one inch wide is about the way to apply the solution of the shellac, and the solution should appear as thin as water when applied and sink into the paper and leave scarcely any gloss on the surface. The drawing is laid face down, and the solution pasted over the back.

THE BOWDEN Seamless Plain Ring,

IS MADE ONLY BY

J. B. BOWDEN & CO.,

Makers of FINGER RINGS of
every Description,

COR. BROADWAY & JOHN STREET,
NEW YORK.

Chicago College of Horology,

SUCCESSORS TO

THE CHICAGO HOROLOGICAL INSTITUTE,

IS ACKNOWLEDGED by those who have investigated
the subject to be a

FIRST-CLASS INSTITUTION,

Where those who desire to learn the art of WATCH
MAKING and ENGRAVING can obtain the

BEST PRACTICAL INSTRUCTION.

New features are continually being added. It is the
aim of those conducting the management of the
College to make it the

BEST INSTITUTION of the kind IN THE COUNTRY.

C. R. HART, *General Superintendent*,

CHICAGO COLLEGE OF HOROLOGY,

CHICAGO, ILL.

✉ WRITE FOR PROSPECTUS.

STOP!

ARTIFICIAL EYES!



STOCK ORDERS of
Selection Packages.

Largest Assortment.

GENEVA OPTICAL CO.,

23 Washington St., Chicago.

CHICAGO WATCH TOOL CO.,

52 MADISON STREET, CHICAGO, ILL.,

MANUFACTURERS OF

Staking · Tools, · Foot · Wheels, · Polishing · Lathes

AND ALL KINDS OF

WATCHMAKERS' AND JEWELERS' TOOLS.

Catalogues sent upon application.

WE WISH TO ANNOUNCE

That our line of Watches and Jewelry is now complete. Our stock is entirely new, and comprises everything pertaining to the legitimate jewelry trade.

CAN WE SERVE YOU?

KATLINSKY & GATZERT,

WHOLESALE JEWELERS,

96 STATE STREET,

CHICAGO.

WELDED CHROME STEEL AND IRON

5 PLY.

FOR BUILDING



Jewelers' Safes, Vaults, Etc.

Positively Burglar Proof, cannot be Cut, Sawed or Drilled.

OUR TRADE MARK is stamped on all our goods and we caution purchasers to avoid imitations. We are the sole manufacturers of *genuine Chrome Steel* in the United States.

CHROME STEEL WORKS,

Kent Avenue, Keap and Hooper Sts., Brooklyn, N. Y.

S. H. KOHN, PRES. C. P. HAUGHIAN, VICE-PRES. J. G. DUNSCOMB, SEC.



DIAMOND SETTINGS.

GALLERIES.

HOLLOW BALLS, ETC.

BLANCARD & CO.,

36 & 38 JOHN STREET,

SEND FOR OUR

NEW YORK.

CATALOGUE.

PETER HENRY,

MAKER OF

Special Watch Cases

For American, English and Swiss Movements,

No. 56 Longworth Street,

Room 4, Second Floor, CINCINNATI, O.

Key Winders changed to Stem Winders.

English Cases changed to fit American Movements.

Hunting Cases changed to Open Face.

Old Watch Cases Reconstructed, Repaired and Renewed.

LOW PRICES, GOOD WORK AND PROMPT ATTENTION GUARANTEED.



W. ROSENTALL,

Manufacturer of

SILK VEST CHAINS,

79 NASSAU STREET, NEW YORK.

Send for Selection Package with reference.

G. F. FEINIER,

MANUFACTURER OF

WATCH CASES,

Repairing of Every Description,

NO. 9 BOND STREET, NEW YORK.

Key-Wind Cases Altered to Stem-Wind, and made same as New. English Cases Altered to take American Movements.

JOHN A. RILEY,

860 Broadway, New York,

MAKER OF

Hair Pins, Plain and Gemmed, Grecian Fillets,
 BROOCHES HAT PINS
 BRACELETS QUEEN CHAINS
 SCARF PINS SCARF HOLDERS.

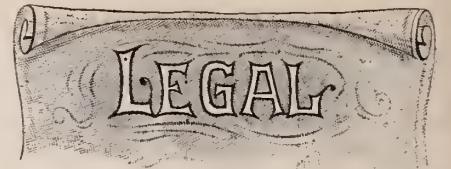

LIABILITY FOR ADVERTISING CONTRACT.

Evidence that plaintiff in his newspaper published an advertisement for defendant at a price agreed on with defendant's agent; that he mailed a copy of his paper to defendant's address for one year; and that defendant never refused or returned the same, is sufficient to make defendant liable for both the advertisement and the subscription.

BREACH OF CONTRACT FOR SALE OF GOODS.

Where a bill of goods is sold upon the agreement of the buyer to deliver a negotiable note payable in one year with interest, this is not an agreement to give a credit of one year for the goods, and upon the refusal of the buyer to deliver the note as agreed, the seller may proceed at once to recover the price of the goods, and need not wait till the year has expired.

LIABILITY OF WIFE FOR GOODS.

In order to charge a wife on her individual account with goods purchased for the use of the family, of herself and husband, it is necessary to show that the credit was extended specifically to the wife, and in this connection it is competent to show that the same credit would not have been extended to the husband. But it must appear clearly that the credit was in fact given to the wife and that the charge on the books was made to her.

SIGNATURE OF NOTE BY OFFICER OF CORPORATION.

Where a person who is an officer of a corporation signs his own name to a note with the title of his office added to it without including the name of the corporation, the signature binds him personally unless he shows that the debt was one which the corporation had authorized to be incurred, and one which it had the power to incur, and that at the time the note was executed the payee understood it to be the note of the corporation.

LIMITATION OF LIABILITY FOR NEGLIGENCE OF CONNECTING CARRIER.

Where a shipper of goods accepts a bill of lading which provides that all liability on the part of the carrier to whom the goods are first delivered shall immediately cease upon delivery of the goods to another carrier, and that "for all loss and damage occurring in the transit of said packages, the legal remedy shall be against the particular carrier or forwarder only in whose custody the said packages may actually be at the time of the happening thereof, it being understood that this company assumed no other responsibility for their safe carriage or safety than may be incurred on its own road," the stipulation is a valid one and will be enforced against the shipper.

Listening to the Beating of a Watch.

Many defects which may be discovered by these means—Some suggestions as to how to correct them.

(Continued from page 9, Feb. 11.)

A BADLY polished pivot, or one which does not move perfectly free, also causes a noise. We find pivots which appear to have been well made, but on examination small defects will be discovered on them—say on one side only, either by reason of some accident or from a defect in the material. In this case the noise produced issues from only one place, and this circumstance is a reason why when listening to the going of the movement it is well to turn it toward all sides, so as to be certain that everything moves with necessary freedom.

We sometimes hear a strong roaring, which proceeds generally from pivots that have not been well polished. It is generally sufficient to carefully correct them in the mandril.

It happens sometimes that we find pivots which are too short, either by reason of the distance between the jewel hole and the cap jewel, or else because the jewel hole is too long. In this case the shoulder or turned-down angle of the pivot occasions a friction with the angle of the jewel hole; sometimes the cap jewel does not answer, and consequently causes a serious friction.

The opposite defect is occasioned by the jewel hole and cap jewel fitting too closely together. If the hole is rather short and permits much shake to the balance, then the angle of the pivot end produces a bad friction by beating against the angle of the jewel hole.

The jewel holes also cause noises if they are badly polished and grind the pivot, or if they contain diamond powder. Again, they are too long and badly shaped, or else so short that they cut and scratch the pivot. A hole may on casual inspection appear to be good. A noise causes us to inspect it more closely, when we find that it is not polished

on one side, or else that it is not round; it is sometimes even oval.

The cap jewels also possess defects perceived by the ear when they are not well polished, when badly set or not entirely flat. On close inspection we often find one full of little points, against which the pivot end wears, and thus make the noise.

The jewels and cap jewels which are not fixed firmly, or set badly, the want of oil, too much shake of the balance, etc., all are causes productive of noise distinguished by the ear.

In the anchor escapement we also may hear the noise of other defects in the functioning of the escapement; for instance, the hora of the tool being longer than necessary the want of shake of the rollers or the defect of the disc; the ruby pin striking somewhere, or else not being fixed firmly. Again, there may be one or two teeth of the escape wheel which do not pass with sufficient surety upon the one or the other of the liftings; the want of drop; or the wheel scrapes on the center of the anchor. For this reason it is necessary to listen until the scape wheel has made at least one rotation, so as to be satisfied that everything passes off in the regular manner in the escapement.

Some of the imperfections in the balance spring and parts belonging to it can be heard. Such as balance spring buckle or stud scraping on an arm of the bala or thence collet lacking space with the flat of the cock and the screws of the small cock; sometimes the balance spring butts against the stud in its act of unfolding and at others against the centre wheel. In certain cases the Brequet spring rubs slightly on the arm of the balance.

The motion of the balance spring between the curb-pins is frequently heard. It is hurtful and produces a sound readily made to disappear by slightly lubricating the pins. As a precaution, clean at once with elder pith or gentian, so as to prevent a hurtful excess.

It is not always possible to directly locate the source of noise. In this case it is advisable to only place in the balance with spring and cause it to vibrate—that is without any other parts of the escapement—and

in this manner the watchmaker can ascertain the precise spot of the ailment.

From the above it will be seen that the number of defects that can be distinguished by the ears is quite large, and it goes for nought if we say that the list is not by any means complete. It may be replied that the repairer should see all the defects enumerated. But in these days everything goes at a rush, or else, if the watch is in incompetent hands, the inspecting foreman can at least satisfy himself in this manner that everything is right.

Instigated by the experience the writer has gathered in this particular, he thought it might be well if his fellow-workmen were to adopt it also.—OSCAR PERRET, in *Almanach des Horlogers*, 1891.

Chronology of the Principal Inventions In Horology.

THE reader of THE JEWELERS' CIRCULAR, when looking at the appended list of the discoveries and inventions made in horology during the eighteenth century, achievements which may well be ranked among the most useful, and of incalculable benefit to mankind, is well tempted to ask what the modern watchmakers have invented.

He is easily answered by the rejoinder, next to nothing. The substitution of a pin for a screw, or the displacement of a screw or pin, cannot be called an invention. Watchmakers of the past century, aided by advancing education, gradually began to comprehend more fully the power and adaptability of wheels and pinions, and the manufacture of complicated clocks and automata, hitherto confined to mathematicians and astronomers, was seized upon and improved by the watchmaker at large.

New escapements were planned and existing ones improved. In fact, the horology of our day commences only with the introduction of the pendulum, claimed both for Huyghens and Galileo, and the balance spring by Dr. Hooke. In order not to disarrange

— THE —

COURVOISIER, WILCOX MFG. COMPANY



Will PUT on the market about the middle of February, a New 10-K. Gold Watch Case in O and 6 size, which for beauty of design, finish and style, will be unsurpassed.



It will be stamped

WARRANTED
STANDARD
U. S. ASSAY.
C. W. MFG. CO.



the interesting series of inventions, let us commence our dates from the application of the pendulum to clocks, 1656.

1658. Dr. Robert Hooke invented and applied the balance spring.

1675. Barlow and Quare, of London, constructed the repeating timepiece, first for mantel clocks, next for watches.

1680. Dr. Hooke invented the clock anchor recoil escapement.

1691. Daniel Quare applied the minute hand. (Timepieces had until then only one, the hour-hand.)

1700. Graham invented the compensated mercury pendulum.

1702. Graham invented the Dead-beat or "Graham" escapement, and the cylinder escapement.

1704. Falio, of Geneva, pierced rubies and used them for jewel holes.

1720. Harrison, the "extraordinary genius," invented the maintaining power of clocks and watches.

1726. Harrison constructed the compensated gridiron pendulum.

1754. Caron de Beaumarchais invented the pin escapement for watches.

Mudge invented the detached-lever escapement.

1760. Ellicott invented a peculiar compensation pendulum.

1761. Harrison, 67 years old, constructed the first marine chronometer.

1765. Pierre Le Roy invented the compensated balance.

1770. Stogdes invented the half-quarter repeating escapement, used mostly in English watches.

1770. Duplex, an Englishman, invented the escapement named for him.

1775. Whitehurst invented the "Tell-tale" clock.

1780. Arnold invented the marine chronometer with detent escapement.

1780. Earnshaw invented the spring detent escapement and the compensated balance, both substantially as now used in chronometers.

1792. Breguet invented the *tourbillon* escapement.

1790. Breguet applied the volute spring named for him.

Next to the English, the Swiss rank in importance. Neuchatel and Geneva contained several large industrial floats, in which watches with all the improvements of the times were manufactured and shipped to

all parts of the world, as an article no longer of luxury, but of necessity. One of the most deserving of Swiss watchmakers was Ferdinand Berthoud, born in the Canton Neuchatel in 1727. He exerted an extraordinary influence on horology, not only by his writings, but also by his work, which was esteemed as excelling in quality that of Harrison. His passion for the art was so great, that at the age of 80 he went to California, at that time a *terra incognita*, to ascertain the rate of a clock with a new escapement, and died in that country.

The Louis XV. Fad.

Wide-a-awake jewelers know that the drawing-rooms of wealthy folk are being furnished in Louis XV. style, and that is why they are importing such charming bric-a-brac in onyx and ormula, Sevres and Dresden-china and enamel. Modern drawing-rooms decorated in French style, contain one, two, three or more cabinets for the display of art objects. Especially designed for these, are miniature affairs in silver that take on the forms of Louis XV. furniture and are decorated in colored enamels. These tiny treasures for which purchasers pay any where from \$50 to \$150, each, are veritable works of art, but in some cases they are utilized in a common-place way by making of them watch stands, jewel receptacles and the like. Old silver, also imitations of rare specimens find their way to these museum cabinets. Delft ware is very fashionable at present; so are all kinds of French porcelains. Tortoise shell, which, by-the-by, our manufacturers employ chiefly in the making of personal ornaments, appears in the French bric-a-brac in form of clocks, photograph frames and jewel boxes, with trimmings of perforated silver.

ELSIE BEE.

It Suits Them.

BEAUFORT, S. C., Feb. 6, 1891.

Enclosed find two dollars to renew our subscription to THE CIRCULAR. We would not think of doing without it, and now that it has become a weekly we want it more than ever.

WHITMAN & BRISTOL.

PORT CHESTER, N. Y., Jan. 6, 1891.

We plead guilty of a very high opinion of the value of the JEWELERS' CIRCULAR.

J. H. GILBERT.

ALVIN MFG. CO., Silversmiths,

860 Broadway, New York,

206 Kearney St., San Francisco.

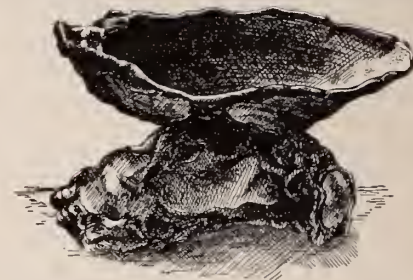

DESIGN—OYSTER SHELL—SALT.

MADE IN LARGER SIZES FOR ASH TRAYS, &c.

Design Patented.

GILBERT T. WOGLOM

BLACK MAKER OF Pearl Ornaments and Plain
JEWELRY. **ONYX**
GOLD MOUNTED.

32 & 34 John St. New York City.

GENTLEMEN:—I think the trade this Spring will be better than last, and, although I can turn out double the work I did then, you had better be on hand with your orders, for I expect that my sales will be very large—equal to last Fall, if not double. You see the field is constantly widening and the demand is increasing, and why? Did you ever stop to think that there are 65,000,000 people in the United States, and the per cent. of this number that use glasses is one-fifth, or 20%, making 13,000,000 people wearing eye-glasses, and if you count the myriads in Europe and South America, why it is simply immense, and it needs cultivation. Why! Gentlemen, we ought to be able to double our business every year for the next ten years.

Yours respectfully,
Springfield, Mass. S. F. MERRITT.

VACHERON & CONSTANTIN, GENEVA, SWITZERLAND.

FINEST QUALITY OF WATCH MOVEMENTS, FITTING
ALL SIZES OF AMERICAN CASES.



CHAS. LEO ABRY,

Agent for the United States and Canada.

41 and 43 Maiden Lane, - - - NEW YORK.

The Other Side of Life.

A GREAT SCHEME.

JINGLEPOP—I saw you buying an alarm clock yesterday. Have you to get down early?

CHIDWIDLER—No-o. I bought it for the purpose of being waked-up, so that I can enjoy the bliss of turning over and going to sleep again.

THE USE OF SUPERSTITION.

In the restaurant. SNODGRASS—Are you superstitious, Snively?

SNIVELY—Superstition is for children.

SNODGRASS—Then let me have that bill of goods I placed with you this morning on thirteen months, time.

THE ROAD TO FORTUNE.

“You look prosperous.”

“I am prosperous.”

“What line are you in?”

“I manufacture a complete assortment of silver antiques.”

PREPARATIONS FOR THE SPRING.

FIRST BOSTON MAIDEN—Oh, mamma and I have been awfully busy to-day.

SECOND BOSTON MAIDEN—Do say! And what has made you so busy?

F. B. M.—We have been getting out and cleaning our spring spectacles.

IT LOOKED LIKE ONE, BUT WAS NOT.

ALICE (in Henry Stanley's library)—Oh, Mr. Stanley, what a queer necklace that is

over your mantel! How unique! Where did you find it?

HENRY STANLEY (quietly)—That's a petticoat that a belle in Umji Jimji wore at Queen Ouou Hehe's reception.

HE TOLD THE TRUTH.

PRESIDENT BOARD OF POLICE COMMISSIONERS—We are sorry to say, O'Hoolohan, that you are discharged from the force.

O'HOOLAHAN—An' fer phwat cause, yer honor?

PRESIDENT—A jewelry store was burglarized in your district last night. Did you meet any one on your beat last night?

O'HOOLAHAN—Yis, your honor. I met a man an' he said, said he, he was going to open a jewelry store.

PRESIDENT—He did open a jewelry store and stole \$5,000 worth of goods.

O'HOOLAHAN—The man may have been a hafe, but he was no liar

ONE USE OF THE DIAMOND.

At Object Lesson. TEACHER—What are some of the uses of the diamond?

JOHNNY—I only know one.

TEACHER—Well, let me hear that.

JOHNNY—To make popper dream he is going into bankruptcy.

WENT HIM ONE BETTER.

“There goes a millionaire who started life without a cent to his name.”

“You see that man opposite? Well, he's a millionaire and he started life without a name.”

AIKIN, LAMBERT & Co.,
23 Maiden Lane,
NEW YORK,

Manufacturers and Exporters of
Fine Gold Pens, Pencils,
TOOTHPICKS, HOLDERS,
And Novelties in Silver, Pearl, &c.



THE BEST FOUNTAIN PENS.

New Assortments in SHOW CASES and FANCY TRAYS for JEWELERS.
Price Lists and Catalogues for intending Purchasers.



Also American and Swiss Watches.

DIAMONDS, Loose and Mounted,

Gold and Silver Thimbles,

CHAINS and JEWELRY in New and Staple Patterns.

TO THE TRADE.
FINE WATCH REPAIRING

BY
JOHN C. SIMMONDS,

18 JOHN STREET, NEW YORK.

New pieces, such as Chronometer Locking Springs, Balance Staffs, &c., made in the best styles. Watches sprung and adjusted to temperature and positions.

ESTABLISHED 1841.

CARTER, SLOAN & Co.,

MANUFACTURERS OF

FINE JEWELRY,

15 MAIDEN LANE, NEW YORK.

A. CARTER, JR.
A. K. SLOAN.
C. E. HASTINGS.
GEO. R. HOWE,
WM. T. CARTEP.



Factory, NEWARK, N. J.

Superstition About Precious Stones.

“IT is singular,” says a European writer, “that the superstition yet lingering about precious stones represents, happily, a fast-diminishing quantity. Who would think now-a-days of attributing to each stone a special influence over each month, and wearing, therefore, the sapphire in April, the agate in May, etc? Yet our ancestors did this, and even appropriated to twelve kinds of stones the twelve signs of the zodiac and the twelve apostles. Perhaps there was some pious intent in making the jasper the symbol of St. Peter, the chrysolite of St. Matthew, and the uncertain beryl of the disbelieving St. Thomas. But the modern spirit does not require these reminders, and their value, at any time, must have been very doubtful. But, smile as we may at the superstition that ruled in by-gone times with regard to precious stones, we have to admit that it was not altogether without its brighter side. In the dark ages, for instance, it can have afforded no small happiness to possess gems which, like the diamond and amethyst reduced war to a safe and pleasant pastime. What charm have we wherewith to face the perils and misfortunes of life, that are comparable to the faith in their talismans which supported our ancestors? Who that remembers the agitations of a lawsuit and the nervous reliance the litigator placed in his solicitor, but might respect the faith that, in a previous age

and similar plight, he might have felt in a morsel of chalcedony?

Science, moreover, in many cases, leaves no compensation for the beliefs she dispels. It was no trifling alleviation of the peasant's lot that he might hope any day to find a rich jewel which had been left by a snake in the grass, or vast treasures hidden in a mountain.

This hope is now gone, or going, from him, and perhaps few living Cornish peasants now look for the blue stone ring which their ancestors attributed to the action of snakes breathing upon hazel.

Who now that drinks the refreshing Vouvray wine, from Vouvray, in France, would ever think that the name of both wine and place had come from an old local belief in a dragon or viper (*vouivre*) that possessed a single eye, or carbuncle, which it laid aside on the ground, and which, if discovered, would lead its finder to immeasurable riches.

The Shape of the Drill.

THE forms ordinarily adopted for the blades of drills are too well known to require specific mention. It may be generally formulated that the blade must not be too thick, as, if it were, there would not be a sufficient cutting edge. As the hardness of the metal operated upon increases, the thickness of the blade must proportionally increase; or, what amounts to the same thing, the two slopes that form the cutting edges

must have a less acute degree of inclination. If this condition of sufficient thickness be satisfied in a drill it will perforate steel well.

A drill may be asserted to be good if it satisfies the following conditions: The point must be in the middle of the blade; it must be made of good steel that is carefully hardened, without being heated to the proper temperature; and it must be quite true—in other words, in rotating it must run with such trueness throughout the entire length that it will withstand the end pressure required to cause it to bite, and will not bend.

It must not be forgotten that: 1. If a drill is drilling too rapidly it will heat, and thus become softened as though too much tempered. It is with a view to preserve this that, when operating upon iron or steel, many workmen now and then dip the drill into a cold liquid, (turpentine is good for this purpose) dry it and resume drilling, the hole being liberally supplied with oil. 2. When a blade is left too hard, or if the cutting edge be too acute, or if a feather edge has been left by the oil stone, small hard particles that are detached from the drill will imbed themselves in the hole. This will especially be the case if it is worked too rapidly, or with jerks. Such particles render the operation of drilling very slow and difficult. 3. For a given throw of the bow, the velocity increases as the diameter of the ferule is reduced, and the force applied increases with this diameter and the tension of the strings of the bow.

WATERBURY CLOCK CO., CLOCK MANUFACTURERS.



SALESROOMS:
10 Cortlandt St., New York,
GEO. M. VAN DEVENTER, AGENT.

SALESROOMS:
114 & 116 Wabash Avenue,
CHICAGO,
H. S. PECK, AGENT.

SALESROOMS:
528 & 530 Market Street,
SAN FRANCISCO.
A. I. HALL & SON, AGENTS.

FACTORIES:
Waterbury, Conn.



123 Stockwell Street, Glasgow,
T. R. DENNISON, AGENT.

NEW DESIGNS
Class-Rings
and Pins



RAZZLE PUZZLE "Medal very satisfactory."
DaZZle "They are now beautifully made in sterling silver, and gold."
OPEN Rings made by Haskell, New York. Surprising popularity of this ring the phenomena of the day. Everybody is buying them. This novelty has created quite a sensation—Jewelers Weekly
NOVELTIES IN GOLD AND SILVER "Many thanks for rushing work ordered."
Special Designs sent upon request
HENRY C. MASKELL
 MAKER OF FINE JEWELRY,
 11 JOHN STREET, NEW YORK.

COPYRIGHT PLATES
Sent to Dealers upon request.

Providence Jewelers Interested.

THE recent failure of Taber Bros. Jewelry Company, Dallas, Texas, although at a considerable distance from Rhode Island involves no small amount of interest. No less than thirty-five firms in and about this city are creditors of the concern to an aggregate amount in round numbers of \$9,500, in addition to about \$4,000 distributed among eleven Attleboro firms, altogether making about one-half of the entire liabilities, which are placed at \$30,594.31. The other creditors are located in New York City, St. Louis, Buffalo, Cleveland, Chicago and other western cities.

While the average indebtedness to Providence firms does not exceed \$300 each, the heaviest creditor on the entire list is a prominent jeweler of this city, who suffers to the extent of \$2,063.29. The other firms having claims over \$1,000, are four located in New York City. The officers of the Dallas concern are J. C. Taber, president; S. H. Taber, secretary, and N. A. Bolles, treasurer. But the Tabers were believed to be the virtual owners of the business, being at one time in the same line at Cairo, Ill., where they were reported unsuccessful. In 1883 went to Dallas, where in March, 1888, they were succeeded by the present corporation. On May 10, 1888, the company's business was destroyed by fire. The firm received \$6,700 insurance and continued until November 13, 1890, when it was again visited by flames. The policies, amounting to \$23,000 were reported made over to the Fourth and Ninth National Banks of Dallas, and on the evening of January 26, 1891, the concern made a general assignment for the benefit of the creditors to John Alcott.

Another wholesale jewelry firm which recently assigned, in which Providence firms were interested, was that of Sumner Bro., of Cleveland, O., whose statement show appraised assets to be \$89,655.88; direct liabilities about \$85,000; and contingent liabilities \$101,300. The members of the New England Manufacturing Jewelers' Board of Trade are creditors for about \$12,000. There is little hope of getting more than 25 or 30 cents on the dollar.

ESTABLISHED 1873.



If for any reason you should desire the services of an AUCTIONEER, and will write me as to the amount of stock you have on hand and its general character, the size of your store and the number of inhabitants of your town or city, I could, from my extended experience, give you an idea of the amount of business you could expect under the circumstances, and, no doubt, be able to refer you to some one for whom I have sold under conditions similar to your own.

As a general reference, you could hardly find a wholesale jeweler who is not familiar with some of the numerous successful sales I have made.

I have made many successful AUCTION SALES, and have yet to record a failure to fully satisfy the owners. Can give you hundreds of references to that effect.

If the business should be urgent and I am myself engaged, I have two competent assistants instructed in my methods whom I could send on short notice.

Any correspondence with me will be strictly confidential in every case.
P. O. Box 2775.

NEW YORK CITY.

FLEUR DE LIS BROOCHES.

ALSO A FULL LINE OF

STERLING .: SILVER .: JEWELRY,

INCLUDING

Love Locketts, Brooches, Lace Pins, etc.,

And also in first quality Rolled Plate.

R. BLACKINTON & CO.,

New York Office,

No. Attleboro,

182 BROADWAY,

MASS.

J. R. MORSS.



MATHEY BROS., MATHEZ & CO.

16 MAIDEN LANE, N. Y. AND BRASSUS, SWITZERLAND,

MANUFACTURERS AND IMPORTERS OF

Plain and Non-Magnetic Movements.

Complicated Watches a Specialty.

**CHRONOGRAPHS,
MINUTE REPEATERS,
AND
SPLIT SECONDS,**

IN ALL GRADES AND SIZES.

SOLE AGENTS FOR

H. L. Matile, C. H. Meylan and J. J. Badollet. Watches Demagnetized.



REPEATERS



CHRONOGRAPHS.

The Queue of His Excellency.

DURING my residence in Stockholm, Sweden, I frequently met in my walks an individual—aged in years, but still young in liveliness. He was always brimming over with jokes. We soon formed a firm friendship, and hardly ever a day passed during my two years' stay there, but that we were in each other's company. "Two souls with but a single thought" of killing time as agreeably as possible. My friend had been a traveler in his earlier years, and by dint, as he often laughingly told me, of adroit lying and skillful manipulation of the wealthier classes of his customers, he had succeeded in laying aside enough of the gold, which he did not sell, to prepare for himself an independent afternoon and evening of life.

"People earned their money more easily in those days," he said, "there were not so many of your prying and snooping 'experts', so it was much easier to sell a piece of glass, cleverly underlaid with foil, for a ruby or emerald, than at present. Heigho! Those good old days! By the way, I'll tell you a little occurrence, which for a time looked very gloomy for me, but out of which I came without damage.

I kept a workshop to accommodate my high-toned customers. Those of lower pedigree had to patronize shops of lower degree than mine, while my store was the rendezvous of the titled and wealthy. One of my best customers, His Excellency, the Duke of P. died. He was one of the wealthiest men of the country, and a great favorite at Court. The corpse of His Excellency, clad in all the pomp and circumstances of his station, was publicly exposed in his palace. He was dressed as minutely as in life, even the little red spots of rouge on his cheeks were not forgotten. He was to carry with him to his grave as much of the distinguishing characteristics of wealth as he could with which to impose on Charon. He looked very handsome while his snowy silver white hair braided into a queue, as was the fashion in my young days under Gustavus III., capped the climax. By the way, His Excellency had always been famous for his snow white hair.

His heirs, in the first paroxysm of gratitude to him for having himself taken off so timely, agreed to cut off his queue immediately before the coffin closed over the remains forever. The next day one of them presented himself in my store, and ordered fourteen rings, each to bear a lock of the queue. I locked the queue into my storage box—we had none of your newfangled "safes" in those days—and set my journeymen to work constructing the fourteen rings. They were soon ready, and awaited the hair. I opened the box to produce it; but, oh, horrors! where was the queue? Wife, children, servants, journeymen, apprentices—all were interrogated, but none had seen it.

Yes, one! my six-years' old boy finally acknowledged that two days before the box stood open, that he had seen the white hair and had taken it out. Just then the unlucky kitten

had come around him and he and the cat had played with it. She had finally carried it off, but he knew not whither. House, yard, garden, cellar, garret, were ransacked but to no purpose. The cat was abused, the boy beaten; so justice received its dues. But the queue could not be found.

I was in a terrible predicament. My name and reputation stood in jeopardy. I, the simple, untitled goldsmith, who enjoyed the distinguished honor of working for royalty, court and—courtezans, His Excellencies and Her Excellencies of all sorts, should be so little mindful of the honor done me as to lose the queue of that dear old His Excellency. I imagined my customers dropping away from me by the dozen. I said farewell to home and journeyed through Sweden trying to find a queue like that of the dear departed. But I might as well have stayed at home, because I found no hair, neither on prince nor beggar, at all approaching the lost queue. The heir who had ordered the rings had been to the store repeatedly during my absence. My wife, however, gifted with all the astuteness of her sex, had put him off from day to day; but the heir had declared on his last visit that he either wanted the rings or the queue in three days—two days more. My wife saw how heavily the loss weighed upon me, and declared that come what might, I would either have to accompany her tomorrow on a trip to the country, simply for my benefit, or else she would have me examined in court touching my sanity. Listlessly, I chose the former alternative.

When outside the city limits she arranged for a boat sail on the Mälär Lake. Boat! Mälär Lake! I felt more like scounding its depths than skimming its surface. After an hour's sailing, we land at a green, shady place, near a little log cabin. My wife produced a lunch, and we sat down to eat and drink but not "be merry." After eating, she arose to look for flowers leaving me alone devising ways and means for recovering the lost queue. While still engaged in this pleasant cogitation, I heard a noise behind me; I looked around, and a large billy-goat was just ready to make me acquainted with the horns of his dilemma. I jumped up, surveyed him and his magnificent beard—the queue!

I need not tell you that it took but a few seconds to rush into the cabin with the question:

"Whose goat is that?"

"Mine."

"Do you wish to sell him? That is, I do not want the goat so much as his beard. Do you want to sell it for a good, fair price?"

"Yes."

"The bargain was struck, Mr. William Goat caught and shaved, and in one minute I had the most beautiful queue of His Excellency in my pocket. Quick, quick, for home! My journeymen worked all night, and next morning I donned my Sunday dress and delivered my rings."

"But did no one ever find it out?"

"Well, to tell the truth, I felt kind o' squeamish for two or three weeks, but understanding human nature, and knowing

that the rings would be worn only until the heirs had assimilated the property bequeathed, I lost all fear of being detected. It is now a number of years ago, and not one of them, in case he wears his ring dutifully, has ever found out that it contains hair from the head of a billy-goat, instead of that from the queue of the dear departed, His Excellency."

To Drill Steel of Blue Temper.

AT first not much difficulty will be experienced in drilling blue tempered steel, but when the drill has reached a certain depth, and the metal seems to oppose a gradually increasing resistance, the operation must at once be stopped. If the blade of the drill be now examined with a glass, it will be easy to see which points have ceased to cut, producing instead a series of bright rings at the bottom of the hole that are very difficult to remove. Exchange the drill for one of a different form; or, without reducing its width, change the form of the blade. If it was arrow headed, for example, make it semi-circular or semi-oval, or chisel shaped with sloping edges. All that is essential is that the form be so changed that the bright portion of the surface shall be gradually removed, and that no attempt be made to act on the whole bright surface at once. Until this hard portion is removed, the blade will require frequent sharpening.

Some recommend that the hole be moistened from time to time with dilute nitric acid, which is washed off and renewed when a shiny surface is produced. Oil may with advantage be replaced by turpentine as a lubricant for the drill blade.

The formation of hard, shining surfaces is attributed to three causes: 1. To the cutting edge being rounded, rolling, as it were, and hardening the surface of the metal against which it continues to move. 2. To the drill being made of poor steel or imperfectly hardened, so that small particles break off and are imbedded in the metal operated upon. 3. To a deficiency in the supply of oil, or a too great velocity of rotation of the drill.

A New Clock Factory, Perhaps.

ROCHESTER, N. Y., Feb. 7.—An Akron, N. Y., jeweler and the inventor of a patent electrical clock, is in this city to-day calling on the members of the Board of Trade, looking toward the formation of a local company to manufacture his novelty. It is understood the clock is one possessing many advantages, and it is not improbable that a company will be organized to push the work. It was found impossible to organize a company at Akron, where the new time piece was first brought out.

THE Mermod & Jaccard Jeweler Co., of St Louis, keep a register in which they record the visits of all traveling men who call upon them. This record shows date of arrival name, departure and next address of the drummer. The record will be open to the inspection of all travelers who wish to know where their friends on the road can be found.

Recent Patents

Issue of February 10, 1891.

DESIGN No. 20,508. SCARF PIN. EDWARD BEACH, Newark, N. J., assignor to Unger Brothers, same place.—Application filed December 26, 1890. Serial No. 375,862. Term of patent 3½ years.

DESIGN No. 20,509. HANDLE FOR SPOONS, &c. WILLIAM B. JONES, Newburyport, Mass.—Application filed December 19, 1890. Serial No. 375,211. Term of patent 7 years.

DESIGN No. 20,510. SPOON. WALTER L. WILKS, Bridgeport, Conn., assignor to The Holmes & Edwards Silver Company, same place.—Application filed December 15, 1890. Serial No. 374,815. Term of patent 14 years.

DESIGN No. 20,511. BADGE. LOUIS E. STILZ, Philadelphia, Pa., assignor to The Supreme Castle of the Order of the Knights of the Golden Eagle, same place.—Application filed January 15, 1891. Serial No. 377,894. Term of patent 14 years.

DESIGN No. 20,518. BROOCH OR SIMILAR ARTICLE. EDWARD P. BEACH, Newark, N. J., assignor to Unger Brothers, same place.—Application filed December 26, 1890. Serial No. 375,861. Term of patent 3½ years.

TRADE MARK No. 19,011. VEST CHAINS. D. C. PERCIVAL & Co., Boston, Mass.—Application filed January 14, 1891. Used since July, 1890. "The word 'GYMKHNA'"

TRADE MARK No. 19,002. VEST CHAINS. D. C. PERCIVAL & Co., Boston, Mass.—Application filed January 14, 1891. Used since January, 1887. "The representation of an anchor."

446,081. FOUNTAIN-FEED FOR MOISTENING AND SEALING DEVICES. PHILIP J. SCHREIBER, Dayton, Ohio.—Filed Feb. 25, 1890. Serial No. 341,777. (Model.)

Claim. 1. The combination of a tube, provided with a tank, disk, hollow tube, with lips or jaws, loose ring and pin, substantially as and for the purpose, set forth.

2. The combination of a tube, provided with a tank, disk, hollow tube, having lips, loose ring, pin, and attachment, with pen and pencil holder, substantially as and for the purpose set forth.

446,202. FOUNTAIN-PEN FILLER. FRANCIS C. BROWN, New Brighton, N. Y., assignor to Marie Brown, same place.—Filed Oct. 10, 1890. Serial No. 366,684. (No model.)

Claim. The combination is a flanged bottle-stopper A, having formed thereon and made integral therewith an air-bulb B, with the perforated core E, embraced by said stopper A, and with the tube D, held in place by said core E, between the same and the external stopper A, all arranged substantially as herein shown and described.

446,202. TIME-ALARM FOR CULINARY PURPOSES. WILLIAM E. GROVES, Boston, Mass.—Filed Dec. 3, 1889. Serial No. 332,413. (No model.)

Claim. 1. An alarm mechanism provided with a stop, break, or slide adapted to engage automatically with the periphery of the balance-wheel to stop its movement when the alarm has sounded and to be moved in a tangent therefrom by the operator, the latter movement serving to release and start the balance-wheel and to impart tension to the alarm-spring, substantially as set forth.

2. The case, with a suitably-actuated train of gearing, the indicator-hand, alarm devices, and alarm-spring, in combination with the curve slide, connected to a lever protruding through the case, whereby the slide may be disengaged from the periphery of the balance-wheel by the operator and engaged therewith by the action of the alarm-spring, substantially as set forth.

TOWLE MFG. CO.,

MANUFACTURERS OF



Sterling Silverware



NEWBURYPORT, MASS.: 214 MERRIMACK ST.

CHICAGO:

SAN FRANCISCO:

149 & 151 STATE ST.

220 SUTTER ST.



STERN BROTHERS, "S"

A "NOVELTY" in Marquis Rings.

SEND FOR SAMPLE.

Manufacturers of Fine DIAMOND MOUNTINGS.

42 MAIDEN LANE, N. Y.

JOSEPH JONAS.

JACOB DORST.

JONAS, DORST & CO.,

Manufacturing Jewelers and Importers of Diamonds.
169, 171 RACE STREET,
CINCINNATI, OHIO.



WE MAKE A SPECIALTY OF ALL STYLES OF
DIAMOND MOUNTINGS.

Society and School Badges,

FANCY MONOGRAMS and RINGS of all Descriptions.

We are prepared and have complete facilities for doing REPAIR WORK with neatness and dispatch.

DESIGNS EXECUTED FOR SPECIAL WORK

We are the exclusive manufacturers of the celebrated Ophir Diamond Goods.

R. & L. FRIEDLANDER,

Wholesale Jewelers,

—AND—

JOBBER'S IN AMERICAN WATCHES,

Tools, Materials and Optical Goods,

65 & 67 NASSAU STREET, N. Y.

Factory, 50 BOND STREET.

Send Business Card and we will mail you our Watch and Jewelry Catalogue No. 12. and our Tool, Material and Optical Catalogue, No. 14.

Try our Monarch American Mainsprings, \$12.00 PER GROSS, \$1.00 PER DOZEN.

POSITIVELY NO GOODS SOLD AT RETAIL.

Utica.

Mr. Benjamin and the S. D. Mills Jewelry Company, who have occupied rooms in the Alamo Building for several years, will soon move to other quarters.

Pollak Brothers have settled all the claims involved in their failure last summer and have reopened their business. They are fitting up a store at 922 Main street and will move from their old place, 703 Main street.

A sneak thief was caught in a clever manner in this city one day recently. He was an Italian, and gave his name as Rufus Fazio. He entered the jewelry store of W. S. Taylor & Son, 70 Genesee street, and asked to see some diamonds. Clerk G. W. Payne, who stepped forward to wait on him, did not like his appearance, and would not show him the precious stones. He then asked to see some rings, and several trays were placed on the case. Mr. Payne thought he saw him take one, and he turned away, at the same time watching the fellow. He saw him take a ring and stepped to the door to prevent the thief's escape. When accused, the Italian protested, then offered to pay or return the rings. He was taken to the police station and one of the rings was found in his coat sleeve. About his clothing were found, besides the two rings taken from Taylor's, one valued at \$10 from J. Gomp's; three from Kirtland & Gilmore, worth \$16.50; a horse-shoe pin from C. C. Shaver's store, valued at \$4; half a dozen plated spoons, a child's knife, fork and spoon from Sherwood & Golden's, worth \$4. None of the dealers were aware of their loss until asked to identify the goods. Fazio is a slick rascal, and the local jewelers are grateful to Mr. Payne for having brought him to grief. Fazio was sentenced to a year at Albany, and the payment of a fine of \$50.

In New York State.

In the fire which destroyed \$75,000 worth of property in the business portion of Caledonia, N. Y., Feb. 6, J. Simpson, lost \$100 in stock; no insurance.

The Manhattan Silver Plate Co., at Lyons, N. Y., disbursed \$30,000 in wages during 1890, paid a dividend of 7½ per cent., and used 7½ per cent. more of net earnings to enlarge the business.

John W. Greene, of Morrison & Greene, Newburgh, N. Y., on Feb. 3, died of consumption at the age of about seventy-five years. Deceased formerly belonged to Newburgh's crack military organization, the 10th Separate Company. He was unmarried.

JEANNOT & SHIEBLER

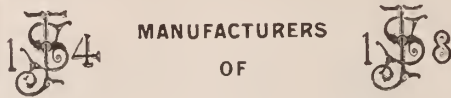

MANUFACTURERS OF

Fine Gold Watch Cases.

No. 20 MAIDEN LANE,
New York.

Constantly on hand, 14k. and 18k. Cases to fit any Movements in the Market.

GEO. W. SHIEBLER,

SILVERSMITH.



Artistic Novelties.

HOLLOW AND FLAT WARE.

Sterling Silver

No. 8 Liberty Place,
NEW YORK.

Essex Watch Case

COMPANY,

T. B. HAGSTOZ, President.



TRADE MARK

6 Maiden Lane, N. Y.

FACTORY,
NEWARK, N. J.

GOLD FILLED CASES.

W. E. W. & CO.

Manufacturing Jewelers,

54 PAGE ST., PROVIDENCE, R. I.



OUR FINE Line of Gold Goods this season includes Bead Necks in ten and fourteen carat, Scarf Pins, Drops; Jersey Pins, Dress Sets, Rings and Bracelets, Band Bracelets in Plate, and the celebrated *POMHAM* Collar Button. To these has been added a full line of White Stone Goods in Gold for the Spring Trade. It should be remembered that OUR GOLD BEAD NECKS ARE THE **LIGHTEST MADE.** Ask to see them.

SELL TO JOBBERS ONLY.

W. E. WHITE & Co.

NEW YORK OFFICE, 26 MAIDEN LANE.

S. A. BALDWIN.

IMPORTERS OF

DIAMONDS.

KOCH & DREYFUS,

22 John Street, New York.

JOBBERS OF

Watches and Jewelry.

REPRESENTED ON THE ROAD BY

EMIL SCHORBACH, GEORGE MALLET,

HENRY HEYMAN, LEO GOLDSMITH.

The Cord and Tension Pulley.

THE cord which transmits motion from the fly-wheel to the pulley of the distributor is always at the same tension. But the cord that passes from the pulley to the lathe must be tight or slack, according to the dimensions and weight, etc., of the work in hand. Moreover, if the ferrule be not fixed concentric with the object that is being turned, or if the pulley be not true on its axes, the cord will be liable to hold and to slip alternately. This inconvenience can be avoided, and the tension of the cord maintained constant and sufficient by using the tension pulley.

Another inconvenience is often occasioned by the unskillful joining of the catgut band. In delicate turning with the hand or foot-wheel it is important that no jerk should be communicated to the work when the joint in the band passes over the ferrule or the pulley of the mandril. Such a jerk can only be avoided, moreover by a carefully-made joint. Several methods are adopted; for bands of large and medium size it is best to use the steel hook and eye screwed on to the ends of the band, these ends being first tapered with a knife and their ends burnt with a hot wire to cause an expansion that will prevent their drawing away from the screw. But such attachments cannot be used with bands under one-sixteenth of one inch in diameter, and one of the following must therefore be resorted to.

1. The most expeditious is a simple knot, and the weavers' knot is by far the best, as it permits of the ends being cut off close, and stands out to nearly the same distance all around the cord. The watchmaker in making this knot, need only observe that the lower portion, representing the length of the band, must be somewhat shorter than is ultimately required, and the knot is to be tightened by drawing the two free ends, while the first point at which the cord crosses is held between the thumb and first finger. The ends must be cut off nearly to the knot, when slightly singed, to cause their expansion, and the knot rolled between the finger and thumb with a little beeswax.

2. The ends may often be spliced together, and although this occupies more time, it has the advantage of producing a gradual increase and decrease of thickness, so that all jerk is reduced to a minimum. The following method is given by Holtzapffel. Having stretched the band, measure off a length greater than is required for the lathe and make transverse holes through the cat-gut at two points rather nearer together than the measure of the lathe (to allow for further stretching). Pass each end through the hole in the other and draw tight; pierce two more holes at right angles to the first and just above them, again passing the ends through from opposite sides of the band. Unravel the full ends, cut away about one-fourth of their substance by a sloping cut from the inner side next the splice. Re-twist and again pass the ends through holes transverse to the last and pull tight. If these instructions are followed, no trouble will be given by the band.

DIAMONDS.

Wm. S. Hedges & Co.,
Importers of Diamonds,

And Manufacturers of DIAMOND JEWELRY.
 No. 170 BROADWAY,
 S. E. Cor. Maiden Lane, New York.
27 Holborn Viaduct, London.

WILLIAM B. DURGIN

Designer and Maker of Wares in

STERLING · SILVER

SPECIALTY OF

Plain and Fancy Flatware

CONCORD, N. H.

MOORE & HORTON,
MANUFACTURERS OF

SOLID GOLD JEWELRY,
 No. 11 Maiden Lane, New York.

Fine Imitation Diamond Goods a Specialty.
 Selection Packages sent on Application.

HENRY FERRA,

Importer of DIAMONDS and

DIAMOND BORTZ.

Diamond Cutting and Polishing Establishment,

10 MAIDEN LANE, NEW YORK.

ESTABLISHED 1834.

G. & S. OWEN & CO.

MAKERS OF

FINE JEWELRY,

Lace Pins, Ear Rings, Scarf Pins, Sleeve Buttons, Sash Pins, Collar Buttons, Bracelets, Studs.

All Goods sold by us are exclusively of our own manufacture and are warranted 14 K. Fine, and stamped as such when possible.

No. 3 MAIDEN LANE, NEW YORK.



ONE OF THE OLDEST RESTAURANTS
 DOWN TOWN.

POPULAR PRICES.

Repeat this operation several times, gradually reducing the thickness of the end until the very fine ends, after passing through their holes, may be cut off close. Hammer gently the finished splice all over; indeed hammering may be resorted to at intervals during the splicing to secure an even surface.

3. A simple substitute for the hook and eye and one that is sufficient in the case of fine bands not subjected to severe tension, may be made by twisting a fine steel wire into a close spiral, rather less in internal diameter than the band, and about half an inch long. It must be hardened and tempered blue. Slightly taper each end of the band, and screw first one end and then the other, each half way into the spiral, taking care before screwing the second end to put a sufficient amount of inverse twist into the band itself. The direction of the spiral must be such that the catgut does not unravel in screwing, and the strength of the joint may be increased by carefully heating the coil to expand the ends of the band.

FILLMORE, N. Y., February 4, 1891.

I do not want to miss a single number of THE CIRCULAR. W. S. MILLS.

Detroit.

The family of Charles W. Grube will go to Europe in June for an extended visit. They will spend a greater part in Germany, where the young ladies will receive tuition in the German tongue.

Royce, Allen & Co. lost none of their books or accounts, but everything in the office was wet blackened and damaged. They estimate their loss at not less than \$19,000, which is covered by an insurance of \$17,000 on stock and fixtures. D. F. Adams' loss was largely caused by smoke and will perhaps be \$1,500 or \$2,000. His stock was insured for \$10,000.

Ralph Dewey, for nine years past connected with the firm of Frank J. Smith, Sons & Co., has tendered his resignation, to take effect April 1st. Mr. Dewey started work for the firm as errand boy and has steadily risen until for several years he has held the position of buyer of sterling silver and art goods for the house. His resignation is the result of a very flattering offer, which he has accepted, of a position in the Paris house of Spaulding & Co., of Chicago.

Pacific Coast Notes.

E. R. Tutt, of Lompoc, Cal., has taken the agency for Jordan's A. A. A. cutlery.

George Reber of Selma, Cal., will sell out his stock and enter the watch club business.

A big reduction sale is being made by J. A. Barclay, of 846 Fifth street, San Diego, Cal.

Frank & Co., of Carson, Nev., have removed from the Arlington House to Carson street.

Klune & Floberg, of Sacramento, Cal., have accepted the Rockford Watch Co.'s agency.

Frish Brothers, the Seattle jewelers, of 720 Front street, have commenced manufacturing fine goods.

The leading Nevada House, Chatelain & Golden, of Virginia City, do an enormous out-of-town business, sending goods on approval by express.

Hanson Bros. & Co., the jewelers and silversmiths, of Tacoma, Wash., possess the largest store in the Northwest. They have recently accepted the State agency for a New York piano house.

The Patent O. F. Cases have these Advantages over the Regular Case: They are Dust Proof and Decidedly Cheaper.

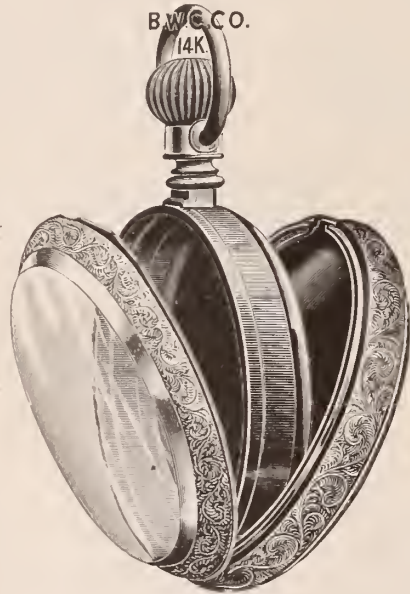

EXAMINE THIS

NOVELTY IN 14-K.

THE BROOKLYN WATCH CASE CO.

192 Broadway, New York,

HAVE IN STOCK AND FOR SALE BY ALL JOBBERS

❖ 14-K. Brooklyn Eagle Wheat and Granger ❖

GOLD CASES IN 18, 16, 6, 14 AND 0 SIZES ADAPTED TO ALL MOVEMENTS OF THE ELGIN MODEL.

The Highest Grade
— OF —
Electro Silver
Plated Ware

Is Stamped with the
 **ROGERS TRADE-MARKS.**
MANUFACTURED BY
The Wm. Rogers Manufacturing Co.,
P. O. DRAWER 30,
HARTFORD. - CONN.

A. LUDWIG & CO.
SILVERSMITHS,
(TO THE TRADE ONLY.)



247 & 249
CENTRE STREET
TRINKMAN BUILDINGS,
NEW YORK.

A. LUDWIG, for the past 9 years Designer and Superintendent for George W. Shiebler.
SILVER NOVELTIES
A SPECIALTY.
Designs and Estimates Cheerfully Furnished.

(Continued from page 1.)

that the overruling influence of the demi-god Benvenuto Cellini, has given a strained bent to all the efforts of many artists of his time who might otherwise have produced works strongly marked with originality.

We must admire the bold and refined genius of the illustrious Florentine, his energy and his perfect mastery of all the processes of his craft. But we cannot look upon him as the master *par excellence* whom alone we ought to follow. In every one of his works which have been preserved or described, he has almost entirely overlooked fitness, or made it subservient to decoration. His imagination was unbounded and carried him over the most necessary rules of our special art. He has taught us a great deal in the decorative line, but a gold and silversmith must not blindly copy him if he wishes to produce an article that will be useful as well as elegant.

The gold salt-cellar, reproduced in fig. 11, which Cellini made for Francois Premier, and the celebrated ewer, fig. 12, has been described so many times that it is not necessary to repeat the descriptions.

Fig. 13 represents a salt-cellar given towards 1517 by Richard Fox, Bishop of Winchester, to the Corpus Christi college of Oxford. It is in gilt silver and blue enamel, with the exception of the salient part that divides the cup from the stand, which is in red enamel. The lions standing each side of the niches, which contain bas-relief figures, curiously enhance the whole effect. The florid, Gothic character of decoration prevalent all over the piece shows that in the six-



FIG. 12.—AIGUIERE BY CELLINI.

teenth century English artists were still partial to a style then completely abandoned on the continent.

The silver cup shown in fig. 14 is a Nuremberg work of the same period, belonging to the Cluny Museum. The bold shape of the cup and the varied outlines of the stand com-

bine to give it a very striking appearance. It is considered one of the best specimens of the German works in that line of the six-



FIG. 13.—SALT CELLAR IN SILVER, GILT AND ENAMEL.

teenth century. The figures, marks and ornaments are in repoussé.

The Dutch drinking horn in silver, exhibited by fig. 15, is no doubt a very curious piece. It belongs to the Amsterdam Town Hall. The artist who designed it was evidently endowed with a powerful imagination, and possessed besides, a kind of naïve earnestness. The workmanship, especially the chasing, is remarkable. That work of art illustrates in an original style the fight of St. George with the dragon.

A silversmith workshop at the Renaissance time seems to have been a very comfortable place, perfectly suited to its purpose, as you may judge from fig. 16, which is reproduced from a plate engraved by Etienne Delaulne, a Parisian silversmith, who lived in the sixteenth century and who signed all his works by the name of Stephanus. We see there a boy pulling hard at the rolling bench, the same contrivance that was still used some thirty years ago to flatten metals. A tall youth in front of the furnace is occupied with annealing. An intelligent-looking fellow is at work at the bench chasing, and his two companions are variously engaged. Numerous pincers and tools of all kinds arranged in good order on racks, cover the walls. All the details seem to be in the right place, and we can see at a glance that we are introduced into a real workshop of the period.

When Cellini had a gold figure of Christ to execute he made a perfect model of it in wax and copied it in the precious metal. He hammered, to that end, a gold plate of the proper size, leaving it a little thicker in

ings. This is also the case in a remarkable German ewer of the same period, belonging to the Louvre, which he made for Francois Premier, so that during the course of his embossing work he could stretch the metal to the extent required. He then began to fashion it roughly on anvils of various shapes, and through repeated annealing, when the gold became hammer-hardened he obtained with different mallets and wooden tools the gross form of the figure. Having come to that stage he brought out more and more the alto-relievo, though gradually acting on the margins of the metal, closer and closer, only sparing what he wanted to make all the parts meet well at the back. Finally he chased the figure, which he had first filled up with cement then removed the soft substance and soldered the piece.

Yet the Florentine master in gold and silver-smithing learned something from the French, as he has himself acknowledged it in his book. He says that he made use of certain small *bigornes* that Parisian *orfèvres* were accustomed to employ. This means that before he came to France he had never heard of the *ressing* (fig. 17) or snarling tool. If we examine all Italian cups and vases in gold and silver of the sixteenth century which have been preserved, we see that the body of each of these pieces consists of two or more different parts that have been fastened together after being decorated in repoussé. The line of junction is hidden with mould-



FIG. 14.—SILVER CUP—XVI. CENTURY.

to the Louvre collections, and exposed in the *Galerie d'Apollon*, as can be seen by looking at fig. 18. This fine vase exhibits in repoussé a scene full of animation, an episode from the battle fought at Tunis by Emperor Charles V.

(To be continued.)

Chicago.

L. W. Flersheim of the firm of Lapp & Flersheim, will shortly leave for the West in quest of a much-needed rest.

F. L. Smith, treasurer of the C. H. Green Jewelry Company, of Denver, Col., was at the Palmer House recently.

Mortimer V. Burchard, western manager of Simpson, Hall, Miller & Co., is away on a western trip as far as Denver.

T. F. Sheridan, master mechanic of the Illinois Watch Co.'s Works at Springfield, was in town several days the past week.

Jacob Bunn, Jr., New York Manager and Vice-President of the Illinois Watch Co. at Springfield, sailed for Europe, February 7.

W. S. Wilkinson, of W. S. and J. B. Wilkinson, Jewelers, Tray and Case Manufacturers, has returned from a three weeks trip East.

A. E. Bently, of Springfield, Ill., who has been manager of the Illinois Watch Co.'s works, resigned his position on the 4th instant.

J. A. Todd, western manager of the Towle Mfg. Co., with headquarters in this city, is expected back in about two weeks. He is on his way out to the Coast.

A. W. Sprochule, of F. M. Sprochule & Co., and G. M. Weiding, Chicago, representative of Fahy & Co., have gone to New Orleans to attend the Mardi Gras.

E. A. Parker, representing R. Wallace & Sons, of Wallingford, Conn., was in this city to attend the banquet of the Chicago Jewelers' Association and to do some business.

W. J. Miller, President of the Derby Silver Plate Co., of Derby, Conn., and his wife are making a joint pleasure and business tour of the West as far as the coast. They are at present at the Palmer House in this city.

Watson J. Miller, President of the Derby Silver Plate Company, was the first to secure compartments for himself and wife in the new parlor cars that made their initial trip over the Chicago & Alton railroad last Monday morning.

James D. Packard will travel in Illinois and Missouri this year for H. F. Hahn & Co. He takes the place on the road formerly held by M. H. Lebolt, who will remain in the house. Mr. Lebolt was a "hustler," and popular with the Western buyers.

Kind, Abt & Co. have just completed refitting the interior of the store at Madison and Franklin streets. They will begin laying in their stock for the wholesale trade this week. They will make a specialty of hair ornaments this year, which character of personal decoration has come around to its periodical popularity in the West.

There was quite a rush of country dealers to the city last week. For times alleged to be bad, they left large orders. Among them were S. W. Thompson, of Sheldon, Ill.; E. Rosenbaum, of Bushnell, Ill.; E. Kannal, of Renslaer, Ind.; E. W. Blossom, of Sterling, Ill.; M. Lippit, of Cedar Rapids, Ia.; and E. F. Doering, of Waterloo, Wisconsin.

TRADE MARK **J.G.C. & CO.** MARK.

Manufacturers of
FINE
Rolled Plate
CHAINS.

J.G. Creever & Co.

North Attleboro, Mass.

S. COTTLE & CO.,
MAKERS OF
FINE JEWELRY AND SILVER
NOVELTIES,
No. 86o Broadway, NEW YORK.



BOOKS FOR JEWELERS.

W. B. DICKIE,
67 William Street, New York,
PUBLISHER OF
Improved Watch Stock Book
—AND—
Improved Watch Repair Book.

SEND FOR DESCRIPTIVE CIRCULAR.

WOOD & HUGHES,
Sterling Silverware Manufacturers.
New York Agents for the Derby Silver Co.'s
FINE QUADRUPLED PLATED WARE.
No. 16 JOHN STREET, NEW YORK.
206 Kearney St., San Francisco, Cal.
HASKELL & MUEGGE, Agents.

MUSICAL JACOT & SON,
298 Broadway,
New York
Send for Catalogue. **BOXES.**
Musical Boxes Renaired.

TO WHOLESALE DEALERS.
WE HAVE FOR IMPORT
A FINE LINE OF
BLACK FOREST
(SCHWARZWALDER)
CUCKOO CLOCKS,
With Brass Movements in dust-proof cases.
E. R. SCHLENCKER, Manufacturer,
Schwenningen a/ Neckar,
WURTEMBERG, GERMANY.

H. LUDWIG & CO.

MANUFACTURERS OF
NOVELTIES IN JEWELRY
LARGEST MFG. OF
POPULAR PRICE JEWELRY IN U.S.

NEW YORK OFFICE,
PRESCOTT BUILDING,
ROOM 40. SAMPLES ONLY.

WORKS, BLACKSTONE & GAY STS.
TAKE PRAIRIE AVE CAR

Providence, R.I.

Established 1872.
PLAINVILLE STOCK CO.

P. S. CO.

THIS TRADE-MARK REGISTERED, AND STAMPED ON ALL OUR GOODS.

BROOCHES, SCARF PINS, DROPS, SETS.
FACTORY AT PLAINVILLE, MASS. SAMPLES AT 176 BROADWAY, NEW YORK.

HAVE YOU TAKEN YOUR INVENTORY?

HAVE YOU REMEMBERED? —Old gold or silver? If so, —That we pay 4 cents per kt. for gold and highest market price for old silver.

HAVE YOU REMEMBERED? —On hand a collection of old plated jewelry filings, sweeps, etc., or a lot of old jobs, which have been on hand for years, with no likelihood of being called for.

HAVE YOU REMEMBERED? —A lot of old style and unsalable jewelry on hand? If so, it would be good policy to dispose of same, convert the proceeds into an article that you would probably turn over several times, besides give your stock a nice, clean appearance.

OUR PLAN —Immediately on receipt of shipment, we will remit by cash or draft (as desired). If our offer should not prove satisfactory, we will return consignment in exactly same condition as received and pay all charges. By this arrangement you are absolutely safe, as it is no sale unless our offer should prove satisfactory, and you run no more chances than if you were disposing of same right over your counter. —Send for our little book giving pointers on testing and buying gold and silver. Mailed free on application.

GOLDSMITH BROS.

Gold and Silver Refiners and Assayers,
63 & 65 WASHINGTON ST., CHICAGO, ILL.

Columbus, Ga., Jan. 10, 1891.
Dear Sirs: Yours of the 7th inst. to hand, containing check for \$29.88. All satisfactory. Accept thanks.
Yours truly,
C. M. KINSEL.

Denison, Tex., Jan. 6, 1891.
Goldsmith Bros., Chicago, Ill.
Gents: Your draft of Jan. 3, '91, came to hand this day. Amount very satisfactory, (\$112.93).
Very Respectfully,
B. W. MERRILL.

Los Angeles, Cal., Jan. 6, 1891.
Messrs. Goldsmith Bros., Chicago, Ill.
Gentlemen: Your favor duly to hand, containing check for \$176.64, which is satisfactory to us.
Yours,
J. F. GRANAS & CO.

Little Falls, N. Y., Jan. 12, 1891.
Dear Sirs: Your favor of Jan. 9 received, which is satisfactory. Respectfully,
ANDERSON & HOUGHTON.

Keokuk, Iowa, Jan. 3, 1891.
Gentlemen: Accept thanks for check for \$153.58 in settlement for old silver.
Yours Resp'y,
T. R. J. AYRES & SONS.

Decatur, Ill., Jan. 19, 1891.
The check for \$65.45 is all satisfactory.
O. E. CURTIS & BRO.

4 Centre Ave., Pittsburgh, Pa.
Gentlemen: \$54.32 received for old gold. Thanks. Am satisfied beyond expectation.
Respectfully,
H SCHEINEMAN.

Milwaukee, Wis. Jan. 23, 1891.
Gents: Your favor of yesterday, inclosing check for \$205.80, to hand, which is very satisfactory.
Yours truly,
C. PREUSSER JEWELRY CO.

St. Cloud, Minn., Jan. 2, 1891.
Gents: Your check of \$12.00 is very satisfactory, more than we expected to get. Many thanks.
Respectfully,
GEO. R. CLARK & CO.

Moberly, Mo., January 2, 1891.
Goldsmith Bros.
Gents: Your express order for old gold received. Same satisfactory. I get a great deal of old gold and silver, and have sold same in New York and Philadelphia, but have never received what I thought full value until I commenced sending to you. This is my ninth shipment to you.
Respectfully,
A. F. SEELEN

THE Trade are cordially invited, when visiting New York, to call at our Office, No. 30 Union Square, and inspect our line of samples for the Spring Season.

Our MR. FRANK MAUSER will soon call on you with a full line.



E. R. STOCKWELL,
19 JOHN ST., NEW YORK,
MANUFACTURER OF

Badges and Medals in Gold and Silver,
FOR ALL SOCIETIES,

INCLUDING
MASONIC,
ODD FELLOWS,
GRAND ARMY
ALSO FOR SCHOOLS.

» BUTTON BADGES IN SILVER OR GOLD. »
ENAMELING AND REPAIRING FOR THE TRADE.

FALKENAU, OPPENHEIMER & CO.,



40 MAIDEN LANE, NEW YORK.

P. O. BOX 3314.

B. & W. B. SMITH,

220 West 29th Street, New York City.

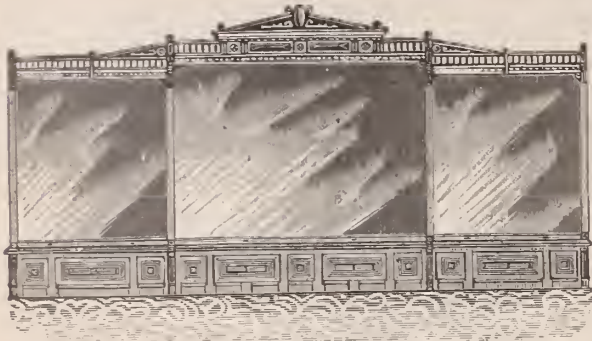

WALL CASES with Perpendicular Sliding Sash—Dust Tight—with our Improved System of Shelving for Silverware and other Goods.

ATTENTION.

We make Cases and have them on exhibition at our factory, of any size and shape of plate glass and with wood moulding, as small as an eighth of an inch in diameter.

Catalogue of Illustrations Issued.

CALL AND SEE US. ♦ ♦ ♦ ♦

♦ ♦ ♦ ♦ CORRESPONDENCE SOLICITED.

WE MAKE TO ORDER ONLY.

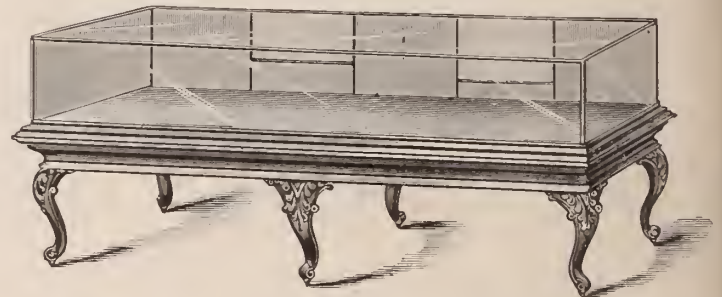

COUNTER CASES with our Dust Tight, Perpendicular Sliding Doors. Any Hardwood and Imported Plate Glass. Table or Counter with adjustable jack for any uneven surface.

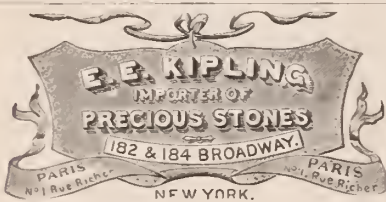

S. P. HOWARD,
Gold and Silver Assayer,
Refiner and Sweep Smelter,
8 & 13 JOHN STREET, NEW YORK.
Smelting and Refining Works,
28.30 & 32 Cumberland St., Brooklyn, N. Y.
Specialties: Sweetenings, Gold, Silver and Platinum.

THE ROGERS & HAMILTON CO.,
WATERBURY, CONN.
MANUFACTURERS OF

Highest Grade Electro-Plated Flat Ware.
SEND FOR PRICE LIST.

ESTABLISHED 1837.

TAYLOR & BROTHER,

Old House READ, TAYLOR & CO.,
IMPORTERS OF

Diamonds and Pearls

AND
Manufacturers of Diamond Jewelry,

860 BROADWAY, NEW YORK.

Branch Office, 1 1/2 Maiden Lane.

21 HOLBORN VIADUCT,
LONDON.

206 KEARNEY ST.
SAN FRANCISCO.

S. F. MYERS & CO., Wholesale Jewelers.

EVERYTHING
THAT
PERTAINS
TO THE
JEWELRY TRADE.
22
DEPARTMENTS.



WE REQUIRE
AND OCCUPY THE
LARGEST
SALESROOMS
IN OUR LINE.
4 STORES.
GROUND FLOOR.

48 & 50 Maiden Lane and 33 & 35 Liberty Street, New York.
CONSULT OUR MAMMOTH CATALOGUES.

A. N. CLARK, PLAINVILLE, CONN. } MANUFACTURER of the Celebrated
LOOP WATCH KEY.

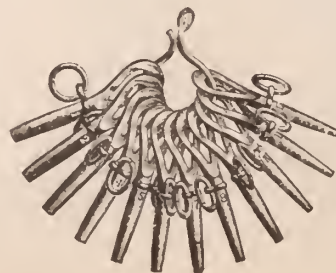

The best for the price in the World. Size of Square stamped on each Key.

Also Key Rings, Watch Case Springs, Jewelry Tools, Tweezers, Etc.

SEND FOR PRICE LIST.

SOLD BY ALL JOBBERS IN THE LINE AT MANUFACTURER'S PRICES.



Entered at the Post Office in New York as second-class matter.

VOL. XXII.

NEW YORK, WEDNESDAY, FEBRUARY 25, 1891.

No. 4.

MAIDEN LANE FORTY YEARS AGO.

THE year 1849 is not yet so far behind us but that many men who would scorn to be called old, have vivid mental pictures of that time. To Maiden Lane, as to many other streets in this city, have come changes since that time; and while, perhaps, not so many buildings that were located along her sidewalks have felt the ravages of

traveling jewelry salesman unpacked his grip and prepared to catch the jobber. H. H. Chapman, who sold shirts, was also in this building, as was the old firm of Crouch & Fitzgerald, of trunk fame.

Wm. H. Jacobs, who catered to the clothing demand, occupied No. 3, and with him were E. Philippoteaux, importer of baskets,

same building one could purchase hosiery from W. & J. Morrison, fancy hardware from Wm. G. Miller, and fancy goods from Read, Taylor & Co.

No. 11, the last building shown in the cut, held Fellows, Van Arsdale & Cooper, importers, and R. & A. Lane, dealers in dry goods.

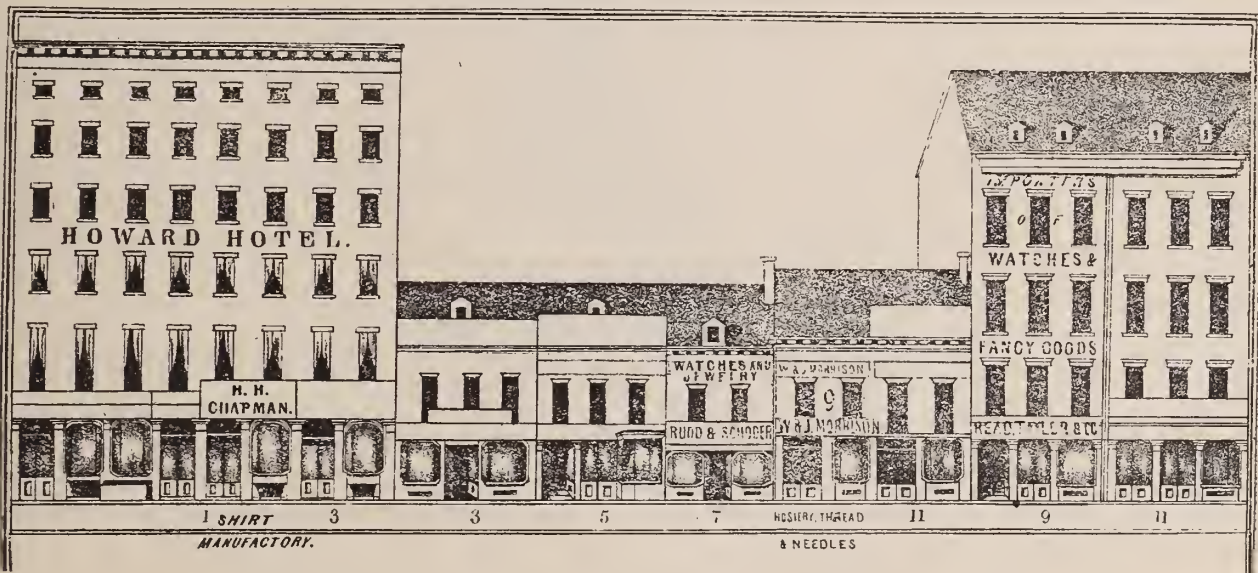

those enterprising owners who are continually tearing down old houses for the purpose of building new ones, still the face of the street presents features different from those of forty years ago. Our cut represents a section of Maiden Lane, just as it appeared to the passer-by of the year 1849. It is taken from an old lithograph of that year, and is exact and true.

At No. 1 was the old Howard Hotel, remembered as the place where jewelers met for social and trade purposes, and where the

W. H. Smith & Co., who kept knives, forks, spoons and such other things as were then gathered under the head of "hardware," and B. M. Seixas who supplied smokers with fragrant havanas.

No. 5 held only Draper & Rowland, who dealt in fancy goods. Rudd & Scudder's, at No. 7, was the first jewelry house to be met on that side of the Lane as one passed down from Broadway.

Next door to them, at No. 9, was another jewelry firm, D. Colton, Jr. & Co. In the

Most of these merchants have passed away now, and their contemporaries speak of them as "old fellows." Orlando Fish, who kept the hotel, afterward kept a boarding house on Broadway. Fitzgerald, who was one of Beecher's deacons, died peacefully in the quiet city over the river. Joseph Rudd, of Rudd & Scudder, became wealthy before he died, while Scudder was not so fortunate. Joseph M. Cooper, of Fellows, Van Arsdale & Cooper, afterward became president of the Chatham National Bank.

The Toledo Club's Second Annual Banquet.

Jewelers and Their Guests Have a Pleasant Dinner. Personal Reminiscences the Subject of the Post-Prandial Speeches.

THE Second Annual Banquet of the Toledo Jewelers' Club was held in the Boody House, Toledo, on the evening of Tuesday, February 17th. The affair was attended by fifty persons. They were the members of the club, some of their employes and a few visiting friends.

The banquet table was in the form of a "T," the initial letter in the club's name. The hall decorations were beautiful, narcissus appearing in profusion. At 9.30 o'clock the banqueters seated themselves with President J. G. Kapp in the place of honor. Those present were:

Nat Wolff, with Veit, Hirsch & Co., New York; John Schweikert, with E. & J. Schweikert, Cincinnati; William H. Broer, Geo. U. Roulet, J. J. Freeman, B. H. Broer, Chas. B. Bargman, William F. Kapp, Geo. W. Schorbach, J. J. Harbauer, William Walcott, J. Sherman, C. P. Eells, J. W. Flowers, Edward Armstrong, J. G. Kapp, G. M. Baker, Edward J. Hirssig, Jacob Frame, John Kapp, M. Judd, F. G. Roulet, Fred. Happersberger, E. J. Tippet, Charles C. Kapp, Edward J. Ley, N. E. Hascall, S. A. Leopold, M. F. Kratt, H. D. Breadt, W. E. Clemens, Louis Commloussy, F. C. Wade, M. F. Hechler, M. N. Kinnay, John A. Camenzind, H. C. Weis, F. Fagate, A. Pflueger, J. Cooper and Geo. W. Stevens.

The twelve courses finished, the banqueters lit their cigars, and leaning back in their chairs listened to the members of the club while each related the circumstances surrounding their entrance into the jeweler's business. This programme had been arranged to take the place of the usual toasts. The president, after a few words of welcome called on the different members of the club, who related in an interesting manner, the history of their connection with the trade, each beginning with the reason why he entered it.

Before breaking up the jewelers were re-

quested to show their watches, and there wasn't one in the gathering who carried a watch worth over \$15. Three or four carried Waterburys. One had a tin watch and the three or four who carried gold ones finally acknowledged that they did not belong to the wearers. So ended a most happy evening.

A New Swindling Dodge.

A SHARP woman struck Louisville, Ky., recently, and the result of her visit has taught jewelers and pawn-brokers a few points of law. She had a pair of handsome earrings, which she was anxious to pawn. They were of a beautiful white, first-water color, and a number of pawnbrokers and diamond dealers pronounced them genuine and worth \$500. The woman wanted \$600 for them. She was such a lady in appearance and manner and was so anxious to furnish a flat and go to housekeeping, and hated so to part from her earrings which her husband had given her just a few weeks before, that she made a favorable impression on the trade. Finally she worked them off on a diamond expert for \$500. She pocketed her money and departed. On the next morning, a detective was looking for a slick female named Kate King, from Cincinnati, who had been "working" a number of Southern Indiana towns, assisted by a pickpocket friend who passed as her husband. The detective had learned that Katie made a business of taking inferior diamonds and painting them a beautiful white, thus turning them into "first-water" stones. When he stepped into Haissmann's pawn-shop, on Market street, and asked concerning the engaging Katie, describing her and her business, Heissmann almost dropped dead. He threw up his hands and exclaimed "She's got me sure." He ran to the safe and took out his purchase, dipped them into some hot water rubbed them with his handkerchief and there they were, as blue as the sky and worth about \$200. He set about having the adventuress arrested, and in an hour or so

she was behind the bars. She was brought to court the next day on a charge of obtaining money by false pretenses. Able lawyers were engaged for and against her, and the above facts were brought out in the evidence. After the testimony was all in the judge who was trying the case, said:

"I believe this woman is a sharper and ought to be punished, and I am sorry the law applicable in this case will not permit it. She is technically innocent of this charge and must be discharged. Had she passed off another kind of thing entirely as a diamond then she would be guilty. But it is conceded that the stones she sold were actual diamonds. The only question was one of valuation, and the merchant who bought them is presumed to know his business. If she had taken \$50 worth of diamonds and sold them for \$1,000, as diamonds, she is technically not guilty."

The decision was borne out by copious readings from the decisions of various State courts, including those of New York, Massachusetts, Connecticut, Rhode Island, Pennsylvania, etc. The jewelers of Louisville will not soon forget the handsome Mrs. King and her white diamonds, nor the law applicable in such cases.

To Polish Steel.

TAKE crocus of tin oxide and graduate it in the same way as in preparing diamond dust, and apply it to the steel by means of a piece of soft iron or bell metal made in proper shape, and prepared with flour of emery, the same as for pivot burnishing. Use the coarsest of the crocus first, and finish off with the finest. To iron or steel a better finish can be given by burnishing than can be imparted by the use of polishing powders of any kind whatever. The German method of polishing steel is performed by the use of crocus on a buff wheel. Nothing can surpass the beauty imparted to steel or even iron by this process.

IMPORTERS OF

DIAMONDS.

KOCH & DREYFUS,

22 John Street, New York.

JOBBERS OF

Watches and Jewelry.

REPRESENTED ON THE ROAD BY

EMIL SCHORBACH, GEORGE MALLET,

HENRY HEYMAN, LEO GOLDSMITH.



ROGERS & BRO. A-1.

HOLLOW WARE.

OLDEST BRAND AND HIGHEST GRADE OF

ELECTRO SILVER PLATE.

ROGERS & BROTHER, Manufacturers,

16 Cortlandt Street, New York.

Waterbury, Conn.



Photograph Albums and Price Lists upon Application accompanied by Business Card.

TRADE
SEAMLESS
 MARK.
GOLD · FILLED · CHAINS.

ON ACCOUNT OF

THE great popularity of the chains made exclusively by us for the past three years, the air has been FILLED and the paper of the various Jewelers' Journals COVERED with the word "SEAMLESS" which has been and is our trade mark.

We never had such a boom in our business as we have had since our friends commenced to advertise our goods.

We have only a word to add, and that is we make and sell the

ORIGINAL AND GENUINE

SEAMLESS GOLD FILLED CHAINS.

In addition to the word SEAMLESS and for the protection of our customers we place upon each Chain a tag bearing the following trade-mark :



Which is affixed by authority of its owners, as a guarantee that the Chains are made from the Burdon Seamless Filled Wire.

BOSTON OFFICE,

6 WINTER STREET,

In charge of

I. W. STELLE.

NEW YORK OFFICE,

17 Maiden Lane.

PACIFIC COAST AGENCY,

WM. E. PETTES & Co.,

PHELAN BUILDING,

SAN FRANCISCO, CAL.

Address all communications to

KENT & STANLEY,

PROVIDENCE, R. I.

James M. Bolton Guilty.

The Story of a Clerk Whose First Offence Forced Him into Many Others.

LAST Wednesday Joseph M. Bolton was tried in the General Sessions before Recorder Smyth, upon an indictment charging him with grand larceny in the second degree, in stealing in November, 1889, from the Gorham Manufacturing Company, sterling silverware to the value of \$500, and of receiving stolen goods. Bolton moved in good social circles, and was a member of the Seventh Regiment. For years he had been known as a man about town, leading a very gay life. Richard Pennell, an employee of the Gorham Manufacturing Company and George A. Williams were jointly indicted with Bolton. The latter two pleaded guilty, Pennell under the name of Richard Pendleton. They were then called as witnesses for the people.

Pennell, youthful and prepossessing in appearance, testified that he had been a salesman in the store of the Gorham Manufacturing Company. He had frequently met Bolton in various public places and an acquaintance had sprung up between them. In November, 1889, Bolton called upon him at the store, Nineteenth street and Broadway, and selecting a silver ring, said he would pay for it in a day or two; and in the same month a year later, he called and said he wanted a ring and a watch and chain valued at \$35. Pennell told him he had not paid for the first ring, and upon his refusal to let him have more goods on credit, Bolton threatened him with an exposure of the first transaction. Pennell then gave him the articles he wanted.

From this time on, Pennell connived with Bolton to pilfer goods from the company. He stole silver flatware to the value of \$500, which he handed over to Bolton, who said he could sell the articles to a fence through a third party. The proceeds of the sale Bolton told Pennell later, were only \$60. Of this he gave Pennell \$30 but received \$10 for expenses of a trip to Philadelphia where the "third party" lived. Bolton then demanded more silver but Pennell refused.

About a week later George A. Williams, a friend of Bolton's, stopped Pennell on Broadway and informed him he was the "third party;" he demanded some silverware from him, threatening him with exposure if he refused. Pennell was therefore forced to steal about \$1,500 worth more of silverware and

turn it over to Williams, who gave him \$200. When Pennell was arrested last month, he confessed his crime.

Williams corroborated Pennell in all the details of the story. John Bones, a clerk for Carver Reed, a pawnbroker of Philadelphia, identified Bolton and Williams as the men who on three occasions in November last pledged silver.

Bolton, in his own behalf, testified that he did not get the rings in November, 1889. He said Pennell wanted him to credit the value of them upon an account of \$25 which was due his (Bolton's) father who is a well-known Broadway tailor. The value, however, he said he credited to a debt of \$25, money which he had loaned Pennell.

The jury retired at 7 o'clock in the evening and at midnight they reported that they could not agree. They stood nine for conviction of grand larceny in the second degree, and three for acquittal. They were locked up for the night, and at 11 o'clock on Thursday morning they returned to the court room, having found Bolton guilty of receiving stolen goods. They recommended him to the mercy of the court. Recorder Smyth remanded the prisoner for sentence until Tuesday, and Bolton went back to the Tombs. The recommendation to mercy may send him to the Elmira Reformatory instead of to State Prison. The incarceration will be from two to five years.

Pennell and Williams will be tried after Bolton is sentenced.

Romeo, Mich., Feb. 16, 1891.

Don't fail to send the first number of "The Circular." I think it fills the bill as a trade journal.

C. N. Coe.

Another Watch Club Arrest.

W. E. CAWOOD, formerly at No. 227 Summit street, Toledo, O., was arrested recently on the charge of conducting a lottery. Mr. Cawood started a watch club of sixty-five members, each one paying \$1.00 for the privilege of drawing. The first winner took his watch and dropped out, the second likewise, and so on until the last one had drawn a watch. Thus the first man paid \$1.00 for his watch and the last \$65.00.

Mr. Cawood when on trial said he had no intention of violating the law and was fined \$25.00. He now has a watch club of thirty-five members, each member of which pays \$1.00 at each drawing.

Folding Pocket Opera Glass.

THE novelty herewith illustrated which is intended for gentlemen can be folded up into cylindrical form and carried in the pocket. The handles are first drawn



out and then pressed down, when the glass is ready for use, as in fig. 2. It has its

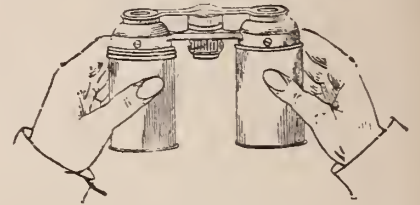

advantages on account of the small compass into which it can be compressed and the ease of adjustment. The novelty originated in Paris, and the exclusive American agents are M. Zineman & Bro., the busy opticians, 130 South Ninth street, Philadelphia.

Stole Two Pairs of Bracelets.

ON Thursday morning last William H. Clegg was arraigned at the tombs before Justice Hogan on the charge of larceny of two pairs of earrings from Chas. S. Crossman & Co., No. 23 Maiden Lane.

Mr. Crossman in his complaint stated that on August 7, last, the defendant looked over a quantity of earrings at the firm's store and left without buying anything. Subsequently he was notified by Detective John Kearney, of Brooklyn, that Clegg had been arrested in the act of pawning two pairs of earrings, and that Crossman & Co.'s business card was found upon the prisoner. The prisoner pleaded not guilty and Justice Hogan held him for examination at 2.30, Feb. 24.

On the day he was arrested he had just been released from the King's County Penitentiary where he had served a six months' sentence for stealing a pair of gold sleeve buttons.

Butler, Mo., Feb. 16, 1891.

If you keep THE CIRCULAR up to its present standard it will be of great benefit to the retail trade and to the workmen.

N. B. Jeter.

ESTABLISHED 1837.

TAYLOR & BROTHER,

Old House READ, TAYLOR & CO.,

IMPORTERS OF

Diamonds and Pearls

AND

Manufacturers of Diamond Jewelry,

860 BROADWAY, NEW YORK.

Branch Office, 1 1/2 Maiden Lane.

21 HOLBORN VIADUCT,
LONDON

206 KEARNEY ST.
SAN FRANCISCO.

A. N. CLARK, PLAINVILLE, CONN.

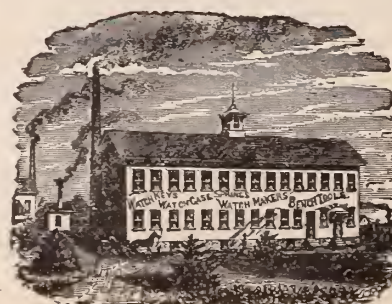

MANUFACTURER of the Celebrated

LOOP WATCH KEY.

The best for the price in the World. Size of Square stamped on each Key.

Also Key Rings, Watch Case Springs, Jewelry Tools, Tweezers, Etc.

SEND FOR PRICE LIST.

✶ SOLD BY ALL JOBBERS IN THE LINE AT MANUFACTURER'S PRICES.

THE PAIRPOINT MFG. CO.
New Bedford, Mass.

FINE

* **GOLD** *

AND

SILVER

Plated Ware.



No. 110. COFFEE SET.

OUR LARGE LINE
OF
STAPLES
AND
NOVELTIES

WILL BEAR INSPECTION.

Quality
Guaranteed.

NEW YORK.

CHICAGO.

SAN FRANCISCO.

FOR CLEANING AND POLISHING.

THE LATEST AND THE BEST
POLISH
FOR
SILVER GOLD, NICKEL
AND GLASS.



WILL NOT SCRATCH
THE
FINEST SURFACE.

EVERY RETAILER OUGHT TO HAVE IT IN STOCK.

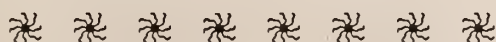

DAVID F. CONOVER & CO.

PHILADELPHIA, - - - - - PENN.

Queries and Answers.

Polish, Pivots and Jewels.

SALEM, MASS., Feb. 18th, 1891.

To the Editor of the *Jewelers' Circular*:

Will you tell me how to prepare a good liquid polish for silverware, plate glass, etc.? Also the best way to polish a conical balance pivot or how to finish and temper a new pivot.

How can I judge accurately the right size of a roller jewel to fit in slot of the fork?

I often set one that will go into the hole in the table readily, but I find later on that it will not run, as it is too large.

A LADY.

Four parts of washed pipe-clay and one of purified tartar, intimately mixed, may be made into a liquid polish by adding water. The best agents for cleaning silverware are all substances which come under the head of carbonates of lime, such as precipitated, not prepared, chalk, burned hartshorn, etc. Precipitated chalk when in an impalpable powder mixed with water will make a fluid which will instantly remove tarnish from silver or plated-ware without scratching the most highly-polished surfaces.

A conical pivot may be polished either by a properly-shaped burnishing file and a Swiss

Jacot tool or in the turns by using red stuff and a brass polisher, filed round on one side and conical toward the point.

A new pivot is made of hardened and tempered steel before it is inserted in the staff, and is finished like any new pivot by the graver, and exactly like a conical pivot with the exception of the forming of the polisher; which must be filed flat and square and must be of soft steel or iron instead of brass.

A roller-jewel or a jewel-pin must be fitted in the slot of the fork and not in the roller, and must enter the slot easily without any perceptible side shake. It is of no material consequence that the jewel-pin enter loosely into the hole of the roller, as the shellac with which the jewel is fastened will fill a small vacant space.

The shellac with which the jewel is to be fastened should be applied in the shape of a thin drawn stick about the thickness of an ordinary sewing needle, which will prevent too large a quantity flowing at a time.

Pittsburgh, Pa.

Nearly all of the jobbers have started their traveling men upon the road.

Heeren Bros. & Co., have been obliged to engage another man to assist in their optical department.

Myer Gallinger, doing business as N. Gallinger, is closing out his store located at No. 1200 Pennsylvania avenue, at special sale.

H. U. Seaman, has opened a place in the Standard Building on Wood street for the handling of watchmakers' materials and supplies.

Weibert Haeckler, at No. 3545 Butler street, who has one of the oldest stands in this city, is selling out his stock at auction. He will retire from business.

Edward W. Hill, of the firm of Goddard Hill, & Co., was married on Wednesday evening to Miss Templeton, of Allegheny. They will be gone about ten days on a trip to eastern points.

G. B. Barrett, of G. B. Barrett & Co., denies that he will remove from his present location No. 101 Fifth avenue. An item in one of the daily papers announced that the entire building had been leased to other parties.

Heckel, Bieler & Co., will remove about March 1st from their present quarters to the corner of Wood and Smithfield streets, over the B. & O. ticket office. The stand is located in the center of the city and is of easy access to and from all points.

Cleaning a Watch.

Whatever system of cleaning is adopted, it is essential that it be concluded by passing a pegwood point into each of the holes. Brilliancy is given to the surfaces of cleansed pieces by passing a carefully-kept fine brush over them.

The R. Wallace & Sons Mfg. Co.,



No. 230 CUP. IN STERLING SILVER, TWO-THIRDS SIZE.

MANUFACTURERS OF

Sterling Silver, Plated Ware & Fine Cutlery

FACTORIES, WALLINGFORD, CONN.

{ New York Store: 3 Park Place.
Chicago Store: 104 State Street.



Easy Lessons for Opticians.

BY C. A. BUCKLIN, A.M.

THE cornea, owing to the fact that it is the most frequent seat of visual obscurities, and the deformities of which cause all the regular forms of astigmatism, becomes a subject worthy of the closest consideration by those who follow the calling of an optician.

The cornea is of about the same transparency as glass. It is composed of five layers. The first layer is composed of several layers of epithelium which are placed upon a basement membrane bearing the name of its discoverer, Bowman; next is the true substance of the cornea, which is a cell structure; next, the membrane of decernet; and last, the endothelial layer of cells. These anatomical divisions are of practical importance in reaching a clear understanding of the obscurities of the cornea which make it impossible or impracticable to adjust lenses which shall prove satisfactory. Thus injuries to the cornea which only involve the epithelial layer, are always repaired by nature without leaving a scar behind to act as a future visual obscurity.

Obscurities which result from inflammatory products which are thrown out in the corneal cells producing an obscurity appearing like a milky agate, under judicious treatment usually absorb so perfectly that no visual obscurity is left behind. Losses of the substance of the cornea resulting from injury or from ulceration, are followed by a cloudy opacity of the nature of a scar.

Obscurities of the cornea which are of long standing and which are not accompanied by any irritation of the eye are generally permanent. The most frequent obscurity met with in the cornea is called *pannus*. The cornea appears cloudy and fine blood vessels shoot out over its surface. This trouble is caused by granular eyelids. In old cases it frequently leaves a permanent obscurity which is little benefited by treatment. In cases where there are still symptoms of irritation about the eyes, proper treatment of the granular eyelids will frequently bring about a satisfactory improvement in vision. As the result of orbital neuralgia, which in this vicinity is almost without exception of a malarial origin, we have a corneal obscurity produced which is rapidly and perfectly removed by the administration of quinine.

Obscurities occurring in the cells of the cornea, which trouble is commonly called interstitial keratitis, are caused by syphilis acquired or inherited, and the difficulty will usually entirely disappear under specific treatment.

The various forms of opacities or circumscribed inflammations of the cornea, which go

on to ulceration and thus leave a scar as a visual obscurity, are all due to general diseases.

It is frequently found that cases of granular eyelids and recurrent corneal troubles which have resisted all forms of medical treatment are improved and caused to disappear by the correction of some co-existing error of refraction. The duty of the optician in this class of cases is to carefully search for complicating errors of refraction, and to correct them when found. In cases where an error of refraction is found it is legitimate and very frequently beneficial to order smoked glasses; especially when there is a *noticeable* degree of irritation. All cases of visual obscurity consult opticians regarding the possibility of having their defective vision relieved by glasses. Having carefully investigated the conditions of the refraction, accommodation and muscles, it is better to recommend all such persons to consult the nearest and best specialist; providing they have not already had advice from a competent person as to how the best interests regarding their poor vision can be served.

In old cases of corneal obscurity resulting from scar-tissue, there is no possibility of removing this defect. The vision can only be improved where such opacities are so localized, that by means of an artificial pupil the visual line may become directed through the corneal tissue which is clear of the defect.

Perforations in the central part of the cornea allow the aqueous humor to escape, and thus permit the lens to be forced forward in contact with the perforation. Under these circumstances the lens becomes firmly adherent to the perforation. As the aqueous humor again accumulates the lens is forced from its attachment back to its former position. The blemish on its surface is called anterior polar cataract.

We next take up the consideration of opacities occurring on and in the crystalline lens; all of which come under the general term of cataract. Cataract is a defect which always comes under the observation of the optician during its incipient stage. The patient experiences unusual reduction in his accommodation and a defect in his vision, which is not relieved to his satisfaction by the glasses he has been using. He therefore presents himself for additional assistance. The slight addition to the strength of his glasses, with a possible correction of any co-existing astigmatism, will greatly improve his sight. The improvement, however, will not be satisfactory because the vision will not be so good as it was before incipient cataract was developed. Such persons become immediately reconciled, and are contented with the vision obtained when it is explained that the unsatisfactory sight is due to cataract.

Another class of patients are encountered by the optician, who have already entirely lost all practical vision in one eye. They desire lenses for the other eye and are very solicitous regarding their future prospects, since they know from experience with the first

eye that a similar condition is now developing in the other eye. These persons are very grateful for any encouraging information regarding their sight. When such an individual with his poorer eye can detect the light of a candle at twenty feet in a darkened room, and can also locate the position of the candle at a distance of five feet when held above, below or to the right and the left of the eye, the cataract is simple, and he may be given the comforting assurance that he will be able at some future date to recover the sight of his poorer eye. When with his back to the light of the window he can no longer count fingers at a greater distance than two feet, the cataract is sufficiently ripe for removal. The shorter the distance at which he can count the fingers the riper the cataract.

A third class of persons who consult the optician are those who have had a cataract removed. They come for the proper convex lenses to compensate for the crystalline lens which has been removed. The average person will require about a convex lens No. 3½ for distant vision and No. 2½ for near vision.

These lenses frequently fail to bring out practical visual results. Under these circumstances an examination of the pupil by means of oblique illumination will demonstrate the existence of an opaque capsule through which a clear and proper opening does not exist.

SCRANTON, Pa., February 7, 1891.

DEAR DOCTOR: A young lady, 27 years of age, squinted with the left eye until two years ago, when the internal muscle was cut.

Two years have elapsed since the operation and subsequent treatment. She comes to me wearing +16 glasses, which, although better than nothing, fail to give her sufficient relief. She suffers especially in near work. I find a high degree of hyperopia present; +10+48 cat 100° she finds very clear, pleasant and satisfactory. The doctor, however, told her not to wear a stronger glass than +16, saying her eyes would not stand a stronger glass.

Is it possible the excessive belladonna dosing to which she was subjected could interfere with my giving her the proper glasses, or is the oculist mistaken? Why has he not corrected the astigmatism present? How could the correction of manifest hyperopia put any kind of strain on the eye?

The girl has lost vision in the eye that squinted.

I should not hesitate an instant in giving her the strongest convex glass through which she can see clearly and comfortably at twenty feet, besides correcting the astigmatism present. Nor can I see how the belladonna treatment (finished two years ago) could interfere with my counting an error of refraction at the present time.

R. B. OBERTEUFER.

You are entirely right in each of your conclusions. You have, however, probably corrected all of her hyperopia, as it frequently becomes entirely latent at her age. It was evidently latent two years ago.

New German Silver.

An excellent German silver is prepared by melting in a crucible 55 parts copper, 23 nickel, 17 zinc, 3 iron and 2 tin. This composition is in every respect equal to silver in appearance, fully as hard and not so brittle.

A. WITTNAUER,

Successor to J. EUGENE ROBERT & CO.,

No. 30 MAIDEN LANE, NEW YORK,

MANUFACTURER AND IMPORTER OF

WATCHES AND WATCH MOVEMENTS.

AGASSIZ
AND
LONGINES
MOVEMENTS,

FITTING

6, 16, 18 Size Cases, in 3 Grades.

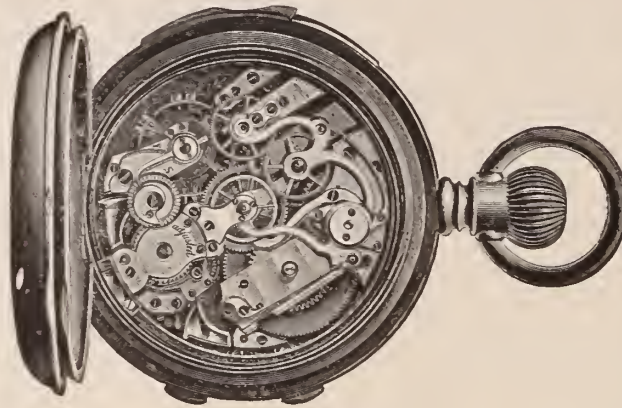

SOLE AGENTS FOR

LOUIS AUDEMARS

AND

JULES MONARD,

GENEVA

Unexcelled Timekeepers.

CHRONOGRAPHS, SPLIT SECONDS, MINUTE REPEATERS, &c.

16 and 18 Size Movements, Open Face and Hunting.

Thoroughly Adjusted for Accurate Time and Railroad Use.

The "BRYANT" Initial Ring.

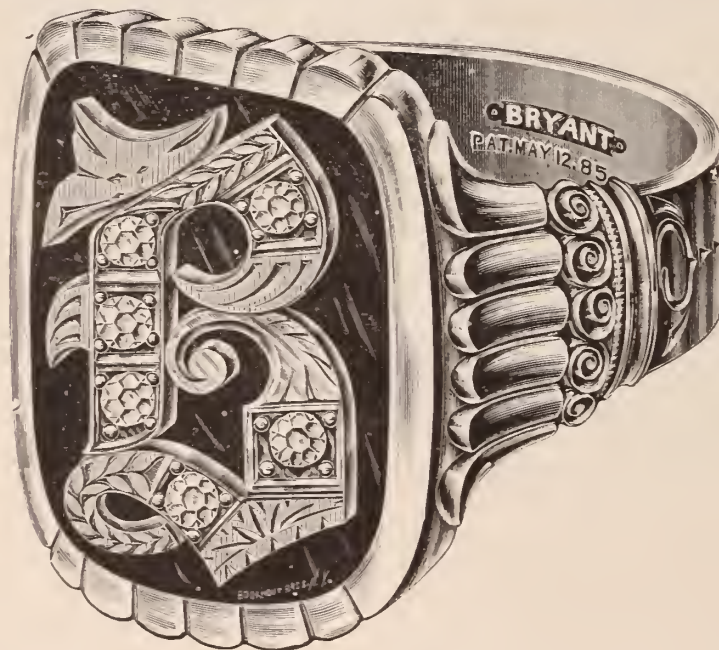

In Various Styles, Most Easily Interchangeable,
Handsomest and Best.

M. B. BRYANT & CO.,

10 MAIDEN LANE, - - - NEW YORK.

LEWIS BROTHERS,
Easter Novelties in Silver,
41 Maiden Lane, N. Y.

A. RICKERT. C.A. STIEHLE.
RICKERT & STIEHLE,
MANUFACTURERS OF
GOLD CHAINS,
SWIVELS AND SPRING RINGS.
Chain Repairing a Specialty.
13 & 15 Franklin Street, NEWARK, N. J.

WOOD & HUGHES,
Sterling Silverware Manufacturers.
New York Agents for the Derby Silver Co.'s
FINE QUADRUPLED PLATED WARE.
No. 16 JOHN STREET, - NEW YORK.
206 Kearney St., San Francisco, Cal.
HASKELL & MUEGGE, Agents.

BOOKS FOR JEWELERS.

W. B. DIEKIE,
67 William Street, New York,
PUBLISHER OF
Improved Watch Stock Book

—AND—
Improved Watch Repair Book.

SEND FOR DESCRIPTIVE CIRCULAR.

Theoretical and Practical Study of Depthing with Pinions of Low Number.

By J. Rambal, Watchmaker, etc., and Principal of the Horological School at Geneva, Switzerland.

(Continued from page 11, Feb. 18.)

It will be noticed that the point of crossing of the two curves e and e' , is situated a little below the point g ; consequently it does not touch the pinion leaf h . This result of this condition is that when the tooth of the wheel which follows the one represented in the drawing, comes in contact with the pinion h on the line of centres, *i.e.*, in the position of the line h' (fig. 5), the preceding tooth will already have left the leaf h . Thus it will be made clear that the contact of the wheel tooth with the line h' will happen before it has reached the lines of centre, even in the impracticable case, where the pinion leaf was to be reduced to a simple straight line.

7. As a rule we give to the leaves of a pinion of low number a thickness equal to one-third of the pitch of the gearing. Such leaves have sufficient strength. It is advisable not to exceed this thickness, as thereby we increase the tendency of the wheel teeth to come in contact with the pinion leaves before the lines of centre.

To locate the leaves of the pinion so formed, it becomes necessary to transfer the curve e' (fig. 5) to the position which it occupies in fig. 6, setting it at a sufficient distance from the pinion leaf to allow the necessary freedom. This operation has the effect of considerably shortening the curve of the

tooth, and it will follow that the tooth of the wheel will have left the flank h , before the flank h' will have reached the line of centre.

8. A noted watchmaker, Lepine, endeavored at an early period to improve such gearing as we have under consideration, by giving the entire curving to one side of the tooth only, thereby making it impossible for the tooth of the wheel to drive the pinion in both directions. The pinion was also constructed in such a manner as to meet the change made in the teeth of the wheel. An illustration of Lepine's gearing may be found in *The Swiss Horological Journal* of April, 1879.

9. We will now mention the necessary conditions under which the Ingold cutters should be used. These cutters are constructed on the same principles as those followed in the construction of gearing. We may compare the cutter itself to a pinion.

In order to produce the proper curve of a wheel tooth, or retouch the teeth of a given wheel, the diameter of a cutter must be made to harmonize with the primitive diameter of the wheel in the same proportion as the number of its teeth. In addition, the flank of the slot of the cutter must be a hypocycloid described by the same generating which would be correct for the leaves of the pinion gearing into the same wheel. These conditions are indispensable. The width of the spaces of the cutter must also correspond with that of the wheel teeth.

We will not say any more in regard to the Ingold cutters, as these have been fully described in the *Swiss Horological Journal* of September, 1877, by M. F. Bachschmidt.

PART II.

PRACTICAL CONSIDERATION.

10. Before proceeding, let us recapitulate the principles of the construction of gearing resulting from the preceding discussion. Therein we have stated the following points:

a. The primitive circles of the two mobiles must be to each other in proportion to the number of their teeth and pinion leaves.

b. The curves of the teeth, and the flanks of the leaves, are lines produced simultaneously by the same point in a generating circle.

c. In order that the flank of the pinion leaf be a straight line, radial with the centre of the pinion, it is necessary that the generating circle be half the diameter of the primitive circle of the pinion.

d. The thickness given to the pinion leaf should be one-third of the pitch.

e. The width of the wheel tooth must be such that a sufficient amount of play may be had between wheel and pinion.

11. It is evidently necessary that the epicycloidal curve of the wheel tooth be given the greatest possible length, in order to reduce to a minimum the action before the line of centre; or, what amounts to the same thing, the tooth must be left as thick as possible. Watchmakers understood the full importance of this more than a century ago. Preudhomme expressed himself as follows:

"The teeth of wheels acting on pinions of high number, such as 12 leaves, should have spaces equaling the width of the teeth. And as the pinions and wheels diminish in the numbers of their leaves and teeth, it is neces-

SIMPSON, HALL, MILLER & CO.

WALLINGFORD, CONN.

MANUFACTURERS
X X OF X X

FINE SILVER PLATED WARE,

Attention is called to their
New Line of



RÉPOUSSÉ

Superior to anything heretofore
manufactured.

CHICAGO STORE

141 & 143 STATE STREET,

M. N. BURCHARD,

MANAGER.



MANUFACTURERS OF THE
WM ROGERS,

WALLINGFORD, CT.

KNIVES, FORKS, SPOONS, &c.

CATALOGUES FURNISHED TO THE TRADE ONLY.

sary to augment in proportion the width of the teeth, in order that they shall present sufficient surface to allow the necessary length of curve to be given."

Jurgensen says also: "The teeth of wheels gearing with pinions of low number should be wider than those gearing with pinions of higher number."

It is true that many modern authors advocate the principle of equality between the width of the teeth and the spaces, though we cannot justify the sacrifice of so useful a portion of tooth, except on account of the facility which such equality offers for the trigonometric calculation for the height of the curve. Happily, in practice such a principle is seldom followed, but the tooth is generally made wider than the space. At least, such is our experience, the result of a large number of gaugings taken from all kinds of watches.

We will formulate a little further on the proportions which appear to us most suitable.

12. Let us now consider the complicated question of gearing with pinions of low number, *i. e.*, their action before the lines of centres. When this does not commence at an excessive angular distance from these lines, it does not constitute a grave defect. Unfortunately the wheels are not always perfectly divided, nor are the pinions correctly formed. Consequently, on account of such defects, an augmentation of the evil of the action of the wheel and pinion taking place before the lines of centre, will sometimes occur. This

may degenerate into a positive abutting, and thus become a cause of stoppage.

Such glaring defects were met with quite often in the past, when the teeth of wheels were shaped by the hand; and from this cause they presented great irregularity. An author, "Camus," who lived in the last century, proposed a remedy for such difficulties. We quote from the *Modern Horological Lectures* of M. C. Saunier: "As we can never hope to form the teeth of wheels with such accuracy that the pitch circles of the wheels and pinion shall always revolve with equal velocity, and as the irregularities and other faults in the teeth will make the lead measured from the lines of centres in some cases not sufficiently long, thus occasioning buttings, etc., makers will do well to avoid these inconveniences by making the mobile which drives larger than it should be in comparison with the mobile which is driven.

"By this increase in the diameter of the wheel, which should be proportioned to the faults which are to be provided against in the form of the teeth of the wheel, the tooth immediately succeeding the one which is leading a leaf beyond the line of centres will engage with the next leaf somewhat later and when the former tooth has driven the pinion as far as it can uniformly, the wheel has a somewhat greater velocity than the pinion, and this is a fault. But this intentional fault is less objectionable than the buttings which would probably occur if it did not exist."

(To be continued.)

The Mayor's Clock.

THE care of the fine clock in the office of Mayor Charles Sidney Smith, of Boston has recently been given to Hermann A. Ockel, the Weybosset street watchmaker. For some time it has not kept the seconds as accurately as it was thought it should and Mr. Ockel has undertaken the task of making it keep up with the times.

The clock is a costly one, and besides letting the people in the office know what time it is and regulating the strikers in the corridors, it regulates the fire alarm strikers throughout the city by means of electric wires. These strikers announce the time at 12 noon and 8.30 o'clock in the evening, and the people get the time for their clocks in that way. Mr. Ockel regulates the clock twice a week, getting his time from the Observatory at Washington. The clock in his store from which Mr. Ockel takes his time cost \$1,200 and he says it has varied scarcely a second for a year. He thinks the Howard clock in Mayor Smith's office can be regulated so that it will run with the same accuracy.

Mr. Ockel has had an extended experience in the care of clocks, being the custodian of three private collections of antique time-keepers which are among the largest in the country, if not in the world. He also has charge of the clocks in the Narragansett hotel, the Hope Club house and the Union railroad station, as well as those in Grace church and in the First Congregational church.

ESTABLISHED 1841.

CARTER, SLOAN & CO.,

MANUFACTURERS OF

FINE JEWELRY,

15 MAIDEN LANE, NEW YORK.

A. CARTER, JR.
A. K. SLOAN.
C. E. HASTINGS.
GEO. R. HOWE,
WM. T. CARTER.



Factory, NEWARK, N. J.

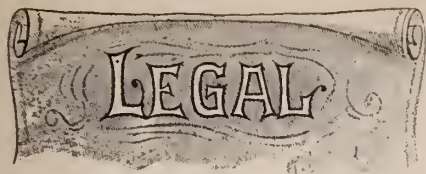

CONSTRUCTION OF ACCIDENT INSURANCE.

A merchant who is insured under an accident insurance policy which provides that any member who is injured while engaged temporarily or otherwise in an occupation more hazardous than that in which he is insured he shall be paid as for the occupation in which he is injured and not as for that in which he was insured, may recover upon accidental injury while hunting as a matter of recreation, the amount specified for a merchant, but not the amount specified for a hunter. He cannot be said to be engaged at all in the "occupation" of hunting, while hunting merely for sport. Where a mutual association wrongfully refuses to make an assignment, if it is shown that had an assignment been made at the proper time the full amount of the policy would have been realized, it is proper to enter judgment for the full amount of the policy.

COMMUNICATION OF FACTS REGARDING EMPLOYEE.

Where a person is about to enter the employ of another, he has no right of action against the former employer who, in good faith without malice, voluntarily and in the honest belief that he is discharging a duty he owes to a neighbor, and with a full conviction that the statement is true, communicates to the person about to employ him the information that when in his employ he had stolen from him. Made in this way and under these circumstances this is a privileged communication.

PROTEST OF NOTE.

Where the law requires that on the protesting of a note the notary shall give notice thereof in writing, a notice is sufficient which contains in substance a true description of the note together with a statement that it has been presented at maturity and dishonored, and that the holder looks to the indorser for payment. It is not necessary that the notice itself be addressed if the envelope containing it be properly addressed. Where the law requires that the notice shall be served by delivering a copy to the person entitled thereto or by depositing it in the post office directed to him, service by mail is good upon a resident as well as a non-resident indorser.

PAYMENT OF NOTE BY BANK.

Where a note which is made payable at a bank is paid at its maturity by the bank, the bank then becomes the equitable owner or purchaser of the note and is entitled to set it off in a suit by the maker of the note to recover a balance due him on an account as a depositor.

Copyright, 1890, Law News-Bureau.

THE BOWDEN Seamless Plain Ring,

IS MADE ONLY BY

J. B. BOWDEN & CO.,

Makers of FINGER RINGS of every Description,

COR. BROADWAY & JOHN STREET,
NEW YORK.

WE DESIRE to call your attention to our large and varied assortment of

Complicated, High Grade Gentlemen's and Ladies'



In Gold Cases, both Plain and Enameled, in Choice Designs.

THE LARGEST STOCK EVER SHOWN IN THIS COUNTRY.

NON-MAGNETIC WATCH CO.

OF AMERICA

CHAS. McCULLOH, RECEIVER,

177 Broadway. - - NEW YORK.

SEXTON BROS. & WASHBURN,

41 MAIDEN LANE, NEW YORK,

MANUFACTURERS OF

FINE JEWELRY,

INCLUDING A FULL LINE OF MOUNTINGS.



PROMPT AND CAREFUL ATTENTION GIVEN TO SPECIAL ORDER WORK.

Town Talk.

Among the conveniences and improvements that are offered to manufacturing jewelers in a fine factory building now being erected on Union Square, is a double flooring with roof paper between the two sections. The advantages of such an arrangement are apparent. Gold dust and filings will lodge in the crevices in the floor and sink gradually out of reach. With only a single flooring the matter will be lost in the plaster and among the beams; with the double flooring the dust is collected on the paper. A section of the double flooring of Robbins & Appleton's large watch case factory on Bond street, was recently removed and from the dirt and refuse \$2200 worth of gold has been extracted.

Considerable discussion is going on regarding a revision of the existing patent laws which are so much open to abuse. Many favor a modification of the law that will prevent a patented article being withheld from sale, thus frustrating the purposes of the inventor and the essence of the letters-patent. An invention or improvement is a public good. The man who invents a process by which the cost of making the head of a pin is reduced one ten-thousandth part of a cent, looks upon himself as a producer, and considers himself a benefactor to mankind. Now, if this invention interferes with the prosperity of a private concern who, fearing the competition, buys up the letters-patent and shelves them, is the purpose of our patent system realized? No, say the reformers. One cites the case of a patented process for the hardening of glass, and its application to lamp chimneys in common use, especially among the poor, which was bought up and pigeon-holed by a concern so that they might continue to make a thin and worthless article. But it is well for these reformers to remember that nine-tenths of the manufacturing industries of America are based upon our patent system, and that no tinkering

with it should be undertaken without careful forethought and preparation.

Perhaps it is not widely known that E. Aug. Neresheimer, besides being one of our principal diamond importers, is treasurer of the New York Bacteriological Institute. This organization, through Mr. Neresheimer, last week sent out an appeal to the public, asking for their support in an undertaking, the object of which is the establishment in New York city of an institute to be specially devoted to the study and treatment of tuberculosis, hydrophobia, diphtheria, and other contagious diseases. Dr. Paul Gibier, the pupil of Prof. Pasteur and Dr. Koch, is the presiding officer of the Institute.

The *piece de resistance* in the collection of antiques at the establishment of J. H. Johnston & Co., is a Medici inkstand, which is over three hundred years old. Mr. Johnston has refused \$5,000 for it. This ink well bears the coat of arms of the Medici family, from which the legend of the three golden balls before all pawnbrokers' stores is derived. In the early part of the sixteenth century, the founder of the Medicis settled in Florence and soon won fame as a physician. He became very rich and loaned money at usurious rates. Later he was baroneted and adopted six golden pills as a coat of arms. For generations the Medici family were famous as money lenders; and have since retained the respect of their disciples.

In numerous of the "fireside" publications that emanate from somewhere in this city, appear advertisements which offer bonanzas like the following: "Genuine gold-plated watch made of two heavy plates of 18-karat solid gold over composition metal; the movement is a fine Elgin style, richly jeweled, quick train, expansion balance, patent pinion, patent escapement, etc. Price \$5.98." The advertisers are usually corporations (at least they sign themselves so, "Co." ending almost every name), and plainly conduct business on the public's gullibility.

Samuel Eichberg was speaking, the other day, about his recent trip to Europe. "I was gone six months," said he, "but it would have taken me more than six years to see all the beautiful things. In Italy alone six months could be easily spent viewing the art treasures. But the traveler should be a young man, so that the remembrance of his tour might furnish food for pleasure for many years." Mr. Eichberg is now quite on in years and is very much of a philosopher. For fully a half hour he kept the writer interested, expounding his views on the advantages and disadvantages of accumulating wealth.

A little store uptown has a card in the window bearing this legend:

MARK THIS.
GERMANY'S BIZ MARK
was a great man.

OUR BIZ MARK
IS
GREAT BARGAINS.

Many jewelers have now in connection with their establishments an art stationery department. These goods lend themselves very readily to effective window decoration, either by themselves or as an adjunct to the general display. The following is a description of the very attractive window of a well-known art stationery house on Union Square: Within the show-window is a large oak desk covered with maroon-colored plush; spreading out from the centre of the desk in the form of a circular fan are various social cards; arranged at the sides and upper part of the desk are bright polished inkstands, pens, and other writing utensils.

Jay Gould in a recent interview granted to "Gath" made the following simile: The railroad business of the United States is to all other things as a mainspring in a watch is to the works. The various manufactures, mines, business centres and so on, are nothing more than small cogwheels, dependent upon the regular action of the railroad mainspring."

* * * THE * * *

 Courvoisier Wilcox Mfg. Company's
 

NEW

10-K. GOLD WATCH CASE,

In O and 6 Sizes.

Unsurpassed in beauty; style and finish, costing no more than the better grades of filled cases; will wear for longer than a lifetime, and will always be a *Solid Gold Case*.





PARIS, Feb. 16, 1891.

NEARLY all Parisian jewelers are now endeavoring to have displays more and more varied, so they often admit to their show windows not only articles which are not exactly in their line, but substances that are very seldom seen side by side with precious stones; except perhaps in old bibelots shops. Any substance, valuable or not, which gives a pretty effect through being either skilfully worked or tastefully associated with others, is welcomed by them. For instance, we see a large quantity of articles for adornment, or for pocket use, introducing glass in connection with gold and gems.

We notice in another display a singular variety of pieces most dissimilarly decorated. A gold dragon-fly with wings of changing colored glass, faintly wrinkled; a bracelet in fine blue enamelled gold imitating watered silk, with a wide clasp in open worked platina; a wicker-basket jewel case in oxydized silver showing, on ruffled gray satin, a small bunch of dried raisins as real as can be; a hexagonal scent-bottle, in thick glass, of a smoky yellow color, exhibiting on each face a spray of flowers made of brilliants incrusting in the glass, with a

large opal on the frosted gold stopper; a tiny rabbit in massive chased gold (a clumsy looking paper weight); a very small traveling clock, square in shape, in open worked steel, with narrow bands of enamelled ornaments framing each face, the hour-marks and the hands showing in chased yellow gold; a large paper-knife in ivory, incrusting with gold and turquoises, forming a spray of forget-me-nots on the handle, the blade being prettily decorated with arabesques in *respercé* work; besides a great variety of jewelry sets, introducing diamonds and pearls, rubies, emeralds, sapphires, etc., and here and there a bon-bon box made of jasper, or malachite, or lapis-lazuli, with chased gold mounting enriched with brilliants.

An important wedding took place on the 3d of February at the Church St. Philippe du Roule, the bride being Mlle. Marguerite Luzarche d'Azay, and the bridegroom Mr. Pierre Lebaudy, son of the well-known sugar refiner. Among the presents given on that occasion, I noticed a magnificent diadem made of diamonds and pearls, and five bracelets consisting of a thin gold circle with only a large diamond or sapphire.

The table-set, in polished silver, presented by Mr. Jules Lebaudy, is of a very sober Louis XVI. style. The handles of the spoons and forks, and the rims of the dishes and tureens, exhibit chiefly a series of crossed ribbons.

When chased or stamped monograms happen to be objected to on account of being un-

pleasant to feel while handling a spoon or a fork, I think they ought only to be replaced, on pieces with a relief decoration, by engraved ones bordered by a deep sloping cut, calculated to set them off and to raise them, in appearance, to the level of the ornaments.

This *trompe-l'œil* work is especially required on polished silver. An elegant toilet set in the same style which was given by Mr. Roussel, has a better effect. The monogram is well shaded. Among the other presents several pretty scent bottles, some very elegant fans and a great many useless knick-knacks of value deserve mention.

Another wedding worthy of notice, which took place on the 4th of February, is that of Mlle. J. de Rougé with the Viscount Pierre Paultre de Lamothe. The presents in jewelry chiefly consisted of diamonds and sapphires. A diamond bouquet for the corsage, with a light bow-knot of the same stones holding it together was very much admired.

A well-known collector is afflicted with a weakness, which prompts him to be extremely liberal with ladies of taste, who come to have a look at his treasures. This has caused him to part with many of his most precious relics. In order to prevent his generous bent from proving utterly ruinous to his collection, he has determined upon having two glass cases, one filled with real old bibelots, and another one with pseudo-ancient works. Ladies will now be requested to admire the contents of the second glass case exclusively.

JASEUR.

IMPORTANT NOTICE.

The New Trenton Movement.
H. T. G. and O. F. S. W.



(OPEN PLATE.)

No. 40, Nickel, - - - \$4.00
No. 41, Gilt, - - - 4.00



(CLOSED PLATE.)

No. 60, Nickel, - - - \$3.75
No. 61, Gilt, - - - 3.75

LESS CASH DISCOUNT.

We beg to notify the trade that we have placed on the market a NEW MODEL

18-Size, Seven Jeweled, S. W. Nickel Movement,

SURPASSING ANYTHING YET MADE FOR THE PRICE, and to which we invite your attention. These movements possess several new features which offer special advantages to watchmakers. They are Quick Train, Straight Line Lever Escapement, and have Safety Centre Pinions and hard enamel Dials. The barrel can be removed without disturbing the train or stem-winding parts. They are beautifully damaskeened, well finished and attractive in appearance and are EXCELLENT TIMEKEEPERS. EVERY MOVEMENT FULLY WARRANTED.

The Best Low Priced Movement in the Market.

FOR SALE BY THE JOBBING TRADE.

Send to your jobber for a sample movement. If he does not keep them, write us and we will furnish you the names of jobbers who do.

TRENTON WATCH CO., Trenton, N. J.

OPPENHEIMER BROS. & VEITH, Diamonds, Watches and Jewelry,

2 Tulp Straat,
AMSTERDAM.

35 Maiden Lane,
NEW YORK.

We beg to inform the trade that we are still in a position to fill orders for

✂ DUEBER HAMPDEN WATCHES ✂

Of all grades, from stock purchased previous to the closing of the factories at Canton.

OTTO GAS ENGINE WORKS

SCHLEICHER, SCHUMM & CO.

PHILADELPHIA.

CHICAGO.

20,000 SOLD.

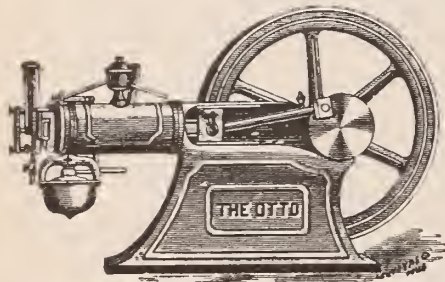

Guaranteed to consume 25 to 75 per cent. less Gas than ANY other Gas Engine doing the same work.

Our 1-horse power engine is largely used by Jewelers.

Price recently reduced to \$325 at Factory in Philadelphia.

Send for Circular and Reference List relating to this size.



CHICAGO WATCH TOOL CO.,

52 MADISON STREET, CHICAGO, ILL.,

MANUFACTURERS OF

Staking · Tools, · Foot · Wheels, · Polishing · Lathes

AND ALL KINDS OF

WATCHMAKERS' AND JEWELERS' TOOLS.

Catalogues sent upon application.

OSTBY & BARTON,

SOLID GOLD BAND, STONE

- - AND FANCY RINGS - -



* — ALSO A LARGE LINE OF EMBLEM RINGS. — *

AIKIN, LAMBERT & Co.,

23 Maiden Lane,
NEW YORK,

Manufacturers and Exporters of

Fine Gold Pens, Pencils,

TOOTHPICKS, HOLDERS,
And Novelties in Silver, Pearl, &c.



THE BEST FOUNTAIN PENS.

New Assortments in SHOW CASES and FANCY TRAYS for JEWELERS.
Price Lists and Catalogues for intending Purchasers.



Also American and Swiss Watches.

DIAMONDS, Loose and Mounted.

Gold and Silver Thimbles,

CHAINS and JEWELRY in New and Staple Patterns.



RYDER & DEARTH, DESIGNERS & ENGRAVERS

Fine Commercial and Copper-Plate Printers.

A Specialty of

Jewelers' Printing, Cuts and Electrotypes.

Headquarters for JEWELERS' CARDS.

BEST WORK,

PROMPT DELIVERY.

LOW PRICES.

No Order Too Large! None Too Small!

146 Westminster Street,

PROVIDENCE,

RHODE ISLAND.

To Gild by Contact.

“IN my long practice,” says E. Gerwitz, in the *Deutsche Uhrmacher Zeitung*, answering a complaint about the inferior qualities of the commercial gold solutions, “I have generally found them efficient for all ordinary purposes—if used in the right way. The many failures experienced by others in their first attempts at gilding are most frequently due to the circumstance that they do not employ the solution properly.”

Before an article is to be placed in the gold-bath it is absolutely necessary that it be cleaned in the most perfect manner possible. For copper, the principal metal which comes into the gilder's hand, and its alloys, the scouring operation is the most difficult and requires the following chemical operations before the article to be gilt is fit for the operation: (1) Scouring with potash, lime or caustic potash; (2) pickling in sulphuric acid; (3) passing through cold nitric acid; (4) passing through nitric acid and lampblack; (5) passing through an acid mixture, and (6) passing through nitrate of mercury.

The inexperienced operator will now understand why he has frequently obtained black spotted gilding, and that the poor result was not the fault of the gold solution. A number of times have gildings, quite satisfactory in other respects, been sent to the writer for his opinion; and in nearly every instance the sender has asked why the gilding turned out so brown. The only reason that could be assigned was that the operator had not treated the gilding properly.

The tyro who makes his first attempts at gilding or silvering should begin with a small, smooth article, and gradually increase the difficulty of his experiments, so as not to experience too much loss and disappointment; a heavy dose of which he will have to swallow even then.

Every dip or contact gilding that is performed without the assistance of a battery, is, strictly speaking, only a coloring of the article. A coating that will adhere well is produced by first gilding the article, then dipping it into a solution of nitrate of mercury, and then returning it to the gold bath. This operation should be repeated several times until the gilding has obtained the required thickness and adhesiveness. The thin film of nitrate of mercury forming each time is dissolved again in the gold bath to make room for another layer of gold, which has a great affinity for quicksilver, and separates from the gold bath to combine with it.

The writer has used this method for the past two years and has gilded articles in this manner for which he before had to employ a battery. The method is also preferable to that requiring a battery, because the gilding obtained by dipping is distinguished from the latter kind by the softer tone, greater lustre and purity, that only pure gold will deposit; while by gilding with the battery a basic salt of gold will invariably separate.

The thickness of the gold film deposited can easily be tested by trying it from time to time with nitric acid.

USE THE 
AMERICAN MAINSPRINGS
 FOR ALL KINDS OF AMERICAN WATCHES.
 [FACSIMILE OF WRAPPER.]

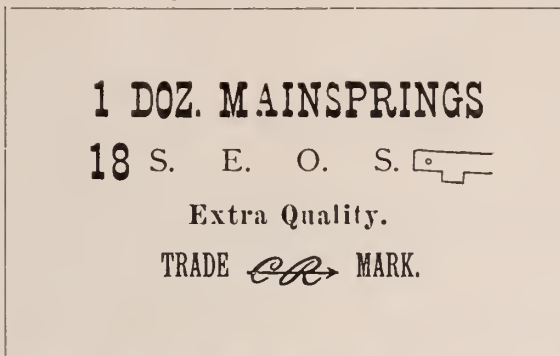

THE BEST IN THE MARKET.

L. H. KELLER & CO.,

Dealers in Fine Watch Materials and Tools.

Agents for the Patek, Philippe & Co. Watches.

64 NASSAU STREET, NEW YORK.

TELL A. BEGUELIN,

IMPORTER OF

WATCHES.

Watch Materials, Tools and Glasses,

NO. 71 NASSAU STREET,

(UP STAIRS.)

NEW YORK.

Sole Importer of Material for the

“Bijou,” “Victor,” “Boston,” “Bristol,” “Adelphia,” “Jockey Club,” “Wallingford,” “Cæsar,” “Lady Racine” and “New Haven” Watches.

AMERICAN WATCHES.

ALSO STEM WIND WHEELS.

IMPORTER OF

Full Line of **SWISS WATCHES,**

ALSO IMPORTER OF

FRENCH CLOCK GLASSES.

TO THE TRADE.

FINE WATCH REPAIRING

BY

JOHN C. SIMMONDS,

18 JOHN STREET, NEW YORK.

New pieces, such as Chronometer Locking Springs, Balance Staffs, &c., made in the best styles. Watches sprung and adjusted to temperature and positions.

ATTENTION!

ALEX. WIEDERHOLD,

20 MAIDEN LANE, N. Y.,

Repairing Jeweler.

Jobbing sent to me by mail or express will be repaired and returned promptly. Prices Moderate and First-class Workmanship Guaranteed.

ARTIFICIAL EYES!



STOCK ORDERS of Selection Packages.

Largest Assortment.

GENEVA OPTICAL CO.,

23 Washington St., Chicago.

WATCHES.

JOHN B. YATES,

147 NASSAU STREET,

NEW YORK.

SPECIALTY:

UNITED STATES WATCHES

WIGGERS & FROELICK,

60 NASSAU ST., NEW YORK,

Sample Cases and Trays

For Watches, Jewelry, Optical Goods, Etc.

WE STRIVE TO MAKE THE BEST

The Highest Grade

— OF —

Electro Silver

Plated Ware

Is Stamped with the



ROGERS TRADE-MARKS.

MANUFACTURED BY

The Wm. Rogers Manufacturing Co.,

P. O. DRAWER 30,

HARTFORD, - CONN.

FASHIONS, IN JEWELRY

A Lady's Ramble Among the Jewelers.

One of the prettiest jewel-boxes out is of tortoise shell with pierced silver mountings and padlock.

Articles specially prized this winter as favors, are the new ticket cases mentioned above, acorn and heart-shaped needle cases and emeries, and tiny heart-shaped scent sachets of gold or silver.

Long pliant sprays of silver enamelled to simulate ivy leaves, wild roses and thin foliage, and holly leaves and berries, are worn sometimes on the bodice and often on the skirt draperies of evening gowns.

Luxurious appointments for my lady's work-box are heart-shaped emeries with repoussé silver mountings, and acorn-shaped needle cases of silver. Or, the emery may take on the old strawberry pattern with calyx of gold.

With other out-of-the-way places for wearing the watch, the idea has been suggested of dropping it inside the high dress collars and letting the short chain and pendant hang as loose ornaments in place of the brooch.

A convenience for the smoking-room is the self-adjusting lamp in silver. It comes in various forms, in all of which the arrangement is such that the light remains always at the top, in whatever position the lamp may be held.

Numbered with the many small elegancies in silverware designed for the five o'clock tea table, is the water-lily stand. It consists of a silver plate modelled like the leaf of a water-lily, and a cream jug and sugar basin shaped like the flower itself.

A convenient novelty which appeals to both sexes is a silver case for elevated railroad, bridge, ferry and car tickets. This case can be carried in the vest pocket or worn as a pendant from the watch chain. It is quickly operated by a thumb-piece slide which throws the ticket into the hand. The beauty of this ornament is that it can be worked without removing the glove or even taking the case from the pocket.

ELSIE BEE.

Teutonic and Majestic Models.

ON Monday there was placed in the store of Tiffany & Co., near the entrance, the perfect and magnificent model of the two new White Star steamers, H. M. armed cruisers *Teutonic* and *Majestic*, which was exhibited at the Paris Universal Exposition of 1889. This model is the handsomest ever made, the expense incurred in its construction reaching \$15,000. It is twelve feet long, and is a precise duplicate of the floating pal-

aces on a small scale. All the most recent improvements in steamship building are accurately depicted. The model is displayed in a heavy plate glass case on an elegantly carved rosewood stand fifteen feet long.

Tiffany & Co. are displaying this elegant piece of handiwork at the solicitation of Ismay, Imrie & Co., as they did the models of the *Umbria* and *Etruria* of the Cunard line, and the four Transatlantic steamers. They will exhibit it for this week only.

Emil Schorbach's Death.

EMIL SCHORBACH, southern traveler for Koch & Dreyfus, whose sad and tragic death at Paris, Texas, on February 9, so shocked the trade, was temporarily buried in that town. It was the intention of those who attended to the burial, Jonas Koch, of Koch & Dreyfus, who arrived in Paris on Feb. 11, J. A. Martin, of J. A. Martin & Co., local jewelers and friends of the deceased, and others to remove the body to New Orleans, for which city Mr. Schorbach had an inordinate love; but his many friends there telegraphed them to let matters rest for a time. There is a possibility of the body being transported to Germany, but the deceased's New York friends think that it will permanently rest in the city of his love, New Orleans.

Mr. Schorbach had been with Koch & Dreyfus since 1866, and his many trips in their interests had made him so well-known and loved by the southern trade, that regrets are heard from all sides. Strict in his integrity and genial in disposition, he retained their respect while he excited their friendliness.

His love for New Orleans dates back to 1864, when as quartermaster of the 7th Missouri Cavalry he was encamped in that city. He was honorably discharged in 1865 at St. Louis, and returning to the Crescent City in 1866 he engaged with Koch & Dreyfus.

A Disastrous Fire.

WESTMINSTER, B. C., Feb. 16.—A fire raged through this city yesterday and destroyed about \$500,000 worth of property. It started on the premises occupied by F. Stiersky, a watch-maker and jeweler, on Columbia street, and the whole block of buildings was ablaze before the fire department had succeeded in getting to work. For two hours the firemen fought the flames and were just getting them under control, when an explosion in the rear of one store occurred, smashing almost every pane of glass within a radius of half a mile, and bursting all of the hose pumping on the fire. The fire then spread quickly to the surrounding buildings.

Mr. Stiersky's store is completely obliterated.

CONNELLSVILLE, Pa., Feb. 2, 1891.

Enclosed please find P. O. note for two dollars, amount of subscription to THE CIRCULAR. As you know I have been taking it for some time, and I want it from its start as a weekly.

CHAS. H. WAYS.

CROSS & BEGUELIN,

21 MAIDEN LANE, N. Y.



The Old Reliable CENTENNIAL.

Best Nickel Watch Made.

OVER 325,000 IN USE.

Jobbers of all American Watches. † †

† † Gold and Rolled Plated Jewelry.

WATCH TOOLS, GLASSES, Etc.

SEND FOR PRICE LIST.

A. LUDWIG & CO.

SILVERSMITHS,

(TO THE TRADE ONLY.)

247 & 249

CENTRE STREET

TRINKMAN BUILDINGS,

NEW YORK.

A. LUDWIG, for the past 9 years Designer and Superintendent for George W. Shiebler.

SILVER NOVELTIES

A SPECIALTY.

Designs and Estimates Cheerfully Furnished.



Philadelphia.

James Doyle, whose *penchant* was "picking up" articles in jewelry stores, was sentenced to nine months' imprisonment in the Quarter Sessions on the 16th inst.

Louis P. White, the agent of the Dueber and Hampden Companies, has completed the improvements in his rooms at No. 631 Chestnut street. In his show-rooms he has a most elaborate display of French and American clocks and bronzes.

John Perry and James McLaughlin, two old offenders, who pleaded guilty last Thursday in the Court of Quarter Sessions to the larceny of seven rings, valued at \$54 from various jewelry stores, were sentenced by Judge Arnold to five years each in the Eastern Penitentiary.

In the Common Pleas Court, on the 18th inst., in the case of John J. Fahey vs. Adolph Newman, a verdict was rendered for the defendant. The suit was for alleged slander, and for forcible detention of the plaintiff, a 16-year old boy, who was employed by Mr. Newman in the jewelry business.

M. Sickles & Son, of No. 618 Chestnut street, have taken the agency for the Parker & Whipple alarm clocks. These clocks, which are made in Meriden, Conn., are small, but are very neat and useful. The success attending their being placed on the market is verified by the fact that within the last ten days the Philadelphia agents sold nearly one thousand.

The Supreme Court of Pennsylvania, sitting in Philadelphia, has affirmed the decision of the Common Pleas Court of Lebanon County, in the case of the Commonwealth against Richard Eichenberg. The plaintiff was fined under the act of 1869 for peddling jewelry without a license. Suit was brought before an Allentown alderman, who gave judgment against the plaintiff. The evidence showed that he merely solicited orders

throughout the county and delivered the goods. The Supreme Court, in its opinion, said that neither the Constitution nor the act of April, 1876, gives an appeal as a matter of right in cases of summary conviction, but only upon cause shown, and consequently the appeal was dismissed.

Corporation Syndicate of American Industries.

PROVIDENCE, Feb. 23.—A meeting of manufacturing jewelers of this city was called for Saturday evening at 8 o'clock for the purpose of taking some action relative to the formation of a syndicate to be known as the Corporation Syndicate of American Industries. A number of the manufacturers were present at the place of meeting, Narragansett Hotel, but nothing formal was done, although the scheme was vigorously discussed. Several of them signified their intention of going into the project if a sufficient amount of stock was subscribed for, but no signatures were received, there appearing to be no one present who was willing to take the initiative in the matter.

The prime movers in the scheme are Hyman Ascher, a commission merchant on Maiden Lane, New York, and J. J. Cohn, manufacturing jeweler of the same city. The idea is to open a general export trade with South and Central Americas for all classes of American industries. Mr. Ascher explained at the meeting that they desired to form the syndicate with a capital of 1,000 shares at \$250 each, 75 per cent. of which was to be taken in goods. Mr. Cohn stated that he had already got subscribers to the amount of \$22,000 in New York among other lines of business and that about \$8,000 had been taken in Providence by the jewelers, making a total of about \$30,000 out of the desired \$250,000.

The promoters of the enterprise claim that they do not expect to hold any future meetings, at least not at present, but that Mr.

Ascher will call upon the manufacturing jewelers personally during the next few weeks and endeavor to interest them individually.

The jewelers in this city appear somewhat loth to take hold of the scheme, preferring to see it develop to healthier proportions than at the present time. Although the scheme is a very plausible one, the promoters do not yet seem to have matured their plan sufficiently to give a clear and comprehensive idea of how they contemplate its fulfillment. Messrs. Ascher and Cohn are confident that the scheme will be a success, and do not feel discouraged at the apparent lack of interest in the meeting on Saturday evening.

Isidor Kottl's Lively Time.

Last Saturday a young man visited the store of Isidor Kottl, at 1598 Ave. A, and examined the jeweler's stock of watches. He left without purchasing anything, but said he would call again. At nine o'clock on Monday morning he paid his promised visit, and selected a gold watch valued at \$45.00.

He asked to see a chain, and as Mr. Kottl turned to get some chains, the young man darted toward the door with the watch. The jeweler noticed the movement and, jumping over the counter, barred the thief's exit. Then the young man drew a loaded revolver and presented it at Mr. Kottl's head. Meanwhile a pal stood in the doorway ready to offer assistance. The jeweler called for help as the unwelcome customers rushed down the street.

They were overtaken and arrested, and before Justice Diver, in the Harlem Police Court, were held for examination in \$1,000 bail each. The man with the revolver said he was Jas. Russell, nineteen years old, of 276 Bridge street, Brooklyn. His pal described himself as Chas. Morrell, eighteen years old, of Third avenue and 125th street. A number of pawn tickets representing jewelry supposed to have been stolen were also found in the prisoner's possession.

COMPARE

ALL OTHER GOLD FILLED CASES WITH THE CELEBRATED



CROWN, LION,
EXCELSIOR

HAND ENGRAVED CASES.

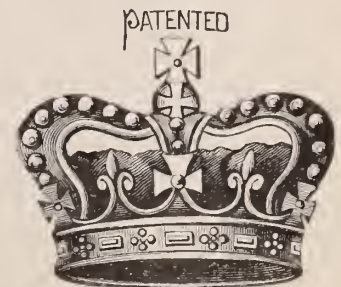

WARRANTED

MADE BY

H. MUHR'S SONS, 629-631 CHESTNUT ST., PHILA.

The Vermeister Auction Sale.

ON Friday last a public auction of the stock and fixtures of Vermeister Bros., 303 Manhattan avenue, Greenpoint, L. I., was begun, under the order of Assignee Henry Rosellen. The sale is for the benefit of the insolvent's creditors, though it is not likely that the assignment will be accepted by them. They claim that just before the assignment in December last, the Vermeister Bros. transferred property to their wives "for love and affection," and also to their father-in-law, a Mr. Rahder. The preference to Louis Vermeister, who owned George Vermeister's share in the business, which, together with a mortgage he held, amounted to \$8,000, they also claim to be unlawful, as the debt was announced but a few days before the failure.

On Wednesday last Judge Ingraham granted orders to vacate an order for the examination of the Vermeister Bros., Rosellen and Rahder, which had been granted H. Henrich through his attorney, G. C. Comstock, to obtain evidence to be used in a motion brought by the former parties to vacate an attachment which had been granted Mr. Henrich. This motion is on the calendar for the present week.

The Stern & Stern Failure.

THE actions of the Columbus Watch Company and other attaching creditors of Stern & Stern, whose claims amount to about \$60,000, against Stern & Stern, and the judgment creditors whose claims amount to about \$40,000, to set aside the judgments, were last week tried before Judge Beach in the Special Term of the Supreme Court, Part 2.

A number of witnesses were examined and at the conclusion of the trial Judge Beach reserved his decision. March 6, 1891, has been fixed by the Court as the date on which to submit the briefs of all parties.

The cases were tried by Franklin Bien, as counsel for the plaintiff, and Hays & Greenbaum and M. Warley Platzek for the defendants. A decision is expected during the latter part of March.

Dayton.

The craze for oxidized silver, which originated some months ago, is still quite the craze. Patrons still call for it, although ordinary bright silver finds a good market.

Among the traveling men who visited Dayton recently were: A. J. Perry, representing Meade & Co., of Chicago; M. Wolf, with Veit, Hirsh & Co., New York; S. B. Abbey, with E. Ira Richard & Co., New York; F. L. Carpenter, with Reed & Barton, Taunton, Mass.; Mr. Crane, of Stobell & Crane, Newark, N. J.; Henry Pattburg, Jr., with the New Jersey Lamp and Bronze Works, New Brunswick, N. J.; C. Wilfeng, with Simons Bros., Philadelphia, Pa.; and Albert F. Carter, of Carter, Sloan & Co., New York.

Lancaster, Pa.

Among the traveling men who were in the city the past week were H. Henrich, manufacturing jeweler, 35 Maiden Lane, New York; S. Valfer, of Valfer & Co., New York; B. E. Osgood, of F. S. Shepardson & Co., North Attleboro, Mass.; Harry Retzlau, of M. Adler & Co., New York; Theo. Evans, of Hodenpyl & Son, New York; Frank N. Sackett, of Sackett & Welsh, New York.

E. G. Hooner, will on the first of March open a jewelry store at 25 North Third street, Harrisburg, in the room lately occupied by Perkins & Oyne, jewelers. Mr. Hooner was assistant foreman of the repair department of the C. R. Smith & Sons' establishment, Philadelphia, for several years, and has the most flattering testimonials from his late employers. Mr. Hooner's former home was Harrisburg, and in engaging in business among his former friends he is apparently assured of success.

Mr. Levi W. Groff, of 807 North Queen street, this city, is the owner of the English bull-eye silver watch which belonged to Ben. Franklin, and which was reported sold at the Baker sale in Philadelphia this week for \$2,100. Mr. Groff, however, says that the watch was not sold; that it was bid up to the price named above, but he would not allow it to go at that figure and he brought it home with him. Mr. Groff says that he was once offered \$12,500 for the watch. Owing to straitened circumstances he will take considerable less for it now. On the case of the watch is engraved "Ben Franklin, 1776." The relic was formerly worn by Richard Bache, of Bensalem, Bucks County, Pa., a son-in-law of the philosopher. On a visit to Philadelphia he left the watch hanging in the outhouse of a hotel, and never saw it again. This was early in the present century, and for many years the watch has been in the possession of Mr. Groff.

Canada.

J. E. Alexander, with the Whiting Manufacturing Company, and George Kendrick, with Reed & Barton were in Montreal recently.

James Eastwood, of New Glasgow, Nova Scotia, has been on a purchasing trip to New York, Boston and Montreal. He is a member of the Canadian Association of Jobbers in American Watches.

James Davidson, one of the Hamilton's most skillful manufacturing jewelers, has given up his Hamilton business and will engage with Henry Birks & Co., retail and manufacturing jewelers of Montreal.

E. J. Leahy, late with Smith Bros., Kingston, Ont., who some time ago started in the jewelry business for himself at Fort Thomas, Arizona, is meeting with good success. He has the good wishes of his Kingston friends.

There was a great time in the jewelry establishment of Ferguson & Page, St. John, N. B., the other day. An alcohol lamp had been overturned and for a moment it looked as if there might be a big blaze.

Archibald Bauer, the foreman of the establishment, took the source of danger up in his hands and ran with it to the yard where he placed it in the snow. His hands were badly burned and hlisters were raised on his wrists. Medical assistance, however, soon relieved his suffering.

There has been a large influx of Arab jewelry peddlers from the States within the past few weeks. The trunks of several of them containing large amounts of cheap jewelry are now detained by the customs authorities here. These peddlers all appear to be making for Nova Scotia, their trunks being checked for Amherst.

W. S. Walker, importer of diamonds and fine watches, of 1711 Notre Dame street, Montreal, is moving to the Nordheimer building, a more central location. More and more the downtown jewelry firms are centralizing about St. James street between St. Francis Xavier and McGill. Mr. Walker's rent will be \$2,500 a year. He will have one of the largest show windows on the street.

At Osgoode Hall, Toronto, the other day Justice Meredith heard a motion to discharge from custody W. F. Ross, who was arrested about a year ago on a capias at the instance of Schwab Bros., of Montreal, diamond brokers, and Anderson & Chillias, of Toronto. Ross was in business as a diamond broker at the time of his arrest. He was admitted to bail. Judgment was reserved.

Travelers from the wholesale jewelry house of J. L. Eaves, Montreal, are on the road as follows: Fred Addison, Ontario and the West; Harry Allan, Quebec; James Robertson, lower provinces and the Northwest. Mr. Robertson took a room at a leading hotel in Montreal for a week, like a visiting traveler, and sold a large quantity of goods, although his firm's headquarters were not many blocks away.

Messrs. Jules F. Courvoisier, Ed. H. Courvoisier, of Port Jarvis, N. Y.; Geo. W. Parent, Alex. Walker and Ald. Prefontaine, of Montreal, will apply to the Legislature at its next session to be incorporated under the name of "La Compagnie de Montres Courvoisier." The object of the New Company is the manufacture of gold and silver watches and other jewelry, and the capital stock will be \$40,000. Their place of business will be in Montreal.

Richard Hemsley's large store on St. James street, Montreal, has an attraction new for these parts. In a prominent place in the show window is a dynamo with a good current of electricity. On and near this are placed ordinary and non-magnetic watches. The non-magnetics tick steadily on, at the rate of sixty seconds per minute, while the ordinary watches present a very poor comparison. There is generally a large number of interested spectators.

L. H. Keller & Co., No. 64 Nassau street, N. Y., made arrangements a short time since, whereby they became sole agents for the United States, except New York city, for the Patek, Philippe & Co. watches.

Nutmeg Gratings.

Gen. Geo. H. Ford, the leading New Haven jeweler, increases each year his direct importation from Europe of choice novelties in jewelry, silver goods, bric-a-brac and antique goods, which he personally selects on his annual visit to the old world. He is one of the few New England jewelers making foreign importations, and is contemplating a more extended tour of the continent of Europe this season than usual, both for business and pleasure.

A curious and valuable relic, which the owner greatly prizes, is a watch made in England 99 years ago. It is owned by Hon. John Woodward Thompson, of East Haven. It has been in his family all these 99 years, and was brought to light a few days ago. Soon after the death of his mother it was found among her treasures which had long been packed away. On taking the venerable time piece to Gen. Ford's watchmaker, it was found to be in perfect running order, and needing no repair.

The discovery of solder for aluminum will probably result very profitably for the inventors, Frank T. Page and Henry A. Anderson, of Waterbury, they having received tempting offers, already. J. A. Hunt, president of the Pittsburg Reduction Co., has been in Waterbury negotiating for the purchase of the invention.

The new Brooklyn district school, Waterbury, will soon display to the admiring public of that enterprising city the face of a fine large tower clock, which is a gift to the city from Lake & Strobel, the jewelers there. It is a Seth Thomas clock, selected by Chris. Strobel, in New York, and Mr. Thomas will personally supervise placing it in position in the tower.

Julius C. Maltby has been elected secretary of the Maltby, Stevens & Curtis Co., of Wallingford, vice Samuel J. Bryant, who retires from the position after years of service. Mr. Bryant still remains a director of the company. The other directors (just elected) are D. F. Maltby, W. H. H. Wooster, I. T. Wooster, W. H. Fearing, J. C. Maltby and

E. S. Stevens. The directors are elected as follows: President and Treasurer D. F. Maltby; Secretary, J. C. Maltby; General Manager, E. S. Stevens.

A current story in Meriden to the effect that since the recent defalcations of two trusted employees of the Meriden Silver-plated Ware Manufacturers, Inspector Byrnes, of New York, has, at the solicitation of the companies, had a detective in Meriden for weeks past shadowing other employees, is denied by competent authority.

A. D. White, the New Haven jeweler, and auctioneer of jewelry, remains still very ill.

Boston.

Irving Smith, of Morrill Bros. & Co., who has been under the weather the past week, is out again.

Interior decorations have brightened up the establishment of H. T. Spear & Son since stock-taking.

The 12th of March has been fixed upon as the date for the ladies' night banquet of the jewelers at the Vendome.

Workmen have been busy at Nelson Brown's clock store, 92 Franklin street, since the fire of a fortnight ago, and the interior has resumed its wonted appearance.

In our last issue we mentioned Mr. O. C. Dow, who has taken a room next door to the office of the American Watch Company, is a shareholder in the Faneuil Watch Tool Company. Mr. Dow takes great interest in the prosperity of the company and the sale of its goods, but at present holds none of its stock.

The traveling men who were in town this week were George Paine, E. I. Franklin & Co., Walter H. Tarlton, with Wightman & Hough; Mr. Dickerson, C. W. Cary, with J. B. & S. M. Knowles, and S. O. Bigney, Providence; J. L. Shepherd, of the Keystone Watch Case Company; L. Lilienthal, of Bruhl Bros. & Co., and George Osborne, with William Smith & Co., New York; E. B. Eaton, with H. D. Merritt & Co., North Attleboro; A. B. Levinson, with Darlington & Schloss, Buffalo; Charles Fuller, of George H. Fuller & Son, Pawtucket; S. P.

Barbour, of Barbour Bros., Hartford, Conn.; Howard C. Rowbotham, of H. Muhr's Sons, Philadelphia.

Hartford.

Charles G. Hall, proprietor of a small jewelry store at No. 321 Main street, Hartford, Connecticut, has assigned to Uriah Case. His liabilities and assets have not been determined. A hearing for the approval of trustee will be held at the Probate Court.

Rev. Richard S. Eldridge, who a number of years ago retired from the ministry on account of poor health and became proprietor of the jewelry store No. 211 Main street, has returned to the pulpit. He has been appointed pastor of the Methodist church at Jewett City, and removed with his family to that place. The store is now owned by Ryan & Barrows, successful jewelers of Middletown.

Stern & Frank's Workmen Strike.

ON Thursday, the dozen or so workmen in the factory of Stern & Frank, 10 Maiden Lane, struck at the instigation of one of the workmen, Adolph Schleiper. Schleiper is a moving spirit in one of the jewelers' unions and advised his employers to raise the wages of the men specifying what each one was worth. Though the present season is one when working jewelers are in many cases laid off, Stern & Frank determined to keep their men at the bench, as had always been their practice. They did not see fit at first to raise the men's wages, but at length slightly augmented all of them, with one exception, the man's services hardly warranting the salary he was then getting. Schleiper insisted upon the salary of this man also being raised, and being refused he ordered the strike. As all union men they complied.

The entire force of workmen with two exceptions have never worked for any other house, and have always been satisfied. Many of them had returned to the bench at this writing. The statement that a watchman was placed over them is refuted by the firm. The man referred to acted only as time-keeper.

KEY CHAINS.

ROBT. H. INGERSOLL & BRO.,

65 Cortlandt St.,

Send for List.

NEW YORK.

 Geneva Optical Co.,
MANUFACTURERS OF
Spectacles, Eye
Glasses, Lenses
and Cases.
23 WASHINGTON ST.,
CHICAGO.



Have you seen our recent advertisement in the CIRCULAR, relative to Willson's Spectacles? Do you know that in consequence of our having purchased the largest quantity of Nos. 184 and 155 ever sold in one bill in the United States (so say the manufacturers) we are willing to sell 250 or 300 gross of them at about 20 per cent. below the regular prices? and that, in consequence, judicious buyers are sending in their orders from both sides of the St. Lawrence, and from ocean to ocean? Do you want to take advantage of this rare opportunity to buy staple goods at prices that may never be touched again? It is worth a postage stamp to find out about it.

Bowman & Musser,

Importers and Jobbers,

Watches, Chains, Spectacles, Tools and Materials,
Lancaster, Pa.

Chicago.

J. S. Gratz has gone East on a business trip.

Swartchild & Co. are remodeling and enlarging their store.

Sam Dripps, of Benj. Allen & Co., has gone South on a vacation.

Fred Heffron, of Riley, French & Heffron, has gone to San Francisco.

George Weidig, of the Brooklyn Watch Case Company, is in New Orleans.

A. Jampolis, one of Lapp & Flershem's men, has left for a trip through Nebraska.

Moses Goldsmith, of Goldsmith Bros., returned last week from a very successful business trip to New York.

T. B. Myers, of Myers & Co., of St. Paul, was in the city last week. He says business is good in one of the Twin Cities.

A. R. Hopkins, a well known jeweler of Mammoth Springs, Ark., was in the city last week. He purchased a large number of goods.

A. Kaempfer's jewelry store was robbed of a lot of valuable umbrellas last Wednesday night. The thieves hurled a large stone through the plate glass window, and then seizing the umbrellas made their escape.

Giles Bros. have a fat boy in their employ who might be considered a rival of Dickens' famous elephantine youth. Giles Bros' young man is about ten years old and his weight somewhere about 140 pounds.

The Chicago College of Horology on Feb. 20 removed from 320 Dearborn street to the southwest corner of Robie and Madison streets. The new quarters are spacious and are filled up in fine style.

Among the out-of-town jewelers who have been in the city transacting business with Lapp & Flershem, were J. A. Spurrier, of Rushville, Ind.; H. T. Thompson, of Buda, Ill., and Duncan Campbell, of Henry, Ill.

Mayo, Groff & Co., a corporation of retail jewelers doing business under the Palmer House, held an annual meeting a few days ago at which it was agreed to sell all of the stock to the active members. The officers are: J. B. Mayo, president; E. L. Groff, vice-president and treasurer, and H. S. Crump, secretary. The meeting was very amicable in its proceedings.

Treasurer Henshaw, of the Geneva Optical Company, who is in Florida in search of health, writes that he is improving rapidly. He says that he does not think much of Florida as a hunting ground. He tells how he went out to shoot snipe recently, and when he got to the swamp the first thing he saw was a rattlesnake seven feet six inches long. Mr. Henshaw killed the "rattler," but says he wouldn't hunt snipe in a Florida swamp again if each bird had a silver certificate for \$20 attached to its tail.

Jewelers and opticians have already begun to agitate the question of making displays at the World's Fair. Spaulding & Co., who had a magnificent exhibit at the Paris exposition, will try to excel it at the World's Fair. Other

large retailers will make exhibits. J. T. Brayton, of the Geneva Optical Company, and the inventor of the lens-measuring machine, will probably be the superintendent of the optical display at the World's Fair Exposition.

Bought Clothes With Jewelry.

ABOUT October 1, last year, Henry E. Oppenheimer & Co., 47 Maiden Lane, had a call for a diamond ring which had been left with them by a friend to have its setting altered. The firm could not find the ring and presumed that it had somehow been lost or sold by mistake. They then had no idea that there was thievery being committed. As time went by they could not help but noticing that certain articles of jewelry were missing. They also noticed that their stock clerk, Ferdinand W. Cahn, a young man of 22 years of age, whose salary though commensurate with the value of his services, was not large, was keeping pace with the reigning fashions in clothing and haberdashery and was living far beyond his means.

Last Friday a diamond ring was missed and was traced to Cahn, it being found in his pocket. He was questioned and he admitted that he had been stealing from the firm since last December. The case was reported at Police Headquarters, and Detectives McCluskey and Heard arrested the young man that night, while he was "shining" at a ball. The detectives accused him of stealing jewelry from his employers and he admitted the larceny. They accompanied him to his home at 117 E. 115th street, where he delivered to them fourteen pawntickets, representing diamond rings, earrings and studs, to the value of \$1,500, and acknowledged that they represented goods stolen from Henry E. Oppenheimer & Co. Nine of the tickets dated further back than Dec. 1.

Cahn was arraigned on Sunday morning, in the Jefferson Market Police Court before Justice Ford, and pleaded not guilty. He was remanded until 10 o'clock, the coming Saturday, in \$2,500 bail, which was promptly furnished by his mother, who is a widow in comfortable circumstances. The goods were redeemed from the pawnbrokers yesterday, to be identified by Henry E. Oppenheimer.

Cahn had been in the employ of Henry E. Oppenheimer & Co. for a year. As stock clerk he checked the goods received or delivered. The firm have a safe check and a counter check which had been thought to be perfect in their effect. As Cahn could destroy the records, his operations were comparatively easy. He is respectably connected, and considerable sympathy is expressed for his family, though the law will be allowed to take its course.

The trade must not confound the pilfering clerk with Felix Kahn, who has been for many years a salesman in the same house.

H. Oppenheimer's Loss.

A fire last Sunday night in Kansas City, Mo., resulted in a loss to H. Oppenheimer & Co. of \$70,000, partly covered by insurance.

The Attleboros.

Col. Horton, of Horton, Angell & Co., will go to Detroit this summer as a delegate to the National Encampment of the Grand Army from this State. This is the third or fourth time he has had the honor.

One of the best signs of business prosperity in this vicinity, is the fact that there is not the slightest talk of any embarrassment among the manufacturers, which is generally current at this time of year.

W. & S. Blackinton have just put in a new ventilating apparatus in their shop which is able to reduce the temperature of the building 20 degrees in half as many minutes. Some of the other shops need its operation badly.

Bates & Bacon are building an addition to their watch-case factory building. Part of the object of its erection is to brace the main building, which recent heavy gales caused to rock more than was comfortable except for infants.

Most of the opposition of the manufacturers to their employees being members of the local militia company has died out. The company stands at the head of the militia of the State, and the jewelers are beginning to take a little pride in it. It is said that one of the prominent jewelry manufacturers is going to offer a medal to be worn by the best-drilled man in the company.

News Jottings.

W. W. Moore has opened in the building next to the postoffice at Franklin, Va.

A Mr. Slackman has engaged room for a jewelry store in Sanderson's & Thompson's store at Orange, Mass.

W. E. Page has removed from Auburn-dale, O., to Toledo, same State, and has opened a handsome store at 321 Adams street.

Dueble Bros., Canton, O., will shortly remove their stock to the handsome new store that is being fitted up for them in the old Central Saving's Bank building at Toledo, Ohio.

The entire stock of Sherman S. Hathaway, the Massillon, O., jeweler, who made an assignment some time ago, will be sold at auction. The sale commenced last Wednesday morning.

A burglar broke into the house of Chas. Bachman, at Ottumwa, Iowa, on the night of February 15th. He narrowly escaped capture by Mr. Bachman, but got away with about \$100 worth of goods. A reward has been offered for the burglar's capture.

J. A. Limbach, representing the Aurora, Ill., Silver Plate Manufacturing Company, telegraphed his house last Wednesday that he was in the Illinois Central Railway accident which occurred at Jackson, Tenn., February 18th. Mr. Limbach lost all of his photographs and his flat ware roll, as the baggage car was burned up. He did not carry any other samples on this trip. He has traveled for the Aurora people four years and this was his first railway accident.

News Gleanings.

C. Robie, Williamson, N. Y., has sold out.
H. C. Akins has moved from Curtis, S. D., to Deadwood, S. D.

A. A. Burbank, Rochelle, Ill., has given a chattel mortgage for \$250.

J. R. Connell, Portsmouth, N. H., has given a mortgage for \$300.

The store of E. L. Marsh, Altoona, Pa., has been closed on an attachment.

N. L., Jennings, Churdan, Iowa, has been succeeded by Jennings & Harrison.

Fred. Dorn, a prominent jeweler of Genesee street, Buffalo, leaves for New York this week to purchase stock.

S. H. Baynard, a leading jeweler of Wilmington, Delaware, is the Republican candidate for mayor of that city.

B. F. Wood, of Arcadia, Fla., has sold out his drygoods and will henceforth make a specialty of jewelry.

C. W. Freeman, Scanton, Pa., is closing out his stock at auction preparatory to moving into his handsome new store.

John A. Stopf, a leading jeweler of Dunkirk, N. Y., is preparing to enlarge and greatly improve his store on Centre street.

M. M. Lowenthal, Los Angeles, Cal., has compromised with his creditors at forty cents on the dollar, three, six, and nine months' notes endorsed.

By a fire in Main street, Lockport, N. Y., last week, E. M. Richardson's jewelry stock was damaged. The loss is covered by insurance.

De Gontard & Reynolds, of Scranton, Pa., anticipating a dissolution of partnership, are auctioning off their stock. Walter De Gontard will succeed the firm.

An attachment for \$3,400 was secured against W. S. Reichenecker, a jeweler of Seattle, Wash., by New York and San Francisco creditors on February 7th.

Burglar Miles, the noted crook who robbed the jewelry store of C. D. Norton, of Gloversville, N. Y., last June, has been sentenced to the Auburn Prison for five years.

The store of J. D. Wiggins, at Farmer Village, N. Y., was burned out on the night of Feb. 10. Nearly everything was saved and the slight loss was covered by the insurance.

J. S. Roberts, of the Waterbury Watch Company, is making his spring trip and is in Pennsylvania and Ohio this week. He is introducing some new and very taking styles in gentlemen's and ladies' watches, such as have not been offered by this firm before. They are of silver, gold filled and aluminum cases. The aluminum cases are particularly pretty and unique.

About a dozen of the leading jewelers of Erie, Pa., have organized an association for mutual protection and social intercourse. The officers are: President, Edw. Hoffman; Secretary, Geo. A. Disque; Treasurer, H. T. Jaricki. The association is already in a flourishing condition, and has accomplished

some good. Among other things, a uniform scale of prices for repair work has been established, and an imperative rule has been made that all repairing must be strictly cash.

The local silver stores in Buffalo, N. Y., have now a spoon which should be a joy to collectors of sentimental dozens. They may now add to the bear-spoon of Barne, or the stork of Strasburg, the Niagara Spoon. On its handle is engraved the Falls and the great torrent of water thunders down the stem into the bowl below in a manner at once realistic and impressive. These spoons are fashioned several shapes, among which is the twisted, distorted pattern known as the "witches' spoon," formerly affected by the eccentrics of Salem.

New York Notes.

Hipp Didisheim left Havre for New York, last Saturday on *La Champagne*.

Freudenheim & Abramson, Elmira, N. Y., have opened an office at 21 Maiden Lane.

Dattelbaum & Friedman have secured a judgment against Anton Scheiber and others for \$89.

The Spencer Optical Mfg. Co. has secured a judgment against Nathan Bachrach for \$661.34.

Jacob Muhr, of H. Muhr's Sons, Philadelphia, sailed to Europe Saturday on the *Etruria*.

Ferdinand Bing and N. Glauber (Grinberg & Glauber) arrived from Europe last week on *La Bretagne*.

Wm. Reiman will shortly move from 7 Astor House to the northwest corner of 31st street and Broadway.

The plans for the new building at 21 and 23 Maiden Lane were last week passed by the building department. The structure will cost \$100,000.

R. A. Breidenbach will about April 1, move from 26 John street to 51-53 Maiden Lane where he will occupy a large back office on the first floor.

Word was received in the city on Friday that H. S. Porteous, of Denver, Col., who recently failed, was on that day arrested as he was about to start on a trip to Scotland.

On March 1, Leopold Stern, United States agent for the Wurt Electro-Plate Company, Wurtemberg, Germany, will move from 41 Maiden Lane to the store at 44½ Maiden Lane.

A special meeting of the stockholders of the L. A. Cuppia Manufacturing Co. is called for March 10 at the company's office, for the purpose of determining whether the capital stock shall be increased from \$20,000 to \$30,000.

A. Wittnauer has brought an action against Jens F. Pedersen for about \$700, the value of goods sold and delivered to him by J. Eugene Robert & Co., of whom Mr. Wittnauer is the successor. Mr. Pedersen claims he does not owe the debt. The case has been set down for March 6.

M. de M. Marsellus, and A. S. Pitt have formed a partnership under the firm-name of Marsellus & Pitt. Their business will be the importation of precious stones and pearls, with an office at 18 John street. Mr. Marsellus was formerly with Carter, Sloan & Co., and recently with Charles Magnus.

Lieutenant Mason A. Shufeldt sailed on the *Celtic*, Saturday, en route to Africa as special commissioner for the World's Fair to be held in 1893. Among other enterprises it is his intention to have represented at the Exposition will be a diamond mine in operation, the mine to be furnished by Chicago, and the workmen and crude diamonds by Cape Colony.

The report published in the daily press that the whereabouts of Albert Jahn, who in December last absconded with jewelry valued at about \$28,000, had been discovered, was totally without foundation. David Marx who, according to the report, furnished the information to the reporter, declares the whole story to be a fabrication, as he had no claim whatsoever against Jahn and never heard of him until the time of the theft.

The incorporation papers of the Aikin Lambert Jewelry Co. were filed last week with the following names as officers: James Aikin President, John B. Shea, vice-president, Henry A. Lambert, treasurer, Fred. D. Ilgen, secretary, Samuel B. Mann, general manager. The company is an offshot of Aikin, Lambert & Co. and will conduct the firm's jewelry and watch departments. The gold pen department will remain unchanged under the old name of Aikin, Lambert & Co.

On Wednesday, the New York Jewelers' Board of Trade received from Wm. D. Dreher, Knoxville, Tenn., \$2,498.72 in cash and \$3,748.18 in notes to settle the claims of the Board's members against him on the basis of 75 per cent. net. The note bears six, twelve and eighteen months, time, the two first being endorsed. Mr. Dreher failed last December with liabilities of about \$25,000. The Board of Trade are thus to be commended for the speedy and satisfactory settlement they effected.

On the request of their counsel, Commissioner John A. Shields in the United States Circuit Court, on Wednesday last, adjourned the examination of Charles A. Bailey and John Tiedman of the Chicago Watch & Jewelry Co., who were arrested at the instance of Anthony Comstock for violating the lottery laws, as reported in THE CIRCULAR, until to-day. Justice Hogan at the Tombs Police Court on Saturday adjourned the examination in that court until 10 o'clock, February 28. The company have surrendered H. H. D. Klinker, their manager.

Ever on the alert for new attractions, M. B. Bryant & Co., 10 Maiden Lane, have patented a novelty in birthday rings, consisting of a tray in which they have arranged forty-eight rings, four for each month, with the month, the stone appropriate to it and the conventional sentiment in gilt letters. It makes a very handsome window display and will help the sale of the goods, as the well-known "Bryant" initial ring tray has stimulated the demand for that ring.

An Expert Jeweler and College Professor.

EDWARD SPENCER, A. B., Vice President and professor of Latin and Greek in Moore's Hill College, is probably the only man in the United States who can claim to be an expert jeweler and at the same time a college professor. Prof. Spencer was born in Iowa in 1863. At the age of fifteen he learned the jeweler's trade and worked at the business four and a half years. He then entered De Pauw University where he was graduated in 1888. He was then elected Professor of Language in Moore's Hill College and then Vice President which position he still holds.

Prof. Spencer has never forgotten his first love and is still an enthusiast in the line of horology. He frequently treats his students to scientific lectures on chronometers and other instruments connected with the subject. One lecture has been given on clocks, another on watches and other will follow on "jewelry" and apprenticeship experience.

Prof. Spencer unites with these qualifications the qualities of a Christian gentleman. He is an honor both to the institution with which he is connected and the jewelry trade.

Smuggled Jewels Forfeited.

PHILADELPHIA, Feb. 16.—The claim of the Government to forfeit the \$1,300 worth of diamonds and jewelry which David Squires attempted to smuggle in September, 1889, on the *Lord Clyde*, came before the United States Court to-day. Squires served five months for the offence. A portion of the goods, it was contended by his counsel, Henry R. Edmunds, belonged to Squires, having been manufactured in this country. A few of the goods were withdrawn from the case, but the bulk of them, under a verdict rendered by the jury, were forfeited. A time will be set for making public sale of them.

Syracuse.

J. W. Pierce, with Joseph Seymour Sons, is on a western business trip in the interest of the firm.

A recent fashionable event was the marriage of Miss Nellie Lathrop, eldest daughter of E. G. Lathrop, of the old established firm of Becker & Lathrop, to William Merritt, of Auburn, N. Y.

E. B. McClelland, who has been in New York, for several days past, will join Mrs. McClelland in Chicago, where she is visiting at her former home, and they will return home in about a week.

Frank H. Wells, successor to J. Dean Hawley, Son & Co., is making extensive preparations toward the remodeling of the store just purchased by him, and when completed it will be one of the finest jewelry establishments in Central New York. Mr. Wells hopes to have the changes made and ready for an earlier opening.

N. D. Prentiss, representative of Alling & Co., when travelling through the West, recently met J. N. Slutterd for many years

with Gen. J. Dean Hawley, in this city, and now in a responsible position with the leading jewelers of Salt Lake City. He also met James Ormesbee formerly a well-known jeweler in Syracuse, who has also located in Salt Lake City.

Among the representatives of manufacturing and jobbing firms in town the past week were the following: Stephen Woods, with the Leroy W. Fairchild Co.; H. C. Barnum, with Shafer & Douglas; H. R. Shirley, representing the cut-glass house of C. Dorflinger & Sons; E. L. Bearse, with H. G. McFadden & Co., fancy goods; Mr. Samuels, representing the L. A. Cuppia Manufacturing Co.; W. P. Melcher, with Shoemaker, Pickering & Co.; N. D. Prentiss, with Alling & Co.; Mr. Beach, with the Derby Silver Co.; Mr. Brown, representing A. R. Geoffroy & Co., and W. Kaiser, with Enos Richardson & Co.

Jacob R. Levinson, formerly a jeweler in this city, whom so many Syracuse people know to their sorrow, and whose arrest was noted in the last issue of THE CIRCULAR, will not return to Syracuse right away. It was supposed that everything bade fair to his case being settled in Syracuse courts, but fate in the shape of a Chicago judge ruled otherwise. About ten days ago a deputy sheriff left for Chicago with the papers that were thought necessary to secure a requisition and bring Levinson back to answer the numerous charges against him but habeas corpus proceedings prevented an immediate return. The case was called last Tuesday, and the justice decided that it had not been proven by the affidavits that Levinson had converted the goods to his own use, or that there was any evidence that the owners had made any demand for the goods. He was then discharged from custody. The proceedings which allow Levinson to escape are commented upon by the authorities here as very strange. It is asserted that the decision was purely one for Syracuse courts to decide. Levinson is about \$1,200 richer.

Indianapolis.

Mr. Trewin, representing the Keystone Watch Case Co., of Philadelphia, and J. L. Lake, with the Waltham Watch Company, were in town recently.

It is said that Horace Comstock, who is in a row of jewelry stores on East Washington street, has decided to close out his business. He will probably seek an opening in the new state of Washington.

Joseph Meyer & Co., who already do a large business in two pawnbrokers' shops on Illinois street, have leased a business room on East Washington street, and will open up a regular jewelry store.

A Bold Robbery.

PHILADELPHIA, Feb. 16.—A bold robbery on one of the principal business streets of the city was committed on Saturday night, when a glass case containing jewelry was carried off by thieves early in the evening.

About 7:30 o'clock on Saturday night a boy employed by William Silverston, a jeweler, No. 1013 Walnut street, found that the show case in front of the shop, containing about \$100 worth of jewelry, had been stolen.

The boy notified a policeman, but no trace of the robbers could be found. It is thought that they had a wagon and placed the show-case in it and drove away. The police are trying to locate the thieves.

Providence.

L. W. Pierce, of L. W. Pierce & Co., has recently discharged a \$600 mortgage.

John A. Keane, salesman for Ostby & Barton, was in Omaha last week.

R. Bradley, of R. Bradley & Sons, is slowly recovering from his recent severe illness.

E. S. Luther, of E. S. Luther & Co., has returned from a successful Southern trip.

The Howard & Son Company have been making extensive office improvements.

John Fuller, of Hagan, Fuller & Co., has started West in the interest of his firm.

Albert J. Smith, formerly of Mackinney, Smith & Co., is reported dangerously ill in Colorado.

John A. Lane, representative in the West for Palmer & Capron, was in Minneapolis last week.

Albert Eddy, of Albert Eddy & Co., who has been dangerously ill, is reported to be improving.

Charles W. Clough has leased and will move into the new store in the Sheldon Building, Pawtucket.

Among the firms in this city who are working nights is that of Fred R. Pennell & Co., 67 Friendship street.

C. A. Lyons, buyer for Cahoon & Robbins, of New York, visited the manufacturing jewelers in this city last week.

John Dodd has gone West for the Howard & Son Company. This trip will be confined principally to the Pacific slope.

The Holmes Manufacturing Company is the name of a new firm for the manufacture of fancy and taper wire recently started at 119 Orange street.

Two of the most energetic workers in the State Legislature are Hiram Howard, of the Howard & Son Company and William J. Feeley, of Feeley & Co.

Reuben A. Coombs has by mutual consent retired from the firm of Coombs, Tuttle & Stark. The business will be continued by John H. Tuttle and Asher A. Stark at the same place, 42 Point street, under the firm name of Tuttle & Stark.

S. K. Merrill & Co. have leased the third floor of the S. B. Champlin Building, 74 Chestnut, corner Clifford streets, and will remove from Pawtucket at an early date. Merrill & Co., moved from this city to the Bloomer Building, Pawtucket, on June 11, 1888, but owing to the difficulty in procuring help have decided to return to this city,

Benjamin F. Merrill, jobber, has started on a ten week trip West.

The Ladd Watch Case Company has given a \$50,000 mortgage upon real estate.

J. H. Bougartz has removed from 57 South Main street to 46 Winstickenden street.

Tilden, Thuber & Co. has a large line of Castilians, the new shell hair ornaments.

The Eastern Jewelry Company is the name of a new firm started at 235 Eddy street.

Albert Ohler, of Ohler & Co., visited New York, Philadelphia and Baltimore last week.

Edward Luther, of E. S. Luther & Co., visited New York and Philadelphia last week.

E. A. Mitchell has purchased the retail store of G. A. Hlicks at 19¹/₂ Plainfield street.

Walter A. Peck has been elected a director of the Rhode Island Investment Company.

Ohler & Co., of this city, will be represented on the market this season by Albert A. Fisher.

William Pimm has been elected Marshall of Rhode Island League No. 1 of the Protective League.

A bill has been presented in the State Senate to incorporate the J. B. & S. M. Knowles Company.

Nelson S. Davis has so far recovered from his recent illness as to be able to be in the market once more.

The Goldsmith Manufacturing Company have opened an office in the Swartz Building, 87 Weybosset street.

Edward W. Watson has been elected secretary of the Rhode Island Division of the Travelers' Protective Association.

William Ballou, a jeweler in the employ of George H. Cahoon & Co., committed suicide last week by shooting himself.

Nathan Barton, of Ostby & Barton, has started on an extended southern and western trip.

Richard Bradley, of R. Bradley & Son, who has been seriously ill for several months is now convalescing.

A. Fitzgerald will represent A. B. Day & Co. on the road during the illness of their regular salesman.

Stephen C. Howard has been elected a member of the Executive Committee of the Providence Press Club.

David Bernkopf, of Leeder & Bernkopf, sailed Saturday on the La Gascogne, for Europe in the interests of his firm.

Charles Downs is selling out his stock, tools and machinery preparatory to retiring from the jewelry business.

John M. Chandler, of the J. M. Chandler Co., of this city, has been in Cleveland, O., several weeks on business in the interests of his firm.

Steady and increasing business is the report of Ostby & Barton, and they are obliged to keep two hundred hands busy ten hours a day to keep up with their orders.

The regular monthly meeting of the directors of the Manufacturing Jewelers' Board of

Trade will be held on the 21st inst., in their rooms in the Wilcox Building.

John Klipper, of New Orleans, who was burned out about three months ago, was in town recently endeavoring to arrange for a settlement with his Providence creditors.

Among the jewelers in town the past week were: R. A. Kipling, New York; John Kippler, New Orleans; J. J. Cohn, New York and W. S. Shuttle, Dallas, Texas.

Worcester & McDonald, 120 Friendship street, have purchased the electro-plating business of G. L. Greene & Co., which they will continue in connection with their own.

Edgar L. Logee, formerly of the firm of R. L. Moorhead & Co., has commenced business in the Fitzgerald Building, on Eddy street, under the firm name of E. L. Logee & Co.

A bill to incorporate the Jewelers' Beneficial Association of Rhode Island was introduced in the General Assembly last week and was referred to the Committee on Corporation.

The fire insurance adjusters on the Lederer Building fire met Tuesday morning and appointed a committee consisting of John McWilliams, L. S. Winchester and Messrs. Hess, Reid and Gnot to estimate the damage on building, stock, fixtures and machinery. It will probably take several days before a settlement is made.

Mr. Ralph S. Hamilton, Jr., of Hamilton & Hamilton, Jr., has been very busy since the 6th inst., presenting his numerous friends with fragrant Havanas upon the advent of a ten and a half pound young lady who has taken up her home with Mr. Hamilton's family. Mother and daughter are getting along nicely, and papa is as happy as can well be imagined.

H. Ludwig & Co. have been making extensive alterations in their new factory, corner Blackstone and Gay streets, by the addition of a coloring room, with batteries, dynamo and all necessary appurtenances of coloring and electro-plating, at an outlay of about \$2,500. Mr. J. Staples has been engaged to take charge of this department. This firm is now employing about 150 hands.

Charles E. Hancock, of Hancock, Becker & Co., who has been in this city for some time arranging his line of new samples started Wednesday on a Western trip which will be extended as far as the Pacific Slope. His route will be New Orleans, Los Angeles to and San Francisco; returning by way of Denver, Salt Lake City and the northern route. He is accompanied by his wife and will combine business with pleasure.

Only Three Copies Missing.

CHAS. A. BECK, of Franklin, Ind., offers to pay one dollar for a copy of each of the October and December, 1885, and January, 1886, numbers of THE JEWELERS' CIRCULAR.

If anyone having these issues to spare will send them to Mr. Beck, he will pay that amount for each.



A Bit of Reminiscence.

BROOKLYN, Feb. 18, 1891.

To the Editor of *The Jewelers' Circular*:

In your issue of the 11th inst. I notice among "News Gleanings," an article claiming the watch factory at National City, which lies ten miles south of San Diego, California, to be the first and only institution of the kind on the Pacific Coast.

It may be the only one now, but it is not the first one. Early in the seventies the lamented W. C. Ralston, then Cashier of the Bank of California, induced Mr. Cornell, of Chicago, Ill., to remove his factory to the Pacific Coast. A company was then duly organized under the name of the Cornell Watch Company, and, if I remember right, Mr. Cornell was its president and manager, and the Bank of California its treasurer. It had its offices and factory in the old Kimball building on Fourth street, between Harrison and Bryant streets, San Francisco. Subsequently Mr. Dirking, No. 128 Kearney street, San Francisco, became the general agent. When the tragic death of Mr. Ralston occurred in 1876, the Cornell Watch Company tottered so much that several capitalists such as Captain Oliver Eldridge, Col. Peter Donohue, Mr. N. H. Spaulding and others reorganized the company under the name of the California Watch Company, and Mr. Spaulding became its president. Its office was No. 134 Sutter street, San Francisco, and its factory was removed to Berkeley, Alameda county, a building being erected for its accommodation, facing almost the entrance to the Golden Gate. This building became afterwards a shoe factory. But the new enterprise was of short lived duration and proved disastrous to employees and stockholders alike. At that time I undertook to interest the Japanese Government in the enterprise, intending to buy up the plant of that watch factory and remove it to the vicinity of Tokio, Japan. But the greediness of some parties prevented, and later the plant was removed to Chicago or vicinity, where it may be used to manufacture a superior watch to anything ever made in California.

CALIFORNIAN.

More About Optical Organization.

TRENTON, Feb. 20, 1891.

To the Editor of *The Jewelers' Circular*:

DEAR SIR:—As I was one of the first two men to avail myself of the opportunity offered opticians to take systematic instruction in optics by Dr. Bucklin in 1887, I read Mr. Parker's suggestions in your journal with great interest, and I also am heartily in favor of forming a Post Graduate Association of Opticians.

I think that all skilled opticians interested in the progress of optics should become members of this association upon the endorsement of two members of the society. Doctor Bucklin's students, now numbering over two hundred, come the nearest to being an organized and harmonious body of skilled opticians, and as such should initiate this movement. The object of the society should be strictly scientific, and trade interests should be excluded, thus showing justice to all and partiality to none.

The meeting should be an annual one at which papers should be read and discussed by the members.

Corresponding members living at great distances could submit their essays, and have them read and discussed at the meeting, the conclusions arrived at by the discussions being published.

If those interested in the organization of this society will communicate with me a meeting will be called in New York in March, when the necessary steps of organization will be taken.

Respectfully yours,

GEO. F. APPEGATE.

GORHAM MFG. CO.

Silversmiths.

SOLID SILVERWARE.

Manufacture and carry in stock the largest assortment of Solid Silver Ware to be found in the country, including specimens of art work of the most elaborate and costly design, as well as articles of plainer and more simple forms suitable for household use.

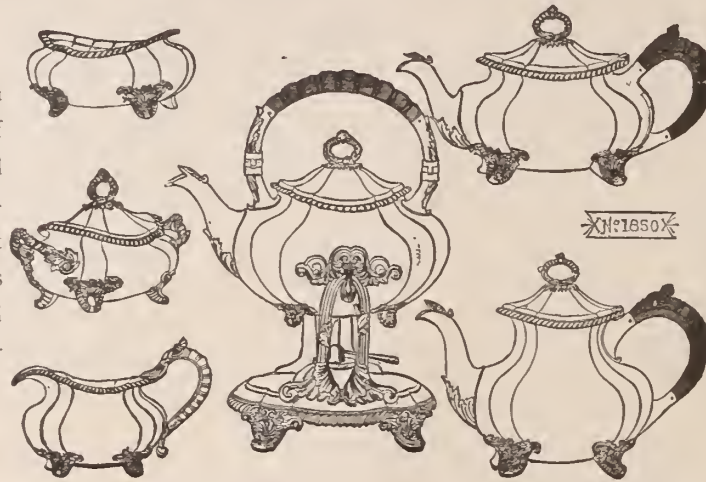

Gorham Mfg. Co.'s Branch Houses:
 9 Maiden Lane, N. Y.
 137 & 139 State St., Chic., Ill.
 120 Sutter St., San Fran., Cal.
 36 Avenue de l'Opera, Paris,
 France.

WORKS: PROVIDENCE, R. I

ALL COMMUNICATIONS SHOULD BE ADDRESSED,

Broadway and 19th St., New York.

ALFRED H. SMITH & CO.,

DIAMONDS,

182 BROADWAY,

COR. JOHN STREET, **NEW YORK.**

33 HOLBORN VIADUCT, LONDON, E. C.

THE JEWELERS' CIRCULAR AND HOROLOGICAL REVIEW.

PUBLISHED EVERY WEDNESDAY BY

THE JEWELERS' CIRCULAR PUB'G CO.,

AT NO. 189 BROADWAY, NEW YORK CITY.

Members of the American Trade Press Association.

A JOURNAL DEVOTED TO THE INTERESTS OF WATCHMAKERS, JEWELERS, SILVERSMITHS, ELECTRO-PLATE MANUFACTURERS AND ALL WHO ARE ENGAGED IN KINDRED BRANCHES OF INDUSTRY.

Terms of Subscription, Postage Prepaid.

	PER ANNUM
United States and Canada, - - -	\$2.00
To all Foreign Countries, - - -	4.00
Single Copies, - - - - -	.10

ADVERTISEMENT.

Business letters, drafts, checks and post-office orders should be addressed to THE JEWELERS' CIRCULAR PUBLISHING COMPANY, No. 189 Broadway, New York city.

Manuscript from any quarter containing news or discussion of any technical subject within the field covered by THE CIRCULAR will be welcomed. Matter received that proves unsuitable or unavailable will be returned if accompanied by the necessary postage stamps.

Our editorial columns will contain our own opinions only, and we shall present in other columns only what we consider of interest or value to our readers. Applications to print advertising matter as news will not be considered.

Advertising rates in THE CIRCULAR are lower, considering the number of tradesmen reached by its large circulation, than in any other jewelry journal.

Notices of changes in standing advertisements must be received one week in advance, new matter can be received up to Saturday.

VOL. XXII. FEBRUARY 25, 1891. No. 4.

A Word About Organizing.

SOME of the leading jewelers of Erie, Pa., have formed an association for mutual protection and social intercourse. Already, they have established a scale of prices for repairs, and have ruled that all such work shall be done on a cash basis. This is well. Organization of any kind, properly managed, invariably leads to benefit to the organizers. Not long ago a number of jewelers of a Southern city agreed to make purchases together so far as possible, to keep familiar with the cost prices of goods thus bought and to adopt a uniform scale of retail prices for the same. The plan worked well, and there was no underselling among them.

It is not reasonable, and it is not right, that a customer should find in one store an article marked a certain price and in another store the same article selling at a different price. It leads to distrust both of the goods sold and of the honesty of the merchants selling them. A uniform price list would go far toward exterminating much injurious competition, and would tend

toward building up and strengthening the retail trade.

There is too little of organization among jewelers and THE CIRCULAR commends and recommends more of it.

In the matter of repairing much can be said in favor of a uniform price. At present the man who wants a watch repaired can have a different quotation on the job for every shop he takes it to. Not long ago a man in this city got five quotations varying from fifty cents to \$3.50 on the same repairs to a watch. If a uniform price were adopted there would be none of this, customers would have more confidence in the repairer and at the same time be content to pay a fair price for good work.

From Work-Bench to Professor's Chair.

THE fact, published in another column, that a man who has worked at the jeweler's bench both as an apprentice and a journeyman is now the vice-president of a college and its professor of Latin and Greek, may encourage many a jeweler's apprentice whose soul is fired by scholastic ambitions. The man referred to is Edward Spencer, A. B., of Moore's Hill College.

He is not ashamed, either, of his early work at a trade. He pursued his studies in horology until he became an expert horologist and now he spends time and energy in preparing and delivering to the students' lectures on that subject which are not in the college curriculum.

Making and repairing clocks and watches is but work-a-day employment, out of which few rise to such a height as Professor Spencer. But what he has done has been done by workers at other trades also, and can still be done by workmen who are willing to strive for higher things and who are capable of performing them. Still, it is to be hoped that the example of Professor Spencer, thus made public through THE CIRCULAR, will not result in making vacant all the work-benches in the country, and thus render horology a lost art because all who were engaged in it have become college professors.

Jewelers, Keep Informed.

THE story that Samuel Meyer, of Clifton Forge, Va., tells the police is of interest to every jeweler in the country. A negro, armed with an infernal machine of some sort, entered Meyer's store and engaged him in a business way. He then endeavored to fill the air with an odor emanating from his machine, purposing to rob the store during the proprietor's helplessness, which was to be superinduced by the effects of the odor. By rapid and intelligent action Meyer defeated the negro's purpose and thereby saved his goods.

Such a scheme as this is not by any means common, but rogues are constantly endeavoring to hatch new schemes for robbing jewelers. Therefore, jewelers should be always on the alert to detect the first ulterior intent in a prospective customer, and thus be the

better prepared to frustrate dishonest action. To do this he should be up with the times and familiar with every plan attempted, be it successful or unsuccessful. THE CIRCULAR will endeavor to publish news of every such attempt, and its subscribers, by thus keeping informed of the methods used, can be well-prepared to defend their property against the efforts of dishonest persons.

SOUVENIR spoons seem to be the craze in many sections of the country, and dealers Souvenir Spoons. are constantly kept busy planning new designs to meet the popular fancy. To such an extent is the "fad" spreading that it will soon be the proper thing for the tourist to return from his travels with a satchel whose contents shall resemble those of the sample case of a drummer for a silverware house. But all fancies of this sort that come to the jewelers' mill are good grist, and it is certain that our tradesmen will find no fault if every baby of the coming generation should be born, not with a silver spoon in its mouth, but with one ready and waiting to satisfy its infant crying with pap. Much skill in the engraving, as well as in the shaping of these souvenir spoons has been exercised, many of them being not only unique but beautiful. One of the latest is the "Niagara" spoon, which bears upon its surface a representation of the great falls tastefully and artistically executed. They are things of beauty and a joy—while the craze lasts.

McBride and Marcellus in the Sheriff's Hands.

CLEVELAND, O., Feb. 21.—The wholesale jewelry house, doing business under the name of the McBride & Marcellus Co., 204 Superior street, was taken possession of by the sheriff to-day on a cognerit judgment for \$10,000 in favor of L. P. Penfield. Marcellus had already made application for a receiver, but the sheriff arrived at the store first and took possession. The officers of the company are: D. H. McBride, President; C. E. Marcellus, Vice-president, and J. L. Noonan, Secretary and Treasurer. They are at odds, and an interesting tangle is likely to ensue.

The firm of McBride & Marcellus was organized about 1884 as Gracie & McBride, and did an instalment business, Gracie selling out the following year to McBride & Marcellus, who continued the instalment business until early in 1889, when the incorporation of the McBride & Marcellus Co. was formed to engage in the retail and wholesale business. They have been running a branch store at Cuyahoga Falls, in charge of George Goble. The concern has always had a fair credit and the present trouble, due undoubtedly to internal dissension, was entirely unexpected.

A meeting of the creditors of Sumner Bros., Cleveland, O., who failed some months ago, is called for to-morrow, at the rooms of New York Jewelers' Association, for the purpose of effecting a settlement if possible.

New York Notes.

(Continued from page 213)

J. Horowitz has secured a judgment of \$117.90 against Max Solinsky.

Max Frankel has satisfied a judgment to Henry E. Oppenheimer & Co. for \$85.77.

B. H. Davis & Co. have secured a judgment against Charles Magnus for \$391.67.

The store of George A. Miller, at 37 First avenue, was sold out at auction on Thursday last.

A judgment was last week recorded against C. L. Rabitte for \$116.71 in favor of E. B. Bullock.

The office of the Dueber Watch Case Manufacturing Company at 178 Broadway is closed and advertised to let.

The Manhattan Railway Advertising Co. have secured a judgment for \$635.39 against the Riley-Osborne Manufacturing Co.

S. F. Myers, of S. F. Myers & Co., sailed last Saturday on a trip to the West Indies. During his absence he will visit the Jamaica Exposition,

Vincent W. Henderson, for five years with Simons, Bro. & Co., has been engaged by Shafer & Douglas, to look after the city and near-by trade.

On Wednesday night thieves broke into the work-shop of Baxter & Harris, repairers, 306 Washington street, Brooklyn, and carried away four watches valued at \$80.

Dr. L. A. W. Alleman, M. A., delivered a lecture on "Optics" before the Brooklyn Ethical Association, last Sunday, in the Second Unitarian Church, Brooklyn.

L. Grinberg, formerly of the Novelty Manufacturing Co., 32 Maiden Lane, is now in business under his own name as dealer in diamonds and precious stones at 51 Maiden Lane.

The action for \$5,000 damages brought in the Court of Common Pleas by the New York Standard Watch Company against Austin Corbin, was last week amicably settled out of court.

On Thursday afternoon the jewelry district wore the solemnity of a holiday, as the major part of the stores and offices closed in respect for General William Tecumseh Sherman, whose funeral took place that day.

The case of Samuel Bock, charged with stealing a ring entrusted to him by Adolph Cohn, 1442 Third avenue, as recently reported in THE CIRCULAR, was brought up before Recorder Smyth in Part II. of General Sessions, on Feb. 20, and was adjourned to Feb. 26.

Albert Schlegel, of 535 Wythe avenue, Brooklyn, indicted on the charge of larceny in stealing goods from A. Frankfield & Co., who had employed him for ten months as manager of their watch department, on Friday last pleaded not guilty before Judge Cowing in Part I. of the General Sessions.

On May 1, Henry Abbott will move from No. 4 to No. 14 Maiden Lane, where he will occupy the east side of the store of E. G.

Webster & Son. He will have much larger quarters than at present, and besides manufacturing his stem-winding attachment, will carry a line of diamonds and watches.

The twenty-fifth annual banquet and ball of the New York Uhrmacher Vereins will take place at the Teutonia Assembly Rooms, on March 15. The officers of the organization are: F. Riecker, President; B. Schmaus, Vice-President; E. G. Baur and R. A. Stoehr, Secretaries, and L. Schieck, Treasurer.

Charles L. Rabitte, 437 Broadway, who recently became insolvent, and transferred his business to his wife, is endeavoring to effect a temporary settlement with his creditors, who are mostly Providence manufacturers, on the basis of 33 1/3 per cent. on six, nine and twelve months' notes. His liabilities are about \$4,000. He is advertising a clearing-out sale of his jewelry.

On Wednesday night the shop of Baxter & Harris, repairers, at 306 Washington street, Brooklyn, was broken into, and four watches valued at \$80 were stolen. On the next day Theodore W. Wells, aged twenty-seven, a member of the Thirteenth Regi-

ment, was arrested for the crime. He acknowledged the theft, and in the Adams Street Court was held for the Grand Jury.

The sheriff's sale of the property of the New York Smelting and Refining Company, of 506 West street, under executions issued against the concern in favor of the First National Bank, has been postponed until today in order to give the company an opportunity to arrange matters. The affairs of the company have been placed in the hands of the creditors and a settlement is expected to be effected.

The trial of Albert Neidermann, of Philadelphia, who was arrested on his arrival from Europe, December 27 by staff officer, Storey and Inspector Browne of the Barge Office for smuggling, is expected to take place this week before Judge Green in the District Court at Trenton, N. J. The appraisal of the goods smuggled and which have been forfeited to the government (foreign valuation) has just been made. It is: Watches (foreign valuation), \$666, duty (25 per cent.), \$166.50, home valuation, \$832.50; jewelry, \$399.50, duty (50 per cent), \$199.75, home valuation, \$599.25., Total, foreign valuation, \$1,065.50; home valuation, \$1,431.75.

◆—DIAMONDS—◆

Our Diamond Stock in the future will be separated into twelve grades, as follows:

- A. Blue-White and Perfect.
- B. " " " Imperfect.
- C. Extra White and Perfect.
- D. " " " Imperfect.
- 1. White and Perfect.
- 2. " " Slightly Imperfect.
- 3. " " Imperfect.
- 4. Very Good Color and Perfect.
- 5. " " " " Slightly Imperfect.
- 6. " " " " Imperfect.
- 7. Good Color and Perfect.
- 8. " " " Imperfect.

Copyrighted August 15, 1890.

Copyrighted August 15, 1890.



Each piece in addition to the regular number will have one of above letters or numbers to indicate the quality of the diamond. This will give you the benefit of our judgment as to the grade and quality of each stone, and, we believe, will help you in the purchase and sale of diamonds from our stock.

When in need of anything special in diamonds, send to us for an assortment on selection. Don't hesitate because you may never have had any previous dealings with us, as we should be glad to have you for a customer and to have you give this new grading system of ours a trial.

J. T. SCOTT & CO.,

4 MAIDEN LANE.



NEW YORK.

Springfield, Mass.

L. S. Stowe & Co. are making alterations in the store, in order to provide an office for Thomas N. Glover, a graduate optician.

M. G. Ormsby, who has been with J. E. Caldwell & Co., Philadelphia, has taken a position with A. E. Hathaway, of this city.

C. Rogers, the optician, has leased the store at No. 481 Main street, now occupied by J. H. Butterfield, and will take possession of it April 1.

The Charles Saxton Co. have made some souvenir spoons, with the word "Springfield" in the bowl, and a representation of the old Springfield rifle on the handle. These spoons are meeting with a ready sale here.

Stowe & Co. have copyrighted designs for souvenir tea, orange and coffee spoons. The bowl is plain while on the handle is a representation of the statue of Miles Morgan, one of the early settlers of this State; also the word "Springfield." The bowl of the orange spoon is gold lined.

Norfolk.

Mr. Chapman, of Chapman & Gale, who has been ill about a week with a severe cold, is again at his place of business.

George Smith, who succeeded his father S. Reeves Smith, the Bank street jeweler, who was killed some time ago by a runaway horse, contemplates a trip to New York, and other northern cities, to lay in his spring and summer stock.

Samuel Meyer, the proprietor of a jewelry store at Clifton Forge, Va., told the police of that city a peculiar story last week. He said he was busy around his store quite late one night, when a colored man entered and asked for something that was difficult to find. The buyer seemed to be edging toward the cash drawer. Suddenly he placed a little round box on the edge of the counter. A moment later the air was filled with a most oppressive odor. It made Meyer faint and he believed himself to be in the hands of one who meant him harm. He tried to cry out, but was too weak. Gathering his strength he made a leap for the glass in the window. The fresh air revived him, and the colored man seeing his device had failed drew a revolver and covered Meyer while he backed out to the door till he reached the street and escaped.

Liquor for Cleaning Silver.

The following solution will be found to produce a high brilliancy in silver work: Cream of tartar, 30 parts; sea salt, 30 parts; sulphate of alumina and potash, each 30 parts; water, 1,500 parts. Boil the article in this mixture.

Electro Silver Plating.

Bisulphide of carbon in small proportions imparts a bright lustre to electro-plated articles. Put one ounce of bisulphide of carbon into a pint bottle containing a strong silver solution

DORFLINGER'S AMERICAN CUT GLASS.

The Finest Crystal, Plain and Cut, made in the World.



TRADE MARK.



TRADE MARK.

EVERYTHING that is used in Glass, for the Table.

Sells as well as Silver-ware.

EVERY FIRST-CLASS JEWELER

C. DORFLINGER & SONS,

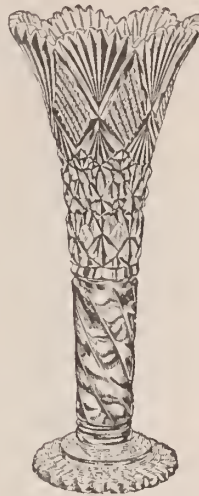

BEAUTIFUL, Artistic and Useful Pieces for Gifts.

Rivals the Diamond for Purity and Lustre.

SHOULD KEEP IT.

36 Murray Street, New York.

W. E. W. & CO.

Manufacturing Jewelers,



54 PAGE ST., PROVIDENCE, R. I.

OUR FINE Line of Gold Goods this season includes Bead Necks in ten and fourteen carat, Scarf Pins, Drops, Jersey Pins, Dress Sets, Rings and Bracelets, Band Bracelets in Plate, and the celebrated **POMHAM** Collar Button. To these has been added a full line of White Stone Goods in Gold for the Spring Trade. It should be remembered that **OUR GOLD BEAD NECKS ARE THE LIGHTEST MADE.** Ask to see them.

SELL TO JOBBERS ONLY.

W. E. WHITE & Co.

NEW YORK OFFICE, 26 MAIDEN LANE.

S. A. BALDWIN.

WILLIAM B. DURGIN

Designer and Maker of Wares in

STERLING · SILVER

SPECIALTY OF

Plain and Fancy Flatware

CONCORD, N. H.

CLASSIFIED INDEX TO ADVERTISEMENTS.

All Advertisements are entitled to one insertion under proper heading. Extra insertions, \$6.00 per Annum. Extra Headings \$12.00 per Annum.

	PAGE.
Assayers & Refiners.	
Lelong, L., & Bro., Newark, N. J.....	48
Howard, S. P., 8 John st., N. Y.....	48
Platt, Chas. S., 31 Gold st., N. Y.....	48
Robertson & Leber, 13 Franklin st., Newark, N. J.....	32
Auctioneer.	
French, J. H., Box 2775, N. Y.....	35
Black Onyx Jewelry.	
Woglom, Gilbert T., 32 John st., N. Y.....	40
Books, Stationery, etc.	
Dickie, W. B., 67 William st., N. Y.....	8
Cut Glass.	
Dorflinger, C. & Sons, 36 Murray st., N. Y.....	27
Mt. Washington Glass Co., New Bedford, Mass.	34
Diamond & Precious Stone Importers.	
Fera, Henry, 10 Maiden Lane, N. Y.....	32
Hedges Wm. S. & Co., 170 Broadway, N. Y....	39
Kahn, L. & M. & Co., 10 Maiden Lane, N. Y.	48
Kipling, E. E., 2 John st., N. Y.....	48
Kipling, R. A. 31 Union Square, N. Y.....	39
Lorsch, Albert & Co., 37 Maiden Lane, N. Y...	48
Oppenheimer Bros., & Veith, 35 Maiden Lane, N. Y.....	14
Peterson & Royce, 180 Broadway, N. Y.....	45
Randel, Baremore & Billings, 29 Maiden Lane, N. Y.....	33
Smith, Alfred H. & Co., 182 Broadway, N. Y....	24
Taylor & Bro., 860 Broadway, N. Y.....	4
Diamond Cutters.	
Groeneman, A. J. & Co., 80 Nassau st., N. Y...	40
Diamond Jewelry.	
Falkenau, Oppenheimer & Co., 40 Maiden Lane, N. Y.....	48
Ludwig, Nissen, & Co., 18 John st., N. Y.....	14
Stern Bros., 42 Maiden Lane, N. Y.....	39
Sexton Bros. & Washburn, 41 Maiden Lane, N. Y.....	11
Engravers and Designers.	
Bartholomew & Peckham, 18 Spruce st., N. Y.	40
Ryder & Dearth, 146 Wesminister st., Providence, R. I.....	14
Eye Glass Holders & Chains.	
Merritt, S. F., Springfield, Mass.....	38
Gas Engines.	
Schleicher, Schumm & Co., Philadelphia, Pa...	14
Gold Jewelry.	
Carter, Sloan & Co., 15 Maiden Lane, N. Y....	10
Cottle, S. Co., 860 Broadway, N. Y.....	48
Jonas, Dorst & Co., Race street, Cincinnati, O.	33
Krementsz & Co., 182 Broadway N. Y.....	31
Larter, Elcox & Co., 41 Maiden Lane, N. Y....	33
Moore & Horton, 11 Maiden Lane, N. Y.....	40
Owen, G. & S. & Co., 3 Maiden Lane, N. Y....	31
Riley, J. A., & Sloan Co., 860 Broadway, N. Y.	46
Street, Geo. O. & Sons, 15 John st., N. Y.....	46
White, W. E. & Co., 54 Page st., Providence, R. I.....	27

	PAGE.
Gold Chains.	
Rickert & Stiehle, Newark, N. J.....	8
Horological Schools.	
Elgin Horological School, Elgin, Ill.....	32
Waltham School of Horology, Waltham, Mass.	39
Jewelry and Silverware Cases.	
Schwarz, N., 866 Broadway, N.Y.....	40
Wiggers & Froelick, 60 Nassau st., N. Y.....	15
Jewelry Repairers.	
Thos. Juzek & Co., Elgin, Ill.....	32
Wiederhold, A., 20 Maiden Lane, N. Y.....	15
Jewelers' Offices.	
Jackson Building, Union Square, N. Y.....	42
Jobbers, Watches, Diamonds, etc.	
Aikin, Lambert & Co., 23 Maiden Lane, N.Y.	14
Beguelin, Tell A., 71 Nassau st., N. Y.....	15
Bowman & Musser, Lancaster, Pa.....	19
Conover, D. F. & Co., Philadelphia, Pa.....	5
Cross & Beguelin, 21 Maiden Lane, N. Y.....	16
Friedlander, R. & L., 65 Nassau st., N. Y.....	37
Hennege, Bates & Co., Baltimore, Md.....	36
Katlinsky & Gatzert, 96 State st., Chicago, Ill.	37
Koch & Dreyfus, 22 John st., N. Y.....	7
Myers, S. F. & Co., 48 Maiden Lane, N. Y.....	48
Scott, J. T. & Co., 4 Maiden Lane, N. Y.....	26
Yates, John B., 147 Nassau st., N. Y.....	19
Key Chains.	
Ingersoll, R. H., 65 Cortlandt st., N. Y.....	19
Musical Boxes.	
Jacot & Son, 298 Broadway, New York.....	40
Optical Goods.	
Geneva Optical Co., 23 Washington st., Chicago, Ill.....	14, 15, 19
Order Work.	
Maxheimer & Beresford, 3 Maiden Lane, N. Y.	46
Pens, Pencil Cases, Etc.	
Aikin, Lambert & Co., 23 Maiden Lane, N. Y.	14
Ring Makers.	
Bowden, J. B. & Co., 192 Broadway, N. Y.....	11
Bryant, M. B. & Co., 10 Maiden Lane, N. Y.	8
Odenheimer & Zimmern, 46 Maiden Lane, N.Y.	48
Haskell, H. C., 192 Broadway, N. Y.....	36
Hildreth Mfg. Co., 51 Maiden Lane, N. Y.....	32
Ostby & Barton, 80 Clifford st., Providence, R. I.....	14
Wodiska, Julius & Co., 49 Maiden Lane, N. Y.	39
Rolled Plate Chains.	
Cheever, J. G. & Co., No. Attleboro, Mass....	37
Kent & Stanley, 7 Eddy st., Providence, R. I....	3
Rolled Plate Jewelry.	
Foster & Bailey, 60 Richmond st., Providence, R. I.....	47
Ludwig, H. & Co., Providence, R. I.....	40
Plainville Stock Co., Plainville, Mass.	40
Seamless Wire.	
Burdon Seamless Filled Wire Co., Providence, R. I.....	38

	PAGE.
Settings & Galleries.	
Blancard & Co., 36 John st., N. Y.....	34
Silver Plated Ware.	
Pairpoint Mfg. Co., New Bedford, Mass.....	5
Rogers & Hamilton Co. The, Waterbury, Conn.	32
Rogers & Bro., 16 Cortlandt st., N. Y.....	7
Rogers, Wm., Mfg. Co., Hartford, Conn.....	15
Simpson, Hall, Miller & Co., Wallingford, Conn.....	9
Sterling Silver Jewelry.	
Blackinton, R. & Co., North Attleboro, Mass..	37
Sterling Silver Novelties.	
Alvin Mfg. Co., 860 Broadway N. Y.....	45
Lewis Bros., 41 Maiden Lane, N. Y.....	8
Sterling Silverware.	
Durgin, W. B., Concord, N. H.....	27
Gorham Mfg. Co., 19th st. & Broadway N. Y..	24
Ludwig, A. & Co., 247 Centre st., N. Y.....	16
Towle Mfg. Co., Newburyport, Mass.....	35
Wallace, R. & Sons, Mfg. Co., 3 Park Place, N. Y.....	6
Wood & Hughes, 16 John st., N. Y.....	8
Tool Manufacturers.	
American Watch Tool Co., Waltham, Mass....	40
Bullock, O. W. & Co., Springfield, Mass.....	39
Chicago Watch Tool Co., Chicago, Ill.....	14
Watch Companies.	
Non-Magnetic Watch Co., 177 Broadway, N. Y.	11
Start.....	39
Trenton Watch Co., Trenton, N. J.....	13
Watch & Clock Oils	
Nye, William F., New Bedford, Mass.....	14
Watch Keys.	
Clark, A. N., Plainville, Conn.....	4
Kendrick & Davis, Lebanon, N. H.....	34
Watch Case Manufacturers.	
Brooklyn Watch Case Co., 192 Broadway, N.Y.	31
Courvoisier, Wilcox Mfg. Co.....	12
Essex Watch Case Co., Newark, N. J.....	34
Feinier, G. F., 9 Bond st., N. Y.....	40
Muh's Sons, H., 629 Chestnut st., Philadelphia, Pa.....	17
Roy Watch Case Co., 17 Maiden Lane, N. Y.	48
Watch Importers.	
Witnauer, A., 30 Maiden Lane, N. Y.....	8
Watch Materials, &c.	
Cross & Beguelin, 21 Maiden Lane, N. Y.....	21
Friedlander, R. & L., 65 Nassau st., N. Y.....	37
Keller, L. H. & Co., 64 Nassau st., N. Y.....	15
Watch Repairers.	
Simmonds, J. C., 18 John st., N. Y.....	15

Special Notices.

Rates 75c. per insertion for notices, not exceeding 3 lines; additional words 2 cents each. If answers are to be forwarded, postage stamps must be enclosed. Two insertions, 10 per cent. off; three insertions, 15 per cent. off; four insertions, 25 per cent. off. Payable strictly in advance.

Situations Wanted.

THE JEWELERS' CIRCULAR has a guaranteed circulation of over 10,000 copies weekly. It is, therefore, the best medium for reaching the trade. To demonstrate this to advertisers, notices in this column will be inserted free of charge during the month of March.

A RETAIL JEWELER of experience desires a position as traveling salesman. Best of reference or bond, if necessary, to responsible house. Address, Lock box 16, Boyden, Iowa.

ACCOUNTANT, partially disengaged, would write up, examine or keep a set of books. Highest reference; terms moderate. Address, Expert, P. O. Box 2456, New York.

A POSITION wanted under a first-class workman, to finish trade. Have had 2½ years' experience, and some knowledge of optical goods; can furnish a reference. Address, Box 57, Alfred Centre, N. Y.

A NICKEL PLATER desires a situation; thoroughly understands the business; can give best of reference if required. Address, Plater B, this office.

POSITION WANTED by an experienced and A1 traveling salesman; good references given. Address H. F., care THE JEWELERS' CIRCULAR.

WANTED.—Situation by a watchmaker of 15 years' experience; full set of tools and best references furnished; North or West preferred. Address, C. A. S. Edgett, 45 East Mitchell street, Atlanta, Ga.

WANTED.—Position by young man; with five years' experience in watch, clock and jewelry repairing; A1 references. Address, Watchmaker, Box 102, Charles City, Iowa.

WANTED.—We have in our employ a young man about 24 years old who has been with us about 4 years, excellent habits, a good salesman, watchmaker general repairer and plain letter engraver; he is worth more than we can afford to pay and would like to get him a good position at about \$15 per week. Address, Lock Box 944, Lyons, Wayne Co., N. Y.

WANTED.—Position by a first class watchmaker, clockmaker, jeweler, and repairer of musical toys, etc. Can put my hands to any variety of repairing work. Have had thirty years' experience; can furnish best of references and security if desired. Would prefer a position in New York City or near-by town. Address, D. H. J., care THE JEWELERS' CIRCULAR.

WANTED.—A married man about 38 years, with 18 years' experience, at the bench, would like position with first-class house; wages \$18 per week. Am strictly temperate and honest; best of references, have my own tools. Address Epworth, care JEWELERS' CIRCULAR.

WANTED.—Situation as traveling salesman with reliable manufacturing or jobbing firm. Will carry any line connected with the jewelry business. Good reference; no bad habits, and a hard worker. Seventeen years in the retail business. Address, C. L. James, 17 14th street, Toledo, O.

WANTED.—By a young man of 23, position as assistant watchmaker under finished workman, where I can be instructed on difficult and complicated work. Have had between 2 and 3 years' experience; am strictly temperate, and can give best of reference. Address "L," 224 Main street, Middletown, Conn.

WANTED.—By a single man, 26 years of age, a position in a wholesale jewelry or diamond importing house, as salesman in office or to travel. Have had five years' experience in a retail jewelry store. Highest references given. Address, V. Z., care JEWELERS' CIRCULAR.

YOUNG MAN with six years' experience, who understands watch and clock work, when not complicated, would like a position with a first-class watchmaker, to finish learning the trade. Is temperate, honest and industrious, and has all necessary tools except American lathe. Best reference; moderate salary expected at first. Address Jas. H. Gruhh, Clearville, Pa.

YOUNG MAN who understands hard soldering and can do clock-work and watch-work when not complicated, would like to get a position with a first class watchmaker and finish trade. Temperate, honest, industrious and does not use tobacco. Expects a reasonable salary to commence. Have good mechanical ideas. Some tools. Address, F. E. Hackett, Box 476, Baton Rouge, La.,

Help Wanted

A YOUNG MAN familiar with silver plated ware, full of push as junior salesman. Address with full particulars giving experience. References, salary expected, etc., Address B. R., Box 320, N. Y. P. O.

WANTED.—A first class traveler. One acquainted with Texas trade preferred; good salary. Address, Koch & Dreyfus, 22 John street, New York.

WANTED.—A thoroughly competent watchmaker and jewelry repairer in New England city; must have tools and experience, and be well recommended; state age, experience, and salary desired. Address Good Opportunity, care JEWELERS' CIRCULAR.

WANTED.—A few traveling men who are practical watchmakers, and have the time to call the attention of the craft to the Mosely Lathe and Attachments, through the East and Southwest. Address, Mosely & Co., Elgin, Ill.

For Sale.

A FINE ship chronometer for sale cheap. Address: A. C. Taylor, Cedar Rapids, Iowa.

FOR SALE. 1½ Whitcomb Lathe, Wehster wheel, universal head slide rest, Beach & Snyder chuck, and a full line of split wire chucks, counter shaft, etc. Will be sold cheap. Address, B. H. Cosby, Asheville, N. C.

FOR SALE.—A Mosely No. 1, soft lathe with ten chucks, countershaft, footwhale and universal face plate all nearly new. Also one standard lathe cheap. Wanted to buy, or will trade the above for a No. 3, hard American lathe or a watch factory machinist's bench lathe. Address Box 1407, Rockford, Ill.

FOR SALE at a sacrifice. A well established jewelry business in the northern part of the State. Cash receipts 1890, \$12,000. Stock will inventory about \$6,000, but can be reduced. Address, Lock Box 2, Port Henry, N. Y.

WILL sell or exchange for goods, a large Herring jewelry safe; also a large Terwilliger jewelry safe for sale or exchange. Address, T. B. Bynner, 177 Broadway, New York.

To Let.

TO MANUFACTURING JEWELERS AND OTHERS. A floor to let in the new improved factory building, corner St. Marks and Underhill avenues, Brooklyn. Fine light, power and all modern improvements; within twenty minutes of the Brooklyn ferries. Apply to Geo. W. Shiebler, 8 Liberty Place, New York City.

TO LET.—First floor back, No. 18 John street, 3 windows; possession at once if desired. Apply to Chas. Magnus.

Business Opportunities.

FOR SALE.—In one of the most rapidly growing manufacturing towns in Pennsylvania. Five new stock of watches, clocks, jewelry material and fixtures. Trade well established and growing, plenty of bench work. Low rent. Practically no opposition. Will invoice about \$6,500. Stock can be reduced, good reasons for selling. Address, Pennsylvania, care THE JEWELERS' CIRCULAR.

SPECIMEN of "Native Wire Silver," just as taken from the mine, mounted in a scarf pin. Remarkable curiosity; very rare; only a limited number; single one \$1.50; four for \$5.00. Address, Charles F. Easton, Marysville, Mont.

Miscellaneous.

JEWELERS wishing to become thorough opticians, should send for particulars in reference to my course of mail instructions. Address, Dr. H. L. King, Helena, Mont.

W. A. SCHROETER, 198 Grand street, New York City. Estimates rendered on any desired job. Four expert watch repairers employed specially for Trade Work. Guaranteed finely finished at low prices. Also a good chance for a young man to study watchmaking.

W. F. A. WOODCOCK'S SCHOOL FOR WATCHMAKERS, Winona, Minn., offers unrivaled facilities for acquiring a thorough practical knowledge of every branch of the business. Terms very reasonable.

LOOK OUT

FOR

BIRTHDAY RINGS,

IN

HANDSOME

NOVEL WINDOW TRAY,

(Patented.)

— I I —

M. B. BRYANT & CO.,

10 Maiden Lane, New York.

Recent Patents

Issue of February 17, 1891.

THE MODEL NO. 19,023 OPERA, MARINE AND FIELD GLASSES AND LENSES. D. C. PIERCE & CO., Boston, Mass. Application filed January 11, 1890. Used since January 17, 1890. "The words 'Le Meris'."

THE MODEL NO. 19,041 WATCH MOVEMENTS AND CASES. BY L. S. KRASNER & CO., New York, N. Y. Application filed January 20, 1890. Used since April 15, 1890. "The letters and word 'P. H. Dorci' and the representation of a Maltese cross."

THE MODEL NO. 19,045 WATCH MOVEMENTS AND CASES. BY L. S. KRASNER & CO., New York, N. Y. Application filed January 20, 1890. Used since April 15, 1890. "The words and letter 'R. Lanier, Geneva,' and the representation of an arrow."

THE MODEL NO. 19,016 WATCH CASES AND MOVEMENTS. BY L. S. KRASNER & CO., New York, N. Y. Application filed January 20, 1890. Used since July, 1888. "The words 'Atleboro Watch Company.'"

THE MODEL NO. 19,017 WATCH CASES AND MOVEMENTS. BY L. S. KRASNER & CO., New York, N. Y. Application filed January 20, 1890. Used since July, 1888. "The words 'Hartford Watch Co.'"

116,611. OPERA GLASSES. CHARLES A. PIERCE and WILLIAM H. H. NORTON, Boston, Mass., assignors to George H. Eaton & Co., same place. Filed May 15, 1890. Serial No. 351,088. (No model.)

Claim. Opera-glasses having lens-holding plates and a connecting medium for such plates, one of such lens-holding plates having a socket to receive the connecting medium, which socket is provided with a shouldered notch, combined with a spring-latch on the connecting medium adapted to be engaged with and disengaged from the said shouldered notch, substantially as described.

116,618. SEAMLESS COMPOUND GOLD AND SILVER WIRE. LEVI L. BURDON, Providence, R. I., assignor to the Burdon Seamless Filled Wire Company, same place. Filed July 22, 1890. Serial No. 350,479. (No specimens.)

Claim.—As an improved article of manufacture, a compound wire consisting of a seamless exterior surface of fine metal, as gold, and an interior portion of silver, united to said exterior portion.

116,619. MANNER OF PRODUCING SEAMLESS COMPOUND WIRE. LEVI L. BURDON, Providence, R. I., assignor to the Burdon Seamless Filled Wire Company, same place. Filed July 22, 1890. Serial No. 350,273. (No model.)

Claim.—The improvement hereinbefore described in the manufacture of seamless compound wire, the same consisting in first producing a seamless exterior shell of alloyed fine metal, or even a seamless compound tube; next introducing a suitable metallic core into said shell, then uniting the core and shell, thereby forming the ingot; next repeatedly subjecting the suitably-prepared ingot to a squeezing or swaging operation, which acts to gradually and uniformly reduce it from circumference to center and at the same time elongating it, and finally subjecting the reduced ingot to drawing mechanism which acts to still further elongate it and gives to the seamless wire thus produced the desired form and size cross-sectionally.

116,681. ELECTRIC MUSIC BOX. CHARLES A. HARRIS, New York, N. Y., assignor to M. J. Paillet & Co., same place. Filed Dec. 20, 1890. Renewed Nov. 1, 1890. Serial No. 370,000. (No model.)

Claim.—The combination, with a comb and pin-cylinder, of gearing for rotating said pin-cylinder, a worm connected with said gearing, an armature detachably connected with said worm, and field-magnets between which said armature can rotate, substantially as set forth.

116,737. WATCH-CASE. EDWARD F. HEEFER, Toronto, Ontario, Canada. Filed Apr. 19, 1889. Serial No. 377,340. (No model.)

Claim. In a watch-case having its back or bezel screwed to the center by means of a screwed joint, a rim connected to the back or bezel and having a thread cut on it to correspond with and form a continuation of the thread which forms a screw-joint, in combination with a hinge designed to connect the screwed ring with the center, substantially as and for the purpose specified.

116,801. ELECTRIC REGULATING-CLOCK. DÉJARDIN VAN DE PLANCKE and GUSTAVE VAN DE PLANCKE, Conrai, Belgium. Filed May 21, 1886. Serial No. 341,580. (No model.) Patented in Belgium Feb. 4, 1885, No. 67,750; in Germany Apr. 13, 1885, No. 34,044; in France June 29, 1885, No. 169,834, and in England July 14, 1885, No. 8,538.

Claim. In an electric clock, the combination of an electro-magnet with an electric circuit adapted to excite the said magnet at regular intervals of time, an unequally-weighted fly-wheel mounted on a horizontal axle and adapted to act on the clock mechanism, a striking-lever connected with the armature of the electro-magnet and adapted to give to the fly-wheel at every attraction of the armature an impulse sufficient for an entire revolution, a brake device adapted to consume any excess of energy of the fly-wheel, and a check-lever or detent adapted to prevent the fly-wheel from turning back, substantially as described, and for the purpose specified.

An Auction Case in Court.

WATERBURY jewelers have been much interested over the trial of Frank G. Cummings, who has charge of the Waterbury store of A. D. White, of New Haven. He was tried on the charge of obtaining money under false pretences. The complainant, R. B. Foley, bought a watch for \$21 at auction of Cummings who was auctioneer. A printed guarantee from A. D. White that the cases are solid gold was pasted inside, and the purchaser had a verbal agreement with the auctioneer that his money would be refunded if the cases were not solid gold. He was dissatisfied and had the cases tested. He returned for his money, but the auctioneer refused to give it up. H. G. Chatfeld another Waterbury jeweler, testified that the watch was simply gold plate over brass. Frank W. Upson, of the Upson Jewellery Co., and Chris. Strobel, of Lake, Strobel & Co., both testified that they had examined the watch and agreed with Mr. Chatfeld. The State rested here. For the defense, Mr. Cummings testified that he sold the watches on the guarantee of the manufacturers and on the instructions of his employer, Mr. White, of New Haven, and maintained that the tests of his Waterbury jewelry competitors, were not fair. Henry Frank, watchmaker and clerk in White's New Haven store, testified that he had been a jeweler twenty-three years, worked for White a year, and that he thought the cases would pass for "low karat" gold and that the tests were not fair. The lawyer now summed up, Lawyer Root for the defense claiming no criminal intent and that the prosecution was based on jealousy of

competitors, etc.; while the prosecuting attorney held that there was manifest fraud; that all the reputable jewelers in town had found the cases bogus or plated and that local merchants should be protected from red flag itinerant auctioneer merchants who promise everything and then move on. Judge Connell reserved his decision.

Protected by Electricity.

PROVIDENCE, Feb. 21, 1891.—Apropos to the convention of the National Electric Light Association, which has been held in this city this week, a few words relative to the number of manufacturing jewelers who enjoy the advantages and increased security by the protection offered by the Rhode Island Electric Protective Company, of which Isaac M. Potter, of Potter & Buffinton and William Smith, Jr., of William Smith & Co., were two of the original incorporators three years ago when this concern succeeded the Providence branch of the Holmes Burglar Alarm Telegraph Company.

The following manufacturing jewelers are protected by this company's system. Potter & Buffinton, Dutec Wilcox & Co., G. & S. Owen & Co., Martin, Copeland & Co., Thomas Quayle & Co., William M. Fisher & Co., Charles Sydney Smith, Joshua Gray, A. T. Wall & Co., William Smith & Co., Waite, Thrasher & Co., George H. Taylor & Co., James A. Foster & Co., Arnold & Steere, William C. Greene & Co., Hutchison & Heustis, Ostby & Barton, Farrington & Co., Leeder & Bernkopf, Harvey & Otis, Payton & Kelley, S. B. Champlin & Son, Charles F. Irons, Brown & Dorchester, R. L. Moorhead & Co., Horace Remington & Son, Albert Lorsch & Co., John Austin & Son, Henry C. Whittier, Herbert S. Tanner, Tilden, Thurber & Co., Albert Walker, Kirby, Mowry & Co., S. & B. Lederer, William Loeb & Co., The Howard & Son Co., D. C. & H. S. Fink, Sterns Hutchins, Wood, Bicknell & Potter, Otis Bros., W. E. Webster & Co., J. B. & S. M. Knowles, Hancock, Becker & Co., B. A. Ballou & Co., Hamilton & Hamilton Jr.

The Dueber Matter.

Late advices from Canton, Ohio, say that nothing new has developed regarding the Dueber failure, excepting that on Feb. 16 200 more hands were put on at the Hampden works.

Saturday night the foreman at the Hampden works gave a banquet to Superintendent John C. Coburn, at which John C. Dueber was the honored guest.

Elmira.

Frevilnheim & Abramson, the Lake street jobbers, have established a branch house at 40 Maiden Lane, New York. Mr. Abramson went to New York this week to take charge the metropolis.

The extensive retail business of the late E. H. Hyrer is being continued by his brother and father.

TRADE GOSSIP

Among the handsomest settings the trade has perhaps seen is the "S," a novelty in marquise rings, manufactured and controlled by Stern Bros., 42 Maiden Lane. Though just placed upon the market, the trade have taken hold of it with much favor. It is made in 14 K. and 18 K. gold, and is adapted to being set with a variety of precious stones. Considering the excellence of the design and workmanship, the price asked is very low. The manufacturers will furnish samples on application. An illustration of this attractive article appears on another page.

Geo. W. Shiebler, 6 Liberty Place, New York, is satisfying the present fad for souvenir spoons with most beautiful designs. On orders for Hartford, Conn., he supplies exquisite little spoons; the bowl represents a full-grown nutmeg, and the handle the flower and and leaves; for Boston, the bowl with an etching of the historical "Tea Party or of a "Hub;" for Baltimore, the bowl displaying an etching of the Monument; Washington, the Capitol; New York, the Brooklyn Bridge; Cedar Rapids, Quaker Oats, and so on. The demand for these goods helps to keep the Shiebler's spacious factory very busy. The inspector of this manufacturer's line is constantly surprised at the exquisite beauty and excellence of design and workmanship of each individual taste. Mr. Shiebler's constant endeavor is to produce something original; that he succeeds is evidenced by the heavy sales of some of his patterns, such as the "Flora," the sale of which many dealers say is unprecedented in its line. When types or models are followed, he endeavors to go other manufacturers one better. His line comprises everything made in silver from a soup tureen to a book-mark. Speaking of book-marks, Mr. Shiebler has produced many beautiful patterns in a new style of construction which holds the back instead of the side of the book, and proves an ornament as well as a thing of usefulness.

The Trenton Watch Co. are very well satisfied with the success which their new movements have met in their reception by the trade, and already they are full of orders. These new movements are 18 size, seven jewel stem wind and possess several many desirable features, which will be appreciated by dealers. They are excellent time-keepers and the price is so low that there is certainly a larger field for such a watch; and the Trenton feel it alternately.

The silver and gold plated ware, exhibited at the Jamaica exposition, by the Pairpoint Manufacturing Company, of New Bedford, astonishes sightseers, and the expressions of admiration that fall from the lips of some of the dusky maids and matrons are exceedingly amusing.

KREMENTZ & Co.,

182 & 184 Broadway, NEW YORK,

MANUFACTURERS OF

GOLD JEWELRY,

14-K. BEAD NECKLACES,

— AND —

KREMENTZ ONE-PIECE COLLAR BUTTONS.

ESTABLISHED 1834.

G. & S. OWEN & CO.

MAKERS OF

— FINE JEWELRY, —

Lace Pins, Ear Rings, Scarf Pins, Sleeve Buttons, Sash Pins, Collar Buttons, Bracelets, Studs.

All Goods sold by us are exclusively of our own manufacture and are warranted 14 K. Fine, and stamped as such when possible.

No. 3 MAIDEN LANE, NEW YORK.

The Patent O. F. Cases have these Advantages over the Regular Case: They are Dust Proof and Decidedly Cheaper.

EXAMINE THIS

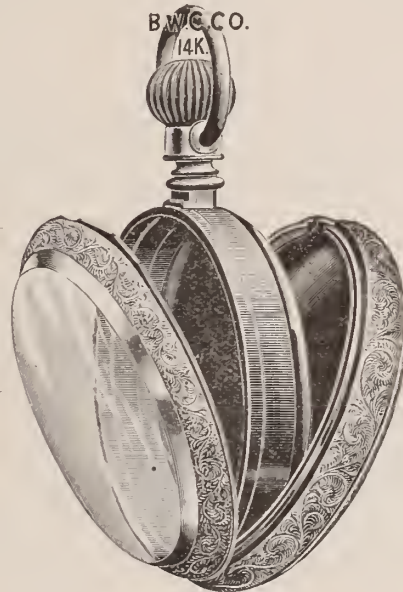

NOVELTY IN 14-K.

O. F. DUST BAND.

THE BROOKLYN WATCH CASE CO.

192 Broadway, New York,

HAVE IN STOCK AND FOR SALE BY ALL JOBBERS

❖ 14-K. Brooklyn Eagle Wheat and Granger ❖

GOLD CASES IN 18, 16, 6, 14 AND 0 SIZES ADAPTED TO ALL MOVEMENTS OF THE ELGIN MODEL.

The Roy Watch Case Co., 17 Maiden Lane, New York, are showing some remarkably handsome decorated gold cases, quite equal to anything seen in imported goods.

O. W. Bullock & Co., Springfield, Mass., are having great success with their new "Victor" screwdriver, made in six sizes, distinguishable by different colored heads. The standard ring gauge of their manufacture has taken its place among the staples in the line of materials, as all the goods of this firm do.

At the Waltham Horological Institute, Waltham, Mass., preparations are being made to turn out the "Palmer" watch in much larger quantities than heretofore. This watch, which ranks high among fine timepieces, is the invention (in many of its details) of D. D. Palmer, the ingenious proprietor of the school.

In one of the show windows of Thomas Evans & Son's jewelry store, on Columbia street, Utica, N. Y., is displayed an interesting collection of old coins. The collection is a valuable one, and embraces pieces from nearly every civilized country. There are several thousands of them, and they are daily inspected by many who have an eye for the curious.

M. B. Bryant & Co., the wide awake ring makers, 10 Maiden Lane, New York, wish it to be understood by the trade that while they are pushing the well known "Bryant" initial ring in a manner consistent with its

TO THE TRADE ONLY.

Balance Staffs, - 60 Cents.
Inserting Pivots, 40 Cents.

ALL OTHER WORK IN PROPORTION.

SEND FOR PRICE LIST.

THOMAS JUZEK & CO.,
ELGIN, ILL.

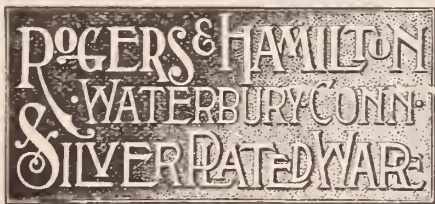

merits and the growing demand for it, they are not slighting their line of fancy store rings, new patterns by the score being shown in verification.

Col. Jesse M. Rutherford, the well known Jewelers' auctioneer, of this city, has a valued memento of the recent sale for Penrose Myers, Gettysburg, Pa. It is a hickory cane cut from Little Round Top, an historic spot in the great battlefield, where General Strong Vincent fell. On the head are etched in India ink the colonel's likeness, the Reynolds monument and Meade's headquarters. The colonel prizes it highly.

Since the recent change of the well known firm of Howard & Son, to a corporation, The Howard & Son Co., the designers of the company have been hard at work on a brand new line of goods for the spring season. Not that new goods have been any rarity with Howard & Son, but in commemoration of the change they have put forth extraordinary exertions to give the new company an introduction to the trade in keeping with the record of the firm it succeeded. In this they have not been disappointed if the bustle in their factory is a fair criterion.

ANNOUNCEMENT.

NEW YORK, FEBRUARY 16th, 1891.

DEAR SIR:

WE, THE UNDERSIGNED, HAVE THIS DAY FORMED A CO-PARTNERSHIP UNDER THE FIRM NAME OF MARSELLUS & PITT, TO CARRY ON THE BUSINESS OF IMPORTING AND DEALING IN PRECIOUS STONES AND PEARLS, AT 18 JOHN STREET, NEW YORK, N. Y.

RESPECTFULLY SOLICITING YOUR TRADE, WE ARE,

YOURS VERY TRULY,

M. de M. MARSELLUS.

ALFRED S. PITT.

ROBERTSON & LEBER,

GOLD, SILVER AND

PLATINUM

REFINING.

PLATINUM SCRAPS MELTED

13 & 15 Franklin Street, Newark, N. J.

JEWELERS' SWEEPINGS A SPECIALTY.

PLATINUM FOR SALE.

HENRY FERA,

IMPORTER OF DIAMONDS,

AND DIAMOND BORTZ,

Diamond Cutting and Polishing Establishment,

10 Maiden Lane, NEW YORK.

ELGIN HOROLOGICAL SCHOOL

ELGIN, ILL.

SEND FOR CIRCULAR.

Repairing for the trade.

Repair price list free.

◆ HILDRETH MANUFACTURING COMPANY, ◆

53 MAIDEN LANE, N. Y.

◆ PLAIN GOLD RINGS. ◆

QUALITY GUARANTEED.

LOWEST PRICES.



SEND FOR PRICE LIST.



To Whiten Iron.—To render iron as white and beautiful as silver take ammoniacal salt in powder and mix it with an equal quantity of quicksilver, dissolve in cold water and mix well. When done immerse the red-heated metal in this bath and it will become as white as silver. Be careful not to burn the article by over-heating.

Clock Repairing.—One of our methods in trying to get the clock to be a uniform time keeper is to change the mainspring for one well finished and not quite so strong as the original one. Perhaps someone will say, "why not do this before we go to the trouble of flattening the bottom pivot?" Just this; when a pivot is working only upon the bottom it is best to have a flat surface to work upon, as the balance is then oscillated with more uniformity, even when the mainspring is not exactly uniform in its pressure. Therefore we do no harm—but good—by making the bottom pivot flat, and this alone will sometimes be sufficient to cure the fault of the banking, if nothing else.

Tinkering With Rollers.—Rollers are usually made true and round, and, if not so, the trouble is generally the result of some unskilful workman's tinkering. If the roller seems out of shape because the balance-staff has been pivoted, and the pivot does not correspond to the center of the staff, do not spoil the roller to correct another fault; repivot the staff or put in a new one. But if the roller has been filed off on one side to allow the guard-pin freedom so that the roller runs comparatively true on the untrue staff, correct your pivot all the same, and then correct the roller. If the watch is a fine one put on a new roller; otherwise use the old one, if not too badly injured. The tinkered roller after being filed on one side, seems out of shape; and so it is, and must be corrected.

Bouchons. The tapped bouchon, says Cl. Saunier, is very firm, but in order that it may be well centered it is essential that its thread fit exactly the tube of the tool. When brushing holes that are rather large, with solid bouchons, after the hole has been marked with the pointer it must be drilled with a small drill, a large one being subsequently passed through so as to increase it; otherwise, there is great danger of the hole turning to one side. If a hole such as that of the centre wheel is brushed with a perforated bouchon, it will often be found to incline toward the barrel or fuzee, so that the hole is displaced. Such an inconvenience may be avoided by using a bouchon with a hole smaller than is ultimately required, afterward enlarging it with the plate centered (by the bar pivot hole) in the mandril or lathe.

ESTABLISHED 50 YEARS.

RANDEL, BAREMORE & BILLINGS,

IMPORTERS OF

DIAMONDS,

AND OTHER PRECIOUS STONES.

FINE PEARLS A SPECIALTY.

MANUFACTURERS OF

DIAMOND JEWELRY,

IN THE LATEST DESIGNS.

Diamonds Recut in Modern Styles or Repaired on Premises.

58 Nassau Street,
29 Maiden Lane,
NEW YORK.

1 Tulp Straat,
AMSTERDAM.

1 St. Andrews St.,
Holborn Circus,
LONDON, E. C.

LARTER, ELCOX & CO.

MANUFACTURERS OF

THE SPRING BACK STUD.

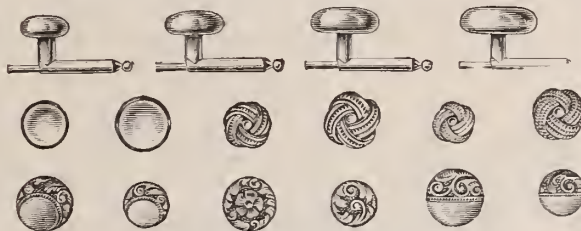

Send for Selection Package of Studs.

—
SNAKE RINGS.

—
GENTLEMEN'S
WHITE ONYX JEWELRY.

—
LADIES' RINGS.

—
Gentlemen's Rings.

FACTORY, NEWARK, N. J. + + OFFICE, 41 & 43 MAIDEN LANE, N. Y.

JOSEPH JONAS.

JACOB DORST.

JONAS, DORST & CO.,

Manufacturing Jewelers and Importers of Diamonds.
169, 171 RACE STREET,
CINCINNATI, OHIO.

WE MAKE A SPECIALTY OF ALL STYLES OF

✂ DIAMOND MOUNTINGS. ✂

Society and School Badges,

FANCY MONOGRAMS and RINGS of all Descriptions.

We are prepared and have complete facilities for doing REPAIR WORK with neatness and dispatch.

DESIGNS EXECUTED FOR SPECIAL WORK

We are the exclusive manufacturers of the celebrated Ophir Diamond Goods.



KENDRICK & DAVIS,

LEBANON, N. H.

MANUFACTURERS OF THE



Standard Dust Proof Watch Key.

After this date all Keys of this Style will have number stamped on each Key.

FOR SALE BY THE TRADE.

DIAMOND SETTINGS. GALLERIES. HOLLOW BALLS, ETC.

BLANCARD & CO.,

36 & 38 JOHN STREET,

SEND FOR OUR NEW YORK. CATALOGUE.

Essex Watch Case

COMPANY,

T. B. HAGSTOZ, President.

TRADE MARK



6 Maiden Lane, N. Y.

NEWARK, N. J.

GOLD FILLED CASES.

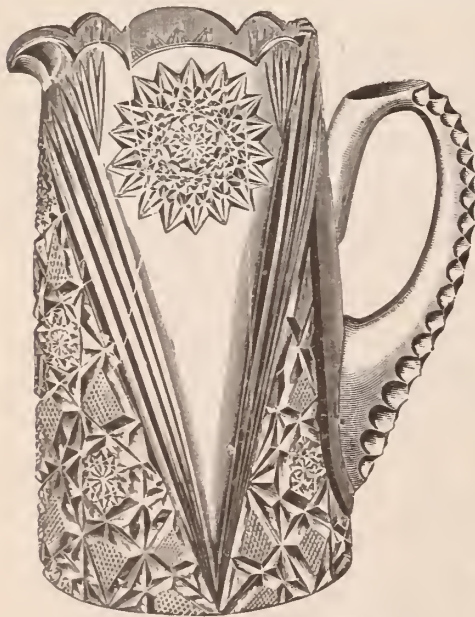

The Latest "TURKIAN" Design.

RICH CUT GLASSWARE.



Headquarters in America for
ART GLASSWARES,
RICH CUT AND DECORATED.
Lamps, Vases and complete lines of everything for
table use or household decoration.

MT. WASHINGTON GLASS CO.

NEW BEDFORD, MASS.

CATALOGUES FOR

NEW YORK OFFICE, 46 MURRAY STREET. INTENDING PURCHASERS.

Growth of the Jewelry Trade.

With Special Reference to Some Providence, R. I., Houses.

THE wonderful and rapid growth of the jewelry business is made plainly apparent by the following statistics, covering a period of about six and a half years. The statistics were compiled by the Jewelers' Mercantile Agency. The number of jewelers in the entire country on January 1, 1890, was 21,098. They were distributed among 7,067 towns and cities and were classified as follows: Manufacturers, 1,433; wholesale jewelers, 828; wholesale dealers (not jewelers), 200; retail jewelers, 13,895; retail dealers (not jewelers), 1,166; repairers only, 3,457; peddlers, 119; total, 21,098. The following table gives the comparison between the number of towns containing jewelers and also the number of jewelers in the whole country from July, 1883 to January, 1886, and also from the latter date to January, 1890:

	No. of Towns.	No. of Jewelers.
July, 1883	4,722	14,101
Jan'y 1886.....	5,663	17,861
Increase in 2½ years.....	941	3,760
Per cent. of increase in 2½ years	19.93	26.66
Jan'y, 1890.....	7,067	21,098
Increase in 4 years.....	1,404	3,237
Per cent. of increase in 4 years..	24.79	18.12
Increase in 6½ years.....	2,435	6,997
Per cent. of increase in 6½ years	40.66	49.62

Thus it is shown that in six and one-half years jewelry towns have increased nearly fifty per cent. It also goes to show that the means for the distribution of jewelry have more than balanced the improved methods of manufacture. The growth of the industry in Providence is hardly less phenomenal.

Seril Dodge was the earliest jewelry manufacturer of whom we have any record in this vicinity. We are told that he had an establishment for the making of the shoe buckles worn by the dandies of that day. The name of Dodge has been more or less prominent in the business from that time to the present. To Nehemiah Dodge, however, a few years later, may be attributed the credit of really founding the jewelry industry in Providence. It was in 1794 that he established himself as a "goldsmith and jeweler, clock and watchmaker" in a little shop on the Roger Williams' estate, North Main street. Heretofore gold jewelry was made eighteen carats fine, and being all wrought by hand was very expensive. Knowing that trade would be greatly improved if the price of the manufactured article was reduced, he conceived the idea of introducing a cheaper class of work. Of exactly what this cheaper jewelry consisted there is no record, and our older jewelers do not seem to have a very clear idea. It is highly probable, however, that it was the system of washing or gilding which preceded the modern electro-gilding.

Mr. Dodge at once won success, and the industry began its growth, advancing so rapidly that in 1810 we find that about 100 workmen were employed in the manufacture of about \$100,000 worth of goods yearly. In 1812 there were about 175 workmen em-

ployed, and the value of products during the year was \$300,000. The "last war with England" paralyzed the industry, but upon the declaration of peace, the jewelers took up the business where they had left it off, and in 1820 there were 300 workmen employed, and the product was valued at \$600,000.

From 1825 to 1857, the year of the great financial crisis, the jewelry industry grew and prospered. In 1850 the business had grown to forty-five or fifty shops, in which were employed about 1,200 men and boys. Just before the panic of '57 there were fifty-six shops; in 1860 there were seventy-seven, according to the United States census and eighty-six, by the Providence directory, representing a capital of more than a million of dollars. The war period came on and caused radical changes. The demand for jewelry fell off materially and, as a result, in 1864 the eighty-six firms had dwindled to fifty-six. The period of inflation and high wages subsequent to the war was a good time for the jewelers, and the number of firms again increased, so that in 1870 there were seventy-nine shops; in 1875, 133 shops, employing 2,667 persons; in 1880, 142 shops, employing 3,264 persons. At the present time there are 235 shops, employing upward of 10,000 person and having an estimated capital invested of \$4,293,258.

When about 1880 the separable buttons made their appearance in the market, they were thought to be the perfection of the jewelers' art in the direction of doing away with the annoyance inseparable from using the old style of one piece button in a stiff cuff or collar. The firm of Fred J. Marcy & Co., however, realizing not only that the separable buttons often cause procrastination instead of economy of time by reason of their parts becoming lost, but that a man nervous from haste in dressing is often sorely put to in joining the parts, undertook to produce a button that would facilitate dressing and thus become a boon to the hurried business men of these days. This they succeeded in doing by simply connecting the shoe of the button to the post with a lever, thus allowing it to assume the line of the post and be easily thrust into the button hole and quickly secured. The button was patented August 24th, 1881, and at once put upon the market. It was one of the first lever buttons produced. It received instant recognition and commanded large prices, and that its popularity has always been retained is fully attested by the ever-increasing demand. At present they make more than 6,000 different styles, which are sent throughout the United States, Canada, Mexico, South America, Europe and Australia.

GADSDEN, Ala., Feb. 12, 1891.

I congratulate you upon the very agreeable change from a monthly to a weekly, and wish you great success in your enterprise.

R. O. RANDALL.

LYONS, N. Y., February 9, 1891.

We think you did a grand thing to publish weekly instead of monthly.

HOFFMAN & ROBINSON.

TOWLE MFG. CO.,

MANUFACTURERS OF



Sterling Silverware



NEWBURYPORT, MASS.: 214 MERRIMACK ST.

CHICAGO:

149 & 151 STATE ST.

SAN FRANCISCO:

220 SUTTER ST.

ESTABLISHED 1873.



If for any reason you should desire the services of an AUCTIONEER, and will write me as to the amount of stock you have on hand and its general character, the size of your store and the number of inhabitants of your town or city, I could, from my extended experience, give you an idea of the amount of business you could expect under the circumstances, and, no doubt, be able to refer you to some one for whom I have sold under conditions similar to your own.

As a general reference, you could hardly find a wholesale jeweler who is not familiar with some of the numerous successful sales I have made.

I have made many successful AUCTION SALES, and have yet to record a failure to fully satisfy the owners. Can give you hundreds of references to that effect.

If the business should be urgent and I am myself engaged, I have two competent assistants instructed in my methods whom I could send on short notice.

Any correspondence with me will be strictly confidential in every case.
P. O. Box 2775.

NEW YORK CITY.

ONE OF THE OLDEST RESTAURANTS
DOWN TOWN.



POPULAR PRICES

Eastern Jewelers Interested.

The Taber Bros'. Manufacturing Company of Dallas, Texas, who made an assignment a few weeks ago, are making a conditional compromise offer of 33 1/3 cents on the dollar to all who will accept. This offer it is stated, however, will not be accepted by the Providence creditors. Mr. J. Taber was expected to be in New York city last week to meet a committee of the eastern creditors, but he failed to put in an appearance.

The total liabilities are \$30,594.31. The total assets about \$21,000.00.

Max Neuman & Co., of Boston, Mass., who recently failed owing Providence manufacturers between \$14,000 and \$15,000, are settling at 30 per cent.

A settlement at twenty-five cents cash has been accepted by the creditors in Providence of A. G. Levinson & Co., of Chicago. The Providence claims against this firm amounted to about \$13,000.

Sumner Bros., of Cleveland, Ohio, are endeavoring to make a compromise with their Eastern creditors who are interested to about \$18,000 or \$20,000 for 60 per cent. payable with unsecured notes of 15 per cent. each in 3, 6, 9 and 12 months. It is stated that this offer will in all probability be refused.

A Jeweler who had Grit.

CHICAGO, Feb. 17.—Last evening three men entered the jewelry store of L. F. Hussander as the proprietor was removing jewelry from a show case preparatory to closing up. A revolver was levelled at him, and he was ordered to deliver a tray of diamond rings. Hussander rushed back to his desk and grasped a revolver. One of the robbers fired at Hussander, but missed, and Hussander returned the fire. The men rushed out of the store, the jeweler firing as he ran. When outside the robber returned the fire, inflicting a serious wound in Hussander's leg. Two policemen, attracted by the shots, came, and after a long chase caught two of the robbers in a private residence, where they had rushed in and hidden themselves under a bed. The other man, who escaped, is thought to have been wounded.

Same Old Trick.

BUFFALO, N. Y., Feb. 15.—About a week ago a well-dressed stranger went into the jewelry store of Edwards & Lee, at No. 300 Main street, and said he wished to look at some diamond rings. A tray containing some very beautiful gems was handed out to him, and after examining a number of them he declared he didn't care to buy, and left the store. A short time afterwards one of the firm in looking over the tray discovered that the stranger had abstracted a diamond ring valued at \$155 and had substituted in its place a brass ring with a glass setting. A complaint and a description of the man were at once sent to Police Headquarters, but up to last night the officers had not placed the man.

Where is Aixling?

ADOLPH NELSON, a sailor, swore out a warrant recently for the arrest of George Aixling, a jeweler at 330 Kearney street, San Francisco, Cal., for embezzling a watch left for repair. Nelson stated that he demanded the return of his timepiece, and at last the jeweler acknowledged that he had

pawned it to raise money. Several other of his patrons claim that they have been unable to get back their jewelry left for repairs. Nelson's warrant has not been served, and it is reported that Aixling has fled from the city.

Pacific Coast Notes.

Joseph Rhoder, of New York, has assumed charge of M. Gerwan's optical department at San Diego, Cal.

H. P. Jaccard has refitted his store and purchased a new stock, the best ever seen at Livermore, Cal.

H. C. Warner is selling a \$40,000 stock at auction at Fresno, Cal. This includes a portion of A. Riley's stock.

J. K. Basye, of 804 Front street, Seattle, Wash., has had wonderful success in his special sale of diamond rings.

Joe Glick, of the Diamond Palace at Stockton, Cal., worked up a creditable trade in valentine jewelry this month.

N. B. Hale & Son, the pioneer jewelers of San Bernardino, Cal., have added an extensive engraving department to their business.

HENNEGEN, BATES & CO.

BALTIMORE, MD.,

Manufacturing Jewelers,

DIAMOND IMPORTERS

AND JOBBERS

IN ALL GRADES

AMERICAN WATCHES.

GOLD, SILVER AND NICKEL CASES.

Cor. Baltimore and Charles Streets.

NEW DESIGNS
Class-Rings and Pins

NOVELTIES IN GOLD AND SILVER

OPEN

DaZZle "They are now beautifully made in sterling silver and gold."

RaZZle "Medal very satisfactory."

PuZZle "Class Rings give splendid satisfaction"

Special Designs sent upon request

"Goods give entire satisfaction, well satisfied"

"Received in good order. Pin, which is VERY satisfactory. We wrote yesterday for sample Class Ring and hope to get that order also"

"The young ladies are delighted with Class Rings"

"Many thanks for rushing work ordered."

HENRY C. HASKELL
MAKER OF FINE JEWELRY,
11 JOHN STREET, NEW YORK.

COPYRIGHT PLATES
Sent to Dealers upon request.

Defects of the Escape Wheel.

It is well known that a large escape wheel will set easier than a small one, since more power is required to propel a large wheel than a small one; and in the case of an anchor movement, the pallets are set further from the center of the wheel. Mechanics teach that the further any part is from a given center the more force it will require to move a given weight. We may express it in different words and say that a light pressure will stop a wheel when it is large, simply because of the contact from the center. This can easily be demonstrated by placing one's finger against a wheel in the train of a clock or at the tip of escape wheel teeth, when it will be found that the least touch will cause a stoppage. Should we hold the pinion, however, we will find that it requires much more pressure. It will, perhaps, be useful to know the relative proportions of this pressure to the size of wheels and pinions. It will assist in understanding the subject.

Let us suppose that we have a wheel three inches in diameter, and on the same axis we attach another wheel one inch in diameter; place a piece of cord round the largest diameter and hang a pound weight on the cord. Now wind another cord the contrary way on the small diameter, and it will be found that it requires a 3-pound weight to hold the other in equilibrium. Hence we see, that if one wheel is three times larger than another, it will require three times more pressure before it can acquire its proper propelling force. Of course the escape wheels of watches do not vary so much as this, but the illustration is used simply that the argument may the more readily be understood.

Now, when we consider the proportions from the barrel wheel to the escape wheel, we can easily understand what a vast difference a slight variation in the size of the escape wheel will make in its propelling force; and this is the reason why we frequently see such strong mainsprings used in some of the inferior grade of watches. Were the makers to study well the relative proportions of wheels and pinions, it is certain that they would not employ such strong springs.

After this short digression, let us return to the subject. We must remember that a wheel, if too small, is also very detrimental, since it seems too quick for the other parts of the escapement, and being so much under control of the other wheels it is rather obstinate and not so willing to make its retrograde motion at the proper time. Of course when the balance revolves so as to unlock the pallet the wheel is forced to make this backward motion, but since the pressure is much stronger in a small wheel it must lock very hard, and it is therefore very liable to make a bad action, the same as would be produced by a deep dephing. In other words, the wheel is too quick; for with such a pressure it drops into the pallet jewel sooner than it otherwise would, and is therefore really in advance of the lever and balance. Under these circumstances it is very liable to cut

WE WISH TO ANNOUNCE

That our line of Watches and Jewelry is now complete. Our stock is entirely new, and comprises everything pertaining to the legitimate jewelry trade.

CAN WE SERVE YOU?

KATLINSKY & GATZERT,

WHOLESALE JEWELERS,

96 STATE STREET,

CHICAGO.

R. & L. FRIEDLANDER,

Wholesale Jewelers,

—AND—

JOBBER'S IN AMERICAN WATCHES,

Tools, Materials and Optical Goods,

65 & 67 NASSAU STREET, N. Y.

Factory, 50 BOND STREET.

Send Business Card and we will mail you our Watch and Jewelry Catalogue, No. 12, and our Tool, Material and Optical Catalogue, No. 14.



Try our Monarch American Mainsprings, \$12.00 PER GROSS,
\$1.00 PER DOZEN.

POSITIVELY NO GOODS SOLD AT RETAIL.



FLEUR DE LIS BROOCHES.

ALSO A FULL LINE OF

STERLING . . SILVER . . JEWELRY,

INCLUDING

Love Locket, Brooches, Lace Pins, etc.,

And also in first quality Rolled Plate.

R. BLACKINTON & CO.,

New York Office,

No. Attleboro,

182 BROADWAY,

MASS.

J. R. MORSS.

TRADE MARK **J.G.C. & CO.** MARK

Manufacturers of
FINE Rolled Plate CHAINS.

J.H. Cheever & Co.

North Attleboro, Mass.

BURDON'S • SEAMLESS.

THE ORIGINAL
And only Genuine

The success of the BURDON SEAMLESS FILLED WIRE, like that of all important inventions, has been followed by deceptive and imperfect imitations. For the protection of

ALL JOBBERS AND RETAILERS,

we authorize manufacturers who so desire, to affix upon the tag, card or label accompanying the articles made from this wire, this registered trade-mark owned by this Company.

The bird-on-wire is a guarantee that the goods are made from the original Burdon Seamless Filled Wire, the reputation of which has been firmly established among the best dealers for more than two years. The perfection and qualities of the Burdon Seamless Wires are always guaranteed. All Dealers (jobbers and retailers alike) should, therefore, demand goods made from the original Burdon Wire, and avoid imitations which are offered as "just as good."

BURDON SEAMLESS FILLED WIRE CO.,

109 to 119 and 127 Summer Street,
PROVIDENCE, R. I.

GENTLEMEN:—I think the trade this Spring will be better than last, and, although I can turn out double the work I did then, you had better be on hand with your orders, for I expect that my sales will be very large—equal to last Fall, if not double. You see the field is constantly widening and the demand is increasing, and why? Did you ever stop to think that there are 65,000,000 people in the United States, and the per cent. of this number that use glasses is one-fifth, or 20%, making 13,000,000 people wearing eyeglasses, and if you count the myriads in Europe and South America, why it is simply immense, and it needs cultivation. Why! Gentlemen, we ought to be able to double our business every year for the next ten years.

Yours respectfully,
Springfield, Mass. S. F. MERRITT.

PETER HENRY,

MAKER OF

Special Watch Cases

For American, English and Swiss Movements,

No. 56 Longworth Street,

Room 4, Second Floor, CINCINNATI, O.

Key Winders changed to Stem Winders.
English Cases changed to fit American Movements.

Hunting Cases changed to Open Face.
Old Watch Cases Reconstructed, Repaired and Renewed.

LOW PRICES, GOOD WORK AND PROMPT ATTENTION GUARANTEED.

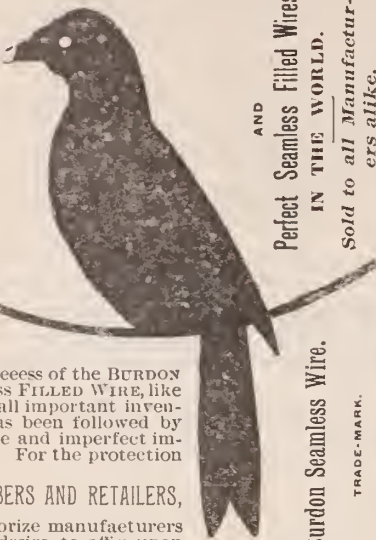

AND
Perfect Seamless Filled Wires
IN THE WORLD.
Sold to all Manufacturers
alike.

Burdon Seamless Wire.

TRADE-MARK.

the pallet jewels or to get its teeth much worn.

A short time ago an escapement of this description was under repairs. It had a very broad escape wheel, and the pallet jewels were very round, so that only a small portion came in contact with the wheel, which was perfectly flat, and the jewels caught each tooth exactly in the center. The watch had been going only about eighteen months, but the pallets had so "pitted" the wheel, owing to the excessive force, that all the front parts of the teeth were quite worn out of position.

This will also occasionally happen when a particle of oilstone dust or any similar substance gets on the wheel teeth or pallets. When the wheel has sufficient metal this can be remedied by carefully filing the front part of the teeth until the "pits" are taken out. But it requires care, as the file must be held exactly in the same position with the angle of the teeth. If this is not observed the wheel will probably be ruined, since no good action can be expected of a watch when the angle of its escape wheel teeth has been disarranged.

New York, Feb. 13, 1891.

Dear Sirs.—The returns from our advertising in your paper have so far exceeded our expectations that we deem it advisable to double the size. Please do so in your next issue.

Hildreth Manufacturing Co.

A Singular Recovery of Goods.

ON the night of the 3d of July, 1887, the jewelry store of S. M. Creighton, of Sabina, O., was burglarized and a large number of rings and other jewelry taken. After much searching Mr. Creighton failed to recover the goods and gave them up as lost. Last week he received word from Midland City that the station agent at that place had discovered the goods hidden in a hollow tree near town. Mr. Creighton went up to Midland City and identified the goods, all of which were in good condition. A Waterbury watch, which was among the stolen articles, was wound up and immediately resumed business at the point where it left off four years ago.

San Francisco.

The West Coast Jewelry Company was reprimanded by Judge Rix, the other day, for falsely accusing Felix A. Wiener, a young clerk, of theft.

William Wilson, a well-known jeweler of this city, has sold his beautiful residence in Alameda, and will erect a more commodious dwelling in the same pretty suburban town.

The American Jewelry Association has caused the arrest of a young man named James T. Donlan, who was employed by the firm to sell gold watches on the installment plan. Donlan stole three watches valued at \$100 each. After his arrest it was developed that Donlan had defrauded the Occidental Watch Company, of No. 24 Post street, and the jewelry house of Borneman & Street, out of \$100 each.

Use and Abuse of the Magnifying Glass.

ALTHOUGH it is the opinion of eminent ophthalmists that the judicious use of the magnifying glass is by no means injurious to the eye, it is well to point out that this opinion is but conditional, and does not apply to its abuse. On this subject a correspondent of the *Deutsche Uhrmacher Zeitung* says that a watchmaker more often than not thinks to make use of his ordinary sight. It is, then, the duty of the master to make the pupil appreciate from the beginning of his apprenticeship the advantage he will find in the employment of the naked eye, and how much time and pain he will by that means avoid; especially in measurings and rough work. Want of habit in the estimation of sizes, or rather in their exact comparison; inexperience, variety, or convenience; perhaps also the idea of giving more rapidly to the eye the necessary dexterity—all are apt to induce beginners to use the eyeglass which they see employed by the more advanced apprentices. They do as the clown who, not knowing his alphabet, thinks that by putting on spectacles he will be able to read immediately. The responsible master should absolutely forbid the eyeglass to the beginner, and not permit its use until actually necessary. The habit which at first was only due to vanity or inexperience, becomes in time fixed.

But what a grotesque and at the same time deplorable effect! Only certain pieces are produced, the thick pieces hardly roughed out, when made by the aid of the glass. It is no excuse to say that the work has been badly done because the workman has bad eyes. If he has not good sight let him put on suitable spectacles. There are many watchmakers who rarely use the eyeglass and when they do it is only for fine work.

What can be done by one can be done by others. Nothing is requisite but a firm will.

Those who are not able to dispense with the eyeglass, commit also from habit the unpardonable fault of using glasses too strong, which leave an interval of only two or three centimeters between the work and the glass. This is pernicious to the eyes, because in using short focus glasses the eyes become pained, and if they are continued an enfeeblement of the sight is produced. And in consequence of the excitation of the optical nerves headaches result, which in some circumstances may become chronic. The eyeglass for ordinary use should be weak and allow of an interval of from six to eight centimeters between it and the work. It is quickly got used to and will not produce tiredness of the eyes. Besides the weak glass, it is necessary to have a strong pebble eyeglass, but the latter is required very seldom.

With use it sometimes happens that when the eyeglass is held a long time near the eye the glass becomes blurred. This is very disagreeable, and proceeds from the vapors which emanate from the eye and become condensed on the eye-glass. It is easy to prevent this by making two holes opposite one another, so that the interval between the eye and the glass may have communication with

the exterior air. These holes are made just above the glass, so that the current of air circulating touches it lightly and prevents the condensation. The lenses of eye-glasses are wiped ordinarily with an old piece of linen or with the leather. Both are bad, because in proceeding thus the glass is covered with imperceptible rays. It is preferable to make use of silk, or still better, of unglazed porous paper that is not frayed, or filtering paper. Breathe lightly on the glass before wiping it.

To Sell the Property of the Lancaster Watch Company.

LANCASTER, Feb. 14.—Before the court here to-day H. B. Swarr, attorney for D. Ramsey Patterson, assignee of the Lancaster Watch Company, made application for an order permitting him to sell the real estate and personal property of the company in this city. The application stated that the factory was subject to a mortgage of \$50,000 and asked that no bid of less than \$60,000 over and above the amount of the mortgage be considered. The date for the proposed sale was fixed as April 7. Owing to an informality in the application, it went over until next week, when it will probably be granted.

This will undoubtedly end the existence of the Lancaster Watch Company, which under many names has had a very unfortunate existence for the past seventeen years. In all probably three-quarters of a million of capital have been lost in the enterprise.

He Wantonly Cut Windows.

ON Tuesday February 17th, the business men on the east side of Fulton street, from Sands street to Myrtle avenue, were astonished to discover that during the preceding night some miscreant had blemished their plate glass show windows with a diamond. About thirty windows were so affected. The cuts were in almost every instance at elbow height from the sidewalk, and it seemed as if the perpetrator had performed his work as he walked along the street.

The jewelry stores which were touched were those of Benj. F. Spink, at No. 329, the J. R. White Jewelry Company, at No. 331, D. J. Dyer, at No. 347 and the jewelry and bric-a-brac auction store of L. Scheiber. At Liebmann Bros. & Owing's store the person had cut a ring and had evidently endeavored to punch out the disk of glass, for the plate was fractured.

The damage done lies mainly in its effect upon the beauty of the show windows. There is no clue to the perpetrator.

To restore the position of the chain in an English Lever Watch.—Sometimes, because of a defect in the fusee, the chain of an English lever watch will fall over flat on the barrel. It can be restored to its proper position with the point of a graver in the circumference of the barrel, by forcing this forward, thereby taking off the power of the main-spring. And the defect in the fusee can often be corrected without taking the watch down.

DIAMONDS.

Wm. S. Hedges & Co.,
Importers of Diamonds,

And Manufacturers of DIAMOND JEWELRY.
 No. 170 BROADWAY, } New York.
 S. E. Cor. Maiden Lane, }
 27 Holborn Viaduct, London.

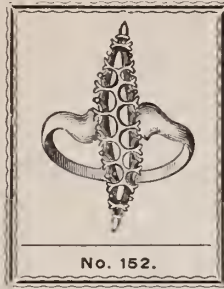

STERN BROTHERS,
"S"

A "NOVELTY" in Marquis Rings.

SEND FOR SAMPLE.

Manufacturers of Fine DIAMOND MOUNTINGS.

42 MAIDEN LANE, N. Y.

START!

R. A. Kipling

Importer of Precious Stones

31, Union Square
 New-York

19, Rue Drouot
 Paris

THE WALTHAM SCHOOL OF HOROLOGY,
 D. D. PALMER, Teacher and Proprietor.

Best Advantages in the Country for Horological Instruction.

All branches under the personal supervision of D. D. PALMER, for a number of years in charge of the Adjusting Department of the Waltham Watch Co. POSITIONS GUARANTEED TO APT PUPILS. For terms and other particulars, address

D. D. PALMER,
WALTHAM, MASS.
 Specialty of Difficult Repair Jobs.

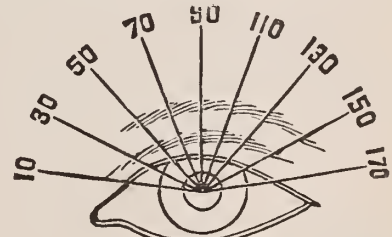

SEND TO
GENEVA OPTICAL CO.

23 Washington St., Chicago.

FOR PRESCRIPTIONS, REPAIR AND ORDER WORK PROMPTLY AT LOWEST PRICES.



"GET THE BEST."

American Tools are the Best.

O. W. BULLOCK & CO.,
 Springfield, Mass.

Manufacturers of WATCH TOOLS.

LARGEST LINE IN THE UNITED STATES.

Send 4 cents for postage on new catalogue.

ASK YOUR JOBBER FOR

The Sun



INTERCHANGEABLE INITIAL RING.

H. LUDWIG & Co.
 MANUFACTURERS OF
NOVELTIES IN JEWELRY
 LARGEST MFG. OF
 POPULAR PRICE JEWELRY IN U.S.

NEW YORK OFFICE,
 PRESCOTT BUILDING,
 ROOM 40. SAMPLES ONLY.

WORKS, BLACKSTONE & GAY STS.
 TAKE PRAIRE AVE CAR.

Providence, R.I.

Established 1872.
PLAINVILLE STOCK CO.

P. S. CO.
 THIS TRADE-MARK REGISTERED, AND STAMPED ON ALL OUR GOODS.

BROOCHES, SCARF PINS, DROPS, SETS.
 FACTORY AT PLAINVILLE, MASS. SAMPLES AT 176 BROADWAY, NEW YORK.

MOORE & HORTON,
 MANUFACTURERS OF
SOLID GOLD JEWELRY,
 No. 11 Maiden Lane, New York.
Fine Imitation Diamond Goods a Specialty.
 Selection Packages sent on Application.

A. J. GROENMAN & CO.,
DIAMOND CUTTERS,
 80 Nassau Street,
 NEW YORK.
SMALL MELEE A SPECIALTY.

N. SCHWARZ,
 MANUFACTURER OF
 VELVET AND LEATHER CASES,
 866 Broadway, New York.

GILBERT T. WOGLOM
BLACK ONYX MAKER OF Pearl Ornamented and Plain
 JEWELRY, GOLD MOUNTED.
 32 & 34 John St. New York City.

PHOTO CHEMICAL ENGRAVING
 BARTHOLOMEW SPECKHART
 110 SPRUCE ST. N.Y.

MUSICAL BOXES. JACOT & SON,
 298 Broadway, New York
 Send for Catalogue.
 Musical Boxes Repaired.

G. F. FEINIER,
 MANUFACTURER OF
WATCH CASES,
 Repairing of Every Description,
 NO. 9 BOND STREET, NEW YORK.
 Key-Wind Cases Altered to Stem-Wind, and made same as New. English Cases Altered to take American Movements.

HOW TO RECOGNIZE THE TRUE

WEBSTER-WHITECOMB · LATHE.

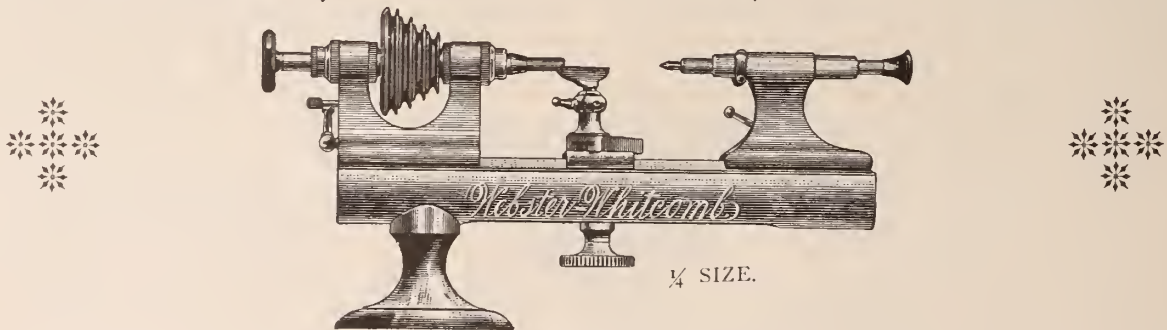

THIS question is often asked: "How shall I recognize an *imitation* from the *true* 'Whitcomb' or 'Webster-Whitcomb' lathe?" To this we reply: "All our lathes bear the word 'Whitcomb' or 'Webster-Whitcomb' also the word 'hard' or 'soft' to indicate the temper of the bearings, also the number of the lathe (all of our lathes being numbered consecutively) either on the bed or the headstock (latterly on the headstock only). The bed always bears the words 'American Watch Tool Co., Waltham, Mass.' The words 'Whitcomb' and 'Webster-Whitcomb' are our trade-marks, and up to the present time no imitator has dared to use them. The first attempt to use them or our patented features will be immediately followed by a suit at law. With every lathe we send the following guarantee:—

"This certifies that the lathe marked 'American Watch Tool Co., No. —' was made by us from the best materials, on the most approved plan, and is a reliable lathe. For any defect in material or workmanship we hold ourselves responsible. Notify us promptly of any faults.

"Waltham, _____ By _____"

This guarantee is also signed by the inspector who has the final inspection of the work. For several years past we have tied upon every lathe a tag of caution and instruction. All purchasers are requested to demand these documents with the lathes they buy. Remember our address:

AMERICAN WATCH TOOL CO.,
 WALTHAM, MASS

STONY BATTER WORKS.

Polishing Powders for use in Horology.

NOTHING is more necessary to the successful use of polishing powder than the equality of the grain. Fine dust clogs the action of coarse grinding powders, and prevents them from cutting with rapidity the object to be ground; coarse particles mixed with fine polishing powder scratch the article to be polished, and render regrinding and repolishing necessary. To secure fineness and uniformity, no process equals that of electricity, which is thus performed:

To separate the ordinary flour of emery into three different degrees of fineness, take three vessels, such as tin pails or glass jars, and mix the emery with a large quantity of water—say a quart of water to 1½ ounces of emery. Stir the mixture until the emery is thoroughly diffused through the liquid, and allow the mixture to stand five minutes. By this time all the heavier particles will have settled, and when the fluid is poured into a second jar only the finer portions will be carried over. So continue to wash the first residuum until nearly all the particles have subsided and at the end of five minutes the water is left comparatively clear. The coarse portion, No. 1, will now be by itself.

So from the sediment collected from the washing of No. 1, you may collect a portion. No. 2, having a second degree of coarseness. The last and finest will be obtained by letting the finest workings stand ten or fifteen minutes, pouring off the liquid and allowing it to settle.

The principal polishing powders are chalk or whiting, rouge, emery, oilstone powder, and putty, which latter consists chiefly of oxide of tin. Other powders, such as tripoli, bath brick, sand, etc., are rarely used by the jewelers.

CHALK OR WHITING.

Chalk is a native carbonate of lime, consisting of the remains of minute creatures known as *foraminifera*, and when simply scraped or crushed under a hammer or runner, it is sometimes used for polishing such soft substances as bone, ivory, etc. As it contains particles of silica of varying size it cuts freely, but is apt to scratch. To remove the gritty particles, the chalk is ground and the fine parts separated by washing. It then becomes whiting, which is generally sold in lumps. Whiting has very poor cutting qualities, and it is therefore used chiefly as *plate powder* for cleaning gold, silver, glass, etc., and for absorbing grease from metals which have been polished by other means. The washing process for the common chalk is essentially that described for emery.

PREPARED CHALK.

This is a manufactured article, prepared by adding a solution of carbonate of soda to a solution of chloride of calcium, both cheap salts, until it is precipitated. The solution should be carefully filtered through paper before being mixed, and dust should be carefully excluded. The white powder which falls down is carbonate of lime, or chalk,

and when carefully washed and dried, forms an excellent polishing powder for gold and silver. The particles are almost impalpable, but seems to be crystalline, for they polish quickly and smoothly, though they seem to wear away the material so little that its form or sharpness is not injured to any perceptible degree.

CROCUS OR ROUGE.

These articles are generally manufactured by persons who make the manufacture their sole occupation, in the following manner:

They take crystals of sulphate of iron, green vitriol or copperas, immediately from the crystallizing vessel in the copperas works, so as to have them as clean as possible, and instantly put them into crucibles or cast-iron pots and expose them to heat, without suffering the smallest particle of dust to get in. The portions which are least calcined and are of a scarlet color, are fit to make rouge for polishing gold or silver, while those which are calcined or have become red, purple or bluish-purple form crocus fit for polishing brass or steel. Of these the bluish-purple colored parts are the hardest, and are found nearest to the bottom of the vessel, consequently, they have been exposed to the greatest degree of heat.

TO PREPARE OXIDE OF IRON.

Mr. Andrew Ross's mode of preparing oxide of iron is to dissolve crystals of sulphate of iron in water, filter the solution to separate some particles of silex which are generally present, and sometimes are abundant. Then precipitate from this filtered solution the protoxide of iron, by the addition of a saturated solution of soda, which must also be filtered. This grey oxide is to be repeatedly washed and then dried. Put it in this state into a crucible and very gradually raise it to a dull red heat. Then pour it into a clean metal or earthen dish, and while cooling it will absorb oxygen from the atmosphere and acquire a beautiful dark red color. In this state it is fit for polishing the softer metals, silver and gold, but will scarcely make any impression on hardened steel or glass. For these purposes it will be found that the black oxide effects the polish, and this gives to the red oxide a purple hue, which is the criterion of its cutting quality. Therefore, for polishing the harder materials, the oxide must be heated to a bright red, and kept in that state until a sufficient quantity of it is converted into black oxide to give the mass a deep purple hue when exposed to the atmosphere. An experimenter converted the whole into black oxide. This, however, is liable to scratch, and does not work so pleasantly as when mixed with the softer material. The powder must now be levigated with a soft wrought iron spatula, or upon a soft iron slab, and afterwards washed in a very weak solution of gum arabic. The oxide prepared in this manner is almost impalpable, and free from all extraneous matter, and has the requisite quality in an eminent degree for polishing steel, glass, the softer gems, etc.

TO PREPARE THE PEROXIDE OF IRON.

Lord Ross, in speaking of his method of preparing the peroxide of iron, says: "I prepare the peroxide of iron by precipitation with water of ammonia from a pure dilute solution of sulphate of iron. The precipitate is washed, pressed in a screw press till nearly dry, and exposed to a heat which in the dark appears a dull, low red. The only points of importance are, that the sulphate of iron should be pure, that the water of ammonia should be decidedly in excess, and that the heat should not exceed that which I have described. I have tried both soda and potash, freely, instead of water of ammonia, but after washing with some degree of care, a trace of the alkali still remained, and the peroxide was of an ochrey color till overheated and did not polish properly.

OILSTONE POWDER.

The Turkey oilstone can hardly be considered as a hone slate, having nothing of a lamellar or schistose appearance. As a whetstone it surpasses every other brown substance, and possesses, in an eminent degree, the property of abrading the hardest steel. It is at the same time of so compact and close a nature as to resist the pressure necessary for sharpening a graver or other small instrument of the same description. Little more is known of its natural history than that it is found in the interior of Asia Minor, and brought down to Smyrna for sale. The white and black varieties of Turkey oilstone differ but little in their general character. The black is, however, somewhat harder, and is imported in larger pieces than the white.

Fragments of oilstone, when pulverized, sifted and washed, are much in request by mechanics. This abrasive is generally preferred for grinding together fittings for mathematical instruments, and is superior to pumice stone powder for polishing superior brass work; it is also extensively used by the watchmaker on rubbers of pewter in polishing steel.

PUMICE STONE POWDER.

This powder is extensively employed in various branches of the arts, and particularly in the state of powder, for polishing the various articles of cut glass; it is also much used for dressing leather and in grinding and polishing the surface of metallic plates, etc.

PUTTY POWDER.

Putty powder is the pulverized oxide of tin; generally of tin and lead mixed in various proportions. Concerning the quality of the putty powder, it may be said that the whitest is the purest, provided it be heavy.

VIENNA LIME.

Vienna lime and alcohol give a beautiful polish to iron or steel. Select the soft pieces of lime, such as can be easily crushed by the thumb and finger, as they are the most free from gritty particles. Apply with a cork, piece of soft pine wood, leather or chamois.

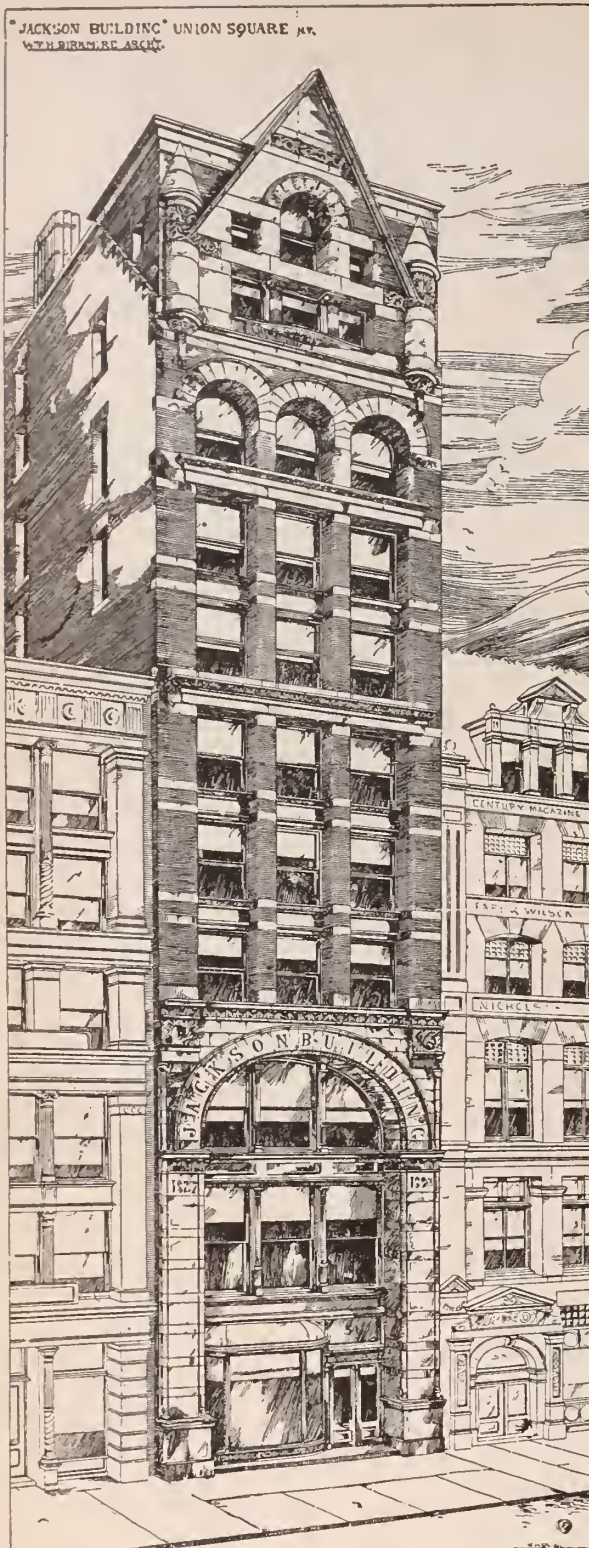

Kansas City, Mo.

J. Niles Kimball & Co., have moved to new quarters on West Sixth street.

E. H. Froder has gone on the road for H. Oppenheimer & Co. He has been with this firm for nearly fifteen years.

M. W. Moody, of Nevada, Mo., Frank Nevin, of St. Joseph, A. Gluck, of Dodge City, Kan. and E. A. Jones of Topeka, were in the city last week.

Charles Richards, late of El Dorado, Kan., was in the city last week buying a stock for his new store which he will soon open in Granite, Mont.

Herman Oppenheimer and Herman Streicher have returned from Chicago where they attended the banquet of the Jewelers' Association of that city.

Barr McClune, whose place of business is on Walnut street, opposite the Midland hotel, made an assignment on Thursday, February 12, to M. M. Allen as trustee for his creditors. The liabilities are small and are fully covered by assets. The principal indebtedness is to Woodstock, Barger & Hoefler, H. E. Wuerth, L. E. Meyer, and the L. E. Meyer Jewelry Company, Cady & Olmstead, Barbour Bros., Smith, Lesquereux & Co., Petton Bros. & Co., Kossuth, Marx & Co., and Dr. W. H. Kimberly.

New Bedford, Mass.

Joseph K. Nye, with the William F. Nye watch oil works, has sold his handsome sloop yacht, Prince Karl, to D. S. Meeker, of Newark, N. J.

John F. Strange, of this city, has just patented a useful and novel device in optical goods, which bids fair to make a decided impression on the market. He calls it a visual concentrator. The instrument consists of two metallic cups made oblong at the base so as to fit the bows of spectacles, to which they are attached by little hook-like projections. These cups are perhaps an inch long, and the outer end is rounded. In it, placed obliquely, and somewhat around on the inner side of the cups, are small almond-shaped holes set at such an angle that their lines of sight, when produced, meet at a fair reading distance. The inside of these cups is enameled a dull black so that little or no light can get in. All the power of sight is by this instrument concentrated on the focusing point of the two holes, so that the object viewed is seen much plainer and clearer, but still not magnified. Persons whose sight is but slightly impaired are said to receive much assistance from the instrument without the use of lenses. Several well-known oculists, among them Dr. J. J. B. Vermyne, secretary of the American Otolological Society, have examined the instrument and endorse it as a complete success. Mr. Strange is having them made in considerable quantities by a Providence firm, and finds a ready market for them.

Especially designed
for Jewelers' Offices
and Factories.

Wired for Electric
Light and Power.

Hydraulic Freight
and Passenger Ele-
vators.

Iron Beams with
Brick Arches be-
tween.—Fireproof.

Facing Union
Square.

In the centre of the
Fine Jewelry Trade.

Thoroughly Heated,
Lighted and Venti-
lated.

Containing every
modern comfort and
improvement.

—IN THE FIREPROOF—
TO LET JACKSON BUILDING,
Union Square, New York,
STORE AND LOFTS, 28.6 x 184 Feet.

Will Be Ready May 1. Apply to

J. EDGAR LEAYCRAFT, 1544 Broadway, * *

—OR—

* * ALFRED E. MARLING, 150 Broadway

The Jewelers' Circular.

TO THE RETAIL TRADE:

THE JEWELERS' CIRCULAR, realizing the demand for the change, is now issued weekly instead of monthly. The new form is the same as that which has received your kind patronage for over twenty years, and whatever changes have been and will be made, will be in the line of improvements. The management fully realize that the ideal trade journal must satisfy the demands of every branch of the industry it represents—manufacturer, jobber, retailer, and workman. It has been the aim of THE CIRCULAR from its inception to carry out this ideal, furnishing for every branch of the trade matter of solid and permanent value. The same policy shall guide the paper in the future. No single interest will be neglected. The repairer at the bench, the jeweler, the goldsmith, the silversmith, the retail dealer, the jobber, the manufacturer, all will continue to find in its columns much that will be practically helpful to them in their business. The retail jeweler is the real consumer and it is most important that his interest should be well cared for, and there is no better organ for this purpose than a good trade journal. It will accordingly be the aim of the management in the future, as it has been in the past, to keep steadily before their eyes the varied interests of the retailers. Although THE CIRCULAR is essentially a newspaper, but the more solid features that have characterized it in the past will be continued and improved, and much news matter bearing specially on the retail trade will be introduced.

In its new weekly form, THE CIRCULAR will present a variety of attractive features in its many departments, including:

HOROLOGICAL ARTICLES—Articles on Horological matters which have made THE CIRCULAR celebrated throughout the civilized world will still form a most prominent feature. The same staff of excellent writers has been retained and others added.

GOLD AND SILVERSMITHING ARTICLES—Articles in this line including Silver-smithing, Plating, Enamelling, Encrusting, Engraving, Damaskeening and other branches, by the best writers will be published.

OPTICAL ARTICLES—The series of optical articles which have been a feature of THE CIRCULAR, and which have proved an efficient auxiliary to the education of numerous jeweler-opticians will be continued.

FASHIONS—"ELSIE BEE," the best fashion writer in the country, will continue to contribute.

NEWS DEPARTMENT—An efficient corps of correspondents having been engaged in every town in the country, the best facilities for obtaining news is at our command. News matter of interest to all branches of the trade will appear.

LEGAL DEPARTMENT—Digests of characteristic law cases throughout the country, and jewelry and kindred patents recorded.

CORRESPONDENCE—Communications from the trade will appear; questions are solicited and answers will be fully explained by able writers.

MISCELLANEOUS MATTERS—Such as a Humorous Department, Personal Items, Roundabout Notes, Sketches, Stories, Anecdotes, etc.

SPECIAL ARTICLES—On window dressing, store decoration, and other subjects to attract customers and increase business.

SEE OTHER SIDE.

BEING convinced that after a fair trial you will find it to your advantage to take

The Jewelers' Circular

regularly, we offer the following inducements to new subscribers:

UPON RECEIPT OF TWO DOLLARS

(the price of one year's subscription), we will send THE CIRCULAR for one year (52 numbers) to any address, and a copy of our book of **Monogram Plates**, which contains **44 Plates** or **2,112 Monograms** in all, in six different styles. Or, for

50 CENTS, WE WILL SEND

The Jewelers' Circular

For **SIX MONTHS** on trial.

Either of the blanks given below, if filled out and returned with the proper amount of money, will secure for you one of the best trade journals in the world for the time stated.

189

TO THE Jewelers' Circular Publishing Co.,
189 BROADWAY, NEW YORK.

Enclosed please find TWO DOLLARS, for which send THE JEWELERS' CIRCULAR for One Year, beginning _____ and one book of Monogram Plates.

NAME, _____

ADDRESS, _____

189

TO THE Jewelers' Circular Publishing Co.,
189 BROADWAY, NEW YORK.

Enclosed find FIFTY CENTS, for which send THE JEWELERS' CIRCULAR for SIX MONTHS, on Trial, beginning _____

NAME, _____

ADDRESS, _____

The Other Side of Life.

'Tis when we have a pain in the eyes that we remember "the eye is the window of the soul."

MATHEMATICAL.

Mr. Cynicus—I wonder, Miss Caustique, what proportional part of her life a woman of fifty years has occupied seeing that her bonnet was on straight.

Miss Caustique—Mathematicians have calculated that a man of seventy has spent three years in swearing while looking for a lost collar button.

A PROBLEM IN ADDITION.

Miss Ambrosia Pas ee g'glingly—Do you know I reached my birthday to-day? Well, now, how old do you think I am?

Mr. Dillidally (gallantly)—Seventeen and a bit.

Mr. Sillibilly—About twenty-three.

Miss A. Passee—And Mr. Haysede, what do you think?

Mr. Haysede—Wal, takin' it all t'gether I guess the gentlemen is right.

CAUSE FOR NIGHTMARE.

Cholly Cholmondeley—Had tewwible dweam last night.

Harold Harrington—Dweam your twowers were not pussed?

Cholly Cholmondeley—Worse. Dweamt of my ancestors. Nevah like to dweam of my ancestors; they were all twadesmen.

SHE WILL KEEP HER PROMISE

Mrs. Magnus Scott—I promised not to ask you to buy me any diamonds during Lent.

Mr. Magnus Scott—You did, my dear,

Mrs. Magnus Scott—And I mean to keep my promise too. Now I saw at Timpany's yesterday a charming pair of ruby earrings which just carried me away. They may be

a little more expensive than diamonds but I hope you will get them. You see, dear, they are not diamonds.

Alice—Have you ever noticed the ring in Harold's voice?

Gwendolin—Not particularly.

Alice—I have. Last night for instance. He asked me to be his. There was a regular engagement ring in his voice.

A WONDERFUL ACHIEVEMENT.

"You see that old man opposite?"

"Well?"

"He has been wearing spectacles since a boy of five years. He is so used to them that he can them put them on his nose with his eyes shut."

WENT MINNIE ONE BETTER.

Little Miss Minnie (proudly)—My mommer wears big diamonds.

Little Miss Mamie (disdainfully)—Huh! what's that. My popper smokes fairly good cigars.

AS USUAL.

Wife. You wanted to get up early. Now you are awake, why don't you rise up?

Husband. I'm waiting for the clock to strike.

WHY, INDEED?

Little Minnie—When was it, mommer, that you had four eyes?

Mommer—Don't talk nonsense, Minnie. I never had four eyes.

Little Minnie—Then, why does everyone say I got my eyes from you?

PROGRESSION VS. CONSERVATISM.

Mr. Repousée (young modern merchant)—It is said that old Louis Quatorze should have pawned his memorandum goods.

Mr. Roccoco (old conservative merchant)—He did not pawn the goods; he only hypothecated them.

'T WAS A DREAM.

New Yorkian (in Philadelphia)—Can you tell me the time?

Philadelphian (looking at watch)—Quarter to five o'clock; but my watch is five minutes fast.

New Yorkian—Fast! Friend, what city is this?

Philadelphian—Philadelphia, of course. (There were a whirring and a thumping of a heavy body which gradually settled down on the New Yorkian's chest. There it pressed him and caused him to awake, and, with a cold sweat covering his body, he found it was only a dream.)

ROYAL JOCLARITY.

Lord Salisbury—Have you ever calculated, your highness, the number of umbrellas you have used since you ascended the throne?

Queen Victoria—I suppose no more than other folks.

Lord Salisbury—I was thinking you did. You know we have had fifty years of continual reign.

And Lord Tweedledum and the Marquis of Bareacres burst out in a loud haw-haw.

The Spring Collet.

The repairing watchmaker should see that the collet fits properly and is well made. The spring-collet arbor of the balance staff must be slightly the largest in the centre, so as to allow the collet to press nicely down. If it fits too tightly there is great danger of bending the balance over or of setting the rim out of truth in taking it off, which may have to be done several times during the adjustment of a watch. A collet should never be squeezed up to make it fit; it is a mischievous proceeding causing annoyance to every one who attempts to handle it.

ALVIN MFG. CO.,

Silversmiths,

860 Broadway, New York,

206 Kearney St., San Francisco,



DESIGN—OYSTER SHELL—SALT.

MADE IN LARGER SIZES FOR ASH TRAYS, &c.

Design Patented.

NOTICE.

Intending to retire from business, we offer for sale our fine stock of *Diamonds, Rubies, Emeralds, Sapphires*, etc., either the *whole* or in *lots* of any size. Also *fixtures*, consisting of fire and burglar-proof safe, desks, cloth-covered tables, diamond scales, office partitions, etc., etc.

This presents a fine opportunity for a party to purchase a successful business, with a first class *clientelle*. Part of office to rent.

PETERSON & ROYCE,

189 Broadway, New York.

Lathes and Lathe Work.

BY THE MODEL WATCHMAKER.

THE most difficult parts of making a slide rest have now been described. How to put the parts together will not usually prove itself difficult to any workman who is capable of making the parts. It might not be amiss, however, to tell how the tool post is attached to the upper slide. This part is usually cast fast to the upper plate, and the under cut groove in which the foot of the tool post rests, is milled out. Of course, in getting up a slide rest in the ordinary workshop, such tools and conveniences are not always at one's disposal. By getting up two pieces shaped as shown at C (Figs. 1 and 2) and screwing them to the bed, A, we will have a substantial and convenient arrangement for holding our post. The methods for holding the tool in use by several of the slide rests now on the market, admit of but little improvement, consequently the writer will offer no suggestions.

We will now go back to the original purpose of these articles and take up our wheel-cutting device. There have been a good many valuable ideas and improvements given to the trade recently in regard to wheel-cutting machinery, but still for the practical man there is so much that remains to be said. The practical man wants a cheaper device for the purpose, and in this article we propose to furnish an attachment that can be used with the slide rest we have been describing and making; or it can be applied to any other slide rest.

The first thing to make is an arbor for holding the cutter. As much depends on the accuracy of this portion of the device, we propose to tell how to make one that shall be free from many defects which seem to creep into such tools. We all know that an arbor should run absolutely and perfectly true if we are to use a cutter with more than one cutting edge, as is the case with the so-called "fly cutters."

To make an arbor for holding cutters, take a piece of stub steel wire about five-sixteenths of an inch in diameter and two inches long, as shown at E, fig. 3. Drill a small hole in each end of it as shown at 3, c, and countersink the holes as shown. Next turn the piece of wire a little taper as shown at d d. The piece E is now drilled with three holes at right angles to its axis as shown at F, and the holes are then filed into a slot as shown at f, fig. 4, which is a side view of fig. 3, seen in the direction of the arrow, g.

It may be well to be careful in describing the slot at f, as it should cause the cutter when in position to rest flat and squarely on the shoulder, G. The upper end of the slot f, is not mortised straight through, but has a V shaped edge, as shown at n, fig. 3. The arrangement of the parts will be understood by inspecting fig. 5. Here we have shown the finished arbor. The collar G, is a fixture on the arbor. The cutter h, is placed on the arbor, and the yoke i, put through the slot f, so the end j, rests on the cutter h, as shown in fig. 5, while at the opposite end a screw, k, bears on the cutter. It will be seen by

this arrangement that a perfectly even pressure is obtained on the cutter.

If the reader will reason on the subject he will see that an even pressure obtained by means of a screw cut on arbor is almost impossible, even if we had the screw on it cut with a lathe; because the process of hardening would more or less distort the screw. But by the arrangement shown the pressure is even and has no tendency to spring the arbor. To be more explicit in the details of construction, the writer would say that the arbor, E, after being roughed out as described, is hardened and the ends left as hard as possible, while the portion between the lines c c, is reduced so that it can be turned to perfect accuracy. The collar or the disc, G, should be about $\frac{1}{4}$ of an inch thick made of hard, red brass and driven on the arbor after it is hardened and the temper reduced.

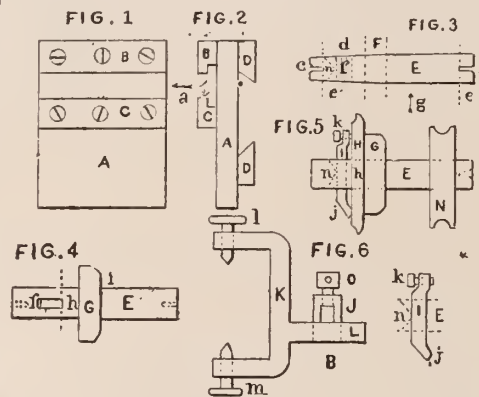

It will be noticed that there is a blank or smooth portion of the arbor, E, at n. This must be very carefully turned after the hardening and tempering to insure perfect steadiness and truth in the cutter. If the reader has a parallel grinder the arbor, E, need not be reduced below a straw color. Of course it is to be understood that the collar or disc, G, is turned and faced off after it is on the arbor. The arbor just described is mounted in a holder, shaped

as shown at K, fig. 6. The part shown at I has a hole which goes over the tool post when a fire steel is put across the part I, and the screw, O, is set down upon it to hold it in position. The screws, l and m, enter the holes, v and c, and by moving these screws up and down the cutter can be adjusted to any height, so as to present the cutter properly to the wheel to be cut. It should be understood, of course, that the wheel to be cut is mounted on the cutter spindle.

The writer is well aware that the form of arbor shown is an innovation on all arbors of this kind in use, but he thinks the improvement in action will amply compensate for its newness.

This kind of a wheel-cutting device can be driven by a bow or by a counter-shaft. For cutting stem vining wheels or pinions, the bow method is as desirable as any, but for brass wheels the fly cutter is the one to employ. In getting up the countershafting for running a fly cutter it is imperative that a very high velocity be obtained, a hundred and twenty-five revolutions per second being about as slow as is safe. For using a fly cutter it makes a better device to not depend on the foot wheel, but to get up a system of pulleys to be actuated by hand, letting some assistant produce the motive power in order to get a constant speed.

The cutter shown at H (fig. 5), is one known as a wolf tooth cutter, and is employed principally in Swiss stem wind works; there is no especial difficulty in getting up such cutters, since all that is required is to turn them off the proper shape and then with a graver, to cut all that part of the cutter which is to act as a cutter into a fine line, using care that the spaces between the lines approach to an edge and so form a cutting angle.

It is difficult to obtain soft steel from which to make cutters, but such steel can always be purchased of those who furnish steel for engravers' use.

ESTABLISHED 1837.

GEO. O. STREET & SONS,

MAKERS OF

Fine Rings, Lockets, Seals, Sleeve
Buttons and Links,

15 John Street, - NEW YORK.

MAXHEIMER & BERESFORD,

MANUFACTURERS OF

FINE DIAMOND JEWELRY,

No. 3 Maiden Lane, New York.

ORDER WORK A SPECIALTY

JOHN A. RILEY & SLOAN CO.,

860 BROADWAY, NEW YORK.

EASTER NOVELTIES,

✱

INCLUDING

ROSARIES AND CRUCIFIXES IN GOLD AND SILVER.

ALSO HAIR PINS, TIARAS AND A GENERAL LINE OF GOODS
FOR LADIES' WEAR.

F. & B.

LET THE FIGHT GO ON. The war between SEAMLESS and GOLD SOLDERED CHAINS will prove one of two things, either Seamless Wire is as good as Gold Soldered, or Gold Soldered is as good as Seamless.

A Dutchman offering a horse for sale was asked if the horse had the heaves. "I don't know," said the Dutchman, "but if de heaves are goot for de horse, de horse got 'em." If "Seamless" or "Gold Soldered" is good for chain, we've got 'em or can get 'em. We are making an honest, well finished chain of such good soldered wire that the seam cannot be found, and one that will wear ten years. The whole question is, who puts gold enough on their wire to make a good wearing chain? Some do and some do not. We make a finely finished chain of good, heavy, gold plated wire. Our chain will wear for ten years. We put our stamp on them which is a guarantee that the goods are right. The ten year chains.

Call for our Solderless Locket, made from stock that is as hard as it comes from the rolls, no solder used and the stock is hard and smooth.



THE WASHINGTON BRACELET.

Our "Washington Bracelet" is one of historic value. It shows a fine medallion of Washington, dates of his birth and death, dates of service as President, his seal, the original flag, his coat of arms and crest (from which was conceived our national flag), and the names of the thirteen original states.

We make a large line of Locket, Charms, Chains in Vests, Dickens and Victorias, Neck Chains, Bar Pins, Jersey Pins, Stick Pins, Initial Scarf Pins, Initial Bangles, Chain Mountings, Bracelets, Garters, Interlocking Glove Buttoners, Bead Necklaces and Earrings.

FOSTER & BAILEY,

PROVIDENCE, R. I.

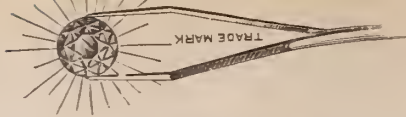

CHAS. S. PLATT.

1897. Successor to George W. Platt, 1891.

GOLD AND SILVER

Refiner, Assayer and Sweep Smelter.

Office and Refinery,

29 & 31 GOLD ST., near John St., NEW YORK.

Platers' and Electro-Platers' Silver, Platinum and Aluminum.

Workshops to let, with power. Fine Light—specialty for Jewelers. All Improvements. Apply as above.



S. P. HOWARD,
Gold and Silver Assayer,

Refiner and Sweep Smelter,

8 & 10 JOHN STREET, NEW YORK.

Smelting and Refining Works,

28, 30 & 32 Cumberland St., Brooklyn, N. Y.

Specialties: Sweepings, Gold, Silver and Platinum.

LOUIS NEWMAN, JR.

GOLD AND SILVER

Plater, Fire Gilder and Colorer.

Gilding by a New Process. Watch Cases, Jewelry and Novelties, Work stands acids, and in finish equal to Gold.

36 & 38 JOHN STREET, NEW YORK.

S. COTTLE & CO.,

MAKERS OF

FINE JEWELRY AND SILVER

NOVELTIES,

No. 860 Broadway, NEW YORK.

S. F. MYERS & CO., Wholesale Jewelers.

EVERYTHING
THAT
PERTAINS
TO THE
JEWELRY TRADE.
22
DEPARTMENTS.



WE REQUIRE
AND OCCUPY THE
LARGEST
SALESROOMS
IN OUR LINE.
4 STORES.
GROUND FLOOR.

48 & 50 Maiden Lane and 33 & 35 Liberty Street, New York.
CONSULT OUR MAMMOTH CATALOGUES.

L. LELONG & BRO.,

GOLD AND SILVER

Refiners, Assayers and Sweep Smelters,

SWEST CORNER HALSEY AND MARSHALL STREETS,

NEWARK, N. J.

SWEEPINGS A SPECIALTY.

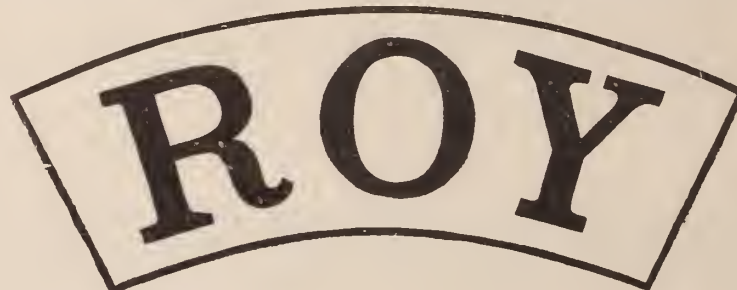

ODENHEIMER & ZIMMERN,

MANUFACTURERS OF

Gold and Diamond

JEWELRY,



THE O. & Z.
Interchangeable Initial Rings, Locketts and
SLEEVE-BUTTONS.



Gents' Seal,

Ladies' Fancy and

Children's Rings.

46 Maiden Lane, New York.

ALBERT LORSCH & CO.,

37 Maiden Lane, New York.

P. O. BOX 2139.

167 1/2 Broad St. (P. O. Box 941), Providence, R. I.

IMPORTERS OF

DIAMONDS, PRECIOUS AND IMITATION STONES.

Sole owners and Importers of

Unequaled in

The Sumatra Gem,
REG'D.

Brilliancy.

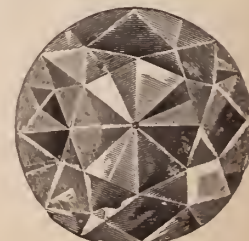
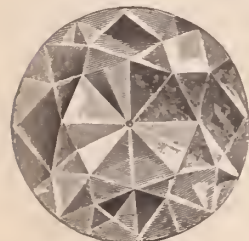

The nearest approach to the Genuine Diamond. For sale by all leading Manufacturers and Jobbers. * All Jewelry set with these Stones is sold on cards stamped "The Sumatra Gem, Reg'd."

L. & W. KAHN & CO., IMPORTERS OF DIAMONDS, 10 MAIDEN LANE, N. Y.

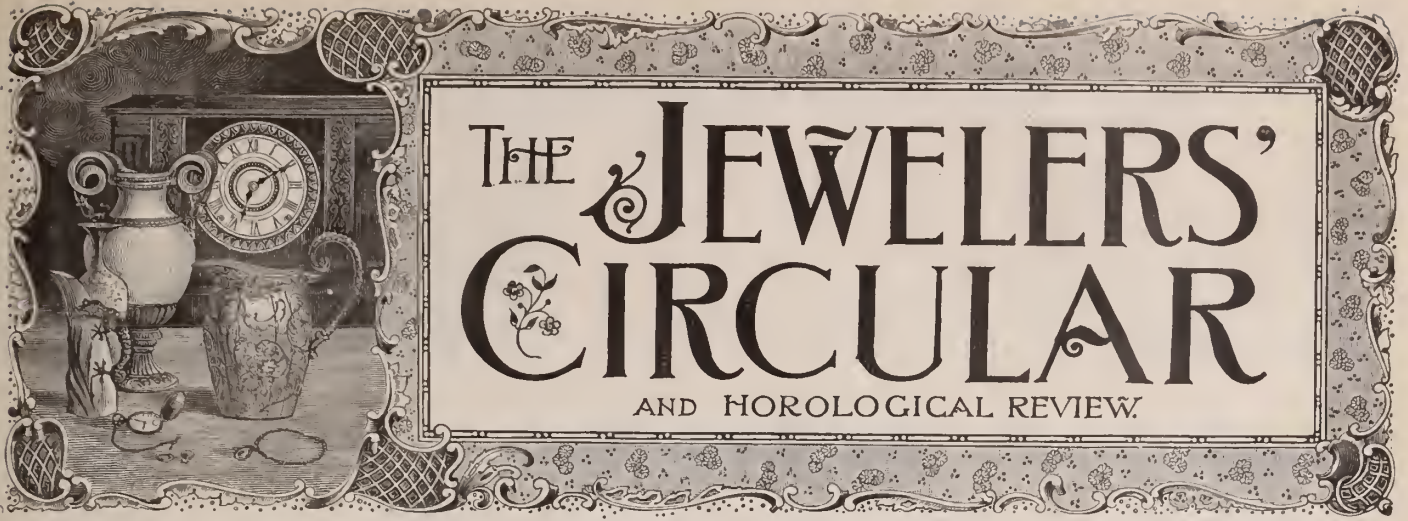

Entered at the Post Office in New York as second-class matter.

VOL. XXII.

NEW YORK, WEDNESDAY, MARCH 4, 1891.

No. 5.

MAIDEN LANE IN 1849.

THE illustration of the first eight buildings on the north side of Maiden Lane as they appeared forty years ago, which was published in the last issue of THE CIRCULAR, aroused considerable interest among the trade, and the reminiscent became very anecdotal. Many jewelers, whose memories of

trate the continuation of the block from where we left off—No. 11, to the corner of Nassau street.

At No. 13 Backus, Osborn & Co., furriers, hung out their shingle. They dealt in hats, caps and straw goods, and laid the foundation of the extensive business which is now

Co., also had either an office or store at this number. John P. Fellows, who will May 1 retire from business, is the present descendant of this firm. His office is still in the same building.

Vue J. Magnin & Guedin occupied the upper part of No. 19. This was an old and



by-gone days were awakened by the familiar names, and whose offices were at one time located in the buildings depicted, grew quite enthusiastic over THE CIRCULAR's enterprise in securing the print, and exhibited their appreciation by having the page containing the article framed and hung in their places of business. The picture is made doubly valuable by the fact that it will be but a short time before tall and imposing structures will replace the buildings which sheltered the pioneers of the American jewelry trade.

This week we continue the article and illus-

enjoyed by their successors on upper Broadway.

Next door, No. 15, J. Cox was located. He is said to have fitted up with gas fixtures, etc., more jewelry establishments than any other old time manufacturer of that class of ware. R. C. Bouton, a tailor, had rooms in this building.

Melville & Co. were the principal occupants of the next building, No 17. This firm subsequently became Melville, Tomes & Co., and later, Tomes & Co. Fellows, Wadsworth & Co., the predecessors of Fellows &

respected firm, both Mr. Magnin and Mr. Guedin being descendants of a long line of Geneva (Switzerland) jewelers. They subsequently moved to 2 Maiden Lane and later to 652 Broadway. Their last place of business was located at the corner of Sixteenth street and Union Square. Mr. Guedin died very suddenly one morning as he was about to enter his store, and the firm shortly after went out of business. Young, Redfield & Leavitt were established in the store as shown in the cut. The firm dealt in guns and cutlery; but at a later date Hiram

FIGURES TALK.

6,000 PAIRS DAILY of Spectacles and Eye Glasses are sent out by the

SPENCER OPTICAL MFG. CO.

MAKING A GRAND TOTAL OF

1,800,000 PAIRS ANNUALLY.

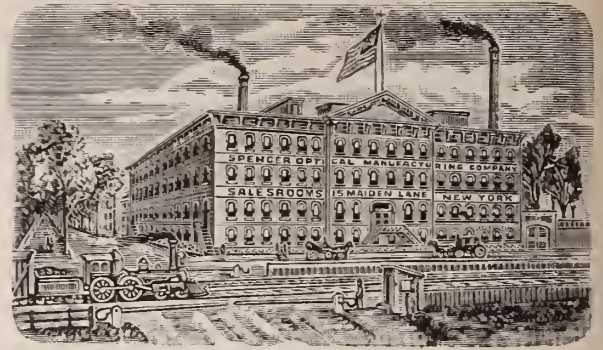

The reason is that the trade are realizing that it is to their advantage to deal directly with the manufacturers. We advertise no cut prices. All our prices are lower or as low as the lowest, when quality is considered. Our Catalogues and Price-List are free.

OPERA GLASSES

Of new designs and styles are already being prepared for the fall trade of 1891. Send in your orders and have name engraved on eye-piece. Our

OPERA GLASS HOLDERS

Are a great success, and customers are sending holders of other makes to be exchanged for our improved "grip."

A HARD CASE

To excel is the "Audemair" Occulists' Trial Case. 15 styles at 15 prices; from \$36.00 to \$100.00. You should see it before purchasing.

ANYTHING PERTAINING TO VISION

Can be obtained of us.

THE SPENCER OPTICAL MFG. COMPANY,

15 MAIDEN LANE, N. Y.

MANUFACTURING OPTICIANS.

MULLER BRONZE CO.

Underhill & St. Marks Aves., BROOKLYN, N. Y.

MANUFACTURERS OF FINE

BRONZE ORNAMENTS FOR THE CLOCK AND JEWELRY TRADE.



HISTORY. No. 121.

ALL
FIRST CLASS JOBBERS
HANDLE THEM.

NEW CONCERN. NEW GOODS.



ARTIST. No. 112.

TRADE

SEAMLESS

MARK.

GOLD · FILLED · CHAINS.

ON ACCOUNT OF

THE great popularity of the chains made exclusively by us for the past three years, the air has been FILLED and the paper of the various Jewelers' Journals COVERED with the word "SEAMLESS" which has been and is our trade mark.

We never had such a boom in our business as we have had since our friends commenced to advertise our goods.

We have only a word to add, and that is we make and sell the

ORIGINAL AND GENUINE

SEAMLESS GOLD FILLED CHAINS.

In addition to the word SEAMLESS and for the protection of our customers we place upon each Chain a tag bearing the following trade-mark :



Which is affixed by authority of its owners, as a guarantee that the Chains are made from the Burdon Seamless Filled Wire.

<p>BOSTON OFFICE, 6 WINTER STREET, In charge of I. W. STELLE.</p>	<p>NEW YORK OFFICE, 17 Maiden Lane.</p>	<p>PACIFIC COAST AGENCY, WM. E. PETTES & CO., PHELAN BUILDING, SAN FRANCISCO, CAL.</p>
--	--	---

Address all communications to

KENT & STANLEY,
PROVIDENCE, R. I.

CROSS & BEGUELIN,

21 Maiden Lane, N. Y.

IMPORTERS OF

Watches, * *
Diamonds,
Watch Materials,
* Opera Glasses.

JOBBER'S OF ALL GRADES OF

AMERICAN WATCHES

Gold and Rolled Plated Jewelry.



Selection Packages sent on

Satisfactory Reference.

◁ SEND FOR PRICE LIST ▷

NOTICE.

The undersigned having purchased the interest of Mr. GEORGE OWEN in the firm of G. & S. OWEN & Co., have this day formed a new co-partnership under the firm name of SNOW & WESTCOTT, for the purpose of continuing the business heretofore carried on by the late firm of G. & S. OWEN & Co.

**JAMES P. SNOW,
CHARLES E. WESTCOTT.**

March 2, 1891.

Young branched out as a manufacturer of silver plated ware.

Louis S. Fellows & Schell were the jewelers at No. 21. Rob. Schell is now President of the Bank of the Metropolis. John E. Hyde & Sons, watch importers, were also tenants. This firm is now represented by Jonathan Hyde, one of the sons at No. 22, almost directly opposite the original offices. A. Mayor, watch importer, and William Brewster, manufacturer of toilet goods, were also established here. As shown in the cut, P. Schneider, cane manufacturer, occupied the basement, and for many years an enormous walking stick, topped with a man's head with a supernaturally big nose, was one of the landmarks of the Lane. Mr. Schneider is now located on the corner of John street and Broadway.

In the building No. 23, which in 1849 had been erected two years, Grinnell & Salisbury, J. N. Olcott, Victor Bishop, Palmer, Richardson & Co., occupied offices, and Sill & Thomson, later Sill & Pell occupied the store. Mr. Salisbury, the junior member of the first named firm, died in an uptown church of heart failure; the firm then became Grinnell & Sons. Victor Bishop, one of the most prominent men of his time in the trade, was an importer of diamonds, and did an extensive business. He was a jovial and hearty Frenchman whose appearance in an office was always hailed with pleasure. Palmer, Richardson & Co. are now represented by Enos Richardson & Co. in the same building.

At No. 25, A. & J. Ramsey, fancy goods, Smith, Darrow & Co. gold pen manufacturers, and Treadwell & Frost, hat dealers, were located,

D. Hodgman, rubber dealer, located in the next building, the last of the block, was a prominent business man of the Lane during those days.

No Signs of Swenson.

MONTREAL, P. Q., Feb. 26.—A meeting of the creditors and friends of Carl Swenson was held in the Court House this afternoon, to appoint a curator for his estate. Those who formed the council were J. T. Bolt, jeweler, James C. King, Philippe Vaudal, Alex. Dubord, C. C. Rouillard, George Eckstein and John C. Pingel. John Frederick Wolff, Swedish Consul, was appointed curator.

Swenson's safe was broken open yesterday by order of the Chief of Police, but no clue was obtained. It contained only \$140 in bills, and some of the more valuable goods. Swenson had the key of the safe in his pocket when he disappeared.

Swenson was well known by sight by almost everyone, but he had very few intimate friends, and these are wondering whether he was robbed and killed, committed suicide or fell into the canal and was drowned in an air hole, while on his way to visit a friend at Point St. Charles, or suddenly carried out a long-expressed intention of going to Sweden. Of these four theories the first is thought plausible, because he constantly wore two rings valued at eight hundred dollars, al-

though had the safe key been stolen the safe would probably have been rifled.

As to the suicide theory, most of his acquaintances think that he was not the kind of man to take his own life. As he was accustomed to take long, lonely walks, however, it is feared that while visiting a friend at Point St. Charles he may have fallen into the canal, which in the past has been the depository of the bodies of many well known people who mysteriously disappeared during the winter and autumn only to be found during the spring.

Swenson had lived in Montreal for twenty-one years, and in the shop on Craig street, near Bleury street, for the last fifteen years. He came from the environs of Stockholm, Sweden. Up till five years ago he was quite a swell in his way.

The missing man was about five feet eight in height, and though fifty-two years of age had not a gray hair. His moustache and hair were of sandy color, his eyes of a bluish gray, and his teeth very bad. He had some \$13,000 on deposit in the Bank of British North America. The missing man never had a photograph of himself taken.

A New Haven Jeweler Expires.

NEW HAVEN, Conn., Feb. 27.—Alonzo A. White died on Tuesday. He had found quite a large circle of friends here, although he came to the city only two years ago, and he had built up a successful business.

His store was the one where C. J. Monson & Son, who were for years among the leading jewelers in the city, were located. Mr. White, who was for many years a jewelry auctioneer, conducted auction sales at his store during evenings; in his branch store in Waterbury, Mr. Cummings conducted similar sales. A wife and an adopted daughter survive him.

The deceased's will was to-day probated. The will leaves goods in the New Haven and Waterbury stores to the widow, who will probably continue the former.

J. M. Donelson Again Heard From

ST. LOUIS, Mo., Feb. 25.—Detectives Alexander and Smith arrested Louis Betts yesterday morning on a telegram from the Chief of Police of Minneapolis. Betts was wanted in that city on a charge of larceny of several thousand dollars' worth of diamonds from the Donelson Jewelry Co. Several gems were found on his person.

Betts was employed in a store situated next door to the jewelry establishment. He knew Mr. Donelson well, and purchased several diamonds from him. Mr. Donelson used to send him diamond pins, and finally gave him diamonds to sell among his friends.

Betts said to the CIRCULAR representative that "My dealings with Donelson have been entirely honest. I knew him well. I should judge that the diamonds he loaned me to sell do not exceed in value \$400."

E. G. Capo, Florence, Ala., has gone out of business.

THE

PAIRPOINT MFG. CO.,
 New Bedford, Mass.

FINE
GOLD AND SILVER PLATED WARE.

OUR LARGE LINE
 OF
STAPLES
 AND
NOVELTIES

WILL BEAR INSPECTION.

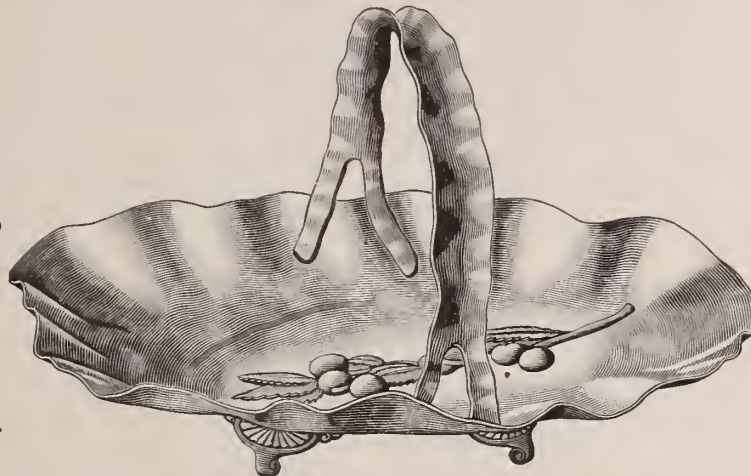

No. 1250. CAKE BASKET.

Quality
 Guaranteed.

NEW YORK.

CHICAGO.

SAN FRANCISCO.

FOR CLEANING AND POLISHING.

THE LATEST AND THE BEST
POLISH
 FOR
 SILVER GOLD, NICKEL
 AND GLASS.



WILL NOT SCRATCH
 THE
 FINEST SURFACE.

EVERY RETAILER OUGHT TO HAVE IT IN STOCK.

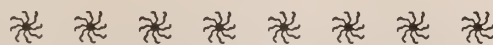

DAVID F. CONOVER & CO.

PHILADELPHIA, - - - - - PENN.

Boston.

D. C. Percival enjoyed a brief outing down on Cape Cod last week.

Harry F. Hayes, of Floyd, Pratt & Co., who has been on the sick list over a month, is about once more.

H. F. Coffin, with D. C. Percival, has returned from a holiday outing at his old home in Peterboro, N. H.

Washington's birthday was a holiday in the trade here. Dean Southworth, of D. C. Percival & Co., gave a reception on the evening of Washington's Birthday at his residence.

J. H. Hale, watchmaker for Henry Cowan, has taken new quarters at 339 Washington street, the space he occupied being needed by Mr. Cowan to meet the demand for increased room.

E. A. Whitney and Harry Pitcher, one of his salesmen, have brought back a fine collection of fish stories from Stoddard, N. H., where Mr. Whitney has been enjoying his first vacation in eight years.

Ed. Simons, of Simons, Bro. & Co., Philadelphia, was on a farewell tour in this locality last week. Hereafter he will look after the New York trade, and Mr. Rhodes will succeed him as the firm's representative in this section.

The New England members of the National Association of Jobbers in American watches met yesterday afternoon at the Parker House, at three o'clock, to receive

the report of their committee on membership and to elect officers for the year.

Among the salesmen who were in town last week were: Charles Power, of Randel, Baremore & Billings, B. S. Samuels, of the L. A. Cuppa Mfg. Co., Manasseh Levy, of Kahn & Levy, New York, Mr. Miller, of Shoemaker, Pickering & Co., Newark; E. W. Martin, Providence; John C. Perry, of the Aurooa Watch Company; B. S. Freeman, of Attleboro Falls.

Henry Cowan's employees evidently believe that marriage is not a failure. Following the announcement of salesman W. P. Hitchcock's intended marriage on the 5th inst. comes that of the engagement of Miss G. F. Murch, the head book-keeper, while salesman W. H. Everton is soon to become a Benedict.

Putman & Wallen, who succeeded C. W. Baldwin two years ago, are retiring from business, and commenced last Thursday a closing out action sale of their stock.

Fire Devastates Two Jewelry Stores.

EDINA, Mo., Feb. 25.—A disastrous fire, which destroyed nearly the entire business part of this town, occurred early this morning. The total loss is about \$100,000 and the insurance \$50,000. The fire started in a frame building occupied by jeweler J. W. Bryant. Thence the fire spread to the adjoining buildings, and finally enveloped the entire block. J. L. Yon, jewelry and dry and fancy goods, was also burnt out; loss, \$25,000; insurance \$27,000.

The Penalty of Plating Nickels.

BOSTON, Mass., Feb. 26.—Yesterday a Cambridge jeweler in good standing, whose name is withheld from the press by the Court, was placed under arrest, charged with violating the United States laws relating to counterfeiting by gold-plating five-cent pieces with a ring soldered on to them to be used as watch charms. The law provides a fine of \$100 for each coin thus plated, and does not require guilty intent to procure conviction, it being expressly stated that no plating of any sort can be done.

The United States secret service officers who arrested the jeweler, declare that many dealers in Boston and vicinity have been plating nickels for customers, despite the fact that a previous case resulting in conviction and heavy penalty was conspicuously on record.

The defendant was held by United States Commissioner Hallett, before whom he was taken, in the sum of \$200 to await the next session of the United States District Court.

Indianapolis.

W. T. Marcy is in Chicago.

The building in which Horace A. Comstock's store is located, is to be torn down.

Elliott Sims, of Sims & Heaton, who have retired from business, has entered the employ of Nichols, Pee & Co.

John Gardner, son of Thos. W. Gardner, has left the bench and has gone on the road

The R. Wallace & Sons Mfg. Co.,



No. 230 CUP. IN STERLING SILVER, TWO-THIRDS SIZE.

MANUFACTURERS OF

Sterling Silver, Plated Ware & Fine Cutlery

FACTORIES, WALLINGFORD, CONN.

{ New York Store: 3 Park Place.
Chicago Store: 104 State Street.

for Nichols, Pee & Co. O. T. Wilson has returned from his maiden trip for the same house.

The Sandbag Was Not A Success.

STAMFORD, Conn., Feb. 28.—There was a daring attempt at robbery here this afternoon, which has excited the entire community. At about three o'clock two strange men entered Augustus Knowholtz's jewelry store on Pacific street, an important business thoroughfare, and asked to see some watches. As some silver watches shown did not suit them Mr. Knowholtz produced several gold timepieces.

As he placed them on the showcase one of the men asked the other for money. The latter put his hand in his pocket, apparently to get his pocket-book. A moment later the jeweler was stunned by a blow on the head, and his eyes were filled with sand. He quickly drew the watches toward him, and they fell to the floor. He then shouted for help, and the assailants fled. They were overtaken by a pursuing crowd and locked up. They gave their names as John York and Patrick McLaughlin.

The sand-bag was made of a sausage case filled with ordinary building sand. But for the blow breaking the bag Mr. Knowholtz would have been knocked senseless, and his store undoubtedly plundered.

Auctioneer Cummings Acquitted.

NEW HAVEN, Conn., Feb. 27.—The case against Frank G. Cummings, manager of the Waterbury store of the late A. D. White, of New Haven, was this week decided. The case had aroused much interest among the jewelers and the general public of that city.

Cummings, who, as stated in the last issue of THE CIRCULAR officiated as auctioneer at evening sales of goods held at the store, was charged with procuring money under false pretences by selling plated watches for solid gold. The court found the accused not guilty and discharged him. Judge Cowell's opinion was that a person who expects to buy a solid gold watch for \$21 even at auction should seek redress by civil process, if any.

The Lancaster Watch Factory to be Auctioned Off.

LANCASTER, Pa., Feb. 28.—D. Ramsay Patterson, assignee of the Lancaster Watch Company of this city, was here on Friday consulting with his counsel, H. B. Swarr, regarding the best mode of procedure for disposing of the property of the company. Owing to objections by certain creditors it was decided not to ask the court for an order of sale but to offer the property as a whole at assignee's sale early in April.

The assignee who has realized \$33,000 from the stock of the company since the assignment, places the remaining assets at considerably over \$100,000. Three different parties are now making inquiries with a view to purchasing, and in event of either securing the works they would again be operated as a watch factory.

ESTABLISHED 50 YEARS.

LANDEL, BAREMORE & BILLINGS,

IMPORTERS OF

DIAMONDS,

AND OTHER PRECIOUS STONES.

FINE PEARLS A SPECIALTY.

MANUFACTURERS OF

DIAMOND JEWELRY,

IN THE LATEST DESIGNS.

Diamonds Recut in Modern Styles or Repaired on Premises.

58 Nassau Street,
29 Maiden Lane,
NEW YORK.

1 Tulp Straat,
AMSTERDAM.

1 St. Andrews St.,
Holborn Circus,
LONDON, E. C.

LARTER, ELCOX & CO.

MANUFACTURERS OF

THE SPRING BACK STUD.



Send for Selection Package of Studs.

—
SNAKE RINGS.

GENTLEMEN'S

WHITE · ONYX · JEWELRY.

—
LADIES' RINGS.

—
Gentlemen's Rings.

FACTORY, NEWARK, N. J. + + OFFICE, 41 & 43 MAIDEN LANE, N. Y.

ORIGINAL

GOOD FRIDAY NOVELTIES,

IN
STERLING SILVER.

FRANK H. LA PIERRE,

No. 18 EAST 14th STREET,

NEW YORK.

★ ROGERS & BRO. A-1.

OLDEST BRAND MADE.

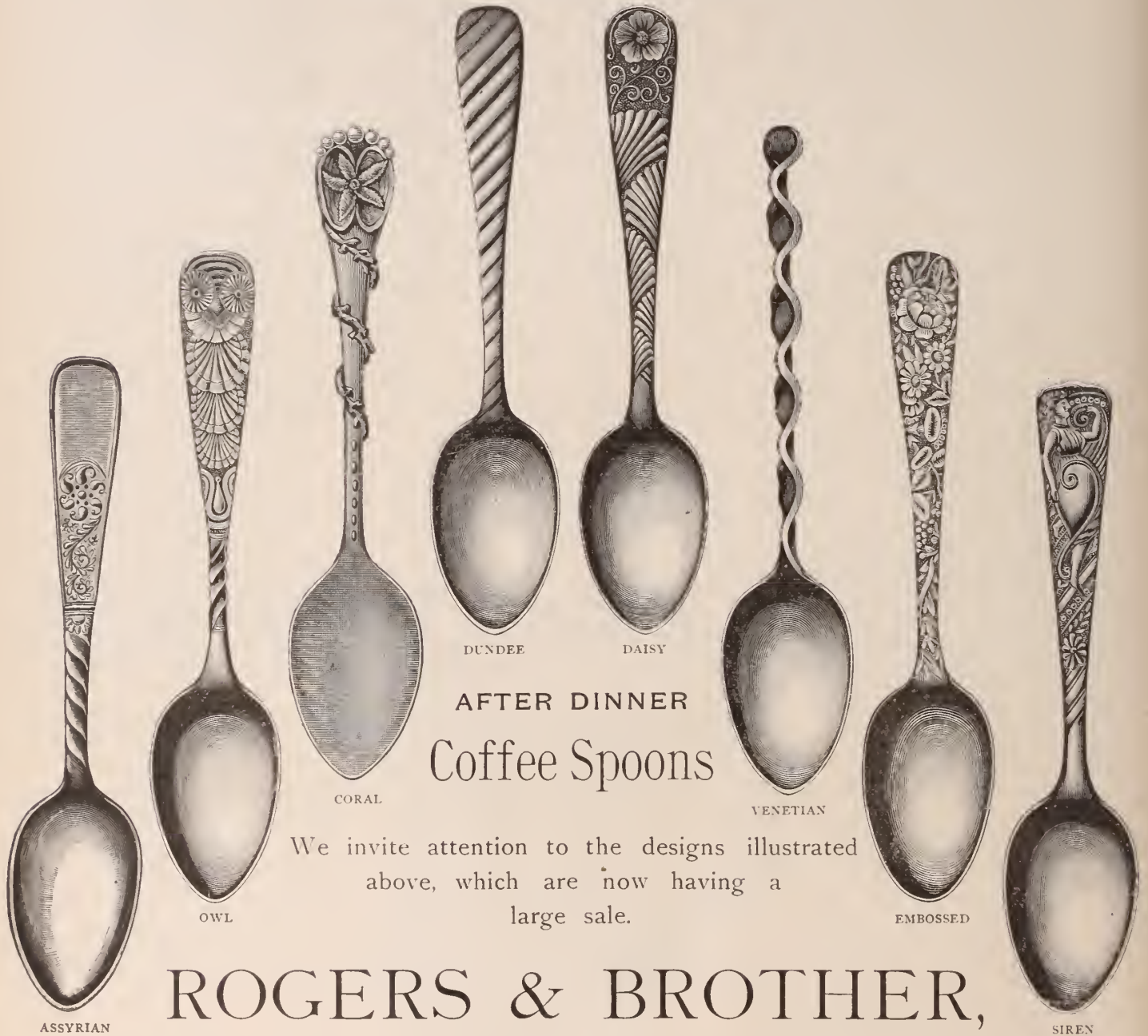

We invite attention to the designs illustrated above, which are now having a large sale.

ROGERS & BROTHER,

WATERBURY, CONN.

MANUFACTURERS OF THE CELEBRATED

STAR BRAND GENUINE ROGERS' GOODS,

SHOW ROOMS, No. 16 CORTLANDT STREET, N. Y.

Photograph Albums and Price Lists furnished to the trade only, on application, accompanied by business card.

SWARTCHILD & CO.,

Our Complete Catalogue, illustrated, will be sent to any one forwarding us their address, free of charge.



We give special attention to mail orders. They are filled promptly the same day that they are received.

76 and 78 State Street, Chicago.

TO THE TRADE ONLY.

Balance Staffs, - 60 Cents.
 Inserting Pivots, 40 Cents.
ALL OTHER WORK IN PROPORTION.
 SEND FOR PRICE LIST.
THOMAS JUZEK & CO.,
 ELCIN, ILL.

WOOD & HUGHES,
 Sterling Silverware Manufacturers.
 New York Agents for the Derby Silver Co.'s
FINE QUADRUPLED PLATED WARE.
 No. 16 JOHN STREET, - NEW YORK.
 206 Kearney St., San Francisco, Cal.
 HASKELL & MUEGGE, Agents.

The "BRYANT" Initial Ring.

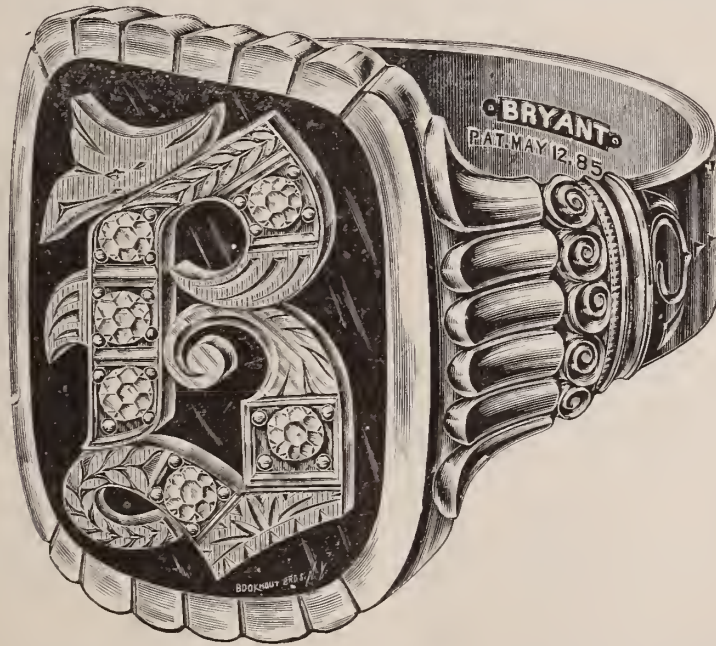

In Various Styles, Most Easily Interchangeable,
 Handsomest and Best.

M. B. BRYANT & CO.,

10 MAIDEN LANE, - - - NEW YORK.

Exit the Name of G. & S. Owen.

ON Monday the name of G. & S. Owen & Co., which for fifty-six years had been prominently before the trade, was discontinued. On that day James P. Snow and Charles E. Westcott, the junior members of the firm, bought out the interest of George Owen, and formed a new partnership under the firm name of Snow & Westcott, for the purpose of continuing the business.

The house of G. & S. Owen & Co. was founded in June 23, 1834, by Smith and George Owen and Alexander Hunter, the firm name being Hunter, Owen & Co. Their first shop was located in the attic of a building on Steeple street, Providence, R. I. At the end of six months Mr. Hunter retired from the firm, the brothers continuing the business under the style of G. & S. Owen. Between that time and 1856, this factory was located at various places. In the latter year, they moved to the second floor of the Mathewson & Allen Building, where they remained 17 years. In 1873 they occupied the fourth floor of the six-story building at the corner of Snow and Chapel streets, which they had erected for jewelry shops, and in which the factory is still located.

The style of G. & S. Owen remained unchanged until 1858, when other partners were admitted, and the name became G. & S. Owen & Co. In 1872 James P. Snow was admitted into the firm, and has since had entire charge of the business in New York, and in 1875 Charles E. Westcott became a partner and has had charge of the factory at Providence. The Owen brothers, since the entrance of these gentlemen, took no active part in the business. On April 17 Smith Owen died at the age of 80 years. George Owen is now in his 86th year.

The members of the reconstructed firm are in the prime of life, and will maintain the high esteem in which the old firm, in a measure due to their own efforts, was held by the trade.

Production of Precious Metals of 1890.

WASHINGTON, D. C., Feb. 28.—There are many interesting facts in the report of Edward O. Leech, director of the mint, on the production of the precious metals for the calendar year 1890, which has just been submitted to Congress. The report shows that the gold product of the United States was 1,588,880 fine ounces (troy), of the value of \$32,845,000, an increase of \$45,000 over the product of the preceding year.

The total value of the gold deposited at the mints during the year was \$56,217,105, of which \$31,234,342 was domestic bullion, \$4,352,422 foreign gold bullion, \$8,857,447 foreign gold coin, \$558,386 light weight domestic gold coins, \$3,765,364 old jewelry, plate, etc., and \$7,449,141 re-deposits.

The total gold imports were \$20,379,456; exports, \$24,095,168, a net loss of \$3,715,712. The total silver imports aggregated \$30,782,531; exports, \$26,614,003, a gain of silver of \$4,168,528.

JEANNOT & SHIEBLER

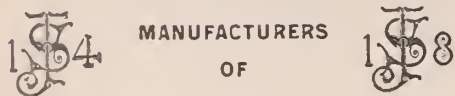

MANUFACTURERS
OF

Fine Gold Watch Cases.

No. 20 MAIDEN LANE,

New York.

Constantly on hand, 14k. and 18k. Cases
to fit any Movements in the Market.

**GEO. W. SHIEBLER,
SILVERSMITH.**



Artistic Novelties.

HOLLOW AND FLAT WARE.

Sterling Silver

No. 8 Liberty Place,

NEW YORK.

The amount of precious metals used in the arts (jewelry, etc.) in the United States during the calendar year was: Gold, \$18,105,901; silver, \$9,231,178. The metallic stock of the United States was, approximately, on January 1, 1891: Gold, \$704,597,128; silver, \$486,545,076; total, \$1,191,142,204.

American Association of Opticians.

THE third semi-monthly meeting of the American Association of Opticians was held at 8 o'clock last Wednesday night. Frank Levison, of New Rochelle, N. Y., was in the chair. In opening the meeting Mr. Levison made a few remarks in which he said that he felt confident of the success of an organization of the character of the Association, and that its influence in elevating the profession of optics was far-reaching. Secretary Rosenblatt then read the minutes of the last meeting, at which the following Constitution and By-laws were adopted:

CONSTITUTION.

ARTICLE I.

This Association shall be known as the AMERICAN ASSOCIATION OF OPTICIANS.

ARTICLE II.

The objects of this Association are the promotion of fraternal intercourse, mutual advantage, and the elevation and protection of the optical profession.

ARTICLE III.

The business of this Association shall be transacted by the officers and a Board of Directors, consisting of President, Vice-president, Secretary, Assistant Secretary, Treasurer and a Board of three Directors.

ARTICLE IV.

Any person is eligible as a member of this Association who can furnish a certificate from some recognized optical school or instructor or who is able to pass a satisfactory examination before the Board of Directors.

ARTICLE V.—DUTIES OF OFFICERS.

PRESIDENT.

SECTION 1.—It shall be the duty of the President to preside at all meetings of the Association, sign all orders and documents drawn by the Secretary on order of the Association, appoint all Committees, cast the deciding vote on all questions, perform such duties as the Association may direct, and present a written report at the annual meetings.

VICE-PRESIDENT.

SECTION 2.—In the absence of the President the Vice-President shall perform the duties of his office.

TREASURER.

SECTION 3.—It shall be the duty of the Treasurer to receive all moneys from the Secretary giving his receipt therefor; he shall pay all orders drawn upon him by the Secretary, signed by the President and shall keep an account of all moneys received and expended, and present a full written report at the Annual Meetings; he shall be allowed to carry funds not exceeding \$100; any surplus above that amount shall be paid over to the Directors for investment; he shall furnish a bond to the amount of \$200.

SECRETARY.

SECTION 4.—It shall be the duty of the Secretary to keep a full account of the Minutes of the Association, also of the Board of Directors, attest all orders and documents, keep a correct account between the Association, and its members, perform such other duties as may be required of him, and present a written report at the Annual Meeting, and affix the official seal to all documents.

WE DESIRE to call your attention to our large and varied assortment of

Complicated, High Grade Gentlemen's and Ladies'



In Gold Cases, both Plain and Enameled, in Choice Designs.

THE LARGEST STOCK EVER SHOWN IN THIS COUNTRY.

NON-MAGNETIC WATCH CO.

OF AMERICA

CHAS. McCULLOH, RECEIVER,

177 Broadway. - - - NEW YORK.

Essex Watch Case

COMPANY,

T. B. HAGSTOZ, President.

TRADE MARK



6 Maiden Lane, N. Y.

OFFICE.

NEWARK, N. J.

FACTORY.

GOLD FILLED CASES.

ASSISTANT SECRETARY.

SECTION 5.—The Assistant Secretary shall perform all the various duties of the Secretary, taking his place during his absence and assist the Secretary at all times.

BOARD OF DIRECTORS.

SECTION 6.—It is the duty of the Board of Directors to meet every two weeks and perform such executive business as they may deem a benefit to the Association. Any vacancy in the Board of Directors shall be filled by a majority vote of the members present at a quorum meeting. It shall be the duty of the Secretary to notify members when a vacancy for officers of the Board of Directors is to be filled.

ARTICLE IV.
MEMBERSHIP.

SECTION 1.—Membership may be acquired only by legitimate opticians, who, after application in writing to the Secretary, shall be voted upon by the Association and a majority vote shall elect; applicant when elected shall sign the Constitution and By-laws.

SECTION 2.—Applications for membership shall be acted upon within one month after date of application, to be preceded by a report of the examining committee. Applicants must be balloted for separately.

ARTICLE V.
FEES.

SECTION 1.—The fees must accompany each application for membership; should applicant be rejected his fee shall be returned by the Secretary.

SECTION 2.—The fee for membership shall be \$2.00 dues \$3.00 annually, said dues payable semi-annually, in advance, which shall include one year's subscription to the official organ.

ARTICLE VI.
FINES AND EXPELSIONS.

SECTION 1.—Any member guilty of unprofessional conduct, violating the laws of the Association, or who shall persist in neglecting any duties that may be imposed on him by the Association, may be fined, suspended or expelled by a two-third vote of members present at a regular meeting; it is provided that no member be expelled before his case has been presented to a Grievance Committee, who shall inform him of the charges made against him, and be given an opportunity to be heard in his own behalf. Said Grievance Committee to report the result of their inquiries to the Association for action at the next regular meeting.

ARTICLE VII.
SUSPENSIONS.

SECTION 1.—Any member of the Association owing six months' dues shall be notified of said indebtedness by the Secretary; if not paid at the next regular meeting following said notification, his name shall be stricken from the roll and deprived of all privileges.

SECTION 2.—Any member suspended for non-payment of dues may be reinstated by paying the full amount of the indebtedness against him—by a majority vote of the Association at the next regular meeting succeeding application for reinstatement.

USE THE  **AMERICAN MAINSPRINGS**
FOR ALL KINDS OF AMERICAN WATCHES.
[FACSIMILE OF WRAPPER.]

1 DOZ. MAINSPRINGS
18 S. E. O. S. 
Extra Quality.
TRADE  MARK.

THE BEST IN THE MARKET.

L. H. KELLER & CO.,
Dealers in Fine Watch Materials and Tools.
AGENTS FOR THE PATEK, PHILIPPE & CO. WATCHES.
64 NASSAU STREET, NEW YORK.

GENTLEMEN:—I think the trade this Spring will be better than last, and, although I can turn out double the work I did then, you had better be on hand with your orders, for I expect that my sales will be very large—equal to last Fall, if not double. You see the field is constantly widening and the demand is increasing, and why? Did you ever stop to think that there are 65,000,000 people in the United States, and the per cent. of this number that use glasses is one-fifth, or 20%, making 13,000,000 people wearing eyeglasses, and if you count the myriads in Europe and South America, why it is simply immense, and it needs cultivation. Why! Gentlemen, we ought to be able to double our business every year for the next ten years.

Yours respectfully,
Springfield, Mass. S. F. MERRITT.

The Highest Grade
— OF —
Electro Silver
Plated Ware



Is Stamped with the
ROGERS TRADE-MARKS.

MANUFACTURED BY
The Wm. Rogers Manufacturing Co.,
P. O. DRAWER 30,
HARTFORD, - CONN

MATHEY BROS., MATHEZ & CO.

16 MAIDEN LANE, N. Y. AND BRASSUS, SWITZERLAND,
MANUFACTURERS AND IMPORTERS OF

Plain and Non-Magnetic Movements.

Complicated Watches a Specialty.

CHRONOGRAPHS,
MINUTE REPEATERS,
AND
SPLIT SECONDS,

IN ALL GRADES AND SIZES.

SOLE AGENTS FOR

H. L. Matile, C. H. Meylan and J. J. Badollet. Watches Demagnetized.



REPEATERS



CHRONOGRAPHS.

time she did use her eyes for near work, her occupation making it unnecessary for her to accommodate for near objects.

Dr. Stout then cited a case of compound hypermetropic astigmatism. A man, age 30, been wearing glasses for five years but have never suited him. Examination with ophthalmoscope showed 3.00 D. of hypermetropic astigmatism and 2.50 D. of hypermetropia, $V = \frac{20}{1000}$. Both eyes $a + 2.00 D^s = + 3.00 D^c$ ax. 90° over each eye. Vision = $\frac{20}{200}$ minus. He had been wearing cylindrics only, which corrected the astigmatism and left the hypermetropia uncorrected.

Mr. Levison then brought before the members the case of a man age 32, $V = \frac{20}{1000}$ in both eyes; held paper over one side to see print clearly. Ophthalmoscope showed hypermetropic astigmatism, + 6, D. eye ax. 90° over both eyes $V = \frac{20}{200}$.

Fighting for Optician Gall's Money.

THE estate valued at \$300,000 left by Joseph Gall, the old Union Square optician who died some years ago, was the subject of a suit tried before Judge Patterson in the New York Supreme Court last Wednesday.

Until recently the contest for the possession of the estate was in the Surrogate's Court, where Charles F. Gall, a nephew of the deceased, claimed it under Mr. Gall's will, made in his favor. It was finally adjudged, however, that the deceased optician left a widow in the person of his former housekeeper and

one child, and as the marriage had taken place subsequent to the execution of the will, that they were entitled to the property, and a decree to that effect was entered. Now Charles F. Gall demands the property under an alleged verbal contract made between his uncle and himself in 1883, some three years prior to the latter's death.

Mr. Gall claims that it was agreed between them that if he should change his surname to Gall, the name then being Charles Funkenstein, and go into business with Gall and keep up the business, the latter would make him his heir and leave him his entire estate. Decision was reserved.

Hymen at Delmonico's.

On the evening of February 24th the beauty of Delmonico's Louis Quatorze banquet hall was enhanced by the profuse decoration of flowers and silverware. The spacious salon was filled with a handsome and fashionably-dressed assemblage, numbering about two hundred and fifty persons.

The occasion was the wedding of Miss Frances Oppenheimer, daughter of Seligman Oppenheimer of Oppenheimer Bros. & Veith, to Edwin L. Meyers. The ceremonies began at 6.30 o'clock, Prof. Felix Adler officiating. A banquet in the boniface's best style followed. Among the guests present were many prominent people of the city, among whom were a number of representatives of the jewelry trade.

George A. Remington's Death.

THE death of George A. Remington on Tuesday of last week was a complete surprise to the trade. It was known that he had been for some time a sufferer from Bright's disease, but no serious results were anticipated.

The deceased for over eighteen years was buyer and superintendent of the stores of Benj. F. Spink, in New York, Brooklyn and Baltimore, and had an extensive acquaintance among the trade. He was born in 1832, at Barrington, R. I., and at an early age started in business in Providence. He was one of the victims of the financial panic of 1873, and the next year entered the employ of Mr. Spink.

A widow and son survive him.

Kansas City.

M. B. Wright & Co. will remove about April 1 to a store nearer the centre of the retail trade, at the corner of Eleventh and Main streets.

Bart McClune, who made an assignment two weeks ago to M. M. Allen, has satisfactorily liquidated his debts, which amounted to \$2,500, and has reopened his place of business, under his wife's name, I. L. McClune.

George Hosier, who has been with Cady & Olmstead for several years, left their employ on Feb. 23, to take charge of his large ranch in Texas. E. U. Hosier, who is manager for Cady & Olmstead, remains.

IMPORTANT NOTICE.

The New Trenton Movement.
H.T.G and O. F. S. W.



(OPEN PLATE.)



(CLOSED PLATE.)

We beg to notify the trade that we have placed on the market a NEW MODEL

18-Size, Seven Jeweled, S. W. Nickel Movement,

SURPASSING ANYTHING YET MADE FOR THE PRICE, and to which we invite your attention. These movements possess several new features which offer special advantages to watchmakers. They are Quick Train, Straight Line Lever Escapement, and have Safety Centre Pinions and hard enamel Dials. The barrel can be removed without disturbing the train or stem-winding parts. They are beautifully damaskeened, well finished and attractive in appearance and are EXCELLENT TIMEKEEPERS. EVERY MOVEMENT FULLY WARRANTED.

The Best Low Priced Movement in the Market.

FOR SALE BY THE JOBBING TRADE.

Send to your jobber for a sample movement. If he does not keep them, write us and we will furnish you the names of jobbers who do.

TRENTON WATCH CO., Trenton, N. J.

Ludwig Nissen
John J. ...
Alex. ...

18 JOHN ST. NEW YORK.

MOORE & HORTON,
MANUFACTURERS OF
SOLID GOLD JEWELRY,
No. 11 Maiden Lane, New York.
Fine Imitation Diamond Goods a Specialty.
Selection Packages sent on Application.

ALVIN MFG. CO.,
Silversmiths,

860 Broadway, New York,
206 Kearney St., San Francisco.



DESIGN—OYSTER SHELL—SALT.

MADE IN LARGER SIZES FOR ASH TRAYS, &c.

Design Patented.

ALEX. WIEDERHOLD,
20 MAIDEN LANE N Y.,
REPAIRING JEWELER.

Jobbing sent to me by mail or express will be repaired and returned promptly. Prices Moderate and First-class Workmanship Guaranteed.

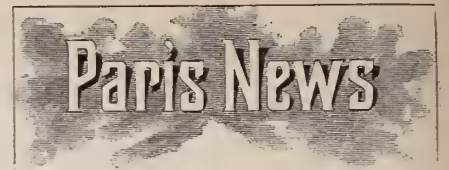

PARIS, Feb. 21.

The Paris Carnival has been a little more animated than usual this year, and jewelers who made in advance fancy articles, answering the wants of that frolicsome time, have done a good business. Cheap enamelled jewelry in that line has sold well. I saw at a masquerade ball a pretty girl in a Columbine costume, with black cats as earrings, and as a necklace a succession of enamelled busts of punchinellos and harlequins strung together, with a moonstone headed figure of *pierrat* hung by the neck as a pendant.

In fancy balls at Paris and at Nice ladies wear the most eccentric jewelry. Repulsive animals made of diamonds, rubies, emeralds and sapphires seem to creep or run over their extravagant costumes. A goddess of night in black velvet dress studded with pale yellow stars was adorned with a string of diamond mice, apparently running across her skirt from the waist down. On her head stood a diamond owl with topazes for eyes. A fancy queen of the ocean, whose skirt imitated sea-weeds, wore on each side of her waist a craw-fish made of alternate lines of rubies and brilliants. She had a star-fish as a brooch, hippocamps gracefully curled like an interrogative dot instead of earrings, and on her head was a large shell standing on edge, with weeds spreading on both sides, and a splendid diadem made of emeralds and diamonds, with a pink pearl near the base.

From time to time some people assert without any evident reason, that earrings are out of fashion and jewelry is almost abandoned. At the present moment these enemies of ours would find it very difficult to obtain credit for their malevolent statements. Ladies thoroughly understand that they cannot do without jewels, and even those who are happy enough to possess the most valuable sets always find in the jewelry line, something which they ought to have. Diamonds and pearls still occupy the highest rank in their estimation, but they think that rubies, emeralds, sapphires and turquoises are not to be disdained. They all envy, for instance, the magnificent sapphire, a perfect stone which is one centimeter in diameter, that Madame Mackay purchased from a Russian prince at the price of 750,000 frs. (\$150,000.)

Ball dresses are almost covered with precious stones. Even the long abandoned coral is found worthy of attention. I have seen at a recent dancing soiree an elegant black satin robe all embroidered with conventional floral ornaments introducing gold stalks and stems with gatherings of fruit stone shaped coral beads forming flowers. Branches of jewelry and favorite insects are worn on all parts of the corsage.

A PLAIN SOLID GOLD RING IS A SMALL ARTICLE—BUT WE
MUST HAVE 'EM—AND THE PLACE TO BUY THEM IS OF

HILDRETH MANUFACTURING COMPANY,

53 MAIDEN LANE, NEW YORK.

TO BE CONVINCED SEND FOR PRICE LIST.

OR SAMPLES ON APPROVAL.

KENDRICK & DAVIS,

LEBANON, N. H.

MANUFACTURERS OF THE

Standard Dust Proof Watch Key.



After this date all Keys of this Style will have number stamped on each Key.

FOR SALE BY THE TRADE.



Ludwig Nissen & Co., 18 John street, New York, have just imported a forty carat diamond, without flaws, perfect in cut, and of fine color for so large a stone.

Frank Mauser, of Frank Mauser & Co., silversmiths, 30 Union Square, New York, is at present on an extended trip through the South and West in the interest of the firm.

At T. B. Clark & Co.'s cut-glass show room 53 Park Place, New York, a very dainty little novelty is exhibited—a cordial set comprising a bottle and twelve tiny glasses, perfect in form and cut, and with side handles.

Ira Barrows, of H. F. Barrows & Co., left on Monday for a two weeks' trip through the West. In addition to the firm's regular line of chains, he is showing a large line of their *fleur de lis* Victorias, which are proving one of the most popular novelties in the market.

E. R. Stockwell, 19 John street, New York, is receiving inquiries constantly for badges, medals, trophies, class rings and pins, and all kinds of special order work. He has made a specialty of this kind of work for years and has facilities for its prompt and satisfactory execution.

The array of fine diamond jewelry at the establishment of Sig. Hirschberg, 78 Nassau street, New York, is remarkable for its beauty. The designs of the pendants, necklaces, brooches, lace pins, etc., are original and unusually attractive. The patterns disclose diamonds in cluster, and pearls, rubies, emeralds, etc., in combination with diamonds.

Tuck & Giannini, a new firm, both partners having formerly been with the Craighead & Kintz Manufacturing Company, have taken the New York agency of several prominent manufacturers of wrought iron and brass goods and fancy lamp shades, and have opened a sample room at No. 96 Church street, where a fine line of their specialties can be seen.

J. A. Flomerfelt & Co., 177 Broadway, New York, are the general selling agents for the new patent stud which possess the merits of practicability and novelty. They are the "Signal Eyelet" and the "Vox-all," and in them the objections to the spiral form of stud are entirely overcome. The jobbing trade should send for samples of these goods, as they will undoubtedly win speedy popularity.

The Hildreth Manufacturing Co., who recently moved their factory from Brooklyn, where they had been located since 1875, to 53 Maiden Lane, New York, have now increased capital and facilities to handle considerable more business than ever before. The company manufacture a complete line of plain solid gold rings, in all weights, sizes and de

OPPENHEIMER BROS. & VEITH,
 Diamonds, Watches and Jewelry,
 2 Tulp Straat, 35 Maiden Lane,
AMSTERDAM. **NEW YORK.**

We beg to inform the trade that we are still in a position to fill orders for

✂ **DUEBER HAMPDEN WATCHES** ✂

Of all grades, from stock purchased previous to the closing of the factories at Canton.

JOHN A. RILEY & SLOAN CO.,
 860 BROADWAY, NEW YORK.

EASTER NOVELTIES,

INCLUDING

ROSARIES AND CRUCIFIXES IN GOLD AND SILVER.

*ALSO HAIR PINS, TIARAS AND A GENERAL LINE OF GOODS
 FOR LADIES' WEAR.*

OSTBY & BARTON,

SOLID GOLD BAND, STONE
- - AND FANCY RINGS - -



✂ **ALSO A LARGE LINE OF EMBLEM RINGS.** ✂

WILLIAM B. DURGIN

Designer and Maker of Wares in

STERLING · SILVER

SPECIALTY OF

Plain and Fancy Flatware

CONCORD, N. H.

degrees of curvature. Every dealer should send for one of their price-lists, from which they will note that their prices are lower than other manufacturers.

Frank H. La Pierre, 18 East Fourteenth street, of "Shakespeare Bangle" fame, returned last week on the *Aurania*, after a two months' sojourn abroad. Mr. La Pierre is enthusiastic over the sights of the Old World, and as he is one of those whose enthusiasm is always productive of results, the trade will have the opportunity of sharing in the delights of this trip ere long, when his observations take tangible shape in the way of some startling novelties, the first of which, announced in this issue, are some articles appropriate to the Easter season, and designated as "Good Friday Novelties."

The new patent O. F. cases recently placed upon the market by the Brooklyn Watch Case Company have proved successful. The advantages which these cases possess are manifold. The back and centre are of one piece and solid, the hinged dust band within forming another case which fits flush and securely into them. The case is practically a double one. It affords protection to the movement from dust and jar to an equal, if not greater extent, than cases of that class; being more economically made, its price, of course, is lower. A movement which had been carried in one of these cases for three years as an experiment was when removed, entirely free from dust.

The art of porcelain-decorating is receiving a great impetus since the completion of the new decorating shop of the Mount Washington Glass Co., New Bedford, Mass. About eighty skilled artisans are now at work there on the well-known and delicate "Crown Milano" ware just placed upon the market. The shop is light and cheerful and the artisans are of a high grade of intelligence. The foreman in charge deserves great credit for his persistent efforts in the cause of American decorative art. He is the designer of the many popular patterns the company have introduced, and his skill and taste are generally acknowledged. The "Crown Milano," mentioned above, is the crowning, as it is the latest production of the factory. It is in the style of the Italian Renaissance, the delicate colors of the background forming a sharp contrast with the applied work in rich dark colors, gilt and jewel effects. One of the specialties of the factory are the dainty little tomato and egg salts and sugars known

OTTO GAS ENGINE WORKS

SCHLEICHER, SCHUMM & CO.

PHILADELPHIA.

CHICAGO.

20,000 SOLD.

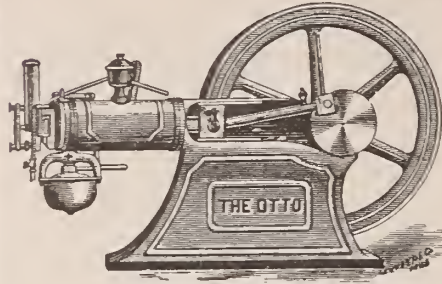

Guaranteed to consume 25 to 75 per cent. less Gas than ANY other Gas Engine doing the same work.

Our 1-horse power engine is largely used by Jewelers.

Price recently reduced to \$325 at Factory in Philadelphia.

Send for Circular and Reference List relating to this size.

JOHN SCHEIDIG & CO.

IMPORTERS AND MANUFACTURERS OF

OPTICAL



GOODS

43 MAIDEN LANE, NEW YORK.

A FULL line of Gold, Steel and Aluminum American Spectacles and Eye Glasses of latest and special designs. Imported and American Lenses. We also control the following brands of OPERA AND MARINE GLASSES; La Favorite, Colmont, Lemaire, College d'Optique.

SEND FOR ILLUSTRATED CATALOGUE.

LEMAIRE OPERA GLASSES.

E. R. STOCKWELL,

MANUFACTURER OF

BADGES AND MEDALS

IN GOLD AND SILVER,



FOR ALL SOCIETIES, INCLUDING

MASONIC
ODD FELLOWS,
GRAND ARMY.

Also for Schools.

BUTTON BADGES IN SILVER OR GOLD.

Enameling and Repairing for the trade.

19 John Street, N. Y.

THE LATEST PARISIAN NOVELTY



MANUFACTURED BY CROSSIN & TUCKER,

409 Pine Street, Providence, R. I.

to every jeweler in the country, and their assortment of colored lamps is as large and meritorious in design as can be found in the country.

Charles Magnus is continuing business at 18 John street, New York. He is offering the trade fine lines of diamonds and precious stones and mounted goods.

The "Tuxedo" pattern in flatware introduced some months ago by Rogers & Bro., has proved successful. The design which is handsome in all its details pleases all who see it.

For stone seal engraving and the engraving of arms, crests, etc., we can confidently recommend Wm. Park, of No. 26 John street, this city, who has long stood at the head of this branch of artistic work.

The regular excellent business with which Sexton Bros. & Washburn, 41 Maiden Lane, New York, are favored is in a measure due to the success of a number of specialties in fine mountings and devices which it will pay all dealers to examine.

The system of grading diamonds, originated and copyrighted by J. T. Scott & Co., 4 Maiden Lane, New York, has proved very effective, and the firm's customers are generally adopting it. The system has also procured them many new customers.

John B. Yates, 147 Nassau street, New York, is doing a large business in American watches. This line is his specialty. He is paying particular attention to United States watches, which are universally acknowledged to be excellent and reliable time-keepers.

The Geneva Optical Co., Chicago, the past week have had a most tasty window display. The dressing was a background of Nile-green plush on which daintily rested with "Negligé repose" an elaborate showing of opera glasses in aluminum and pearl. It is needless to say that the fair sex on their way to Marshall Field's went into ecstasy over the coveted "little gems" of the opera.

C. Dorfinger & Sons, cut glass manufacturers, 36 Murray street, New York, offer two new patterns, the "Belmont" and the "Dresden." Words are inadequate to describe the intricacies of the designs, but they both show the characteristic deep cutting for which the firm is justly celebrated. One of their latest achievements is a magnificent line of flower vases standing 17 inches in height and exhibiting the finest effects of the cutter's art.

The Waltham Watch Tool Company, of Springfield, is very busy on orders. The demand for the "Hopkin's" lathes and other tools of their make is constantly increasing, their 3x4 lathe meeting with an especially large sale. The "Hopkin's" lathe was among the first American lathes made, and the line of attachments that have been designed by the builders of these tools is very complete. The present company, which moved from Waltham to Springfield last August, have a very complete plant of special machinery for making lathes and other small fine tools.

KREMENTZ & Co.,
182 & 184 Broadway, NEW YORK

MANUFACTURERS OF

GOLD JEWELRY,

14-K. BEAD NECKLACES,

— AND —

KREMENTZ ONE-PIECE COLLAR BUTTONS.



A COMPLETE
LINE OF
Mounted
GOODS
Constantly
ON
HAND.

ARTIFICIAL EYES!

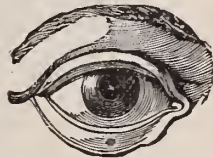

STOCK ORDERS OF
Selection Packages.

Largest Assortment.

GENEVA OPTICAL CO.,
23 Washington St., Chicago.



A Wonderful
TOOL
FOR THE BENCH.

Instantaneous in Its Work.

Dividing the inch into one thousand parts. A most practical tool for watchmakers for gauging from a hair-spring to a main-spring. Non-comparable for a height and depth gauge. Instantaneous for hair-spring work.

For sale by all
Jobbers.

NORDMAN BROTHERS,
120 Sutter St., SAN FRANCISCO, CAL.
Sole Agents for the United States.

ESTABLISHED 1837.

GEO. O. STREET & SONS,
MAKERS OF

Fine Rings, Locketts, Seals, Sleeve
Buttons and Links,

15 John Street, - NEW YORK.

WATCH DIALS.

Any kind watch dial duplicated within ten days. Factories supplied with dials for their entire production or with special designs for their high grade movements. Special rates for large quantities. Emblems, photographs, landscapes and ornamental work of every description on plain, enamel or under glaze.

WALTHAM DIAL CO.,
WALTHAM, MASS.

MAXHEIMER & BERESFORD,

MANUFACTURERS OF

FINE DIAMOND JEWELRY,

No. 3 Maiden Lane, New York.

ORDER WORK A SPECIALTY

TO WHOLESALE DEALERS.

WE HAVE FOR IMPORT
A FINE LINE OF

BLACK FOREST
(SCHWARZWALDER)

CUCKOO CLOCKS,

With Brass Movements in dust-proof cases.

E. R. SCHLENCKER, Manufacturer,
Schwenningen a/ Neckar,
WURTEMBERG, - - GERMANY.

Wm. Pfuger, traveler for Jos. Noterman & Co., Cincinnati, is expected home this week. He has sold a great many rings. Jos. Noterman & Co., being shrewd manufacturers, only need an inkling of a want to interpret it in the most taking style.

Jos. Jonas, Cincinnati, O., the well known designer, is holding up the reputation of his house by his seeming inexhaustible fund of original productions. He has given his attention lately to unique mountings for his firm's celebrated Ophir Diamonds. Jonas, Dorst & Co.'s travelers have a complete line of all the late patterns, which the trade would do well to look at.

One of the most successful jewelry auctioneers in the country is A. J. Comrie, 16 West 125th street, New York. He is not only thoroughly conversant with the jewelry business, having been a retail jeweler himself

for several years previous to embarking in his present vocation, but possesses undoubted talents as an auctioneer. He is in constant correspondence with leading jewelers in various parts of the country, who are anxious to secure his services, and any readers of THE CIRCULAR contemplating auction sales should communicate with him, kindly mentioning THE CIRCULAR in so doing.

A Window-Smasher Makes a Big Haul.

BIRMINGHAM, Ala., March 1.—A bold robbery was perpetrated at Rosentihl Bros.' store, under the Florence Hotel, on Saturday. In the show window was displayed a tray of diamond rings. A man was seen to approach the window from the sidewalk and gaze at them. He had a paper-covered bundle under

his arm, which he unwrapped and disclosed a large rock. This he hurled through the heavy plate glass, smashing it to pieces.

Then he seized the diamond rings, and thrusting them into his pocket, fled. John Rosentihl, one of the firm, sprang through the broken window in pursuit of the thief, but he was so badly cut by the glass that he had to be taken to a physician. No police were in the locality, and the robber escaped. The theft amounted to between \$3,000 and \$5,000.

To-day a man named G. W. Martin, alias Tom Long, was arrested charged with being implicated in the robbery. He offered to secure the jewelry for a reward and asserted that he had overheard a plot to rob the store. Persons who saw the robber, assert that Martin resembles him. All the jewelry has been recovered.



Revolve these rings in your mind, and you cannot help thinking of OSTBY & BARTON, the well known ring makers, 80 Clifford St., Prov., R. I

Sumner Bros.'s Offer of Settlement Rejected.

THE creditors of Sumner Bros., of Cleveland, O., held a meeting last Thursday in the rooms of the New York Jewelers' Association to hear the statement of Frank L. Sumner, the junior member of the firm. There were present representatives of creditors to the amount of \$70,000, among whom were Peter Zuecker, a Cleveland attorney, representing about \$43,000, the Manufacturing Jewelers' Board of Trade, about \$10,000, and the New York Jewelers' Board of Trade, about \$2,000.

In answer to direct questions, Mr. Sumner stated that he kept the books of the concern in single entry, and never took monthly trial balances. From his remarks it was gathered that there were three members of the firm, C. E. Sumner, Milton Sumner and himself. C. E. Sumner put in the capital and they all shared the profits, Milton and himself paying six per cent. interest to their brother for the use of his money. They began business in 1887, and took an inventory of stock in February, 1889, which showed merchandise and fixtures \$58,000, with book accounts and notes of \$45,000, making a total of \$103,000. The liabilities at the time were about \$65,000, leaving a surplus balance of \$38,900. Their net profits from 1887 to 1888 were \$15,000.

At the conclusion of Mr. Sumner's statement a motion was made to accept the offer of the firm, namely sixty per cent. in their own secured notes at three, six, nine and twelve months. The feeling of the creditors was apparent when it was found that there was only one vote in favor of this settlement.

It was suggested that there was a great necessity for removing the present assignee, and Mr. Zuecker, the representative of the Cleveland creditors, stated that he was in favor of the step proposed, but that he needed about \$10,000 more or a majority of the liabilities to be able to do so. The creditors present thought favorably of this and appointed David N. Smith, H. M. Condit, and P. T. Tunison, a committee to obtain the necessary claims.

It was subsequently ascertained that creditors representing about \$60,000 had consented to vote for the removal of the present assignee.

An Old Game Worked Successfully.

St. Louis, Mo., Feb. 27.—A neat, though old, confidence game was worked upon N. F. Schmidt, 722 Olive street, yesterday. At about 5 o'clock, p. m., a young man unknown to Mr. Schmidt, but of good appearance and evidently of German extraction, called at his store and asked to be shown some watches for ladies. A tray containing an assortment of such was laid upon the counter for his inspection. He selected one valued at \$63.00, and a watch worth \$62.00. He then asked to see some fob-chains and selected two, valued at \$18.00 and \$17.00 respectively. One pansy gold bracelet and

another enamelled, with small diamond setting, valued at \$24.00 and \$25.00 apiece, and two solitaire diamond rings worth \$150 completed the selection.

He ordered these sent to No. 1834 Lucas Place, stating that those articles which were not wanted would be sent back and the rest paid for. An errand boy was entrusted with the goods and told to accompany the gentleman. The man drove to 1834 Lucas place with the boy, and then took the articles from him, asking him to be seated in the parlor till he came down.

The cute young man did not return and has not since been seen. It was subsequently learned that he had but just engaged a room on Lucas street, and had left the house by a rear door. He is described as about 5 feet 7 inches in height, dark hair and complexion, and weighing about 140 pounds. He wore a brown overcoat and black stiff hat.

Receiver Wanted for Towne & Ingraham.

PROVIDENCE, R. I., Feb. 28.—The mere mention of the fact that the firm of Towne & Ingraham, 29 Point st., has dissolved, by the withdrawal of Eustace B. Ingraham, is not a very significant one until it is taken into consideration that Laurison Towne has applied to the Supreme Court to have a receiver appointed. The cause of this state of affairs is somewhat ambiguous, but nevertheless interesting.

The firm of Towne & Ingraham was formed about November 1, 1889, by Laurison Towne and Eustace B. Ingraham. It is stated that Mr. Ingraham was to furnish tools, machinery and \$5,000, in all equal to \$10,000, which sum Mr. Towne was to put in in cash. The latter, however, never furnished more than \$6,000 and a disagreement resulted.

Several months ago Mr. Ingraham went to New York, taking but little money with him; he drew a check on his house, to pay expenses. Mr. Ingraham later drew a check and sent it to the firm's bank. The bookkeeper of the bank returned it with the information that Mr. Towne had given orders that

Mr. Ingraham's name should not be honored. Mr. Ingraham immediately retaliated by giving a similar notice to the bank not to honor Mr. Towne's signature.

About a week ago Mr. Ingraham abruptly left the shop and has now started in business as agent at 127 Summer street leaving Mr. Towne to make a settlement with the creditors of the late firm, who owe between \$4,000 to \$5,000.

The Cincinnati Jewelers' Association Elect their Officers.

CINCINNATI, O., March 2.—The Cincinnati Jewelers' Association were in session Saturday, p. m., at the Burnet House, to elect officers. Aaron Herman was unanimously re-elected President; Joseph Homan, Vice-president, and Joseph Becker, Secretary and Treasurer. The new Board of Directors consists of C. Hellebush, Charles Ankeny, the new manager of the wholesale department at Duhme & Co., and Charles A. Nolting, of Oskamp, Nolting & Co. With these executives it is an undoubted certainty that all the undertakings of the organization will be a success.

The subject of a Board of Trade was discussed at some length, and a final motion of organization passed. There is material in Cincinnati for the proposed organization, and every effort to push the matter should be employed by the Association.

Since the re-organization, those not in the Association should be solicited to unite their interests with the combine for mutual benefit.

Edward Vanness' Sudden Death.

Edward Vanness, for many years established as a manufacturer of badges at 142 Fulton street, New York, shortly after three o'clock last Friday died suddenly while seated in the restaurant of "Sandy Spencer," at 212 Broadway. Mr. Vanness had been a sufferer from heart disease, and he was in the habit of taking a mixture of nitro-glycerine, alcohol and water. A daily paper erroneously stated that his death was due from an overdose of the medicine.

Our exceptional sale of Willson's Spectacles continues with increased activity. We are now shipping more spectacles daily than we shipped in a week, a year ago. The demand extends over the entire line, but is especially marked on the two numbers 184 and 155, which, owing to the advantages of an enormous purchase, we are able to sell at 20 per cent. below the regular prices. If you handle spectacles at all, we offer you in these two grades an inducement which is not likely to be soon duplicated and which you cannot afford to miss.

Bowman & Musser,

Importers and Jobbers,

Watches, Chains, Spectacles, Tools and Materials,

Lancaster, Pa.

Squabbling For the Assets.

CLEVELAND, O., Feb. 26.—The failure of the McBride & Marcellus Co., the announcement of which appeared in the last issue of THE CIRCULAR, may develop some sensational features. A lively fight for the assets of the company has been commenced between D. H. McBride and some of his relatives on one side and C. E. Marcellus and the receiver, O. J. Campbell, on the other.

Charles E. Marcellus has brought an action against the McBride & Marcellus company. The petition says that the McBride & Marcellus Co. is a corporation with a capital stock of \$50,000 divided into 500 shares of \$100 each, of which only 201 are subscribed for and issued. Marcellus owns sixty-two and one-half shares and is the secretary and a director. D. H. McBride has 112½ shares and is president and a director. L. W. Penfield is a cousin of McBride's wife, and owns twenty-five shares and is a director. R. C. Penfield is McBride's brother-in-law and owns one share and is a director. Edith McBride, the wife of D. H. McBride, is the other director. The establishment has its main office at 204 Superior street, with a branch office at 120 South Howard street, in Akron.

The company have been doing an extensive business in this and other States and have accrued liabilities of \$35,000, some of which is past due, and paper has gone to protest from lack of funds to meet obligations. If the assets are not wasted in litigation they will be sufficient to cover the liabilities. Creditors are pressing claims, and unless the courts interfere attachments will be levied on the stock. L. W. Penfield and F. A. Sciberling, of Akron, another brother-in-law of McBride, hold cognovit notes for about \$15,000 given April 10, 1890, and payable on demand and the claim is that this judgment note is secured by a mortgage on the stock.

The holders threaten to put the notes in judgment and take possession under them, which in the estimation of Mr. Marcellus would work irreparable injury to the creditors and to himself, as against McBride and his family relatives, inasmuch as the latter control a majority of the stock and are a majority in the board of directors. Marcellus alleges that they are conspiring together and threaten to remove or injure the assets by applying them to the payment of cognovit notes as preferences and to the exclusion of other creditors. He asserts in addition that it is proposed to also apply the assets to the payment of the firm's indebtedness of McBride & Marcellus, a partnership which preceded the corporation of the McBride & Marcellus Company, in the shape of obligations on which the Penfields are sureties and endorsers.

Early Monday morning J. W. Penfield put in judgment a cognovit note for \$9,673.93 (including costs). About three minutes after the levy and the appointment of the keeper, Receiver Campbell appeared and demanded possession but was refused.

Mr. Campbell has taken possession of the

branch store in Akron, and also the one on the west side this city.

Judge Hutchins, Mr. Campbell's law partner, says that the suit and the whole proceeding is merely Marcellus' effort that all creditors shall receive their just dues and that there shall be no preferences. Judge Hutchins also declares that the levy on the cognovit note judgment will do no good, as the receiver is the officer of the court and his possession dates from his appointment.

Sec. H. M. Condit of The N. Y. Jewelers' Board of Trade has a large number of claims on hand, on which he is working with great energy. He desires those creditors, who have not thus far presented their claims to do so at once, as a concerted action is to the interest of all concerned.

After the Kansas City Fire.

KANSAS CITY, Mo., Feb. 24.—The fire which destroyed the wholesale jewelry establishment of Herman Oppenheimer & Co., at 706 Main street, did not do as much damage as at first reported. The loss was only about \$15,000, covered by insurance to the amount of \$26,000.

The firm had the larger part of their stock placed in fire-proof vaults and they thus escaped a more serious loss.

Before the smoke had ceased to rise from the ruins, the firm had opened for business in a room adjoining their burnt-out store, and to-morrow they will remove back to their old quarters at 607 Delaware street. They moved to the building now destroyed on Jan. 1.

Had Confidence in His Legs.

WICHITA, Kan., March 1.—Charles Harker, representing a Chicago jewelry firm, while en route to the station this morning to catch an east-bound train, met Frank Lewing, a professional sprinter, whose acquaintance he had made in Denver. Harker had a valise in his hand containing nearly \$4,000 worth of jewelry, and mentioned the fact to his acquaintance.

Lewing watched his opportunity, and suddenly snatching Harker's valise, he sped down a byway and would doubtless have escaped with his booty had he not been met by an officer who, while unable to catch the thief, managed to make him drop the valise. Lewing is still at large.

Over the Border.

John Leslie, 62 Sparks street, Ottawa, is selling out with the intention of retiring from business.

T. J. Coughlin, head of the Jewelers' Hall, 14 King street, St. John, N. B., is about to move to another location on the same street.

We can confidently recommend Wm. Park, of 26 John street, New York, as the leading artist in stone seal engraving, and engraving on arms, crests, monograms, etc., in the highest style of the art.

The establishment of Chaloner & Mitchell, Strahroy, Ont., was last week burnt out; the loss sustained was \$4,500; insurance in the Mercantile Insurance Co., \$3,500. The cause of the fire is unknown.

Justice Meredith gave judgment at Toronto last week to discharge W. F. Ross from custody. Ross was arrested about a year ago on a *capias* for defrauding his creditors. Since then the charge of fraud has been abandoned, but he has been held as a debtor.

New Bedford, Mass.

Among the traveling jewelry salesmen in town during the past week were, C. W. Findlay, of A. Paul & Co. Boston, Mass.; C. H. Howard, of the Towle Mfg. Co. Newburyport, Mass.; Henry Cohen, of Hartford, Conn.

J. T. Toky, jeweler, who for some time has shared his store with L. D. Davis, dealer in guns, fishing tackle and general sportsmen's supplies, has just purchased the latter's stock and business, and in future will conduct the whole affair.

The Pairpoint Mfg Co. have been so pressed with business during the last few seasons, that they have determined to enlarge their plant by the addition of a new four-story brick building, to contain the offices, salesrooms and storerooms as well as some portions of the factory.

Among the Watch and Clock Companies.

The Columbus factory is now employing 375 people.

Last Wednesday, a meeting of the directors of the Seth Thomas Clock Company was held.

A new stamping machine has been put in position in the engraving room at the Elgin factory.

The Illinois Watch factory which has been running five days a week is now running full time.

The Elgin Watch Company's No. 109 just issued, completes their line of six grades of size movements.

Chas. D. Rood has begun suit in partition at Canton to separate his interest in some real estate from that of John C. Dueber.

Manager Clark, of the Hampden factory, reports an increase in help and thinks the outlook is encouraging for good business this spring.

Arthur L. Keller, foreman of the finishing room at the Hampden factory, was thrown from a bicycle last week and instantly killed. Deceased was well known at Springfield, Mass., and Elgin, Illinois.

The Reams Clock Company has been incorporated at Louisville, Ky., with capital stock of \$400,000.

Superintendent Mitchell, of the Illinois Watch factory, has resigned.

San Francisco.

Arthur C. Kelley, an employee of the American Jewelry Association, left the city recently, an embezzler to the extent of \$500. Kelley was forty years of age, and weighed 180 pounds. He made collections on goods and pocketed the proceeds. The Occidental Watch Co. was also victimized by Kelley.

Burglars entered the store of George S. Horne the other night, and stole gold and silver goods valued at \$1,500. The show-cases in every part of the store were ransacked. The street show-windows were stripped of everything of value. Neither of the safes, containing diamonds and watches, were molested.

The Pairpoint Manufacturing Co., of New Bedford, Mass., have taken the store formerly occupied by Peter B. Simons & Son, at 220 Sutter street, and have placed Edward Taylor in charge of it. The stock will consist of a full line of the Company's goods, and in all respects the establishment will be the same as those in New York and Chicago.

Norfolk.

There is some talk of organizing a jewelers' association in this city.

J. W. Hinman has had a handsome clock sign erected in front of his store.

The old building recently occupied by F. Driesell, has been torn down and a handsome structure is being erected.

Local detectives are looking for a noted crook named George Cummings, alias "Red Eye," who is supposed to have stolen \$3,000 worth of diamonds from a store near Salem, Va.

E. A. Cowan, of E. A. Cowan & Co., Boston, Mass.; Max Rosenzweig, of Rosenzweig Bros., Nathan Kaiser, of Albert Lorsch, & Co., Simon Adler, of B. H. Davis & Co., New York, were in town last week.

About two years ago, Geo. W. Wougham, a jeweler near Petersburg, Va., lost \$50.00; he attributed his loss to a clerk he had discharged. The whereabouts of the clerk were traced only Saturday night.

Syracuse, N. Y.

A. Wiedman, 122 E. Fayette street, has been to Rochester on a pleasure trip.

H. R. Hukins has moved into new offices, 108 and 109 New Kirk Block, and is charmingly situated.

Abram Lewis, 7 Pike Block, is removing to new and more commodious quarters in the New Kirk Block, opposite his old place.

E. B. Midler, of W. B. Kerr & Co., of Newark, N. J., T. G. Walpuski, of the American Morocco Case Co., Will Terhune, of Henry Terhune & Son, John Robinson, of Carter, Sloan & Co., New York, Mr. Richmond, of W. E. Webster & Co., Providence, and F. R. Sheridan, of Marsh & Bigney, Attleboro, Mass., were in the city last week.

WANTED, AN ADVERTISEMENT.

I will pay Fifty Dollars in cash to the Retail Jeweler who shall prepare the best worded and most effectively displayed advertisement of *Abbott's Patent Stem-Winding Attachment*, suitable for use in Magazines and Newspapers that reach the general public.

The advertisement to occupy a space of not more than two inches high by five inches wide.

The contest will close May 1st, 1891, and the prize will be awarded within ten days from that date

**I WILL PAY
FIFTY
DOLLARS
IN CASH**

The following gentlemen will act as judges:

Mr. L. J. MULFORD,
Of The Jewelers' Circular

Mr. ALBERT ULMANN,
Of The Jewelers' Weekly

Mr. JOHN L. SHEPHERD,
Of The Keystone

Circulars and descriptive matter supplied on application.

HENRY ABBOTT,

After May 1st, 14 Maiden Lane.

4 Maiden Lane, N.Y.

WATCH * CASE * REPAIRING

WITH MY



IMPROVED MACHINERY and INCREASED FACILITIES,



I am enabled to do your work

BETTER,

QUICKER AND

CHEAPER.

IT IS TO

YOUR ADVANTAGE

TO GIVE ME A TRIAL.

G. F. FEINIER,

Manufacturer of Watch Cases; also Repairing of Every Description.

No. 9 Bond Street, New York.

Key-Wind Cases Altered to Stem-Wind, and made same as New. English Cases Altered to take American Movements.

REFERENCE: ROBBINS & APPLETON, NEWY ORK.

Providence.

E. J. Rogers is West for the Howard & Son Company.

Royce, Allen & Co., who were recently burned out, are about ready to start up again.

Mitchell & Son, of Westerly, will soon remove into improved quarters in the Opera House block.

The employees of S. K. Merrill & Co. and C. G. Bloomer's Sons enjoyed a holiday on Washinton's birthday.

Mrs. Dutee Wilcox, accompanied by her son and daughter, has gone on a four months' trip through the South.

There is talk of a base ball nine from the Gorham Manufacturing Company entering the State League this season.

The house of John T. Mauran is about entering upon the forty-second year in the manufacturing jewelry business.

It is reported that Andrew J. Wiley, formerly a manufacturing jeweler, has gone to Attleboro to engage in the fruit business.

Maurice Ettlinger, Edwin S. Tinkham and William K. Potter have been appointed District Deputy Grand Masters of the Odd Fellows.

George L. Mason, formerly of the firm of Mason Bros., has been very ill with rheumatic fever for the past fortnight at his home at Riverside.

William S. Pimm has been elected Sir Knight Herald and Walter A. Griffith, Sir Knight Guard of the What Cheer Division of the Knights of Pythias.

Edwin Lowe has been elected a member of the executive committee of the Rhode Island Chess Association. Mr. Lowe was one of the contestants in the chess tournament.

At the recent election of the Rhode Island Yacht Club, Charles G. Bloomer was elected rear admiral and trustee, and Charles J. Bloomer, Jr., chairman of the membership committee.

Horace Richardson has the deepest sympathy of his numerous friends in his double affliction, both his mother and father dying the same day the past week of pneumonia. They were each 67 years of age.

Among the members of the senior class of Brown University who have been appointed by reason of their average standing in the class to prepare commencement orations is Martin S. Fanning, son of Joseph H. Fanning, of this city.

The following well-known jewelers or wives are members of the Providence Art Club: Mrs. Charles Briggs, Mrs. F. H. Bryant, Mr. and Mrs. Hiram Howard, Stephen M. Knowles, Mrs. H. G. MacKinney, Mrs. Fred I. Marcy, Mr. and Mrs. John McAnslau, William H. Thurber, Henry Tilden, Mrs. Geo. H. Wood, Dutee Wilcox and George Wilkinson.

There are good prospects for a new jewelry manufactory being started at Warren, a town about twelve miles southeast of this city, by a well-known manufacturing jeweler of Providence. It is proposed to form a stock company and build a large three-story brick building, which is to be located in the central part of the town, and to be devoted entirely to the use of the company.

Frederick Bonner, 22 years of age, was arrested on Friday on a charge of larceny of goods valued at about \$200 from Walter E. White & Co. Bonner had been employed in that house and had always been considered a trustworthy young man, steady in habits and attentive to business. He waived examination, and was bound over to the March term of the Court of Common Pleas.

Pittsburg, Pa.

Hardy & Hayes celebrated their fifth birthday in a fitting manner last week.

James Shaefer, of Shaefer & Lloyd, has left for the East to purchase spring goods.

E. W. Hill, of Goddard, Hill & Co., is expected back from his wedding trip next Monday.

James McKee took an active part in the American Mechanics' parade on Washington's Birthday.

Sam Gallinger has been placed in charge of the business of N. Gallinger, at 12th street and Penn avenue.

An elegant silver band-box is on exhibition in the window of Durbin & McWatty. It is to be presented to the finest black and tan terrier from Allegheny County, exhibited at the bench show of the Duquesne Kennel Club.

"Petite Comtesse" in bronze is displayed in W. W. Wattles window. It is the work of Louis Hottot, Paris, and is accompanied by a certificate to the effect that it was consigned direct to Mr. Wattles, and that it is the original work.

John O. Slemmons will, in all probability, be obliged to remove from 77 Fifth avenue. He has not yet decided upon the new location. The cause of the removal is the great increase in rents that has taken place along Fifth avenue. It is probable that other jewelers will be obliged to move for the same reason.

To Manufacture Silver Goods.

The recently organized firm of silverware manufacturers, A. Ludwig & Co., 247 and 249 Centre St., has undergone a change of name. Alex. Redlich, long and favorably known to the jewelry trade of the country and for many years past in the diamond business in Maiden Lane, has joined forces with them, and the name has been changed to Ludwig, Redlich & Co. Mr. Ludwig's skill as a designer is universally acknowledged, and with so capable and experienced a business man as Mr. Redlich in charge of the office and sales department, the new firm starts out with every prospect of success.

St. Louis.

As reported in THE CIRCULAR the late John Bolland directed in his will that the goods in his Fourth street store should be sold and the proceeds invested in real estate. The final division of the property was put off until the death of certain of the heirs. The heirs being all of age and desirous of continuing the business, joined in an application to the Probate Court to have the terms of the will modified. This request was granted by the court, and the John Bolland Jewelry Company has been organized which will continue the business with John Bolland, Jr., as president. All of the stock in the company was taken by the heirs.

The Mermod-Jaccard Jewelry Co. are preparing a special room in their large establishment where they propose to make the finest display of silverware ever seen in the West. Enormous show cases are being made for the purpose. A. S. Mermod, president of the company, has been resting at Lebanon Springs for the past ten days. C. F. Mathey is preparing to leave on a purchasing trip to Europe.

The following traveling men registered at the Mermod-Jaccard Jewelry Co., last week: W. T. Gough, of Carter, Sloan & Co., R. P. Steele, of Larter, Elcox & Co., E. B. Midler, of Wm. B. Kerr & Co., H. A. Bliss, Krementz & Co., C. A. Boynton, of Enos Richardson & Co., E. J. Hopkins, of Meriden Silver Plate Co., W. R. Shute, of Day & Clark, Mr. Wallace, of J. B. Bowden & Co., and F. J. Foster, of Unger Bros.

Louisville.

Max Lowy & Co., have succeeded the Kentucky Watch Co., 543 4th avenue.

The watch club business is dying out in this city, and there are now only one or two firms that still undertake to carry it on.

It is stated that C. P. Barnes & Bro., whose store has been in the Louisville Hotel building for many years, has closed a five years' lease for a handsome store-room in the new Trust Company building, at Fifth and Market.

Wm. Kendrick, of Wm. Kendrick's Sons, has returned from Pass Christian, Miss., where he went to visit his brother, Geo. Kendrick, the invalid, who has been at Pass Christian nearly four months, and convalescing, and it is expected that he will return to the store April 1st.

The owners of large jewelry stores in this city are adopting a burglar alarm, which appears to be the thing they have been looking for for years; it is a recent invention of a St. Louis man. It consists of a series of mats, which are placed under the carpet or oil-cloth. These mats occupy no room and are not noticeable. They are so constructed that when a person steps upon them an electric circuit is closed, and a bell placed at any point, is set ringing, and does not stop ringing until the cause of the disturbance is investigated. These mats may be placed over the entire floor. They are thin and act as a protection to the carpet.

Chicago.

F. O. Hadley, of Kansas City, Mo., was in the city last week buying stock.

J. S. Gratz is visiting his brother, L. A. Gratz, who is the Mayor of Knoxville, Tenn.

Lem Flershem, of Lapp & Flershem, is said to be somewhere in New Mexico hunting bear.

Aluminum watch chains are becoming popular here. A great many of them have been sold.

J. B. Miller, of Miller, Eppenstein & Co., has returned from a two weeks' trip in the West with his bride.

T. C. Duncan, general manager of the Elgin Watch Case Co., left last Wednesday on a short Eastern trip.

Joseph Samuels, who was at one time one of the leading diamond merchants in St. Louis, is under arrest here on the charge of vagrancy.

Anticipation of the World's Columbian Exhibition with the national reputation that must naturally accrue, brought out a vein of patriotism that had heretofore laid somewhat dormant. Monday, the 23d, was pretty generally observed as Washington's birthday.

In the face of this exceptionally dull season we are having, the advent of Eastern manufacturers' representatives may rightly be termed "appalling" by the quiet jobber. A rough estimate of the salesmen about town for the past week could be put at three hundred.

Theodore Schrader who has carried on a manufacturing jewelry business at 34 and 36 Washington street for the past fifteen years will about May 1 remove to the corner of Wabash avenue and Madison street. Mr. Schrader, who is an old pioneer in the business, enjoys an extensive trade,

The store of Herbert R. Phillips, at the corner of State and Randolph streets, was robbed last week of \$300 worth of jewelry. Mr. Phillips' rooms are on the sixth floor, and the thieves effected an entrance by climbing up a fire escape from the alley. On the evening of the robbery something prompted Mr. Phillips to take the bulk of his stock home with him.

M. A. Mead, of M. A. Mead & Co., took a short spin to Detroit, one day last week. A companion was a heavy trunk, on which there was several pounds "excess baggage." A number of Wolverine jobbers admired the contents of the trunk to that extent, that on the homeward journey the trunk was many pounds lighter than when the gay "baggage smasher" tenderly deposited it in the city of Detroit.

There is considerable adverse comment on the unfavorable condition of the Union Mutual Accident Association of this city. This was a benefit company which has been quite thoroughly patronized by the traveling portion of the jewelry trade. The alleged action of the officials, just prior to making public their straightened circumstances,

causes much sharp criticism. It is claimed that an assessment of \$3.00 was sent out to every member, requesting prompt return of payment, three days before the announcement of the collapse. Many argue that so short a time as three days could not have been necessary to ascertain the inevitable.

Philadelphia.

Mr. Duckworth, representing the firm of E. S. Dodge, of Providence, stopped in the city last Friday, en route to the West.

Charles H. O'Bryon, of L. A. Scherr & Co., who had been confined to his home by sickness for a month, returned to his place of business on Friday last.

Simon Muhr was an active participant in a meeting last week in the New Century Club, when the condition of the Hebrews in Russia and the effects of the newly formed Jewish alliance was discussed.

Thomas Moore, representing L. A. Scherr & Co., returned on Friday from a fairly successful business trip through the State. On Monday James Huges, of the same house, started to tempt fortune in the South

Louis Dedlow, who died this week, was a watchmaker and jeweler for 28 years consecutively at 1023 Race street. He had been speechless and helpless for a year, owing to a paralytic stroke. He leaves a widow and three children.

C. Fitzclair Mayers, superintendent of the gold mining expedition sent to British Guiana by the Home Gold Extracting Company, 328 Chestnut street, died recently at St. Kitts, one of the Leeward Islands. His associate, S. E. Johnson, succeeds him in charge of the expedition.

A couple of bogus gold ring peddlers who gave their names as Frank Henderson and Charles Hickey, were arrested last week. Magistrate Pullinger held Henderson in \$500 bail for court, and Magistrate O'Brien sent Hickey to the House of Correction for three months.

Cincinnati.

Hugo Jonas, of Jonas, Dorst & Co., leaves this week on his regular trip.

Numerous jewelers are in town attending the great Masonic Conclave, but are buying no goods.

Duhme & Co. have on exhibition a silver horseshoe with gold nails, made by Harry Coffin, who has but one arm.

A. Herman is suffering from a very serious eye trouble. He is under treatment that will keep him off the road for some time.

Jos. Homan has returned from his Eastern trip, where he succeeded in placing his firm's very excellent goods among the best houses.

Duhme & Co. have just issued three new designs in 18 size watch cases that are sure to be takers. The upright and circular and corrugated with vermicelli centres. Their ladies' 6 and o sizes in decorated patterns with diamond setting have had a splendid run.

Connecticut.

Secretary Geo. H. Wilcox, of the Meriden Britannia Co., left Saturday for Chicago.

The E. A. Bliss Co., Meriden, are increasing their facilities. Seven more men were added to the force.

Geo. R. Curtis, of the Meriden Britannia Co., sailed for the Bermudas last Thursday, to be away one month.

Another enlargement of the factory of R. Wallace & Sons Mfg. Co., Wallingford, is to be effected. Another large brick building is to be added. They employ now about 450 hands, and when the new addition is built about 100 more will be required.

S. R. Parlin, at one time one of the best known jewelers in eastern Connecticut, died at his home in Norwich, Conn., on Friday night, aged 64 years. First he was in the bleachery business, then he was one of the '49ers of California, in which State he amassed a fortune. He was in the jewelry business for about thirty years.

A strike last week broke out among the engravers at the Middleton Plate Company's works. They struck because the company had employed a new man in that branch of their business at higher wages than the rest were receiving. On Thursday, however, the matter was amicably settled by the company and all the engravers returned to work.

Rochester.

Philip Present has been forced to seek enlarged quarters, and he is now established on the first floor of the magnificent twelve-story Wilder Building. Mr. Present has added a stock of optical goods, and has secured the services of his brother Jacob to handle that line on the road.

C. A. Gillett, who has been doing a very successful business at 182 East Main street, disposed of his stock and good will last week to Bowen & Hoye, of New York City, who will continue the business. The store will be newly-fitted up and a new and extensive stock added, which Mr. Bowen is now selecting in New York. F. H. Bowen was recently in business for himself in New York, while W. J. Hoye was formerly employed at Tiffany's. Mr. Gillett will open a repair shop in the Reynold's Arcade.

Three girls worked several local dealers this week for a number of rings. They visited the various jewelers' stores for the ostensible purpose of ordering a ring set with an opal. One would conceal a ring in her muff and pass it to her companion who would leave the place. B. E. Brown lost an \$18 ring, and among other victims were McAllaster & Humburch, David Rosenberg, C. W. Ricketts and E. S. Ettenheimer & Co. One of the girls was arrested but nothing was found either on her person or in her room and as she said her accomplices had left for the East, she was discharged. The matter was not made public.

GORHAM MFG. CO.

Silversmiths.

SOLID SILVERWARE.

Manufacture and carry in stock the largest assortment of Solid Silver Ware to be found in the country, including specimens of art work of the most elaborate and costly design, as well as articles of plainer and more simple forms suitable for household use.

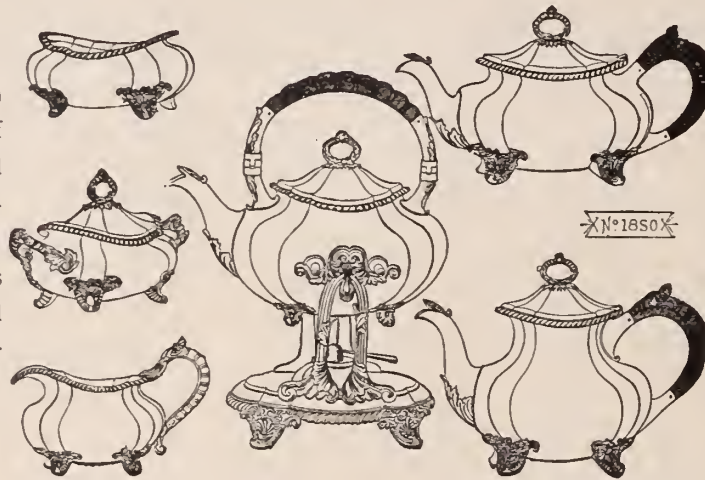

Gorham Mfg. Co.'s Branch Houses:
 9 Maiden Lane, N. Y.
 137 & 139 State St., Chic., Ill.
 120 Sutter St., San Fran., Cal.
 36 Avenue de l'Opera, Paris,
 France.

WORKS: PROVIDENCE, R. I.

ALL COMMUNICATIONS SHOULD BE ADDRESSED,

Broadway and 19th St., New York.

ALFRED H. SMITH & CO.,

DIAMONDS,

182 BROADWAY,

COR. JOHN STREET,

NEW YORK.

33 HOLBORN VIADUCT, LONDON, E. C.

THE JEWELERS' CIRCULAR AND HOROLOGICAL REVIEW.

PUBLISHED EVERY WEDNESDAY BY

THE JEWELERS' CIRCULAR PUB'G CO.,
AT NO. 189 BROADWAY, NEW YORK CITY.

Members of the American Trade Press Association.

A JOURNAL DEVOTED TO THE INTERESTS OF WATCHMAKERS, JEWELERS, SILVERSMITHS, ELECTRO-PLATE MANUFACTURERS AND ALL WHO ARE ENGAGED IN KINDRED BRANCHES OF INDUSTRY.

Terms of Subscription, Postage Prepaid.

	PER ANNUM
United States and Canada, - - -	\$2.00
To all Foreign Countries, - - -	4.00
Single Copies, - - - - -	.10

ADVERTISEMENT.

Business letters, drafts, checks and post-office orders should be addressed to THE JEWELERS' CIRCULAR PUBLISHING COMPANY, No. 189 Broadway, New York city.

Manuscript from any quarter containing news or discussion of any technical subject within the field covered by THE CIRCULAR will be welcomed. Matter received that proves unsuitable or unavailable will be returned if accompanied by the necessary postage stamps.

Our editorial columns will contain our own opinions only, and we shall present in other columns only what we consider of interest or value to our readers. Applications to print advertising matter as news will not be considered.

Advertising rates in THE CIRCULAR are lower, considering the number of tradesmen reached by its large circulation, than in any other jewelry journal.

Notices of changes in standing advertisements must be received one week in advance, new matter can be received up to Saturday.

VOL. XXII. MARCH 4, 1891. No. 5.

Senate Bill **No. 107.** IN their eager desire to find subjects for taxation, and in particular to make commerce and industry a source of revenue to the State, the legislators at Albany have lately introduced in the Senate a bill (Senate Bill No. 107), which proposes to amend the present personal tax law by striking out the words, "after deducting the just debts owing by him." What would be some of the effects of imposing a tax upon all personal property, goods and merchandise, manufactured and unmanufactured, found in stock in the establishment of business men, without any allowance for the debts owing by such persons at the time? The number of manufacturers (at present very large) who find it to their advantage to have their factories in New Jersey or some other neighboring State, would be greatly increased. Manufacturers would lay in a minimum of raw material, and jobbers and retailers a minimum of finished goods, and the stimulus to business given by the handling of extensive lines would be lost. The greatest care should be

exercised in devising legislation directly affecting business. The proposed amendment will tax a man on what he owes, not what he has. The bill should be smothered in its birth.

Some Words on Advertising.

A FIRM can lay in a stock of advertising as it can a stock of goods. Merchandise does not always prove profitable; so may be the case with advertising. If a firm appropriating an amount of money for a period of advertising does not place its announcement in the proper channel and in the proper manner, the result financially will be the same as it would be were a line of goods, carried by the house old in style and poor in workmanship. Advertise in a proper channel without regard to the manner of so doing, and the investment will prove fairly profitable; advertise in a wrong channel in an individual and striking manner, and the result may be profitable; combine the two requirements and the money invested for the purpose will bring more than its face value and State interest. THE CIRCULAR believes this, and it strives to materialize its belief. That it has succeeded is evidenced by the many unsolicited testimonials it has received from its advertisers.

Law Against Plating Coin.

A DISPATCH TO THE CIRCULAR from Boston, Mass., recounts the trial of a jeweler of Cambridge, indicted for violating the law relating to the plating of coin. The prohibitory law was enacted a few years ago, when a new issue of five cent nickels made counterfeiting easy and profitable. The gold plating of a base metal coin on the order of a customer seems to be a very simple matter; but when it is remembered that the customer may endeavor to pass it off as a coin of genuine gold, the law will be appreciated as a good one, worthy of being carried out to the letter. There was no evidence of criminal intent, still the imposed fine of \$100 more than equals the profits added to a jeweler's business by the sale of watch charms consisting of gold-plated five cent pieces.

The Week in Brief.

Fire devastated two jewelry stores at Edina, Mo.
A jeweler at Cambridge, Mass., was arrested for violating the law relating to the plating of coin.
A would-be thief used a sandbag at Stamford, Conn.
The New Haven court acquitted Auctioneer Cummings.
The missing Montreal jeweler still unheard from.
A. D. White, of New Haven, Conn., S. R. Parlin, Norwich, Conn., Louis Dedlow, Philadelphia, Pa., and G. A. Remington, Edward V. Anness and L. T. Best, of New York, expired.

The Lancaster Watch Factory will be sold at auction.

The American Association of Opticians held their third meeting.

The report of the gold and silver production of 1890 was presented to Congress.

The name of G. & S. Owen retired from the trade.

A brilliant wedding at Delmonico's in New York.

Sumner Bro.'s offer of settlement was refused.

An old confidence game was worked successfully on N. F. Schmidt, of St. Louis, Mo.

A receiver for Towne & Ingraham, Providence, R. I., was petitioned for.

The Cincinnati Jewelers' Association elected their officers for the year.

Warren, R. I., is to have a large jewelry manufactory.

The window smasher worked successfully at Birmingham, Ala.

The John Boland Jewelry Company was organized at St. Louis, Mo., and the Voigt Manufacturing Jewelry Company at Washington, D. C.

St. Louis, Mo., jewelers' are adopting an effective burglar alarm.

The condition of the Union Mutual Accident Association, of Chicago, Ill, is exciting adverse criticism.

Bogus gold ring peddlers were arrested in Philadelphia, Pa., and Pawtucket, R. I.

The R. Wallace & Sons Manufacturing Company, Wallingford, Conn., and the Pairport Manufacturing Company, New Bedford, Mass., will increase their plants.

Three girls worked Rochester, N. Y., jewelers for rings.

Factory Inspector Margaret Finn visited the New York jewelry district.

Suit has been instituted against several Park Row, New York City, pawn-brokers.

The Gorham Manufacturing Co. thieves were sentenced.

George C. Comstock ceased as attorney for the N. Y. Jewelers' Board of Trade.

Stern & Frank, New York, settled amicably with their workmen. The employees of L. Greenstein, New York, who also struck, returned to work.

A. Horowitz, Hudson, N. Y., effected a settlement with his creditors.

Burglars are exciting the citizens of Camden, N. J.

Burglars robbed the store of G. S. Horne, San Francisco, Cal.

The stockholders of the McBride & Marcellus Co. are fighting for the assets.

After the Kansas City, Mo., fire.

A sprinter made off with the valise of a Chicago jewelry salesman.

I. M. Seckel's jewelry display tempted a window smasher in New York.

M. Wertheimer, Cleveland, O., was robbed while at dinner.

New York Notes.

Fellows & Co. will go out of business on May 1.

The Celluloid Novelty Co., have moved from 313 to 427 Broadway.

On May 1, A. Alling Reeves will move from 21 to 25 Maiden Lane.

J. Kurtz has secured a judgment against Cæsar A. Cuppia for \$436.12.

Dattelbaum & Friedman have secured a judgment against Isaac Lesselbaum for \$134.-09.

M. D. Cohn, of I. Michelson & Co., will start on March 10 on a three months' trip through the West.

J. E. Simonson, of A. J. Hedges & Co., on Monday departed on a four weeks' trip through the South and West.

R. A. Kipling and William B. Kerr & Co., have been admitted to membership in the New York Jewelers' Association.

The engagement of Miss Jenny Fuhr, daughter of William Fuhr, of 980 Second avenue, to Otto Wolff is announced.

Geo. A. and Edmund C. Viemeister have recorded against them a judgment for \$673.-94 in favor of Weis & Oppenheimer.

Frederick Hoyt, for many years with S. Cottle Co., has established himself as a manufacturing jeweler on Twenty-sixth street.

Traitel Bros. and The New York Company, which are really the same firm, will undoubtedly give up business on or before May 1.

On Saturday evening, March 14, George F. Kunz will deliver an illustrated lecture at Cooper Institute on "Gems and Precious Stones."

E. E. Kipling arrived from Paris on February 22d, on the *Saale*, and brought with him a large assortment of diamonds, fancy stones, etc.

Dennis Leary was held in the Tombs Police Court, last Tuesday, for stealing a watch valued at \$18 from Nathan Frank, of 26 Bowery.

Among those who attended the annual ball of the Purim Association at the Metropolitan Opera House last Thursday evening were: S. Oppenheimer, David Untermeyer and Leopold Weil.

A. K. Shiebler, of Jeannot & Shiebler, sailed to Europe last Wednesday on the *Saale*. He will be gone three or four months, and will devote himself to the pursuit of comfort and recreation.

The Dithridge Flint Glass Company, cut-glass manufacturers, New Brighton, Pa., have just finished some improvements in their New York sample room, No. 48 Park Place, which is in charge of J. H. Hartpence.

Jacob N. Bonnet on May 1 will move from 21 Maiden Lane to 26 John street, into the office now occupied by R. A. Breidenbach. He will remain there until the completion of the new Hays' building at 21 and 23 Maiden Lane, when he will move back.

A one-armed man who subsequently refused to give his name, smashed one of the plate glass windows of Morris Hode's store, 381 Grand street, last Friday evening. While attempting to escape with a tray of watches from the window he was captured by Mr. Hode and handed over to the police.

During the past month Factory Inspector Margaret Finn visited many of the workshops in the jewelry district. She suggested many improvements, among which was the erection of fire escapes on several of the more old-fashioned buildings. These fire escapes are now being placed in position.

Last Thursday, the water main of John street in some unaccountable manner became charged with electricity from the Broadway conduit and escaped from the many plugs in the centre of the street. For hours the sidewalk was lined with a tickled crowd of people, as they watched the queer antics of passing horses when they stepped on the charged spots.

The People's Watch Company, of 60 Broadway, have begun suits in various district courts against John Simpson & Co.,

William Simpson, and J. Hamerschlag Sons to recover the value of jewelry pawned with them, which it is claimed was fraudulently obtained from the plaintiffs by one John McGinniss. The value of the jewelry is placed at \$313.

Some time ago C. H. Hollis, La Grange, Ind., failed, and among the creditors were Rogers & Bro. After the assignment that firm levied an attachment against Mr. Hollis and began suit to set aside a mortgage on his stock which he had given previous to his failure. Last week news was received in this city that the courts had decided this action in favor of the plaintiffs.

Joseph M. Bolton, Richard Pennell and John G. Williams, concerned in the robbery of about \$1,500 worth of silverware from the Gorham Mfg. Co., as reported in the CIRCULAR, were last Friday sent to the Elmira Reformatory. Pennell's counsel pleaded for a suspension of sentence. He said that the youth's uncle, connected with a large steamship company of San Francisco, had offered, if Pennell was released, to establish him in business in California. Judge Fitzgerald, however refused to release the prisoner.

◆—DIAMONDS—◆

Our Diamond Stock in the future will be separated into twelve grades, as follows:

- A. Blue-White and Perfect.
- B. " " " Imperfect.
- C. Extra White and Perfect.
- D. " " " Imperfect.
- 1. White and Perfect.
- 2. " " Slightly Imperfect.
- 3. " " Imperfect.
- 4. Very Good Color and Perfect.
- 5. " " " Slightly Imperfect.
- 6. " " " Imperfect.
- 7. Good Color and Perfect.
- 8. " " " Imperfect.

Copyrighted August 15, 1890.

Copyrighted August 15, 1890.



Each piece in addition to the regular number will have one of above letters or numbers to indicate the quality of the diamond. This will give you the benefit of our judgment as to the grade and quality of each stone, and, we believe, will help you in the purchase and sale of diamonds from our stock.

When in need of anything special in diamonds, send to us for an assortment on selection. Don't hesitate because you may never have had any previous dealings with us, as we should be glad to have you for a customer—and to have you give this new grading system of ours a trial.

J. T. SCOTT & CO.,

4 MAIDEN LANE.



NEW YORK.

Mrs. Ada Fish, a daughter of John Waters, of John Water's Sons, 12 John-street, was burned to death last Saturday.

R. A. Kipling will next month move from 860 Broadway to 189 Broadway, where he will share the offices of Peterson & Royce.

George Carleton Comstock, for many years counsel for the New York Jewelers' Board of Trade, has ceased to be connected with that organization.

Jonas Koch, of Koch & Dreyfus, is temporarily looking after the firm's customers in Texas and the South, formerly covered by the late Emil Schorbach.

Last Friday the workmen of Leopold Greenstein, 80 Nassau street, struck for an advance of wages. The demand was complied with and the men resumed work.

Robert S. McDowell, one of the oldest chronometer makers in the city, died last week at his home in Brooklyn. He was for many years engaged with Creighton & Black and T. S. & J. D. Negus, of this city.

Last Friday Judge Ingraham heard a motion to vacate the attachment against Viemeister Bros. in favor of H. Henrich. The lawyers were allowed until this Friday to submit their briefs, and it will be two weeks before a decision is rendered.

L. T. Best, for the past seven years a salesman for Eisenmann Bros., 22 Maiden Lane, died Monday from an operation. Mr. Best had many friends in the trade among whom his unexpected demise has excited sincere sorrow. He was a member of the Jewelers' League.

The workmen of Stern & Frank, of 10 Maiden Lane, went on strike again last Thursday, because the firm refused to discharge a non-union workman. The difficulty was subsequently settled, however, by the men taking the objectionable jeweler into their union and returning to their benches.

Judge Andrews in the Supreme Court, last Friday, signed an order granting Fettrich, Silkman & Seybel, attorneys for Goodman & Rosenberger, an extra allowance within costs against R. A. Breidenbach, whose suit in connection with Goodman & Rosenberger's failure was decided against him some weeks ago.

The examination of C. A. Bailey and John Tiedman, arrested for conducting a lottery scheme under the guise of a watch club, was adjourned for one week when brought up in the Tombs last Saturday. The charge of using the mail for unlawful purposes, which is being prosecuted by the government authorities, will be heard on March 11.

Max Freund, of Max Freund & Co., arrived from Europe last Sunday on the *Umbria*. He reports the diamond market as being very firm owing to the demands of the European trade, which is at present enjoying unusual prosperity. Mr. Freund, whose opinions are much sought after, says that there is no fear of the present prices of diamonds decreasing for some time to come.

J. F. FRADLEY & CO.,

Manufacturers of a General Line of

REPOUSSÉ SILVERWARE, MATCH BOXES IN SOLID GOLD AND STIFFENED GOLD, GOLD HEADED CANES, &c.

Office and Salesroom, 23 JOHN STREET,
NEW YORK.

DORFLINGER'S AMERICAN CUT GLASS.

The Finest Crystal, Plain and Cut, made in the World.



EVERYTHING that is
used in Glass, for
the Table.

Sells as well as Silver-
ware.

EVERY FIRST-CLASS JEWELER

C. DORFLINGER & SONS,

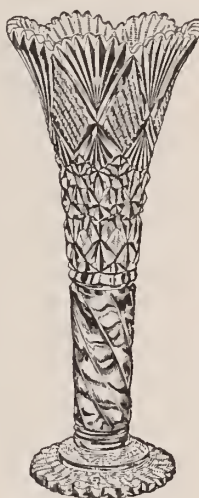

BEAUTIFUL, Artistic
and Useful Pieces
for Gifts.

Rivals the Diamond for
Purity and Lustre.

SHOULD KEEP IT.

36 Murray Street, New York.



Fleur de Lis "VICTORIAS."

WE ARE SHOWING THE

Most Popular Line

IN THE MARKET.

H. F. BARROWS & Co.,

1½A Maiden Lane, N. Y.

BIPPART & Co.
MANUFACTURERS
OF
Fine Jewelry.
Cor. Marshall & Halsey Sts
Newark, N. J.
NOVELTIES AND DIAMOND MOUNTINGS

CLASSIFIED INDEX TO ADVERTISEMENTS.

All Advertisements are entitled to one insertion under proper heading. Extra insertions, \$6.00 per Annum. Extra Headings \$12.00 per Annum.

	PAGE.		PAGE.		PAGE.
Assayers & Refiners.		Gold and Silver Platers.		Silk Guards.	
Goldsmith Bros., Chicago, Ill.....	47	Newman, Louis, Jr., 36 John st., N. Y.....	37	Rosentall, Wm., 79 Nassau st., N. Y.....	45
Howard, S. P., 8 John st., N. Y.....	48	Gold Chains.		Silver Plated Ware.	
Robertson & Leber, 13 Franklin st., Newark, N. J.....	41	Rickert & Stiehle, Newark, N. J.....	46	Pairpoint Mfg. Co., New Bedford, Mass.....	5
Auctioneers.		Horological Schools.		Rogers & Hamilton Co. The, Waterbury, Conn.	48
Comrie, A. J., 16 West 125th st., N. Y.....	31	Chicago School of Horology, Chicago, Ill.....	40	Rogers & Bro., 16 Cortlandt st., N. Y.....	7
French, J. H., Box 2775, N. Y.....	35	Elgin Horological School, Elgin, Ill.....	45	Rogers, Wm., Mfg. Co., Hartford, Conn.....	12
Badges, Medals, etc.		Waltham School of Horology, Waltham, Mass.	39	Stem-Winding Attachments.	
Stockwell, E. R., 17 John st., N. Y.....	16	Jewelry Repairers.		Abbott, Henry, 4 Maiden Lane, N. Y.....	21
Black Onyx Jewelry.		Juzek, Thos. & Co., Elgin, Ill.....	9	Sterling Silver Novelties.	
Woglom, Gilbert T., 32 John st., N. Y.....	47	Wiederhold, A., 20 Maiden Lane, N. Y.....	14	Alvin Mfg. Co., 860 Broadway N. Y.....	14
Books, Stationery, etc.		Jewelers' Scales.		La Pierre, F. H., 18 East 14th st., N. Y.....	7
Chicago Envelope Clasp Co., Chicago, Ill.....	46	Troemner, Henry, 710 Market st., Philadelphia, Pa.....	12	Lewis Bros., 41 Maiden Lane, N. Y.....	46
Dickie, W. B., 67 William st., N. Y.....	12	Jobbers, Watches, Diamonds, etc.		Sterling Silverware.	
Bronze Ornaments.		Aikin, Lambert & Co., 23 Maiden Lane, N. Y.	37	Durgin, W. B., Concord, N. H.....	15
Muller Bronze Co., Brooklyn, N. Y.....	2	Beguelin, Tell A., 71 Nassau st., N. Y.....	34	Fradley, J. F. & Co., 23 John st., N. Y.....	27
Chronometers.		Bowman & Musser, Lancaster, Pa.....	19	Gorham Mfg. Co., 19th st. & Broadway N. Y..	24
Heinrich, H. H., 14 John st., N. Y.....	40	Conover, D. F. & Co., Philadelphia, Pa.....	5	Ludwig, Redlich & Co., 247 Centre st., N. Y..	31
Clock Manufacturers.		Cross & Beguelin, 21 Maiden Lane, N. Y.....	4	Mausser, Frank & Co., 30 Union Square, N. Y..	29
Schlenker, E. R., Schwenningen on Neckar, Germany.....	17	Friedlander, R. & L., 65 Nassau st., N. Y.....	34	Shiebler, Geo. W., 6 Liberty st., N. Y.....	10
Waterbury Clock Co., 10 Cortlandt st., N. Y..	40	Koch & Dreyfus, 22 John st., N. Y.....	31	Towle Mfg. Co., Newburyport, Mass.....	35
Cut Glass.		Myers, S. F. & Co., 48 Maiden Lane, N. Y.....	48	Wallace, R. & Sons, Mfg. Co., 3 Park Place, N. Y.....	6
Clark, T. B. & Co., 53 Park Place, N. Y.....	47	Scott, J. T. & Co., 4 Maiden Lane, N. Y.....	26	Wood & Hughes, 16 John st., N. Y.....	9
Dorfinger, C. & Sons, 36 Murray st., N. Y.....	27	Yates, John B., 147 Nassau st., N. Y.....	31	Tool Manufacturers and Dealers.	
Diamond & Precious Stone Importers.		Key Chains.		American Watch Tool Co., Waltham, Mass....	36
Hedges Wm. S. & Co., 170 Broadway, N. Y....	39	Ingersoll, R. H., Bro., 65 Cortlandt st., N. Y..	40	Bullock, O. W. & Co., Springfield, Mass.....	39
Hirschberg, Sig., 78 Nassau st., N. Y.....	17	Mexican Onyx Goods.		Nordman Bros., San Francisco, Cal... ..	17
Kahn, L. & M. & Co., 10 Maiden Lane, N. Y.	48	Klaber, S. & Co., 47 W. 42d st., N. Y.....	12	Swartchild & Co., Chicago, Ill.....	9
Kipling, E. E., 2 John st., N. Y.....	48	Musical Boxes.		Typewriters.	
Kipling, R. A., 31 Union Square, N. Y.....	39	Jacot & Son, 298 Broadway, New York.....	47	Wyckoff, Seamans & Benedict, Broadway, N. Y.	37
Oppenheimer Bros., & Veith, 35 Maiden Lane, N. Y.....	15	Optical Goods.		Watch Companies.	
Pinover, A. & Co., 25 Ann st., N. Y.....	47	Geneva Optical Co., 23 Washington st., Chicago, Ill.....	17, 31, 39, 40	Non-Magnetic Watch Co., 177 Broadway, N. Y.	10
Randei, Baremore & Billings, 29 Maiden Lane, N. Y.....	7	Scheidig, John & Co., 43 Maiden Lane, N. Y..	16	Start.....	39
Smith, Alfred H. & Co., 182 Broadway, N. Y..	24	Spencer Optical Co., 15 Maiden Lane, N. Y..	2	Trenton Watch Co., Trenton, N. J.....	13
Taylor & Bro., 860 Broadway, N. Y.....	41	Zinemer, M. & Bro., Philadelphia, Pa.....	37	Watch & Clock Dials.	
Diamond Cutters.		Order Work.		Waltham Dial Co., Waltham, Mass.....	17
Groenman, A. J. & Co., 80 Nassau st., N. Y....	46	Maxheimer & Beresford, 3 Maiden Lane, N. Y.	17	Watch & Clock Oils	
Diamond Jewelry.		Pens, Pencil Cases, Etc.		Ginnel, Henry & Co., 31 Maiden Lane, N. Y..	46
Falkenau, Oppenheimer & Co., 40 Maiden Lane, N. Y.....	48	Aikin, Lambert & Co., 23 Maiden Lane, N. Y.	37	Nye, William F., New Bedford, Mass.....	40
Ludwig, Nissen, & Co., 18 John st., N. Y.....	14	Ring Makers.		Watch Keys.	
Stern Bros., 42 Maiden Lane, N. Y.....	39	Bryant, M. B. & Co., 10 Maiden Lane, N. Y., 46	46	Clark, A. N., Plainville, Conn.....	41
Sexton Bros. & Washburn, 41 Maiden Lane, N. Y.....	39	Haskell, H. C., 192 Broadway, N. Y.....	34	Kendrick & Davis, Lebanon, N. H.....	41
Engravers and Designers.		Hildreth Mfg. Co., 51 Maiden Lane, N. Y.....	14	Watch Case Manufacturers.	
Bartholomew & Peckham, 18 Spruce st., N. Y.	46	McCall, Wm. E., 625 Arch st., Philadelphia, Pa.....	41	Courvoisier, Wilcox Mfg. Co., 41 Maiden Lane, N. Y.....	12
Ryder & Dearth, 146 Westminster st., Provi- dence, R. I.....	47	Ostby & Barton, 80 Clifford st., Providence, R. I.....	15, 18	Crescent Watch Case Co., 5 Bond st., N. Y....	43
Eye Glass Holders & Chains.		Wood, J. R. & Sons., 14 John st., N. Y.....	12	Essex Watch Case Co., Newark, N. J.....	10
Merritt, S. F., Springfield, Mass.....	11	Rolled Plate Chains.		Jeannot & Shiebler, 20 Maiden Lane, N. Y....	10
Fine Jewelry.		Barrows, H. F. & Co., 1½ A, Maiden Lane, N. Y.....	27	Muhr's Sons, H., 629 Chestnut st., Philadelphia, Pa.....	48
Day & Clark, 10 Maiden Lane, N. Y.....	31	Kent & Stanley, 7 Eddy st., Providence, R. I....	3	Roy Watch Case Co., 17 Maiden Lane, N. Y.	48
Gas Engines.		Rolled Plate Jewelry.		Wadsworth, H. A. & Co., Newport, Ky.....	38
Schleicher, Schumm & Co., Philadelphia, Pa...	16	Crossin & Tucker, 409 Pine st., Providence, R. I.....	16	Watch Case Repairers.	
Gold Jewelry.		Flomerfelt, J. A. & Co., 177 Broadway, N. Y..	48	Feinier, G. F., 9 Bond st., N. Y.....	21
Bippart & Co., Newark, N. J.....	27	Foster & Bailey, 60 Richmond st., Providence. R. I.....	45	Watch Importers.	
Carter, Sloan & Co., 15 Maiden Lane, N. Y....	33	Ludwig, H. & Co., Providence, R. I.. ..	47	Abry, Chas. L., 41 Maiden Lane, N. Y.....	40
Cottle, S. Co., 860 Broadway, N. Y.....	37	Plainville Stock Co., Plainville, Mass.	34	Mathey Bros., Mathez & Co., 14 Maiden Lane, N. Y.....	11
Kremenz & Co., 182 Broadway N. Y.....	17	Seamless Wire.		Wittnauer, A., 30 Maiden Lane, N. Y.....	45
Larter, Elcox & Co., 41 Maiden Lane, N. Y....	7	Burdon Seamless Filled Wire Co., Providence, R. I.....	34	Watch Materials, &c.	
Moore & Horton, 11 Maiden Lane, N. Y.....	14	Settings & Galleries.		Cross & Beguelin, 21 Maiden Lane, N. Y.....	4
Riley, J. A., & Sloan Co., 860 Broadway, N. Y.	15	Blancard & Co., 36 John st., N. Y.....	34	Friedlander, R. & L., 65 Nassau st., N. Y.....	34
Snow & Westcott, 3 Maiden Lane, N. Y.....	4, 41	Silk Guards.		Keller, L. H. & Co., 64 Nassau st., N. Y.....	11
Street, Geo. O. & Sons, 15 John st., N. Y.....	17	Silver Plated Ware.		Watch Repairers.	
		Rosentall, Wm., 79 Nassau st., N. Y.....	45	Simmonds, J. C., 18 John st., N. Y.....	40
		Stem-Winding Attachments.		Welded Steel.	
		Abbott, Henry, 4 Maiden Lane, N. Y.....	21	Chrome Steel Works, Brooklyn, N. Y.....	37

Special Notices.

Rates 75c. per insertion for notices, not exceeding 3 lines; additional words 2 cents each. If answers are to be forwarded, postage stamps must be enclosed. Two insertions, 10 per cent. off; three insertions, 15 per cent. off; four insertions, 25 per cent. off. Payable strictly in advance.

Situations Wanted.

THE JEWELERS' CIRCULAR has a guaranteed circulation of over 10,000 copies weekly. It is, therefore, the best medium for reaching the trade. To demonstrate this to advertisers, notices in this column will be inserted free of charge during the month of March.

A JEWELER, first-class repairer and jobber, also line engraver, wants a steady position; 11 years' experience; English, German and Scandinavian languages spoken; best references from former employers. Address, Jeweler, 45, JEWELERS' CIRCULAR.

A POSITION wanted under a first-class workman, to finish trade. Have had 2½ years' experience, and some knowledge of optical goods; can furnish A 1 reference. Address Box 57, Alfred Centre, N. Y.

A NICKEL PLATER desires a situation; thoroughly understands the business; can give best of reference if required. Address, Plater B, this office.

A LIVE young man of ability and experience desires position with responsible house to represent them on the road; jewelry or watches preferred; familiar with southern trade; A 1 references. Address, Salesman, care of JEWELERS' CIRCULAR.

COMPETENT book-keeper, disengaged after 3 y. m., would like employment; terms moderate. Address, H. P., care of JEWELERS' CIRCULAR.

FIRST CLASS watchmaker with twenty years' experience, wants a position in New England States; can give first-class references; German descent, four years in U. S. Address, A. L., care of E. F. Rohn, 304 Chestnut street, Milwaukee, Wis.

POSITION WANTED by an experienced and A1 traveling salesman; good references given. Address H. F., care THE JEWELERS' CIRCULAR.

SALESMAN wishes position in first class manufacturing house. Good trade in City, Brooklyn, N. Y. State, Phila., Balt., and Washington. Address Hustler, JEWELERS' CIRCULAR.

SITUATION wanted after March 1 by sober man with 10 years' of practical experience at watch and jewelry repairing; also as salesman; good set of tools; can give good reference. Address, P. O. Box 226, Camden, Mich.

WANTED.—We have in our employ a young man about 24 years old who has been with us about 4 years, excellent habits, a good salesman, watchmaker general repairer and plain letter engraver; he is worth more than we can afford to pay and would like to get him a good position at about \$15 per week. Address, Lock Box 044, Lyons, Wayne Co., N. Y.

WANTED.—Position by a first class watchmaker, clockmaker, jeweler, and repairer of musical toys, etc. Can put my hands to any variety of repairing work. Have had thirty years' experience; can furnish best of references and security if desired. Would prefer a position in New York City or nearby town. Address, D. H. J., care THE JEWELERS' CIRCULAR.

WANTED.—A married man about 38 years, with 18 years' experience, at the bench, would like position with first-class house; wages \$13 per week. Am strictly temperate and honest; best of references, have my own tools. Address Epworth, care JEWELERS' CIRCULAR.

WANTED.—By a young man of 23, position as assistant watchmaker under finished workman, where I can be instructed on difficult and complicated work. Have had between 2 and 3 years' experience; am strictly temperate, and can give best of reference. Address "L," 224 Main street, Middletown, Conn.

WANTED.—By a single man, 26 years of age, a position in a wholesale jewelry or diamond importing house, as salesman in office or to travel. Have had five years' experience in a retail jewelry store. Highest references given. Address, V. Z., care JEWELERS' CIRCULAR.

WANTED.—Situation by a watchmaker of 15 years' experience; full set of tools and best references furnished; North or West preferred. Address, C. A. S. Edgett, 45 East Mitchell street, Atlanta, Ga.

WANTED.—Position by young man; with five years' experience in watch, clock and jewelry repairing; A 1 references. Address, Watchmaker, Box 102, Charles City, Iowa.

YOUNG MAN with six years' experience, who understands watch and clock work, when not complicated, would like a position with a first class watchmaker, to finish learning the trade. Is temperate, honest and industrious, and has all necessary tools except American lathe. Best reference; moderate salary expected at first. Address Jas. H. Grubb, Clearville, Pa.

YOUNG MAN who understands hard soldering and can do clock-work and watch-work when not complicated, would like to get a position with a first class watchmaker and finish trade. Temperate, honest, industrious and does not use tobacco. Expects a reasonable salary to commence. Have good mechanical ideas. Some tools. Address, F. E. Hackett, Box 476, Baton Rouge, La.

Help Wanted

A FIRST CLASS watchmaker wanted; wages, \$20 per week. Send photograph and sample of work to P. H. Lachicotte & Co., Columbia, S. C.

WANTED.—A first class traveler. One acquainted with Texas trade preferred; good salary. Address, Koch & Dreyfus, 22 John street, New York.

WANTED.—A thoroughly competent watchmaker and jewelry repairer in New England city; must have tools and experience, and be well recommended; state age, experience, and salary desired. Address Good Opportunity, care JEWELERS' CIRCULAR.

WANTED.—A few traveling men who are practical watchmakers, and have the time—to call the attention of the craft to the Mosely Lathe and Attachments, through the East and Southwest. Address, Mosely & Co., Elgin, Ill.

For Sale.

A FINE ship chronometer for sale cheap. Address: A. C. Taylor, Cedar Rapids, Iowa.

FOR SALE or exchange for goods, a large Herring or Terwilliger jewelry safe. Address, T. B. Bynner, 177 Broadway, N. Y.

FOR SALE.—A Mosely No. 1, soft lathe with ten chucks, countershaft, footwhale and universal face plate all nearly new. Also one standard lathe cheap. Wanted to buy, or will trade the above for a No. 3, hard American lathe or a watch factory machinist's bench lathe. Address, Box 1407, Rockford, Ill.

To Let.

TO MANUFACTURING JEWELERS AND OTHERS.—A floor to let in the new improved factory building, corner St. Marks and Underhill avenues, Brooklyn. Fine light, power and all modern improvements; within twenty minutes of the Brooklyn ferries. Apply to Geo. W. Shiebler, 8 Liberty Place, New York City.

TO LET.—First floor back, No. 18 John street, 3 windows; possession at once if desired. Apply to Chas. Magnus.

Business Opportunities.

\$4,000 IN CASH will buy out a business in best jewelry city in America, of 300,000; opening seldom offered. For particulars, write C. B., care of THE JEWELERS' CIRCULAR.

JEWELRY and music store in a growing town in eastern Penn., can reduce stock to \$1,500; light opposition; low rent; must sell on account of poor health. Address, G. W., care of JEWELERS' CIRCULAR.

Miscellaneous.

JEWELERS wishing to become thorough opticians, should send for particulars in reference to my course of mail instructions. Address, Dr. H. L. King, Helena, Mont.

W. A. SCHROETER, 298 Grand street, New York City. Estimates rendered on any desired job. Four expert watch repairers employed specially for Trade Work. Guaranteed finely finished at low prices. Also a good chance for a young man to study watchmaking.

W. F. A. WOODCOCK'S SCHOOL FOR WATCH makers, Winona, Minn., offers unrivaled facilities for acquiring a thorough practical knowledge of every branch of the business. Terms very reasonable.

SPECIMEN of "Native Wire Silver," just as taken from the mine, mounted in a scarf pin. Remarkable curiosity; very rare; only a limited number; single one \$1.50; four for \$5.00. Address, Charles F. Easton, Marysville, Mont.

THE Trade are cordially invited, when visiting New York, to call at our Office, No. 30 Union Square, and inspect our line of samples for the Spring Season.

Our MR. FRANK MAUSER will soon call on you with a full line.

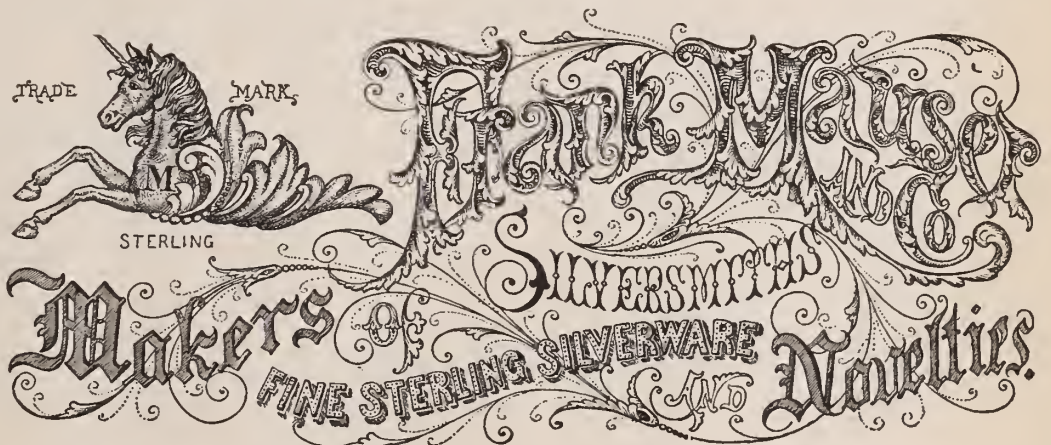

SEE OTHER SIDE.

BEING convinced that after a fair trial you will find it to your advantage to take

The Jewelers' Circular

regularly, we offer the following inducements to new subscribers:

UPON RECEIPT OF TWO DOLLARS

(the price of one year's subscription), we will send THE CIRCULAR for one year (52 numbers) to any address, and a copy of our book of **Monogram Plates**, which contains **44 Plates** or **2,112 Monograms** in all, in six different styles. Or, for

50 CENTS, WE WILL SEND

The Jewelers' Circular

For **SIX MONTHS** on trial.

Either of the blanks given below, if filled out and returned with the proper amount of money, will secure for you one of the best trade journals in the world for the time stated.

_____ 189
TO THE Jewelers' Circular Publishing Co.,
189 BROADWAY, NEW YORK.

Enclosed please find TWO DOLLARS, for which send THE JEWELERS' CIRCULAR for One Year, beginning _____ and one book of Monogram Plates.

NAME, _____

ADDRESS, _____

_____ 189
TO THE Jewelers' Circular Publishing Co.,
189 BROADWAY, NEW YORK.

Enclosed find FIFTY CENTS, for which send THE JEWELERS' CIRCULAR for SIX MONTHS, on Trial, beginning _____

NAME, _____

ADDRESS, _____

Canada and the Provinces.

A. F. Tero, of Regina, N. W. T., is moving to Lethbridge, Alberta Ter.

J. H. Nickerson & Co., of Moncton, N. B., have dissolved partnership.

Joseph Goldstein, who was an accomplice in the robbery of Singer's store in Toronto, was last week sentenced to one year.

The sympathies of the CIRCULAR are extended to R. N. Scott, for the past eight years confidential bookkeeper for J. H. Jones & Co., Montreal, in the loss of his only son.

R. & L. Watson have opened a first-class watch and clock-repairing establishment at the foot of Caledonia street, North Sydney, N. S. J. G. Cavanagh, a practical workman, will attend to all repair work intrusted to him.

D. Beatty has purchased the stock of the late Henry Ross, for whom he has been manager for a number of years. Mr. Beatty, who is a practical workman, will continue in the retail business at the old stand on St. Peter street, the style of the firm being D. Beatty, successor to Henry Ross.

Consul General Frye, of Halifax, N. S., received a letter last week from Thomas B. Myers, of Myers & Co., of St. Paul, Minn., asking him to watch for his nephew, Theodore M. Finch, who recently ran away from home with a quantity of jewelry. The runaway was supposed to have gone to Halifax. A young man answering to the description given took passage on a foreign vessel sailing from Halifax a few days ago, but there is no certainty that he was Finch.

Ocean Voyagers.

Hipp Didisheim arrived last week on *La Champagne*, Max Freund and L. Neresheimer, on the *Umbria*, and A. J. Kahn, of Kahn & Levy, on *La Bretagne*.

Edwin A. Thrall sailed for Europe on the *Majestic*, and A. K. Shiebler on the *Saale*.

Robbed While at Dinner.

CLEVELAND, O. FEB. 25th.—While Maurice Wertheimer, of 705 Woodland avenue, was

eating his dinner in a rear room off his store, a thief slipped in at the front door and stole about \$400 worth of jewelry.

The articles stolen are as follows: Eight hunting case gold watches, valued at \$100; one small guard chain, \$25; one small neck

chain, \$18; five small silver watches, \$25; five or six watches and chains, the value of which was not given.

Mr. Wertheimer thinks that much more of his stock was stolen that has not yet been missed.

A RE YOU DISSOLVING PARTNERSHIP
 RE YOU HAVING DULL TRADE
 RE YOU ABOUT TO RETIRE
 RE YOU OVERSTOCKED
 RE YOU REMOVING

?

IF YOU ARE, COMMUNICATE WITH

A. J. COMRIE,
AUCTIONEER,

Specialty of Jewelers' Sales. 16 West 125th St., New York.

CO-PARTNERSHIP.

We would respectfully announce that Mr. ALEX. REDLICH, long and favorably known to the jewelry trade, has joined the firm of **A. LUDWIG & CO.**, manufacturers of Sterling Silverware, 247 and 249 Centre Street, New York, and the firm will hereafter be known as

LUDWIG, REDLICH & CO.

DAY & CLARK,
 MAKERS OF
 FINE JEWELRY,
 BEAD NECKS AND BEAD BRACELETS,
 CURB AND LINK BRACELETS
 STRICTLY 14 KT.
 10 MAIDEN LANE, N. Y.

WATCHES.
 JOHN B. YATES,
 147 NASSAU STREET,
 NEW YORK.
 SPECIALTY:
 UNITED STATES WATCHES

Geneva Optical Co.,
 MANUFACTURERS OF
 Spectacles, Eye
 Glasses, Lenses
 and Cases.
 23 WASHINGTON ST.,
 CHICAGO.



IMPORTERS OF
DIAMONDS.

KOCH & DREYFUS,

22 John Street, New York.

JOBBER'S OF
 Watches and Jewelry.

GEORGE MALLET,

REPRESENTED ON THE ROAD BY
 HENRY HEYMAN,

LEO GOLDSMITH.

News Gleanings.

N. H. Price, Radford, Va., has sold out.

C. Pipes has succeeded Pipes & Brown, Arcadia, La.

J. W. Coatsworth, Watertown, N. Dak., is out of business.

A. W. Atwood, Bryant, N. Dak., has moved to Viola, Wis.

Frank Boehm has succeeded Boehm & Bauer, Durand, Wis.

E. G. Longcroft, Berlin, Wis., has moved to Beloit, same State.

G. A. McHenry, Chippewa Lake, Mich., has gone out of business.

H. A. Whelplay, Tacoma, Wash., has sold out to Mrs. Eva C. Boyle.

Frederick Hoffman, Madison, Neb., has sold out to Julius Hoffman.

Henry A. Burton, Charlestown, W. Va., has sold out to H. G. Knapp.

E. C. Row has moved from Osceola Mills, Pa., to Phillipsburgh, same State.

Richardson & Lineberg have succeeded Richardson & Keyes at Mt. Ayr, Ia.

H. M. Patterson, has moved from Westfield, Pa., to Newberry Junction, same State.

Geo. W. Hickox & Co. have moved from Santa Fé, N. M., to Albuquerque, same territory.

Root & Chamberlain, Marshalltown, Ia., have been succeeded by Chamberlain & Allen.

A. M. Mossman, of Hudson, Mass., has just completed a course of ophthalmology in Boston, Mass.

Louis Rochat, a skillful Swiss watch-maker, has opened a new jewelry store at San Bernardino, Cal.

Burglars entered the store of Mrs. M. E. Lake, at Nunda, N. Y., last Tuesday night, and carried off a quantity of stock.

C. E. Child is enlarging his jewelry manufacturing plant at Warren, R. I., by the addition of the entire floor above that which he now occupies.

Max Jennings, Grand Rapids, Mich., was last week relieved by burglars of eighteen or twenty silver watches and some cheap chains, valued at \$50.

Col. D. M. Cubbison, at one time proprietor of a jewelry store at New Castle, Pa., opened the Fountain House, a handsome hotel there, on March 1.

Wm. J. Eaton, Bellows Falls, Vt., has bought out M. D. Jackson's store at that place and is conducting both establishments under the name of Wm. J. Eaton & Co.

Benton Elmore has opened a new retail store and manufactory at Biggs, Cal. Mr. Elmore recently completed a model of a traction engine which he claims is a perfect success.

Col. J. M. Rutherford, the well-known auctioneer, at the close of a recent successful sale for M. Cohen, of Pittsburg, was presented by Mr. Cohen with a handsome gold-headed cane.

M. Dorenfield has moved from Bastrop, Tex., to Belton, Tex., where he has bought one-half interest in the business of J. Dorenfield. The new firm is now conducted as J. Dorenfield & Bro.

W. F. & D. A. Cooper, Bristol, Tenn., had thought their father, A. Cooper, died in the army in Georgia in 1863, till last week, when they received a letter from Louisville, Ky., stating that he was alive.

On the night of Feb. 23 a man broke in the window of William Schmalz's pawn-shop, at 781 Mission street, San Francisco, Cal., seized a tray containing forty-five diamonds, valued at about \$3,500, and disappeared.

A. Horowitz, Hudson, N. Y., who failed some months ago, has effected a settlement with his creditors on a basis of 50 per cent. 15 per cent. cash, 12½ per cent. six months' notes, and 12½ per cent. in twelve months' notes.

William Wise, of William Wise & Son, Brooklyn, N. Y., was before the Senate Committee on Commerce at Albany, last week, to oppose certain passages in the Bridge Terminal Bill, which he claims affects property owned by him.

W. E. Thoma, who opened a jewelry store at Jackson, Mich., four months ago, has temporarily given up business on account of ill-health. His stock has been shipped to Kalamazoo, same State, where he will locate when he recovers.

It is reported that a silver plating company will shortly locate in Babylon, N. Y. A factory will be erected that will accommodate about 100 hands. Twenty thousand dollars worth of the stock has been subscribed for by prominent Babylon business men.

The ladies in Toledo are giving at card parties and afternoon teas in the way of favors, jewelry such as lace pins, friendship rings and bracelets, instead of fancy articles. One lady presents as favors pins which designate the partners for the evening.

Simon & Co., Fresno, Cal., have purchased a \$25,000 stock of D. Rose at sheriff's sale and are selling the goods at auction. Sales are held every afternoon and evening. Simon & Co., recently engaged four skilled workmen for their manufacturing department.

John W. Tyler, of the firm of Tyler & Anderton, Dayton, O., has sold his interest in the business to a company consisting of J. W. Anderton, J. C. Eberhardt, and J. E. Wiefenbach. The new firm will hereafter be known as Anderton, Eberhardt & Co.

The Voigt Manufacturing Jewelry Co. have filed a certificate of incorporation at Washington, D. C. The capital stock is \$100,000, and Henry Lightwardt, C. A. Brickwedde and John L. Buckart are the trustees. The place of business is at 713 Seventh street.

Two young men who were endeavoring to sell rings on North Main street, Pawtucket, R. I., last Thursday afternoon, were arrested. The rings were of the same worthless character as have been offered there several times of late, and were good imi-

tations of gold, bearing the stamp of 18 karat. One of the men had a large stock in his possession. He was fined \$10 for peddling without a license.

M. Sutton, at Addison, N. Y., was married last week to Miss Dora Loop.

F. Sulzner, St. Augustine, Fla., has left for South Florida on a prospecting tour.

J. W. Higginbotham, Arcadia, Fla., has moved into a new store in that town.

Fred. G. B. Weihe, Ocala, recently presented to the High School of that town three hundred tablets, rules and lead pencils.

David Yellot, a jeweler of 166 Ryerson street, Brooklyn, N. Y., has began a suit to recover the estate of Charles Yellot, a wealthy Brooklynite who recently died.

On Feb. 25, on the order of J. Frank Fort, receiver for the Riley-Osborn Manufacturing Co., a sale of the plant and factory property of that company was commenced.

Clemens Hellebush, Cincinnati, O., has such a high reputation for fine and fancy clocks, that has made the trade regard him as authority for clocks in imported or American goods. It does not matter what sort of clock you want, he can furnish it. He has a very expert corps in his factory that can design any base for a clock. They have met the wants of numerous customers.

The store of William R. Bennett, 544 Federal street, Camden, N. J., was sold under the sheriff's hammer on Friday last, to Mr. Bennett's mother. The store, it is understood, will be continued under Mr. Bennett's management.

On the night of the 25th, the store of Henry Fredericks, Camden, N. J., was entered through the cellar door and \$200 worth of silverware and fine cutlery were carried off. Although electric lights lit up the front part of the store brilliantly, and the thieves must have walked boldly to the windows, the policeman on the beat professes to have been in entire ignorance of the occurrence until late in the morning. No one was captured, of course, and as this has been the eighth burglary in Camden within three days, the public is excited.

The Fine Display Tempted Him.

The show window of the store of Isaac M. Seckel, 45 Whitehall st., this city, was smashed Monday morning by Philip Redmond, of Brooklyn. Redmond had been out of employment some time, and claims to have been tempted by the array of jewelry. After breaking the glass he abstracted from the window a lady's watch, two rings and a gold bracelet. He was captured after a short run and the property was recovered.

Redmond told Captain McLaughlin, of the Old Slip station, where he was locked up, that he had committed the crime in a fit of desperation over his inability to get work. He had been meditating it for several weeks, and finally found himself unable to resist the temptation. He was remanded at the Tombs.

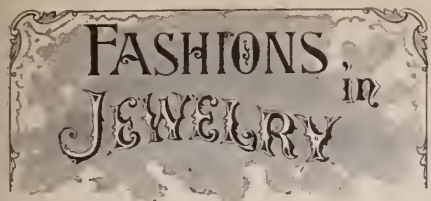

A Lady's Ramble Among The Jewelers.

China-lined silver tea-cups are the latest fad for "five o'clock" teas.

Piano candle-sticks of silver are fluted in antique style.

An exceedingly fine gold chain for the neck with a pendant encrusted with diamonds, is a favorite article of jewelry.

For ladies in mourning, are furnished necklaces of onyx beads, plain, faceted, polished or unpolished, as suits the taste of the wearer.

Double sugar basins united by intertwined handles in the centre, are designed for lump and powdered sugar.

Chatelaines in the form of fleur-de-lis, bow-knots and other designs, are attached to small watches in decorated cases, and worn as badges. The rage for jewelry is greater than before in many years.

Novelties in watches are small affairs, the backs of which are ornamented with a miniature painting framed in small diamonds or pearls.

The modern Greek coiffure now affected by many ladies, necessitates the wearing of decorative hair-pins.

Brooches run medium to small in size. Diamond spiders and lizards figure as brooches.

The opal, turquoise, amethyst and topaz, are all fashionable stones.

An original nut bowl represents, in silver, the half of an English walnut.

A unique combination is that of a choice porcelain cup resting in a silver saucer.

Quaint old Dutch glass bottles are copied in modern cut-glass decanters with silver mountings.

The newest claret jugs and loving cups afford attractive and artistic examples of the silver deposit ornamentation.

A sugar dredger that will make its appearance with the small fruits, is in form of a cornucopia, richly chased and with plain silver handle.

Carbuncles, aquamarines and similar fancy stones, somewhat rudely set in oxidized silver, please a large class of wearers by their barbaric sort of beauty.

With the present fancy for colored stones the alexandrites are naturally of frequent occurrence in jewelry. These stones are green by natural, and red by artificial light.

Cloisonné enamel clocks and candelabra to match grace the mantels of many well-furnished houses.

A novel sugar dish is that which simulates, in silver wire, a wicker hamper.

A charming moonstone brooch seen had a wreath of silver leaves.

An English production in way of a lady's purse is the usual leather affair adorned in one corner with a lucky sixpence.

An odd conception is expressed in a bon-bon box of silver, modeled after a snail.

Spring bonnets are decorated with metal arrows, daggers, serpents and other ornaments. encrusted with mock gems.

The three-row crescent brooch, in brilliants or in pearls, is a favorite.

We continue to see in the jewelers' show-cases, violins, harps, guitars, banjos and even bars of music, faithfully wrought in gold and silver, and mounted as brooches.

In table ware, the bright finish with rich chasing and fluting, is a popular combination.

Scarf pins afford a bewildering variety of designs, such as flowers, birds, animals, nautical, musical and other emblems.

Moss agates from Wyoming have been introduced in some of the new jewelry, as have also the almost ruby-red garnets from Arizona.

ELSIE BEE.

Hamilton, O., Feb. 16, 1891.

Please send No. 1 of "The Circular." When I wrote you I intended to commence with the first number in February so as to have the year complete. Don't fail to send it.

C. E. Durst.

ESTABLISHED 1841.

CARTER, SLOAN & CO.,

MANUFACTURERS OF

FINE JEWELRY,

15 MAIDEN LANE, NEW YORK.

A. CARTER, JR.
A. K. SLOAN.
C. E. HASTINGS.
GEO. R. HOWE,
WM. T. CARTER.



Factory, NEWARK, N. J.

BURDON'S · SEAMLESS.

THE · ORIGINAL
And only Genuine



AND
Perfect Seamless Filled Wires
IN THE WORLD.
Sold to all Manufactur-
ers alike.

Burdon Seamless Wire.
TRADE-MARK.

The success of the BURDON SEAMLESS FILLED WIRE, like that of all important inventions, has been followed by deceptive and imperfect imitations. For the protection of

ALL JOBBERS AND RETAILERS,

we authorize manufacturers who so desire, to affix upon the tag, card or label accompanying the articles made from this wire, this registered trade-mark owned by this Company.

The bird-on-wire is a guarantee that the goods are made from the original Burdon Seamless Filled Wire, the reputation of which has been firmly established among the best dealers for more than two years. The perfection and qualities of the Burdon Seamless Wires are always guaranteed. All Dealers (jobbers and retailers alike) should, therefore, demand goods made from the original Burdon Wire, and avoid imitations which are offered as "just as good."

BURDON SEAMLESS FILLED WIRE CO.,
109 to 119 and 127 Summer Street,
PROVIDENCE, R. I.

TELL A. BEGUELIN,
IMPORTER OF
WATCHES,

Watch Materials, Tools and Glasses,

NO. 71 NASSAU STREET,
(UP STAIRS.)

Cor. John Street, NEW YORK.

Sole Importer of Material for the

"Bijou," "Victor," "Boston," "Bristol,"
"Adelphia," "Jockey Club," "Wallingford,"
"Cesar," "Lady Racine" and "New Haven"
Watches.

AMERICAN WATCHES.

ALSO STEM WIND WHEELS.

IMPORTER OF

Full Line of **SWISS WATCHES,**

ALSO IMPORTER OF

FRENCH CLOCK GLASSES.

R. & L. FRIEDLANDER,

Wholesale Jewelers,

—AND—

JOBBER IN AMERICAN WATCHES,

Tools, Materials and Optical Goods,

65 & 67 NASSAU STREET, N. Y.

Factory, 50 BOND STREET.

Send Business Card and we will mail you our Watch and Jewelry Catalogue, No. 12,
and our Tool, Material and Optical Catalogue, No. 14.

Try our **Monarch American Mainsprings,** \$12.00 PER GROSS,
\$1.00 PER DOZEN.

POSITIVELY NO GOODS SOLD AT RETAIL.

Established 1872.

PLAINVILLE STOCK CO.

P. S. CO.

THIS TRADE-MARK REGISTERED, AND STAMPED ON ALL OUR GOODS.

BROOCHES, SCARF PINS, DROPS, SETS.

FACTORY AT PLAINVILLE, MASS.

SAMPLES AT 176 BROADWAY, NEW YORK.

DIAMOND SETTINGS.

GALLERIES.

HOLLOW BALLS, ETC.

BLANCARD & CO.,

36 & 38 JOHN STREET,

SEND FOR OUR

NEW YORK.

CATALOGUE.

NEW DESIGNS
Class-Rings and Pins

RaZZle PuZZle "Medal very satisfactory."
DaZZle "They are now beautifully made in sterling silver and gold."
"Class Rings gave splendid satisfaction"
"Received in good order, Pin, which is VERY satisfactory. We wrote yesterday for sample Class Ring and hope to get that order also."
"Goods give entire satisfaction, well satisfied"
"The young ladies are delighted with Class Rings."
"Many thanks, for rushing work ordered."
HENRY C. HASKELL,
MAKER OF FINE JEWELRY,
11 JOHN STREET, NEW YORK.

COPYRIGHT PLATES
Sent to Dealers upon request.

The Other Side of Life.

When is a timekeeper not a time-keeper? Five times out of ten.

There is a Justice in Islip, L. I., of the name of Clock. His principal business is to give time to the prisoners.

Natural philosophers who have devoted much time to studying the subject warn people to be mindful of themselves when both the hour and minute hands of the clock cover I. The clock might then strike one.

Actress' diamonds are like kisses. The oftener they are stolen the more are the owners pleased.

COLLECTOR.—How about meeting this note?
MERCHANT.—I can't do it to-day. But I'll make a note of this meeting.

OPERATIC ITEM.

MRS. BILLSDOO.—Have you ever heard "The Chimes of Normandy?"

MRS. BULLION.—No. I have not yet traveled in France.

WELL SUPPLIED WITH FIRE ESCAPES.

DRUMMER.—Have you a fire escape in this hotel?

BONIFACE.—We have ten of them.

DRUMMER.—Thought so. The fire all escaped from my room last night, and I almost froze.

SUGGESTED A SUBJECT.

The bewhiskered superintendent beamed upon the class of boys.

"Now, boys," said he, "what shall I talk about?"

"Talk about a minute," exclaimed the bad boy of the class.

BOTH BROUGHT UP WELL.

POPINJAY.—There goes a man who was brought up with a silver spoon in his mouth.

PONSONBY.—I know a man who was brought up with a dozen silver spoons in his pocket.

ALL THERE BUT NOT VISIBLE.

SILVERSMITH.—This piece, as you notice depicts in repoussé the story of Venus and Adonis.

CUSTOMER.—But I only see the Goddess' figure.

SILVERSMITH.—True enough. Adonis is chasing the wild-boar and is out of sight.

LENTEN RESTRICTION.

FLEDGELY.—As it is all over with us I wish you would return me the ring and watch I gave you.

ALICE.—I cannot give them to you until after Lent.

FLEDGELY.—But I insist upon them now.

ALICE.—You know, Mr. Fledgely, that I cannot indulge in any pleasure during this season.

TOWLE MFG. CO.,

MANUFACTURER OF



Sterling Silverware



NEWBURYPORT, MASS.: 214 MERRIMACK ST.

CHICAGO:

149 & 151 STATE ST.

SAN FRANCISCO:

220 SUTTER ST.

ESTABLISHED 1873.

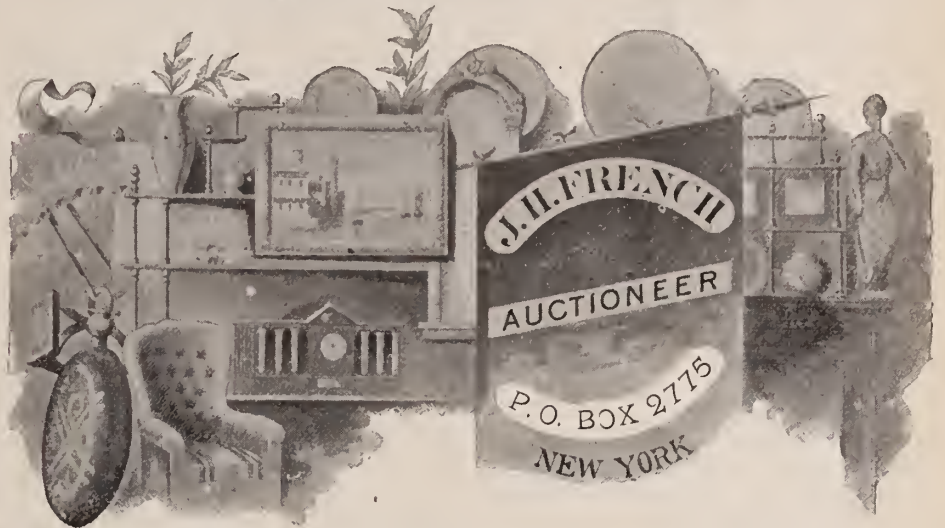

If for any reason you should desire the services of an AUCTIONEER, and will write me as to the amount of stock you have on hand and its general character, the size of your store and the number of inhabitants of your town or city, I could, from my extended experience, give you an idea of the amount of business you could expect under the circumstances, and, no doubt, be able to refer you to some one for whom I have sold under conditions similar to your own.

As a general reference, you could hardly find a wholesale jeweler who is not familiar with some of the numerous successful sales I have made.

I have made many successful AUCTION SALES, and have yet to record a failure to fully satisfy the owners. Can give you hundreds of references to that effect.

If the business should be urgent and I am myself engaged, I have two competent assistants instructed in my methods whom I could send on short notice.

Any correspondence with me will be strictly confidential in every case.
P. O. Box 2775.

NEW YORK CITY.



ONE OF THE OLDEST RESTAURANTS
DOWN TOWN.

POPULAR PRICES

Town Talk.

IN amateur athletic circles the question of awarding watches and jewelry to winners of athletic matches has been, and is still, being hotly discussed. Article IV. of the constitution of the A. A. U. asserts that an athlete to be considered an amateur must not accept for his feats any emolument whatsoever from which it is possible for him to add to his income. The amendment committee of the A. A. U. have had presented to them a resolution to limit the value of prizes for local contests to \$20, for sectional contests to \$30, and for national contests to \$40. The purpose of this resolution is to do away with the awarding of watches and diamond pins, which were often contested for solely for their value. By the adoption of the proposed amendment retail jewelers will lose a source of profit that is not to be winked at.

The public auctions at Police Headquarters, 300 Mulberry street, at which a considerable quantity of watches, diamonds and gold jewelry are often "knocked down" at one-half their commercial value, are not calculated to prove beneficial to the legitimate retail jewelry trade.

Bloomington Bros. are conducting their "great annual jewelry sale." It began on last Tuesday, when, according to their announcement, \$50,000 worth of watches,

clocks and jewelry was placed before the public. The schedule of the prices of the various lines offered was interesting as demonstrating that it is a fallacy to suppose that jewelry is a luxury meant only for moneyed people. It does not take a Gould or an Astor only to buy gold-plated earrings at 15 cents a pair, or brooches at 10 cents.

He was a facetious-minded man, and there was very seldom much method in his madness. A talk on fashions had been in progress and the subject turned at length upon fads and failures in jewelry. Said he: "Ear-rings seemed to have been somewhat unpopular for the past two or three years. Though they are gaining slowly again in favor; would it not be a fine plan for several manufacturers of jewelry to club together and present an especially fine pair of earrings each to Mrs. Paran Stevens, Miss Sallie Hargous and other shyster-de-puysters of the fashionable world. If they would accept the presents, their long army of imitators would follow in their wake, and the fashion would gradually spread throughout the entire woman race in America."

Judge Barrett in Supreme Court, last week, handed out a decision that the "Rope Act" of 1887 requiring the proprietors of every hotel exceeding two stories in height, which is not fire proof to "place or cause to be placed a rope or other better appliance, to be used as a fire escape, in every room of said hotel used as a lodging room, except the

rooms on the ground floor," does not apply to New York City. The decision was rendered on the ground that Chapter 566 of the Laws of 1887 provides a complete and thorough system for equipping hotels of the city with fire escapes from sleeping apartments.

A traveler who had seen the illustration of Major Brook's grip in a recent issue of the CIRCULAR, said: "It is evident that Major Brook's grip has made the Grand Tour. Those blemishes to outward beauty, as seen in the illustration, are not the result of indiscriminate kicks, but are the remains of posters which the hirelings of the European express and railroad companies, and bonifaces have pasted on to the valise as the Major traveled from city to city."

J. Frank Harris, who recently worked for S. G. Easterbrook, Providence, is doing a thriving business, in the corridor of the Hoffman House fashioning lace pins and brooches from seamless gold wire. He makes the trinket while the customer waits. The design is usually a given name or a word of endearment, in letters about one-half inch high.

Honesdale, Pa., Feb. 13, 1891.

I am delighted to have the Circular weekly. I have perused it from the first number to the present time, and I could not run my store without it.

W. J. Van Kenren.

"WE CONSIDER"

OUR

WEBSTER-WHITCOMB Lathe, in fact, we KNOW it is

THE

BEST LATHE MADE.

SO DO THE FOLLOWING PARTIES WHO HAVE THEM:

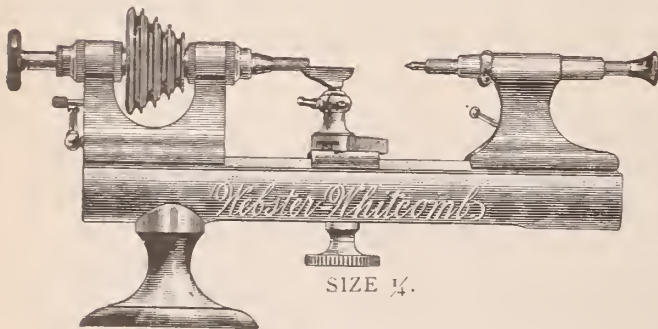

W. H. MAIRE, of Princeton, Ky., writes:

"The lathe is just at hand, and I assure you it is just what I want. It is as near perfection as they get, I think."

S. T. RUSSELL, of West Plains, Mo., writes:

"The lathe is a dandy in every respect. It gives perfect satisfaction in every respect."

OSCAR J. FUCHS, of Chillicothe, O., writes:

"My Webster-Whitcomb lathe is giving me No. 1 satisfaction, and I expect I will have to buy some more attachments soon."

GEO. E. TEW, of Seattle, Wash., writes:

"My lathe is perfectly satisfactory, and I consider it the best lathe made."

C. A. BECK, of Franklin, Ind., writes:

"I think more of my lathe than I do of myself."

TAINTOR & McALPINE, of Easthampton, Mass., writes:

"We have one of your fine Watchmakers' lathes with full set of chucks, universal head, slide rest, filing attachment, etc., and find them perfect tools."

With every lathe we send the following guarantee:—

"This certifies that the lathe marked 'American Watch Tool Co., No. —' was made by us from the best materials, on the most approved plan, and is a reliable lathe. For any defect in material or workmanship we hold ourselves responsible. Notify us promptly of any faults.

Waltham, ———"

This guarantee is also signed by the inspector who has the final inspection of the work. For several years past we have tied upon every lathe a tag of caution and instruction. All purchasers are requested to demand these documents with the lathes they buy. Remember our address:

AMERICAN WATCH TOOL CO.,

STONY BATTER WORKS.

WALTHAM, MASS



To Gild Without Battery.—Articles that do not require much handling may be gilded quickly without battery as follows: Dissolve in boiling distilled water one part chloride of gold and four parts cyoride of potash. Hand in this hot fluid the articles to be gilded, by a fine copper wire attached to a strip of zinc, scratched clear, and leave for a few minutes. They will then be handsomely gilded.

To Harden Steel.—A very fine preparation for making steel very hard is composed of wheat flour, salt and water, using, say, two teaspoonfuls of water, one-half teaspoonful of flour and one of salt; heat the steel to be hardened enough to coat it with the paste by immersing it in the composition, after which heat it to a cherry-red and plunge it into cold water. If properly done, the steel will come out with a beautiful white surface. It is said that Stub files are hardened in this manner.

Testing End Shake of Wheels.—The end-shake of wheels may be tested by taking hold of an arm of each with tweezers and lifting it. This may also be done in the case of the escape wheel, but, when the cock is slight, it will be sufficient to press gently upon it with a pegwood stick, and, releasing it observe the apparent increase in the length of pivot. At the same time ascertain that the width and height of the passage in the cock is enough to allow the teeth, when carrying oil, to pass with the requisite freedom. Holding the watch on a level with the eye, lightly raise the balance with a pegwood point several times, each time allowing it to fail. The variation observed in the space between the collet and cock will indicate the end shake of the balance staff.

To Clean a Brush.—A brush that is greasy can only be cleaned by soap and water. A new brush is prepared for use by passing an inclined cutting edge over the edge of its bristles, so as to taper them off to fine points, and to remove knots due either to hard parts or to bristles becoming united. This preliminary treatment is completed by charging the brush with French chalk, and rubbing it vigorously on a dry crust of bread until the brush can be passed over a gilded surface without scratching it. The bristles are maintained in good condition by the same treatment. Billiard chalk is also very effective for this purpose, and the greater number of cavities there are in the crust the better it will act. A burnt bone is an excellent substitute for the crust, and has the advantage of causing the brush to impart a very brilliant appearance to objects to which it is applied.

AIKIN, LAMBERT & Co.,
23 Maiden Lane,
NEW YORK,
Manufacturers and Exporters of
Fine Gold Pens, Pencils,
TOOTHPICKS, HOLDERS,
And Novelties in Silver, Pearl, &c.



THE BEST FOUNTAIN PENS.
New Assortments in **SHOW CASES** and **FANCY TRAYS** for **JEWELERS.**
Price Lists and Catalogues for intending Purchasers.



Also American and Swiss Watches.
DIAMONDS, Loose and Mounted,
Gold and Silver Thimbles,
CHAINS and **JEWELRY** in New and Staple

S. COTTLE & CO.,
MAKERS OF
FINE JEWELRY AND SILVER
NOVELTIES,
No. 86o Broadway, NEW YORK.



The
Remington

has set the copy for writing machines for 15 years.
It is to-day the

Standard

and expects in the future, as it has in the past, to lead all others in adding improvements to what will always be the true model of a

Typewriter.

Wyckoff, Seamans & Benedict,
327 Broadway, New York.

LOUIS NEWMAN, JR.

GOLD AND SILVER
Plater, Fire Gilder and Colorer.
Gilding by a New Process. Watch Cases, Jewelry and Novelties, Work stands acids, and in finish equal to Gold.
36 & 38 JOHN STREET, NEW YORK.

M. ZINEMAN & BRO.,
MAKERS OF **“DIAMANTA” SPECTACLES & EYE-GLASSES**

130 SO. NINTH STREET, PHILA., PA.

AMERICAN AGENTS FOR

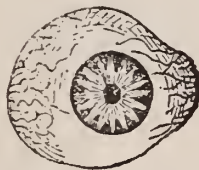

MUELLER'S · ARTIFICIAL · HUMAN · EYES,

IMPORTERS OF ALL KINDS

Opera Glasses and Field Glasses,
FOLDING POCKET OPERA GLASSES.

Sets of Trial Lenses from \$10.00 to \$75.00

✱ A SET, ✱

IMPROVED PERFECTION TRIAL FRAME.

Send for Catalogue and Price List.



WELDED CHROME STEEL AND IRON

5 PLY.

FOR BUILDING



Jewelers' Safes, Vaults, Etc.

Positively Burglar Proof, cannot be Cut, Sawed or Drilled.
OUR TRADE MARK is stamped on all our goods and we caution purchasers to avoid imitations. We are the sole manufacturers of *genuine* Chrome Steel in the United States.

CHROME STEEL WORKS,
Kent Avenue, Keap and Hooper Sts., Brooklyn, N. Y.
S. H. KOHN, PRES. C. P. HAUGHIAN, Vice-Pres. J. G. DUNSCOMB, Sec.



Something About Cameos.

THE art of gem cutting owes its origin to the old superstition that man could render himself proof against the dangers of witchcraft and human ill-will by suspending upon his neck gems and precious stones. Beside the transparent and lustrous jewels, the translucent and opaque ones were used for this purpose. Sometimes, also, ordinary rocks, and even animal productions, and metals were employed. The Greeks excelled in the art of gem cutting, which they had learned from the Orient. They adorned many dishes and vessels with cameos, and cut like cameos entire vessels of great beauty and artistic finish. One of these, the Portland vase, is now in the British Museum, in London. The ancient Romans, also, who learned the art from the Greeks, have left many pieces of a highly artistic merit. During the first centuries of Christianity, the art was followed chiefly in Constantinople, while as yet it appears not to have been introduced into the European countries. The art was carried to Italy in the fifteenth century by Greek workmen from Constantinople, where it was cultivated at the time of the Renaissance in the sixteenth century, and the art of cutting vessels from rare stones was practiced with the greatest artistic skill.

The cabinets of gems in Paris and Florence, the imperial treasure at Vienna, the treasure at Munich, and especially the Grüne Gewölbe contain a great number of these works executed by Italian, French, and German artists.

In the seventeenth century, in the Thirty-Years' War, at which time all art was paralyzed, that of gem cutting shared the common fate, and, with the exception of a spasmodic rally in the eighteenth century, not much was done in this time.

The art of cameo cutting is at present followed as an industry, chiefly in Genoa, Rome, and Paris. For forty years, the cutting of cameos was confined to Rome and Italy, but Genoa entered recently into competition, and now has thirty cameo cutters. Rome has eighty, and it is said that in Paris more than three hundred are engaged in the work.

As material for cameo cutting, besides jewels and shells, lava is now used. Certain kinds of univalves are peculiarly well adapted for cameos, since their substance consists of several differently colored layers and possesses different degrees of texture and hardness. The workman treats these shells in such a manner that the direction of the lamella of the central layer is seen lengthwise. In these cameos the central layer forms the body of the relief, the low one serves as the background, and the upper and differently colored one is used for the surface of the figure. Of shells with three layers, the cutter picks out those in which the layers adhere to each other, the central layer is thick, the different colors of the three layers differ from in color, and the inner layer is of a color that is adapted to the purposes.

In cutting, the mussel or shell is, with diamond dust and a splitting arrangement, or

with a steel knife and emery and a supply of water, cut to such dimensions as are necessary for the manufacture of cameos. These pieces are ground in suitable shapes—square round, or oval, and the rims are polished with oilstone. They are next centered upon a piece of wood, by means of which the artist manipulates the blank work while he draws upon it the figure or design with a needle. These strokes are traced afterward with a sharp-pointed instrument, with which the requisite contours are worked out. After this the work is continued with a more delicate instrument of steelwire, which is smooth and is doved at one end, and then with files and gravers, in order to remove the superfluous part of the enamel. The surface of the cameo is elaborated as much as possible with cutting instruments, since by polishing the sharp contours of the figure would be injured.

After the figure has been cut in relief, it receives a final polish with a little dry putty and a small stiff brush. Great care is required in this so that the surface may not be scratched. The cameo is then loosened from the handle and is ready for setting.

Cold Silvering.

IT happens sometimes that a jeweler or watchmaker has a silver-plated article in repair, and as not everyone can boast of the possession of a battery, he is at his wit's end how to restore the silver-plating. Let him try the following method of cold silvering:

H. A. WADSWORTH & CO.

MANUFACTURERS OF

GOLD · FILLED · WATCH · CASES,

NEWPORT, KY.

GOLD SILVERING BY RUBBING WITH THE THUMB, OR A CORK, OR A BRUSH.—The results are better than those by the so-called whitening process, but not so durable. The method is useful for repairing slight defects upon more durable silverings. It may also be employed for producing a mixture of gold and silver upon slightly gilt objects, thus avoiding the use of resist varnishes.

Make a paste by thoroughly grinding in a porcelain mortar, or with a muller upon a slab. Avoid the light, however, as far as practicable.

FORMULA I.

Water.....	Ounces	3½ to 5
White fusel nitrate of silver, or preferably, the chloride.....	"	7
Binoxolate of potash.....	"	10½
Bitartrate of potash.....	"	10½
Common salt.....	"	15

FORMULA II.

Chlorate of silver.....	Ounces	3½
Bitartrate of potash.....	"	7
Common salt.....	"	10½

Pulverize finely in a porcelain mortar and triturate under a muller upon a plate of ground glass, until there is no granular feeling. Keep the paste in a porcelain pot, or in a black glass vessel, to preserve it from the light, which decomposes it rapidly. When about to use, add a little water so as to form a thin paste, which apply with a brush or pencil upon the cleansed articles of copper, or upon those gilt by dipping; or even upon those gilt by the battery, providing the coating is thin enough to allow the copper to decompose the silver paste through the coat of gold. Allow the paste to dry naturally or with the aid of gentle heat. The chemical reaction is more or less complete, according to the thickness of the gold deposit, and the dry paste is of a pink shade, or entirely green. The salts are removed by a thorough rinsing in cold water and the silver appears with a frosted appearance, the brightness of which may be increased by a few seconds immersion in a very dilute solution of sulphuric acid, or of cyanide of potash. This silvering will bear the action of the wire brush and of the burnishing tool very well. It may also be oxidized. Should a first silvering not be found sufficiently durable after scratch brushing, apply a second or third coat. This silver is not so adhering or so white on pure copper as upon gilt surface.

For the reflectors of lanterns the paste is rubbed upon the reflector with a fine linen pad; then, with another pad, a thin paste of Spanish white, or similar substance, is spread over the reflector and allowed to dry. Rubbing with a fine and clean linen rag will restore the lustre and whiteness of the plated silver.

To Preserve Scrap.—Let the jeweler remember that economy is wealth, and is the essential thing in all jewelry repair shops. Save your scraps and filings, pick out all the scraps large enough to be picked up with the tweezers and put into your scrap to be melted. In regard to filings you should have a good-sized steel magnet to pass through your filing to remove all grains of iron and steel.

DIAMONDS.

Wm. S. Hedges & Co.,
Importers of Diamonds,

And Manufacturers of **DIAMOND JEWELRY.**
No. 170 BROADWAY,
S. E. Cor. Maiden Lane, } **New York.**
 27 Holborn Viaduct, London.



STERN BROTHERS,
"S"

A "NOVELTY" in Marquis Rings.

SEND FOR SAMPLE.

Manufacturers of Fine DIAMOND MOUNTINGS.

42 MAIDEN LANE, N. Y.

START!

R. A. Kipling

Importer of Precious Stones

31, Union Square
New-York

19, Rue Drouot
Paris

THE WALTHAM SCHOOL OF HOROLOGY,

D. D. PALMER, Teacher and Proprietor.

Best Advantages in the Country for Horological Instruction.

All branches under the personal supervision of D. D. PALMER, for a number of years in charge of the Adjusting Department of the Waltham Watch Co. **POSITIONS GUARANTEED TO APT PUPILS.** For terms and other particulars, address

D. D. PALMER,
WALTHAM, MASS.

Specialty of Difficult Repair Jobs.

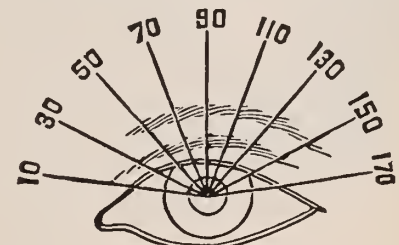

SEND TO

GENEVA OPTICAL CO.

23 Washington St., Chicago.

FOR PRESCRIPTIONS, REPAIR AND ORDER WORK PROMPTLY AT LOWEST PRICES.

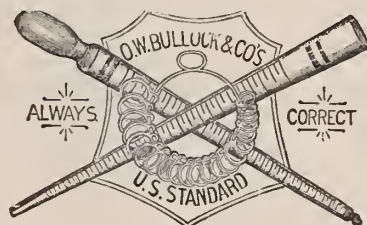

"GET THE BEST."

American Tools are the Best.

O. W. BULLOCK & CO.,

Springfield, Mass.

Manufacturers of WATCH TOOLS.

LARGEST LINE IN THE UNITED STATES.

Send 4 cents for postcard on new catalogue.

SEXTON BROS. & WASHBURN,

41 MAIDEN LANE, NEW YORK,

MANUFACTURERS OF

FINE JEWELRY,

INCLUDING A FULL LINE OF MOUNTINGS.

PROMPT AND CAREFUL ATTENTION GIVEN TO SPECIAL ORDER WORK.



Chicago College of Horology,

SUCCESSORS TO
THE CHICAGO HOROLOGICAL INSTITUTE,

IS ACKNOWLEDGED by those who have investigated
the subject to be a

FIRST-CLASS INSTITUTION,

Where those who desire to learn the art of WATCH
MAKING and ENGRAVING can obtain the

BEST PRACTICAL INSTRUCTION.

New features are continually being added. It is the
aim of those conducting the management of the
College to make it the

BEST INSTITUTION of the kind IN THE COUNTRY.

C. R. HART, *General Superintendent,*

CHICAGO COLLEGE OF HOROLOGY,

CHICAGO, ILL.

WRITE FOR PROSPECTUS.

H. H. HEINRICH,

12, 14 & 16 John St., New York.

Manufacturer of

MARINE CHRONOMETERS.

Silver Medal, Paris Exhibition, 1889.

A large stock of new and second-hand Marine Chronometers on hand. All my second-hand Chronometers are thoroughly overhauled, refinished and re-adjusted. Rented out at \$5.00 per month, payable in advance. No rent charged if bought within a certain time. Terms to suit customers. Marine Chronometers repaired and adjusted for the trade.



KEY CHAINS.

ROBT. H. INGERSOLL & BRO.,

65 Cortlandt St.,

NEW YORK.

Send for List.



TO THE TRADE.

FINE WATCH REPAIRING

BY **JOHN C. SIMMONDS,**

18 JOHN STREET, NEW YORK.
New pieces, such as Chronometer Locking Springs, Balance Staffs, &c., made in the best styles. Watches sprung and adjusted to temperature and positions.

VACHERON & CONSTANTIN,

GENEVA, SWITZERLAND.



FINEST QUALITY OF WATCH MOVEMENTS, FITTING
ALL SIZES OF AMERICAN CASES.



CHAS. LEO ABRY,

Agent for the United States and Canada.

41 and 43 Maiden Lane, - - - NEW YORK.

WATERBURY CLOCK CO.,

CLOCK MANUFACTURERS.

SALESROOMS:

10 Cortlandt St., New York,

GEO. M. VAN DEVENTER AGENT.

SALESROOMS:

114 & 116 Wabash Avenue,
CHICAGO,

H. S. PECK, AGENT.

SALESROOMS:

528 & 530 Market Street,
SAN FRANCISCO.

A. I. HALL & SON, AGENTS.

FACTORIES:

Waterbury, Conn.

123 Stockwell Street, Glasgow,

T. R. DENNISON, AGENT.

Theoretical and Practical Study of Depthing with Pinions of Low Number.

By J. Kambal, Watchmaker, etc., and Principal of the Horological School at Geneva, Switzerland.

(Continued from page 11, Feb. 25.)

THE remedy indicated in the preceding paragraph of this article of enlarging the primitive diameter of the wheel, is found not to be in accord with the principle laid down, that we ought vigorously to preserve the proportion between the primitive dimensions of the two mobiles according to the number of the teeth of the wheel and the leaves of the pinion. In following the method suggested by Camus, we would abandon a safe rule for a hazardous uncertainty. The correct mathematical calculation



FIG. 7.

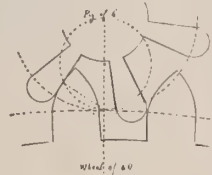

FIG. 8.

for the dimensions of the mobiles would then be superseded by an estimated approximation.

However, the defect pointed out by Camus must be admitted to exist in fact.

For the purpose of verification let us examine figures 7, 8, 9 and 10. The teeth have all the epicycloidal curve, and the width of the tooth is equal to the space. A simple glance at fig. 7 shows that a depthing in which the beginning of the action takes place so much before the line of centres, is in a bad condition and would need but very little varia-

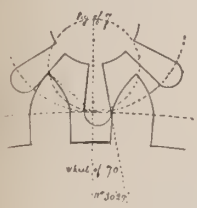

FIG. 9.

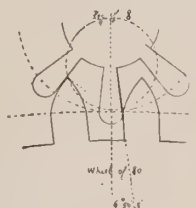

FIG. 10.

tion in their position to cause an abutting. Or before the time of the beginning of the action, the leaf and the tooth follow each other at a very short distance (fig. 8), and the smallest irregularity in the division of the wheel or the shape of the teeth might cause the contact to take place before the proper time. It is important, that such an occurrence should be avoided, and with this aim in view we propose the following:

1. Give to the teeth of the wheel the greatest possible width consistent with the proper amount of freedom in the pitching.

2. Replace the epicycloidal curve by such a curve as shall reduce the action before the line of centres to an acceptable amount (fig. 5), and which would give at the same time a sufficient space for freedom when the tooth following is entering between the leaves of the pinion (fig. 12).

Such a curve may be obtained by an arc of a circle of which, for a pinion of six leaves, the centre is located at the beginning of the opposite curve. The width of the tooth is the 0.573 part of the circular pitch.

Fig. 11 shows a tooth so formed. The action commences at a distance from the line of centres equal to a little less than half the thickness of the leaf (about 8°), of the pinion of which the whole leaf occupies 20°.

The more pronounced curve of the tooth will have the effect of insuring the proper freedom of the next tooth at its entrance, as shown in fig. 12.

Figures 13 and 14 show similar modifications of the curves of the teeth of wheels driving pinions of seven and eight leaves. The

width of the tooth for pinions of seven leaves, is the 0.564 part, and for pinions of eight leaves, the 0.549 part of the circular pitch. The action before the line of centres which for these pinions under ordinary circumstances was about 11½° and 7°, is now reduced to 5° and 3° respectively.

14. This would be very well, if by this arrangement we did not sacrifice the mathematical precision of the epicycloidal curve with its uniformity of action. The depthing will now progress with varying rapidity and consequently the transmission of power will now be irregular.

This objection is well founded and we do not pretend to construct a perfect gearing as to a uniform transmission of power by these

JAMES P. SNOW.

ESTABLISHED 1834.

CHAS. E. WESTCOTT

SNOW & WESTCOTT,

SUCCESSORS TO G. & S. OWEN & CO.,
MAKERS OF

↔ FINE JEWELRY, ↔

Lace Pins, Ear Rings, Scarf Pins, Sleeve Buttons, Sash Pins, Collar Buttons, Bracelets, Studs.

All Goods sold by us are exclusively of our own manufacture and are warranted 14 K. Fine, and stamped as such when possible.

No. 3 MAIDEN LANE, NEW YORK.

ESTABLISHED 1837.

TAYLOR & BROTHER,

Old House READ, TAYLOR & CO.,
IMPORTERS OF

Diamonds and Pearls

AND
Manufacturers of Diamond Jewelry,

360 BROADWAY, NEW YORK.

Branch Office, 1½ Maiden Lane.

21 HOLBORN VIADUCT,
LONDON.

208 KEAFNEY ST.
SAN FRANCISCO.

ROBERTSON & LEBER,

GOLD, SILVER AND

PLATINUM

REFINING.

PLATINUM SCRAPS MELTED

13 & 15 Franklin Street, Newark, N. J.

JEWELERS' SWEEPINGS A SPECIALTY.

PLATINUM FOR SALE.



THE ORIGINAL
**GOLD CROWN
FILLED RINGS.**



SECOND QUALITY.

To meet the demand for a lower priced Gold-filled Ring, we are now making, in connection with the Crown Ring a Second Quality Ring, stamped as above. WE MANUFACTURE FOR THE JOBBING TRADE ONLY. **WM. E. McCALL,** Successor to McCall & Newman, 625 Arch Street, Philadelphia.

A. N. CLARK, PLAINVILLE, CONN. } MANUFACTURER of the Celebrated

LOOP WATCH KEY.

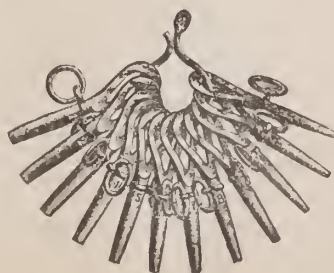

The best for the price in the World. Size of Square stamped on each Key.

Also Key Rings, Watch Case Springs, Jewelry Tools, Tweezers, Etc.

SEND FOR PRICE LIST.

SOLD BY ALL JOBBERS IN THE LINE AT MANUFACTURER'S PRICES.

means. But the same condition exists unquestionably in the depths of wheels with pinions of low number, where the teeth of the former have the epicycloidal curve.

This point requires further explanation, since it may be the prevailing impression among watchmakers that if the action in depths is uniform, the transmission of power is uniform also.

When the tooth of the wheel is in contact with the leaf of the pinion on the line of centres, the lever of power is equal to the primitive radius of the wheel, and the lever of resistance is equal to the primitive radius of the pinion. As the tooth continues to drive the leaf, the two levers are gradually becoming shorter. When the depth reaches the end of its action, Fig. 7, the tooth touches the leaf at the point *g*. The length of the lever of resistance is then equal to the distance which separates the point *g* from the centre of the pinion. As to the lever of the driving power we will find it for this position by prolonging toward the interior of the wheel the straight line perpendicular to the flank of the leaf which joins the point *g* with the point of tangents of the primitive circles, and dropping from the centre of the wheel a perpendicular on that prolonged line. The length of this perpendicular is that of the lever of power. Geometry shows that these two levers, called

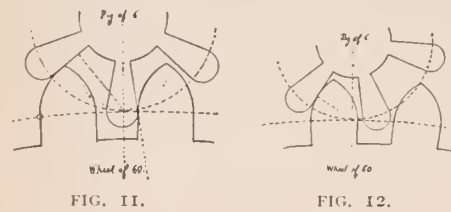

“virtual levers,” being homologue sides of two similar triangles, are to each other in the same proportion as the primitive radii of the two mobiles, from which it may be concluded that the proportion between the lever of power and the lever of resistance, not having changed the force transmitted at the end of the action, is equal to that transmitted when the points of contact of the teeth and leaves are on the line of centres.

This reasoning is geometrically true, but as we are here dealing with the organs in motion, it is well to examine them from a mechanical point of view. Then we have on the line of centres a simple touch of the tooth against the leaf. The friction being nil, the force is transmitted integrally. While in action the tooth slides on the leaf, and this sliding reaches its maximum at the end of the action. Consequently, to estimate the transmitted force at any given time of the action, it will necessitate the subtraction from the applied force of that portion of it which is absorbed by the friction of the tooth against the leaf. From this we see that the transmitted force which is at its maximum on the line of centres diminishes during its action, and reaches its minimum at the moment that the tooth leaves the leaf.

It is then an illusion to believe in the

equality of the transmission of power by means of pinions of low number. We know from observation that in small watches where such pinions *only* are used the balance changes its extent of vibration at regular intervals, notwithstanding the amount of care bestowed on the construction of the gearing.

We are inclined to believe, that the curve of the tooth formed by the arc of a circle (fig. 12), though producing a sliding motion against the leaf a little greater than the epicycloidal curve (fig. 7), will not be inferior to it as to the transmission of the motive power, and from another point of view will

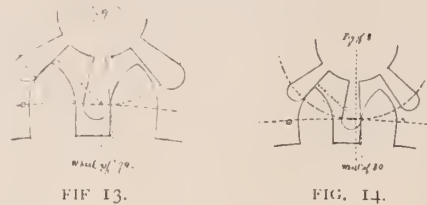

have in addition a real advantage in giving to the action of the gearing all the desirable safety.

15. This safety is appreciated without modifying the sizes of the primitive circle of the pinion, contrary to the recommendation of Camus. We can calculate the total dimensions of the mobiles with modified curves with equal precision as with the others, provided that the height of the tooth is known. This latter is equal to a fraction of the primitive radius of the pinion which it drives, and which fraction is constant for a pinion of the same number of leaves. It diminishes as the number of pinion-leaves is increased.

(To be continued.)

Watch Balance.

It is well to know that in choosing a balance it is not the weight of the balance only which should be the guide, but the momentum of the balance as well. Heretofore, the large-sized English fusee watches usually carried balances weighing as much as sixteen grains, while the weight of the balance in our best American going barrel watches is probably eight or nine grains. A balance measuring one inch in diameter, controlled by a balance spring which brings it to time, would have to be four times as heavy if it were only one-half inch in diameter, if it were to be controlled by the same balance spring as the former, because the vein of the small balance is only one-half the distance from the center, and any given point in the vein would have only one-half the distance to travel for an equal angular motion with the large balance. But the smaller balance would have double the momentum of the large balance, because momentum is weight multiplied by velocity, and if we multiply the weight of the small balance, which is four times as great as that of the large balance, by the velocity, which is one half of the large balance, we have a momentum twice as great,



The Capture of "Milky" McDonald

NEW YORK, Feb. 27, 1891.

In the notice of the last monthly meeting of the Executive Committee of the Alliance, reference was made to a letter from Robert Pinkerton stating that James, alias "Milky" MacDonald, who through the efforts of his agency had been brought back from Denver, Col., was now in jail, and the probabilities were he would get at least ten years, if not fifteen.

In the leading daily papers of Sunday, Feb. 15th the following article may be found relative to the sentence pronounced: "Hackensack, N. J., Feb. 14th.—Jas. J. McDonald, the notorious cracksman of many aliases, was sentenced by Judge Van Valen this morning to serve thirteen years at hard labor in the State prison, and to pay a fine of \$1,000 and \$800 costs."

The above sentence is due to the efforts of the Jewelers' Security Alliance.

Respectfully,
GEO. H. HODENPYL, Sec'y.

To Etch on Silver.

SANDUSKY, OHIO, Feb. 24, 1891.

To the Editor of the Jewelers' Circular:

Would you please answer in your next issue how to do etching on solid silver; that is to eat in the silver so that the letters stand out? HENRY DEHNEL.

It may be stated in general terms that the process for etching letters on solid silver is just the opposite to that in steel work, except when the letters are to be shaded. For letters, either a stencil is cut or they are painted on the finished surface with asphaltum varnish, and the other parts not to be cut or eaten by acid are covered with some protective material. The article is then dipped in dilute nitric acid, which is allowed to act to the depth required, then taken out and rinsed off and the varnish dissolved. The state of dilution varies somewhat with the atmosphere or with certain atmospheric conditions.

Another Answer to How to Clean Mercury.

PITTSBURGH, Pa., Feb. 21, 1891.

To the Editor of The Jewelers' Circular:

Please say in answer to the inquiry of Benjamin F. Mayo in last week's CIRCULAR, "How to Clean Mercury," to strain it through chamois skin, by pressing or squeezing it through the pores, two or three ounces at a time. He will find it a good cleaner of all oxidized mercury and dust, which is all that troubles his metal, unless it has become amalgamated with tin or lead from a dish or cup of the same metal. If he cannot get rid of air bubbles tell him to drop me a line.

CHAS. F. SHEIB.

Philadelphia, Pa., Feb. 12, 1891.
I received "The Circular" to-day, No. 1. Please send No. 2 as I do not wish to miss a single number.
J. W. Warnholm,



The excellent finish of CRESCENT Cases, their intrinsic value, and their wearing qualities, justify the high position which they hold among Gold Filled Watch Cases. Their unequalled popularity is a proof of superiority and a mark of appreciation.

Guaranteed for twenty years.

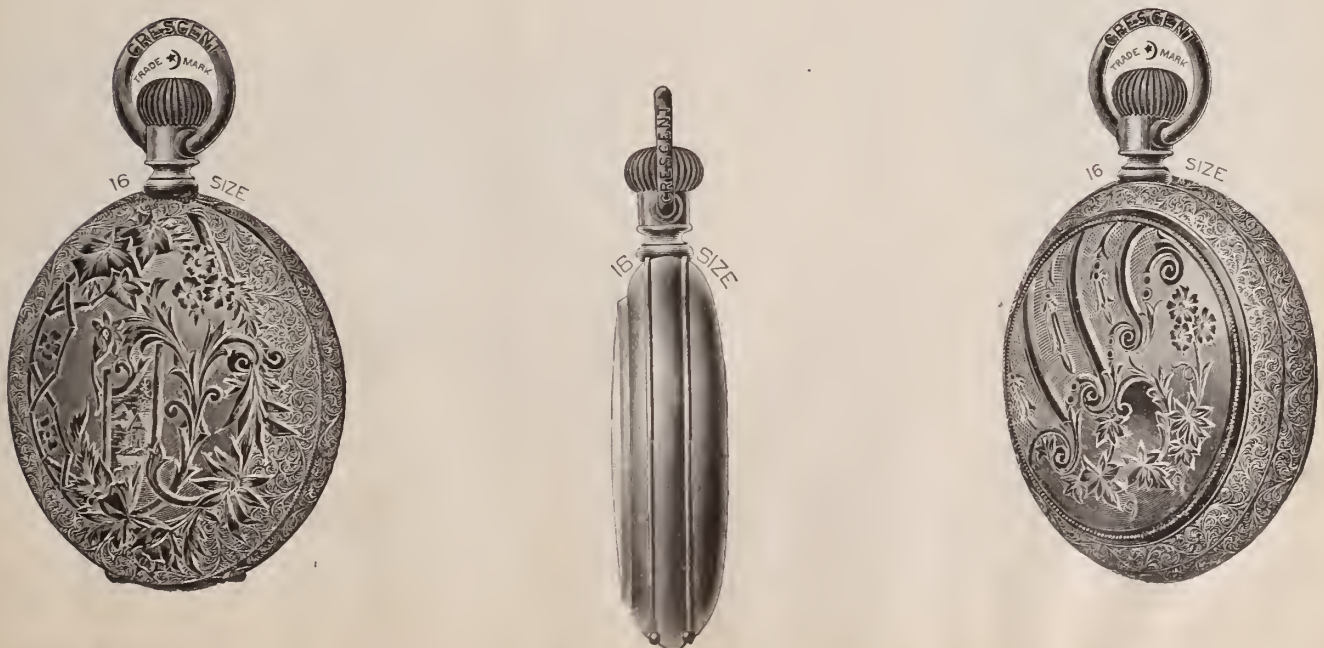

Brief History of Gold and Silversmithing.

(Continued from page 45, Feb. 18.)

PART III.

THE BYZANTINE PERIOD.

THANKS to the snarling tool, Parisian chasers were enabled to emboss vessels of almost any shape or character.

The *ressing* used in the sixteenth century was rather loosely stuck in a block, because its metal could not swing so well as that of the modern one. The artist held with his left hand the vase, in which that bent tool with its pointing end fashioned as required, had been introduced, and dealt a blow on the back end, with a hammer. This caused a bump to come out on the part of the vase resting on the snarling tool. This *repoussé* process being carried on with *ressing* variously shaped at the top permitted him to obtain all the most salient parts of an elaborate embossed work. When that was done the artist filled the vessel up with cement and chased the outside.



FIG. 16.—16TH CENTURY GERMAN EWER.

Enamel-work was at its height during the Renaissance period. But a complete description of all processes employed in that branch of art would carry us out of the special limits ascribed to this essay. Encrusted enamel-

work was chiefly executed in four different processes, known as *champlevé*, *cloisonné*, translucent enamel on relief, and *niello*. Enamel painting was done with great success by Limoges' artists. Léonard Limosin, Jean Penicaud and many others acquired a high repute in that line.

Fig. 18 reproduces a beautiful ewer decorated in that fashion, which belongs to the Basilewshi collection. The background in black enamel sets off the scenes painted in *grisaille*, or gray, slightly tinted with pink on the bare parts of the figures. We see illustrated on that ewer a passage, rather freely interpreted from the Bible. Moses, represented as a strong child, is seen in the act of striking the rock, while young women, well provided with pitchers, are waiting for the water to spring out of it. The handle exhibits white ornaments with gold touches.

To condense in a few words my impression about the Renaissance style, I may say that generally speaking it consists of splendid variations on Greek themes.

LOUIS XV. PERIOD.

A silversmith's workshop at the time of Louis XV. was a very comfortable place, whether established at the Louvre (as was the case for the *Orfèvres du Roy*) or elsewhere. Clear, roomy, well suited to its purpose, it was nevertheless in no way so elegant as some fanciful evocators of the past would lead us to believe; and if we come to reflect about it we shall easily understand that a place devoted to hard work could not very well, even in those times, be decorated like a boudoir. Our fig. 19 reproduces a part of a silversmith's workshops of that period, from a plate of the famous *Encyclopédie* published according to a privilege delivered by the king at Versailles, on the night of September 10, 1759. The windows, high and wide, were secured with iron bars, against criminal intrusions. On the left is a workman engaged in pouring melted silver into an ingot mould. The pair of tongs which he uses to hold the crucible is not different from those of the present day. An artisan is occupied in hammering a vessel into shape. His companion is carefully planishing a dish. He has covered the anvil with leather so as to obtain a neat and smooth work. Another one, at the back, is busy making an ewer; and the two workmen on the left are forging a plate of silver. The illustration shows the furnace, the bellows and the soldering lamp. The part of the workshop which the view does not show contained a great variety of implements.

We find at the *Archives Nationales*, in the inventory of the place of the celebrated

Thomas Germain, who died in 1748, all the details we require on that subject. He possessed twenty-seven anvils and like tools of



FIG. 18.—EWER IN GOLD AND ENAMEL.

all shapes, needed for the execution of the various works which he produced during his long life as a silversmith. Besides the well-known tool called the "sparrow-hawk," com-



FIG. 19.—SILVERSMITH WORKSHOP, TIME LOUIS XV.

monly used in our modern workshops, he employed *bigornes* differently bent and curved at both ends, and some moulding-blocks in iron, on which graceful rims of plates and dishes were fashioned. He had also four

vices, a draw-bench with many accessories, twenty-seven pincers, more than a hundred hammers, two draw-plates, five working-benches, etc. I see in that inventory no lathe mentioned. It is evident that Thomas Germain made all his wonderful works by processes which required very great skill; all being done by hand, with the exception of the parts that could be obtained by casting, which only had to be finished off with a *ciselet*.

To execute the varied and elaborate decoration of the reigning style, it was found necessary to make new chasing and repoussé tools, such as *mattoirs*, *frisoirs*, etc., so as to produce granular or rugged backgrounds, vermicular ornaments, *stride*, interlacements, etc.

Among the most remarkable pieces made by Thomas Germain, we may rank the silver sauce-boat (reproduced by our fig. 20) which belonged to the De Rohan family. The base, whose outlines are very elegant, represents a rocky ground with a lizard and a snail on it. From that ground spring up two vine plants that shoot several branches, loaded with grapes, and supporting a cup in the shape of a boat. The vessel, which bears on each side



FIG. 20.

the arms of the De Rohans, is most prettily decorated. The handles are light and graceful. The workmanship of that piece is absolutely perfect, both from a silversmithing and from a chasing point of view.

Juste Durèle Meissonnier, one of the most original artist-decorators of that period, designed a great many very elaborate pieces, and he has endeavored to extend beyond the limits of the possible the kingdom of the rococo style. Yet some of his works were treated with comparative sobriety. Let us mention the nave in massive silver, executed under his direction for the king Louis XV. That vessel, of a bold shape, made to contain the royal cover is very elegant and although richly decorated, it does not seem crowded with superfluous details.

To Alloy Aluminum.—Aluminum alloyed with a small percentage of silver loses much of its malleability, but with five per cent. of silver it can be worked well, and takes a more beautiful polish than the pure metal. With three per cent. of silver it is very suitable for instruments for scientific work, being harder and whiter than the pure metal, and is not tarnished even by sulphuretted hydrogen. With a small amount of silver it appears very suitable for scale beams, and is frequently used for this purpose. The alloy, containing five per cent. of silver, has often been suggested for coin of small denominations, as it is hard, and retains its lustre in handling.

A. WITTNAUER,

30 MAIDEN LANE, * NEW YORK.

Manufacturer and Importer of

WATCHES

LONGINES,
AGASSIZ
AND
MONARD.

* MOVEMENTS FITTING ALL SIZES AMERICAN CASES. *

THOROUGHLY ADJUSTED TIMEKEEPERS FOR RAILROAD USE.

Also, a very complete line of Accurate Timing and Repeating
Watches in Stock.

W. ROSENTALL,

Manufacturer of
SILK VEST CHAINS,
79 NASSAU STREET, NEW YORK.
Send for selection Package with reference.

ELGIN HOROLOGICAL SCHOOL
ELGIN, ILL.
 **SEND FOR CIRCULAR.** 
Repairing for the trade. Repair price list free.

WE MAKE FOR YOU TO SELL

The following lines, all of the best stock and made by the finest skilled workmen. F. & B. stamped on our cards, tags, etc., means that we know what we are about when we guarantee our goods:

Ladies' and Gentlemen's Chains that are right; will wear ten years.

Locketts and Charms in endless variety.

Bar Pins and Cuff Pins, fine in quality and cheap in price.

Sleeve Buttons, "The Mount Hope" the best in the world.

Chain Mountings for Hair and Silk Chains.

Bracelets, Curb with padlock or snap, Polished plain.

Roman plain chased bright, chased Roman, also silver oxidized.

Stanley, Jefferson and Washington Bracelets in solid silver.

Glove Buttoners, the interlocking.

Scarf Pins, Jersey Pins, Bangles, Earrings, Bead Necks,

Neck Chains and Garters.

FOSTER & BAILEY, Providence, R. I.

LOOK OUT FOR BIRTHDAY RINGS,

IN

Handsome · Novel · Window · Tray,

(Patented.)

M. B. BRYANT & CO.,

10 Maiden Lane, New York.



A. KICKERL. C.A. STIEHLE.
RICKERT & STIEHLE,
MANUFACTURERS OF
GOLD CHAINS,
SWIVELS AND SPRING RINGS.
Chain Repairing a Specialty.
13 & 15 Franklin Street, NEWARK, N. J.

A. J. GROENMAN & CO.,
DIAMOND CUTTERS,
80 Nassau Street,
NEW YORK.
SMALL MELEE A SPECIALTY.

LEWIS BROTHERS,
Easter Novelties in Silver,
41 Maiden Lane, N. Y.

EZRA KELLEY'S Famous Watch, Clock and Chronometer Oils,

RECEIVED AT THE
EXHIBITION UNIVERSELLE, PARIS, 1889.

The only Award of Merit given to Manufacturers of American Oils

It is to the interest of every Watchmaker to use in his work the *Best Oil* obtainable, regardless of cost, Mr. Kelley's claim to be the foremost manufacturer of Oils, giving the best results, is not based upon his own assertion, but is founded upon the fact that wherever his Oils have been exhibited in competition with other makes, subject to an examination of experts, they have received the highest *Award of Merit*.

For sale by all the Leading Jobbing Houses.

HENRY GINNEL & CO.,

GRIMSHAW & BAXTER, EUROPEAN AGENTS,
35 GOSWELL ROAD, LONDON, ENGLAND.

GENERAL AGENTS,
31 Maiden Lane, NEW YORK

BEST and CHEAPEST DEVICE FOR MAILING

All Mailable Matter at Cheap Postage.

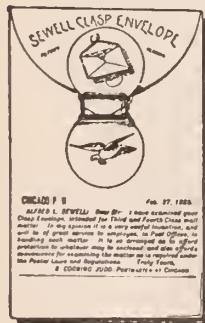

For mailing Trade Catalogues, Samples, Parcels of DRY GOODS, WOOL, YARN, COTTON, SEEDS, GROCERIES, PHOTOGRAPHS, DRUGS, WHEAT, FLOUR, GLOVES, LACES, RIBBONS, CALENDARS, SAMPLE CARDS, and all other 3rd and 4th class mail matter, is

SEWELL'S PATENT ENVELOPE CLASP,

(Patented in America and Europe.)

WHICH FITS ON **ANY** ENVELOPE IN THE MARKET.

In a moment it turns any envelope into a CLASP ENVELOPE. It is made of tough sheet brass. Anybody can put it on, as it is most convenient, and adjusts itself to a package of any size or thickness. It is endorsed by Postmasters.

We also make Envelopes, all sizes and kinds.

SAVE MONEY, and GET THE BEST, by writing for samples and prices to the

CHICAGO ENVELOPE CLASP CO.,
210 South Water St., CHICAGO, ILL., U. S. A.

ENVELOPES

FOR JEWELERS' AND OTHER TRADE CATALOGUES.

Recent Patents

Issue of February 24, 1891.

DESIGN No. 20,532. MATCH OR ASH RECEIVER. HENRY L. LEIBE, Newark, N. J.—Application filed January 20, 1891. Serial No. 378,478. Term of patent 3½ years.

TRADE MARK. 19,079. WATCH MOVEMENTS AND CASES. BYRON L. STRASBURGER & Co., New York, N. Y.—Application filed January 24, 1891. Used since March 10, 1889. "The word 'Silverex.'"

TRADE MARK No. 19,099. ARTICLES MADE WHOLLY OR PARTLY OF SILVER. DANIEL LOW, Salem, Mass.—Application filed January 5, 1891. Used since July 1, 1890. "The pictorial representation of a witch-like female figure."

446,915. DIE STOCK. AND DIE JAMES. S. FLETCHER, Rogers Park, Ill.—Filed May 3, 1890. Serial No. 350,460. (No model.)

446,916. COMBINED PERPETUAL CALENDAR AND TIME-CARD. CASSIUS M. HAMILTON, Chicago, Ill.—Filed Dec. 8, 1890. Serial No. 373,966. (No Model.)

The combination, with a card or metal sheet having perforations therein to show calendar names and numbers, of a series of rotary disks bearing said calendar names and numbers secured to the back of said card, and a spring in operative proximity to said disks for placing the same under frictional tension, substantially as shown and described,

446,933. DEVICE FOR KNURLING THE SURFACES OF METAL ARTICLES. GEORGE F. SIMONDS, Fitchburg, Mass.—Filed Aug. 25, 1890. Serial No. 362,975. (No model.)

446,934. MAKING ROLLED FORGINGS NON-CIRCULAR IN CROSS-SECTION. GEORGE F. SIMONDS, Fitchburg, Mass.—Filed Aug. 25, 1890. Serial No. 362,976. (No model.)

446,939. MACHINE FOR FORMING SHEET METAL LATHING. JOHN WEICHHART, San Francisco, Cal.—Filed July 15, 1890. Serial No. 358,821. (No Model.)

446,967. ELECTRIC TIME-LOCK. MALON I. FLOWERS, Springfield, Mo., assignor of two-thirds to James E. Jones and C. W. Price, both of Oklahoma City, Oklahoma.—Filed May 5, 1890. Serial No. 350,609. (No Model.)

447,105. INDEPENDENT ELECTRIC CLOCK. WALTER J. DUDLEY, Everett, Mass.—Filed Oct. 18, 1890. Serial No. 368,592. (No model.)

447,128. BIFOCAL SPECTACLES. GODFREY H. CLINE, Jersey Shore, Pa.—Filed Sept. 17, 1889. Serial No. 324,210. (No model.)

In bifocal spectacles, the combination of long-focus or distance lenses provided with notches in their lower inner or nasal edges, having their axes approximately parallel, and short-focus or near-view lenses arranged within the said notches at an angle to the plane of the long-focus lenses, with their axes convergent to a point in the plane of normal vision, the said near-view lenses being placed with one horn of the lens at the lower temporal edge, and the other horn at the middle nasal edge of the spectacles, so that a line drawn from one horn to the other across the lens will be the axis upon which the said lens is rotatable, the said upper or distance lenses being beveled on the lower curved edges, so as to allow them to receive the upper edges of the lower or near-view lenses at the aforesaid angle to their planes, all substantially as described.

HAVE YOU TAKEN YOUR INVENTORY?

HAVE YOU REMEMBERED? —Old gold or silver? If so,
HAVE YOU REMEMBERED? —That we pay 4 cents per kt. for gold and highest market price for old silver.
HAVE YOU REMEMBERED? —On hand a collection of old plated jewelry filings, sweeps, etc., or a lot of old jobs, which have been on hand for years, with no likelihood of being called for.
HAVE YOU REMEMBERED? —A lot of old style and unsalable jewelry on hand? If so, it would be good policy to dispose of same, convert the proceeds into an article that you would probably turn over several times, besides give your stock a nice, clean appearance.
OUR PLAN —Immediately on receipt of shipment, we will remit by cash or draft (as desired). If our offer should not prove satisfactory, we will return consignment in exactly same condition as received and pay all charges. By this arrangement you are absolutely safe, as it is no sale unless our offer should prove satisfactory, and you run no more chances than if you were disposing of same right over your counter. —Send for our little book giving pointers on testing and buying gold and silver. Mailed free on application.

GOLDSMITH BROS.

Gold and Silver Refiners and Assayers,
 63 & 65 WASHINGTON ST., CHICAGO, ILL.

Columbus, Ga., Jan. 10, 1891.
 Dear Sirs: Yours of the 7th inst. to hand, containing check for \$29.88. All satisfactory. Accept thanks.
 Yours truly,
 C. M. KINSEL.

Denison, Tex., Jan. 6, 1891.
 Goldsmith Bros., Chicago, Ill.
 Gents: Your draft of Jan. 3, '91, came to hand this day. Amount very satisfactory, (\$112.93).
 Very Respectfully,
 B. W. MERRILL.

Los Angeles, Cal., Jan. 6, 1891.
 Messrs. Goldsmith Bros., Chicago, Ill.
 Gentlemen: Your favor duly to hand, containing check for \$176.64, which is satisfactory to us.
 Yours,
 J. F. GRANAS & CO.

Little Falls, N. Y., Jan. 12, 1891.
 Dear Sirs: Your favor of Jan. 9 received, which is satisfactory. Respectfully,
 ANDERSON & HOUGHTON.

Keokuk, Iowa, Jan. 3, 1891.
 Gentlemen: Accept thanks for check for \$133.50 in settlement for old silver.
 Yours Resp'y,
 T. R. J. AYRES & SONS.

Decatur, Ill., Jan. 19, 1891.
 The check for \$65.45 is all satisfactory.
 O. E. CURTIS & BRO.

4 Centre Ave., Pittsburgh, Pa.
 Gentlemen: \$54.32 received for old gold. Thanks. Am satisfied beyond expectation.
 Respectfully,
 H. SCHEINMAN.

Milwaukee, Wis. Jan. 23, 1891.
 Gents: Your favor of yesterday, inclosing check for \$205.80, to hand, which is very satisfactory.
 Yours truly,
 C. PREUSSEK JEWELRY CO.

St. Cloud, Minn., Jan. 2, 1891.
 Gents: Your check of \$12.01 is very satisfactory, more than we expected to get. Many thanks.
 Respectfully,
 GEO. R. CLARK & CO.

Moberly, Mo., January 2, 1891.
 Goldsmith Bros.
 Gents: Your express order for old gold received. Same satisfactory. I get a great deal of old gold and silver, and have sold same in New York and Philadelphia, but have never received what I thought full value until I commenced sending to you. This is my ninth shipment to you.
 Respectfully,
 A. F. SEELAN.

JEWELERS seeking the latest ideas in Cut Glass are invited to call and inspect our new pattern,

"THE AVON,"

pronounced by connoisseurs the handsomest ever placed on the market.

FACTORY,
 HONESDALE, PA. T. B. CLARK & CO.,
 53 Park Place, New York

MUSICAL JACOT & SON,
 298 Broadway,
 New York
 Send for Catalogue.
BOXES.
 Musical Boxes Repaired.

GILBERT T. WOCLOM,
BLACK MAKER OF
 JEWELRY. Pearl Ornamented
 GOLD MOUNTED. **ONYX** and Plain
 32 & 34 John St. New York City.

A. PINOVER & Co.,

IMPORTERS OF

DIAMONDS

AND



Manufacturing Jewelers,
 25-29 ANN STREET,
 Cor. Nassau Street, NEW YORK.
 Novelties in Diamond Mountings.

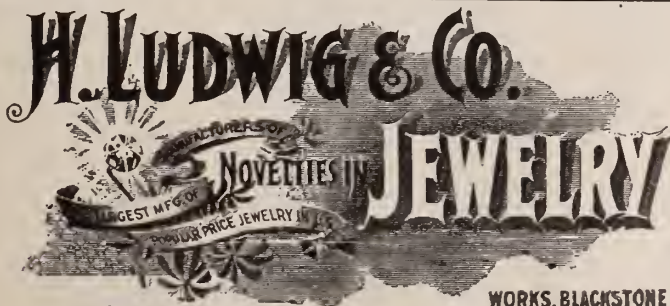

NEW YORK OFFICE,
 PRESCOTT BUILDING,
 ROOM 40. SAMPLES ONLY.

WORKS, BLACKSTONE & GAY STS.
 TAKE PRAIRIE AVE CAR

Providence, R.I.

THE RYDER & DEARTH

Fine Commercial and Copper-Plate Printers.

A Specialty of
 Jewelers' Printing, Cuts and Electrotypes.
 Headquarters for JEWELERS' CARDS.
BEST WORK, PROMPT DELIVERY, LOW PRICES.
 No Order Too Large! None Too Small!
 146 Westminster Street,
 PROVIDENCE, - RHODE ISLAND.



B. & W. B. SMITH,

220 West 29th Street, New York City.

The following Stores, Offices, etc., IN NEW YORK CITY are fitted entire or in part by B. & W. B. SMITH:

Gorham Mfg. Co.,
Whiting Mfg. Co.,
Meriden Britannia Co.,
Reed & Barton,
Meriden Silver Plate Co.,
Simpson, Hall, Miller & Co.,
Derby Silver Co.,
Rogers & Bro.,

Wilcox Silver Plate Co.,
J. B. & S. M. Knowles,
Pairpoint Mfg. Co.,
American Waltham Watch Co.,
Theo. B. Starr & Co.,
Camerden & Forster,
Black, Starr & Frost,

Chas. W. Schumann,
London & Manchester Plate Glass Co.,
Fairbanks & Co.,
Rogers, Peet & Co.,
Redfern,
Park & Tilford,
Miller & Bros.,
E. M. Gattle,
Wm. Kirkpatrick,

Howard & Co.,
F. M. Whiting & Co.,
Wallace & Sons,
J. H. Johnston,
Goldsmith & Co.,
Hamann & Koch,
Linherr,
Engle, Heller & Co.,

Dueber Watch Case Co.,
Jaques & Marcus,
Wm. Moir,
Dominick & Haff,
Mitchell, Vance & Co.,

Stern Bros.,
Macy & Co.,
Ridley & Sons,
Amasa Lyons,
Yandell & Co.,
Caswell & Massey,
Theo. A. Spear,
Dempsey & Carroll,

Huyler & Co.,
Wallace & Co.,
Monopol Tobacco Works,
Samuel Budd,
Thomas Miller & Sons,
C. D. Jones & Co.,
Robt. Dunlap & Co.,
Youmans,
N. Espencheid,

Chas. P. Murphy,
Gotthold & Co.,
Nathan Mfg. Co.,
Franke & Co.,
Simpson, Crawford & Simpson,
Gunther's Sons,
Lichtenstein & Son,

Museum of Natural History,
Ladd & Coffin,
Metropolitan Museum of Art,
John Mason,
Tiffany & Co.
Benj. S. Wise,
J. Alexander,
Aitkin, Son & Co.,

Baldwin & Co.,
Brooks' Bros.,
Casperfield & Co.,
Middletown Plate Co.,
Meriden Cutlery Co.



S. P. HOWARD,
Gold and Silver Assayer,
Refiner and Sweep Smelter,
8 & 10 JOHN STREET, NEW YORK.
Smelting and Refining Works,
28, 30 & 32 Cumberland St., Brooklyn, N. Y.
Specialties: Sweepings, Gold, Silver and Platinum.



NEW! NATTY!! NOX-ALL!!!

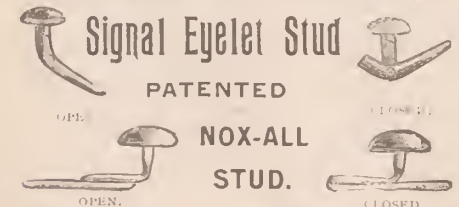

Made in Gold, Silver, Gold Fruits and Rolled Plate. E. S. 10
adjusted. "Send for Approval Packages."

J. A. FLOMERFELT & CO.,
MANUFACTURING JEWELERS,
177 & 179 Broadway, - New York.
Branch Offices: { 78 Monroe Street Chicago.
{ 145 Palace Hotel San Francisco.

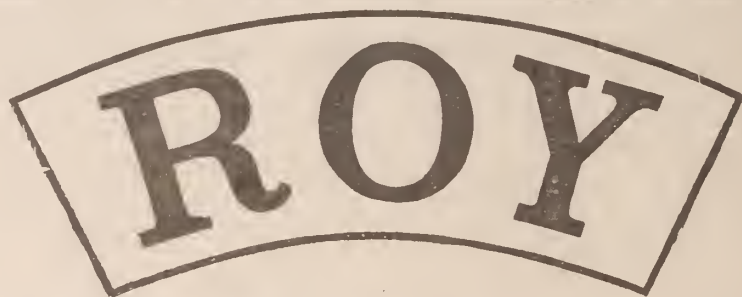

S. F. MYERS & CO., Wholesale Jewelers.

EVERYTHING
THAT
PERTAINS
TO THE
JEWELRY TRADE.
22
DEPARTMENTS.



WE REQUIRE
AND OCCUPY THE
LARGEST
SALESROOMS
IN OUR LINE.
4 STORES.
GROUND FLOOR.

48 & 50 Maiden Lane and 33 & 35 Liberty Street, New York.
CONSULT OUR MAMMOTH CATALOGUES.

Subscribe for THE JEWELERS' CIRCULAR.

COMPARE ALL OTHER
GOLD FILLED CASES
WITH THE CELEBRATED
CROWN

LION, EXCELSIOR
HAND ENGRAVED CASES
MADE BY
H. MUHR'S SONS

EXCELSIOR



Entered at the Post Office in New York as second-class matter.

VOL. XXII.

NEW YORK, WEDNESDAY, MARCH 11, 1891.

No. 6.

MAIDEN LANE IN 1849.

IN continuation of the article on Maiden Lane in 1849, which began in these columns three weeks ago, THE CIRCULAR this week presents a print of the first five houses on the south side of the street, beginning at Broadway. On Feb. 25 a cut of the buildings from No. 1 to No. 11 inclusive was

residents in 1849 was a Mrs. Sistaire, who presided over a select boarding establishment, patronized by a dozen merry young jewelry clerks and apprentices. In those days, nearly all the jewelers engaged in business about Maiden Lane resided within two or three blocks of their offices, and the

hours many jewelers were in the habit of congregating there and discussing trade matters while the smoke from their cigars filled the small place like a London fog.

Stout & Hyatt were also tenants in this building. The firm were engravers on fine jewelry. They engaged almost a monopoly

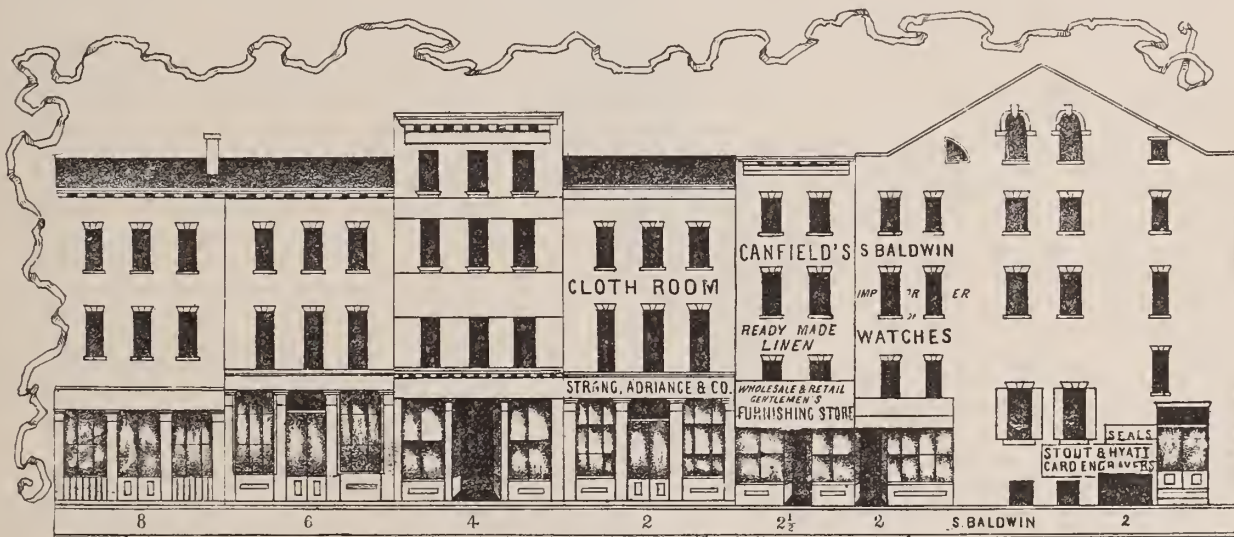

published, and on March 4, the structures from No. 13 to No. 27 inclusive were shown and spoken of.

The first building shown in the cut above was a frame and brick structure which, at the time of which we write, was considered antiquated and behind the times. When and by whom it was built it is impossible, at this late day, to discover, but information derived from various reliable sources establishes the fact that its owner had originally erected it for an "uptown" residence, and that for many years it was used as such. Among its

thoroughfare did not present the deserted appearance after nightfall that it does today.

The only jeweler in the building in those days was Samuel Baldwin, one of the pioneer watch importers of New York. Mr. Baldwin was an old man in 1849, and enjoyed the entire confidence of the trade. He had an extensive business, and his opinions on trade topics, which were seldom expressed, were noted for their sagacity.

J. Henriques occupied a cigar store on a level with the street, and during the noon

on that branch of the business, but after moving to the corner of Broadway and Murray st. financial complications caused them to separate, Mr. Stout going to California, where he settled in business. Knock & Childs, tailors, and Strange, Adriance & Co., dry goods merchants, were the other firms who occupied business offices in the building. The former subsequently moved to Warren st. and Broadway. At a later day the property was purchased by Mr. Palmly, a dentist, who erected the present structure bearing his name.

D. W. Canfield, gentlemen's furnisher, occupied the store at No. 2½.

At No. 4, W. H. Smith & Co. were located. The firm dealt in hardware and, like Francis Tomes & Sons, afterwards Tomes, Son & Melville, who were in the same business at No. 6, they subsequently did an extensive business in English cutlery and silverware. The latter firm was erroneously stated last week to have succeeded Melville & Co., who were located at No. 17.

Horstmann Sons & Ducker made a formidable display of military goods at No. 8. Their show windows were the attraction of all country visitors, who generally showed the greatest interest in the many classes of goods exhibited.

Story of a Desperate Crime Revived

NEWARK, N. J., March 7.—Andrew Conners who is at present confined in State's prison at Trenton, is endeavoring to obtain a pardon from Abbett. This statement would not attract more than casual notice, were it not for the fact that Conners is the man who attempted to rob Traphagen's jewelry store in 1881, for which he was sentenced to thirty years' imprisonment.

The crime excited widespread interest at the time of its commitment. On July 5, 1881, about 4 o'clock in the morning, Conners with the aid of several confederates, drilled a hole in Traphagen's immense safes through which they poured dynamite. To avoid suspicion when the explosion should occur, one of his "pals" had purchased an immense fire-cracker and stood in front of the store with it. This and the charge of dynamite were fired at the same instant and the explosions were simultaneous.

The safe was blown into fragments, some of which flew through the floor and ceiling. Despite the burglar's precautions, they were discovered by the tenant on the second floor, who summoned a squad of police. Conners' confederates, darting past the very door of Police Headquarters, on William st., and running through an alley immediately adjoining, escaped to the grave-yard in the rear. Conners, who pursued the same way of retreat, rushed into a factory on Halsey st., knocked the watchman down, beat him into unconsciousness, and then stowed him behind a pile of boxes. He discarded his own clothes and donned those of the watchman. He then with the aid of the latter's lantern, coolly passed through the factory, inspecting here and there.

The police reaching the place, found the watchman and then examined Conners whom they arrested on suspicion; he fought desperately to escape, and twenty or thirty shots were fired. He was overpowered, tried and convicted, as told above.

Phil Herbert, of Murphysboro, Ill., is said to have made a good deal of money during the past year. The Mobile & Ohio Railroad Company's shops gave the town a little boom, and Mr. Herbert, by strict attention to business, captured trade.

The Dueber Works to Resume Active Business.

CANTON, O., March 5.—The raising of the assignment of the Dueber Watch Case Manufacturing Co. was indeed good news to the citizens of Canton. While the force of employees has not been materially increased as yet, it is claimed that within a very short time the works will be running as large a force as before the assignment. It is an open secret that the relations of John C. Dueber and his assignee, Howard Douglass, of Cincinnati, are strained. Assignee Douglass put in a claim for \$20,000 for services rendered and even after the Probate Court cut this down to \$12,000, Mr. Dueber was not satisfied.

Yesterday two papers of considerable import were filed in the recorder's office of Stark county. The first was a deed of conveyance from Assignee Douglass transferring the Dueber Watch Case Company's property back to its original owner. The second was a mortgage deed in trust for the creditors of the company. The documents set forth that at a meeting of the stockholders held at Cincinnati, Feb. 27, a resolution was adopted to the effect that the Board of Directors of the company be authorized and directed to cause to be executed three hundred bonds in the sum of \$1,000 each, and to secure the same by a mortgage on all the property of the company. The amount of the bonds is payable at the Union National Bank, Cleveland, March 1, 1896. The bonds bear 6 per cent. interest. The mortgage is made out to E. H. Borre, of Cleveland, A. B. Champion, of Cincinnati and W. A. Lynch, of Canton, as trustees for the creditors, and is signed by J. C. Dueber, President and W. A. Moore, secretary.

The three trustees named above arrived in Canton, Tuesday, and since that time have held three conferences with the Canton Board of Trade, which body guaranteed \$98,000 to pay the claims of C. D. Rood shortly after the assignment was made. It is impossible to ascertain the object of these conferences. Members of the Board of Trade deny that any startling developments are to be expected through the meetings, and say that the trustees are in session arranging for starting the works. When pressed for further information, all the members declined to talk, saying it is private business.

Changes in The Jaccard Watch and Jewelry Co.

KANSAS CITY, Mo., March 4.—J. R. Mercer has resigned the position of treasurer of the Jaccard Watch and Jewelry Co., and severed his connection with that house. He will shortly open business for himself at 10 E. 11 st. He has leased a small salesroom and the two floors above it and will make a specialty of diamonds and fine goods; he will also do copper and steel work.

Mr. Mercer has been with the Jaccard Co. since the house opened two years ago. The stock for the new store will be bought this month, and everything will be ready for the doors to be opened April 1.

The directors of the Jaccard Co. are holding their annual meeting to-day. James Martin and W. S. Simpson of St. Louis are in attendance, and D. C. Jaccard, of the Mermod-Jaccard Jewelry Co., of that city, is here as a stockholder. The resignation of Mr. Mercer has been accepted, and R. J. Gilbert has been elected in his stead. The following officers have been chosen: President, Eugene Jaccard; vice-president, W. S. Simpson; treasurer, R. J. Gilbert; secretary, Walter M. Jaccard; directors, Eugene Jaccard, W. S. Simpson, James Martin, W. M. Jaccard and R. J. Gilbert.

C. G. Hall's Schedule.

HARTFORD, Conn., March 6th.—The schedule of the assigned estate of C. G. Hall has been filed in the Probate Court. The total amount is \$1,079.16. The assignee is Uriah Case.

The jewelers who are creditors are as follows: Kuhn, Doerflinger & Co., New York, \$301.50, Lewis Kaiser & Luthy, New York, \$48.97, A. Lounsbury & Son, New York, \$67.50, H. E. Oppenheimer & Co., New York, \$54.03, M. Fox & Co., New York, \$52., Henry Cowan, Boston, Mass., \$150., Maccavi & Burlingame, Providence, R. I., \$6.61, and H. F. Carpenter, Providence, R. I., \$580.

The schedule of assets shows \$522.35.

The Missouri Onyx Again Claims Attention.

ST. LOUIS, Mo., March 6.—G. H. Reynolds, of Rutland, Vt., has been in the city for several days in consultation with J. F. Leighton, president of the Providence Jewelry Co., in regard to the development of the Missouri onyx caves in Pulaski and Crawford counties. This is Mr. Reynolds' second trip West in this connection. Several weeks ago he took back with him to Vermont a large number of specimens of the Missouri onyx, being convinced that the flaws and rough surfaces, which appeared on the mineral after treatment by the local lapidaries were occasioned by poor work on the part of the polishers, and that the quality of the onyx would become manifest when properly treated.

Mr. Reynolds has brought the finished stones, and a CIRCULAR reporter who examined the display at the office of the Providence Jewelry Co. found after careful observation that the Missouri stone will bear comparison with the Mexican and California specimens carried in stock by the company, and which is made up into clock cases, table tops, and the like.

Mr. Leighton says that the supply is enormous; he believes that his company have secured a bonanza. This opinion is expressed also by Mr. Reynolds, who is preparing to move his entire plant from Rutland to St. Louis; he is at present engaged in negotiating terms with Mr. Leighton. He says that the negotiations have gone far enough to warrant the announcement that he will

TRADE

SEAMLESS

MARK.

GOLD · FILLED · CHAINS.

ON ACCOUNT OF

THE great popularity of the chains made exclusively by us for the past three years, the air has been FILLED and the paper of the various Jewelers' Journals COVERED with the word "SEAMLESS" which has been and is our trade mark.

We never had such a boom in our business as we have had since our friends commenced to advertise our goods.

We have only a word to add, and that is we make and sell the

ORIGINAL AND GENUINE

SEAMLESS GOLD FILLED CHAINS.

In addition to the word SEAMLESS and for the protection of our customers we place upon each Chain a tag bearing the following trade-mark :



Which is affixed by authority of its owners, as a guarantee that the Chains are made from the Burdon Seamless Filled Wire.

<p>BOSTON OFFICE, 6 WINTER STREET, In charge of I. W. STELLE.</p>	<p>NEW YORK OFFICE, 17 Maiden Lane.</p>	<p>PACIFIC COAST AGENCY, WM. E. PETTES & CO., PHELAN BUILDING, SAN FRANCISCO, CAL.</p>
--	--	---

Address all communications to

KENT & STANLEY,
PROVIDENCE, R. I.

bring his plant to St. Louis, and that he will employ from 75 to 100 men in the work here.

The properties owned by the company which Mr. Leighton has organized cover 520 acres in Pulaski Co. and 232 acres in Crawford Co. The onyx is found in caves, the existence of which has long been known to the people living in that section, but the stone was not believed to be of much value. The country people spoke of it as "mighty pretty stuff to make tombstones of," but no one seems to have realized its enormous commercial value, which is now clearly demonstrated by Mr. Reynolds in the magnificent display, comprising several hundred specimens, which he has worked up at Rutland and spread before the public gaze in St. Louis.

Since the arrival of Mr. Reynolds in this city, the importance of the find is beginning to be understood by the natives, and Mr. Leighton is besieged with offers from farmers who have found "pretty stones" on their land, and are convinced that it is onyx. Mr. Leighton's judgment, however, appears to have been remarkably good in the first place, and he believes that he covered the ground pretty thoroughly and secured about everything of value in the onyx line in that section of the State, before the excitement set in.

An Ithaca Dealer Succumbs.

ITHACA, N. Y., March 4.—F. G. Wilson, of 56 E. State st., has executed a general assignment to J. H. Jennings, for the benefit of their creditors. The schedule filed prefers certain indebtedness to parents of the assignor. Col. Uri Clark's claim of some \$4,000 appears in the list of common creditors. Mr. Wilson is held in high esteem, and it is hoped and believed that he will speedily adjust his business complications.

The Changed Design Causes Excitement.

CHEYENNE, Wyo., March 5.—A startling legislative transaction was revealed last evening. The Assembly completed its labors fifty days ago and, it was supposed, all misdeeds had been ventilated. During the session it was discovered that the State was without a seal. Designs were solicited and a dozen sketches were sent to the committee, the pattern by Hugo Buechner, a member of the House and a jeweler of this city, being adopted.

It now develops that the design attached to the enrolled bill, as approved by the executive, was altered with a free hand after its acceptance by the joint committee. The gowned figure of a woman, with uplifted arm

and one hand on a shield typifying the freedom of the sex in Wyoming has given place to a modified Greek slave of absolute lewdness. There is deep indignation and a full inquiry will be made.

Sold Gems for Less than Their Value.

BOSTON, Mass., March 7.—The suit of L. Tannenbaum & Co., New York, against W. J. Knowlton, 168 Tremont St., this city, a prominent dealer in precious stones, came up in the Superior Court here last Tuesday. The action was brought to recover \$725 for nine emeralds, the plaintiff contending that his salesman left the emeralds with the defendant in June, 1889, at the same time saying he would ascertain their selling price and inform the defendant thereof; that when he went again to Mr. Knowlton he found that the stones had been sold for \$400, although worth much more.

Testimony was also taken in which it appeared that the defendant claimed to have been told he could have them for \$300, and that he sold them with that understanding. No decision was rendered, but the parties interested compromised the matter later in the week, it is understood, to their mutual satisfaction.

BIRTHDAY RINGS,

In Handsome Novel Window Tray,

(Patented.)

M. B. BRYANT & CO.,

10 Maiden Lane, New York.

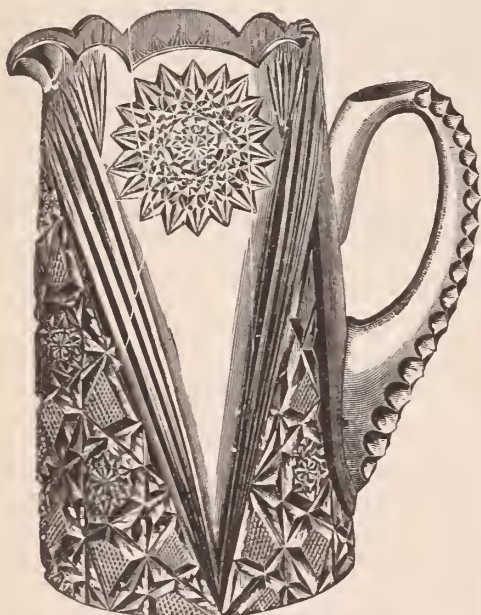

The Latest "PURITAN" Design.

RICH CUT GLASSWARE.

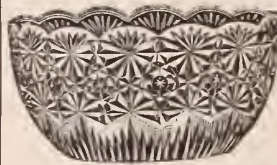

Headquarters in America for
ART GLASSWARES,
RICH CUT AND DECORATED.
Lamps, Vases and complete lines of everything for
table use or household decoration.

MT. WASHINGTON GLASS CO.

NEW BEDFORD, MASS.

NEW YORK OFFICE, 46 MURRAY STREET. ♦ ♦ ♦ ♦ ♦ INTENDING PURCHASERS.

A. J. GROENMAN & CO., DIAMOND CUTTERS,

80 NASSAU ST., N. Y.

**WE MAKE A SPECIALTY OF SEL-
LING FINE, SMALL MELEES.**

GENTLEMEN:—I think the trade this Spring will be better than last, and, although I can turn out double the work I did then, you had better be on hand with your orders, for I expect that my sales will be very large—equal to last Fall, if not double. You see the field is constantly widening and the demand is increasing, and why? Did you ever stop to think that there are 65,000,000 people in the United States, and the per cent. of this number that use glasses is one-fifth, or 20%, making 13,000,000 people wearing eye-glasses, and if you count the myriads in Europe and South America, why it is simply immense, and it needs cultivation. Why! Gentlemen, we ought to be able to double our business every year for the next ten years.

Yours respectfully,

Springfield, Mass.

S. F. MERRITT.

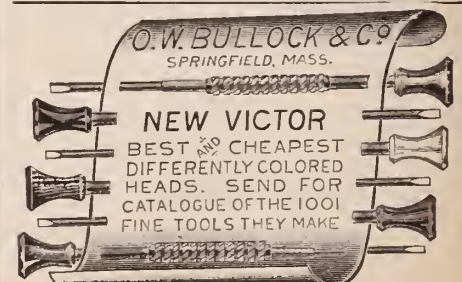

THE
PAIRPOINT MFG. CO.,
 New Bedford, Mass.

FINE
GOLD AND SILVER PLATED WARE.

OUR LARGE LINE
 OF
STAPLES
 AND
NOVELTIES

WILL BEAR INSPECTION.



No. 1250. CAKE BASKET.

Quality
 Guaranteed.

NEW YORK.

CHICAGO.

SAN FRANCISCO.

FOR CLEANING AND POLISHING.

THE LATEST AND THE BEST
POLISH
 FOR
 SILVER, GOLD, NICKEL
 AND GLASS.



WILL NOT SCRATCH
 THE
 FINEST SURFACE.

EVERY RETAILER OUGHT TO HAVE IT IN STOCK.

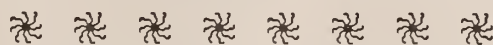

DAVID F. CONOVER & CO.

PHILADELPHIA,

PENN.

C. R. Hollis' Mortgages Set Aside.

LAGRANGE, Ind., March 5.—The opinion, special finding of facts, and conclusions of law of Judge J. M. Van Fleet, in the suits of Louis Gutman, Cincinnati, O., Rogers & Brother, New York, James W. Tufts, Boston, Mass., and other creditors against C. R. Hollis, of this city, have just been published. From the special findings the following conclusions of law have been drawn by the court.

First, that the plaintiffs are each entitled to personal judgments for the amounts of their claims, both due and not due against the defendant. Second, that the plaintiffs are entitled to have a judgment rendered, cancelling and annulling the chattel mortgage of David A. Porterfield (specified in the last issue of THE CIRCULAR) and an order for the sale of the interest of defendant in the goods attached free and clear of the mortgage, but subject to said chattel mortgage of C. R. Hollis, and they are not entitled to sell the real estate seized on the writ of attachment. Third, that none of the plaintiffs are entitled to any relief against the defendants, Cynthia Hollis and C. R. Hollis, or either of them, and that they ought to recover their costs from the plaintiffs.

The decision in the case leaves on the stock a mortgage of \$700 to Jacob Brown, a mortgage of C. R. Hollis of \$6,132 on his stock, and accrued costs estimated to be \$275, making practically \$7,000 on stock to be paid on sale before attaching creditors can obtain

payment of any part. The stock consists of two parts, jewelry \$3,000, and boots and shoes, \$7,675.

From 7,500 Miles Away.

We have before us a copy of the December number of the New York JEWELERS' CIRCULAR, a monthly journal specially devoted to the interests of jewelers, silversmiths, and cognate branches of art industry. As a trade journal it is the best we have ever seen, and the foremost of its kind published in any part of the world. The letter-press is unexceptionable, the illustrations and embellishments superb, and the general arrangement most creditable. The contents of the issue to hand include a large number of well-written articles of special importance to the industry, and of considerable interest to the general public. A contribution from the South African representative of the organ (Mr. Walter Bruce, Pretoria) furnishes its readers with very necessary information regarding the diamond and gold industries, and is not the least valuable feature of the journal.—*Pretoria (South African Republic) Press.*

The Adventures of a Stolen Jewel.

DAVENPORT, Ia., March 6.—J. C. Tilton has just recovered a diamond worth about \$100 that was stolen from him four years ago. One evening in December, 1886, as Mr. Tilton was placing his jewels in the safe preparatory to closing, when a stranger entered his store, asked to see some diamonds

and engaged in conversation. Suddenly he cast a handful of pepper into Mr. Tilton's eyes, grabbed two of the gems and fled. Nothing was ever heard of the thief or the jewels until a few days ago, when Mrs. J. LeClaire wife of a Mississippi River pilot living here, entered Mr. Tilton's store to have a diamond ring repaired. In the diamond in the ring the jeweler recognized, or believed he recognized, one of the long-lost gems.

He brought suit to recover the diamond and the case came off before Justice Peters. Tracing back the history of the stone it was learned that Mr. LeClaire had bought it from a pawnbroker, who in turn had obtained it from a young man named Frank Pepper. The jewel was sold to Pepper by a Mrs. Paul, whose little daughter had found it in an alley a few days after the robbery in 1886. Mr. Tilton identified the diamond by its peculiar "cushion" shape and by a certain flaw or "shiver." The defense of the counsel for the LeClaires was that the identification was incomplete, but the justice decided for Mr. Tilton.

Des Moines Jewelers Burnt Out.

DES MOINES, Ia., March 4.—Fire at midnight, Monday night, destroyed part of the new Marquard Bank block. Hellier & Martin lost their stock of jewelry and sewing machines, which is largely covered by insurance. The loss to the Marquard block by fire and water amounts to \$10,000.

The R. Wallace & Sons Mfg. Co.,



No. 230 CUP. IN STERLING SILVER, TWO-THIRDS SIZE.

MANUFACTURERS OF

Sterling Silver, Plated Ware & Fine Cutlery

FACTORIES, WALLINGFORD, CONN.

{ New York Store: 3 Park Place.
{ Chicago Store: 104 State Street.

Davenport, Ia.

C. S. Durfee & Co. are introducing the fancy lorgnette handle in this city, and it is becoming the fashion among theatre-goers. Prior to this season it has been as good as unknown here.

The Forester Gun club trophy to be contested for during the year 1891, has been received and is on exhibition in the window of Mrs. T. Kircher. It is the work of Rogers, Smith & Co., Meriden, Conn., and is of heavy silver plate, gold-lined, 21 inches high. The design is very handsome. From the base rise four hammerless guns, crossed and bearing a cup, the outside of which is hand-engraved and depicts a live-bird match. Over the guns is thrown a laurel wreath, and a hunting bag depends from its strap.

Jewelry travelers visiting the city houses during the past week were: J. Mayer, of Falkenau, Oppenheimer & Co., R. W. Simpson, of Wm. Riker, F. H. England, of H. Z. & H. Oppenheimer; S. W. Abbey, of E. Ira Richards & Co., and G. Southwick, of A. Alling Reeves, New York; J. P. Osthoff, of Jos. Noterman & Co., Cincinnati, O.; C. T. Whittlesey, of the Julius King Optical Co., Cleveland, O.; J. F. Coan, of the Rockford Silver Plate Co., of Rockford, Ill.; and C. Jeannerat, of Juergens & Andersen, Chicago.

Lancaster, Pa.

F. L. Hostetter and W. H. Denney, clerks in the employ of the Lancaster Watch Co., have been engaged the past week in preparing a catalogue of the property and material of the company. The catalogue will probably be ready in ten days.

At the sale of the assets of the defunct American Life Insurance Company, of Philadelphia, Pa., on Wednesday, 2,000 shares of the stock of the Lancaster Watch Co. were sold for \$75 for the lot, which comprised two-fifths of the capital stock of the company.

There was an unusually large number of traveling men in the city during the past week. Among them were M. Ehlers, of Ehlers & Weber; W. S. Campbell, of Day & Clark; J. McPhail, of Ed. Todd & Co.; Mr. Brenman, of J. J. Cohn; H. C. Schwartz, of Kremenz & Co.; M. Franklin, of E. Ira Richards & Co., and L. D. Frank, of Kahn & Levy, New York, and G. H. Sylvia, of the Mt. Washington Glass Co., New Bedford, Mass.

Norfolk, Va.

I. Frankfurt will leave shortly for New York.

S. R. Smith is displaying on elegant assortment of the "Sumatra Gem."

A. C. Freeman, his auction sale being ended, will reopen in a few days at his old stand, 138 Main st.

Mr. Jakeman, of Chapman & Jakeman, has returned from an extended Southern tour in the interest of his firm.

E. L. Gibson, of Mabie, Todd & Bard, H.

USE THE  **AMERICAN MAINSPRINGS**
FOR ALL KINDS OF AMERICAN WATCHES.
[FACSIMILE OF WRAPPER.]

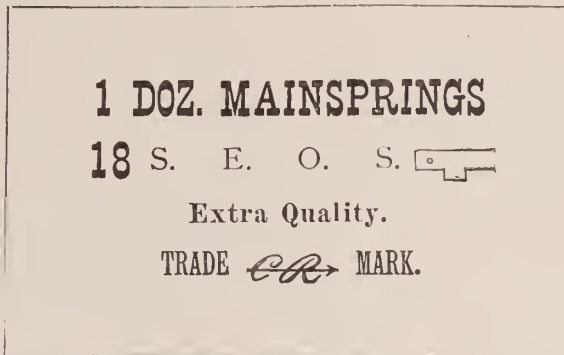

THE BEST IN THE MARKET.

L. H. KELLER & CO.,

Dealers in Fine Watch Materials and Tools.

AGENTS FOR THE PATEK, PHILIPPE & CO. WATCHES.

64 NASSAU STREET, NEW YORK.

LEWIS BROTHERS,
Easter Novelties in Silver,
41 Maiden Lane, N. Y.

ESTABLISHED 1837.
GEO. O. STREET & SONS,
MAKERS OF
Fine Rings, Lockets, Seals, Sleeve
Buttons and Links,
15 John Street, - NEW YORK.

EZRA KELLEY'S
Famous Watch, Clock and Chronometer Oils,

RECEIVED AT THE
EXHIBITION UNIVERSELLE, PARIS, 1889,

The only Award of Merit given to Manufacturers of American Oils

It is to the interest of every Watchmaker to use in his work the **Best Oil** obtainable, regardless of cost. Mr. Kelley's claim to be the foremost manufacturer of Oils, giving the best results, is not based upon his own assertion, but is founded upon the fact that wherever his Oils have been exhibited in competition with other makes, subject to an examination of experts, they have received the highest **Award of Merit**.
For sale by all the Leading Jobbing Houses.

HENRY GINNEL & CO.,

GRIMSHAW & BAXTER, EUROPEAN AGENTS.
35 GOSWELL ROAD, LONDON, ENGLAND.

GENERAL AGENTS,
31 Maiden Lane, NEW YORK

BEST and CHEAPEST DEVICE FOR MAILING

All Mailable Matter at Cheap Postage.

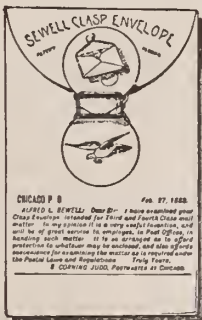

For mailing Trade Catalogues, Samples, Parcels of DRY GOODS, WOOL, YARN, COTTON, SEEDS, GROCERIES, PHOTOGRAPHS, DRUGS, WHEAT, FLOUR, GLOVES, LACES, RIBBONS, CALENDARS, SAMPLE CARDS, and all other 3rd and 4th class mail matter, is

SEWELL'S PATENT ENVELOPE CLASP
(Patented in America and Europe.)

WHICH FITS ON **ANY** ENVELOPE IN THE MARKET.

In a moment it turns *any envelope* into a CLASP ENVELOPE. It is made of tough sheet brass. Anybody can put it on, as it is most convenient, and adjusts itself to a package of any size or thickness. It is endorsed by Postmasters. We also make Envelopes, all sizes and kinds. **SAVE MONEY, and GET THE BEST,** by writing for samples and prices to the

CHICAGO ENVELOPE CLASP CO.,
210 South Water St., CHICAGO, ILL., U. S. A.

ENVELOPES

FOR JEWELERS' AND OTHER TRADE CATALOGUES.

Hymson, of Koch & Dreyfus, W. H. Thornton, of Krementz & Co., L. C. Moas, of R. & L. Friedlander, J. E. Tully, of J. E. Tully & Co., W. A. Weichman, of Wood & Hughes, G. Hoffman, of the Ansonia Clock Co., J. McPhail, of Ed. Todd & Co., New York. J. Engel, of M. Daniel, and J. E. Valk, of Hennegen, Bates & Co., Baltimore, Md., J. H. Thompson, of Bioren Bros., Newark, N. J., N. S. Valk, of the Meriden Britannia Co., Meriden, Conn., A. R. Weisz of the Illinois Watch Co., Springfield, Ill., and W. H. Bradley of M. Zineman & Bro., Philadelphia, Pa., were in the city last week.

Connecticut.

F. Heitch has opened a new jewelry store on the upper part of Grand ave., New Haven. Watch and clock repairing is a feature of his business.

S. Choroginsky, since removing his jewelry business to Congress ave., New Haven, has prospered. His is the only store of the kind on that busy and populous thoroughfare.

R. N. Johnquest & Co., Ansonia, receive many compliments upon the handsome appearance of their fine new store, opened a few weeks ago, and in which they are more conveniently settled. It is acknowledged to be one of the finest stores in the Naugatuck.

C. G. Earle, New Haven, is closing his business preparatory to removing to another city. He contemplates opening a jewelry store on either Eighth ave., New York City,

or in Brooklyn, N. Y. He is holding auction sales at his store nightly. N. H. McFarland, of New York, is conducting the sales.

Gen. Geo. R. Ford, New Haven, is making a valuable collection of works relating to the history of New Haven, and of the New Haven and Massachusetts colonies, some of which are of costly character. His most recent addition is a set of volumes originally expensive but now far more so, as the edition is exhausted and out of print. It is a complete set of the "Records of Massachusetts' Colony, six volumes, 1628 to 1700." They are large volumes, and very complete and authoritative historical records.

Terryville has a historic clock which just now is awakening historic interest in this State, and recalls to mind to many persons the valuable historic articles on clock making in America which are running in THE CIRCULAR. The senior Eli Terry, the pioneer clock-maker after whom Terryville was named, made a large tower clock, which, when completed, was considered to be a marvel of ingenuity and fine workmanship. In 1840 it was presented to the Congregational Church in Terryville, and placed in position on the church tower. There in its lofty position it has unfalteringly and indomitably told the people of all that section the correct time without cessation or interruption for over half a century. For the first time in its history it last week showed signs of irregularity of behavior. Last Monday Col. Hayden, of the Seth Thomas

Clock Co., carefully examined the old tower piece and reported it to be but little worn and that with the thorough cleaning which it now will receive, it is good for faithful and correct service for another half a century.

Indianapolis.

The report that Horace Comstock was contemplating closing out his business on East Washington st. is untrue. He says he has no intention of doing so.

The Louis Bergheim Co., of this city, have concluded to open a branch store in Elwood, the prosperous little natural gas town in the eastern part of the State. A handsome corner room in a new block has been rented for the store.

A sentiment is growing in the city in favor of a combination of the jewelry dealers against the indiscriminate sellers of cheap articles of jewelry in connection with some other business. The two leading dry goods establishments have been filled up with a stock in an effort to cover the entire mercantile field.

Baldwin, Miller & Co. have noted the fact to your correspondent that while February and March are the months when Christmas bills become due, there has not as yet been a single failure in the State. This is taken as evidence that the retail jeweler reaped a goodly profit on his holiday sales. But all are just now grumbling a little at the dull times they are experiencing.

ESTABLISHED 1841.

CARTER, SLOAN & CO.

MANUFACTURERS OF

FINE JEWELRY,

15 MAIDEN LANE, NEW YORK

A. CARTER, JR.
A. K. SLOAN.
C. E. HASTINGS.
GEO. R. HOWE,
WM. T. CARTER.



Factory, NEWARK, N. J.

M. S. Smith Undergoes a Painful Operation.

M. S. Smith, founder of M. S. Smith & Co., now F. G. Smith, Sons & Co., Detroit, Mich., who has been stopping at the Fifth Avenue Hotel, New York, for several weeks, and has just undergone a most painful and remarkable surgical operation, is convalescing rapidly. To a CIRCULAR reporter who called at the hotel last Thursday, it was stated that he was unable to see visitors, but that he was past all danger of a relapse.

About a year ago Mr. Smith was suddenly taken ill at Birmingham, Eng., and his family were telegraphed for, to be present at what was supposed to be his death-bed. Mr. Smith's disease was in the kidneys. A pus sack had formed on one of them, which became very badly affected. Dr. Helmuth, of New York, performed an operation on Mr. Smith, which to the unprofessional mind, almost seems incredible. He cut through into Mr. Smith's stomach, removed the pus sack containing more than a quart of matter, took out one of the kidneys, and removed the diseased parts; he then returned the kidney to its place, and sewed it to the walls of his stomach.

The Manhattan Silver Plate Company May Move.

LYONS, N. Y., March 6.—The question of retaining the works of the Manhattan Silver Plate Co. at this place, is being actively discussed. The question must be early decided, as the company have been offered \$25,000 by citizens of Babylon, L. I., who are desirous of having the factory located there, and the New York stockholders, who hold the control, are in favor of accepting the offer. This is the silver plate company that THE CIRCULAR, in its last issue, spoke of as likely to locate at Babylon.

According to the provisions of the company's charter, a vote of two-thirds of the stock is necessary to change the location of the factory, or to increase the capital stock. The stock at present is \$75,000, so that if \$25,000 of it is held in this city by parties who are desirous of retaining the company here, it must stay. At present by far the greater portion of the stock is held by New York parties. Thirteen thousand dollars of additional stock is necessary to keep the works here.

A petition is being circulated among the citizens; about \$7,000 of stock have been so far subscribed for.

A Conscience-Stricken Thief.

REGINA, Man., March 6.—J. Daykin's jewelry at this place was broken into a few nights ago by a burglar. Mr. Daykin being awakened by the breaking of a large pane of glass, seized his revolver and went in search of the thief.

On seeing the man he fired, but the ball flew wide of the mark. The robber escaped with about \$50 worth of jewelry, but it is evident that he was overcome by a feeling of repentance soon afterwards, for the whole of his plunder was brought back next morning and laid on the window sill.

ESTABLISHED 50 YEARS.

RANDEL, BAREMORE & BILLINGS,

IMPORTERS OF

DIAMONDS,

AND OTHER PRECIOUS STONES.

FINE PEARLS A SPECIALTY.

MANUFACTURERS OF

DIAMOND JEWELRY,

IN THE LATEST DESIGNS.

Diamonds Recut in Modern Styles or Repaired on Premises.

58 Nassau Street,
29 Maiden Lane,
NEW YORK.

1 Tulp Straat,
AMSTERDAM.

1 St. Andrews St.,
Holborn Circus.
LONDON, E. C.

LARTER, ELCOX & CO.

MANUFACTURERS OF

THE SPRING BACK STUD.

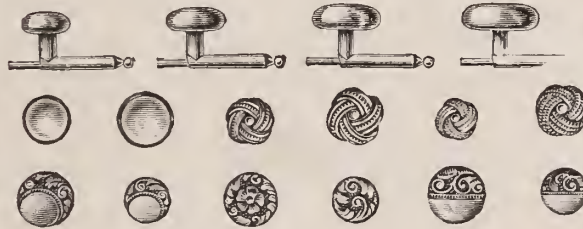

—
SNAKE RINGS.

GENTLEMEN'S

—
WHITE · ONYX · JEWELRY.

—
LADIES' RINGS.

—
Gentlemen's Rings.

Send for Selection Package of Studs.

FACTORY, NEWARK, N. J. + + OFFICE, 41 & 43 MAIDEN LANE, N. Y.

ORIGINAL

GOOD FRIDAY NOVELTIES,

—
IN
STERLING SILVER.

FRANK H. LA PIERRE,

No. 18 EAST 14th STREET,

NEW YORK.

Ludwig Nason
Moore & Horton
18 JOHN ST. NEW YORK

MOORE & HORTON,
MANUFACTURERS OF
SOLID GOLD JEWELRY,
No. 11 Maiden Lane, New York.
Fine Imitation Diamond Goods a Specialty.
Selection Packages sent on Application.

ALVIN MFG. CO.,
Silversmiths,
860 Broadway, New York,
206 Kearney St., San Francisco,



DESIGN—OYSTER SHELL—SALT.

MADE IN LARGER SIZES FOR ASH
TRAYS, &c.

Design Patented.

ALEX. WIEDERHOLD,
20 MAIDEN LANE, N. Y.,
REPAIRING JEWELER.

Jobbing sent to me by mail or express will be repaired and returned promptly. Prices Moderate and First-class Workmanship Guaranteed.

"THIS RING, WHOSE HIGH RESPECT AND RICH VALIDITY
DID LACK A PARALLEL."—SHAKESPEARE.

HILDRETH MANUFACTURING COMPANY,

53 MAIDEN LANE, NEW YORK.

PLAIN SOLID GOLD RINGS AT LOWER PRICES THAN YOU
ARE PAYING. SEND FOR SAMPLES. QUALITY GUARANTEED.

KENDRICK & DAVIS,
LEBANON, N. H.

MANUFACTURERS OF THE



Standard Dust Proof Watch Key.

After this date all Keys of this Style will have number
stamped on each Key.

FOR SALE BY THE TRADE.

Climbed through the Transom.

AMSTERDAM, N. Y., March 4.—A very daring and clever robbery was committed in this city between six and seven o'clock last evening, by which W. E. Cross lost nearly \$1,000 worth of goods.

While he was at tea and while an electric lamp was burning in the store window, a thief climbed through the transom over the rear door of the establishment, and passing through the store went to the show window and robbed it of twelve gold watches, a tray of rings and a diamond bracelet. He did this while hundreds of people were passing the store.

It is customary for the jewelers of this city to close their stores at six o'clock, as was done by Mr. Cross this evening. When he returned at seven o'clock to replace his most valuable goods in the safe, he discovered the robbery. There is no clue to the thief. The rear door of the store was found open.

Canada Not Barren of Gems.

OTTAWA, Ont., March 6.—Only a few years ago it was thought that Canada was almost entirely barren of gems and precious stones, and no doubt it will surprise some to hear that, within the last three or four years, quite a business has been developed in those articles. Prof. Willmot lectured on the subject last week at the Normal School in this city, and exhibited a large and interesting collection of specimens, cut and polished, and uncut. He stated it was remarkable how many stones were found in Canada, which were available for gems, and which rivalled in brilliancy and beauty many of the Oriental and so-called rare gems. The Laurentian rock of Canada contained a large variety of minerals suitable for gems, but nowhere in large quantity.

Specimens of quartzasteria, labradorite, agates, emeralds, sapphire, chalcedony, jasper, amethyst, etc., and a long list of over one hundred minor varieties were discussed.

Two Robbed While Another Talked.

CHICAGO, Ill., March 4.—Three men robbed the store of Nathan Bloch, 48 Wells st., about 8 o'clock on Saturday night. A man walked into the store and, after looking at some gold studs, began to examine some gold watches at the back part of the store. While the jeweler was showing his goods, two men outside were cutting a big hole in the plate-glass window. Mr. Bloch heard the noise and started for the door, but his customer grabbed him and threatened to shoot him if he made any outcry.

When the men outside had all the goods that they could carry, the confederate inside rushed to the door and escaped. They carried off eight gold watches, several clocks, four revolvers, a dozen gold chains, and several pairs of cuff buttons. Two hours later, Officers Bell and Hyde arrested Peter Arado, George Pekin and Julius Hening for the robbery. They were identified, and the stolen goods were found upon them. Pekin has served a term at Joliet, and the others are well-known to the police.

★ ROGERS & BRO. A-1.

OLDEST BRAND MADE.



AFTER DINNER Coffee Spoons

We invite attention to the designs illustrated above, which are now having a large sale.

ROGERS & BROTHER,

WATERBURY, CONN.

MANUFACTURERS OF THE CELEBRATED

STAR BRAND

GENUINE ROGERS' GOODS,

SHOW ROOMS, No. 16 CORTLANDT STREET, N. Y.

Photograph Albums and Price Lists furnished to the trade only, on application, accompanied by business card.

CROSS & BEGUELIN

21 Maiden Lane, N. Y.

IMPORTERS OF

SWISS WATCHES,

ALL GRADES,

From the lowest to the highest priced.

DIAMONDS,

Watch Material, Opera Glasses.

JOBBER'S OF ALL GRADES OF

AMERICAN ♦ WATCHES,

Gold and Rolled Plate Jewelry.

We carry a large stock and can supply you with any goods a Watch Dealer needs. Next time you want anything in our line, give us a trial. Orders filled same day as received.

SELECTION PACKAGE SENT ON SATISFACTORY REFERENCE.

SEND FOR PRICE LIST.

NOTICE.

The undersigned having purchased the interest of Mr. GEORGE OWEN in the firm of G. & S. OWEN & Co., have this day formed a new co-partnership under the firm name of SNOW & WESTCOTT, for the purpose of continuing the business heretofore carried on by the late firm of G. & S. OWEN & Co.

JAMES P. SNOW,
CHARLES E. WESTCOTT.

March 2, 1891.



ENAMEL AND NET WORK JEWELRY FASHIONABLE
—SILVER-PLATED LAMPS ON THE MARKET—
PHOTO-ENGRAVING TO JEWELRY.

PARIS, France, Feb. 27.—Enamel work is taking more and more importance in jewelry. Bracelets formed of a succession of square, oval, or circular plates, exhibiting intricate ornaments and rosacae in enameled gold are very fashionable. They are made in various colors, with a ruby, a sapphire, or an emerald circled with brilliants, in the centre. I have seen also studs, earrings, hair-pin heads, rings, buckles and garter clasps decorated in the same style. There is a delicate, fragile look about it like a jeweled ceramic.

Net work jewelry made of gold or platina, is still fashionable. It answers better than any to reproduce fine lace and butterflies' wings. In that pretty line, some jewelers add brilliancy to lightness in placing a tiny diamond in every one of the intersecting points.

Beautiful specimens of small artistic work in chased gold are on view in all our aristocratic shops. The scenes, flowers and portraits executed with attenuated reliefs by our best chasers on brooches, bracelets, comb-heads, fan stalks, umbrella handles, cane tops, etc., are extremely pretty. The delineating line, I mean that where the raised work starts from the background is very faintly indicated, although the metal is evidently glypted out, rather looks as though, being handled in a soft state, it had been like clay, fashioned with a wooden tool. The mark of a steel *ciselet* is nowhere visible. There is, besides, a fine, almost tender appearance about those dainty works of goldsmith's art that can only be obtained with a thin deposit of pure gold over the piece once finished.

In the electro-plated line, lamps of varied shapes and styles are coming out; ovoidal, spherical, square, triangular, conical, etc., with stamped or repoussé ornaments and chased appendages. The most striking among them exhibit, on the body, renaissance scenes, nymphs and satyrs romping, allegorical groups, etc.; the stands generally consist of dolphins or tritons, and chimeras form the handles. Some lamps, decorated in a pseudo-Japanese fashion, are held in the uplifted beak of a heron or a stork.

Photo-engraving is applied on a large scale to silver jewelry, and also to hollow wares. A very original bracelet, adorned in that process, represents a party of gypsies inspired by Callot's series. The figures are shadowed out on a foggy background. It gives a weird effect seldom seen on bracelets. Photo-engraving, as applied to the decoration of tea-pots, coffee-pots and trays, does not always give the best results. The lively scenes often represented in that line, are

sometimes like mere sketches, faintly shaded through being oxidized.

A *rapport* on ancient and modern jewelry, with a view to examine how far *joailliers* of the present day are superior to their ancestors, has been read at the *Chambre Syndicale des Bijoutiers*, by Mr. O. Massin, the eminent artist jeweler, and a copy of that interesting essay has been offered to every one of the members. I very much regret that the author should have been so reticent about modern processes and practical means of obtaining the greatest variety of effect possible in arranging precious stones with almost invisible mountings. Evidently Mr. Massin did not choose to become our teacher. I am sorry, also, to see that his short work contains no illustration. I shall give you in my next gossip the most striking passages of his *rapport*.

Short handled eye-glasses, prettily decorated, are selling well just now. Most of the handles are of the so-called violin shape, like an elongated 8, in pierced silver with jewelled ornaments. A few in dark tortoise shell, are covered with light floral *motifs* in applied chased gold.

A great variety of original candlesticks and candelabra in massive silver are coming out. The prettiest are rather short with a wide base. Some, with two branches gracefully curled, exhibit on the tray a fawn and a nymph in dancing attitude, with their backs turned to the column, which forms the body of the piece. One has the shape of a tree with roots curiously twisted, stretching around the base that forms a ground. Some infants play at the foot of the tree, and two are in the act of climbing it, eagerly eyeing a nest placed on the top, on which a bird stands. The six branches that shoot about are well calculated to complete the effect, and to preserve, the true character of a candelabrum. Many small candlesticks are decorated with cloisonné enamel, showing pretty gold arabesques which run through a vari-colored ground. A few, of a light and elegant shape consisting of curved out lines, are encrusted with rubies, emeralds and sapphires, arranged so as to form floral ornaments and finished off with snowy white silver and polished yellow-gold tastefully opposed.

Starting from the fact that several gold nuggets have been found in the southern center of France within the last sixty years, a prominent contributor to an evening paper is strongly advising people who have ready money at their command, to undertake well-conducted diggings in two of our departments, viz.: The Puy-de-Dôme and the Ardèche. He feels confident that they are certain to find it worth the trouble. I am afraid his advice will not be acted upon. Yet, besides the nuggets above mentioned, it appears that many fragments of gold quartz have been found in various parts of France. Who will take upon himself to ascertain whether this country is still worthy of the name of *Gallia aurifera*, which Cæsar would not have bestowed upon it without reason?

H. Brick is about to open a fine stock of jewelry at Garretson, S. D.

FASHIONS in JEWELRY

A Lady's Ramble Among the Jewelers.

Jet girdles have come into being.
 Orchids are now produced in porcelain
 Silver and gilt spoons have shallow bowls.
 Purses of gilt net have the monogram on the side.
 Silver cover holders have bands of repoussé work as handles.
 Antique gold embroidery is imitated in silver on portfolio covers.
 Brooch-like chatelaines of knotted gold wire are used as watches.
 Spinning-wheels in porcelain have been brought out as mantel ornaments.
 Japanese crepe, instead of satin, is used as lining for cases for silver and jewelry.
 Hour glasses are ornamented with bevels, cut so as to show the clear glass beneath.
 Oblong silver trays with repoussé edges are filled with long bars of colored sealing wax.
 Coral and pearls in horseshoes, bars, love-

knots and hearts are among the pretty pins.

Lizard skin is so delicate in its marking and tints that it looks like white lace on a black ground.

Bag clasps in Russian silver are used on velvet bags of the tint that prevails in the ornamentation.

Spoons of Italian workmanship have their stems surmounted by delicate spire and lantern like forms.

French stick pins are jet-black in such designs as cats, dogs, rabbits and jockeys on horses. They are chic.

Low single candlesticks are of Russian silver and French gilt, with porcelain medallions ornamented with flowers.

Queen chains have twisted knots at the end, and these are enameled in solid colors such as dark blue and dark red.

Intaglios are in favor. Sleeve buttons of semi-precious stones are ornamented with intaglios, cut on convex surfaces.

An oblong bar of aquamarine has a mythological subject cut in intaglio, and is bordered in a row of closely-set diamonds.

A band of gold lace for the neck has a design worked out in pearls and diamonds, and is edged with closely-set rows of small diamonds.

Bonbon spoons keep their place among the novelties. A handle of palm leaves in partial gilt with stalks of full gilt, is a new

design. The greenish tinge of the leaves is in pretty contrast to the dead gold.

Cigar and cigarette boxes of metal made to resemble a modern box with plainly bound edges in dull silver are unique and significant.

Why should asparagus tongs have their handles ornamented with vines and grapes? The asparagus stalk might be valuable in decorative design.

The chrysolite has become valuable in jewelry by reason of its attractive effects under light. A watch of this stone is set with clover leaves in diamonds.

Horseshoes, double and triple, of coral, turquoise, and pearls strung on wishbones, clover leaves, and other forms indicating good fortune, are in high favor.

Bracelets of twisted gold, knife edges, flat braids of open work and gold tapes, are in better form than the clasped bracelets, with imitation insects and flowers. Beaten work in segments, powdered with diamonds and colored stones, retain their place.

Hairpins are bewildering in variety. A bumble-bee of silver wire encrusted with diamonds, and having a large diamond for the upper part of the body, is a work of art. Such ornaments are set so delicately on twisted pins that they are constantly in motion.

ELSIE BEE.

IMPORTANT NOTICE.

The New Trenton Movement.

H.T.G. and O. F. S. W.



(OPEN PLATE.)



(CLOSED PLATE.)

We beg to notify the trade that we have placed on the market a NEW MODEL

18-Size, Seven Jeweled, S. W. Nickel Movement,

SURPASSING ANYTHING YET MADE FOR THE PRICE, and to which we invite your attention. These movements possess several new features which offer special advantages to watchmakers. They are Quick Train, Straight Line Lever Escapement, and have Safety Centre Pinions and hard enamel Dials. The barrel can be removed without disturbing the train or stem-winding parts. They are beautifully damaskeened, well finished and attractive in appearance and are EXCELLENT TIMEKEEPERS. EVERY MOVEMENT FULLY WARRANTED.

The Best Low Priced Movement in the Market.

FOR SALE BY THE JOBBING TRADE.

Send to your jobber for a sample movement. If he does not keep them, write us and we will furnish you the names of jobbers who do.

TRENTON WATCH CO., Trenton, N. J.

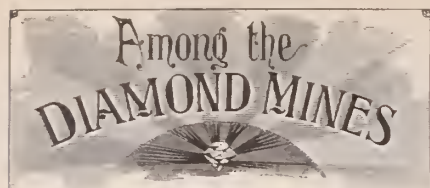

PROGRESS OF THE DEBRIS WASHING INDUSTRY
—DIAMOND TRADE FIRM—MANUFACTURING
GOLD QUARTZ AND ITS CONSEQUENCES—I. D.
B. STILL FLOURISHING.

PRETORIA, South Africa, Jan. 25.—The importance of the debris-washing industry at Kimberley continues to increase. I had proof of this during a recent visit to that centre. At the office of M. H. Theeman there was a glittering array of diamonds amounting to 30,000 karats valued at—well, that is a secret of the trade. This may be said, however; the splendid parcel, or rather series of parcels, has been purchased by the firm during the past few weeks and represents in the aggregate, steady work of many persons, who, but for the debris-washing industry would scarcely have known where to turn to earn a shilling to provide their families with a living meal. Those debris diamonds do not represent one or two transactions effected with lordly claimholders or autocratic managing directors, to whom a cheque for a thousand or two is but a trifle. They are tangible results of many sales in which the modest "finer" was a frequent grand total, and in which the value of the purchases seldom got beyond two figures.

This large accumulation of diamonds was very carefully classified, so that the visitor could examine the various parcels, and in fact receive quite an interesting object lesson in the delicate manipulative art of diamond sorting. Here was a brilliant little kopje of pure light represented by some 5,000 karats of melle and "close" goods, many of the stones being four, five and six karats. Here, a darker shade of "common brown"; again, a fine grouping of rose diamonds; in one corner a parcel of pretty round fancies which have a ready sale when they are polished in

Paris; and in the other, an assortment of spotted stones which, when broken, yield fragments of the purest white. The bortz was remarkably small in quantity. The diamonds have since been mailed to Europe.

The diamond trade is decidedly firmer at present and therefore the debris-washers find a ready market for their goods. The De Beers Company can, of course, practically control production, and at any time, if the demand abroad should be extraordinarily brisk, they could considerably control prices. They, nevertheless, promise that the price shall not exceed 30s. per karat here, unless the cost of production unexpectedly increases.

The desire to become rich rapidly is the cause of much crime and evil practice in South Africa, as in other places. One of the latest phases of mine salting is just now engaging considerable public attention. There is under arrest an American named Charles L. Levy, said to be well known in New York, on a charge of fraud in this connection. Accused came to this country with some diamond drills, and took contracts for boring on gold properties. Some twelve months ago, Levy showed a core, which disclosed splendid results, and reported that it had been obtained from a certain property at Johannesburg. Some little sensation was created at the time, and large sums were given for an interest in the property. Shafts were sunk and other developing work conducted, but the property was found to be practically worthless. The allegation is that Levy manufactured the quartz and inserted it in the drill.

Manufacturing gold quartz is, however, developed to a fine art and many mining experts have to acknowledge that they have been caught. Real gold is introduced into ordinary pebbles or other stuff and made to appear as like the natural auriferous formation as one can well imagine. Nevertheless, Nemesis sooner or later appears.

The crime of I. D. B. still flourishes at Kimberley despite the elaborate detective organization and the heavy punishment on conviction. Five, seven and even ten years imprisonment with hard labor is the penalty.

The Latest Paris Novelties.

PARIS, France, Feb. 28.—Cleopatra's asp, reproduced with almost all gems and metals, has been equally welcome on patrician heads and bourgeois' bodices. Joan of Arc's sword, rather freely copied in a dazzling style, has adorned many a corsage more or less worthy of exhibiting that badge of virtue and valor.

Brooches, earrings, bracelets, neck-pieces, pins' heads, and even rings consisting of jeweled enamel are very taking. The bracelet and the necklace are made of a succession of medals in enamelled gold, in low or high relief, representing historical portraits and enriched with diadems and crowns as well as chains of order and breast ornaments realistically brought out with finely chased gold and gems of various colors.

I have seen in some of our best places a great variety of pepper-grinders in silver, some of which exhibit curling ornaments in repoussé or etching and some are decorated in Vernis-Martin or enamel work. Most of them are cylindrical in shape with very slight curves. A few show, on the moving part or handle, figures of monkeys, clowns, firemen, nymphs, etc., in sitting, crouching, pulling and playful attitudes; one figure at each end.

Money-boxes in silver are also worthy of notice. Some of them are massive in appearance, but are rather soberly decorated. All are provided with a tiny padlock so as to make thieves understand, no doubt, that it would be almost easier for them to pocket the pretty little safe than to attempt to open it. One of these boxes exhibits at the top a Cupid bending over to have a peep at the money-hole, while some other daring imps are climbing on the sides, grasping at branches which cover the body of the piece.

Another one, in the shape of a Sedan chair in Vernis-Martin, is carried by two footmen gorgeously attired in vari-colored gold. A third, which is a truncated Corinthian column, exhibits a statuette of Fortune standing on one foot at the top.

R. B. Roddy, has removed to 33 Ohio street, Alleghany, Pa.

THE Courvoisier Wilcox Mfg. Company's

NEW 10-K. GOLD WATCH CASE,

In O and 6 Sizes.

Unsurpassed in beauty; style and finish, costing no more than the better grades of filled cases; will wear for longer than a lifetime, and will always be a *Solid Gold Case*.



BURDON'S · SEAMLESS.

THE · ORIGINAL
And only Genuine



AND
Perfect Seamless Filled Wires
IN THE WORLD.
Sold to all Manufactur-
ers alike.

Burdon Seamless Wire.

TRADE-MARK.

The success of the BURDON SEAMLESS FILLED WIRE, like that of all important inventions, has been followed by deceptive and imperfect imitations. For the protection of

ALL JOBBERS AND RETAILERS,

we authorize manufacturers who so desire, to affix upon the tag, card or label accompanying the articles made from this wire, this registered trade-mark owned by this Company.

The bird-on-wire is a guarantee that the goods are made from the original Burdon Seamless Filled Wire, the reputation of which has been firmly established among the best dealers for more than two years. The perfection and qualities of the Burdon Seamless Wires are always guaranteed. **All Dealers** (jobbers and retailers alike) should, therefore, demand goods made from the original Burdon Wire, and avoid imitations which are offered as "just as good."

BURDON SEAMLESS FILLED WIRE CO.,
109 to 119 and 127 Summer Street,
PROVIDENCE, R. I.

TELL A. BEGUELIN, IMPORTER OF WATCHES,

Watch Materials, Tools and Glasses,
No. 71 NASSAU STREET,
(UP STAIRS.) NEW YORK.

Cor. John Street, NEW YORK.
Sole Importer of Material for the
"Bijou," "Victor," "Boston," "Bristol,"
"Adelphia," "Jockey Club," "Wallingford,"
"Cæsar," "Lady Racine" and "New Haven"
Watches.

AMERICAN WATCHES.
ALSO STEM WIND WHEELS.
IMPORTER OF
Full Line of SWISS WATCHES.
ALSO IMPORTER OF
FRENCH CLOCK GLASSES.

TO THE TRADE.
FINE WATCH REPAIRING
BY
JOHN C. SIMMONDS,
18 JOHN STREET, NEW YORK.

New pieces, such as Chronometer Locking Springs, Balance Staffs, &c., made in the best styles. Watches sprung and adjusted to temperature and positions.

ARTIFICIAL EYES!



STOCK ORDERS of
Selection Packages.

Largest Assortment.

GENEVA OPTICAL CO.,
23 Washington St., Chicago.

R. & L. FRIEDLANDER, Wholesale Jewelers,

—AND—

JOBBERS IN AMERICAN WATCHES,

Tools, Materials and Optical Goods,

65 & 67 NASSAU STREET, N. Y.

Factory, 50 BOND STREET.

Send Business Card and we will mail you our Watch and Jewelry Catalogue, No. 12,
and our Tool, Material and Optical Catalogue, No. 14.

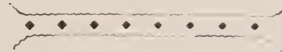

Try our Monarch American Mainsprings, \$12.00 PER GROSS,
\$1.00 PER DOZEN.

POSITIVELY NO GOODS SOLD AT RETAIL.

Established 1872.

PLAINVILLE STOCK CO.



BROOCHES, SCARF PINS, DROPS, SETS.
FACTORY AT PLAINVILLE, MASS. SAMPLES AT 176 BROADWAY, NEW YORK

DIAMOND SETTINGS. GALLERIES. HOLLOW BALLS, ETC.

BLANCARD & CO.,

36 & 38 JOHN STREET,

SEND FOR OUR NEW YORK. CATALOGUE.

Jules Jürgensen

OF COPENHAGEN.

The reputation these watches have maintained for Fifty Years has never been equalled, being made on strictly scientific principles, and no expense spared to give the Best results in mechanism and timekeeping qualities.

SOLE AGENTS,

John G. Hyde's Sons,

No. 22 [Maiden] Lane.

OPPENHEIMER BROS. & VEITH, Diamonds, Watches and Jewelry,

2 Tulp Straat,

AMSTERDAM.

35 Maiden Lane,

NEW YORK.

We beg to inform the trade that we are still in a position to fill orders for

✂ DUEBER HAMPDEN WATCHES ✂

Of all grades, from stock purchased previous to the closing of the factories at Canton.

JOHN A. RILEY & SLOAN CO.,

860 BROADWAY, NEW YORK.

EASTER NOVELTIES,

INCLUDING

ROSARIES AND CRUCIFIXES IN GOLD AND SILVER.

ALSO HAIR PINS, TIARAS AND A GENERAL LINE OF GOODS
FOR LADIES' WEAR.

Send for Catalogue and Price List.

The "BRYANT" Initial Ring.

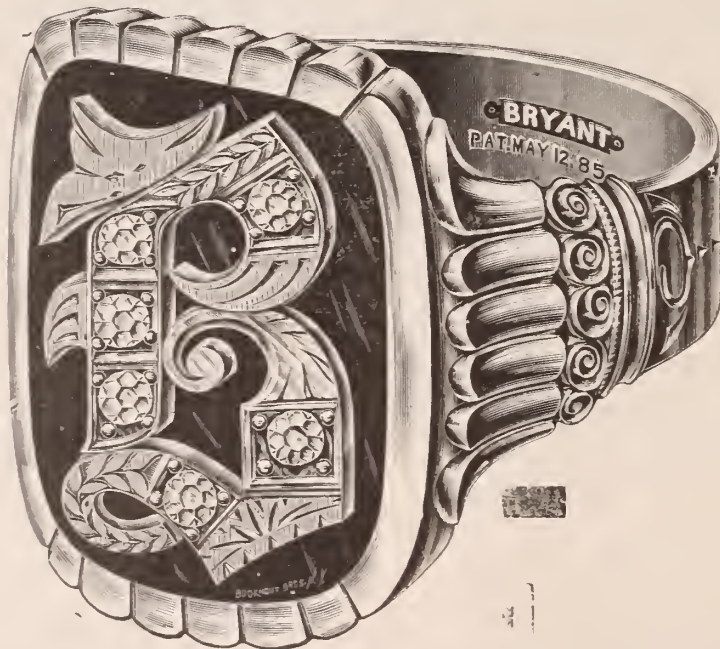

In Various Styles, Most Easily Interchangeable,
Handsomest and Best.

M. B. BRYANT & CO.,

10 MAIDEN LANE, - - - NEW YORK.

News Gleanings.

C. Davis, Honey Brook, Pa., has sold out.
W. R. Call is out of business at Antrim, N. H.

G. D. Rehinberg, St. Augustine, Fla., has sold out.

D. B. Harper, Annville, Pa., is out of business.

J. B. Hess has succeeded Fuller & Clark at DuBois, Pa.

J. O. Adams, Athens, Tex., has sold out to J. J. Powers.

Reton, Bros. & Co. have given up business at Marinette, Wis.

Louis Ries has succeeded McCall, Ries & Klein at Portland, Mo.

V. E. Dake has moved from Cadott, Wis., to Augusta, same State.

J. M. Terry has given up his jewelry business at Brownwood, Tex.

E. Meechler has moved from Barnesville, Minn., to West Bend, Wis.

O. W. Morey, Valentine, Neb., has moved to West Point, same State.

L. C. Campbell, recently at Perry, Mo., is now at Canton, same State.

C. S. Raymond, the well-known Omaha, Neb., dealer is selling out his business at auction.

A. C. Harley has given up his store at Berryville, Ark., and moved to Harrison, same State.

W. C. Allen, Ulysses, Pa., has succeeded C. M. Allen. The latter has moved to Westfield, same State.

T. Rohner, Clarksville, Tenn., has admitted his son into the business, which is continued under the name of Thomas Rohner & Son.

C. F. Osgood has retired from F. H. Shearer & Co., Bay City, Mich., and G. H. Shearer has been admitted. The firm name remains unchanged.

The trade in Kansas is quiet, the boom in many of the towns having passed. Dealers are awaiting the intentions of the Farmers' Alliance. At present the tendency of money is to make its way back to the East.

In Churdan, Ia., there are two N. L. Jennings, one a jeweler, the other a dealer in notions. The report recently published that Jennings & Harrison had succeeded N. L. Jennings, referred to the notion house. N. L. Jennings, jeweler, remains unchanged.

Little Martha Hitze, daughter of E. Hitze, Erie, Pa., is just five years old and has recently developed such extraordinary talent for singing and acting that she has already won quite an enviable reputation as an entertainer, having appeared prominently in numerous entertainments in Erie and Buffalo. Her remarkable beauty, cute, childish manners and sweet voice have won her a host of admirers and warm friends, and have made her the pet of every salesman who visits Erie. In character pieces she acts the parts according to her own conception of them and in

such an original manner as to invariably excite tumultuous applause.

A. C. Abeytia, Las Vegas, N. M., was last week visiting in Santa Fe.

B. T. Ash & Co., at Binghamton, N. Y., have enlarged their store.

W. L. De Graff, Cocoa, Fla., has organized a watch club of twenty members.

J. E. Jarck, Danville, Va., has returned from a three weeks' trip to the North.

H. H. Burnham has removed from Birmingham, Conn., to South Bridgton, Me.

A. H. Potter, Waltham, Mass., is selling out his stock as he must vacate his store on April 1st.

A. Van Dima, Key West, Fla., has just placed an illuminated clock in his show window.

C. J. Seeger, Bartow, Fla., has moved his business to larger quarters in the same village.

E. F. Gilbert, Jacksonville, Fla., has placed in his store a handsome safe weighing 4,500 pounds.

C. H. Bartlett, Trinidad, Col., is moving to his new store a few doors from his old location.

Mrs. E. C. Keil, Rockford, Ill., removed last week from the Seventh st. store to one on East State st.

Samuel Carpenter, Mauch Chunk, Pa., has in his possession a silver penny bearing the year 1796, which he highly prizes.

W. A. Simmons, Frederick, Md., has a valuable old coin known as the Massachusetts Pine Tree shilling, bearing the date of 1652.

Geo. Bicknell, of F. S. Gilbert, Attleboro, Mass., and E. Beckwith, of the Julius King Optical Co., were in Syracuse, N. Y., last week.

J. S. Newing, Binghamton, N. Y., is conducting a special sale of spoons. He visited New York last week to purchase new goods in that line.

In a fire which destroyed a business block in Washington, Ind., the store of H. C. Thomas was burned. The loss on stock was about \$1,000.

C. F. & L. Uhl, Cleveland, O., will remove in a few weeks from No. 1 Euclid avenue into larger quarters at Nos. 141 and 143 Euclid avenue.

G. F. Levy, Seattle, Wash., while laboring under a severe illness, made an attempt at suicide recently. He fired two shots at himself, but both went wide of the mark.

Spott & Spott, Richmond, Va., have removed into their new store, 405 E. Broad st., in which they have placed an entirely new stock of goods in the latest styles.

J. M. Frear, Binghamton, N. Y., has a fine English setter valued at \$100. He calls it Gorham because it was presented to him by the Gorham Manufacturing Co.

Harry U. Rogers has a good stock of jewelry, clocks, watches, etc., that he has just placed in the brick drug store at Luverne, Ia.

E. W. Pollock, a young man who had a jewelry store last year at Athens, Pa., and who afterwards worked for E. W. Davies, of that town, died at his home near Ulster recently.

T. Lande, 402 E. Water st., Elmira, N. Y., is visiting New York to purchase a stock of jewelers' and watchmakers' tools. He intends to open a wholesale department for the sale of these goods.

William Hart, Kirksville, Mo., who with several members of his family was badly injured at a fire which consumed his store and stock recently, still suffers from the accident, being unable to walk, but the bones in his broken leg are uniting slowly.

The alterations to be effected in the factory of the Pairpoint Manufacturing Company, at New Bedford, Mass., will give the company one of the largest plants of its kind in the world, and the capacity for work will be nearly doubled. Where 350 hands are now employed, nearly 700 will be needed in future.

The Washburn & Moen Manufacturing Company, makers of watch and clock springs, Worcester, Mass., announce officially that they have purchased between 800 and 1,000 acres of land adjoining the town of Waukegan, Ill., a few miles north of Chicago, and will begin work on their new manufacturing plant there this spring.

The Elgin Watch Case Company, of Elgin, Ill., have just finished setting up what is said to be the largest pair of rolls ever built. They are 15 inches in diameter and were manufactured at Newark, N. J. This concern is fast getting in shape for doing a large and successful watch case manufacturing business.

G. W. Cole's diamond parlor, No. 907 Sixteenth st., Denver, Col., has been equipped with machinery for fine jewelry work. By an ingenious arrangement everything requisite for this work is contained in a space six feet square and is run by an electric motor. W. D. Smith is manager. This firm made the first solid tea set manufactured west of Chicago.

Carelessness nearly caused a disastrous fire in W. W. Condon's store at Ocala, Fla., last week. A gentleman in the store lighted a cigar and threw the burning match into a barrel which he supposed empty, but which was half full of straw. An immediate blaze was the result. It was, however, extinguished without any damage other than the severe burning of Mr. Condon's hand.

The work of placing two new elevators into the Rockford (Ill.) Silver Plate works was last week completed. The elevators are manufactured by the Smith-Hill Machine Company, of Quincy, Ill., and are model contrivances. They are so arranged that it is impossible for an accident to happen; if a cable should break a pair of side arms would clinch the slides and effectually prevent the elevator from falling. The company already had an elevator in the works, but the increasing business demanded additional ones.

After the Inventory.

We have just completed our Inventory, and the whole stock has passed in review before our eye. We have rigidly culled the stock in every department, and this "spring house-cleaning" affords a notable opportunity to secure staple goods at from 10 to 75 per cent. below standard prices. In some cases, as in Watches, the reduction is owing to goods having been discontinued; in other cases, because of overstock; in other cases again, the purchase of an extraordinary quantity enables us to make an extraordinary price. Whatever the cause in each instance, the effect is that we are able to offer a very unusual inducement to those judicious jewelers who "know a good thing when they see it," in each of the Watch, Chain, Spectacle, Tool and Material Departments.

We have had printed a list of the goods, with the regular and the special prices, and will send it to any jeweler on application. It will likely pay you to take the trouble to send for it.

Bowman & Musser,

Importers and Jobbers,

Watches, Chains, Spectacles, Tools and Materials,
Lancaster, Pa.

R. M. Rankin, of Kearney, Neb., has sold out.

S. C. Hood, of Yarmouth, N. S., has given a bill of sale.

J. M. Earp has succeeded G. W. Pool at Lamar, Mo.

J. N. Flynn will resume business at Hagerstown, Md.

G. L. Glines sold out his store at Harrison, Ark., to A. C. Harley.

A. W. Bishop, Connellsville, Pa., has moved into his new building.

J. W. Clark, of Denver, Col., has given a chattel mortgage for \$400.

W. D. Foster, Mayfield, Ky., has made an assignment with liabilities of \$1,600.

S. Spitz removed last week from Santa Fé, N. M. to Albuquerque, same Territory.

James Myers, Poughkeepsie, N. Y., will remove shortly to 231 Main st., that city.

Henry Sonneman has started a watch repairing shop at 465 Pearl st., Albany, N. Y.

Russell Williams, Meriden, Conn., will establish a silver plating business at Denver, Col.

B. Norris, of B. Norris & Co., San Francisco, Cal., has discharged a mortgage for \$14,000.

The Toledo (O.) *Commercial* printed recently an excellent likeness and biographical sketch of Jacob J. Freeman, of that city.

A. E. Bentley, formerly gen'l manager of the Illinois Watch Co., has been appointed general western sales agent for the United States Watch Co., with headquarters in Chicago.

N. T. Fisk, of Lexington, Neb., assigned his stock and fixtures on the last day of February to Max Mayer & Bro., of Omaha, for a debt of \$600. The liabilities above the Mayer debt amount to about \$500, with little or no assets.

Henry, alias "Bill", Lowery was convicted in Judge Waddell's court in Media, Pa., on the 3d inst, for the larceny of watches and jewelry from Hubert Muller's store, Chester, Pa., on Christmas Eve. George Harris, an accomplice, pleaded guilty. Sentence on the pair was deferred.

Gooding Bros., Plymouth, Mass., are conducting business in the very same store where their grandfather started in the clock and spoon-making line away back in 1802. The business has been handed down through three generations; and what is just as remarkable, Mr. Gooding when at the bench sits on the very identical stool his grandfather used in 1802.

One of the oldest watchmakers in the country is Nathaniel Foster, of Newburyport, Mass., surviving partner of the late firm of N. & T. Foster, of that place, who retired from business a few years since after a partnership extending over a period of sixty-one years. He celebrated his ninety-third birthday a short time ago, and is still active and hearty.

The End of F. W. Gesswein's Murderer.

The closing act of the tragedy, begun over a year ago, when F. W. Gesswein was killed in his office at 39 John st., New York, by Christian J. Deyhle, was enacted last Sunday, in the death of the latter in the prison ward of Bellevue Hospital, where he had been confined, awaiting trial, since the murder. Mr. Gesswein was a dealer in jewelers' supplies, and Deyhle the inventor of the water lens, used by diamond setters and engravers. Deyhle claimed that Mr. Gesswein had sold the patent without paying him any royalty and when his request for \$500 with which to pay for his entrance into Old Men's Home was refused he shot Mr. Gesswein through the heart, as he was seated at his desk.

Deyhle was descended from a family of ivory carvers in Wurtemberg, Germany. His father was said to have been one of the most skilful carvers on ivory in Europe, and his grandfather designed and executed a historical figure in ivory that is now in possession of the royal house of Wurtemberg. When he arrived in America he worked for about twelve months in New York, and was then engaged to do high-class carving for Harvey & Ford, of Philadelphia, and remained in their employ two years. His work attracted the attention of Col. Holt, of Hartford, and he was employed there for fourteen years directing the carving on the ivory stocks of the Colt weapons. A notable piece of his work was the carving of the first and last battles of the Revolutionary war on a six-inch square piece of ivory. It was a gem, and won a first prize at the Paris Exhibition in 1867.

Another bit of carving done by Deyhle was a figure of Christ on a cross on a twelve-inch piece of ivory. Col. Colt presented the artist with a solid gold cup and caster in recognition of his rare skill. Deyhle returned to the city in 1873 and did all the fine carving for Grote & Son in East Fourteenth st. During the Centennial Exhibition several of his carvings were awarded premiums. Deyhle settled in Philadelphia in 1877 and executed some curious work in carving mythological figures and heroic characters, but he reaped little or no financial benefit from his labor.

He subsequently devoted two years working on his water lens, and his hopes of realizing a competency for the support of himself in his remaining years, were ended in murder and his death last Sunday in the hospital.

New Bedford, Mass.

T. A. Tripp, treasurer of the Pairpoint Mfg. Co., who has been confined to the house several days by illness, is convalescing.

Among the jewelry salesmen in town during the past week were, F. T. Whitney, F. H. Elliott, and C. H. Eberle, Boston, Mass., and W. C. Wales, New York.

C. W. Haskins, 20 Purchase st., who has been confined to his house for the past two weeks with pneumonia, is able to be out again and resume business.

Canada and the Provinces.

M. Cochenthaler is improving his St. James st. (Montreal), store.

A. R. Harmon, Montreal manager of Robbins & Appleton, has been in Boston for several days.

E. A. Moss, Moncton, N. B., has opened a jewelry store there and is selling off the stock of the defunct firm of M. Moss & Son. He will continue the business at the new stand.

A. Marks, 49 Sparks St., Ottawa, has installed in his establishment a dynamo for electroplating and is now doing gold, silver, nickel and copper plating.

The jewelry store and dwelling of A. Gordon, at Durham, Ont., was burned to the ground last week. The greater part of the stock and furniture was removed. Loss about \$3,000; insurance, \$2,000. The cause of the fire is unknown.

The Canadian elections are now over. Jewelry has been brought into the contest as a means of showing that capital is protected at the expense of the workingman, inasmuch as spades and shovels, forks and hoes are taxed about fifty per cent., while jewelry is taxed only at twenty per cent.

The losses by the recent disastrous fire at Quebec have just been adjusted. Seifert's jewelry stock in *Le Canadien* block had a narrow escape from total destruction. As it was the damage was confined to that done by fire and smoke to their store. The adjustment assesses the jeweler's losses at \$850.

Newark.

J. Edgar Simonson is in Detroit. Mr. Simonson is traveling in the interests of A. J. Hedges & Co., of New York City.

N. H. White, of N. H. White & Co., who is a resident of this city, is traveling south in the interests of his business. He will return in April.

Fifteen watches valued at \$100 were stolen from the store of K. Bertl, 46 Springfield ave., on Tuesday morning. A large stone had been thrown through the heavy plate glass window, making a large aperture.

Four men were arrested, late last night, charged with breaking into Mr. Bertl's store. Their names are George Daly, John Kinney, Felix McGovern and Richard Henley. The latter is an old offender. The prisoners denied having been in the rear of Bertl's place, but the shoes worn by three of them fitted the footprints in the snow, and they were committed in default of bail by Justice Rodrigo.

The stock of Albert Kalisch, 877 Broad st., is being sold at auction to satisfy the claims of a number of New York creditors. Mr. Kalisch's failure was announced last week. He is a jeweler of twenty years' standing. He told a CIRCULAR reporter that he would not continue in the jewelry business.

Providence.

H. A. Kirby, of Kirby, Mowry & Co., will sail for Europe on the 20th inst.

The Norton Specialty Co., have removed from 123 Summer st., to 363 Eddy st.

G. E. Luther and wife, of this city, sailed from New York Friday for Bermuda.

G. L. Vose is a member of the joint committee of the City Council on the July 4 celebration.

Hiram Howard has been admitted to membership in the Rhode Island Horse Breeders' Association.

A. L. Sweet was chosen chairman of the Sixth Ward at the Prohibitory caucuses on Thursday.

V. Germanhausen has severed his connection with Potter & Buffinton after a service of eight years.

C. T. Leonard & Co., 40 Potter st., are out of business. Mr. Leonard has returned to work at the bench.

Ardern Dewsnap, formerly of W. S. Godfrey & Co., has discharged two mortgages amounting to \$4,400.

The executor of the estate of the late James A. Thornton settled his account in the Municipal Court on Friday.

Doran & Co. have removed from 143 Summer st. to 363 Eddy st., in the shop formerly occupied by A. J. Wiley & Co.

The business of Hagan, Fuller & Co., has increased so rapidly that they are looking for more commodious quarters.

A new firm, Doyle & O'Connell have started in business at 121 Broad st. Both gentlemen are from the shop of W. G. Hopkins.

S. K. Merrell & Co. removed last week from Pawtuxet to 74 Chestnut st., and started up in their new quarters on Monday.

Thomas Davis, of Sackett, Davis & Co., who has been dangerously ill at his house from pneumonia is now reported convalescing.

E. C. Ostby, of Ostby & Barton, the well-known ring makers, 80 Clifford st., is on a pleasure trip to Washington, D. C., with his wife.

The numbers on Aborn st. have changed, thus altering the following addresses: T. F. Mullen from 12½ to 39, and C. M. Tucker from 11½ to 40.

A. C. Messler, formerly of John A. Mason & Co., afterwards Messler & Mason, is now traveling salesman for Henry Williams, and is in the West at the present time.

B. A. Ballou is about to erect a two and a-half story dwelling on Congdon st., opposite Prospect Terrace, the highest point of land in this city, at a cost of \$10,000.

C. G. Bloomer, Jr., has been appointed a member of the financial committee and Wm. Bloomer of the auditing committee of the recently organized Volunteer Hose Co., of Pawtuxet.

G. H. Holmes has been nominated as a member of the Republican city committee

from the Fourth ward, and W. B. Frost, a delegate to the Republican city convention, from the same ward.

H. S. Dorchester, of Brown & Dorchester represented the New England Manufacturing Jewelers' Board of Trade at the recent meeting of the creditors of Sumner Bros., of Cleveland, held in New York.

W. C. Burwell, who has been a teacher in the Classical Department of the Providence High School for several years, has resigned to enter the firm of J. B. & S. M. Knowles, assuming the interest of his father-in-law, the late Joseph B. Knowles.

Notwithstanding the severity of the weather during the past few weeks, work upon the new building of the Ladd Watch Case Co., corner Richmond and Clifford sts., is progressing very rapidly. The Ladd Company will occupy the basement and lower floor.

Wednesday was the centennial of Vermont's admission to the Union, and the Sons of Vermont in this city celebrated the event in an appropriate manner. Fred I. Marcy, the well-known manufacturing jeweler, is president of the Association and was present with his wife.

The item published in this department, in the issue of Feb. 25, to the effect that John Klipper, of New Orleans, was in town trying to make a settlement with his creditors, was erroneous. The writer had in mind John Tabor, of Dallas, Texas, but, having mislaid his notes, and having seen Mr. Klipper in the city, and both gentlemen coming from the South, he confounded their names.

The Kent & Stanley Co. has been incorporated with a capital of \$300,000, all paid in. A. W. Stanley is president, E. F. Kent, treasurer and general manager, and J. D. Warren, secretary. Among the stock holders are large capitalists of this city and New York. This change has been made necessary by

the great increase of business of Kent & Stanley, which has been in a measure due to the rage for their "Seamless" chains.

Dr. de Dudley, who from a twenty years, medical practice in the Orient has acquired many rich and magnificent examples of the handiwork of the natives of India, showed certain of his most remarkable bric-a-brac a few evenings ago at the office of J. A. Shirley. The most valuable was a bronze representation of Dourga, one of the forms of the Brahmin virgin, which is probably 5,000 years old. It was dug from the buried city of Brahma Pooora, in upper India. The doctor possesses a star stone—a creamy jewel which in the sunlight emits soft rays like a star—that is extremely rare, and almost priceless. An exquisitely wrought hammered silver salver is also in his collection, which numbers upwards of 200 articles.

Pittsburg.

Traveling men who have visited Canton, O., say the Dueber factory at that place is running to its full capacity.

G. B. Barrett fell on the icy sidewalk near his home on Montgomery ave., Alleghany, one day last week, and broke his arm.

The Pittsburg Reduction Co. has begun another suit for infringement against the Cowles Smelting Co., of Cleveland, O.

A window that attracts much attention is that of R. Siedle & Sons, on 5th ave. It is kept full of souvenir spoons, comprising many rich and unique designs. The rage for these articles seems to be at its height in Pittsburg just now.

Durbin & McWatty, of 5th ave, have been given an order for an elegant miniature silver billiard table, to be competed for at the billiard tournament soon to take place in this city. It will be set with diamonds, and will be a very handsome prize.

WATCH DIALS.

Any kind watch dial duplicated within ten days. Factories supplied with dials for their entire product or with special designs for their high grade movements. Special rates for large quantities. Emblems, photographs, landscapes and ornamental work of every description on plain, enamel or under glaze.

**WALTHAM DIAL CO.,
WALTHAM, MASS.**

A. RICKERT. C.A. STIEHLE.
RICKERT & STIEHLE,
MANUFACTURERS OF
GOLD CHAINS,
SWIVELS AND SPRING RINGS.
Chain Repairing a Specialty.
13 & 15 Franklin Street. NEWARK, N. J.

HAYDEN W. WHEELER & CO.,

IMPORTERS OF



Manufacturers of DIAMOND JEWELRY,

2 Maiden Lane, New York.

LONDON, 50 HOLBORN VIADUCT.

Mrs. W. Fitch, daughter of the late Gen. Sherman, who lives in this city, will, it is said, dispose of the jewels given her by the Khedive of Egypt at the time of her marriage. Her share of the diamonds is said to be worth \$35,000, the total value being about \$135,000. They were divided equally among the General's children.

St. Louis.

J. W. Stumpf, manager for C. Boehmer & Co., 511 Franklin ave., will open a jewelry store on his own account, in the same block this month.

The Mermod-Jaccard Jewelry Co. will, at their annual meeting on April 16, vote on a proposition to increase the capital stock from \$400,000 to \$500,000.

August Hettel, who has kept a little establishment at 402 Morgan st. since 1851, is preparing to retire permanently from business. Mr. Hettel has never moved his stock from the little room where he first began business on his arrival from Germany forty years ago. Failing sight is the reason for giving up business.

The following traveling men registered at the Mermod-Jaccard Jewelry Co. last week: A. R. Vermilyea, of the Bradley & Hubbard Mfg. Co., Meriden, Conn. J. J. Metcalf, of R. Blackington & Co., N. Attleboro, Mass. W. W. Hayden, of L. W. Fairchild & Co., New York. W. T. Gough, of Carter, Sloan & Co., New York. Louis E. Fay, of Kirby Mowry & Co., Providence, R. I.

The "Diamond King," whose right name is Joe Samuels, has been brought back to this city from Chicago. "Diamond Joe" is wanted on several charges of grand larceny, he having been accused of having swindled several jewelers and time-payment houses out of \$2,000. He was arrested, tried and convicted, but appealed, and while the appeal was pending he swindled several jewelers out of \$300 in diamonds and left the city.

Merrick, Walsh & Phelps have begun to completely overhaul their already fine show rooms at 511 Oliver st. They intend to fit up the third story of their building as a clock department and devote the first floor entirely to the display of fine goods, solid silverware and novelties. The office will be removed from the front to the rear of the room, and the counters will be carried clear back. It will take nearly a month to complete the repairs.

Detectives Tracy and Archimbault have learned that the man who robbed P. N. F. Schmidt, some days ago, hired the horse and buggy at a livery stable at Second st. and Chouteau ave., depositing \$1 on the rig, and giving his name as George Meditho. A search of the pawnshops on Fourth st. by the same detectives discovered one of the watches, which had been pawned for \$20. The watch was worth \$90. The police have no clue as yet as to the thief.

Kansas City.

V. G. Cuthbert, of Otto Young & Co., Chicago, is spending a few days at his home in this city.

A. Hosier, with Cady & Olmstead, has an heir to his estates in Texas, who is now in its 9th day.

E. Massa, of the Bauman-Massa Jewelers' Supply Co., St. Louis, called on his friends in the city last week.

While in transit from the Meriden Silver Plate Co., Meriden, Conn., to C. E. Russell a box of silverware was "tapped" for about \$50. The railroad company made good the loss.

George W. Shepardson, for the Gorham Mfg. Co., is in the city on his way to Denver, Col. Ferguson Mead, of E. G. Webster & Son, Brooklyn, N. Y., was in the city last week. He said he obtained orders through the North and West.

The following salesmen were in the city last week: A. L. Blankenmeister, of the Hartford Silver Plate Co., Hartford, Conn., Jack Stanley, of the Meriden Silver Plate Co., Meriden, Conn., Tom Davis, Middletown Plate Co., Middletown, Conn., Mr. Ashton of Kent & Stanley Co., Providence, F. A. Frey, of A. F. Towle & Co., Greenfield, Mass., and Robert Welch, of Welch & Miller, V. W. Brundage, of Leroy W. Fairchild & Co., S. Englander, of Henry Dreyfus & Co., F. Horton, of Carter, Sloan & Co., New York.

Boston.

O. A. Drinkwater, of Morrill Bros. & Co., will take a trip South for his health.

A. H. Potter & Co. will move to their new location, 567 Washington st., about April 1.

E. H. Harnden, manager of the American Watch Co.'s office in the city was confined to the house last week for several days with the grippe.

Mr. Shaler, agent of the Meriden Cutlery Co., will have his Boston headquarters at 421 Washington st., in the store of J. N. Lindsay & Co.

Treasurer R. E. Robbins, of the American Watch Co., started on Thursday last for St. Augustine, Fla., where he will enjoy a brief vacation with his family.

Among the travelers in town the past week were: Col. Stevens, of the Brooklyn Watch Case Co., T. Fessenden, F. Sherry, J. Friedman, S. Levy, New York; J. W. Phillips, Philadelphia; H. B. Beach, Meriden, Conn.

The New England members of the National Association of Jobbers in American Watches last Tuesday elected their officers as follows: Executive, A. Paul; Secretary and treasurer, Irving Smith; application committee, A. Paul, C. Harwood, and D. C. Percival.

E. B. Horn, for thirteen years in the jewelry business, at 429 Washington st, has sold out to C. A. Woodsome, who was formerly Mr. Horn's salesman for eight years. Mr. Horn will engage in the real estate business for the present.

San Francisco.

The latest fad in jewelry in this city is the jeweled breast-pin.

Business is looking up throughout the state. The local retail trade has materially improved during the past two weeks.

F. D. Higginbotham, traveler for Henry Wolf, 120 Sutter st., has returned from a six weeks' trip through Southern California.

The West Coast Jewelry Co. were severely reprimanded by Police Judge Rix, a few days ago, for trying to use the courts for the collection of debts due for goods sold on the installment plan.

Local jewelers have been interviewed on a newspaper circulation bill now pending in the State legislature. Long interviews with T. Lundy, 7 Third st., and Julius Van Vliet, 752 Market st., were printed.

The Jewelers' League.

At the monthly meeting of the Executive Committee of the Jewelers' League, held on Friday, there were present Vice-President Greason and Messrs. Howe, Bardel, Jeannot, Untermeyer and Sexton.

Two applications for membership were rejected, three were referred for investigation, six requests for change of beneficiary were granted and the following applicants were accepted: R. F. Hardy, Pittsburg, Pa., recommended by W. F. Hofman and O. Heeren; O. J. Harris, Brooklyn, N. Y., recommended by A. Hodenpyl and C. J. Fox; C. R. Jung, New York City, recommended by C. J. Fox; C. M. Lazarus, New Orleans, La., recommended by A. M. Hill and L. Krower; S. Leventhal, Hartford, Conn., recommended by S. Steiner and F. Leventhal; H. Maier, Alleghany, Pa., recommended by J. R. Steinmann and E. J. Rubb; H. E. Perkins, Binghamton, N. Y., recommended by W. J. Eroo and C. W. Russell; H. A. Reineman, McKeesport, Pa. recommended by A. K. Sloan and Wm. Bardel; H. Rose, N. Y. City, recommended by D. and H. Untermeyer; J. Rosenfeld, New York City, recommended by L. Tannenbaum and S. Dessau; L. L. Squire, New York, recommended by J. O. Slemmons and F. S. Baker; M. Stern, New York, recommended by J. J. Cohn and B. Spier; T. Watson, New York, recommended by C. F. Egger and J. Wennstrom; J. B. Yates, recommended by S. DeBear and F. S. Baker.

Henry Ginnel & Co., 31 Maiden Lane, New York, are general agents for Ezra Kelley's watch, clock and chronometer oils. These oils need at this late day no word of praise. Every watch and clock maker knows their superior qualities as well as he does the use of an escapement; still they should read the announcement on another page in reference to these oils.

SEE OUR INDUCEMENTS TO NEW SUBSCRIBERS ON PAGES 30 AND 31.

Cincinnati.

Joseph Hellebush is sick, and will take a rest.

Ignatius Hengge, 551 Main st. has given up business.

A. Herman is still kept off the road with his eye trouble.

Louis Albert, of the new firm of Albert Bros., is in the East buying goods. The firm expects to be in shape to begin business by the 20th.

Lee Kaufman is on the road hustling after diamond customers. He came home for a few days, but declared that he sold goods in every town he visited.

The eccentric mania for "heavy weight" watches is on the increase. D. Schroder & Co. recently filled an order for a solid gold 18 karat hunting case, weighing 160 pwt.

Jonas, Dorst & Co. are preparing for the medal season that opens about the end of this month. Mr. Jonas is getting ready a big lot of designs to meet the medium and cheap goods trade.

John Holland has returned from the East. He says that the iridium scales he placed in the Treasury Department at Washington are giving complete satisfaction. They have stood a test of five weeks with no variation.

I. N. Laboiteux, local manager of Duhme & Co., has hit upon another clever attraction for his newspaper advertising. With a mind well stored with the best authors he has been selecting quotations from them bearing on each article advertised. Duhme & Co. are making a special offer of hall clocks, and it is very fitting to quote Longfellow on "The Clock in the Hall."

Frank Trummel, who has been just released from prison for passing bogus checks, went into Herschede's jewelry store last week, and representing himself to be the local agent for the C., H. & D. R. R. Co., selected a fine ring, and offered a check in payment. Fortunately, one of the salesmen recognized him, and notified the proprietor, who promptly sent for an officer, who took him in charge.

Homan & Co., silver plate manufacturers are doubling their force. This sounds unreasonable for this time of the year, but their new improvements have given them more room. They are now beginning on their new novelties to catch the trade this year. They intend to make up a big line for future shipments. The prettiest fancies are the individual butters, in imitation of French china, which will be sold in sets in velvet cases.

Transatlantic Passengers.

Among the passengers who sailed to Europe during the past week were R. L. Boyd, of Boyd & Abbot Co., Henry S. Oppenheimer, of Oppenheimer Bros. & Veith, and William Maas, of Wm. Maas & Co., on the *Spree*; Louis Neresheimer on the *Aller*, and Frederick Goldsmith on the *Umbria*, Alfred Krower, of A. Lorsch & Co., sails to-day on the *Lahn*.

A Bogus Check Utterer Sentenced.

CLEVELAND, O., March 8.—The case of H. W. Schmidt, alias C. H. W. Smith, who obtained a pair of diamond earrings and a diamond stud from Webb C. Ball's clerk, by giving in payment a check on the Euclid Avenue National Bank, was brought up in Court yesterday morning. The defendant is young, and rather more respectable in ap-

pearance than the ordinary criminal. He burst into tears, and declared that he was on his way back to Ball's store to return the diamonds when he was arrested. He was sentenced to two years in the penitentiary.

H. C. Thurgate, Kansas City, Kan., has given a chattel mortgage for \$192.



EXAMPLES OF CLASS PINS (COPYRIGHTED 1891), DESIGNED AND MADE BY HENRY C. HASKELL, 11 JOHN STREET. PLATES SENT TO DEALERS UPON REQUEST.

SOMETHING • NEW.

ALUMINUM THIMBLES.

Light, Durable and will not tarnish.

In appearance similar to Silver, and at half the cost.



If you want something *NEW*, *HANDSOME* and *CHEAP*, send, enclosing business card, for samples and prices.

KETCHAM & McDOUGALL,

198 Broadway, New York.

JOHN B. YATES,

No. 147 NASSAU STREET, NEW YORK.

WATCHES

SPECIALTIES: UNITED STATES WATCHES.

I have a limited number of Discontinued American Waltham Gilt Hunting, price formerly \$12.65, same grade as the "Taylor" (Elgin) Movement, for \$10.50 Net.

Chicago.

E. L. Johnson is at Hot Springs, Ark.

Henry Freund, of New York, was in the city last week.

C. R. Underwood, Racine, Wis., was in the city last week.

L. Flershem will return this week from a pleasure trip in the South.

Most of the jewelry houses are preparing for their regular spring house-cleaning.

Chambers & Inskey, manufacturing opticians' lost \$450 by fire last week.

C. O. Swinning, has removed from the west side, and is now located on State st.

F. F. Sheridan, master mechanic of the Illinois Watch Co., was in town last week.

S. Dripp with Benj. Allen & Co., has returned from a very successful Southern trip.

W. Meacham, of the Meriden Britannia Co., has returned from a business trip in the East.

Mr. Manson, of Mendota, this State, was in town the past week. Mr. Hastings, of Winona, Min., was also here.

A. W. Sproehle, of the A. W. Sproehle & Co., met with a distressing bereavement last week in the loss of his little baby girl. The sympathy of the entire trade is extended to him and his sorrow-stricken family.

About as apt a way to illustrate the "big heart" that seems to pervade the Chicago Jewelers' Association and their entertainments, is furnished when it is said that in round numbers their recent annual banquet cost \$1,800.

W. F. MacDonough, the genial representative of the Courvoisier Wilcox Mfg. Co., visited the trade of this city last week. It is said he met with good business and that the new 10-K. gold cases the Company have recently put upon the market were favorably received.

The Excelsior Sign Co., L. S. Grout manager, which for four years has been located at 124 Dearborn st., will the 1st of May remove to 56, at the head of State st. This concern has always been very popular with the jewelers of the country. In choosing new quarters, other than trying to be centrally located, their aim has been to secure more which rapidly increasing business has made imperative.

On Tuesday, March 3d, the resident members of the National Association of Jobbers in American Watches, met to elect two members who will control the destinies to a certain extent of all business of importance pertaining to this city, that will eventually come before the National Association. Benj. Allen and C. F. Happel, who served in like capacity last year, were unanimously elected. Their past deliberations met with so much favor that they had no competitors for the positions.

The Chicago Jewelers' Association held their regular monthly meeting, Tuesday last. In the absence of President Burchard, Vice-President Sercomb presided. There

were no matters of importance brought up for consideration. The Banquet Committee's report was accepted and the gentlemen composing that committee, after being highly commended for their services were discharged. This was Mr. Sercomb's first experience with handling the gavel, but it is said he acquitted himself with distinction.

Suicide of a Nobleman's Son.

CHICAGO, Ill., March 9.—Arvid Erickson, the son of a Swedish nobleman, committed suicide by shooting himself through the heart this afternoon. Erickson came to Chicago, August 2 last, and immediately obtained employment from Charles Williams, a manufacturing jeweler in Kensington. His act is believed to have been caused by a love affair.

The McBride & Marcellus Failure in Court.

CLEVELAND, O., March 7.—W. E. Webster & Co., of Providence, R. I., on Thursday replevined \$400 in gold rings from O. J. Campbell, receiver of the McBride & Marcellus Co. The rings were consigned to the Akron branch, where the receiver was fortunate enough to secure possession before the holder of the judgment note.

Rogers & Brother filed an answer and cross-petition Thursday in the suit in which the receiver was appointed, setting up a claim for \$444.44 and asking that a receiver be appointed. Assignee Gibbons filed a motion yesterday to discharge the receiver. His reasons were, first, that Mr. Marcellus' petition does not state facts sufficient to warrant the appointment of the receiver and second, that he is disqualified as a receiver because he "is one of Mr. Marcellus' attorneys." M. W. Beacom is Mr. Marcellus' attorney in the records of the court.

Hamilton & Hamilton, Jr., of Providence, R. I., and C. Rogers & Bros., of Meriden, Conn., filed claims yesterday for \$805 and \$857.52 respectively. Both firms ask the confirmation of the receiver. The contest over the Company's failure was brought into court this morning for adjudication. As the hearing was about to begin Judge Dickey for McBride and Attorney J. G. White got into an argument on the point, whether the entire matter be heard or only the motion to continue the receiver. Judge Noble finally decided in Mr. White's favor. It was thereupon arranged that the official life of the receiver that was to end at noon should be prolonged until the motion to continue him should be heard and decided; and that afterward the motion to remove him should be at once taken up.

M. W. Beacom, for Marcellus, then proceeded to read the affidavit of the McBride & Marcellus Co.'s book-keeper, showing the financial embarrassment of the corporation when Marcellus filed the petition in which Receiver Campbell was appointed.

Judge Dickey stated, when the hearing of his motion was being urged, that a march

had been stolen by Mr. Marcellus in getting a receiver appointed without notice.

Attorney F. E. Dellenbaugh says that Carpenter & Young's man who went to Akron to replevin the rings for W. E. Webster & Co., of Providence, R. I., from the branch store, did not find the rings and only about \$1,000 of stock instead of \$20,000 that he expected to find.

Last Thursday the firm made an assignment to James Gibbons. This makes three parties claiming rights.

Philadelphia.

Simon Muhr, who is President of the Jewish Alliance of America, delivered an address in German at the annual meeting of the Philadelphia Branch, on March 1st.

Buhel Bros. are erecting a large brick building at 21st st. and Reading Railroad, to provide necessary additional accommodations for their brass and copper statuette manufactory.

Louis Bowden, of J. B. Bowden & Co., New York, has made a departure from his usual methods, and has started on a trip himself, combining business with pleasure. He was in Philadelphia on the 6th.

There were many jewelers' representatives in the city during the past week; among them were Charles Gallagher, of Sinnock & Sherrill, New York; Mr. Perry, of the Aurora Watch Co., Aurora, Ill., and William Wightman, of R. F. Simmons & Co., Attleboro Falls, Mass.

C. S. Powell, formerly at 631 Chestnut st., who recently opened a large retail store on 8th st., below Market, has fitted up the place in elegant style. One of the features of the new store is a very large bulk window, in which is displayed a magnificent assortment of jewelry and gems.

The big fire at J. O. Schimmel's fruit preserving establishment in Eighth and Berks sts., last week, will cause C. J. Scherr, of Louis A. Scherr & Co., who lives at No. 1919 North Eighth st., to seek another residence. As his house is within a few doors of the scene of the fire, it was soon filled with smoke and flying cinders.

Bailey, Banks & Biddle, whose immense store is always attractive, have further beautified their art rooms. The latter is a large apartment in the rear of the first floor, and about it the firm has tastefully arranged piano lamps of various designs, together with rare and beautiful clocks, tables, ornaments, etc. The whole is effectively enhanced in beauty by draperies.

The well-known firm of A. Ledig & Son, manufacturers of silver, nickel, brass, copper and bronze goods of every description, N. 8th st., has been dissolved by the retirement of A. Ledig and R. A. Ledig from active partnership. The business will be continued under the style of Ledig & Way, by C. W. Ledig and Joseph Way, general partners, and A. Ledig and R. A. Ledig, special partners.

To Substitute a Trustee for Assignee Graham.

CLEVELAND, O., March 5.—The Roy Watch Case Co., New York, who have a claim against Sumner Bros. to the amount of \$1,000, has petitioned the Probate Court to authorize the appointment of a trustee to take the place of T. H. Graham, the present assignee.

The applicant company are joined in the application by the Waterbury Clock Co. with a claim for \$709.14, and Wm. Smith & Co., New York, with one for \$7,283.84.

A Much Talked-of Diamond.

Everybody about the office of J. W. Carroll a lithographer of Duane st., New York, last Monday talked diamonds. Two days previous he had received an alleged pure orange-colored diamond from a dealer in Montreal, and he was showing it with pride to every caller. He said that it was found in 1884 at Kimberley and that in 1887 the ladies of Queen Victoria's court bought it, and presented it to the Queen as a souvenir of the Jubilee. But she wouldn't receive it, and it was sold to a London jeweler. The money, at the Queen's suggestion, was given to a hospital in her name. R. S. Lawrence, an American from Colorado, bought the stone from the jeweler and sold it in January last to Edward Bruce in London, and Mr. Carroll bought it from Bruce in Montreal. He values the stone at \$70,000 and says it weighs 115 karats. To a CIRCULAR reporter who examined the gem he said he had received a request from Mrs. McK. Twombly to see the stone and was going to endeavor to sell it into the Vanderbilt family of which she is a member.

George F. Kunz, of Tiffany & Co., said to a reporter: "I had the 'orange stone' in my hands at the Exposition, and am thoroughly familiar with it. It is a brilliant weighing about 110 karats, and was at that time the property of a Mr. Baird in London. I have no advices as to its having passed out of its then owner's possession. So far from the stone in question being the third largest in the world, there are a number of well-known gems that surpass it in weight. Even at 115 karats it would rank no higher than tenth or twelfth in size."

An expert who has seen the stone says that it is not a pure orange brilliant, but simply an off-colored diamond of extraordinary size.

Gen. Geo. H. Ford's Enterprise.

NEW HAVEN, Conn., March 7.—An important New Haven business transaction which is specially interesting to the jewelry trade, was consummated to-day. To THE CIRCULAR's correspondent Gen. Geo. H. Ford stated that he had to-day purchased for \$75,000 the Simpson block, one of the most centrally located buildings for mercantile purposes in this city. Gen. Ford's elegant store is in this building. He has for years had control of the entire building as lessee, subletting the other stores and various offices.

The General bought the building of Hon. Samuel Simpson, of Wallingford, the head of

the firm of Simpson, Hall, Miller & Co., who has owned it for many years. He takes full possession May 1, on the expiration of his lease. He will make a radical change in his business, and will greatly improve the building. On May 1, Gen. Ford's jewelry business will be formed into a joint stock company, and he will take into partnership some of the young men connected with his estab-

lishment. The commodious store on the east side will be merged with the present Ford store, and the new company will occupy the entire ground floor as well as most of the second floor of the building.

SEE OUR INDUCEMENTS TO NEW SUBSCRIBERS ON PAGES 30 AND 31.

N. KOCH. L. DREYFUS. J. KOCH. I. PFORZHEIMER.

KOCH & DREYFUS,

22 John Street, New York.

IMPORTERS OF DIAMONDS,

JOBBER'S OF

AMERICAN WATCHES,

Diamond Novelties and Jewelry.

We have now a complete line of Goods and Specialties on hand and on the road in charge of following representatives:

JAMES KOCH, GEO. MALLET, L. GOLDSMITH,
HENRY HEYMAN, A. ROSENTHAL.

THE LATEST PARISIAN NOVELTY.



MANUFACTURED BY
CROSSIN & TUCKER,
409 Pine Street, Providence, R. I.

WOOD & HUGHES,
Sterling Silverware Manufacturers.
New York Agents for the Derby Silver Co.'s
FINE QUADRUPLED PLATED WARE.
No. 16 JOHN STREET, - NEW YORK.
206 Kearney St., San Francisco, Cal.
HASKELL & MUEGGE, Agents.

HENRY ERBSMEHL,

WATCHMAKER & JEWELER,

Watches, Clocks, Jewelry and Silverware.

MILFORD, DEL., March 4th, 1891.

MESSRS. R. & L. FRIEDLANDER, New York City.

GENTLEMEN: It gives me pleasure to recommend to the trade your Monarch Main Springs, for American Watches. They are, without exception, the best Main Springs that I have ever used. I have tried all makes within the last 25 years, but have found none equal to the Monarch Springs. They are uniform in force and temper; out of 6 dozen springs, I have lost but two.

I remain, yours truly,

HENRY ERBSMEHL.

GORHAM MFG. CO.

Silversmiths.

SOLID SILVERWARE.

Manufacture and carry in stock the largest assortment of Solid Silver Ware to be found in the country, including specimens of art work of the most elaborate and costly design, as well as articles of plainer and more simple forms suitable for household use.

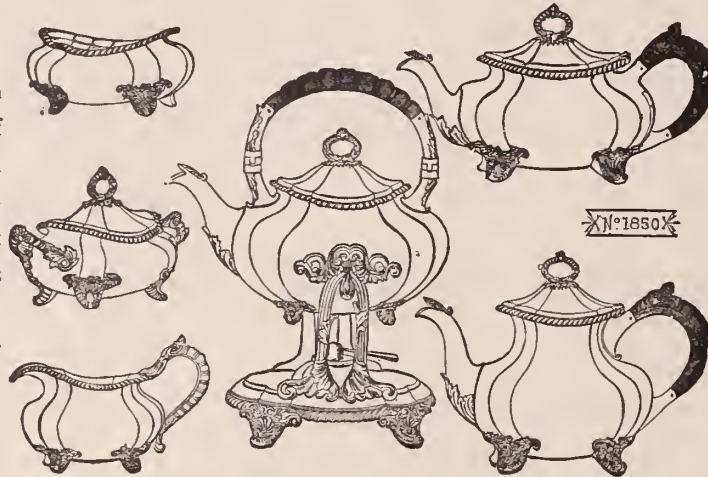

Gorham Mfg. Co.'s Branch Houses:
 9 Maiden Lane, N. Y.
 137 & 139 State St., Chic., Ill.
 120 Sutter St., San Fran., Cal.
 36 Avenue de l'Opera, Paris,
 France.

WORKS: PROVIDENCE, R. I.

ALL COMMUNICATIONS SHOULD BE ADDRESSED,

Broadway and 19th St., New York.

ALFRED H. SMITH & CO.,

DIAMONDS,

182 BROADWAY,

COR. JOHN STREET,

NEW YORK.

33 HOLBORN VIADUCT, LONDON, E. C.

THE JEWELERS' CIRCULAR AND HOROLOGICAL REVIEW.

PUBLISHED EVERY WEDNESDAY BY

THE JEWELERS' CIRCULAR PUB'G CO.,
AT NO. 189 BROADWAY, NEW YORK CITY.

A JOURNAL DEVOTED TO THE INTERESTS OF
WATCHMAKERS, JEWELERS, SILVERSMITHS,
ELECTRO-PLATE MANUFACTURERS AND ALL
WHO ARE ENGAGED IN KINDRED BRANCHES
OF INDUSTRY.

Terms of Subscription, Postage Prepaid.

	PER ANNUM
United States and Canada, - - -	\$2.00
To all Foreign Countries, - - -	4.00
Single Copies, - - - - -	.10

ADVERTISEMENT.

Business letters, drafts, checks and post-office orders should be addressed to THE JEWELERS' CIRCULAR PUBLISHING COMPANY, No. 189 Broadway, New York city.

Manuscript from any quarter containing news or discussion of any technical subject within the field covered by THE CIRCULAR will be welcomed. Matter received that proves unsuitable or unavailable will be returned if accompanied by the necessary postage stamps.

Our editorial columns will contain our own opinions only, and we shall present in other columns only what we consider of interest or value to our readers. Applications to print advertising matter as news will not be considered.

Advertising rates in THE CIRCULAR are lower, considering the number of tradesmen reached by its large circulation, than in any other jewelry journal.

Notices of changes in standing advertisements must be received one week in advance, new matter can be received up to Saturday.

Member of the American Trade Press Association.

CLASSIFIED INDEX TO ADVERTISERS, PAGE 28.

VOL. XXII. MARCH II, 1891. No. 6.

Work of the 51st Congress. IN few Congresses of recent times has the bulk of legislative work done been so voluminous as that performed by the Fifty-First Congress, that went out last Wednesday. In the past two years, among the multifarious measures brought up, were three whose hearing was direct on the progress of every branch of commerce and industry. These were the McKinley Tariff law, the Silver Purchase act and the Bankruptcy bill, the first two of which were placed upon the statute. While the enactment of the first mentioned had a temporary depressing effect upon the trade in some lines, among which were bronzes, porcelains, fancy goods, etc., by reason of an uncertainty in the minds of country dealers whether the bill would last its time or be declared void in a few months, the aggregate of imports and exports in 1890 exceeded that of 1889 by \$83,000,000, and it must be presumed that the volume of each class of import goods was proportionately increased. The Silver bill influenced especially the silverware trade. The manufacturers of sterling silverware, as the price of bullion rose, advanced their prices in accordance only, and as it decreased

reduced them. Thus the effort on the trade was only to slightly advance the standard of silverware. The measure was a mistake of Congress, but its only baneful effect upon the jewelry trade was to give it temporary worry. The Torrey Bankruptcy bill, we agree with numerous representatives of commerce throughout the country, is a worthy measure and its failure to pass the Senate was a disappointment.

Is the Tariff Act Constitutional?

THE appeals in the cases brought by several large mercantile houses of the country to test the constitutionality of the McKinley Tariff law have already reached the Supreme Court, and been adjourned till April. The principal grounds upon which it is contended that the bill is unconstitutional, are first, that the bill signed by President Harrison was not the bill that passed both houses of Congress, a section having been omitted in its engrossment; second, that it contains provisions for bounties to sugar producers in this country, which under the Constitution, Congress had no power to enact; and third, that section 3 of the Act assumes to delegate to the President the power to impose taxes upon imports, which power is vested exclusively in Congress, and cannot be delegated. Though it is unlikely that the merchants will win their cases, all interested in trade or commerce feel it to be imperative that the matter be speedily settled.

Missouri Onyx Discoveries.

OUR correspondent in St. Louis writes as enthusiastically on the subject of the deposits of onyx in Pulaski and Crawford Counties, Missouri, as the prospectors speak. The mineral was discovered some months ago, and created a sensation at the time. Since then, specimens have been submitted to experts, who have bestowed little praise upon them; but as the character of the working and polishing of the stone is an important factor in disclosing its beauties, the claims of Mr. Reynolds are worthy consideration. It is natural that the prospector should be over-enthusiastic in his claims; he is like the inventor who considers his device the one in the world. Allowing for this, we know that the almost boundless territory of the country may yield up treasures at any moment, and under each unprospected spot an El Dorado may exist. The matter, therefore, should be investigated by every one interested.

Leniency to Connors.

OUR Newark correspondent states that Andrew Connors, sentenced to thirty years' imprisonment for committing one of the most reckless crimes in the history of burglary, is petitioning for a pardon after serving one-third of his term. All jewelers will desire that the sentence be carried out to the letter; not because the criminal may return to his old business, but because the

leniency will be remembered by men of his class. The subject of punishment for criminal offences is many-sided; but all civilized nations believe it to be a means of prevention. The knowledge of certain capture sooner or later, with long and arduous imprisonment, must to some extent deter the evil-minded; and jewelers who are the victims of assault and theft, more than any other class of merchants, seek all the protection the law can give them.

The Week in Brief.

M. S. Smith, of Detroit, Mich., is convalescing after a paining operation. — The Manhattan Silver Plate Co. may move from Lyons, N. Y. — W. E. Cross, Amsterdam, N. Y., was robbed. — Prof. Willimot lectured at Ottawa, Ont., on the gem resources of Canada. — Three thieves robbed Nathan Block, of Chicago, Ill. — Andrew Connors who is serving a thirty years' sentence for robbing Traphagen's jewelry store in Newark, N. J., petitions for a pardon. — The Dueber Watch Case Works resumed active operations. — The Jaccard Watch and Jewelry Co., Kansas City, Mo., elected new officers. — C. G. Hall, Hartford, Conn, filed his schedule. — The Missouri onyx deposits again claimed attention at St. Louis. — An Ithaca (N. Y.) dealer failed. — A scandal was caused at Cheyenne, Wyo., by the changing of the design of the State seal. — The suit of L. Tannenbaum & Co., New York, against W. J. Knowlton, Boston, Mass, came up in the Supreme Court of Boston. — The mortgages of C. R. Hollis, La Grange, Ind., were set aside. — J. C. Tilton, Davenport, Ia., recovered a long lost jewel. — Fire burnt out jewelers at Des Moines, Ia. — 2,000 shares of the Lancaster Watch Co. were sold for \$75. — The old Terry church clock at Terryville, Conn., stopped for the first time in fifty years. — Washburn & Moen Mfg. Co. have purchased a large tract of land in Illinois for the erection of a new factory. — The Rockford (Ill) Silver Plate Co. have improved their facilities — Kent & Stanley, Providence, have incorporated their business into the Kent & Stanley Co. — W. C. Burwell assumed the interests of the late Joseph B. Knowles, in the house of J. B. & S. M. Knowles. — The Chicago branch of the N. A. of Jobbers in American Watches held an election. — The Mermod-Jaccard Jewelry Co., St. Louis, Mo., propose to increase their capital stock. — The Jewelers' League held its monthly meeting. — The Chicago Jewelers' Association held their regular monthly meeting. — The McBride & Marcellus Co. failure came up in court at Cleveland, O. — Jos. Fahys & Co., New York, have opened a Pacific Coast department at San Francisco.

The banquet of the Boston Jewelers' club will take place to-morrow night.

New York Notes.

I. Pforzheimer has been admitted into partnership by Koch & Dreyfus.

M. D. Cohn, with I. Michelson & Co., last Monday started on an extended trip to the far West.

J. P. Delany, whose store is under the Astor House, is suffering from pneumonia at his home in Brooklyn.

J. J. Levy, formerly with S. C. Powell, of 51 Maiden Lane, has started in business for himself in the same building.

Frank Mauser, of Frank Mauser & Co., 30 Union Square, last week, while on the road, visited his brother, George Mauser, at Knoxville, Tenn.

August Schaffer has retired from the firm of Hahn & Co., 41 Maiden Lane, and has started in the diamond business for himself in the same office.

The suit of Hodenpyl & Sons against L. Tannenbaum & Co., when called in Part II., Special Term of the Supreme Court, last Friday, was adjourned until March 10th.

Henry F. Lommers, alias Henry Lewis, who was stopping at the Bancroft House, was arrested last Thursday. He is wanted in Chicago, where it is alleged he absconded with \$1,200 from L. Manasse, optician. He has been committed to await a requisition.

To morrow afternoon the Board of Directors of the New York Jewelers, Board will meet for the purpose of electing a lawyer to represent them in place of G. C. Comstock.

Jos. Fahys & Co. have opened a branch house in San Francisco, from whence the Pacific Trade will be supplied. John Serex, formerly with the Essex Watch Case Co., has charge of the new department.

Bourke & Marx are making extensive alterations to their establishment at 141 Centre street. The office has been moved from the top floor to the first floor, where salesrooms and storerooms are now being fitted.

Last Thursday James Russell and Charles Morrell, indicted on the charge of larceny of goods from Isidor Kottl, 1598 Ave. A, were arraigned before Judge Fitzgerald in the Court of General Sessions; they both pleaded guilty and were each sentenced to State Prison for four years and two months.

Sec'y H. M. Condit, of the New York Jewelers' Board of Trade, desires to hear from all the creditors of Tabor Bros., of Dallas, Tex. The firm have offered to compromise with their creditors on a basis of 30 per cent., to be paid in cash, on presentation of the compromise papers bearing all the creditors' names.

The storm of several weeks ago seriously interfered with the time service of the Western Union Telegraph Co., and many jewelers in various parts of the country were deprived of the standard time by the entanglement and falling of the wires. Last Saturday Manager James Hamblet, who controls the time service of the United States, informed a CIRCULAR reporter that the system would be in perfect working order in a few days.

WE ♦ WISH ♦ TO ♦ SUGGEST

That this is about **T**he right Season
 for those of the trade w **H**o have not yet purchased
 from us any of th **E** well-known cuff-
 buttons called the **A**nti-Swear, of which
 we are the o **N**ly manufacturers,
 and that are sold solely **T**o the Retail Jewelry Trade
 thereby preventing ru **I**nous competition from
 the Dry Goods, al **S**o other outside trades.
We
 wish to call sp **E**cial attention here
 to the action of the **A**nti-Swear button, which
 is automatic in its wo **R**king, and which we believe
 we can recommend as

THE SIMPLEST, THE MOST DURABLE, THE MOST SALABLE
 BUTTON FASTENING EVER MADE.



Examine them, try them, and satisfy yourselves.

SEND FOR A SELECTION TO

J. T. SCOTT & CO.,
 4 MAIDEN LANE, NEW YORK.

The regular quarterly meeting of the New York Jewelers' Association will take place this afternoon.

M. A. Sawyer, formerly of Providence, is now representing Bippert & Co., of Newark, N. J., in this city and Brooklyn.

Surrogate Ransom last week signed a memorandum for the counsel in the estates of the late W. F. Ladd, of Wall st.

Among the directors of the new Crockery Board of Trade which was incorporated last Thursday, is Isador Straus of L. Straus & Sons, 42-43 Warren st.

The watch case manufacturers of this city are looking forward with considerable interest to the "public agitation meeting" to be held in Brooklyn on March 28 by the Watch-case Makers' Union.

The action of J. T. Scott & Co. against Adolph Alexander has been taken from the calendar of the Supreme Court. The suit was for a balance of \$50.00 on goods sold the defendant. The matter was settled without coming to a trial.

The suit of A. Witnauer against Jens Pederesen for the recovery of \$700, being the balance on an account for goods sold, when called in the Supreme Court last week, was announced to have been settled. The terms of the settlement have not been made public.

The New York trade have received notification that the firm of Patek, Philippe & Co., of Geneva, Switzerland, has expired by limitation, and that E. Koehn, who was a member of the firm for thirty years, has decided to set up in business for himself. H. R. Ekegren, well-known to the importing trade, will be his manager.

In Part III. of the Supreme Court last Thursday, Judge Andrews awarded a judgment for \$500 in favor of H. Henrich against Viemeister Bros., of Brooklyn. Lawyer C. F. Holmes appeared for the defendants and desired the case adjourned for one week. This was refused, and there being substantially no defence, a judgment was accordingly ordered.

The New York creditors of Sumner Bros., Cleveland O., through Attorney Peter Zuecker of that city have applied to the Probate Court for the removal of the present assignee. The creditors opposed to the assignee represent over \$60,000. The New York Jewelers' Board of Trade and the New York Jewelers' Association are both using every effort possible for the appointment of a trustee.

Judge Beach, of the Supreme Court, has granted an order to show cause why an injunction should not be issued in an action brought by Silas M. Stilwell against the American Soda Fountain Co., James W. Tufts and others, restraining them from buying the business and property of the other defendants. Mr. Tufts is a manufacturer of silver-plated ware at 33 Bowker st., Boston, Mass.

Ferd. L. Cahn, a traveler for I. Michelson & Co., 3 Maiden Lane, has written to his firm complaining of the annoyance caused him by the similarity of his name with that of Ferdinand W. Cahn, the thieving clerk of

Henry E. Oppenheimer & Co. Several jewelers in various parts of the country who read the account of the thefts in THE CIRCULAR confused the names, and in consequence caused the traveling salesmen much trouble. To add to the complication Cahn, the alleged thief was at one time employed as a clerk with Traitel Bros., the members of which firm are cousins of I. Michelson & Co.'s traveler.

The examination of Charles A. Bailey, John Tiedman and H. D. Klinker, of the Chicago Watch and Jewelry Co., who were

arrested at the instance of Anthony Comstock for violating the lottery laws, was adjourned last Saturday in the Tombs Police Court for one week. Manager Klinker waived examination to go before the Grand Jury. Mr. Comstock told a CIRCULAR reporter that he had no doubt but that the other defendants would do the same at the next hearing of the case. The charge against the men for unlawfully using the mails will come up before Commissioner John A. Shields, in the United States Circuit Court this afternoon.

KREMENTZ & Co.,

182 & 184 Broadway, NEW YORK,

MANUFACTURERS OF

GOLD JEWELRY,

14-K. BEAD NECKLACES,

— AND —

KREMENTZ ONE-PIECE COLLAR BUTTONS.

DORFLINGER'S AMERICAN CUT GLASS.

The Finest Crystal, Plain and Cut, made in the World.



EVERYTHING that is used in Glass, for the Table.

Sells as well as Silver-ware.

EVERY FIRST-CLASS JEWELER

C. DORFLINGER & SONS,



BEAUTIFUL, Artistic and Useful Pieces for Gifts.

Rivals the Diamond for Purity and Lustre.

SHOULD KEEP IT.

36 Murray Street, New York.



Fleur de Lis "VICTORIAS."

WE ARE SHOWING THE

Most Popular Line

IN THE MARKET.

H. F. BARROWS & Co.,

1½A Maiden Lane, N. Y

CLASSIFIED INDEX TO ADVERTISEMENTS.

All Advertisements are entitled to one insertion under proper heading. Extra insertions, \$6.00 per Annum. Extra Headings \$12.00 per Annum.

	PAGE.		PAGE.		PAGE.
Assayers & Refiners.		Gold Jewelry.		Silver Plated Ware.	
Baker & Co., Newark, N. J.....	20	Carter, Sloan & Co., 15 Maiden Lane, N. Y....	8	Pairpoint Mfg. Co., New Bedford, Mass.....	5
Howard, S. P., 8 John st., N. Y.....	48	Cottle, S. Co., 860 Broadway, N. Y.....	40	Rogers & Hamilton Co. The, Waterbury, Conn.	48
Lelong, L., & Bro., Newark, N. J.....	48	Kremetz & Co., 182 Broadway N. Y.....	27	Rogers & Bro., 16 Cortlandt st., N. Y.....	13
Platt, Chas. S., 31 Gold st., N. Y.....	48	Larter, Elcox & Co., 41 Maiden Lane, N. Y....	9	Rogers, Wm., Mfg. Co., Hartford, Conn.....	46
Robertson & Leber, 13 Franklin st., Newark, N. J.....	42	Moore & Horton, 11 Maiden Lane, N. Y.....	10		
		Riley, J. A., & Sloan Co., 860 Broadway, N. Y.	16	Stem-Winding Attachments.	
		Snow & Westcott, 3 Maiden Lane, N. Y.....	12, 42	Abbott, Henry, 4 Maiden Lane, N. Y.....	36
		Street, Geo. O. & Sons, 15 John st., N. Y.....	7		
Auctioneers.		Gold Chains.		Sterling Silver Novelties.	
Comrie, A. J., 16 West 125th st., N. Y.....	33	Rickert & Stiehle, Newark, N. J.....	19	Alvin Mfg. Co., 860 Broadway N. Y.....	10
French, J. H., Box 2775, N. Y.....	35			La Pierre, F. H., 18 East 14th st., N. Y.....	9
		Horological Schools.		Lewis Bros., 41 Maiden Lane, N. Y.....	7
Badges, Medals, etc.		Elgin Horological School, Elgin, Ill.....	37	Sterling Silverware.	
Stockwell, E. R. 13 John st., N. Y.....	34	Waltham School of Horology, Waltham, Mass.	42	Durgin, W. B., Concord, N. H.....	45
				Gorham Mfg. Co., 19th st. & Broadway N. Y..	24
Black Onyx Jewelry.		Jewelry Repairers.		Towle Mfg. Co., Newburyport, Mass.....	35
Woglom, Gilbert T., 32 John st., N. Y.....	38	Wiederhold, A., 20 Maiden Lane, N. Y.....	10	Wallace, R. & Sons, Mfg. Co., 3 Park Place, N. Y.....	6
				Wood & Hughes, 16 John st., N. Y.....	23
Books, Stationery, etc.		Jobbers, Watches, Diamonds, etc.		Thimbles.	
Chicago Envelope Clasp Co., Chicago, Ill.....	7	Aikin, Lambert & Co., 23 Maiden Lane, N. Y.	40	Ketcham & McDougall, 198 Broadway, N. Y...	21
Dickie, W. B., 67 William st., N. Y.....	34	Beguelin, Tell A., 71 Nassau st., N. Y.....	15		
		Bowman & Musser, Lancaster, Pa.....	17	Tool Manufacturers and Dealers.	
Cut Glass.		Conover, D. F. & Co., Philadelphia, Pa.....	5	American Watch Tool Co., Waltham, Mass....	41
Clark, T. B. & Co., 53 Park Place, N. Y.....	38	Cross & Beguelin, 21 Maiden Lane, N. Y.....	12	Bullock, O. W. & Co., Springfield, Mass.....	4
Dorflinger, C. & Sons, 36 Murray st., N. Y.....	27	Friedlander, R. & L., 65 Nassau st., N. Y.....	15, 23	Nordman Bros., San Francisco, Cal...	42
Mt. Washington Glass Co., New Bedford, Mass.	40	Koch & Dreyfus, 22 John st., N. Y.....	23		
		Myers, S. F. & Co., 48 Maiden Lane, N. Y.....	48	Watch Collections.	
Diamond & Precious Stone Importers.		Scott, J. T. & Co., 4 Maiden Lane, N. Y.....	26	Marfels, Carl, Frankfurt on-the-Main, Ger- many.....	47
Fera, Henry, 10 Maiden Lane, N. Y.....	40	Yates, John B., 147 Nassau st., N. Y.....	21		
Hedges Wm. S. & Co., 170 Broadway, N. Y....	39			Watch Companies.	
Kahn, L. & M. & Co., 10 Maiden Lane, N. Y.	48	Musical Boxes.		Non-Magnetic Watch Co., 177 Broadway, N. Y.	33
Kipling, E. E., 2 John st., N. Y.....	48	Jacot & Son, 298 Broadway, New York.....	38	Stop! Start!.....	42
Kipling, R. A. 31 Union Square, N. Y.....	39			Trenton Watch Co., Trenton, N. J.....	11
Lorsch, Albert & Co., 37 Maiden Lane, N. Y...	48	Optical Goods.			
Oppenheimer Bros., & Veith, 35 Maiden Lane, N. Y.....	16	Geneva Optical Co., 23 Washington st., Chicago, Ill.....	-15, 39, 46	Watch & Clock Dials.	
Pinover, A. & Co., 25 Ann st., N. Y.....	38			Waltham Dial Co., Waltham, Mass.....	19
Randei, Baremore & Billings, 29 Maiden Lane, N. Y.....	0	Order Work.			
Smith, Alfred H. & Co., 182 Broadway, N. Y....	24	Maxheimer & Beresford, 3 Maiden Lane, N. Y.	39	Watch & Clock Oils	
Taylor & Bro., 860 Broadway, N. Y.....	40			Ginnel, Henry & Co., 31 Maiden Lane, N. Y...	7
Wheeler, Hayden W. & Co., 2 Maiden Lane, N. Y.....	19	Pens, Pencil Cases, Etc.		Nye, William F., New Bedford, Mass.....	46
		Aikin, Lambert & Co., 23 Maiden Lane, N. Y.	40		
Diamond Cutters.		Ring Makers.		Watch Keys.	
Groenman, A. J. & Co., 80 Nassau st., N. Y....	4	Bryant, M. B. & Co., 10 Maiden Lane, N. Y., 16	21	Clark, A. N., Plainville, Conn.....	39
		Haskell, H. C., 192 Broadway, N. Y.....	21	Kendrick & Davis, Lebanon, N. H.....	10
Diamond Jewelry.		Hildreth Mfg. Co., 51 Maiden Lane, N. Y.....	10		
Bynner, T. B., 177 Broadway, N. Y.....	29	Odenheimer & Zimmern, 46 Maiden Lane, N. Y.	48	Watch Case Manufacturers.	
Falkenau, Oppenheimer & Co., 40 Maiden Lane, N. Y.....	48	Ostby & Barton, 80 Clifford st., Providence, R. I.....	34	Courvoisier, Wilcox Mfg. Co., 41 Maiden Lane, N. Y.....	14
Ludwig, Nissen, & Co., 18 John st., N. Y.....	10			Essex Watch Case Co., Newark, N. J.....	33
Stern Bros., 42 Maiden Lane, N. Y.....	39	Rolled Plate Chains.		Muhr's Sons, H., 629 Chestnut st., Philadelphia, Pa.....	48
Sexton Bros. & Washburn, 41 Maiden Lane, N. Y.....	39	Barrows, H. F. & Co., 1½ A, Maiden Lane, N. Y.....	27	Roy Watch Case Co., 17 Maiden Lane, N. Y.	48
		Kent & Stanley, 7 Eddy st., Providence, R. I....	3		
Engravers and Designers.		Rolled Plate Jewelry.		Watch Case Repairers.	
Bartholomew & Peckham, 18 Spruce st., N. Y.	34	Crossin & Tucker, 409 Pine st., Providence, R. I.....	23	Feinier, G. F., 9 Bond st., N. Y.....	36
Ryder & Dearth, 146 Westminster st., Provi- dence, R. I.....	38	Foster & Bailey, 60 Richmond st., Providence. R. I.....	37		
		Ludwig, H. & Co., Providence, R. I.	38	Watch Importers.	
Eye Glass Holders & Chains.		Plainville Stock Co., Plainville, Mass.	15	Didisheim, Hipp, 83 Nassau st., N. Y.....	46
Merritt, S. F., Springfield, Mass.....	4			Hydes' Sons, John E., 22 Maiden Lane, N. Y...	15
		Seamless Wire.		Joharson, Olof, 192 Broadway, N. Y.	29
Fine Jewelry.		Burdon Seamless Filled Wire Co., Providence, R. I.....	15	Wittnauer, A., 30 Maiden Lane, N. Y.....	37
Day & Clark, 10 Maiden Lane, N. Y.....	40			Watch Materials, &c.	
		Settings & Galleries.		Cross & Beguelin, 21 Maiden Lane, N. Y.....	12
Gas Engines.		Blancard & Co., 36 John st., N. Y.....	15	Friedlander, R. & L., 65 Nassau st., N. Y....	15, 23
Schleicher, Schumm & Co., Philadelphia, Pa...	42			Keller, L. H. & Co., 64 Nassau st., N. Y.....	7
		Silk Guards.		Washburn & Moen Mfg. Co., Worcester, Mass.	29
Gold and Silver Platers.		Rosentall, Wm., 79 Nassau st., N. Y.....	37		
Newman, Louis, Jr., 36 John st., N. Y.....	48			Watch Repairers.	
				Juzek, Thos. & Co., Elgin, Ill.....	39
				Simmonds, J. C., 18 John st., N. Y.....	19

Special Notices.

Rates 75c. per insertion for notices, not exceeding 3 lines; additional words 2 cents each. If answers are to be forwarded, postage stamps must be enclosed. Two insertions, 10 per cent. off; three insertions, 15 per cent. off; four insertions, 25 per cent. off. Payable strictly in advance.

Situations Wanted.

THE JEWELERS' CIRCULAR has a guaranteed circulation of over 10,000 copies weekly. It is, therefore, the best medium for reaching the trade. To demonstrate this to advertisers, notices in this column will be inserted free of charge during the month of March.

A JEWELER, first-class repairer and jobber, also fine engraver, wants a steady position; 11 years' experience; English, German and Scandinavian languages spoken; best references from former employers. Address, Jeweler, 45, JEWELERS' CIRCULAR.

A LIVE young man of ability and experience desires position with responsible house to represent them on the road; jewelry or watches preferred; familiar with southern trade; A 1 references. Address, Salesman, care of JEWELERS' CIRCULAR.

A NICKEL PLATER desires a situation; thoroughly understands the business; can give best of reference if required. Address, Plater B, this office.

A YOUNG MAN, aged 21, who has worked at the watchmaker's bench about two years, wants to finish the trade with a good workman; good reference; good habits. Address, N. R. H., 232 West 5th street, Hutchinson, Kansas.

COMPETENT book-keeper, disengaged after 3 p. m., would like employment; terms moderate. Address, H. P., care of JEWELERS' CIRCULAR.

FIRST CLASS watchmaker with twenty years' experience, wants a position in New England States; can give first-class references; German descent, four years in U. S. Address, A. L., care of E. F. Rohn, 304 Chestnut street, Milwaukee, Wis.

SALESMAN wishes position in first class manufacturing house. Good trade in City, Brooklyn, N. Y. State, Phila., Balt., and Washington. Address Hustler, JEWELERS' CIRCULAR.

WANTED.—By a single man, 26 years of age, a position in a wholesale jewelry or diamond importing house, as salesman in office or to travel. Have had five years' experience in a retail jewelry store. Highest references given. Address, V. Z., care of JEWELERS' CIRCULAR.

T. B. BYNNER,

Dealer in

Diamonds, Opals, Pearls,

AND EVERY VARIETY OF PRECIOUS STONES,

in varied and novel combinations.

177 BROADWAY, NEW YORK.

OLOF JOHANSON,

Dealer in Fine

Imported and American Watches,

And Diamonds, Jewelry, Etc.

192 BROADWAY,

Room 37. NEW YORK.

Repairing and Adjusting Fine Watches. The only party who has all kinds of Materials for the Marion Watches.

BAKER & CO.,

Gold, Silver and Platinum Refiners,

ASSAYERS * AND * SWEEP * SMELTERS,

408 New Jersey Railroad Avenue,

Cor. Murray Street, NEWARK, N. J.

WANTED by a young man of 21, a position in a wholesale jewelry, diamond or clock house, as salesman; have 6 years' experience in a retail jewelry store; best of references given. Address, H. C. MacEwen, Jr., 522 Tremont St., Boston, Mass.

WANTED.—Position by a first class watchmaker, clockmaker, jeweler, and repairer of musical toys, etc. Can put my hands to any variety of repairing work. Have had thirty years' experience; can furnish best of references and security if desired. Would prefer a position in New York City or near-by town. Address, D. H. J., care THE JEWELERS' CIRCULAR.

WANTED.—Situation by a watchmaker of 15 years, experience; full set of tools and best references furnished; North or West preferred. Address, C. A. S. Edgett, 45 East Mitchell street, Atlanta, Ga.

WATCHMAKER with 19 years' experience, would like a situation. Salary, \$18 per week. Can do all kinds of watch work and engrave; have all tools. Address, Conrad Kohler, Alexander, La.

YOUNG MAN with six years' experience, who understands watch and clock work, when not complicated, would like a position with a first-class watchmaker, to finish learning the trade. Is temperate, honest and industrious, and has all necessary tools except American lathe. Best reference; moderate salary expected at first. Address Jas. H. Grubb, Clearville, Pa.

Help Wanted

A FIRST CLASS watchmaker wanted; wages, \$20 per week. Send photograph and sample of work to P. H. Lachicotte & Co., Columbia, S. C.

WANTED.—A few traveling men who are practical watchmakers, and have the time—to call the attention of the craft to the Mosely Lathe and Attachments, through the East and Southwest. Address, Mosely & Co., Elgin, Ill.

WANTED.—A first-class jewelry salesman; one thoroughly posted in diamonds. Address, with reference, Wright, Kay & Co., Detroit, Mich.

WANTED.—A first class traveler. One acquainted with Texas trade preferred; good salary. Address, Koch & Dreyfus, 22 John street, New York.

WANTED.—Man who can do hard solder work, clock repairing, help out on watch work and wait on customers; must be honest and of good habits; salary to start with, \$10 to \$12 per week. Address, L., care H. T. Spear & Son, 370 Washington st., Boston, Mass.

WANTED.—One or two first-class jewelers; must be able to execute the finest grade of Pearl, and other stone settings. Address, with reference, Wright Kay & Co., Detroit, Mich.

WASHBURN & MOEN MFG. CO., WORCESTER, MASS.

Every Variety of Wire for all Purposes.

Manufacturers of FINE WATCH MAINSPRINGS for American, Swiss and English Watches, which for Toughness, Elasticity and Finish, are Unequaled.

Eye-Glass Springs, Clock Springs

N. Y. WAREHOUSE: CHICAGO WAREHOUSE:
16 Cliff Street. 107 to 109 Lake St.

Roundabout Notes.

The stock of J. H. Laidlow, Sarnia, Ont., is advertised for sale.

Mr. Heckman, of Gillette & Heckman, Deadwood, S. D., is dead.

R. Warshowski, Altoona, Pa., has confessed judgment for \$1,400.

A chattel mortgage for \$2,500 has been given by J. F. Sargent, of Mount Pleasant, Iowa.

The product of the United States Watch factory averaged 118 watches per day during

For Sale.

A FINE ship chronometer for sale cheap. Address: A. C. Taylor, Cedar Rapids, Iowa.

FOR SALE.—One twelve-foot, two-dial street clock; in use only fifteen months; value \$165. Will sell for \$75. In settling estate fell to disinterested party. Address "Heir," care of CIRCULAR.

FOR SALE or exchange for goods, a large Herring or Terwilliger jewelry safe. Address, T. B. Bynner, 177 Broadway, N. Y.

To Let.

TO LET.—First floor back, No. 18 John street, 3 windows; possession at once if desired. Apply to Chas. Magnus.

TO MANUFACTURING JEWELERS AND OTHERS.—A floor to let in the new improved factory building, corner St. Marks and Underhill avenues, Brooklyn. Fine light, power and all modern improvements; within twenty minutes of the Brooklyn ferries. Apply to Geo. W. Shiebler, 8 Liberty Place, New York City.

Business Opportunities.

\$2,000 IN CASH and two thousand in notes, will buy old-established and paying jewelry business near New York. Address, Wm. McAdie, with Rogers & Bro., 16 Cortlandt St., N. Y.

\$4,000 IN CASH will buy out a business in best jewelry city in America, of 300,000; opening seldom offered. For particulars, write C. B., care of THE JEWELERS' CIRCULAR.

JEWELRY and music store in a growing town in eastern Penn., can reduce stock to \$1,500; light opposition; low rent; must sell on account of poor health. Address, G. W., care of JEWELERS' CIRCULAR.

Miscellaneous.

W. A. SCHROETER, 198 Grand street, New York City. Estimates rendered on any desired job. Four expert watch repairers employed specially for Trade Work. Guaranteed finely finished at low prices. Also a good chance for a young man to study watchmaking.

W. F. A. WOODCOCK'S SCHOOL FOR WATCHMAKERS, Winona, Minn., offers unrivaled facilities for acquiring a thorough practical knowledge of every branch of the business. Terms very reasonable.

the month of February, and the force at work in the factory is the largest in history. The projected addition to their building will be made some time this spring.

The Pacific Coast.

L. Luth, Oakland, Cal., has sold out to Peter Johnson.

Charles Daunt, Modesta, Cal., has moved into his new quarters on 10th st.

N. M. Bailey, Rio Vista, Cal., has been on a prospecting tour in the mountains.

Charles Eisenbeis, Port Townsend, Wash., is making a special sale of diamonds and watches.

C. W. Richardson has succeeded to the business of Richardson & Stiver at Woodlands, Cal., and has enlarged his store and stock.

A. Muirhead, a practical watch-maker and jeweler of twenty-five years' experience in the East, has opened a store at Auburn, Cal.

D. E. LaRue, of Riverside, Cal., has sold his business to Conrad Brothers. W. K. Conrad had been in the employ of Mr. LaRue for some time, and is a skilled workman.

VALUABLE INSTRUCTION BOOKS

FOR SALE BY

THE JEWELERS' CIRCULAR PUBLISHING CO., 189 Broadway, N. Y.

Goldsmiths' Handbook , containing full instructions for the Alloying and Working of Gold. By GEO. E. GEE. Price, post-paid,	\$1 25	Prize Essay on the Balance Spring and its Technical Adjustments (Baroness Burdette Coutts' Prize). By M. IMATSI. Cuts, crown, 8vo, cloth,	1 00
Silversmiths' Handbook , containing full instructions for the Alloying and Working of Silver. By GEO. E. GEE. Price, post-paid,	1 25	A Handbook of Precious Stones . By M. D. ROTHSCHILD. Cloth. Illustrated,	1 00
Practical Instruction in the Art of Letter Engraving . By G. F. WHELPLEY. Price, post-paid,	2 00	Electrolysis ; a Practical Treatise on Nickeling, Coppering, Gilding, Silvering and Reining of Metals and Treatment of Ores by Means of Electricity. By H. FONTAINE. With 34 Illustrations,	3 50
Kemlo's Watch Repairer's Handbook . Illustrated. For beginners and advanced workmen. By F. KEMLO. Price, post-paid,	1 25	Electro-Plating . A Practical Handbook on the deposition of Copper, Silver, Nickel, Gold, Aluminum, Brass, Platinum, etc.; with descriptions of the Chemicals, Materials, Batteries and Dynamo Machines used in the Art. By J. W. URQUHART,	2 00
Watch and Clock Making (with 63 diagrams). By DAVID GLASGOW, President of the British Horological Institute. Price, post-paid,	2 00	Electro-Deposition ; a Practical Treatise on the Electrolysis of Gold, Silver, Copper, Nickel and other Metals and Alloys, with Descriptions of Voltaic Batteries; Magnets and Dynamo-Electric Machines; Thermopiles, and of the Material and Processes used in every Department of the Art and Several Chapters on Electro-Metallurgy. By A. WATT.	3 50
Treatise on Watch Work, Past and Present . By the Rev. H. D. NELTHROP, M. A., F. S. A. Numerous Illustrations. Crown, 8vo, cloth. Price, post-paid,	2 50	The Metallic Alloys . A Practical Guide for the Manufacture of all kinds of Alloys, Amalgams and Solders used by Metal Workers, together with their Chemical and Physical Properties and their Application in the Arts and the Industries; with an Appendix on the Coloring of Alloys. From the German of A. Krupp and Andreas Wildberger. Illustrated by 16 Engravings.	2 50
Treatise on Modern Horology in Theory and Practice . By M. CLAUDIUS SAUSNER. Translated by JULIEN TRIPPLIN, Besancon Watch Manufacturer, and EDWARD RIGG, M. A., Assayer in the Royal Mint, London. Price,	15 00	A Treatise on the Transit Instrument as Applied to the Determination of Time . By LATIMER CLARK, M. I. C. E.	2 00
<i>This valuable work comprises 822 large octavo pages, with 78 Wood Cut; and 21 colored double-page, copper-plate Engravings, is printed on excellent paper and bound in half calf, with a handsome and appropriate ornament in gold on front cover.</i>		Manual of the Transit Instrument , as used for obtaining Correct Time. By LATIMER CLARK, M. I. C. E.	40
Watch and Clockmaker's Handbook, Dictionary and Guide . 1889 Edition. Revised. By F. J. BRITTEN. Price, post-paid,	2 00	Turning Lathes . A Manual for Technical Schools and Apprentices. A Guide to Turning, Screw Cutting, Metal Spinning, etc. 194 Illustrations. Edited by JAMES LUKIN, B. A.	1 00
Watchmaker's Handbook . Latest edition, revised and enlarged. Same Author and Translator, and intended as a Companion to the Treatise. Illustrated by 14 double-page Copper-plate Engravings and numerous Wood Cuts; cloth cover. Price, post-paid,	3 50	Workshop Receipts for the use of Manufacturers, Mechanics and Scientific Amateurs. By ERNEST SPON.	2 00
Handbook for Opticians . By W. BOHNE. Illustrated. Price,	2 50	Gems and Precious Stones of North America . By GEO. F. KUNZ. A popular description of their occurrence, value, history, archæology, and of the collections in which they exist; also a chapter on Pearls. Illustrated with 8 colored plates and numerous minor engravings.	10 00
Detection and Correction of Visual Imperfections . (With Test Type.) By Dr. C. A. BUCKLIN, A. M., M. D. Price, post-paid,	1 00		
The Watch Jobber's Handy Book . A Practical Manual on Cleaning, Repairing and Adjusting Watches; with Information on the Tools, Materials, Appliances and Processes employed in Watchwork. By PAUL N. HASLUCK. 100 Illustrations,	0 80		
The Clock Jobber's Handy Book . A Practical Manual on Cleaning, Repairing and Adjusting Clocks; with Information on the Tools, Materials, Appliances and Processes used in Clockwork. By PAUL N. HASLUCK. 100 Illustrations,	0 80		

ALL PRICES PAYABLE IN ADVANCE.

As a special inducement to new subscribers, we make the following offer :

Add One dollar to the price of any book in this list, and we will send it with THE JEWELERS' CIRCULAR for One Year. The regular price of THE CIRCULAR is Two dollars.

OR

We will send The Circular for six months on trial for Fifty Cents.

OR

For Two dollars, we will send it for One Year and a copy of any of these three books free :

DICKIES' IMPROVED WATCH REPAIR BOOK, containing 100 pages, ruled for full record of all repairing handled.

DICKIES' IMPROVED WATCH STOCK BOOK, same as above, but ruled for purchase and sales of Watches.

DIETZ' BOOK OF MONOGRAMS, containing over 3,000 monograms for the engravers' use. This book is indexed, so you can find any combination in ten seconds' time.

OUR CLUBBING LIST.

In order to have our readers secure their other publications at as cheap a rate as possible, we offer the following clubbing rates to those who order them through us.

	Regular Price.	With the JEWELERS' CIRCULAR.		Regular Price.	With the JEWELERS' CIRCULAR.
Century Magazine,	\$4.00	\$4.50	Harper's Young People,	2.00	2.50
St. Nicholas,	3.00	3.50	Harper's Magazine,	4.00	4.00
New York Ledger,	2.00	2.50	Frank Leslie's Illustrated Weekly,	4.00	4.25
Harper's Weekly,	4.00	4.25	Judge,	5.00	5.00
Harper's Bazaar,	4.00	4.25			

PREMIUM LIST.

TO THE RETAIL TRADE:

We want 10,000 new subscribers added to our subscription list, and in order to get them we make some remarkable inducements for a LIMITED TIME ONLY.

SEND US TWO DOLLARS,

The regular subscription price of THE CIRCULAR, and we will send you any of the combinations described below, and

THE JEWELERS' CIRCULAR FOR ONE YEAR.

The articles in any of these combinations if purchased separately would cost from \$2.00 to \$3.00. They have been carefully arranged by an expert watchmaker as being such as are called for in every days' experience. They are first-class goods, will be carefully selected, and sent promptly.

In ordering, be particular to do so by the letter as arranged.

COMBINATION A.

Two dozen American Cock and Foot Jewels, assorted as follows:

1/4 doz.	Waltham,	18s.,	O. M.,	Cock.
1/4 "	"	18s.,	"	Foot.
1/4 "	"	18s.,	N. M.,	Cock.
1/4 "	"	18s.,	"	Foot.
1/4 "	Elgin,	18s.,	"	Cock.
1/4 "	"	18s.,	"	Foot.
1/4 "	Illinois,	18s.,	"	C. & F.
1/4 "	Hampden,	18s.,	"	C. & F.

COMBINATION B.

Two dozen American assorted Cock and Foot Jewels.

1/3 doz.	assorted Waltham,	18s.	C. & F.
1/3 "	"	Elgin,	18s.,
1/3 "	"	Illinois,	18s.,
1/3 "	"	Hampden,	18s.,
1/3 "	"	Rockford,	18s.,
1/3 "	"	Columbus,	18s.,
1/3 "	"	Peoria,	18s.,
1/3 "	"	Seth Thomas,	18s.,
1/3 "	"	Trenton,	18s.,
1/3 "	"	Lancaster,	18s.,

COMBINATION C.

Two dozen American Endstones, assorted.
Same as Combination A.

COMBINATION E.

Two Doz. American Balance Staffs assorted as follows:

1/3 doz.	Waltham,	18s.	assorted styles.
1/3 "	Elgin,	18s.	" grades.
1/3 "	Illinois,	18s.	" "
1/3 "	Rockford,	18s.	" "
1/3 "	Hampden,	18s.	" "
1/6 "	Columbus,	18s.	" "
1/6 "	Seth Thomas,	18s.	" "

COMBINATION G.

Two Doz. American Windings and Interwinding Wheels, assorted as follows:

1/3 doz.	Waltham,	18s.
1/6 "	"	18s.
1/3 "	Elgin,	18s.
1/6 "	"	6 & 8s.
1/3 "	Rockford,	18s.
1/3 "	Hampden,	18s.
1/3 "	Illinois,	18s.

COMBINATION I.

Four dozen assorted Yoke, Clutch and Click springs for American Watches. Only such will be sent for which you will find steady demand.

COMBINATION L.

One gross assorted American Hands assorted as follows:

1 doz	18s. Spade, K. W.
1 "	18s. " S. W.
1 "	8s. " S. W.
1 "	8s. Morning Glory, S. W.
1 "	1s. Spade, S. W.
1 "	18s. Moon, K. W.
1 "	18s. " S. W.
1 "	18s. Morning Glory, K. W.
1 "	" " S. W.
1 "	18s. Seconds.
1 "	8s. "
1 "	1s. "

COMBINATION N.

Five dozen assorted Clark's (4 screw) steel lift and catch case springs suitable for Swiss and American cases.

COMBINATION D.

Two dozen American Endstones, assorted.
Same as Combination B.

COMBINATION F.

Eight dozen American Roller Jewels assorted as follows:

1 doz.	Waltham,	18s.
1 "	"	8s.
1 "	Elgin,	18s.
1 "	"	6 & 8s.
1 "	Rockford,	18s.
1 "	Illinois,	18s.
1 "	"	4s.
1 "	Hampden,	18s.

COMBINATION H.

Two dozen assorted Yoke, Clutch and Click springs for Swiss Watches, the most desirable patterns and only those for which there is a constant demand.

COMBINATION K.

Six doz. assorted American Collected Hair Springs assorted as follows:

1 doz.	Waltham,	18s.
1 "	"	8s.
1 "	"	1s.
1 "	Elgin,	18s.
1 "	"	16s.
1 "	"	6 and 8s.

COMBINATION M.

Two doz. *Harstroms* Pat. Casesprings, assorted sizes (considered to be the best and most easily fitted spring in the market.)

COMBINATION O.

Jewelry Findings assorted as follows:

1 doz.	Plated Clipped Catches.
1 "	" Joints.
1 "	Roll Plated Ear Wires.
3 "	Burnished Pintongs.
1/3 "	R. P. Lever Button Backs.
1/2 "	" " Spiral Stud "
1/3 "	" " Scarfpin "
1 "	" " Jump Rings assorted sizes.
1 "	Bracelet and Necklace Snap Catches.

COMBINATION P.

Two dozen fine American Mainsprings, assorted sizes, for Waltham and Elgin Watches.

TRADE GOSSIP

Dealers desiring jewelry repair work done should try Alex. Wiederhold, 20 Maiden Lane, New York.

Business with the Pairpoint Mfg. Co., New Bedford, Mass., has never been better than at the present time, and even thus early in the season the entire factory is running full time.

After May 1 all the business of James W. Miller, successor to Miller Bros. & Co., will be done from the factory 49 Franklin street, Newark, N. J., the office at 37 Union Square, New York being relinquished on that date.

T. B. Bynner, 177 Broadway New York, started last Monday on an extended business and pleasure trip through the South. He carries with him a large line of novelties and special styles in fine goods, both attractive and salable.

One of the hits of the season is the "Grape Jewelry" introduced this season by Crossin & Tucker, 409 Pine St., Providence. It is a very clever imitation of the berry of the grape and lends itself very prettily to the use of ornament.

Ostby & Barton's large force of employes are engaged on an extensive line of new samples in both band and fancy stone rings for the fall season. True to their traditions, this house promises some entirely new features for its patrons during the coming season.

At the Chicago College of Horology a large number of men are receiving theoretical and practical instruction in watch making and engraving. The institute has all the features of a manual training school. The faculty of the college consists of C. R. Hart, G. D. Parsons, Thomas H. Wicks, H. H. Martin, M. D. and Dr. Charles B. Reed.

Henry E. Oppenheimer & Co. have recently made many improvements in their office at 47 Maiden Lane, New York. The factory has been removed from the first floor to the second floor, where it covers a loft over 140 feet long. The first floor is now wholly given up to office purposes, and presents an exceedingly business-like appearance,

One of the largest watch case repairing establishments in New York is that of G. F. Feiner, at 9 Bond st. Mr. Feiner formerly had charge of the watch case repairing department of Robbins & Appleton, and is an expert in that branch of the trade. In his new establishment, besides having the latest improved machinery for manufacturing cases, he has surrounded himself with artisans of recognized ability.

No more popular novelty has issued from the Providence manufacturers this Spring than the "Washington" bracelet, designed

and made by Foster & Bailey. The demand for this historic souvenir increases every day, the well known "Stanley" bracelet, its forerunner, made by the same firm holding a pretty even race with it for favor. Every retailer ought to have these in stock, and can get them by applying to his jobber.

W. B. Durgin, the well known sterling silverware manufacturers of Concord, N. H., are deep in the souvenir spoon business. The quality of their spoon work is generally conceded to be unsurpassed, as also are their facilities for turning out such special order work as souvenir spoons. In their advertisement on another page they illustrate a popular orange spoon patented and manufactured by them, which is being infringed by certain other manufacturers, and they desire to caution the trade against handling the imitated article. Remember, W. B. Durgin are headquarters for souvenir spoons.

The Monarch mainsprings, for which R. & L. Friedlander, 65 Nassau st., New York, are the agents, are meeting with notable success among the watchmakers throughout the country. The firm receive a constant flow of unsolicited testimonials.

Albert Wiggers, of Wiggers & Froelick, 60 Nassau st., has invented a window tray for show windows that will undoubtedly attract much attention. It is arc-shaped, and when five of them are placed together they form a complete circle. The combinations and unique designs that can be formed with a half dozen of these trays are almost unlimited. The patent granted Mr. Wiggers is No. 447,221, and is described in the official record as follows:

"As a new article of manufacture, a tray composed of two side pieces formed of sections of cylinder-shells, having a common axis and diameters of different lengths, flat rectangular end pieces, and a flat bottom, substantially as described."

Suddenly Bethought Himself of Unpaid Fees.

About five years ago, John A. Wilson of Port Edward, N. Y., failed. F. A. Bratt, a local lawyer, attended to some of the legal matters on behalf of the New York creditors. A few months ago this lawyer bethought him that there was some fees still due him, and he began suit against Aikin, Lambert & Co., and J. T. Scott & Co., of New York, to recover from each the sum of \$200 alleged to be unpaid for services rendered in the shape of drawing papers and serving summonses.

Last Thursday the plaintiff presented his case before Referee L. H. Norfolk at Sandy Hill, N. Y. The defendants were represented by T. C. Smith, of Lawyer G. C. Comstock's office. The defendants stated in their answer that Mr. Bratt was never engaged by them and that, whatever work he accomplished on their behalf has long since been fully paid for.

J. A. Hardy, of Hardy & Hayes, Pittsburg, Pa., is in New York, looking up novelties for his house's Easter opening.

SEE OUR INDUCEMENTS TO NEW SUBSCRIBERS IN PAGES 30 AND 31.

Correspondence

The Use of Homatropine.

PHILADELPHIA, Pa., March 4, 1891.

To the Editor of *The Jewelers' Circular*:

Will you kindly insert in your journal something about the use of homatropine as a mydriatic, in what strength it should be used, in what cases it might prove harmful and whether it would be a safe drug for a careful optician to use with discretion. C. A. LONGSTRETH.

ANSWER.—A solution of hydrobromate of homatropine, two to eight grains to the fluid ounce of water—four grains to the fluid ounce is the average. It is dropped into the eye every two hours till the desired relaxation of accommodation is obtained. The effects pass off in twenty-four hours. It produces sufficient relaxation in moderate cases, but is not as effective as atropia. If used it should be ordered by a physician for the special purpose of fitting glasses, with full directions for its use. It will never be required by persons over forty-five years of age. No possible harm can result from its use excepting in those troubles which may arise on medico-legal grounds.

Opticians and the Medical Fraternity.

BRAINERD, Minn., March 3, 1891.

Dr. C. A. Bucklin:

I send you an advertisement of an eye water that a leading optical firm sends out, and would like to ask if it is not out of the province of an optician to deal in such things.

KNOWLEDGE.

As I am almost daily in receipt of similar enquiries I will answer them all by answering the above. A good business rule is "*Be honest with yourself.*" If this rule is followed intelligent and well posted opticians will not make the same business mistakes that this firm have made in placing an eye water before the public in connection with their optical trade. If the opticians whom I have instructed make this mistake they will very soon encounter the combined and organized opposition of the medical profession of their rural town. Opticians can do an optical trade without the assistance of the medical profession, but they cannot do a prosperous optical business with the combined and organized opposition of the medical profession. I am very anxious to have my students meet with the greatest possible success as opticians; consequently I unhesitatingly assure them that this new departure under consideration, will in time greatly endanger their best interests.

Back Numbers Wanted.

NEWARK, Ohio, Feb. 20, 1891.

To the Editor of *The Jewelers' Circular*:

If you know of any way to get for me or can put me in the way of getting Nos. 5, 8 and 12 of Vol. XIX. of THE CIRCULAR, I would be willing to pay whatever they cost.

E. F. SCHRACK.

We have not these numbers in the office. Can any one of our subscribers furnish them?

Recent Patents

Issue of March 3, 1891.

DESIGN No. **20,537**. SPOON, &C., FREDERICK H. SLOAN, Hartford, Conn.—Application filed January 22, 1891. Serial No. 378,703. Term of patent 3½ years.

DESIGN No. **20,541**. SPOON, &C. WILLIAM B. DURGIN, Concord, N. H.—Application filed January 21, 1891. Serial No. 378,599. Term of patent 7 years.

DESIGN No. **20,542**. HANDLE FOR SPOONS, &C. WILLIAM B. DURGIN, Concord, N. H.—Application filed January 29, 1891. Serial No. 379,579. Term of patent 7 years.

DESIGN No. **20,543**. HANDLE FOR SPOONS, &C. HENRY L. DOLE, Haverhill, Mass.—Application filed January 19, 1891. Serial No. 378,361. Term of patent 7 years.

DESIGN No. **20,545**. HANDLE FOR FORKS, SPOONS, OR SIMILAR WARE. CHARLES E. GALT, Philadelphia, Pa., assignor to Davis & Galt, same place.—Application filed January 7, 1891. Serial No. 377,044. Term of patent 7 years.

447,346. SEPARABLE BUTTON. EUGENE PRINGLE, Gloversville, N. Y., assignor to Madison D. Shipman and Charles E. Bradt, both of De Kalb, Ill.—Filed March 20, 1888. Serial No. 267,864. (No model.)

447,347. SEPARABLE BUTTON. EUGENE PRINGLE, Gloversville, N. Y., assignor to Madison D. Shipman and Charles E. Bradt, both of De Kalb, Ill.—Filed Sept. 8, 1888. Serial No. 284,942. (No model.)

447,348. SEPARABLE BUTTON. EUGENE PRINGLE, Gloversville, N. Y., assignor to Madison D. Shipman and Charles E. Bradt, both of De Kalb, Ill.—Filed Sept. 8, 1888. Serial No. 284,944. (No model.)

447,349. SEPARABLE BUTTON. EUGENE PRINGLE, Gloversville, N. Y., assignor to Madison D. Shipman and Charles E. Bradt, both of De Kalb, Ill.—Filed Sept. 8, 1888. Serial No. 284,947. (No model.)

447,409. ELECTRIC TIME-LOCK. JOSEPH H. KAISER and ANDREW B. LEDWITH, Brownsville, Pa.—Filed May 15, 1890. Serial No. 351,932. (No model.)

447,473. WATCH-CASE SPRING. JOSEF PALLWEBER, Furtwangen, Baden, assignor to Sigmund Stern, Frankfurt-on-the-Main, Germany.—Filed May 27, 1890. Serial No. 353,303. (No model.)

The combination of a watch-case with a pair of springs, a lever acted upon by both of the springs, a pin carried by the lever, and a lid engaged by the pin.

447,474. PENDANT-SET WATCH. ROSWELL L. PEABODY, New York, N. Y.—Filed Sept. 8, 1890. Serial No. 364,273. (No model.)

In a pendant winding and setting watch, the yoke carrying the winding and setting train and a partially rotating cam serving as an intermediate member, a lever for operating such cam to change the winding and setting mechanism from the hand-setting condition to the winding, as required, and having a bent arm engaged with the operating-collar on the stem.

447,692. BRACELET. ADOLPH W. MAGERHANS, New York, N. Y.—Filed June 28, 1890. Serial No. 357,142. (No model.)

In a bracelet, the combination, with a front link and a rear link of a tubular pivot extending loosely through an opening in the back plate of the front link, this tubular pivot being provided with an internal screw-thread to engage a screw and with two heads, one being situated between the front and rear plates of the front link while the other engages a cavity in the rear link.

ARE YOU DISSOLVING PARTNERSHIP
 ARE YOU HAVING DULL TRADE
 ARE YOU ABOUT TO RETIRE
 ARE YOU OVERSTOCKED
 ARE YOU REMOVING

IF YOU ARE, COMMUNICATE WITH

A. J. COMRIE,
 AUCTIONEER,

Specialty of Jewelers' Sales. 16 West 125th St., New York.

WE DESIRE to call your attention to our large and varied assortment of

Complicated, High Grade Gentlemen's and Ladies'



In Gold Cases, both Plain and Enameled, in Choice Designs.

THE LARGEST STOCK EVER SHOWN IN THIS COUNTRY.

NON-MAGNETIC WATCH CO.

OF AMERICA.

CHAS. MCCULLOH, RECEIVER

177 Broadway. - - NEW YORK.

Essex Watch Case

COMPANY,

T. B. HAGSTOZ, President.



TRADE MARK

GOLD FILLED CASES.

6 Maiden Lane, N. Y.

OFFICE,

NEWARK, N. J.

FACTORY,

BOOKS FOR JEWELERS.

W. B. DICKIE,

67 William Street, New York,
PUBLISHER OF

Improved Watch Stock Book

— AND —

Improved Watch Repair Book.

SEND FOR DESCRIPTIVE CIRCULAR.



E. R. STOCKWELL, MANUFACTURER OF BADGES AND MEDALS

IN GOLD
AND SILVER,



FOR ALL SOCIETIES,
INCLUDING

MASONIC
ODD FELLOWS,
GRAND ARMY.

Also for Schools.

BUTTON BADGES
IN SILVER OR GOLD.

Enameling and Repairing
for the trade.

19 John Street, N. Y.

ZIP!

Revolve these rings in your mind, and you cannot help thinking of OSTBY & BARTON, the well known ring makers, 80 Clifford St., Prov., R. I.

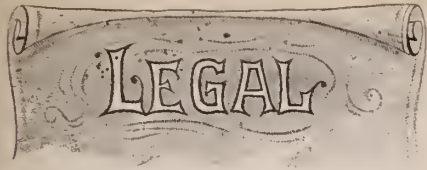

RELIANCE ON STATEMENT OF MERCANTILE AGENCY.

Where a merchant makes a statement of the condition of his affairs to a mercantile agency which is true at the time it was made, he is not bound to notify the agency of a change for the worse in his affairs short of absolute insolvency, and the fact that he does not will not support a charge of fraud in favor of those who sell him goods on the strength of his former statement after that statement had ceased to be true. A person selling goods to another upon the strength of mercantile agency report, is bound to take notice of the fact that the affairs of a business man are subject to changing conditions, and if he relies upon an old report, he must take his chances as to its correctness at the time he uses it.

RELEASE OF RAILROAD COMPANY FROM DAMAGE TO FREIGHT BY FIRE.

Where a bill of lading provides that the railroad company shall not be liable for any loss or damage to the goods shipped thereunder by fire, the company will still be liable for loss resulting from fire caused by negligence of its servants, and the burden of proof is on the company to show that the loss was within the exception, in addition to which it must be shown that the fire was one for which it was not responsible. In the absence of proof as to how the fire originated, the presumption is against the company.

RIGHTS OF PAYEE OF CHECK.

The drawer of a check had a deposit more than sufficient to pay it when drawn. Before presented the bank had assigned for the benefit of creditors, as had also the drawer of the check, and payment was refused. The holder could not recover judgment against the bank or its assignees, or the assignees of the drawer, but only against the drawer with an adjudication that the dividends paid by the assignees on account of the deposit be applied *pro rata* to the payment of the judgment.

LEGALITY OF CONTRACTS IN VIOLATION OF INTERSTATE COMMERCE ACT, MADE BEFORE ITS PASSAGE.

It is a rule of law that no contract can be properly carried into effect which was originally made contrary to the provisions of law, or which being made consistently with the rules of law at that time has become illegal in virtue of some subsequent law, and a contract entered into prior to the passage of the Interstate Commerce Law for the carriage of freight by a railway company at rates contrary to the provisions of that law cannot be enforced after its passage, and the shipper cannot recover any rebates stipulated for in such contract.

TOWLE MFG. CO.,

MANUFACTURERS OF



Sterling Silverware



NEWBURYPORT, MASS.: 214 MERRIMACK ST.

CHICAGO:
149 & 151 STATE ST.

SAN FRANCISCO:
220 SUTTER ST.

ESTABLISHED 1873.

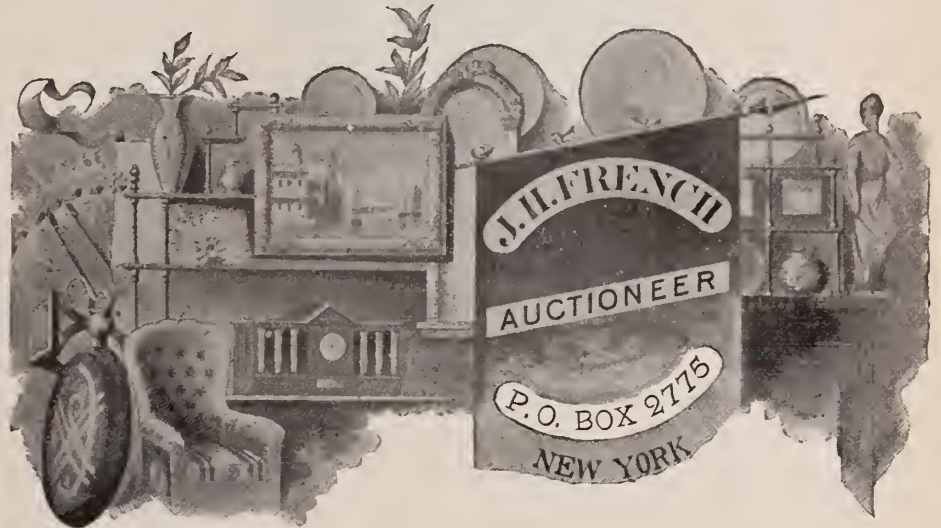

If for any reason you should desire the services of an AUCTIONEER, and will write me as to the amount of stock you have on hand and its general character, the size of your store and the number of inhabitants of your town or city, I could, from my extended experience, give you an idea of the amount of business you could expect under the circumstances, and, no doubt, be able to refer you to some one for whom I have sold under conditions similar to your own.

As a general reference, you could hardly find a wholesale jeweler who is not familiar with some of the numerous successful sales I have made.

I have made many successful AUCTION SALES, and have yet to record a failure to fully satisfy the owners. Can give you hundreds of references to that effect.

If the business should be urgent and I am myself engaged, I have two competent assistants instructed in my methods whom I could send on short notice.

Any correspondence with me will be strictly confidential in every case.
P. O. Box 2775.

NEW YORK CITY.

ONE OF THE OLDEST RESTAURANTS
DOWN TOWN.



POPULAR PRICES

WANTED, AN ADVERTISEMENT.

I will pay Fifty Dollars in cash to the Retail Jeweler who shall prepare the best worded and most effectively displayed advertisement of *Abbott's Patent Stem-Winding Attachment*, suitable for use in Magazines and Newspapers that reach the general public.

The advertisement to occupy a space of not more than two inches high by five inches wide.

The contest will close May 1st, 1891, and the prize will be awarded within ten days from that date

**I WILL PAY
FIFTY
DOLLARS
IN CASH**

The following gentlemen will act as judges:

Mr. L. J. MULFORD,
Of The Jewelers' Circular.

Mr. ALBERT ULMANN,
Of The Jewelers' Weekly.

Mr. JOHN L. SHEPHERD,
Of The Keystone.

Circulars and descriptive matter supplied on application.

HENRY ABBOTT,

After May 1st, 14 Maiden Lane.

4 Maiden Lane, N. Y.

WATCH * CASE * REPAIRING

WITH MY



IMPROVED MACHINERY and INCREASED FACILITIES,



I am enabled to do your work

BETTER,

QUICKER AND

CHEAPER.

IT IS TO

YOUR ADVANTAGE

TO GIVE ME A TRIAL.

G. F. FEINIER,

Manufacturer of Watch Cases; also Repairing of Every Description.

No. 9 Bond Street, New York.

Key-Wind Cases Altered to Stem Wind, and made same as New. English Cases Altered to take American Movements.

REFERENCE: ROBBINS & APPLETON, NEW YORK.

Theoretical and Practical Study of Depthing with Pinions of Low Number.

By J. Rambal, Watchmaker, etc., and Principal of the Horological School at Geneva, Switzerland.

(Continued from page 42, March 4.)

CONCLUSION.

WE now present the elements of gearing represented by Figures 7, 8, 9 and 10, also those of a gearing with a pinion of ten leaves, with measurements taken from large sized drawings:

Wheel.	Pinion.	Width of wheel tooth expressed in fractions of circular pitch.	Height of the curve of wheel tooth expressed in fractions of primitive radius of pinion.	Proportion of the total diameter of the wheel to the pinion.	The radius of the modified curve expressed in fractions of circular pitch.
60	6	0.573	0.512	8.95	0.573
70	7	0.564	0.456	9.096	0.606
80	8	0.549	0.406	9.2	0.720
80	10	0.527	0.347	7.556	Epicycloidal curve.

Starting from twelve leaves, the width of the tooth may be made equal to the space, the action ceasing even a little before the summit of the tooth. For pinions of ten leaves the epicycloidal curve acts in its full capacity. We might almost say the same thing of a pinion of eight leaves (fig. 10), the commencement of the engagement taking place about 7° before the line of centers, or a little less than half the width of the leaf. Besides, this last quantity will be slightly diminished by giving to the tooth the width indicated in the foregoing table. The modified curve would then remain applicable to pinions of six and seven leaves only.

16. In practice we are frequently called upon to determine the size of a pinion for matching a given wheel. Such a size may be determined in various ways with more or less approximation. The most reliable method is by calculation, verified by the vernier gauge.

For example, to determine the size of a pinion of six leaves gearing with a wheel of sixty teeth, let us suppose that on measuring the diameter of the wheel we find it to be fifty-two mm. Dividing this by 8.95, the proportion of the dimensions of the wheel to the pinion (fifth column of the preceding table), the result will be 0.58 mm., for the diameter of the pinion. We may also use for this purpose a proportional gauge, consulting a table of corrections, which will indicate exactly the division on which the wheel will have to be placed.

A method very much employed in factories is the taking of measurements of a certain number of teeth of the wheel, and their accompanying spaces and fractions thereof, according to the number of pinion leaves of the pinion which is to gear with the wheel. Such a method, however, requires practice and accuracy, and is not to be recommended

to the uninitiated. For such a purpose, an explanation becomes necessary. We take as a point of departure for such measurements the point of any one tooth, and next, designate by the word "interval" the distance from the point of one tooth to the next. By the number of intervals and fractions thereof, which will form an arc, the chord will correspond to the diameter which the pinion calls for. If the roundings of the pinion leaves are semi-circles, its size will correspond to the following intervals:

Pinions.	Wheels.	Intervals.
6	60	2.15
7	70	2.455
8	80	2.77
10	80	3.38
12	96	4.07

Thus, for a pinion of six leaves, the calipers placed on the point of one tooth will embrace two intervals and fifteen one-hundredths; that is to say, a little over three points of teeth.

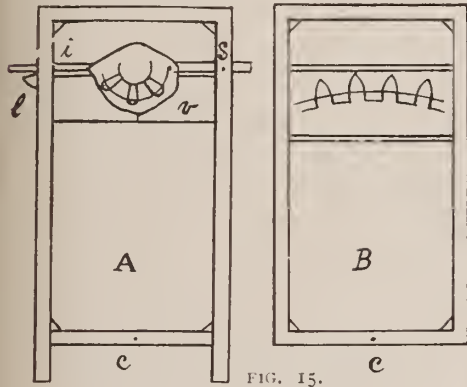

18. These given points will vary a little when the proportion of the number of the wheel and pinion is different from that given in the table; such a difference would be more decided for pinions of high number which embrace a larger portion of the circle of the wheel. For a wheel of 48 teeth for example, a pinion of six leaves should measure two intervals and one hundred and twenty-five thousandths.

In case the top of the pinion leaf, instead of a semicircle is of a more elongated form, the distance indicated would be too short. The pinion would then appear too large; it would, however, be suitable for the wheel, because its addenda only would have varied, its primitive radius as well as its addenda being in the proper proportion. The pinions of English watches, which appear to us of too large a size, are of this kind. The leaf called in French, *grain d'orge*, has an addenda of very elongated form.

19. The function of gearing in watches is extremely difficult to analyze because of the small size of the parts in contact; it is therefore advantageous to study the subject and obtain the necessary knowledge of all its bearing by the means of enlarged models, which are usually made of wood or zinc. Such models are expensive and their use is usually restricted and confined to horological schools. But an apparatus may be constructed by almost any one, which is very simple and at the same time exact. This

A. WITTNAUER,

30 MAIDEN LANE, * NEW YORK.

Manufacturer and Importer of

WATCHES

LONGINES,
AGASSIZ
AND
MONARD.

MOVEMENTS FITTING ALL SIZES AMERICAN CASES.

THOROUGHLY ADJUSTED TIMEKEEPERS FOR RAILROAD USE.

Also, a very complete line of Accurate Timing and Repeating
Watches in Stock.

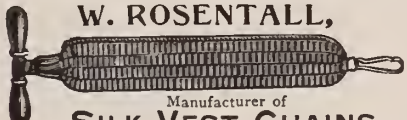
W. ROSENTALL,

Manufacturer of
SILK VEST CHAINS,
79 NASSAU STREET, NEW YORK.
Send for Selection Package with reference.

ELGIN HOROLOGICAL SCHOOL
ELGIN, ILL.
SEND FOR CIRCULAR.
Repairing for the trade. Repair price list free.

WE MAKE FOR YOU TO SELL

The following lines, all of the best stock and made by the finest skilled workmen. F. & B. stamped on our cards, tags, etc., means that we know what we are about when we guarantee our goods:

- Ladies' and Gentlemen's Chains that are right; will wear ten years.*
- Lockets and Charms in endless variety.*
- Bar Pins and Cuff Pins, fine in quality and cheap in price.*
- Sleeve Buttons, "The Mount Hope," the best in the world.*
- Chain Mountings for Hair and Silk Chains.*
- Bracelets, Curb with padlock or snap, Polished plain, Roman plain chased bright, chased Roman, also silver oxidized.*
- Stanley, Jefferson and Washington Bracelets in solid silver.*
- Glove Buttoners, the interlocking.*
- Searf Pins, Jersey Pins, Bangles, Earrings, Bead Necks, Neck Chains and Garters.*

FOSTER & BAILEY, Providence, R. I.

consists of two rectangular frames (fig. 15) of wood, A and B covered by transparent or translucent paper. These two frames are placed one over the other and are united by a pin C. This pin represents the centre of the wheel. The two frames are now held almost vertically between the operator and the light, the one marked A being placed behind and intended to remain stationary, while B is so arranged as to allow it to be moved around the pin, C. To the latter we fasten the drawing of the wheel, making it concentric with pin, C.

On the back of the frame, A, is fastened a piece of glass, *v*, at such a height as may contain the point of gearing and a line marked thereon which will represent a portion of the line of centres. The drawing of the pinion is placed before the glass and fastened by its centre on a rule, *i*, placed across the back of the frame. This rule is pivoted at one of its extremities, *s*, on one of the sides of the frame and may now be moved by an eccentric, *l*, to elevate or depress the pinion and to cause it to approach to or recede from the wheel. The graduated circles traced on the wheel or on the pinion will permit us to appreciate the uniformity of the action; for the purpose the line of centres will be used as an index to read the degrees traversed by such mobile.

The apparatus described is useful to show the action of the different forms of teeth and leaves. It will show the effects of a depth being too deep or too shallow. In the first

case the tooth at the end of its action when it drives by its sharp point, slides rapidly on the leaf of the pinion, while the next tooth drops on the leaf which it is about to drive. If on the other hand the depth is too shallow, the action before the line of centres takes place too soon and produces an abutting. We will thus be enabled to see the importance of having the two mobiles at the proper distance from each other. We know that this distance coincides with the point, where the two primitive circles are tangent. The modified curve has certainly the advantage of increasing the limits between which the gearing is in good condition.

22. We will conclude our discussion by calculating the dimensions of a wheel of 60 teeth and a pinion of 6 leaves. We will assume that the distance of centres is 3.75 mm., which would approximately be convenient for a movement of 13 lignes.

To preserve the proper proportion between the primitive radii and the number of teeth and leaves the radius of each mobile will occupy in the distance of centres a length proportionate to its number of teeth and leaves. We would take then for the wheel $\frac{60}{66}$ of the distance and for the pinion $\frac{6}{66}$. We see that the denominator of these fractions is obtained by adding the number of teeth to the number of leaves.

Then $\frac{60 \times 3.75}{66} = 3.409$ Primitive radius, of the wheel,
and $\frac{6 \times 3.75}{66} = 0.341$ Primitive radius, of the pinion.

The height of the curve of the tooth being a fraction of the primitive radius of the pinion, we will have according to the table given:

$0.341 \times 0.512 = 0.17459$ height of the curve, and the total radius of the wheel being equal to its primitive radius argued by the height of the curve, we have

$3.409 + 0.17459 = 3.58359$ total radius of the wheel, and $3.58359 \times 2 = 7.167$ mm., total diameter of the wheel.

As to the total diameter of the pinion, if the top of the leaf is a semicircle, its primitive radius with the addition of half the width of the leaf will give its total radius. We find the width of the leaf by calculating the length of the primitive circumference of the pinion and dividing this length by the space which embraces a leaf. In proceeding in this manner we find that if the primitive radius of the pinion is known its total diameter may be found by multiplying its primitive radius by a certain constant for a given number of leaves (2.349, if it is a pinion of six leaves).

We will then have $0.341 \times 2.349 = 0.801$ total diameter of the pinion. The proportion of the total dimensions of the wheel to the pinion, of which mention has been made before in this discussion, is obtained by dividing the total diameter of the wheel by that of the pinion:

Then $\frac{7.167}{0.801} = 8.95$ in proportion of the wheel to the pinion.

JEWELERS seeking the latest ideas in Cut Glass are invited to call and inspect our new pattern,

"THE AVON,"

pronounced by connoisseurs the handsomest ever placed on the market.

FACTORY,
HONESDALE, PA.

T. B. CLARK & CO.,
53 Park Place, New York

MUSICAL JACOT & SON,
298 Broadway,
New York
Send for Catalogue.
BOXES.
Musical Boxes Repaired.

GILBERT T. WOGLOM,
BLACK MAKER OF
JEWELRY. Pearl Ornamented
and Plain
ONYX
GOLD MOUNTED.
32 & 34 John St. New York City.

A. PINOVER & Co.,

IMPORTERS OF

DIAMONDS



AND

Manufacturing Jewelers,
25-29 ANN STREET,
Cor. Nassau Street, NEW YORK.

Novelties in Diamond Mountings.

THE **RYDER & DEARTH**
DESIGNERS & ENGRAVERS

Fine Commercial and Copper-Plate Printers.

A Specialty of

Jewelers' Printing, Cuts and Electrotypes.

Headquarters for JEWELERS' CARDS.

BEST WORK,

PROMPT DELIVERY.

LOW PRICES.

No Order Too Large! None Too Small!

146 Westminster Street,

PROVIDENCE, - RHODE ISLAND.



NEW YORK OFFICE,
PRESCOTT BUILDING,
ROOM 40. SAMPLES ONLY.

WORKS, BLACKSTONE & GAY STS.
TAKE PRAIRIE AVE CAR

Providence, R.I.



Easy Lessons for Opticians.

BY C. A. BUCKLIN, A.M., M.D.

We will next consider the common unclassified peculiarities of vision which lead persons who are not benefitted by glasses to consult opticians.

The existence of a visual obscurity may always be detected and treated by the various methods of examination already described. There are incidental complications which the optician meets during his attempts to discover the existence of mechanical ocular defects which may be relieved by optical appliances. When they are discovered they give a reason for the defective vision which by optical means is not relieved to the satisfaction of the patient. Occasionally one will meet a person desiring glasses who complains of smoky vision which does not disappear by the correcting of any error of refraction found to exist. Such persons have acute choroiditis; they should have smoked glasses, and the responsibility of such cases should be avoided by recommending them to consult a competent specialist, better if of their own selection.

Glauconia in its early stages is also a difficulty which the optician stumbles against in persons over forty. The reduction of accommodation is more excessive than should exist at this age of the patient. This reduction of accommodation is actively advancing, the pupils are dilated, they complain of seeing rings about the lights in which there is a display of spectral colors, and they always have a limited field of vision on the nasal side. This last feature is strikingly characteristic of the trouble.

Another peculiar difficulty for which the public seek satisfactory lenses without success is "night blindness." The individual may have perfect vision during the day, but at night he becomes so blind that he is unable to find his way about. This difficulty is due to a chronic form of retinitis. The field of vision is considerably limited in all directions, and the defect, unless complicated by some decided error of refraction is not benefitted by glasses.

Micropsia (small vision); megalopsia (large vision); and metamorphopsia (irregular vision), are peculiarities of vision frequently encountered by the optician. These defects are due to a previously existing retinitis or choroiditis. They are produced by such a displacement of the rods and cones of the retina that the rods and cones upon which images from small objects formerly fell are now fallen upon by images from large objects; consequently large objects appear small.

In the case of large vision, the rods and

DIAMONDS.

Wm. S. Hedges & Co.,
Importers of Diamonds,

And Manufacturers of DIAMOND JEWELRY.
 No. 170 BROADWAY,
 S. E. Cor. Maiden Lane, } New York.
 27 Holborn Viaduct, London.



“ S ”

A “NOVELTY” in Marquis Rings.

ASK YOUR JOBBER FOR

STERN BROTHERS' DIAMOND MOUNTINGS,

42 MAIDEN LANE, N. Y.

MAXHEIMER & BERESFORD,

MANUFACTURERS OF

FINE DIAMOND JEWELRY,

No. 3 Maiden Lane, New York.

ORDER WORK A SPECIALTY

TO THE TRADE ONLY.

Balance Staffs, - 60 Cents.
 Inserting Pivots, 40 Cents.

ALL OTHER WORK IN PROPORTION.

SEND FOR PRICE LIST.

THOMAS JUZEK & CO.,
 ELGIN, ILL.

R. A. Kipling

Importer of Precious Stones

31, Union Square
 New-York

19, Rue Drouot
 Paris

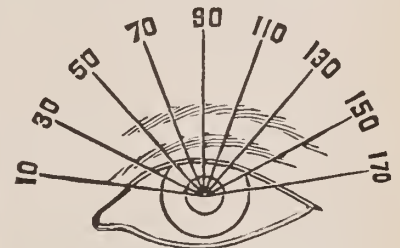

SEND TO

GENEVA OPTICAL CO.

23 Washington St., Chicago.

FOR PRESCRIPTIONS, REPAIR AND ORDER WORK
 PROMPTLY AT LOWEST PRICES.

SEXTON BROS. & WASHBURN,

41 MAIDEN LANE, NEW YORK,

MANUFACTURERS OF

FINE JEWELRY,

INCLUDING A FULL LINE OF MOUNTINGS.



PROMPT AND CAREFUL ATTENTION GIVEN TO SPECIAL ORDER WORK.

A. N. CLARK, PLAINVILLE, } MANUFACTURER of the Celebrated
 CONN. }

LOOP WATCH KEY.

The best for the price in the World. Size
 of Square stamped on each Key.

Also Key Rings, Watch Case Springs,
 Jewelry Tools, Tweezers, Etc.

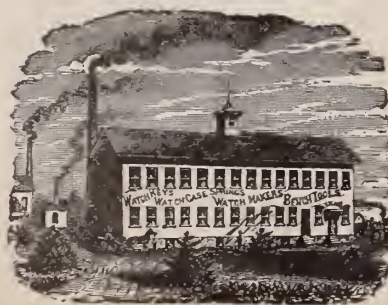

SEND FOR PRICE
 LIST.

SOLD BY ALL JOBBERS IN THE LINE
 AT MANUFACTURER'S PRICES.

AIKIN, LAMBERT & Co.,

23 Maiden Lane,

NEW YORK,

Manufacturers and Exporters of

Fine Gold Pens, Pencils,

TOOTHPICKS, HOLDERS,

And Novelties in Silver, Pearl, &c.



THE BEST FOUNTAIN PENS.

New Assortments in SHOW CASES and FANCY TRAYS for JEWELERS.
Price Lists and Catalogues for intending Purchasers.



Also American and Swiss Watches.

DIAMONDS, Loose and Mounted.

Gold and Silver Thimbles,

CHAINS and JEWELRY in New and Staple Patterns.

S. COTTLE & CO.,

MAKERS OF

FINE JEWELRY AND SILVER

NOVELTIES,

No. 860 Broadway NEW YORK.

HENRY FERA,
IMPORTER OF DIAMONDS,

AND DIAMOND BORTZ,

Diamond Cutting and Polishing Establishment,
10 Maiden Lane, NEW YORK.

ESTABLISHED 1837.

TAYLOR & BROTHER,

Old House READ, TAYLOR & CO.,

IMPORTERS OF

Diamonds and Pearls

AND

Manufacturers of Diamond Jewelry,

860 BROADWAY, NEW YORK.

Branch Office, 1½ Maiden Lane.

21 HOLBORN VIADUCT,
LONDON

206 KEAFNEY ST.
SAN FRANCISCO.

DAY & CLARK,

MAKERS OF

FINE JEWELRY,

BEAD NECKS AND BEAD BRACELETS,

CURB AND LINK BRACELETS

STRICTLY 14 KT.

- 10 MAIDEN LANE, N. Y.

cones of the retina become so crowded together that images from small objects fall upon retinal elements upon which formerly only images from large objects fell, consequently small objects look large.

In irregular vision, the rods and cones are displaced in a corresponding irregular way, the most frequent complaint from the individual being that the ruled lines of writing paper or the lines of print appear undulatingly crooked.

The correction of any co-existing error of refraction will be beneficial, but do not be discouraged if it is not satisfactory to the patient. Such eyes cannot be made satisfactory, and it is very fortunate that these difficulties are usually limited to one eye.

Another class of difficulties are also encountered by opticians and deserve a passing remark. These are the hemi-anopias. These individuals have temporary or permanent blindness of corresponding halves of each eye. Thus, a functional or organic lesion, which occupies the *right* optic tract produces right-sided hemi-anopia or blindness of the right sides of both retinas. Such a patient complains that all objects appear *sharply* split in the centre, and while the right side of the object remains distinct, the left side is entirely lost. Similar lesions in the left optic tract produces left sided hemi-anopia in which defect the right side of all objects have disappeared. Occasionally bi-nasal hemi-anopia has been observed while bi-temporal hemi-anopia is a very rare defect. The right and left sided hemi-anopias are probably the only classes of this defect that the man of average experience will meet. They appear in nervous persons as the result of functional nervous disorders or as a result of tumors of the brain. When they are caused by functional nervous troubles they disappear with time and the general improvement of the health; when caused as a result of organic disease of the brain, the trouble is permanent except in the single instance where it is from specific disease. These cases are all medical, and are not in any way benefitted by any optical treatment.

The reduction of the distinctness of vision by deeply-smoked lenses may be used as a palliative measure from which relief is obtained through the imagination of some nervous persons.

Conical cornea is another subject which should receive the attention of that class of opticians who are interested in knowing what cannot be done and who are not entirely absorbed with the narrow-minded idea that it is useless to understand the nature of any defect which they cannot promptly relieve by proper lenses.

The cornea frequently atrophies from disease and bulges forward in the form of a cone. This defect has received the name of "Conical cornea." The reflection of light from the cornea in a well developed case of this defect is so peculiar that when once observed it will never be forgotten. The great disturbance to the refraction of the eye where the cornea has assumed the form of a cone is more easily imagined than ex-

pressed. The vision in these cases is exceedingly defective.

These cases are divided into two great classes. The one that has a conical cornea, the apex of which is perfectly clear, and through which the refraction is more perfect than through any other portion of the cornea. The second class have an opacity at the apex of the cornea and the light must come to the retina through peripheral portions of the cornea.

The treatment of these cases by optical means has never been considered in any thing like an intelligent way in ophthalmic literature; consequently I can only give my readers the benefit of my own personal experience. This is best told by describing a few illustrative cases which have come under my observation.

Mr. B., 25 years of age, has a well developed conical cornea, with no practical vision for the distance, and he is also entirely unable to see at the working distance. He is unable to read any type in commercial use. The apex of each cornea is opaque, the vision cannot be sufficiently improved by dilating the pupil to enable him to read, although such dilation slightly improves distant vision. He has become fully incapacitated to follow his usual vocation of stenographer. With a plane glass, which has a deep black coating of varnish $\frac{3}{16}$ of an inch wide across the centre, in a horizontal direction, he is able to look under the black line and read the daily paper, and when looking over the black line he sees fairly well at a distance. This is the first time that this form of glasses were ever used. The philosophy of their action is as follows: the black surface gives a slightly dilated but thoroughly adjustable pupil; it also cuts off the disturbing rays of light which would come through the semi-opaque and badly distorted corneal apex.

Case No. 2. An engineer of about fifty, of Trenton, N. J., has thoroughly developed conical cornea. I find him with a-6 axis 180 cylinder before one eye and a-6 cylinder axis 90, before the other. With this combination he can see the water and steam gauges of his boilers; without these glasses he is perfectly helpless; with no other combination of lenses can he see equally well.

The next best combination he can find is to reverse his lenses so that the glass of the right eye stands before the left. The poor fellow was painfully solicitous that by some accident he might lose his glasses and never be able to replace them.

The philosophy of the action of these lenses are as follows: This man had a clear apex to both corneas. The refraction of one apex was a little more regular than the other. He was obliged to hold objects too close to make bi-nocular vision possible. Any cover for one eye which in any way prevents the usual amount of light from entering the eye not in use allowed the pupil of the eye in use to dilate slightly, and vision was impossible.

The concave six cylinder axis, 180°, corrected the astigmatism which existed in one cornea, while the six cylinder at 90° made

the vision of the other eye so very bad that it did not confuse vision by attempting to unite in the act of bi-nocular vision, and it did not prevent the usual amount of light from entering the eye not employed in the visual act. The moment anything dark was passed before the eye not used, if a card was held closely before this eye, the other eye refused to perform its visual work.

I could detail several other cases of a somewhat similar nature, but the two cases given illustrate very well the two classes of conical cornea into which I have chosen to divide this defect. My readers may be incredulous, but these cases are still living, I believe, and can be produced.

The operative methods are fully discussed in ophthalmic literature, but as no positive results can be promised by them, I am reluctant to operate on an individual depending upon his eyes for his living, so long as by any optical contrivance he is enabled to follow his daily vocation.

Repairing Colored Gold Jewelry.

JUDGING from the inquiries of some of your readers, says A. O. in an exchange, I venture to think that a few practical hints upon the repairing of various classes of jewelry will be very acceptable and useful, as the repairing branch of the trade becomes more and more difficult every year, owing to the demand for lightly made goods, which when broken require all the

ingenuity and care that is possible to avoid getting into a serious difficulty; for the success of repairing depends very considerably upon the way the job is commenced. Perhaps the most difficult of all the repairs is that of thin *colored gold work*, and numerous and annoying are the flukes that occur to workmen who start about the job before having made a careful and thorough examination of the article to be repaired, by this means getting into a fix at the very commencement of it, which, in a good many cases, could have been avoided by a little thought and care.

Does repairing pay? In answer to this question I must certainly say, yes—provided the same amount of attention is given to it that would be given to making new work. That is, unfortunately, not always done.

Some manufacturers do not care to be troubled with repairs, and when they do take them in, they are handed over to an inferior workman, who is "good enough for such jobs." This is a mistake; it takes a man of considerable skill and long experience to make repairing pay, as otherwise the accidents will consume all the profits that would otherwise be made. The repairer must be on the alert for all the tricks that are often used to patch up a piece of work which has been repaired several times; he must know how to distinguish an old gilt article from a colored one, and be able to find all the weak points and thin places before attempting to solder or repair in any way, or

he may find himself in a "peck of trouble" before he has been working at the job for five minutes. A few suggestions showing how to avoid these traps for the unwary is what I will attempt to give.

Upon receiving a colored gold article to be repaired especially if it is an old one that may reasonably be expected to have been repaired several times before, the first thing to do is to ascertain whether it has been repaired with soft lead solder anywhere, as if this is the case, and you attempt to hard solder without removing the lead, the result is that the soft solder burns through the surface of the gold and thus destroys it in such a manner as to prevent a good job being made of it. If, upon examination, you find soft solder present, remove as much as possible by scraping, and then immerse the article in a solution of four parts muriatic acid to one part of water—this should be done in an earthenware pipkin, and not a metallic vessel; making the solution warm will remove the solder quicker, but it is not altogether necessary, as the cold solution will do it and is more convenient, the warm acid giving off more fumes than the cold. When the solder is gotten rid of the article should be boiled in clean water in a copper pan, to remove all traces of acid.

Now, before attempting to hard-solder the part required to be repaired, cover the work with a solution of borax rubbed fine in water and mixed with charcoal dust in a thin paste. Apply this all over the article with a

"WE CONSIDER"

OUR WEBSTER-WHITCOMB Lathe, in fact, we KNOW it is

THE

BEST LATHE MADE.

SO DO THE FOLLOWING PARTIES WHO HAVE THEM:

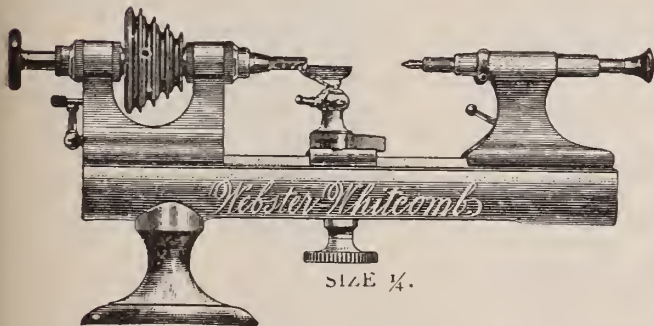

W. H. MAIRE, of Princeton, Ky., writes:

"The lathe is just at hand, and I assure you it is just what I want. It is as near perfection as they get, I think."

S. T. RUSSELL, of West Plains, Mo., writes:

"The lathe is a dandy in every respect. It gives perfect satisfaction in every respect."

OSCAR J. FUCHS, of Chillicothe, O., writes:

"My Webster-Whitcomb lathe is giving me No. 1 satisfaction, and I expect I will have to buy some more attachments soon."

GEO. E. TEW, of Seattle, Wash., writes:

"My lathe is perfectly satisfactory, and I consider it the best lathe made."

C. A. BECK, of Franklin, Ind., writes:

"I think more of my lathe than I do of myself."

TAINTOR & McALPINE, of Easthampton, Mass., writes:

"We have one of your fine Watchmakers' lathes with full set of chucks, universal head, slide rest, filing attachment, etc., and find them perfect tools."

With every lathe we send the following guarantee:—

"This certifies that the lathe marked 'American Watch Tool Co., No. —' was made by us from the best materials, on the most approved plan, and is a reliable lathe. For any defect in material or workmanship we hold ourselves responsible. Notify us promptly of any faults.

"Waltham, _____

By _____"

This guarantee is also signed by the inspector who has the final inspection of the work. For several years past we have tied upon every lathe a tag of caution and instruction. All purchasers are requested to demand these documents with the lathes they buy. Remember our address:

AMERICAN WATCH TOOL CO.,

STONY BATTER WORKS

WALTHAM, MASS.

camel's hair pencil; then anneal gradually, being careful not to make too hot. Afterwards boil out in a weak mixture of nitric acid and water, and dry in hot sawdust—fine boxwood sawdust is the best as it does not give out the resinous compound that common woods are liable to do. You will then be able to solder in the ordinary way, with either gold or silver solder as the case may require. If the article is strong enough to stand recoloring, use gold solder; if it is too far gone for this, use silver solder and gild.

It sometimes occurs that the article to be repaired has been so worn and patched as to make it quite impossible to use hard solder of either kind. In this case there is nothing for it but to soft solder, and this may be done much neater and better than is often the case. The important thing to remember is that soft solder will not take where there is the smallest trace of dirt or grease. Commence then by washing out the work in hot soda-water and soap, with a moderately soft brush, dry in hot sawdust and then scrape the parts to be soldered together bright and clean. If any part has to be added, such as a joint or catch on a plate, put a coating of solder on the sides to be mitred together by warming them in the soldering gas or lamp, and rubbing a copper point, which has already been

tinned, over the surface, using a little soldering fluid or Venice turpentine. Then place the two surfaces together, using a little fresh fluid, and warm them with a small blast from blow-pipe until the solder runs, when the whole will be cleanly and soundly joined, provided the two surfaces fit each other. This method is far superior to that of putting small panels of solder along the mitred edges in hard soldering, and trying to draw it through, as it is generally a failure, the solder running about the outside surface and causing a deal of trouble afterward.

Now, if fluid has been used, the article must be washed out in cold water, hot water will only fix it on and make it dirty for finishing. If Venice turpentine has been used as a soldering medium, wash out in ordinary turpentine, and dry in hot sawdust; after trimming up, polishing a little where necessary, washing out in hot water and soap, and again drying in saw-dust, it will be ready for gilding, sand blasting, etc.

A Hero in the Trade.

HEROES among traveling men are not scarce, and one of the number is George Wettstein, traveling salesman for the well-known firm of C. T. Happel & Co., wholesale jewelers of Chicago. Mr. Wettstein has been in the employ of the firm for twelve

years and is an energetic, pushing man. Just now, however, he is taking a temporary lay off. One day recently he left Cedar Rapids, Ia., on the Burlington, Cedar Rapids & Northern road to go to Elgin, Ill. The train rolled along at the rate of forty-five miles an hour, when it was suddenly derailed and the cars fell down a thirty-five-foot embankment. Mr. Wettstein crawled out of the wreck in a dazed condition, bruised and bleeding from a bad cut in his forehead. His first thought was of his samples, which were worth, at the lowest calculation, \$30,000. He made his way to the baggage car where his trunks were. The car was on fire, but Mr. Wettstein was not daunted, and breaking in a window he went into the car, which was on its side, and groping his way through the smoke, found his valuable trunks. It was the work of a moment to open them and he hastily lifted the trays out and passed them to a man on the outside. He also got one of the trunks out. Crowding samples into it he made his way to Elgin where he is now laid up for repairs. Mr. Wettstein is injured internally but will recover.

We admire the initial copy of The Circular. You have made a good departure in publishing weekly, and one that cannot fail of success.
Montgomery Bro.

JAMES P. SNOW.

ESTABLISHED 1834.

CHAS. E. WESTCOTT.

SNOW & WESTCOTT,

SUCCESSORS TO G. & S. OWEN & CO.,
MAKERS OF

FINE JEWELRY,

Lace Pins, Ear Rings, Scarf Pins, Sleeve Buttons, Sash Pins, Collar Buttons, Bracelets, Studs.

All Goods sold by us are exclusively of our own manufacture and are warranted 14 K. Fine, and stamped as such when possible.

No. 3 MAIDEN LANE, NEW YORK.

**STOP!
START!**

THE WALTHAM SCHOOL OF HOROLOGY,

D. D. PALMER, Teacher and Proprietor.

Best Advantages in the Country for Horological Instruction.

All branches under the personal supervision of D. D. PALMER, for a number of years in charge of the Adjusting Department of the Waltham Watch Co. POSITIONS GUARANTEED TO APT PUPILS. For terms and other particulars, address

D. D. PALMER,
WALTHAM, MASS.

Specialty of Difficult Repair Jobs.

OTTO GAS ENGINE WORKS

SCHLEICHER, SCHUMM & CO.

PHILADELPHIA.

CHICAGO.

20,000 SOLD.

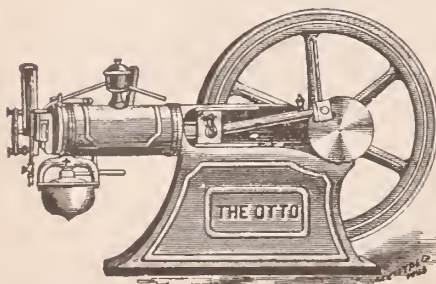

Guaranteed to consume 25 to 75 per cent. less Gas than ANY other Gas Engine doing the same work.

Our 1-horse power engine is largely used by Jewelers.

Price recently reduced to \$325 at Factory in Philadelphia.

Send for Circular and Reference List relating to this Size.

ROBERTSON & LEBER,

GOLD, SILVER AND

PLATINUM

REFINING.

PLATINUM SCRAPS MELTED

13 & 15 Franklin Street, Newark, N. J.

JEWELERS' SWEEPINGS A SPECIALTY.

PLATINUM FOR SALE.



**A Wonderful
TOOL
FOR THE BENCH.**

Instantaneous in Its Work.

Dividing the inch into one thousand parts. A most practical tool for watchmakers for gauging from a hair-spring to a main-spring. Non-comparable for a height and depth gauge. Instantaneous for hair-spring work.

For sale by all Jobbers.

NORDMAN BROTHERS,
120 Sutter St., SAN FRANCISCO, CAL.
Sole Agents for the United States.

Brief History of Gold and Silversmithing.

(Continued from page 45, March 4.)

PART IV.

LOUIS XV. PERIOD.

ONE of the most lovely pieces designed by Juste Meissonnier must have been the silver jewel casket reproduced by our fig 21. It seems as though the artist who decorated that case, made to contain magnificent necklaces, bracelets and brooches, thought that the delicacy of the work bestowed on the receptacle ought to proclaim that of the contents. The outlines of that casket are exquisitely graceful. The curling ornaments on the body of the piece were engraved and the bunches of roses as well as the shells were embossed. The two medallions, exhibiting a pretty scene in *re-poussé*, greatly add to the beauty of the ensemble. On the face showing there is a Venus riding on the sea; the figure is perfectly modelled; the goddess' wide-awake son is soaring away. We

gathering of roses over which two doves appear to be engaged in a sweet conversation.

Whenever the reader comes across a jewel casket or a snuff box in gold or silver, of the eighteenth century, he should never fail to examine the joint (hinges). All the divided parts of it, at once strong and slender, are placed so close together that they seem to be one, even when you lift the lid and move it slowly back. Besides they are seldom sali-

which is preserved at the National Library. Germain Bapst, who has endeavored to write a true history of those silversmiths whose family's name has been given to him as a Christian name, says that Pierre Germain, the last, was in no way related to the others. I think it unnecessary either to confirm or to refute this statement, since we can derive from it no useful knowledge. All we want to know is whether that artist

metal-worker has made beautiful pieces.

Among the plates of Pierre Germain's valuable book I have chosen one for reproduction, in preference to the others, thinking that it would give almost a thorough idea of his style as a silversmith. At the time of Louis XV. wealthy people possessed toilet sets, a plain one for use, and another, richly decorated, for show. Both consisted of the same pieces, sometimes in gold, but more often in

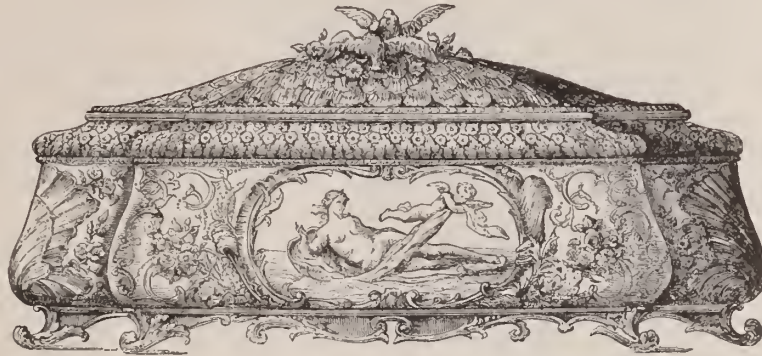

FIG. 21.—JEWEL CASKET BY JUSTE MEISSONNIER.

ent. Very few among the modern jewel caskets or boxes are as neatly done. In fact, on a pseudo-Louis XV. or Louis XVI. snuff box, the fraud might often be detected by merely looking at the joint.

Among a series of plates published at Amsterdam in 1753, by Ph. Métayer, who was an engraver and chaser, I saw a handsome cup (fig. 22) which may have been designed for George II., King of England, although there is an important alteration in the arrangement of the arms, on which the motto *Dieu et mon Droit* does not appear. Leaving aside such supposition and simply considering the cup as it is reproduced by our fig. 22, we cannot help admiring it. The decoration of the stand is very elaborate, yet its outlines are as well defined as a rich rococo work may be. The cup is evidently adorned with four handsome medallions, all alike, imitating shell fragments symmetrically overhung with garlands, and divided at the base by smaller medallions of the same style. Each of the large escutcheons contains an allegorical infantine scene. The one we see exhibits undoubtedly on a tiny scale Love and Power, hand in hand, or rather Love devotedly offering itself to Power, who accepts the tender homage with a condescending smile; the figures rest on clouds (!); artists enjoyed great liberties in those times, which might account for the free but very striking interpretation of English arms on the cover.

silver. The articles of a *toilette simple* were unadorned, with the exception of the candlestick, which was slightly decorated. All those items of an eighteenth century toilet set, as represented in our fig. 23, had a beauty of their own in spite of their plainness, on account of their varied and elegant outlines. The water-jug and its basin are worthy of notice, especially the



FIG. 22.—CUP WITH ENGLISH EMBLEMATA.

remark no sign of conventional mythology about that scene; the grace of the attitude is thoroughly in keeping with the style of the surrounding details. The lid is covered with shells and surmounted with a

Pierre Germain, the second, who flourished in Paris as a silversmith toward the end of Louis XV.'s reign and at the beginning of the following reign, published, under the title of *Eléments d'Orfèverie*, a series of plates (a hundred altogether) in two books, a copy of



FIG. 23.—JUG BY PIERRE GERMAIN.

latter, in the shape of a boat; but the various boxes made to contain the gloves, the jewels, the beauty spots, the powder, and the coloring roots for the lips, particularly attract our attention. We may also remark

the rim of the tray on which are placed the two goblets for the morning wine.

The handsome silver ewer reproduced by our fig. 24 is believed to have been made by Pierre Germain. The fluted work on it is neatly done; the flowers and reeds, in repoussé, spreading around the lower part produce a pretty effect, and the handle is a perfect model of its kind. The front of the ewer is occupied by embossed arms, consisting of

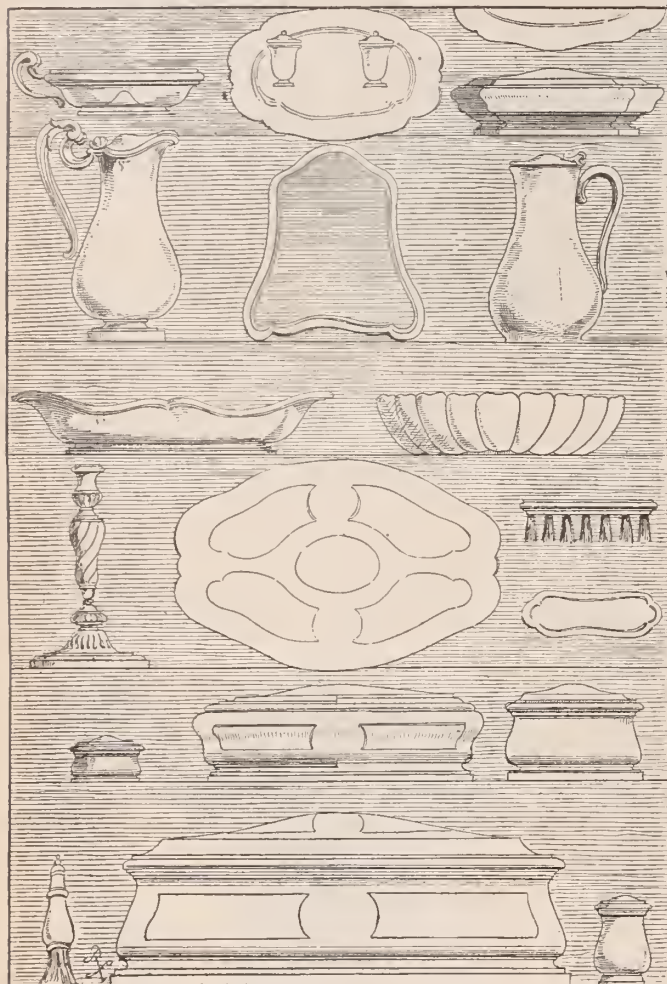

FIG. 23.—TOILET SET, TIME OF LOUIS XV.

two escutcheons with a coronet, resting on a decorative waterfall.

Juste Meissonnier, who had written a book on vegetables considered as elements of decoration, designed numerous soup tureens and other vessels exhibiting carrots, turnips, etc., on their covers. Sometimes fishes or game arranged in crowning trophies replaced vegetables.

The Louis XV. style has been already described in THE CIRCULAR (in the series on Clock Decoration, a year ago.) I therefore need not dwell on it. Among designers of that period, those who were also silversmiths have shown that it was possible to make articles at once useful, and extremely varied in shape and decoration. They have, through a succession of curved lines skilfully opposed to each other, obtained surprising effects. If we manage to acquire the delicate taste of our ancestors, let us apply it in our own way. They took hints from nature and worked them out according to the ruling humor and

fancy. We may do the same, only we must bear in mind that we live in other times.

(To be continued.)

To Polish Metals.

METALS are polished either by burnishing or buffing. The process of burnishing consists in rubbing down all the roughness by means of a highly-polished steel or agate tool—none of the metal being removed. The action of the burnisher appears to depend upon two circumstances: First, that the harder the material to be polished the greater lustre it will receive; the burnisher is, therefore, commonly made of *hardened steel*, which exceed in hardness nearly every metallic body. Secondly, it depends on the closeness of the contact between the burnisher and the work; and the pressure of the brightened burnisher being, in reality, from its rounded or elliptical section exerted upon only one mathematical line or point of the work at a time, it acts with great pressure and in a manner distinctly analogous to the steel die used in making coin. In the latter case the *dull* but smooth blank becomes instantly the bright and lustrous coin, by virtue of the contact produced in the coining press between the entire surface of the blank and that of the highly polished die.

It by no means follows, however, that the burnisher will produce highly finished surfaces, unless they have been previously rendered smooth and proper for the application of this instrument. A rough surface having any file marks or scratches will exhibit the original defects, notwithstanding that they may be glossed over with the burnisher which follows every irregularity; and extensive pressure, which might be expected to correct the evil as in coining, only fills the work with furrows, and produces an irregular indented surface, which by workmen is said to be *full of utters*.

Therefore, the greater the degree of excellence that is required in burnished work, the more carefully should it be smoothed before the application of the burnisher. This tool should also be cleaned on a buff stick with crocus immediately before use; and it should generally be applied with the least degree of friction that will suffice. Cutters generally consider that burnishers for steel are best rubbed on a buff stick with the finest flou,

emery; for silver, however, they polish the burnisher with crocus, in their usual way. Most of the metals previous to their being burnished, are rubbed with oil, to lessen the risk of tearing or scratching them, but for gold or silver the burnisher is commonly used dry, unless soap and water or skimmed milk are employed. For brass furniture, beer or water, with or without a little vinegar, is preferred for lubricating the burnisher.

Buffing is performed by rubbing the metal with soft leather, which has been charged with very fine polishing powder. The rubbing is sometimes done by hand, but more frequently the buff is made into a wheel which revolves rapidly in a lathe and the work is held against it. The polishing powder that is selected must be chosen with special reference to the metal that is to be buffed. Thus, for steel and brass the best polishing powder is crocus or rouge. The hardest part of the rouge must be selected and great care should be taken to have it clean and free from particles of dust and sand which would inevitably scratch the article polished and render it necessary to repeat all the previous processes of filing, grinding, etc. Soft metals like gold and silver may be polished with comparatively soft powders, such as prepared chalk or putty powder (oxide of zinc).

When metals are to be polished on the lathe, the process is very simple. After being turned or filed smooth, the article is still further polished by means of fine emery and oil applied with a stick, and in the case of rods or cylinders, a sort of clamp is used so that great pressure can be brought to bear on the part to be polished. The work must be examined from time to time to see that all parts are brought up equally to the greatest smoothness and freedom from scratches, and as fast as this occurs, polishing powder of finer and finer quality should be used, until the required finish is attained.

In polishing metals or any other hard substances by abrasion, the great point is to bring the whole surface up equally. A single scratch will destroy the appearance of the finest work, and it cannot be removed except by going back to the stage to which it corresponds, and beginning again from that point. Thus, if in working with a smooth file, we make a scratch as deep as the cut of a bastard file, it is of no use to try and remove this scratch with the smooth file; we must go back, and taking a bastard file make the surface as even as possible with it, and afterward work forward through fine files and polishing powders.

Robert Stoll, New York, received congratulations over the medal he recently designed and made for the citizens of Newburg, N. Y., to be presented to Skater Joseph Donoghue. The head consists of an eagle with spread wings, from tip to tip of which extends a streamer. Attached to the beak of the eagle is a bar, and inscribed on the streamer and bar are the words, "Presented by the citizens of Newburg, N. Y."

The Other Side of Life.

LOTS OF JEWELRY.

KNOWLES.—You wouldn't think that that man over there possesses thousands of dollars' worth of jewelry and diamonds.

BOWLES.—Hardly. Is he a miser millionaire?

KNOWLES.—No. He keeps a jewelry store.

TIME IS MONEY.

RELEASED PRISONER.—I want my \$15,000.

WARDEN.—We have no money of yours.

RELEASED PRISONER.—Haven't I just done 10 years' time?

WARDEN.—Well?

RELEASED PRISONER.—"Time's money." Let's have \$5,000 and call it square.

BEYOND CUPID'S DARTS.

MISS ALICE (visiting De Longair Dauberre, in his studio)—I should think you would fall in love with the model of such a beautiful woman you are painting.

DE LONGAIR DAUBERRE.—I have never thought of the thing.

MISS ALICE.—How improbable!

DE LONGAIR DAUBERRE.—No. You see my wife was the model.

HE SAW THROUGH SPECTACLES.

MRS. CHIDWIDLER.—You grow crustier every day, and are becoming a conglomeration of sourness.

MR. CHIDWIDLER.—The world is made of thieves and traitors.

MRS. C.—Oh, you look at life through spectacles.

MR. C.—No doubt, I must, if I have thought you a pretty woman.



THE WRONG KIND.

HE.—"I think I'll have to use glasses."

HIS WIFE.—"Well, dear, you always did use them; but they never got higher than your lips."—*Judge.*

VERY ACCOMMODATING.

COLLECTOR.—You cannot pay the bill today, eh? Well, how many times do you want me to call any way?

MERCHANT.—I assure you, my dear man, that I don't care if you never call again.

THE ENGAGEMENT RING SEASON.

JEWELER'S WIFE.—Your affairs are in a bad shape, Peter?

JEWELER.—Very, but I think I'll pull through. My creditors have extended my paper to the end of seaside season.

THE WATCH TRIED HARD TO KEEP TIME.

JEWELER.—I claim that the watch I sold you is a good time-keeper.

KNOWLES.—It's a deuced good time-keeper. It makes such frantic efforts to keep the time continually that it stops time in its flight about once every hour.

WILLIAM B. DURGIN,

Designer and Maker of Wares in **STERLING SILVER,**

CONCORD, NEW HAMPSHIRE,

Cautions Manufacturers against infringement of Orange Spoon Bowl, as shown in accompanying cut, as it is fully protected by Letters-Patent.



MANUFACTURER OF FINEST LINE OF ORANGE SPOONS ON THE MARKET.

BY SPECIAL ARRANGEMENT, CERTAIN PROPRIETORS OF SOUVENIR SPOONS ARE PERMITTED TO USE THIS BOWL.

MAKER OF PAUL REVERE, NEW HAMPSHIRE AND PRISCILLA SOUVENIR SPOONS.



Nickel-plating Zinc.—A process for nickel-plating zinc is described in a European chemical paper. The zinc is cleaned by dilute hydrochloric acid and thoroughly washed. It is then hung in the nickel bath for a short time, and on taking out is rinsed and thoroughly scraped, so removing all that does not adhere firmly. This is repeated till the zinc is covered with a thick film of nickel, which can afterward be made as thick as required. The suitable current strength is easily found. When the zinc is once thoroughly covered, the current may be increased without any risk of peeling off. Another process is described by the correspondent of a German contemporary. He says it can be successfully and easily accomplished by first dipping the zinc in mercury. A fine plating of the nickel can then be secured on the zinc, even with a feeble galvanic current, durable and susceptible to the highest polish.

Anti-oxidizer.—The following is a valuable formula for making an anti-oxidizer for hard soldering, which saves much hard work, the necessity for scouring and rubbing, and an endless amount of polishing afterward: Take five grains of muriate of ammonia, one ounce of soda borax and one ounce of boracic acid. Dissolve in a small portion of rain water (warm) and keep in a glass bottle. Apply preparation to the article to be soldered with a piece of pegwood. Put the fluid all over the article and use any good hard solder. When your solder has flowed under dip the article in the cup of pickle. A little brushing, and then it is as bright as ever.

Waxed Paper.—Paper saturated with wax, paraffine, or stearine is very useful for wrapping up articles which should be kept dry and not exposed to the air. Place a sheet of stout paper on a heated iron plate, and over this place the sheets of unglazed paper—tissue paper does very well—that are to be waxed. Enclose the wax or paraffine in a piece of muslin and as it melts spread it evenly on the paper.

The Division of Troy Weight.—The term "troy" was first applied to the standard pound in 1495. The Troy pound contains 12 ounces, each ounce 20 pennyweights, and each pennyweight 24 grains; standard gold is compounded of 449 grains of fine gold and 40 grains of alloy to the ounce. The troy pound contains 5,760 grains, and is to the avoirdupois pound as 144:175; while the troy ounce is to the avoirdupois ounce as 192:175. *Assay weight:* The weight of gold is a pound, which is divided into 12 ounces, each ounce into 24 karats, each karat into 4 grains, and, lastly, each grain into 4 quarters, thus the assay quarter grain is in reality 1/2 grain Troy.

Art Work from Corn Stalk.

CORN and corn stalks have been in existence probably as long as man himself but it was not until a few years ago that one man with imagination and invention looked at the pith of the corn stalk and saw in his mind's eye the possibility of its being made into beautiful works of art. The sequel to that idea can now be seen in the stores of Greenleaf & Crosby, Jacksonville and St. Augustine, Fla., in the form of beautiful vases, bowls, urns, pitchers, panels, picture frames, jewel caskets, etc.

The process of the manufacture of this ware, is, of course, not given to the public in its entirety and some of the implements employed are patented. The pith is kiln-dried until the moisture is entirely extracted. It is then cut into transverse or longitudinal discs, squares or rhombs and these are carefully fitted over a mould of any desired shape and designed into various geometric mosaics, all the pieces being so carefully joined together that it requires a strong light to reveal the joints of the smooth, unbroken surface which is presented.

This surface is in some instances delicately marked, the satiny texture of the pith showing through and looking like the delicate bloom on the surface of a ripe plum. Other

articles are coated with minute fragments of pith, finely chopped by transverse knives; they have the appearance of being covered with delicate frosting, like that seen on silver; some surfaces are rough and are tinted in colors.

Over the background as described, is laid the ornamentation, the fancy of the artist here finding full play; sprays of roses, brambles, star-like daisies, discs of various sizes, scrolls and graceful arabesques, forming geometric patterns, are laid on so deftly that the whole seems skilfully carved out of a solid piece of material. The sprays of flowers are in their natural colors and the background shows sometimes the natural tint, or a soft pigeon egg blue, delicate olive, or pink; indeed the invention of the designer seems inexhaustible in producing novel and charming effects, his fancy even extending to real pictures, partly in relief, partly in color, as seen in the absolutely faithful representation on a large panel, of the famous city gates of St. Augustine, with a daisy strewn mat and frame.

This production is called zeopitha work and is the invention and work of one man, Mr. Hoyt, with Greenleaf & Crosby. His entire time is devoted to it, and all the articles he can make are readily disposed of

FACTORY,
ST. IMIER SUISSE.

HIPP DIDISHEIM,

83 NASSAU STREET,
NEW YORK.

IMPORTER OF WATCHES,

SPECIALTIES:

The "*Nassau*" the best imported movement in the market, fitting all American cases.
The "*Mignon*," the best Chatelaine Watch for the money.
The "*Gem*," a high grade Chatelaine Watch with second hand, gold crown jewels in extra settings, etc.

If your jobber don't keep these goods, send to us and we will send you the address of one who does.

Geneva Optical Co.,
MANUFACTURERS OF
Spectacles, Eye
Glasses, Lenses
and Cases.
23 WASHINGTON ST.,
CHICAGO.



The Highest Grade
— OF —
Electro Silver

Plated Ware

Is Stamped with the
 **ROGERS TRADE-MARKS.**

MANUFACTURED BY

The Wm. Rogers Manufacturing Co.,

P. O. DRAWER 30,

HARTFORD, - CONN

THE FINEST
Watch
AND
Clock
Oil
MADE.



W. F. NYE
Superfine
WATCH OIL.
New Bedford, Mass. U.S.A. NONE GENUINE WITHOUT MY SIGNATURE
W. F. NYE

W. F. NYE
Superfine
CLOCK OIL.
New Bedford, Mass. U.S.A. NONE GENUINE WITHOUT MY SIGNATURE
W. F. NYE



✻ FOR SALE. ✻

MARFELS' CELEBRATED COLLECTION OF RARE AND ANCIENT WATCHES.

THE COLLECTION COMPRISES:

EIGHTY (80) perfect specimens of Horological Art, dating in manufacture from the Sixteenth Century.

ELEVEN (11) portions of watches, cases, enamelled plates, &c., and

SEVERAL HUNDRED fine engravings of watches dating from the Sixteenth to the Eighteenth Century.

Among the Remarkable Specimens in the Collection, are:

A watch made entirely of WOOD,

A watch made entirely of IVORY,

A watch made entirely of MOTHER OF PEARL,

A watch made entirely of IRON,

A watch with a PORCELAIN CASE.

A watch in the form of a cross made in a ROCK CRYSTAL case (worn by bishops about 1550).

ALSO

*The Oldest Watch in the World with Engraved Case, from Peter Flötner,
XVI. Century.*

This collection, containing as it does perfect specimens of Horological Art from the early part of the Sixteenth Century, would make a valuable addition to a museum or exhibition.

The *entire collection* as stated above will be sold for

TWENTY-FIVE THOUSAND DOLLARS.

Some of these watches were described in THE JEWELERS' CIRCULAR for 1889, but the collection has been greatly added to since then.

Correspondence is solicited from any museum, institution or individual contemplating the purchase of this collection. For further particulars, address the owner,

CARL MARFELS,

Grosser Hasenpfad 56, - Frankfurt-on-Main, Germany,

OR THE JEWELERS' CIRCULAR PUB. CO.,

189 Broadway, New York.



CHAS. S. PLATT.

1837. Successor to George W. Platt, 1881.

GOLD AND SILVER

Refiner, Assayer and Sweep Smelter.

Office and Refinery,

29 & 31 GOLD ST., near John St., NEW YORK.

Platers' and Electro-Platers' Silver-Platinum and Aluminum.

Workshops to let, with power. Fine Light—specially for Jewelers. All improvements. Apply as above.



S. P. HOWARD,

Gold and Silver Assayer,

Refiner and Sweep Smelter,

8 & 10 JOHN STREET, NEW YORK.

Smelting and Refining Works,

28, 30 & 32 Cumberland St., Brooklyn, N. Y.

Specialties: Sweepings, Gold, Silver and Platinum.

IF YOUR JOBBER DOES NOT CARRY A FULL LINE OF "ROGERS & HAMILTON" PLATED WARE HIS STOCK IS INCOMPLETE. WRITE THE FACTORY. WATERBURY, CONN.

LOUIS NEWMAN, -Jr.

GOLD AND SILVER

Plater, Fire Gilder and Colorer.

Gilding by a New Process. Watch Cases, Jewelry and Novelties, Work stands acids, and in finish equal to Gold.

36 & 38 JOHN STREET, NEW YORK.

S. F. MYERS & CO., Wholesale Jewelers.

EVERYTHING THAT PERTAINS TO THE JEWELRY TRADE. 22 DEPARTMENTS.



WE REQUIRE AND OCCUPY THE LARGEST SALESROOMS IN OUR LINE. 4 STORES. GROUND FLOOR.

48 & 50 Maiden Lane and 33 & 35 Liberty Street, New York. CONSULT OUR MAMMOTH CATALOGUES.

L. LELONG & BRO.,

GOLD AND SILVER

Refiners, Assayers and Sweep Smelters,

◁ SOUTHWEST CORNER HALSEY AND MARSHALL STREETS, ▷

NEWARK, N. J.

SWEEPINGS A SPECIALTY.

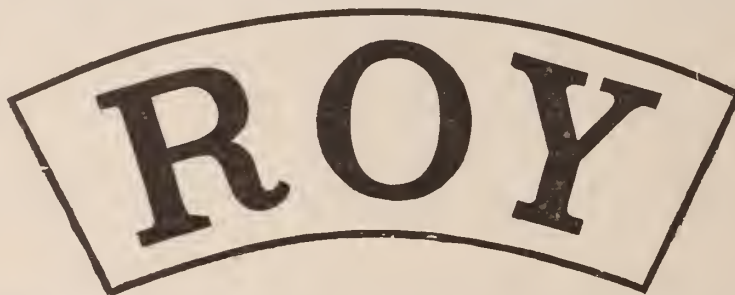

ODENHEIMER & ZIMMERN, ▷

MANUFACTURERS OF

Gold and Diamond

JEWELRY,

★ THE O. & Z. Interchangeable Initial Rings, Locketts and SLEEVE-BUTTONS. ★

Gents' Seal,

Ladies' Fancy and Children's Rings.

46 Maiden Lane, New York.

ALBERT LORSCH & CO., 37 Maiden Lane, New York.

P. O. BOX 2139.

167 Broad St. (P. O. Box 941), Providence, R. I.

IMPORTERS OF

DIAMONDS, PRECIOUS AND IMITATION STONES.

Sole owners and Importers of

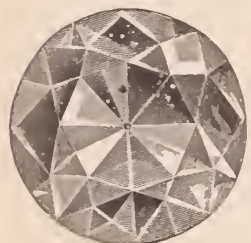

Unequaled in

The Sumatra Gem. REG'D.

Brilliancy.

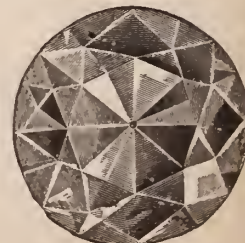

The nearest approach to the Genuine Diamond. For sale by all leading Manufacturers and Jobbers. All Jewelry set with these Stones is sold on cards stamped "The Sumatra Gem, Reg'd."

COMPARE ALL OTHER GOLD FILLED CASES WITH THE CELEBRATED CROWN LION EXCELSIOR H. MURR'S SONS HAND ENGRAVED CASES Made by EXCELSIOR

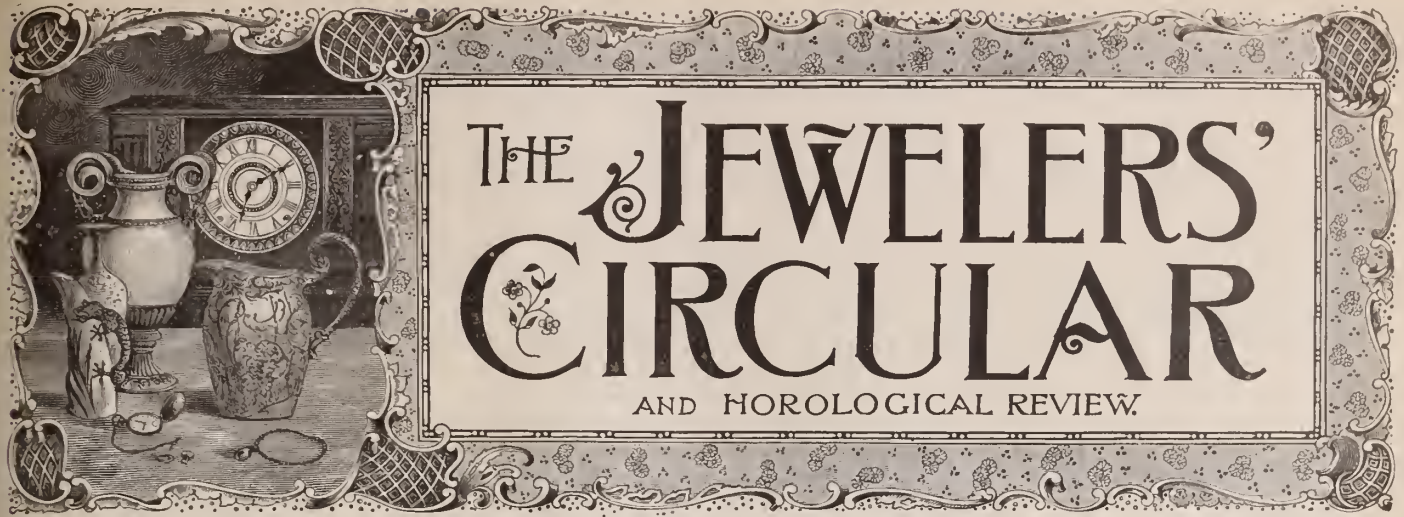

Entered at the Post Office in New York as second-class matter.

PRINCES OF AMERICAN DINERS BANQUET.



EARLY, around a festal board graced by the presence of fair ladies and illuminated with the mellow light from candelabra, partaking of viands most pleasing to the palate, and breathing in an atmosphere sweet with delicate floral per-

fumes, the Boston Jewelers' Club assembled Thursday evening, March 12, at the Hotel Vendome.

D. C. Percival, the recently-elected head of the organization, presided and covers were laid for upwards of 50 participants. Beyond Mrs. Percival at his right were C. N. Thorpe and Mr. and Mrs. J. L. Shepherd, and on his left were Mr. and Mrs. E. J. Scofield and Mr. and Mrs. J. H. Noyes. The other banqueters present were:

Mr. and Mrs. C. F. Morrill, Richard Carle, Mr. and Mrs. O. A. Drinkwater, Mr. and Mrs. M. N. Smith, Mr. and Mrs. H. W. Patterson, Mr. and Mrs. Irving Smith, J. S. Blake, secretary of the club, Mr. and Mrs. A. Paul, Mr. and Mrs. Wm. Paul, Mr. and Mrs. A. T. Sylvester, Mr. and Mrs. A. T. Morrill, Mrs. J. Lockwood, H. M. Richards, Mr. and Mrs. Charles Harwood, Miss A. M. Harwood, Miss M. Crane, Mr. and Mrs. C. A. Gilchrist, Mr. and Mrs. Thomas Long, Mr. and Mrs. E. A. Whitney, C. F. Wilson, Mr. and Mrs. W. H. N. Pratt, Mr. and Mrs. E. H. Richards, Mr. and Mrs. I. Morrison, Mr. and Mrs. Dean Southworth, Miss A.

C. Burche, Mr. H. Parker, and Miss L. Percival.

Excellent music from the Alpha Mandolin and Guitar Club helped to enliven the occasion, while the company was engrossed



D. C. PERCIVAL,
Pres. Boston Jewelers' Club.

with the menu. This was an elaborate specimen of the art preservative of arts, each card being daintily hand-painted and embossed in gold with the words, "Ladies' Night, Boston Jewelers' Club, March 12, 1891," and the name of the person at whose plate it was laid. The list of edibles was printed upon an insert of colored satin ribbon.

It was six o'clock when the reception began, and the cathedral chime clock in the parlors adjoining the elegant private dining hall of the hotel noted the passing of the hour of nine before President Percival turned the attention of his epicurean companions to the feast of reason which was set forth on another page of the menu.

His address of introduction was brief, but pithy. "It is with great pleasure," said he, "that the Boston Jewelers' Club at this, its annual ladies' night, extends a very hearty welcome to its guests. Some whose presence we should have enjoyed are unable to be here, and the secretary will read the letters of regret that he has received."

J. S. Blake thereupon produced a number of missives full of expressions of good-will, among them being letters from Treasurer R. E. Robbins, of the American Watch Co., Waltham, who is now in St. Augustine, Fla.; President M. N. Burchard, of the Chicago Jewelers' Association; M. C. Ellis, President of the Canadian Association of Jobbers in American Watches; Seth E. Thomas, of New York; Hiram Howard, of Providence, R. I.; C. J. Hayden, Treasurer of the E. Howard Watch and Clock Co.; G. E. Fahys, of New York; W. H. Fitzgerald, President of the Crescent Watch Case Co.; F. R. Appleton, of Robbins & Appleton, New York; A. M. Commelin, Treasurer of the Crescent Watch Case Co.; and last, but not least, H. F. Hahn, of Chicago, President of the National Association of Jobbers in American Watches.

The last letter evoked considerable applause. In it President Hahn said: "I share with Col. Ingersoll a high regard for Boston and Bostonians. * * * As men and merchants the jewelers of Boston stand

pre-eminent, each of whom is a prince in his sovereignty. Their manly support and the great kindness shown to me on all occasions merits my lasting gratitude."

Mr. Percival next introduced Charles F. Morrill as toastmaster. Mr. Morrill, in assuming the position, said: "Mr. President, guests and members of the Boston Jewelers' Club. Through the rather doubtful kindness of the president, I have been requested to act as toastmaster, and as a dutiful member of this club I accepted the position. I am not particularly familiar with ancient history, but it is said, I believe, that the office of toastmaster was created in ancient days of Roman feasts by a rather lazy—I should say 'habitually tired'—presiding officer, who desired to escape a disagreeable duty.

"It is also said that in certain organizations the office of toastmaster is served out as a species of punishment upon members who are delinquent in their dues (laughter). I may be over-suspicious about this matter, for I was just a little late last year in paying my dues, but after this I shall try and keep on good terms with our reasurer.

"What I have said about punishment, however, does not apply to the gentlemen whom I shall introduce to you this evening, for public speaking is no punishment to them; they are all professional after-dinner speakers and enjoy banquets and speech-making. For the first toast," continued Mr. Morrill, "I will introduce a Boston incident which will ever be remembered with pride

by the people of this great country. 'The Boston Tea Party of 1773; the only tea party on record where ladies were not present,' and to respond to this I will call upon our genial fellow-member, Eugene H. Richards."

Mr. Richards said that, after the Apollinaris and other nectars they had just enjoyed, tea and "Drinkwater" were hardly appropriate. (Laughter.) One reason why ladies were not present at the historic tea-party was because the manner of mixing was hardly to their taste. He then referred eloquently to the great service, to this city and the nation, of the Boston lovers of liberty in 1773, making the people prosperous and happy, free from the mastery of sovereigns not of their own choosing.

To the second toast, "Our Honored Guests: hospitality to them is pleasure for us," President C. N. Thorpe, of the Watch Case Manufacturers' Association, responded. He said that in thanking the Club for its splendid entertainment, he was sure he expressed the sentiments of every guest.

He told some amusing stories, paid a delicate compliment to R. E. Robbins for his display of courage, energy and determination in critical days of the watch business and praised such associations as the Jewelers' Club for the good they accomplish for the trade.

The other toasts were as follows: "The Ladies; may the dewdrops that fall from the dark clouds of care, melt away in the

bright, beaming smiles of the fair;" to which W. H. N. Platt responded; "The Power of Art; the world without art or dress would be but one vast wilderness;" J. L. Shepherd responded to this sentiment in glowing language, touching especially on the influence jewelers bear on the art of the world; his remarks were frequently applauded. "The present hour; anticipation may be good, but participation is better," responded to by A. T. Sylvester; "Prosperity to our sister associations; a hearty welcome to their representatives who have honored us with their presence," responded to by J. H. Noyes; "The Boston contingent; our guard of honor," response by Andrew Paul.

The reception committee was composed of D. C. Percival, Charles Harwood, C. F. Morrill, Irving Smith, Andrew Paul, W. H. N. Pratt. The committee of arrangements to whom the success of the affair is due was formed of Secretary J. S. Blake, Irving Smith and C. F. Morrill.

A Long Wanted Confidence Worker Jailed.

BUFFALO, N. Y., March 13.—Sergt. Geary and Special Sullivan of the Second Precinct arrested Isadore Mendell on Wednesday evening for an offence which he and other members of a gang committed in this city about six years ago. An indictment was found against him at the time.

Mendell's was a confidence scheme, worked on an unsuspecting jeweler in the following manner. One of the gang would go into a

FIGURES TALK.

6,000 PAIRS DAILY of Spectacles and Eye Glasses are sent out by the

SPENCER OPTICAL MFG. CO.

MAKING A GRAND TOTAL OF

1,800,000 PAIRS ANNUALLY.

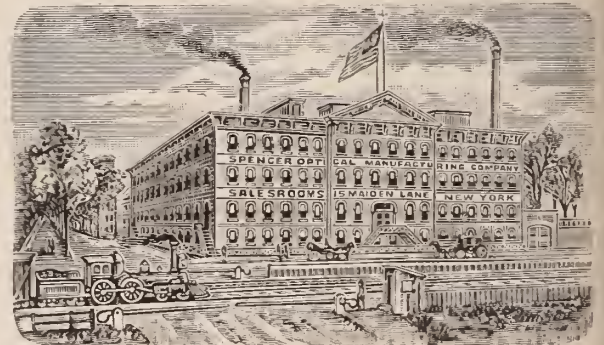

The reason is that the trade are realizing that it is to their advantage to deal directly with the manufacturers. We advertise no cut prices. All our prices are lower or as low as the lowest, when quality is considered. Our Catalogues and Price-List are free.

OPERA GLASSES

Of new designs and styles are already being prepared for the fall trade of 1891. Send in your orders and have name engraved on eye-piece. Our

OPERA GLASS HOLDERS

Are a great success, and customers are sending holders of other makes to be exchanged for our improved "grip."

A HARD CASE

To excel is the "Audemair" Occulists' Trial Case. 15 styles at 15 prices; from \$36.00 to \$100.00. You should see it before purchasing.

ANYTHING PERTAINING TO VISION

Can be obtained of us.

THE SPENCER OPTICAL MFG. COMPANY,

MANUFACTURING OPTICIANS.

15, MAIDEN LANE, N. Y.

TRADE
SEAMLESS
 MARK.
GOLD · FILLED · CHAINS.

ON ACCOUNT OF

THE great popularity of the chains made exclusively by us for the past three years, the air has been FILLED and the paper of the various Jewelers' Journals COVERED with the word "SEAMLESS" which has been and is our trade mark.

We never had such a boom in our business as we have had since our friends commenced to advertise our goods.

We have only a word to add, and that is we make and sell the

ORIGINAL AND GENUINE
SEAMLESS GOLD FILLED CHAINS.

In addition to the word SEAMLESS and for the protection of our customers we place upon each Chain a tag bearing the following trade-mark:



Which is affixed by authority of its owners, as a guarantee that the Chains are made from the Burdon Seamless Filled Wire.

<p>BOSTON OFFICE, 6 WINTER STREET, In charge of I. W. STELLE.</p>	<p>NEW YORK OFFICE, 17 Maiden Lane.</p>	<p>PACIFIC COAST AGENCY, WM. E. PETTES & Co., PHELAN BUILDING, SAN FRANCISCO, CAL.</p>
---	---	--

Address all communications to

KENT & STANLEY,
 PROVIDENCE, R. I.

jeweler's shop and ask to see some lines of jewelry. While he was carefully inspecting them, another of the gang, apparently a stranger to the first, would enter the same place and in an agitated manner relate a clear story of how he had just arrived in the city from Canada and was unable to obtain his clothing, as it was held by the customs authorities. The pal, who entered in the role of a customer, would at once enliven the conversation with sympathetic remarks and ask the alleged unfortunate if he had not some property about him that he could leave as security at the Custom House for his property.

In this way the interest of the proprietor of the store would be aroused, and finally the latest comer would produce a box containing a quantity of neatly-packed paste diamonds which he exhibited with great care to the jeweler, who seldom failed to offer to advance money on them to help him out of his difficulty with the Custom-house people. The gang secured several hundred dollars from their victims.

A number of East-side jewelers were worked here. The gang left town before their game was discovered, and though the police used every effort to trace them, they could not find anyone until Mendell was discovered by the officers at his boarding-house on the corner of Swan and Michigan Sts. He had only been in the city a few days when arrested. Mendell was at once taken to jail, pending trial in the Court of Sessions.

The Third Party Again Brings Suit.

A suit that will undoubtedly develop considerable interest to jewelers all over the country who are in the habit of purchasing diamonds from comparative strangers has just begun in the New York Supreme Court.

Early in June, last year, a man who gave the name of H. K. Merwin entered the store of Tiffany & Co., Union Square, New York, and to salesman W. H. Stodard who waited on him asked if the firm would buy a pair of diamond earrings that some years ago had been purchased from Tiffany & Co. He stated that he did not have the stones with him, but at the suggestion of Mr. Stodard said that he would bring them, or send them by a friend within a few days. A few days after one Tunison called at the establishment and exhibiting a pair of earrings said they were the diamonds that Merwin had spoken of. Mr. Stodard, on behalf of Tiffany & Co., offered him \$375 for the earrings. Tunison then left them and said he would call on the following Monday.

On the day named, June 9, Merwin called and said he had agreed to meet Tunison there. He waited half an hour, and then saying that the price offered him for the diamonds was satisfactory, was given the money. The same afternoon Tunison entered the place, and saying that he had been detained during the morning, asked if Merwin had been there. Being answered in the affirmative and told that Merwin had received

the money, Tunison said he guessed it was all right and left.

Now comes the strange part of the story. Some days after, Tunison made his appearance with a man whom he introduced as a Mr. Souther. The latter claimed that he was the owner of the diamonds, or had advanced money on them, and that the money for which they had been sold rightfully belonged to him. Manager R. H. Hyde was called, and to him Souther stated that Merwin had called at his store the day previous, and he thought that, not finding him, he had been tempted and absconded with the cash.

Tiffany & Co. declined to recognize Souther in the transaction, and he has now begun a suit against the firm in the Supreme Court, to recover \$440, which he claims is the value of the earrings. Tunison and Merwin cannot be found, and an application which was made by the defendants last week to examine Mr. Souther as to their whereabouts, was declined by Judge Beach. The outcome of this curious suit will be watched with interest.

Council Bluffs Jewelers are Indignant.

COUNCIL BLUFFS, Ia., March 12.—For some time past the jewelers in the city have been employing a scheme of giving prize watches to subscribers to increase trade. Nearly all the dealers of the city have at one time or another used some such scheme as this, but lately the fact was brought to their attention

ESTABLISHED 1841.

CARTER, SLOAN & CO.

MANUFACTURERS OF

FINE JEWELRY,

15 MAIDEN LANE, NEW YORK.

A. CARTER, JR.
A. K. SLOAN.
C. E. HASTINGS.
GEO. R. HOWE,
WM. T. CARTER.



Factory, NEWARK, N. J.

THE

PAIRPOINT MFG. CO.,

New Bedford, Mass.

FINE

GOLD AND SILVER PLATED WARE.

OUR LARGE LINE
OF
STAPLES
AND
NOVELTIES

WILL BEAR INSPECTION.

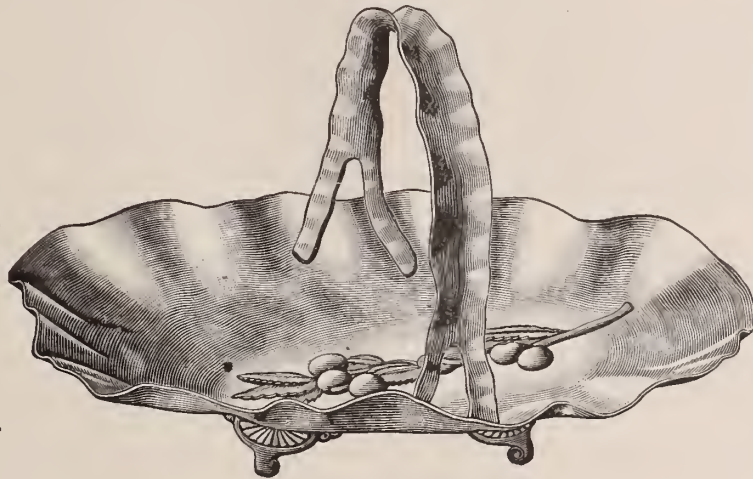

No. 1250. CAKE BASKET.

Quality
Guaranteed.

NEW YORK.

CHICAGO.

SAN FRANCISCO.

FOR CLEANING AND POLISHING.

THE LATEST AND THE BEST
POLISH
FOR
SILVER, GOLD, NICKEL
AND GLASS.



WILL NOT SCRATCH
THE
FINEST SURFACE.

EVERY RETAILER OUGHT TO HAVE IT IN STOCK.

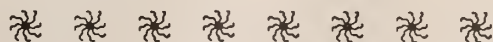

DAVID F. CONOVER & CO.

PHILADELPHIA,



PENN.

that such schemes were in defiance of the lottery law, and all the dealers in the city except one have desisted from the practice.

It was understood at the time of the notification that all would stop, and those who have observed the notice are naturally inclined to be angry over the fact that one of their number has paid no attention to the warning, and is still employing a prize watch scheme. The indignant jewelers announce that they will wait a few days, and will then prosecute the offender if he does not give up his practice.

Pilfered Uncle Sam's Jewels.

BALTIMORE, Md., March 11.—On last Wednesday night, about half past nine, Officer Conway, while on Baltimore St. near the bridge, noticed a rather neat-looking young man offering for sale a pearl bracelet and a pair of earrings of similar material. He offered to sell the lot for \$2.50, but the offer was declined. The articles appeared so attractive that the officer declined to allow him to go further, and placed him under arrest. Justice Hobbs held him for a further hearing on Thursday morning, and Marshal Frey sent out several letters asking for information. One of them went to Chief of Police Major Moore, of Washington, who kept the case in mind.

Yesterday Justice Hobbs received information that some persons had raided the National Museum at Washington, and carried

off a pair of pearl bracelets and earrings, answering the description of those recovered. They were valued at \$100, and had been loaned to the United States Government by Tiffany & Co., New York, to fill out their large collection of pearls now on exhibition at the museum. These pearls came from all over the world, and were in a conical-shaped case. Nearby is the famous Grant collection of relics and presents, but this was undisturbed. From the police information it appears that a small lock was forced open and the pearl jewelry removed from the casing.

The Washington authorities notified Marshal Frey that the articles belonged to them, and yesterday afternoon Detective S. J. Block came over with the empty cases. The man under arrest gave the name of George W. Martin, and was brought out of jail by Captain Farnan in the afternoon. He is tall in stature, well built, and consented to return to Washington with the detective. He was accordingly turned over by Justice Hobbs, and left on the four o'clock train.

The Danish Trade-Mark Law.

WASHINGTON, D. C., March 12.—The U. S. Patent Office have just issued a re-print of the Danish Trade-Mark Law, translated and forwarded for publication by Wm. P. Thompson & Co., Liverpool and London, Eng. The decree is of April 11, 1890. Article 14 says in reference to foreign patentees:

Where reciprocity is granted, it can be allowed by royal decree that the provisions of the above law shall

apply to those who carry on any of the businesses enumerated in Art. 1 outside of the kingdom. In this case the paragraphs of the law, observing the following conditions, come into application as regards the trade-marks to be registered.

1st. The application must be accompanied by a proof wherein it is shown that the applicant has fulfilled all the requisite conditions for obtaining protection of the trade-mark in his respective foreign state.

2d. The applicant shall accept the marine and commercial court here as deciding authority in all matters relating to trade-marks in question, and shall nominate in addition an attorney resident within the kingdom who can appear for him.

3d. The trade marks will not be granted to a greater extent or protected for a longer time than they are in their respective foreign states.

Article I. is as follows:

Article 1. Any person who carries on within the kingdom manufactures, agriculture, mining, commerce or industry, can, in addition to the rights belonging to him of using his firm-name or the name of any property belonging to him as trade-marks, obtain the right by means of registration in accordance with this law, to distinguish his goods from others by a different trade-mark. This right shall embrace all kinds of his goods unless it shall have been restricted to special classes on registration. The marks are to be placed on the goods themselves or on their coverings (wrappers, case, etc).

A Well-known Pennyweighter is Sentenced.

MONTREAL, P. Q., March 13.—Nellie Hayes, alias Nellie Carr, who with W. T. Hayes was arrested last fall for stealing a diamond ring from Birks & Co., 235 St. James St., this city, was tried to-day and found guilty. She was sentenced to seven years in the penitentiary.

Sentence was suspended over Hayes until

The R. Wallace & Sons Mfg. Co.,



No. 230 CUP. IN STERLING SILVER, TWO-THIRDS SIZE.

MANUFACTURERS OF

Sterling Silver, Plated Ware & Fine Cutlery

FACTORIES, WALLINGFORD, CONN.

{ New York Store: 3 Park Place.
Chicago Store: 104 State Street.

the arrival of his father who was summoned by a telegram addressed "Peoria, Ill.," and signed "S. W. H. Beauregard." Nellie Carr is 32 years old and was born in Brooklyn, N. Y. The record of the pair is well-known in all American cities.

The Meriden Britannia Co.'s Head Book-keeper Expires.

NEW HAVEN, Conn., March 13.—The Meriden Britannia Company loses a trusted and much valued employee, in the death of Edgar C. Savage, who died on Tuesday. The Company closed their Meriden office and show room yesterday during the funeral. Mrs. H. C. Wilcox sent a magnificent floral piece; Rogers, Smith & Co. another equally beautiful piece; the Britannia Company's employees, a lovely array of cut flowers; Secretary Mr. and Mrs. Geo. H. Wilcox, of the Britannia Co., an elegant wreath of roses and carnations; Mr. and Mrs. Geo. R. Curtis, of the same company, another fine floral piece.

From the Home Club, the leading social club of Meriden, of which deceased was one of the founders and most popular members, a magnificent floral golden gate; and St. Elmo Commandery, Knights Templars, a fine cross; there were about twenty other floral tributes.

Deceased had been for thirteen years the head bookkeeper of the Britannia Co., and was held by the company in high esteem. He was a graduate of Sheffield Scientific School,

Yale. The funeral procession was headed by St. Elmo Commandery and the military band. The employees of the Britannia Co.'s office and show room attended in a body.

More Suits in the McBride & Marcellus Failure.

CLEVELAND, O., March 13.—Joseph Pinkett has instituted suit in the Court of Common Pleas against D. H. McBride and C. E. Marcellus for a \$4,000 note made June 3, 1889, payable in one year.

Pinkett makes affidavit to an attachment that Mr. Marcellus conceals property or a part thereof out of the jurisdiction of the court. Orders of attachment were issued to this and Erie counties.

The hearing of the McBride-Marcellus matter has been finished.

Diamond Cutter Reinhardt Demented.

BROOKLYN, N. Y., March 11.—A man was found wandering aimlessly about near the corner of Bushwick and Myrtle Aves., yesterday afternoon. He seemed demented and was taken to the Stagg St. police station, where he was later identified as Christopher Reinhardt, an expert diamond cutter, living at 278 Evergreen Ave. He had been missed from his home since morning, and his mental condition was a surprise to his friends. He was sent before the physicians of the Charities Department this morning for examination as to his sanity.

A. WITTNAUER,

30 Maiden Lane, New York,

MAKER OF

COMPLICATED * WATCHES.

TIMING WATCHES
OF ALL STYLES.



SPLIT SECONDS
AND
Minute Repeaters.

VARIOUS GRADES, ALL ACCURATELY MADE.

Also Sole Agent for the Celebrated LONGINES & AGASSIZ Watches.

CROSS & BEGUELIN

21 Maiden Lane, N. Y.

IMPORTERS OF

SWISS WATCHES,

ALL GRADES,

From the lowest to the highest priced.

DIAMONDS,

Watch Material, Opera Glasses.

JOBBER'S OF ALL GRADES OF

AMERICAN ♦ WATCHES,

Gold and Rolled Plate Jewelry.

We carry a large stock and can supply you with any goods a Watch Dealer needs. Next time you want anything in our line, give us a trial. Orders filled same day as received.

SELECTION PACKAGE SENT ON SATISFACTORY REFERENCE.

SEND FOR PRICE LIST.

NOTICE.

The undersigned having purchased the interest of Mr. GEORGE OWEN in the firm of G. & S. OWEN & Co., have this day formed a new co-partnership under the firm name of SNOW & WESTCOTT, for the purpose of continuing the business heretofore carried on by the late firm of G. & S. OWEN & Co.

JAMES P. SNOW,
CHARLES E. WESTCOTT.

March 2, 1891.

A Septuagenarian Jeweler Missing.

MINNEAPOLIS, Minn., March 11.—Henry Adams, who had a little store at 2405 Central Ave., has disappeared under distressing circumstances. There is not any suspicion that he has gone away to defraud his creditors.

About two weeks ago Mr. Adams came to this place, and leased the store mentioned. He had but a very small stock. He proposed to do repairing. He had in his possession about \$500 worth of watches and rings which he had taken to repair. This property Mr. Adams would take home with him each night. Monday afternoon he complained of feeling ill, and left the store. That was the

last seen of him there. He took his jewelry case with him, and that is the last seen of him in that section.

The missing man is seventy-two years of age. He has three sons in Minneapolis who have made every effort to find their father. They have sent inquiries to Dubuque and other places in Iowa where Mr. Adams has either lived or visited, but have thus far been unable to get any information. He lived alone in New Boston, near here, but just where the sons are not certain. They fear that he is ill or that he has been foully dealt with, because of the jewelry he had with him.

Young Duncan's Plunder found in an Old Sock.

The diamonds valued at \$30,000 which were entrusted to William C. Duncan, a young clerk, by his employers, Lewisohn & Co., of 41 Maiden Lane, New York, on January 16, and were believed to have been taken from the city by him, have been found and are in the safe of the property clerk at Police Headquarters, 300 Mulberry St.

From facts that have transpired it appears that between one o'clock and two o'clock on the afternoon of the day before Duncan disappeared, a young man registered at the Astor House as E. Valdez, St. Louis. He had a bundle with him and he was given room 224 on the fourth floor. He asked the bell boy for a small box, and after remaining in his room about two hours he went down to the office where he passed the box to the clerk, asking him to place it in the safe until he returned. He has not been seen at the hotel since. The day following it is surmised he left the city for Havana.

About a week ago more space being required in the safe, clerk Smith suggested to Manager Keith that it be cleaned out. Duncan's box was in the outside row in one compartment. The string had become untied and at the suggestion of manager Keith, Mr. Smith opened the box. The first thing seen was an old sock under which were a lot of small diamond packages, resting on several memorandum books which proved the property to be that of Lewisohn & Co.

The following Monday Inspector Byrnes was notified of the discovery and last Wednesday Theodore Lexow, of Lewisohn & Co., was sent for. He identified the diamonds as the firm's property.

Duncan had \$1,400 with him when he went away. About \$2,000 worth of diamonds are still missing and it is said he sold them to two dealers for \$1,400.

Manager Lexow when seen by a CIRCULAR reporter, said that he supposed he would have to prove his property in court before he again gained possession of it, but that he did not anticipate any trouble in that direction.

The Otay Watch Factory to Move to San Jose.

SAN JOSE, Cal., March 12.—Superintendent Wheeler says that it is now a settled fact that the Otay watch factory will be removed here, the necessary amount of stock having been taken. It is probable that the site will be selected to-day. When the location has been decided upon, the work of removal will be commenced at once, and it will be but a short time before San Jose-made watches will be seen in the stores of the country.

The watches made by this company are considered excellent time keepers, and the company guarantee their railroad watches not to vary two seconds in a month. The industry will be a big thing for Santa Clara county.

SEE OUR INDUCEMENTS TO NEW SUBSCRIBERS ON PAGE 45.

In last week's CIRCULAR we advertised that at the completion of our annual inventory we found we had too many of certain lines of goods, wished to discontinue others, etc., and consequently had prepared a printed list of these items in the Watch, Spectacle, Tool and Material departments on which we put prices from ten to seventy-five per cent. below the regular. The demand for these lists and the orders for the reduced goods has been far beyond our expectations, and buyers have ordered a second and third time after receiving the first invoice. This annual clearance sale offers some very unusual bargains: should you not share in them? A postal card costs a penny.

Bowman & Musser,

Importers and Jobbers,

Watches, Chains, Spectacles, Tools and Materials,
Lancaster, Pa.

HAYDEN W. WHEELER & CO.,

2 MAIDEN LANE, NEW YORK,

Have an unusually large and varied stock of

FANCY STONE RINGS,

CONSISTING OF

MOONSTONE, GARNET, TOPAZ, AMETHYST, PERIDOT,

PEARL, DOUBLET, SARDONYX,

And the various combinations of these Stones.

DIAMONDS, ♦ WATCHES, ♦ JEWELRY.



Glyptological Art Applied to Gems.

PHILADELPHIA, Pa., March 11.—Maxwell Sommerville yesterday afternoon delivered a lecture under the auspices of the University Lecture Association, on "Glyptology." The lecturer has been for many years a collector of engraved gems and rare talismanic stones, and his collection, which he has presented to the University Museum of Archæology, and which he is now engaged in arranging, is probably the most complete of the kind that has been made by any private individual.

The lecturer was introduced by Provost Pepper, who said that glyptology was a good dictionary word, and was now generally accepted as a scientific term. He said that during the past summer he had himself been an agent in the purchase of priceless specimens which had been acquired for the University Museum by the liberality and discriminating taste of Mr. Sommerville.

Mr. Sommerville expressed the hope that his special taste, namely the collection of gems and talismans, might be of value to the student of ancient art and archæology. He then spoke of the peculiar importance of gems, talismans, etc., as aids to historical study, on account of their indestructibility. While temples and shrines, statues and obelisks moulder away, leaving only fragmentary and often illegible inscriptions to posterity, these gems remain perfect and keep the records that have been entrusted to them as clearly as on the day on which the artist chiselled them.

The lecturer then spoke of the preference which glyptic artists showed for spotted stones, because they could use these to give variety and picturesqueness to the figures which they engraved. Thus in a gem representing the death of Socrates, which is contained in Mr. Sommerville's collection, the bowl of poison is cut on a red spot in the stone. In the same way these variations of colors were used to bring out diadems, royal robes, etc. In following lectures Mr. Sommerville will speak of the mythological meaning of talismans.

Preferred Death to Marriage.

PITTSBURGH, Pa., March 11th.—Jacob Schneider, a jeweler of Allegheny, this morning light-heartedly called at the house of George Lang to claim the latter's daughter Tillie as his bride. His grief may be imagined when he learned that the young woman had just died from a dose of poison she had taken last night.

She had for some time been in poor health, and yesterday had a quarrel with her lover. They were to have been married two months ago, but the ceremony was postponed and was to have taken place to-day, all the arrangements being completed and the guests bidden.

The girl had evidently poisoned herself rather than wed.

Boston, Mass., March 4, 1891.

Enclosed you will find two dollars for my subscription to your valuable paper. I think it improves every year.

Geo. S. Melville.

ESTABLISHED 50 YEARS.

RANDEL, BAREMORE & BILLINGS,

IMPORTERS OF

DIAMONDS,

AND OTHER PRECIOUS STONES.

FINE PEARLS A SPECIALTY.

MANUFACTURERS OF

DIAMOND JEWELRY,

IN THE LATEST DESIGNS.

Diamonds Recut in Modern Styles or Repaired on Premises.

58 Nassau Street,
29 Maiden Lane,
NEW YORK.

1 Tulp Straat,
AMSTERDAM.

1 St. Andrews St.,
Holborn Circus,
LONDON, E. C.

ORIGINAL

GOOD FRIDAY NOVELTIES,

IN
STERLING SILVER.

FRANK H. LA PIERRE,

No. 18 EAST 14th STREET, NEW YORK.

T. B. BYNNER,
Dealer in

Diamonds, Opals, Pearls,
AND EVERY VARIETY OF PRECIOUS STONES,
in varied and novel combinations.
177 BROADWAY, NEW YORK.

LOUIS NEWMAN, JR.

GOLD AND SILVER
Plater, Fire Gilder and Colorer.

Gilding by a New Process. Watch Cases, Jewelry and
Novelties, Work stands acids, and in finish equal to Gold.
36 & 38 JOHN STREET, NEW YORK.

FACTORY,
ST. IMIER SUISSE.

HIPP DIDISHEIM,

83 NASSAU STREET
NEW YORK.

IMPORTER OF WATCHES,

SPECIALTIES:

The "Nassau" the best imported movement in the market, fitting all American cases

The "Mignon," the best Chatelaine Watch for the money.

The "Gem," a high grade Chatelaine Watch with second hand, gold crown jewels in extra settings, etc.

If your jobber don't keep these goods, send to us and we will send you the address of one who does.

Ludwig Rosen

18 JOHN ST. NEW YORK.

Moore & Horton

MOORE & HORTON,
MANUFACTURERS OF
SOLID GOLD JEWELRY,
No. 11 Maiden Lane, New York.
Fine Imitation Diamond Goods a Specialty.
Selection Packages sent on Application.

ALVIN MFG. CO.,
Silversmiths,
860 Broadway, New York,
206 Kearney St., San Francisco,

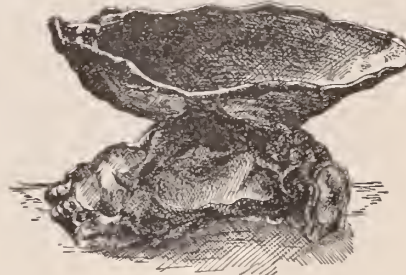

DESIGN—OYSTER SHELL—SALT.
MADE IN LARGER SIZES FOR ASH
TRAYS, &c.
Design Patented.

ALEX. WIEDERHOLD,
20 MAIDEN LANE, N. Y.,
REPAIRING JEWELER.

Jobbing sent to me by mail or express will be repaired and returned promptly. Prices Moderate and First-class Workmanship Guaranteed

"THIS RING, WHOSE HIGH RESPECT AND RICH VALIDITY
DID LACK A PARALLEL."—SHAKESPEARE.

HILDRETH MANUFACTURING COMPANY,
53 MAIDEN LANE, NEW YORK.

PLAIN SOLID GOLD RINGS AT LOWER PRICES THAN YOU
ARE PAYING. SEND FOR SAMPLES. QUALITY GUARANTEED.

KENDRICK & DAVIS,
LEBANON, N. H.

MANUFACTURERS OF THE

Standard Dust Proof Watch Key.



After this date all Keys of this Style will have number
stamped on each Key.

FOR SALE BY THE TRADE.

**Quarterly Imports and Exports—American
Commerce.**

WASHINGTON, D. C., March 11.—To-day the quarterly report of the chief of the Bureau of Statistics relative to the imports, exports, immigration and navigation of the United States for the three months ending September 30, 1890, was issued. From the mass of figures, the following items are gleaned:

IMPORTS OF FOREIGN MERCHANDISE.

	Quarter ending Sept. 30, 1890.	Quarter ending Sept. 30, 1889.
Diamonds, rough or uncut, including glaziers' diamonds	124,123	23,194
Clocks, and parts of	159,675	132,539
Watches, and parts of, and watch materials and movements	506,176	413,972
Jewelry, and manufactures of gold and silver	507,612	369,712
Precious stones, and imitations of, not set	5,240,048	3,729,710
Bronze manufactures	223,570	215,380

EXPORTS OF DOMESTIC MERCHANDISE.

	Quarter Ending Sept. 30, 1890.	Quarter Ending Sept. 30, 1889.
Clocks and parts of	308,285	320,211
Watches and parts of	76,125	55,951
Jewelry and manufactures of gold and silver	174,475	124,738
Plated ware	110,436	115,391

EXPORTS OF FOREIGN MERCHANDISE.

	Quarter Ending Sept. 30, 1890.	Quarter Ending Sept. 30, 1889.
Clocks and parts of	11	70
Watches and parts of, and watch materials and movements	250	832
Jewelry and manufactures of gold and silver	1,547	1,790
Precious stones, and imitations of, not set	4,698	

The volume also contains statements showing the imports from, and exports to American countries, for the year ending June 30, 1890. The following items are gleaned relative to the jewelry trade.

Mexico.—Imports from, clocks and parts of, \$100; watches and parts of, etc., \$449; jewelry and manufactures of gold and silver, \$2,764; precious stones, imitations of, not set, \$57,614. Domestic exports to, clocks and parts of, \$19,177; watches and parts of, \$4,945; jewelry and manufactures of gold and silver, \$19,754; plated ware, \$7,666.

British Honduras.—Imports from, jewelry and manufactures of gold and silver, \$8.

Guatemala.—No record.

Nicaragua.—Imports from, clocks and parts of, \$50.

Costa Rica.—No record.

Salvador.—No record.

Honduras.—Imports from, clocks and watches and parts of, \$30; jewelry and manufactures of gold and silver, \$120; precious stones, etc., \$30.

Cuba.—Imports from, clocks and watches and parts of, \$25; jewelry, etc., \$107; precious stones, etc., \$7. Domestic exports to, clocks and watches, 17,669; jewelry, etc., \$4,676; plated ware, 11,801.

British West Indies.—Imports from, clocks and watches and parts of, \$30; jewelry, etc., \$104. Domestic exports to, clocks and watches, \$5,137; jewelry, etc., \$4,114; plated ware, \$3,011.

Haiti.—No record.

Porto Rico.—Domestic exports to, clocks and parts of, \$2,816; watches and parts of \$9; jewelry, etc., \$10,106; plated ware, \$3,561.

San Domingo.—No record.

French West Indies.—No record.

Danish West Indies.—No record.

Dutch West Indies.—No record.

Brazil.—Imports from, diamonds, rough and uncut and glaziers' diamonds, \$3,833; jewelry, etc., \$18; clocks and watches and parts, \$40. Domestic exports to, clocks and watches, \$67,124.

Venezuela.—Imports from, jewelry etc., \$10. Domestic exports to, jewelry etc., \$43,499.

Argentine.—Domestic exports to, plated ware, \$72,370.

British Guiana.—No record.

Dutch Guiana.—Imports from, clocks etc., \$80.

French Guiana.—No record.

Chili.—Domestic exports to, plated ware, \$27,508.

Columbia.—Imports from, clocks, etc., \$13; jewelry, etc., \$20.

Uruguay.—No record.

Peru.—Imports from, jewelry, etc \$500.

Ecuador.—Imports from, clocks, etc., \$25.

Bolivia.—No record.

Canada.—Imports from, clocks and parts of, \$1,207; watches and parts of etc., \$36; jewelry, etc., \$1,649; precious stones, etc., \$14,420; bronze manufactures, \$523. Domestic exports to, precious stones in the rough, \$616; diamonds, unset, or diamond dust, or bort, etc., \$45,515; chronometers and compasses for ships, \$3,907; cases for jewelry, etc., \$3,270; clocks and cases, \$95,031; clock-springs and movts. other than tower clocks, \$1,878; manufactures of gold and silver, \$27,164; electro-plated ware, etc., \$98,669; cutlery, \$1,409; jewelry, etc., \$319,133; spectacles and eye-glasses \$17,340; parts of same, unfinished, \$9,629; precious stones polished, but not set, etc., \$918; watches, \$17,221; watch cases, \$144,638; watch actions or movements, \$350,148.

Camden, N. J., continues to be afflicted with mysterious robbers. Last week two grocery stores and a shoe store were entered, but, as in the case of the robbery at jeweler Fredericks, the thieves escaped capture. The police have made several arrests, but so far have failed to connect any of the prisoners with the more prominent burglaries. William Banks and William Post, two Groverton racing men, and George Claypoole, a wild youth of good family, are the latest arrests. They have been held for trial on the charge of minor depredations, but there is little possibility, evidently, of capturing the more wanted culprits.

USE THE  **AMERICAN MAINSPRINGS**

FOR ALL KINDS OF AMERICAN WATCHES.

[FACSIMILE OF WRAPPER.]

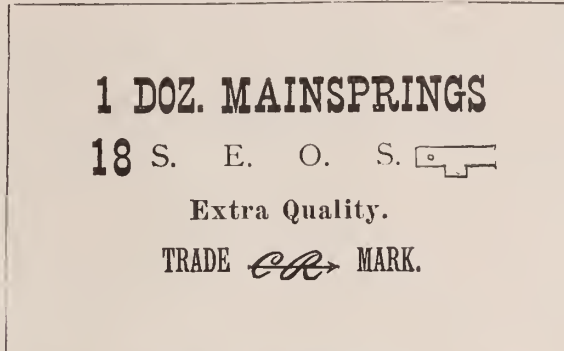

THE BEST IN THE MARKET.

L. H. KELLER & CO.,

Dealers in Fine Watch Materials and Tools.

AGENTS FOR THE PATEK, PHILIPPE & CO. WATCHES.

64 NASSAU STREET, NEW YORK.

LEWIS BROTHERS,
Easter Novelties in Silver,
41 Maiden Lane, N. Y.

ESTABLISHED 1837.
GEO. O. STREET & SONS,
MAKERS OF
Fine Rings, Locketts, Seals, Sleeve
Buttons and Links,
15 John Street, - NEW YORK.

EZRA KELLEY'S
Famous Watch, Clock and Chronometer Oils,

RECEIVED AT THE
EXHIBITION UNIVERSELLE, PARIS, 1889,

The only Award of Merit given to Manufacturers of American Oils

It is to the interest of every Watchmaker to use in his work the *Best Oil* obtainable, regardless of cost. Mr. Kelley's claim to be the foremost manufacturer of Oils, giving the best results, is not based upon his own assertion, but is founded upon the fact that wherever his Oils have been exhibited in competition with other makes, subject to an examination of experts, they have received the highest *Award of Merit*.
For sale by all the Leading Jobbing Houses.

HENRY GINNEL & CO.,

GRIMSHAW & BAXTER, EUROPEAN AGENTS,
35 GOSWELL ROAD, LONDON, ENGLAND.

GENERAL AGENTS,
31 Maiden Lane, NEW YORK

BEST and CHEAPEST DEVICE FOR MAILING

All Mailable Matter at Cheap Postage.

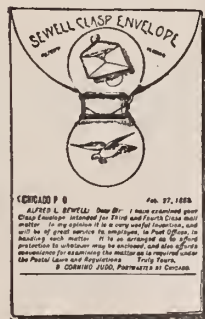

For mailing Trade Catalogues, Samples, Parcels of DRY GOODS, WOOL, YARN, COTTON, SEEDS, GROCERIES, PHOTOGRAPHS, DRUGS, WHEAT, FLOUR, GLOVES, LACES, RIBBONS, CALENDARS, SAMPLE CARDS, and all other 3rd and 4th class mail matter, is

SEWELL'S PATENT ENVELOPE CLASP,
(Patented in America and Europe.)

WHICH FITS ON ANY ENVELOPE IN THE MARKET.

In a moment it turns any envelope into a CLASP ENVELOPE. It is made of tough sheet brass. Anybody can put it on, as it is most convenient, and adjusts itself to a package of any size or thickness. It is endorsed by Postmasters.

We also make Envelopes, all sizes and kinds.
SAVE MONEY, and GET THE BEST, by writing for samples and prices to the

CHICAGO ENVELOPE CLASP CO.,
210 South Water St., CHICAGO, ILL., U. S. A.

ENVELOPES

FOR JEWELERS' AND OTHER TRADE CATALOGUES.

MAKERS OF **M. ZINEMAN & BRO.,**
"DIAMANTA" SPECTACLES & EYE-GLASSES

130 SO. NINTH STREET, PHILA., PA.

AMERICAN AGENTS FOR

MUELLER'S · ARTIFICIAL · HUMAN · EYES,

IMPORTERS OF ALL KINDS

Opera Glasses and Field Glasses,
 FOLDING POCKET OPERA GLASSES.

Sets of Trial Lenses from \$10.00 to \$75.00

» A SET. «

IMPROVED PERFECTION TRIAL FRAME.

Send for Catalogue and Price List.

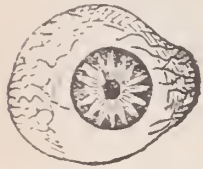

GENTLEMEN:—I think the trade this Spring will be better than last, and, although I can turn out double the work I did then, you had better be on hand with your orders, for I expect that my sales will be very large—equal to last Fall, if not double. You see the field is constantly widening and the demand is increasing, and why? Did you ever stop to think that there are 65,000,000 people in the United States, and the per cent. of this number that use glasses is one-fifth, or 20 %, making 13,000,000 people wearing eye-glasses, and if you count the myriads in Europe and South America, why it is simply immense, and it needs cultivation. Why! Gentlemen, we ought to be able to double our business every year for the next ten years.

Yours respectfully,
 Springfield, Mass. S. F. MERRITT.

MATHEY BROS., MATHEZ & CO.

16 MAIDEN LANE, N. Y., AND BRASSUS, SWITZERLAND,

MANUFACTURERS AND IMPORTERS OF

Plain and Non-Magnetic Movements.

Complicated Watches a Specialty.

CHRONOGRAPHS,
MINUTE REPEATERS,
 AND
SPLIT SECONDS,

IN ALL GRADES AND SIZES.

SOLE AGENTS FOR

H. L. Matile, C. H. Meylan and J. J. Badollet. Watches Demagnetized.



REPEATERS



CHRONOGRAPHS.

WILLIAM B. DURGIN,

Designer and Maker of Wares in **STERLING SILVER,**

CONCORD, NEW HAMPSHIRE,

Cautions Manufacturers against infringement of Orange Spoon Bowl, as shown in accompanying cut, as it is fully protected by Letters-Patent.



MANUFACTURER OF FINEST LINE OF ORANGE SPOONS ON THE MARKET..

BY SPECIAL ARRANGEMENT, CERTAIN PROPRIETORS OF SOUVENIR SPOONS ARE PERMITTED TO USE THIS BOWL.

MAKER OF PAUL REVERE, NEW HAMPSHIRE AND PRISCILLA SOUVENIR SPOONS.

FASHIONS IN JEWELRY

A Lady's Ramble Among the Jewelers.

Corsage and boutonniere holders in silver find many patrons.

Lady equestrians are wearing studs and buttons of white enamelled gold.

One continues to see in gentlemen's chains alternate links of platinum and gold.

Repoussé and plain bright finish continues to be a favorite combination in table silver-ware.

The oblong form is now much seen in jewelry, hence Marquise rings continue popular.

A cut-glass claret jug and glasses in silver deposit mountings, furnish a handsome novelty.

Rings heavily chased and showing an unpolished stone, deep set, are much affected by men.

Coffee spoons with gold bowls have open-work handles in which appear tiny forget-me-nots.

Silver book marks and silver ornamented prayer books, appropriately etched, are out for Easter.

Very convenient for presentation are small silver sugar dishes and cream jugs, handsomely cased.

With the advent of strawberries, sugar sifters and cream ladles, in new patterns, are to the front.

Silver trays come in various forms suitable for holding the fancy chocolates, which are the fashion just now.

A new tea-set seen recently was made in low form with alternate panels of repoussé and plain bright finish.

The shell lorgnette and the gold-handled monocle find a large patronage among fashionable woman of all ages.

A unique brooch takes on the form of a silver shell, studded inside with brilliants and holding in the centre a fine large pearl.

Leather-bound prayer books, entirely overlaid with silver, in an open-work design, showing the leather underneath, are handsome.

My lady's memorandum and visiting books are leather bound, with silver or gold mountings, and may cost from five to one hundred dollars each.

A novelty in way of a powder box for the pocket is out in shape of a purse that is furnished with a small mirror, a bottle of liquid rouge and a puff.

Traveling clocks for 1891 are in bright Russian leather cases ornamented with gilt. These clocks have a black dial with gilt hands and numerals.

Numbered with Easter jewelry are the "Paques" pins consisting of the letters forming the word, united into a bar, on either end of which is a large pearl.

The wearers of spectacles and eye glasses are interested in sterling silver chatelaine holders, made for their especial accommodation in rich repoussé designs.

Buttons present splendid possibilities to the jeweler. Antique buttons are in demand to suit the period, the fashion of which the dress revives. Imported ones contain the likenesses of the beauties of the time; others are set round with pearls, while a few are encrusted with gold.

ELSIE BEE.

The Railroad Track was Jeweled.

NEW HAVEN, Ia., March 11.—The jewelry valued at \$200, stolen on Feb. 21 from the jewelry store of Bernard Tibbetts of this place, has been recovered. A few days ago, police officers at Fort Wayne, Ind., found a large quantity of goods hidden along the track of the Nickel Plate R. R. a few miles from that city. The find contained a lot of jewelry which was identified by Mr. Tibbetts as part of the property stolen from him. F. J. O'Neill and James Dempsey, aged 18 and 20 years respectively, have been arrested charged with the burglary.

SEE OUR INDUCEMENTS TO NEW SUBSCRIBERS ON PAGE 45.

IMPORTANT NOTICE.

The New Trenton Movement.

H.T.G and O. F. S. W.



(OPEN PLATE.)



(CLOSED PLATE.)

We beg to notify the trade that we have placed on the market a NEW MODEL

18-Size, Seven Jeweled, S. W. Nickel Movement,

SURPASSING ANYTHING YET MADE FOR THE PRICE, and to which we invite your attention. These movements possess several new features which offer special advantages to watchmakers. They are Quick Train, Straight Line Lever Escapement, and have Safety Centre Pinions and hard enamel Dials. The barrel can be removed without disturbing the train or stem-winding parts. They are beautifully damaskeened, well finished and attractive in appearance and are EXCELLENT TIMEKEEPERS. EVERY MOVEMENT FULLY WARRANTED.

The Best Low Priced Movement in the Market.

FOR SALE BY THE JOBBING TRADE.

Send to your jobber for a sample movement. If he does not keep them, write us and we will furnish you the names of jobbers who do.

TRENTON WATCH CO., Trenton, N. J.

JEANNOT & SHIEBLERMANUFACTURERS
OF

Fine Gold Watch Cases.

No. 20 MAIDEN LANE,
New York.Constantly on hand, 14k. and 18k. Cases
to fit any Movements in the Market.**WOOD & HUGHES,**

Sterling Silverware Manufacturers.

New York Agents for the Derby Silver Co.'s

FINE QUADRUPLED PLATED WARE.

No. 16 JOHN STREET, - NEW YORK.

206 Kearney St., San Francisco, Cal.

HASKELL & MUEGGE, Agents.

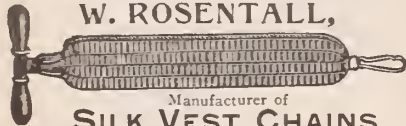
W. ROSENTALL,

Manufacturer of

SILK VEST CHAINS,

79 NASSAU STREET, NEW YORK.

Send for Selection Package with reference.

GEO. W. SHIEBLER,

SILVERSMITH.



Artistic Novelties.

HOLLOW AND FLAT WARE.

Sterling Silver

No. 8 Liberty Place,

NEW YORK.

A. J. GROENMAN & CO.,

DIAMOND CUTTERS,

80 NASSAU ST., N. Y.

WE MAKE A SPECIALTY OF SEL-
LING FINE, SMALL MELEES.**ELGIN HOROLOGICAL SCHOOL**

ELGIN, ILL.



Repiaring for the trade.

Repair price list free.

**Another Robbery in Brooklyn Exercises
the Jewelers.**

BROOKLYN, N. Y., March 14.—The window smashing thieves, who a few weeks ago, robbed the windows of Jas. H. Hart, 539 Fulton St., were apparently much encouraged by the success of their work, for on Tuesday of last week the window of W. F. Boettcher was robbed in a similar manner. The burglary was committed soon after midnight; and through a hole they made in the side of the south window they abstracted six pairs of opera glasses, valued at \$50. Shortly after 11 o'clock, the same evening, a man was seen lounging in front of Wm. Wise & Son, 239 Fulton St., but at the approach of an officer he walked away.

The jewelers of this city are considerably exercised over the various robberies that have occurred in this city during the past few weeks, and, as previously published in THE CIRCULAR, a petition has been sent to the Police Commissioners by the jewelers along Fulton St., asking that the night officers of that district be given "straight" posts.

When spoken to on the subject by a CIRCULAR reporter, P. W. Taylor, 521 Fulton St., said that he would be perfectly willing to contribute toward the support of a private watchman to cover the jewelry stores of the neighborhood, and he thought it would be a good idea for the jewelers to organize a service of that kind. A representative of Jas. H. Hart and several other jewelers who were seen, expressed similar views.

WANTED, AN ADVERTISEMENT.

I will pay Fifty Dollars in cash to the Retail Jeweler who shall prepare the best worded and most effectively displayed advertisement of *Abbott's Patent Stem-Winding Attachment*, suitable for use in Magazines and Newspapers that reach the general public.

The advertisement to occupy a space of not more than two inches high by five inches wide.

The contest will close May 1st, 1891, and the prize will be awarded within ten days from that date.

**I WILL PAY
FIFTY
DOLLARS
IN CASH**

The following gentlemen will act as judges:

Mr. L. J. MULFORD,
Of The Jewelers' Circular.

Mr. ALBERT ULMANN,
Of The Jewelers' Weekly.

Mr. JOHN L. SHEPHERD,
Of The Keystone.

Circulars and descriptive matter supplied on application.

HENRY ABBOTT,

After May 1st, 14 Maiden Lane.

4 Maiden Lane, N. Y.

**The Columbus Watch Plant will likely
be Enlarged.**

COLUMBUS, O., March 11.—The committee on manufactures of the Board of Trade, accompanied by the committee of the South-side Improvement Co., visited the Columbus Watch works yesterday afternoon. The gentlemen spent several hours at the works securing information as to their capacity, general operations, and other matters. The watch company have for some time desired to enlarge their plant, and to this end it will be necessary to increase the capital stock to at least \$150,000.

The company are now employing from 375 to 400 people, and are turning out about 200 watches per day. It is expected that the capacity of the works will be doubled if the necessary capital is secured.

The Columbus Company have received flattering proposals to move the works to other places, but they desire to remain in Columbus, if local capitalists will subscribe the necessary stock to enlarge the plant.

The members of the Board of Trade committee were very favorably impressed by their visit, and will meet on the night of March 18 to prepare a report on the matter to be placed before the people.

SEE OUR INDUCEMENTS TO NEW SUB-
SCRIBERS ON PAGE 45.

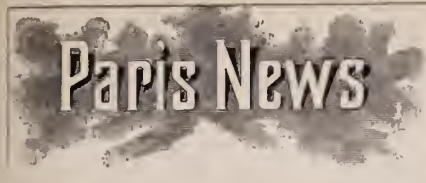

THE EFFECTS OF "THERMIDOR" ON THE JEWELRY TRADE—GLEANINGS FROM MASSIN'S RAPPORT.

PARIS, France, March 7.—The appearance on the stage of Thermidor, Sardou's new play, which gave rise to a great disturbance at the Theatre Francais, whose audiences are so quiet, as a rule, and the noisy manifestation of the Robespierrists has, as might have been expected, already influenced our trade. In the suburbs, or faubourgs of Paris, where Jacobins are numerous, jewelers who have brought to the front of their display all in the way of revolutionary jewels they had in stock such as enamelled Phygian caps, etc., are doing a good business. Artisans of rebellious inclinations are liberally treating their sweethearts to brooches which are three-colored cockades and earrings in the shape of red lanterns made of imitation stones.

On the other hand, jewelry shops that sparkle in aristocratic quarters exhibit some very fine anti-revolutionist jewels, among which tiny diamond daggers (scarf pins), with a *fleur-de-lis* forming the hilt, are conspicuous.

Several pretty bonbon-boxes, with Charlotte Corday's portrait painted in enamel on the lid, have also appeared in some of the Palais Royal show windows.

I noticed at a jeweler's, in the Avenue de l'Opera, a very simple yet very elegant set; the necklace and the bracelet consisting merely of a succession of table-cut emeralds and faceted diamonds, with a large emerald on each as a center piece.

From Massin's Rapport on jewelry, mentioned in one of my last letters, I gather the following extracts, picked out here and there from the last pages:

Handled by a skilful *joaillier*, flowers complacently obey. Dog-roses are grouped and arranged so as to answer the purpose for decorating a corsage, capricious stalks and flowers of convolvuli, made of diamonds and striated with rubies, are entwined together, then gathered circularly into a shoulder ornament.

Great liberty as to the choice of models is allowed for hair-jewelry. Among them doves' wings, the feathers of which must appear fluttering, are very difficult to execute. To make with stones a simple bow-knot looking like a real one, it often requires more talent than to turn out an elaborate fichu, admitting of fancy.

A very decorative corsage garniture consisting of colored diamonds, yellow and brown, associated with white ones, forms a piece of polychrome jewelry of a grand effect, especially if it is made to fit exactly on the bodice, branching up gracefully on both sides in the shape of a V.

N. KOCH.

L. DREYFUS.

J. KOCH.

I. PFORZHEIMER.

KOCH & DREYFUS,

22 John Street, New York.

IMPORTERS OF DIAMONDS,

JOBBER OF

AMERICAN WATCHES,

Diamond Novelties and Jewelry

We have now a complete line of Goods and Specialties on hand and on the road in charge of following representatives:

JONAS KOCH, GEO. MALLET, L. GOLDSMITH,
HENRY HEYMAN, A. ROSENTHAL.

THE LATEST PARISIAN NOVELTY.



MANUFACTURED BY
CROSSIN & TUCKER,
409 Pine Street, Providence, R. I.

BAKER & CO.,

Gold, Silver and Platinum Refiners,
ASSAYERS * AND * SWEEP * SMELTERS
408 New Jersey Railroad Avenue,
Cor. Murray Street, NEWARK, N. J.



SEE THE NEW CUTTINGS
FOR 1891,

CRESCENT

AND
OLYMPIC

The best American Cut Glass is that
manufactured by

THE PHENIX GLASS COMPANY,

OF PITTSBURGH, PA.

Unequaled in its BRILLIANCY, DEEP CUTTING and DESIGN.

729 Broadway, Cor. Waverly Place, N. Y.

43 SIXTH AVENUE, PITTSBURGH, PA.

OPPENHEIMER BROS. & VEITH, Diamonds, Watches and Jewelry,

2 Tulp Straat,

AMSTERDAM.

35 Maiden Lane,

NEW YORK.

We beg to inform the trade that we are still in a position to fill orders for

✂ DUEBER HAMPDEN WATCHES ✂

Of all grades, from stock purchased previous to the closing of the factories at Canton.

JOHN A. RILEY & SLOAN CO.,

860 BROADWAY, NEW YORK.

EASTER NOVELTIES,

INCLUDING

ROSARIES AND CRUCIFIXES IN GOLD AND SILVER.

ALSO HAIR PINS, TIARAS AND A GENERAL LINE OF GOODS
FOR LADIES' WEAR.

The "BRYANT" Initial Ring.

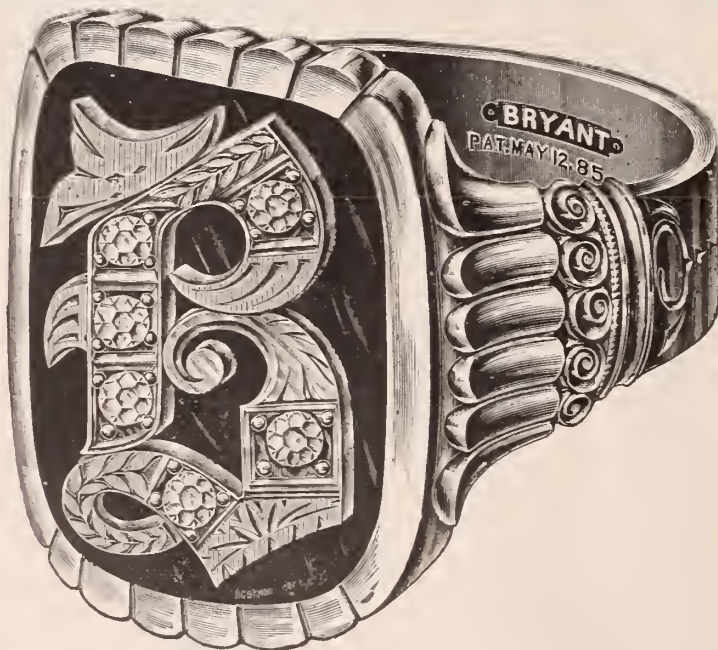

In Various Styles, Most Easily Interchangeable,
Handsome and Best.

M. B. BRYANT & CO.,

10 MAIDEN LANE, - - - NEW YORK.

News Gleanings.

J. N. Nelson, Spicer, Minn., has sold out.

C. H. Pierce, Montevideo, Minn., is dead.

J. J. Roe, Buchanan, Mich., is out of business.

August Hempel, Galveston, Tex., has given up business.

J. M. Yeatman, Cross Plains, Ala., has given up business.

Crisp & Henson have succeeded J. A. Crisp, at Jefferson, O.

L. Neuberg, West Bend, Wis., has moved to Kaukauna, same State.

W. E. Page, formerly of Auburndale, O., is now located at Toledo, O.

Rankin & Fess, Kearney, Neb., have sold out to Thompson & Caldwell.

W. E. Chamberlain has moved from Onoko, Minn., to Great Falls, Mont.

Harris Bros. have moved from New Philadelphia, O., to Niles, same State.

T. Stockburger has moved from Edwardsville, Ill., to Waterloo, same State.

Reichenecker & Co., 809 2d St., Seattle, Wash., has been closed by the sheriff.

Sullivan Bros. have moved from Devil's Lake, N. D., to West Superior, Wis.

W. E. Hunt has left Sault de St. Marie, Mich., and his present address is unknown.

W. W. Parks has moved from S. Pittsburgh, Tenn., to Franklin, same State.

C. P. Rydell, 336 Smith St., Brooklyn, N. Y., has added a circulating library to his business.

Thomson Bros. & Co. have succeeded J. J. Thomson at 149 W. Bridge St., Grand Rapids, Mich.

J. W. Bryant, Edina, Mo., whose store was recently destroyed by fire, is temporarily out of business.

Mail for the J. M. Blythe Jewelry Co., Denver, Col., should be addressed to P. O. Box 2271 instead of 1515 Larimer St.

H. H. Dobson, Mexico, N. Y., has bought out the stock of A. C. Lindsley, of that town, who retires from business April 1.

C. H. Robie, who recently sold out his business at Williamson, N. Y., to A. E. Quaife, is now located in Corry, Penn.

Leopold Gumberts, of Gumberts Bros., Evansville, Ind., has returned from New York, where he had been taking a course in optics.

William B. Durgin, the well-known silverware manufacturer, Concord, N. H., is seeking health and recreation in the island of Cuba.

A. L. Hosmer, Lockport, N. Y., whose store, on Feb. 17, was destroyed by fire, incurring a loss of about \$8,000, will probably reopen business again, but not in Lockport. The insurance of \$5,800 has all been paid in, with the exception of \$900, which Mr. Hosmer expects to receive this week. About \$600 will be realized on the sale of the damaged goods.

Owen Campbell, Old Mines, Mo. is dead.
G. A. Collins, Salem, Mass., is closing out his stock at auction.

W. Edmonds, Smethport, Pa., will shortly move to a new store.

Barger & Williams have commenced business at New Freeport, Pa.

E. B. Melchor has moved from Portland, Ore., to Los Angeles, Cal.

C. F. Reitling, Carlisle, Pa., has just installed a 4,000 lb. York safe.

J. L. Reider's store, Homer, N. Y., is being changed into a double store.

R. F. Tibbett, is about to close out his business on account of ill-health.

S. S. Gleason, Watertown, Mass., is advertising a jewelry store for sale.

M. C. Conner, Burlington, Ia., is spending a few weeks at Hot Springs, Ark.

The auction sale of the stock of Evans & Davery, Elgin, Ill., is being continued.

T. G. Burkhardt has moved from California, Mo., to Jefferson City, same State.

Mrs. G. H. McKelvey, formerly at Horton, Kan., is now located at St. Joseph, Mo.

G. V. Ruhl, watchmaker, has moved from Grafton, Md., to Cumberland, same State.

Edwin Shouf, a diamond thief, was sentenced recently at Lima, O., to three years.

The lathe with the attachments used by R. E. Olney, Mansfield, Pa., is said to have cost \$450.

Victor Glendey, who recently started a repair shop in Burlington, Ia., is laid off through illness.

The Quincy Show Case Works, Quincy, Ill., have increased their capital stock from \$50,000 to \$75,000.

The Kenosha Watch Case Co., Kenosha, Wis., have increased their capital stock from \$100,000 to \$200,000.

Prof. J. H. Caruss, optician for Greenleaf & Crosby, Jacksonville, Fla., visited St. Augustine last week.

Woodworth & Schenck, Binghamton, N. Y., have been putting in a new and elegant line of sterling silver.

F. H. Raymond has resumed charge of the watch and clock-repairing department of G. T. Wilson, Meadville, Pa.

C. W. Smith, Dubuque, Ia., is suffering from mental aberration, caused by the rupture of a blood vessel in the brain.

J. K. Nye, New Bedford, Mass., has been chosen one of the Board of Directors of the New Bedford, Yacht Club.

B. F. Creel & Bro., Central City, Ky., have failed. The concern is a small one, its rating being only between \$500 and \$1,000.

D. F. Sullivan, of Rockford, Ill., is having plans drawn for a handsome \$5,000 house to be erected on his East St., property.

Wm. F. Nye, the well-known watch and clock oil manufacturer, New Bedford, Mass., will, with his wife, start next month for

California, remaining on the Pacific coast until July. In his absence, his son, J. K. Nye, will conduct the business,

No clue has been obtained as to the identity of the thief or thieves who recently robbed W. E. Cross' store at Amsterdam, N. Y.

Max Adler, of L. Adler & Co., F. Crane, of Shafer & Douglas, and L. C. Smith, of M. B. Bryant & Co., New York, were in Dayton, O., last week.

A new jewelry store has opened up at 123 Calhoun St., Ft. Wayne, Ind., under the name of Quartz Diamond Co. They were formerly in business at Battle Creek, Mich.

L. H. Green, who has been conducting a wholesale business at 2120 Market St., Galveston, Tex., has disposed of his stock at auction and gone to Key West, Fla.

George Goldsmith, employed in the factory of the American Watch Co., Waltham, Mass., was arrested last week for the larceny of \$200, the property of the factory polo league.

The retail trade in Galveston, Tex., is somewhat influenced by the Chicago Watch and Jewelry Co., who have an office there and whose canvassers cover the entire city.

Ex-Councilman Thomas Kirby, Camden, N. J., who was convicted last November of the larceny of watches from W. R. Bennett and sentenced to one year in the State Prison, has been pardoned.

August Bruder has established himself in the recently completed Odd Fellows' Building at the corner of Wayne and Calhoun Sts., Ft. Wayne, Ind., and presents a very attractive display of goods.

Neff & Casebeer, Somerset, Pa., have added an optical department to their business. Mr. Casebeer has just returned from Cleveland, O., where he took a thorough course of instruction in optics under Dr. Julius King.

The jewelers of South Omaha, Neb., feel that they have no rights which the peddlers seem bound to respect. The city ordinance requires all peddlers to take out a license at five dollars a day, but this is not enforced.

L. A. Potts, formerly a repairer with E. H. Carpenter, Burlington, Ia., and who lately started in business in that city for himself, has disposed of his stock and gone to Memphis, Tenn., where he will open a repair shop.

It is more than likely that the Manhattan Silver Plate Co. will decide to remain in Lyons, and several Lyons business men are interested in the effort to get enough stock subscribed for them to insure its permanency as a local institution.

Egnatz Lozeinka, alias Charles Schultz, a Polander, was arrested last week charged with stealing a gold watch from J. Harris, Kingston, Pa. Officer Roche arrested him. The prisoner admitted the crime. Bail was given in the sum of \$300.

Joseph Lindauer, superintendent of clock-making department of Tiffany & Co., New York, was in Rochester, N. Y., for a few days

to place in position a new and elegant chiming clock in one of our finest mansions. His headquarters are with L. Sunderlin & Co., 20 State St., who represent the interests of his house in keeping their clocks in order in this city.

The new clock for the court house at Pottsville, Pa., furnished by the E. Howard Watch and Clock Co., was last week placed in position. The clock is illuminated and the dial is visible from nearly every part of the town, both during the day and night.

H. C. H. Lewis, of Fitchburg, Mass., is the owner of the Marquis de Lafayette's watch, which is known to be at least 115 years old. It is an open face silver watch. The cases have been worn through and soldered on the inside. The watch has not been run for twenty-five years.

The jewelry store of the estate of A. F. Burbank, corner Main and Exchange Sts., Worcester, Mass., was opened last week with an entirely new stock. The Moorish room, which is a feature of the new store and a decided novelty in its way, received much attention from the ladies.

A man entered Francis Plain's store, 25 Jackson Ave., Long Island City, N. Y., last week, and asked to be shown some watches. Mrs. Plain put two time-pieces on the counter, one of which the man grabbed and then ran out pursued by the woman, who called lustily for the police. The thief, however, succeeded in escaping.

The Waltham Screw Co., Waltham Mass., have been incorporated for the purpose of manufacturing automatic machinery. The officers are R. G. Killduff, president, L. V. Foster, treasurer, C. V. Woerd, superintendent, and E. F. Hoskin, manager. It will be at least one year before the company will be in a position to supply the trade.

Last week a bold robbery occurred at Dubuque, Ia., in the broad glare of the street lights and while crowds of people were passing. A man, whose features were concealed by a handkerchief, ran his gloved hand through the show window of Burton's pawnshop and secured about \$200 worth of gold watches and made good his escape.

The sacrifice sale of the stock of C. S. Raymond, Omaha, Neb., still continues. Toward the end of this month Mr. Raymond will move temporarily into the building on the corner of Douglas and Sixteenth Sts., where he will remain while his new store is building. The temporary quarters being very small, he has found it advisable to dispose of the greater portion of his bulkier goods.

William McDonald, 223 Columbia St., Brooklyn, N. Y., had an experience last week with a bold thief. Joseph Bennett, 25 years of age, entered his store and asked to look at some watches. They were put out on the showcase, and he grabbed a handful and ran out of the door followed by the jeweler. Officer Monarch joined in the chase, the chase lasted for several blocks, and the thief was finally captured. He was held for trial.

Frank D. Enney Goes By the Board.

SYRACUSE, N. Y., March 13.—F. D. Enney, in the White Memorial building, has failed and his store is in the control of Fred C. Eddy, cashier of the Bank of Syracuse. Mr. Enney's liabilities are variously estimated at from \$20,000 to \$23,000. Of this \$5,000 is due to his mother, \$500 to his father, \$2,000 to his uncle, James Redway, of Geddes, this State, and about \$7,000 or \$8,000 to the Bank of Syracuse. These debts represent money loaned, secured by promissory notes. He was unable to meet them upon their second maturity, and yesterday, in order to cover these obligations, he transferred his stock by bill of sale to F. C. Eddy, the latter acting for the relatives as well as for the bank. There are no assets aside from the stock, which is valued at something more than \$15,000.

Deputy Sheriff Bennett made a levy on the store on an execution in favor of George Langhorst, of New York for \$224.81, and he also served a summons in a suit begun by the Roy Watch Case Co., of the same city, for the recovery of a claim amounting to about \$250.

Mr. Enney has been hard pressed for some time, and inability to collect from his own debtors is put down as the principal cause of his present embarrassment. He lost \$3,000 by the failure of Featherly & Martels, wholesale and retail jewelers; and J. R. Levison, the man who came here some weeks ago and obtained a large amount of goods under alleged false pretences and then hurried off to Chicago, took him into camp to the extent of \$1,200. It has not been decided yet whether or not the business is to be closed out.

A meeting of the creditors of Frank D. Enney was held in the rooms of the New York Jewelers' Board of Trade, New York, last Wednesday afternoon with Geo. E. Fahys, of Joseph Fahys & Co., in the chair. There were seventeen creditors present representing an indebtedness of about \$4,300.

Mr. Enney was present and stated that that his liabilities were as follows: Merchandise, notes and accounts, \$13,216.63; Bank of Syracuse, \$9,351.59; Mrs. A. A. Enney, \$2,000; Mr. P. Enney, \$500; of H. Redway, \$3,000; J. H. Redway, accumulated interest, \$300; making a total of \$28,668.22. The assets are, stock and memorandum account, \$11,227.23; ledger, \$4,577.76; tools and fixtures, \$1,000; notes, 292.54; cash on hand or in hand, \$85.13, jobs and goods undelivered, \$16.35, making a total of \$17,199.01.

Mr. Enney further stated that his net loss in the Featherly & Martels failure was \$2,880, of which he thought he would realize about 25 per cent. When in August last he asked for an extension, his affairs made a much better showing that they do now and he attributes this to the fact that at that time he counted all his outstanding accounts as realizable and that he wanted to make as fair a showing as he possibly could to carry

the extension. He now offers 25 per cent. cash, but the creditors thus far have not decided what course they will pursue.

Incorporated to Work the Missouri Onyx Mines.

St. Louis, Mo., March 13.—The papers for the incorporation of the Ozark Onyx Co. of St. Louis were sent to Jefferson City last Saturday, and as soon as the official certificate of incorporation has been received the company will elect officers and otherwise complete their organization. With one exception the incorporators are all St. Louis men and the capital invested is St. Louis capital. G. H. Reynolds, who is to be the general manager of the works, will remove here from Vermont in a few weeks and make his home here in future. The other incorporators who with Mr. Reynolds will constitute the Board of Directors until the first annual election, are J. F. Leighton, H. E. Rood, T. B. Boyd, L. N. Blackmer, L. W. Post, J. D. Bascomb, J. J. Broderick, E. F. Williams, M. M. McKeen and J. H. Lightner. The capital stock is to be \$300,000 in \$10 shares, and has been entirely taken by the gentleman named.

Prof. Wm. B. Potter, of Washington University, and Manager of the St. Louis Stamping and Testing Works, has made a report upon the discoveries in which he says:

The Missouri "Onyx" as represented by these samples is of the same variety of mineral as the "Mexican Onyx," and sample marked No. 40 especially resembles in appearance the highly-prized delicate green varieties from Mexico. The hardness of the samples sent us compares very favorably with that of samples of "Mexican Onyx" which we have on hand and varies, in the scale of hardness, 3.6 to 4. The high polish and fine finish which these samples exhibit afford satisfactory proof of the adaptability of this material to a great variety of uses as an ornamental stone, and in this particular it compares well with the "Mexican Onyx." An analysis of a characteristic sample taken from the lot sent us gives the following results and shows the great purity of the material:

Lime Carbonate.....	99.84 per cent.
Magnesia.....	None.
Iron and Alumina.....	None.
Silica.....	None.
Moisture.....	0.33 per cent.
	100.17 per cent.

In view of the above, we have no hesitation in stating that the quality of the "Missouri Onyx" as represented by the samples examined, is entirely satisfactory and such as to make it well adapted for its application as an ornamental stone and for all purposes for which the well-known "Mexican Onyx" is used.

Respectfully yours,

St. Louis Sampling and Testing Works,
WILLIAM B. POTTER, Manager.

Ludwig Hess Did Not Get Satisfaction.

Ludwig Hess, of the Manhattan Watch and Jewelry Co., 611 Broadway, New York, last Thursday caused the arrest of Fred. F. Norton, of Brooklyn. He charged him with trying to procure a gold chain worth \$38.00 from him under representation that he was F. F. Norton, manager of the B. & O. Telegraph Co. In the Jefferson Market Police Court Manager Norton said he had been annoyed by a man using his name but he could not mention when the accused had

obtained money by such misrepresentation, and no complaint could be entertained.

Then the prisoner told the Judge that a week ago he had bought a gold chain from Ludwig Hess, on the instalment plan, and had paid \$10, but that the latter had refused either to deliver the chain or return the money until an investigation had been made. He returned to the store last Thursday to make another effort to obtain his money, and was arrested. Justice McMahon discharged him and advised him to sue for his money.

Politicians Discover a Fire.

WINDSOR, Ont., March 11.—The rear end of the store of Bradley Bros., of this town, was, a few nights ago, damaged by fire. A political procession was forming on Onellette ave., and the fire was noticed by those standing in front of the store. The fire was soon extinguished by the fire brigade.

The loss on the stock was \$500, and on the building \$100; both are covered by insurance. The cause of the fire is unknown.

J. M. Seligman, of New Orleans, in a Nervous State.

NEW ORLEANS, La., March 14.—The event of to-day, the lynching of eleven of the nineteen Italians who were indicted on the charge of being implicated in the murder of Chief of Police Hennessy, will compose a chapter in history. Business has been almost entirely suspended throughout the day. The feeling of indignation against the jury who acquitted some of the prisoners and disagreed as to others, verges almost upon the desire for vengeance. The feeling against the foreman, who happens to be J. M. Seligman, a member of the jewelry firm of S. H. Seligman & Bro., is especially threatening.

The Stock Exchange of which Mr. Seligman was a member, met to-day and discussed his action. As a result of the discussion he was expelled, the following resolution being unanimously adopted:

Whereas, J. M. Seligman, a visiting member of this Exchange, has by his action as juror in the Hennessy case, evidently contributed to defy justice, ignore the laws and scandalize the community, be it

Resolved, That he hereby be expelled from this Exchange, and that his dues for the year be returned to him.

The Young Men's Gymnastic Club, of which he was a member, also met and expelled him, as did the Harmony Club, the leading Jewish social organization of this city. S. H. Seligman, his own brother, and the senior member of the firm, publishes an advertisement to-night declaring that his brother is no longer a member of the firm.

Finding the situation threatening, and believing that his life was in danger, Mr. Seligman started for Cincinnati and went to the New Orleans and North Eastern depot to take the train, where he was overhauled by a number of citizens and would have been roughly handled but for the timely arrival of the police. He was taken to the Fifth Precinct Police Station, where he was held until the crowd dispersed, when he was released.

Fort Worth, Tex., Fruitful in Robberies.

FORT WORTH, Tex., March 11.—To-day it was learned that W. C. Seyfriedt, 311 Main St., who several weeks ago was robbed of stock valued at about \$2,000, has recovered from the thieves, through third parties, all of the customers' watches stolen from his place, and also a portion of the new goods. In order to get back the goods Mr. Seyfriedt had to give about \$350. The value of the goods returned is over \$1,000. Mr. Seyfriedt is not inclined to talk. He said to THE CIRCULAR reporter: "I don't think it safe for me to make any statements about the matter, because the fellows might waylay and kill me."

It is now thought that B. C. Wells' \$2,500 robbery of night before last was the work of the same gang that robbed Mr. Seyfriedt and that an attempt will be made to return the goods on the payment of a small part of their value in cash. Two rings evidently dropped by the thieves were returned to B. C. Wells to-day. Mr. Wells says he has already been approached by a man who stated that he knew who committed the burglary, and if the money would be put up the stolen goods could be recovered. Numerous recent burglaries all tend to the belief that Fort Worth is in the hands of a gang of professional crooks.

Sheriff Richardson last night arrested Rube Arlington as an escaped convict in the hall of the Y. M. C. A., where a social entertainment was in progress. Arlington was dressed in the height of fashion and was surrounded by admiring friends, male and female. He accompanied the sheriff to jail without asking any questions.

Death of Charles J. Clase.

PROVIDENCE, R. I., March 11.—Death has claimed another well-known manufacturing jeweler from this city, this time visiting the firm of Vennebeck & Clase, and taking Charles J. Clase who has been well and favorably known in the trade for nearly a quarter of a century.

Mr. Clase was a native of Sweden, where he was born in January, 1826. After receiving a thorough education he entered the merchant marine of that country, and by indefatigable energy and perseverance he steadily rose until he became captain, in which capacity he sailed for several years, until he met with a painful accident which impeded the use of one of his legs.

About twenty-five years ago he came to this country, taking up his residence in this city, and soon after his arrival obtained employment in the gold-plating establishment of Edwin Lowe. Here he remained until early in 1881, when he entered into partnership with Thomas R. Vennebeck in the plating business under the style of Vennebeck & Clase, at 107 Friendship St.

For several months he had been ailing from a complication of diseases, but his death came almost unexpectedly. He leaves a widow and two daughters in Sweden.

Jewelers in Rhode Island Politics.

PROVIDENCE, R. I., March 14.—The annual gubernatorial election which takes place in this State on April 1st is the subject uppermost in the minds of citizens at the present time and considerable interest is being manifested on all sides. Nor are the jewelers lacking in enthusiasm and many of the manufacturers are prominent in the political arena. At the present time Providence has a manufacturing jeweler in the mayor's chair, C. S. Smith, while in the City Council are G. L. Vose, H. S. Dorchester and Edwin Lowe.

In the present campaign are to be found the following: Delegates to Republican City Convention—Fred I. Marcy, W. B. Frost, B. L. Hall, G. H. Heathcote, J. L. Remlinger, P. F. Parsons, C. H. Perkins, J. M. Buffington and J. H. Fanning. Delegates to Republican State Convention—Fred I. Marcy, Lewis Patstoue, H. S. Dorchester and Edwin Lowe. Members of Republican City Committee—G. H. Wood, John Heathcote, G. H. Holmes, S. A. Bennett and S. H. Manchester. Nominée for Republican representatives—Ward 8, Edwin Lowe. Delegate to Democratic State Convention—From East Providence, C. W. Grube. Members of Democratic Town Committee of East Providence—E. F. Seery, C. W. Grube and E. F. Gottschalk.

Ehrlich Brothers Quarrel.

CHICAGO, Ill., March 11.—A receiver was appointed yesterday to sell the assets for the benefit of the creditors of Ehrlich Bros., jobbers and manufacturers, 172 Market St., on a bill filed by Samuel Ehrlich against Moses Ehrlich. The quarrel between the brothers has caused considerable surprise. Samuel Ehrlich recently filed a bill in the Circuit Court asking for dissolution of the partnership existing between him and his brother.

The firm was formed January 1, 1884; Samuel contributed \$4,000 to the business, and Moses \$2,000, the agreement being that they were to take two-thirds and one-third of the profits respectively, and share the losses in the same ratio. Moses had charge of the books and had always said that the business was profitable. Samuel says in his petition that he was on the road most of the time and took Moses' word, until recently he received some information which caused him to look over the books and he then discovered that there were \$14,000 of unpaid bills and that there were total liabilities of \$24,500, and assets of but \$16,000.

PROVIDENCE JEWELERS INTERESTED.

PROVIDENCE, March, 14.—During the past week news was received in this city of the failure of Ehrlich Brothers, Chicago. The members of the Manufacturing Jewelers' Board of Trade of this city have claims against them amounting to about \$9,000, while the total indebtedness in this vicinity is estimated at nearly \$25,000.

J. C. Harrington & Son Go to the Wall.

PROVIDENCE, R. I., March 13.—J. C. Harrington & Son, 129 Eddy St., gave a trust deed a few days ago to George L. Vose, of G. L. Vose & Co., 59 Clifford St., this city. This deed was given for the purpose of making a settlement with all their creditors, and amounts practically to an assignment.

Messrs. Harrington have been desirous of closing out their business, that of manufacturing bracelets, for several months, but having had no advantageous opportunity, have continued with satisfactory results. They were forced to the step of giving the trust deed by the foreclosure of a mortgage of \$1,500 by D. C. Percival & Co., Boston, Mass., and the firm will probably now cease business.

The firm has experienced considerable adversity during its existence. Mr. Harrington, senior, first started manufacturing jewelry before the war, but when hostilities broke out, he closed his business and went to the front. After his discharge he returned to this city, and again started in business in 1869. After experiencing various vicissitudes, he was obliged to succumb and assigned in June, 1876. Effecting a settlement with his creditors, he again launched into business, but again he was forced to make an assignment on Oct. 29, 1889, with liabilities amounting to between \$4,000 and \$5,000. Effecting a settlement at 20 per cent., and taking his son into partnership with him, he once more ventured in business, with the result as above. The business is solvent, Mr. Harrington claiming that, although the firm will pay every dollar of its indebtedness, the members will be worse off financially than when they started about eighteen months ago.

The Goods Must be Returned.

PROVIDENCE, R. I., March 16.—As previously reported in THE CIRCULAR, the firm of Towne & Ingraham has dissolved by the withdrawal of E. B. Ingraham. As stated at that time Mr. Ingraham took a considerable amount of stock, tools and machinery from the shop of the firm, 29 Point St., without the knowledge of Mr. Towne, and commenced business for himself as agent at 127 Summer St. As soon as Mr. Towne became acquainted with this condition of affairs he applied to the Supreme Court for a receiver, and Phineas F. Parsons, the Providence agent of the Waterbury Brass Company was appointed.

Mr. Parsons' first move under direction of the court was to demand of Mr. Ingraham the return of the goods taken. No notice being taken of this demand, the court called the case up for trial last Wednesday at which it was adduced that Mr. Ingraham went to New York, unbeknown to his partner and succeeded in collecting between \$1,500 and \$1,600 which he had used for himself. He also stated that he had taken from the shop forty-five complete sets of button tools, all the seamless wire chain on hand and machinery, tools, etc., enough to amount in value to about \$500. After hearing the arguments

the court decided in favor of the plaintiff Towne and ordered all the stock, tools, machinery, money, etc., taken to be returned before Saturday night, March 14.

Mr. Towne says that he does not know what he shall do about continuing, and will have to wait until the present condition of affairs is settled before he can decide.

Flames and Water Damage A. Kornblum's Stock.

PITTSBURGH, Pa., March 12.—Sparks from a burning building in the rear last night set fire to the roof of the building at 60 Fifth Ave., occupied by Mrs. A. Kornblum, the optician, and caused considerable damage, but water was turned upon the flames and they were readily extinguished.

The principal loss was caused by water which damaged the stock to the amount of \$1,500. Mrs. Kornblum was insured to the extent of \$6,800.

Blown Through a Plate Glass Window.

PITTSBURGH, Pa., March 15.—A heavy wind-storm to-day did considerable damage to the large plate-glass window in George W. Biggs Co.'s store. The janitor, who was on a ladder in front cleaning the window when the storm came up, was blown through the pane and across the show-case into the store.

Louis Evans, a watchmaker, was severely cut, and several clocks and pieces of bric-a-brac were broken. The glass was ten feet square, and valued at \$450. The total damage was about \$700.

Assignee Graham Not Yet Removed.

CLEVELAND, O., March 13.—The attorneys representing creditors of Sumner Bros. have held a meeting to elect a trustee to succeed assignee T. H. Graham. Mr. Graham is objected to as an assignee by creditors in the East, on the ground that he acted as attorney for Sumner Bros. when they were in a solvent condition.

Attorney C. C. Young moved that a vote be taken on the retention or removal of the assignee. He was cut short by a motion made by Judge C. E. Pennewell to adjourn until a week from to-morrow. The motion was carried by \$67,000 to \$51,000. The meeting then adjourned until March 21.

A Salesman who Pawned his Samples.

BOSTON, Mass., March 12.—Augustus Mack, salesman for A. D. Cairns & Co., 363 Washington St., was brought to this city from Milwaukee, Wis., on the 10th inst., under arrest. He was charged with the embezzlement of jewelry valued at \$600, the property of his employers, consisting of three diamond rings, fifteen men's vest chains, six women's chains, twenty-three men's rings, twenty-six women's rings, eighteen long chains and about two dozen gold and silver watches.

Mack sold jewelry at retail about the city

for three years prior to Jan. 21, when he suddenly skipped to New York and took his sample case along with him. Subsequently, however, in order to extend his travels to Philadelphia, Baltimore, Chicago and Milwaukee, he had to part with its contents.

From the Chicago police it was ascertained that considerable of the property had been pawned in that city; some of it was recovered there and at other places where he stopped over en route. When arraigned Tuesday afternoon, he pleaded guilty and sentence was deferred. Mack is twenty-eight years old and has a family.

The Disastrous Fires in Syracuse Burn Out Two Jewelry Stores.

SYRACUSE, N. Y., March 15.—In the disastrous fires which occurred in this city yesterday and this morning, N. C. Smith, who conducted an instalment business at 233 E. Fayette St., suffered a loss of \$500; insurance \$625.

Benedict & Wallace conducting an instalment business under the name of the Standard Watch Co., cor. James and Lock Sts., were burned out in the fire of this morning. They had a large stock; their loss is estimated to be between \$25,000 and \$40,000, about half covered by insurance.

The Jewelers' Security Alliance.

The regular monthly meeting of the Executive Committee was held at the Alliance office last Friday. There were present Vice-President Henry Hayes and David Untermyer, J. B. Bowden, Chairman, Chas. G. Lewis, Treasurer, and Messrs. Kræber, Butts, Karsch, and Geo. H. Hodenpyl, Secretary.

The following firms were admitted to membership: Brown, Hixson & Co., Lockport, N. Y., Fred. W. Butler, Albion, N. Y., John Brenner, Youngstown, O., Emil Bihlman, and S. C. Coyle, McKeesport, Pa., Philadelphia. Pa. Arthur S. Goodman, 268-270 South Fifth St., Guthman Bros., Youngstown, O., Charles S. Hauser, 631 Smithfield St., Pittsburgh, Pa., Rudolph J. Henne, 6018 Centre Ave., Pittsburgh, Pa., Chas. Italie, 818 Braddock, Pa., Frank M. Powers, Youngstown, O., Reineman Bros., 190 Ohio St., Pittsburgh, Pa., Walter G. Smith, Youngstown, O., Henry Terheyden, 530 Smithfield St., Pittsburgh, Pa., C. F. & L. Uhl, 141-143 Euclid Ave., Cleveland, O., J. C. Whitlock, 163 Broad St., Eufaula, Ala., Witzel & Pafenbach, 342 Fifth Ave., Pittsburgh, Pa., Youngdahl & Lilja, 273 W. Madison St., Chicago, Ill., D. R. Young, Youngstown, O.

A Salesman Dies and His Samples are Missing.

Daniel McNally, a traveling salesman for the American Watch Club Agency, 20 Maiden Lane, New York, of which Adolph Hess is the manager, died in the Newark City Hospital, Newark, N. J., last Sunday afternoon, from the effect of an overdose of lauda-

num administered by himself, while under the influence of liquor.

McNally, who was known to his friends as "Handsome Dan," parted from his wife some time ago, and the day previous to his death was seen drinking with several young men in various saloons. He obtained the laudanum from a Newark druggist, saying that he desired to induce sleep, as he was suffering from neuralgia.

He lived with his brother at 211 Jersey St., Harrison, N. J. It is said that he had a sample case containing about \$1,000 worth of jewelry in his possession, but that it disappeared shortly before his death. When this statement was mentioned to McNally's employer, Mr. Hess, by a CIRCULAR reporter last Monday, that gentleman said that it was correct. The Newark police located the jewelry on Monday at 218 Harrison Ave., Harrison, N. J.

Another Cleveland Firm Fails.

CLEVELAND, O., March 14.—E. R. Kant, 297 Pearl St. is added to the list of insolvents in this city. After 7 o'clock last evening Mr. Kant and Attorney W. C. Ong called at the Probate Court and filed a deed of assignment to Hamilton Roosa, who accepts the trust and will give bond this morning in any amount the court may name.

Mr. Kant has been unfortunate of late, and finally, finding that he could not meet his obligations concluded to make an assignment. Mr. Ong said last night that it was impossible then to estimate the assets and liabilities, but at a rough guess, Mr. Kant owes between \$8,000 and \$10,000, with assets of the same amount.

Mr. Kant prefers by chattel mortgages on his stock and accounts, W. H. Kees, for \$600; for money loaned his mother, Mrs. Elizabeth Kant, \$5,000, Sigler Bros.; for \$114; Julius King Optical Co., for \$79, and \$2,000 in favor of W. H. Kees as administrator of the estate of W. R. Kant, deceased.

The insolvent attorneys expect that there will be the usual litigation instituted by outside creditors over the preferences, but say that they feel sure of their ground.

Smuggled Diamonds to Be Returned.

Some months ago a man giving the name of Jacob Kronfeld obtained from the Paris houses of Vue L. B. Citreon & Co., and Henri Karminker & Co., \$8,000 worth of diamonds, for which he gave drafts. Before the paper became due Kronfeld disappeared and the firms heard nothing of him until they saw his name in the newspapers in connection with a custom seizure of diamonds in Chicago, Ill., where the authorities held the stones, believing they had been smuggled.

N. Kauffmann, the New York representative of Vue L. B. Citreon & Co., placed the matter in the hands of Attorney Newman, of Chicago, and last week he served garnishment papers on the United States Collector. His firm's claim amounts to \$3,500.

Chicago.

M. Ellbogen, of Stein & Ellbogen, is in Florida.

Optician Ashley, of Giles, Bro. & Co., is quite ill.

W. J. Keating, of Watertown, S. D., has been in the city buying goods.

Louis Boerlin will remove from 63 Washington St. to 165 Wabash Ave.

The Pairpoint Mfg. Co., 90 Wabash Ave., are enlarging and remodelling its quarters.

Planchamp & Becker, watch repairers, 63 Washington St. have enlarged their factory.

G. P. Tuttle, of W. H. Booth & Co., Sioux Falls, S. D., was in the city last week ordering goods.

W. M. Alister, of B. F. Norris, Allister & Co., is in California where he will stay for six weeks.

Lem Flershem, of Lapp & Flershem, and M. N. Burchard, of Simpson, Hall, Miller & Co., have returned from New Mexico.

Goldsmith Bros., the well known refiners at 65 Washington St., have a gold brick in their establishment worth several thousands of dollars.

The firm of Greifenhagen & Bisson has been succeeded by Stern Bros. & Bisson. Mr. Greifenhagen will remain with the concern as general manager.

A silver brick weighing 100 ounces was stolen from the Smelting Company at South Chicago. Anton Evans has been arrested and confessed his guilt.

The Jewelers' Council of the National Union met on the 9th. It is a prosperous social organization and contains some of the best men in the city. The council will meet April 9th.

E. H. Heppel, a New York jewelry salesman, who was stopping at the Auditorium Hotel, on waking the other morning found that his watch and money were gone. A young man named Hancock was arrested for taking them. He confessed his guilt but said he merely took them for safe keeping. Heppel took his valuables and refused to prosecute Hancock.

The police are looking for Mrs. M. B. Curtis, wife of "Samuel of Posen" Curtis, the actor, to secure something tangible that might be attached on a claim in favor of Charles Caspar, 36 E. 14th St., New York. Mr. Caspar last December loaned Mrs. Curtis \$500, and gave her \$292 worth of jewelry for which she never paid. The police have found nothing and have finally attached her salary.

The building known as the Jewelers' Exchange, corner of Washington and State Sts., will, when the repairs now being made are completed, be one of the finest office buildings in the city. In it are located, among other firms, the following: The Illinois Watch Co., Courvoisier-Wilcox Mfg. Co., R. Wallace & Sons Mfg. Co., Western Watch Case Co., American Waltham Watch Co., M. A. Mead & Co., F. E. Morse & Son.

Pittsburg.

M. G. Cohen has just finished laying an oak floor in his new store at 36 Fifth Ave.

James Sheafer, of Sheafer & Lloyd, who has been on a purchasing trip to New York, has returned home.

Mr. and Mrs. W. W. Wallis have gone on a trip to Virginia Beach near Norfolk, Va., They will also visit Old Point Comfort.

An awning in front of Sheafer & Lloyd's store caught fire from flying sparks one evening last week and was completely destroyed.

J. O. Slemmons is conducting auction sales daily, with a view to disposing of his entire stock of goods. It is likely that he will retire from the wholesale business and enter the retail trade.

The following jewelers offered prizes to be competed for at the Bench show held here this week: J. C. Grogan, C. S. Hauser, Sheafer & Lloyd, August Loch, Allegheny City, W. W. Wattles, G. W. Biggs & Co. and Durbin & McWatty.

Boston.

Fred Fletcher, who has been in E. B. Horn's employ for some time, has connected himself with Morrill Brothers & Co.

Ten shares of American Watch Company stock strayed into State St. this week, and were sold over the board. They brought \$169 per share.

Traveling men in town this week were: Henry Dreyfus, Otto Wormser, W. H. Tarlton, Charles Van Ness, New York. E. J. Scofield, New York agent of the Elgin Watch Co., accompanied by Mrs. Scofield, were entertained at dinner Friday by D. C. Percival.

By recent arrangement, an agreement has been made with E. B. Horn, that he will retain an interest in the new firm announced last week as his successor. The value of the name so long connected with the establishment is recognized in the style of the corporation formed, which will be known as the E. B. Horn Company, with Mr. Horn as President, C. A. Woodsome, Treasurer, and W. A. Whittemore, Secretary. The two latter gentlemen are from Waltham, where they have just disposed of their store.

St. Louis.

J. Linz & Bro., who recently sold out their establishment at Sherman, Tex., will soon remove to this city and open a jobbing house.

C. G. Derleth, of Greenville, Ill., will remove to East St. Louis, where a genuine real estate boom is at present raging with great force.

Mrs. R. Haberman has rented the handsome store at 602 Olive St., and will remove from 216 North 4th St. as soon as the necessary change can be made in the fixtures.

J. F. Bolland has returned from a trip to Reading, Pa., bringing with him his bride.

The marriage ceremony was performed in Grace Lutheran church, at Reading. Mr. and Mrs. Bolland are residing at the Southern Hotel.

The Mermod-Jaccard Jewelry Co. are making a magnificent display of solid silverware in enormous plate glass show-cases measuring twelve by six feet. The cases are only 18 inches deep, and lie flat under a strong grouping of electric lights. The effect is very attractive.

The following traveling men, last week registered at the Mermod-Jaccard Jewelry Co.: A. R. Dorchester, of Brown & Dorchester, Providence, R. I., next address, Gibson House, Cincinnati, O.; J. G. Schwarzkopf, of Bippart & Co., Newark, N. J., next address, Paxton Hotel, Omaha, Neb.; H. A. Bliss, of Kremetz & Co., New York, next address, Coates House, Kansas City, Mo.; J. E. Simonson, of A. J. Hedges & Co., Newark, N. J., next address, Palmer House, Chicago, Ill.; J. D. Linderwood, of Champenois & Co., Newark, N. J., next address, Brevoort House, Chicago, Ill.

Philadelphia.

A judgment for \$1,520 has been entered against J. Seffers, Philadelphia, Pa.

Jacob Muhr has been elected a member of the Board of Directors of the Hebrew Education Society.

A Philadelphia music publishing house has issued a new song, "The Waterbury Watch." It ought to go.

David Craig, 4 Rodgers Court, was committed for trial on the 10 inst. by magistrate Kane, on the charge of selling bogus jewelry. Philadelphia within the last month or two, has been overrun by such sharpers.

New York was well represented here during the past week, in the number of travelers; W. H. Macdonough, of the Corvoisier-Wilcox Manufacturing Co., Frank Woods, of Carter, Sloan & Co., Charles Duffy, of Enos Richardson & Co., David Kaiser, of Lewis, Kaiser & Luthey, Edward Eckfeld, of W. B. Kerr & Co., and Mr. Bailey, of the Roy Watch Case Co.

Considerable excitement was caused last Wednesday morning by a runaway horse plunging through the big plate glass window in the jewelry department of John Wanamaker's store. In going through, the horse broke the glass into a thousand pieces, and he fell on a table inside, upsetting, but not damaging, goods ready for delivery. The occupants were uninjured.

Harry Colchter, a brakeman employed on the Baltimore & Ohio Railroad, was given a hearing before Magistrate Pole on the 13th inst., charged by John Reese, a jeweler of 3314 Lancaster Ave., with obtaining a watch by false pretences. The transaction was in the nature of a loan sale, Colchter obtaining the watch on the representation that he wanted to sell it to his brother-in-law. The prisoner was held in \$600 bail for court.

Syracuse.

E. B. McClelland has returned from New York and Chicago.

D. Valentine, of New York, was visiting at his home in this city during the week.

The New York House Furnishing Store, at 122 E. Genesee St., owned by L. A. Graff, has had a silverware department added to it.

F. H. Wells just returned from New York and among the many novelties he has secured for his new store, is a magnificent specimen of porcelain painting. It is a genre subject from Hans Markart's painting of a celebrated Austrian actor. The work is about 12x17 inches and is valued at \$500.

G. Lawrence, of H. C. Hardy & Co., Mr. Ackley, of Unger Bros., W. S. Campbell, of Day & Clark, J. E. Ham, of Ed. Todd & Co., D. L. Tirrel, of M. Fox & Co., Mr. Woodland, of Larter, Elcox & Co., H. C. Barnum, of Shafer & Douglas, F. W. Harmon, of M. B. Bryant & Co., and E. E. Kipling, New York, G. A. Bicknell, of F. S. Gilbert, No. Attleboro, Mass., Mr. Crane, of Strobell & Crane, and W. S. Montgomery of Cory & Osmun, Newark, N. J., and J. S. Judkins, of D. Wilcox & Co., and W. W. Middlebrook, of B. A. Ballou & Co., Providence, R. I., were among the traveling men in town during the past week.

Newark.

The Chicago Watch and Jewelry Company have moved into their office at 224 Market St.

Cortlandt Parker has in his possession a pewter brandy flask which was taken from the body of "Fighting Phil" Kearney, when that gallant general lost his life on the fields of Chantilly. J. Kendall Smith oxydized it last week for Mr. Parker.

All jewelry left for repairs several weeks ago at Linde Brothers' store, 741 Broad St., may be obtained by calling on or addressing G. Linde, 32 John St., New York. Linde Bros.' stock was sold at auction some time ago, and the firm removed from this city.

Nothing further has been learned of the two successive robberies of Kolomon Bertl's jewelry store than what was told in THE CIRCULAR's last issue. The police think they have a clear case against the arrested men, and the Grand Jury, with whom the matter rests at present, will undoubtedly bring an indictment.

The sale of the Riley-Osborn Manufacturing Company's property in this city was effected on Saturday by Receiver J. F. Fort, and the sale received the sanction of Chancellor McGill. The buyer was Samuel Klotz, and it is believed he will be the president of a new company to continue the manufacture of fancy brass goods. His original offer was \$55,000. It was raised a thousand by a bid of J. B. Mayo, the jeweler, and Mr. Klotz saw him and raised him a thousand. Mr. Mayo dropped out and Mr. Klotz took the property at \$57,000. It consists of a huge

new factory in Mulberry St., full of fine machinery, and is regarded as a good bargain for the buyer. The creditors will get about \$75,000, which is nearly full satisfaction for all demands.

Aurora.

G. O. Clayton, member of the firm of O. S. Clayton & Sons, is now nicely located in a handsome new residence on Downes Place.

B. F. Spranger has been considerably annoyed of late by the loss of valuable articles from the store. He has finally succeeded in tracing the thefts to C. A. Parrott, a young man employed by him. Parrott was arrested on Tuesday.

Miss Callie Reynolds, of this city, will receive \$500,000, willed to her by her uncle, the famous Diamond Joe, who died recently. The girl is the daughter of the late James Reynolds, of this city, a brother of Diamond Joe. She says the legacy was entirely unexpected.

F. B. Rice, of the Aurora Silver Plate Co., left last Thursday on a trip to New England, in the interests of his concern. While away, Mr. Rice will make yearly contracts for supplies. The business of the company is increasing to such an extent that the factory building will be enlarged in the near future.

Everything is running smoothly at the rejuvenated Aurora watch factory, and at present nearly a hundred hands are employed in working up the old stock, while several experienced mechanics have lately been added to the force. The new movement has been placed in the hands of the traveling salesmen.

Lancaster, Pa.

Ernest Zahm visited the trade in New York, Newark and Philadelphia the past week.

John Gemperling, an employee in the factory of Ernest Zahm, last week had his hand lacerated and bruised while cleaning a roller.

W. W. Appel, of Hamburg, this State, has rented the store 170 North Queen St., this city, and will open with a large stock about April 1st.

Aug. Rhoads, shipped to New York this week a grandfather's clock, the second of the kind which he has sold to the same customer within the past months. It was made by Shreiner, of this city, about eighty years ago.

There has been some talk among local capitalists of forming a syndicate to purchase the plant of the Lancaster Watch Co., with the object of holding it as an investment, or, if the outlook is favorable, resuming the manufacture of watches. The factory is situated in a very desirable section of this city.

Among the traveling men in town the past week were: Mr. Elcox, of Larter, Elcox & Co., August Freund, of Max Freund &

Co., Fred Kaffeman, J. W. Eckstein, of Oppenheimer Bros. & Veith, and Mr. Lehmann, of Waterman & Lehmann, New York, E. J. Smith, of the Holmes & Edwards Silver Co., Bridgeport, Conn., N. F. McGown, of W. M. Fisher & Co., Providence, R. I., G. W. Bleecker, of the Bassett Jewelry Co., Newark, N. J., and W. J. Barber, of Simpson, Hall, Miller & Co., Wallingford, Conn.

Canada and the Provinces.

C. E. White, Milton, Ont., is selling out.

H. V. Dalling, Woodstock, N. B., has been burned out.

T. L. Wilson, of Woodstock, Ont., is about to enlarge his store.

Auction sales are being conducted at J. T. Bolt's store, Montreal, P. Q.

J. J. Le Heup has moved from Kingston, Ont., to Mattawa, same province.

George Kenrick, of Reed & Barton, Taunton, Mass., was in Montreal last week.

Alexander Cameron, Mitchell, Ont., was called last week to West Zona, to the bedside of his dying mother.

The stock, fixtures and book accounts of the firm of Beath & Paris, Sudbury, Ont., are for sale by tender. The whole is valued at \$1,707.33.

Chas. Stark & Co., Toronto, Ont., have at the Jamaica exhibition a handsome case of watches. The firm hope to establish a market in Jamaica.

E. A. Woodmoney, of Potter & Buffington, Providence, R. I., is making a Canadian tour. He was in Montreal last week, and is now in Toronto.

J. H. Laidlaw, Sarnia, Ont., is said to be financially embarrassed. Being in default with two chattel mortgages his stock was advertised to be sold last week.

W. A. Walker, Montreal, P. Q., who is moving to new and elegant quarters in the jewelry section of that city, is about visiting New York to get ideas on display, etc.

John Leslie, a well-known jeweler of Ottawa, Ont., is about to sell off his stock and retire from business. For nearly fifty years he has carried on a good business in that city. He will sell at a large reduction for cash.

Found a Kit of Burglars' Tools.

ESSEX, Conn., March 11.—Two boys while rabbit hunting in the "great swamp" between that place and old Saybrook, Saturday, found at the foot of a ledge, carefully covered up with leaves, a large wooden box containing a cracksman's complete outfit. There was a fine sectional "jimmy," an apparatus for blowing powder into a safe, and a set of wedges which would, if properly used, force off the door of any safe in Middlesex county. All of the tools were covered with rust, and their condition told plainly that they had lain in their hiding place for a long time.

Providence.

C. P. Tillinghast visited New York the past week.

A jewelry shop at 102 Friendship St. is advertised for sale.

A. B. Day & Co. have removed from 195 Eddy St. to 29 Point St.

W. H. Waite, of Waite, Thresher & Co., has recently purchased real estate.

Joshua G. Rider has started in the retail business at 355 Westminster St.

E. L. Logee & Co. have just added two large safes to the office furniture.

A. A. Wightman, of Wightman & Hough, is enjoying a pleasure trip to the Pacific slope.

N. B. Barton, of Ostby & Barton, has returned from a successful southern and western trip.

The Holmes Mfg. Company have commenced the manufacture of fancy wire for jewelers' use.

Charles Darling is on a Western trip for L. W. Pierce & Co., and will be away until early in April.

Alexander Brough, jewelry buyer for Callender, McAuslan & Troup, of this city, was in New York last week.

C. F. Irons and N. B. Barton have been elected associate members of the Business Men's Association of this city.

J. M. Chandler, of the J. M. Chandler Co., of this city, is still in Cleveland, but is expected to return in a few days.

The New England Manufacturing Jewelers' Association will hold its annual winter reunion in Spink's Hall on the evening of April 8.

A petition to incorporate The Edwin Lowe Gold Plate Company has been continued until the next session of the General Assembly.

D. S. Parkhurst has the sympathy of a large circle of acquaintances in the death of his wife on the 11th inst., in the 59th year of her age.

E. S. Luther has been elected a member of the financial and of the entertainment committees of Juniata Council, Daughter of Pocahontas.

S. S. Smith has the refusal of the third floor of the Ladd Building now in process of erection, and will probably occupy it as soon as completed.

W. R. Dutemple has been appointed a member of the committee of finance of the Grand Encampment of Odd Fellows of Rhode Island.

A number of patrons of the Hotel Dorrance presented George Cross, the genial proprietor, with a 14-karat diamond in gold setting, last week.

W. L. Ballou & Co. have applied to the Rhode Island Legislature for a charter to incorporate under the style of The William L. Ballou Silverware Company.

The revival of an old and pretty fashion of wearing coral jewelry, has already been

productive of the appearance of several charming novelties in coral in the show windows of some of the most prominent retailers.

The regular monthly meeting of the Board of Directors of the Manufacturing Jewelers' Board of Trade will be held in the rooms in the Wilcox building on the 21st.

There was a regular exodus of salesmen from this city the first of last week to the land of promise, New York, where they met with more or less varied success.

Thomas Winn, a stone mason at work on the Ladd Building in process of erection at the corner of Clifford and Richmond streets, was severely injured Tuesday by a falling derrick.

C. S. Capron has withdrawn by mutual consent from the firm of Palmer & Capron, 120 Dorrance St. The business will be continued by J. S. Palmer, Julius Palmer and A. Pierce under the old name.

G. H. Slade has been elected President of the Rhode Island Yacht Club. Mr. Slade is well remembered by manufacturing jewelers in this vicinity as being the first secretary of the Manufacturing Jewelers' Board of Trade.

Among the foreign importations into this city last week were seven cases of candelabras from Liverpool; two packages of imitation stones from Bremen, and one package of precious stones from Havre. The total valuation was \$22,684.

The firm of Remlinger, Ohler & Felder, which started in the manufacture of rings under the style of Ohler & Co., about the first of the year, have gone out of business, feeling that "the long felt want" which they started in to fill has long since been supplied.

A cash offer of thirty cents on the dollar is being generally accepted by the creditors of Tabor Brothers, of Dallas, Tex. who failed recently with total liabilities amounting to \$30,594.13, of which about \$13,500 is represented here, divided among some thirty-five firms.

It is a somewhat unusual occurrence to find an advertisement in the local papers at his season of the year for additional help in a jewelry manufactory, yet this is what Hamilton & Hamilton, Jr., are doing, notwithstanding they have 175 hands already employed.

Among last week's corporation returns are the following statements:—American Enamel Company—capital stock, \$100,000; real estate, \$15,780; personal assets, \$38,401.32; liabilities, \$14,458.74; and the Nicholson File Company—capital stock paid in \$400,000; real estate, \$167,600; personal assets \$401,766.45; liabilities \$160,986.68.

The Standard Seamless Wire Company, of 30 Bayley St., Pawtucket, has just received from the factory of H. Blundell & Co., of this city, a pair of 10-inch rolls, weighing nearly 7 tons. They are also having constructed two rotary hammers, which will make five to be used in the manufacture of

gold-plated, seamless wire. When this additional machinery is in operation, the production will be 5,000 ounces a day.

Sumner Brothers, 204 Superior St., Cleveland O., who owe about \$25,000 in this city, half of which is outside of the Board of Trade, have made an offer of sixty cents in unsecured notes, but the offer is not meeting with favor among the eastern creditors. The appraised assets amount to \$89,655.88; direct liabilities, \$85,000 and contingent liabilities to \$101,300.

Connecticut.

J. B. Capron, recently of West Gardner, Mass., is now located at Bridgeport.

E. E. Penny, for three years head clerk for S. H. Wood, New Britain, has accepted a position with L. S. Stowe & Co., Springfield, Mass.

Secretary Curtis, of the Meriden Silver Plate Co., Meriden, has been sadly bereaved in the very sudden death of his wife, on the evening of March 6, from heart disease.

C. H. Case, Hartford, now has one of the handsomest jewelry stores in the Nutmeg State, having recently refitted it entirely, put in new cherry cases, a cash system, and added many other improvements of a decorative nature.

Quite a commotion was occasioned in New Haven, last week, in the many stores and offices where electric clocks are in use. The clocks suddenly stopped, or became irregular by reason of the wires becoming crossed during a heavy rain storm.

The Bristol Silver and Copper Mining Co., of Bristol, have just given a contract for the erection of a new crushing plant, which is to be put in at once. Its capacity for separating will be 100 tons of ore a day. The miners are at work with good results in the lower drifts.

Mrs. A. D. White, widow of the late A. D. White, has decided to continue the New Haven store. Mr. Bennett, president of the Winchester Repeating Arms Co., who owns the building in which the store is located, has decided to temporarily defer his plan of tearing it down and erecting a new one on its site.

I. C. Lewis, president of the Meriden Britannia Co., is one of Meriden's leading Universalists and a very liberal supporter of the church. To aid the society still further he, last week, bought its old church edifice and will remove it to a new location, giving the society the free use of it until their new and beautiful church is completed.

Gen. Geo. H. Ford, New Haven, has received many congratulations upon his enterprise in buying the Simpson Building. He is making active preparations for commencing as soon as the weather will permit his projected alterations and enlargement of his store, and is also announcing a special sale of all large imported goods in his stock in order to make room.

SOLID SILVER COFFEE SETS.

AFTER DINNER
COFFEE POTS.

ODD AND UNIQUE DESIGNS.

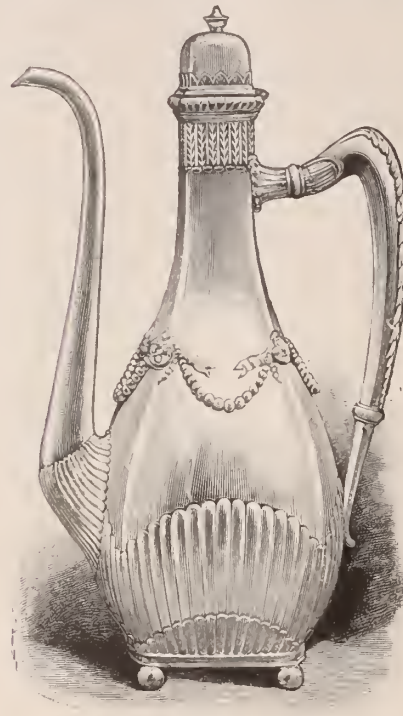

TURKISH, MOORISH
AND OLD ENGLISH

DECORATIONS, WITH SUGAR DISH,
TONGS AND TRAY TO MATCH.

GORMAN MFG. CO.,
SILVERSMITHS,

Broadway and 19th St.,

NEW YORK.

ALFRED H. SMITH & CO.,

DIAMONDS,

182 BROADWAY,

COR. JOHN STREET,

NEW YORK.

33 HOLBORN VIADUCT, LONDON, E. C.

THE JEWELERS' CIRCULAR AND HOROLOGICAL REVIEW.

PUBLISHED EVERY WEDNESDAY BY

THE JEWELERS' CIRCULAR PUB'G CO.,
AT NO. 189 BROADWAY, NEW YORK CITY.

A JOURNAL DEVOTED TO THE INTERESTS OF
WATCHMAKERS, JEWELERS, SILVERSMITHS,
ELECTRO-PLATE MANUFACTURERS AND ALL
WHO ARE ENGAGED IN KINDRED BRANCHES
OF INDUSTRY.

Terms of Subscription, Postage Prepaid.

	PER ANNUM
United States and Canada, - - -	\$2.00
To all Foreign Countries, - - -	4.00
Single Copies, - - - - -	.10

ADVERTISEMENT.

Business letters, drafts, checks and post-office orders should be addressed to THE JEWELERS' CIRCULAR PUBLISHING COMPANY, No. 189 Broadway, New York city.

Manuscript from any quarter containing news or discussion of any technical subject within the field covered by THE CIRCULAR will be welcomed. Matter received that proves unsuitable or unavailable will be returned if accompanied by the necessary postage stamps.

Our editorial columns will contain our own opinions only, and we shall present in other columns only what we consider of interest or value to our readers. Applications to print advertising matter as news will not be considered.

Advertising rates in THE CIRCULAR are lower, considering the number of tradesmen reached by its large circulation, than in any other jewelry journal.

Notices of changes in standing advertisements must be received one week in advance, new matter can be received up to Saturday.

Member of the American Trade Press Association.

CLASSIFIED INDEX TO ADVERTISERS, PAGE 28.

VOL. XXII. MARCH 18, 1891. No. 7.

NOTICE.

New subscribers are taking advantage of our combination premiums to a gratifying extent, and to the mutual advantage of all concerned. The offer is an unusually good one, and it is no wonder that it is meeting with such prompt recognition. Subscribers will please bear in mind that it takes from two to three days to select and forward the premiums.

Interesting to Salesmen
It is always a pleasure to record something that redounds to the advantage of that great army of honest, intelligent, stalwart, kind-natured men, commercial salesmen.

The second division of the New York Court of Appeals has just decided in the case where a written contract provided that a commercial traveler shall travel over his route six times a year, paying his own expenses and that he shall receive a commission on all orders accepted from bona fide purchasers amounting to ten per cent. on all goods sold to trade not theretofore sold by the house and five per cent. on all goods to their regular trade, that the traveler was entitled to commissions on all orders made by purchasers on the line of his route whether taken and forwarded by him or not, and also on orders from responsible parties whether accepted by

his employers or not. Though the decision was handed down in an action brought by an individual against a corporation, large concerns as a rule concede the point to their salesmen without any ado. But in many smaller houses, there is a constant friction between salesman and employer regarding the right of commission on orders received from persons on the salesman's route, not called upon by him and even orders given by visitors to the house during the salesman's absence. It seems but right that the salesman should be entitled to commission in such cases, for he signs his contract with the maximum possibilities of his route in his mind, and if he had not called on such or such man, he will do so sooner or later. Regarding acceptable orders, the opinion of a conscientious traveler may be worth more than the report of an agency; if a dealer give satisfactory references, he is entitled to the house's customary terms of credit. Altogether the decision seems to be just and equitable.

An Overrated Metal.
ALFRED E. HUNT, President of the Pittsburgh Reduction Co., before the Boston Society of Arts, recently delivered a lecture on "The properties, uses and processes of production of aluminum," in which he stated that the two chief difficulties which his company have met with in selling aluminum and introducing it into the arts and manufactures of the country during the past two years have been, first, the extravagant, erroneous, and in many cases mischievously misleading claims which have been made concerning the properties of the metal, and second, the equally widespread misleading claims by inventors of processes for the manufacture of aluminum at very low prices. Being one of the leading manufacturers of the metal, Mr. Hunt's opinion in the matter is more apt to be right than the popular belief. The properties of aluminum have undoubtedly been overrated and the revolution that it will cause and is looked forward to in the manufacture of metal goods, it is safe to say, will never take place. Though it has been used with some success in the manufacture of small articles as spectacle frames and thimbles, its employment in cutlery and in art and table wares is a failure.

How the Trade was Covered.
DURING February, a month containing four Wednesdays, over forty thousand copies of THE JEWELERS' CIRCULAR were issued and distributed to the jewelry trade throughout the country. This number exceeds by more than four thousand that which is claimed by any other jewelry journal—a big circulation in itself. It covered the trade containing twenty thousand firms, almost twice. From Maine to California, from the largest city to the smallest hamlet, into the hands of every dealer who is likely to place orders with jobbers or manufacturers, THE CIRCULAR, replete with trade news and information, and attractively-set advertisements, made its way, in every case a welcome visitor.

The Week in Brief.

The diamonds stolen by W. C. Duncan, from Lewisohn & Co., New York, have been found—Henry Adams, Minneapolis, Minn., is missing—The Otay watch factory will move to San Jose, Cal.—Another suit has been instituted against the McBride & Marcellus Co., Cleveland, O.—Edgar C. Savage, Meriden, Conn., died—G. W. Martin has been arrested for selling jewelry supposed to have been stolen from the Washington Museum—Nellie Hayes, the well-known pennyweighter, was sentenced to seven years imprisonment at Montreal, P. Q.—The Boston Jewelers' Club held its annual dinner—Maxwell Sommerville lectured on the Glyptological Art at Philadelphia, Pa.—The fiancée of a young Allegheny, Pa., jeweler committed suicide—The quarterly reports of imports and exports to Sept. 30, 1890, were published. The annual statement of exports and imports for year ending June 30, 1890, were published—Camden, N. J., still at the mercy of thieves—B. Tibbetts, New Haven, Ia., has recovered jewelry stolen from his store.—Another robbery occurred in Brooklyn, N. Y.—Brooklyn, N. Y., jewelers seek better protection against thieves.—The Columbus Watch Co.'s plant will likely be enlarged—Reichenecker & Co., Seattle, Washington, was closed by the sheriff—The losses by fire of A. L. Hosmer, Lockport, N. Y., were adjusted—An interesting suit was brought against Tiffany & Co., New York—Council Bluffs, Ia., jewelers league themselves against one of their members—A long-wanted confidence man was captured at Buffalo, N. Y.—The Edwin Lowe Gold Plating Co., Providence, R. I., will be incorporated—Palmer & Capron, Providence, R. I., dissolved—The offer of Tabor Bros., Dallas, Tex., is being generally accepted in Providence, R. I.—The offer of Sumner Bros., Cleveland, O., was refused by Providence, R. I., creditors—I. C. Lewis, president of the Meriden Britannia Co., benefits the Universalist Church at Meriden, Conn.—The Riley-Osborn Manufacturing Co. property was sold—Diamond Joe bequeathed a half million dollars to Miss Callie Reynolds, Aurora, Ill.—A syndicate may buy the Lancaster (Pa.) Watch Company property—John Leslie, the well-known Ottawa, Ont., dealer is selling out—The Jewelers' Security Alliance held their monthly meeting—B. C. Wells, Ft. Worth, Tex., was robbed, and W. C. Seyfriedt, of the same city, recovered stolen goods—C. J. Clase, Providence, R. I., died—Several Providence jewelers enter the political fight in Rhode Island—The business of Ehrlich Bros. was placed in the hands of a receiver—J. C. Harrington & Son., Providence, R. I., failed—The Jewelers' Council, Chicago, Ill., met—The police attached Mrs. M. B. Curtis' salary—The E. B. Horn Co. was organized at Boston, Mass.—J. Linz & Bro., formerly of Sherman, Tex., will locate at St. Louis, Mo.—The Manhattan Silver Plate Co. will likely remain at Lyons, N. Y.—The Kenosha Watch Case Co., Kenosha, Wis., increased their capital stock.

New York Notes.

In a few weeks Nathan & Herman will move from 15 Maiden Lane to 51 Maiden Lane.

Martin Metzger & Co. have decided to remain in their present offices at 7 Maiden Lane.

C. L. Moak and S. L. Howland, for many years with Peterson & Royce, will soon enter the employ of Eisenmann Bros.

Last week Inspectors Brown and Donohue seized two gold stop watches valued at \$150 each from a passenger on the steamship *Ems*.

The trade is cautioned against an individual calling himself "Mr. Clark, of Benjamin Clark & Bro., Wilmington, Del." He is unknown to that firm.

B. F. Wise, 39 Union Square, made the \$2,000 diamond badge which is to be presented to the winner of the six-days'-walking contest now in progress at Madison Square Garden.

C. W. Schuman's Sons will soon vacate their present store on Union Square. They intend occupying the store in the new building now in course of erection at the corner of 21st St. and Broadway.

Last week S. F. Myers, of S. F. Myers & Co., reached Orlando, Fla. He met the firm's Southern traveler, Mr. Knowles, there, without any previous arrangement, and both gentlemen were agreeably surprised.

Ferdinand W. Cahn, who is alleged to have stolen \$1,500 worth of diamonds from Henry E. Oppenheimer & Co., and who has been awaiting trial on \$3,000 bail since February, was surrendered last week in Jefferson Market Police Court by his mother, who had supplied bond for him.

Jacob Haas, 93 Ridge St., last week secured a pair of diamond earrings valued at \$150 from A. Raduziner, of 332 Grand St., ostensibly for a few days. When asked to return them she refused to give them up and was arrested. In the Essex Market Police Court he was held in default of \$1,500 bail.

F. L. Farrell, who is with John Mason, 245 Fifth Ave., has a diamond on exhibition that is at present attracting much attention from those interested in rarities. The stone was mined in Kimberley, and was secured by Mr. Mason about five months ago. It is shown as it came from the mine and weighs 53 karats. Mr. Farrell thinks it will cut to 70 karats. As now seen it is a perfect octahedron.

Pawnbrokers T. Lemon, 467 Sixth Ave.; A. Silverblatt, 2317 Third Ave.; J. Stiches, 118th St. and Third Ave., and C. Bruckheimer have been placed under bail varying from \$300 to \$1,200 for accepting pledges from William Washington and Walter Clark, two young boys. The youngsters stole \$200 worth of jewelry from the former's father and pawned it with the defendants, claiming that they had been sent by Clark's sister to do so.

The auction room of Frey & Meyer, on Sixth Ave., between 15th and 16th Sts., has, it is claimed, done considerable

WE WISH TO SUGGEST

That this is about **T**he right Season
for those of the trade w **H**o have not yet purchased
from us any of th **E**well-known cuff-
buttons called the **A**nti-Swear, of which
we are the o **N**ly manufacturers,
and that are sold solely **T**o the Retail Jewelry Trade
thereby preventing ru **I**nous competition from
the Dry Goods, al **S**o other outside trades.
We
wish to call sp **E**cial attention here
to the action of the **A**nti-Swear button, which
is automatic in its wo **R**king, and which we believe
we can recommend as

THE SIMPLEST, THE MOST DURABLE AND THE MOST SALABLE
BUTTON FASTENING EVER MADE.

Examine them, try them, and satisfy yourselves.

SEND FOR A SELECTION TO

J. T. SCOTT & CO.,
4 MAIDEN LANE, NEW YORK.

injury to the business of the stores in the vicinity, the proprietors of which have complained to the Mayor. Among those who have been active in the matter is A. S. Koplík, who has a jewelry store next door to the offending auction room. Last Wednesday afternoon Secretary Speer, as the representative of the Mayor, heard the complaints, but no action was taken, the hearing being adjourned until some future date.

A strange official-appearing individual approached Secretary Condit, of the New York Jewelers' Board of Trade, last week, and after making sure of his man, thrust an ominous-looking document into the startled secretary's hands, and disappeared. From its exterior appearance the paper might have been a check, but it wasn't. It was only an invitation of a prominent member of the metropolitan government to serve as jurymen of the City Court.

The American Association of Opticians held their fourth bi-weekly meeting at the residence of Secretary Rosenblatt, 373 E. 72d St., last Wednesday evening. Frank Levison occupied the chair. After the minutes of the previous meeting had been adopted, Otto Lewin addressed the meeting on the unusual forms of ametropia which opticians occasionally witness. After other members had spoken of matters of interest the meeting adjourned.

F. C. Manvel, formerly of Ackerman, Bicker & Manvel, 6 Maiden Lane, was one of the bidders at the sale of the Brayton Ives, collection, at the American Art Galleries last Thursday. Among other things he purchased a beautiful ball of crystal 5.57 inches in diameter, supported by a bronze stand of three metal storks so posed that their heads formed the rest. In Japan a perfect crystal sphere is an object of worship and it is said the man who owns one above four inches in diameter is esteemed to be beloved of the gods. After considerable competition Mr. Manvel secured the ball and storks for \$2,800.

The suit brought by William Foerster & Co. against Gallinger & Co., dealers in glassware and bric-a-brac, to annul the credit given and for immediate judgment, was tried before Judge Patterson in the Supreme Court last Thursday and resulted in a verdict for the plaintiffs. The defendants were formerly located at 36 Barclay St., and failed in November, 1888. It was claimed that they had been guilty of fraud in the disposition of their property at the time of their failure. Evidence was given showing that Gallinger & Co., had disposed of \$30,000 of bills receivable to Mrs. Gallinger, to whom they were indebted in about \$8,600.

John Freeman, a young clerk in the employ of Melville Strong & Co., silversmiths, 3 E. Thirteenth St., last Thursday evening, endeavored to shut off the dynamo used in the electro plating, when his head touched the machinery connected with the dynamo. He stood on a sheet iron flooring and the circuit was completed. His whole form stiffened and he dropped dead to the floor.

Previous to the accident it had been discovered that the motor was out of order. The employees had been warned of this fact, but it is surmised that young Freeman had forgotten the caution and thus met his death.

Charles Heizman, last week, at No. 459 Third Ave., made an assignment to Edward C. Heizman, giving three preferences for \$1,230. The business has been established many years, and he inherited it from his mother, who died in 1881; he claimed to carry a stock of about \$10,000.

E. Koehn, Geneva, Switzerland, who recently retired from Patek, Philippe & Co., to start in business for himself, arrived from Europe last week.

J. W. Radell, of Newark, N. J., has been elected a member of the New York Jewelers' Association.

J. J. Hoff, manager of the Paris department of E. E. Kipling, arrived Sunday on *La Bourgogne*.

G. C. White, of Rogers & Bro., returned last Thursday from an extensive pleasure trip through the South.

The meeting of the creditors of Sumner Bros., which was to occur last Wednesday was adjourned until March 21.

The Holmes & Edwards Silver Co., Bridgeport, Conn., and E. H. Saxton & Co., Boston, Mass., have been admitted into membership of the New York Jewelers' Board of Trade.

J. F. FRADLEY & CO.,

Manufacturers of a General Line of

REPOUSSÉ SILVERWARE, MATCH BOXES IN SOLID GOLD AND STIFFENED GOLD,
GOLD HEADED CANES, &c.

Office and Salesroom, 23 JOHN STREET,

NEW YORK.

DORFLINGER'S AMERICAN CUT GLASS.



The Finest Crystal, Plain and Cut, made in the World.



EVERYTHING that is
used in Glass, for
the Table.



BEAUTIFUL, Artistic
and Useful Pieces
for Gifts.

Sells as well as Silver-
ware.

Rivals the Diamond for
Purity and Lustre.

EVERY FIRST-CLASS JEWELER

SHOULD KEEP IT.

C. DORFLINGER & SONS,

36 Murray Street, New York.



Fleur de Lis "VICTORIAS."

WE ARE SHOWING THE

Most Popular Line

IN THE MARKET.

H. F. BARROWS & Co.,

1½A Maiden Lane, N. Y.

CLASSIFIED INDEX TO ADVERTISEMENTS.

All Advertisements are entitled to one insertion under proper heading. Extra insertions, \$6.00 per Annum. Extra Headings \$12.00 per Annum.

	PAGE.		PAGE.		PAGE.
Assayers & Refiners.		Gold Chains.		Silk Guards.	
Baker & Co., Newark, N. J.	15	Rickert & Stiehle, Newark, N. J.	36	Rosenthal, Wm., 79 Nassau st., N. Y.	14
Goldsmith Bros., Chicago, Ill.	47	Horological Schools.		Silver Plated Ware.	
Howard, S. P., 8 John st., N. Y.	48	Chicago School of Horology, Chicago, Ill.	43	Pairpoint Mfg. Co., New Bedford, Mass.	5
Robertson & Leber, 13 Franklin st., Newark, N. J.	40	Elgin Horological School, Elgin, Ill.	14	Rogers & Hamilton Co. The, Waterbury, Conn.	48
Auctioneers.		Waltham School of Horology, Waltham, Mass.	40	Rogers & Bro., 16 Cortlandt st., N. Y.	46
Comrie, A. J., 16 West 125th st., N. Y.	33	Jewelry Repairers.		Rogers, Wm., Mfg. Co., Hartford, Conn.	36
French, J. H., Box 2775, N. Y.	35	Wiederhold, A., 20 Maiden Lane, N. Y.	10	Stem-Winding Attachments.	
Badges, Medals, etc.		Jewelers' Scales.		Abbott, Henry, 4 Maiden Lane, N. Y.	14
Stockwell, E. R., 13 John st., N. Y.	34	Troemner, Henry, 710 Market st., Philadelphia, Pa.	38	Sterling Silver Novelties.	
Black Onyx Jewelry.		Jobbers, Watches, Diamonds, etc.		Alvin Mfg. Co., 860 Broadway N. Y.	10
Woglom, Gilbert T., 32 John st., N. Y.	42	Aikin, Lambert & Co., 23 Maiden Lane, N. Y.	36	La Pierre, F. H., 18 East 14th st., N. Y.	9
Books, Stationery, etc.		Beguelin, Tell A., 71 Nassau st., N. Y.	42	Lewis Bros., 41 Maiden Lane, N. Y.	11
Chicago Envelope Clasp Co., Chicago, Ill.	11	Bowman & Musser, Lancaster, Pa.	8	Sterling Silverware.	
Dickie, W. B., 67 William st., N. Y.	34	Conover, D. F. & Co., Philadelphia, Pa.	5	Durgin, W. B., Concord, N. H.	12
Chronometers.		Cross & Beguelin, 21 Maiden Lane, N. Y.	7	Fradley, J. F. & Co., 23 John st., N. Y.	27
Heinrich, H. H., 14 John st., N. Y.	46	Friedlander, R. & L., 65 Nassau st., N. Y.	42	Gorham Mfg. Co., 10th st. & Broadway N. Y.	24
Clock Manufacturers.		Koch & Dreyfus, 22 John st., N. Y.	15	Shiebler, Geo. W., 6 Liberty st., N. Y.	14
Waterbury Clock Co., 10 Cortlandt st., N. Y.	38	Myers, S. F. & Co., 48 Maiden Lane, N. Y.	48	Towle Mfg. Co., Newburyport, Mass.	35
Cut Glass.		Scott, J. T. & Co., 4 Maiden Lane, N. Y.	26	Wallace, R. & Sons, Mfg. Co., 3 Park Place, N. Y.	6
Dorfinger, C. & Sons, 36 Murray st., N. Y.	27	Vates, John B., 147 Nassau st., N. Y.	41	Wood & Hughes, 16 John st., N. Y.	14
Phoenix Glass Co., 729 Broadway, N. Y.	15	Musical Boxes.		Thimbles.	
Diamond & Precious Stone Importers.		Jacot & Son, 298 Broadway, New York.	42	Ketcham & McDougall, 198 Broadway, N. Y.	41
Hedges Wm. S. & Co., 170 Broadway, N. Y.	39	Optical Goods.		Tool Manufacturers and Dealers.	
Kahn, L. & M. & Co., 10 Maiden Lane, N. Y.	48	Geneva Optical Co., 23 Washington st., Chicago, Ill.	36, 39, 42	American Watch Tool Co., Waltham, Mass.	47
Kipling, E. E., 2 John st., N. Y.	48	Spencer Optical Co., 15 Maiden Lane, N. Y.	2	Bullock, O. W. & Co., Springfield, Mass.	36
Kipling, R. A., 31 Union Square, N. Y.	39	Zineman, M. & Bro., Philadelphia, Pa.	12	Nordman Bros., San Francisco Cal.	40
Oppenheimer Bros., & Veith, 35 Maiden Lane, N. Y.	16	Order Work.		Swartchild & Co., Chicago, Ill.	36
Randei, Baremore & Billings, 29 Maiden Lane, N. Y.	0	Maxheimer & Beresford, 3 Maiden Lane, N. Y.	39	Typewriters.	
Smith, Alfred H. & Co., 182 Broadway, N. Y.	24	Pens, Pencil Cases, Etc.		Wyckoff, Seamens & Benedict, Broadway, N. Y.	36
Taylor & Bro., 860 Broadway, N. Y.	43	Aikin, Lambert & Co., 23 Maiden Lane, N. Y.	36	Watch Companies.	
Wheeler, Hayden W. & Co., 2 Maiden Lane, N. Y.	8	Ring Makers.		Non-Magnetic Watch Co., 177 Broadway, N. Y.	33
Diamond Cutters.		Bryant, M. B. & Co., 10 Maiden Lane, N. Y.	16, 42	Stop! Start!	40
Groenman, A. J. & Co., 80 Nassau st., N. Y.	14	Haskell, H. C., 102 Broadway, N. Y.	46	Trenton Watch Co., Trenton, N. J.	11
Diamond Jewelry.		Hildreth Mfg. Co., 51 Maiden Lane, N. Y.	10	Watch & Clock Dials.	
Bynner, T. B., 177 Broadway, N. Y.	9	Ostby & Barton, 80 Clifford st., Providence, R. I.	34	Waltham Dial Co., Waltham, Mass.	36
Falkenau, Oppenheimer & Co., 40 Maiden Lane, N. Y.	48	Rolled Plate Chains.		Watch & Clock Oils	
Ludwig, Nissen, & Co., 18 John st., N. Y.	10	Barrows, H. F. & Co., 1 1/2 A, Maiden Lane, N. Y.	27	Ginnel, Henry & Co., 31 Maiden Lane, N. Y.	11
Stern Bros., 42 Maiden Lane, N. Y.	39	Kent & Stanley, 7 Eddy st., Providence, R. I.	3	Nye, William F., New Bedford, Mass.	36
Sexton Bros. & Washburn, 41 Maiden Lane, N. Y.	39	Rolled Plate Jewelry.		Watch Keys.	
Engravers and Designers.		Crossin & Tucker, 409 Pine st., Providence, R. I.	15	Clark, A. N., Plainville, Conn.	39
Bartholomew & Peckham, 18 Spruce st., N. Y.	34	Filmerfelt, J. A. & Co., 177 Broadway, N. Y.	48	Kendrick & Davis, Lebanon, N. H.	10
Ryder & Dearth, 146 Westminster st., Providence, R. I.	38	Foster & Bailey, 60 Richmond st., Providence, R. I.	41	Watch Case Manufacturers.	
Eye Glass Holders & Chains.		Ludwig, H. & Co., Providence, R. I.	40	Essex Watch Case Co., Newark, N. J.	33
Merritt, S. F., Springfield, Mass.	12	Plainville Stock Co., Plainville, Mass.	42	Jeannot & Shiebler, 20 Maiden Lane, N. Y.	14
Fine Jewelry.		Safes and Locks.		Muhr's Sons, H., 629 Chestnut st., Philadelphia, Pa.	48
Bippart & Co., Newark, N. J.	8	Diebold Safe & Lock Co., 79 Duane st., N. Y.	44	Roy Watch Case Co., 17 Maiden Lane, N. Y.	48
Day & Clark, 10 Maiden Lane, N. Y.	38	Seal Engravers.		Wadsworth, H. A. & Co., Newport, Ky.	37
Gold and Silver Platers.		Park, William, 26 John st., N. Y.	46	Watch Case Repairers.	
Newman, Louis, Jr., 36 John st., N. Y.	9	Seamless Wire.		Feinier, G. F., 9 Bond st., N. Y.	43
Gold Jewelry.		Burdon Seamless Filled Wire Co., Providence, R. I.	42	Watch Importers.	
Carter, Sloan & Co., 15 Maiden Lane, N. Y.	4	Settings & Galleries.		Abry, Chas. L., 41 Maiden Lane, N. Y.	38
Cottle, S. Co., 860 Broadway, N. Y.	42	Blancard & Co., 36 John st., N. Y.	42	Didisheim, Hipp., 83 Nassau st., N. Y.	9
Kremenz & Co., 182 Broadway N. Y.	19	Show Cases and Fixtures.		Hydes' Sons, John E., 22 Maiden Lane, N. Y.	36
Moore & Horton, 11 Maiden Lane, N. Y.	10	Smith, B. & W. B., 220 W. 29th st., N. Y.	48	Mathey Bros., Mathez & Co., 14 Maiden Lane, N. Y.	12
Riley, J. A., & Sloan Co., 860 Broadway, N. Y.	16	Sterling Silverware.		Wittnauer, A., 30 Maiden Lane, N. Y.	7
Snow & Westcott, 3 Maiden Lane, N. Y.	7, 40	Watch Materials, &c.		Watch Repairers.	
Street, Geo. O. & Sons, 15 John st., N. Y.	11	Cross & Beguelin, 21 Maiden Lane, N. Y.	7	Juzek, Thos. & Co., Elgin, Ill.	39
		Friedlander, R. & L., 65 Nassau st., N. Y.	42	Simmonds, J. C., 18 John st., N. Y.	43
		Keller, L. H. & Co., 64 Nassau st., N. Y.	11		

Special Notices.

Rates 75c. per insertion for notices, not exceeding 3 lines; additional words 2 cents each. If answers are to be forwarded, postage stamps must be enclosed. Two insertions, 10 per cent. off; three insertions, 15 per cent. off; four insertions, 25 per cent. off. Payable strictly in advance.

Situations Wanted.

THE JEWELERS' CIRCULAR has a guaranteed circulation of over 10,000 copies weekly. It is, therefore, the best medium for reaching the trade. To demonstrate this to advertisers, notices in this column will be inserted free of charge during the month of March.

A LIVE young man of ability and experience desires position with responsible house to represent them on the road; jewelry or watches preferred; familiar with southern trade; A 1 references. Address, Salesman, care of JEWELERS' CIRCULAR.

A YOUNG MAN, aged 21, who has worked at the watchmaker's bench about two years, wants to finish the trade with a good workman; good reference; good habits. Address, N. R. H., 232 West 5th st., Hutchinson, Kansas.

BY young married man, as engraver, general workman and salesman; wages moderate; good references. Address, D. F. Lenton, Romeo, Mich.

COMPETENT book-keeper, disengaged after 3 P. M., would like employment; terms moderate. Address, H. P., care of JEWELERS' CIRCULAR.

FIRST CLASS watchmaker with twenty years' experience, wants a position in New England States; can give first-class references; German descent, four years in U. S. Address, A. L., care of E. F. Rohn, 304 Chestnut street, Milwaukee, Wis.

POSITION wanted as salesman in jewelry store; have had 5 years' experience; best of references; New England preferred. Address, H. A. Thrasher, 35 Princeton st., East Boston, Mass.

POSITION wanted with a first-class house, by practical watchmaker, with 12 years' experience at the bench. Wages expected, \$18 per week; good references. Address, Sober, care of THE JEWELERS' CIRCULAR.

Cincinnati.

D. Jacobs & Co. are about to close contracts with two more travelers.

J. C. Wilms & Son, have succeeded J. C. Wilms, at 8th & Vine Sts.

John Schweikert, of E. & J. Schweikert, says that his firm are as busy as they can be.

The betrothal of G. M. Braham and Miss Carrie Plaut, daughter of A. Plaut, is announced.

E. Shott, the 5th St. jeweler, who has been in Florida for his health for some time, writes that he is much improved.

Julius Strauss, of Strauss & Stern, is packing his grip to embark for Europe. He is going over to attend the wedding of his sister.

A. Herman will go out on a special trip in a few days. His eye-trouble is somewhat abated. Peremptory business, however, demands his presence.

John Jepson is home after a long trip, and reports very good sales up to last week, when trade suddenly lullied. He will fill up his cases and start out again.

Joseph Noterman & Co. have been kept busy with diamond work and an unusual run of repair work. The floods in the South have prevented Wm. Pfluger from going out this week.

Louis Albert is expected home from the East, early next week. His new firm are

SALESMAN wishes position in first class manufacturing house. Good trade in City, Brooklyn, N. Y. State, Phila., Balt., and Washington. Address Hustler, JEWELERS' CIRCULAR.

SITUATION wanted as traveling salesman; 12 years' experience in retail jewelry store; 28 years of age; good references; salary no object. Address, Honest, care of THE JEWELERS' CIRCULAR.

WANTED by a young man of 21, a position in a wholesale jewelry, diamond or clock house, as salesman; have 6 years' experience in a retail jewelry store; best of references given. Address, H. C. MacEwen, Jr., 522 Tremont st., Boston, Mass.

WATCHMAKER with 19 years' experience, would like a situation. Salary, \$18 per week. Can do all kinds of watch work and engrave; have all tools. Address, Conrad Kohler, Alexander, La.

Help Wanted

A FIRST CLASS watchmaker wanted; wages, \$20 per week. Send photograph and references. Address, P. H. Lachicotte & Co., Columbia, S. C.

WANTED.—A first-class jewelry salesman; one thoroughly posted in diamonds. Address, with reference, Wright, Kay & Co., Detroit, Mich.

WANTED.—One or two first-class jewelers; must be able to execute the finest grade of pearl, and other stone settings. Address, with reference, Wright Kay & Co., Detroit, Mich.

For Sale.

A FINE ship chronometer for sale cheap. Address, A. C. Taylor, Cedar Rapids, Iowa.

FOR SALE.—A complete "Audemair" trial case; new; price reasonable. Address, The J. Steinmetz Jewelry Co., Helena, Mont.

FOR SALE.—A Merritt type-writer; nearly new; price \$12. Address, G. A. Gould, Cutchogue, N. Y.

FOR SALE.—One twelve-foot, two-dial street clock, in use only fifteen months; value \$165. Will sell for \$75. In settling estate fell to disinterested party. Address "Heir," care of JEWELERS' CIRCULAR.

FOR SALE or exchange for goods, a large Herring or Terwilliger jewelry safe. Address, T. B. Bynner, 177 Broadway, N. Y.

getting their room in shape to open business They will make a specialty of American watches of all kinds.

A. G. Schwab was on the road for a few days and met with his usual success. Mr. Untermeyer, of Keller & Untermeyer, New York, was showing a fine line of decorated solid cases at Schwab's, on Saturday.

Oskamp, Nolting & Co. received a telegram on Saturday from their attorney at Elkhart, Ind., that their suit versus Chris. Arnkens and Tom Anderson, of that town, which has been pending over two years, was finally decided in their favor to the tune of \$1,100. This is quite a victory for them, as several suits have been brought against the defendants to no avail.

Norfolk, Va.

Edward Malley, of this city, had probably the greatest streak of luck in his life on Tuesday. He was eating dinner when he struck a \$75.00 pearl in a raw oyster.

Dixon Brown is improving his Main St. store.

Mr. Chapman, of Chapman & Jakeman, has been ill for about a week.

Nathan Frankfurt has received from the New Haven Clock Co. a handsome regulator with mercurial pendulum, to adorn his store.

To Let.

TO LET.—First floor back, No. 18 John street, 3 windows; possession at once if desired. Apply to Chas. Magnus.

TO LET.—One office on first floor, one on second floor, and one third floor, of Knapp Building 41 and 43 Maiden Lane, N. Y.

TO MANUFACTURING JEWELERS AND OTHERS.—A floor to let in the new improved factory building, corner St. Marks and Underhill avenues, Brooklyn. Fine light, power and all modern improvements; within twenty minutes of the Brooklyn ferries. Apply to Geo. W. Shiebler, 8 Liberty Place, New York City.

Business Opportunities.

\$2,000 IN CASH and two thousand in notes, will buy old-established and paying jewelry business near New York. Address, Wm. McAdie, with Rogers & Bro., 16 Cortlandt St., N. Y.

JEWELRY and music store in a growing town in eastern Penn.; can reduce stock to \$1,500; light position; low rent; must sell on account of poor health. Address, G. W., care of JEWELERS' CIRCULAR.

TO the benefit of our customers. We have improved our department with expert watch and jewelry repairers. Try us. All work warranted. Address M. S. Fleschman & Co., wholesale jewelers, 176 & 178 Market st., Chicago, Ill.

Miscellaneous.

W. A. SCHROETER, 108 Grand street, New York City. Estimates rendered on any desired job. Four expert watch repairers employed specially for Trade Work. Guaranteed finely finished at low prices. Also a good chance for a young man to study watchmaking.

W. F. A. WOODCOCK'S SCHOOL FOR WATCH makers, Winona, Minn., offers unrivaled facilities for acquiring a thorough practical knowledge of every branch of the business. Terms very reasonable.

WORK FOR THE TRADE.—All kinds of watch and jewelry repairing. Skillful workmen, prompt attention and satisfaction guaranteed. Address, A. W. Johanson, 176 & 178 Market st., Chicago, Ill.

Joseph Hyman, who is connected with the Jewelry Palace, has purchased fifty shares in a local real estate company.

A. C. Freeman has gone to Providence, R. I., and Philadelphia, Pa., on business.

G. B. Terrill, one of auctioneer J. H. French's assistants, who recently conducted the successful sale at A. C. Freeman's store, has gone to Pensacola, Fla., to conduct a similar sale there.

Chapman & Gale are now organizing two more clubs—one for a \$38 watch and the other for a \$50 watch or diamond.

The following salesmen were in town during the week: M. Weil, of Leopold Weil & Co., H. L. Walcutt, of H. Z. & H. Oppenheimer, G. B. Evans, of N. H. White & Co., and M. Klugherz, of M. Klugherz & Co., New York, A. B. Spear, of Champenois & Co., Newark, N. J., and George Custer, of Hollinshed Brothers, Philadelphia, Pa.

Dropped Dead at a Ball.

EVANSVILLE, Ind., March 11.—Henry Schwartz dropped dead to-night while attending a dance. He was about 50 years old, and leaves a wife. He was a captain in the Confederate army.

The deceased was formerly in business in Cincinnati, O. He started in Evansville in 1885. In addition to his jewelry business, he conducted a pawn-broking establishment.

VALUABLE INSTRUCTION BOOKS

FOR SALE BY

THE JEWELERS' CIRCULAR PUBLISHING CO., 189 Broadway, N. Y.

Goldsmiths' Handbook, containing full instructions for the Alloying and Working of Gold. By GEO. E. GEE. Price, post-paid, \$1 20

Silversmiths' Handbook, containing full instructions for the Alloying and Working of Silver. By GEO. E. GEE. Price, post-paid, 1 20

Practical Instruction in the Art of Letter Engraving. By G. F. WHELPLEY. Price, post-paid, 2 00

Kemlo's Watch Repairer's Handbook. Illustrated. For beginners and advanced workmen. By F. KEMLO. Price, post-paid, 1 25

Watch and Clock Making (with 6 diagrams). By DAVID GLASGOW, President of the British Horological Institute. Price, post-paid, 2 00

Treatise on Watch Work, Past and Present. By the Rev. H. D. NELTROPP, M. A., F. S. A. Numerous Illustrations. Crown, 8vo, cloth. Price, post-paid, 2 50

Treatise on Modern Horology in Theory and Practice. By M. CLAUDIUS SAUNIER. Translated by JULIEN TRIPPLIN, Besancon Watch Manufacturer, and EDWARD RIGG, M. A., Assayer in the Royal Mint, London. Price, 15 00
This valuable work comprises 812 large octavo pages, with 78 Wood Cuts and 21 colored double-page, copper-plate Engravings, is printed on excellent paper and bound in half calf, with a handsome and appropriate ornament in gold on front cover.

Watch and Clockmaker's Handbook, Dictionary and Guide. 1889 Edition. Revised. By F. J. BRITTEN. Price, post-paid, 2 00

Watchmaker's Handbook. Latest edition, revised and enlarged. Same Author and Translator, and intended as a Companion to the Treatise. Illustrated by 14 double-page Copper-plate Engravings and numerous Wood Cuts; cloth cover. Price, post-paid, 3 50

Handbook for Opticians. By W. BOHNE. Illustrated. Price, 2 50

Detection and Correction of Visual Imperfections. (With Test Type.) By Dr. C. A. BUCKLIS, A. M., M. D. Price, post-paid, 1 00

The Watch Jobber's Handy Book. A Practical Manual on Cleaning, Repairing and Adjusting Watches; with Information on the Tools, Materials, Appliances and Processes employed in Watchwork. By PAUL N. HASLUCK. 100 Illustrations, 0 80

The Clock Jobber's Handy Book. A Practical Manual on Cleaning, Repairing and Adjusting Clocks; with Information on the Tools, Materials, Appliances and Processes used in Clockwork. By PAUL N. HASLUCK. 100 Illustrations, 0 80

Prize Essay on the Balance Spring and Its Technical Adjustments (Baroness Burdette Courts' Prize). By M. IMMISCH. Cuts, crown, 8vo, cloth, 1 00

A Handbook of Precious Stones. By M. D. ROTHSCHILD. Cloth. Illustrated, 1 00

Electrolysis; a Practical Treatise on Nickeling, Coppering, Gilding, Silvering and Refining of Metals and Treatment of Ores by Means of Electricity. By H. FOXTAINE. With 34 Illustrations, 3 50

Electro-Plating. A Practical Handbook on the deposition of Copper, Silver, Nickel, Gold, Aluminum, Brass, Platinum, etc.; with descriptions of the Chemicals, Materials, Batteries and Dynamo Machines used in the Art. By J. W. URBHART, 2 00

Electro-Deposition; a Practical Treatise on the Electrolysis of Gold, Silver, Copper, Nickel and other Metals and Alloys, with Descriptions of Voltaic Batteries; Magnets and Dynamo-Electric Machines; Thermopiles, and of the Material and Processes used in every Department of the Art and Several Chapters on Electro-Metallurgy. By A. WATT. 3 50

The Metallic Alloys. A Practical Guide for the Manufacture of all kinds of Alloys, Amalgams and Solders used by Metal Workers, together with their Chemical and Physical Properties and their Application in the Arts and the Industries; with an Appendix on the Coloring of Alloys. From the German of A. Krupp and Andreas Wildberger. Illustrated by 16 Engravings. 2 50

A Treatise on the Transit Instrument as Applied to the Determination of Time. By LATIMER CLARK, M. I. C. E. 2 00

Manual of the Transit Instrument, as used for obtaining Correct Time. By LATIMER CLARK, M. I. C. E. 40

Turning Lathes. A Manual for Technical Schools and Apprentices. A Guide to Turning, Screw Cutting, Metal Spinning, etc. 194 Illustrations. Edited by JAMES LUKIN, B. A. 1 00

Workshop Receipts for the use of Manufacturers, Mechanics and Scientific Amateurs. By ERNEST SPON. 2 00

Gems and Precious Stones of North America. By GEO. F. KUNZ. A popular description of their occurrence, value, history, archeology, and of the collections in which they exist; also a chapter on Pearls. Illustrated with 8 colored plates and numerous minor engravings. 10 00

ALL PRICES PAYABLE IN ADVANCE.

As a special inducement to new subscribers, we make the following offer :

Add **One dollar** to the price of any book in this list, and we will send it with THE JEWELERS' CIRCULAR for **One Year**. The regular price of THE CIRCULAR is Two dollars.

OR

We will send The Circular for six months on trial for Fifty Cents.

OR

For Two dollars, we will send it for **One Year** and a copy of any of these three books free :

DICKIES' IMPROVED WATCH REPAIR BOOK, containing 100 pages, ruled for full record of all repairing handled.

DICKIES' IMPROVED WATCH STOCK BOOK, same as above, but ruled for purchase and sales of Watches.

DIETZ' BOOK OF MONOGRAMS, containing over 3,000 monograms for the engravers' use. This book is indexed, so you can find any combination in ten seconds' time.

OUR CLUBBING LIST.

New subscribers (not renewals) can secure THE JEWELERS' CIRCULAR at a much cheaper rate by ordering their other publications through us. The following are some of our clubbing rates. Rates on any other papers will be furnished on application:

	Regular Price.	With the JEWELERS' CIRCULAR.		Regular Price.	With the JEWELERS' CIRCULAR.
Century Magazine,	\$4.00	\$4.50	Harper's Young People,	2.00	2.50
St. Nicholas,	3.00	3.50	Harper's Magazine,	4.00	4.00
New York Ledger,	2.00	2.50	Frank Leslie's Illustrated		
Harper's Weekly,	4.00	4.25	Weekly,	4.00	4.25
Harper's Bazaar,	4.00	4.25	Judge,	5.00	5.00
Youths' Companion,	1.75	2.50	Life,	5.00	5.25

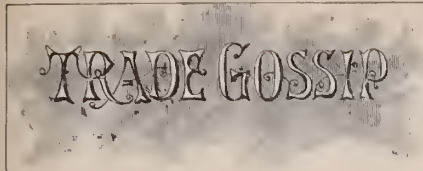

T. G. Walpuski, manager of the American Morocco Case Co., 9 Bond St., New York, has just returned from a very successful trip to the far West.

Jules Racine, of the watch-importing firm of Jules Racine & Co., 1 Maiden Lane, New York, has gone on a short business trip to Chicago and the West.

All jewelers who handle spectacles should read the advertisement of Bowman & Musser, Lancaster, Pa., in this issue. Inducements are offered which they cannot afford to miss.

Peter Henry says he has a great many old English watches to Americanize every week or so. He comes across a great variety of old makes and some very curious cases fall into his hands.

A firm that is making rapid headway in the trade is Bippart & Co., of Marshall St., Newark, N. J. The new goods being manufactured by this firm for the coming season include many novel and salable articles.

Mathey Bros., Mathez & Co., 16 Maiden Lane, New York, are the headquarters for timing and complicated watches. This firm manufacture the major portion of their varied stock and they know just what is wanted by the trade.

H. Ludwig & Co., Providence, R. I., claim to be the largest manufacturers of hoop earrings in the United States. They have had fitted at their factory improved machinery of great capacity, and are prepared to fill all orders promptly.

Strauss & Stern, Cincinnati, are known as one of the best houses to get emblem goods. They keep the latest and best and renew every week. Leo Strauss is noted for a determination to keep a full hand. The boys are sending in their quota.

R. & L. Friedlander, of 65 Nassau St., New York, are at present making a specialty of their Monarch American mainsprings. They also deal in all the articles required by watch makers and jewelers and will on receipt of business card send a catalogue of their goods.

H. M. Smith & Co., 83 Nassau st., have removed to an elegant suite of offices on the second floor of the same building, where they will have more room for their increasing business. They are now pushing their business as jobbers in American watches with much success.

With the opening of the spring comes the demand for fancy store rings, and jewelers should be prepared to meet it. Hayden W. Wheeler & Co., of 2 Maiden Lane, New York, are now showing a most extensive line in this class of goods. Moonstones, topaz, garnets, pearls, and many other varieties are seen mounted in many desirable patterns.

Jos. Noterman & Co., Cincinnati, have a large line of diamond and fancy stone rings. Their new designs in opals are magnificent. Wm. Pfluger will carry a fine assortment on his next trip. He declares that moonstone scarf pins and rings will sell over anything else. For frosted work there is no house that can turn out handsomer pieces. Mr. Noterman is noted for experiments, some of which have resulted in fine discoveries.

One of the most diabolical inciters of forcible language is a cuff button which fails work. Men will spend more time swearing at a cuff button during one year than they will devote to religious subjects for the remainder of their natural life. Why it is so, it is hard to imagine when a contrivance like the Anti-Swear button, manufactured by J. T. Scott & Co., 4 Maiden Lane, New York, makes it a perfect pleasure to adjust one's wrist coverings.

A production that promises to revolutionize the thimble trade is that advertised in another column by Ketcham & McDougall,

198 Broadway, New York. It is a thimble made of aluminum. The advantages which this metal possesses are its cheapness, durability and lightness. Unlike silver it will not tarnish or discolor the hand and always presents a surface both hard and bright. By mentioning THE CIRCULAR and enclosing business card any jeweler can obtain samples and prices.

One of the latest patterns in cut glass is the "Crescent," which consists as its name suggests of a series of crescents all cut in the same direction. The Phoenix Glass Co., 729 Broadway, New York, are the exclusive manufacturers of this design. The "Olympic" and the "Prussian Bead" are other 1891 cuttings made by this company that promise to attract much attention. They are produced in scores of articles from a small dish to an arc-electric light globe, and will prove profitable stock for jewelers to handle.

The number of cuts and electrotypes made for the manufacturing jewelers of Providence, the Attleboros and environs, would

KREMENTZ & Co.,

182 & 184 Broadway, NEW YORK,

MANUFACTURERS OF

GOLD JEWELRY,

14-K. BEAD NECKLACES,

— AND —

KREMENTZ ONE-PIECE COLLAR BUTTONS.

LEON J. GLAENZER & CO.,

80 CHAMBERS STREET,

35 Boulevard de Strasburg,
PARIS.

NEW YORK.

OUR SPECIALTIES:

Clocks, Porcelains, Faiences, Bronzes.

We have now on exhibition and are constantly receiving large shipments of the latest novelties in **Onyx and Marble Clocks**, with Gilt and Enamelled Trimmings, **Regulators, Traveling Clocks, Porcelain and Gilt Mounted Clock Sets, Vases, Candelabras, etc.**, which we are offering at Lowest Prices.

Our stock also comprises a large assortment of **Porcelains, Faiences, Bronzes, Gilt and Silver Photo Frames, Jewel Boxes, Bonbonnières, Mirrors, etc.**, suitable for the jewelry trade.

SPECIAL INDUCEMENTS ON IMPORT ORDERS.

astonish those not accustomed to their use. Some idea of the volume of this trade may be gained by the fact that the Ryder & Dearth Co., 146 Westminster St., Providence, R. I., have a special department devoted to cuts and electros for jewelers, which is kept constantly busy on this work. As the oldest and foremost firm in New England, who cater specially to cuts, electros and printing for jewelers, the concern have become so well known to the trade by the quality of their work and low prices as to make it scarcely necessary to call attention to their advertisement on another page.

M. B. Bryant & Co., the ring makers of 10 Maiden Lane, New York, are pushing their facilities to the utmost to supply the demand for their new birthday rings in patent trays. The novelty of the idea and the popularity of birthday rings among young misses in all parts of the country insure a large sale for the "Bryant Birthday Rings."

The new eighteen size movement recently placed on the market by the Trenton Watch Co. has been received exceedingly well by the trade, and the company are already behind in their orders. By an arrangement made by the company many jobbers in the National Association have this new movement, through whom the retail trade can be supplied.

This is the season when retail jewelers replenish their stock of clocks, bronzes and fancy articles to meet the demand for wedding presents. Leon J. Glaenger & Co., 80 Chambers St., New York, have just imported a large variety of jewel caskets, hand mirrors, silver filagree goods, clocks, etc., and are able to quote prices that cannot fail to please.

The stock of timing and repeating watches now being shown by A. Wittnauer, 30 Maiden Lane, New York, for the coming season, is complete in every particular. One of the many advantages offered by timing watches is the accuracy and reliability under all circumstances. Reputable firms can obtain samples of these goods on memorandum by mentioning THE CIRCULAR.

In calling attention to the advertisement of the Diebold Safe & Lock Co., on page 44, we take occasion to say, that at their works special attention has been given to the construction of safes for the protection of the valuable stocks of jewelers from loss by fire or burglars. The former protection is offered in their regular safes, and for jewelers' use they make, however, a combined fire and burglar-proof safe. Plates of five-ply Chrome steel are used in constructing these safes, and many of the improvements used in their celebrated bank vault and safe work are used also in their safes for jewelers' use. W. H. Butler, the agent for this company, has a remarkably long list of jewelers, who have already been supplied with their fire and burglar-proof protection.

Whittemore & Woodsome, Waltham, Mass., have disposed of their business to W. L. Rugg.

Louisville.

John Baker, of H. W. Wheeler & Co., New York, was in the city last week and gave a box party to a number of friends.

P. Melcher, of Shoemaker, Pickering & Co., J. D. Underwood, of Champenois & Co., J. E. Simonson, of A. J. Hedges & Co., and C. F. Ketchum, of Wm. Riker, Newark, N. J., J. Watson, of Reed & Barton, Taunton, Mass., and N. Wolff, of Veit Hirsch & Co., New York, were in town last week.

Rodgers & Pottinger have added a manufacturing and repairing department to their establishment, which will occupy the third floor of their building over the store; complete facilities have been received, and the factory will be one of the completest of its kind in this part of the country. Two of the leading jewelers of this city have established in the rear of the stores art rooms which are open at all times to the public. These rooms exhibit costly and elegant things in the jewelry, figures, clocks, vases, rare china and bric-a-brac of all sorts.

Pacific Coast Notes.

H. Etling, the Los Angeles auctioneer, is selling the fixtures and stock of M. M. Lowenthal, of that city, by order of the creditors.

W. B. Clifton, formerly with W. K. Vanderslice & Co., of San Francisco, has taken charge of W. C. Durno's jewelry store, Truckee, Nevada.

A fire at Junction City, Ore., destroyed the store of F. W. A. Crain, involving a loss to store and fixtures of \$10,000. Mr. Crain's insurance amounted to only \$4,500.

At Selma, Cal., a magnificent clock at the National Bank has been guilty of playing leap year, and by giving February twenty-nine days made itself a day behind time with its calendar register.

A Nevada paper is guilty of the following unique comment: "It is estimated that more than eight tons of diamonds have been unearthed in South Africa, valued at \$275,000, during the last eighteen years, and still, drummers and hotel clerks persist in wearing the ninety-nine-cent article."

Late Newark Notes.

J. A. Lebkecher, of Kremenz & Co., is sojourning in Florida. He is accompanied by his wife and the Misses Lulu and Anna Kremenz.

Officer Chas., Wolfarth, of Halme & Co's establishment, arrested Henry Dresse, the assistant engineer of the place on Saturday, charging him with theft. Dresse who is 19 years of age, is accused of having stolen a half dozen diamond scarf pins and studs from the jewelry counter; the articles were found in his pockets. He was brought before Justice Rodrigo to whom he said that the stolen pins, were put in his pocket by some one else, as he had no knowledge of their being there. Dresse was bailed by his father.

The Gorham Mfg. Co. will not Change their Business.

In reference to the various rumors that have been circulated, evidently by irresponsible parties, that a sale of the Gorham Mfg. Co.'s business had been or was about to be made, THE CIRCULAR, recently sent a representative to the office of the company who was authorized to state that the Gorham Mfg. Co.'s business has not been, and will not be sold out to any English syndicate.

The representative of the company who was seen, expressed his satisfaction at having an opportunity to publish the denial through the columns of THE CIRCULAR. He added that there are no changes whatever contemplated in the management of the Company, except possibly, such as may develop from the growth of the business and the necessity for an enlarged organization.

The Week's Arrivals.

The following dealers from out of town are registered in New York, during the current week: H. E. Hall, buyer for Forbes & Wallace, Springfield, Mass., No. 120 Franklin St.; F. J. Faust, Allentown, Pa., Morton House; F. W. Knowlton, Worcester, Mass.; A. La France, Elmira, N. Y., Astor House; H. Ellis, Toronto, Can., Astor House; J. Hass, Chicago, Ill., Astor House; A. Smith Chicago, Ill., Astor House; W. Hennegen, of Baltimore, Md.; Mr. Tilden, of Tilden, Thurber & Co., Providence R. I.; N. H. Brown, Boston, Mass., Metropolitan Hotel; M. Strauss, buyer for L. H. Holzheimer & Co., Elmira, N. Y., 375 Broadway; L. Reigler, Attica, N. Y., Earle's Hotel; R. Holland, Montreal, Can., Continental Hotel; J. W. Plummer, Boston, Mass., Grand Union Hotel; S. Berwanger, Raleigh, N. C., Union Square Hotel; J. Karr, Washington, D. C., St. Denis Hotel; G. F. Blake, Jr., Boston, Mass., Windsor Hotel; F. D. Enney, Syracuse, N. Y., Bartholdi Hotel; J. Drach, buyer for Ruff & Drach, Chicago, Ills., Gilsey House; S. S. Saxton, Springfield, Mass.; J. Brown, Boston, Mass., Grand Union Hotel; E. W. Fox, Boston, Mass., Astor House.

Transatlantic Passengers.

Among the jewelers who sailed to Europe last week were S. W. Doty, G. F. Galt, A. Herrman, A. J. Prager and M. Prager, on the *Teutonic*; Leopold Adler on the *Rhyland*; Frederick Goldsmith, A. Krower, E. F. Oppenheimer, on the *Lahn*.

The arrivals were C. S. Powell and J. G. Hyde, on the *Etruria*.

A. L. Hyde, Hill City, S. D., has placed his stock in a local bank and left for the East. It is supposed that he has gone to Chicago.

Ex-Councilman Preston Ayars, of Wilmington, Del., a member of the jewelry firm of Ayars & Son, died yesterday, aged fifty-two years. He leaves a wife and two children.

Recent Patents

Issue of March 10, 1891.

DESIGN No. 20,576 HANDLE FOR SPOONS, ETC. WILLIAM A. BATES, Winchester, Mass.—Application filed January 24, 1891. Serial No. 378,078. Term of patent, 7 years.

DESIGN No. 20,580. BADGE. CHARLES B. MELROY AND THOMAS W. MINSHALL, Cleveland, Ohio.—Application filed January 19, 1891. Serial No. 378,362. Term of patent, 7 years.

DESIGN No. 20,570. ORNAMENTATION OF GLASSWARE. JOHN BILLARD, Honesdale, Pa., assignor to T. B. Clark & Co., same place.—Application filed February 3, 1891. Serial No. 380,092. Term of patent, 14 years.

447,761, SPECULUM. WILLIAM E. CLOUGH, Oxford, Ohio.—Filed June 23, 1890. Serial No. 356,319. (No model.)

447,782, BUTTON. ADOLF MANDEL, New York, N. Y.—Filed Nov. 26, 1890. Serial No. 372,731. (No model.)

447,855, SEPARABLE BUTTON. WILLIAM F. WHITING, Providence, R. I., assignor to Hiram Howard and Stephen C. Howard, same place.—Filed June 28, 1890. Serial No. 357,078. (No model.)

In a separable button, the combination of a head or front having an attached tubular, post-section notched at the forward end, spring-arms fitted in the post-section



tion and provided with notches 1 and projections 2, 3, bolts a⁶, whose outer ends work through holes provided in a cap-plate which is comprised in the head 01 front and whose inner ends coast with the projections 2 of the spring-arms, projections a extending from the bolts, a ring a⁸, placed rearward of the bolts and having notches for receiving the projections a⁷ thereof, and a back-plate having a tubular post-section b, provided with holes b² for engaging with the projections 3 on the spring-arms.

447,879, SUSPENSION DEVICE FOR PENCIL-CASES, ETC. JOHN C. W. JEFFREYS AND GEORGE DICKMAN, London, England assignors to George W. Mabie, Brooklyn, N. Y.—Filed June 7, 1890. Serial No. 354,549. (No model.) Patented in England Feb. 2, 1889, No. 1,897.

447,908. WATCH-CASE PENDANT. BERNHART SCHIFF AND LOUIS MAVER, New York, N. Y.—Filed Aug. 28, 1890. Serial No. 363,324. (No model.)

The combination, with the watch-case stem and the band secured thereon in rotary adjustment and provided with diametrically-opposite perforations having enlarged inner portions, of a watch-bow having its ends projecting within the perforations in the band and having its inner ends upset, and a seat-washer located within the enlarged portions of the perforations in the band between the upset ends of the band and the bases of such enlarged portions.

447,973, REPEATING WATCH. BERNARD REBER, Locle, Switzerland.—Filed June 30, 1890. Serial No. 357,232. (No model.) Patented in Switzerland Nov. 23, 1888, No. 102.

In repeating-watches, the combination, with the lever A, having a pin b, and its pivot a near the center of the watch, of an arm C, pivoted to the lever A at c

ARE YOU DISSOLVING PARTNERSHIP
 ARE YOU HAVING DULL TRADE
 ARE YOU ABOUT TO RETIRE
 ARE YOU OVERSTOCKED
 ARE YOU REMOVING

IF YOU ARE, COMMUNICATE WITH

A. J. COMRIE,
 AUCTIONEER,

Specialty of Jewelers' Sales. 16 West 125th St., New York.

WE DESIRE to call your attention to our large and varied assortment of

Complicated, High Grade Gentlemen's and Ladies'



In Gold Cases, both Plain and Enameled, in Choice Designs.

THE LARGEST STOCK EVER SHOWN IN THIS COUNTRY.

NON-MAGNETIC WATCH CO.

OF AMERICA.

CHAS. MCCULLOH, RECEIVER

177 Broadway. - - NEW YORK.

Essex Watch Case
 COMPANY,

T. B. HAGSTOZ, President.



6 Maiden Lane, N. Y.

OFFICE,

NEWARK, N. J.
 FACTORY,

GOLD FILLED CASES.

BOOKS FOR JEWELERS.

W. B. DICKIE,

67 William Street, New York,

PUBLISHER OF

Improved Watch Stock Book

—AND—

Improved Watch Repair Book.

SEND FOR DESCRIPTIVE CIRCULAR.



E. R. STOCKWELL,

MANUFACTURER OF

BADGES AND MEDALS

IN GOLD
AND SILVER,

FOR ALL SOCIETIES,
INCLUDING

MASONIC
ODD FELLOWS,
GRAND ARMY.

Also for Schools.

BUTTON BADGES
IN SILVER OR GOLD.

Enameling and Repairing
for the trade.

19 John Street, N. Y.

Diamond Mounting. - Engraving. - Order Work.

E. R. STOCKWELL
19 John Street,
NEW YORK.



ZIP!



Revolve these Rings in your mind, and you cannot help thinking of **OSTBY & BARTON**, the well known ring makers, 80 Clifford Street, Providence, Rhode Island.

AIKIN, LAMBERT & Co.,

23 Maiden Lane,
NEW YORK,

Manufacturers and Exporters of

Fine Gold Pens, Pencils,

TOOTHPICKS, HOLDERS,
And Novelties in Silver, Pearl, &c.



THE BEST FOUNTAIN PENS.

New Assortments in SHOW CASES and FANCY TRAYS for JEWELERS.
Price Lists and Catalogues for intending Purchasers.



Also American and Swiss Watches.

DIAMONDS, Loose and Mounted,

Gold and Silver Thimbles,

CHAINS and JEWELRY in New and Staple

SWARTCHILD & CO.,



Our Complete Catalogue, illustrated, will be sent to any one forwarding us their address, free of charge.

We give special attention to mail orders. They are filled promptly the same day that they are received.

76 and 78 State Street, Chicago.

Jules Jürgensen

OF COPENHAGEN.

The reputation these watches have maintained for **Fifty Years** has never been equalled, being made on strictly scientific principles, and no expense spared to give the **Best** results in mechanism and timekeeping qualities

SOLE AGENTS.

John C. Hyde's Sons,
1 No. 22 MAIDEN LANE.

WATCH DIALS.

Any kind watch dial duplicated within ten days. Factories supplied with dials for their entire product or with special designs for their high grade movements. Special rates for large quantities. Emblems, photographs, landscapes and ornamental work of every description on plain, enamel or under glaze.

WALTHAM DIAL CO.,
WALTHAM, MASS.

A. RICKERT. C.A. STIEHLE.
RICKERT & STIEHLE,
MANUFACTURERS OF
GOLD CHAINS,
SWIVELS AND SPRING RINGS.
Chain Repairing a Specialty.
13 & 15 Franklin Street. NEWARK, N. J.

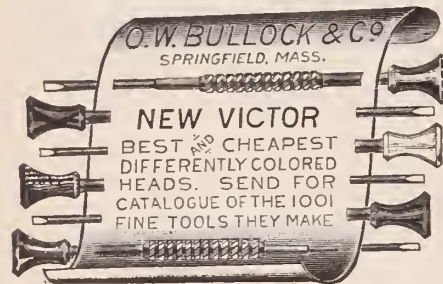

THE FINEST
Watch
AND
Clock
Oil
MADE.

W.F. NYE
Superfine
WATCH OIL.
New Bedford NONE GENUINE
Mass. WITHOUT MY SIGNATURE
U.S.A. MY SIGNATURE

W.F. NYE
Superfine
CLOCK OIL.
New Bedford NONE GENUINE
Mass. WITHOUT MY SIGNATURE
U.S.A. MY SIGNATURE



Geneva Optical Co.,
MANUFACTURERS OF
Spectacles, Eye
Glasses, Lenses
and Cases.
23 WASHINGTON ST.,
CHICAGO.

The Highest Grade — OF — Electro Silver Plated Ware

Is Stamped with the



ROGERS TRADE-MARKS.

MANUFACTURED BY

The Wm. Rogers Manufacturing Co.,
P. O. DRAWER 30,
HARTFORD, - CONN.



The Remington

has set the copy for writing machines for 15 years. It is to-day the

Standard

and expects in the future, as it has in the past, to lead all others in adding improvements to what will always be the true model of a

Typewriter.

W. J. Coff, Seaman & Benedict,
327 Broadway, New York.



off. Some of the lighted, black deposit may also pass away. Let it go, as it contains no silver. If it is summer the stoning should be set out in the sun to dry. If it is winter, it should be dried with artificial heat. When thoroughly dry it should be glow-heated in appropriate pans. This process is to be recommended because the mass becomes very much concentrated thereby. Then take for each six pounds of stonings three and one-half pounds of pure nitric acid, of the usual strength. Place the stonings in a large stone or earthenware vessel, and fill the vessel not more than half full. Pour upon the stonings the indicated weight of nitric acid and cover the vessel.

After twenty-four hours pour in enough hot water to reduce the stonings to a thin paste. Leave the vessel in this condition until the yellow vapors cease to be evolved. When they have stopped pour in more hot water until the vessel is full. When the stoning has deposited again and the water is clear, carefully decant it into another vessel, in which the precipitating with copper will subsequently be performed. Wash the stoning three or four times; in fact, until it contains no trace of silver, which can be recognized if from time to time a few grains of salt are thrown into the clear water during the process of washing. After the sediment has deposited, it may be presumed that all the silver has been washed out if the salt dissolves without a white cloud. Pour together the first and second decantings, which

contain the largest quantities of silver, and precipitate the latter with copper. It is advisable to take long strips of copper for this purpose, since they are more commodious and can be simply set in the vessel, thus rendering the process of the crystallization of the silver more easily observable. Clean the strips from time to time. If none are at hand, however, take a sheet of copper, perforate it in suitable places, draw a cord through. Tie this to a piece of wood and suspend the plate in the liquor, laying the piece of wood across the vessel.

As was previously said, the first and second decantings contain the greatest amount of silver, which is precipitated with copper, the process being finished in twenty-four hours. The water over the silver must be poured off and the latter washed a few times with warm water. Although the largest quantity of the silver has been obtained in this manner, still the other wash waters also contain a small percentage. But the copper precipitation process would be too slow, and it is best, therefore, to use common table salt. Wash the stoning a few more times with warm water until the few grains of salt thrown in show no cloudiness whatever. Do not hurry the operation. Throw a quantity of salt into the collected washwaters, stir them well, and let them stand for twelve hours. A white deposit, chloride of silver, or horn silver, will have collected on the bottom, and the water will have become clear. The process may then be regarded as

finished. For the sake of satisfying yourself that all the silver has been recovered, throw in a few more grains of salt. If the water remains clear, as well as the stoning, it may be thrown away. The reduction into metallic silver is known to every silversmith.

Future Opticians.

MANY opticians of Chicago and other cities are taking a course at the Chicago College of Ophthalmology and Otology, and are greatly benefited. The optician's course lasts a month, during which time special instruction is given to those who desire to become practical opticians. One course closed February 10th, the graduating class being Seymour T. Baker, Webster Bliss, Elmer A. Thorp, and A. W. Vincent, of Michigan; Will F. Bundy, R. C. Burton, Mrs. L. Brown, M. A. Dearlove, Charles C. Edson, H. F. Hilderbrand, Baxter O. How, W. K. Leland, Wm. J. McCray, Charles A. Miner, Garton, Nichols, Ezra Peters, B. I. Poland, J. F. Rennert, A. L. Sabin, John Struble, H. S. Tucker, F. E. Thornton, and Florence Ziegfeld, of Illinois; L. D. Bailor and E. W. Fall, of Nebraska; T. J. Batchelder, of Maine; O. M. Blood, D. D. Crowley and N. N. E. Wood, of New York; Arthur L. Blunt, C. C. Harris, M. H. Stetson and R. H. Stetson, of Wisconsin; Wm. L. Busby, Frank Cornwall, C. B. Edmunds, F. B. Hoffmeyer, and Allen E. Stevens, of Iowa; Lyman W. Denton and Hans J. Eng-

H. A. WADSWORTH & CO.

MANUFACTURERS OF

GOLD · FILLED · WATCH · CASES,

NEWPORT, KY.

lund, of Minnesota; Charles S. Dwyer, of Pennsylvania; Blair Haggerty, of Ohio; H. L. Hockensmith, of Missouri; B. F. Josselyn and D. McLennon, of California; Edward Osborn, and Charles L. Van Doren, of Ontario; John H. Herring, John A. Ryan, of Indiana; Edgar Towl, of Oregon, and others.

The college was founded in 1878 by Dr. Henry Olin, and has been a success from the start. Dr. Olin died in Florida in January. The faculty of the college is composed of B. A. Camfield, Dean and Professor of Diseases of the Eye and Clinical Ophthalmology; Dr. S. Tucker, Professor of Diseases of the Ear, Nose and Throat and Clinical Otolaryngology; Dr. H. L. McIntosh, Professor of Special Ophthalmic and Aural Microscopy; Dr. A. Willard, Professor of Special Anatomy and Physiology; Dr. W. S. Hector, Professor of Refraction, Accommodation and Optics; H. L. De Zeng, Jr., Assistant Professor of Special Ophthalmic and Aural Microscopy. The college, which is incorporated, is located at 78, 80, and 82 State street.

A Complete History of Watch and Clock Making in America.*

BY CHAS. S. CROSSMAN.
Number Fifty-two.

Continued from page 54, Feb. 4.
GIDEON ROBERTS.

THIS old clockmaker was the first man to make wooden clocks in Bristol, and as we have already said one of the first to make them in Connecticut. He was born in 1769, according to the date on the tombstone in the Old Downes cemetery in Bristol. His father's family, together with forty other families from Connecticut, settled in Wyoming Valley, Pennsylvania, in 1775, and Gideon, of course, accompanied his parents.

In the historical Wyoming massacre which occurred in 1778 the elder Roberts was killed, leaving his wife with a large family. The woman walked back to Connecticut taking her children with her, and carrying her

*Copyright 1835 by C. S. Crossman.

youngest child in her arms. Of Gideon we know nothing further until he appears as a maker of wooden clocks in Bristol in 1790. He lived at this time in a house in Bristol now occupied by Asher Bailey. Here he made his clock movements which were of the usual "hang up" style of that day. The plates were of oak and half an inch thick and a foot square. He turned and whittled the pinions into shape and sawed the teeth out by hand; the weights were tin canisters filled with shot or gravel when the clock was set up, and they were wound by pulling down a cord which wound up again as the weight ran down. These clocks were worth \$25 each.

Chauncey Jerome in his "American Clock Making," published in 1860, says (page 38): "Sixty years ago a man by the name of Gideon Roberts got up a few in the old way (referring here to the sawing and whittling methods which he had previously described), he was an excellent mechanic, and made a good article, would finish three or four at a

**VACHERON & CONSTANTIN,
GENEVA, SWITZERLAND.**



FINEST QUALITY OF WATCH MOVEMENTS, FITTING
ALL SIZES OF AMERICAN CASES.



CHAS. LEO ABRY,

Agent for the United States and Canada.

41 and 43 Maiden Lane, - - - NEW YORK.

DAY & CLARK,
MAKERS OF
FINE JEWELRY,
BEAD NECKS AND BEAD BRACELETS
CURB AND LINK BRACELETS
STRICTLY 14 KT.
10 MAIDEN LANE N. Y.

HENRY TROEMNER,
No. 710 Market Street, PHILADELPHIA.

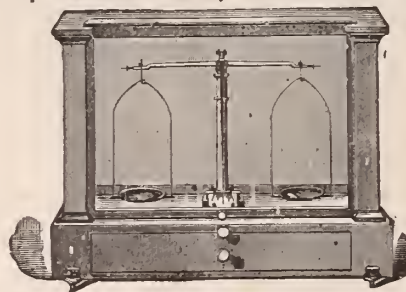

Manufacturer of FINE GOLD SCALES and DIAMOND SCALES
Bullion Balances and Weights, in use at all the U. S.
Mints and Assay Offices. Priced Catalogue on application.

THE RYDER & DEARTH,
DESIGNERS & ENGRAVERS
Fine Commercial and Copper-Plate Printers.
A Specialty of
Jewelers' Printing, Cuts and Electrotypes.
Headquarters for JEWELERS' CARDS.
BEST WORK, PROMPT DELIVERY, LOW PRICES.
No Order Too Large! None Too Small!
146 Westminster Street,
PROVIDENCE, - RHODE ISLAND.

**WATERBURY CLOCK CO.,
CLOCK MANUFACTURERS.**

SALESROOMS:
10 Cortlandt St., New York,
GEO. M. VAN DEVENTER AGENT.

SALESROOMS:
114 & 116 Wabash Avenue,
CHICAGO,
H. S. PECK, AGENT.

SALESROOMS:
528 & 530 Market Street,
SAN FRANCISCO.
A. I. HALL & SON, AGENTS.

FACTORIES:
Waterbury, Conn.

123 Stockwell Street, Glasgow,
T. R. DENNISON, AGENT.

time and take them to New York State to sell. I have seen him many times when I was a small boy pass my father's house on horseback with a clock in each of his saddle-bags and a third lashed on behind the saddle with the dial in plain sight. Mr. Roberts had to give up this kind of business as he could not compete with machinery." Mr. Jerome certainly should be considered a good authority as to the manner in which these clocks were made, but certain parties have spoken of the sawing and whittling as imaginary but if the writer may be allowed an opinion it is, that Mr. Roberts had no machinery or power and did all the work by hand and in the manner described. Just when he gave up clock-making we do not know, but he died in Bristol on June 20th, 1813. His clock No. 37. was on exhibition at the Centennial of Bristol, held June 17th, 1885, where the writer had the privilege of inspecting it.

JAMES HARRISON AND WILLIAM LEAVENWORTH.

So far as history and tradition both bear on the subject, James Harrison was the first clock maker in Waterbury. We do not find that he ever served an apprenticeship. He was born in Litchfield, Connecticut, about 1760.

We are not entirely at the mercy of legends, however, as the historian of Waterbury has carefully gleaned some facts concerning Mr. Harrison which we copy. "James Harrison began to make wooden clocks by hand in a lower room of the Academy which stood near the south end of what is now the Green. He had previous to this carried on a general joinery business. David Hoadley and Lemuel Porter were in his employ at this time, and afterwards Samuel Hoadley was also an employee. The first clock charged on his books is to Major Morris, January 1st, 1791, £312s. This would indicate that the clock was made during the year 1790. The second is to Mark Leavenworth, February 2d of the same year at £4 and the next to Captain Lemuel Judd on the 19th of the same month at £4 with a credit to the Captain on the same date of one gin sling at 7d. and a load of wood at 2s. 6d. Mr. Harrison remained here until the spring of 1802 when he moved to a small shop on what is now Main St., where he had a water-wheel for power and brought the water to run it in logs from the creek across the road."

He afterwards removed to the site of the Lower Grist Mill and sold the business to Colonel William Leavenworth, and removed to New York State where he died a short time after. Colonel Leavenworth did quite an extensive business for some years, but after the war of 1812 became financially embarrassed and was obliged to give up business. He afterwards removed from the State."

MARK LEAVENWORTH.

This man was another of the early clock-makers of Waterbury; he was born in New Haven, Aug. 31, 1774. He worked at various mechanical occupations until 1806, when he commenced making clocks in Waterbury, in company with William K. Lampson and Anson Sperry. Their first location was at the beginning of Bucks Hill Road, where Mr.

DIAMONDS.

Wm. S. Hedges & Co.,

Importers of Diamonds,

And Manufacturers of DIAMOND JEWELRY.
 No. 170 BROADWAY, } New York.
 S. E. Cor. Maiden Lane, }
 27 Holborn Viaduct, London.



“ S ”

A "NOVELTY" in Marquis Rings.

ASK YOUR JOBBER FOR

STERN BROTHERS' DIAMOND MOUNTINGS,

42 MAIDEN LANE, N. Y.

MAXHEIMER & BERESFORD,

MANUFACTURERS OF

FINE DIAMOND JEWELRY,

No. 3 Maiden Lane, New York.

ORDER WORK A SPECIALTY.

TO THE TRADE ONLY.

Balance Staffs, - 60 Cents.
 Inserting Pivots, 40 Cents.
 ALL OTHER WORK IN PROPORTION.
 SEND FOR PRICE LIST.
 THOMAS JUZEK & CO.,
 ELGIN, ILL.

R. A. Kipling

Importer of Precious Stones

31, Union Square
New-York

19, Rue Drouot
Paris

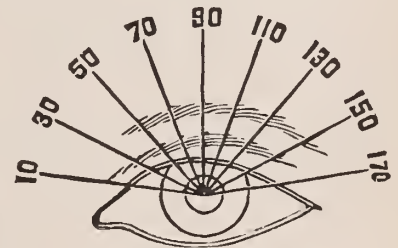

SEND TO

GENEVA OPTICAL CO.

23 Washington St., Chicago.

FOR PRESCRIPTIONS, REPAIR AND ORDER WORK PROMPTLY AT LOWEST PRICES.

SEXTON BROS. & WASHBURN,

41 MAIDEN LANE, NEW YORK,

MANUFACTURERS OF

FINE JEWELRY,

INCLUDING A FULL LINE OF MOUNTINGS.



PROMPT AND CAREFUL ATTENTION GIVEN TO SPECIAL ORDER WORK.

A. N. CLARK, PLAINVILLE, } MANUFACTURER of the Celebrated
 CONN. }

LOOP WATCH KEY.

The best for the price in the World. Size
 of Square stamped on each Key.

Also Key Rings, Watch Case Springs,
 Jewelry Tools, Tweezers, Etc.

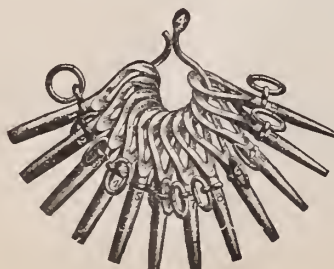

SEND FOR PRICE LIST. * SOLD BY ALL JOBBERS IN THE LINE AT MANUFACTURER'S PRICES.

Leavenworth afterwards had a boarding house.

Mr. Leavenworth's partners withdrew from the business after a short time and he carried it on alone. When shelf clocks came into general use he also commenced to make them, and in 1819 he sent a wagon load of five hundred clocks to Tennessee, the men camping out by the way. Mr. Leavenworth became interested in button manufacture in 1829, and in 1835 abandoned clock-making entirely. His early educational advantages were very limited, but by reading and observation he became a man of much intelligence. He died in Waterbury, Sept. 5, 1849, at the age of seventy-five.

ASA HOPKINS.

Asa Hopkins was a clock manufacturer in the parish of Northfield, in the town of Litchfield, Conn. He started there in 1810. He perhaps distinguished himself more than any wood clockmaker of his day, by the insertion of a mandrel with three spindles, one above the other, for sawing out the teeth of wheels and rounding them, all at one operation. The saw on the first mandrel made a straight cut towards the centre of the blank. The next saw was set at an angle, and cut the back of the tooth, while the third rounded the end of the tooth, so that each tooth was finished before commencing on the next one.

He was considered one of the best mechanics in the line at that time, and his clocks ranked in quality with any in the market. He made wooden clocks of the prevailing style until his removal to Plymouth Hollow in 1830, where he built a shop and engaged in the manufacture of musical instruments.

ORLANDO PORTER, ZENAS COOK AND CLARK,
COOK & PORTER.

There seems to be an uncertainty as to the exact time when Orlando Porter commenced clock-making in Waterbury, but we do know that he sold his business to Zenas Cook in 1811, and the indications are that he had carried on the business alone there some three or four years.

The movements of his clocks were of a large size. His shop was located near what is now Canal St., in the city of Waterbury. Mr. Cook carried on the business until the shop was destroyed by fire in 1812. Soon after this a new firm was formed, composed of Daniel Clark, Lemuel Harrison, Zenas Cook and William Porter, who built a shop on South Main St., using Great Brook for their power. They also bought the shop of Col. William Leavenworth, who had become involved and was obliged to give up business. The firm continued there until 1814, when they found themselves obliged to "cease from grinding," owing to financial

difficulties. They had at the time some unfinished movements on hand, but the greater portion of these were afterwards finished by Mr. Clark and sold. He took what remained, and moving to a farm, stored them in his barn loft. Many years afterwards they were found by some mischievous boys, who "finished them up" very quickly. William Porter, Lemuel Harrison, and Zenas Cook continued to reside in Waterbury and vicinity until their death. Orlando Porter removed to Harrisburg, Pa., where he died in 1838, and Daniel Clark removed to Talmadge, O., where he spent the remainder of his life.

(To be continued.)

New York importers of platinum do not place much belief in the statement that has recently been extensively circulated to the effect that a platinum mine has been discovered in Australia which yields 160 pounds of the metal to the ton of ore. When it is stated that three ounces of gold to the ton of earth is considered a good result, the Australian discovery ranks as a Monte Cristo story of high quality and stamps itself as preposterous and a bubble. At least such is the general opinion.

SEE OUR INDUCEMENTS TO NEW SUBSCRIBERS ON PAGE 45.

JAMES P. SNOW.

ESTABLISHED 1834.

CHAS. E. WESTCOTT.

SNOW & WESTCOTT,

SUCCESSORS TO G. & S. OWEN & CO.
MAKERS OF

FINE JEWELRY,

Lace Pins, Ear Rings, Scarf Pins, Sleeve Buttons, Sash Pins, Collar Buttons, Bracelets, Studs.

All Goods sold by us are exclusively of our own manufacture and are warranted 14 K. Fine, and stamped as such when possible.

No. 3 MAIDEN LANE, NEW YORK.

**STOP!
START!**

THE WALTHAM SCHOOL OF HOROLOGY,

D. D. PALMER, Teacher and Proprietor.

Best Advantages in the Country for Horological Instruction.

All branches under the personal supervision of D. D. PALMER, for a number of years in charge of the Adjusting Department of the Waltham Watch Co. POSITIONS GUARANTEED TO APT PUPILS. For terms and other particulars, address

D. D. PALMER,
WALTHAM, MASS.
Specialty of Difficult Repair Jobs.

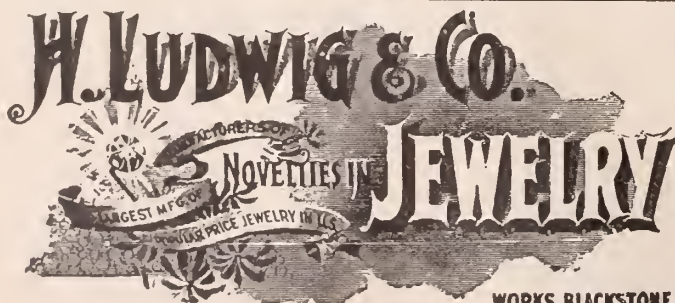

NEW YORK OFFICE,
PRESCOTT BUILDING,
ROOM 40. SAMPLES ONLY.

WORKS, BLACKSTONE & GAY STS.
TAKE PRAIRIE AVE CAR

Providence, R.I.

ROBERTSON & LEBER,

GOLD, SILVER AND

PLATINUM

REFINING.

PLATINUM SCRAPS MELTED

13 & 15 Franklin Street, Newark, N. J.

JEWELERS' SWEEPINGS A SPECIALTY.

PLATINUM FOR SALE.

**A Wonderful
TOOL
FOR THE BENCH.**

Instantaneous in Its Work.



Dividing the inch into one thousand parts. A most practical tool for watchmakers for gauging from a hair-spring to a main-spring. Non-comparable for a height and depth gauge. Instantaneous for hair-spring work.

For sale by all Jobbers.

NORDMAN BROTHERS,
120 Sutter St., SAN FRANCISCO, CAL.
Sole Agents for the United States.



Position of Balance Spring.—If, when the spring is pinned to the collet, it stands away from it at the points where the pin is inserted, it will be useless to attempt to bring it closer to the collet by bending it on the collet; therefore, it must be unpinned, and the eye bent in a little, so as to get the center true. When the spring runs true, the collet can be put on an arbor, and there is then very little trouble in getting it flat. I am now speaking of hardened and tempered springs, or those springs that are hardened by chemical process, and are more difficult to handle. Soft springs can be bent to any shape or form. Some years ago, someone published an essay on the balance spring in England, and gave a few diagrams of springs, showing how they grew shorter as they grew older, and the way these springs were made to answer was by a process known as white throating, that is by scraping with a graver about an inch of the outer end of the spring to reduce its strength. This is complete botching, and the workman who resorts to it can have no respect for himself and need not look for respect from others.

To Clean a Watch.—"For cleaning", says a correspondent, "I use benzine and alcohol. I have two wide-mouthed bottles, one for benzine and one for alcohol. I also use two camel's hair brushes, one for each bottle. Take up one piece at a time in a stiff pair of tweezers, dip your brush in the benzine and brush off well with the benzine, and then take the other brush and brush off with alcohol. The benzine takes off the dirt and oil and the alcohol takes off the benzine. Always take out the mainspring. Clean the mainspring by holding in your tweezers and brush off with benzine, putting plenty on and let it run off at the end of the spring; brush over with alcohol. Clean the barrel the same way. Lay the pieces on one side as you clean them."

To Choose a Balance-spring.—A very common and at the same time very uncertain method of finding the strength of a spring is by lifting the balance itself. The almost uselessness of this method is seen when we know that the diameter of the balance has so much to do with the timing of the watch or its weight, and the diameter in this case counts for nothing. A spring should be chosen that is smaller than the circle of the stud hole and index pins. That is, the spring should look small when the balance is at rest, as a spring of this size has more freedom of the coils or at those parts of the coils that lie between the stud and the balance staff, and therefore assists in quickening the short arcs of the balance.

WE MAKE FOR YOU TO SELL

The following lines, all of the best stock and made by the finest skilled workmen. F. & B. stamped on our cards, tags, etc., means that we know what we are about when we guarantee our goods:

Ladies' and Gentlemen's Chains that arc right; will wear ten years.

Locketts and Charms in endless variety.

Bar Pins and Cuff Pins, fine in quality and cheap in price.

Sleeve Buttons, "The Mount Hope," the best in the world.

Chain Mountings for Hair and Silk Chains.

Bracelets, Curb with padlock or snap, Polished plain, Roman plain chased bright, chased Roman, also silver oxidized.

Stanley, Jefferson and Washington Bracelets in solid silver. Glove Buttoners, the interlocking.

Scarf Pins, Jersey Pins, Bangles, Earrings, Bead Necks, Neck Chains and Garters.

FOSTER & BAILEY, Prov., R. I.

SOMETHING • NEW.

ALUMINUM THIMBLES.

Light, Durable and will not tarnish.

In appearance similar to Silver, and at half the cost.

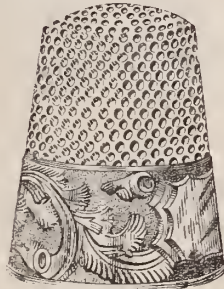

If you want something NEW, HANDSOME and CHEAP, send, enclosing business card, for samples and prices.

KETCHAM & McDOUGALL,

198 Broadway, New York.

JOHN B. YATES,

No. 147 NASSAU STREET, NEW YORK.

WATCHES

SPECIALTIES: UNITED STATES WATCHES

I have a limited number of Discontinued American Waltham Gilt Hunting, price formerly \$12.65, same grade as the "Taylor" (Elgin) Movement, for \$10.50 Net.

BURDON'S SEAMLESS.

THE ORIGINAL
And only Genuine



AND
Perfect Seamless Filled Wires
IN THE WORLD.
Sold to all Manufacturers
alike.
Burdon Seamless Wire.
TRADE-MARK.

The success of the BURDON SEAMLESS FILLED WIRE, like that of all important inventions, has been followed by deceptive and imperfect imitations. For the protection of ALL JOBBERS AND RETAILERS,

we authorize manufacturers who so desire, to affix upon the tag, card or label accompanying the articles made from this wire, this registered trade-mark owned by this Company.

The bird-on-wire is a guarantee that the goods are made from the original Burdon Seamless Filled Wire, the reputation of which has been firmly established among the best dealers for more than two years. The perfection and qualities of the Burdon Seamless Wires are always guaranteed. All Dealers (jobbers and retailers alike) should, therefore, demand goods made from the original Burdon Wire, and avoid imitations which are offered as "just as good."

BURDON SEAMLESS FILLED WIRE CO.,
109 to 119 and 127 Summer Street,
PROVIDENCE, R. I.

TELL A. BEGUELIN,

IMPORTER OF
WATCHES,

Watch Materials, Tools and Glasses,
No. 71 NASSAU STREET,
(UP STAIRS.) NEW YORK.

Sole Importer of Material for the
"Bijou," "Victor," "Boston," "Bristol,"
"Adelphia," "Jockey Club," "Wallingford,"
"Cesar," "Lady Racine" and "New Haven"
Watches.

AMERICAN WATCHES,
ALSO STEM WIND WHEELS.
IMPORTER OF
Full Line of **SWISS WATCHES,**
ALSO IMPORTER OF
FRENCH CLOCK GLASSES.

S. COTTLE & CO.,
MAKERS OF
FINE JEWELRY AND SILVER
NOVELTIES,
No. 86o Broadway, NEW YORK.

ARTIFICIAL EYES!



STOCK ORDERS of
Selection Packages,
Largest Assortment.

GENEVA OPTICAL CO.,
23 Washington St., Chicago.

R. & L. FRIEDLANDER,

Wholesale Jewelers,

—AND—

JOBBER'S IN AMERICAN WATCHES,

Tools, Materials and Optical Goods,

65 & 67 NASSAU STREET, N. Y.

Factory, 50 BOND STREET.

Send Business Card and we will mail you our Watch and Jewelry Catalogue, No. 12,
and our Tool, Material and Optical Catalogue, No. 14.

Try our **Monarch American Mainsprings,** \$12.00 PER GROSS,
\$1.00 PER DOZEN.

POSITIVELY NO GOODS SOLD AT RETAIL.

Established 1872.
PLAINVILLE STOCK CO.

P. S. CO.

THIS TRADE-MARK REGISTERED, AND STAMPED ON ALL OUR GOODS.

BROOCHES, SCARF PINS, DROPS, SETS.
FACTORY AT PLAINVILLE, MASS. SAMPLES AT 176 BROADWAY, NEW YORK

DIAMOND SETTINGS. GALLERIES. HOLLOW BALLS, ETC.

BLANCARD & CO.,

36 & 38 JOHN STREET,

SEND FOR OUR NEW YORK. CATALOGUE.

MUSICAL JACOT & SON,
298 Broadway,
New York
Send for Catalogue.
BOXES.
Musical Boxes Repaired.

GILBERT T. WOGLOM,
BLACK MAKER OF
PEARL ORNAMENTED
AND PLAIN
JEWELRY. **ONYX**
GOLD MOUNTED.
32 & 34 John St. New York City.

BIRTHDAY RINGS,

In Handsome Novel Window Tray,

(Patented.)

M. B. BRYANT & CO.,

10 Maiden Lane, New York.

The Other Side of Life.

FASHION NOTE.

Missionary teeth on strings are the latest design in necklaces.—*Umji Jimji Gazette.*

Goats are said to be extremely indifferent to what and how they eat; but we have seen one eat his breakfast off a time-table.

BOTH COULD NOT SEE IT.

On the Rialto.—H. IRVING BOOTH (indicating enormous stone on his bosom).—Prithee, thou would'st not think that this stone cost \$500, would'st thou?

POSSART BARRETT.—No.

H. IRVING BOOTH.—Neither would'st I.

IN PHARAOH'S HALLS, B. C. 500.

PHARAOH—Well, what do you think?
TOURIST—Aw, all your decorations, seem to be, doncherknow, in the blasted Egyptian style.

LET HIM DOWN.

MRS. MAGNUS SCOTT.—Now, Magie, don't forget that bonnet you promised me for Easter.

MR. MAGNUS SCOTT.—Oh, no. But, by Jove, business has been extremely dull.

Let us compromise. Instead of buying you the bonnet I promised you, I'll buy you that Imperial diamond I told you about. Its price is only \$3,000,000, and it will let me down.

SIMPLE ADDITION.

(On the train.)—NERVOUS PASSENGER—Can you tell me the time?



UNAPPRECIATED.

MRS. QUILTY (who has presented Quilty with a pair of ear-muffs).—"Hov yez thim on yez, John?"

MR. QUILTY.—"Oi hov, Kathie; but th' felly that sould yez thim specs chated yez. Sorra th' t'ing Oi kin see!"—*Judge.*

IRRITABLE MAN (sullenly taking out his watch).—Two o'clock.

(Some time after.)

NERVOUS PASSENGER—Can I bother you again for the time, please?

IRRITABLE MAN.—Two o'clock; didn't I tell you so an hour ago?

NERVOUS PASSENGER.—Then it must be three o'clock. Thanks.

CONCLUSIVE EVIDENCE.

CUSTOMER—You say this is a real antique?

BRIC-A-BRAC DEALER—It's one of the finest pieces of work by one of the best ancient masters of the present day.

NINETEENTH CENTURY PROGRESS.

ARTIST.—That's my latest, "old Father Time."

FRIEND.—He doesn't seem to be in his usual position. I never knew he rode on a machine.

ARTIST.—Well, you see, to be up to date, instead of old Time using an old-time scythe, I made him ride a patent curved cutter-bar, suspension spring, compound lever mower.

SOARED AFTER THE UNSOARABLE.

"Lorenzo," piped Angelina, as her gold-decked head nestled against his three days' unwashed shirt, "do you ever yearn after the unattainable and reach after the unreachable?"

"Verily," answered Lorenzo, "I doth, ever and anon."

"Ah, and for what reacheth thou, and yearneth thou?"

"For a raise in my salary, love."

SOMETHING MORE DIFFICULT.

"What wonderful progress the science of optics has made in the past ten years! The difficult complaints, astigmatism, myopia, hyperopia, ermetropia and others have been found—"

"There is one thing I can't understand."

"What's that?"

"How they found out their names."

TO THE TRADE.

FINE WATCH REPAIRING

BY

JOHN C. SIMMONDS,

18 JOHN STREET,

NEW YORK.

New pieces, such as Chronometer Locking Springs, Balance Staffs, &c., made in the best styles. Watches sprung and adjusted to temperature and motion.

G. F. FEINIER,

MANUFACTURER OF

WATCH CASES,

Repairing of Every Description,

NO. 9 BOND STREET, NEW YORK.

Key-Wind Cases Altered to Stem-Wind, and made same as New. English Cases Altered to take American Movements.

ESTABLISHED 1837.

TAYLOR & BROTHER.

OLD HOUSE READ, TAYLOR & CO.,

IMPORTERS OF

DIAMONDS and PRECIOUS STONES,

CLOCKS AND BRONZES,

860 Broadway, cor. 17th Street, N. Y.

Branch Office for Clocks and Bronzes,

1½ MAIDEN LANE N. Y.,

Chicago College of Horology,

SUCCESSORS TO

THE CHICAGO HOROLOGICAL INSTITUTE,

IS ACKNOWLEDGED by those who have investigated the subject to be a

FIRST-CLASS INSTITUTION,

Where those who desire to learn the art of WATCH MAKING and ENGRAVING can obtain the

BEST PRACTICAL INSTRUCTION.

New features are continually being added. It is the aim of those conducting the management of the College to make it the

BEST INSTITUTION of the kind IN THE COUNTRY.

C. R. HART, General Superintendent,

CHICAGO COLLEGE OF HOROLOGY,

CHICAGO, ILL.

WRITE FOR PROSPECTUS.

PROTECT YOUR STOCK!

Burglar-Proof Protection Practically Tested.

The following letter received by Mr. W. H. BUTLER, Agt.,

Diebold Safe & Lock Co., 79 Duane St., New York,

from a practical man of an inquiring mind, may help others to decide where to place their orders for burglar-proof safes:

WALTER WARE,
JEWELER,
219 BROAD ST., WAVERLY, N. Y.

Mr. W. H. BUTLER.

February, 23d, 1891.

DEAR SIR:—The fire and burglar-proof safe you made for me is here. Before taking it from the station, I removed the covering, unlocked the doors and made a careful examination of it; both in regard to its appearance and general mechanical make up. As to looks it is a beauty, or as all who see it say, it is the finest safe they ever saw. I am well pleased with the fine workmanship displayed in the fitting of the doors and bolt work, and everything works first-class. Having bought this safe because I needed a burglar-proof one and being of an investigating turn of mind, I desired to test its drill-resisting qualities for myself. After obtaining permission from you to do so, I went to the station with three hard drills and a file. I tried a drill on the front plate and it soon struck the hard metal, and I could get no further than the thin soft layer on the outside. I then tried a drill on the inside of the door and drilled through the half inch of soft steel backing, and very soon my drill began to turn easy and finally spun around as easy as if it was not touching anything. I took it out and found the point entirely gone and the end polished. Not being willing to give it up I sharpened the drill again, bore on harder and tried my best to make it take hold but it was of no use. It would not cut a bit. I still kept on trying but finally gave it up.

I am satisfied now, that the safe is all you represented it to be, that it is drill proof for several hours, and when I leave my things in it at night, I have no fear that I will not find them there in the morning.

The crane hinge works splendidly, closing the door tightly against the packing, making an air-tight joint. Altogether it is a fine job and I am more than satisfied with it.

Your good faith in the matter was evidenced by the willingness you showed to have me test it, although you had agreed to do nothing of the kind.

I shall take pleasure in showing it to any prospective customers you may find in this immediate vicinity.

Very respectfully yours, WALTER WARE.

This safe was built of the Celebrated Chrome Steel, which is used by the DIEBOLD SAFE & LOCK COMPANY of Canton, Ohio, in constructing their burglar-proof safes and vaults. JEWELERS contemplating the purchase of a burglar and fire-proof safe will find it greatly to their INTEREST to write for PRICES, REFERENCES, SPECIFICATIONS, etc., to

W. H. BUTLER, AGENT,
DIEBOLD SAFE & LOCK COMPANY
79 DUANE STREET NEW YORK.

Maiden Lane in 1849.

FORTY-TWO years ago the dry goods trade shared Maiden Lane with the jewelers. In fact, at that time, fifty per cent. of the business houses dealt in dress goods, in one branch or another, and the thoroughfare did not then enjoy its present term of the "Street of Gems." During the following years, however, the development of the country created a demand for American-made goods, and factories began to spring up in all directions, from Maiden Lane to as far "uptown" as Reade St., which at the time of which we write, contained many prominent workshops. Gradually the dry goods trade began to realize the necessity of its moving to a neighborhood where it could expand itself, and, as firm after firm moved away, jewelry houses one by one planted themselves in their places, until they overflowed into Nassau and John Sts., and the surrounding thoroughfares.

The cut presented shows the buildings No. 10 to 26 Maiden Lane, and as can be seen by the business signs, jewelry firms and dry goods concerns stood together in fraternal juxtaposition.

At No. 10 the cloth importing house of Tracy, Irvin & Co. was located. The firm occupied the whole building and the top floor was devoted to the show room, where the country tailors could decide what design would best suit their trade.

Next door R. & H. Kipling hung out their latch string. They dealt in fancy goods and the first named partner, Richard Kipling, was the founder of the present diamond firm of E. E. Kipling. There were also in this building the dry goods houses of Chichester & Heath, and Stout & Goulding.

A. Journey, Jr., & Co., exhibited the latest London and Parisian styles at No. 14.

L. E. Rice, importer of watches, occupied an office at No. 16. His sign does not appear in the cut. He subsequently moved to 23 Maiden Lane, where he took into partnership W. B. Lawton, and the firm name became Rice & Lawton. C. & M. Smith had a workshop on the second floor of No. 16, where they produced gold pens and pencils, a trade not so extensive in those times as at the present day, quills being then the prevailing instrument for writing. The senior partner of this firm subsequently abandoned this business and connected himself with the importing house of Mitchell, Vance & Co., of Broadway and Twelfth St.

At No. 18 Charles Lupton conducted a watch case and repairing factory. In 1849 the rapid stamping machine was an appliance unthought of, and the ornamentation of a watch case required hours of labor with hammer and die. Mr. Lupton had formerly been in business in England, and he enjoyed an extensive trade. The entrance to his factory was on Liberty Place, which, a few years previous, had been known as Little Green Lane. The change was probably made because its rural suggestiveness conflicted with its business-like surroundings.

On the opposite corner of Liberty Place, at which, by the way, the present carpenter

PREMIUM LIST.

TO THE RETAIL TRADE:

We want 10,000 new subscribers added to our subscription list, and in order to get them we make some remarkable inducements for a LIMITED TIME ONLY.

SEND US TWO DOLLARS,

the regular subscription price of THE CIRCULAR, and we will send you any of the combinations described below, and

THE JEWELERS' CIRCULAR FOR ONE YEAR.

The articles in any of these combinations if purchased separately would cost from \$2.00 to \$3.00. They have been carefully arranged by an expert watchmaker as being such as are called for in every days' experience. They are first-class goods, will be carefully selected, and sent promptly. In ordering, be particular to do so by the letter as arranged.

COMBINATION A.

Two dozen American Cock and Foot Jewels, assorted as follows:

1/4 doz.	Waltham,	18s.	O. M.,	Cock.
1/4 "	"	18s.	"	Foot.
1/4 "	"	18s.	N. M.,	Cock.
1/4 "	"	18s.	"	Foot.
1/4 "	Elgin,	18s.		Cock.
1/4 "	"	18s.		Foot.
1/4 "	Illinois,	18s.		C. & F.
1/4 "	Hampden,	18s.		C. & F.

COMBINATION B.

Two dozen American Cock and Foot Jewels.

1/3 doz.	assorted Waltham,	18s.	C. & F.
1/3 "	"	18s.	Elgin,
1/6 "	"	18s.	Illinois,
1/6 "	"	18s.	Hampden,
1/6 "	"	18s.	Rockford,
1/6 "	"	18s.	Columbus,
1/6 "	"	18s.	Peoria,
1/6 "	"	18s.	Seth Thomas,
1/6 "	"	18s.	Trenton,
1/6 "	"	18s.	Lancaster,

COMBINATION C.

Two dozen American Endstones, assorted.
Same as Combination A.

COMBINATION D.

Two dozen American Endstones, assorted.
Same as Combination B.

COMBINATION E.

Two dozen American Balance Staffs assorted as follows:

1/3 doz.	Waltham,	18s.	assorted styles.
1/3 "	Elgin,	18s.	grades.
1/3 "	Illinois,	18s.	"
1/3 "	Rockford,	18s.	"
1/3 "	Hampden,	18s.	"
1/6 "	Columbus,	18s.	"
1/6 "	Seth Thomas,	18s.	"

COMBINATION F.

Eight dozen American Roller Jewels assorted as follows:

1 doz.	Waltham,	18s.
1 "	"	8s.
1 "	Elgin,	18s.
1 "	"	6 & 8s.
1 "	Rockford,	18s.
1 "	Illinois,	18s.
1 "	"	4s.
1 "	Hampden,	18s.

COMBINATION G.

Two dozen American Winding and Interwinding Wheels, assorted as follows:

1/3 doz.	Waltham,	18s.
1/6 "	"	8s.
1/3 "	Elgin,	18s.
1/6 "	"	6 & 8s.
1/3 "	Rockford,	18s.
1/3 "	Hampden,	18s.
1/3 "	Illinois,	18s.

COMBINATION H.

Two dozen assorted Yoke, Clutch and Click springs for Swiss Watches, the most desirable patterns and only those for which there is a constant demand.

COMBINATION K.

Six dozen assorted American Collected Hair Springs assorted as follows:

1 doz.	Waltham,	18s.
1 "	"	8s.
1 "	"	1s.
1 "	Elgin,	18s.
1 "	"	16s.
1 "	"	6 & 8s.

COMBINATION I.

Four dozen assorted Yoke, Clutch and Click springs for American Watches. Only such will be sent for which you will find steady demand.

COMBINATION M.

Two dozen *Harstroms* Pat. Casesprings, assorted sizes (considered to be the best and most easily fitted spring in the market.)

COMBINATION L.

One gross American Hands assorted as follows.

1 doz	18s. Spade, K. W.
1 "	18s. " S. W.
1 "	8s. " S. W.
1 "	8s. Morning Glory, S. W.
1 "	1s. Spade, S. W.
1 "	18s. Moon, K. W.
1 "	18s. " S. W.
1 "	18s. Morning Glory, K. W.
1 "	18s. " S. W.
1 "	18s. Seconds.
1 "	8s. "
1 "	1s. "

COMBINATION O.

Jewelry Findings assorted as follows:

1 doz.	Plated Clipped Catches.
1 "	" Joints.
1 "	Roll Plated Ear Wires.
3 "	Burnished Pintongs.
1/3 "	R. P. Lever Button Backs.
1/2 "	" " Spiral Stud "
1/3 "	" " Scarfpin "
1 "	" " Jump Rings assorted sizes.
1 "	Bracelet and Necklace Snap Catches.

COMBINATION P.

Two dozen fine American Mainsprings, assorted sizes, for Waltham and Elgin Watches.

Five dozen assorted Clark's (4 screw) steel lift and catch case springs suitable for Swiss and American cases.

firm of J. C. Hoe & Co. were located, were the offices of Platt & Bro., importers of watches and jewelry, and Draper & Eldridge, clothing dealers.

Next door, at No. 22, Benjamin Shreve was established. Mr. Shreve conducted a watch case factory, and he is one of the few

men of G. R. Cholwell, who manufactured pocket books and desks and was a prominent figure on the Lane. When the structure next door No. 26 was rebuilt he moved into it and remained there several years. There is a strange substantiation of history repeating itself in the fact that on the same site a

tenants of No. 26, the last building on the block. The latter firm suffered many financial reverses and finally failed. James F. Pitkin, is conducting a small repairing establishment at 4 State St., Hartford, Conn.

THE CIRCULAR has now completed the history of the buildings on both sides of Maiden



jewelers in business at that day who are still actively engaged. He is the senior member of the firm of Shreve, Crump & Low, 432 Washington St., Boston, Mass.

The little building at No. 24, which years previous had been a private residence, resounded with the many noises of the work-

pocket-book store is now seen. Connected in the business with G. R. Cholwell was his brother Jacob, who when the New York Police Department was organized was appointed one of the first commissioners.

F. W. Krantzke, a furrier, and Pitkin Bros., importers of watches, were the only

Lane, from Broadway to Nassau St., which for so many years have been the home of the American jewelry trade. We will next present the structures on the lower part of the thoroughfare, east of Nassau St., which, during the past few years, have become so prominent in the trade.

ESTABLISHED 1856.
WILLIAM PARK,
Stone Seal Engraver,
Arms, Crests in the highest style of Art. Also Gold Rings, Silver Seals, Brass and Steel Seals engraved SUPERIOR to Stone Seal engraving. Dies cut for Envelope Stamping in best Style.
26 JOHN STREET, N. Y.

H. H. HEINRICH,
12, 14 & 16 John St., New York.
Manufacturer of
MARINE CHRONOMETERS.
Silver Medal, Paris Exhibition, 1889.
A large stock of new and second-hand Marine Chronometers on hand. All my second-hand Chronometers are thoroughly overhauled, refinished and re-adjusted. Rented out at \$5.00 per month, payable in advance. No rent charged if bought within a certain time. Terms to suit customers. Marine Chronometers repaired and adjusted for the trade.



EXAMPLES OF CLASS PINS (COPYRIGHTED 1891), DESIGNED AND MADE BY HENRY C. HASKELL, 11 JOHN STREET. PLATES SENT TO DEALERS UPON REQUEST.



ROGERS & BRO. A-1.

OLDEST BRAND AND HIGHEST GRADE OF ELECTRO SILVER PLATE.

ROGERS & BROTHER, Manufacturers,

16 Cortlandt Street, New York.

Waterbury, Conn.



HOLLOW WARE.

Photograph Albums and Price Lists upon Application accompanied by Business Card.

HAVE YOU TAKEN YOUR INVENTORY?

HAVE YOU REMEMBERED? —Old gold or silver? If so, —That we pay 4 cents per kt. for gold and highest market price for old silver.

HAVE YOU TAKEN YOUR INVENTORY? —On hand a collection of old plated jewelry filings, sweeps, etc., or a lot of old jobs, which have been on hand for years, with no likelihood of being called for.

HAVE YOU TAKEN YOUR INVENTORY? —A lot of old style and unsalable jewelry on hand? If so, it would be good policy to dispose of same, convert the proceeds into an article that you would probably turn over several times, besides give your stock a nice, clean appearance.

OUR PLAN —Immediately on receipt of shipment, we will remit by cash or draft (as desired). If our offer should not prove satisfactory, we will return consignment in exactly same condition as received and pay all charges. By this arrangement you are absolutely safe, as it is no sale unless our offer should prove satisfactory, and you run no more chances than if you were disposing of same right over your counter. —Send for our little book giving pointers on testing and buying gold and silver. Mailed free on application.

GOLDSMITH BROS.

Gold and Silver Refiners and Assayers,
63 & 65 WASHINGTON ST., CHICAGO, ILL.

Columbus, Ga., Jan. 10, 1891.
Dear Sirs: Yours of the 7th inst. to hand, containing check for \$29.88. All satisfactory. Accept thanks.
Yours truly,
C. M. KINSEL.

Denison, Tex., Jan. 6, 1891.
Gents: Your draft of Jan. 3, '91, came to hand this day. Amount very satisfactory, (\$112.93).
Very Respectfully,
B. W. MERRILL.

Los Angeles, Cal., Jan. 6, 1891.
Messrs. Goldsmith Bros., Chicago, Ill.
Gentlemen: Your favor duly to hand, containing check for \$176.64, which is satisfactory to us.
Yours,
J. F. GRANAS & CO.

Little Falls, N. Y., Jan. 12, 1891.
Dear Sirs: Your favor of Jan. 9 received, which is satisfactory. Respectfully,
ANDERSON & HOUGHTON.

Keokuk, Iowa, Jan. 3, 1891.
Gentlemen: Accept thanks for check for \$153.58 in settlement for old silver.
Yours Resp'y,
T. R. J. AYRES & SONS.

Decatur, Ill., Jan. 19, 1891.
The check for \$65.45 is all satisfactory.
O. E. CURTIS & BRO.

4 Center Ave., Pittsburgh, Pa.
Gentlemen: \$54.32 received for old gold. Thanks. Am satisfied beyond expectation.
Respectfully,
H. SCHEINEMAN

Milwaukee, Wis., Jan. 23, 1891.
Gents: Your favor of yesterday, inclosing check for \$205.80, to hand, which is very satisfactory.
Yours truly,
C. PREUSSER JEWELRY CO.

St. Cloud, Minn., Jan. 2, 1891.
Gents: Your check of \$12.01 is very satisfactory, more than we expected to get. Many thanks.
Respectfully,
GEO. R. CLARK & CO.

Moberly, Mo., January 2, 1891.
Gents: Your express order for old gold received. Same satisfactory. I get a great deal of old gold and silver, and have sold same in New York and Philadelphia, but have never received what I thought full value until I commenced sending to you. This is my ninth shipment to you.
Respectfully,
A. F. SEELEN.

“WE CONSIDER” OUR **WEBSTER-WHITCOMB Lathe**, in fact, we **KNOW** it is

THE

BEST LATHE MADE.

SO DO THE FOLLOWING PARTIES WHO HAVE THEM:

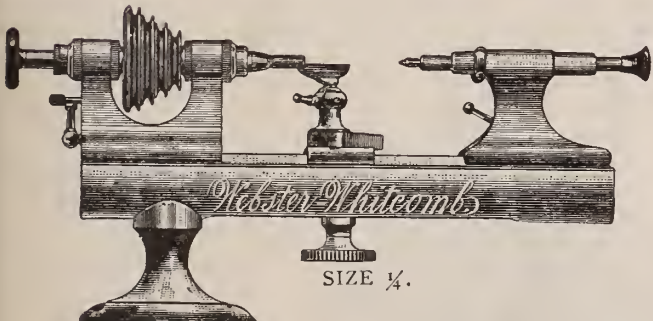

W. H. MAIRE, of Princeton, Ky., writes:
“The lathe is just at hand, and I assure you it is just what I want. It is as near perfection as they get, I think.”

S. T. RUSSELL, of West Plains, Mo., writes:
“The lathe is a dandy in every respect. It gives perfect satisfaction in every respect.”

OSCAR J. FUCHS, of Chillicothe, O., writes:
“My Webster-Whitcomb lathe is giving me No. 1 satisfaction, and I expect I will have to buy some more attachments soon.”

GEO. E. TEW, of Seattle, Wash., writes:
“My lathe is perfectly satisfactory, and I consider it the best lathe made.”

C. A. BECK, of Franklin, Ind., writes:
“I think more of my lathe than I do of myself.”

TAINTOR & McALPINE, of Easthampton, Mass., writes:
“We have one of your fine Watchmakers' lathes with full set of chucks, universal head, slide rest, filing attachment, etc., and find them perfect tools.”

With every lathe we send the following guarantee:—
“This certifies that the lathe marked ‘American Watch Tool Co., No. —’ was made by us from the best materials, on the most approved plan, and is a reliable lathe. For any defect in material or workmanship we hold ourselves responsible. Notify us promptly of any faults.
Waltham, ————
By ————”

This guarantee is also signed by the inspector who has the final inspection of the work. For several years past we have tied upon every lathe a tag of caution and instruction. All purchasers are requested to demand these documents with the lathes they buy. Remember our address:

AMERICAN WATCH TOOL CO.,
WALTHAM, MASS.

STONY BATTER WORKS



B. & W. B. SMITH,

220 West 29th Street, New York City.

The following Stores, Offices, etc., IN NEW YORK CITY are fitted entire or in part by B. & W. B. SMITH:

- | | |
|--|--|
| <p>Gorham Mfg. Co.,
Whiting Mfg. Co.,
Meriden Britannia Co.,
Reed & Barton,
Meriden Silver Plate Co.,
Simpson, Hall, Miller & Co.,
Derby Silver Co.,
Rogers & Bro.,</p> <p>Wilcox Silver Plate Co.,
J. B. & S. M. Knowles,
Pairpoint Mfg. Co.,
American Waltham Watch Co.,
Theo. B. Starr & Co.,
Camerden & Forster,
Black, Starr & Frost,</p> <p>Chas. W. Schumann,
London & Manchester Plate Glass Co.,
Fairbanks & Co.,
Rogers, Peet & Co.,
Redfern,
Park & Tilford,
Miller & Bros.,
E. M. Gattle,
Wm. Kirkpatrick,</p> <p>Howard & Co.,
F. M. Whiting & Co.,
Wallace & Sons,
J. H. Johnston,
Goldsmith & Co.,
Hamann & Koch,
Linherr,</p> <p>Dueber Watch Case Co.,
Jaques & Marcus,
Wm. Moir,
Dominick & Haff,
Mitchell, Vance & Co.,</p> | <p>Stern Bros.,
Macy & Co.,
Ridley & Sons,
Amasa Lyons,
Yandell & Co.,
Caswell & Massey,
Theo. A. Spear,
Dempsey & Carroll,</p> <p>Huyler & Co.,
Wallace & Co.,
Monopol Tobacco Works,
Samuel Budd,
Thomas Miller & Sons,
C. D. Jones & Co.,
Robt. Dunlap & Co.,
Youmans,
N. Espencheid,</p> <p>Chas. P. Murphy,
Gotthold & Co.,
Nathan Mfg. Co.,
Franke & Co.,
Simpson, Crawford & Simpson,
Gunther's Sons,
Lichtenstein & Son,</p> <p>Museum of Natural History,
Ladd & Coffin,
Metropolitan Museum of Art,
John Mason,
Tiffany & Co
Benj. S. Wise,
J. Alexander,
Aitkin, Son & Co.,</p> <p>Baldwin & Co.,
Brooks' Bros.,
Casperfield & Co.,
Middletown Plate Co.,
Meriden Cutlery Co.</p> |
|--|--|

COMPARE ALL OTHER GOLD FILLED CASES WITH THE CELEBRATED CROWN LION EXCELSIOR HAND ENGRAVED CASES H. MUEHR'S SONS

L. & W. KAHN & CO., IMPORTERS OF DIAMONDS, 10 MAIDEN LANE, N. Y.



S. P. HOWARD,
Gold and Silver Assayer,
Refiner and Sweep Smelter,
8 & 10 JOHN STREET, NEW YORK.
Smelting and Refining Works,
28, 30 & 32 Cumberland St., Brooklyn, N. Y.
Specialties: Sweepings, Gold, Silver and Platinum.

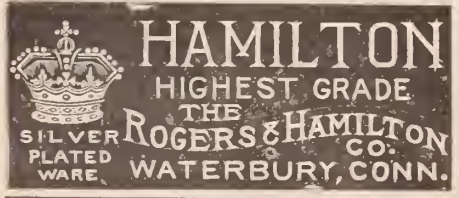

NEW! NATTY!! NOX-ALL!!!
Signal Eyelet Stud
PATENTED
OPEN. CLOSED.
NOX-ALL
STUD. OPEN. CLOSED.
Made in Gold, Silver, Gold Fronts and Rolled Plate. Easily adjusted. "Send for Approval Packages."
J. A. FLOMERFELT & CO.,
MANUFACTURING JEWELERS,
177 & 179 Broadway, - New York.
Branch Offices: 478 Monroe Street, Chicago.
1435 Palace Hotel, San Francisco.

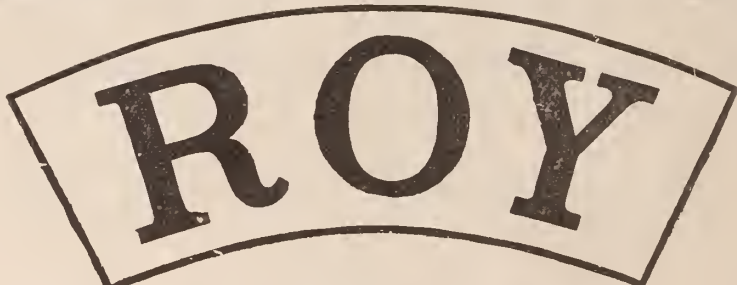

S. F. MYERS & CO., Wholesale Jewelers.

EVERYTHING
THAT
PERTAINS
TO THE
JEWELRY TRADE.
22
DEPARTMENTS.



WE REQUIRE
AND OCCUPY THE
LARGEST
SALESROOMS
IN OUR LINE.
4 STORES.
GROUND FLOOR.

48 & 50 Maiden Lane and 33 & 35 Liberty Street, New York.
CONSULT OUR MAMMOTH CATALOGUES.

SEE OUR INDUCEMENTS TO NEW SUBSCRIBERS ON PAGE 45.

CIRCULATION FOR
FEBRUARY,
40,150 COPIES.

SOUVENIR SPOON SERIES
NO 1.

LARGEST CIRCULATION
OF ALL THE
JEWELRY JOURNALS.

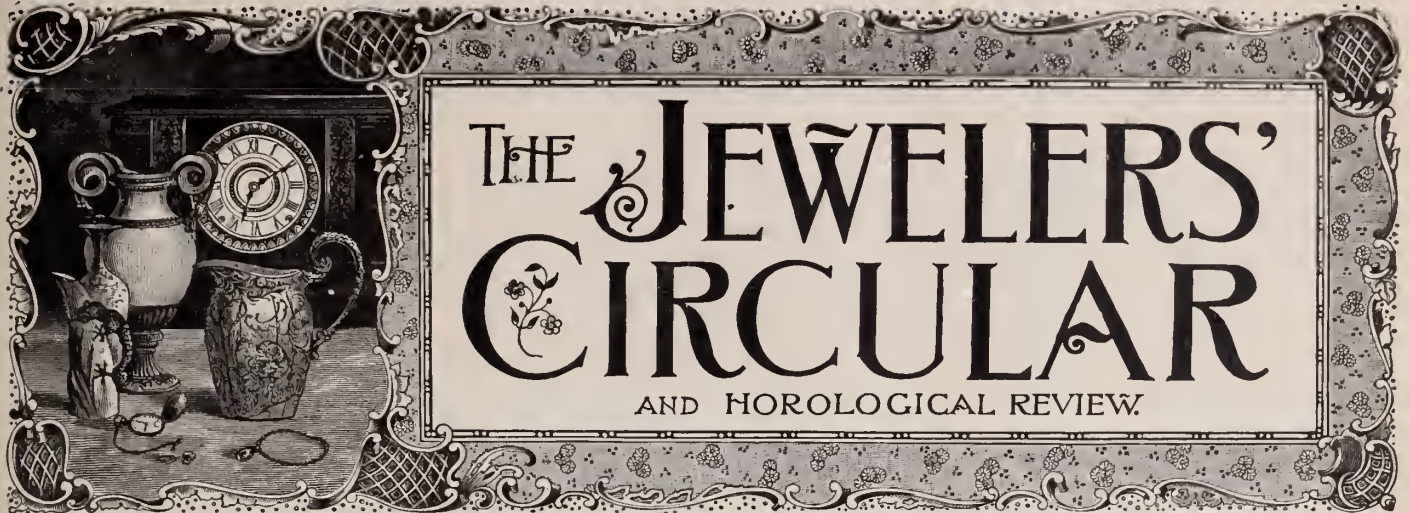

Entered at the Post Office in New York as second-class matter.

VOL. XXII.

NEW YORK, WEDNESDAY, MARCH 25, 1891.

No. 8.

SOUVENIR SPOONS.

PART I.

THE breath of another fad pervades the atmosphere. The active and unsatiated American public, ever seeking for variety, have something new to chatter about and interest or bore their intimates. The panorama of novelty has been turned, and the reign of souvenir spoons has begun. From Maine to California, from Minnesota to Florida, the cry is for souvenir spoons. People visiting a city, people who have visited a city, people who would like to visit a city, people who want to say they have visited a city, people who think it is the proper thing, the *recherché* thing, to have been a traveler, people who want others to believe that they have traveled, people who really believe that they have traveled, people generally of a self-conscious or sentimental disposition, in fact, almost everyone wants souvenir spoons, and the many manufacturers who have introduced them into the market, are reaping a rich harvest from their wakefulness and enterprise.

The fad offers one of the best opportunities for profit ever presented to the trade, and it is with that conviction in mind that this article has been written, so that every retail jeweler throughout the country may become familiar with all the designs made,

their owners and manufacturers, the *raison d'être* of the designs and extraneous points of

their customers with sound knowledge and intelligence.

When the thinking man appreciates that the collecting of individual spoons as souvenirs of visits to certain cities and places has become a broad fashion the first question he asks within himself is why should a spoon be chosen not only in preference, but to the exclusion of all other articles. There is no positive answer to this question; the commercial reason that a spoon admits of a combination of beauty of design and utility, and is not costly, may sustain the demand, but the demand must first be created. The very love of the spoon, which is innate in all hearts, may account for the selection. The desire for its possession is the unconscious production of a healthy mind. As all civilized people unconsciously live in accordance to a code of philosophy instituted several centuries ago, so may the demand for an article such as a spoon, in preference to another article be the unconscious desire evolved through centuries of innate love for it.



THE GORHAM NEW YORK SPOONS—NOS. 1, 5 AND 7.

interest which will prove advantageous to them, that they may converse with

tically of the same shape as to-day, was used by the Greeks, Egyptians, Assyrians

THE LOVE FOR A SPOON.

The oldest piece of silverware known is the spoon. Hundreds of years before the Christian era the spoon, practically

and others. Long before there was a knife or fork, the spoon fed the mouths of the people. The very word "spoon" conjures up visions of pleasure. Its very presence sets the salivary glands in action. The gluttonous nature innate in all, is aroused at its picture, and juicy ragouts, steaming soups and fricasses, stews and bouillabaisse pass before the vision. All love the spoon, the emblem of plenty, of fullness and content. From the day we begin to eat pap until the day, three score and ten afterward, when we begin to eat pap again, the spoon is a constant companion. In childhood, the knife may cut the mouth, the fork imbed its prongs into the flesh; but the spoon carries life and health with it.

The glass, the tankard, the loving cup, bring as much sorrow as pleasure into the world; the spoon all pleasure. The loving ladle enters into broils, the spoon does not. This statement may partake of jocular-ity, but it is truth. A THE ANNEKE JANS. ladle is an extremely handy article to belabor one's head with, while a spoon will hardly serve as a missile even. "He was brought up with a silver spoon in his mouth," is an English vernacular, meaning that the happy child had plenty of rich and luscious sustenance.

There is another reason that may be assigned for a spoon being the uppermost conception in the mind, especially a silver spoon. Such a spoon is a talisman; he who possesses one can never want. Else why did those grand old bandits of yore, Dick Turpin, Jack Shepard, Claude Duval and others, always make their way to the spoons upon entering a house? Novelists of past days would speak of a man who would steal his host's spoons as being out of the pale of human consideration.

The Dutchman's usual morning greeting is, "*Smaakelyk eten?*"—meaning, have you smacked your lips after eating; and is it possible to smack one's lips after using any instrument but a spoon? Similarly the Chinese *Ya tan?* Have you eaten your rice; or, in other words, have you used your chop-sticks or spoon?

Numerous other evidences can be produced that the spoon occupies a unique position in the materiality of the world. The earliest reminiscence of our lives, a reminiscence that has ever been pleasant, a constant companion especially attentive at our happiest moments—when we are eating—an article that adds to comfort and amplitude,



THE ANNEKE JANS.

an article admitting of an infinitude of patterns and ornamentation while preserving its use—these may have given rise to the fashion of collecting odd spoons which has existed for hundreds of years. It is said that this fashion, in many cases mania, is no way connected with that of collecting souvenir spoons, but one conclusion seems certain; that the spoon is preferred in both cases for the same reasons.

Perhaps the earliest custom approaching the present practice was the giving among princes of the silver or golden cups each drank from at a feast. Of the nine thousand individuals who feasted with Alexander at Susa, every one received a golden cup. In later times, guests did not wait to be presented, but actually helped themselves to the spoons and cups. The practice became so common that it was positively recognized by law as a right.

SOUVENIR SPOONS IN EUROPE.

Among the cities all European travelers visit is Nuremberg, in the Kingdom of Bavaria. The city is monasterially quiet, the deep religious feeling seeming to be breathed even from the very stones. This is principally owing to the only feature of the city the massive cathedral which has stood for centuries, a mark of faith and fervor of a homely people. Through its long corridors and aisles have wandered the annual army of sight-seers, who, when they have departed from the city, have deemed it incumbent upon them to take something with them as a souvenir of their visit. No article seemed to present itself but an apostle spoon with which the city seems to abound. These spoons had a miniature of some loved saint, as St. Peter, at the head of the handles. At Rome the same sentiment was excited with the same result. Finally in traveling from city to city, to Munich, Würtemberg, Milan, Florence, Geneva, St. Petersburg and other points, tourists manifested a desire to take from each place a spoon with some characteristic of the town as a memento of their visit; thus the Martin Luther spoon of Würtemberg, and others were originated.

The custom of giving apostle spoons at christenings is ages old. It was in imitation of the heathen who introduced figures of their gods upon almost every utensil. The apostle selected was he whose commemoration day came nearest the day of christening. In Holland as far back as the 17th century, the practice was to give trade spoons as wedding gifts—the figure of a baker, sailor, game-keeper or whatever the donor may have been, decorating the head of the handles.

THE FAD'S WAY TO AMERICA.

American tourists on the Continent would with their European co-travelers pick up odd spoons at various places, and returning home desired to carry out the same practice. As they traveled from city to city they looked for odd spoons; but hardly finding or perhaps even knowing what they wanted, they bethought them at first that the name of the city etched in the bowl would prove sufficient;

but later, it struck them that some characteristic feature of the city, as a public building, a point of interest and so on, would add sentiment and individuality to each article.

About two years ago M. W. Galt, Bro. & Co., Washington, produced a copyrighted design of a Washington spoon, depicting a head of the Father of the Country on the top of the shank. The firm are thus entitled to the pride of being the originators of the fad in this country from a commercial standpoint. During last summer, Daniel Low, Salem, Mass., took a trip to Europe, and made a collection of spoons as others had done before. Upon his return he conceived the idea of getting out a spoon for Salem, the home of witchcraft, and succeeded in producing the now celebrated Witch spoon. Over seven thousand of them have been sold, and their circulation has undoubtedly created the demand for spoons representing other cities. The time was ripe when Daniel Low began, but his enterprise gave impetus to the fashion. The fad spread throughout the Eastern States, silver-smiths at Boston, Lynn, New Bedford, Haverhill, Plymouth and at other places, devising spoons for their several places.

At this point, New York city woke up, and the manufacturers produced many designs, all of which contain more or less beauty.

In proceeding with this subject, spoons of New York city are discussed first, solely as a matter of convenience to the writer.

That city is, of course, more fruitful in designs than perhaps any other, fourteen having already been produced, with additional ones under way, which will raise the number to at least twenty. The demand in that city is of course, greater than elsewhere, and manufacturers more numerous. In many respects, though the designs are beautiful, characteristic and unique, they do not excel those of some other towns. After



THE KNICKERBOCKER.

the New York spoons are disposed of in this instalment of the article, those of other sections of the country will be fully described and illustrated.

TRADE
SEAMLESS
 MARK.
GOLD · FILLED · CHAINS.

ON ACCOUNT OF

THE great popularity of the chains made exclusively by us for the past three years, the air has been FILLED and the paper of the various Jewelers' Journals COVERED with the word "SEAMLESS" which has been and is our trade mark.

We never had such a boom in our business as we have had since our friends commenced to advertise our goods.

We have only a word to add, and that is we make and sell the

ORIGINAL AND GENUINE
SEAMLESS GOLD FILLED CHAINS.

In addition to the word SEAMLESS and for the protection of our customers we place upon each Chain a tag bearing the following trade-mark :



Which is affixed by authority of its owners, as a guarantee that the Chains are made from the Burdon Seamless Filled Wire.

<p>BOSTON OFFICE, 6 WINTER STREET, In charge of I. W. STELLE.</p>	<p>NEW YORK OFFICE, 17 Maiden Lane.</p>	<p>PACIFIC COAST AGENCY, WM. E. PETTES & CO., PHELAN BUILDING, SAN FRANCISCO, CAL.</p>
---	---	--

Address all communications to

KENT & STANLEY,
 PROVIDENCE, R. I.

The designs of souvenir spoons have four *motifs*; historical, legendary, municipal and general and honorary and personal. By historical is meant the representation of some event or personage of history; by legendary, some fictitious personage or tale that has been told by so many fathers to sons, that we almost believe that such did exist or is true; by municipal, some public building or structure of interest; by honorary, some miniature of a citizen who is or was the pride of the city. So far, the New York designs comprise only the first three. We will discuss those of an historical significance first:

THE ANNEKE JANS.

This little spoon, an illustration of which is presented, is one of the neatest affairs produced, and has proved very salable. The very euphony of the name is a point in its favor. The two words flow into each other with music and rhythm. *Vrouw Anneke Jans* was among the early settlers of Manhattan Island and owned the property now covered by Trinity Church, in addition to vast tracts where the Bowery and lower Broadway now run. She died leaving five

children, whose heirs are constantly bringing actions against the present claimants of the property. In the centre of the top of the spoon appears the lady's head with fat face surrounded with ruff and headgear. The likeness is said to be an excellent one, it having been reproduced from an old woodcut. Along the handle is stamped the name in straggling, irregular letters. The *Anneke Jans* is made of oxidized silver in coffee spoons, sherbet spoons, paper cutters, butter spreaders, sugar tongs and bonbon spoons.

THE KNICKERBOCKER.

In the head of this spoon, as depicted in the illustration, old Dietrich Knickerbocker sits, as his name says he should sit. The Knickerbockers were citizens of the town of Schaghticoke, where Irving says folk lay stones upon the houses in windy weather, lest they should be blown away. The family derive their name from *Knicker*, to shake, and *Beker*, a goblet, indicating that they were sturdy toss-pots of yore; this is one etymology, the popular one. So it is natural that old Knickerbocker should be represented as juggling a tankard. Another Knickerbocker design shows the old Dutchman

seated at a desk, poring over books, which represents the true meaning of the name *Knicker*, to nod, and *Bocken*, books; nodders or dozers over books. The name is stamped as in the *Anneke Jans*. The design in each case is accurately executed, the workmanship being excellent and the finish perfect. The first mentioned design seems to be the more popular. The demand is heavy and increasing. The Knickerbocker is made in the same articles as the *Anneke Jans*, excepting in coffee spoons; it is also applied to numerous other articles.

THE PETER STUYVESANT.

Peter, the Headstrong, with whom is associated in everyone's mind, a scarcity of legs in the world, leans on his cane at the head of this spoon. The miniature is taken from a correct picture of the old Dutch governor, and in workmanship is excellent. The details of the wooden leg, the cane, the costume, the face and posture are perfect. Peter Stuyvesant was the last Dutch governor of New Amsterdam, and was a man of infinite will and crotchet. He stands out a prominent figure in the early history of New York, and the application of his miniature is

... THE WHITTIER SPOON. ...

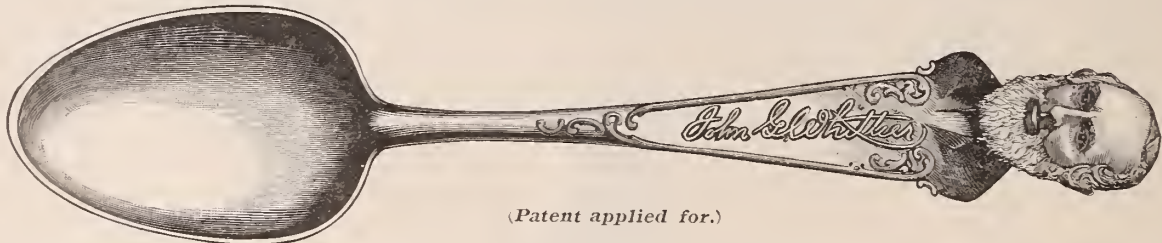

(Patent applied for.)

WE offer to the trade THE WHITTIER SOUVENIR SPOON, which we have originated and designed in honor of America's greatest living poet, John Greenleaf Whittier. They are made of sterling silver only, and in four patterns, representing, respectively, the head of Mr. Whittier in relief, his birthplace, his Amesbury home for upward of half a century, and "The Captain's Well." Each spoon will have the autograph of Mr. Whittier in fac simile. (We have his permission for the exclusive use of it on silverware.) We are confident that there will be a large and immediate call for these spoons; already we are receiving orders from retail dealers in different parts of the country. Will mail price lists and cuts on application.

H. G. HUDSON,
AMESBURY, MASS.



This cut represents our new "WHITTIER BIRTHPLACE" Souvenir Orange Spoon.

PATENTED, MARCH 3, 1891.

An exact likeness of the place where the poet was born, in Haverhill, Mass.

Made only in Sterling Silver and of good weight.

In all kinds of Spoons and Forks.

DESCRIPTIVE CIRCULAR AND PRICE LIST SENT ON APPLICATION.

H. L. DOLE, JEWELER AND SILVERSMITH,

19 MERRIMAC STREET,

HAVERHILL, MASS.

... This design is patented and is the only "Whittier Birthplace" spoon made. ...

THE
PAIRPOINT MFG. CO.,
 New Bedford, Mass.

FINE
GOLD AND SILVER PLATED WARE.

OUR LARGE LINE
 OF
STAPLES
 AND
NOVELTIES

WILL BEAR INSPECTION.



No. 1250. CAKE BASKET.

Quality
 Guaranteed.

NEW YORK.

CHICAGO.

SAN FRANCISCO.

PHILADELPHIA

SOUVENIR SPOONS.

A FINE ASSORTMENT

OF THE

MOST ARTISTIC AND SALABLE DESIGNS.



DAVID F. CONOVER & CO.,

SEND FOR SELECTION.

PHILADELPHIA, PA.

particularly appropriate. The words New York are etched down the front of the shank of the spoon. The demand for this spoon, which is made at present for coffee only, is very large.

These three spoons include all those of a historical character. We will next consider the legendary, of which there is but one,

THE RIP VAN WINKLE.

Washington Irving's fine old story is brought forcibly to mind on sight of this spoon. The wayward Rip, whom the children and the animals loved so well, is seen rising after his long sleep in the mountains. He leans on his side, and his face depicts amazement at his surroundings. The long white hair falls over his face, while his clothes seem to fall off in pieces. Along the handle of the spoon lies the gun he took with him into the mountains, twenty years before. It is covered with rust and is broken from decay. New York is etched behind the leaning figure. The execution of the design is perfect.

These four designs are copyrighted by J. H. Johnston & Co., who control their manufacture and sale. Of spoons of municipal significance, the Gorham Mfg. Co. have produced seven designs, each remarkable in beauty and perfect in workmanship. They are designated by numbers from 1 to 7. Three of these designs are illustrated in this article, and the observer will readily understand why the demand for them has been heavy. The spoons may scarcely be con-

sidered objects of utility; but for real sentiment as mementos they are unexcelled. They are all approximately of the same size, namely five inches in length.

THE GORHAM NEW YORK SPOONS.

No. 1, as shown in the engraving, has the bowl composed of a real silver dollar hollowed or curved to something less than a semi-sphere. The coat of arms of New York State, representing a sailor and an Indian on each side of a shield, with an eagle at the top, forms the head of the spoon. The shank is a graceful stem spreading out into a leaf-shaped design, where it joins the bowl. The pattern is massive and rich, the workmanship being of the excellence which characterizes all the Gorham Co.'s productions.

No. 2 is essentially the same design, with a half-dollar substituted for the dollar. The effect is not so massive as in the former, but the feeling of richness is retained.

No. 3 combines the dollar bowl with a miniature of the Batholdi Statue of the Goddess of Liberty, forming the head of the handle. The history of this Statue requires no narration. Though considered by diletanti to be a monstrosity of art, it undoubtedly symbolizes the sentiments of all Americans, and its application to such an article as a souvenir spoon is particularly forcible. The miniature which is perfect in execution, stands on a capital of architectural design. In fact all the spoons partake of architectural significance, the shanks appearing like long columns.

No. 4 is to No. 3 what No. 2 is to No. 1, that is, it combines the miniature with a half dollar. The effect is the same as in No. 2.

No. 5 is the same as No. 3, with the exception of the bowl, which is composed of a dime in the centre surrounded by an odd and attractively fluted pattern. This design is perhaps as good as any in the set.

No. 6 is the same as No. 5, with the substitution of a quarter dollar, instead of a dime.

No. 7 is the same as the last three, with the substitution of the New York and Brooklyn Bridge for the coin. The depiction of that massive structure—the most gigantic engineering enterprise in the world—as seen in the engraving is perfect in detail. A description of the bridge is unnecessary here; those who have not rode or walked over it, are in a small minority, and they are familiar with its story and greatness.

THE WHITING NEW YORK SPOONS.

The New York spoons produced by the Whiting Mfg. Co., are all of local significance. The company produce three designs, the Brooklyn Bridge, the Statue of Liberty and Cleopatra's Needle. There is no die work in these spoons, the finest etching alone being employed. The spoons differ widely from the other company's, and possess individual beauties which accord them a ready sale. The bridge, obelisk or statue is etched on either the front or back of the spoon; if on the back, the words, New York, are etched

The R. Wallace & Sons Mfg. Co.,



No. 230 CUP. IN STERLING SILVER, TWO-THIRDS SIZE.

MANUFACTURERS OF

Sterling Silver, Plated Ware & Fine Cutlery

FACTORIES, WALLINGFORD, CONN.

{ New York Store: 3 Park Place.
Chicago Store: 104 State Street.



SOUVENIR SPOONS.

In answer to the demand, we have produced for the trade an unusually large number of odd and peculiar spoons, suitable as mementos of places and events, which have met with marked approval.

Historical, legendary and personal subjects have been successfully treated.

The dies for the patterns have, in a number of cases, been purchased by the dealer and protected by letters-patent, while in others, restrictions for certain cities have been given where the design has been suggested.

We are prepared to furnish estimates and designs for this class of work.

GORHAM MFG. CO.

Silversmiths,

Broadway and 19th St., New York.

on the handle, if on the front, the words are etched in the bowl.

In the Bridge design, the details are shown as from a bird's-eye view of the structure, all perfect in representation; the Statue of Liberty stands on the pedestal rising from Bedloe's Island. The same carefulness of detail characterizes the work in this spoon as in the other. The obelisk, the story of whose presentation to America is too well-known to bear repetition, stands as it seen from approach, the surrounding trees and shrubbery being accurately depicted. The souvenir conceit is combined with the Company's celebrated patterns, the heraldic, berry, lily-of-the-valley and Louis XV. The souvenir designs are applied to numerous other articles besides spoons.

The company are doing a very large business in souvenir spoons, securing orders all over the country. They also receive numerous orders for special work. One customer delivered thirty-eight spoons to the company for the purpose of having etched on them designs appropriate to various cities.

Tiffany & Co. are at work producing New York souvenir spoons, representing the Statue of Liberty, the Statue of Washington, etc.

Theo. B. Starr will shortly produce a New York spoon, but has not yet decided on the design. *(To be continued.)*

A new jewelry store has been opened in Seaforth, Ont., managed by C. L. Pabst.

Hussander's Assailant Proves to be a Murderer.

CHICAGO, Ill., March 18.—The arrest of Mike Silk, alias Erazin, alias Sholter, for participation in the attempt at robbery of L. F. Hussander's store, a few weeks ago, promises to result in an explanation of one of the most mysterious murders ever committed in the West.

Last May, Charles Poor, a well-known citizen of Omaha and Treasurer of the Laundrymen's Association, was found dead in that city, by an open window of his residence. About ten days ago the police in this city were informed that Silk was the man who had killed Poor. The informant said that Silk had confessed to him that he shot Poor while he was robbing the house, and that he was accompanied by a man named Henry.

Gold and Silver Antiquities for the World's Fair.

WASHINGTON D. C., March 19.—Lieut. H. B. Lemly, of the United States Army, the Special Commissioner of the Republic of Colombia in the interest of the World's Fair, reports that he has secured for exhibition a most remarkable collection of antiquities, which has been gathered by a famous collector of that country during the last thirty-five or forty years.

The collection includes many articles of gold and silver, of an intrinsic value of \$35,-

000, and the whole collection is estimated to be worth \$120,000. Included in the collection are a number of very curiously hand-worked gold articles found near the little village of Finlandis, situated in the valley of the River Viera, in Colombia, where some weeks ago two ancient towns of the Guaca Indians were unearthed.

Be Careful of Such Sneaks.

HAMILTON, Ont., March 18.—A young man named John Hyde was arrested here last week on suspicion of having stolen a watch from C. Moody, 13 York St. Last October, on the day of the robbery, while sitting at supper, Mr. Moody heard a noise in the front, and saw a young man run into the street. He gave chase and caught the thief, who said he only took one watch, which he offered to return, and begged so hard to be released that the jeweler gave him his freedom.

On his return to the store, however, Mr. Moody missed another watch. He has identified the prisoner as the man who stole the timepiece. Hyde is well-known in police circles.

Chambersburg, Pa., Feb. 22, 1891.

I owe the Circular a debt of gratitude for its optical articles, that I cannot repay. It has helped me in my studies more than I can express.

Geo. W. Ludwig.

SOUVENIR * SPOONS * IN * PIERCED * WORK.

THE FINEST AND MOST ORIGINAL STYLE.



Name of any city can be pierced in the handle like cut.

Also Etching on Bowl or Handle.

MYRICK, ROLLER & HOLBROOK,

MANUFACTURING SILVERSMITHS.

1018 CHESTNUT STREET, Philadelphia. Pa.

THE * MOLL * PITCHER * SPOON.

(REGISTERED TRADE MARK.)

Moll Pitcher, of whom the poet Whittier wrote, was a noted Fortune Teller of Lynn, many years ago.

In accordance with a popular fad, we have originated the "Moll Pitcher" Souvenir Spoon.



We are confident that there will be a large and immediate call for these spoons; already we are receiving orders from retail dealers in different parts of the country.

Our purpose is to furnish these to only one jeweler in each city or town, except in the larger cities.

Send postal card for Circular Price List and Terms.

W. F. NEWHALL, Jeweler,

52 MARKET STREET

LYNN, MASS.



Registered TRADE MARK.

A. Steinau Foils a Neat Crook.

CINCINNATI, O., March 18.—A quiet individual, of great dignity of speech and carriage, a few days ago presented himself at the office of the Union Savings Bank and Trust Co., in this city, and with the air of a multi-millionaire he made a deposit of five dollars, receiving a bank-book and a check-book to prove his business connection with the banking establishment. The depositor gave his name as James Henry, and address, 142 W. 4th St.

Mr. Henry later called at A. Steinau, Jr.'s store. His suave manner, gentle speech and prepossessing appearance were greatly in his favor, and salesman Herman Shockman treated him with the utmost politeness. Henry selected a gold watch and chain valued at \$63.00. In payment, the customer offered a check on the Union Savings Bank, proving his identity and honesty by producing the bank-book. There was only one entry in the book, which purported that Henry had deposited \$675. The \$5.00 had grown to so respectable an amount in so short a time.

The check was written out and accepted. The salesman noticed that one stub had already been used, and in all probability Mr. Henry had already caught one person. The goods were not turned over to the gentleman, however. He was politely asked to wait, as the check would be taken to the bank for certification. "Are you going right away?" asked Henry of the salesman. Receiving an affirmative answer, the stranger leisurely walked away from the place, promising to return in five minutes. He hasn't returned yet, but is promised a good reception if he will but show his face again.

The attempted swindle was exposed by the bankers, and the fact of the case as well as a description of the swindler, were immediately placed before Chief Deitsch. At the present writing the bank is \$5 ahead.

The Sensational Porteous Failure on the Tapis.

DENVER, Col., March 18.—Mrs. Denyse Rose Porteous was defendant this week on a complaint which charges her with having in her possession \$5,000 worth of jewelry belonging to her stepdaughter, Clara Bosworth, or Porteous. Numerous witnesses testified to her husband's business relations when interested in the "Diamond Palace." In this venture it was shown that he had invested about \$12,250 belonging to his ward. Later the "Diamond Palace" assigned to T. L. Drake. It is claimed that afterwards Mr. Porteous removed \$2,500 worth of diamonds and placed them in possession of his wife.

She and Mr. Porteous, said the woman, were married in April, 1889. She was formerly a Mrs. Boone. At one time she loaned Mr. Porteous \$5,000, alleging that she had about \$7,000 at the time. She acquired this money from her first husband, who was very wealthy. She took no security from her husband when she loaned him the \$5,000, but he gave her \$5,500 the day he failed.

ESTABLISHED 50 YEARS.

LANDEL, BAREMORE & BILLINGS,

IMPORTERS OF

DIAMONDS,

AND OTHER PRECIOUS STONES.

FINE PEARLS A SPECIALTY.

MANUFACTURERS OF

DIAMOND JEWELRY,

IN THE LATEST DESIGNS.

Diamonds Recut in Modern Styles or Repaired on Premises.

58 Nassau Street,
29 Maiden Lane,
NEW YORK.

1 Tulp Straat,
AMSTERDAM.

1 St. Andrews St.,
Holborn Circus.
LONDON, E. C.

ORIGINAL

GOOD FRIDAY NOVELTIES,

IN

STERLING SILVER.

FRANK H. LA PIERRE,

No. 18 EAST 14th STREET,

NEW YORK.

T. B. BYNNER,

Dealer in

Diamonds, Opals, Pearls,

AND EVERY VARIETY OF PRECIOUS STONES,

in varied and novel combinations.

177 BROADWAY,

NEW YORK.

LOUIS NEWMAN, JR.

GOLD AND SILVER

Plater, Fire Gilder and Colorer.

Gilding by a New Process. Watch Cases, Jewelry and Novelties, Work stands acids, and in finish equal to Gold.

36 & 38 JOHN STREET, NEW YORK.

FACTORY,
ST. IMIER, SUISSE.

HIPP DIDISHEIM,

83 NASSAU STREET,
NEW YORK.

IMPORTER OF WATCHES,

SPECIALTIES:

The "Nassau" the best imported movement in the market, fitting all American cases
The "Mignon," the best Chatelaine Watch for the money.
The "Gem," a high grade Chatelaine Watch with second hand, gold crown jewels in extra settings, etc.

If your jobber don't keep these goods, send to us and we will send you the address of one who does

A FASHION

may become

A FAD;

A CRAZE

will draw

A CROWD.

We will give you

A PROOF

of this

which will bring you

A PROFIT

if you will order a

tray of our

BIRTHDAY RINGS,

(PATENTED)

containing of assorted patterns, 148 Rings, four for each month, with appropriate stones and the sentiments thereof, printed upon the tray in gilt letters.

The Rings it contains are of our latest and most desirable styles and will be found always easy of sale.

*ORDER IT, DISPLAY IT, ADVERTISE IT LOCALLY AND
YOU WILL FIND THAT*

THE TIME IS RIPE.

M. B. BRYANT & CO.,

RING MAKERS.

10 Maiden Lane, New York.

Later she selected a quantity of bric-a-brac, but Assignee Drake would not allow her to remove it from the store.

The defendant denied positively ever having sold any diamonds under the name of Ardine Hamilton. In December, 1890, she purchased her present residence, paying \$4,740 therefor. The Margaret Porteous diamonds, jewels belonging to Mr. Porteous' first wife, the witness alleged had never been in her possession, although she had admired them when in her husband's safe. The jewels are now in possession of William Dingle, one of the bondsmen of the administrator of the estate of Margaret Porteous.

W. R. Perry, clerk of the County Court, testified to having received from the City Bank \$4,856.41 of the Margaret Porteous estate.

This practically concluded the case.

A Brazilian Diamond Redivivus.

PITTSBURGH, Pa., March 18.—James Smith, of Hempstead, has just discovered that a stone he had in his possession for over twenty years is a valuable uncut diamond. During a trip to Brazil in 1886, Mr. Smith found a curious stone which he brought to this country and has kept since. Some time ago he was attracted by the peculiar change which nature was working in the stone, turning it into thousands of brilliant points.

Upon trial he found it very hard, and no file could make the slightest impression on it. He submitted the stone to Prof. D. Lewis, of Duncannon, Pa., who pronounced the stone a cluster of diamonds worth at least \$14,000. The diamonds are very small, but their immense number makes their value very great. Mr. Smith has placed the stone in a safe deposit vault pending further investigation.

Imports and Exports for January, 1891.

WASHINGTON, D. C., March 19.—The summary statement of imports and exports of the United States for the month ending January 31, 1891, and for the seven months ending the same day compared with the corresponding periods of last year, issued to-day shows the following figures relative to the jewelry trade; imports, diamonds and other precious stones, rough and uncut, including glaziers' and engravers' diamonds not set, and jewels to be used in the manufacture of watches, month of January, \$62,813 to \$5,350 in 1890, a gain of \$57,463; for the seven months, \$456,273 against \$88,052, a gain of \$368,221; clocks and parts of, \$4,272 to \$16,504, a loss of \$12,232, and \$245,529 to \$328,892, a loss of \$83,363; watches and parts of, etc., \$125,490 to \$89,107, a gain of \$46,383, and \$1,236,224 to \$1,002,024, a gain of \$234,200; jewelry and manufactures of gold and silver, \$140,503 to \$123,467, a gain of \$17,036, and \$938,226 to \$797,219, a gain of \$141,007; precious stones and imitation of, now set, \$668,419 to \$730,593, a loss of \$62,174, and \$7,395,002 to \$7,097,012, a gain of \$297,990; bronze manufactures, \$44,299 to \$74,783, a loss of \$30,484, and \$490,541 to \$541,097, a loss of \$50,556

Exports of domestic merchandise, clocks, etc., \$91,675 to \$87,122, a gain of \$4,553, and 760,692, to \$788,930, a loss of \$20,238; watches, etc., \$82,777 to \$20,228, a gain of \$2,549, and \$169,055 to \$237,015, a loss of \$67,960; jewelry, etc., \$67,806 to \$46,539, a gain of \$21,267, and \$518,763, to \$344,503, a gain of \$174,260; plated ware, \$30,104, to \$32,357, a loss of \$2,253, and \$246,799, to \$280,441, a loss of \$33,642.

Exports of foreign merchandise, clocks, etc., for seven months, 11 to 147; watches, etc., for seven months, \$5,275 to \$960, a gain of \$4,315; jewelry, etc., \$7,120 to nothing, and \$11,517 to \$4,078, a gain of \$7,439; precious stones, etc., \$17,280 to \$7,390, a gain of \$9,890, and \$21,978 to \$51,843, a loss of \$29,865.

A comparison of the imports of the seven months ending January 31, 1891, as compared with the average of the same periods of the five preceding years, shows the following: clocks and watches, etc., increase, \$290,-875; jewelry, etc., increase, \$1,888,349. Exports, clocks and watches, increase, 79,417.

J. M. Seligman's Delicate Position

NEW ORLEANS, La., March 19. The committee which had charge of the movement against the men accused of the assassination of Hennessy is now investigating the jury, so as to learn if any of them were bribed.

The jurors will be summoned and will be asked to give their explanation of their verdict. Nearly all the jurors, including the foreman, J. M. Seligman, have made statements of what took place in the jury room.

Mr. Seligman, is out in a lengthy statement. After entering a general denial of the charges that he had been bribed, he gives expression to an opinion as to the positions occupied by judge and jury in a case of importance.

He says in addition: "I must acknowledge one fault. Through the inducements of kind, good friends, I was prevailed upon to leave the city when excitement ran high. Fortunately I was prevented. I was wrong in giving place to the idea. I have not left the city for one moment, nor do I intend to do so. I have remained in my apartments fearing violence, not desiring to give occasion for it."

He concludes by saying: "Despite the agony I have suffered, despite the vituperations that have been heaped upon me, I would not change my verdict unless the evidence was stronger, for I prefer to suffer these than the tortures of the thought of having sent a fellow-being to an untimely grave when in my soul and before my God I believed him innocent of the crime charged."

ULTRA-FASHIONABLE.

Mrs. CRESUS BULLION.—Oh, Mrs. Billsdoo, I must show you the souvenir spoons I bought at Moreham's to-day.

Mrs. BILLSDOO.—You are always in the fashionable swim, Mrs. Bullion.

Mrs. BULLION.—I try to be so. Now I must get my cook to serve up some nice souvenir.

USE THE  **AMERICAN MAINSPRINGS**
FOR ALL KINDS OF AMERICAN WATCHES.
[FACSIMILE OF WRAPPER.]

1 DOZ. MAINSPRINGS
18 S. E. O. S. 
Extra Quality.
TRADE  MARK.

THE BEST IN THE MARKET.

L. H. KELLER & CO.,

Dealers in Fine Watch Materials and Tools.

AGENTS FOR THE PATEK, PHILIPPE & CO. WATCHES.

64 NASSAU STREET, NEW YORK.

LEWIS BROTHERS,
Easter Novelties in Silver,
41 Maiden Lane, N. Y.

ESTABLISHED 1837.
GEO. O. STREET & SONS,
MAKERS OF
Fine Rings, Locketts, Seals, Sleeve
Buttons and Links,
15 John Street, - NEW YORK.

EZRA KELLEY'S
Famous Watch, Clock and Chronometer Oils,

RECEIVED AT THE
EXHIBITION UNIVERSELLE, PARIS, 1889.

The only Award of Merit given to Manufacturers of American Oils

It is to the interest of every Watchmaker to use in his work the *Best Oil* obtainable, regardless of cost. Mr. Kelley's claim to be the foremost manufacturer of Oils, giving the best results, is not based upon his own assertion, but is founded upon the fact that wherever his Oils have been exhibited in competition with other makes, subject to an examination of experts, they have received the highest *Award of Merit*.
For sale by all the Leading Jobbing Houses.

HENRY GINNEL & CO.,

GRIMSHAW & BAXTER, EUROPEAN AGENTS,
35 GOSWELL ROAD, LONDON. ENGLAND.

GENERAL AGENTS,
31 Maiden Lane, NEW YORK

BEST and CHEAPEST DEVICE FOR MAILING

All Mailable Matter at Cheap Postage.

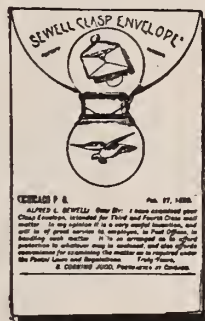

For mailing Trade Catalogues, Samples, Parcels of DRY GOODS, WOOL, YARN, COTTON, SEEDS, GROCERIES, PHOTOGRAPHS, DRUGS, WHEAT, FLOUR, GLOVES, LACES, RIBBONS, CALENDARS, SAMPLE CARDS, and all other 3rd and 4th class mail matter, is

SEWELL'S PATENT ENVELOPE CLASP,
(Patented in America and Europe.)

WHICH FITS ON ANY ENVELOPE IN THE MARKET.

In a moment it turns any envelope into a CLASP ENVELOPE. It is made of tough sheet brass. Anybody can put it on, as it is most convenient, and adjusts itself to a package of any size or thickness. It is endorsed by Postmasters.

We also make Envelopes, all sizes and kinds.
SAVE MONEY, and GET THE BEST, by writing for samples and prices to the

CHICAGO ENVELOPE CLASP CO.,
210 South Water St., CHICAGO, ILL., U. S. A.

ENVELOPES

FOR JEWELERS' AND OTHER TRADE CATALOGUES.

THE RYDER & DEARTH,
DESIGNERS & ENGRAVERS

Fine Commercial and Copper-Plate Printers.

A Specialty of

Jewelers' Printing, Cuts and Electrotypes.

Headquarters for JEWELERS' CARDS.

BEST WORK.

PROMPT DELIVERY.

LOW PRICES.

No Order Too Large! None Too Small!

146 Westminster Street,

PROVIDENCE. - RHODE ISLAND.



E. R. STOCKWELL,

MANUFACTURER OF

BADGES AND MEDALS IN GOLD AND SILVER,



E. R. STOCKWELL

19 John Street,

NEW YORK.

FOR ALL SOCIETIES,

INCLUDING

MASONIC

ODD FELLOWS,

GRAND ARMY.

Also for Schools.

BUTTON BADGES
IN SILVER OR GOLD.

Enameling and Repairing
for the trade.

19 John Street, N. Y.



ZIP!



Revolve these Rings in your mind, and you cannot help thinking of **OSTBY & BARTON**, the well known ring makers, 80 Clifford Street, Providence, Rhode Island.

**FASHIONS
in
JEWELRY**

A Lady's Ramble Among the Jewelers.

A novelty in silverware is a silver teapot lined with earthen ware.

Popular among medium priced brooches are the round and oblong shapes in twisted wire.

Trinket and powder boxes of silver, copying old ornaments, are decorated with medalion portraits.

The collars, leaders and harnesses for pet dogs are an important item in silver mounted leather goods.

A feature of the silver-bound prayer books and hymnals this season, is their comparatively small size.

An ostentatious but costly bracelet, is the one made of small flexible chain-bands, studded with diamonds.

An artistic necklace consists of a single row of pearls from which depend at intervals pink topazes and aquamarines.

To meet the present demand for Louis XV. fashions, are boudoir clocks in Vernis Martin, with crushed morocco leathers.

Shoe-buckles copying old-time French models are in moderate demand for shoes to be worn with evening costumes.

That coral is making some progress is intimated by rings seen, of beaten gold, in which were set five medium sized globes of coral.

Gold eggs of natural size in egg-shaped satin cases, afford luxurious bonbon boxes appropriate for Easter presentation.

Cleopatra's asp reproduced in brilliants, is a fashionable ornament for the hair; the Joan of Arc sword in diamonds, is another.

The new gold and silver-mounted leather goods represent crocodile, Brazilian lizard, pig, elephant and calfskins and morocco.

Numbered with chatelaine watches seen, are those in enameled gold cases that copy in form and color violins and mandolins.

Large gold headed pins are necessary adjuncts to a lady's toilette, and are worn well pushed in, leaving only the heads visible.

Ladies do not hesitate now to overload their fingers with rings, provided the rings are of sufficient beauty and costliness to excuse the display.

Easter book-marks consist of three narrow colored ribbons united by a silver bar at one end and decorated at the free ends with a silver cross, heart and anchor.

Ladies in mourning can make choice of onyx, hermatite and black enamelled jewelry. The onyx may be dull or polished, and settings of pearls or diamonds are allowable.

The remarkable fad for jeweled trimmings on bonnets and gowns has called out a bewildering variety of "stick-pins," which are worn wherever the taste or convenience of the wearer suggests.

A novelty in prayer books has its red Russia leather cover entirely overlaid with silver. This silver covering is diagonally divided into halves, one of which is beautifully etched in floral designs, while the other is in pierced work that discloses the leather underneath it.

"When the swallows homeward fly," is illustrated in a charming and expensive manner in a rivièrè for the corsage, consisting of five swallows in graduated sizes, mounted on spiral springs, and united into one flight by a flexible gold wire.

Men who pride themselves on having a fine collection of sticks, may be interested to know that the sticks carried by London swells are made of light malacca and have silver knobs. To make the collection complete, there should be at least one stick with a Dresden china handle.

The very newest "stick-pins" are those with heads considerably larger than the old bonnet pin, and designed to be thrust up to the head in the hair or fabric so as to show only the decorative portion; the effect is that of a flower, a star, a bee or other object without any visible fastening.

The very latest fad in jeweled trimmings are the spangle-like studs of faceted glass called cabochans by the French and known here as "nail-heads". These assume fanciful devices such as pointed stars, wafers, squares, and elongated diamonds.

ELSIE BEE.

Gus Beeler at Death's Door.

PITTSBURGH, Pa., March 18.—August Loch, Allegheny, Pa., has just received by telegraph the sad intelligence that Augustus Beeler, Hagerstown, Md., has had several hemorrhages of the lungs and could not live many hours. The invalid is a young man well known in this community, having formerly been in the employ of Hereen Bros. & Co., of this city, and later with the Dueber Watch Case Co., Canton, O.

Tiring of travel, he bought out a jewelry business about a year ago at Hagerstown, Md., where he has been very prosperous.

WILLIAM B. DURGIN,

Designer and Maker of Wares in STERLING SILVER,

CONCORD, NEW HAMPSHIRE,

Cautions Manufacturers against infringement of Orange Spoon Bowl, as shown in accompanying cut, as it is fully protected by Letters-Patent.



MANUFACTURER OF FINEST LINE OF ORANGE SPOONS ON THE MARKET.

BY SPECIAL ARRANGEMENT, CERTAIN PROPRIETORS OF SOUVENIR SPOONS ARE PERMITTED TO USE THIS BOWL.

MAKER OF PAUL REVERE, NEW HAMPSHIRE AND PRISCILLA SOUVENIR SPOONS.

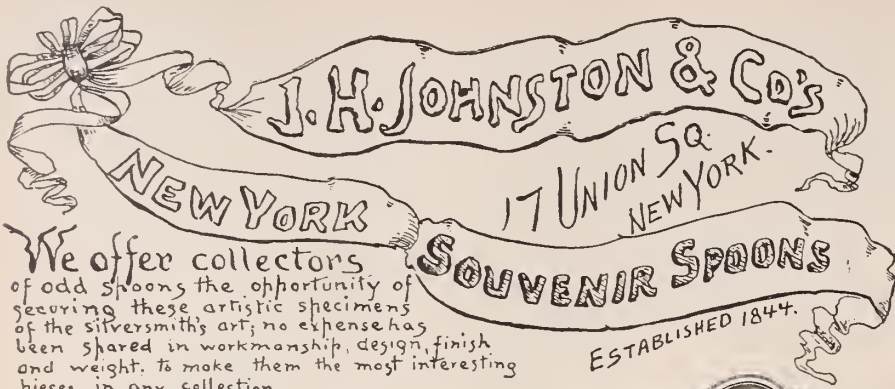

We offer collectors of odd spoons the opportunity of securing these artistic specimens of the silversmith's art; no expense has been spared in workmanship, design, finish and weight, to make them the most interesting pieces in any collection.

The back of each spoon is polished, suitable for monogram, crest or inscription.

These Spoons are Patented, and can be obtained only of us.

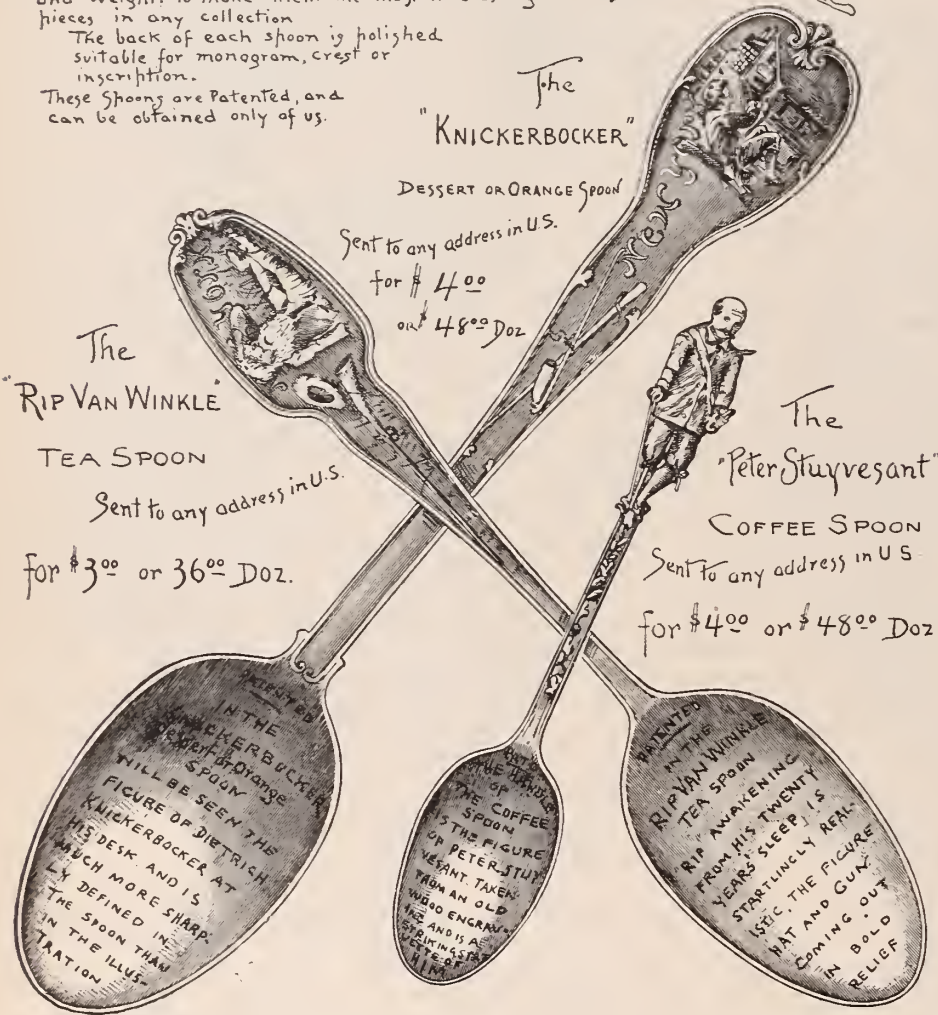

Discount to the Trade.

J. H. JOHNSTON & CO.

17 Union Square,

NEW YORK.



DEMAND FOR RUSSIAN DESIGNS.—FASHIONABLE DESIGNS IN JEWELLED BONNETS.—PAPER-WEIGHT CLOCKS.

PARIS, France, March 14th.—The visit of Hetman Atchinof has turned momentarily the attention of the buying public toward Russian fashions and styles. Some of our jewelers have brought to the front of their displays various articles, introducing expressionless portraits of saints, in translucent or cloisonné enamel, with frames or surroundings of filigree work; teaspoons decorated with piked niello ornaments of a moscovite character, etc. A Russian dépôt, established in the neighborhood of the Opera, is doing a good business. Visitors to that place admire greatly a silver tea-set looking as though it was made of netted tree-bark. The design of this service will appear original only to the few who have not seen what the Gorham Mfg. Co. have already produced in that line.

The lightest of bonnets is evidently a piece of tulle gracefully gathered so as to form in front, a bow-knot adorned with a slender diamond-sprinkled aigrette, that shoots sideways and slightly curls back over the thin material. Pretty bonnets in pale blue, or green tulle, so adorned have been fashionable for some time. I have seen a few enriched with sprays of flowers and insects made of rubies, emeralds, sapphires and diamonds tastefully arranged. A handsome hair-net for the night, consists of a close net-work of gold wire, with pearls set in every one of the intersecting points, yet, I am afraid it is more pretty than useful.

Some shops exhibit studs, brooches, etc., damascened, here and there, with small rubies and turquoises flatly incrustated.

I noticed at a well-known store a curious set. The bracelet and the necklace consist of two rows of crosses, the top row being made of a gathering of small opals, whereas the underneath is formed of brilliants. Tiny round pearls divide all those crosses. Short gold and silver chains, holding a watch that hangs from it, in the shape of a ball, either chased or decorated in filigree work, or paved with brilliants and other stones, etc., are becoming more and more fashionable.

The National Society of Fine Arts will, this year, allow a very important space in the Salon's rooms, at the Champ de Mars, for the exhibition of specimens of industrial art. Our artisans, silversmiths, keramists, enamelers, glassware decorators, etc., whose works will be found worthy of admittance, shall have then a splendid opportunity of calling to their artistic endeavors the attention of a numerous public.

News Gleanings.

L. Bock is out of business at Ennis, Tex.
 H. C. Sedgerbloom, Motley, Minn., has given up business.
 A. W. Kaufman has opened an attractive store at Tiro, O.
 Lion & Kylling have succeeded A. Blankenburg, Danville, Ill.
 Henry Stackman has succeeded C. R. Kenfield at Amherst, Mass.
 E. Parker has moved from Gaylord, Kan., to Smith Centre, same State.
 Hadwin & Knece have succeeded J. D. Hadwin, Ridge Spring, S. C.
 W. W. Hoover has moved from Penfield, Pa., to Caledonia, same State.
 M. B. Smith has moved from Pulaski, Tenn., to Murphysborough, Ill.
 M. Marshall, San Luis Obispo, Cal., has been succeeded by Marshall & Oppliger.

W. W. Fisher, Watsontown, Pa., will move to Sunbury, same State, on April 1.

Edholm & Akin, formerly jobbers at Omaha, Neb., are now located in Deadwood, S. D.

In a fire last Wednesday that destroyed the major portion of Highland, N. Y., Frank Prescott lost \$700.

G. W. Hickok & Co., formerly of Santa Fé, N. M., opened their new store at Albuquerque, same State, last week.

The store of A. S. Vaiden, Fordstown, Va., was recently broken into by thieves who carried off a lot of jewelry and other articles.

Whitman & Bristol, Beaufort, S. C., have been dissolved by mutual consent. W. R. Bristol continues the business under his own name.

Nash Mitchell, formerly superintendent of the Illinois Watch factory, has opened an agency for the Ceylon Planters' Tea Co. at 408 S. 6th St., Springfield, Ill.

D. H. Porterfield's store, Holyoke, Mass., was broken into recently, but the thieves were not well rewarded. Nothing was taken, but several opera-glasses, valued at \$3 or \$4 apiece.

On April 1 F. T. Koons will open business at the corner of Hamilton and Fountain Sts., Allentown, Pa., the present location of E. J. Faust. Mr. Faust will move to 715 Hamilton St.

The marriage of Gédéon Deriaz to Miss Mina Koehn, daughter of E. Koehn, formerly a member of the firm of Patek, Philippe & Co., Geneva, Switzerland, will shortly take place in that city.

Professor Charles Waldstein, the American archæologist, has had further success in his task of excavating hidden treasures from the ruins of Eretria, the city on the island of Eubœa (Negropont), which was founded before the Siege of Troy, and which was destroyed 490 B. C. by the Persians. He has found the ruins of a theatre, a number of graves, and treasures consisting of gold diadems, jewelry, vases, etc.

N. KOCH.

L. DREYFUS.

J. KOCH.

I. PFORZHEIMER.

KOCH & DREYFUS,

22 John Street, New York.

IMPORTERS OF DIAMONDS,

JOBBER'S OF

AMERICAN WATCHES,

Diamond Novelties and Jewelry

We have now a complete line of Goods and Specialties on hand and on the road in charge of following representatives :

JONAS KOCH, GEO. MALLET, L. GOLDSMITH,
 HENRY HEYMAN, A. ROSENTHAL.

THE LATEST PARISIAN NOVELTY.



MANUFACTURED BY
CROSSIN & TUCKER,
 409 Pine Street, Providence, R. I.

**TO THE TRADE.
 FINE WATCH REPAIRING**

BY
JOHN C. SIMMONDS,
 18 JOHN STREET. NEW YORK.
 New pieces, such as Chronometer Locking Springs, Balance Staffs, &c., made in the best styles. Watches sprung and adjusted to temperature and positions.



SEE THE NEW CUTTINGS
 FOR 1891,

CRESCENT



*The best American Cut Glass is that
 manufactured by*

THE PHENIX GLASS COMPANY,

OF PITTSBURGH, PA.

Unequaled in its BRILLIANCY, DEEP CUTTING and DESIGN.

729 Broadway, Cor. Waverly Place, N. Y.

43 SIXTH AVENUE, PITTSBURGH, PA

OPPENHEIMER BROS. & VEITH,

Diamonds, Watches and Jewelry,

2 Tulp Straat,
AMSTERDAM.

35 Maiden Lane,
NEW YORK.

We beg to inform the trade that we are still in a position to fill orders for

✂ DUEBER HAMPDEN WATCHES ✂

Of all grades, from stock purchased previous to the closing of the factories at Canton.

HAYDEN W. WHEELER & CO.,

2 MAIDEN LANE, NEW YORK,

Have an unusually large and varied stock of

FANCY STONE RINGS,

CONSISTING OF

MOONSTONE, GARNET, TOPAZ, AMETHYST, PERIDOT,
PEARL, DOUBLET, SARDONYX,

And the various combinations of these Stones.

DIAMONDS, ✂ WATCHES, ✂ JEWELRY.

WANTED, AN ADVERTISEMENT.

I will pay Fifty Dollars in cash to the Retail Jeweler who shall prepare the best worded and most effectively displayed advertisement of *Abbott's Patent Stem-Winding Attachment*, suitable for use in Magazines and Newspapers that reach the general public.

The advertisement to occupy a space of not more than two inches high by five inches wide.

The contest will close May 1st, 1891, and the prize will be awarded within ten days from that date.

**I WILL PAY
FIFTY
DOLLARS
IN CASH**

The following gentlemen will act as judges:

Mr. L. J. MULFORD,
Of The Jewelers' Circular.

Mr. ALBERT ULMANN,
Of The Jewelers' Weekly.

Mr. JOHN L. SHEPHERD,
Of The Keystone.

Circulars and descriptive matter supplied on application.

HENRY ABBOTT,

After May 1st, 14 Maiden Lane.

4 Maiden Lane, N. Y.

E. L. Ritch, Abilene, Tex., is dead.

Mrs. D. A. Parker has left Pawlet, Vt.

M. Versan, Roscommon, Mich., is dead.

F. E. Leitzelle has moved from Mifflinburg, Pa.

W. G. Stone has moved from Avon, Ill., and his present address is unknown.

J. Fish, Bryn Mawr, Pa., has returned from his trip to Europe, much improved in health.

The east side of the store of C. W. Griswold, Hornellsville, N. Y., will on April 1, be occupied by G. W. Griswold as a shoe store.

E. W. Davies, Athens, Pa., has sold out his business to W. A. Oakes, of Cattaraugus, N. Y., who will take possession in about a month.

The sixteen firms in the Attleboros, Mass., interested in the failure of Ehrlich Bros., Chicago, Ill., have only small claims against the firm.

C. C. Schellenberger, Washington, Ill., who proposed a watch factory for Dubuque, Ia., is now endeavoring to establish a factory in Freeport, Ill.

Fritz Moser, Jr., of the Illinois Watch Co. died suddenly last week, at Springfield, of heart disease. He was inspector in A room, was born at Chaux de Fonds, Switzerland, in 1866, and came to America in 1880, first locating at Rockford, Ill.

J. C. Amstutz, Fort Wayne, Ind., recently ordered six gold watches from a New York firm, and on last Tuesday received a box which contained a lot of papers and a bottle of patent medicine. The money which he had paid the express company for charges was replevined.

G. C. Shreve & Co., San Francisco, Cal., have given over a large portion of their mammoth store to an art exhibition for charity. Wealthy residents of San Francisco have loaned rare paintings for the exhibition, and for the next three weeks the store will be a regular Mecca for lovers of art.

The people of La Prairie, Minn., are exercised over the striking of hematite ore at a depth of fifty feet, in the Buckeye mine. The strike is rich and the ore plentiful, the drill having pierced through over four feet of it. It assays 62 per cent.

The Cowles Aluminum Co. have reduced the price of the metal to \$1.25 per pound.

Charles J. Hauck & Son, limited, of Brooklyn, N. Y., last Tuesday filed a certificate with the Secretary of State. The objects of the concern are to manufacture metal novelties and fancy metal goods. The capital stock is \$150,000, divided into 1,500 shares of \$100 each, and the incorporators are C. J. Hauck, Elise Hauck, William Schaefer, C. J. Hauck, Jr., and Joseph Fallert, Jr.

A dispatch received last Saturday from Madrid, Spain, said that the celebrated diamond necklace which was presented by Ismail Pasha to the Empress Eugenie on the occasion of the opening of the Suez Canal, and which was sold together with the rest of

the French crown jewels a few years ago. has been sold by a Madrid jeweler to an agent for an American lady for \$76,000.

A. Masters, Ponca, Neb., has sold out.

Zimmerman & Co., Selma, Ala., have sold out.

C. H. Hall, St. Andrew's Bay, Fla., has sold out.

T. A. Massie, Logan, Ia., has sold out to J. T. Ring.

F. F. Bonnett, Columbus, O., left for New York last week.

E. H. Higby, Perry, N. Y., will close out his business April 1st.

W. A. Coles & Co. have moved from Hartford, Conn., to Albany, N. Y.

John Nichlas, Baltimore, Md., has moved from 1612 to 501 W. Baltimore St.

L. C. Bradley has bought out the stock of the Norwalk Jewelry Co., Norwalk, O.

F. J. Kempel will, in a few days, move from Cawker City, Kan., to Oregon, Ill.

F. Neily, Baltimore, Md., has moved from 627 W. Baltimore St., to 717 Aisquitt St.

Silas Forsyth has moved from 634 Pennsylvania Ave., Baltimore, Md., to Black Creek, Ont.

L. A. Worch, the optician, Ft. Wayne, Ind., is having his new Calhoun St. quarters elegantly fitted up.

The wife of H. Kessler, Columbus, O., died at her home last week, after a long and severe illness.

Albert Schaub, Detroit, Mich., has just fitted up one of the handsomest stores in his line in this country.

M. Gansl, Grand Forks, N. D., has been appointed official watch inspector for the Northern Pacific R. R. Co.

F. A. Hubbard, Brattleboro, Vt., has bought out the silver plating business of W. W. Plimpton, in that town.

Andrew Jackson Duluth, Minn., has nearly completed the auction of his stock. He will retire from the jewelry business.

C. F. Mathey, of the Mermod-Jaccard Jewelry Co., St. Louis, Mo., has left that city for a trip to Europe on his semi-annual buying tour.

J. J. Harrison has bought an interest in the notions department of N. L. Jennings, Churdan, Ia. The jewelry department is retained by Mr. Jennings.

August Bruder, Ft. Wayne, Ind., presented to the Morton Club (Republican), at their last meeting, a very handsomely mounted mantle-piece clock.

The jewelers of Buffalo, N. Y., have agreed to close their places of business four evenings of each week from April first to September first, 1891.

Gerardo Nevraumont, the noted bandit, who some time ago entered a jewelry store in Chihuahua, Mexico, and, after killing the proprietor, robbed the store of a large quantity of diamonds and gold and silver articles has been captured.

Jos. M. Geist, Duluth, Minn., is in New York, where he has gone to buy an installment of next season's stock. During his trip he will stop at St. Paul, Chicago, Buffalo and other eastern cities.

Edward Byrnes, a silver-polisher, was arrested at 1047½ Fulton St., Brooklyn, N. Y., last week, on complaint of Henry J. Shirk, of 51 Clinton St., Newark, N. J., who charges him with stealing clothing valued at \$46. Byrnes was turned over to the New Jersey authorities.

Among the traveling salesmen in New Bedford, Mass., during the past week, were H. Weber, of H. Weber & Co., and M. Myers, of M. Myers & Co., Boston, Mass.; F. R. Holliston, of G. E. Luther & Co., Providence, R. I.; C. S. Perry, of Levy, Dreyfus & Co., New York; A. W. Winsor and Mr. Einstein, Attleboro, Mass.

J. H. Hart, Brooklyn, N. Y., accompanied by his wife and daughter left for Europe last Wednesday on a three months' trip. During the trip they will visit London, Paris, Nice, Genoa, Pisa, Rome, Florence, Venice, Vienna, Dresden, Berlin, Hanover and Bremen. Mr. Hart took a camera with him, which he proposes to use in taking copies and sketches of things he sees and places he visits.

One of the finest specimens of amethyst in the world is owned by Albertson & Chamberlain, stationers, of Duluth, Minn. The stone was found in the mines at Amethyst Bay, a point in the Thunder Bay district, a rich mining region on the north shore of Lake Superior. It is composed entirely of clusters of rich purple crystals of superior quality. The owners value the specimen at \$250.

Among the traveling men in Lancaster, Pa. during this week were D. W. Rosenthal, of the Attleboro Stock Co., C. F. Duffy, of Enos Richardson & Co., Chas. Noyes, of H. C. Haskell, Hugo I. Oppenheimer, of Weis & Oppenheimer, August Freund, of Max Freund & Co., Chas. Marx, of Levy, Dreyfus & Co., Max Eckstein, of Oppenheimer Bros. & Veith, and Louis M. Levy, Adolph Schwob, New York, Chas. H. Brown, of Van Houten Bros., Newark, N. J., and R. Williams, of the Philadelphia Optical & Watch Co., Philadelphia, Pa.

P. H. Wheeler will be the general superintendent of the watch factory at Los Gatos, Cal., to which place it has been decided to move the Otay watch plant. He is a gentleman about 45 years of age, and has had twenty-five years' experience in watch-making. He has been employed at the United States watch factory, the Rockford watch factory, the Illinois factory, the Columbus factory, and founded the Otay watch factory two years ago superintending the works from the laying of the first brick till the factory was closed. He is the owner of all the patents of the Otay Watch Co., and of course will use all of them in the factory at Los Gatos. The new factory will employ 100 men as soon as opened, and the number will be gradually increased as the demand requires.

D. T. Wood has opened a new jewelry store at Tehachapi, Cal.

Seng Bros. will open a fine store in Louisville, Ky., about April 1.

L. Stone has opened a watch repairing business at Susquehanna, Pa.

An auction sale is being conducted at the store of R. H. Kuhn, Quincy, Ill.

Sturgeon & Warren is the name of a new diamond firm opened at 17 State St., Detroit, Mich.

A. Schultz, son of G. A. Schultz, Louisville, Ky., has left for Europe to take a course in fine engraving.

J. W. Tyler formerly of Tyler & Anderton, Dayton, O., has returned from an extended eastern trip. He is contemplating moving to either Washington, D. C., or New York City.

The committee appointed to raise the amount required by the Manhattan Silver Plate Co., Lyons, New York., report that fifteen persons have pledged subscriptions to the amount of \$9,750.

Deputy Sheriff Luckner, of Minneapolis, Minn., has secured the jewelry which was stolen from J. M. Donelson, of that city by Louis Betts. The Chief of Police, who held the goods, was for a time in doubt what to do in the case, but finally turned over the diamonds to the sheriff.

C. G. Wilson, Ithaca, N. Y., who recently made an assignment, has liabilities of \$7,260.27; nominal assets, including fixtures (\$1,500) are \$4,926. His largest creditor is Mr. Clark, of Nourse & Clark, Cortlandt, N. Y., who offers to buy up the other creditors' accounts at 30 cents on the dollar to facilitate a settlement.

Will Leave the Pulpit for the Counter.

JANESVILLE, Wis., March 17.—Rev. O. F. Elliott, pastor of the All Souls' Church here, will leave this city on May 1, and go to Manchester, N. H., where he will take charge of the jewelry store of W. H. Elliott, his father.

Mr. Elliott, who has attended to business for many years, wrote to his son and requested him to return and take charge of the business. The Rev. Mr. Elliott's son, Ralph Elliott, is also a jeweler, and is at present employed in A. F. Hall & Co.'s store, in this place. He will accompany his father.

The Gloversville Burglars on Trial.

JOHNSTOWN, N. Y., March 19.—The County Court opened Monday, with Judge Keck on the bench. Tom McAveney and "Biggy" Donovan, indicted for robbing the store of A. D. Norton, Gloversville, last June, were brought down shackled together. McAveney's New York attorney, J. O. Keene, is assisted by Anibal & Murray. District Attorney William Green is assisted by A. J. Nellis. The defense moved to quash the indictment. Ex-Judge Anibal was before the forestry investigation at Albany, and the court adjourned to Tuesday, when the case will be moved for trial.

A jury was procured this afternoon.

We have increased our line of **HOWARD WATCHES** by recent large additions, and our stock is now as complete as can be found. We carry every grade in Hunting and Open Face, 18 and 16 size, in various weights of Jürgensen style E. T. cases (14 K. and 18 K.), with and without lips, with and without glass caps under the gold caps, with "regular" pendants and oval or "antique" pendants; also in plain polished cases, plain engraved, "top and bottom" engraved, bascine engine-turned, richly engraved, diamond set, and all the staple and many unique styles. Selection packages sent to responsible regular jewelers on request.

Bowman & Musser,

Importers and Jobbers,

Watches, Chains, Spectacles, Tools and Materials,
Lancaster, Pa.

SOMETHING • NEW.

ALUMINUM THIMBLES.

Light, Durable and will not tarnish.

In appearance similar to Silver, and at half the cost.

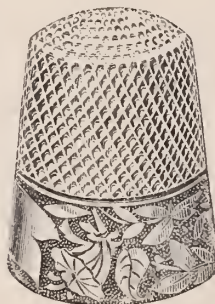

If you want something NEW, HANDSOME and CHEAP, send, enclosing business card, for samples and prices.

KETCHAM & McDOUGALL,

198 Broadway, New York.

A Wonderful TOOL FOR THE BENCH.

Instantaneous in Its Work.

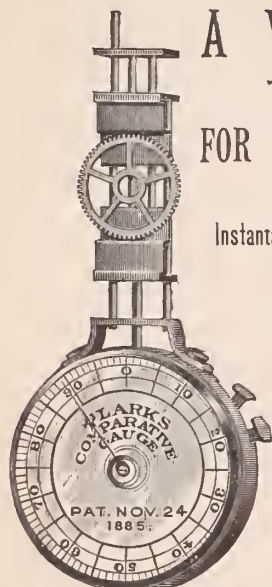

Dividing the inch into one thousand parts. A most practical tool for watchmakers for gauging from a hair-spring to a main-spring. Non-comparable for a height and depth gauge. Instantaneous for hair-spring work.

For sale by all Jobbers.

NORDMAN BROTHERS,
120 Sutter St., SAN FRANCISCO, CAL.
Sole Agents for the United States.

The New Trenton



18 SIZE, SEVEN JEWELS, NICKEL.
HUNTING AND OPEN FACE S. W.

Quick train, straight line lever escapement, safety centre pinion, enamel dial, beautifully damaskeened and exceedingly attractive in appearance.

THE BEST LOW PRICED WATCH EVER PRODUCED.

For Sale by the Jobbing Trade.

TRENTON WATCH CO.

TRENTON, N. J.

E. R. Kant Examined in Court.

CLEVELAND, O., March 19.—E. R. Kant who last week made an assignment, presented himself in the Probate Court this morning and submitted to an examination on the motion of one of his creditors. It came out in the examination that just before assigning he had executed and recorded a number of chattel mortgages preferring certain creditors and it also developed that he had contracted certain of his debts in the name of the estate of his father, the late W. B. Kant. Judge White reserved his decision. There have been conflicting decisions of Ohio courts with reference to executing chattel mortgages in contemplation of an assignment.

A quit claim deed given by Mr. Kant to Mrs. Casper Baumann, Mrs. William Ingram and Mrs. F. C. Graf, was recorded Thursday. It releases all his (Kant's) interest in 232 feet on Courtland St., for \$400.

Fire and Water do Damage in Maiden Lane.

The factory of J. H. Kimball on the third floor of 14 Maiden Lane, New York, was burnt out last Tuesday evening involving a loss of about \$1,000 which is entirely covered by insurance. It was shortly after 7 o'clock when smoke was seen issuing from the windows of the workshop. An alarm was immediately sent out, but owing to the firemen being engaged on the conflagration in the dry goods district it was some time before a stream of water was directed into the factory which was then beginning to blaze fiercely. In less than ten minutes the fire was extinguished. Mr. Kimball was telegraphed for and an investigation was made. It was found that the fire had started near the furnace.

When seen by a CIRCULAR reporter Mr. Kimball stated that when his workmen closed the place at six o'clock everything appeared safe. He used gas in the furnace and he was wholly at a loss as to how the blaze originated. It will be two weeks before he is able to resume business as most of his machinery was destroyed.

Water from the fire did considerable damage to the stock of the T. A. Willson Optical Co., whose offices are directly under the burnt-out factory. Mr. Willson told THE CIRCULAR representative that it will be some weeks before he is able to estimate the damage done to his stock as every day he is finding goods which have rusted from the water and dampness. Water also fell into the office of Bruhl Bros. & Co., but did no damage.

Three Well-known Criminals Jailed.

CLEVELAND, O., March 20.—Three of the most notorious jewelry thieves that have been arrested in this city in many years, were placed behind the bars at the Central Station Wednesday night.

On the afternoon of the day previous, two young men walked into A. D. Ernie & Co.'s

store, 94 Euclid Ave., and told Mr. Erne that they were of a committee of three railroad men appointed to purchase a watch to be presented to an engineer who had resigned from the road.

After looking carefully over the stock of watches, they said that they would call again at 7 o'clock on Wednesday evening with the third man and make a purchase. Mr. Erne was suspicious, and immediately informed the police. Accordingly, shortly before the hour mentioned three detectives stationed themselves in and about the store.

The "committee" drove up in a buggy at the appointed hour. One entered the store while the others remained in the buggy. While still engaged in examining the watches, the detectives secured the two men on the outside, who started to open fire, but were covered with pistols just in time. The third man was then arrested. At the station they registered as Mike Coleman, Thomas Fox and John Harris. Coleman is known about town as "Blinky Mike, the thief." Fox, say the officers, served a term in the penitentiary. Harris is a stranger in the city, and claims to hail from Cincinnati. A box of cayenne pepper and a box of soapine were found on the latter's person.

The three suspects were arraigned yesterday morning. The cases were continued until to-day. They were committed in default of bail, of \$500 each.

After their cases were continued, the station was crowded with people who had jewelry stolen from their stores and residences, to look at the prisoners and see if they could identify them. Among the curious was E. L. Wilsdorf, the jeweler, 1115 Lorain St., who was so boldly robbed of several hundred dollars' worth of watches at dusk on the evening of February 7. After looking at the three men

he identified "Harris" as one of the men who were in his store on the evening of the robbery. He said that Harris, to the best of his knowledge, was the man who stood watching at the door. The police are also in possession of a telegram from Detroit stating that Harris is well known there.

A Comedy of Errors Ended in Court.

PROVIDENCE, R. I., March 19.—There has just been settled in the Supreme Court of this State, a case entitled William Bonner *et ux* vs. Ralph Orr *et al*, which closes the history of one of the most complicated and peculiar cases ever experienced in the jewelry business, and one which has been watched with unusual interest by those conversant with the facts.

Early in 1878, Ralph Orr and George A. Schuyler started in the manufacturing business at Pawtucket, under the style of Orr & Schuyler. Matters progressed regularly and their business had been fairly prosperous until early in 1887 when the concern became involved in internal dissensions from some unknown reason, and for nearly six months the old tradition of the Kilkeny cats was re-enacted, and one of the most ludicrous succession of incidents occurred that can well be imagined. One partner would place an extra lock on the door, whereupon the other would break into the shop and recriminate by putting on a fastening of his own. This continued for some time, when matters were brought to a focus by an assault case wherein each was in turn plaintiff and defendant.

This apparently forced a settlement, for the next chapter in this comedy of errors is opened July 6, 1887, by the appearance of a new actor, William Bonner, who purchased Mr. Orr's interest and the firm became

CROSS & BEGUELIN,
21 Maiden Lane, N. Y.



MAKERS OF THE
CENTENNIAL TIMERS
AND
CENTENNIAL CHRONOGRAPHS.
IMPORTERS OF
DIAMONDS,
Watch Material, Opera Glasses, etc.
JOBBER'S OF ALL GRADES OF
AMERICAN WATCHES,
Gold and Rolled Plate Jewelry.

We carry a large stock—and are constantly adding all the LATEST designs of goods in our several departments—so that we are enabled to fill ALL orders with PROMPTNESS, which most dealers will appreciate.

Selection Package Sent on Satisfactory Reference.

SEND FOR PRICE LIST.

NOTICE.

The undersigned having purchased the interest of Mr. GEORGE OWEN in the firm of G. & S. OWEN & Co., have this day formed a new co-partnership under the firm name of SNOW & WESTCOTT, for the purpose of continuing the business heretofore carried on by the late firm of G. & S. OWEN & Co.

JAMES P. SNOW,
CHARLES E. WESTCOTT.

March 2, 1891.



THIS is a facsimile of the copyrighted label in colors, attached to every ream of genuine ROYAL GRASS BLEACHED SILVER TISSUE PAPER manufactured by us, and guaranteed absolutely pure. Its reliability as a wrapping for solid or plated goods is conceded by all who have used it, while the price is considerably less than is asked for foreign paper of this class. To determine the relative merits of our paper as compared with the imported tissue, we will gladly furnish samples, free of charge, to all manufacturers who may desire to test it. ROYAL GRASS BLEACHED SILVER TISSUE is sold by all paper dealers in the U. S. Write us for samples.

MILLS:
MILBURN, N. J.
HAMPTON, N. Y.
WHIPPANY, N. J.
PATERSON, N. J.

MANUFACTURED BY
DIAMOND MILLS PAPER CO.,

44 Murray Street, New York.

WATCH DIALS.

Any kind watch dial duplicated within ten days. Factories supplied with dials for their entire product or with special designs for their high grade movements. Special rates for large quantities. Emblems, photographs, landscapes and ornamental work of every description on plain, enamel or under glaze.

WALTHAM DIAL CO.,
WALTHAM, MASS.

A. J. GROENMAN & CO.,
DIAMOND CUTTERS,
80 NASSAU ST., N. Y.
WE MAKE A SPECIALTY OF SEL
LING FINE, SMALL MELEES

Schuyler & Bonner. But matters did not appear to have been changed for the better, for in less than a year Bonner commenced suit against Orr for damages on the ground that the latter had misrepresented the business to him, Bonner, and that Orr was in league with Schuyler to defraud the plaintiff. This assertion created bad blood between Schuyler and Bonner and in consequence the business was sold by a master of chancery at the legal dissolution of the firm, and was bought in by Frank Page, of Boston, Mass., for Mr. Schuyler.

Amicable feelings having been restored the firm once more became Orr & Schuyler, this time however, acting as agents, while at the same time, the suit of Bonner against Orr was still pending. About September, 1889, Mr. Orr withdrew from the firm since which time Mr. Schuyler has conducted the business alone.

The case at litigation was heard in the Supreme Court at a recent date and a verdict rendered in favor of Bonner; during this week the court has assessed the damages at \$1,842 and judgment rendered for that amount.

Charles Heizman's Schedule is Filed.

The schedules in the assignment of Charles Heizman, 459 3d Ave., New York, who failed two week ago, were filed Friday. They show the liabilities to be \$3,121.69 with assets worth \$2,569.00. Among the creditors appear the following firms in the trade.

Adolph Goldsmith, Arthur Van Benschoten, Oppenheimer Bros. & Veith, Waterman & Lehmann, H. S. Herzog, L. Sauter & Co., F. H. Westover, the Ansonia Clock Co., A. Wittnauer, M. Miller, Joseph Lassner, C. C. Haensler, Joseph Friedlander, Adolph Bernhard, H. C. Heistail, H. H. Henrich, Ludwig Lehmann, H. M. Davis, Champenois & Co., Fisher & Sons, Julius King Optical Co., and T. A. Beguelin, New York, Van Houten & Bros., Newark, N. J., Simons, Bro. & Co., Philadelphia, Pa., and the Miller Bronze Co., Brooklyn, N. Y.

Attorney Mahony, of Temple Court, the legal representative of Mr. Heizman, told a CIRCULAR reporter that an offer of settlement would probably be made in a few days.

An Insane Jeweler Disturbs Passengers.

ST. LOUIS, Mo., March 17.—There was an exciting scene on the east-bound Louisville and Nashville train which reached this city yesterday morning. Shortly after leaving Ashley, Ill., a man sitting in one of the front coaches threw his hands to his head and cried, "Oh, my God! Oh, my God!" When asked what was the matter he said he was very sick. A moment later he got up and started toward the door saying he had to get off. The train was going at the rate of thirty miles an hour. One of the passengers stopped him and he was taken back to his seat. Twice again he tried to get out on the platform to jump from the moving train,

and it took the combined exertions of trainmen and passengers to prevent him from doing violence to himself.

The man had paid his fare to Belleville, Ill., and left the train at that point. His name, it was learned, was Wm. Wangelin, and he was formerly a jeweler in that city. For some cause his wife left him. His mind became affected and he was sent to the insane asylum at Anna. During his absence his stock of jewelry and other property was disposed of. A short time ago he was released from the asylum, being apparently cured, and it is supposed that his mind again became unbalanced while on the train.

Canada Produces an Elegant Silver Piece.

MONTREAL, P. Q., March 23.—Henry Birks & Co., of this city, have just finished a most elaborate piece of work. It is a solid silver punch-bowl, fifteen inches high, two feet in diameter, and valued at \$1,000. The article which has been in course of construction for six weeks, was presented on Saturday to W. W. Ogilvie, head of the great Canadian flour milling syndicate.

The design contains engravings of half a dozen of the firm's branch offices and mills as well as the new Montreal headquarters. It is decorated with tassels of wheat, in a way at once delicate and realistic. The crests of the Provinces engraved on shields form another feature of the bowl. The ladle represents a bunch of wheat. The bowl is ensconced in an oak case.

ESTABLISHED 1841.

CARTER, SLOAN & CO.

MANUFACTURERS OF

FINE JEWELRY,

15 MAIDEN LANE, NEW YORK.

A. CARTER, JR.
A. K. SLOAN.
C. E. HASTINGS.
GEO. R. HOWE.
WM. T. CARTER.



Factory, NEWARK, N. J.

Boston.

Nelson H. Brown, 90 Franklin St., is on a pleasure trip to Washington.

Henry Cowan has purchased from the trustee, Uriah Case, the plant of C. G. Hall, Hartford, Conn.

O. A. Drinkwater, of Morrill Bros. & Co., is in the South for the benefit of his health. He will remain in Florida for a month or more.

Notices have been issued by the American Waltham Watch Co., that the stockholders' annual meeting will take place March 26, at the treasurer's office.

F. C. Kibby, Chelsea, Mass., has sold out his business to A. F. Johnson and G. L. Kerr, who have been employed at the American watch factory, in Waltham.

Insolvency proceedings were advanced one stage further in the case of C. T. Seaverns & Co., the diamond merchants, at the session of the Court in Dedham, this State, last Wednesday.

W. H. Wheeler, of Springfield, Vt., and J. A. Merrill, of Portland, Me., were in town on a buying trip during the week. Mr. Merrill controls the Longfellow souvenir spoon, named in honor of the poet, who was born in that city.

President C. F. Morrill, of the Bay State Watch Case Co., who is an enthusiastic lover of the ocean, is having built a handsome schooner-rigged yacht which will be launched about the middle of May. The *Navarch* will be 65 feet in length and will be perfectly equipped, and handsomely finished.

Travelers in town for the week were: D. P. Mygatt, of J. F. Fradley & Co., Robert Hamilton and Benj. Griscom, New York; George Caldwell, of the Plainville Stock Co., Plainville, Mass.; J. F. Imfeld, of O. A. Hendrick & Co., and George Paine, North Attleboro, Mass.; George Hutchison, of Providence, R. I.; Emile Block, Attleboro, Mass.; C. R. Cobb, Pawtucket, R. I.

Canada and the Provinces.

A. Kent, of Kent Bros., Toronto, Ont., was in Whitby a day last week.

A. McCarter, Ingersoll, Ont., is improving the front of his establishment and has erected a handsome new street sign.

R. J. Hall formerly in the employ of the late Robert Kenley, Ottawa, Ont., has opened a jewelry store in New Westminster, B. C.

C. D. Reymond, watchmaker, who has for twenty-five years been with John Leslie, Ottawa, Ont., has opened a store in the same city at 154 Rideau St.

Macdonald, who was arrested in January for stealing jewelry from C. E. Jacque's store, Calgary, Man., was tried there last week and convicted. Sentence was deferred, as there was another charge against the prisoner in connection with the robbery.

W. T. Hayes, alias S. W. H. Beauregard, convicted of the robbery of Birks & Co.'s store, Montreal, P. Q., in connection with

Nellie Carr, an account of whose trial was published last week, was sentenced to seven years in the penitentiary, the same term as his companion got.

Cleveland.

Baxter & Beattie, successors to Baxter & Craig, are consolidating their three stores into the one at 118 Arcade.

G. A. Craig, formerly of Baxter & Craig, left last week for West Virginia, to enter on his new duties as railroad contractor.

Webb C. Ball has made arrangements to enter upon a ten years' lease of the building

in which his store is now located, at a rental of \$8,000 a year. He will build an additional story on the building, put in a new front and lay a new cement sidewalk.

T. H. Graham has tendered his resignation as an assignee of Sumner Bros., and Mr. Burdick, of the Bowler & Burdick Jewelry Co., has been substituted as trustee.

The case of Smith & Greene, Providence, R. I., against Sipe & Sigler, was brought up for trial Friday morning. The plaintiffs sue for \$6,362.92 for goods sold and delivered. The defendants assert that the claims are worthless, and file a cross-petition for \$16,000.

HOW A JEWELER MAY BECOME AN OPTICIAN.

It is to many a matter of surprise that such a large proportion of the young people we meet are wearing Spectacles.

An important question is suggested: Do they really need glasses, or is it a kind of fashion or fad? In view of this state of things it is necessary that some RELIABLE person in each place should be competent to decide who require glasses and the kind that should be worn.

It is natural for people to go to the Jeweler to have their eyes fitted, as they wish to avoid the expense of getting a prescription from the oculist unless there is a diseased condition of the eyes. No one can correctly prescribe glasses unless he has received instruction as to how the different defects of vision can be detected and know at once the remedy. To be able to do this it is not necessary to take a regular medical course. If you desire to know how instruction may be received in fitting eyes in a PRACTICAL and SCIENTIFIC manner, JEWELERS are requested to address for full particulars

JULIUS KING OPTICAL CO.,
CLEVELAND, OHIO. | **4 MAIDEN LANE,**
NEW YORK.

To those who cannot take the time to attend a course of lectures, we have arranged a system of PRIVATE INSTRUCTION.

Providence as Affected by Failures.

PROVIDENCE, R. I., March 20.—The manufacturers in this city are beginning to feel that this season will be fully up to the average as to the number of failures and financial embarrassments and the amount of money involved. Already two or three manufacturers have been obliged to make assignments.

The members of the Manufacturing Jewelers' Board of Trade are interested in the Ehrlich Bros.' failure to the extent of \$11,000 to \$12,000.

The stone dealers in this vicinity lose about \$500 or \$600 by the failure of E. G. Biber & Co., of Attleboro, Mass., who has made an assignment to John P. Bonnett.

E. R. Kant, Cleveland, O., who last week made an assignment to Hamilton Roosa as reported in THE CIRCULAR, had creditors in this city to the amount of about \$500 to \$800.

The offer of Frank D. Enney, Syracuse, N. Y., of 25 per cent., 12½ per cent. cash payable May 1, 1891 and the balance in six months' notes dated from April 15, 1891, and indorsed by his wife, did not meet with favor among his Providence creditors but his last offer, 25 cents cash, is meeting with considerable favor.

The affairs of Henry Read, 40 Potter St., are in a much more complicated condition than was at first thought. The mortgage of \$1,500 given Aug. 24, 1887, to J. H. Read will eat up all the assets and will not allow any of the other creditors to participate in a settlement unless the mortgagee sees fit to diminish his claim sufficiently to allow the others an opportunity of receiving something and thus give Mr. Read a chance to engage once more in business.

Davenport, Ia.

The first aluminum watches to appear in this city are being shown by Mrs. T. Kircher.

Stark & Ruser, are steadily increasing their stock and during the past week have added another large show case to their fixtures. This addition has been an annual event with them ever since they established their business here.

Commercial travelers visiting this city last week were: T. R. Barnes, of the Hartford Silver Plate Co., D. W. Wiser, of Heintz Bros., Buffalo, N. Y.; E. R. Grow, of Smith & Knapp, J. A. Griffin, of A. Peabody & Co., A. Gunzberger, of Gunzberger Bros., and V. Watros, of H. M. Smith & Co., New York; S. L. Burgess, of the E. A. Bliss Co., Meriden, Conn.; H. Schmidt, of Swartzchild & Co., and Max Noel, of Stein & Ellbogen, Chicago, Ill.

Notice is given of a sharper operating from town to town in Iowa. His plan is to go to a town, rent a furnished room in a nice respectable locality, go to a livery stable and procure a horse and buggy, paying in advance, saying he will return later, and then to drive to some jewelry store and select a number of

fine articles of jewelry and request that the clerk, a boy or somebody be sent with him to his rooms to make selections. Then when getting to the room Mr. Sharper slips out the back way with the goods and the jeweler has to take his chances and very seldom catches the confidencer. This man is undoubtedly the thief whose operations in St. Louis THE CIRCULAR recounted a few weeks ago.

Royal Battle With Burglars.

PITTSBURGH, PA., March 22.—Three months ago Rupert's jewelry store, in Homestead, Pa., was robbed of several thousand dollars' worth of goods by a man and a woman, and the case was placed in the hands of a detective agency in this city. The detectives located the supposed thieves, and at 7 o'clock last evening Chief Detective D. H. Gilkerson and his assistant, P. J. Murphy, went to Bull Run, a small mining village near McKeesport, to arrest a man named Fitzsimmons suspected of the burglaries.

The moment the officers entered Fitzsimmons' house and arrested him, his wife from the folds of her dress handed her husband a self-cocking revolver. Fitzsimmons began shooting at once, and at the first shot Gilkerson fell dead with a bullet in his brain. There was a regular fusillade between Detective Murphy, Fitzsimmons and his wife, which continued until their weapons were emptied. When the firing ceased Fitzsimmons was lying on the floor, bleeding from several wounds, while Detective Murphy was also badly hurt and somewhat dazed. The woman stood by like an infuriated animal at bay uninjured with an empty pistol in her grasp. A crowd soon collected. Detective Murphy placed Mrs. Fitzsimmons under guard and she was taken to McKeesport jail.

Before Detective Murphy had fully recovered from the shock and excitement, Fitzsimmons jumped from the room and under cover of the darkness made his escape to the mountains. A search party was organized, which overtook the fugitive near Homestead.

Detectives have spent most of to-day in searching in the house where the shooting occurred and in the neighboring country. They found a satchel belonging to Fitzsimmons secreted in a hollow log about a quarter of a mile from the house.

It was filled with several thousand dollars' worth of valuable jewelry, which is claimed to be that taken at the Homestead robbery. Fitzsimmons probably took the satchel with him when he ran from the house, but finding it too heavy to carry hid it in the log.

The authorities here are talking of sending a special engine and car to-night to bring Fitzsimmons down here for safe keeping, as they fear to leave him over night in the Homestead lockup.

A Woman's Daring Theft.

ST. LOUIS, Mo., March 21.—Kate Burg, a resident of Kansas City, this State, who has been in St. Louis about one week, went into Henry Vost's store, at 1403 Olive St., yester-

day afternoon and asked to be shown a pair of diamond earrings. The proprietor showed her a pair worth \$30, and she began to examine them, leaving her pocketbook, abnormally puffed, lying on the counter. After examining the diamonds some time she made an excuse that she wanted to see the diamonds in better light and moved toward the door. As soon as she reached the door she rushed out into the street and ran west to 15th St. and then turned north. It was some time before the clerk discovered that she had disappeared, but when he did he opened the pocket-book and found that it was stuffed with stones bound in a handkerchief. Then clerks James McIntyre and Hutchings Clark started out in pursuit. After a long chase they captured the woman at 15th and Morgan Sts. She was brought back to the store and turned over to the police.

Philadelphia.

Louis A. Scherr & Co. on Thursday received a stock of Waltham movements for the new 16-size pendant-set case.

Louis Sickles, of M. Sickles & Sons, started on Sunday for a trip through Pennsylvania. Although Mr. Sickles has traveled extensively for other houses, this is his maiden trip for the firm of which he was recently made a member.

Among the out-of-town members of the trade who visited the city during the week were Stephen Avery, of the Waltham Watch Company, New York, G. A. Schlechter, Reading, Pa., T. Ecaubert, New York and Harry Pyewell, Chester, Pa.

Bernard Levy expects to have on the market in two weeks a stock of cases for the new 16-size pendant-set Waltham movements. The same house is getting ready a new 6-size pendant-set case that will hold either Waltham or Elgin movements.

F. Dutton, a pawnbroker doing business at 1600 Passyunk Ave., and W. H. Osbourne, his clerk, were before Magistrate Durham, on Friday, charged with the larceny of a diamond earring, valued at \$125. The plaintiff charged that a valueless stone had been substituted for a diamond in a ring pledged. The defendants were held in \$600 each for trial.

The beautiful country seat, "Hylstye," which C. N. Thorpe, President of the Keystone Watch Case Co., of this city, has had built at Devon, will be ready for occupancy in a short time. The house is beautifully situated, on an eminence commanding a view of from five to fifteen miles in every direction. Mr. Thorpe will spend the coming summer there.

The jobbing jewelers of this city held their annual meeting at Guy's Hotel on Friday. Simon Muhr, president of the association, presided, but the meeting resolved itself into an executive session, and nothing connected with the business transacted was made known, except that D. F. Conover was elected president, and G. W. Scheer re-elected secretary and treasurer.

Connecticut.

G. H. Wilcox, of the Meriden Britannia Co., and wife, are back to their home at Meriden, from their trip to Chicago.

The store of the late A. D. White, in Waterbury, was closed on Saturday night. Mr. Cummings, the manager of the store, returns to his home near Providence, R. I.

Martin Cooper, New Haven, has been obliged to change his quarters, owing to the failure of the concern who shared with him the rental of his old stand. He is now still more centrally located, on Chapel St., between Church and Orange Sts.

Twenty-one years ago last Tuesday, the Meriden Silver Plate Co. started business in Meriden. From a small beginning, with a dozen employees, they have prospered, until to-day they have 300 employees. The officers took a mental retrospect on that day, in view of the company's 21st birthday, with very satisfactory contemplations.

The old clock of the Terryville Congregational Church, referred to recently in THE CIRCULAR, has been overhauled and repaired and now keeps good time. A new wheel, a few slight repairs and a thorough cleaning were only necessary to rejuvenate this fine time-piece. Although it began its second half-century of service in somewhat of a hurry, gaining over half an hour the first day it ran, at present it is better regulated.

An explosion occurred on Friday at the Derby Silver Company's factory, Birmingham, causing much excitement and consternation for a time. The fire alarm bells were rung and a great crowd collected. A compressed air machine had given way with a deafening report, and fragments of iron and steel were sent flying in all directions. Fortunately, all the hands being away at dinner, there was no loss of life or injury to any person.

Irwin Chambers, who for many years conducted a jewelry store in South Manchester, while driving his well-known trotter Green Mountain Daisy in that town last Wednesday, attempted to pass in front of a railroad train which was just starting. The puffing locomotive started the horse to one side, throwing Mr. Chambers to the railroad track just in front of the locomotive. The engineer stopped the train in time, but Mr. Chambers was rendered unconscious by his fall for hours, and it is feared his skull is fractured.

Rochester.

Oakes & Calhoun, dry goods dealers, have put in an elegant line of ladies' jewelry.

B. E. Brown has a demand for gemmed aluminum rings, which he has recently brought out.

Morris Present is preparing a full line of samples, and will take the road for Philip Present, April 1. He will travel in this State and Pennsylvania.

Bowen & Hoyer, have placed a chronometer in front of their store, which is utilized by passers-by for regulating their time-pieces.

THE "WITCH" SPOON

(Registered Trade-Mark.)

From the old Witch Town of Salem.

One of the first and best known of the Souvenir Spoons.

These spoons have been advertised extensively, and having received hundreds of mail orders coming from every state and territory, we know there is a demand for them in all parts of the country, and that you would find a ready sale for them.



MADE IN Sterling Silver ONLY.

The design on the handle is raised.

ORANGE SPOON, No. 1. (Exact Size.)

- Coffee Spoon, - - \$1.25
- Coffee Spoon, gold bowl, - 1.50
- Tea Spoon, - - - 2.00
- Tea Spoon, gold bowl, - - - 2.50
- Orange Spoon, No. 1, - - - 2.25
- Orange Spoon, No. 1, gold bowl, - - - 2.50
- Dessert Spoons, Sugar Spoons, Almond Scoops, &c.

THIS PATTERN CAN BE OBTAINED ONLY OF US.

DISCOUNT TO THE TRADE.

DANIEL LOW,

Jeweler and Silversmith,

ESTABLISHED 1867.

SALEM, MASS.

Jules Jürgensen

OF COPENHAGEN.

The reputation these watches have maintained for Fifty Years has never been equalled, being made on strictly scientific principles, and no expense spared to give the Best results in mechanism and timekeeping qualities.

SOLE AGENTS,

John C. Hyde's Sons,

No. 22 MAIDEN LANE.

RUSSELL HOUSE, DETROIT, MICH.

Always a Favorite of the Jewelers, for the following (three) reasons:

1st—Excellence of its cuisine. 2d—Its central location to the trade they visit. 3d—Ample security its spacious vaults offer for samples and valuables.

CHITTENDEN & McCREARY, Prop'rs.

S. C. JACKSON, 180 BROADWAY, NEW YORK,

MANUFACTURER OF

Fine Cases for Jewelry, Silverware, Etc.,

ALSO SHOW CASE TRAYS AND FANCY HARD WOOD WORK.

Samples sent on application. Estimates furnished.

"THE PLYMOUTH ROCK SPOON."



PATENT APPLIED FOR.

No collection of Souvenir Spoons complete without one from Old Pilgrim Plymouth.

THE SPOON has on the handle in raised figure, an exact fac-simile of the world-famous Rock on which our fore-fathers landed in 1620.

MADE IN

Orange, Sugar, Tea and Coffee Sizes,

IN STERLING SILVER ONLY.

SOLD ONLY BY

GOODING BROS.,

PLYMOUTH, MASS.

Write for Prices.

SOLID SILVER COFFEE SETS.



AFTER DINNER

COFFEE POTS.

ODD AND UNIQUE DESIGNS.



TURKISH, MOORISH

AND OLD ENGLISH

DECORATIONS, WITH SUGAR DISH,
TONGS AND TRAY TO MATCH.



GORMAN MFG. CO.,

SILVERSMITHS,

Broadway and 19th St.,

NEW YORK.

ALFRED H. SMITH & CO.,

DIAMONDS,

182 BROADWAY,

COR. JOHN STREET,

NEW YORK.

33 HOLBORN VIADUCT, LONDON, E. C.

THE JEWELERS' CIRCULAR

AND

HOROLOGICAL REVIEW.

PUBLISHED EVERY WEDNESDAY BY

THE JEWELERS' CIRCULAR PUB'G CO.,

AT NO. 189 BROADWAY, NEW YORK CITY.

A JOURNAL DEVOTED TO THE INTERESTS OF WATCHMAKERS, JEWELERS, SILVERSMITHS, ELECTRO-PLATE MANUFACTURERS AND ALL WHO ARE ENGAGED IN KINDRED BRANCHES OF INDUSTRY.

Terms of Subscription, Postage Prepaid.

	PER ANNUM
United States and Canada, - - -	\$2.00
To all Foreign Countries, - - -	4.00
Single Copies, - - - - -	.10

ADVERTISEMENT.

Business letters, drafts, checks and post-office orders should be addressed to THE JEWELERS' CIRCULAR PUBLISHING COMPANY, No. 189 Broadway, New York city.

Manuscript from any quarter containing news or discussion of any technical subject within the field covered by THE CIRCULAR will be welcomed. Matter received that proves unsuitable or unavailable will be returned if accompanied by the necessary postage stamps.

Our editorial columns will contain our own opinions only, and we shall present in other columns only what we consider of interest or value to our readers. Applications to print advertising matter as news will not be considered.

Advertising rates in THE CIRCULAR are lower, considering the number of tradesmen reached by its large circulation, than in any other jewelry journal.

Notices of changes in standing advertisements must be received one week in advance, new matter can be received up to Saturday.

Member of the American Trade Press Association.

CLASSIFIED INDEX TO ADVERTISERS, PAGE 28.

VOL. XXII. MARCH 25, 1891. No. 8.

NOTICE.

New subscribers are taking advantage of our combination premiums to a gratifying extent, and to the mutual advantage of all concerned. The offer is an unusually good one, and it is no wonder that it is meeting with such prompt recognition. Subscribers will please bear in mind that it takes from two to three days to select and forward the premiums.

Souvenir Spoons. PERHAPS the history of silverware manufacture affords no instance similar to the present demand for souvenir spoons. From every point of the country the cry comes and silversmiths are encroaching upon the limits of their facilities to satisfy it. Though the fad is but in its youth, almost every city has a representative spoon, and the list is being daily added to. Progressive jewelers need no urging to take the opportunity while it offers; they appreciate the axiom that if a dealer denies novelties to his customers, they will in turn deny him patronage for staples. But there is a minority of the best houses who prefer to handle only a limited number of souvenir spoons, the productions of one or two manufacturers. Place this class in juxtaposition with those who carry a com-

plete assortment. The first displays a half dozen articles from which it may be difficult to select with satisfaction; the second, a large number, fifty to a hundred or more, that may afford pleasure even in the very inspection of them. The one may receive an order through conservative reasons; the other will receive an order through the thorough satisfaction his stock gives. Does not the success of the latter class rest on the stronger foundation? And it is with the conviction that the fashion is a boon to the trade, that THE CIRCULAR has commenced a series of articles, in which will be included all the souvenir spoons manufactured throughout the country; the material already collected will necessitate the series being run through several numbers, and it is hoped that they will prove an impetus to every dealer to produce and control a spoon characteristic of the town in which he is located. THE CIRCULAR invites correspondence from all dealers who control a souvenir spoon.

That Wrong Taxation Measure.

THE Linson bill (Senate Bill No. 107) repealing in the case of the taxation of personal property, exemption for debts, is meeting with active opposition from numerous merchants throughout the State. It is not right that our legislators should pass laws that will drive our manufactures and commerce to New Jersey which by its more liberal treatment of corporations has already attracted many New York business men. Merchants and manufacturers do business largely on credit, the cash capital being but in small proportion to the magnitude of their transactions. The commission on the volume of their business is but small, and to tax them on their debts would simply mean a shrinkage in the commercial transactions, and in consequence, the agricultural and real estate interests of the State. The New York Board of Trade and Transportation and several organizations of the drygoods, grocery and lumber industries are leagued against the passage of the measure; the New York Jewelers' Association and the New York Jewelers' Board of Trade should add their voices to the cry of opposition.

Knowledge of Jewelry Fashions.

THE bold assertions regarding jewelry fashions made by writers for the daily newspapers are a constant cause of disturbance to the equilibrium of the jeweler's peace of mind. Upon the mere statement of an unauthoritative person or upon the conclusion in his or her own mind based on a superficial observation, the writer will boldly recount the decadence of this or that class of jewelry. The press is as omnipotent as human enterprise can be. The great mass of people mould their ideas from the columns of their favorite papers. It would, therefore, seem impossible to counteract the effects of the writings of the class of scribblers referred to. Yet if every dealer would endeavor to have republished in the columns

of his local newspaper, the fashions contained in each number of THE CIRCULAR, the unwarrantable assertions would receive some check. THE CIRCULAR endeavors to have the fashions reprinted in the daily papers of the large cities, and seeks the co-operation of the dealers in the smaller places, in giving the general public an authentic conception of the reigning fashions in jewelry.

The Week in Brief.

The Porteous failure came up in the courts at Denver, Col.—A. Steinau, Jr., Cincinnati, O., foiled a smart crook.—The Treasurer's report of imports and exports for January, 1891, was issued.—J. M. Seligman, New Orleans, La., issued a statement.—Gus. Beeler, Hagerstown, Md., was reported to be at death's door.—Frank Prescott lost \$700 by the fire at Highland, N. Y.—L. C. Schellenbergen, the so-called watch factory promoter, wants a watch factory at Freeport, Ill.—Charles J. Hauck & Son, Brooklyn, N. Y., was incorporated.—A celebrated piece of the Crown Jewels was sold.—The assailant of L. F. Hussander, Chicago, Ill., proved to be a murderer.—Arrangements were made for a display of gold and silver antiques at the World's Fair.—A sneak thief was captured at Hamilton, Ont.—The annual stockholders' meeting of the American Watch Co., was decided to take place March 26.—Henry Cowan, Boston, Mass., bought out the plant of C. G. Hall, Hartford, Conn., who recently failed.—Nellie Carr's accomplice was sentenced at Montreal, P. Q.—Smith & Greene, Providence, R. I., vs. Sipe & Sigler, Cleveland, O., was brought up in the latter city.—A trustee was substituted for T. H. Graham, assignee of Sumner Bros., Cleveland O.—E. R. Kant, Cleveland, O., was examined in court.—A fire on Maiden Lane, New York, did some damage.—Three crooks were captured in Cleveland, O.—The Meriden Silver Plate Co., Meriden, Conn., reached their majority.—An explosion in the factory of the Derby Silver Co., Birmingham, Conn., did little damage.—Charles Downs' plant, Providence, R. I., is advertised for sale.—News was received in Providence, R. I., of the death of Albert Smith.—The suit of Peter B. Simons & Son, San Francisco, Cal., vs. the Elgin Watch Co., will be called in a few days.—Alexander Osborne, an old-time refiner, died at an almshouse in Newark, N. J.—The store of J. H. Ayars, Wilmington, Del., was robbed.—The Bonner-Orr-Schuyler case was decided at Providence, R. I.—Charles Heizman, New York, filed his schedule.—Wm. Wangelin, formerly a jeweler at Belleville, Ill., went insane on a train.—Detectives had a royal battle with burglars at Pittsburgh, Pa.—Henry Yost, St. Louis, Mo., encountered a female pilferer.—Frantz Lebkuecher, Newark, N. J., died.

SEE OUR INDUCEMENTS TO NEW SUBSCRIBERS ON PAGE 37.

New York Notes.

J. R. Rothschild will shortly open an optical store at 86 Wall St.

Henry Fera has been confined to his house during the past few days, suffering from the grippe.

A. J. Churchill, chronometer manufacturer, 62 South St., is selling out preparatory to closing up the business.

Herman Goldsmith, 33 John St., sailed for Europe on the *Harve* last Wednesday, to sell to the American trade in London.

Marie Celeste, wife of Leon J. Glaenger, of Leon J. Glaenger & Co., died last Friday at her residence, 110 E. 31st St.

The firm of Moore & Horton, 11 Maiden Lane, has been dissolved, and the office fixtures, tools, etc., are advertised for sale.

The following jewelers sailed for Europe during the past week: Judah Hart, New Orleans, La.; C. C. Camerden, of Camerden & Forster.

This afternoon, auctioneer J. H. French will begin to sell the stock of M. Panon, 931 Broadway. The articles to be sold consist of clocks, bronzes, onyx cabinets, lamps, artistic novelties and bric-a-brac.

R. & L. Friedlander, 65 Nassau St., were notified last week that J. T. Bolling, who kept a small store at Wake Forest, N. C., had committed suicide by shooting himself.

The firm of E. D. Anrich & Co., 24 Maiden Lane, was recently dissolved by the retirement of E. M. DeFleece. E. L. Anrich will continue the business in liquidation.

C. W. Schumann's Sons, 17th St. and Union Square, deny that they intend moving from their present location. They emphatically denounce the originator of the report to that effect.

E. C. Baldwin has been engaged to represent on the road the newly-organized firm, Riley-Klotz Mfg. Co. The concern, of which Samuel Klotz is President, will make the same line of goods as their predecessors, the Riley-Osborn Mfg. Co.

By a fire which broke out in the Howard Building, 176 Broadway, last Thursday, the offices of the Howard & Son Co., the E. A. Bliss Co., Bugbee & Niles and Sandland, Capron & Co., were somewhat damaged. The glass flooring of the offices of the three last named firms was entirely demolished by the firemen in their efforts to reach the blaze. The fire, which was confined to the basement and the furnishing store of Harris & Bros., did not interfere with the business of the many jewelers in the building.

Last Monday Judge Ingraham of the Supreme Court handed down a decision denying the motion of the Paillard Non-magnetic Watch Co. to set aside the judgment obtained against that concern on Feb. 12, in favor of Charles McCulloh, receiver for the Non-magnetic Watch Co. This judgment enjoined the Paillard company from selling any watch movement having the name "Non-magnetic Watch Company of America" or any such inscription, and further ap-

pointed James J. Nealis as referee to hear testimony on the damages plaintiff is said to have suffered during the litigation.

The capital stock of the Crescent Watch Case Company has been raised to \$100,000.

I. Lewkowitz, accompanied by his daughter, is visiting relatives and friends at San Francisco, Cal.

Secretary H. M. Condit, of the New York Jewelers' Board of Trade, has been away from his office during the past week on jury duty in the City Court.

The man Wright or Evans, mentioned in connection with the Staten Island mystery which is at present interesting the people of the country, is said to have been a diamond cutter in Hatton Garden.

James W. Hagan, who recently severed his connection with James W. Miller, 37 Union Square, has opened an office at 47 Maiden Lane. Mr. Hagan will import diamonds and manufacture mountings and fine jewelry.

The suit of F. A. Bratt, a lawyer of Port Edward, N. Y., against Aikin, Lambert & Co. for fees in connection with the failure of

J. A. Wilson, as reported exclusively in THE CIRCULAR, two weeks ago, was closed last Saturday before Referee Norfolk, of Sandy Hill. The hearing of the testimony in a similar suit against J. T. Scott & Co. will be heard next Saturday.

H. A. Herbert, of the New York Jewelers Association, was last week granted a copyright on a postal card for the use of traveling men from which he has great expectations. It is intended to bear the daily report of a traveler while on the road and from the few firms to whom Mr. Herbert has exhibited his invention he has received the most encouraging comments.

Last Wednesday Deputy Sheriff Bartow sold a portion of the property of Viemeister Bros., at 13 Willoughby St., Brooklyn, to satisfy a judgment for \$494.05, obtained by H. Henrich, 35 Maiden Lane. The goods, which were sold by Auctioneer Kerrigan and brought good prices, were nearly all purchased by E. C. Viemeister under the initials "M. C." The business of the Viemeister Bros. is still being continued on Manhattan Ave., Greenpoint, L. I., under the name of the wife of one of the former firm.

JEWELERS ATTENTION!

DO YOU KNOW that we are making the only line of cuff buttons which are sold exclusively to the RETAIL JEWELRY TRADE?

DO YOU KNOW that the action or fastening of this button is the simplest, most durable and most salable of any in the market?

DO YOU KNOW that we are manufacturing a full line of these buttons in roll plate, gold front and solid gold?

DO YOU KNOW that this line of buttons was endorsed and recommended by the OHIO RETAIL JEWELERS' ASSOCIATION?

DO YOU WANT a line of cuff buttons which is not found in any Dry Goods, Gents' Furnishing or Millinery Store in the country—thereby preventing such ruinous competition?

Then send to us for a selection of our "ANTI-SWEAR" Buttons

J. T. SCOTT & CO.,

SOLE MANUFACTURERS,

4 MAIDEN LANE, - NEW YORK.

Syracuse.

H. C. Smith, who was burned out in the recent fire, has bought the fixtures and lease of Elmer E. Clark, jeweler, 301 E. Genesee St., where he has resumed business. It is understood that Mr. Clark was backed by F. D. Enney, who failed last week.

The stock of the Standard Watch Co., which was destroyed by fire last week, was valued at \$40,000, and was insured for \$22,000. The three safes belonging to the company have been recovered from the ruins. One of them was filled with jewelry, another contained \$8,000 worth of unfilled orders, which were recovered and will be filled as promptly as possible. The company place their loss at about \$15,000 above insurance. They have leased rooms in the Klein Block, 226 and 228 James St., where they are continuing business.

Kansas City.

Henry Bliss, of Krementz & Co., Newark, N. J., and Mr. Peabody, of A. Peabody & Co., New York, were in town on Saturday last.

The new souvenir spoons are selling well. The first line was put in a show window two weeks ago, and since then have had a ready sale. Some of the spoons have the name of the city etched in the bowls.

For the past week an auction has been held each morning at the store of M. B. Wright & Co. The stock is being reduced preparatory to the removal to the new store, 1034 Main St., which will be opened about April 1.

O. Kolstad, Pleasant Hill, this State, was in the city a few days ago, showing patent-letters for a new device in tweezers for setting roller jewels. He expects to manufacture the new tool for the trade. Mr. Kolstad learnt watch-making with Jules Jürgensen.

A Massachusetts Dealer Burnt Out.

SOUTH FRAMINGHAM, Mass., March 18.—Fire broke out in Smith Block, the largest business structure in town, at 3 o'clock this morning, but prompt and efficient work by the firemen confined it to comparatively small limits. J. W. Bacon, jeweler, lost from \$500 to \$1,000, covered by insurance.

Decided to Auction off the Lancaster Factory.

LANCASTER, Pa., March 22.—The real estate and machinery, together with the stock on hand of the Lancaster Watch Co., of this city, will be sold at assignee's sale on the premises on Thursday, April 16. The plant will be sold subject to a mortgage of \$50,000, due in July, 1896. The factory is completely equipped with the latest improved and finest machinery for the manufacture of watches, and in the hands of proper parties would prove a valuable investment.

Jas. A. Freeman & Co., of 422 Walnut St., Philadelphia, are the auctioneers. Catalogues may be had of the assignee, D. Ramsay Patterson, Drexel Building, Philadelphia.

DORFLINGER'S AMERICAN CUT GLASS.



TRADE MARK.

The Finest Crystal, Plain and Cut, made in the World.



TRADE MARK.

EVERYTHING that is used in Glass, for the Table.

Sells as well as Silver-ware.

EVERY FIRST-CLASS JEWELER

C. DORFLINGER & SONS,



BEAUTIFUL, Artistic and Useful Pieces for Gifts.

Rivals the Diamond for Purity and Lustre.

SHOULD KEEP IT.

36 Murray Street, New York.



Fleur de Lis "VICTORIAS."

WE ARE SHOWING THE

Most Popular Line

IN THE MARKET.

H. F. BARROWS & Co.,

1½A Maiden Lane, N. Y.

JOHN A. RILEY & SLOAN CO.,

860 BROADWAY, NEW YORK.

EASTER NOVELTIES,

INCLUDING

ROSARIES AND CRUCIFIXES IN GOLD AND SILVER.

ALSO HAIR PINS, TIARAS AND A GENERAL LINE OF GOODS FOR LADIES' WEAR.

JAMES P. SNOW.

ESTABLISHED 1834.

CHAS. E. WESTCOTT

SNOW & WESTCOTT,

SUCCESSORS TO G. & S. OWEN & CO.

MAKERS OF

FINE JEWELRY,

Lace Pins, Ear Rings, Scarf Pins, Sleeve Buttons, Sash Pins, Collar Buttons, Bracelets, Studs.

All Goods sold by us are exclusively of our own manufacture and are warranted 14 K. Fine, and stamped as such when possible.

No. 3 MAIDEN LANE, NEW YORK.

CLASSIFIED INDEX TO ADVERTISEMENTS.

All Advertisements are entitled to one insertion under proper heading. Extra insertions, \$6.00 per Annum. Extra Headings \$12.00 per Annum.

	PAGE.		PAGE.		PAGE.
Assayers & Refiners.		Horological Schools.		Silk Guards.	
Howard, S. P., 8 John st., N. Y.....	48	Elgin Horological School, Elgin, Ill.....	47	Rosentall, Wm., 79 Nassau st., N. Y.....	41
Lelong, L., & Bro., Newark, N. J.....	48	Waltham School of Horology, Waltham, Mass.....	40	Silver Plated Ware.	
Platt, Chas. S., 31 Gold st., N. Y.....	48	Hotels.		Pairpoint Mfg. Co., New Bedford, Mass.....	5
Robertson & Leber, 13 Franklin st., Newark, N. J.....	48	Russell House, Chicago, Ill.....	23	Rogers, Wm., Mfg. Co., Hartford, Conn.....	44
Auctioneers.		Imported Clocks, Bronzes, Etc.		Rogers & Hamilton Co. The, Waterbury, Conn.....	48
Comrie, A. J., 16 West 125th st., N. Y.....	44	Glaczer, L. J., & Co., 80 Chambers st., N. Y.....	31	Rogers & Bro., 16 Cortlandt st., N. Y.....	46
French, J. H., Box 2775, N. Y.....	35	Jewelry Repairers.		Stem-Winding Attachments.	
Badges, Medals, etc.		Wiederhold, A., 20 Maiden Lane, N. Y.....	42	Abbott, Henry, 4 Maiden Lane, N. Y.....	16
Stockwell, E. R., 13 John st., N. Y.....	12	Jewelry and Silverware Cases.		Sterling Silver Novelties.	
Black Onyx Jewelry.		Jackson, S. C., 180 Broadway, N. Y.....	23	Alvin Mfg. Co., 860 Broadway N. Y.....	42
Woglom, Gilbert T., 32 John st., N. Y.....	40	Jobbers, Watches, Diamonds, etc.		La Pierre, F. H., 18 East 14th st., N. Y.....	9
Books, Stationery, etc.		Aikin, Lambert & Co., 23 Maiden Lane, N. Y.....	38	Lewis Bros., 41 Maiden Lane, N. Y.....	11
Chicago Envelope Clasp Co., Chicago, Ill.....	11	Beguelin, Tell A., 71 Nassau st., N. Y.....	40	Sterling Silverware.	
Cut Glass.		Bowman & Musser, Lancaster, Pa.....	18	Durgin, W. B., Concord, N. H.....	13
Dorflinger, C. & Sons, 36 Murray st., N. Y.....	27	Conover, D. F. & Co., Philadelphia, Pa.....	5	Gorham Mfg. Co., 19 st. & Broadway, N. Y.....	7, 24
Mt. Washington Glass Co., New Bedford, Mass.....	41	Cross & Beguelin, 21 Maiden Lane, N. Y.....	19	Towle Mfg. Co., Newburyport, Mass.....	35
Phoenix Glass Co., 729 Broadway, N. Y.....	15	Friedlander, R. & L., 65 Nassau st., N. Y.....	40	Wallace, R. & Sons, Mfg. Co., 3 Park Place, N. Y.....	6
Diamond & Precious Stone Importers.		Koch & Dreyfus, 22 John st., N. Y.....	15	Wood & Hughes, 16 John st., N. Y.....	47
Fera, Her., 50 Maiden Lane, N. Y.....	47	Myers, S. F. & Co., 48 Maiden Lane, N. Y.....	48	Souvenir Spoons.	
Gunzburg & Sons, 35 Maiden Lane, N. Y.....	48	Scott, J. T. & Co., 4 Maiden Lane, N. Y.....	26	Dole, H. L., Haverhill, Mass.....	4
Hedges W. & Co., 170 Broadway, N. Y.....	39	Yates, John B., 147 Nassau st., N. Y.....	47	Gooding Bros., Plymouth, Mass.....	23
Kahn, L. & M. Co., 10 Maiden Lane, N. Y.....	48	Musical Boxes.		Hudson, H. G., Amesbury, Mass.....	4
Kipling, E. E., 10 John st., N. Y.....	48	Jacot & Son, 298 Broadway, New York.....	40	Johnston, J. H., & Co., 17 Union Square, N. Y.....	14
Kipling, R. A., 31 Union Square, N. Y.....	39	Optical Goods.		Low, Daniel, Salem, Mass.....	23
Lorsch, Albert & Co., 37 Maiden Lane, N. Y.....	48	Geneva Optical Co., 23 Washington st., Chicago, Ill.....	39, 40, 4	Moore & Leding, Washington, D. C.....	31
Oppenheimer Bros., & Veith, 35 Maiden Lane, N. Y.....	16	King, Julius, Optical Co., 4 Maiden Lane, N. Y.....	21	Newhall, W. F., Lynn, Mass.....	8
Randei, Baremore & Billings, 29 Maiden Lane, N. Y.....	9	U. S. Optical Co., 17 Union Square, N. Y.....	44	Sterling Silver Souvenir Co., Boston, Mass.....	32
Smith, Alfred H. & Co., 182 Broadway, N. Y.....	24	Order Work.		Thimbles.	
Taylor & Bro., 860 Broadway, N. Y.....	46	Maxheimer & Beresford, 3 Maiden Lane, N. Y.....	39	Ketcham & McDougall, 198 Broadway, N. Y.....	18
Wheeler, Hayden W. & Co., 2 Maiden Lane, N. Y.....	16	Tissue Paper.		Tool Manufacturers and Dealers.	
Diamond Cutters.		Diamond Paper Mills, 44 Murray st., N. Y.....	19	American Watch Tool Co., Waltham, Mass.....	33
Groenman, A. J. & Co., 80 Nassau st., N. Y.....	19	Pens, Pencil Cases, Etc.		Bullock, O. W. & Co., Springfield, Mass.....	40
Diamond Jewelry.		Aikin, Lambert & Co., 23 Maiden Lane, N. Y.....	38	Nicholson File Co., Providence, R. I.....	29
Bynner, T. B., 177 Broadway, N. Y.....	9	Ring Makers.		Nordman Bros., San Francisco, Cal.....	18
Falkenau, Oppenheimer & Co., 40 Maiden Lane, N. Y.....	48	Bowden, J. B. & Co., 192 Broadway, N. Y.....	45	Watch Companies.	
Ludwig, Nissen, & Co., 18 John st., N. Y.....	42	Bryant, M. B. & Co., 10 Maiden Lane, N. Y.....	10	Non-Magnetic Watch Co., 177 Broadway, N. Y.....	38
Stern Bros., 42 Maiden Lane, N. Y.....	39	Hildreth Mfg. Co., 51 Maiden Lane, N. Y.....	42	Trenton Watch Co., Trenton, N. J.....	18
Sexton Bros. & Ashburn, 41 Maiden Lane, N. Y.....	39	Odenheimer & Zimmern, 46 Maiden Lane, N. Y.....	48	Watch & Clock Dials.	
Engravers and Designers.		Ostby & Barton, 80 Clifford st., Providence, R. I.....	12	Waltham Dial Co., Waltham, Mass.....	19
Bartholomev, & Beckham, 18 Spruce st., N. Y.....	12	Rolled Plate Chains.		Watch & Clock Oils.	
Ryder & D... 146 Westminster st., Providence, R. I.....	12	Barrows, H. F. & Co., 1 1/2 A, Maiden Lane, N. Y.....	27	Ginnel, Henry & Co., 31 Maiden Lane, N. Y.....	11
Eye Glass Holders & Chains.		Kent & Stanley, 7 Eddy st., Providence, R. I.....	3	Nye, William F., New Bedford, Mass.....	44
Merritt, S. F., Springfield, Mass.....	47	Rolled Plate Jewelry.		Watch Keys.	
Fine Jewelry.		Crossin & Tucker, 409 Pine st., Providence, R. I.....	15	Clark, A. N., Plainville, Conn.....	39
Day & Clark, 10 Maiden Lane, N. Y.....	47	Foster & Bailey, 60 Richmond st., Providence, R. I.....	41	Kendrick & Davis, Lebanon, N. H.....	42
Gold and Silver Platers.		Ludwig, H. & Co., Providence, R. I.....	45	Watch Case Manufacturers.	
Newman, Louis, Jr., 36 John st., N. Y.....	9	Plainville Stock Co., Plainville, Mass.....	40	Essex Watch Case Co., Newark, N. J.....	46
Gold Jewelry.		Seal Engravers.		Muhr's Sons, H., 629 Chestnut st., Philadelphia, Pa.....	48
Carter, Sloan & Co., 15 Maiden Lane, N. Y.....	20	Park, Wilham, 26 John st., N. Y.....	47	Roy Watch Case Co., 17 Maiden Lane, N. Y.....	48
Cottle, S. Co., 860 Broadway, N. Y.....	40	Seamless Wire.		Watch Case Repairers.	
Krementz & Co., 182 Broadway N. Y.....	31	Burdon Seamless Filled Wire Co., Providence, R. I.....	40	Feinier, G. F., 9 Bond st., N. Y.....	41
Mo... 11 Maiden Lane, N. Y.....	42	Settings & Galleries.		Watch Importers.	
R... & Co., 860 Broadway, N. Y.....	27	Blancard & Co., 36 John st., N. Y.....	40	Didisheim, Hipp, 83 Nassau st., N. Y.....	9
S... & Westco... Maiden Lane, N. Y.....	19, 27	Silk Guards.		Hydes' Sons, John E., 22 Maiden Lane, N. Y.....	23
...et, Geo. O. & Sons, 15 John st., N. Y.....	11	Silver Plated Ware.		Wittnauer, A., 30 Maiden Lane, N. Y.....	45
Gold Chains.		Sterling Silverware.		Watch Materials, &c.	
Rickert & Stuhle, Newark, N. J.....	38	Durgin, W. B., Concord, N. H.....	13	Cross & Beguelin, 21 Maiden Lane, N. Y.....	19
		Gorham Mfg. Co., 19 st. & Broadway, N. Y.....	7, 24	Friedlander, R. & L., 65 Nassau st., N. Y.....	40
		Towle Mfg. Co., Newburyport, Mass.....	35	Keller, L. H. & Co., 64 Nassau st., N. Y.....	11
		Wallace, R. & Sons, Mfg. Co., 3 Park Place, N. Y.....	6	Watch Repairers.	
		Wood & Hughes, 16 John st., N. Y.....	47	Juzek, Thos. & Co., Elgin, Ill.....	39
		Souvenir Spoons.		Simmonds, J. C., 18 John st., N. Y.....	15
		Dole, H. L., Haverhill, Mass.....	4		
		Gooding Bros., Plymouth, Mass.....	23		
		Hudson, H. G., Amesbury, Mass.....	4		
		Johnston, J. H., & Co., 17 Union Square, N. Y.....	14		
		Low, Daniel, Salem, Mass.....	23		
		Moore & Leding, Washington, D. C.....	31		
		Newhall, W. F., Lynn, Mass.....	8		
		Sterling Silver Souvenir Co., Boston, Mass.....	32		
		Thimbles.			
		Ketcham & McDougall, 198 Broadway, N. Y.....	18		
		Tool Manufacturers and Dealers.			
		American Watch Tool Co., Waltham, Mass.....	33		
		Bullock, O. W. & Co., Springfield, Mass.....	40		
		Nicholson File Co., Providence, R. I.....	29		
		Nordman Bros., San Francisco, Cal.....	18		
		Watch Companies.			
		Non-Magnetic Watch Co., 177 Broadway, N. Y.....	38		
		Trenton Watch Co., Trenton, N. J.....	18		
		Watch & Clock Dials.			
		Waltham Dial Co., Waltham, Mass.....	19		
		Watch & Clock Oils.			
		Ginnel, Henry & Co., 31 Maiden Lane, N. Y.....	11		
		Nye, William F., New Bedford, Mass.....	44		
		Watch Keys.			
		Clark, A. N., Plainville, Conn.....	39		
		Kendrick & Davis, Lebanon, N. H.....	42		
		Watch Case Manufacturers.			
		Essex Watch Case Co., Newark, N. J.....	46		
		Muhr's Sons, H., 629 Chestnut st., Philadelphia, Pa.....	48		
		Roy Watch Case Co., 17 Maiden Lane, N. Y.....	48		
		Watch Case Repairers.			
		Feinier, G. F., 9 Bond st., N. Y.....	41		
		Watch Importers.			
		Didisheim, Hipp, 83 Nassau st., N. Y.....	9		
		Hydes' Sons, John E., 22 Maiden Lane, N. Y.....	23		
		Wittnauer, A., 30 Maiden Lane, N. Y.....	45		
		Watch Materials, &c.			
		Cross & Beguelin, 21 Maiden Lane, N. Y.....	19		
		Friedlander, R. & L., 65 Nassau st., N. Y.....	40		
		Keller, L. H. & Co., 64 Nassau st., N. Y.....	11		
		Watch Repairers.			
		Juzek, Thos. & Co., Elgin, Ill.....	39		
		Simmonds, J. C., 18 John st., N. Y.....	15		

Special Notices.

Rates 75c. per insertion for notices, not exceeding 3 lines; additional words 2 cents each. If answers are to be forwarded, postage stamps must be enclosed. Two insertions, 10 per cent. off; three insertions, 15 per cent. off; four insertions, 25 per cent. off. Payable strictly in advance.

Situations Wanted.

THE JEWELERS' CIRCULAR has a guaranteed circulation of over 10,000 copies weekly. It is, therefore, the best medium for reaching the trade. To demonstrate this to advertisers, notices in this column will be inserted free of charge during the month of April.

A LIVE young man of ability and experience desires position with responsible house to represent them on the road; jewelry or watches preferred; familiar with southern trade; A 1 references. Address, Salesman, care of JEWELERS' CIRCULAR.

A YOUNG MAN, aged 21, who has worked at the watchmaker's bench about two years, wants to finish the trade with a good workman; good reference; good habits. Address, N. R. H., 232 West 5th St., Hutchinson, Kansas.

B Y young married man, as engraver, general workman and salesman; wages moderate; good references. Address, D. F. Lenton, Romeo, Mich.

C OMPETENT book-keeper, disengaged after 3 p. m., would like employment; terms moderate. Address, H. P., care of JEWELERS' CIRCULAR.

P OSITION wanted as salesman in jewelry store; have had 5 years' experience; best of references; New England preferred. Address, H. A. Thrasher, 35 Princeton St., East Boston, Mass.

P OSITION wanted with a first-class house, by practical watchmaker, with 12 years' experience at the bench. Wages expected, \$18 per week; good references. Address, Sober, care of THE JEWELERS' CIRCULAR.

S ITUATION WANTED.—By young man 25 years of age; single; good watch and clock repairer; references. Address, Frank Schaeppi, P. O. Box 44, Norwood, Ohio.

S ITUATION WANTED with first-class watchmaker, as assistant, where I can be instructed in staffing, etc. Address, W. J. Greenawalt, Reading, Pa.

W ANTED.—A situation for a good watchmaker that I can recommend. Address, W. F. A Woodcock, Winona, Minn.

W ANTED.—By a single man of about 30, with nineteen years' experience in the trade, a position as first-class watchmaker and repairer. Is familiar with the use of the lathe. Address, John Scherer, care THE JEWELERS' CIRCULAR.

W ANTED by a young man of 21, a position in a wholesale jewelry, diamond or clock house, as salesman; have 6 years' experience in a retail jewelry store; best of references given. Address, H. C. MacEwen, Jr., 522 Tremont St., Boston, Mass.

W ANTED.—Situation as traveling salesman for a jewelry house, by young man of 21; good habits; best references. Address, Edw. Richter, 606 York St., Newport, Ky.

Help Wanted

A FIRST CLASS watchmaker wanted; wages, \$20 per week. Send photograph and references. Address, P. H. Lachicotte & Co., Columbia, S. C.

W ANTED.—One or two first-class jewelers; must be able to execute the finest grade of pearl, and other stone settings. Address, with reference, Wright Kay & Co., Detroit, Mich.

For Sale.

A FINE ship chronometer for sale cheap. Address: A. C. Taylor, Cedar Rapids, Iowa.

F OR SALE.—A complete "Audemair" trial case; new; price reasonable. Address, The J. Steinmetz Jewelry Co., Helena, Mont.

F OR SALE.—A good paying jewelry business in Milwaukee, Wis.; plenty of bench work; stock and fixtures, about \$2,500 to \$2,700 cash; good reason for selling. Address, Watch, care of THE JEWELERS' CIRCULAR.

F OR SALE.—A Merritt type-writer; nearly new; price \$12. Address, G. A. Gould, Cutchogue, N. Y.

F OR SALE.—On account dissolution of partnership, three iron safes; one fine "Herring Patent Champion"; also fixtures, shop tools, etc. Apply to Moore & Horton, 11 Maiden Lane, New York.

F OR SALE.—One of the best jewelry stores in New England city of 20,000; stock \$4,000. A big chance for man with cash. Address, C. D. N., care of THE JEWELERS' CIRCULAR.

To Let.

T O LET.—First floor back, No. 18 John street, 3 windows; possession at once if desired. Apply to Chas. Magnus.

T O LET.—One office on first floor, one on second floor, and one third floor, of Knapp Building 41 and 43 Maiden Lane, N. Y.

Business Opportunities.

\$2,000 IN CASH and two thousand in notes, will buy old-established and paying jewelry business near New York. Address, Wm. McAdie, with Rogers & Bro., 16 Cortlandt St., N. Y.

\$2,500 SECURES an opportunity of a lifetime, for a jewelry business in the great and growing State of Washington. Address, R., care of THE JEWELERS' CIRCULAR.

T O the benefit of our customers. We have improved our department with expert watch and jewelry repairers. Try us. All work warranted. Address, M. S. Fleishman & Co., wholesale jewelers, 176 & 178 Market St., Chicago, Ill.

Miscellaneous.

W. F. A. WOODCOCK'S SCHOOL FOR WATCH makers, Winona, Minn., offers unrivaled facilities for acquiring a thorough practical knowledge of every branch of the business. Terms very reasonable.

W ORK FOR THE TRADE.—All kinds of watch and jewelry repairing. Skillful workmen, prompt attention and satisfaction guaranteed. Address, A. W. Johanson, 176 & 178 Market St., Chicago, Ill.

Cincinnati.

L. D. Abell, Zanesville, this State, is calling on the trade.

C. Cohen, Huntington, W. Va., is in town to buy diamonds.

Louis Albert has returned from New York and is about again.

A. Herman does not expect to go out until some time in April.

A. Pinover, New York, is here showing some 20-karat diamonds.

G. C. Booth, representing Hutchison & Huestis, Providence, R. I., is here selling some cases of gem rings.

Mr. Bene has returned from a seven weeks' trip. Two weeks ago Mr. Bene received a cablegram from Germany that his father was dead.

Duhme & Co. last week received a very unique wedding invitation from Switzerland, which Mr. Ankeny says calls for a solid silver wedding present.

O. E. Bell has located his jobbing house at 59 W. 4th St. He is very busy putting in the fixtures. He does not expect to be ready for business until April 1st.

Chas. Rauch, of Strauss & Stern, started out on the road on Monday. B. S. Newman, their southern traveler, came home on Saturday. Louis Rau is allowed to stay home with his new wife until April.

Thos. Lovell has re-opened his store at 149 W. 5th St., where he has swung a sign that shows he will wholesale and retail. In a week or so he will have his fixtures up and his goods in his safe, ready for business.

Jeweler Williams has turned his property over to his uncle and fled to Middleport, this State, because one ring from his stock was misappropriated. He put it on the finger of a widow 20 years his senior and flies to avoid adding a wedding ring. At least so the mournful story goes.

The grippe has invaded the jewelers' ranks, and several of the force at D. Schroder & Co. are laid up. Otto Schlitzberger, watchmaker in that establishment, has announced his betrothal to a West End lady.

Jos. Becker was filling orders around town last week for the new Fahys open face Montauk sixteen-size.

NICHOLSON FILE COMPANY,

OFFICES AT

PROVIDENCE, R. I.

WORKS AT

PROVIDENCE AND PAWTUCKET, R. I.

FILES AND RASPS

For Jewelers, Watch Makers, Tool Makers and Every Body Else.

Providence.

Fred. Pratt, 2 Chalkstone St., is out of business.

Everett Spencer is West for Geo. H. Holmes & Co.

Lewis Patstone has discharged a \$2,000 mortgage.

J. W. Benson, Montreal, Que., was in town last week.

E. B. Ingraham is ill with a severe attack of brain fever.

C. A. Russell and wife have gone on a southern trip for pleasure.

Henry Wilson has started in the retail business at 213 N. Main St.

A. V. Payton is putting an addition on his building on N. Main St.

The heirs of the late Charles Downs have advertised their plant for sale.

J. B. Wentworth is now in the employ of Geo. H. Holmes & Co., as foreman.

E. C. Ostby, of Ostby & Barton, who has been on a pleasure trip South, has returned.

C. G. Bloomer & Son contemplate moving their factory further down on the Pawtuxet neck.

The will of the late C. J. Clase will be probated in the Municipal Court on the 24th inst. at 9 A. M.

R. B. Banister, 235 Eddy St., has changed the style of his firm to the Eastern Jewelry Company.

H. S. Dorchester has been nominated by the Republicans as a member of the school committee.

Alfred Vester has the sympathy of a large circle of friends in the loss of his mother, aged 68 years.

S. & B. Lederer have purchased real estate on Pine St., directly in the rear of their present large factory.

J. A. Chamley has been appointed Assistant District Deputy Grand Patriarch of the Patriarch Militant Odd Fellows.

Mrs. Rebecca S. Lovett, wife of Edwin Lovett, died suddenly at her residence last week, in the 74th year of her age.

M. M. Johnson, who was reported several weeks ago as being in danger of losing his eyesight is now rapidly recovering.

Leander Briggs, formerly a bookkeeper for Foster & Bailey, has been indicted by the Grand Jury for promoting a lottery.

William DeWolf, formerly a well-known stone dealer in this city, but now in business in Pittsburgh, Pa., has been in town.

G. A. Hopkins has entered the employ of E. L. Logee & Co., as bookkeeper and will look after the interests of the Boston market.

W. M. Fisher, of W. M. Fisher & Co., Attleboro, Mass., recently met with a painful accident in this city by which one rib was broken.

At the annual meeting of the Providence Corinthian Yacht Club, E. G. Anderson was elected Commodore and J. W. Gammell, Secretary.

The regular quarterly meeting of the Manufacturing Jewelers' Board of Trade will be held at their rooms in the Wilcox building next Saturday afternoon.

Among the District Deputy Grand Chancellors of Knights of Pythias of this State recently appointed are: A. B. Gladding, W. K. Potter and Louis Schmidt.

J. F. Allen, of Allen & Jonasohn, expects to sail on April 11, for Europe on *La Gascoigne*, in search of novelties and new goods. He will return about June 1.

Aibert Eddy, who has been confined to his home with a severe attack of pneumonia, is improving, but has not as yet sufficiently recovered to be able to leave his bed.

The following dealers from out of town were registered in this city during the past week: August Hahn, Henry Dreyfus, Albert Freund and B. Eckstein of New York.

The following jewelers have been appointed as Republican Supervisors of Elections, at the April election: J. W. Martin, W. B. Frost, Louis Schmidt, C. E. Austin and B. L. Hall.

At the Citizen's caucus held in East Providence, Thursday evening, E. F. Seery and C. W. Grube were nominated for Councilmen and E. F. Gottschalk as Moderator for the Third District.

W. B. Menage, formerly a manufacturing jeweler in this city, was recently stricken with paralysis at Needham, Mass, where he has been stopping for some time. There are no hopes of recovery.

News was received in this city last week that Albert Smith, of the firm of Mackinney, Smith & Co., for several years manufacturers of jewelry in this city, died the week previous in Santa Barbara, Cal.

Among the foreign importations into Providence last week were one package of hair chains from Hamburg, one package of imitation stones from Havre and one package from Bremen. The total value of imports was \$24,703.

Royce, Allen & Co. have been making extensive alterations and improvements in their shop in the Lederer Building, which was visited by a destructive conflagration a few weeks ago. The firm will, in a short time, be in readiness to start in the manufacture of novelties instead of dress buttons, which they have decided to abandon.

W. H. Luther & Son, having moved their stock room to their factory on Oxford St., have been making several improvements and alterations and are putting in an extensive plant of the latest apparatus for doing their own plating. This firm was one of the pioneers in the manufacture of campaign badges, and have already got their sample line of badges ready for the campaign of 1892.

Fire escapes have been placed on the Richardson-Hicks buildings at the corner of Friendship and Page Sts. These buildings are largely occupied by manufacturing jewelers, among whom are Robert Barton,

Thornton Bros., Vennebeck & Clase, J. H. Collingwood, Geo. B. Darling, H. N. Pervear, W. R. Richards, Isaac Stone & Co., J. F. Hopkinson & Co., J. W. Cameron and L. W. Pierce & Co.

San Francisco.

H. Marcus, of New York, with Mrs. Marcus is visiting the city. The couple are stopping at the new California Hotel.

W. D. Matthews, jeweler, 106 4th St., who was arrested by Detective Bee and Harper, on a charge of having received stolen jewelry from James Ledger, James Dolan and James Iredel, who are in custody for burglary, has been held for trial in \$400 bonds.

The claim and delivery suit of the American Jewelry Association against Mrs. Herbert Smith to recover a pair earrings or \$94, their alleged value, was tried before a jury in Justice Swasey's court and resulted in a nonsuit. The plaintiffs failed to prove a venue and the value of the earrings, and did not establish the fact of partnership.

The suit for damages of Peter B. Simons & Son against the Elgin Watch Co. will be called for trial in the United States Court in this city this month. The plaintiffs claim that they had arranged with the defendants to do an Australian business in Elgin watches, and that when in the midst of preliminary work another agent was appointed.

Newark.

W. T. Roe, of W. T. Roe & Co., 707 Broad St., is enjoying a vacation in Atlantic City.

B. J. Mayo, while in Birmingham Eng., last year, purchased an old Bible which was printed from wood type during the 15th century. The old piece of literature is in the window of Mr. Mayo's Broad St. store.

Five silver watches, a musical instrument valued at \$76 and \$10 in bills were stolen from the store of Peter Winkler, 143 West St., last Tuesday night. Entrance was effected through the rear windows shortly after the place was closed for the day.

Henry Dresse, an account of whose supposed thefts and ultimate arrest was published in the last issue of THE CIRCULAR, was released from jail, and is re-employed in his former capacity in Hahne & Co.'s store. Young Dresse claimed entire innocence of the thefts and his employers believed him.

Alexander Osborne, 82 years of age, died on Thursday at the almshouse in the city. Some years ago Mr. Osborne conducted a refining and smelting establishment at Bergen Point. Afterward he was offered the superintendency of the Philadelphia mint, which he declined to accept.

Robbed While Attending a Funeral.

WILMINGTON, Del., March 20.—During the absence from home yesterday afternoon of the family of J. H. Ayars, who were attending the funeral of Mr. Ayars' father, Preston Ayers, their house was robbed of jewelry valued at \$1,500.

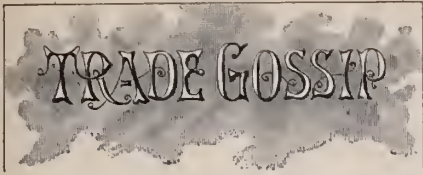

The advertisement of the Webster-Whitcomb lathe, published in another column, should be read by all watchmakers and repairers.

Lapp & Flershem, Chicago, Ill., have issued their March circulars and are offering some very profitable bargains in the shape of gold filled watch cases, plated silverware, and charms and fancy clocks. Jewelers about to purchase these goods should at once write for price-list.

Kremenz & Co., 182 Broadway, New York, have produced a line of gold hair pins that is meeting with unusual success. It comprises a series of designs, which while being both artistic and pleasing to the eye, gratify the prevailing desire for rich and complicated carving. They are shown without and with mountings and will form a profitable line to jewelers.

An anti-tarnish tissue paper for the wrapping of solid or plated silver goods that has been proven thoroughly effective under severe and trying circumstances is that manufactured by the Diamond Paper Mills Co., 44 Murray St., New York. Goods can be kept for months in this covering, and still retain their original brightness and freedom from tarnish. The paper, which by its whiteness and fine finish can readily be recognized from other tissues, is sold at a price considerably less than that paid for imported tissues. To enable the trade to test this paper with other tissues, the Diamond Paper Mills Co. will gladly furnish all the samples required free of charge on mention being made of THE CIRCULAR.

KREMENTZ & Co.,
182 & 184 Broadway, NEW YORK,

MANUFACTURERS OF

GOLD JEWELRY,

14-K. BEAD NECKLACES,

— AND —

KREMENTZ ONE-PIECE COLLAR BUTTONS.

LEON J. GLAENZER & CO.,

80 CHAMBERS STREET

35 Boulevard de Strashurg,
PARIS. JJ

NEW YORK.

OUR SPECIALTIES:

Clocks, Porcelains, Faiences, Bronzes.

We have now on exhibition and are constantly receiving large shipments of the latest novelties in **Onyx and Marble Clocks**, with Gilt and Enamelled Trimmings, **Regulators, Traveling Clocks, Porcelain and Gilt Mounted Clock Sets, Vases, Candelabras, etc.**, which we are offering at **Lowest Prices.**

Our stock also comprises a large assortment of **Porcelains, Faiences, Bronzes, Gilt and Silver Photo Frames, Jewel Boxes, Bonbonnières, Mirrors, etc.**, suitable for the jewelry trade.

SPECIAL INDUCEMENTS ON IMPORT ORDERS.

THE WASHINGTON CITY SOUVENIR SPOON.

THE ONLY NATIONAL SPOON PRODUCED.

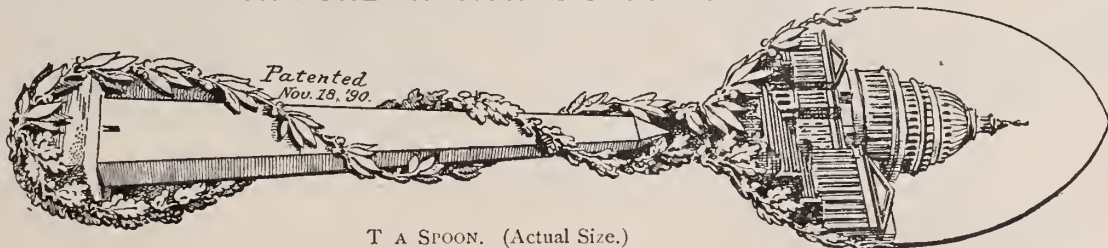

T A SPOON. (Actual Size.)



COFFEE SPOON. (Actual Size.)

PHENOMENAL SUCCESS.

The Best Seller of them all.

MADE IN STERLING SILVER ONLY.

Coffee, Orange and Tea Sizes; also Paper Cutters, Bonbon Spoons, Etc., Etc.

LIBERAL DISCOUNT TO THE TRADE.

SEND FOR DESCRIPTIVE CIRCULARS AND PRICES.

MOORE & LEDING, 1109 Penn. Ave., Washington, D. C.

It has become imperative that even the smallest village must have among its citizens some one who is proficient in fitting glasses. The proportion of people using glasses to the entire community is said to be 1 to 3. Of this large proportion, there is undoubtedly a good number who require no glasses, but use them from a fashionable point of view, or in ignorance. Jewelers if they desire to receive practical and scientific instruction in fitting glasses, should address the Julius King Optical Co.

The Week's Arrivals.

The following dealers from out of town were registered in New York during the current week: H. M. Elias, of Albany, N. Y., Astor H.; D. H. McBride, Cleveland O., Windsor H.; J. L. Taylor, Cleveland, O., Imperial H.; F. E. Davis, Philadelphia, Pa., Astor H.; H. A. McCall, Philadelphia, Pa., Brunswick H.; J. Barron, Shreveport, La., at 22 Howard St.; J. Palmer, Philadelphia, Pa., Metropole H.; L. H. La Due, Minneapolis, Minn., at 258 Church St.; H. W. Pratt, Boston, Mass., Brunswick H.; Chas. F. Weber, Philadelphia, Pa., Continental H.; T. Holbrook, Boston, Mass., Grand Union H.; J. G. Thompson, Boston, Mass., Murray Hill H.; A. S. Foster, Boston, Mass., Hoffman H.; H. Wm. S. Walker, Montreal, Can.; F. L. Houghton, Boston, Mass., Astor H.; E. B. Page, Boston, Mass., Murray Hill H.; J. S. Bennett, Philadelphia, Pa., Astor H.; M. Freudenheim, Elmira, N.

Y., Astor H.; Wm. Watson, Boston, Mass., Astor H.

One of Newark's Oldest Jewelers Expires.

NEWARK, N. J., March 21.—A victim of heart disease and gastric fever, Francis Lebkuecher died on Friday morning at his home at 450 Washington St., this city, at the age of 77. Mr. Lebkuecher leaves a widow and three married children.

Mr. Lebkuecher was born in Kriftel, Rheinhessen, in 1814, and in 1848 came to America. When he retired four years later, he obtained employment in Newark with the old firm of Alling, Hall & Dodd. About 1864 he started in business for himself as a manufacturer of chains in the Hays Building, on Broad St. Under his shrewd management the concern prospered, and in 1872 he consolidated with Krementz & Co., a firm composed of his nephew and son, which had been in existence since 1866.

In 1885 Mr. Lebkuecher retired from active business, and since that date until a short time before his death.

One of the Crescent Co.'s Officers Dies.

BROOKLYN, N. Y., March 18.—Last Friday W. E. Matthews, secretary and vice-president of the Crescent Watch Case Co., left the factory, complaining that he was feeling unwell. He went home and it was found he had contracted a heavy cold. He continued to become worse and last Wednesday evening died.

Mr. Matthews who lived at 474 Henry St., this city and leaves a widow and one child, was until five years ago connected with the large wool house of Garner & Co., New York. He was a member of Company A., Twenty-Third Regiment, the Manufacturers' Club, Philadelphia, and Orange Club, Orange, N. J. He was born in Brooklyn in 1862, and his death is generally regretted in the trade.

Chicago.

The inventory of the estate of "Diamond Joe" Reynolds is about completed, and shows the estate to reach almost \$10,000,000.

Jennie H. Sent has brought suit against her husband, jeweler George Sent, to restrain him from disposing of his property. The petition was granted.

Reed, Barton & Co., Taunton, Mass., have decided to open a branch office in this city at 155 State St. The office will be under the charge of J. Drukker.

The Chicago Watch Installment Co. have been incorporated; capital stock, \$5,000; incorporators, George W. Herron, George Kendall and Richard A. Errion.

State-Attorney Longenecker is confident that the man under arrest in Anderson, S. Dak., is really Tascott, the murderer of millionaire Snell. A portrait of him has been identified as that of Tascott by a jeweler in this city, A. G. Clarke, 481 W. Madison St., who knew Tascott.

BOSTON, MASS., March 19, 1891.

DEAR SIR:—The growing craze for Souvenir Spoons has brought such a demand for them that we have introduced three spoons of National character, viz: the WASHINGTON, the LINCOLN and the GRANT Spoons.

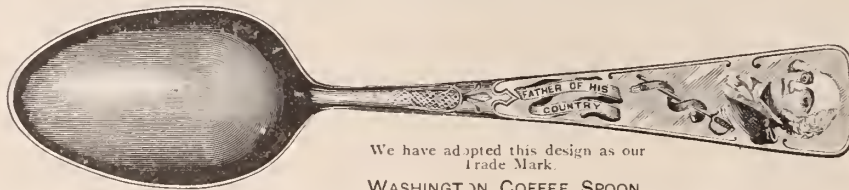

We have adopted this design as our Trade Mark.

WASHINGTON COFFEE SPOON.

We have spared no pains to make them a work of art, and they are of the highest class of workmanship in design and finish.



We have adopted this design as our Trade Mark.

LINCOLN TEA SPOON.

In the short time that they have been on the market there has been a large and growing demand for them. We believe the craze for collecting Souvenir Spoons is still in its infancy, and that there will be a fast growing demand, and that dealers will find ready market for them.



We have adopted this design as our Trade Mark.

GRANT ORANGE SPOON.

Our designs, representing such well-known National characters, will need no advertising or recommending to sell them.

P. O. DRAWER NO. 5324.

Very truly yours,

Sterling Silver Souvenir Co.

SEND FOR ILLUSTRATED CIRCULAR AND PRICE LIST.

Recent Patents

Issue of March 17, 1891.

DESIGN No. 20,584. SPOON OR FORK. ERNST SCHALL, Hartford, Conn.—Application filed January, 27, 1891. Serial No. 379,327. Term of patent 3½ years.

DESIGN No. 20,586. MATCH-SAFE. EGERTON A. BLISS, New York, N. Y., assignor to THE E. A. BLISS COMPANY, same place.—Application filed January, 28, 1891. Serial No. 379,453. Term of patent 7 years.

DESIGN No. 20,587. LACE-PIN. ALBERT EPPLE, Providence, R. I.—Application filed October 1, 1890. Serial No. 366,763. Term of patent 3½ years.

DESIGN No. 20,590. THIMBLE. HENRY A. WEINMAN, Philadelphia, Pa.—Application filed February 6, 1891. Serial No. 380,505. Term of patent 14 years.

448,325. ELECTRIC ALARM CLOCK. EDWARD M. EDGERTON, Chicago, Ill.—Filed Nov. 21, 1889. Serial No. 331,108. (No model.)

448,510. ILLUMINATED CLOCK. AUSTIN A. DUBOIS, Brooklyn, N. Y., assignor to Morris Hart, same place.—Filed Sept. 20, 1890. Serial No. 365,624. (No model.)

The combination, with a clock having the hour-hand tube extending from the face thereof, of a dial mounted on the hour-hand tube, a lamp adapted to rest upon the dial and having in its bottom a socket for the hour-band tube, a globe for the lamp, this globe having the

hours of the day inscribed thereon, and a hand hinged to the clock-case so as to be turned opposite the globe when the lamp is in position and to extend across the dial of the clock when the lamp is removed.

448,549. STOP-WATCH. CHARLES SCHLATTER, Hoboken, N. J.—Filed March 24, 1890. Serial No. 345,028. (No model.)

The combination, with the pinions having stationary arbors and arranged in different vertical and horizontal planes, of a rocking frame arranged between

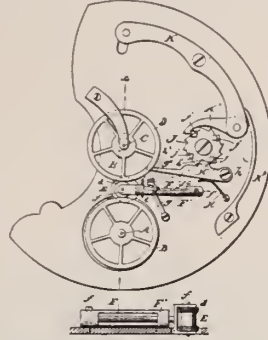

the pinions and carrying pinions, this frame being movable to disengage the second-named pinions from both the first-named ones.

448,560. TIME-RECORDER. FRANCIS E. TYNG, Irvington, N. Y.—Filed May 8, 1890. Serial No. 350,995. (No model.)

448,594. METHOD OF MAKING PLATED WIRE. CHARLES R. SMITH, Providence, R. I., assignor to the C. R. Smith Plating Company of Kentucky.—Filed Dec. 24, 1890. Serial No. 375,711. (No model.)

The improved process of making plated wire consisting in depositing upon a metallic rod by electroplating a thin layer or film of another metal, then placing upon the electro-plated rod a metallic shell or

tube, then subjecting the whole to heat sufficient to fuse the electro-deposited metal, thereby soldering the shell or tube to the rod, and then reducing the same to wire by any of the usual methods for that purpose.

448,610. FINGER-RING. CHARLES GOSLING, Brooklyn, assignor to Stern Brothers & Co., New York, N. Y.—Filed Jan. 1891. Serial No. 376,945. (No model.)

The combination, with the finger-ring having a box, a transverse keeper in this box, and a slot at right angles to the keeper, of a stone having a recess at the under side for the keeper, a longitudinal guide-recess



at right angles to the recess, and a latch guided in the recess and provided with a pin which projects by its upper end into a shorter recess of the stone, while its lower end is guided in the slot of the box.

448,617. BRACELET. THOMAS C HUDSON, Providence, R. I., assignor to George L. Vose, same place.—Filed May 22, 1888. Serial No. 274,722. (No model.)

A bracelet consisting of a resilient hoop, having a stop or enlargement at one or both ends and an ornamental box or center provided with a concealed groove,

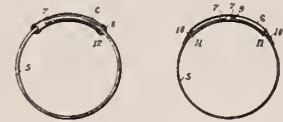

and a slit at one or both ends smaller in area than the groove, constructed to receive the end or ends of the hoop and permit of the enlargement of the hoop and its automatic contraction.

"WE CONSIDER"

OUR WEBSTER-WHITCOMB Lathe, in fact, we KNOW it is

THE

BEST LATHE MADE.

SO DO THE FOLLOWING PARTIES WHO HAVE THEM:

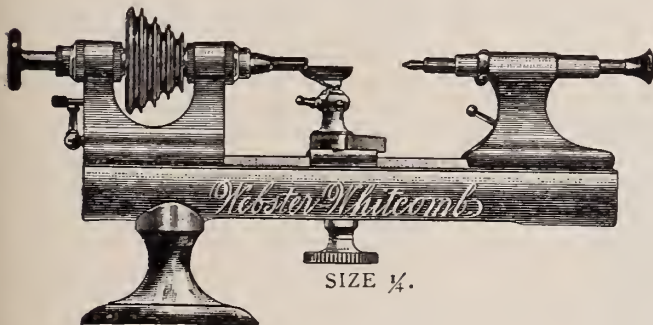

- W. H. MAIRE, of Princeton, Ky., writes: "The lathe is just at hand, and I assure you it is just what I want. It is as near perfection as they get, I think."
- S. T. RUSSELL, of West Plains, Mo., writes: "The lathe is a dandy in every respect. It gives perfect satisfaction in every respect."
- OSCAR J. FUCHS, of Chillicothe, O., writes: "My Webster-Whitcomb lathe is giving me No. 1 satisfaction, and I expect I will have to buy some more attachments soon."
- GEO. E. TEW, of Seattle, Wash., writes: "My lathe is perfectly satisfactory, and I consider it the best lathe made."
- C. A. BECK, of Franklin, Ind., writes: "I think more of my lathe than I do of myself."
- TAINTOR & McALPINE, of Easthampton, Mass., writes: "We have one of your fine Watchmakers' lathes with full set of chucks, universal head, slide rest, filing attachment, etc., and find them perfect tools."

With every lathe we send the following guarantee:—

"This certifies that the lathe marked 'American Watch Tool Co., No. —' was made by us from the best materials, on the most approved plan, and is a reliable lathe. For any defect in material or workmanship we hold ourselves responsible. Notify us promptly of any faults.

"Waltham, _____

By _____"

This guarantee is also signed by the inspector who has the final inspection of the work. For several years past we have tied upon every lathe a tag of caution and instruction. All purchasers are requested to demand these documents with the lathes they buy. Remember our address:

AMERICAN WATCH TOOL CO.,

STONY BATTER WORKS

WALTHAM, MASS.



Easy Lessons for Opticians.

BY C. A. BUCKLIN, A. M., M. D.

In our last article we gave a brief but somewhat comprehensive description of the many classified peculiarities of vision which cause people who cannot be benefited by lenses to apply to opticians for relief. We now pass to one of the most intensely practical mechanical questions involved in the binocular visual act. This subject is the consideration of the physiological action of the ocular muscles and the annoyances which result from any impairment of their natural strength.

Each eye is provided with six muscles which act in such perfect unison that without any sense of fatigue both eyes are directed at required objects in such a way that the visual images always fall on exactly corresponding points of the two retinas.

We have the straight or recti muscles. These are four in number and they move the eye in a straight line toward the muscle which is contracting. These muscles are all attached to the globe not far from the margin of the cornea, and consequently direct the visual line toward the contracting muscle. We next have the oblique muscles which are two in number. They are attached to the outside of the globe and also to the backside; consequently when contracting they direct the visual axis in an opposite direction from the contracting muscle.

The ocular muscles of the eye have the following names and perform the following functions: The internal rectus muscle is the only one which produces motion inwardly. It has fully double the power of any other muscle or set of muscles attached to the eye. It is the muscle most directly concerned in producing comfortable convergence for binocular vision. We next have the superior rectus which is a very weak muscle and turns the eye directly up. This muscle, combined with the inferior rectus, which is also a very weak muscle and turns the eye directly down, has the task to perform of maintaining an equal elevation or depression of the visual axes of the two eyes. As these requirements are met with very small amounts of muscular exertion, these two muscles are for obvious reasons of much less strength than any of the other recti muscles. The oblique muscles have a somewhat complex action. The superior oblique starts at the apex of the orbit and runs forward to upper and inner quadrant of the orbit, then passes backward and outward, becoming attached to the posterior and outward quadrant of the globe. This muscle when contracting alone, rotates the eye down and out. Thus, it assists the

inferior rectus in turning the eyeball down and the external rectus in turning the eyeball out. The inferior oblique muscle has its origin at the lower edge of the orbit. It passes back and out under the globe, becoming fastened to the posterior and outer quadrant of the globe. It assists the superior rectus in turning the eye up and the exterior rectus in turning the eye out. The two oblique muscles encircle the globe like a sling; when they contract together equally, they turn the eye directly out.

From a careful consideration of the above description, the complicated actions of the oblique muscles will be understood. It is probable that the most important functions of these muscles are to retain corresponding meridians of the globe in corresponding positions as the head is inclined from side to side.

As the result of disease, any one of the ocular muscles may be partially paralyzed. This accident leads to any of the three following consequences: First, grotesque positions of the head; Second, diplopia; Third, muscular asthenopia. When a muscle is slightly paralyzed the head may be turned in such a position that the muscle is partially or completely thrown out of use. Then the fellow eye, having healthy ocular muscles, will do the work which was formerly done by both muscles. The unaffected eye under these circumstances directs its visual axis to the point where the visual axis of the paralyzed eye is directed. An individual will resort to a grotesque position of the head when by so doing he can successfully overcome the tendencies to diplopia. If unable to overcome the difficulty by placing the head in such a position that the weakened muscle is greatly favored the person will either have diplopia or muscular asthenopia.

Diplopia develops when the paresis is extreme or when corresponding muscles of both eyes are affected.

Muscular asthenopia is the fatigue resulting from successful but excessive efforts to maintain binocular vision. It may be because the individual has not discovered how to assume the proper grotesque position of the head to favor the weak ocular muscle. Again the advantages gained by changing the head so as to favor a weak muscle are not of sufficient benefit to prompt the individual to resort to this artifice for the purpose of relieving his weak ocular muscle. In another class of cases the ocular muscles of both eyes are so weakened that the additional task required of the fellow eye when the head is so placed as to favor a given muscle of the affected eye, cannot be performed.

In these cases, during binocular fixation, it is evident that every degree of favor extended to a weakened muscle of one eye, must be fully compensated for by additional work of the corresponding muscle of the fellow eye. When neither by a muscular effort nor any favoring position of the head the defective action of the muscle can be compensated for, the various forms of diplopia or double vision appear.

Diplopia.—As a result of education we learn to judge of the relative position of objects by the position the retinal image occupies on the retina. In the right eye any object appears to be to the left when the retinal image falls on the temporal side of the line of fixation and the objects in this eye appear to the right when the visual line falls on the retina to the nasal side of the line of fixation. Should one eye from a paralysis of the internal rectus, bring the image from an object situated in the line of fixation of the fellow eye to fall on the portion of the retina upon which objects to the extreme left had formerly cast images, double vision would result.

To the unaffected eye the observed object would be in its natural position. That position of the retina of the affected eye upon which objects to the extreme left formerly fell by the turning of the globe, is now exposed to the line of vision; consequently double vision is produced, and the image seen with the right eye appears to be situated to the extreme left. This condition is called *crossed diplopia*, and when existing is a positive proof that one or both of the internal recti muscles have been paralyzed.

When one eye deviates inwardly as a result of paralysis of an external rectus muscle, the false object will appear widely displaced toward the muscle affected. The external rectus muscle of the right eye being paralyzed, the object seen with the right eye will be located to the extreme right. The defect is, under these circumstances, called *homonymous diplopia*. A lighted candle, at twenty feet, is the usual test used in experimenting for diplopia. By placing a red glass before the right eye, the light seen with this eye becomes red; consequently, from the position of the red light, as compared with the white one, we may conclude at a glance, in diplopia, which is the faulty muscle or muscles.

Slight vertical diplopias are very frequent; they cause most distressing asthenopic symptoms. In this defect one light is seen slightly above the other. Prisms produce more gratifying results when used for the correction of vertical diplopia than for any other form of this defect.

Diplopias, as a result of paralysis of the superior oblique muscles, are quite frequent. When affecting the right eye, the extra light is lower laterally displaced to the right, and has a decided slant. Paralysis of the inferior oblique is not so frequently seen because other muscles are always involved. Diplopias from paralysis of the oblique muscles are very difficult to correct in a satisfactory manner.

In superior oblique paresis the tendency of the eye to go up is overcome by dealing with the superior rectus muscle. The various forms of tests and the treatment for diplopia and muscular asthenopia will be taken up in our next.

EFFECTS OF ELECTRIC LIGHT ON SIGHT.

DETROIT, Mich., March 6, 1891.

To the Editor of The Jewelers' Circular:

Can you give us any information regarding what ill effect the electric light has upon the human eye? We

have heard considerable controversy on this subject and we should like to know what your observations have been as regards both the arc and incandescent. We are under the impression that they are very injurious to the eye even for a short interval, say an hour or two at night, and that it is almost impossible for working men to work under them all day, day in and day out. Any information you can furnish us on the subject will be thankfully received by,

Yours respectfully
A. BACKUS, JR., & SONS.

ANSWER:—They prove very annoying to some eyes. No well authenticated cases are on record where they have produced any permanent or serious injury to the eyes. The annoyance must be similar to snow blindness but on a much smaller scale. I think that the press have greatly exaggerated the damages to the eyes which are possible from electric lights.

USE OF THE CANAL SCHLEMM.

SPARTA, Ga., March 4, 1891.

To the Editor of the *Jewelers' Circular*:

I would like you to get Dr. Bucklin to answer in your *Circular* the reason for and the use of the "Canal of Schlemm;" does it contain any fluid, and if so, what, and also the reason and use of the Zone of Zim.

J. G. BABCOCK.

Answer:—Canal of Schelemm is a lymphatic vessel; probably the lymphatic vessel of the cornea. It performs the ordinary functions of a lymphatic. The Zonula of Zim is the suspensory ligament of the lens. Its functions are fully described by Helmholtz, and it will be found under accommodation in every text book.

To Temper Steel.

WE know, says the *Journal Suisse d'horlogerie*, that tempered steel loses little by little (in proportion to the degree to which it is re-heated) the properties the temper had given it. Up to about 215°, the effects of the annealing are hardly perceptible, but between 215° and 325° they become very marked and allow of the required quality being given to the steel.

The essential point for always obtaining the same effects is to heat to a determined temperature. The colors which the metal takes as it is heated aid us in this determination, but we may also readily ascertain the temperature directly in a bath or stove by means of a suitable instrument. As mercury boils at 357°, a thermometer constructed with this liquid can be easily read up to about 330°.

For these high temperatures, thermometers are made in which a small quantity of nitrogen is introduced above the mercury. This prevents the rupture of the mercurial column and regulates the readings. It is only necessary to take into account the fact that the glass of thermometers exposed to rather extensive variations of temperatures itself varies; the capacity of the reservoir changes, and results in a lowering of the zero. The readings given by the thermometer are then too small; but it is easy to determine the correction by plunging the instrument into melted ice, and noting the degree marked; the figure of the degree shows the correction to add to the indica-

TOWLE MFG. CO.,

MANUFACTURERS OF



Sterling Silverware



NEWBURYPORT, MASS.: 214 MERRIMACK ST.

CHICAGO:
149 & 151 STATE ST.

SAN FRANCISCO:
220 SUTTER ST.

ESTABLISHED 1873.



If for any reason you should desire the services of an AUCTIONEER, and will write me as to the amount of stock you have on hand and its general character, the size of your store and the number of inhabitants of your town or city, I could, from my extended experience, give you an idea of the amount of business you could expect under the circumstances, and, no doubt, be able to refer you to some one for whom I have sold under conditions similar to your own.

As a general reference, you could hardly find a wholesale jeweler who is not familiar with some of the numerous successful sales I have made.

I have made many successful AUCTION SALES, and have yet to record a failure to fully satisfy the owners. Can give you hundreds of references to that effect.

If the business should be urgent and I am myself engaged, I have two competent assistants instructed in my methods whom I could send on short notice.

Any correspondence with me will be strictly confidential in every case.
P. O. Box 2775.

NEW YORK CITY.

ONE OF THE OLDEST RESTAURANTS
DOWN TOWN.



POPULAR PRICES.

B EING convinced that after a fair trial you will find it to your advantage to take

The Jewelers' Circular

regularly, we offer the following inducements to new subscribers:

UPON RECEIPT OF TWO DOLLARS

(the price of one year's subscription), we will send THE CIRCULAR for one year (52 numbers) to any address, and a copy of our book of **Monogram Plates**, which contains **44 Plates** or **2,112 Monograms** in all, in six different styles. Or, for

50 CENTS, WE WILL SEND

The Jewelers' Circular

For **SIX MONTHS** on trial.

Either of the blanks given below, if filled out and returned with the proper amount of money, will secure for you one of the best trade journals in the world for the time stated.

189

TO THE Jewelers' Circular Publishing Co.,

189 BROADWAY, NEW YORK.

Enclosed please find TWO DOLLARS, for which send THE JEWELERS' CIRCULAR for One Year, beginning _____ and one book of Monogram Plates.

NAME, _____

ADDRESS, _____

189

TO THE Jewelers' Circular Publishing Co.,

189 BROADWAY, NEW YORK.

Enclosed find FIFTY CENTS, for which send THE JEWELERS' CIRCULAR for SIX MONTHS, on Trial, beginning _____

NAME, _____

ADDRESS, _____

PREMIUM LIST.

TO THE RETAIL TRADE:

We want 10,000 new subscribers added to our subscription list, and in order to get them we make some remarkable inducements for a LIMITED TIME ONLY.

SEND US TWO DOLLARS,

the regular subscription price of THE CIRCULAR, and we will send you any of the combinations described below, and

THE JEWELERS' CIRCULAR FOR ONE YEAR.

The articles in any of these combinations if purchased separately would cost from \$2.00 to \$3.00. They have been carefully arranged by an expert watchmaker as being such as are called for in every days' experience. They are first-class goods, will be carefully selected, and sent promptly.

In ordering, be particular to do so by the letter as arranged.

COMBINATION A.

Two dozen American Cock and Foot Jewels, assorted as follows:

1/4 doz.	Waltham,	18s.	O. M.,	Cock.
1/4 "	"	18s.	"	Foot.
1/4 "	"	18s.	N. M.,	Cock.
1/4 "	"	18s.	"	Foot.
1/4 "	Elgin,	18s.		Cock.
1/4 "	"	18s.		Foot.
1/4 "	Illinois,	18s.		C.&F.
1/4 "	Hampden,	18s.		C.&F.

COMBINATION B.

Two dozen American Cock and Foot Jewels.

1/3 doz.	assorted Waltham,	18s.	C. & F.
1/3 "	"	Elgin,	18s.
1/6 "	"	Illinois,	18s.
1/6 "	"	Hampden,	18s.
1/6 "	"	Rockford,	18s.
1/6 "	"	Columbus,	18s.
1/6 "	"	Peoria,	18s.
1/6 "	"	Seth Thomas,	18s.
1/6 "	"	Trenton,	18s.
1/6 "	"	Lancaster,	18s.

COMBINATION C.

Two dozen American Endstones, assorted.
Same as Combination A.

COMBINATION E.

Two dozen American Balance Staffs assorted as follows:

1/3 doz.	Waltham,	18s.	assorted styles.
1/3 "	Elgin,	18s.	grades.
1/3 "	Illinois,	18s.	"
1/3 "	Rockford,	18s.	"
1/3 "	Hampden,	18s.	"
1/6 "	Columbus,	18s.	"
1/6 "	Seth Thomas,	18s.	"

COMBINATION D.

Two dozen American Endstones, assorted.
Same as Combination B.

COMBINATION F.

Eight dozen American Roller Jewels assorted as follows:

1 doz.	Waltham,	18s.
1 "	"	8s.
1 "	Elgin,	18s.
1 "	"	6 & 8s.
1 "	Rockford,	18s.
1 "	Illinois,	18s.
1 "	"	4s.
1 "	Hampden,	18s.

COMBINATION G.

Two dozen American Winding and Interwinding Wheels, assorted as follows:

1/3 doz.	Waltham,	18s.
1/6 "	"	8s.
1/3 "	Elgin,	18s.
1/6 "	"	6 & 8s.
1/3 "	Rockford,	18s.
1/3 "	Hampden,	18s.
1/3 "	Illinois,	18s.

COMBINATION H.

Two dozen assorted Yoke, Clutch and Click springs for Swiss Watches, the most desirable patterns and only those for which there is a constant demand.

COMBINATION K.

Six dozen assorted American Collected Hair Springs assorted as follows:

1 doz.	Waltham,	18s.
1 "	"	8s.
1 "	"	1s.
1 "	Elgin,	18s.
1 "	"	16s.
1 "	"	6 & 8s.

Four dozen assorted Yoke, Clutch and Click springs for American Watches. Only such will be sent for which you will find steady demand.

COMBINATION I.

COMBINATION L.

One gross American Hands assorted as follows.

1 doz	18s. Spade, K. W.
1 "	18s. " S. W.
1 "	8s. " S. W.
1 "	8s. Morning Glory, S. W.
1 "	1s. Spade, S. W.
1 "	18s. Moon, K. W.
1 "	18s. " S. W.
1 "	18s. Morning Glory, K. W.
1 "	18s. " S. W.
1 "	18s. Seconds.
1 "	8s. "
1 "	1s. "

COMBINATION M.

Two dozen *Harstroms* Pat. Casesprings, assorted sizes (considered to be the best and most easily fitted spring in the market).

COMBINATION O.

Jewelry Findings assorted as follows:

1 doz.	Plated Clipped Catches.
1 "	" Joints.
1 "	Roll Plated Ear Wires.
3 "	Burnished Pintongs.
1/3 "	R. P. Lever Button Backs.
1/2 "	" " Spiral Stud
1/3 "	" " Scarfpin
1 "	" " Jump Rings assorted sizes.
1 "	Bracelet and Necklace Snap Catches.

COMBINATION N.

Five dozen assorted Clark's (4 screw) steel lift and catch case springs suitable for Swiss and American cases.

COMBINATION P.

Two dozen fine American Mainsprings, assorted sizes, for Waltham and Elgin Watches.

tions of the thermometer. It is well to repeat this test from time to time, the displacing of the zero point being often very slow. It sometimes remains displaced for a long time.

From the practical point of view, it is unnecessary to know exactly the temperature other than that to which we are working, provided that the same can always be certainly reproduced; and this is easy to manage with a thermometer of any kind, by making preliminary experiments upon objects of the same nature as those we wish to temper. For testing the objects, we may employ a hot air stove, or better still (especially if it is large enough), a liquid bath in which can be plunged an iron receptacle capable of being closed, containing the objects to be tempered. The thermometer is not plunged in the bath, but in an iron tube immersed in the liquid; this facilitates getting it out and lessens the chance of breaking it. With regard to the liquid, the best is a mixture of lead and tin; the more tin it contains the more it is fusible.

Oil is not suitable, on account of the bad odor it gives off at high temperatures; but paraffine may be used, which has not this inconvenience. If a bath of somewhat large capacity is employed it is comparatively easy to maintain its temperature. The objects are thus submitted to the same heat and tempered uniformly. The temperature not varying, they may also be left a longer or shorter time in the bath.

In the above remarks, gas is understood as the heating agent; if that cannot be used, petroleum furnaces are recommended for the purpose, provided other conditions allow of an easy and prompt regulation of the temperature. In the case of an air stove, where there are many more variations to fear, it would be well to have an automatic regulator of the temperature. There exist many models of such for the use of chemists.

Pivoting a Cylinder.

IN pivoting, a cylinder is seldom drilled. The upper and lower pivots are the extremities of a plug closely fitted in each end. In most cases the top pivots may be replaced by resting the cylinder on a stake, the hole of which is of sufficient diameter to allow of the entrance of the plug and too small to allow the cylinder to pass through. A knee punch is used and a few slight taps of the hammer will be sufficient to drive the plug out the required distance for turning on a new pivot. The lower end, however, is generally so short as to require an entire new plug, as its short length will not admit of its being brought out a sufficient distance. In this case the plug should be driven out entirely and a new one, which has the pivot roughed out on it, inserted. Should there be any difficulty in driving out the plug on account of its being too tight, a few light taps all around the cylinder will generally be sufficient to stretch the cylinder.

Repairing Lower Center Pivot.

WHEN repairing a watch, the repairer finds, let us say for the sake of a subject, that a new center wheel lower hole is required, and, as is often the case, the pivot is cut, the pivot should be first repaired; and if the great wheel and third wheel depths have been originally correct, the best plan will be to push out the old bushing in the plate, drill a hole in a piece of brass nearly as large as the pivot, and turn the bushing to fit the hole—this being the way most finishers bush this hole; it will leave the depths as they were originally, and is much easier riveted than a solid bushing.

When the hole is broached to fit the pivot and the rivet of the bushing is turned down, if a new hole is required in the top plate, the upright should be got as follows (by what is called "pegging the hole"): Place the mandrel in the center hole and grip the plate with the dogs near to the outside edge of the plate, so that they may not be in the way of the top plate when it is put into its place; bring the rest of the mandrel within about an inch of the plate; cut a point on a long peg and insert the point in the center hole, allowing the peg to lie on the rest; turn the mandrel round slowly, and if the outer end of the peg moves up and down, the frame must be tipped gently on the edge until the motion of the peg is scarcely perceptible; screw up the dogs, and, if a bushing has been riveted in the top plate, the plate can be screwed into its place, and the hole drilled and broached in the mandrel to very nearly the size of the pivot.

WE DESIRE to call your attention to our large and varied assortment of

Complicated, High Grade Gentlemen's and Ladies'



In Gold Cases, both Plain and Enameled, in Choice Designs.

THE LARGEST STOCK EVER SHOWN IN THIS COUNTRY.

NON-MAGNETIC WATCH CO.

OF AMERICA.

CHAS. McCULLOH, RECEIVER

177 Broadway. - - NEW YORK.

AIKIN, LAMBERT & Co.,

23 Maiden Lane,

NEW YORK,

Manufacturers and Exporters of

Fine Gold Pens, Pencils,

TOOTH PICKS, HOLDERS,

And Novelties in Silver, Pearl, &c.



THE BEST FOUNTAIN PENS.

New Assortments in SHOW CASES and FANCY TRAYS for JEWELERS. Price Lists and Catalogues for intending Purchasers.



Also American and Swiss Watches.

DIAMONDS, Loose and Mounted,

Gold and Silver Thimbles,

CHAINS and JEWELRY in New and Staple Patterns.

A. RICKERT.

C.A. STIEHLE.

RICKERT & STIEHLE,

MANUFACTURERS OF

GOLD CHAINS,

SWIVELS AND SPRING RINGS.

Chain Repairing a Specialty.

13 & 15 Franklin Street, NEWARK, N. J.



WHAT CONSTITUTES FIDUCIARY RELATIONS.

Where a wholesale firm delivers goods to a retailer under a contract by the terms of which the retailer is to hold what remains unsold, and the proceeds of what is sold in trust for the payment of his debt, that creates a fiduciary relation, and for failure to account and turn over funds under such a contract, the debtor may be subject to civil arrest.

CARE OF PROPERTY IN TRANSIT.

A complaint in an action against a common carrier to whom property had been delivered for transportation, alleged negligence in the care of the property while in transit, and also after it had arrived at its destination, and remained in the custody of the carrier as warehousemen. This constituted only one cause of action. Evidence of general custom, or of the amount of care exercised by men in general in similar circumstances, is competent upon the question whether a person exercised ordinary care in the custody of a bailment. A witness having special knowledge on the subject, derived from experience in the business, may give his opinion whether a particular course pursued with reference to a special class of freight was proper or not.

LIEN OF BROKER FOR ADVANCES.

Where the broker of a manufacturing corporation has advanced to his principal more cash than the value of the goods consigned to him, he has such a lien on the goods as will justify a transfer of the goods to him by the company just prior to their failure. And a statute which prohibits any transfer of property by the corporation in contemplation of insolvency will not affect such a transfer, for it merely is a recognition of an antecedent lien which was valued as against creditors, and therefore creditors could not be prejudiced by the transfer.

EXTENT OF WARRANTY OF GOODS BY AGENT.

An agent who sells goods may warrant the goods he himself sells, but that warranty does not extend to subsequent independent sales of the same kind of goods by his principal. A sale of oil to be used in the manufacture of carpets, guaranteed to be fit for the purpose, was subject only to guaranty for that sale, but as to the oil which was warranted, and was not up to standard, the rule of damages, if the manufacturers sold their carpets after they became aware of the vicious quality of the oil, and such sales were made under circumstances that left no liability on their part to the purchasers would be the difference between the price actually received and the value of the carpets as they would have been if the oil had been as warranted.

Copyright, 1890, Law News Bureau.

DIAMONDS.

Wm. S. Hedges & Co.,
Importers of Diamonds,

And Manufacturers of DIAMOND JEWELRY.
No. 170 BROADWAY,
S. E. Cor. Maiden Lane, } New York.
27 Holborn Viaduct, London.

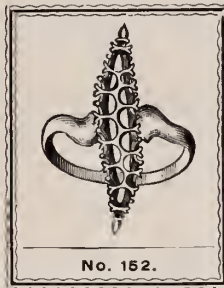

“ S ”

A “NOVELTY” in Marquis Rings.

ASK YOUR JOBBER FOR

STERN BROTHERS' DIAMOND MOUNTINGS,

42 MAIDEN LANE, N. Y.

MAXHEIMER & BERESFORD,

MANUFACTURERS OF

FINE DIAMOND JEWELRY,

No. 3 Maiden Lane, New York.

ORDER WORK A SPECIALTY.

TO THE TRADE ONLY.

Balance Staffs, - 60 Cents.

Inserting Pivots, 40 Cents.

ALL OTHER WORK IN PROPORTION.

SEND FOR PRICE LIST.

THOMAS JUZEK & CO.,
ELGIN, ILL.

R. A. Kipling

Importer of Precious Stones

31, Union Square
New-York

19, Rue Drouot
Paris

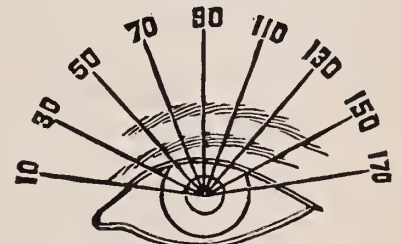

SEND TO

GENEVA OPTICAL CO.

23 Washington St., Chicago.

FOR PRESCRIPTIONS, REPAIR AND ORDER WORK
PROMPTLY AT LOWEST PRICES.

SEXTON BROS. & WASHBURN,

41 MAIDEN LANE, NEW YORK,

MANUFACTURERS OF

FINE JEWELRY,

INCLUDING A FULL LINE OF MOUNTINGS.



PROMPT AND CAREFUL ATTENTION GIVEN TO SPECIAL ORDER WORK.

A. N. CLARK, PLAINVILLE, } MANUFACTURER of the Celebrated
CONN. }

LOOP WATCH KEY:

The best for the price in the World. Size
of Square stamped on each Key.

Also Key Rings, Watch Case Springs,
Jewelry Tools, Tweezers, Etc.



SEND FOR PRICE
LIST.

SOLD BY ALL JOBBERS IN THE LINE
AT MANUFACTURER'S PRICES.

BURDON'S · SEAMLESS.

THE ORIGINAL
And only Genuine



AND
Perfect Seamless Filled Wires
IN THE WORLD.
Sold to all Manufacturers
alike.

Burdon Seamless Wire.
TRADE-MARK.

The success of the BURDON SEAMLESS FILLED WIRE, like that of all important inventions, has been followed by deceptive and imperfect imitations. For the protection of

ALL JOBBERS AND RETAILERS,

we authorize manufacturers who so desire, to affix upon the tag, card or label accompanying the articles made from this wire, this registered trade-mark owned by this Company.

The bird-on-wire is a guarantee that the goods are made from the original Burdon Seamless Filled Wire, the reputation of which has been firmly established among the best dealers for more than two years. The perfection and qualities of the Burdon Seamless Wires are always guaranteed. All Dealers (jobbers and retailers alike) should, therefore, demand goods made from the original Burdon Wire, and avoid imitations which are offered as "just as good."

BURDON SEAMLESS FILLED WIRE CO.,
109 to 119 and 127 Summer Street,
PROVIDENCE, R. I.

TELL A. BEGUELIN,
IMPORTER OF
WATCHES,

Watch Materials, Tools and Glasses,

No. 71 NASSAU STREET,
(UP STAIRS.)

Cor. John Street, NEW YORK.

Sole Importer of Material for the

"Bijou," "Victor," "Boston," "Bristol,"
"Adelphia," "Jockey Club," "Wallingford,"
"Cæsar," "Lady Racine" and "New Haven"
Watches.

AMERICAN WATCHES.
ALSO STEM WIND WHEELS.

Full Line of SWISS WATCHES,

ALSO IMPORTER OF
FRENCH CLOCK GLASSES.

S. COTTLE & CO.,
MAKERS OF

FINE JEWELRY AND SILVER
NOVELTIES,

No. 86o Broadway, NEW YORK.

ARTIFICIAL EYES!



STOCK ORDERS of
Selection Packages.

Largest Assortment.

GENEVA OPTICAL CO.,
23 Washington St., Chicago.

R. & L. FRIEDLANDER,

Wholesale Jewelers,

AND

JOBBERS IN AMERICAN WATCHES,

Tools, Materials and Optical Goods,

65 & 67 NASSAU STREET, N. Y.

Factory, 50 BOND STREET.

Send Business Card and we will mail you our Watch and Jewelry Catalogue-
No. 12, and our Tool, Material and Optical Catalogue, No. 14.

READ THIS LETTER:

HENRY ERBSMEHL,

Watchmaker & Jeweler,

Watches, Clocks, Jewelry and Silverware.

MESSRS. R. & L. FRIEDLANDER, New York City.

MILFORD, DEL., March 4th, 1891.

GENTLEMEN: It gives me pleasure to recommend to the trade your Monarch Main Springs, for American Watches. They are, without exception, the best Main Springs that I have ever used. I have tried all makes within the last 25 years, but have found none equal to the Monarch Springs. They are uniform in force and temper; out of 6 dozen springs, I have lost but two.

I remain, yours truly,

HENRY ERBSMEHL.

Try our Monarch American Main Springs, { \$12.00 PER GROSS.
\$1.00 PER DOZEN
POSITIVELY NO GOODS SOLD AT RETAIL.

Established 1872.

PLAINVILLE STOCK CO.

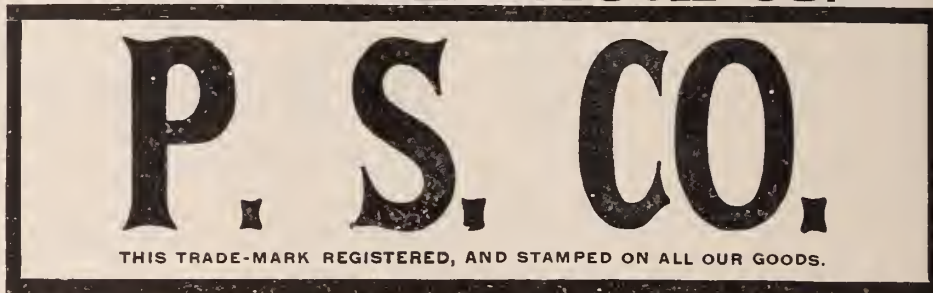

BROOCHES, SCARF PINS, DROPS, SETS.
FACTORY AT PLAINVILLE, MASS. SAMPLES AT 176 BROADWAY, NEW YORK

DIAMOND SETTINGS. GALLERIES. HOLLOW BALLS, ETC.

BLANCARD & CO.,

36 & 38 JOHN STREET,

SEND FOR OUR NEW YORK. CATALOGUE.

MUSICAL JACOT & SON,
298 Broadway,
New York

Send for Catalogue. **BOXES.**
Musical Boxes Repaired.

THE WALTHAM SCHOOL OF HOROLOGY,
D. D. PALMER, Teacher and Proprietor.
Best Advantages in the Country for Horological Instruction.

All branches under the personal supervision of D. D. PALMER, for a number of years in charge of the Adjusting Department of the Waltham Watch Co. POSITIONS GUARANTEED TO APT PUPILS. For terms and other particulars, address

D. D. PALMER,
WALTHAM, MASS.
Specialty of Difficult Repair Jobs.

GILBERT T. WOGLOM,
BLACK MAKER OF
PEARL ORNAMENTED
AND PLAIN
JEWELRY. **ONYX**
GOLD MOUNTED.
32 & 34 John St. New York City.



Town Talk.

In conversation with a CIRCULAR reporter recently a well-known diamond dealer said: "Very few people outside of the trade have any idea of what effect stormy or cloudy weather have on the diamond business. On days which are overcast, little or no business is transacted among the firms which deal exclusively in diamonds. This is accounted for by the fact that no dealer will undertake to buy goods when the condition of the atmosphere is such as to preclude the possibility of his being competent to judge the color, brilliancy, and in consequence, the value of diamonds. Of course it must be a very dark day before a dealer will lose a sale for want of confidence in his ability to value a stone, but the general effect of cloudy weather is to dealers then, when possible, to delay their purchases until the sun shows his face, again."

When asked for his opinions on jewelry, De Wolf Hopper, the well-known comedian, recently said: "Diamonds are like babies. They are both small and of infinite value. At least that is the opinion I once entertained. Since then I have come to the conclusion that diamonds have the best market value, and besides a fellow would rather nurse a large healthy diamond through the dark hours of the frosty night than he would perform the same office for a squalling, squirming, underdone infant. Among the barrels of jewelry which I possess is a ring, a diamond, ruby and sapphire. To the latter stone I attach much importance. It is my mascot and I would not part with it for the best engagement on record. A few years ago while wearing it circled with diamonds in a scarf pin, I attended an Actors' Fund concert at the Academy of Music, and while seated in the balcony was called upon to sing. I sang. At the conclusion of the warble the people left the theatre and I followed. When out on the sidewalk I discovered that my sapphire had fallen from its setting and was probably lost.

"With a beating heart and a few friends, I returned to where I had been seated during the evening, and began, as I thought, a hopeless search for the gem. Imagine my surprise, when the light from the sulphur match which I held showed the sapphire snugly resting under the seat. About a year after, the diamond of a ring I was wearing was lost in a similar manner and at a like gathering. As before, I discovered my loss when on the street. Returning to where I had been seated, I struck a match, and, remarkable to relate (I could never account for it), I failed to find it. Strange, wasn't it?

"On ladies, I like to see a dark stone necklace; that is, if they have a shapely throat. In my opinion, it enhances their natural beauty. On those who are not blessed with good looks, I like—but—you know, there are things, yes, there *are* things 'tis better not to dwell on."

WATCH * CASE * REPAIRING

WITH MY



IMPROVED MACHINERY and INCREASED FACILITIES,



I am enabled to do your work

BETTER,

QUICKER AND

CHEAPER.

IT IS TO

YOUR ADVANTAGE

TO GIVE ME A TRIAL.

G. F. FEINIER,

Manufacturer of Watch Cases; also Repairing of Every Description.

No. 9 Bond Street, New York.

Key-Wind Cases Altered to Stem-Wind, and made same as New. English Cases Altered to take American Movements.

REFERENCE: ROBBINS & APPLETON, NEW YORK.

W. ROSENTALL,

 Manufacturer of
SILK VEST CHAINS,
 79 NASSAU STREET, NEW YORK.
 Send for Selection Package with reference.

F&B Stamped on our cards or tags means that the goods are made to give satisfaction.
TRADE MARK
FOSTER & BAILEY,
 PROVIDENCE, R. I.



The Latest "PURITAN" Design.

RICH CUT GLASSWARE.



Headquarters in America for
ART GLASSWARES,
 RICH CUT AND DECORATED.
 Lamps, Vases and complete lines of everything for table use or household decoration.

MT. WASHINGTON GLASS CO.

NEW BEDFORD, MASS. CATALOGUES FOR * * * * *
 NEW YORK OFFICE, 46 MURRAY STREET. * * * * * INTENDING PURCHASERS.



MOORE & HORTON,
 MANUFACTURERS OF
SOLID GOLD JEWELRY,
 No. 11 Maiden Lane, New York.
Fine Imitation Diamond Goods a Specialty.
 Selection Packages sent on Application.

ALVIN MFG. CO.,
Silversmiths,
 860 Broadway, New York,
 206 Kearney St., San Francisco.



DESIGN—OYSTER SHELL—SALT.
 MADE IN LARGER SIZES FOR ASH
 TRAYS, &c.
Design Patented.

ALEX. WIEDERHOLD,
 20 MAIDEN LANE, N. Y.,
REPAIRING JEWELER.

Jobbing sent to me by mail or express will be repaired and returned promptly. Prices Moderate and First-class Workmanship Guaranteed.

"THIS RING, WHOSE HIGH RESPECT AND RICH VALIDITY
 DID LACK A PARALLEL."—SHAKESPEARE.

HILDRETH MANUFACTURING COMPANY,
 53 MAIDEN LANE, NEW YORK.

PLAIN SOLID GOLD RINGS AT LOWER PRICES THAN YOU
 ARE PAYING. SEND FOR SAMPLES. QUALITY GUARANTEED.

KENDRICK & DAVIS,
LEBANON, N. H.

MANUFACTURERS OF THE

Standard Dust Proof Watch Key.



*After this date all Keys of this Style will have number
 stamped on each Key.*

FOR SALE BY THE TRADE.

A man whose opinion is much sought after, and which is never given until after careful deliberation of the subject involved, is David Keller, the jovial member of the firm of Keller, Ettinger & Fink. Besides being the treasurer and a director of the New York Jewelers' Board of Trade, Mr. Keller is one of the old time Free Sons. He occupies the honorable position of Grand Treasurer of that order, an office he has filled many years.

"To demonstrate what the majority of people know of the value of precious stones," said a salesman for a Providence jewelry firm in the rotunda of the Astor House, "some friends and I were in an uptown café a short time ago. Among us was a dressy young man, who wore a big diamond pin. We did not know the young fellow very well but we thought we would quiz him on the subject of his diamond, to pass the time. Being in the jewelry business I was delegated to commence.

"If that was a diamond," said I to the young man, "it would be worth a good sum."

"If it was!" he exclaimed, "why, man, I gave \$150 for it, and it's worth \$300. Bought it of a fellow who was deuced low."

"We use those stones down in Providence in making brooches that retail for a dollar. We sometimes put two or even three in a single piece that sells for the same price."

"What! you say this is not a diamond?"

"Assuredly not," responded I.
 The young man's face became blanched. He was turned toward the window, and as some one passed outside he gave an exclamation and rushed from the café. He returned in a few minutes with his face aglow, but without the pin. We asked him what he had done with it.

"Did you notice the young fellow that passed? Well he had often offered me \$50 for that pin. I've sold it to him."

"We all fell back. That stone was a fine brilliant, worth \$300!"

The Banking Pins.—When the balance has been cleaned, put it in its place, try its end shake, and, if necessary, correct it. If it has more than perceptible end shake, you may expect irregularity in the time-keeping of the watch; the shake of the impulse pin in the lever watch is not very likely to be wrong, but it should be seen to, as the least side shake here will lessen the vibration of the balance. The position of the banking-pins is likely to be more uncertain, as one of the expedients of repairers is when the cleaned-out watch will not go, to bend these pins either out or in. Although a lever watch will go, it will not go well with the banking-pins too wide apart, in consequence of the great amount of run the wheel teeth have on the pallets, and therefore the closer the banking the better, if the guard pin is free of the roller in all positions.

SEE OUR INDUCEMENTS TO NEW SUBSCRIBERS ON PAGE 37.

Brief History of Gold and Silversmithing.

(Continued from page 44, March 11.)

PART V.

LOUIS XVI. AND EMPIRE.

DURING the last quarter of the eighteenth century, gold and silver wares offered, generally speaking, no great originality, excepting in the small lines, which include bon-bon boxes, snuff boxes, cane tops, etc. Yet, a few pieces of a larger size deserve to be mentioned. Our fig. 25 reproduces a silver soup-tureen made by Pierre Germain, for the Empress Catherine II. of Russia. It exhibits a style of the transition period, between those of Louis XV. and Louis XVI. It belonged to a set given by the illustrious Empress to Prince Potemkin, the most eminent among her numerous favorites, after his victorious campaign against the Turks.

The body of that tureen consists of two parts. The lower one has the shape of a cup, resting on four feet. It is decorated with godroons, partly hidden with applied laurel garlands, caught symmetrically by four bow-knots. The top part is adorned with two medallions, one of which exhibits the triumph of Potemkin, and the other one, Bellone sparing conquered foes. The cover is crowned with a military trophy, on which stands a feathered helmet. All the ornamental foliage was finished in dull silver on a polished background. This handsome tureen now belongs to Baron Gustave de Rothschild.

Our fig. 26 shows a very remarkable chalice designed by J. Forty. All the details of that unique cup come out so perfectly in the illustration that I think it unnecessary to describe them. It would be difficult to find, in the line I consider here, a specimen of the silversmith's art of that period so strikingly



FIG. 25. SOUP TUREEN, BY P. GERMAIN.

exhibiting the characteristic features of the Louis XVI. style.

I ought, at least, to mention the Empire

period, although the chief endeavors of the artists who lived in that time seem to have been to prove to us that Egyptians, Greeks



FIG. 26. CHALICE, BY J. FORTY.

and Romans were, after all, but a very dull lot. The tea-urn reproduced by our fig. 27, sufficiently illustrates the style that I presume was the rage (if such a word were not misplaced in the present case) at the beginning of this century. Ornaments in the shape of a lotus, sphinxes, mythological figures and other items of the old stock are noticeable on that work, which was designed by Percier and Fontaine.

(To be continued.)

Timing in Positions.

TO adjust a watch so that it has the same rate when placed first in a horizontal and then in a vertical position, is a delicate and often difficult operation; thus it is seldom found to be properly done in ordinary watches. THE JEWELERS' CIRCULAR will at no distant date endeavor to describe the *modus operandi*, and at this time confines its remarks to summarizing such of the directions as have a bearing on every-day work.

The rates in a vertical and horizontal position, says Cl. Saunier, are made identical or nearly so by equalizing the resistance that

interferes with the motion of the balanced in the two cases, and by taking advantage of the displacement of the centre of gravity of the balance spring.

Satisfactory results will be obtained in most cases by employing the following methods, either separately or two or more together, according to the results of experiments or the rates; the experience and the judgment of the workman:

1. Flatten slightly the ends of the balance pivots so as to increase their radii of friction; when the watch is lying flat, the friction will become greater.

2. Let the thickness of the jewel holes be no more than is absolutely necessary. It is sometimes thought sufficient to chamfer the jewel hole so as to reduce the surface on which friction occurs; but this does not quite meet the case since an appreciable column of oil is maintained against the pivot.

3. Reduce the diameters of the pivots, of course changing the jewel holes. The resistance due to friction, when the watch is vertical, increases rapidly with any increase in the diameters of pivots.

4. Let the balance spring be accurately centered, or it must usually be so placed that the lateral pull tends to lift the balance when the watch is hanging vertical. In this and the next succeeding case it would sometimes be advantageous to be able to change the point at which it is fixed; but this is seldom possible.

5. Replace the balance spring by one that is longer or shorter, but of the same strength; this is with a view to increase or diminish the lateral pressure, in accordance with the explanations given in the last paragraph.

6. Set the escapement so that the strongest impulse corresponds with the greatest resistance of the balance.

7. Replace the balance. A balance that is too heavy renders the timing for position impossible.



FIG. 27. TEA URN—ROMAN EMPIRE PERIOD.

8. Lastly, when these methods are inapplicable or insufficient, there only remains the very common practice of setting the balance 'out of poise.'

ARE YOU DISSOLVING PARTNERSHIP
 ARE YOU HAVING DULL TRADE
 ARE YOU ABOUT TO RETIRE
 ARE YOU OVERSTOCKED
 ARE YOU REMOVING

IF YOU ARE, COMMUNICATE WITH

A. J. COMRIE,
 AUCTIONEER,

Specialty of Jewelers' Sales. 16 West 125th St., New York.



The Highest Grade
 — OF —
 Electro Silver
 Plated Ware

Is Stamped with the
 **ROGERS TRADE-MARKS.**
 MANUFACTURED BY
The Wm. Rogers Manufacturing Co.,
 P. O. DRAWER 30,
 HARTFORD, - CONN



UNITED · STATES · OPTICAL · CO.

15 Grand River Ave., Detroit, Mich.

MANUFACTURERS AND JOBBERS OF

SPECTACLES and EYE GLASSES.

Special Attention given to Prescription Work, and Repairing by Skilled Workmen.

Our facilities for the manufacture of SPECTACLE and EYE GLASS CASES are such that we can quote lowest prices.

WILL FURNISH SAMPLES ON APPLICATION.

If there is a gain in the vertical hanging position, slightly reduce the lower side of the balance; the oscillations will increase somewhat in extent, and there will be a losing rate in this position.

The contrary must be done in the opposite case. When the vibration exceeds a whole turn, the changes will be the reverse of those indicated. This fact must not be forgotten, especially in regard to the duplex and lever escapements, which may at first make a vibration of more than a turn, and subsequently less, according to the state of the oil.

We would again observe that the timing of a watch for position presents some difficulty, and it will only be after making a number of trials and studying the articles already quoted that the watchmaker will be able to accomplish it with certainty.

The Mainspring.

THERE has been much controversy concerning the best method of attaching a mainspring to a going barrel, and remarks increasing the volume of testimony would decidedly be out of place; nor would it be of much use to a watch repairer, as that matter is usually settled for them, since a new spring to be inserted must be fastened in the same manner as its predecessor has been.

It is now the universal practice to put a simple steel hook in the barrel and a hole in the end of the spring, and it is only necessary to see that the hook projects very little beyond the eye of the spring, and that it is at a sufficient angle to prevent the spring from slipping off. The hole in the spring should be oblong, and may be made with the lever-punch, which is much used for this purpose. The hole should be square at the end and beveled off from the inside to give a good hold on the hook; and the end of the spring beyond the hole should not be left longer than what is required for strength, but should be made square at the end, and rounded off from the outside.

Mainsprings are often found choked up, by having a quantity of oil put to them, which has not been removed when other parts of the watch were cleaned. The spring in a fusee watch should not be lubricated; all that is necessary is to see that the spring is put into the barrel in such a state that it will not rust; and the best way to insure this is to apply a small quantity of oil to a narrow strip of wash-leather and draw the spring through it, before winding it into the barrel.

If a strong mainspring breaks in a going barrel, it sometimes breaks a leaf or two out of the center pinion, as neither Swiss nor English watches are furnished with the patent pinion, but a broken third wheel pivot will often be found to be the result; and if the spaces of the center pinion were cut round at the bottom, as they should be, any invention in this direction would be of little use, in so far as the center pinion is concerned. But pivots are broken from many causes and must be replaced.

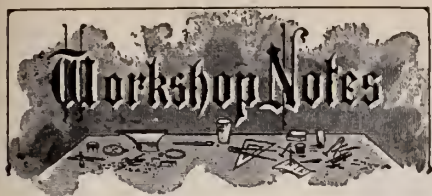

Isochronism.—There are two fundamental conditions which must be remembered when making the vibrations of the balance and spring isochronous, viz.: 1. The centre of gravity of the whole spring must be upon the axis of the balance and rest there during the movement. The spring does not in its action exert any lateral effort against the balance pivots.

Brass Tweezers.—The repairer will find that the most useful utensils on his bench are brass tweezers, which can easily be made from a well-hammered piece of sheet brass; they only require occasional filing to keep them always in good condition, and there is no chance of scratching or marking polished work with them. One of the commonest ways of spoiling good work is by using bad screwdrivers, for which there is no excuse, as the worst of workmen can make his own and keep them in perfect order. Hard brass wire with short wooden handles should be used for all but the smallest screwdrivers, unless it be for extracting rusty screws, when steel ones should of course be used; and small ones for jewel screws, etc., should fit the notch in the screw and be nearly as wide as the head of it. As for turns, files, broaches, gravers, etc., they will always be good or bad according to the means and taste of the possessor.

To Make Aluminum Gold.—To make aluminum gold or bronze, melt 90 parts copper with soda and borax as a flux, then add 10 parts aluminum (all by weight), a little at a time, by putting small pieces in a split stick of hard wood and pushing it down to the bottom of the crucible. This mixture is of the color of gold, tough and malleable, and does not tarnish.

To Melt and Refine Gold.—In melting brass gold, urge the fire to a great heat and stir the metal with the long stem of a tobacco pipe to prevent honey-combing. If steel or iron filings get into gold while melting, throw in a piece of sandiver the size of a common nut; it will attract the iron or steel from the gold into the flux, or sublimate of mercury will destroy the iron or steel. To cause gold to roll well melt with a good heat, add a tablespoonful of sal-ammoniac and charcoal, equal quantities, both pulverized; stir up well, put on the cover for two minutes, and pour.

Transparent Blue for Steel.—Damer varnish, ½ gallon; finely pulverized Prussian blue, ½ oz.; mix thoroughly. Makes a splendid appearance. Excellent for bluing hands.

SEE OUR INDUCEMENTS TO NEW SUBSCRIBERS ON PAGE 37.

THE BOWDEN Seamless Plain Ring,

IS MADE ONLY BY

J. B. BOWDEN & CO.,

Makers of FINGER RINGS of
every Description,

COR. BROADWAY & JOHN STREET,
NEW YORK.

A. WITTNAUER,

30 Maiden Lane, New York,

MAKER OF

COMPLICATED * WATCHES.

TIMING WATCHES

OF ALL STYLES.



SPLIT SECONDS

AND

Minute Repeaters.

VARIOUS GRADES, ALL ACCURATELY MADE.

Also Sole Agent for the Celebrated LONGINES & AGASSIZ Watches.

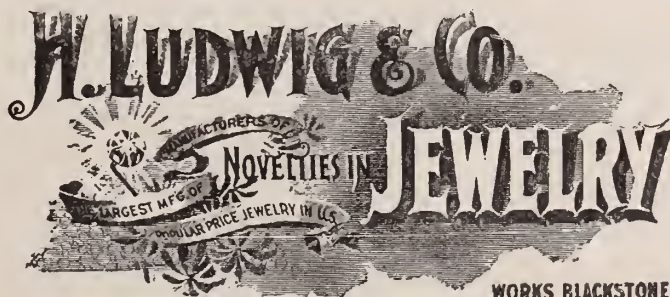

NEW YORK OFFICE,

PRESCOTT BUILDING,
ROOM 40 SAMPLES ONLY.

WORKS, BLACKSTONE & GAY STS.
TAKEN PRAIRIE AVE CAR

Providence, R.I.

The Other Side of Life.

HE WAS A GREAT TRAVELER.

Scene. I.

MR. J. MONTGOMERY BOBS-JONES—Let me have fifty plain spoons.

SILVERSMITH—All right, sir.

MR. J. M. BOBS-JONES—And engrave or etch on them the names of every city in Europe, Africa and Asia.

Scene. II.

MR. J. MONTGOMERY BOBS-JONES—I collected these spoons during my trip, as souvenirs, one spoon in each city. This one was given me by the Shah of Persia at Teheran, this by the Cadi of Bassorah, this by Mozak of Yarkand, this by the Duke—

MR. SHEYSTER DE PEUYSTER.—What a gweat twaveler you must be!

PARTICULARLY APPROPRIATE.

JEWELER (in Chicago)—We must get up some souvenir spoons for this city.

DESIGNER—Have you any ideas?

JEWELER—Well I have been thinking that a divorce decree etched in the bowl, and a little hog in relief on the handle would be pretty and appropriate.

A GREAT INSURANCE.

PONSONBY—We have organized a good benefit society. We have to pay only \$1 a week while we live.

POPINJAY—Well, that's not so good.

PONSONBY—But we get \$2 a week while we're dead.

"Why did you give up calling on Miss Ansonia?"

"No man can make love successfully to a woman who persists in keeping a cuckoo clock."—*Puck*.



THE SOCIETY DETECTIVE.

MISS FADD—What treasures Mrs. Buhl has here in this cabinet of heirlooms! This sword, she says, was presented to her great grandfather by Lafayette. Perhaps you can tell me the history of this snuff-box?

ARCHIE HOLOGIST—Yes; it was loaned for the evening by the janitor of the Antiquarian Society.—*Puck*.

Time is money because it slips away fast.—*Pittsburgh Chronicle*.

A LETTER OF REGRET.

Messrs. Donnop, Brown & Co.:

I have gone away after robbing \$5,000 worth of jewelry from your stock. My mind is eaten with remorse, so I send you a por-

tion of the pawn-tickets; when my mind is again eaten with remorse I shall send you some more. Yours sorrowfully,
CHARLES SLIMPOCKET.

NO WONDER.

"You don't seem very well this morning," remarked the chain to the watch.

"No," replied the watch, "I'm all run down."—*Epoch*.

A TENDER CONSCIENCE

FIRST BURGLAR—"Let's crack Cashier's safe to-morrow night."

SECOND BURGLAR—"That'll be Sunday."

FIRST BURGLAR—"Well?"

SECOND BURGLAR—"Well; d'ye suppose I'd break the Sabbath like that?"—*Judge*.

GLADYS—Why do you carry that lorgnette, Madge? Your eyesight is perfect.

MADGE—I keep it to snub people with.—*N. Y. Herald*.

A souvenir spoon—a booted lover.

UTTERLY IMPOSSIBLE.

ALICE—I don't see Agnes at church any more.

GWENDOLIN—No. You know Queen Elizabeth style of collars becomes her well; but her prayer book is decorated with Roman gold. So you see she can't be inconsistent.

Essex Watch Case

COMPANY,

T. B. HAGSTOZ, President.

TRADE MARK



6 Maiden Lane, N. Y.

OFFICE,

NEWARK, N. J.

FACTORY,

GOLD FILLED CASES.

ESTABLISHED 1837.

TAYLOR & BROTHER,

OLD HOUSE READ, TAYLOR & CO.

IMPORTERS OF

DIAMONDS and PRECIOUS STONES,

CLOCKS and BRONZES,

860 Broadway, cor. 17th Street, N. Y.

Branch Office for Clocks and Bronzes,

1½ MAIDEN LANE N. Y.



ROGERS & BRO. A-1.

OLDEST BRAND AND HIGHEST GRADE OF

ELECTRO SILVER PLATE.

ROGERS & BROTHER, Manufacturers,

16 Cortlandt Street, New York.

Waterbury, Conn.



HOLLOW WARE.

Photograph Albums and Price Lists upon Application accompanied by Business Card.

JOHN B. YATES,
No. 147 NASSAU STREET, NEW YORK.

WATCHES

SPECIALTIES: UNITED STATES WATCHES



I have a limited number of Discontinued American Waltham Gilt Hunting, price formerly \$12.65, same grade as the "Taylor" (Elgin) Movement, for \$10.50 Net.

ESTABLISHED 1856.
WILLIAM PARK,
Stone Seal Engraver,
 Arms, Crests in the highest style of Art. Also Gold Rings, Silver Seals, Brass and Steel Seals engraved SUPERIOR to Stone Seal engraving. Dies cut for Envelope Stamping in best Style.
 26 JOHN STREET, N. Y.

WOOD & HUGHES,
 Sterling Silverware Manufacturers.
 New York Agents for the Derby Silver Co.'s
FINE QUADRUPLED PLATED WARE.
 No. 16 JOHN STREET, - NEW YORK.
 206 Kearney St., San Francisco, Cal.
 HASKELL & MUEGGE, Agents.

ELGIN HOROLOGICAL SCHOOL
 ELGIN, ILL.
 SEND FOR CIRCULAR.
 Repairing for the trade. Repair price list free.

HENRY FERA,
IMPORTER OF DIAMONDS,
 AND DIAMOND BORTZ,
 Diamond Cutting and Polishing Establishment,
 10 Maiden Lane, NEW YORK

GENTLEMEN:—I think the trade this Spring will be better than last, and, although I can turn out double the work I did then, you had better be on hand with your orders, for I expect that my sales will be very large—equal to last Fall, if not double. You see the field is constantly widening and the demand is increasing, and why? Did you ever stop to think that there are 65,000,000 people in the United States, and the per cent. of this number that use glasses is one-fifth, or 20%, making 13,000,000 people wearing eye-glasses, and if you count the myriads in Europe and South America, why it is simply immense, and it needs cultivation. Why! Gentlemen, we ought to be able to double our business every year for the next ten years.

Yours respectfully,
 Springfield, Mass. S. F. MERRITT.

DAY & CLARK,
 MAKERS OF
FINE JEWELRY,
 BEAD NECKS AND BEAD BRACELETS
 CURB AND LINK BRACELETS
 STRICTLY 14 KT.
 10 MAIDEN LANE, N. Y.

ASSIGNEE'S SALE.

Assigned Estate of the Keystone Standard Watch Co., of Lancaster, Penn.

JAMES A. FREEMAN & CO., Auctioneers.

"THE LANCASTER WATCH FACTORY,"
LANCASTER, PA.

Thursday, April 16th, 1891,

At One O'clock, P. M.,

ON THE PREMISES.

REAL ESTATE.

All that certain tract or piece of land, situate and being in the City of Lancaster, whereon are erected a Brick Watch Factory Building and other improvements, and bounded and described as follows, to wit: Beginning at a post on the northern side of the Lancaster and Susquehanna Turnpike road; thence along the same N. 79 1-4°, W. 23 49-100 perches to a post; thence by land now or late of C. A. Bitner, N. 16 3-4°, E. 23 8-10 perches to a post; thence by the same land S. 73 1-4°, E. 23 42-100 perches to a post, and thence by land now or late of John C. Hager, S. 16 3-4°, W. 21 1-10 perches to the place of beginning, containing 3 acres and 46 perches of land.
 The improvements are a four-story brick main building, with three-story brick double

wing and towers; a one-story brick store room; a two-story brick dial house; a frame ice house; frame oil house; coal house; independent stack, &c. The main building is a substantial brick structure, well lighted and heated throughout with both live and exhaust steam. It is supplied throughout with gas and water fixtures. A tier of four (4) large fire-proof safes extend from basement to top floor of building. It is equipped with two (2) 30-horse-power boilers and one (1) 30-horse-power engine; 1030 feet line shafting, with all necessary hangers and pulleys; 5300 feet belting; 600 feet wall rods with counter-hangers for all the bench machinery, and 1370 feet benching with drawers.

Valuable Machinery, Special Tools, Micrometer and Standard Gauges, Stock, &c.

Included with the real estate will be the whole of the valuable machinery, special tools, micrometer and standard gauges, endless variety of small tools, &c., for the manufacture, engraving, damaskeening, gilding and finishing watch movements, manufacturing and finishing dials and all other parts. Also, the entire stock of finished and unfinished movements and parts thereof, including balance and train wheels; hour, second and minute hands; hair and main springs, pairs of rubies and sapphire jewels, bar holes, centre holes, end stones, &c., the itemized catalogue of which can be had on application to the Auctioneers. This plant is estimated to have cost over \$500,000.
 The above will be sold as a whole, subject to a mortgage of \$50,000, due on the first day of July, 1897, with interest at 6 per cent, per annum, payable half yearly, on the first day of

months of January and July each year in the meantime, and to the interest which fell due January 1, 1891.
 This factory, which is one of the most complete in the country, is located in the N. W. corner of Columbia and West End Avenues, Lancaster, Pa.; reached by the Lancaster & Millersville street cars from the Pennsylvania Railroad Station, or by the West End street cars from Centre Square. The buildings are situate in the rear centre of the lot on rising ground, thus affording ample and uninterrupted light, natural drainage and sufficient ground for additional buildings on the street.
 \$50,000 TO BE PAID AT THE TIME OF SALE.

Send for Catalogue, D. RAMSAY PATTERSON, Assignee, Office, 525 Drexel Building, Philadelphia, Pa.

FALKENAU, OPPENHEIMER & CO.,



40 MAIDEN LANE, NEW YORK.

P. O. BOX 3314.

CHAS. S. PLATT,

1937. Successor to George W. Platt, 1891.

GOLD AND SILVER

Refiner, Assayer and Sweep Smelter.

Office and Refinery,

29 & 31 GOLD ST., near John St., NEW YORK.

Platers' and Electro-Platers' Silver-Platinum and Aluminum.

Workshops to let, with power. Fine Light—special for Jewelers. All Improvements. Apply as above.



S. P. HOWARD,

Gold and Silver Assayer,

Refiner and Sweep Smelter,

8 & 10 JOHN STREET, NEW YORK.

Smelting and Refining Works,

28, 30 & 32 Cumberland St., Brooklyn, N. Y.

Specialties: Sweepings, Gold, Silver and Platinum.

"MONARCH"
THE ROGERS & HAMILTON CO.
WATERBURY, CONN.

ROBERTSON & LEBER,
GOLD, SILVER AND

PLATINUM

REFINING.

PLATINUM SCRAPS MELTED.

13 & 15 FRANKLIN STREET, NEWARK, N. J.

JEWELERS' SWEEPINGS A SPECIALTY

S. F. MYERS & CO., Wholesale Jewelers.

EVERYTHING
THAT
PERTAINS
TO THE
JEWELRY TRADE.

22
DEPARTMENTS.



WE REQUIRE
AND OCCUPY THE
LARGEST
SALESROOMS
IN OUR LINE.
4 STORES.
GROUND FLOOR.

48 & 50 Maiden Lane and 33 & 35 Liberty Street, New York.
CONSULT OUR MAMMOTH CATALOGUES.

L. LELONG & BRO.,

GOLD AND SILVER

Refiners, Assayers and Sweep Smelters,

◁ SOUTHWEST CORNER HALSEY AND MARSHALL STREETS, ▷
NEWARK, N. J.

SWEEPINGS A SPECIALTY.



COMPARE ALL OTHER GOLD FILLED CASES WITH THE CELEBRATED CROWN LION, EXECSIOR H. MURR'S SONS

Gold
AND
Diamond
Jewelry

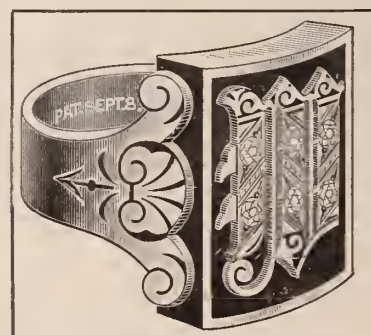
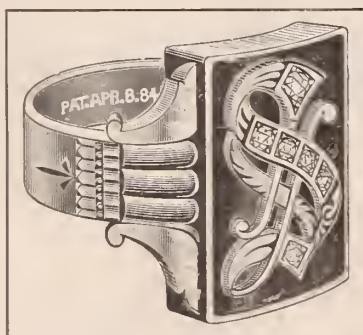

Gents' Seal,
Ladies' Fancy,
Children's Rings.

ALBERT LORSCH & CO., 37 Maiden Lane, New York.

P. O. BOX 2139.

167 Broad St. (Box 941), Providence, R. I.

IMPORTERS OF

DIAMONDS, PRECIOUS AND IMITATION STONES.

Sole owners and Importers of

Unequaled in

The Sumatra Gem.
REG'D.

Brilliancy.

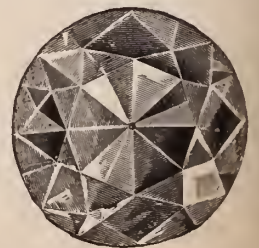
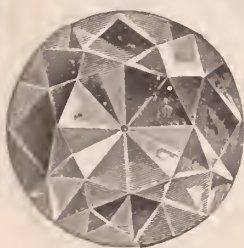

The nearest approach to the Genuine Diamond. For sale by all leading Manufacturers and Jobbers. All Jewelry set with these Stones is sold on cards stamped "The Sumatra Gem. Reg'd."

REMOVAL

GUNZBURGER BROTHERS, Importers of Diamonds

FROM 25 TO 25 MAIDEN LANE

CIRCULATION FOR
FEBRUARY,
40,150 COPIES.

SOUVENIR SPOON SERIES
NO 2.

LARGEST CIRCULATION
OF ALL THE
JEWELRY JOURNALS.



Entered at the Post Office in New York as second-class matter.

VOL. XXII.

NEW YORK, WEDNESDAY, APRIL 1, 1891.

No. 9.

SOUVENIR SPOONS.

PART II.

It is a natural consecution after considering the spoons referring New York to take up those of New England. Let us transport ourselves to that small compass and there abide. The six States, comprising an area equal to about one-fourth of Texas, are perhaps more fruitful in poetry, romance and legendary lore than the entire country besides. There began the real history of the country, and since 1614 when Capt. John Smith bestowed the name,

of Puritans who had been driven out of England by persecution sailed from Holland in July to found a community in America. After a long and boisterous voyage, they anchored in the harbor of Cape Cod, on November 11. Before landing, all the men signed an instrument, by which they com-

whole colony that arrived in New England. In parenthesis we may remark here that this handful of people added and multiplied enormously, if we are to believe the several million people who to-day claim that their ancestors came over on the Mayflower. To go back, after exploring the coast, the

Puritans agreed upon a place of settlement, and landed, December 22, on the rock which posterity has marked in commemoration of the Pilgrims. To this



THE LONGFELLOW, CHARTER OAK, WITCH, DEXTER AND WHITTIER SPOONS.

"New England," the territory has taken far more than its proportionate share of action in the affairs of the commonwealth.

It seems unnecessary to delve into history once more, but the settlement and events of early New England are ever absorbing in their narration. The first permanent settlement was commenced in 1620. A large number of the English congregation at Leyden formed

bined themselves into a body-politic, to be governed by the will of the majority, thereby establishing a republican form of government. This compact was signed by forty-one men, who, with their families constituted one hundred and one persons—the

settlement the name Plymouth was given in memory of the hospitalities which they had received at the English port.

THE PLYMOUTH ROCK SPOON

The little spoon gives an exact fac-simile of the famous rock as it stands to-day and as it stood two hundred and seventy years ago. The illustration scarcely reproduces the stone

as realistically as the spoon itself. The crevices and abrasures caused by time's wear, and natural formation are all seen in the silver. The oxidizing enhances the natural effect. The name Plymouth in peculiar semi-gothic letters is stamped on the handle. There is not much opportunity for artistic effect in the design of the spoon, but its historical significance and the excellent workmanship in its execution warrant the good demand for it the owners, Gooding Bros., Plymouth, Mass., enjoy.

THE SALEM WITCH.

Salem was the next city in Massachusetts that was settled, John Endicott and a hundred persons being the pioneers. The city may have passed down into history unknown and unthought of had it not been in its early history the centre of a terrible superstition, and later the birthplace of one of America's greatest writers, Nathaniel Hawthorne. One of the first acts of Sir William Phipps upon becoming governor of Massachusetts, in 1692, was the formation of a court to try certain persons who, because of their real or supposed strange conduct, were accused of practicing witchcraft. Most of the inhabitants of Salem and vicinity, where the accused parties lived, believed the accusations to be true; and before the delusion was dispelled twenty persons were put to death, more than fifty were tortured or frightened into confessing themselves guilty, and many suffered imprisonment. "The place of execution was a high hill," says Hawthorne, "on the outskirts of Salem; so that many of the sufferers, as they stood beneath the gallows, could discern their own habitations in the town; but the martyrdom of these guiltless persons seemed only to increase the madness."

Travelers cannot visit the old town without thoughts of the cruel madness, and the sale of the seven thousand witch spoons can hardly be marveled at. The design of this spoon, which is raised, is very appropriate, the witch, the pins with which the children who started the frenzy claimed to have been pricked with, and the very letters of the name, Salem, partaking of all the weirdness that the subject affords. The details of the figure of the witch are perfectly executed, the lean, long, bony arms, hands, fingers and facial features, the indescribable costume without beginning or end, and the broom, being such as all witches have—that is as far as our knowledge goes. There may be fair, fat and forty witches, but no one has ever seen them. Perhaps witches with those characteristics are designated as houris. In the first instalment of this article Daniel Low, Salem, Mass., who controls this spoon, was referred to as being the second jeweler in the country to introduce souvenir spoons. The witch is made for coffee, tea, orange, dessert, sugar, etc. Dr. Oliver Wendell Holmes, to drink his tea, uses a witch spoon that was presented to him by a lady as a token of his latest poem, the "Broomstick Train."

THE NUTMEG SPOON.

Connecticut, besides being known as the Land of Steady Habits, in allusion to the

staid deportment of its inhabitants, is also called, as every one knows, the Nutmeg State, "the inhabitants of which have such a reputation for shrewdness that they have been jocosely accused of palming off wooden nutmegs on unsuspecting purchasers instead of the genuine article." The writer was not cognizant of this reason until lately. He always had an idea that the simile was based upon the fact that both were strong and compassed within little space; or that Connecticut reminds one of the nutmeg because it is different, for while the spice is to be sneezed at, the inhabitants of the rocky hills of the State are not to be so treated.

The nutmeg spoon is among the handsomest the country has produced. Thoroughly emblematical, perfect in workmanship, the

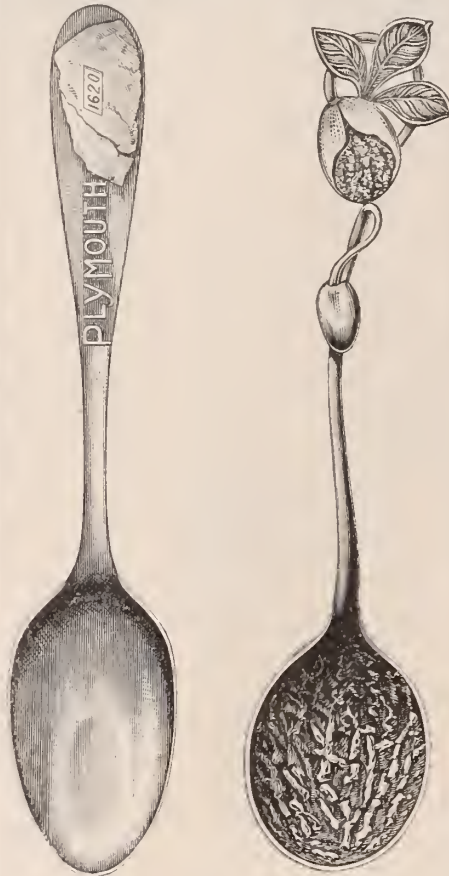

THE PLYMOUTH ROCK.

THE NUTMEG.

eyes never tire of examining its many beauties. The bowl represents a large-sized nutmeg, upon which a curving stem ascends. The head of the handle is a continuation of the stem, and comprises a nut in bud, with leaves of natural size spreading out in trefoil form. A budlet twines below. *Tout ensemble*, the design is extremely realistic, and reflects credit for artistic discrimination and ability upon whosoever conceived it. Hansell, Sloan & Co., Hartford, Conn., control the manufacture and sale of this spoon.

THE CHARTER OAK SPOON.

While speaking of staid Connecticut, the thread-bare story of the Charter Oak may be made still more thread-bare, for in commemoration of it a very attractive spoon has been devised. Sir Edmund Andros, who had been made royal Governor of New Eng-

land, in 1687 appeared before the Connecticut Assembly in session at Hartford, and demanding the surrender of the Connecticut charter, declared the Government under it to be dissolved. A discussion at once arose, which was protracted till evening, when the charter was brought in and laid upon the table; but just as Andros was stepping forward to take it, the lights were suddenly extinguished. When the candles were relighted, the document could not be found. It had been carried away and hid in the hollow of a tree. That tree, known in history as the Charter Oak, was held in veneration until it was blown down by a storm, more than 150 years afterward. Brodhead's History of New York and Palfrey's of New England treat this story as a tradition. Palfrey says: "No writing of the period alludes to this remarkable occurrence."

The old oak spreads its time-worn and storm-beaten limbs at the head of the spoon, and the historical hollow undoubtedly caused by lightning, is disclosed to view. A portion of the field in which the tree stood is also seen, and the contrast of the oxidizing of the branches with the bright background, gives the effect of an horizon. The letters of the words, Hartford, Conn., ornamented with a scroll, are arranged perpendicularly down the remainder of the handle. The words, Charter Oak, are stamped above, and 1687-9 below the tree. The back of the handle is decorated with twig-like scrolls. Altogether, the spoon is very artistic. It is controlled by the same house as controls the Nutmeg, and is made for coffee, tea, orange, and other purposes.

THE LORD TIMOTHY DEXTER SPOON.

The 26th of October is Lord Dexter's day at Newburyport, Mass. On that day, all true citizens bethink them of the genius whose exploits have found a prominent place in the facitious history of the world. Don Quixote never longed to be a Knight nor Sancho Panza a governor, more ardently, more actively than did Timothy Dexter long to be a lord. Fortune or rather lack of fortune had not deigned to have him born so, and as titles were unpurchasable at the time when he graced the earth with his presence, he hit upon an ingenious expedient of bestowing the title upon himself. Everybody called him Lord Dexter, and so he will go down in history. His other title, King of Chester, which he thought of adopting because he had a country seat in New Hampshire, was not successful. Lord Dexter astonished the world by his achievements in leather dressing, money broking, castle building, book writing, but the majority of his admirers seem to incline to his warming-pan achievement as his greatest exploit. To send warming-pans to the West Indies was verily a new thing under the sun. The wiseacres laughed at first but his lordship grinned broadly at the end. The pans found purchasers, and the pockets of the ingenious experimenter were lined with silver.

In commemoration of this remarkable personage, W. P. Jones, Newburyport, Mass.,

TRADE
SEAMLESS

MARK.

GOLD · FILLED · CHAINS.

ON ACCOUNT OF

THE great popularity of the chains made exclusively by us for the past three years, the air has been FILLED and the paper of the various Jewelers' Journals COVERED with the word "SEAMLESS" which has been and is our trade mark.

We never had such a boom in our business as we have had since our friends commenced to advertise our goods.

We have only a word to add, and that is we make and sell the

ORIGINAL AND GENUINE

SEAMLESS GOLD FILLED CHAINS.

In addition to the word SEAMLESS and for the protection of our customers we place upon each Chain a tag bearing the following trade-mark:



Which is affixed by authority of its owners, as a guarantee that the Chains are made from the Burdon Seamless Filled Wire.

<p>BOSTON OFFICE, 6 WINTER STREET, In charge of I. W. STELLE.</p>	<p>NEW YORK OFFICE, 17 Maiden Lane.</p>	<p>PACIFIC COAST AGENCY, WM. E. PETTES & Co., PHELAN BUILDING, SAN FRANCISCO, CAL.</p>
---	---	--

Address all communications to

KENT & STANLEY,
 PROVIDENCE, R. I.

SOLID SILVER

EXCLUSIVELY.



WHITING MFG. CO.

Silversmiths,

UNION SQUARE and 16th STREET,

NEW YORK.

We make solid silver only, and of but one grade—that of Sterling, $\frac{925}{1,000}$ fine; therefore purchasers secure an entire freedom from false impressions, and the question "Is it silver or is it plated?" is never raised concerning a gift bearing the above trade-mark. We have produced the largest variety of special *Souvenir Spoons* for the trade, made by any silversmith.

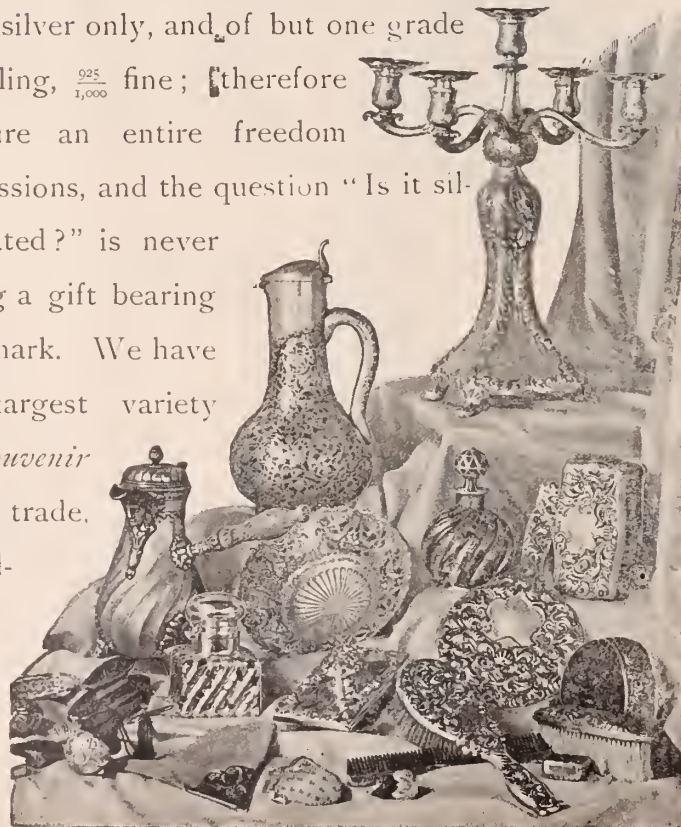

has produced an attractive spoon which shows the lord taking a walk accompanied by his dog. The mastodonian hat, the cane, the attitude, are all accurately reproduced. Above the hat, are the words Lord Timothy Dexter, and the name, Newburyport is arranged down the handle. The back of the handle displays a warming pan, half open.

PAUL REVERE SPOON.

Every bright school-boy has been called upon to recite Longfellow's poem on Paul Revere's Ride, and has rattled off with a ding-dong tone of voice,

"Listen, my children, and you shall hear,
Of the midnight ride of Paul Revere,
On the eighteenth of April in seventy-five;
Hardly a man is now alive,
Who remembers that famous day and year."

And so on, and on. Everyone knows how Paul Revere rode from Charlestown Neck, through Bedford town and Lexington, to Concord, crying his alarm to every Middlesex village and farm. The spoon which commemorates this patriotic incident in history, shows the hero on his horse warning the farmer at his door, after crossing the bridge at Concord. The design is a reproduction of the picture which is one of the earliest and pleasantest reminiscences of our school-days. The moon is setting behind the clouds, and the little village houses are seen in the dim dawn. The word Boston is etched in small letters at the end of the landscape near the bowl. The Shreve, Crump & Low Co., Boston, Mass., control the manufacture and sale of this emblem of early patriotism.

THE MOLL PITCHER SPOON.

Lynn, Mass., pays tribute to Moll Pitcher, a figure suggestive of the superstition prevalent among the settlers of New England. She seems to have been a subject of holy horror to mariners navigating the coast during the early days. They solemnly consulted her when they were about to leave their ports, and the predictions of the seer were implicitly believed in. Moll, of whom Whittier wrote, was undoubtedly a woman of education, great shrewdness and discernment.

The design in the spoon depicts the tall figure of the fortune-teller, leaning with both hands upon a staff or crutch, her head forward between bent shoulders. The black cat which lore tells us was her constant companion, is shown rubbing its sleeky sides along her legs. The workmanship of the figures brings out all the realistic effects, the



THE MOLL PITCHER.

THE
PAIRPOINT MFG. CO.,
 New Bedford, Mass.

FINE
GOLD AND SILVER PLATED WARE.

OUR LARGE LINE
 OF
STAPLES
 AND
NOVELTIES

WILL BEAR INSPECTION.



No. 1250. CAKE BASKET.

Quality
 Guaranteed.

NEW YORK.

CHICAGO.

SAN FRANCISCO.

PHILADELPHIA

SOUVENIR SPOONS.

A FINE ASSORTMENT

OF THE

MOST ARTISTIC AND SALABLE DESIGNS.



DAVID F. CONOVER & CO.,

SEND FOR SELECTION.

PHILADELPHIA, PA

lines and posture of age, and the wierdness of costume being perfectly reproduced. The words, Moll Pitcher, are in raised letters arranged diagonally under the figures, and the name Lynn in rustic, perpendicular letters is stamped down the remainder of the handle. The design altogether is a well-executed and characteristic one and reflects credit on its originator, W. F. Newhall, Lynn, Mass., who controls the sale and manufacture of the spoon.

All the preceding designs partake of historical or legendary significance. Those of an honorary or personal character will now be discussed. Perhaps the spoons of this nature which have become the widest known are the fine Whittier spoons, the Whittier Bust, the Residence, and the Captain's Well, owned by H. G. Hudson, Amesbury, Mass., and the Birthplace, owned by H. L. Dole, Haverhill, Mass.

Last November, H. G. Hudson, Amesbury, Mass., wrote his friend, John Greenleaf Whittier, the greatest of living American poets, for the permission to use his autograph on a souvenir spoon. The following reply was received :

DANVERS 12-22, 1890.

DEAR FRIEND :

I am pleased with the idea of the *Spoon*, and hope it will please my friends generally. I shall speak for *four* of them. I am truly thy friend,

JOHN G. WHITTIER.

The Whittier Bust spoon shows a fac-simile of the autograph on the front of the handle under an accurately executed bust of

the poet. On the back of the handle is the word, Amesbury in fancifully designed letters, ornamented with scrolls. The design of the spoon, though simple, is very attractive and peculiarly appropriate. It is made for tea, orange, dessert, sugar, etc.

The Residence spoon depicts at the top of the handle, the old-fashioned residence of the poet, in Amesbury. Here numerous curious travelers stop to examine the abode of the poet who has so often cheered their firesides, and to drink of the water of the Captain's Well, which the poet has made known to the world. Beneath the representation of the house, with its long fence and trees, is stamped the word Residence, and along the remainder of the handle, runs the fac-simile of the autograph. The design is not elaborate, and conjures before the mind a picture of the white haired old man passing the last years of his life away from the activity and strife of the larger world.

The Whittier Birthplace spoon, a very handsome article, is patented by H. L. Dole, Haverhill, Mass. The building stands about three miles outside that town. The representation shows to perfection the old farm house, with its surrounding shrubbery, the rickety fence, the roadway and the large tree that graces the pathway in front of the house. In this house, where eighty-five years ago the poet first saw the light, is seen at the present day, the identical nail on which the poet used to hang his watch, and the broad, open fire-place before which he wrote "Snow

Bound." The place is the goal of numerous travelers from all over the country, who buy the spoons which are on sale there, to take away with them as mementos of their visit. Above the representation of the house are the words, Whittier's Birthplace, and below the words, Haverhill, Mass. The spoon is made for tea, coffee, orange, sugar, etc. H. G. Hudson also has a Birthplace spoon. This dealer has regular Whittier days, when he decorates his windows with mementos and suggestions of the much loved citizen.

THE CAPTAIN'S WELL SPOON.

The spoon is so designated from an incident that occurred nearly a century ago in Amesbury. The well referred to was dug under quite dramatic circumstances. Capt. Valentine Bagley was wrecked off the coast of Arabia, July 10, 1792, and for fifty-nine days wandered over the deserts, suffering intensely for want of food and water. He was robbed by the natives of all his clothing and was thus exposed to the scorching rays of a tropical sun. Whittier, in a poem, "The Captain's Well," immortalizes the story :

"Pity me, God ! for I die of thirst ;
Take me out of this land accurst ;
And if ever I reach my home again,
Where earth has springs, and the sky has rain,
I will dig a well for the passers-by,
And none shall suffer with thirst as I,"

He was rescued and upon his return home in fulfilment of his vow, in 1796, dug a well which with the exception of a few years has

The R. Wallace & Sons Mfg. Co.,



No. 230 CUP. IN STERLING SILVER, TWO-THIRDS SIZE.

MANUFACTURERS OF

Sterling Silver, Plated Ware & Fine Cutlery

FACTORIES, WALLINGFORD, CONN.

{ New York Store: 3 Park Place.
Chicago Store: 104 State Street.

been kept open to the public. The spoon shows on the handle, this well, with the surrounding shrubbery, etc; it is covered by a gable hut, at the side of which is a trough. The details of the pail, rope, tap, etc., are accurately reproduced. Along the handle is the name of the poet, similar in execution to that in the other Hudson spoons. The back is of the same design as that in the Residence spoon.

THE LONGFELLOW SPOON.

The birth-place of Henry Wadsworth Longfellow was Portland, Me., and his youth and early manhood were passed in intimate associations with sea-life. In his half-autobiographical reverie, My Lost Youth, he records something of the effect which these associations had upon his mind, and gives a vivid picture of the city which has commemorated the greatest American poet, with a souvenir spoon.

Often I think of the beautiful town
That is seated by the sea;
Often in thought go up and down
The pleasant streets of that dear old town,
And my youth comes back to me,
And a verse of a Lapland song
Is haunting my memory still;
"A boy's will is the wind's will,
And the thoughts of youth are long, long thoughts."

The fine old poet, the creator of Miles Standish, Priscilla, Evangeline and Hiawatha, the mention of whose name conjures up all that is pure and perfect in literature, is a fitting subject for a souvenir design, and the silversmiths have grasped the opportunity to produce one of the most attractive articles of its class in the country. At the head of the handle, surrounded by a wreath of laurel, is a fine likeness of the celebrated poet. Beneath this is a monogram, of H. W. and L., while along the remainder of the handle, which is artistically broken with Louis XV. borders, are arranged perpendicularly odd-shaped letters, forming the word, Portland. The beauty of the design is enhanced by the interspersing of leaves. This spoon, owned by J. A. Merrill & Co., Portland, Me., is made for tea coffee, orange, pap, dessert and other purposes.

THE NEAL DOW SPOON.

While speaking of Portland, the other spoon emblematical of that city may be described. This is the Neal Dow spoon, designed in honor of the celebrated prohibitionist who was prominently instrumental in putting down spirits in the Eastern States. Persons of a facetious turn of mind, say that the spoons will assist in putting down more spirits, than his speeches and writings did. A bust of the reformer forms the head of the handle, the balance of which is formed of handsome architectural scroll designs. The bowl of the spoon depicts a view of the harbor, with ships in the docks, the gleaming water, and a sun shining through the clouds above the landscape. Behind the bust of Dow is his name in raised letters. The design which is well executed, the likeness being perfect and the landscape realistic, is controlled by Carter Bros., Portland, Me.

THE "CHARTER OAK."

Historic Souvenir of Hartford, Conn.

The Old Charter Oak, famous in the history of the Nutmeg State, is familiar to every child in the United States.

No Collection Complete
Without It.

Made in Orange, Coffee and Tea
Sizes.

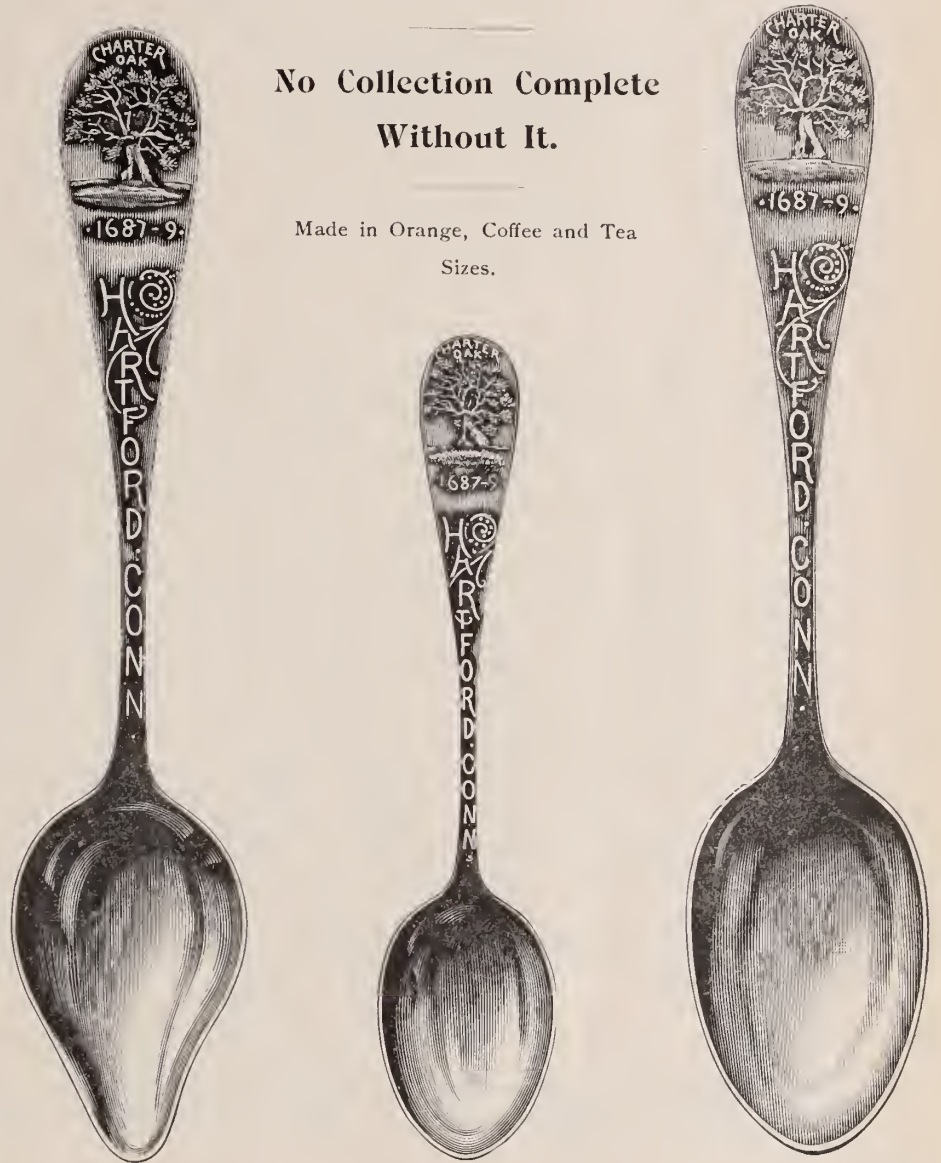

THE "NUTMEG" SPOON,



Beautiful Souvenir of the Nutmeg State.

Made in Coffee Size only.

DISCOUNT TO THE TRADE.

HANSELL, SLOAN & CO.,

Send for circulars and prices.

323 Main Street, HARTFORD, CONN.

THE BANCROFT WORCESTER SPOON.

The recent death of George Bancroft, the greatest of American historians, lends additional appropriateness to the tribute paid him, in comprising his likeness in a spoon, representing the place of his birth, Worcester, Mass. George Bancroft, was born Oct. 3, 1800, and his life's work won for him the honor of the nation, as one of her most illustrious sons. A few weeks previous to the death, a design for a spoon decoration was prepared by a member of the firm of A. F. Burbank, Worcester, Mass., which represented in sterling silver, a fine portrait medalion of the eminent citizen, on the front of the handle, and a fac-simile in relief, of his birthplace, the old Bancroft homestead, now standing on Salisbury St., on the reverse. The spoon is made for tea, orange, pap, sugar, etc.

Fitzsimmons the Centre of a Gang.

PITTSBURGH, Pa., March 25.—There appears to be little doubt that Fitzsimmons, who last Sunday shot dead Detective Gilkinson, is the leader of a gang that for two years past has robbed and burned dwellings and business houses at Duquesne, Homestead, Braddock and McKeesport, this county. His principal accomplice was Laura Snowden. Her most important exploit with Fitzsimmons was to detain Jeweler Schmitt, of Homestead, until after dark on Jan. 31, so that when he went to supper, Fitzsimmons could cut through the floor, purloin \$3,000 worth of jewelry and get away before Schmitt

returned. She was caught on a letter which incriminated herself, and when taken to jail was induced to confess.

Fitzsimmons will plead self-defense, and argue that he was in bed when the two detectives broke into his house; that the first knowledge he had of their presence was when he saw them struggling with his wife, and he fired before he knew they were officers. There are now six persons under arrest as accessories to the murder.

A Reward for Swenson's Body.

MONTREAL, P. Q., March 25.—The detectives have not yet secured any clue that would lead to the finding of Swenson, the missing jeweler, but are still on the search for him. J. F. Wulff, Royal Danish consul and Royal Swedish and Norwegian vice-consul, who is the curator of Swenson's estate, has received a letter from the missing man's brother, in which he is requested to look after Swenson's effects and to offer a reward of \$100 for information that will lead to the discovery of either his dead body or himself.

Jewelry Snatching Was a Failure.

COLUMBUS, O., March 25.—J. G. Adams, alias Tower, who was released from the penitentiary on Feb. 16, is again in the toils.

Some time after his release, he went to Cleveland, but instead of trying to lead an honest life, he adopted the profession of jewelry-snatching. He went into a jewelry store and asked to look at some watches.

A tray of gold watches was set out, and watching his opportunity, he snatched two watches and chains and escaped. He was known, however, to the jeweler, and officers were put on his track. A photograph of the thief was obtained and through it he was arrested while calling for his mail at the Post Office. The prisoner was taken to Cleveland.

Now Baltimore May Have A Watch Factory.

BALTIMORE, Md., March 25.—Some persons in Providence, R. I., have been in correspondence with business men in this city relative to the establishment of a watch manufactory here. The northern men say they desire to locate in the central South and are favorably disposed toward Baltimore, if sufficient concessions and inducements are offered here. Their object is to organize a stock company to erect the necessary buildings and equip the factory. At present they are operating in the North, and they express a willingness to invest \$50,000 in the stock.

The correspondence has been with John W. Middendorf, of Middendorf, Oliver & Co., and J. R. Bland, of the Merchants' and Manufacturers' Association. The Northern men have also been put in communication with W. B. Brooks, of the Canton Company, and Mr. William S. Rayner, of the South Baltimore Company. It is proposed, if the negotiations are successful, to trade chiefly with the South and to manufacture what is to be known as the "Baltimore Watch."

MULLER BRONZE CO.

Underhill & St. Marks Aves., BROOKLYN, N. Y.

MANUFACTURERS OF FINE

BRONZE ORNAMENTS FOR THE CLOCK AND JEWELRY TRADE.



HISTORY. No. 121.

ALL
FIRST CLASS JOBBERS
HANDLE THEM.

NEW CONCERN. NEW GOODS.



ARTIST. No. 112.

He Will Peddle Jewelry No More.

ALBANY, N. Y., March 26.—Thomas Williams, a jewelry peddler, residing in Chicago, Ill., while making the rounds of the disreputable resorts in this city on Tuesday night, was assaulted by three men in whose company he had been,

He was found by the police and taken to the Albany City Hospital, where he was supposed to have sustained only the injuries incident to a severe beating in a drunken brawl. He remained in an unconscious state until to-night, when he died.

A post mortem examination revealed, that the ferrule of an umbrella had been driven through his left eye, and penetrated three inches into his brain where a piece of it had remained.

Subsequently the police captured John Mulally, one of Williams's companions, and in his possession was an umbrella, from which the ferrule had been recently detached.

Much Jewelry Destroyed in a Train Wreck.

MILWAUKEE, Wis., March 25.—In the serious wreck that occurred on the Northwestern road at Racine Junction, last night, attended with loss of life, the safe of the American Express Co. became so hot from the fire, that on opening it at noon to-day half of the currency that it contained was found burned to ashes, and a large quantity of jewelry melted and run into one lump.

This jewelry is said to be the property of some Western jobbing jewelers, in transit to retailers. The first report placed the loss of jewelry at several thousands, though now the authorities of the company in this city say it reaches only several hundreds. The names of the merchants owning the goods are not given.

Masonic Jewels Redivivus.

GAINESVILLE, Ga., March 25. — Yesterday afternoon two young women walked out from Ellijay into the hills to gather wild flowers. As they were walking along one of them discovered a bright key on the ground and picked it up. The young women began to search for other articles, and after raking among the leaves and scratching in the loose earth they found a number of silver Masonic jewels of very fine workmanship, including a square, a plumb, a level, keys, etc. The keys were not crossed, but came apart.

The oldest members of the Masonic fraternity in this vicinity do not remember to have ever heard of the local lodge losing any such articles. Judging from the extra quality of these jewels they must have been there a great many years.

Right, You Are.

The JEWELERS' CIRCULAR, of New York, the leading jewelry and horological journal, has the following to say, etc.—*Erie (Pa) Observer.*

USE THE  **AMERICAN MAINSPRINGS**
FOR ALL KINDS OF AMERICAN WATCHES.
[FACSIMILE OF WRAPPER.]

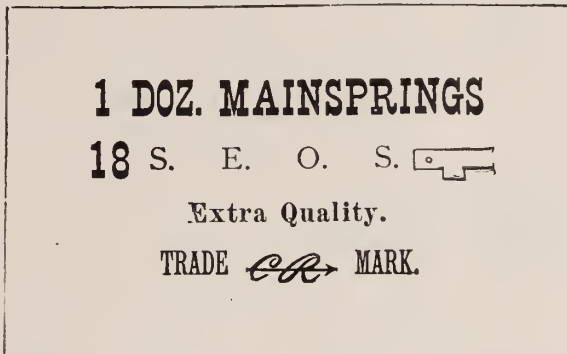

THE BEST IN THE MARKET.

L. H. KELLER & CO.,

Dealers in Fine Watch Materials and Tools.

AGENTS FOR THE PATEK, PHILIPPE & CO. WATCHES.

64 NASSAU STREET, NEW YORK.

S. C. JACKSON, 180 BROADWAY, NEW YORK,
MANUFACTURER OF

Fine * Cases * for * Jewelry, * Silverware, * Etc.,

ALSO SHOW CASE TRAYS AND FANCY HARD WOOD WORK.

Samples sent on application. Estimates furnished.

A. PINOVER & Co.,

IMPORTERS OF

DIAMONDS



AND

Manufacturing Jewelers,

25-29 ANN STREET,

Cor. Nassau Street. **NEW YORK.**

Novelties in Diamond Mountings.

DAY & CLARK,

MAKERS OF

FINE * JEWELRY,

BEAD NECKS AND BEAD BRACELETS.

CURB AND LINK BRACELETS

STRICTLY 14 KT.

10 MAIDEN LANE, N. Y.

GENTLEMEN:—I think the trade this Spring will be better than last, and, although I can turn out double the work I did then, you had better be on hand with your orders, for I expect that my sales will be very large—equal to last Fall, if not double. You see the field is constantly widening and the demand is increasing, and why? Did you ever stop to think that there are 65,000,000 people in the United States, and the per cent. of this number that use glasses is one-fifth, or 20 %, making 13,000,000 people wearing eyeglasses, and if you count the myriads in Europe and South America, why it is simply immense, and it needs cultivation. Why! Gentlemen, we ought to be able to double our business every year for the next ten years.

Yours respectfully,

Springfield, Mass. S. F. MERRITT.

HENRY TROEMNER,
No. 710 Market Street, PHILADELPHIA.

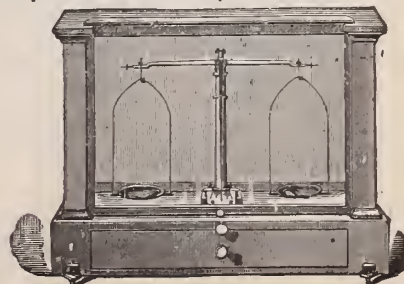

Manufacturer of FINE GOLD SCALES and DIAMOND SCALES Bullion Balances and Weights, in use at all the U. S. Mints and Assay Offices. Priced Catalogue on application.

ESTABLISHED 1837.
GEO. O. STREET & SONS,
 MAKERS OF
 Fine Rings, Locketts, Seals, Sleeve
 Buttons and Links,
 15 John Street, - NEW YORK.

WOOD & HUGHES,
 Sterling Silverware Manufacturers.
 New York Agents for the Derby Silver Co.'s
 FINE QUADRUPLED PLATED WARE.
 No. 16 JOHN STREET, - NEW YORK.
 206 Kearney St., San Francisco, Cal.
 HASKELL & MUEGGE, Agents.

ELGIN HOROLOGICAL SCHOOL
 ELGIN, ILL.

SEND FOR CIRCULAR.

Repairing for the trade. Repair price list free.

TO WHOLESALE DEALERS.
 WE HAVE FOR IMPORT
 A FINE LINE OF
BLACK FOREST
 (SCHWARZWALDER)
CUCKOO CLOCKS,
 With Brass Movements in dust-proof cases.
 E. R. SCHLENCKER, Manufacturer,
 Schwenningen a/ Neckar,
 WURTEMBERG, - - GERMANY.

BIRTHDAY * RINGS!

IN order to meet the increasing demand for BIRTHDAY RINGS, we have originated and Patented an attractive novelty in the shape of an elegant tray, containing of assorted patterns, 48 Rings, four for each month, with appropriate stones and the sentiments thereof, printed upon the tray in gilt letters.

As the whole four dozen cost but a very moderate amount, while we make no charge for the tray, which is of velvet and satin, as handsome as can be made, and the Rings it contains are of our latest and most desirable styles, we think that every Retailer will find it for both his interest and convenience to order this tray from us.

M. B. BRYANT & CO.,

* * RING MAKERS, * *

10 MAIDEN LANE, NEW YORK.

THE "BRYANT" INITIAL RING, easily interchangeable, still keeps the lead as the best made—SIMPLE, STRONG and HANDSOME—in trays of 6 or 12, with separate initials.

NIAGARA SOUVENIR SPOONS.

[Patent applied for.]



Made only in Sterling Silver, the design and die being controlled by us. The front shows in relief Prospect Point, the American and Horse Shoe Falls with Goat Island between, and the rapids flowing down the stem, which also bears, in light relief, the word "Niagara." The back of the handle is in DURGIN's beautiful Louis XV. pattern.

Tea-Spoons.....	\$2.00	Orange Spoons.....	\$2.75	Sugar Spoons.....	\$3.50
Coffee Spoons....	1.25	" gilt..	3.00	" gilt...	3.75
" gilt,	1.50	" all gilt..	3.75	" all gilt...	4.50
" all gilt,	2.00				

Wholesale Discount 15 per cent., less 5 per cent. 30 days.

W. H. GLENNY SONS & CO.,
 BUFFALO, N. Y.

Displays at the Jamaica Exhibition.

KINGSTON, Jamaica, March 15.—The Exhibition in this city was opened on Jan. 27 by Prince George of Wales, and has had already considerable success. The buildings and the grounds are carefully arranged and laid out. The buildings are not so extensive as those used at expositions in the United States and Europe, but for architectural beauty they are claimed to excel those of any previous exhibition.

The exhibits are arranged under the following heads: Group 1, raw materials; Group 2, implements for obtaining raw materials; Group 3, machines and processes used in preparing and making up the raw materials into finished products; Group 4, manufactured goods; Group 5, education; Group 6, fine arts, literature and science.

Among the exhibits that are of interest to the jewelry trade are those of the Ansonia Clock Co., of Ansonia, Conn., and New York, who display a very fine assortment of clocks and bronzes, and W. Harvey & Co., Philadelphia, Pa., and New York, who, among other things exhibit a case of ivory handles for walking sticks, and handles of horn, shell, carved

ivory and pearl for umbrellas. The first shelf of the case shows a line of cane handles in pearl and ivory, both plain white and antique, some carved and others mounted in silver. On the upper shelves there is a display of ivory, buckhorn and olive wood paper knives, and not the least important exhibit of the case is a sample of carved walrus and alligator ivory made into hooks. The ivory of the walrus is a pure white, but as the nerve cannot be extracted its value as an ornament is somewhat deteriorated. In a round stand, some four feet high, there is an assortment of sticks mounted in gold, silver and ivory, and several varieties of buckhorn with silver patches.

To have an Industrial Exhibit.

PROVIDENCE, R. I., March 25.—There has been considerable agitation in this city for some time past upon the subject of having an industrial exhibition, and this feeling seems to meet with favor, with all branches of business throughout the city. The matter has been talked of by some of the more progressive manufacturers and recently took tangible form when committees representing

the Providence Board of Trade, the Advance Club, the Manufacturing Jewelers' Board of Trade, the Commercial Club and the Business Men's Association met at the Narragansett Hotel, among them being Dutce Wilcox, president of the Jewelers' Board of Trade, and W. R. Dutemple and B. A. Ballou of the same organization. Remarks upon the subject were made by all the gentlemen present, each one being strongly in favor of the proposed scheme, several being of the opinion that such an exhibition would be a grand success and would greatly benefit the merchants and manufacturers of Rhode Island.

The following committee was appointed to visit the manufacturers of the State and get their support, and also to visit the members of the Mechanics' Fair Association in Boston and report all the details connected with the organization of that association: Chairman D. R. Brown, Col. E. H. Rockwell and H. C. Armstrong, and report at the next meeting to be called soon.

E. J. Pierpont, Naugatuck, Conn., is advertising one half his store and fixtures to rent.

SOUVENIR * SPOONS * IN * PIERCED * WORK.

THE FINEST AND MOST ORIGINAL STYLE.

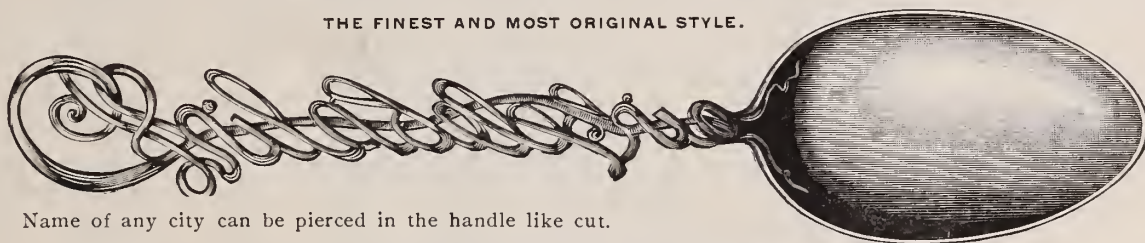

Name of any city can be pierced in the handle like cut.

Also Etching on Bowl or Handle.

MYRICK, ROLLER & HOLBROOK,

MANUFACTURING SILVERSMITHS.

1018 CHESTNUT STREET, Philadelphia. Pa.

WILLIAM B. DURGIN,

Designer and Maker of Wares in **STERLING SILVER,**

CONCORD, NEW HAMPSHIRE,

Cautions Manufacturers against infringement of Orange Spoon Bowl, as shown in accompanying cut, as it is fully protected by Letters-Patent.



MANUFACTURER OF FINEST LINE OF ORANGE SPOONS ON THE MARKET.

BY SPECIAL ARRANGEMENT, CERTAIN PROPRIETORS OF SOUVENIR SPOONS ARE PERMITTED TO USE THIS BOWL.

MAKER OF PAUL REVERE, NEW HAMPSHIRE AND PRISCILLA SOUVENIR SPOONS.

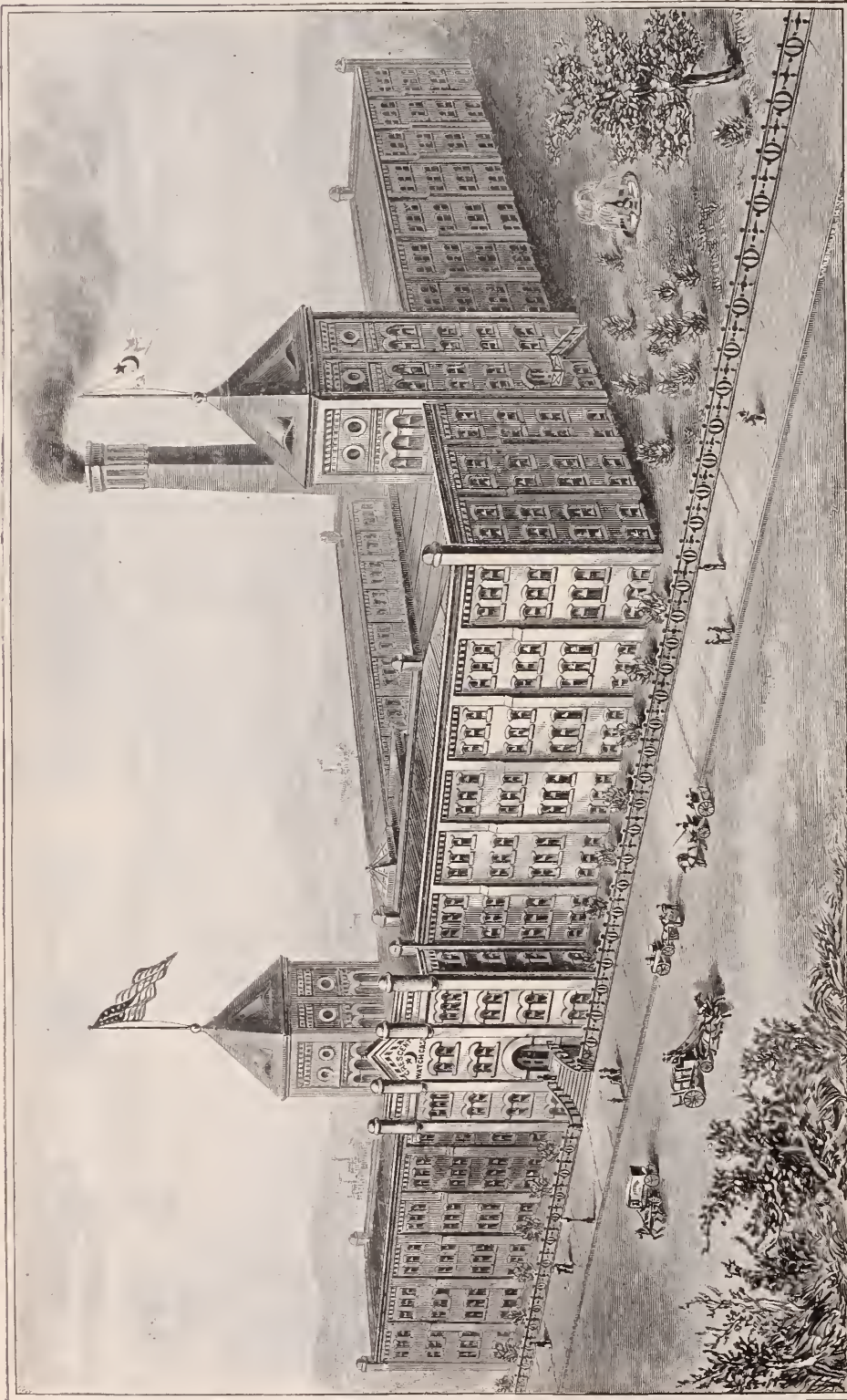

THE NEW FACTORY OF THE
CRESCENT WATCH CASE COMPANY,
NEWARK, N. J.

Another Watch Club Co. in Trouble.

DULUTH, Minn., March 25.—The Imperial Watch Co., Chicago, Ill., are in trouble again. The concern carries on an extensive watch club business. The company opened an agency here about a year ago, and organized several clubs. Probably one hundred watches were disposed of by their "chance" contracts when they were notified by W. A. Montague, of Montague & Co., 325 W. Superior St., to quit business or prosecution under the lottery law would follow.

Operations were suspended for a time, but two months ago members of the clubs received a notification that a new contract would be issued in which the "chance" clause would be stricken out. These notifications were followed by general traveling agent, Hallock Welles, who up to date according to his own statement has secured about four hundred subscribers to the Imperial clubs. On the charge that Mr. Welles not conducting a legitimate business, a combination of prominent dealers instituted an inquiry, and two detectives were employed who ascertained that the "chance" clause, though banished in the contract was supplied by a verbal agreement.

Last week agent Welles was arrested and his case is now before the municipal court. Mr. Montague, backed up by the combination, is instrumental in the prosecution.

Jewelers Make Easter Displays.

During the past week the show windows of many New York jewelry stores were attractive points, owing to their tasteful dressing in honor of the Easter holidays, and beginning of Spring.

The windows of the Meriden Britannia Co., 46 E. Fourteenth St., were very artistically

arranged. A background of green silk, lilies and other seasonable plants shaded numerous silver articles appropriate to the holidays. The foreground consisted of mirrors, simulating pools of water on which rested silver marine plants, while reptiles, such as frogs and lizards, of the same metal reposed on beds of white silk.

A cluster of Easter lilies planted in a blue china swan formed the decoration of J. H. Johnston & Co.'s window.

Virgin white silk on which the many gold trinkets showed to advantage, made Charles Casper's windows a more than ordinary attraction to the crowd.

Lilies and green foliage gave a fine effect to the display of Reed & Barton. The Broadway store of Gorham Mfg. Co., showed a large silver banquet rose receptacle filled with lilies, while on each side were silver stands containing other appropriate plants. The window of the Maiden Lane branch made a fine appearance. Silver-colored plush eggs nestling in white silk, and drooping lilies gave quite a picturesque effect.

The window of Benedict Bros., on Broadway, had its surface covered with white silk, on which rested jewelry in cases of a like color. In the centre on a small mirror were several scores of loose diamonds and emeralds which were apparently being pecked at by a small white dove. Suspended in the centre of the window was another dove holding in its beak a large diamond. Lilies intermingled with green foliage formed the background.

The windows of William Barthman, Silas Stuart, E. A. Thrall, O. M. Farrand, Cross & Beguelin, Leopold Stern, Pairpoint Mfg. Co. and C. W. Schumann were among the other downtown firms that exhibited Easter decorations.

CROSS & BEGUELIN,

21 Maiden Lane, N. Y.



MAKERS OF THE

CENTENNIAL TIMERS

AND

CENTENNIAL CHRONOGRAPHS.

IMPORTERS OF

DIAMONDS,

Watch Material, Opera Glasses, etc.

JOBBER OF ALL GRADES OF

AMERICAN WATCHES,

Gold and Rolled Plate Jewelry.

We carry a large stock—and are constantly adding all the LATEST designs of goods in our several departments—so that we are enabled to fill ALL orders with PROMPTNESS, which most dealers will appreciate.

Selection Package Sent on Satisfactory Reference.

SEND FOR PRICE LIST.

NOTICE.

The undersigned having purchased the interest of Mr. GEORGE OWEN in the firm of G. & S. OWEN & Co., have this day formed a new co-partnership under the firm name of SNOW & WESTCOTT, for the purpose of continuing the business heretofore carried on by the late firm of G. & S. OWEN & Co.

JAMES P. SNOW,
CHARLES E. WESTCOTT.

March 2, 1891.

THIS is a facsimile of the copyrighted label in colors, attached to every ream of genuine ROYAL GRASS BLEACHED SILVER TISSUE PAPER manufactured by us, and guaranteed absolutely pure. Its reliability as a wrapping for solid or plated goods is conceded by all who have used it, while the price is considerably less than is asked for foreign paper of this class. To determine the relative merits of our paper as compared with the imported tissue, we will gladly furnish samples, free of charge, to all manufacturers who may desire to test it. ROYAL GRASS BLEACHED SILVER TISSUE is sold by all paper dealers in the U. S. Write us for samples.

MILLS:

MILBURN, N. J.
HAMPTON, N. Y.
WHIPPANY, N. J.
PATERSON, N. J.

MANUFACTURED BY

DIAMOND MILLS PAPER CO.,

44 Murray Street, New York

THE LATEST PARISIAN NOVELTY.



MANUFACTURED BY

CROSSIN & TUCKER,
409 Pine Street, Providence, R. I.

WATCH DIALS.

Any kind watch dial duplicated within ten days. Factories supplied with dials for their entire product or with special designs for their high grade movements. Special rates for large quantities. Emblems, photographs, landscapes and ornamental work of every description on plain, enamel or under glaze.

WALTHAM DIAL CO.,

WALTHAM, MASS.

Ludwig Faber

Moore & Horton

18 JOHN ST. NEW YORK.

MOORE & HORTON,
MANUFACTURERS OF
SOLID GOLD JEWELRY,
No. 11 Maiden Lane, New York.
Fine Imitation Diamond Goods a Specialty.
Selection Packages sent on Application.

The New Trenton



18 SIZE, SEVEN JEWELS, NICKEL.
HUNTING AND OPEN FACE S. W.

Quick train, straight line lever escapement, safety centre pinion, enamel dial, beautifully damaskeened and exceedingly attractive in appearance.

**THE BEST LOW PRICED WATCH
EVER PRODUCED.**

For Sale by the Jobbing Trade.

TRENTON WATCH CO.

TRENTON, N. J.

ALEX. WIEDERHOLD,
20 MAIDEN LANE, N. Y.,
REPAIRING JEWELER.

Jobbing sent to me by mail or express will be repaired and returned promptly. Prices Moderate and First-class Workmanship Guaranteed.



FEATHERS IN BRILLIANTS STILL IN VOGUE—SILVER MOUNTED INKSTANDS VERY FASHIONABLE—OTHER FASHIONS—TROPHY TO PRESIDENT CARNOT.

PARIS, France, March, 21.—Feathers consisting of brilliants are still in fashion. A lovely one, gracefully curled, has just been made by Durand-Leriche. The chief object of the jeweler has been to reproduce the lightness and the soft appearance of an ostrich feather. To that effect, the brilliants have been set very flat, and close together; thus their shining power is somewhat subdued. It is really uncommon to spend no end of ingenuity in order to tone down to a mere glimmer the fire of sparkling stones. Most jewelers endeavor to make the very best of even their smallest gems.

Fashionable gentlemen's studs are in plain gold, round and flat, either sparingly incrustated with tiny stones such as rubies, sapphires, emeralds, amethysts and turquoises, or adorned with one large single stone.

A handsome brooch, in the shape of a shield, consists of medium sized white diamonds surrounding a pear-shaped black one. Bracelets now in favor are made of five narrow bands of flatly set brilliants. These bands, placed rather wide apart, are held together by two equi-distant bars similarly adorned and an elaborate ornament forming an elongated square clasp, consisting of diamonds of various sizes gathered around three large sapphires arranged as a trefoil.

Silver and gold teaspoons have always been considered, in France, as fancy articles; in consequence, the variety of decoration in that line is absolutely unlimited. Some teaspoon handles represent Egyptian or mythological figures; others exhibit at the base heads of historical men and women; a few show a succession of medals of various sizes gradually narrowing towards the top; many consist of twisted reeds and weeds; and several patterns are worked in repere, with precious stones symmetrically set from the base upwards.

Inkstands in silver have always been fashionable, but they never occupied so prominent a place in a silversmith's stock as they do now. Some stamped patterns in a florid style are very successful in export lines. Their massive appearance contrasting with a rather low price irresistibly attracts purchasers. A higher class of silver inkstands are exhibited in the Rue de la Paix. One consists of swelling waves, gradually rising forward from the base of the piece. A Venus, partly veiled with her rippling hair, stands on the culminating billows. Sirens, swimming on each side, uphold pretty ink receptacles in the shape of fancy shells.

Several among the most elegant inkstands, are in rock-crystal mounted in silver. The limp substance has been fashioned for that

"ABOUT A HOOP OF GOLD, A PALTRY RING THAT SHE DID GIVE ME."—SHAKESPEARE.

HILDRETH MANUFACTURING COMPANY,

53 MAIDEN LANE, NEW YORK.

PLAIN SOLID GOLD RINGS AT LOWER PRICES THAN YOU ARE PAYING. SEND FOR SAMPLES. QUALITY GUARANTEED.

KENDRICK & DAVIS,

LEBANON, N. H.

MANUFACTURERS OF THE

Standard Dust Proof Watch Key.



After this date all Keys of this Style will have number stamped on each Key.

FOR SALE BY THE TRADE.

purpose in many different ways. Some of these inkstands represent a pasha in the usual crouching attitude; some exhibit a Turkish beauty reclining on cushions, with her head resting on her right hand.

The illustration reproduces a trophy in fine



gold, consisting of palms and olive branches, modelled by Meissonier and chased by Bapst & Falize's best workman. It is applied on the top cover of a book, which was offered a few days ago to President Carnot.



A Lady's Ramble Among the Jewelers.

Both lizards and toads are reproduced in gem jewelry.

The Renaissance scroll design appears in some of the new clock cases.

Bonbon dishes come now in enameled silver, representing a leaf or a flower.

The prayer books with their silver-mounted covers are a feature of the church weddings now.

Jewel boxes with silver decorations, faithfully copy the old brass caskets in the Nuremberg Museum.

A favorite brooch at the present time consists of a large opal set in a framework of brilliants or diamonds.

Numbered with quite new Queen chains, is one from which depends three tiny chains, each ending with a small enameled locket.

Small earrings, composed of a single emerald, a turquoise or a sapphire, surrounded by tiny diamonds, are fashionable.

A novelty in menu stands is a little silver easel in which a tiny china slate rests. This

china slate is movable and can be cleaned as required.

Locketts are assuming their old time importance, now that the fad for miniature portraits of one's friends, painted on ivory, is being indulged in.

The very newest things in prayer books, are the ones with tortoise-shell covers, the values of which are enhanced by applied decorations in gold.

House furnishing is becoming an exacting art, and silversmiths find that each year increases the demand for articles to meet an educated taste.

Finger rings, designed especially for children's wear, afford a pleasing variety, there being gold wire, knot, twist, chased and forget-me-not bands.

Ladies incline more and more to the wearing of an elaborate ring on the little finger. One sees on this finger clusters and marquise rings, as well as those set with a fine solitaire.

Quaint little flower bowls are of engraved silver, from the sides of which spring small tubes, sometimes as many as five appearing in one bowl. When the tubes are filled with flowers the effect is very pleasing.

Some charming effects are seen in oxidized silver jewelry set with carbuncles, topazes, aqua-marines and others of the semi-precious stones. A gem of its kind is a small silver-mounted decanter beautifully cut in old Venetian style.

ELSIE BEE.

TO THE WATCH-RE-PAIR-HER.

When any Watch Tool Dealer tells you that ANY lathe is BETTER than the WEBSTER-WHITCOMB, ask for references from HIM and from US.

We have sold 6,402 lathes, and can give you references in all parts of the world.

If he says it is CHEAPER, remember the higher priced tool *may be* the cheaper—99 times out of 100 it is the cheapest AVOID IMITATIONS. We never knew an imitator to improve on the original.



Consider this problem:—

Webster-Whitcomb Lathe.....	\$40.00
Whitcomb Lathe.....	30.00

Difference, - \$10.00

20 per cent. interest on difference is	\$2.00	per year.
12 Months in a year is	.166	" month.
30 Days in a month is	.0055	" day.
24 Hours in a day is	.0002	" hour.

This is all it costs for you to STAND UP and say "I HAVE THE BEST."

Apply this calculation to *imitations*.

With every lathe we send the following guarantee:—

"This certifies that the lathe marked 'American Watch Tool Co., No. —' was made by us from the best materials, on the most approved plan, and is a reliable lathe. For any defect in material or workmanship we hold ourselves responsible. Notify us promptly of any faults.

Waltham, ———

AMERICAN WATCH TOOL CO.

By———"

This guarantee is also signed by the inspector who has the final inspection of the work. For several years past we have tied upon every lathe a tag of caution and instruction. All purchasers are requested to demand these documents with the lathes they buy. Our address is unchanged.

AMERICAN WATCH TOOL CO.,

STONY BATTER WORKS,

In the birth-place of the American Watch Industry, which is WALTHAM, MASS.

WASHBURN & MOEN MFG. CO.,
WORCESTER, MASS.

Every Variety of Wire for all Purposes.

Manufacturers of FINE WATCH MAINSPRINGS for American, Swiss and English Watches, which for Toughness, Elasticity and Finish, are Unequaled.

Eye-Glass Springs, Clock Springs

N. Y. WAREHOUSE: CHICAGO WAREHOUSE:
 16 Cliff Street. 107 to 109 Lake St.

J. R. WOOD & SONS,



PLAIN SOLID GOLD RINGS,

Also Engraved, Chased, and Silver Rings. No goods stamped different from quality.

14 JOHN STREET, NEW YORK.

PRICE LIST.

18 K	.87	14 K Flat Engraved,	.87
14 "	.71	10 K "	.67
10 "	.55	14 K Half Round Chased,	.73

Old Gold and Silver received and estimated on; if amount allowed does not give satisfaction, notify at once and will return at our expense, in same condition as received.

JEANNOT & SHIEBLER

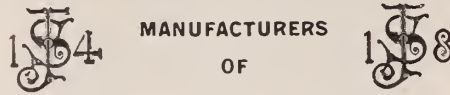

Fine Gold Watch Cases.

No. 20 MAIDEN LANE,

New York.

Constantly on hand, 14k. and 18k. Cases to fit any Movements in the Market.

GEO. W. SHIEBLER,
SILVERSMITH.



Artistic Novelties.

HOLLOW AND FLAT WARE.

Sterling Silver

No. 8 Liberty Place,

NEW YORK.

EZRA KELLEY'S

Famous Watch, Clock and Chronometer Oils,

RECEIVED AT THE EXHIBITION UNIVERSELLE, PARIS, 1889,

The only Award of Merit given to Manufacturers of American Oils

It is to the interest of every Watchmaker to use in his work the *Best Oil* obtainable, regardless of cost. Mr. Kelley's claim to be the foremost manufacturer of Oils, giving the best results, is not based upon his own assertion, but is founded upon the fact that wherever his Oils have been exhibited in competition with other makes, subject to an examination of experts, they have received the highest *Award of Merit*. For sale by all the Leading Jobbing Houses.

HENRY GINNEL & CO.,

GRIMSHAW & BAXTER, EUROPEAN AGENTS,
 35 GOSWELL ROAD, LONDON, ENGLAND.

GENERAL AGENTS,
 31 Maiden Lane, NEW YORK

A Wonderful TOOL FOR THE BENCH.

Instantaneous in Its Work.

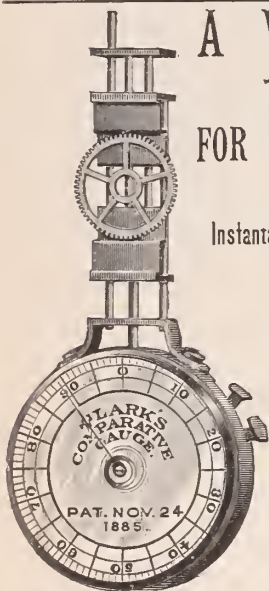

Dividing the inch into one thousand parts. A most practical tool for watchmakers for gauging from a hair-spring to a main-spring. Non-comparable for a height and depth gauge. Instantaneous for hair-spring work.

For sale by all Jobbers.

NORDMAN BROTHERS,
 120 Sutter St., SAN FRANCISCO, CAL.
 Sole Agents for the United States.



THE ORIGINAL **GOLD CROWN FILLED RINGS.**



To meet the demand for a lower priced Gold-Filled Ring, we are now making, in connection with the Crown Ring a Second Quality Ring, stamped as above. WE MANUFACTURE FOR THE JOBBING TRADE ONLY. **WM. E. McCALL,** Successor to McCall & Newman, 625 Arch Street, Philadelphia.

RUSSELL HOUSE,
 DETROIT, MICH.

Always a Favorite of the Jewelers, for the following (three) reasons:

- 1st—Excellence of its cuisine.
- 2d—Its central location to the trade they visit.
- 3d—Ample security its spacious vaults offer for samples and valuables.

CHITTENDEN & McCREARY, Prop'rs

F&B Stamped on our cards or tags means that the goods are made to give satisfaction.

FOSTER & BAILEY,
 PROVIDENCE, R. I.

TO WATCHMAKERS.—We have on hand a number of

Chronometers, by various good makers, not new, which have been in service for purposes of navigation, and are excellent instruments. They come to us by reason of the great decline in American shipping. They have been put in perfect repair, and will give satisfactory results as to performance. We will sell these chronometers at low prices, either for cash, or on accommodating terms to suit special cases, or will hire them at moderate rates, and allow the hire to apply on purchase. Send for Circular giving prices and terms.

Our Watchmakers' Transits are readily set in position. Printed instructions, easily understood, accompany each instrument, and no preliminary calculations are required. With them correct time can be obtained within one second.

JOHN BLISS & CO.

Manufacturers of Marine Chronometers,
 128 Front Street, New York.

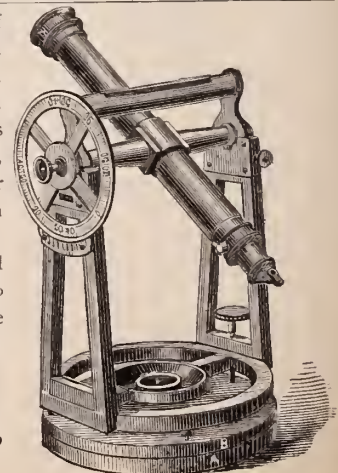
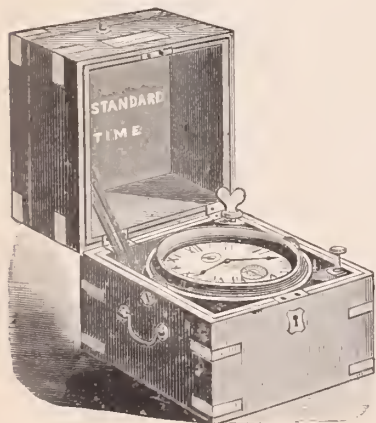

News Gleanings.

J. Rogers, Leitchfield, Ky., has sold out.
 J. McCaw has moved from Yuba City, Cal.
 E. S. Crain, Farmington, Wash., has sold out.
 E. Munson has opened a store at Mendota, Ill.
 A. Cording, Saunemin, Ill., is out of business.
 J. I. Stephens, Pensacola, Fla., is out of business.
 A. W. Hawver, Sharon, Wis., is out of business.
 J. J. Alexander, Nanticoke, Pa., is out of business.
 C. Stoll & Co., Mokena, Ill., are going out of business.
 T. E. Pritchard has gone out of business at Onarga, Ill.
 A. E. Hall has succeeded Hall & Freeman at Preston, Minn.
 M. Barborka is no longer located at 466 Broadway, Troy, N. Y.
 H. Buck has moved from Pukwana, S. D., to Garretson, same State.
 A. F. Thompson has succeeded Graham & Thompson, at Adel, Ia.
 La Grange & Meissner, Reinbeck, Ia., have sold out to E. C. Meissner.
 S. C. Scantlebury has moved from Eastport, Me., to Woburn, Mass.
 J. C. Hawsworth has moved from Keyport, N. J., to Cambridge, Md.
 H. S. Murphy has moved from North Manchester, Ind., to Wheeling, W. Va.
 J. K. Galbrath has moved from Garden City, Wis., to Adrain, same State.
 F. L. Fowler has bought out the business of W. W. Lombard, Island Pond, Vt.
 H. Y. Burlingham has moved from Hartwick, N. Y., to Sherburne, same State.
 C. B. Abercrombie, Denver, Col., has moved from 610 16th St. to 324 15th St.
 Frank Erwin and W. H. Shannon, Great Falls, Mon., have gone out of business.
 A. F. Haberl and C. D. Ledger, Denver, Col., have moved from 1704 to 1658 Lawrence St.
 P. A. Gardner, Spartanburg, S. C., has sold out his jewelry and dry goods stores to W. J. Hill.
 Max Olenick, Minneapolis, Minn., has moved from 117 Nicollet Ave. to 533 Guaranty Building.
 At Elmwood, Ill., S. R. Quigley has succeeded E. R. Brown & Son, and E. E. Gabriel has succeeded W. T. Sloan & Co.
 J. M. Bacon, South Framingham, Mass., whose business was recently burnt out is selling off his damaged stock at half price.
 The plate glass window of A. R. Vaughan's store, Pawtucket, R. I., was smashed last week by a wagon backed into it by a frightened horse. The loss was \$70; insured.

ESTABLISHED 50 YEARS.
RANDEL, BAREMORE & BILLINGS,
 IMPORTERS OF
DIAMONDS,
 AND OTHER PRECIOUS STONES.
 FINE PEARLS A SPECIALTY.
 MANUFACTURERS OF
DIAMOND JEWELRY,
 IN THE LATEST DESIGNS.

Diamonds Recut in Modern Styles or Repaired on Premises.

58 Nassau Street,
 29 Maiden Lane,
NEW YORK.

1 Tulp Straat,
AMSTERDAM.

1 St. Andrews St.,
 Holborn Circus.
LONDON, E. C.

LARTER, ELCOX & CO.

MANUFACTURERS OF

THE SPRING BACK STUD.



Send for Selection Package of Studs.

Snake Rings.

GENTLEMEN'S

WHITE · ONYX · JEWELRY.

LADIES' RINGS.

Gentlemen's Rings.

FACTORY, NEWARK, N. J. + + OFFICE, 41 & 43 MAIDEN LANE, N. Y.

A. J. GROENMAN & CO.,
DIAMOND CUTTERS,
 80 NASSAU ST., N. Y.
WE MAKE A SPECIALTY OF SEL-
ING FINE, SMALL MELEES.

ESTABLISHED 1850.
WILLIAM PARK,
Stone Seal Engraver,
 Arms, Crests in the highest style of Art. Also Gold Rings, Silver Seals, Brass and Steel Seals engraved SUPERIOR to Stone Seal engraving. Dies cut for Envelope Stamping in best Style.
 26 JOHN STREET, N. Y.

FACTORY,
 ST. IMIER, SUISSE.

HIPP DIDISHEIM,

83 NASSAU STREET,
 NEW YORK.

IMPORTER OF WATCHES,

SPECIALTIES:

The "**Nassau**," the best imported movement in the market, fitting all American cases.
 The "**Mignon**," the best Chatelaine Watch for the money.
 The "**Gem**," a high grade Chatelaine Watch with second hand, gold crown jewels in extra settings, etc.

If your jobber don't keep these goods, send to us and we will send you the address of one who does.

ARE YOU DISSOLVING PARTNERSHIP
 ARE YOU HAVING DULL TRADE
 ARE YOU ABOUT TO RETIRE
 ARE YOU OVERSTOCKED
 ARE YOU REMOVING

IF YOU ARE, COMMUNICATE WITH

A. J. COMRIE,
 AUCTIONEER,

Specialty of Jewelers' Sales. 16 West 125th St., New York.



Geneva Optical Co.,
 MANUFACTURERS OF
 Spectacles, Eye
 Glasses, Lenses
 and Cases.
 23 WASHINGTON ST.,
 CHICAGO.

The Highest Grade
 — OF —
Electro Silver
Plated Ware

Is Stamped with the
 **ROGERS TRADE-MARKS.**
 MANUFACTURED BY
The Wm. Rogers Manufacturing Co.,
 P. O. DRAWER 30,
 HARTFORD, - CONN.

UNITED · STATES · OPTICAL · CO
 15 Grand River Ave., Detroit, Mich.
 MANUFACTURERS AND JOBBERS OF
SPECTACLES and EYE GLASSES.

Special Attention given to Prescription Work, and Repairing by Skilled Workmen.

Our facilities for the manufacture of SPECTACLE and EYE GLASS CASES are such that we can quote lowest prices.

WILL FURNISH SAMPLES ON APPLICATION.

H. Michaels, Jonesboro, Ark., died suddenly some days ago.

G. H. England, Holyoke, Mass., has thoroughly remodeled his store.

J. R. Heath, Placerville, Cal., has opened a branch store at Georgetown, same State.

An addition to the factory of the Westfield Plate Co., Westfield, Mass., is contemplated.

Smythe & Lawrence will soon open a fine new store at Elgin, Ill. A. M. Smythe is a well known jeweler on the west side of that town.

A jewelry manufactory will shortly be established at Fort Worth, Tex. W. C. Pfaeffle, of that city, is interested in the enterprise.

G. W. Phipps and G. W. Taylor, who recently formed a partnership at Salisbury, Md., have opened on the first floor of the Evans building in that town.

Since S. B. Strunk, Byside Bath, Pa., has been appointed excise agent, the village is minus a jeweler. The people are desirous of having one in their midst.

R. L. Wells, who opened a little repair shop three years ago at Sprague, Wash., has now one of the largest jewelry enterprises in the new State. He has recently leased a large building.

William Graeff was arrested last week, at Lebanon, Pa., for carrying concealed a large knife. When arrested he was trying to sell to jeweler H. L. Kohler four gold rings. He was later discharged for want of evidence.

J. H. Stevenson, assignee of W. B. Hatton, Williamsport, Ind., has sold out the entire establishment to E. A. Beggs, who will add the stock to his own jewelry business and continue at his old stand. The purchase price was \$550.50.

A serious fire was narrowly averted in the store of E. E. Bates, Palmyra, N. Y., last Sunday night. The oil in the night lamp caught fire and was blazing furiously, when a passer-by kicked in the door and threw the lamp into the street.

C. Rieck, Utica, Neb., had several attachments placed on his stock during the past week. The creditors claim that he has been disposing of his goods with the intention of leaving the country. Mr. Rieck asserts that he has no intention of so doing.

An Elgin, Ill., Land and Improvement Company advertise that the Elgin Watch Case Co. are now employing 200 hands and are arranging to employ 400 at the earliest possible moment. They also say that there is reason to believe that the number will be 800 within five years.

At Lowell, Mass., Albert J. Dupont was arrested early Sunday morning by Detectives Hayes and La Flamme, charged with breaking into Potter's jewelry store, and other stores. Dupont, who is only 22 years of age, admits having committed the burglaries. At one time he was night porter in the American House in that city. All of the burglaries have been committed within a couple of months.

M. Abraham, 515 Fulton St., Brooklyn, N. Y., is advertising a closing-out sale.

T. L. Rogg, Des Moines, Ia., is conducting a clearance sale.

About \$1,000 a week is the pay-roll of the Aurora watch factory.

O. E. Ashbrook, Winchester, Ky., is selling off his stock at auction.

Harry Wade, Lafayette, Ind., visited Indianapolis last week.

Morrison & Co., Portland, Me., made an assignment last Thursday.

It is now settled that the Manhattan Silver Plate Co. will retain their factory at Lyons, N. Y.

J. L. Bliss, Atchison, Kan., celebrated his twenty five years' residence in that city last week.

I. N. Clawson, Watkins, N. Y., will move his store to the Jefferson House annex, this week.

Frank Chase, a practical watchmaker from Brighton, Ont., has opened a shop in Caledonia, N. Y.

E. V. & C. T. Saul, Waltham, Mass., have removed to their elegant new store in Lincoln's Block.

It is reported that large quantities of diamonds have been discovered in North Lapland, Russia.

Burglars broke into Mernin's music and jewelry store, La Vegas, N. M., recently, and stole goods valued at \$100.

Simons Bros., Columbus, O., have almost entirely sold out, and are now actively engaged in the real estate business.

William Berndt, Milwaukee, Wis., has been succeeded by the Berndt & Speck Co., Inc., with a capital stock of \$20,000.

Charles E. Derleth, who moved recently to East St., Louis, Mo., has sold out his business at Greenville, Ill., to C. H. Riedeman.

Hon. J. B. Wickersham, formerly president of the Lancaster Watch Co., Lancaster, Pa., died very suddenly in that city on Wednesday, age 60 years.

John Meyer, has sold out his business at Loogootee, Ind., and has bought a lot in Elwood, same State, on which he will erect a handsome jewelry store.

Indianapolis, Ind., jobbers received word last week of the failure of J. H. Vada-kin, Bethany, Ill. Baldwin, Miller & Co., are creditors for a small amount.

The jewelry store of Daniel Gilbert, Carbon Hill, Ala., was recently burned out, incurring a loss of between \$500 and \$1,000. There is said to be no insurance.

W. W. Fisher, Watsonstown, Pa., has bought out the store of M. J. Beckley, of Sunbury, same State. Mr. Beckley proposes to move to Harrisburg and retire from the trade for the present.

Col. J. M. Rutherford, the jewelers' auctioneer, has been indisposed for several weeks and two sales for which he had been engaged had to be postponed. He began on Monday an auction sale at Watsonstown, Pa., for W.

W. Fisher. At the conclusion of this sale he will hold another for Mr. Fisher at Sunbury, same State.

Hop Sing, a Chinese laundryman, was last week arrested at Knoxville, Tenn., for stealing jewelry. He would go into a jewelry store, and ask to see some article. While examining jewelry, he always managed to hide something and carry it off.

A cross-petition was filed last week at Canton, O., in the partition case of C. D. Rood vs. Howard Douglass, as assignee for J. C. Dueber. The petition asserts that Mr. Dueber has now had his interests again placed in his hands, and it asks that the Sprinkle farm held by him and Mr. Rood be divided.

The gold medal awarded to the State of Iowa, for superiority in educational exhibit at the Paris Exposition has been received by State Superintendent Sabin. The medal is an elegantly-finished circle of gold, a quarter of an inch thick, and three inches in diameter. Upon one side appear in relief the figures of a man and woman, the former receiving a crown from the other, and the words "*Exposition Universelle*"; on the other side of the medal is the figure of a man and the words "*Republique Francaise; Etat D'Iowa, Department de L'Instruction Publique.*" It is the finest thing of the kind ever awarded to the State.

He Loved the Race Track.

ST. LOUIS, Mo., March 26.—G. Ramming Harris, formerly collector for the Dennison Mfg. Co., of 404 N. Third St., was arrested last night and lodged in jail on a warrant charging him with having embezzled \$300 from that firm. His downfall is attributed to gambling on horses.

The warrant was issued yesterday morning by Assistant Prosecuting-Attorney Estep, on information sworn to by W. D. Franklin, manager of the house. Mr. Franklin claimed that the shortage extends over a period of a month, beginning about the 1st of December, and that such small amounts were taken at times that the money was not missed. He said that on January 4 their eyes were opened to the fact that something was wrong by the disappearance of Harris under mysterious circumstances. An investigation disclosed the condition of affairs, and a search was made for Harris but he could not be found.

A Popular Western Jeweler Expires.

DAVENPORT, Ia., March. 26—C. W. Smith, was about two weeks ago suddenly ill with aphasia, an affection of the brain which makes speech unintelligible though the other faculties are unimpaired. Days elapsed and his condition did not improve perceptibly. Yesterday morning he was taken suddenly worse and shortly after twelve o'clock he died.

Mr. Smith was a resident of this city for many years. He was well-known in musi-

cal circles, having been one of the founders of the choral society which flourished years ago and for many years, and until his sickness came upon him, a member of the Apollo quartette and the Second Presbyterian church choir. He was one of the charter members of the calvary company formed here years ago and of the Governor's Greys and was once Commander of the Uniformed Division, Knights of Pythias. The funeral will undoubtedly be under the auspices of the order. The deceased was a man of many excellent traits of character, candid and straightforward in all his dealings, and was held in high esteem. He was in his 47th year.

A Jewelers' Box Manufacturer Burnt Out.

Two fires broke almost simultaneously in Nos. 120 and 122 Fulton St., New York, at 9:30 p. m., Monday. The latter is a six-story building. The upper floors of the building are partly occupied by Ludwig Lehmann, manufacturer of jewelers' paper boxes.

The flames were carried to the upper stories through a shaft at the rear of the building, and soon reached the roof. The fire gained such headway that the building was practically gutted, and everything in the building consumed. By 10:30 the fire was put out, but by that time little more than the walls were left standing. The total loss in No. 122 is estimated at \$20,000.

Chicago.

J. Michaels has engaged with Giles, Bro. & Co., to represent them in the West and Northwest.

On the 24th the Secretary of State approved the increase of the capital of the Geneva Optical Co. from \$50,000 to \$100,000.

S. E. Settle, of S. E. Fisher & Co., and M. Lambert, of H. Zimmern & Co., New York, and A. J. Mockridge, Newark, N. J., were in the city last week.

H. H. Walton, manager of the branch of the Meriden Silver Plate Co. at 133 Wabash Ave., has just returned from the East, having visited the headquarters of his company. He says that Manager Curtis expressed himself as highly pleased at the condition of the Chicago agency.

The regular meeting of Jewelers' Council No. 316 N. U., was held last Monday evening in Liberty Hall, 70 Adams St. Dr. G. N. West, presided, and twenty members were in attendance. Three applications for membership were presented, and one candidate, G. E. Payson, was admitted to full membership. The next meeting will take place April 13th.

The J. F. Kitchell Mfg. Co. have been re-organized at Newark, N. J., with J. B. Mayo, as half owner of the stock. The new Company, which will be known as The Kitchell, Mayo Mfg. Co., is located at 73 Hamilton St. They will do a yearly business of \$50,000.

SOUVENIR



SPOONS

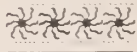

... OF ...

WASHINGTON, D. C.

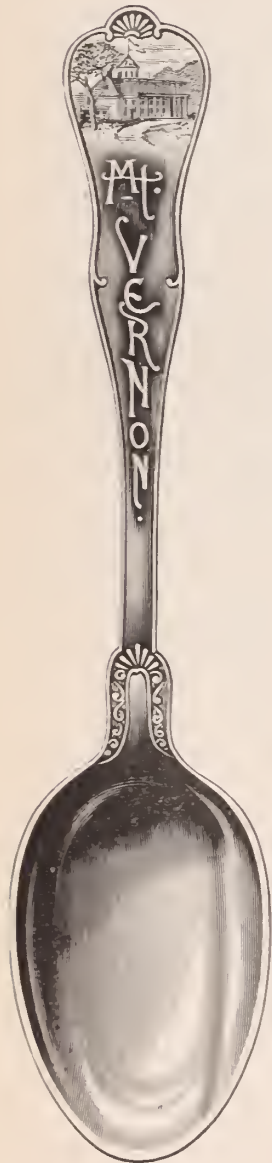

The National, * *
 The White House,
 * The Mt. Vernon,

Of interest to everybody.

Salable Everywhere.

Moderate in Price.

Original in Design.

MADE IN

TEA AND ORANGE SIZES.



PRICES TO THE TRADE.

- The National, \$2.25, retails for - \$3.00
- The White House and Mt. Vernon
 Teas, - - - - \$1.60, \$2.00
- The White House and Mt. Vernon
 Orange, plain, - - \$1.90, \$2.25
- The White House and Mt. Vernon
 Orange, Gilt bowl, \$2.12½, \$2.50



HARRIS & SHAFER,

1113 PENNSYLVANIA AVE.,

WASHINGTON, D. C.

The Receiver of the McBride & Marcellus Co. Removed.

CLEVELAND, O., March 26.—Sheriff Ryan and D. H. McBride have received notice to appear in Court, and show cause why they should not be attached for contempt of court for having taken possession of the stock of the McBride & Marcellus Co. after a receiver had been placed in charge. The proceeding was begun by Receiver O. J. Campbell.

Judge Noble, yesterday morning, decided the motion to continue the receiver of the company adversely to the receiver and refused to continue him. In Judge Noble's opinion Receiver Campbell was not properly appointed and qualified for the reason that when he was named by Judge Sherwood he did not have a case in court on which to base his appointment. In other words, Judge Noble's ruling was that a case is not in court until it is docketed and summons issued.

Mr. Campbell was appointed by Judge Sherwood, conditionally on his giving a bond in \$50,000. The motions to remove the receiver are now unnecessary, and the assignee will probably take charge, subject to judgment note lien, unless the Marcellus faction makes some new move.

D. H. McBride, C. E. Marcellus and L. P. Smith were sued by Attorney L. A. Russell in the court of common pleas yesterday for \$717.60 and interest from Dec. 3, 1890, at 6 per cent. The action is begun on a promissory note made payable to J. P. McKearney and by him assigned to Mr. Russell. The note was executed Dec. 3, 1887, and made payable in three years.

Mr. Russell swore to an affidavit, an attachment which accompanied the petition, and to the effect that C. E. Marcellus is about to remove his property, or a part of it, beyond the jurisdiction of the court in order to defraud his creditors; and that he is about to convert his property into money and place it beyond reach. On the strength of the affidavit an order was issued to attach sixty feet of property, owned by Mr. Marcellus.

The Chicago W. & J. Co. in Trouble at Newark, N. J.

NEWARK, N. J., March 26.—Complaint has been made that violations of the lottery law are being committed by those who claim to be doing a legitimate watch club business, but who are really holding weekly lotteries, in which the capital prize is a watch. The operators attracting special attention address the people under the title of the Chicago Watch & Jewelry Company, which has been exposed in other cities. The company has opened an office in the second floor of 224 Market St. The operations of the concern are the same as those exposed by Anthony Comstock in New York, as recently published in THE CIRCULAR. Behind the counter is the Newark agent, A. S. Ford, of Rahway.

The excuse offered by the operators in such enterprises in this city is that others do it, and recently the Prosecutor had his attention called to the fact by a man, who

accused a prominent jeweler of selling watches on the straight-out lottery-plan. The Prosecutors said that it was undoubtedly an infraction of the lottery law, but he could do nothing because his informant refused to make a complaint.

Held Up in His Own Store.

KANKAKEE, Ill., March 25.—Two men entered the store of C. P. Townsend last evening, and one of them, pointing a revolver at the jeweler's head, ordered him to turn over the watches in his showcase. Mr. Townsend did so, and then they demanded and received his own watch.

The burglars then backed from the store, keeping him covered, and escaped. About \$3,200 worth of goods are said to have been taken. The store was crowded at the time of the robbery

The Missing Appears.

COLUMBUS, Ga., March 25.—William Miller, an employee of V. J. Pekor, whose mysterious disappearance caused a sensation last week, has been ferreted out at the Vernon hotel, and the sensation is over. Miller could give no account of himself after leaving his boarding-house last Monday morning, and told his employer to-day that he was subject to "spells" of insanity, which probably explains his conduct. He has not yet reported for duty.

Ruling Prices of Clocks and Watches in Europe.

WASHINGTON, D. C., March 26.—A gentleman who says he is desirous of attempting the manufacture of watch and clock dials in the United States has asked the Treasury Department to authorize the Appraisers' Department at New York to give him certain information in regard to the ruling prices of such articles in Europe. In reply, he was informed by Assistant Secretary Spaulding that such information would be contained only in the invoices of importers, and that it has always been regarded as strictly confidential.

The Gloversville Burglars Sentenced.

JOHNSTOWN, N. Y., March 28.—The trial of James, alias "Biggy" Donovan, on the charge of complicity in the famous robbery of A. D. Norton's store at Gloversville, last summer, was concluded yesterday, when the prisoner was found guilty as indicted and sentenced to six years and six months imprisonment in Dannemora Prison. His companion, Tom McAveney, will be tried May 4.

The conviction of Donovan is a victory for the Jewelers' Security Alliance, of which the officers of that association may take justifiable pride. Some time in May, 1890, the safe in Mr. Norton's store was broken into by burglars, and jewelry to the amount of \$25,000 stolen. Mr. Norton was a member of the Jewelers' Security Alliance, and at once notified that organization, with the result that within a few days after the robbery a staff

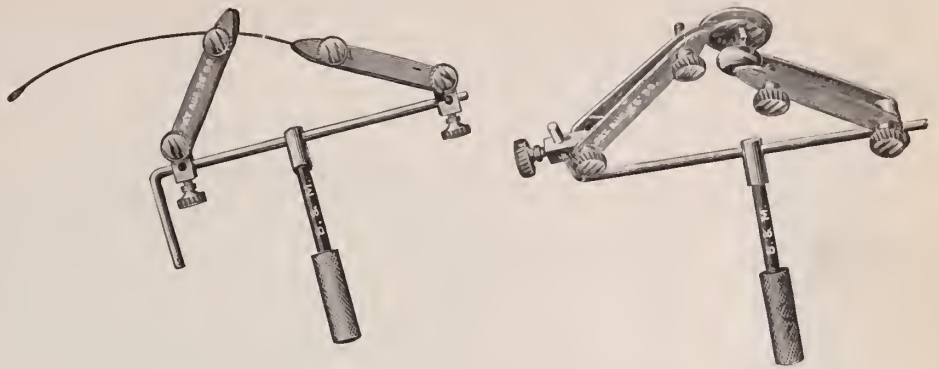

Magic Repair Clamp. Price \$1.25.

(Bowman & Musser, Sole Agents.)

This is one of most useful of recent inventions. For 13 cuts showing additional uses, see March issue of "The Keystone." In the April issue of same journal, we give a list of jobbers who carry them in stock.

Ask your jobber to show you them, or if he does not have them or will not get them for you, send \$1.25 to us and we will send you a set, postage paid.

Bowman & Musser,

Importers and Jobbers,

Watches, Chains, Spectacles, Tools and Materials,

Lancaster, Pa.

SOUVENIR * WATCH

*** * SPOON. * ***

(Patented.)

Particularly Adapted to the Watch Trade.

Name of any city or town can be etched in the bowl.

We have a large assortment of sterling silver souvenir spoons to which we are constantly adding new designs. Send for samples.

HENRY T. SPEAR & SON,

Wholesale Dealers in

American Watches and Silver Plated Ware,

370 WASHINGTON ST.,

BOSTON,

MASS.

JAMES P. SNOW.

ESTABLISHED 1834.

CHAS. E. WESTCOTT

SNOW & WESTCOTT,

SUCCESSORS TO G. & S. OWEN & CO.

MAKERS OF

FINE JEWELRY,

Lace Pins, Ear Rings, Scarf Pins, Sleeve Buttons, Sash Pins, Collar Buttons, Bracelets, Studs.

All Goods sold by us are exclusively of our own manufacture and are warranted 14 K. Fine, and stamped as such when possible.

No. 3 MAIDEN LANE, NEW YORK.

* * THE * *

DEXTER SPOON.

SOUVENIR
OF
Newburyport,
MADE IN
TEA,
ORANGE
AND
**SUGAR *
* SPOONS,**
IN
STERLING SILVER
ONLY,

And Good Weight.

Trade supplied with the goods in any quantities, also with copies of Dexter's famous book:

"A Pickle for the Knowing Ones."

New England orders should be sent to

William P. Jones,
Newburyport, Mass.

Orders from all other parts of the United States and Canada will be filled by

DEXTER TEA SPOON.

Towle Mfg. Co.,
Newburyport, Mass.

AND

149-151 State St., **CHICAGO.**

E. R. STOCKWELL,

19 John Street, **New York.**

All descriptions of

BADGES, * MEDALS, * PINS,
For Colleges, Schools and
all Societies,
IN SILVER AND GOLD.

Jobbing and Repairing for the Trade.

of Pinkerton detectives were detailed to bring the thieves to justice. Without one dollar of expense to Mr. Norton, nearly all the jewelry was recovered. Two men whom the detectives knew were implicated in the burglary, but they could not be convicted on that charge owing to the lack of evidence. They were detected in cracking the safe of a grocery store at Utica, and owing to the efforts of the Alliance officers are now serving terms of imprisonment at Sing Sing. When Donovan was being taken to jail it is stated that he said: "If I had known that Norton was a member of the Jewelers' Alliance I would have never tackled the job."

Jeweler Watercott Had No Safe, Etc.

PEORIA, Ill., March 25.—The little city of Henry, a few miles from here, up the river was the scene of a heavy robbery during Tuesday night. Some time during the night an entrance was effected into the jewelry store of J. Watercott, the burglars entering through a window which they raised.

Mr. Watercott had no safe as he had no fear of thieves. It has been his custom for a long time back to leave the stock in the show case. Tuesday night was no exception, so it was an easy matter for the thieves to carry away \$1,500 worth of gold and silver watches. The matter has been reported to the police here, but so far no clue has developed. It is probable the thieves went straight to Chicago.

The Cleveland Would-be Thieves in Court.

CLEVELAND, O., March 28.—The cases of the three suspects arrested last week in the act of robbing A. D. Ernie & Co.'s store, came up for trial Wednesday morning. John Harris entered a plea of guilty to the charge of being a suspicious person. His having been recognized as one of the trio who robbed Wilsdorf's jewelry store, 1115 Lorain St., last November appears to have discouraged him. His sentence was deferred until April 1.

"Blinky" Mike Coleman, to-day changed his plea of not guilty to one of guilty, and received a sentence of three months and a fine of \$50 for suspicion, and the costs, and thirty days for carrying concealed weapons. Thomas Fox, on hearing the penalty visited upon his confederate, prayed for more time to establish a reputation. He later entered a plea of guilty of suspicion and received the limit—\$50, costs and thirty days.

Journeymen Watch Case Makers Organize.

BROOKLYN, N. Y., March 30.—Several hundred watch case makers from New York, New Jersey and this city, met last Saturday evening at 315 Washington St., for the purpose of effecting an organization, and to listen to a lecture delivered by T. B. Maguire. In the course of his remarks the latter said that seven years ago, he had the pleasure of attending the meeting of the

watch case makers in New York and learned that while their wages were decreasing, the profits of the employers were increasing. The common hod carriers were paid more wages than the watch case makers, but there was a time when the latter carried a gold headed cane, but they can't do that at present on \$8 a week. He appealed to his listeners not to cringe or fawn, and not to offend their bosses, saying that a tyrant never made a slave, but the latter always made the former. There was no need of strikes if they would meet their bosses like men.

Another meeting will be held shortly.

An Offer of Seventy-five Cents Being Accepted.

PROVIDENCE, R. I., March 27.—Notwithstanding the tangled condition of the affairs of Towne & Ingraham, of this city, as related in THE CIRCULAR, the receiver, P. F. Parsons, has succeeded in so straightening out matters as to be able to form an idea of the firm's standing.

Mr. Towne, who is anxious to effect a settlement of the liabilities, has, during the past week, made a compromise offer of 75 cents on the dollar, which is being generally accepted by the creditors, most of whom are Providence concerns.

Stephen J. Marden Dead.

Stephen J. Marden died at his home, 370 Livingston St., Brooklyn, on Monday, in his 63d year. For thirty-five years he was a manufacturer of jewelry and masonic charms at 34 Park row, New York.

The deceased was well known in masonic circles. Pneumonia was the cause of death.

The Week's Arrivals.

The following dealers from out of town were registered in N. Y. during the current week: Henry Birks, Montreal, Can.; Jas. Allan, Charleston, S. C.; Tremont H.; F. A. Knowlton, Worcester, Mass.; Astor H.; Henry Kohn, Hartford, Conn.; Normandie H.; Geo. Gay, buyer for Brown, Thompson & Co., Hartford, Conn., 120 Franklin St.; C. F. Mathey, St. Louis, Mo.; R. H. Galbraith, Cincinnati, O.; Imperial H.; S. Frankel, Toronto, Can.; Astor H.; R. Harris, Washington, D. C.; St. Denis H.; G. H. Ford, New Haven, Conn.; St. James H.; G. G. Tress, Columbus, Ga.; St. Denis H.; G. W. Williams, Cleveland, O., buyer for E. H. McGillan & Co., 355 B'dway.; Julius Watercott, Henry, Ill.; Grand Central H.; Mr. Hansell, Hartford, Conn.; E. C. Lawrence, Boston, Mass.; Astor H.; J. C. Phillips, Chicago, Ill.; Sweeney's H.; T. Jarecki, Erie, Pa.; Hoffman H.; J. G. Myers, Albany, N. Y.; Continental H.; A. Kahn, Norton, Pa.; H. A. Harrington, Boston, Mass.; Hoffman, H.; H. W. Richards, Boston, Mass.; St. James H.; J. T. Sherman, Boston, Mass.; Murray Hill H.; A. M. Barnum, Buffalo, N. Y.; Imperial H.; J. C. Chandler, Cleveland, O.; Westminster H.; S. F. Merritt, Springfield, Mass.; Astor H.

SOUVENIR SPOONS.



In answer to the fashion for such mementos, we have produced a large variety of unique and peculiar spoons, suggesting various places and events. The accompanying cuts represent the various patterns although emblematic cities are sold generally. Besides the patterns illustrated here, we have designs applicable to almost every large city in the

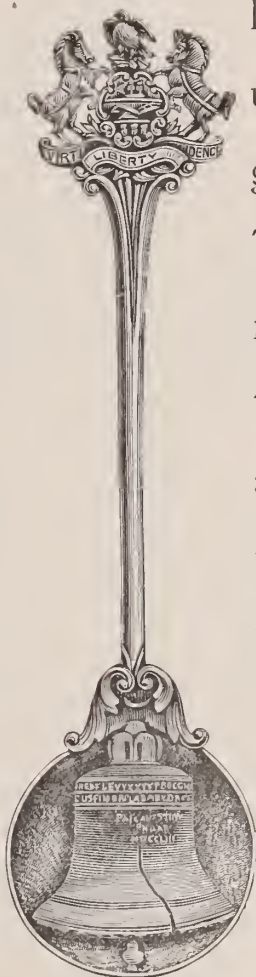

country. The accompanying patterns illustrate the designs applicable to almost every

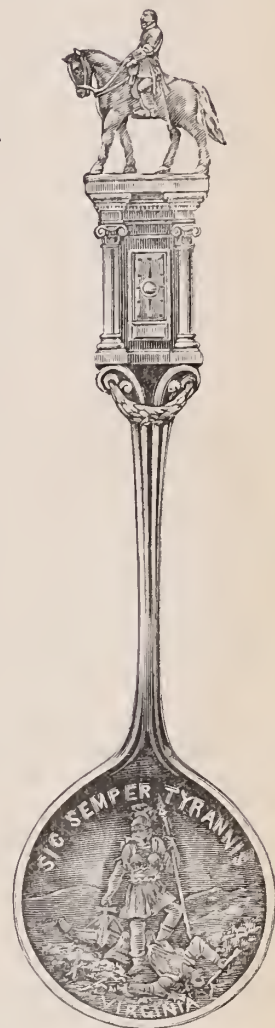

GORHAM MFG. CO.

Silversmiths,

Broadway and 19th St., New York

St. Louis.

A meeting of the stockholders of the M. Eisenstadt Jewelry Co., is called for the purpose of acting on a proposition to increase the capital stock from \$40,000 to \$60,000.

Geo. Stumpf, who has been for many years with C. Boehmer & Co., 511 Franklin Ave., will this week open a handsome new store on his own account on Franklin Ave., between Broadway and Sixth St.

The Retail Jewelers' Association met last Sunday. J. Ryser, the vice-president of the association presided, and arrangements were perfected for the excursion to Springfield, Ill., in May, on invitation of the Illinois Watch Co. H. Mauch, John Schmidt and F. H. Niehaas were appointed a committee to arrange for transportation. The committee have secured two special cars to run over the Chicago & Alton railroad, leaving St. Louis early in the morning and returning during the night. A committee consisting of Jule Schmitt, John Henckler and H. Mauch were appointed to draft by-laws and constitution.

Norfolk, Va.

W. F. Lintz & Co., 187 Main St., recently bought several hundred old muskets.

George H. Norwood, with Chapman & Gale, returned last week from Currituck Sound.

J. J. Johnston, 29 Granby St., has commenced a sixty days' closing-out sale of one thousand silver sets.

Chapman & Jakeman have presented to the ladies in charge of the Catholic Fair, being held in this city, a very handsome prize cane.

S. R. Smith contemplates extensive improvements in the near future. Geo. Smith, connected with this house, left this week for New York.

A. K. Sloan of Carter, Sloan & Co., New York, and family, were in this city last week, having just returned from a pleasure trip to Virginia Beach.

Mr. Chapman, of Chapman & Jakeman, who has just returned from a southern trip, has gone North to lay in a stock of spring and summer goods.

Detroit.

R. J. Dewey, for nine years past with the house of F. G. Smith, Sons & Co., last week completed his labors in the interest of that firm. Mr. Dewey has received and accepted an offer of a position with the Parisian house of Spaulding & Co., Chicago, Ill. He will sail about April 6. The firm and his associates in the house gave him very handsome presents.

Wright, Kay & Co. have secured a lease of the store next to their present location at 140 Woodward Ave., to take effect May 1, 1892. The store is the one now occupied by L. Black & Co., opticians. It is the intention of Wright, Kay & Co. as soon as they obtain possession of the new store to connect it

with their present house by arches, and re-decorate and re-arrange the whole.

Syracuse.

F. H. Wells is the first jeweler in this city to get out a souvenir spoon.

I. Duncan will move from 112 W. Genesee St. to 113 W. Washington St., this week.

J. W. Pierce, of Joseph Seymour's Sons & Co., who has been on an extended Western trip in the interests of the firm, has just returned.

C. H. Phillips, diamond setter, and A. A. Monnoyer, watchmaker, with H. R. Hukins, deny the statement printed in one of THE CIRCULAR'S contemporaries, to the effect that they are about to engage in business for themselves.

Kansas City.

The auction sale of the stock of M. B. Wright & Co., has been discontinued.

The stock of goods lately held by Bart McClune will be moved to 915 Walnut St., as the building he previously occupied is to be removed.

C. O. Christl died recently at the home of his father, Joseph Christl, in Newark, N. J. He was formerly with M. B. Wright & Co., in this city, and had many friends here.

The Board of Equalization has increased the returns made to the assessor by the Jaccard Watch and Jewelry Co., F. O. Hadley, Cady & Olmstead, M. Benjamin, and H. Oppenheimer & Co.

Philadelphia.

C. E. Stringfield, West Philadelphia, is resting at Atlantic City and is rapidly recovering from a recent illness.

Considerable unpleasantness will be caused to jewelers on lower Chestnut St., in the course of widening the thoroughfare above 7th St.

Wholesale and retail jewelers alike say the business of Holy Week—ordinarily a little ahead of the average—was this year particularly dull. Tight money and bad weather were the causes.

Mr. Eaton, of H. D. Merritt & Co., and Mr. Thomas Frothingham, of Frothingham & Co., Attleboro, Mass., and George Osborne, of Wm. Smith & Co., New York, were among the trade visitors of last week.

S. M. and M. S. Friedenbergs sailed from New York to Europe on the *Spre* yesterday. The Messrs. Friedenbergs expect to remain abroad until July. S. R. Friedenbergs will have charge of the home establishment in the interim.

Among the many beautiful Easter displays in Chestnut St. windows during the week was that of Bailey, Banks & Biddle, which commanded an unusual share of attention. The small tinted curtains were covered with lace, giving a peculiarly elegant setting for the many dainty objects of jewelry, pretty bric-a-brac and holiday novelties that were arranged with exquisite taste and cleverness.

Boston.

R. E. Robbins and family have returned from the South.

Joseph Cowan is home from the South after an absence of nearly two months.

Among the buyers in town this week was the junior member of J. W. Perry & Son, Lewiston, Me.

H. F. Nichols, who has been seriously ill for two weeks, is able to be at his place of business once more.

F. B. Chase, one of Charles May's salesmen, has arranged for a pleasure trip this month to New York, Washington and Ohio.

E. H. Saxton & Co., jobbers, 58 Winter St., have opened a branch office under the management of H. B. Mason, at 918 F. St., N. W., Washington, D. C.

E. A. Cowan has arrived home from a southern tour, his pilgrimage taking him through Nashville, Macon, Charleston, Washington and other leading cities.

Salesmen in Boston this week were: Col. Stevens, of the Brooklyn Watch Case Co.; George Dougherty, of the E. Howard Watch & Clock Co. and S. Wallack, New York.

The case of the Cambridge jeweler who was held on the charge of counterfeiting, by plating five-cent pieces, came up again this week before the grand jury, from whom a report is expected to-day.

Mr. Henly, of Maltby, Henly & Co., was in the city the latter part of last week to settle up the affairs of their establishment, 383 Washington St., which has been closed since the departure in January last of B. Hawkins, formerly their agent in charge.

There was a slight fire last week Monday, in the basement of the building 409 Washington St., in which are located the jobbing firms of E. F. Wilson and Henry Cowan. The damage to these concerns, however, from smoke was very little, although at one time it was feared that the building might fall a prey to the flames.

Salesman Mack, the drummer for A. D. Cairns & Co., who pawned his samples, is now employed in an entirely different business, having been placed on probation by the court through the heroic efforts of his faithful wife, who interceded in his behalf, and energetically set to work to raise the amount necessary to make good his embezzlement. She succeeded in obtaining the money and also in securing employment for him, contingent upon his release.

The annual meeting of the stockholders of the American Watch Co. was held Thursday afternoon. Treasurer R. E. Robbins read his annual report and directors were elected as follows: E. C. Fitch, President, R. E. Robbins, Treasurer, J. V. Kettell, Irving Smith, Charles W. Fogg, B. F. Brown and B. F. Stevens' Board of Directors. P. W. Carter, was elected clerk. Mr. Stevens, the new member of the Board, is chosen to fill the vacancy caused by the resignation of P. L. Everett. He is president of the New England Mutual Life Insurance Co.

Jewelers turned out in force last Wednesday to attend a meeting at the Boston Tavern of the Monatiquot Land Association, an organization composed almost exclusively of the jobbing fraternity.

New Orleans.

Mr. Burgess, representing F. M. Whiting & Co., N. Attleboro, Mass., was in the city last week.

The stock of L. E. Tyler, doing business under the name of E. A. Tyler's Son, was sold at auction at the store, 101 Canal St., by the syndic, on Tuesday, March 31. Mr. Tyler failed in business some months ago.

The local trade is enthusiastic over the success of souvenir spoons, and several houses will soon have copyrighted designs on the market. M. Scooler, pursuing the idea, has produced and is offering sardine forks and fish knives of designs similar to his souvenir spoons. There is a large field for the spoons here, and the sales are steady and good.

San Francisco.

A. Goodenough has moved from 42 to 1321 Pacific St.

H. Myers has moved from 101 California St. to 102 Kearny St.

T. Lundy, 7 Third St., has refitted and rearranged his store. Three large show windows now attract those who pass.

Col. A. Andrews has been refitting his Diamond Palace, 221 Montgomery St., and it is now one of the leading sights for strangers who visit the city.

The firm of Borneman & Street, say that the instalment plan is constantly growing in favor in this city. They claim that the instalment plan is preferable to the "watch club" scheme.

The jewelers in this city have introduced a new and rather pretty fad. Any young man who has true regard for a woman will give her a gold ribbon bracelet, perfectly plain, save for an inscription. All of these bracelets have locks, or ought to have, and the key should be carried by the donor. Though they are sometimes engagement bracelets, they are not of necessity so. If the bracelet is used as an engagement memento, a little verse is inscribed upon the bracelet, telling the world, that two more lives have been made happy in each other's love.

Cleveland.

On Monday last the Probate Court accepted the resignation of T. H. Graham and instructed him to report on or before March 31. The Court also approved the election of R. E. Burdick as trustee and fixed his bond at \$20,000.

The watch stolen from the store of W. J. P. Riedel about a month ago was found last week at a pawn shop and J. Adams, alias Tower, who was arrested at Columbus as reported elsewhere, was accused of having stolen it.



Our line, composed of

Chain Mountings, Chains, Neck Chains, Crosses, Bead Necks, Bracelets, Bangles, Earrings, Glove Buttoners, Garters, Locketts and Charms, "Mount Hope" Buttons, Initial Scarf Pins, Bar Pins, Cuff Pins, Jersey Pins,

is of high grade rolled plate, and as a guarantee that they will wear well we stamp them **F. & B.**

Our sleeve button is the "Mount Hope" and is the best in the world.

**THE UNIVERSAL MAINSPRING,
FOR AMERICAN WATCHES.**



UNIFORM
IN
COLOR.

EXACT
IN
SIZE.

See that each spring bears the name of "Universal." All others are imitations.

The Acme of Perfection in a Mainspring and the BEST QUALITY of the BEST manufacturer in Europe.

DON'T use two dozen cheap springs for six watches while we GUARANTEE that you can rely on ELEVEN "UNIVERSALS" in every DOZEN.

Save Time, Money and Reputation
By Doing GOOD WORK with GOOD MATERIAL.

Price: \$1.50 per Dozen; \$15.00 per gross.

Packed in anti-rust tin boxes ESPECIALLY MADE FOR THIS SPRING.

For Sale by all Jobbers. Imported by

HAMMEL, RIGLANDER & Co.,
35 MAIDEN LANE, NEW YORK.

If you cannot obtain the UNIVERSAL from your Jobber, notify the Importers and they will supply you with a list of Jobbers who do keep it.

SOLID SILVER COFFEE SETS.



AFTER DINNER

COFFEE POTS.

ODD AND UNIQUE DESIGNS.



TURKISH, MOORISH

AND OLD ENGLISH

DECORATIONS, WITH SUGAR DISH,
TONGS AND TRAY TO MATCH.



GORHAM MFG. CO.,

SILVERSMITHS,

Broadway and 19th St.,

NEW YORK.

ALFRED H. SMITH & CO.,

DIAMONDS,

182 BROADWAY,

COR. JOHN STREET,

NEW YORK.

33 HOLBORN VIADUCT, LONDON, E. C.

THE JEWELERS' CIRCULAR AND HOROLOGICAL REVIEW.

PUBLISHED EVERY WEDNESDAY BY

THE JEWELERS' CIRCULAR PUB'G CO.,

AT NO. 189 BROADWAY, NEW YORK CITY.

A JOURNAL DEVOTED TO THE INTERESTS OF WATCHMAKERS, JEWELERS, SILVERSMITHS, ELECTRO-PLATE MANUFACTURERS AND ALL WHO ARE ENGAGED IN KINDRED BRANCHES OF INDUSTRY.

Terms of Subscription, Postage Prepaid.

	PER ANNUM
United States and Canada,	\$2.00
Foreign Countries,	4.00
Single Copies,	.10

ADVERTISEMENT.

Business letters, drafts, checks and post-office orders should be addressed to THE JEWELERS' CIRCULAR PUBLISHING COMPANY, No. 189 Broadway, New York city.

Manuscript from any quarter containing news or discussion of any technical subject within the field covered by THE CIRCULAR will be welcomed. Matter received that proves unsuitable or unavailable will be returned if accompanied by the necessary postage stamps.

Our editorial columns will contain our own opinions only, and we shall present in other columns only what we consider of interest or value to our readers. Applications to print advertising matter as news will not be considered.

Advertising rates in THE CIRCULAR are lower, considering the number of tradesmen reached by its large circulation, than in any other jewelry journal.

Notices of changes in standing advertisements must be received one week in advance, new matter can be received up to Saturday.

Member of the American Trade Press Association.

CLASSIFIED INDEX TO ADVERTISERS, PAGE 30.

VOL. XXII. APRIL 1, 1891. No. 9.

NOTICE.

New subscribers are taking advantage of our combination premiums to a gratifying extent, and to the mutual advantage of all concerned. The offer is an unusually good one, and it is no wonder that it is meeting with such prompt recognition. Subscribers will please bear in mind that it takes from two to three days to select and forward the premiums.

Dishonest Clerks and Gambling.

THE accounts in this issue of the operations of dishonest employes, sets us to reflection, and the question is again asked, how are the pilferings of clerks to be prevented. As there will be flaws in whatsoever system of checking and accounting of goods that a house may institute, it would seem that the subject for consideration should be the employé himself. The principal should know his young men as young men. He need not be cognizant of the manner they spend all their spare time, but he should know their passions and traits. Some vicious passions do not turn the wrong-doer from the path of integrity and faithfulness. The frequenter to the green table or racing track is, how-

ever, a being to receive attention. The simple occasional bettor is bound to be a loser, for his opponents are men whose profession it is to make money from the public. There is not a business transaction, giving something for something, but a bodily transfer of money from one to the other. The young man as he loses, is fired more and more to win. Some one who knows no more than himself, the turn of events, "gives him a tip," and he must "play it," or he thinks he must. If he is out of money he will borrow. At length he can borrow no more, and the end is too often disgrace. This picture is not over-colored; the history of private misery substantiates these details. The great army of sturdy, honest and faithful clerks earnestly desire their dishonest co-workers weeded from among them, and they will not think we have taken to obroad a stand.

Shall Safes be Exempt?

THE Supreme Court of California held, in the recent case of McManus Estate, that a safe used by a jeweler and watch repairer, should be set off to him in insolvency, under a provision of the State Code of Civil Procedure exempting from execution "the tools or implements of a mechanic or artisan necessary to carry on his trade." It is generally known that a jeweler's stock by reason of its great value confined in a little compass, is especially attractive to burglars, and that a safe is one of the few effectual preventives against robbery during the night hours. The minority of small dealers, who conduct business without this adjunct will suffer sooner or later. Only last week, a jeweler at Henry, Ill., who thought it unnecessary to have one, had, as stated in another part of this issue, his stock carried off during the night. It will thus be seen that to a jeweler and watchmaker a safe is as necessary an article to his business as a lathe, or other tool. The bankruptcy laws of the States, especially those in the western portion of the country, are perhaps too liberal. Still the matter of exempting a safe is open to consideration by merchants, and the legislatures of all the States.

One Way to Succeed.

THOUGH only a week has passed since the series of articles on Souvenir Spoons was commenced in THE CIRCULAR, numerous jewelers are advertising these goods to the public. We regard this as illustrating a principle of business that every dealer should appreciate. The life of a fad is as short as the word itself. Therefore, when one exists, the dealer should push his stock to the utmost; he should let everyone in his compass know what lines he is carrying; he should take space in his local newspapers, for that is the quickest and most effectual mode of advertising. As to general advertising, he should do so whenever opportunity

offers, especially when business is dull, as at the present time. It seems that he who does not advertise, and he who reports business to be dull, is very often one and the same man.

To Brand Imported Packages. SECTION 6 of the New Tariff Act, providing for the branding and stamping of all imported packages has now gone into effect. Under this section, the requirements are somewhat the same as those of the Merchandise Marks Act of Great Britain, and they are to effect essentially the same purposes. The United States should welcome this law, for the consumer on this side of the Atlantic will now be thoroughly enabled to test the qualities of imported productions, while foreigners will also have an opportunity of judging the relative merits of their own and American goods.

The Week in Brief.

Some displays at the Jamaica Exhibition. —An industrial Exhibition proposed at Providence, R. I.—The Imperial Watch Co., was in trouble at Duluth, Minn.—The window of A. R. Vaughan's store, Pawtucket, R. I., was smashed.—C. Rieck, Utica, Neb., had several attachments placed on his stock.—The death of H. Michaels, Jonesboro, Ark., occurred.—It was decided to establish a large factory at Fort Worth, Tex.—A reward was offered for the discovery of the body of the missing jeweler Swenson.—J. C. Adams, jewelry snatcher, was captured at Columbus, O.—A watch factory for Baltimore, Md., was proposed.—A jewelry peddler was murdered at Albany, N. Y.—By a railroad accident in Wisconsin, several thousand dollars worth of jewelry was destroyed.—C. P. Townsend, Kankakee, Ill., was held up in his own store.—The missing clerk of V. J. Pekor, Columbus, Ga., was found.—The Gloverville burglars were sentenced.—S. & B. Lederer, Providence, R. I., bought out the plant of Chas. Downs, deceased.—E. E. Biber & Co., Attleboro, Mass., assigned.—August Koenig, Fort Wayne, Ind., died.—David Mayer, Hartford, Conn., was compelled to pay for a traveler's license.—Robert Wallace, Halifax, N. S., expired.—Receiver Campbell, of the McBride & Marcellus Co., Cleveland, O., was removed.—The Chicago W. & J. Co. got in trouble at Newark, N. J.—The Crescent Watch Case Co. added a trustee to their Board.—The M. Eisenstadt Jewelry Co., St. Louis, Mo., will increase their capital stock.—The Retail Jewelers' Association, of St. Louis, Mo., met.—A meeting of the stockholders of the American Watch Co. was held.—J. P. May, vice-president of the Progress Watch Case Co., Newark, N. J., died.—J. Watercott, Henry, Ill., had his stock stolen.—The thieves who attempted to rob A. D. Ernie & Co., Cleveland, O., were sentenced.—Journeymen watch case makers organized at Brooklyn, N. Y.—C. W. Smith, Dubuque, Ia., died.

New York Notes.

Nathan & Hermann moved from 15 to 51 Maiden Lane, last Monday.

R. J. Rosenthal will move from 125 Bowery to 254 Bowery in a few weeks.

Samuel Hammond, 62 Wall St., suffered a bereavement in the loss of his mother, who died last week.

The Aluminum Brass and Bronze Co., last Thursday entered a judgment for \$119.14 against F. M. Curtiss.

In the City Court, last Thursday, Judge Newburger granted a judgment against Simon Stern for \$728.48 in favor of S. W. Kent.

R. A. Kipling will, on April 15, move from 31 Union Square to 189 Broadway, where he will occupy a portion of the office of Peterson & Royce.

Solomon Rose, diamond importer, 1013 Park Ave., was one of the jurors selected to try Alphonse Stephani, the alleged murderer, last Thursday.

A judgment for \$284.57 has been entered against Nathan Bachrach in favor of A. Kohn & Co. The latter firm has also detained a judgment for \$69.08 against Morris Green.

N. Gunzburger, of Gunzburger Bros., will, on April 8, sail for Europe on the *Lahn*, to purchase fall stock for his house. The firm will to-morrow move from 25 to 35 Maiden Lane.

Irving Vandergrift, a salesman for the Spencer Optical Mfg. Co., and an amateur legerdemain artist, will give an entertainment to his friends, in Everett Hall, Brooklyn, April 29.

The limited partnership of McCarty & Co., bric-a-brac importers, 525 Broadway, which terminated last Tuesday, has been renewed for two years, the firm consisting of B. E. McCarty and Elias Mead.

C. J. Dodgshun, for many years connected with the New York office of the Waterbury Clock Co., has been appointed to the management of the Chicago branch of that concern in place of H. S. Peck, who has severed his connection with the company.

The jewelers of Sixth Ave., who recently complained to Mayor Grant against the objectionable auctioneer's flag floating over the sidewalk between 15th and 16th Sts., will no doubt be interested to hear that Judge Bar-

rett, of the Supreme Court, has decided against a similar sign shown at 32 E. 14th St.

Charles A. Fowler, late of Fowler Bros., will with his family shortly start on a pleasure trip around the world, to extend over a period of two years. From New York he will journey to Vancouver, then to Alaska, Yokohama, the East Indies, Mediterranean ports and Cairo, at which place he will sojourn for some months.

Last Wednesday, O. M. Farrand, 1 Maiden Lane, obtained a judgment for \$125 against J. C. Snackenbergh. Some time ago, the latter obtained from Mr. Farrand a diamond

ring, valued at the sum named, on the plea of showing it to a customer. After securing possession of the jewel, he disappeared, and has not been seen since.

J. W. Stewart, assistant bookkeeper of the Spencer Optical Mfg. Co., 15 Maiden Lane, was married last Tuesday evening to Miss Coyler, of Brooklyn. The ceremony took place at the residence of the bride, and many members of the jewelry and optical trade were present. Mr. Stewart's employers sent him a handsome marble clock.

Sometime last November, S. E. Zimmern, 8 Maiden Lane, sold goods valued at \$923.87

JEWELERS ATTENTION!

DO YOU KNOW that we are making the only line of cuff buttons which are sold exclusively to the RETAIL JEWELRY TRADE?

DO YOU KNOW that the action or fastening of this button is the simplest, most durable and most salable of any in the market?

DO YOU KNOW that we are manufacturing a full line of these buttons in roll plate, gold front and solid gold?

DO YOU KNOW that this line of buttons was endorsed and recommended by the OHIO RETAIL JEWELERS' ASSOCIATION?

DO YOU WANT a line of cuff buttons which is not found in any Dry Goods, Gents' Furnishing or Millinery Store in the country—thereby preventing such ruinous competition?

Then send to us for a selection of our "**ANTI-SWEAR**" Buttons

J. T. SCOTT & CO.,

SOLE MANUFACTURERS,

4 MAIDEN LANE, - NEW YORK.

American Morocco Case Co.

FINE EBONY AND ROSEWOOD TRAYS.

ONLY MAKERS OF

SATIN FINISHED WHITE METAL CASES FOR RINGS, BROOCHES, EARSTUDS, COLLAR BUTTONS, ETC.

FINE VELVET & WHITE LEATHER CASES
FOR DIAMOND JEWELRY.

9 Bond Street, N. Y.

POLISHED HARD WOOD TRUNKS, FOR COMBINATION
SETS & CASES FOR SINGLE SPOONS.

to Edmund Heinecke, 29 E. Houston St. He received \$130 on account, but claims not to have been paid anything more since. Three weeks ago he began a suit in the City Court, to recover the remaining \$793.87, and last Thursday when it was called, Judge Van Wyck continued it until April 10.

The law firm of Hays & Greenbaum, 176 Broadway, who have conducted many jewelry litigations, have been elected attorneys for the New York Jewelers' Board of Trade in place of G. C. Comstock.

Judge Ingraham, of the Supreme Court, last Wednesday denied the application of Viemeister Bros. to vacate the attachment granted by Judge Beach against them on December 20 in favor of H. Henrich. The motion was made on the ground that the defendants had no intention of defrauding their creditors or illegally disposing of their property.

Several diamond rings, five breastpins and two chains were seized from G. Frankel, a passenger on the *Spreo*, which arrived on Thursday. More jewelry, the property of B. Steinhart, a passenger on the *Trave*, was also seized. In this collection were diamond bracelets, gold chains, rings, several silver pieces, and two cigar holders. In both instances the goods were held for duty.

Henry Van Dinter last week lived at 120 Waverly Pl., this city, and was employed as clerk in the store of Charles Poppen, 397 Palisade Ave., Jersey City. He is now confined in the Hudson County jail, where he was sent last Thursday to await trial on the charge of stealing watches from his employer. He is said to have pilfered from the store during a period extending over twelve months, and lost the money he realized on his plunder at the race track.

A story is going the rounds of the Western press to the effect that Wm. Grote, of Elgin, Ill., is endeavoring to have an "extensive clock manufactory" locate at that city. The representatives of several clock companies in this city when approached by a CIRCULAR reporter on the subject, said that they were wholly in ignorance as to what concern the report alluded to. They further stated that it was probably without foundation, as all of the established clock companies were satisfied with their present locations and would not incur the expense and losses that would result in a removal of their plant.

Peter Reuter, who is said to own a jewelry store on Ave. A., but whose name does not appear in the mercantile directories, was last Thursday held for trial by Justice Manley, of Long Island City, charged with deserting his wife. Mrs. Reuter claims that she once traced her husband to this city, and found him engaged in the jewelry business on Nassau St. According to her allegations when Reuter heard of her visit to the store, he had the large gilt sign with his name on it taken down, and one with the name of "Roetter" substituted. He resides at Hyde Park, L. I., and Mrs. Reuter claims he has married another woman.

Henry May last week moved into his new office in the Jewelers' Exchange, 51 Maiden Lane.

The Crescent Watch Case Co. have increased the number of their trustees from four to five, the new trustee being C. L. B. Crommelin. Mr. Crommelin, who has been for many years treasurer of the Crescent Co., retains that office.

Robert Ricked, 202 Broadway, sells jewelry on the instalment plan, and among his salesmen were R. W. Kegelmann, of Brooklyn. Some weeks ago the latter obtained about \$400 worth of rings, watches and

chains from his employer, on the representation that he had customers for them. He failed to return the jewelry or their value, and on complaint of Mr. Ricked was last Thursday arrested, and held in default of \$1,000 for trial.

Some months ago the wife of Michael Stark, a Staten Island car driver, purchased a pair of earrings and a pin valued at \$152 from Ludwig Hess of the Manhattan Watch and Jewelry Co., 611 Broadway, on the instalment plan. She subsequently died, and her husband being out of work pawned the jewelry. The next day he was arrested and

J. F. FRADLEY & CO.,

Manufacturers of a General Line of

REPOUSSÉ SILVERWARE, MATCH BOXES in Solid Gold and Stiffened Gold,
GOLD HEADED CANES, &c.

Office and Salesroom, 23 JOHN STREET, NEW YORK.

DORFLINGER'S AMERICAN CUT GLASS.

The Finest Crystal, Plain and Cut, made in the World.



EVERYTHING that is
used in Glass, for
the Table.

BEAUTIFUL, Artistic
and Useful Pieces
for Gifts.

Sells as well as Silver-
ware.

Rivals the Diamond for
Purity and Lustre.

EVERY FIRST-CLASS JEWELER

SHOULD KEEP IT.

C. DORFLINGER & SONS,

36 Murray Street, New York.



Fleur de Lis "VICTORIAS."

WE ARE SHOWING THE

Most Popular Line

IN THE MARKET.

H. F. BARROWS & Co.,

1½A Maiden Lane, N. Y.

CLASSIFIED INDEX TO ADVERTISEMENTS.

All Advertisements are entitled to one insertion under proper heading. Extra insertions, \$6.00 per Annum. Extra Headings \$12.00 per Annum.

	PAGE.		PAGE.		PAGE.
Assayers & Refiners.		Imported Clocks, Bronzes, Etc.		Sterling Silver Novelties.	
Howard, S. P., 8 John st., N. Y.....	52	Glaenzler, L. J., & Co., 80 Chambers st., N. Y.....	35	Alvin Mfg. Co., 860 Broadway N. Y.....	34
Robertson & Leber, 13 Franklin st., Newark, N. J.....	52	Jewelry Repairers.		La Pierre, F. H., 18 East 14th st., N. Y.....	49
Auctioneers.		Wiederhold, A., 20 Maiden Lane, N. Y.....	14	Lewis Bros., 41 Maiden Lane, N. Y.....	49
Comrie, A. J., 16 West 125th st., N. Y.....	18	Jewelers' Scales.		Sterling Silverware.	
French, J. H., Box 2775, N. V.....	27	Troemner, Henry, 710 Market st., Philadelphia, Pa.....	9	Fradley, J. F. & Co., 23 John st., N. Y.....	29
Badges, Medals, etc.		Jewelry and Silverware Cases.		Gorham Mfg. Co., 19 st. & Broadway, N. Y....	26
Stockwell, E. R., 13 John st., N. Y.....	22	American Morocco Case Co., 9 Bond st., N. Y.....	28	Shiebler, Geo. W., 6 Liberty st., N. Y.....	16
Black Onyx Jewelry.		Jackson, S. C., 180 Broadway, N. Y.....	9	Towle Mfg. Co., Newburyport, Mass.....	37
Woglom, Gilbert T., 32 John st., N. Y.....	42	Wiggers & Froelick, 60 Nassau st., N. Y.....	34	Wallace, R. & Sons, Mfg. Co., 3 Park Place, N. Y.....	6
Bronze Ornaments.		Jobbers, Watches, Diamonds, etc.		Wood & Hughes, 16 John st., N. Y.....	10
Muller Bronze Co., Brooklyn, N. Y.....	8	Aikin, Lambert & Co., 23 Maiden Lane, N. Y.....	40	Souvenir Spoons.	
Chronometers.		Beguelin, Tell A., 71 Nassau st., N. Y.....	42	Burbank, A. F., Worcester, Mass.....	45
Bliss, John, & Co., 128 Front st., N. Y.....	16	Bowman & Musser, Lancaster, Pa.....	21	Conover, D. F. & Co., Philadelphia, Pa.....	5
Heinrich, H. H., 14 John st., N. Y.....	36	Cross & Beguelin, 21 Maiden Lane, N. Y.....	13	Durgin, W. B., Concord, N. H.....	11
Clock Manufacturers.		Friedlander, R. & L., 65 Nassau st., N. Y.....	42	Glenny, W. H., Sons & Co., Buffalo, N. Y.....	10
Schlenker, E. R., Schwenningen on Neckar, Germany.....	10	Koch & Dreyfus, 22 John st., N. Y.....	47	Gorham Mfg. Co., Union Square, N. Y.....	23
Waterbury Clock Co., 10 Cortlandt st., N. Y....	44	Myers, S. F. & Co., 48 Maiden Lane, N. Y.....	52	Hansell, Sloan & Co., Hartford, Conn.....	7
Cut Glass.		Scott, J. T. & Co., 4 Maiden Lane, N. Y.....	28	Harris & Shafer, Washington, D. C.....	20
Clark, T. B. & Co., 53 Park Place, N. Y.....	47	Yates, John B., 147 Nassau st., N. Y.....	46	Jones, William P., Newburyport, Mass.....	22
Dorfinger, C. & Sons, 36 Murray st., N. Y.....	29	Musical Boxes.		Merrill, J. A., & Co., Portland, Me.....	39
Diamond & Precious Stone Importers.		Jacot & Son, 298 Broadway, New York.....	42	Moore & Leding, Washington, D. C.....	45
Gunzburger, 51 st., 35 Maiden Lane, N. Y.....	52	Optical Goods.		Myrick, Roller & Holbrook, Philadelphia, Pa..	11
Hedges Wm. & Co., 170 Broadway, N. Y.....	41	Geneva Optical Co., 23 Washington st., Chicago, Ill.....	18, 41, 42	Spear, H. T., & Son., Boston, Mass.....	21
Hirschberg, Sig., 78 Nassau st., N. Y.....	49	Scheidig, John & Co., 43 Maiden Lane, N. Y....	37	Whiting Mfg. Co., Union Square & 17th St., N. Y.....	4
Kahn, L. & M. & Co., 10 Maiden Lane, N. Y.....	52	Spencer Optical Co., 18 Maiden Lane, N. Y....	51	Tool Manufacturers and Dealers.	
Kipling, E. E., 2 John st., N. Y.....	52	U. S. Optical Co., 1 Union Square, N. Y.....	18	American Watch Tool Co., Waltham, Mass....	15
Kipling, R. A., 31 Union Square, N. Y.....	41	Order Work.		Bullock, O. W. & Co., Springfield, Mass.....	42
Oppenheimer Bros., & Veith, 35 Maiden Lane, N. Y.....	43	Maxheimer & Beresford, 3 Maiden Lane, N. Y.....	41	Nordman Bros., San Francisco Cal.....	16
Randei, Baremore & Billings, 29 Maiden Lane, N. Y.....	17	Tissue Paper.		Swarthchild & Co., Chicago, Ill.....	36
Smith, Alfred H. & Co., 182 Broadway, N. Y....	26	Diamond Paper Mills, 44 Murray st., N. Y.....	13	Typewriters.	
Tavlin & Bro., 860 Broadway, N. Y.....	44	Pens, Pencil Cases, Etc.		Wyckoff, Seamens & Benedict, Broadway, N. Y.	36
Wheeler, Hayden W. & Co., 2 Maiden Lane, N. Y.....	43	Aikin, Lambert & Co., 23 Maiden Lane, N. Y.....	40	N. Y.....	45
Diamond Cutters.		Ring Makers.		Watch Companies.	
Groenman, A. J. & Co., 80 Nassau st., N. Y.....	13	Bowden, J. B. & Co., 192 Broadway, N. Y.....	39	Columbus Watch Co., Columbus, O.....	50
Diamond Jewelry.		Bryant, M. B. & Co., 10 Maiden Lane, N. Y.,	10	Non-Magnetic Watch Co., 177 Broadway, N. Y.	40
Bynner, T. B., 177 Broadway, N. Y.....	34	Haskell, H. C., 192 Broadway, N. Y.....	45	Trenton Watch Co., Trenton, N. J.....	14
Falkenau, Oppenheimer & Co., 40 Maiden Lane, N. Y.....	52	Hildreth Mfg. Co., 51 Maiden Lane, N. Y.....	16	Watch & Clock Dials.	
Nissen, Ludwig, & Co., 18 John st., N. Y.....	14	McCall, Wm. E., 625 Arch st., Philadelphia, Pa.....	16	Waltham Dial Co., Waltham, Mass.....	13
Pinover, A. & Co., 25 Ann st., N. Y.....	9	Ostby & Barton, 80 Clifford st., Providence, R. I.....	46	Watch & Clock Oils	
Sexton Bros. & Ashburn, 41 Maiden Lane, N. Y.....	41	Wood, J. R. & Sons., 14 John st., N. Y.....	16	Ginnel, Henry & Co., 31 Maiden Lane, N. Y....	16
Stern Bros., 42 Maiden Lane, N. Y.....	41	Rolled Plate Chains.		Nye, William F., New Bedford, Mass.....	18
Engravers and Designers.		Barrows, H. F. & Co., 1 1/2 A, Maiden Lane, N. Y.....	29	Watch Keys.	
Bartholomey & Eckham, 18 Spruce st., N. Y.....	46	Kent & Stanley, 7 Eddy st., Providence, R. I....	3	Clark, A. N., Plainville, Conn.....	41
Ryder & Dearb., 146 Westminster st., Providence, R. I.....	46	Rolled Plate Jewelry.		Kendrick & Davis, Lebanon, N. H.....	14
Eye Glass Holders & Chains.		Crossin & Tucker, 409 Pine st., Providence, R. I.....	13	Watch Case Manufacturers.	
Merritt, S. F., Springfield, Mass.....	9	Filmerfelt, J. A. & Co., 177 Broadway, N. Y....	52	Crescent Watch Case Co., 5 Bond st., N. Y....	12
Gold and Silver Platers.		Foster & Bailey, 60 Richmond st., Providence, R. I.....	16, 25	Essex Watch Case Co., Newark, N. J.....	44
Newman, Louis, Jr., 36 John st., N. Y.....	47	Ludwig, H. & Co., Providence, R. I.....	39	Jeannot & Shiebler, 20 Maiden Lane, N. Y.....	16
Gold Jewelry.		Plainville Stock Co., Plainville, Mass.....	42	Muhr's Sons, H., 629 Chestnut st., Philadelphia, Pa.....	52
Bipart & Co., Newark, N. J.....	48	Seal Engravers.		Roy Watch Case Co., 17 Maiden Lane, N. Y....	52
Carter, Sloan & Co., 15 Maiden Lane, N. Y....	49	Park, William, 26 John st., N. Y.....	17	Wadsworth, H. A. & Co., Newport, Ky.....	38
Cottle, S. Co., 860 Broadway, N. Y.....	42	Seamless Wire.		Watch Case Repairers.	
Dav & Clark, 10 Maiden Lane, N. Y.....	9	Burdon Seamless Filled Wire Co., Providence, R. I.....	42	Femier, G. F., 9 Bond st., N. Y.....	36
Krementz & Co., 182 Broadway N. Y.....	35	Settings & Galleries.		Felix, N. J., 71 Nassau st., N. Y.....	51
Larter, Elcox & Co., 41 Maiden Lane, N. Y....	17	Blancard & Co., 36 John st., N. Y.....	42	Watch Importers.	
Morris, 10 Maiden Lane, N. Y.....	16	Show Cases and Fixtures.		Abry, Chas. L., 41 Maiden Lane, N. Y.....	36
Roy, 10 Maiden Lane, N. Y.....	34	Smith, B. & W. B., 220 W. 29th st., N. Y....	52	Didisheim, Hipp, 83 Nassau st., N. Y.....	17
Schaefer & Westcott, 10 Maiden Lane, N. Y....	13, 21	Silk Guards.		Hydes' Sons, John E., 22 Maiden Lane, N. Y....	36
Seet, Geo. O. & Sons, 18 John st., N. Y.....	10	Rosentall, Wm., 79 Nassau st., N. Y.....	34	Mathey Bros., Mathez & Co., 14 Maiden Lane, Wittnauer, A., 30 Maiden Lane, N. Y.....	39
Gold Chains.		Silver Plated Ware.		Watch Materials, &c.	
Ricker & Shiebler Newark, N. J.....	40	Pairpoint Mfg. Co., New Bedford, Mass.....	5	Cross & Beguelin, 21 Maiden Lane, N. Y.....	13
Horological Schools.		Rogers, Wm., Mfg. Co., Hartford, Conn.....	18	Friedlander, R. & L., 65 Nassau st., N. Y.....	42
Chicago School of Horology, Chicago, Ill.....	26	Rogers & Hamilton Co. The, Waterbury, Conn.	52	Keller, L. H. & Co., 64 Nassau st., N. Y.....	9
Elgin Horological School, Elgin, Ill.....	10	Rogers & Bro., 16 Cortlandt st., N. Y.....	44	Watch Repairers.	
Waltham School of Horology, Waltham, Mass.	42	Stem-Winding Attachments.		Juzek, Thos. & Co., Elgin, Ill.....	41
Hotels.		Abbott, Henry, 4 Maiden Lane, N. Y.....	43	Simmonds, J. C., 18 John st., N. Y.....	47
Russell House, Chicago, Ill.....	16			Watch Springs.	
				Hammel, Riglander & Co., 35 Maiden Lane, N. Y.....	25
				Washburn & Moen Mfg. Co., Worcester, Mass.	16
				Welded Steel.	
				Chrome Steel Works, Brooklyn, N. Y.....	47

Special Notices.

Rates 75c. per insertion for notices, not exceeding 3 lines; additional words 2 cents each. If answers are to be forwarded, postage stamps must be enclosed. Two insertions, 10 per cent. off; three insertions, 15 per cent. off; four insertions, 25 per cent. off. Payable strictly in advance.

Situations Wanted.

THE JEWELERS' CIRCULAR has a guaranteed circulation of over 10,000 copies weekly. It is, therefore, the best medium for reaching the trade. To demonstrate this to advertisers, notices in this column will be inserted free of charge during the month of April.

A LIVE young man of ability and experience desires position with responsible house to represent them on the road; jewelry or watches preferred; familiar with southern trade; A 1 references. Address, Salesman, care of JEWELERS' CIRCULAR.

A NICKELPLATER desires a situation; thoroughly understands the business; can give best of reference if required. Address, Plater B, this office.

A YOUNG MAN, aged 21, who has worked at the watchmaker's bench about two years, wants to finish the trade with a good workman; good reference; good habits. Address, N. R. H., 232 West 5th st., Hutchinson, Kansas.

BOY wants position in Watchmaker's repair shop, where he can learn the trade, and where his services will be accepted as pay for instruction. Address, W. D. Clark, 250 E. Gregory st., Pensacola, Fla.

BY young married man, as engraver, general workman and salesman; wages moderate; good references. Address, D. F. Lenton, Romeo, Mich.

POSITION wanted as salesman in jewelry store; have had 5 years' experience; best of references; New England preferred. Address, H. A. Thrasher, 35 Princeton st., East Boston, Mass.

on complaint of Hess held for stealing it. The matter was brought to the attention of the Grand Jury by the concern, asking for the release of the prisoner. The request was complied with, and now the car driver has begun suit in the Richmond County Supreme Court against Mr. Hess for false imprisonment, claiming \$10,000 as damages. The suit was brought at the instigation of the foreman of the Grand Jury.

R. A. Breidenback has moved from 26 John St., to the Jeweler's Exchange, 51 Maiden Lane.

Mrs. Theresa Lynch has satisfied a judgment for \$59.90, entered against her on February 5 by M. Dalmage.

Auctioneer French is still continuing the selling of M. Panon's stock at 931 Broadway. Mr. Panon will soon move to 1149 Broadway.

Judgments have been entered against the Electro-Metallizing Co., for \$331.05, and \$148.81 in favor of the estate of F. W. Gesswein and J. A. Kent respecting.

Inspector Byrnes is investigating the business of "J. C. Minden, care of C. Pyke, 134 E. 13th St., New York," who is alleged to have victimized country residents in a both new and novel manner. He advertised to sell diamonds, watches and all kinds of jewelry at less than cost, and when J. C. Amstutz, Fort Wayne, Ind., ordered \$300

POSITION wanted with a first-class house, by practical watchmaker, with 12 years' experience at the bench. Wages expected, \$18 per week; good references. Address, Sober, care of THE JEWELERS' CIRCULAR.

SITUATION WANTED.—By young man 25 years of age; single; good watch and clock repairer; references. Address, Frank Schaeppi, P. O. Box 44, Norwood, Ohio.

SITUATION WANTED with first-class watchmaker, as assistant, where I can be instructed in staffing, etc. Address, W. J. Greenawalt, Reading, Pa.

WANTED.—A situation for a good watchmaker that I can recommend. Address, W. F. A Woodcock, Winona, Minn.

WANTED.—By a single man of about 30, with nineteen years' experience in the trade, a position as first-class watchmaker and repairer. Is familiar with the use of the lathe. Address, John Scherer, care THE JEWELERS' CIRCULAR.

WANTED.—Situation as traveling salesman for a jewelry house, by young man of 21; good habits; best references. Address, Edw. Richter, 666 York st., Newport, Ky.

WATCHMAKER wishes a situation; A 1 references. Address, Burton H. Bell, Clyde, O.

YOUNG married man desires a permanent position as malter rolling, press and drop work; can work at bench. Address, B. S., Hobard st., Perth Amboy, N. J.

Help Wanted

A FIRST CLASS watchmaker wanted; wages, \$20 per week. Send photograph and references. Address, P. H. Lachicotte & Co., Columbia, S. C.

WANTED.—Optician and engraver, optician and watchmaker, and engraver who can assist in selling and displaying goods in a large Southwestern city; as engraver, work must be good; only competent men need apply, stating age, salary and references; steady positions are assured the right men. Address, competent, care of THE JEWELERS' CIRCULAR.

worth of fine watches, he was told he would receive goods to the value of \$700. The consequence was as reported in THE CIRCULAR last week.

A meeting of the creditors of Seaverns & Co., Boston, was called for yesterday afternoon, in the office of attorney Franklin Bein, 324 Broadway, by G. Morse, one of the assignees.

Theodore Lexow, of Lewisohn & Co., 41 Maiden Lane, last week, recovered from the police the diamonds that were stolen from him by W. C. Duncan, and found in the safe of the Astor House.

Mrs. Theresa Lynch is about to retire from the jewelry business for a long rest. C. W. Schuman's Sons have taken a twelve years' lease of her store at 939 Broadway where they will establish a branch of their Union Square house.

The examination of Simon Stern, of Stern & Stern, in the suit brought against him by the Bay State Watch Case Co., Boston, Mass., was begun before Commissioner Thomas Alexander, in the Federal Building last Thursday.

H. H. Fudger, of the Goldsmiths' Stock Co., Toronto, Can., sailed for Europe last week, on the *Aurania*; A. Ludeke and Henry Rogers, New York, on the *Saale*. H. Lorsch, of Sussfeld, Lorsch & Co., New York, arrived on *La Champagne*.

For Sale.

A FINE ship chronometer for sale cheap. Address: A. C. Taylor, Cedar Rapids, Iowa.

FOR SALE.—On account dissolution of partnership, three iron safes; one fine "Herring Patent Champion"; also fixtures, shop tools, etc. Apply to Moore & Horton, 11 Maiden Lane, New York.

FOR SALE.—One of the best jewelry stores in New England city of 20,000; stock \$4,000. A big chance for man with cash. Address, C. D. N., care of THE JEWELERS' CIRCULAR.

To Let.

TO LET.—One office on first floor, one on second floor, and one third floor, of Knapp Building 41 and 43 Maiden Lane, N. Y.

Business Opportunities.

\$2,000 IN CASH and two thousand in notes, will buy old-established and paying jewelry business near New York. Address, Wm. McAdie, with Rogers & Bro., 16 Cortlandt St., N. Y.

\$2,500 SECURES an opportunity of a lifetime, for a jewelry business in the great and growing State of Washington. Address, R., care of THE JEWELERS' CIRCULAR.

Miscellaneous.

W. F. A. WOODCOCK'S SCHOOL FOR WATCH makers, Winona, Minn., offers unrivaled facilities for acquiring a thorough practical knowledge of every branch of the business. Terms very reasonable.

WORK FOR THE TRADE.—All kinds of watch and jewelry repairing. Skillful workmen, prompt attention and satisfaction guaranteed. Address, A. W. Johanson, 176 & 178 Market st., Chicago, Ill.

Bernard Freitag, George Freitag and Peter Dolan, none of whom are over twelve years of age, were arrested last Saturday in the act of stealing jewelry from the trays on the counters at Ridley's store on Grand St. Justice Murray remanded them for examination.

J. P. May, vice-president of the Progress Watch Case Co., 41 Maiden Lane, died last Friday of consumption, after a lingering illness. Mr. May was at one time connected with the American Waltham Watch Co., and before the Progress Company was incorporated was one of the firm of Pinnell, May & Co., predecessors of the company. He was thirty-three years of age, and his death occurred at his home in Plainview, L. I.

Among the creditors of Viemeister Bros., Greenpoint, L. I., who recently failed was the W. L. Gilbert Clock Co. Last Wednesday G. C. Comstock, on behalf of the company, began the examination of Edmund Viemeister, his wife, and several other witnesses in supplementary proceedings, before Referee Gale, 26 Court St., Brooklyn. No facts other than has already been published were elicited, and the matter was adjourned for one week.

Moore & Horton, 11 Maiden Lane, New York, who recently dissolved, want a customer for their Herring safe, and also for their tools and office fixtures, etc.

Providence.

M. Weinberg, of Quebec, has been in town. T. J. Gardner, of T. J. Gardner & Co., has gone West.

C. E. Child has enlarged his jewelry plant at Warren owing to increasing business.

E. B. Ingraham, who has been confined to his house by brain fever is convalescing.

A. A. Wightman, of Wightman & Hough, has returned from a pleasure trip to California.

C. W. Battey has returned from a successful Western trip in the interests of Waite, Mathewson & Co.

T. W. Foster, of Foster & Bailey, has purchased real estate in East Providence of Rufus Waterman.

G. R. Clarke, of the Clarke Jewelry Co., has given a chattel mortgage of \$1,900 to R. G. Mowry on all the machinery and contents of 108 Eddy St.

G. F. Palmer, for many years head clerk and bookkeeper for his father, J. H. Palmer, at 16 Arcade, died recently in this city in the 31st year of his age.

The shop formerly occupied by A. B. Day & Co., at 195 Eddy St., is being refitted and will be annexed to the shop already occupied by Michael Fitzgerald & Co.

H. M. Tanner recently presented Park Hall Lodge of Odd Fellows, of which he is past Grand Master, with the implements of the Noble Grand and the Vice Grand.

S. & B. Lederer have purchased the plant of the late Charles Downs, at 61 Peck St., and will, it is understood, continue the business under the firm name of the C. H. Downs' Mfg. Co.

H. F. Eddy, with S. B. Champlin & Son, was united in marriage last week to Miss Gertrude L. Taylor. Among the numerous presents was a handsome dinner set from the employés of S. B. Champlin & Son.

A circular has been received by several of the manufacturers in this city from one A. Samuel, who styles himself a commission merchant in Chicago. No satisfactory information can be gained from any inquiries about the party, although he gives his reference as the Western Trust and Savings Bank.

Among the foreign importations received in this city during the past week were the following: From Bremen, one package of imitation stones; from Hamburg, one package of imitation stones and one package of hair chains; from Havre, nine packages of imitation stones. The total value of importations, \$24,968.

Costello & Corbett is the name of a new firm which has started in the business of manufacturing gold and silver filled plated beads at the corner of Bassett and Butler Sts. The firm is composed of John Costello and R. E. Corbett. The former was once in the dress-button business under the style of the Costello Mfg. Co., but recently he has been in the employ of W. L. Tobey. Mr. Corbett has for several years been in the employ of W. L. Ballou & Co.

In the Municipal Court on Tuesday the will of C. J. Clase, deceased member of the firm of Vennebeck & Clase, was proved and letters testamentary were ordered to issue to H. O. Tripp named executor in the will.

Mary E. Harrington intends to erect a three-story brick building for business purposes at the southeast corner of Broad and Richmond Sts., at a cost of \$16,000. It is understood that several rooms and offices have already been spoken for by parties connected with the jewelry business.

The State Board of Soldiers' Relief has unanimously elected Capt. B. L. Hall, of this city, as Superintendent of the Soldiers' Home. He enters upon his duties April 1. Capt. Hall has been long and favorably known in military circles, having been honored with the office of Department Commander of the Grand Army, serving with credit and distinction in the Rebellion and also in the First Light Infantry Regiment.

The Attleboros.

C. A. Whiting was at Wade, Davis & Co.'s factory this week.

T. E. Carpenter has returned from a Western business trip.

Many of the jewelry shops are only running eight hours a day.

W. H. Smith, of Smith & Crosby, started Wednesday on a trip to Hot Springs, Ark.

F. O. Coombs, formerly of Mauser & Coombs, has opened a cigar store under the name of the Bristol Cigar Co.

Capt. Mathewson, who recently severed his connection with Wade, Davis & Co., has taken a position with E. Ira Richards & Co.

D. E. Reed, late of the Plainville Stock Co., was Tuesday evening presented with a handsome marble clock by his old employées.

C. H. Cummings, with Sturdy Bros., received the scarlet degree collar at the Odd Fellow's fair, as being the most popular member of that order in the town.

E. E. Biber & Co., manufacturers of spectacle frames, etc., made an assignment to John P. Bonnett last Saturday. The members of the firm are E. E. Biber and Amand Witzke.

Fred Lincoln, formerly of Lincoln & Nerney, colorers, is spending his vacation here. He is at present employed as an instructor at the Y. M. C. A. gymnasium at Springfield, Mass.

August Koenig Expires.

FORT WAYNE, Ind., March 25.—At an early hour this morning occurred the death of August Koenig after a brief prostration with consumption, at his home, 161 Holman street. The deceased came to this city from Huntington a year ago, and opened a jewelry store at 176 Calhoun street, where he conducted the business up to the time of his death. Deceased was born in Germany and was in his 43d year. A widow and two young daughters survive him. The deceased was a most devout Catholic.

Cincinnati.

J. S. Lake of the American Watch Co. is in this city.

John A. McDonald commenced suit in the Superior court on Friday morning against Herman Lange, 181 Vine St., to enforce the payment of \$708.40, due by a promissory note.

Chas. Rauch, traveler for Strauss & Stern, celebrated his 50th birthday last week. His host of friends gave him a reception in the evening. He was handsomely remembered by the firm.

D. Jacobs & Co. received this week one hundred cases of clocks. They have a variety of church or hall clocks, with calendar attachment. Mr. Jacobs says his firm intend to make a specialty of clocks.

J. C. Ashton, proprietor of the Pittsburgh Reduction Co. has opened a Cincinnati Pure Aluminum Co., and offers to the public every variety of production known to be manufactured from this metal. He has on display in an office in the Burnet House, some exquisite art pieces in plaques, fans and writing desk equipments that are attracting general attention.

John Holland has received an order from Henry Troemner, the scale manufacturer of Philadelphia, to make bearings of iridium for the scales used by the U. S. Government on which all the gold used for coinage is weighed. They have been testing iridium the past three years, and have now decided to use it in place of steel for this purpose.

Michie Bros., 174 W. Fourth St., are creating a furor among the rheumatic portion of the populace, by the sale of an electric ring made by a firm in Chicago, which is recommended to effect a permanent cure. They have sold fifty-two dozen and still the demand increases. The funny part about it is, everybody who has tested the ring is ready to give a testimonial to its efficiency.

During Easter week the jewelers outdone themselves. With plenty of leisure, and elegant goods they made their windows radiant. Clemens Hellebush took the hue of the first Spring flower, the daffodil, and with a mingling of white, he made a very attractive background for his fine Easter novelties. Duhme & Co. used a lower ground of brown plush with delicate brocade drapery. Oskamp, Nolting & Co. are never happy unless they have diamonds of priceless value in their window. Blue and white contrast well with the articles displayed. A. G. Schwab & Bro. made no change for Easter, preferring to use the black. The beauty of their window is due to the simple display of choice articles. D. Schroder & Co. say their window is too broad; it thus compels a large display. The house displayed many beautiful Easter novelties. Strauss & Stern brightened up their immense windows with some very handsome articles. A. & J. Plaut's windows drew crowds. They had Goetheim, the art-student, to attend to the decoration.

Among the local dealers there was the same fever for fine and elaborate display. E. E. Isbell & Co. invariably use fine lace.

Homan & Co. have remodeled their cases in their sales room in order to make a more effective display of their new goods. The first case on the East side will be devoted to their new tea sets. The shelving is graduating and the whole lined with black cloth. The next case has a number of bracket shelves upon which their new baking dishes are displayed. One case will be devoted exclusively to novelties, tête-a-tête sets, cups and plates in imitation of the Royal Worcester patterns, individual butters, salvers, from the four to the eighteen-inch, bon-bon boxes, ink platters, and pierced photo frames.

Connecticut.

Miss M. A. Cowlshaw and W. G. Coxter, of Blair & Coxter, Hartford, were married on Thursday.

Prof. A. J. Cross, eye specialist, has located for a short time at Lake, Strobel & Co.'s store, Waterbury.

The Derby Silver Co. close their store in New Haven by May 1st. The auction sales held daily are very successful.

Prof. B. B. Clark, specialist in diseases of the eye, is stopping for a few days at A. H. Bron & Son's store, New London.

Mrs. A. D. White, New Haven, has now decided to close out her store in that city also, as the building will be torn down.

C. H. Stoekder, one of the best known traveling salesmen for the Meriden Britannia Co., has just started on an extended western tour.

C. G. Earle, New Haven, who is closing out his store, expects to dispose of most of his goods before May 1st, after which he moves to New York.

Assistant Treasurer and Superintendent C. E. Misse, of the Aluminum Brass & Bronze Co., Bridgeport, who was active in establishing that concern, has resigned.

S. H. Kirby, New Haven, has just sold his attractive and romantically situated residence on St. Ronan St., to Prof. J. Sumner Smith, assistant librarian at Yale College.

Meriden's selectmen have just ordered a new \$1,500 Howard clock for the tower of the town hall. The clock will be placed in position in sixty days. The dial will be seven feet in diameter.

The engagement is announced of Miss Grace Perry, of Farmington, and Wingate Howard, formerly of Hartford and now treasurer of the Middletown Plate Co., Middletown. The wedding will take place about the middle of April.

David Mayer, Hartford, was compelled by Captain Cady, at Rockville, to pay a salesman's license of \$5 for one month, last

week. He has been coming to this city for about three months, and objected to paying the regular license of \$50 per year. He brought the matter before the Common Council and they decided that there was no reason why he should not pay for a license.

Canada and the Provinces.

A new jewelry store has been opened at 37½ Gottingen St., Halifax, N. S., by E. H. Roome.

G. H. Guzzwell, North Sydney, N. S., is taking a course at the American Horological Institute, Philadelphia, Pa.

A. L. Watson, formerly chief operator in the C. P. R. telegraph office in Halifax, N. S., has opened a jewelry store at North Sydney, N. S.

A fire broke out in the store of A. Marks, 48 Sparks St., Ottawa, Ont., last week, but it was extinguished before much damage was done.

G. A. Huestis has sold out his business at Windsor, N. S., to F. P. Webster, a young man who has been in Mr. Huestis' employ for the past seven years.

J. T. Bolt, Montreal, P. Q., is about to move from his old stand at 41½ Bleury St., to 657 Craig St., the place lately occupied by the missing jeweler, Swenson.

Julius Cornelius has moved temporarily into the store one door north of his premises on Granville St., Halifax, N. S. His store is being handsomely remodelled.

A plush curtain in A. McCarter's store, Ingersoll, Ont., caught fire the other day. The fire was soon extinguished. The loss amounted to about \$100, fully insured.

J. E. Tremblay, who has been manager for a number of years for A. & A. F. McMillan, Ottawa, Ont., is about to start for himself in that city as a retailer. The style will be J. E. Tremblay & Co.

The cost in Canada of ascertaining the assay of gold and silver is now only \$1.59; two or more samples \$1. The reduction has been made to encourage the prospecting and development of minerals.

Probably the largest lot of clocks ever imported into the maritime provinces at one shipment was entered at the New Glasgow, N. S., Custom House last week by James Eastwood. The lot numbered between five and six hundred.

George Smith, brother of the Smith Bros., Kingston, Ont., and a salesman of the Montreal branch of Simpson, Hall, Miller & Co., is out again. He was badly injured in a railway accident two months ago. He is now preparing to start on the road.

D. Barton, Cowansville, Ont., has sold out his stock to F. E. Draper, one of his employees, and is about to open up a large wholesale material and repair store on St. James St., Montreal, P. Q. The style of the new firm will be Carton & Wood.

Louis St. Jean is about to leave the employ of his brother, Leger St. Jean, Montreal, P. Q. He is going to start for himself near Quebec.

The death occurred at Halifax, N. S., on last Sunday of Robert Wallace, the well-known jeweler and sewing machine agent. The deceased contracted a cold about a week before his death, which developed into pneumonia. He was in excellent health up to the time of his taking cold. Mr. Wallace kept a jewelry store at 194 Upper Water St. for many years, and about a year ago moved to Barrington St., near the Parade. The deceased was 58 years of age.

Newark.

E. A. Young moved last week from 57 to 53 Market St.

The jewelry store of Mrs. C. F. Gotthold, 870 Broad St., was entered by thieves on Sunday night. A single watch valued at \$4 was stolen, but the damage done the place by the thieves amounted to about \$25.

Eastwood & Park, manufacturing jewelers, 481 Washington St., are making extensive improvements, and by the latter part of next week will have materially enlarged their establishment, which has become too small for their business.

Adolph Dezeris, a well-known journeyman jeweler, of 420 Halsey St., died on Thursday afternoon, after a severe attack of the grippe, or, what is described in the death certificate filed by Dr. A. C. Dougherty, as a case of "capillary bronchitis."

Those Gloverville Burglars.

NEW YORK, March 28, 1891.

To the Editor of *The Jewelers' Circular*:

We are informed by Mr. Pinkerton that he has just received a telegram from Johnstown to the effect that James, *alias* "Biggy" Donovan, one of the participants of the burglary of A. D. Norton, one of our members, has been indicted, convicted and sentenced to six years and six months in Clinton Prison. The Alliance has reason to congratulate itself as in addition to the conviction of Donovan several others have been indicted as accomplices, and the greater portion of the stolen goods recovered.

It will be remembered that Mr. Norton's store was burglarized on the night of June 10th, 1890, and about \$25,000 worth of property was taken. The Alliance took entire charge of the case, and have been quietly and persistently working upon it ever since. The above result testifies to the protection it gives its members, and warns the burglar to leave alone all those who are under its care.

Yours respectfully,

GEO. H. HODENPYL, SEC'Y.

Niagara Falls, N. Y., March 21, 1891.

I consider *The Circular* indispensable, premium or no premium.

Max H. Elbe.

TRADE GOSSIP

A retail jeweler with original ideas can earn fifty dollars in a few minutes by answering the advertisement of Henry Abbott, published in another column.

Rickert & Stiehle, 13 Franklin St., Newark, N. J., manufacture an extensive line of gold chains, swivels and spring rings, which are receiving gratifying attention from the trade.

Jewelers having movements requiring new parts, such as balance staffs and chronometer locking springs, should send to John C. Simmonds, 18 John St., New York, who makes a speciality of fine watch repairing.

T. B. Clark & Co., cut glass manufacturers, 53 Park Place, New York, have adopted a new shape for their water bottles, which they claim has some advantages over the old style. The Avon pattern which they recently put on the market, is finding a ready sale.

J. F. Fradley & Co., artistic workers in gold and silver, 23 John St., New York, exhibit a wonderfully handsome line of rich repoussé goods this Spring, including candlesticks, bonbons, sugars, pitchers, fine stationery, novelties, etc. These goods are all finished in the style that has established the reputation of this house as producers of one of the finest lines of silver goods in the country.

The Wadsworth Watch Case Co., Newport, Ky., have just got out their new 16-size cases, and the first output has already been absorbed. Mr. Walton, their traveler will go West next week for a short trip. The new case is made in all the styles of the 18-size which has had such a run. A number of new designs are shown in the 6-size.

Frank H. La Pierre, the manufacturer of silver novelties, 18 E. Fourteenth St., New York received so many calls for his "Good Friday Novelties" advertised in THE CIRCULAR, that he is unable to supply the demand. He has an unusually attractive line of book-marks, which are new in design and very salable at this season of the year.

The Dueber cases as well as the Hampden movements have for years been recognized as among the leaders in American productions of their kind. Encouraged by the demand for these goods, Oppenheimer Bros. & Veith, 35 Maiden Lane, New York, have made a speciality of them and jewelers about to purchase, would do well to bear them in mind.

John Holland, Cincinnati, O., has found a new market for his pearl manilla shells that he imports from the Chinese Sea to make pen-holders of; some ladies took a fancy to have some ice-cream sets of the smaller size, and Mr. Holland has displayed some as card receivers. They are capable of a very high polish, and are beautiful. Where man's ingenuity fails, woman comes to the rescue, and points the way to fame. This new idea worked up will bring another novelty before the public, which is always craving something new.

Foster & Bailey, Providence, R. I., are preparing to enter the field in the chain line. They have been engaged for a year and a half in perfecting tools and machinery to reduce the cost of chain-making, and now promise a superior line of goods at low prices. This is in addition to their already extensive line mentioned in their advertisement.

No watch repairer can afford to place a poor spring in a movement when left with him. The chances are that, after a few weeks use, the steel becomes affected by the atmosphere and snaps; the customer immediately condemns the jeweler, and takes his trade somewhere else. All this is avoided by the use of the Universal mainspring, which is imported by Hammel, Riglander & Co., 35 Maiden Lane, New York. This spring is uniform in color and exact in size.

We call the attention of our readers to the illustrations of the damaged watch cases in the advertisement of N. J. Felix, 71 Nassau St., New York, and also to the appearance of one of these cases, after it had been manipulated by the skilful hands of Mr. Felix. These are no fancy sketches, but exact fac-similes of cases sent by one of our largest jobbers to him for repairs. Our readers can rely on Mr. Felix's skill to repair any case, and also on the moderation of his charges.

In another part of this issue will be found an advertising announcement of the Columbus Watch Co. that should be thoroughly noticed by the trade. In the discontinuance of two such favorite movements as Nos. 27 and 97 have proved themselves to be, the Columbus Watch Co. are only carrying out a policy of good judgment in trying to keep the number of high grade movements down to as near a minimum as possible. They state that the supply on hand of 27s and 97s is not large, and that the price will move them quick, and those retailers desirous of obtaining a chance at these movements will do well to put in an early plea with their jobbers. "A word to the wise" should be sufficient.

W. ROSENTALL,
79 NASSAU ST., N. Y. Manufacturer of

Silk Vest Chains.

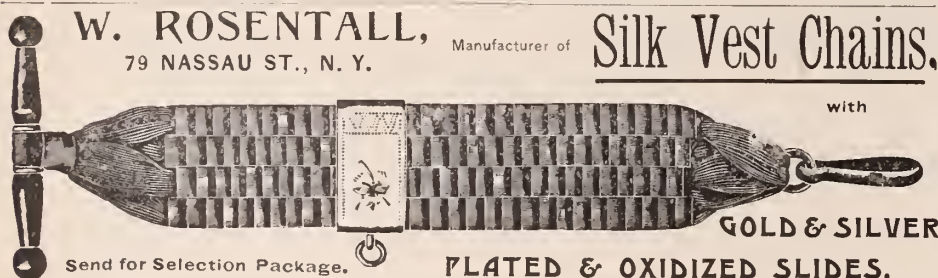

with

GOLD & SILVER
PLATED & OXIDIZED SLIDES.

Send for Selection Package.



JOHN A. RILEY & SLOAN Co.,
860 Broadway, New York.

MAKERS OF

HAIR PINS, HAT PINS,

TIARAS, BROOCHES,

SCARF PINS, NECKLACES, ETC.

Rosaries & Crucifixes, Chatelaines.

Our line includes both 14k. Gold and Sterling Silver.

T. B. BYNNER,
Dealer in

Diamonds, Opals, Pearls,
AND EVERY VARIETY OF PRECIOUS STONES,
in varied and novel combinations.

177 BROADWAY, NEW YORK.

WIGGERS & FROELICK,
60 NASSAU ST., NEW YORK,
Sample Cases and Trays
For Watches, Jewelry, Optical Goods, Etc.

WE STRIVE TO MAKE THE BEST

ALVIN MFG. CO.,
* SILVERSMITHS, *
860 Broadway, New York.
206 Kearney St., San Francisco.
Factory, NEWARK, N. J.

N. A. Salmon, of Le Boutillier & Co., 17 Murray St., New York, departed last Thursday on a two months' trip, to secure orders for the firm's line of Hammersley, Royal Worcester, Doulton, Adderley, Crown Derby, and other fine potteries of which they carry extensive lines.

Herman Keck Mfg. Co., Cincinnati, O., received last week from the South a very fine and curious set of jewelry to repair. It is about seventy-five years old. The pin is two inches long, of Roman gold, with a center piece of coral, representing a tulip an inch long, with tiny gold stamens. The wide chain bracelet has the same design.

Last May the United States Optical Co., 15 Grand River Ave., Detroit, Mich., were organized to manufacture optical goods in all branches. The officers, as follows, are well known and successful business men: President, August Rasch; Vice-President, Eugene Deimel; Secretary and Treasurer, F. A. Rasch; manager, H. H. Gray. On the first floor of the establishment are the offices, store and shipping-room with a full and large stock of their own manufactured and direct imported goods. The second floor is used for manufacturing cases of every description. On the top floor is situated the manufacturing department, equipped with the latest and most improved machinery. Here spectacles and eye glasses in all their branches are made. A specialty of the company is a fine line of gold spectacles and eye glasses of the latest patterns. Another to which especial attention is devoted is prescription orders. Physicians will find it to their advantage to place this kind of work under Mr. Gray's supervision. The company employ only salaried men as traveling salesmen. Their first year's business has been unexpectedly successful and with strict and honorable dealings with their patrons, they anticipate building up a business that will be a credit to Detroit.

KREMENTZ & Co.,
182 & 184 Broadway, NEW YORK,

MANUFACTURERS OF

GOLD JEWELRY,

14-K. BEAD NECKLACES,

— AND —

KREMENTZ ONE-PIECE COLLAR BUTTONS.

LEON J. GLAENZER & CO.,

80 CHAMBERS STREET

35 Boulevard de Strasburg,
PARIS.

NEW YORK.

OUR SPECIALTIES:

Clocks, Porcelains, Faiences, Bronzes

We have now on exhibition and are constantly receiving large shipments of the latest novelties in **Onyx and Marble Clocks**, with Gilt and Enamelled Trimmings, **Regulators, Traveling Clocks, Porcelain and Gilt Mounted Clock Sets, Vases, Candelabras, etc.**, which we are offering at Lowest Prices.

Our stock also comprises a large assortment of **Porcelains, Faiences, Bronzes, Gilt and Silver Photo Frames, Jewel Boxes, Bonbonnières, Mirrors, etc.**, suitable for the jewelry trade.

SPECIAL INDUCEMENTS ON IMPORT ORDERS.

THE WASHINGTON CITY SOUVENIR SPOON.

THE ONLY NATIONAL SPOON PRODUCED.

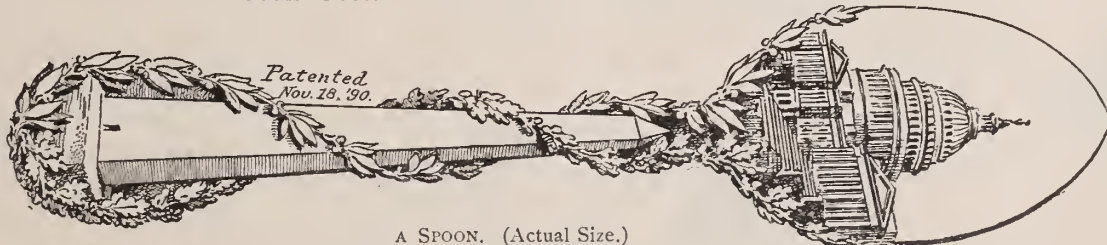

A SPOON. (Actual Size.)



COFFEE SPOON. (Actual Size.)

PHENOMENAL SUCCESS.

The Best Seller of them all.

MADE IN STERLING SILVER ONLY.

Coffee, Orange and Tea Sizes; also Paper Cutters, Bonbon Spoons, Etc., Etc.

LIBERAL DISCOUNT TO THE TRADE.

SEND FOR DESCRIPTIVE CIRCULARS AND PRICES.

MOORE & LEDING, 1109 Penn. Ave., Washington, D. C.



The Remington Standard

has set the copy for writing machines for 15 years. It is to-day the

Standard

and expects in the future, as it has in the past, to lead all others in adding improvements to what will always be the true model of a

Typewriter.

W. J. Koff, Seamans & Benedict,
327 Broadway, New York.

G. F. FEINIER,
MANUFACTURER OF
WATCH CASES,
Repairing of Every Description,
NO. 9 BOND STREET, NEW YORK.
Key-Wind Cases Altered to Stem-Wind, and made same as New. English Cases Altered to take American Movements

Jules Jürgensen
OF COPENHAGEN.

The reputation these watches have maintained for **Fifty Years** has never been equaled, being made on strictly scientific principles, and no expense spared to give the **Best** results in mechanism and timekeeping qualities.

SOLE AGENTS,
John C. Hyde's Sons,
NO. 22 MAIDEN LANE.

H. H. HEINRICH,
12, 14 & 16 John St., New York.
Manufacturer of
MARINE CHRONOMETERS.

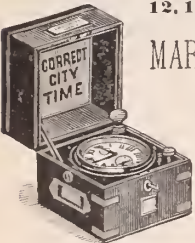

Silver Medal, Paris Exhibition, 1889.
A large stock of new and second-hand Marine Chronometers on hand. All my second-hand Chronometers are thoroughly overhauled, refinished and re-adjusted. Rented out at \$5.00 per month, payable in advance. No rent charged if bought within a certain time. Terms to suit customers. Marine Chronometers repaired and adjusted for the trade.

SWARTCHILD & CO.,



Our Complete Catalogue, illustrated, will be sent to any one forwarding us their address, free of charge.

We give special attention to mail orders. They are filled promptly the same day that they are received.

76 and 78 State Street, Chicago.

Chicago College of Horology,

SUCCESSORS TO
THE CHICAGO HOROLOGICAL INSTITUTE,

IS ACKNOWLEDGED by those who have investigated the subject to be a

FIRST-CLASS INSTITUTION,

Where those who desire to learn the art of WATCH MAKING and ENGRAVING can obtain the

BEST PRACTICAL INSTRUCTION.

New features are continually being added. It is the aim of those conducting the management of the College to make it the

BEST INSTITUTION of the kind IN THE COUNTRY.

C. R. HART, General Superintendent,

CHICAGO COLLEGE OF HOROLOGY,

CHICAGO, ILL.

WRITE FOR PROSPECTUS.

VACHERON & CONSTANTIN,
GENEVA, SWITZERLAND.



FINEST QUALITY OF WATCH MOVEMENTS, FITTING ALL SIZES OF AMERICAN CASES.

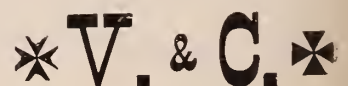

CHAS. LEO ABRY,

Agent for the United States and Canada.

41 and 43 Maiden Lane, - - - NEW YORK.

Brief History of Gold and Silversmithing.

(Continued from page 43, March 25.)

PART VI.
PROCESSES.

LET us now very briefly examine the chief processes which have been used in silversmithing during the last fifty years. It is understood that we only consider those of one branch, hollow wares.

Lathe work has almost entirely replaced hammering, and the technical word *retreig-neur*, applied in France to artisans who shape a metal vessel entirely by hand, simply using various hammers together with anvils and tools stuck in a wooden block, may only, at present be claimed by a few. The advantages of lathe work are sufficiently numerous to permit us to overlook its short-comings.

A turned silver vessel is bound to be well proportioned, dense and even. It is almost entirely free from those flaws which occasionally spoil the best works made by hammering. On the other hand, the machine process does not allow, at least to a sufficient extent, the forcing up of the metal to the rim of the piece so as to give to that part the thickness required.

When, on the lathe, a thin goblet has been brought to its intended height, the artisan turns the brim over and forms a kind of hem, which, if properly made, gives a strong appearance to the top part and consequently to the whole piece. This is all very well, to obtain a deceptive result; but when it is desired to make a massive silver vessel, the rim, which must always be thicker than the other parts of the piece, so as to preserve the given shape, has to be reinforced with a band prepared for the purpose. This band is soldered on the border of the piece, and then turned on the lathe, in a way calculated to incorporate it, so to speak, with the vessel. A skilful turner soon transforms the patch into an elegant moulding.

I need not describe the lathe. I dare say a lengthy article enumerating the various improvements gradually added to that rather ancient machine, would be very interesting.

To make of one piece the body of a vessel, say a coffee-pot, the top of which is to be narrower than the bottom, several forms or mandrels are required, and the last of the series must consist of separated parts assembled around a nucleus. A circular silver plaque of the size and thickness wanted is first placed on a slightly hollow mandrel, fig. 1, which is screwed on the lathe and maintained on it by a sliding cone. Then the lathe is set in motion, and a tool whose top has the shape of a flat ball, fig. 2, is applied on the plaque, which is gradually forced into the hollow until it fits throughout. This is obtained by moving the tool from the rim to the center and back, as many times as necessary. The rough vessel has to be pulled out and repeatedly submitted to annealing. It is next applied on a half spherical mandrel, and kept in a central position by means of a hollow piece of wood, whose bottom part of steel is maintained in the right horizontal

TOWLE MFG. CO.,

MANUFACTURERS OF



Sterling Silverware



NEWBURYPORT, MASS.: 214 MERRIMACK ST.

CHICAGO:

SAN FRANCISCO:

149 & 151 STATE ST.

220 SUTTER ST.

ESTABLISHED 1873.

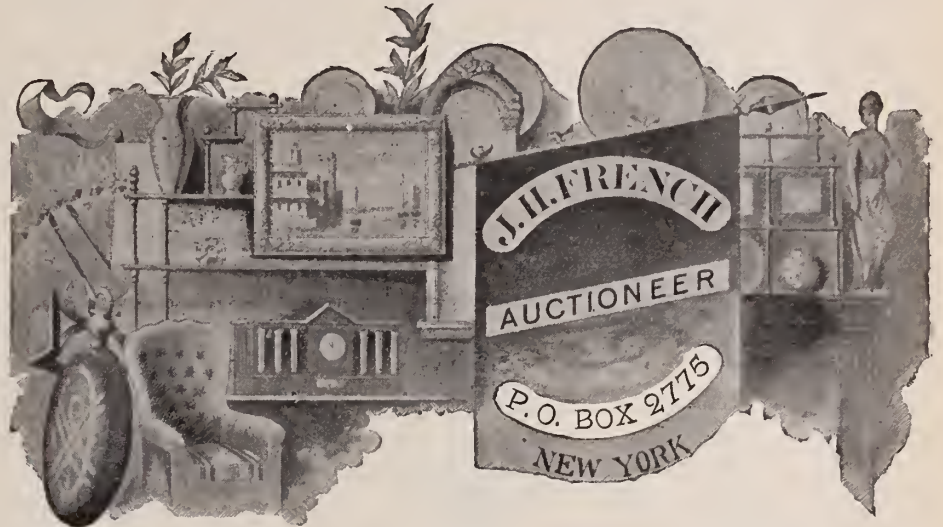

If for any reason you should desire the services of an AUCTIONEER, and will write me as to the amount of stock you have on hand and its general character, the size of your store and the number of inhabitants of your town or city, I could, from my extended experience, give you an idea of the amount of business you could expect under the circumstances, and, no doubt, be able to refer you to some one for whom I have sold under conditions similar to your own.

As a general reference, you could hardly find a wholesale jeweler who is not familiar with some of the numerous successful sales I have made.

I have made many successful AUCTION SALES, and have yet to record a failure to fully satisfy the owners. Can give you hundreds of references to that effect.

If the business should be urgent and I am myself engaged, I have two competent assistants instructed in my methods whom I could send on short notice.

Any correspondence with me will be strictly confidential in every case.
P. O. Box 2775.

NEW YORK CITY.

JOHN SCHEIDIG & CO.
IMPORTERS AND MANUFACTURERS OF

OPTICAL



GOODS

43 MAIDEN LANE, NEW YORK.

A FULL line of Gold, Steel and Aluminum American Spectacles and Eye Glasses of latest and special designs. Imported and American Lenses. We also control the following brands of OPERA AND MARINE GLASSES: La Favorite, Colmont, Lemaire, College d'Optique.

SEND FOR
ILLUSTRATED CATALOGUE.

LEMAIRE OPERA GLASSES.

line by the sliding cone. For that second stage of the work and the following ones, a polished tool, apparently in the shape of a spoon, fig. 3, but really convex on one side and flat on the other, is used by the silversmith, who moves it underneath the piece, from right to left and *vice versa*, thus gradually manages to draw the silver vessel over the half spherical form.

The piece is now applied and stretched, in turn, over two cylindrical mandrels. Finally it is fashioned on the one (fig. 4,) which is meant to give the intended shape, viz.: the mandrel consisting of several pieces (of an even quantity, four, six or more) assembled around a nucleus, fig. 5. I think that the plain figures 6 and 7 sufficiently illustrate what I mean.

When the body of the coffee pot is obtained, the mandrel is unscrewed from the lathe; then the nucleus being pulled out, the broken pieces fall together and can easily be shaken out. Our fig. 8 shows the series of forms that must be used in order to bring a silver vessel, which is to have a curved outline to assume its right shape.

Of course I do not mean to deal here with exceptional cases, yet, I may say that a skill-

ful silversmith often manages, through *trick-ing*, to fashion goblets, ewers, and coffee pots of an awkward shape, exceedingly narrow at the top, which appear to an average artisan to be impossible to execute, of one piece, on a lathe.

Mohammed's seventh heaven, the celestial gates fly ajar,—untold numbers of beautiful houries, chanting psalms, precipitate themselves toward you, and the charming alarm clock begins its ravishing strain, "Fly to my arms, love," etc., ah, "where is the man with soul so dead" who would hustle out of bed, rush on his "duds," swallow his cup of muddy chickory and tough beef-steak, and contentedly trot to his office or workshop? How different this musical alarm clock from the cracked, unmodulated voice of the "gentle master" of the writer's apprenticeship, which was wont to woo him from sleep to life and activity with, "get out o' there, you lazy loafer, or I'll throw a basinful of cold water

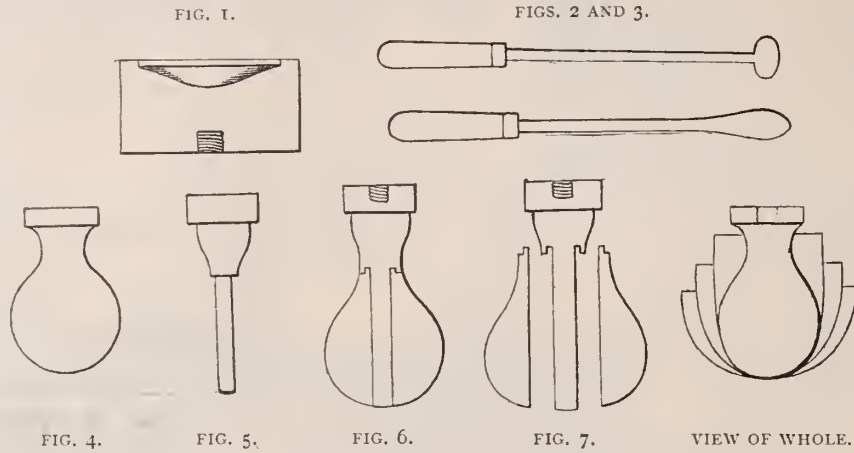

Musical Alarm Clocks.

THIS age has often been stigmatized for its want of poetry, and is therefore called "the materialistic age;" with how little reason, the invention described in the following, to wit a musical alarm clock, will palpably demonstrate. Think of this, ye lovers of the matutinal repose, when in your rosy sleep the brightest of dreams has with its pinions of aurora transported you into

on you!" But, "The years crept slowly by, Lorena."

The watch manufacturer, Ed. Margot-Peyrot, of Moudan, Switzerland, has devised a musical alarm clock which happily combines the beautiful with the practical. The alarm rattles off at a designated time and unlocks the musical work, as will be seen from accompanying cut and description. The alarm barrel is designated by A., the tooth rim of which depths into the pinion of

H. A. WADSWORTH & CO.

MANUFACTURERS OF

GOLD · FILLED · WATCH · CASES,

NEWPORT, KY.

the scapewheel B., which causes in the known manner the hammer M. to strike on bell C.

The lower part of the alarm clock contains a small musical work. It is regulated in the customary manner by the locking lever *i*, which is pressed by the spiral-shaped spring *j*¹, fastened to the fly bridge, with its projection *i*, against the outer face of the barrel wheel, until the piece of music is ended, after which the projection *i* of the locking lever obeys the pressure of the spring *j*¹, and drops into a notch in the barrel-wheel; the arm *i*¹, of the locking lever *j*, stopping the fly.

In order to unlock the musical work, therefore, the projection is to be raised out of the notch in the barrel wheel. This is effected by a mechanism described as follows: Between the alarm work and the musical work is located on the inner side of the front side of the clock case the two-armed unlocking lever E, which rotates around a stop screw F, the upper end of the unlocking lever E lies against the barrel A. To one of the sides of the case is screwed a long pipe, which serves as guide

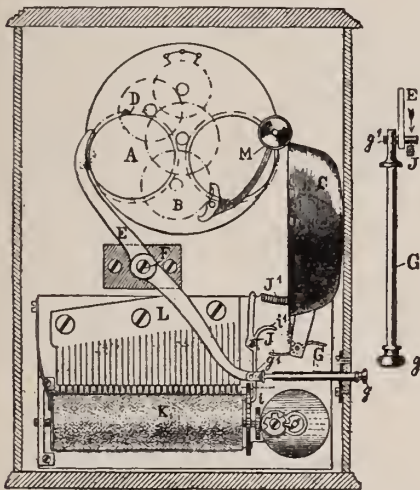

to the unlocking rod G. At the end of this rod G, protruding outside of the case is a button *g*, while its inner end is connected with the lower end of the unlocking lever E, by means of a pin, *g*¹, which is lengthened out toward the front side of the case, so that it reaches behind the locking lever *j*. For sake of a better understanding, the rod G with its afore-mentioned parts is shown separately; the view is from above, as seen from the cover of the case. An unlocking of the musical part, therefore, takes place when the rod G with the pin *g*¹ is displaced in the direction of the arrow.

This displacement, now, is effected by the projection D on the circumference of the alarm barrel. When the alarm works begin to act at the designated time, the projection D slides during the revolution of the barrel A part under the curved upper end of the unlocking lever E, whereby the pin *g*¹ unlocks the locking lever *j*. The musical work begins to play as soon as the rattling of the alarm has ceased.

In spite of the great simplicity, the unlocking is thoroughly secure; the musical work is entirely independent of the going or alarm

THE BOWDEN Seamless Plain Ring,

IS MADE ONLY BY

J. B. BOWDEN & CO.,

Makers of FINGER RINGS of every Description,

COR. BROADWAY & JOHN STREET,
NEW YORK.

A. WITTNAUER,

30 Maiden Lane, New York,

MAKER OF

COMPLICATED * WATCHES.

TIMING WATCHES

OF ALL STYLES.



SPLIT SECONDS

AND

Minute Repeaters.

VARIOUS GRADES, ALL ACCURATELY MADE.

Also Sole Agent for the Celebrated LONGINES & AGASSIZ Watches.



NEW YORK OFFICE,

PRESCOTT BUILDING,
ROOM 40 SAMPLES ONLY.

WORKS, BLACKSTONE & GAY STS.
TAKE PRAIRIE AVE CAR

Providence, R.I.

works of the clock, so that it can be made to play at any time by drawing out the button. The idea of listening to a charming piece of music while breaking the ice in the ewer for performing the matutinal ablution, is decidedly original, and should be patented in all civilized countries, as it is already in Switzerland.

The Depthing ool.

A DEPTHING tool is an indispensable auxiliary to the repairer, and it should be the best that can be made. There are many of these tools made and sold that are worse than useless, as if the distance between the centres do not coincide at each successive point, at which they may be moved outward, it will be impossible to pitch a depth correctly with them; in other words, the centres as runners should be parallel to each other, whatever the size of the wheel and pinion may be that is being adjusted in them. When purchasing a new depthing tool, great care is necessary. The centres should be turned end for end and transposed, ascertaining after each change if there is any deviation in a circle described by the points; also if the points when they meet coincide exactly. If possible, a comparison should be made with an approved tool by trying in both a large and also a small wheel and pinion. The adjusting screw had better be removed so as to see that the joints work smoothly and that the spring has perfect control over it. If the joint is stiff and appears

to be dirty, the joint pin may be taken out and the joint thoroughly cleaned.

But however correct the tool may be, it requires practice and skill to use it properly, as, when the wheel and pinion are removed from the tool, and the depth has to be transferred to the plate, if the depthing tool is not held at right angle to the plate, but is inclined either to the right or left, the depth will be either deeper or shallower than it was seen while in the tool. Care should also be taken not to screw the nuts up too tight, as it is quite possible to spring the runner a little from the way in which it is gripped; in fact, a watchmaker should not be a strong man, otherwise he will make many difficulties for himself by exercising his muscular strength.

The Action of the Balance.

THE force of the balance in revolving winds up the reciprocating spring, and as soon as this spring has secreted all the force of the balance, the motion is reciprocated by the uncoiling of the spring. Arrived at the place of the escapement arc (where the lever is lying at the proper angle against one of banking pins), the jewel pin of the roller enters the lever notch, and the reciprocated force of the balance, by the aid of the roller pin, now moves around the lever and pallets sufficiently to draw the locking out from under the escape wheel tooth, and all the mechanism then being set free, the escape wheel moves forward again over the impulse

plane of the opposite pallet, giving another impulse to the pieces, and again another tooth of the wheel drops on to the opposite locking, the wheel resting there and stopping all the machinery while the roller and balance vibrate freely as before.

Proportions of Silver to Gold.

AS far as figures are obtainable, the relative value of silver to gold has never been so small as at the present time. The following are some of the authentic proportions known:

Time of Abraham.....	I to 8
B. C. 1000.....	I " 12
" 500.....	I " 13
Commencement Christian Era I	" 9
A. D. 500.....	I " 18
" 1000.....	I " 8
" 1400.....	I " 11
" 1545.....	I " 6
" 1551.....	I " 2
" 1600.....	I " 10
" 1727.....	I " 13
" 1800 until 1872.....	I " 15 1/2
" 1876.....	I " 20

From the last date, for some years, silver gradually depreciated in value, and then advanced, until on Aug. 1, 1886, the proportion reached the highest point for the last half century, and then declined again to 1 to 20. On the basis of the present Silver Coinage Law, Congress is attempting to raise the proportion to 1 to 16.

WE DESIRE to call your attention to our large and varied assortment of

Complicated, High Grade Gentlemen's and Ladies'



In Gold Cases, both Plain and Enameled, in Choice Designs.

THE LARGEST STOCK EVER SHOWN IN THIS COUNTRY.

NON-MAGNETIC WATCH CO.

OF AMERICA.

CHAS. McCULLOH, RECEIVER

177 Broadway. - - NEW YORK.

AIKIN, LAMBERT & Co.,

23 Maiden Lane,

NEW YORK,

Manufacturers and Exporters of

Fine Gold Pens, Pencils,

TOOTH PICKS, HOLDERS,
And Novelties in Silver, Pearl, &c.



THE BEST FOUNTAIN PENS.

New Assortments in SHOW CASES and FANCY TRAYS for JEWELERS.
Price Lists and Catalogues for intending Purchasers.



Also American and Swiss Watches.

DIAMONDS, Loose and Mounted,

Gold and Silver Thimbles,

CHAINS and JEWELRY in New and Staple Patterns.

A. RICKERT. C.A. STIEHLE.

RICKERT & STIEHLE,

MANUFACTURERS OF

GOLD CHAINS,

SWIVELS AND SPRING RINGS.

Chain Repairing a Specialty.

13 & 15 Franklin Street. NEWARK, N. J.

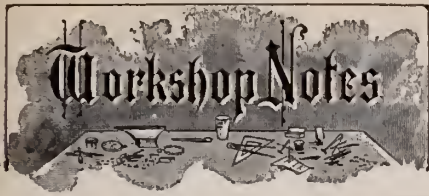

Cleaning Gold Frames.—Gilt frames may be cleaned by applying heated alcohol, with a sponge, until all stains are effaced. The alcohol is then allowed to dry off gradually. Under no circumstances dry with a cloth.

Fire-Proof Cement.—A very tenacious and fire-proof cement for metals is said to be made by mixing pulverized asbestos with water glass, to be had at any drug store; it is said to be steam-tight and resist any temperature.

German Silver.—An excellent German silver is prepared by smelting in a crucible 55 parts copper, 23 nickel, 17 zinc, 3 iron, and 5 tin. This composition is in every respect equal to silver in appearance, fully as hard, and is not vitreous.

Gold-colored Lacquer.—The following is a good receipt for a lacquer that will put a gold color on a copper-plated work. One gallon methylic alcohol, ten ounces of bruised seed lac, and one-half ounce of red saunders wood; dissolve and strain.

To Solder Broken Broaches.—Steel broaches and other tools are soldered by cleaning well the parts broken, then dipping them into a solution of sulphate of copper, and soldering them with ordinary soft solder. The joint is a good one and will stand ordinary hard wear.

Acid-proof Cement.—A cement that resists acid is made by melting 1 part India rubber with 2 parts linseed oil; add sufficient white bolus for consistency. Neither muriatic nor nitrate acid attack it; it softens a little in heat, and its surface does not dry easily; this is corrected by adding ½ part litharge.

A New Alloy.—A new alloy, known in Germany as Nuremberg gold, is at present frequently employed for the manufacture of cheap gold ware, and is well suited to the purpose; since, as far as its color is concerned, it is absolutely similar to that of pure gold, nor is it in any manner influenced by a continual exposure to air. The alloy will retain its color even after violent use, and the fracture exhibits the pure gold color. Its composition is as follows: copper, 18; gold, 2½; aluminum, 7½.

Transparent Cement.—Ordinary cements generally leave yellowish traces which look disagreeable, especially with transparent objects. The following recipe makes a perfectly colorless varnish: 7½ grams India rubber, cut into small pieces, are thrown into 60 grams chloroform, in an air-tight closing bottle. When the rubber has been dissolved thoroughly, 15 grams mastic are added and digested for about eight days, until dissolved. The cement prepared in this manner is used like any other.

DIAMONDS.
Wm. S. Hedges & Co.,
 Importers of Diamonds,
 And Manufacturers of DIAMOND JEWELRY.
 No. 170 BROADWAY,
 S. E. Cor. Maiden Lane, } New York.
 27 Holborn Viaduct, London.



“ S ”
 A “NOVELTY” in Marquis Rings.
 ASK YOUR JOBBER FOR
STERN BROTHERS’ DIAMOND MOUNTINGS,
 42 MAIDEN LANE, N. Y.

MAXHEIMER & BERESFORD,
 MANUFACTURERS OF
FINE DIAMOND JEWELRY,
 No. 3 Maiden Lane, New York.
 ORDER WORK A SPECIALTY.

TO THE TRADE ONLY.
 Balance Staffs, - 60 Cents.
 Inserting Pivots, 40 Cents.
 ALL OTHER WORK IN PROPORTION.
 SEND FOR PRICE LIST.
THOMAS JUZEK & CO.,
 ELGIN, ILL.

WILL REMOVE APRIL 15, TO
 189 BROADWAY.

R. A. Kipling
 Importer of Precious Stones

31, Union Square New-York 19, Rue Drouot Paris

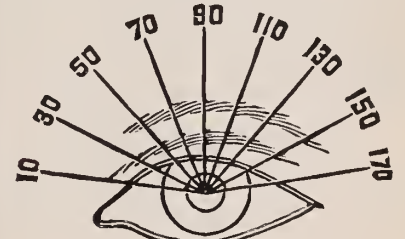

SEND TO
GENEVA OPTICAL CO.
 23 Washington St., Chicago.
 FOR PRESCRIPTIONS, REPAIR AND ORDER WORK
 PROMPTLY AT LOWEST PRICES.

SEXTON BROS. & WASHBURN,
 41 MAIDEN LANE, NEW YORK,
 MANUFACTURERS OF
FINE JEWELRY,
 INCLUDING A FULL LINE OF MOUNTINGS.



PROMPT AND CAREFUL ATTENTION GIVEN TO SPECIAL ORDER WORK.

A. N. CLARK, PLAINVILLE, } MANUFACTURER of the Celebrated
 CONN. }
LOOP WATCH KEY.



The best for the price in the World. Size of Square stamped on each Key.

Also Key Rings, Watch Case Springs, Jewelry Tools, Tweezers, Etc.

SEND FOR PRICE LIST. * SOLD BY ALL JOBBERS IN THE LINE AT MANUFACTURER'S PRICES.

BURDON'S · SEAMLESS.

THE ORIGINAL
And only Genuine



AND
Perfect Seamless Filled Wires
IN THE WORLD.
Sold to all Manufactur-
ers alike.

Burdon Seamless Wire.

TRADE-MARK.

The success of the BURDON SEAMLESS FILLED WIRE, like that of all important inventions, has been followed by deceptive and imperfect imitations. For the protection of

ALL JOBBERS AND RETAILERS,

we authorize manufacturers who so desire, to affix upon the tag, card or label accompanying the articles made from this wire, this registered trade-mark owned by this Company.

The bird-on-wire is a guarantee that the goods are made from the original Burdon Seamless Filled Wire, the reputation of which has been firmly established among the best dealers for more than two years. The perfection and qualities of the Burdon Seamless Wires are always guaranteed. All Dealers (jobbers and retailers alike) should, therefore, demand goods made from the original Burdon Wire, and avoid imitations which are offered as "just as good."

BURDON SEAMLESS FILLED WIRE CO.,
109 to 119 and 127 Summer Street,
PROVIDENCE, R. I.

TELL A. BEGUELIN,
IMPORTER OF
WATCHES,

Watch Materials, Tools and Glasses,
No. 71 NASSAU STREET,
(UP STAIRS.) NEW YORK.
Cor. John Street, NEW YORK.

Sole Importer of Material for the
"Bijou," "Victor," "Boston," "Bristol,"
"Adelphia," "Jockey Club," "Wallingford,"
"Cesar," "Lady Racine" and "New Haven"
Watches

Selling Agent for materials for LONGINES
and AGASSIZ Watches.

AMERICAN WATCHES,
ALSO STEM WIND WHEELS

Importer of Full Line of Swiss Watches,
AND FRENCH CLOCK GLASSES.

S. COTTLE & CO.,
MAKERS OF

FINE JEWELRY AND SILVER
NOVELTIES,
No. 86o Broadway, NEW YORK.

ARTIFICIAL EYES!

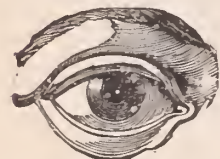

STOCK ORDERS of
Selection Packages.

Largest Assortment.

GENEVA OPTICAL CO.,
23 Washington St., Chicago.

R. & L. FRIEDLANDER,

Wholesale Jewelers,

AND

JOBBERS IN AMERICAN WATCHES,

Tools, Materials and Optical Goods,

65 & 67 NASSAU STREET, N. Y.

Factory, 50 BOND STREET.

Send Business Card and we will mail you our Watch and Jewelry Catalogue,
No. 12, and our Tool, Material and Optical Catalogue, No. 14.

READ THIS LETTER:

HENRY ERBSMEHL,

Watchmaker & Jeweler,

Watches, Clocks, Jewelry and Silverware.

MILFORD, DEL., March 4th, 1891.

MESSRS. R. & L. FRIEDLANDER, New York City.

GENTLEMEN: It gives me pleasure to recommend to the trade your Monarch Main Springs, for American Watches. They are, without exception, the best Main Springs that I have ever used. I have tried all makes within the last 25 years, but have found none equal to the Monarch Springs. They are uniform in force and temper; out of 6 dozen springs, I have lost but two.

I remain, yours truly,

HENRY ERBSMEHL.

Try our Monarch American Main Springs, \$12.00 PER GROSS.
\$1.00 PER DOZEN
POSITIVELY NO GOODS SOLD AT RETAIL.

Established 1872.

PLAINVILLE STOCK CO.

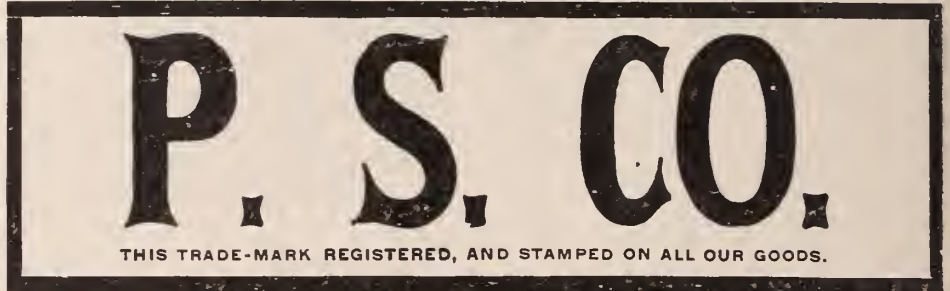

BROOCHES, SCARF PINS, DROPS, SETS.
FACTORY AT PLAINVILLE, MASS. SAMPLES AT 176 BROADWAY, NEW YORK

DIAMOND SETTINGS. GALLERIES. HOLLOW BALLS, ETC.

BLANCARD & CO.,

36 & 38 JOHN STREET,

SEND FOR OUR NEW YORK. CATALOGUE.

MUSICAL JACOT & SON,
298 Broadway,
New York

Send for Catalogue. **BOXES.**
Musical Boxes Repaired.

THE WALTHAM SCHOOL OF HOROLOGY,
D. D. PALMER, Teacher and Proprietor.

Best Advantages in the Country for Horological Instruction.

All branches under the personal supervision of D. D. PALMER, for a number of years in charge of the Adjusting Department of the Waltham Watch Co. POSITIONS GUARANTEED TO APT PUPILS. For terms and other particulars, address

D. D. PALMER,
WALTHAM, MASS.
Specialty of Difficult Repair Jobs.

GILBERT T. WOGLOM,

BLACK ONYX
JEWELRY. GOLD MOUNTED.
32 & 34 John St. New York City.



Recent Patents

Issue of March 24, 1891.

DESIGN 20,591. HANDLE FOR SPOONS, ETC., WILLIAM B. DURGIN, Concord, N. H.—Application filed February 18, 1891. Serial No. 381,972. Term of patent seven years.

DESIGNS 20,594 and 20,595. HANDLE FOR SPOONS, ETC. LOUIS R. HORTON, Providence, R. I., assignor to J. B. & S. M. Knowles, same place.—Applications filed February 5, 1891. Serial Nos. 380,359 and 380,360. Term of patents seven years.

DESIGN 20,625. HANDLE FOR SPOONS, ETC. FREDERICK H. SLOAN, Hartford, Conn.—Application filed January 22, 1891. Serial No. 378,702. Term of patent seven years.

DESIGN 20,636. SPOON, ETC. CHARLES OSBORNE, New York, N. Y., assignor to The Whiting Manufacturing Company, same place.—Application filed December 26, 1890. Serial No. 375,905. Term of patent three and a half years.

TRADE MARK 19,221. SPOONS, FORKS, AND ARTICLES KNOWN AS FLAT WARE. H. M. HILL & Co., Lynn, Mass.—Application filed February 24, 1891. Used since February 16, 1891. "The words 'Dungeon Rock.'"

TRADE MARK 19,222. SPOONS, FORKS, AND ARTICLES KNOWN AS FLAT WARE. L. KIMBALL & SON, Haverhill, Mass.—Application filed February 14, 1891. Used since January 28, 1891. "The representation of the statue or figure of the Hannah Duston monument."

448,712. ELECTRIC TIME-ALARM. JOHN J. GALLAGHER, St. Louis, Me.—Filed November 28, 1890. Serial No. 372,901. (No model.)

448,734. MACHINE FOR ENAMELLING SMALL DIALS. THOMAS F. SHERIDAN, Springfield, Ill.—Filed March 3, 1890. Serial No. 342,498. (No model.)

448,892. FINGER-RING. CHRISTOPH STAIGER, Brooklyn, N. Y.—Filed May 10, 1890. Serial No. 351,282. (Model.)

This ring is formed of two separable ring-shaped members A, and B., the member A. having an elongated loop a, while the other member has a rectangularly-bent arm b, extending at right angles, or

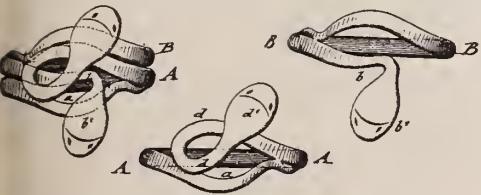

nearly so, to the plane of the ring-shaped portion of the member, the bent arm having an enlarged head, which is passed through the loop of the first member, so as to interlock therewith.

448,877. STEM WINDING AND SETTING WATCH. ALBERT CHOPARD, Moutier-Grandval, Switzerland, assignor to the Société Industrielle, same place.—Filed October 23, 1890. Serial No. 369,159. (No model.) Patented in Switzerland March 13, 1890, No. 1,970.

The combination, in a stem-winding watch, with the stem having a notch of a pivoted lever, having a pin for engaging the notch, a pivot stem, permanently secured at one end to the lever and passing through and movable longitudinally in the watch-plates, and a spring engaging the movable stem for maintaining the stem and lever in engagement.

OPPENHEIMER BROS. & VEITH, Diamonds, Watches and Jewelry, 2 Tulp Straat, 35 Maiden Lane, AMSTERDAM. NEW YORK.

We beg to inform the trade that we are still in a position to fill orders for

✂ DUEBER HAMPDEN WATCHES ✂

Of all grades, from stock purchased previous to the closing of the factories at Canton.

HAYDEN W. WHEELER & CO., 2 MAIDEN LANE, NEW YORK,

Have an unusually large and varied stock of

FANCY STONE RINGS,

CONSISTING OF

MOONSTONE, GARNET, TOPAZ, AMETHYST, PERIDOT,
PEARL, DOUBLET, SARDONYX,

And the various combinations of these Stones.

DIAMONDS, ✂ WATCHES, ✂ JEWELRY.

WANTED, AN ADVERTISEMENT.

I will pay Fifty Dollars in cash to the Retail Jeweler who shall prepare the best worded and most effectively displayed advertisement of *Abbott's Patent Stem-Winding Attachment*, suitable for use in Magazines and Newspapers that reach the general public.

The advertisement to occupy a space of not more than two inches high by five inches wide.

The contest will close May 1st, 1891, and the prize will be awarded within ten days from that date.

**I WILL PAY
FIFTY
DOLLARS
IN CASH**

The following gentlemen will act as judges:

Mr. L. J. MULFORD,
Of The Jewelers' Circular.

Mr. ALBERT ULMANN,
Of The Jewelers' Weekly.

Mr. JOHN L. SHEPHERD,
Of The Keystone.

Circulars and descriptive matter supplied on application.

HENRY ABBOTT,

After May 1st, 14 Maiden Lane.

4 Maiden Lane, N. Y.

448,930. STOP-WATCH. ROBERT BRAGGE, Aston, England.—Filed July 26, 1890. Serial No. 360,329. (No model.) Patented in England February 22, 1890, No. 2,856, and in Switzerland April 9, 1890, No. 2,009.

In stop-watches, the combination of the push-piece *a*, working upon a fulcrum *c*, and having a tail-piece

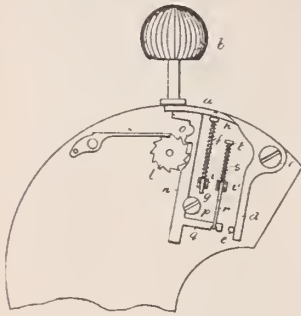

d operating against a stop-piece *e*, with the sliding pawl-bar *n* and ratchet wheel *l*.

448,896. JEWEL-SUPPORT FOR BALANCE-STAFFS OF WATCHES. JULES VILLOX, Lima,

Peru.—Filed February 13, 1890. Serial No. 340,268. (No model.)

In a watch-movement, the combination, with the compensation-balance and its staff, of the socketed jewels receiving the pivots of the staff, the settings containing the jewels and provided with beveled peripheries, the supports having circular recesses which present annular seats on which the beveled peripheries bear, and springs arranged to hold the settings on their seats with a yielding pressure.

448,998. INDEPENDENT ELECTRIC CLOCK. WILLIAM S. SCALES, Everett, assignor of two-thirds to Joseph H. Clark, Quincy, and John B. Humphrey, Boston, Mass.—Filed July 19, 1890. Serial No. 359,304. (No model.)

448,999. SECONDARY ELECTRIC CLOCK. WILLIAM S. SCALES, Everett, assignor of two-thirds to Joseph H. Clark, Quincy, and John B. Humphrey, Boston, Mass.—Filed October 20, 1890. Serial No. 368,672. (No model.)

449,016. PENDULUM ADJUSTMENT FOR CLOCKS. FRANK M. WAKEMAN, Nantucket, Mass.—Filed October 21, 1890. Serial No. 368,796. (No model.)

In a pendulum-adjuster, the combination, with the pendulum-rod, of a pivoted suspension arm having a

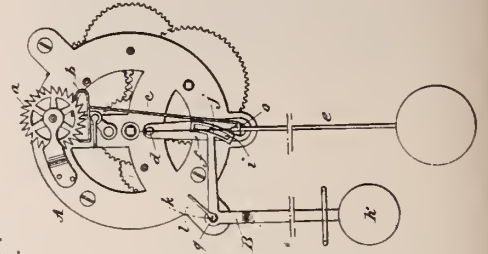

stud projecting from the face thereof, and an angled weighted lever provided with a slotted cam.

Paper weight clocks are exhibited everywhere in Paris. Some makers of these articles have reduced their size to such an extent that they look like mere trinkets. This gave to an eccentric nobleman the idea of wearing a tiny clock hanging from a double chain. That minuscule time-piece, square in shape, is in chased gold and enamel.

WATERBURY CLOCK CO., CLOCK MANUFACTURERS.

SALESROOMS:
10 Cortlandt St., New York,
GEO. M. VAN DEVENTER AGENT.

SALESROOMS:
114 & 116 Wabash Avenue,
CHICAGO,
CHARLES J. DODGSHUN, Agent.

SALESROOMS:
528 & 530 Market Street,
SAN FRANCISCO.
A. I. HALL & SON, AGENTS.

FACTORIES:
Waterbury, Conn.

123 Stockwell Street, Glasgow,
T. R. DENNISON, AGENT.

Essex Watch Case
COMPANY,

T. B. HAGSTOZ, President.

TRADE MARK

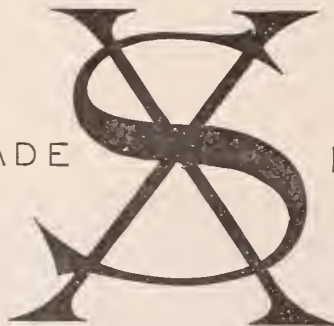

GOLD FILLED CASES.

6 Maiden Lane, N. Y.

OFFICE,

NEWARK, N. J.
FACTORY,

ESTABLISHED 1837.

TAYLOR & BROTHER,

OLD HOUSE READ, TAYLOR & CO.

IMPORTERS OF

DIAMONDS and PRECIOUS STONES,

CLOCKS AND BRONZES,

860 Broadway, cor. 17th Street, N. Y.

Branch Office for Clocks and Bronzes,

1½ MAIDEN LANE N. Y.



ROGERS & BRO. A-1.

OLDEST BRAND AND HIGHEST GRADE OF

ELECTRO SILVER PLATE.

ROGERS & BROTHER, Manufacturers,

16 Cortlandt Street, New York.

Waterbury, Conn.



HOLLOW WARE.

Price Lists upon Application accompanied by Business Card.

Interesting Table Concerning Escapements.

THE following interesting table concerning the time-keeping qualities of the different principal escapements, as tested in the Cantonal Observatory of Neuchâtel, Switzerland has been compiled by Dr. Hirsh, the observer in charge:

DAILY VARIATION, ARRANGED ACCORDING TO THE KIND OF ESCAPEMENT.

YEARS.	Anchor.	Pivoted Detent.	Chronometer.	Tourbillon.	Annual Average.
	Secs.	Secs.	Secs.	Secs.	Secs.
1862.....	1.51	1.80	2.01	2.30	1.61
1863.....	1.39	1.28	1.37	0.64	1.28
1864.....	1.14	1.47	1.17	0.66	1.27
1865.....	0.81	1.01	0.70	0.42	0.88
1866.....	0.67	0.73	1.01	0.35	0.74
1867.....	0.70	0.61	0.74	0.52	0.66
1868.....	0.57	0.56	0.66	0.29	0.57
1869.....	0.61	0.58	0.60	0.55	0.60
1870.....	0.53	0.62	0.52	0.40	0.54
1871.....	0.56	0.53	0.47	0.56	0.55
1872.....	0.53	0.46	0.54	0.58	0.52
1873.....	0.62	0.63	0.56	0.72	0.62
1874.....	0.54	0.52	0.48	0.60	0.53
1875.....	0.46	0.47	0.17	0.49	0.46
1876.....	0.54	0.53	0.53	0.24	0.53
1877.....	0.51	0.59	0.25	0.52	0.51
1878.....	0.62	0.56	0.32	0.58	0.60
1879.....	0.66	0.59	0.22	0.35	0.61
1880.....	0.50	0.51	0.28	—	0.49
1881.....	0.53	0.55	0.25	0.38	0.32
1882.....	0.52	0.66	0.78	0.43	0.55
1883.....	0.56	0.50	0.43	0.35	0.54
1884.....	0.60	0.55	0.21	0.33	0.58
1885.....	0.57	0.57	0.38	0.39	0.57
1886.....	0.51	0.51	0.22	0.29	0.50
1887.....	0.52	0.57	0.33	0.32	0.52
1888.....	0.52	0.54	0.20	0.42	0.50
Mean variation during the 27 years from 1862-1888.	0.567	0.637	0.531	0.561	0.580

Without entering into further details, it will be seen that the rates of watches have been improved most wonderfully during the past fifteen years, and that the anchor, detached lever, this maid-of-all-works, worthily rank with its more aristocratic brother, the pivoted detent, and also with the tourbillon, were it not for the careful execution of the latter. Considering the roughness of its usage, there is not an escapement rivalling the detached lever.

A One-Minute Talk on Souvenir Spoons.

A BANCROFT-WORCESTER SOUVENIR.

THE PREVAILING FASHION of chronicling historic events, and perpetuating the memory of celebrated personages, in the form of souvenir spoons, gives Worcester the opportunity of utilizing for this purpose an event of which her citizens may justly be proud.

October third, of the year eighteen hundred, gave to the nation one who was destined to rank as the foremost historian of the United States. A man whom the heart of the commonwealth delights to honor as one of her most illustrious sons, and whose birthplace still stands to commemorate the event.

A few weeks previous to the death of the Hon. GEORGE BANCROFT, a design for a Spoon decoration was prepared by Mr. H. B. Swart, of the BURBANK Jewelry Firm, representing in Sterling Silver a fine portrait-medallion of this eminent son of Worcester, together with a fac-simile, in relief, of his birthplace, the old Bancroft homestead now standing on SALISBURY STREET, in this city.

The design was placed with the Silversmith for execution, and the work has been artistically done. These Souvenir Spoons are of the regular teaspoon size, bearing on the front of the handle the medallion, and on the reverse the representation of the homestead with this inscription:—

“Birthplace of GEORGE BANCROFT, Worcester, Mass.”

The recent death of the distinguished subject lends an additional appropriateness to this local tribute at this time. We wish also to add that the designs are patented, and the dies can be used on a variety of other table silver if desired.

WORCESTER BANCROFT SOUVENIR SPOONS.

PRICE LIST.

Tea Spoon, - - - - -	\$2.50	Pap Spoon, Gold Bowl, - - -	\$4.00
“ Gold Bowl, - - - - -	3.00	Sugar Spoon, - - - - -	3.50
Orange Spoon, - - - - -	3.00	“ Gold Bowl, - - - - -	4.00
“ Gold Bowl, - - - - -	3.50	Butter Knife, - - - - -	4.00
Pap Spoon, - - - - -	3.50		

THIS PATTERN IS MADE ONLY BY

A. F. BURBANK, Jeweler,

Cor. Main and Exchange Sts., Worcester, Mass.

DESIGNS PATENTED MARCH 31, 1891.

Any of the above will be sent by mail, prepaid, on receipt of price.

GOOD DISCOUNT TO THE TRADE.



EXAMPLES OF CLASS PINS (PLATE 26, COPYRIGHT 1891), DESIGNED AND MADE BY HENRY C. HASKELL, 11 JOHN ST., NEW YORK. PLATES SENT TO DEALERS UPON REQUEST.

MATHEY BROS., MATHEZ & CO.

16 MAIDEN LANE, N.Y., AND BRASSUS, SWITZERLAND,

MANUFACTURERS AND IMPORTERS OF

Plain and Non-Magnetic Movements.

Complicated Watches a Specialty.

**CHRONOGRAPHS,
MINUTE REPEATERS,
AND
SPLIT SECONDS,**

IN ALL GRADES AND SIZES.

SOLE AGENTS FOR

H. L. Matile, C. H. Meylan and J. J. Badollet. Watches Demagnetized.



REPEATERS



CHRONOGRAPHS.

THE **RYDER & DEARTH** DESIGNERS & ENGRAVERS

Fine Commercial and Copper-Plate Printers.

A Specialty of

Jewelers' Printing, Cuts and Electrotypes.

Headquarters for JEWELERS' CARDS.

BEST WORK,

PROMPT DELIVERY,

LOW PRICES.

No Order Too Large! None Too Small!

146 Westminster Street,

PROVIDENCE. - RHODE ISLAND.



JOHN B. YATES,

No. 147 NASSAU STREET, NEW YORK.

WATCHES

SPECIALTIES: UNITED STATES WATCHES.



I have a limited number of Discontinued American Waltham Gilt Hunting, price formerly \$12.65, same grade as the "Taylor" (Elgin) Movement, for \$10.50 Net.



ZIP!



Revolve these Rings in your mind, and you cannot help thinking of **OSTBY & BARTON**, the well known ring makers. 80 Clifford Street, Providence, Rhode Island.

The next table, due to the same source is even of greater interest.

DAILY MEAN VARIATION, ACCORDING TO BALANCE SPRING USED.

	1888.		1871.		1888.	
	Daily Mean Variations.	Ascertained from Chronometers.	Daily Mean Variations.	Ascertained from Chronometers.	Daily Mean Variations.	Ascertained from Chronometers.
Flat spring with Philippe's terminal curve.....	± 0.48	114	± 0.55	2755		
Flat spring with two Phillips' terminal curves....	0.51	16	0.49	384		
Phillips' cylindrical spring.....	0.52	0	0.45	228		
Phillips' cylindrical spring, with two terminal curves..	0.20	8	0.29	11		
Mean of Phillips' springs.....	± 0.47	147	± 0.53	3378		
Brequet springs....	± 0.59	54	± 0.54	613		
Ordinary cylindrical spring.....	0.53	55	0.57	257		
Ordinary spherical (bale) spring.....	0.55	6	0.52	68		
Mean of ordinary springs.....	± 0.55	115	± 0.57	938		
Mean of all watches	± 0.505	262	± 0.54	4316		

Watch Screws.

ONE of the important things which a good repairer should understand is that of making a screw. There are more good watches spoiled from repairers trying to use screws that can be bought ready made, and that are quite unsuited to the uses to which they are put, than from almost any other cause; and the fallacy is in thinking that, by using the screws, time is saved (that is, if the repairer can make a screw). Let us presume that the repairer has a good stock of screws of all kinds and makes on hand, and that almost every screw in the watch has become overturned; of course, the hole will have to be retapped, and the thread or pitch of your bangle screws will certainly not be the same as that of your tap; but suppose you get over that by forcing one in the hole, the head of the screw has to be fitted to the sink. If the head be sunk, it will be either too high or too low, the tap will not be the right length, and the time spent in shortening the screw and chucking it to fit the head to the sink, or reducing the height of the head, will be quite as much as it would take any tolerable workman to make a screw that would be, in all respects, equal to the original. In the case of jewel and screws, the objections to using ready-made screws is even greater, as these screws are usually, and of necessity, placed so close to the sink, from the hole and settings, that a screw even a shade larger than the original one would often burst the hole into the sink; and although the variety in the size of the taps of jewel screws is not so great as that of other screws of the watch, it is often necessary to make a jewel screw when the hole is already so large that it will scarcely bear to be tapped again.

N. KOCH. L. DREYFUS. J. KOCH. I. PFORZHEIMER.

KOCH & DREYFUS,

22 John Street, New York.

IMPORTERS OF DIAMONDS,

JOBBERS OF

AMERICAN WATCHES,

Diamond Novelties and Jewelry

We have now a complete line of Goods and Specialties on hand and on the road in charge of following representatives:

JONAS KOCH, GEO. MALLET, L. GOLDSMITH,
HENRY HEYMAN, A. ROSENTHAL.

LOUIS NEWMAN, JR.

GOLD AND SILVER

Plater, Fire Gilder and Colorer.

Gilding by a New Process. Watch Cases, Jewelry and Novelties, Work stands acids, and in finish equal to Gold. 36 & 38 JOHN STREET, NEW YORK.

TO THE TRADE. FINE WATCH REPAIRING

BY JOHN C. SIMMONDS,

18 JOHN STREET, NEW YORK.

New pieces, such as Chronometer Locking Springs, Balance Staffs, &c., made in the best styles. Watches sprung and adjusted to temperature and positions.

NEW SHAPE.

NEW CUT.

WATER BOTTLE.

Can be seen at the

CUT-GLASS SHOWROOM OF

T. B. CLARK & Co.,

53 PARK PLACE,

NEW YORK.

WELDED CHROME STEEL AND IRON

5 PLY.

FOR BUILDING



Jewelers' Safes, Vaults, Etc.

Positively Burglar Proof, cannot be Cut, Sawed or Drilled. OUR TRADE MARK is stamped on all our goods and we caution purchasers to avoid imitations. We are the sole manufacturers of genuine Chrome Steel in the United States.

CHROME STEEL WORKS,

Kent Avenue, Keap and Hooper Sts., Brooklyn, N. Y.

S. H. KOHN, PRES. C. P. HAUGHIAN, VICE-PRES. J. G. DUNSCOMB, Sec

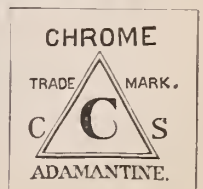

A Complete History of Watch and Clock Making in America.

BY CHAS. S. CROSSMAN.
Number Fifty-three.

Continued from page 40, March 18.
SILAS HOADLEY.

ALTHOUGH not attaining to quite the prominence of some of his contemporaries as a clock maker, yet Silas Hoadley may certainly be classed among the prominent makers of his time. His birthplace was at the Grist Mill House, Bethany Society, New Haven County, Conn., the event taking place Jan. 31st, 1786.

He served an apprenticeship at carpentering with Calvin Hoadley, and when Eli Terry purchased the old grist mill in 1807, which was afterward the clock factory, the young man entered the employ of Mr. Terry as a

journeyman, working on the old style of wooden clock. Seth Thomas also came there as a workman, and in 1811 Messrs. Thomas and Hoadley bought out Mr. Terry, and ran the business in their own names. They continued together until 1813, when Mr. Hoadley purchased his partner's interest in the business for \$4,000, the latter removing to Plymouth Hollow, and carried on the business alone. At the time the Terry shelf clock came into popularity, Hoadley made them for some time, but subsequently he got up a shelf clock which he called his own. He took for a basis the Terry shelf clock, turned it bottom side up and made some alterations in its general appearance, and called it Hoadley's shelf clock. Probably the reason for this was that he had had some misunderstanding with Mr. Terry.

The business grew steadily under Mr. Hoadley's management. Fifteen to twenty

workman were now employed and the production reached some 25,000 clocks per year, which, until the advent of the New England Railroad, he sent by wagon to Hartford and New Haven to be shipped. That part of the town where Mr. Hoadley was located was then called the Ireland District, but after the railroad was built the name was changed to Hoadleyville, which it still retains.

He continued the manufacture of wood shelf clocks until the era of brass clocks, when he too commenced to manufacture them in 1842, having his son Milo with him as the more active man in the firm. They carried on the business until 1845, when it was closed up as being unprofitable. The factory was subsequently used as a pocket-cutlery factory.

Mr. Hoadley, who had obtained a fair competence for that time, continued to reside in Hoadleyville until his death in 1870. He

BIPPART & CO.,

Newark, N. J.



INTERIOR VIEWS OF
FACTORY.



Manufacturers of

FINE JEWELRY.

was a man of genial disposition, and was universally beloved by those who knew him. As expressive of his mild disposition, he was often called "Blue-eyed Hoadley" by those who knew him.

SAMUEL AND LUTHER HOADLEY, AND RILEY WHITING.

Samuel Hoadley went to Winsted from Waterbury in 1807, where he had been in the employ of James Harrison, the clockmaker. He purchased the land and water privileges which are the present site of the Wm. L. Gilbert Clock Co.'s factory in Winsted. His brother Luther was also interested with him. They erected a saw and grist mill, and later a wool-carding mill. In 1809 Riley Whiting, of Winchester, married their sister, and as he had some experience in wooden clock-making he was taken into the firm, and that industry was added to the other enterprises of the Hoadley brothers.

Luther Hoadley died in 1813, and Samuel removed to Ohio in 1822, at which time the grist mill and saw mill business was discontinued, and Mr. Whiting was left the entire possession of the clockmaking business, and carried it on quite extensively until his death in 1835, at which time that part of the town had come to be called Whitingville. He went to Illinois to make some collections and was taken suddenly ill while there, and died in a few days. After Mr. Whiting's death the buildings remained unoccupied until 1842, when they and the site were purchased by L. Clark, Ezra Baldwin, and W. L. Gilbert, who started brass clockmaking. Messrs. Clark and Baldwin dying, the firm became Gilbert & Woodruff, and subsequently the Wm. L. Gilbert Clock Company, of which we will speak elsewhere.

Massive gold rings of various patterns are much worn in Paris now. The most conspicuous represent a serpent or a lizard queerly curled; some are in cable-work; many have the shape of a neck tie, with an emerald in the center of the bow-knot. I have seen one showing a cupid's head with wings stretching back circularly. Some imitate wicker-basket work, with a succession of pale gold parts and bluish oxidized ones; others which are faceted are incrustated with diamonds and rubies.

THE "LONGFELLOW" SOUVENIR

A FAITHFUL LIKENESS.

FROM THE BIRTHPLACE OF THE POET, PORTLAND, ME.

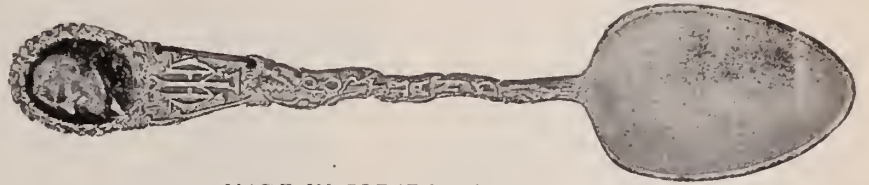

MADE IN COFFEE AND TEA SIZES.

Will find a ready sale among the multitudes in our great country who loved the poet and still love his works.

Send for Circulars and Prices to

J. A. MERRILL & CO.,

239 Middle Street,

PORTLAND, ME.

DISCOUNT TO THE TRADE.

BOOK * MARKS

IN
STERLING SILVER,

FRANK H. LA PIERRE,

No. 18 East 14th St., New York

NEW GOODS.

STERLING SILVER.

Spring Novelties.

LEWIS BROTHERS,

41 Maiden Lane, NEW YORK.

A COMPLETE

LINE OF

Mounted

GOODS

Constantly

ON

HAND.

ESTABLISHED 1841.

CARTER, SLOAN & CO.

MANUFACTURERS OF

FINE JEWELRY,

15 MAIDEN LANE,

NEW YORK.

A. CARTER, JR.
A. K. SLOAN,
C. E. HASTINGS,
GEO. R. HOWE,
WM. T. CARTER.



Factory, NEWARK, N. J.

The Other Side of Life.

KNOWLES—Wedding rings are not much sold any more.

BOWLES—How's that?

KNOWLES—The fact that poets are born, not made, has proven that marriage is a failure.

MERCHANT—Why did you leave your last position?

APPLICANT—I pilfered some of the stock, and was discharged.

MERCHANT—Eh? Well, I suppose I must take you, else people will say I'm a Tartar, and stood in the way of your reformation.

HE WAS AS SMART AS SHE.

FLEDGELY.—Now, Miss Scott, that Lent is over, I would like to get my presents to you back.

ALICE.—Avec plaisir.

FLEDGELY.—And the interest of \$500, the amount I paid for them, for the past month is \$2.50. I would like to have that too.

WASTING LIFE.

PONSONBY—You look very lugubrious, old man.

POPINJAY—I feel so, dear Pon. My life is ebbing away. This watch loses a minute a day, which will amount to over seventeen days in seventy years.



PROF. Poddinkopf—What has happened to make you laugh so much, young ladies?'

MISS SWEETCHILD—Alice Kittenly said—he, he!—your face would stop a clock. He, he!

PROF. Poddinkopf.—If Miss Kittenly paid more attention to her natural philosophy, she would learn that that is entirely beyond physical possibility.

A SPRINGTIME DEFINITION.

LITTLE ALECK—Popper, what's an April fool?

POPPER—An April fool, my son, is a young man who on the first warm day puts up his overcoat to take out his watch.

A ROUSING PRESENT.

1ST PARTNER—Old Jellyby reaches his half-century's service in this house to-day.

Don't you think we ought to give him something?

2D PARTNER—Yes, give him a nice alarm-clock.

SUFFICIENT CAUSE, INDEED.

CHIDWIDLER—Why is Jingleby's wife so jealous of him?

HOMSOEVER—You know he's an optician, and he has eyes for everyone.

COLUMBUS WATCH CO.,



No. 97. Open Face.

Discontinues
Movements

Nos. 27 AND 97.



No. 27. Hunting.

THESE are full Jeweled with extra large Center Jewel. Finely adjusted and just the thing for railway service. There are only a few of these movements on hand, and as they will be sold at a price that will move them QUICKLY, ask your jobber for them in time.

COLUMBUS WATCH CO.,

COLUMBUS, OHIO.

N. J. FELIX,

(ESTABLISHED 1865.)

MANUFACTURER OF
GOLD and SILVER WATCH CASES,

ROOMS 6, 7 AND 8,
71 Nassau St., New York.



BEFORE—FRONT VIEW.

Old English Cases altered to Stem-Winding; also to Imitation Stem-Winding with key attachment to crown. Bezels altered to take flat glasses.

SEND FOR PRICE LIST.



AFTER.



BEFORE—BACK VIEW.

Orders or jobs sent me by mail or express always receive prompt and careful attention. As for references where he is not known, Mr. Felix can confidently state that he has done work continuously for the last twenty-five years for the very best houses in New York.

FIGURES TALK.

6,000 PAIRS DAILY of Spectacles and Eye Glasses are sent out by the

SPENCER OPTICAL MFG. CO.

MAKING A GRAND TOTAL OF

1,800,000 PAIRS ANNUALLY.

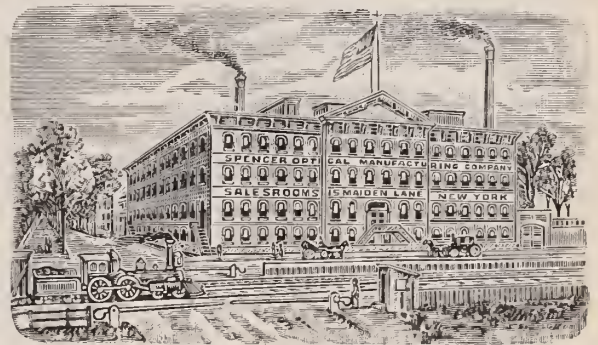

The reason is that the trade are realizing that it is to their advantage to deal directly with the manufacturers. We advertise no cut prices. All our prices are lower or as low as the lowest, when quality is considered. Our Catalogues and Price-List are free.

OPERA GLASSES

Of new designs and styles are already being prepared for the fall trade of 1891. Send in your orders and have name engraved on eye-piece. Our

OPERA GLASS HOLDERS

Are a great success, and customers are sending holders of other makes to be exchanged for our improved "grip."

A HARD CASE

To excel is the "Audemair" Occulists' Trial Case. 15 styles at 15 prices; from \$36.00 to \$100.00. You should see it before purchasing.

ANYTHING PERTAINING TO VISION

Can be obtained of us.

THE SPENCER OPTICAL MFG. COMPANY,

MANUFACTURING OPTICIANS.

15 MAIDEN LANE, N. Y.



B. & W. B. SMITH,

220 West 29th Street, New York City.

Stores, offices, etc., fitted entire or nearly so, by B. & W. B. SMITH.

- | | |
|---|---|
| Spaulding & Co., Chicago, Ill. | Frank D. Barnum, Louisville, Ky. |
| J. R. Watts & Co., Atlanta, Ga. | Bailey, Banks & Biddle, Philadelphia, Pa. |
| Simons Bros., Columbus, Ohio. | Sigler Bros. & Co., Cleveland, Ohio. |
| W. H. Mortimer, Pottsville, Pa. | P. L. Miles & Co., Cleveland, Ohio. |
| C. W. Hoffman, Latrobe, Pa. | W. W. Wattles, Pittsburg, Pa. |
| C. L. Mercereau, Scranton, Pa. | Cowell & Hubbard, Cleveland, Ohio. |
| Harris & Shafer, Washington, D. C. | J. B. Storer, Akron, Ohio. |
| Francis Miller, Washington, D. C. | J. S. McDonald, Baltimore, Md. |
| Wm. Dempsey, Washington, D. C. | Justis & Armiger, Baltimore, Md. |
| J. W. Drew, Washington, D. C. | Hennegen, Bates & Co., Baltimore, Md. |
| M. W. Galt, Bro. & Co., Washington, D. C. | Welsh & Bro., Cleveland, Ohio. |
| M. W. Shaw, Galveston, Texas. | C. F. & L. Uhl, Cleveland, Ohio. |
| Bigelow, Kennard & Co., Boston, Mass. | M. Scooler & Co., New Orleans, La. |
| Tilden, Thurber & Co., Providence, R. I. | C. F. Klein & Co., San Antonio, Tex. |
| Warner & Parker, Bridgeport, Conn. | F. W. Sim, Troy, N. Y. |
| Geo. H. Ford, New Haven, Conn. | Marsh & Hoffman, Albany, N. Y. |
| C. J. Monson, New Haven, Conn. | F. M. Bonnett, Columbus, Ohio. |
| J. E. Bullard, Middletown, Conn. | Joseph Seymour, Sons & Co., Syracuse, N. Y. |
| Gaven, Spence & Co., Newark, N. J. | Chas. H. Schiller, Utica, N. Y. |
| M. D. McCown, New Orleans, La. | C. C. Shaver, Utica, N. Y. |
| Harrison Robbins, Philadelphia, Pa. | C. R. Smith & Son, Philadelphia, Pa. |
| Carrington, Thomas & Co., Charleston, S. C. | J. Wetherell & Son, Parkersburg, W. Va. |
| J. P. Stevens & Co., Atlanta, Ga. | Gus. E. Smith, Parkersburg, W. Va. |
| Freeman & Crankshaw, Atlanta, Ga. | Wood, Bicknell & Potter, Providence, R. I. |
| Myers & Finch, St. Paul, Minn. | I. G. Dillon & Co., Wheeling, W. Va. |
| J. W. Curtis, Warsaw, Ind. | W. Beveredge, Washington, D. C. |
| J. R. Worth, Hempstead, L. I. | Brunner Bros., Cleveland, Ohio. |
| Bunde & Upmeyer, Milwaukee, Wis. | J. E. Caldwell & Co., Philadelphia, Pa. |
| Jas. Montgomery & Bro., Los Angeles, Cal. | Diener Y. Rothacker, Mexico City. |
| Yeatts & Troth, Philadelphia, Pa. | Hugh Glenn & Co., Utica, N. Y. |
| M. S. Smith & Co., Detroit, Mich. | Daniel Low, Salem, Mass. |
| C. L. Byrd & Co., Memphis, Tenn. | Philips & Armitage, Jamestown, N. Y. |
| Duhme & Co., Cincinnati, Ohio. | A. & J. Plaut, Cincinnati, Ohio. |
| Clemens Hellebush, Cincinnati, Ohio. | Russell, Philadelphia, Pa. |
| Chas. J. Steinau, Cincinnati, Ohio. | C. G. Rochat & Co., Jersey City. |
| | Smithsonian Institute, Washington, D. C. |
| | Veeder & Son, Schenectady, N. Y. |

COMPARE ALL OTHER GOLD FILLED CASES WITH THE CELEBRATED CROWN LION EXPANSOR H. MUIR'S SONS HAND ENGRAVED CASES



S. P. HOWARD,
 Gold and Silver Assayer,
 Refiner and Sweep Smelter,
 8 & 10 JOHN STREET, NEW YORK.
 Smelting and Refining Works,
 28, 30 & 32 Cumberland St., Brooklyn, N. Y.
 Specialties: Sweepings, Gold, Silver and Platinum.



NEW! NATTY!! NOX-ALL!!!
Signal Eyelet Stud
 PATENTED
 OPEN. NOX-ALL STUD. CLOSED.
 Made in Gold, Silver, Gold Fronts and Rolled Plate. Easily adjusted. "Send for Approval Packages."

J. A. FLOMERFELT & CO.,
 MANUFACTURING JEWELERS,
 177 & 179 Broadway, - New York.
 Branch Offices: 178 Monroe Street Chicago.
 100 Palace Hotel San Francisco.

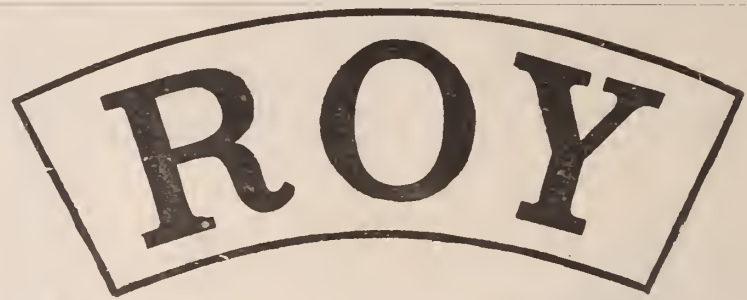

PLATINUM SCRAPS MELTED. BOUGHT AND SOLD.
ROBERTSON & LEBER,
 Gold, Silver and Platinum Refiners,
 13 & 15 FRANKLIN ST., NEWARK, N. J.

S. F. MYERS & CO., Wholesale Jewelers.

EVERYTHING THAT PERTAINS TO THE JEWELRY DEPARTMENTS.



WE REQUIRE AND OCCUPY THE LARGEST SALESROOMS IN OUR LINE. 4 STORES. GROUND FLOOR.

48 & 50 Maiden Lane and 33 & 35 Liberty Street, New York.
 CONSULT OUR MAMMOTH CATALOGUES.

REMOVAL. GUNZBURGER BROTHERS, Importers of Diamonds FROM 25 TO 35 MAIDEN LANE.

CIRCULATION
 FEBRUARY, 40,150
 MARCH, - 40,155

SOUVENIR SPOON SERIES
 NO. 3.

LARGEST CIRCULATION
 OF ALL THE
 JEWELRY JOURNALS.



Entered at the Post Office in New York as second-class matter.

VOL. XXII.

NEW YORK, WEDNESDAY, APRIL 8, 1891.

No. 10.

SOUVENIR SPOONS.

PART III.

THERE is no city in the Union which presents to the thoughtful and patriotic American, so many features of interest as does Washington. This feeling is intensified by the fact of its having been located

distinction as to attract the attention of General Washington. He was assisted in the work by the advice and suggestions of Thomas Jefferson. In designing a plan for the city, it is evident that the predominating

ment Washington is in many respects the handsomest city on both sides of the Atlantic.

Everyone who has not visited the royal



WASHINGTON CITY.

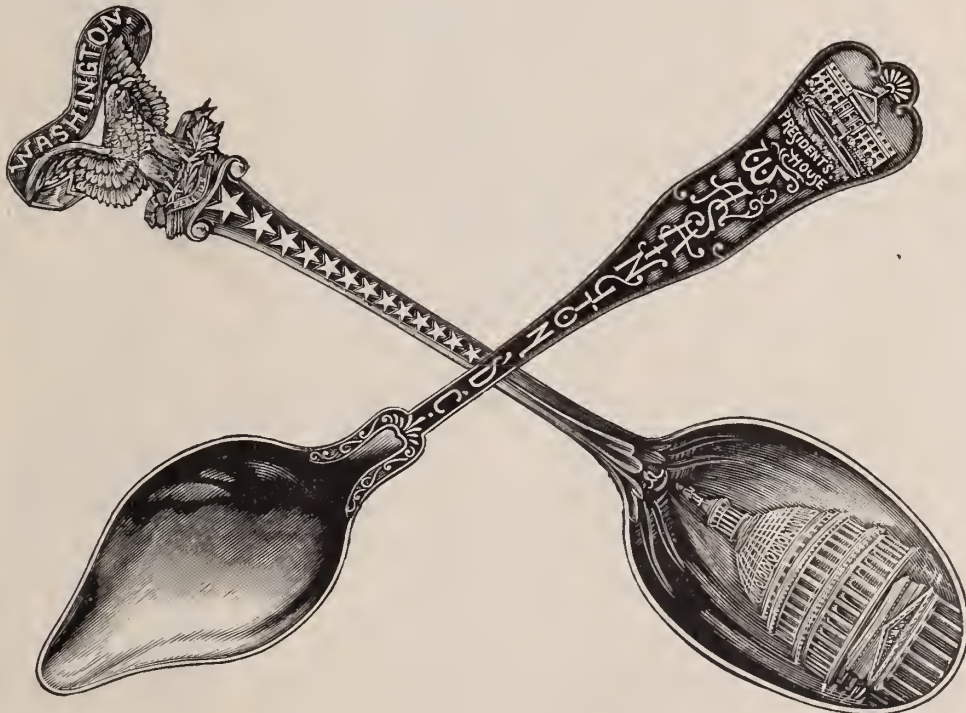

THE EAGLE WASHINGTON AND THE WHITE HOUSE.



MT. VERNON,
 MOORE & LEDING.

and founded by the great, immortal personage whose illustrious name it bears. A plan of the city was prepared in 1791, by Peter L'Enfant, a French engineer, who had served in the continental army with such

object was to secure the most eligible situations for the different public buildings, and to arrange the squares so that the most extended views might be obtained from every direction. Through this arrange-

city of the Kings of France, Versailles, has, in his own mind, ascribed to that city the most delicate beauties, and in his mind's eye he has seen the city resplendant in gilt decoration; in fact it has appeared to

him as some fairy home. That this is not so, needs no emphasis. But travelers say that the city is bright, clean and handsome; they recognize the resemblance between the plans of that city and Washington. The grand avenues, de Sceaux and St. Cloud are reproduced in Pennsylvania and Maryland Aves. The broad thoroughfares of the American city are among its principal attractions, and are undoubtedly the finest possessed by any city in the world.



THE MOUNT VERNON,
HARRIS & SHAFER.



PIERCED WORK,
PHILADELPHIA.

It is not too bold an assertion to make, that Washington is the most visited city in the country, with perhaps one exception, New York. It is the Mecca of every seeker after pleasure, knowledge, curiosity or idleness. Thither will Miss Rooney and a certain surnameless Joe tie themselves after the marriage ceremony; they will go, because thousands, yes, hundreds of thousands, of newly-joined couples have done so before, thinking that the world outside Washington was too small for the requirements of their honeymoon. Thither go the young man with a group of languishing sisters, one as a sort of a chaperone, the others to have their languor dispelled. Thither wend their way, Abigail and Abijah Hayseed, of narrow life and narrower views. Thither the delegates of misapprehended citizens of almost unconceived dugout-villes, bloated with importance on their entrance into the city and squeezed to gaspipe rotundity upon their departure. Thither every commercial salesman of New York, who travels anywhere beyond Newark and Brooklyn. Thither the regular army of society puppets.

Through the halls and rooms of the Capitol, the National Library, the Hall of Representatives, the President's House, Departments of State, War and Navy, the Bureau of

Engraving and Printing, the Patent-office, the General Post-office, Naval Observatory, the Medical Museum, Smithsonian Institute, National Museum, Corcoran Art Gallery, and numerous other structures, the great army of visitors make their way, impressed or *ennuied* with what they see, and many thinking that upon their return to their homes they will look back upon their visit with delight, feel that they should take away with them some memento that will ever enable them to retain the sentiment.

It is not surprising, therefore, when we take all the circumstances above referred to into consideration, that Washington is very fruitful in designs of souvenir spoons. As stated in the first part of these series, the fashion in America was practically started in that city; two of the principal houses in the city, M. W. Galt, Bro. & Co., and Moore & Leding, claim the precedence, and each has grounds on which to base its claims, the details of which it is hardly necessary to go into here. Up to the present writing there are ten Washington spoons on the market or about to be placed on the market.

THE EAGLE WASHINGTON.

The emblemata in this spoon, as seen in the illustration, are particularly appropriate. The handle is composed of a succession of thirteen stars of graduated sizes, representing the original States. At the head of the handle is an eagle in full relief, above which furls a ribbon containing the word, Washington; in the claws of the king of birds is a narrow ribbon disclosing the nation's motto, *E pluribus Unum*. Stamped in the bowl is a representation of the dome of the capital. This dome, which is visible from every elevated point in the District for miles around, and from the windows of which is extended a panorama of wooded hills, beautiful valleys, etc., ranks fifth in height with the greatest structures of the kind in Europe. It was designed by Walter to replace the original one removed in 1856. The apex is surmounted by a lantern fifty feet high, surrounded by a peristyle, and crowned by a bronze statue of Freedom. In the spoon the excellent workmanship has brought out all the details of the structure to perfection. This spoon, which is owned and manufactured by the Gorham Mfg. Co. can scarcely be considered an article of utility, but as an artistic memento it is especially adapted. The front of the spoon is oxidized, while the back of the bowl is bright finished. Harris & Shafer control the spoon in Washington.

MOORE & LEDING'S WASHINGTON.

South of the President's house, stands the National Monument to the Father of his country, designed by Mills. It was completed December 6, 1884. The idea of this monument took definite shape in 1833. In 1847 the popular subscriptions amounted to \$87,000, and with this sum the work was commenced. The total pressure of the foundation of the mass as it now stands is 80,378 tons. The monument is a marble obelisk, whose shaft from the floor is 555½

feet high; the foundation is 36¾ feet deep, making an aggregate height of 592 feet, one of the loftiest works of ancient or modern times. The total cost of the structure has been \$1,130,000. A miniature of this monument, with a vine of laurel twining around it from top to bottom, forms the handle of the spoon designed and controlled by Moore & Leding, Washington, D. C. The illustration is but an outline drawing, and scarcely does justice to the beauty and character of the design. Within the bowl is a view of the dome and front of the Capitol. The excellent workmanship and the attractive design of the spoon warrant all the popularity it has. It is one of the best selling spoons produced.

THE WHITE HOUSE.

As seen from the illustration the outlines of the White House spoon, patented and sold by Harris & Shafer, Washington, D. C., are very graceful, delicate and original. The design of the exterior of the handle though simple, is exceedingly effective. At the top is a representation of the White House, situated in the western part of Washington, about one and one-half miles from the Capitol. The building, originally erected in 1792, has passed through several vicissitudes. At present it is built of free stone, is one hundred and seventy feet in length and eighty-six feet in width. The house among other things contains full length portraits of both George and Martha Washington. The details of the building are accurately reproduced in the spoon, the fountain and shrubbery being perfectly depicted. Below this, in small letters are the words President's House, and arranged perpendicularly down the remainder of the handle are the letters of the words, Washington, D. C., uniquely designed. The front of the handle



THE GLOVERVILLE.

down the remainder of the handle are the letters of the words, Washington, D. C., uniquely designed. The front of the handle

TRADE

SEAMLESS

MARK.

GOLD · FILLED · CHAINS.

ON ACCOUNT OF

THE great popularity of the chains made exclusively by us for the past three years, the air has been FILLED and the paper of the various Jewelers' Journals COVERED with the word "SEAMLESS" which has been and is our trade mark.

We never had such a boom in our business as we have had since our friends commenced to advertise our goods.

We have only a word to add, and that is we make and sell the

ORIGINAL AND GENUINE

SEAMLESS GOLD FILLED CHAINS.

In addition to the word SEAMLESS and for the protection of our customers we place upon each Chain a tag bearing the following trade-mark:



Which is affixed by authority of its owners, as a guarantee that the Chains are made from the Burdon Seamless Filled Wire.

BOSTON OFFICE,
6 WINTER STREET,
In charge of
I. W. STELLE.

NEW YORK OFFICE,
17 Maiden Lane.

PACIFIC COAST AGENCY,
WM. E. PETTES & CO.,
PHELAN BUILDING,
SAN FRANCISCO, CAL.

Address all communications to

KENT & STANLEY,

PROVIDENCE, R. I.

SOLID SILVER

EXCLUSIVELY.



WHITING MFG. CO.

Silversmiths,

UNION SQUARE and 16th STREET,

NEW YORK.

We make solid silver only, and of but one grade—that of Sterling, $\frac{925}{1,000}$ fine; therefore purchasers secure an entire freedom from false impressions, and the question "Is it silver or is it plated?" is never raised concerning a gift bearing the above trade-mark. We have produced the largest variety of special *Souvenir Spoons* for the trade, made by any silversmith.

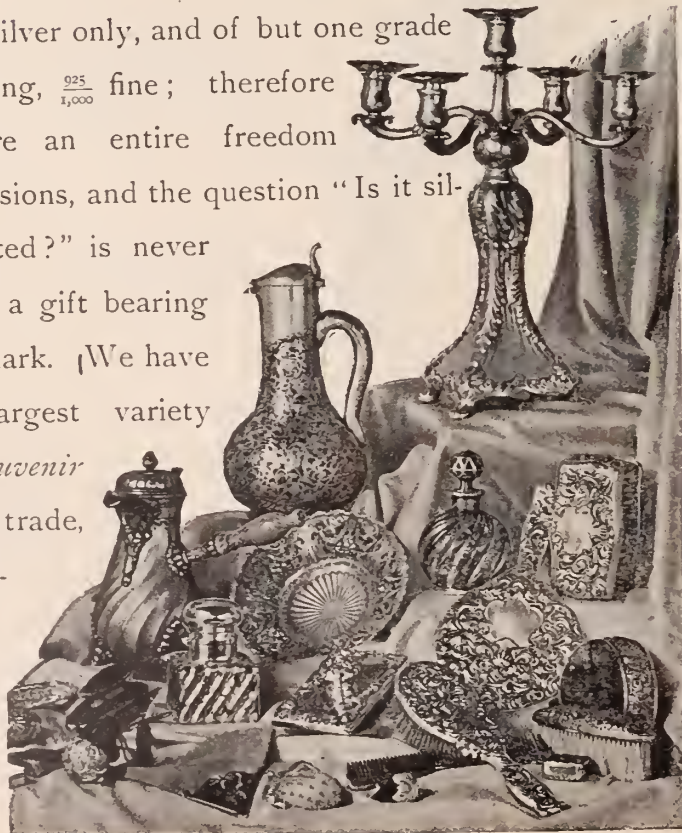

is oxidized while the bowl and the back of the spoon are bright finished. This handsome article is made in tea and orange sizes.

THE GEORGE WASHINGTON AND MARTHA WASHINGTON.

As previously stated, M. W. Galt, of M. W. Galt, Bro. & Co., Washington, D. C., while traveling in Europe about two years ago, collected numerous odd spoons. Upon his return home he conceived the idea of getting out a ladle that would be an exact fac-simile of the old Washington ladle preserved in the National Museum. To carry out the conception of a souvenir ladle he had stamped in the bowl of the article a medallion of George Washington. The firm later proceeded to produce spoons with a medallion of George or Martha Washington on the top of the handle or in the bowl; sometimes a medallion of one was in the bowl, while a medallion of the other was on the handle. The spoon is plain outside this simple decoration. The die work of the medallion is very



of George or Martha Washington on the top of the handle or in the bowl; sometimes a medallion of one was in the bowl, while a medallion of the other was on the handle. The spoon is plain outside this simple decoration. The die work of the medallion is very



THE VIRGINIA. THE NEWBURGH.

fine, the likenesses being exact. There has been a very large demand for this spoon; ten thousand of them have been sold yearly. It is made in various handsome styles.

THE MT. VERNON.

Of the same general outline and decoration as the White House spoon, is the Mt. Vernon, patented and sold by the same house, Harris & Shafer, Washington, D. C. Along the handle of this spoon are the words Mt. Vernon, in the same style of lettering as in the other spoon. Instead of the White House at the head of the handle, the building in which the immortal *Pater*



Patria lived and died is seen in perspective. The scene is very realistic, the large tree in front of the structure, the roadway, the surrounding hills all being accurately reproduced. The article is made in tea and orange sizes.



THE WASHINGTON NATIONAL.



THE NIAGARA.

MOORE AND LEDING'S MT. VERNON.

The design of the Mt. Vernon spoon, patented by Moore & Leding, Washington,

D. C., is the peer of any spoon produced, for beauty and appropriateness. The conception of the design embraces at the top of spoon the coat of arms of the Washington family, consisting of a swan passant on a shield bearing three stars and two stripes; below this coat of arms are the medallions of George and Martha Washington, showing full bust. These medallions are enclosed in pretty Louis XV. frames; below are the dates 1770-1789, indicating the time that Washington lived at Mt. Vernon. The stem of the spoon bears the name Mount Vernon in handsome letters. At the end of the stem is a wreath of laurel enclosing a star. A furling national flag caps into the bowl and partly over the home within the bowl, a very fitting surrounding. The tomb is purposely omitted, as the designer deemed its employment too sad and in poor taste. The likenesses, as will be seen by examining the illustration, are perfect, and the representation of the home is realistic. This beautiful article is made for tea and coffee.

NATIONAL SPOONS.

In the introduction to this series, it may have been well to specify a fifth *motif* in the designs of souvenir spoons, namely, national. Spoons of this class do not, of course, refer to any one city; they are intended for those true lovers of America, who accept everything tangible to keep their patriotism, the foremost sentiment in their hearts. They are also intended for foreign

visitors, who will take them away as mementos of their visit to America.

Among the first spoons of this class produced are the Washington, Lincoln and Grant, made in coffee, tea and orange sizes respectively. The characteristics of the designs of all are essentially the same. An accurate likeness of the national character is stamped toward the top of the handle. Under the bust of Washington is a sword and belt, denoting his willingness to fight for his country; under that of Lincoln, are two broken shackles, denoting the emancipation of the slaves, and under that of Grant, a sword and spray of leaves crossed, denoting greatness in war and peace. In the centre of the handle, depicted on a double furling ribbon, are respectively, Father of His Country, Savior of His Country and Defender of His Country. The designs it will thus be seen, are simple, though particularly significant of American patriotism. The Sterling Silver Souvenir Co., Boston, Mass., are the manufacturers of these articles.

THE WASHINGTON HEADQUARTERS.

During the summer months a regular line of excursion steamers ply between New York and Newburgh, N. Y., situated on the west bank of the Hudson, and the season sees hundreds of thousands of pleasure and curiosity seekers deposited at a town whose principal, perhaps only object of interest, is the old building in which General Washington made his headquarters during a considerable period of the Revolution. The old, oddly shaped

THE PAIRPOINT MFG. COMPANY, NEW BEDFORD, MASS.

Fine Gold and Silver Plated Ware.

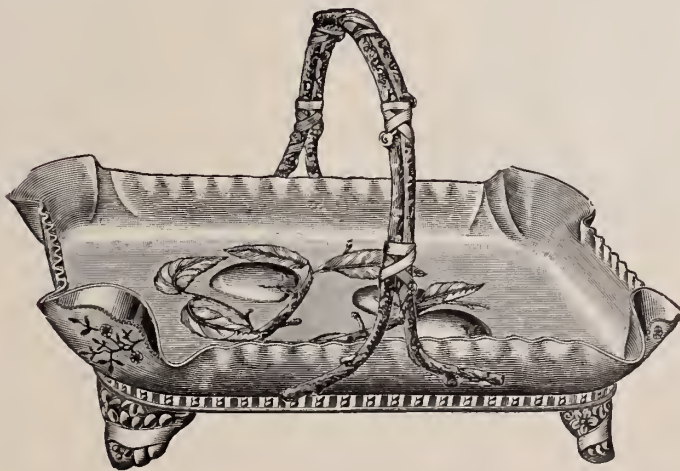

No. 1249. CAKE BASKET.



No. 2954. FLASK.

CATALOGUES AND PHOTOS TO THE TRADE ON APPLICATION.

NEW YORK.

CHICAGO.

SAN FRANCISCO.

building, which was erected in 1750, is under the care of the State of New York, and is well preserved. It is full of Revolutionary relics and from its site is afforded a clear view of the Hudson river to West Point, the seat of the United States Military Academy.

The spoon which depicts this historical building, though simple in design, is one of the handsomest on the market. This is owing to the unusual excellence of the die, which reproduces the minutest details, giving the scene a most surprising reality. The finest of engravings could not produce more detail. The surrounding trees stand out in relief, and seem separate from one another, though the appearance of the grove is preserved. The landscape is arranged lengthwise along the top of the handle, and the oxidizing of that portion of the spoon enhances the general effect. The word, Newburgh, curved, in small letters just beneath the view, comprises the remainder of the design. The bowl and back of the spoon are bright finished, and entirely free from ornamentation. W. H. Lyon, Newburgh, N. Y., has patented and controls the sale of this article, which is made in tea, orange, and other sizes.

PIERCED WORK IN SPOONS.

Perhaps as unique spoon as has come under the writer's notice is the Philadelphia, made and controlled by Myrick, Roller & Holbrook, of that city. The word Philadelphia, as seen in the illustration affords a beautiful example of pierced work, which,

as is evidenced by the spoon under consideration, is particularly felicitous in its application to souvenir spoons. The word appears to be formed of one continuous ribbon. The letters slant backward instead of forward, which arrangement seems to lend additional beauty. The manufacturers of this original and attractive spoon, on order will execute in the same style the name of any city in the handle of a spoon.

THE VIRGINIA SPOON.

The natives of the State that gave birth to such men as George Washington, Thomas Jefferson, James Madison, James Monroe, Patrick Henry, Edmund Randolph, John Marshall and others whose illustrious names adorn the pages of American history, have ever been imbued with perhaps a stronger love of country, than those of other States, and that part of the United States known as Virginia, or the Old Dominion, or the Mother of States, or the Mother of Presidents, has played a conspicuous part in the history of the country.

Among the celebrated men upon whom all Virginians look with loving pride, none occupy perhaps a higher place than General Robert E. Lee, whom many thinking and unprejudiced men consider to have been the greatest general the country has produced. General Lee was born in Virginia. He graduated at West Point and served in the Mexican war. In 1865 he was elected president of the Washington College, Rich-

mond, which after his death, Oct., 1870, was renamed the Washington and Lee University. In such high esteem is this figure in history held by the people of his native State, that to-day one of the principal features of the city of Richmond is the fine bronze statue of the general astride his charger, upon a very high and artistically designed pedestal. A miniature of this statue and pedestal forms the head of the handle of a souvenir spoon which the Gorham Mfg. Co., have produced to represent Virginia.

The details are perfectly reproduced. Below the pedestal, at the top of the main handle which is of architectural design, is a wreath of leaves. The bowl represents the coat of arms of the State, in die work. Above the figure of the victorious warrior is the motto of the State, *Sic Semper Tyrannis*; beneath, is the word Virginia. The workmanship of this spoon is of the same artistic and massive character as that of the New York spoons, described in the first part of this series. The spoon is a fine piece of work as a souvenir, and the demand for it is heavy.

THE HIAWATHA.

The figure of Hiawatha stands out in relief on the handle of the spoon in his might as Longfellow pictures him:

Out of childhood into manhood
Now had grown my Hiawatha,
Skilled in all the crafts of hunters,
Learned in all the lore of old men,
In all youthful sports and pastimes,
In all manly arts and labors.

The R. Wallace & Sons Mfg. Co.,



No. 230 CUP. IN STERLING SILVER, TWO-THIRDS SIZE.

MANUFACTURERS OF

Sterling Silver, Plated Ware & Fine Cutlery

FACTORIES, WALLINGFORD, CONN.

{ New York Store: 3 Park Place.
{ Chicago Store: 104 State Street.

Swift of foot was Hiawatha ;
He could shoot an arrow from him,
And run forward with such fleetness,
That the arrow fell behind him !
Strong of arm was Hiawatha ;
He could shoot ten arrows upward
Shoot them with such strength and swiftness,
That the tenth had left the bow-string
Ere the first to earth had fallen !

These details of manly strength, as seen in the engraving, are faithfully depicted. The representation of the costume of the son of Wenonah and Mudjekeewis accords in all particulars to the details of the bard's description. The Indian stands, apparently in a field of corn, with the tomahawk in one hand while his other hand is at his back. He appears to be gazing at the setting sun, the rays of which are seen behind him. The corn leaves and ears form the balance of the handle, which terminates in a pipe of peace and a quiver of arrows, upon which is artistically stamped the name, Hiawatha. The execution of these details is perfect. The front of the handle is oxidized, while the bowl and back of the spoon are bright finished.

Among the handsomest and most perfectly executed spoons produced are those referred to in the illustrations as a group of romantic subjects, the Hiawatha, Priscilla, Miles Standish, and Rip Van Winkle, made by W. B. Durgin, Concord, N. H.



HIAWATHA.

THE PRISCILLA.

"Then, as he opened the door, he beheld the form of the maiden
Seated beside her wheel, and the carded wool like a snow-drift,
Piled at her knee, her left hand feeding the ravenous spindle,
While with her right she sped, or reversed the wheel in its motion."

Thus John Alden saw Priscilla when he opened the door of her home, in the solitude of the forest, "making the humble home and modest apparel of homespun, beautiful with her beauty, and rich with the wealth of her being!" The picture as depicted in the poem, has been made familiar to the eyes of all, by the prints and engravings that form a portion of the decorations of thousands of homes. In the beautiful spoon that has been produced with this romantic subject or the main design, the Puritan maiden is seen entering the house of prayer, upon the door of which is the legend "Lord have

mercy on us." She stands in her simple habit, the personification of innocent beauty, purity and faith. The remainder of the handle is formed of twigs and reeds, twined about with a furling ribbon bearing the name, Priscilla. The outline of the spoon is extremely graceful, and is exteriorly ornamented by twining vines. The spoon is oxidized and bright finished as in the preceding case.

THE RIP VAN WINKLE.

A Rip Van Winkle spoon has already been described in this series. The one now under consideration shows Rip returning homeward



RIP VAN WINKLE.



MILES STANDISH.



PRISCILLA.

These romantic spoons are manufactured in tea and orange shapes, and the designs are all copyrighted.

THE NIAGARA.

The cataract of Niagara in the Niagara River is admitted to be the grandest in the world. The water from the broad basin of four of the Great Lakes here falls over a precipice 164 feet high, producing a scene of wonderful sublimity. No traveler thinks he has really seen the country if he has not visited Niagara; and thus the stream of sightseers who enjoy the beauty of the scene, is never-ending. It is natural that a handsome spoon should be produced as a Niagara souvenir, and this has been done by W. H. Glenny Sons

after his twenty years' sleep. His clothes are tattered and seem to be falling off his body. The long white beard falls over his chest, and his left hand presses his forehead in a gesture of amazement at his surroundings. The figure forms the upper part of the handle, the remaining portion depicting the long Dutch pipe which Rip loved to smoke in his youthful days, two tankards which he loved to toss, and the bowling balls which he would roll for hours. The same excellence of workmanship characterizes this spoon, as in the two preceding.

THE MILES STANDISH.

In the upper part of the exquisite handle of the third spoon, stands Miles Standish, "Short of stature he was, but strongly built and athletic,
Broad in the shoulders, deep-chested, with muscles and sinews of iron."

The Puritan Captain stands, as Longfellow pictures him, "clad in doublet and hose, and

boots of Cordovan leather." The sword of Damascus, curved at the point, hangs at his side. He wears the broad-brimmed hat and the belted coat, and looks into the distance with a martial air. In the background are leafless tree trunks. The remainder of the handle is formed of the Captain's "glittering weapons of warfare," his fowling-piece, musket and matchlock and bunches of leaves, seemingly held together by a twining ribbon of carded wool, bearing the name of Standish. The workmanship of this article appears to reach the highest point of possible perfection. The oxidized and bright finished effects are the same as in the preceding cases.

& Co., Buffalo, N. Y., who have applied for a patent on the design. The front of the spoon shows in relief the Prospect Point, the American and Horse Shoe Falls, with Goat Island between, and the rapids flowing down the stem, which bears in light relief, the name, Niagara; the back of the spoon is in W. B. Durgin's beautiful Louis XV. pattern. This spoon the front handle of which is oxidized while the remainder is bright finished is made in tea, coffee, orange and sugar sizes and shapes.

(To be continued.)

The Mt. Washington Glass Co., New Bedford, Mass., enjoy a national reputation for their justly popular, bright, new and attractive goods in richly decorated and fancy cut glass. An advantage afforded no other glass manufacturer is in the fact that their premises adjoin those of the well-known Pairpoint Mfg. Co.

"THE PLYMOUTH ROCK SPOON."

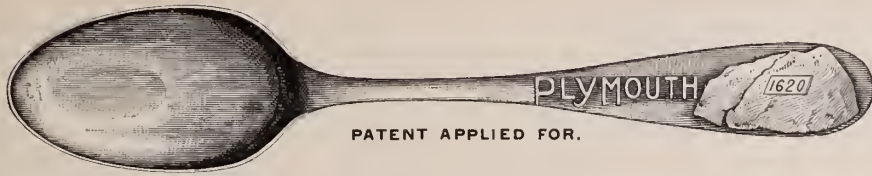

PATENT APPLIED FOR.

No collection of Souvenir Spoons complete without one from Old Pilgrim Plymouth.

THE SPOON has on the handle in raised figure, an exact fac-simile of the world-famous Rock on which our fore-fathers landed in 1620.

MADE IN

Orange, Sugar, Tea and Coffee Sizes,
IN STERLING SILVER ONLY.

SOLD ONLY BY

GOODING BROS.,

PLYMOUTH, MASS

Write for Prices.

NEW SHAPE. NEW CUT. WATER BOTTLE.

Can be seen at the

CUT-GLASS SHOWROOM OF

T. B. CLARK & Co.,

53 PARK PLACE,

NEW YORK.

ESTABLISHED 1865.
N. J. FELIX,
MANUFACTURER OF
GOLD AND SILVER WATCH CASES,
ROOMS 6, 7 AND 8,
71 Nassau Street, N. Y. City.
REPAIRING CASES (no matter how badly
damaged) A SPECIALTY.

A. PINOVER & Co.,

IMPORTERS OF

DIAMONDS



AND

Manufacturing Jewelers,

25-29 ANN STREET,

Cor. Nassau Street, NEW YORK.

Novelties in Diamond Mountings.

DAY & CLARK,

MAKERS OF

FINE JEWELRY,

BEAD NECKS AND BEAD BRACELETS.

CURB AND LINK BRACELETS

STRICTLY 14 KT.

10 MAIDEN LANE, N. Y.

WILLIAM B. DURGIN,

Designer and Maker of Wares in STERLING SILVER,

CONCORD, NEW HAMPSHIRE,

Cautions Manufacturers against infringement of Orange Spoon Bowl, as shown in accompanying cut, as it is fully protected by Letters-Patent.



MANUFACTURER OF FINEST LINE OF ORANGE SPOONS ON THE MARKET.

BY SPECIAL ARRANGEMENT, CERTAIN PROPRIETORS OF SOUVENIR SPOONS ARE PERMITTED TO USE THIS BOWL.

MAKER OF PAUL REVERE, NEW HAMPSHIRE AND PRISCILLA SOUVENIR SPOONS

THE BOWDEN Seamless Plain Ring,

IS MADE ONLY BY
J. B. BOWDEN & CO.,

Makers of FINGER RINGS of
every Description,

COR. BROADWAY & JOHN STREET,
NEW YORK.

TOWLE MFG. CO.,

MANUFACTURERS OF



Sterling Silverware



NEWBURYPORT, MASS.: 214 MERRIMACK ST.

CHICAGO:

149 & 151 STATE ST.

SAN FRANCISCO:

220 SUTTER ST.

BIRTHDAY * RINGS!

IN order to meet the increasing demand for BIRTHDAY RINGS, we have originated and Patented an attractive novelty in the shape of an elegant tray, containing of assorted patterns, 48 Rings, four for each month, with appropriate stones and the sentiments thereof, printed upon the tray in gilt letters.

As the whole four dozen cost but a very moderate amount, while we make no charge for the tray, which is of velvet and satin, as handsome as can be made, and the Rings it contains are of our latest and most desirable styles, we think that every Retailer will find it for both his interest and convenience to order this tray from us.

M. B. BRYANT & CO.,

* * RING MAKERS, * *

10 MAIDEN LANE,

NEW YORK.

THE "BRYANT" INITIAL RING, easily interchangeable, still keeps the lead as the best made—SIMPLE, STRONG and HANDSOME—in trays of 6 or 12, with separate initials.

Sympathized With the Poorly Paid Clerk.

MEMPHIS, Tenn., April 1.—A couple of mornings ago, R. Bertchy, of 202 Main St., discovered that he had been victimized to the extent of \$60 by a bogus check.

The utterer of the check is a young man of pleasing appearance, well-dressed, and fluent of speech. He made three visits to the store before he played his game. On the first day, which was early last week, this young man, who gave his name as C. H. Wilson, called at the store, and said he wanted to look at some rings. He didn't want to buy just then, but wanted to select a nice article so that he would know the cost when he got his salary. He didn't make a selection that day, nor did he on the following afternoon. He was such an agreeable conversationalist that Mr. Bertchy found it a pleasure to show him his stock. Wilson was very frank. He told the store-keeper that he was not rich, that he clerked in the office of a lawyer named Beale for \$60 per month, and had a wife to support on that salary. He said he would call on the following day with his wife, who would help him make a selection of a ring. He kept this promise.

About 4 o'clock on last evening he came to the store with a woman whom he introduced as his wife. The pair were not long in selecting a ring priced at \$20. Wilson then produced a check, which he said represented his month's salary. Mr. Bertchy did not hesitate to accept it. He wanted Wilson to take a \$50 watch instead of the \$20 ring, but the young man, who had a family to provide for, said that he needed the change, so Mr. Bertchy gave him the ring and \$40. Wilson and the woman have not been seen since.

A Noted Crook as a Watchmaker.

GALVESTON, Tex., April 1.—Some weeks ago Chief of Police Lordan of this city spotted a man named John Curry, working as a watchmaker in Migels' pawn shop, corner of 24th and Market Sts. The Chief knew something of Curry's record, and that he had recently been working the West. In answer to an inquiry he sent out, he received the following from Eldorado, Kan.

"Yes, arrest and hold Curry and advise me when the arrest is made."

Upon receipt of this Curry was arrested on Saturday.

Curry makes no denial of his identity as being one of the slickest crooks in the country.

He is a man about 33 or 35 years of age, and was born in Memphis. He is about 5 feet 9 inches in height, weighs 140 or 145 pounds, sandy complexion and beard and wears a moustache and chin whiskers. He has a prominent nose and small hands. In the centre of his forehead, just over the nose, is a deep wrinkle or furrow and the scar of a gunshot wound.

Curry has not attempted any nefarious work while here, and told the chief he was trying to keep quiet and behave himself. The Chief knows more of Curry's record than he thinks it at present best to tell.

Burglars Drilled and Ripped the Safe.

JERSEY CITY, N. J., April 3.—One of those daring robberies that regularly occur in the retail jewelry trade, took place last Monday in this city, and has so far baffled the efforts of the police to detect the perpetrators of the crime. The store of A. Walter & Son, 58 Newark Ave., was entered during the night, and jewelry to the value of \$3,000 taken from the safe.

The store is in the business center of the city, and was brilliantly lighted, and the safe front was plainly visible from the street. At one side of the safe, however, is an apartment hidden by a screen, used for testing and fitting spectacles for customers. The burglars, for there must have been more than one, got in at a skylight of an addition in the rear, bored through a partition back of the eye testing apartment, and sheltered from observation by the screen, drilled a hole in the side of the big 6x4 safe to the trays which contained the goods. The drills made a straight line for the most valuable contents of the safe, and a hole was made by using an iron "ripper" which tore out the side of the receptacle and dug through the plaster filling to the diamonds.

The "ripper" was found on the roof of the extension. It is an iron bar, eighteen inches long, with one end bent and pointed. This tool is also known among the police as a sectional jimmy. A broken drill, a bottle of sweet oil, used in drilling, and a carpenter's brace were found in the rear room.

The police pronounce the job the work of experts. It is supposed that one of the robbers called at the store recently about the time of closing for the day, on the pretence of having a ring repaired. When the ring was placed in the safe the robber noticed where the diamond trays were. The job shows that the burglars had studied the premises, and every move was prearranged. The detectives believe that the operators were not in the store more than one hour.

A. Walter & Son are members of the Jewelers' Security Alliance, and two Pinkerton detectives were immediately detailed on the

case on receipt of the news at the New York office of that organization. There is absolutely no clue to the identity of the burglars.

About a year ago, C. G. Rochat's jewelry store at 73 Montgomery St. was robbed by burglars, who hired an adjoining store and cut through the side of the building and into the back of the safe. They took watches and chains, some of which Mr. Rochat recovered, but the robbers were never arrested. The police believe these robberies to be the work of the same gang.

Canadian Custom Authorities Seize a Store

VICTORIA, B. C., April 1.—A. A. Clayton was last week served with a writ, at the instance of Collector Miline, claiming in the neighborhood of \$15,000. The sum is understood to be the amount of the fine added to the undervaluation of goods, as estimated by the customs, on the importations of the firm for the past two or three years.

His "Diamond Palace" has been seized by the authorities. Mr. Clayton has been doing a large business and has always been considered an upright business man. The matter will be settled in the courts.

A Curious and Interesting Time Piece.

BROOKLYN, N. Y., April 2.—W. B. Simonson & Co., 227 Fulton St., are exhibiting a clock which is attracting considerable attention from antiquaries and lovers of the unique. It is over two hundred years old. The dial is curiously wrought in silver and gold bronze, and is engraved and filled in with enamel. The day of the month is shown, and the dial indicates the phrases of the moon. The most wonderful feature of the clock is its sweet chime of bells, which play a number of tunes. The music is produced by twenty-five hammers, striking upon fifteen silver bells.

Littleton, N. H., March 24, 1891.
I do not want to miss any number. I am much pleased with the new Circular.

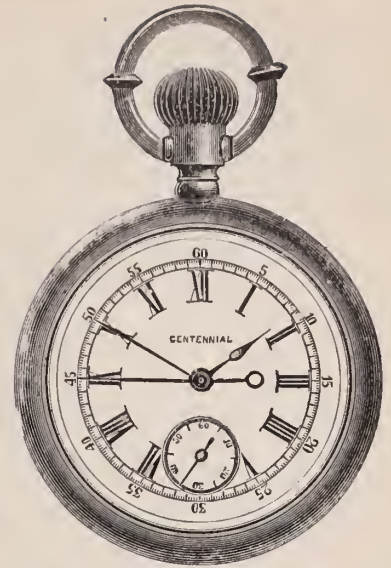

"THE CENTENNIAL"

LEADS THEM ALL.

Acknowledged by all dealers to be the best Chronograph in the Market. Made also as a Plain Timer.

Ask your jobber for them, or order of the Manufacturers,

CROSS & BEGUELIN,

21 Maiden Lane, N. Y.,

IMPORTERS OF

DIAMONDS, WATCH MATERIAL, OPERA GLASSES, Etc., Etc.

Jobbers of all grades of American Watches, Gold and Rolled Plate Jewelry.

SEND FOR PRICE LIST.

THE MOLL PITCHER SPOON.

(REGISTERED TRADE MARK.)

Moll Pitcher, of whom the poet Whittier wrote, was a noted Fortune Teller of Lynn, many years ago.

In accordance with a popular fad, we have originated the "Moll Pitcher" Souvenir Spoon.



We are confident that there will be a large and immediate call for these spoons; already we are receiving orders from retail dealers in different parts of the country.

Our purpose is to furnish these to only one jeweler in each city or town, except in the larger cities.

Send postal card for Circular Price List and Terms.

W. F. NEWHALL, Jeweler,

52 MARKET STREET.

LYNN, MASS.



Registered TRADE MARK.



A Lady's Ramble Among the Jewelers.

Asparagus cradles of silver wire are seasonable,

The modest arbutus in enameled silver is a seasonable pin.

Jeweled trimmings are the order of the day for all millinery purposes.

Crosses in gold, silver and gems are contesting favor with the popular lockets.

Large flat lockets of heart shape and enameled in blue, have a diamond in the centre.

A novelty in lockets is one the upper half of which is of gold, the lower half being silver.

There is no limit to the number of bracelets the present fashion permits with evening toilets.

For ladies use there are sun umbrellas fitted with watches, scent bottles and fans in their handles.

Locketts which are just now so fashionab'e as adjuncts to the chatelaine, neck and watch chains, are out in an infinite variety of patterns, and assume round, square and oblong shapes.

A double ring seen had one gold shank and one silver shank, each being set with a solitaire diamond.

It seems a trifle incongruous, but miniature copies of the souvenir spoons are masquerading as brooches.

There is some charming flower jewelry in which sweet peas and red clover appear to be favorite models.

Dainty necklaces are formed of tiny gold chains knotted at short intervals with a gem set in each knot.

For an elaborate coiffure there are small wreaths of silver flowers glistening with diamond dew-drops.

To meet the demand for one style of dressing the hair are plain bands of gold or silver, to be worn as fillets.

The revival of the leading modes of the Louis XV. period ensures the popularity of jewelry, for some time to come.

Shell-shaped bonbon dishes in silver of Louis XV. time, divide favor with the square Queen Anne styles with pierced borders.

An attractive heart-shaped brooch of pearls is bordered with a single row of turquoises and has a fine diamond glittering in its centre.

An attractive novelty provided for the 5 o'clock tea table, is a little diamond-shaped tray or dish for holding the useful lemon. It is surmounted by an upright basket handle with rests, on which reposes a saw-edged knife for cutting the fruit.

Gorgeous is the only adjective that will apply to women's attire at the present time, and jewelry is a prominent feature in this splendor

Flower pins, enameled in nature's colors, simulate a cluster of small blooms with the long, flexible stems twisted about one another in a graceful manner.

Innumerable little stick-pins headed with Maltese crosses and other church symbols are among the souvenirs of Easter likely to find favor during the present season.

At the present time fashion gives wide latitude for the exercise of individual taste and, as a consequence, jewelry is worn with more freedom by both sexes than before in years.

The latest heart jewelry is decidedly pointed, with one side swerved in irregular fashion. Where there is a union of two hearts, the effect, while peculiar, is graceful.

Pearls, always in fashion, are just now exceedingly popular. The demand for fine specimens, also for rare colored ones, is great.

Birthday rings are beginning to be the rage among young misses all over the country. There is a pleasing sentiment about the idea that tickles the feminine fancy, and puts the manufacturer on his mettle. These rings are now produced in a profusion of beautiful styles, and are attractively displayed in large gilt-lettered trays, in the jewelers' windows.

ELSIE BEE.

TO THE WATCH-RE-PAIR-HER.

When any Watch Tool Dealer tells you that ANY lathe is BETTER than the WEBSTER-WHITCOMB, ask for references from HIM and from US.

We have sold 6,402 lathes, and can give you references in all parts of the world.

If he says it is CHEAPER, remember the higher priced tool *may be* the cheaper—99 times out of 100 it is the cheapest AVOID IMITATIONS. We never knew an imitator to improve on the original.

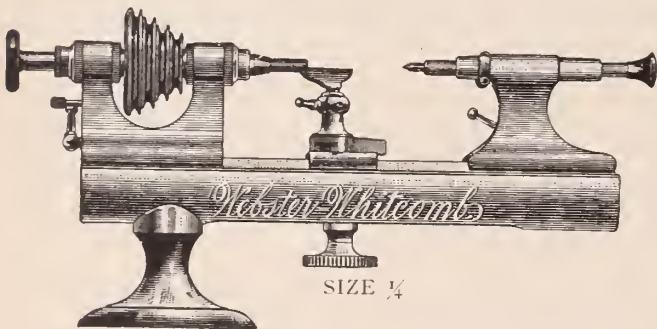

Consider this problem:—

Webster-Whitcomb Lathe.....	\$40.00
Whitcomb Lathe.....	30.00

Difference, - \$10.00

20 per cent. interest on difference is	\$2.00	per year.
12 Months in a year is	.166	" month.
30 Days in a month is	.0055	" day.
24 Hours in a day is	.0002	" hour.

This is all it costs for you to STAND UP and say
"I HAVE THE BEST."

Apply this calculation to *imitations*.

With every lathe we send the following guarantee:—

"This certifies that the lathe marked 'American Watch Tool Co., No. —' was made by us from the best materials, on the most approved plan, and is a reliable lathe. For any defect in material or workmanship we hold ourselves responsible. Notify us promptly of any faults.

"Waltham, _____

This guarantee is also signed by the inspector who has the final inspection of the work. For several years past we have tied upon every lathe a tag of caution and instruction. All purchasers are requested to demand these documents with the lathes they buy. Our address is unchanged.

AMERICAN WATCH TOOL CO.,

STONY BATTER WORKS,

In the birth-place of the American Watch Industry, which is WALTHAM, MASS



FLORAL JEWELRY PROMINENT—BRACELETS IN GOOD DEMAND—NOVELTIES IN ASH TRAYS.

PARIS, France, March 28. — Pessimists tell us with glee that, owing to a severe and protracted winter, the coming spring will bring us no flowers. This may account for the predominance in our jewelry shops of floral arrangements. I noticed several dew-sprinkled bunches of violets for corsage, consisting of gathered amethysts, with here and there a tiny brilliant, partly wrapped in green velvet leaves, with fine gold stalks held together by a bow-knot of diamonds; sweet briars, anemones, and heartseases delicately shaded in enameled gold; daisies in frosted silver with granulated gold in the center; orange-blossoms with pearls of an elongated shape, and leaves of gathered emeralds; snowberry sprigs arranged so as to be worn either on the hair or on the corsage, splendidly reproduced with large round pearls, etc.

Bracelets of the most varied styles are seen in all displays. Some consist of a large medallion with an allegorical scene painted in enamel, and framed with chased gold, the band exhibiting a succession of good-sized diamonds, running between two corded courses; several represent a wreath of gold ivy or laurel leaves; a few are in close network, with floral ornaments made of vari-colored stones, showing on the light background. Many, in pale yellow gold, reproduce pretty pastoral scenes, *genre Watteau*, in repoussé, chasing, etc. There is no decided fashion in that line, and as long as a bracelet is of a graceful pattern, whatever may be the substances employed to obtain the desired effect, it is sure to find a purchaser. The most different metals, platina, silver, gold, and even steel, are sometimes used in one article. Stones of all kinds, diamonds, rubies, sapphires, emeralds, amethysts, topaz, opals, beryls, peridots, etc., are all admitted in the decoration of bracelets, on condition that the stones chosen to adorn them be harmoniously arranged together.

Among fancy articles for Easter, I notice a scent-bottle, in the shape of an egg, in lapis-lazuli covered with chased interlacings of pierced gold. A chicken's head in gold appears out of the stopper, holding a tiny pearl in its beak.

A well-known shop, in the Rue de la Paix, exhibits several pretty ash-trays in pale yellow gold, with an oxidized silver border in open work. Graceful drinking and smoking scenes are chased on the center of these trays, which are of different shapes—square, round, oval and triangular. Besides, the outlines of the silver margins are often so fancifully carved that they greatly increase the originality of the designs.

ESTABLISHED 50 YEARS.
 RANDEL, BAREMORE & BILLINGS,
 IMPORTERS OF
DIAMONDS,
 AND OTHER PRECIOUS STONES.
 FINE PEARLS A SPECIALTY.

MANUFACTURERS OF
DIAMOND JEWELRY,
 IN THE LATEST DESIGNS.

Diamonds Recut in Modern Styles or Repaired on Premises.

58 Nassau Street,
 29 Maiden Lane,
 NEW YORK.

1 Tulp Straat,
 AMSTERDAM.

1 St. Andrews St.,
 Holborn Circus.
 LONDON, E. C.

LARTER, ELCOX & CO.

MANUFACTURERS OF

THE SPRING BACK STUD.

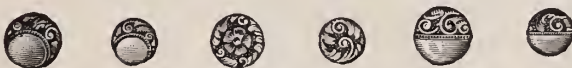
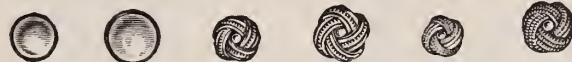

Send for Selection Package of Studs.

SNAKE RINGS.

GENTLEMEN'S
 WHITE · ONYX · JEWELRY.

LADIES' RINGS.

Gentlemen's Rings.

FACTORY, NEWARK, N. J. + + OFFICE. 41 & 43 MAIDEN LANE, N. Y.

A. J. GROENMAN & CO.,
 DIAMOND CUTTERS,
 80 NASSAU ST., N. Y.
 WE MAKE A SPECIALTY OF SEL-
 !ING FINE, SMALL MELEES.

BOOK * MARKS
 IN
 STERLING SILVER,
 FRANK H. LA PIERRE,
 No. 18 East 14th St., New York.

FACTORY,
 ST. IMIER, SUISSE.

HIPP DIDISHEIM,

83 NASSAU STREET,
 NEW YORK.

IMPORTER OF WATCHES,

SPECIALTIES:

The "*Nassau*," the best imported movement in the market, fitting all American cases.
 The "*Mignon*," the best Chatelaine Watch for the money.
 The "*Gem*," a high grade Chatelaine Watch with second hand, gold crown jewels in extra settings, etc.

If your jobber don't keep these goods, send to us and we will send you the address of one who does.



SEE THE NEW CUTTINGS
FOR 1891,
CRESCENT
+ + AND + +
OLYMPIC

The best American Cut Glass is that
manufactured by

THE PHENIX GLASS COMPANY,

OF PITTSBURGH, PA.

Unequaled in its BRILLIANCY, DEEP CUTTING and DESIGN.

729 Broadway, Cor. Waverly Place, N. Y.

43 SIXTH AVENUE, PITTSBURGH, PA

WATCH DIALS.

Any kind watch dial duplicated within ten days. Factories supplied with dials for their entire product or with special designs for their high grade movements. Special rates for large quantities. Emblems, photographs, landscapes and ornamental work of every description on plain, enamel or under glaze.

WALTHAM DIAL CO.,
WALTHAM, MASS.

A. RICKERT. C.A. STIEHLE.

RICKERT & STIEHLE,

MANUFACTURERS OF

GOLD CHAINS,

SWIVELS AND SPRING RINGS.

Chain Repairing a Specialty.
13 & 15 Franklin Street, NEWARK, N. J.

WE DESIRE to call your attention to our large and varied assortment of

Complicated, High Grade Gentlemen's and Ladies'



In Gold Cases, both Plain and Enameled, in Choice Designs.

THE LARGEST STOCK EVER SHOWN IN THIS COUNTRY.

NON-MAGNETIC WATCH CO.

OF AMERICA.

CHAS. MCCULLOH, RECEIVER

177 Broadway. - - NEW YORK.

AIKIN, LAMBERT & Co.,

23 Maiden Lane,

NEW YORK,

Manufacturers and Exporters of

Fine Gold Pens, Pencils,

TOOTHPICKS, HOLDERS,

And Novelties in Silver, Pearl, &c.



THE BEST FOUNTAIN PENS.

New Assortments in SHOW CASES and FANCY TRAYS for JEWELERS. Price Lists and Catalogues for intending Purchasers.



Also American and Swiss Watches.

DIAMONDS, Loose and Mounted,

Gold and Silver Thimbles,

CHAINS and JEWELRY in New and Staple Patterns.

ESTABLISHED 1837.

TAYLOR & BROTHER,

OLD HOUSE READ, TAYLOR & CO.

IMPORTERS OF

DIAMONDS and PRECIOUS STONES,

CLOCKS AND BRONZES,

860 Broadway, cor. 17th Street, N. Y.

Branch Office for Clocks and Bronzes,

1 1/2 MAIDEN LANE N. Y.

E. R. STOCKWELL,

19 John Street, New York.

All descriptions of

BADGES, * MEDALS, * PINS,

For Colleges, Schools and all Societies,

IN SILVER AND GOLD.

Jobbing and Repairing for the Trade.

BOOKS FOR JEWELERS.

W. B. DICKIE,

67 William Street, New York,

PUBLISHER OF

Improved Watch Stock Book

— AND —

Improved Watch Repair Book.

SEND FOR DESCRIPTIVE CIRCULAR.

News Gleanings.

J. H. Rhodes, Marion, O., is out of business.

G. F. Stedman has moved from Cuyahoga Falls, O.

J. M. Crundwell, Brownwood, Tex., has sold out.

A Gehring, Carlisle, Pa., is moving to a new store.

G. Ryder, Marion, O., is selling out his stock at auction.

F. J. Alexander, White Lake, S. Dak., has gone out of business.

R. Jurgensen, Schoharie, N. Y., has sold out to Manley Patchtle.

A. H. Cambell & Sons, Sweetwater, Tex., have gone out of business.

A. P. Breihoff, Berwick, Pa., has confessed judgment for \$1,000.

E. R. Vining has moved from Callaway, Neb., to Waverly, same State.

The Rock Hill Watch and Optical Co., Rock Hill, S. C., have dissolved.

R. G. Abbott, has moved from Birmingham, Conn., to North Adams, Mass.

Kent Bros., 119 Franklin St., Buffalo, N. Y., are advertising a jewelry store for sale.

Richard Mockford, of Trumansburgh, N. Y., has moved his store into the Collins block.

F. A. Smith and G. A. Francis, Wilmington, Del., have moved from 603 King St. to 221 W. 2d St.

N. C. Nelson, Concord, N. H., recently presented to the police force of that town a handsome eight day clock.

R. B. Freeman, recently of Trenton, N. J., is now located at Basic City, Va., where he has opened a jewelry business.

C. S. Allen, who recently bought out the business of J. H. Isham, 301 Main St., Buffalo, N. Y., will occupy the store on May 1.

It is said that Christian Bauman, who recently arrived from Geneva, Switzerland, intends to settle at Elgin, Ill., and start a watch manufactory.

A man named Samuel Freedman was arrested last week at Buffalo, N. Y., on a charge of grand larceny, in stealing a quantity of jewelry from a Rochester house.

Allen Fellencer, for the past ten years with J. K. Rauch, Bethlehem, Pa., has resigned his position with the intention of opening an establishment of his own in that town.

Des Moines, Ia., it is said, will soon have a horological school, to bear the name of Des Moines National School of Technology. Watchmaking and engraving will be the principal branches of instruction.

The auction sales at the store of G. A. Collins, conducted by J. H. French, the well-known jewelers' auctioneer, have been very successful. Mr. Collins will continue the business, which has been established for twelve years, with a much larger and finer stock and on a more solid financial basis than ever before.

USE THE  **AMERICAN MAINSPRINGS**
FOR ALL KINDS OF AMERICAN WATCHES.
[FACSIMILE OF WRAPPER.]

1 DOZ. MAINSPRINGS
18 S. E. O. S. 
Extra Quality.
TRADE  MARK.

THE BEST IN THE MARKET.

L. H. KELLER & CO.,
Dealers in Fine Watch Materials and Tools.
AGENTS FOR THE PATEK, PHILIPPE & CO. WATCHES.
64 NASSAU STREET, NEW YORK.



JOHN A. RILEY & SLOAN Co.,

860 Broadway, New York.

MAKERS OF

HAIR PINS, HAT PINS,
TIARAS, BROOCHES,
SCARF PINS, NECKLACES, ETC.

Rosaries & Crucifixes, Chatelaines.

Our line includes both 14k. Gold and Sterling Silver.



407



348



408



405



409



397-91



404



244

EXAMPLES OF CLASS PINS (PLATE 26, COPYRIGHT 1891), DESIGNED AND MADE BY HENRY C. HASKELL, 11 JOHN ST., NEW YORK. PLATES SENT TO DEALERS UPON REQUEST.

"THE BEST."
THE
Dueber Watch Case.

GENERAL OFFICE,

THE DUEBER WATCH CASE MFG. CO.

CANTON, OHIO, March 1, 1891.

TO THE TRADE:

This Company has been reorganized and all heretofore existing difficulties adjusted. We are now ready for business and respectfully solicit your trade, as all obstacles which heretofore retarded our progress have been successfully removed.

As we desire to increase our Jobbers' list, we solicit correspondence from responsible houses in cities where we now have no Jobbing representatives.

In order to better serve all our customers with promptness and dispatch, we shall discontinue our New York, Boston and Chicago Offices and ship all goods from our Canton (Ohio) Office.

Our Offices in the above cities are for rent and fixtures for sale.

Address all communications to

THE DUEBER WATCH CASE MFG. CO.,
 CANTON, OHIO.

SOMETHING • NEW.

ALUMINUM THIMBLES.

Light, Durable and will not tarnish.

In appearance similar to Silver, and at half the cost.



If you want something NEW, HANDSOME and CHEAP, send, enclosing business card, for samples and prices.

KETCHAM & McDOUGALL,
 198 Broadway, New York.

W. J. Callison, Columbia, Ky., has sold out.

J. T. Jackman, Toledo, Ia., is out of business.

W. J. McMinimy, Harrodsburgh, Ky., died recently.

C. W. Richardson, Woodland, Cal., has sold out.

R. W. Canfield is out of business at Conway, Ark.

A. Ufford has moved from Herman, Minn., to Vancouver, B. C.

W. E. Huston, Rock Valley, Ia., has sold out to O. W. Masters.

W. C. Davis has moved from Cambridge City, Ind., to Elkhart, same State.

Warren, Spayth & Co., Toledo, Ia., have dissolved. Warren Spayth continues.

Charles Beardslee, Moss Point, Miss., by a recent fire in that village lost \$700 to \$800.

The New York Jewelry Mfg. Co. will in a few days open a store at Birmingham, Ala.

D. D. Wiggins, Farmer Village, N. Y., has transferred his business to C. S. Wiggins, and has moved to Elmira, same State.

C. Reinheimer, optician, 44 Fifth Ave., Brooklyn, N. Y., has given a chattel mortgage to C. Z. Tagliabue for \$1,114.

C. A. Brown has moved from Long Prairie, Minn., to Appleton, same State. He has been succeeded at the former place by F. L. Brown.

G. E. Sherwood, Waterloo, N. Y., has constructed an apparatus for demagnetizing watches, which is claimed to be working successfully.

D. D. Palmer, Waltham, Mass., has just completed a diamond draw-plate which will draw wire to three-thousandths of a centimetre.

F. L. Ripley, Tyrone, Pa., has closed out his business in that town, in order to assume the control of the jewelry business of his father, L. G. Ripley, Dansville, N. Y., who is an invalid.

Joseph Grousse has opened a jewelry store on Susquehanna St., a few doors below the Mauch Chunk House, Mauch Chunk, Pa. He was formerly located near the corner of Centre and First Sts., East Mauch Chunk, Pa.

The New York *World* has extended its jewelry business, and is now advertising repeating watches in gold cases "manufactured to be sold on the market at between \$200.00 and \$300.00" at prices "averaging about \$137.00."

D. C. Massey, 404 King St., Wilmington, Del., received last Monday morning an 18-karat gold ring worth \$11.50, which had been dropped through the letter box of his door. The ring had been worn, and as no name or address of any kind accompanied it, Mr. Massey is of the opinion that the ring is one of a number that had been stolen from him three years ago last February.

Jacob Kohl, Mendota, Ill., died recently.
 J. H. Caruss, a New York eye specialist, is in Florida.

J. Gumbinger, Jacksonville, Fla., is exhibiting 3,000 pearls.

J. J. Newhard, Lebanon, Pa., is critically ill with few hopes of recovery.

C. N. Molyneax, Picture Rocks, Pa., is having a fine new jewelry store erected.

F. B. Rice, manager of the Aurora Silver Plate factory, Aurora, Ill., has returned from his trip East.

The business of C. H. Hollis, La Grange, Ind., will on April 13 be sold out at Sheriff's sale.

Greenleaf & Crosby, Jacksonville, Fla., are making a fine window display of souvenir spoons.

The stock of jewelry of L. Wurth, Salt Lake City, Utah, was last week disposed of at public Sheriff's auction.

Salzman & Lyles, Danville, Va., have provided themselves with a chronometer which they will place in their show window.

A. Davison, Dekalb, Ill., has purchased an extensive business in Portage, Wis., and has moved with his family to that town.

The watch which was stolen from Dilger's store on Feb. 18 was returned last week by a colored woman. A. Newman is in jail awaiting developments.

Notwithstanding the prevalence of the grippe, the March output of the Elgin watch factory was over 1,900 movements a day.

The Kissingen Spring Company, Saratoga Springs, N. Y., have leased to Casperfield & Co., New York city, the store No. 371, now occupied by them as an office.

The *Daily Eagle*, Brooklyn, N. Y., last week gave a very complimentary notice of the Easter display in the windows of Wm. Wise & Son, 239 Fulton St., that city.

Wm. Egermann, Aurora, Ill., has just received some very fine souvenir spoons, with the word "Aurora" engraved on them. They are the first ever brought to this city.

J. R. May was arrested at Harrisburgh, Pa., last week, on a charge of false representation. He is a jewelry fakir who has been in the clutches of the law on more than one occasion.

The Elgin Clock Co. was incorporated at Elgin, Ill., on March 28, to manufacture and deal in clocks. The capital stock is \$100,000. The incorporators are Edgar Madden, W. F. Hoig and G. W. Warvelle.

Burglars on the morning of Sunday before last entered the store of Ellis Bros., Bedford, Ind., and stole twenty-five watches. Admittance was gained by prying a sash out of a window in the rear of the building.

Last week Daniel Brown, a painter who was engaged in decorating the store of De

Gontard & Reynolds, Scranton, Pa., was arrested, charged with stealing a watch. He was committed in default of \$300 bail to the county jail.

The store of C. L. Erath, 531 Twelfth St., Milwaukee, Wis., was broken into recently, but the robbers were scared by the noise and fled before taking anything. A heavy plate glass was cut and then broken in. The police are working on the case.

On the night of April 1, thieves raided Oaktown, Ind., and entered every store in the place except two. They were after money, for they took nothing but money and jewelry. At the drug and jewelry store of Peifer & Reed, they cracked the safe and secured money and jewelry to the value of \$500.

H. G. Goldschmidt, with Mrs. T Kircher, Davenport, Ia., has returned from Chicago after a course in the Chicago Ophthalmic College, and will hereafter superintend the optical department of the store. He graduated from the optical course and will be able to exhibit his diploma to his friends within a few days.

Foltz & Frank, Akron, O., will May 1 week dissolve partnership. Messrs. Foltz & Frank have been in business together since 1875 and it is only on account of Mr. Foltz's desire to be with his family, who are traveling because of Mrs. Foltz's ill-health, that the dissolution takes place. W. J. Frank will continue the business.

NATIONAL SOUVENIR SPOONS.

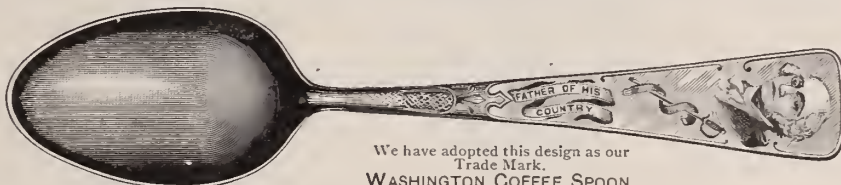

We have adopted this design as our Trade Mark
 WASHINGTON COFFEE SPOON.

WHY SHOULD YOU BUY THESE SPOONS?

- First.* Because they represent the three most noted men this country ever produced.
- Second.* Because the designs are patriotic in their nature, and everybody will want them for keepsakes.



We have adopted this design as our Trade Mark
 LINCOLN TEA SPOON.

Third. Because the craze for collecting Souvenir Spoons is contagious, and every lady in the land must have the disease. Our National spoons are the remedy.

Fourth. Because all foreigners visiting our country will buy these souvenirs of our noted men for their collection of keepsakes.



We have adopted this design as our Trade Mark.
 GRANT ORANGE SPOON.

Fifth. Because when your customers buy, they will buy the trio instead of buying only one, as they do of other designs.

P. O. DRAWER NO. 5324.

Very truly yours.

Sterling Silver Souvenir Co.

SEND FOR ILLUSTRATED CIRCULAR AND PRICE LIST

"THE SIR WM. JOHNSON SPOON."



One of the most Artistic and Historic Souvenir Spoons now on the market.

THE spoon has on handle the bust of Sir Wm. Johnson, and in bas-relief, the old Sir Wm. Johnson Hall and Forts; still further down a Ladies Glove and the word *rsville*, representing Gloversville, and the chief industry of the town.

MADE IN Tea, Coffee, Orange Spoons, in Sterling Silver only.

Send for price list.

For sale by

A. D. NORTON,
GLOVERSVILLE,
NEW YORK.

REMOVAL.

R. A. BREIDENBACH,
IMPORTER OF
DIAMONDS
PRECIOUS AND IMITATION STONES,
IS NOW LOCATED AT
51 & 53 MAIDEN LANE.
Largest line of Stones of every description.

"THE GRADY"

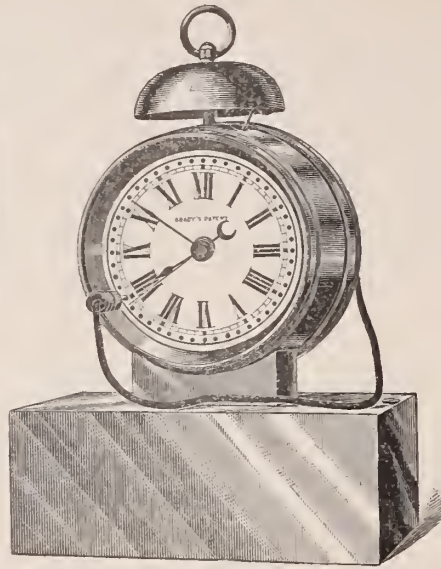

Electric Alarm Clock and Call Bell.

The attention of the Trade is directed to this new invention, which is the most complete, economical and trustworthy of its kind.

The Electric Bell, Battery and Movement are all inclosed in a finely finished Nickel-Plated Case, making it as compact and portable as the ordinary mechanical alarm clock.

OUR CLOCK RINGS UNTIL YOU GET UP AND STOP IT, and is therefore invaluable to all parties required to get up at a given time. It is also having a large sale among business men, who find it a perfect time keeper and an excellent call bell for desk purposes, as the bell rings by simply touching the contact pin to any part of the clock case.

We will send them by express to any part of the United States or Canada upon receipt of price.

DISCOUNT TO THE TRADE.

THIS IS THE ONLY ELECTRIC ALARM CLOCK EVER HANDLED BY THE LEADING JEWELRY AND CLOCK STORES OF NEW YORK AND BROOKLYN.

SEND FOR DESCRIPTIVE CIRCULARS AND PRICES.

T. H. GRADY & CO.,

Sole Manufacturers,

263 Fulton Street., - Brooklyn, N. Y.

S. C. JACKSON, 180 BROADWAY, NEW YORK,
MANUFACTURER OF

Fine * Cases * for * Jewelry, * Silverware, * Etc.,

ALSO SHOW CASE TRAYS AND FANCY HARD WOOD WORK.
Samples sent on application. Estimates furnished.



Fleur de Lis "VICTORIAS."

WE ARE SHOWING THE

Most Popular Line

IN THE MARKET.

H. F. BARROWS & Co.,

1½A Maiden Lane, N. Y.

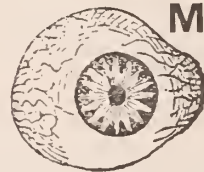

MUELLER'S ARTIFICIAL EYES
ARE THE BEST IN THE

M. ZINEMAN & BRO.,

130 So. Ninth Street, Philadelphia, Pa.,

Sole American Agents. Quantities Sent For Selection.



PLYMOUTH * ROCK,
OR LANDING OF THE PILGRIMS.

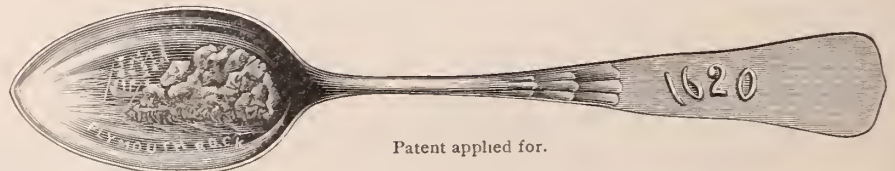

Patent applied for.

The above is the exact size of Homer's Plymouth Rock Souvenir Spoon, made only in Sterling Silver and for sale by

GEO. E. HOMER,

112 Tremont Street,

BOSTON, MASS.

The Illinois Watch factory at Springfield, Ill., last week came very near being afire. Some one had left a lighted torch in room A which became overturned, spilling the oil on the floor which soon ignited and cast a ruddy glare over the entire room. It was discovered just before the whistle blew for six o'clock and had it occurred a few minutes later the shop may now have been a mass of ruins.

G. W. Smith, a Kentucky jeweler, is said to be in trouble. Several of his friends in Harlan County pooled their cash and sent him to New York to buy "green goods." He returned shortly without cash or goods, saying that he had been swindled out of the money. The Kentuckians do not believe the story, and they have had Smith in jail for some time, awaiting trial for swindling them.

Wm. Glover, Jr., Hazleton, Pa., has just installed in his store a new York safe weighing 15,000 pounds. Its inside height is 60 inches, width 54 inches, and depth 20 inches; its outside height is 90 inches, width 68 inches, and depth 38 inches. It is fire and burglar proof, the inside lining being 1½ inch chrome steel, alternate, hard and soft metal. It has a combination in the outside and inside doors. The safe is fitted with 40 drawers, 60 tray slides, and extra spaces for boxes and books. Its cost was \$1,000.

William Dille, who was arrested recently for stealing goods from the Dueber watch case factory, last week waived examination and was bound over in the sum of \$500. The goods found in his room consisted of all manner of tools, screws, second hands, glasses and various parts of a watch. Some of the screws were very small and his method of securing them was quite novel. He would go to the bench of the person using them and while talking would wet his finger and carelessly put it on a pile of screws. A dozen would

adhere to his finger and a few visits would give him a good supply.

A Jewelry Traveler Robbed While Asleep.

CHARLOTTE, N. C., April 1.—W. J. Johnston, a traveling salesman, for Heeren Bros. & Co., Pittsburgh, Pa., was robbed of \$200 in cash, a fine gold watch worth \$275, and several articles of clothing, while stopping at the Buford Hotel early Sunday morning. His two trunks, containing \$30,000 worth of samples, were deposited at the office, else in all probability they would have been sacked. The local detective has the case in hand, but there are no clues.

The watch is a chronograph of the following description: 18-K hunting case; engine turned; about 60 dwts.; left spring broken; the movement is nickel; maker's name not recorded though there is a peculiar trademark; chronograph attachment under dial; key set regulator; gold name plate on movement plate, not engraved; Arabic dial; number of movement 15,640. There is a tooth broken out of a winding wheel.

Three Months' Patents—July-Sept., 1890.

WASHINGTON, D. C., April 1.—The alphabetical lists of the inventions for the quarter ending Sept. 30, 1890, just issued, give the following figures regarding the patents granted on devices connected with the jewelry, watch, optical and kindred trades; aluminum and processes, 3; clocks, etc., 6; clock cases, 2; clock attachments, 5; dials, 3; engraving machines, 4; engraving machine attachments, 2; eyeglasses, 5; eyeglass case, 1; eyeglass holders, 2; jewelry, 10; jewelers' tools, 3; jewelry processes, 5; opera glasses, 2; time detectors and indicators, 7; watches, 8; watch cases, 1; watch attachments, 3; watch case attachments, 10; watch appara-

tus and processes, 7; watch keys, 2; watch movement boxes and cases, 3; watchmakers, tools, 3; watch demagnetizer, 1.

Of designs, patents were granted on jewelry, 4; cane and umbrella handles, 12; toilet silverware, 6; flatware, 4.

Of trademarks, patents were granted on tools, 1; jewelry, 3; flatware; watches, 1; watch cases, 7; watch insulator, 1; silverware, 2.

A Pennsylvania Dealer Forced to the Wall.

MAUCH CHUNK, Pa., April 2.—Samuel Carpenter, one of the leading jewelers of this town, this morning made an assignment of all his property to L. F. Leibfried, of Bethlehem, this State, for the benefit of his creditors. The store is not closed and Mr. Carpenter will have charge of the business, which will be continued for a time by the assignee. The amount of the liabilities is not stated, but it is thought that the stock and accounts will liquidate the debts dollar for dollar. An appraisal of the stock will at once be made by J. C. Dolan and E. R. Enbody, who have been appointed for that purpose.

Mr. Carpenter came to this town about twenty-one years ago, and entered the employ of jeweler J. C. Dolan, with whom he continued for thirteen years. He then succeeded Mr. Dolan and has conducted the business up to the present time, doing a fair trade, though apparently not a paying business, for the past several years. In explanation of the present step the insolvent says that his capital when he started was very limited, but for the first several years this did not interfere. Of late years, however, he says it was a continuous struggle, wearing in mind and body, to make both ends meet. Since there were no prospects of an improvement in the near future, he concluded it would be most honor-

THE "MOUNT VERNON" SOUVENIR SPOON.

MEMENTO OF

THE HOME OF WASHINGTON.

HANDSOMEST SPOON YET PRODUCED IN THIS LINE.

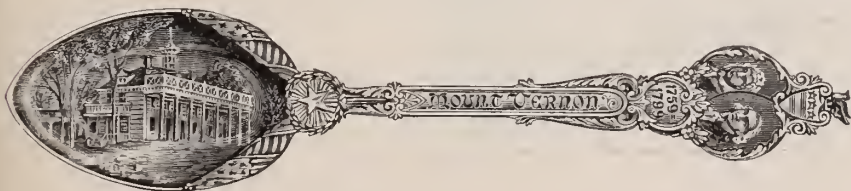

SURE to sell in all parts of the Country, because of its historic interest and artistic merits.

Orders will be taken for delivery about May 1st.

MOORE & LEDING, SILVERSMITHS,

PATENTEES OF THE CELEBRATED "WASHINGTON CITY" SPOON.

1109 Penna. Ave., Washington, D. C.

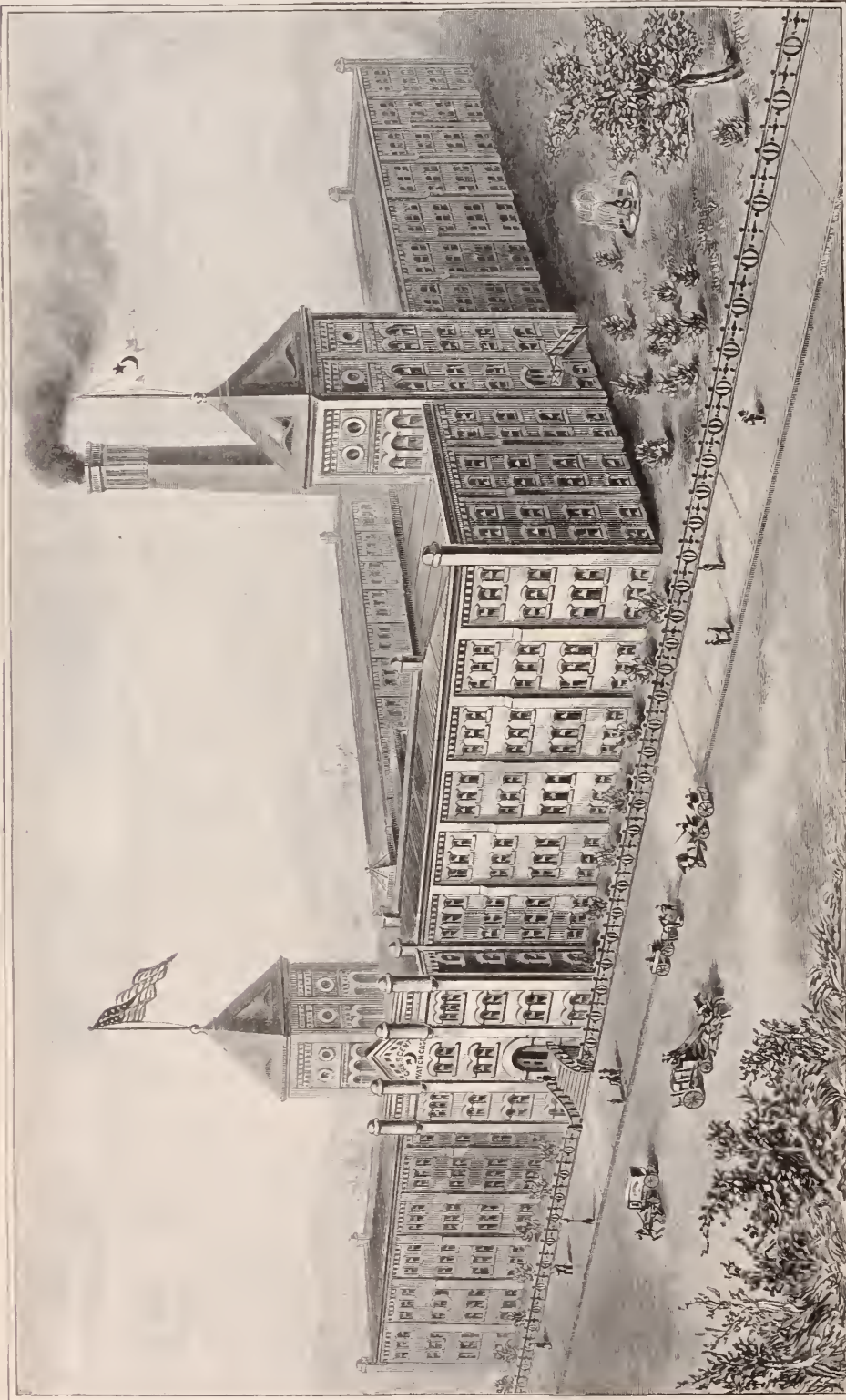

THE NEW FACTORY OF THE
CRESCENT WATCH CASE COMPANY,
NEWARK, N. J.

able to wind up, while yet in a position to pay as nearly as possible all his creditors.

The creditors are chiefly New York and Philadelphia wholesale houses. These were not pushing him, but the assignment was entirely voluntary on his part. Craig & Loose, of this town, are the attorneys for the assignee.

The Ghastly Finds Were Not of Swenson.

MONTREAL, P. Q., April 2.—The newspapers of this city for the last month have been more or less concerned about the missing jeweler, Swenson. The *Star* and the *Herald* each published column articles of conjecture as to the disappearance. The snow is now melting away, and the usual spring salvage comes to light.

A human hand was this week found in a by-street where a dog was gnawing it, and it was thought that a clue to Swenson had been found, but nothing came of it. Some children found a human leg in a large ash-heap, and it was noised all over the city that Swenson had ended his life among the ashes. However the limb was found to have belonged to a student. A dead man was a few days ago, found at a village a number of miles from this city; an inquest was held by the local coroner. A detective who knew Swenson perfectly, viewed the body, but the features were so decomposed that he could not be sure, though the body bore a striking resemblance to the missing man. The hair, etc., were those of Swenson. Friends went to see the body, but could not decide. One of the more daring forced the mouth open and found a set of natural teeth. Swenson's were poor and worn to the gums. So the mystery stands.

The New Hays Building.

On May 4 workman workmen will begin the demolition of the structure 21 and 23 Maiden Lane, New York, which is to be replaced by the new Hays Building. J. R. Thomas is the architect for the new building and to a CIRCULAR reporter last Thursday, he said that when finished the building would rank among the finest in the city. It will be eight stories high with a frontage of over fifty feet. The first two stories will be of heavy granite, and the rest buff brick with terra cotta trimmings. It will be thoroughly fire proof the floor being divided by arches of fire brick, and iron. All sides of the building will be lighted and in the centre will be a court lighted from a skylight above. The halls and corridors will be paved with marble and contain such ornamental iron work as is consistent with a first class office building. Two swift running passenger elevators, one of which is to be especially constructed for the conveyance of heavy safes are among the other features of the structure.

The Hays Building will be completed by February, 1892, and among the jewelers who will be located there are, Enos Richardson & Co., N. H. White, Eisenmann Bros., and the Courvoisier-Wilcox Mfg. Co.

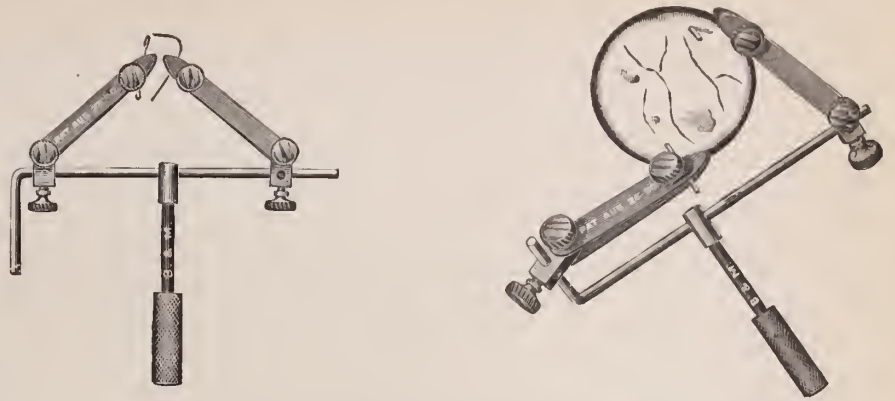

Magic Repair Clamp. Price \$1.25.

(Bowman & Musser, Sole Agents.)

The wonderful sale of this tool has surprised no one more than ourselves. We take its phenomenal sale as a high endorsement of its merit, in addition to the many voluntary testimonials which we have received.

For sale by jobbers in Tools and Materials, or will be sent by us, postage prepaid, on receipt of price.

Bowman & Musser,

Importers and Jobbers,

Watches, Chains, Spectacles, Tools and Materials,
Lancaster, Pa.

SOUVENIR * WATCH

*** * SPOON. * ***

(Patented.)

Particularly Adapted to the Watch Trade.

Name of any city or town can be etched in the bowl.

We have a large assortment of sterling silver souvenir spoons to which we are constantly adding new designs. Send for samples.

HENRY T. SPEAR & SON,

Wholesale Dealers in

American Watches and Silver Plated Ware,

370 WASHINGTON ST.,

BOSTON,

MASS.

JAMES P. SNOW.

ESTABLISHED 1834.

CHAS. E. WESTCOTT

SNOW & WESTCOTT,

SUCCESSORS TO G. & S. OWEN & CO.

MAKERS OF

FINE JEWELRY,

Lace Pins, Ear Rings, Scarf Pins, Sleeve Buttons, Sash Pins, Collar Buttons, Bracelets, Studs.

All Goods sold by us are exclusively of our own manufacture and are warranted 14 K. Fine, and stamped as such when possible.

No. 3 MAIDEN LANE, NEW YORK.

They Robbed to the Strains of Music.

LOS ANGELES, Cal., April 1.—It was discovered on Thursday morning, that the music and jewelry store of Bartlett Bros. had been entered during the previous night, and robbed of \$2,500 worth of goods, mostly from the jewelry department.

The store door had been closed but not locked, as a musical rehearsal was being held in the rear of the store. It is supposed that during this rehearsal the robbers entered, went to the safe and took a tray of the goods it contained.

Some empty plush boxes were found in a yard on Boyd St., some time after, but none of the goods have been recovered.

An Alabama Pastoral.

RUSSELLVILLE, Ala., April 1.—In the fire that destroyed almost all the business stores of this town, recently, Hathaway & Frederick, lost twenty-eight watches and other goods valued at \$425.

Four people were arrested on the charge of incendiarism, two of whom, on last Saturday night, were taken from the jail and hung to a line. The remaining two, both negro women, are still in jail awaiting the action of the grand jury.

Another Blow to the Watch Club Business.

ST. LOUIS, Mo., April 1.—The charge of fraud preferred by H. W. Wheeler, of the Dubois Watch Club, of this city, against Charles F. Heller, who, it is said, purchased a watch from Mr. Wheeler worth \$40, paying him \$10 in advance, and after promising to pay the rest in weekly installments, pawned the watch for \$15, was inquired into in the Court of Criminal Correction on Friday. The defendant was discharged on the opinion that the case was not one of fraud, but more one in which the charge should have been embezzlement by the bailee—Heller. Mr. Wheeler's charge was based upon the alleged fact that Heller had given him a fictitious address when he purchased the watch; but this foundation was not deemed

sufficient. Mr. Wheeler did not know what to make of the case which he intended as a test case, but since it had been knocked out as a case of fraud he was rather nonplused.

An Optician's Eyes Played With.

BURLINGTON, Ia., April 2.—George Birney, a traveling optician from Wapello, this State, came to the city a few days ago, with his little satchel and \$57 in cash. On Monday afternoon he was quietly approached by a stranger, who, after glancing carefully around, struck Mr. Birney in the eye with his fist and ran away.

Supposedly, the assailant carried Mr. Birney's \$57 with him, as they have not since been found, though the highwayman was captured a few moments later. Mr. Birney swore in the police court yesterday morning, that he saw the man put the money in his mouth just as he turned to run. The defendant was given twenty days at hard labor.

A Connecticut Jeweler Assigns.

HARTFORD, Conn., April 2.—A. F. Springer, manufacturing jeweler at 23 Asylum St., has assigned to E. G. Lewis. The liabilities are about \$6,000.

A hearing on the appointment of a trustee will be held in the Probate Court, Monday.

A New Fact in the Gloversville Burglary.

GLOVERSVILLE, N. Y., April 1.—R. P. Anibal, council for James Donovan, states that an appeal will be taken. This is thought unlikely, as the cost of preparing and printing would be about \$500. The judge has directed the drawing of a panel of forty jurors for the special or adjourned term in May, for the trial of McAveney, the pal of Donovan's, who is now in jail. The jury was drawn.

A rather astonishing fact was brought to light Friday. About the time of the Norton burglary, the safe in the jewelry store of Yale & Dillon was also tried, and the burglars succeeded in making a hole in the back of it. The face stood exposed to the street, while the back was through a partition—a complete screen. The safe was a large one and well

filled at the time, but no goods were taken nor was the safe opened.

It will be remembered how late the Norton burglars were in getting out of town—after daybreak. It is thought their intent was to secure the booty from both places at the same time, but they missed their calculations, and their late departure was one of the means of tracing and arresting and convicting them. Yale & Dillon kept the matter quiet till Friday.

The Affairs of the McBride & Marcellus Co.

CLEVELAND, O., April 3.—G. H. Gardner on Monday sued D. H. McBride and C. S. Marcellus for \$3,000 on a note signed by McBride and Marcellus, D. H. McBride and C. E. Marcellus, dated Jan. 13, 1890, payable in thirty days. An order of attachment was issued to the sheriff to levy on Mr. Marcellus' equitable interest in a piece of property fronting sixty feet on Doan St.

The motion to make D. H. McBride, Sheriff Ryan and others connected with the levy made by J. W. Penfield on the McBride & Marcellus stock, show cause why they should not be attached for contempt was overruled by Judge Noble on Tuesday.

Creditors of the McBride & Marcellus Co., representing over \$1,000 in debts, have petitioned the Probate Court for the removal of James Gibbons, assignee, and the election of a trustee in his place. The action of the Court of Common Pleas in refusing to continue Receiver Campbell threw the trust into the hands of the assignee, the company having assigned subsequent to the levy on J. W. Penfield's cognovit note and O. E. Campbell's appointment as receiver.

Attorney F. E. Dellenbaugh says that there is not a particle of objection to Mr. Gibbons, except that he is not a practical jeweler. The applicant creditors desire that a jeweler shall administer the trust.

The same creditors that now want a trustee are those who fought for the continuance of the receiver and upheld Mr. Marcellus. The McBride faction is back of the assignee and will undoubtedly fight for him.

Receiver Campbell, of the McBride & Mar-



This cut represents our new **"WHITTIER BIRTHPLACE"** Souvenir Orange Spoon.

PATENTED, MARCH 3, 1891.

An exact likeness of the place where the poet was born, in Haverhill, Mass.

Made only in Sterling Silver and of good weight.

In all kinds of Spoons and Forks.

DESCRIPTIVE CIRCULAR AND PRICE LIST SENT ON APPLICATION.

H. L. DOLE, JEWELER AND SILVERSMITH,

19 MERRIMAC STREET,

HAVERHILL, MASS.

▲▲▲▲ This design is patented and is the only "Whittier Birthplace" spoon made. ▲▲▲▲

cellus Co., filed his final report and account with the clerk of the Court of Common Pleas yesterday. It is largely a history of the case. Mr. Campbell says that on Feb. 23, before he assumed charge of the branch store in Akron, someone removed therefrom some \$16,000 in merchandise. The receiver values his services at \$300.

The Trenton Watch Co. Reduce their List Prices.

The Trenton Watch Co. have issued a pamphlet, notifying the trade that they have reduced the price of their movements 6¼ per cent. from the February list. The circular explains that this step was taken in consequence of the action of the New York Standard Watch Co. It appears from the statement that when the Trenton Company were about to issue their February price list, they were visited by an officer of the Standard Company who prevailed upon them to raise the price of their movement to the same level as that of the Standard Company. This arrangement, the pamphlet claims, was broken by the latter concern reducing the price of their product soon after the Trenton Company had sent out their lists containing the advanced prices.

Manager Roberts of the Standard Watch Co., when seen by a CIRCULAR reporter, and shown a copy of the Trenton Watch Co.'s notification said he had heard of it, but was not prepared to speak on the matter. He said, however, that his company would not take any notice of the sheet just now.

A Nova Scotia Dealer Embarrassed.

TORONTO, Ont., April 1.—The *Journal of Commerce*, of this city has the following to say regarding S. C. Hood, Yarmouth, N. S. "M. Hood has not made any assignment for the general benefit of his creditors, but has covered his stock in trade, and horses, carriages, harness, etc., by sundry bills of sale for different amounts, principally to his brothers and father-in-law, to whom it may, perhaps, be assumed he is indebted. These bills were all given about February 1, and

since that time his notes have been going to protest rapidly. The precise amount of his liability is not known, but his creditors are numerous and widely scattered. He was a good, skillful workman, and in a position to do a good business in his shop, if he had stuck to it, and left real estate speculation, horse trading and other transactions alone."

A Distinction in the Plating of Coins.

BOSTON, Mass., April 2.—The Grand Jury for this term of the United States District Court, reported no bill against the Cambridge jeweler who, a short time ago, was before the Commissioner charged with counterfeiting, by gilding a five-cent piece so that it resembled a \$5 gold coin. The evidence showed that the defendant, J. W. Marshea, did the gilding for a customer who wanted it for a watch-charm, and that before the gilding was begun, a hole was made in the coin, and a ring was inserted, so that it might be suspended from a chain.

The grand jury asked for instructions from the court, and Judge Nelson ruled upon the evidence as presented that the defendant was not indictable. Such a ruling, he added, "would not apply to the case of a person who gilded a coin for the purpose of making it resemble a \$5 gold piece and keeps it, where it might be passed."

A Well-loved Salesman Expires.

A. B. Bray, head salesman in the Broadway store of the Gorham Mfg. Co., New York, died last Friday of pneumonia at his residence, 15 E. 19th St. The funeral services were held the next day in the Church of the Messiah, 34th St. and Park Ave., and were conducted by the Rev. Dr. Collyer, a personal friend of the deceased. The establishment of the Gorham Co. was closed all day, and the employes attended the church services in a body. The interment took place in Boston, Mass., on Monday.

A member of the Gorham Co., in speaking of the deceased said to a CIRCULAR reporter "He was the best salesman we have ever known. He did what very few salesmen do

nowadays, make personal friends of his customers. Possessing as he did an abundance of magnetism, he was always a delightful companion and, as Dr. Collyer expressed himself last Saturday, 'he brought sunshine wherever he came.'"

Newark.

The entire stock of Albert Kalisch, 877 Broad St., has been sold at auction.

Optician J. S. Holmes, Jr., has turned real estate broker, though he has not given up his optical business.

The recent jewelry robbery in Jersey City has been traced to Newark crooks, but who these crooks are the police refuse to say. Several detectives from Jersey City visited Newark on Friday.

The souvenir spoon trade in Newark is increasing, and since the publication of the several articles in THE CIRCULAR, many retailers here have put these goods on their counters for the first time.

Officers Wriggins and Bernet, of the Third police precinct, arrested William Wilson, of Chicago, Ill., last week, charging him with stealing a satchel from Benjamin Smith, a New York man, who lives at 44 Murray St., this city. The satchel contained \$150 in jewelry.

As thousands of visitors are soon expected to visit Newark to attend the great International Saengerfest which will be held in July, the Common Council have been urged to have street signs placed on the street corners. Alexander Milne, of the firm of A. Milne & Co., 61 and 63 N. J. R. R. Ave., has been given a contract to furnish the city with two thousand of these signs at a cost of thirty-five cents each.

A. L. Spear, a well-known citizen of Baltimore, Md., died suddenly at his home last week in the sixty eighth year of his age. He was a leading jeweler of that city, and was a Past Grand Master and the present Grand Treasurer of the Grand Lodge, I. O. O. F., of Maryland.

Washington's Headquarters Souvenir Spoons.

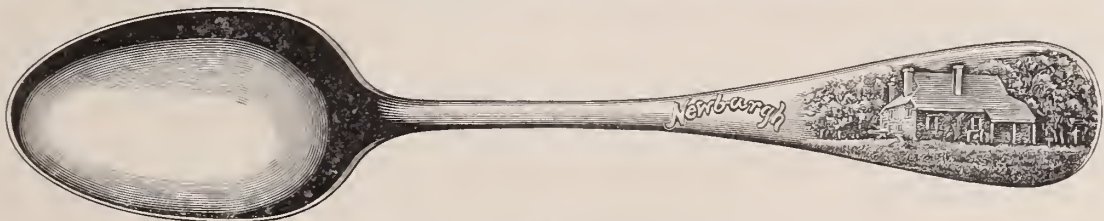

REGISTERED TRADE MARK, JANUARY 27, 1891.

A novelty in Souvenir Spoons. In design an exact reproduction of WASHINGTON'S famous HEADQUARTERS at Newburgh, N. Y. No collection complete without this Spoon. Made in heavy Sterling Silver and sold only by W. H. LYON, JEWELER, 45 WATER STREET, NEWBURGH, N. Y. Made in the following articles and sent to any address on receipt of price.

Coffee Spoons, Silver Bowl.....\$1 25	Orange Spoons, Silver Bowl.....\$2 00
Coffee Spoons, Gold Bowl..... 1 50	Orange Spoons, Gold Bowl..... 2 25
Tea Spoons, Silver Bowl..... 1 75	Sugar Spoons, Silver Bowl..... 3 25
Tea Spoons, Gold Bowl..... 2 00	Sugar Spoons, Gold Bowl..... 3 50
Butter Knives.....\$3 75.	

DISCOUNT TO THE TRADE.

Pacific Coast Notes.

K. C. Naylor, San Diego, Cal., has removed to his old quarters, 835 5th St., and has put in a new stock.

J. P. Borthwick, Ontario, Cal., recently erected a fine new regulator clock in front of his place of business,

M. S. Sawyer, Santa Rosa, Cal., is a lover of bicycling, and President of the Santa Rosa Wheelmen's Association.

A. P. Winslow, jeweler, of Montesano, Wash., is the owner of a magnificent collection of gold, silver, copper and iron bearing quartz, from some of the most famous mines of the United States.

The store of Charles Ball, Chico, Cal., was burglarized last week of goods valued at \$500. The burglars made an entrance in the rear of the store while Mr. Ball was at supper. A small hole was cut in the door, and the bolt was then easily slipped.

The Chicago Watch Co. were recently incorporated at Tacoma, Wash., with a capital stock of \$30,000 for the purpose of conducting an instalment business in watches, jewelry, etc. F. L. Holmes is president, G. A. Treadwell, vice-president and M. J. Morley, secretary and treasurer.

On March 27th, a daring robbery took place at Spokane Falls, Wash., in broad daylight. The head salesman for J. Ryan & Co. locked the store for a few minutes, to go to dinner. While he was absent, a burglar forced the heavy doors, hastily selected jewelry to the value of \$1,000, and escaped.

At Fairhaven, Wash., the other night, a daring burglary occurred at Warner & Jefferey's jewelry store. One of the firm and two other gentlemen were sitting by the stove, twenty feet from the show window, when a robber fastened the door on the outside, by thrusting a stick through the latch handle; he then smashed the window, and grabbing a handful of diamonds, escaped.

Connecticut.

The auction sales of C. G. Earle and Mrs. A. D. White are proving successful.

Gen. G. H. Ford begins next week the alterations of the business block at New Haven which he recently purchased.

Reports from Mr. McAlpine, New Haven, now in Southern California for the benefit of his health, state that he is improving.

C. J. Monson, who closed out his jewelry business here a year ago has gone to Redlands, Cal., to visit his son C. J. Monson, Jr.

R. N. Johnquest & Co., Ansonia, have contributed an elegant marble clock for the big fair of the Foresters, soon to be open in that town.

Mr. Woodward, for several years a popular junior salesman at Geo. H. Ford's, New Haven, has accepted a position as a traveling salesman for the Derby Silver Co., his territory being principally in New York State.

The business at 363 Main St., Bridgeport,

of S. R. Tomlinson has been purchased by S. R. Tomlinson, Jr., and Samuel Coxeter, who have just taken possession under the firm name of Coxeter & Tomlinson.

The Cheshire Clock Co., Cheshire, or rather the bondholders, get \$750 for the machinery, buildings and land. This will probably all be taken for expenses. The bonds were \$25,000 and the stock \$40,000.

The pearl recently found in an oyster shell by Edward Malley, New Haven, while taking dinner, has been superbly mounted by Tiffany & Co., New York, into a scarf pin. It has been polished and has developed a more valuable jewel than was first supposed.

The Waterbury Clock Co., Waterbury, are having plans prepared for a large brick addition to their works. The new building will be five stories high and 69x101 feet. There will be a tower in front, 19 feet square, with a high mansard roof. The tower will be surmounted by a flag-pole and will contain the stairways, elevator and toilet-rooms. The interior will be finished in native woods.

President Hiram Camp, of the New Haven Clock Co., realizes to a considerable degree the extent of the importunities which beset benevolent men of wealth. Hardly a day passes without he has many applications through the mail for alms, or for donations, to say nothing of personal applications. Being a liberal benefactor to religious and charitable enterprises and having given largely to Moody's school at Northfield and erected a church at his own expense, his generous disposition is well known. But some of the applications he has received by mail have tickled President Camp's lively sense of the humorous, while also causing him to regret that he is not a Cræsus. For instance he received lately letters from persons in Ireland, appealing to him to pay off the mortgages on their farms, the applicants being parties he had never before heard of; and in a recent batch of letters asking for aid was one from a New Haven mother, who having heard of his kind heart asked him for a donation of a piano for her daughter.

Utica.

C. H. Schiller has introduced birthday rings, into this city, and his sales are quite large.

Kirtland & Gilmore are preparing to move to their elegant new store, at 166 and 168 Genesee St.

B. F. Davies, 5 Devereux St., has been selected by the newly organized Common Council, to keep the city clocks. This is a proper recognition of Mr. Davies' skill.

The Easter display in the windows of the store of J. Wineburgh & Sons, 32 Genesee St., was decidedly novel and attractive. It was commented on by all the local newspapers.

G. H. Evans, of the firm of Evans & Sons, has, in company with E. A. Dewhurst, just issued the initial number of the "Christian Endeavorer," a paper in the interests of the

well known Y. P. S. C. E. movement. In connection with this statement it might not be out of place to say that among Utica's jewelers, a large number are actively engaged in Christian Endeavor work.

Lancaster.

W. W. Appel, Hamburg, this State, was here this week, making arrangements for the removal of his store to this city next week.

Twenty-two hundred watch movements of the Lancaster Watch Co., were sold by Ellis & Shaw, auctioneers, at the Philadelphia Exchange, last week.

C. M. Musselman, who has been connected with Ernest Zahm for some years, was last Tuesday presented with an elegant gold watch, by his friends.

R. W. Simpson, Jr., of Wm. Riker, New York, who was in this city this week, is just recovering from a serious attack of illness. He was confined to his bed for four days in St. Louis, Mo., and four days in Memphis, Tenn.

H. J. Cain, formerly manager of the Lancaster Watch Co., but who is now interested in the Aurora Watch Co., was in the city this week. He declined to make known the object of his visit, but it is supposed to be in connection with the coming sale of the Lancaster Co.'s effects.

M. Gattle, of Falkenau, Oppenheimer & Co., New York, who was in the city this week, is just recovering from a prolonged illness. Among the other traveling men in the city last week were: S. Aronsberg, of John Scheidig & Co., S. G. Walmsley, of Tenner & Baum, and E. Jacobson, of Jacobson Bros., New York.

Canada and the Provinces.

Montreal jewelers say that this year's crop of Easter wedding presents, was considerable above last year's.

F. Stirskey, New Westminster, B. C., who was recently burnt out, has re-opened temporarily in the Colonial Hotel Block.

Thos. Davidson, formerly a prominent jeweler of Hamilton, Ont., has changed his quarters to Montreal, P. Q., where he is the superintendent of Henry Birks & Co.'s jewelry establishment.

The Roman Catholic Cathedral at St. Henri, a suburb of Montreal, P. Q., has placed in its tower a clock valued at \$13,000. It is lighted by electricity at night. A Montreal firm are the manufacturers.

Last week the second case against Macdonnell, charged with the theft of jewelry from G. E. Jacques store, Calgarry, Man., was tried and he was sentenced to four months' imprisonment at hard labor.

An attempt was made last week to enter the store of F. Crumpton, 83 King St., Toronto, Ont., but was not successful. A

number of holes were bored through the door and the lock forced, but not sufficiently to gain an entrance.

H. Brassler has reopened his jewelry store in Rockel's stand, Waterloo, Ont.

Geo. Chillas, Toronto, Ont., has gone on a trip to the maritime provinces.

J. Mallett, Brandon, Man., has opened a new jewelry store at Louris, Man.

C. H. Gilpin, has given up his business at Newmarket, Ont., and moved to Chicago, Ill.

Wm. Eaves, Montreal, P. Q., has just returned from a fortnight's business trip to New York.

The jewelers of St. Stephen, N. B., have decided to close at 6 o'clock on Mondays and Tuesdays.

O. H. Bouter, Trenton, Ont., has opened a new jewelry establishment on Dundas St., in that town.

Louis Davis, of Louis Davis & Co., Montreal, P. Q., has just returned from a trip to the English markets.

C. W. Minor has bought out Mr. Pennock's interest in the firm of Pennock & Kingham, Victoria, B. C.

J. H. Jones, Montreal, P. Q. was confined to his house for over a week through illness, but is around again, fully recovered.

A. A. Abbott, manager of Smith & Paterson's Montreal branch, made a flying visit to Boston, Mass., last week on business.

W. C. Balcom, a jewelry dealer, was at Molega gold mines just after the recent dynamite explosion, which injured several people.

C. H. A. Grant, of the American Watch Case Co., Montreal, P. Q., returned to that city on Tuesday night, from an extended trip through the maritime provinces.

At about two o'clock on Friday morning a stone was thrown through the windows of H. J. Dreyfus' store, 171 St. Lawrence St., Montreal, P. Q. The noise brought Messrs. Aumond and Lassalle, night watchmen, to the spot and the thief escaped before he had had time to take much plunder. The jewels stolen were worth about \$40. The window, although a complete wreck, was fully insured. The detectives are working at the case.

Columbus.

A new store has been opened on E. Long St., near Grand Ave.

G. W. Luce is selling out his stock of watches at cost, prior to moving into other quarters.

Kleeman Bros. have opened another store at 177 S. High St. They are now conducting three stores in this city.

W. S. Creighton, the Governor's executive clerk, has an open face, heavily carved double case, English lever gold watch, beating quarter minutes, which was presented to his uncle, Wm. Creighton, the first Secretary of State of Ohio, at Chillicothe (the old capitol), in 1802. Mr. Creighton left it at F. F. Bonnett's store last week for repairs, and it still keeps good time.

Springfield, Mass.

The Charles S. Saxton Co., have been holding a successful special sale of diamonds.

C. D. Rood is still at his home in this city, and devote most of his time to the affairs of the Aurora Watch Co.

Springfield dealers were a little slow in getting out souvenir spoons, but now they all have them, and the trade in them is excellent.

C. Rogers, the optician, who has for ten years been in business at 341 Main St., has just moved to a much better store at 451 Main St., opposite Court Square. Mr. Rogers has fitted up his new store in a very attractive manner and will keep a larger line of goods than heretofore. He has a larger workshop, and better facilities for executing particular and delicate cases.

San Francisco.

Geo. C. Shreve & Co. do not expect to locate in their new quarters in the Crocker Building before the Fall.

The city is overrun with travelers for Eastern houses, but they are all smiling and happy, and are evidently doing some business. Max Kling, New York, is one of the recent arrivals.

John Roach, a well-known optician, died last week, after a brief and painful illness. The deceased was probably the oldest optician west of the Mississippi river, having been in business here for over forty years. He was one of California's pioneers, and one of the best beloved and highly respected citizens in the State. The bulk of his estate will fall to his devoted sister, Miss Maria Roach.

Cleveland.

Webb C. Ball is getting out a Garfield and a Cleveland souvenir spoon.

Last week thieves stole jewelry from F. Brown, 572 Ontario St., worth \$35.

The trustee of Sumner Brothers was authorized by the Probate Court on Thursday to advertise the public sale of their stock.

J. G. Adams, alias Tower, has waived examination before Judge Kelly, and has been bound over to await the action of the grand jury in \$500 bail.

Sipe & Sigler have donated an elegant silver cup valued at \$250, to be contested for by the marksmen of Cleveland and vicinity. Mr. Sigler is himself an expert trap shot.

One of the most beautiful Easter windows in Cleveland this year was that of Webb C. Ball. The lower half of the window was partitioned off, draped in lavender and trimmed with violets, which formed the words, "Easter Greeting."

Webb C. Ball will not occupy the entire building which he has just leased. Twelve feet will be added to his own on the ground floor and the fourth floor will be used for manufacturing and repairing purposes. The remainder of the building will be rented.

The officers and directors of the C. B. McElroy Jewelry Mfg. Co., incorporated last August, not giving entire satisfaction to the principal stockholder, C. B. McElroy, the latter had the amount paid in by them returned and new officers elected. These are C. B. McElroy, president and treasurer, A. A. Bemis, vice-president, T. W. Minshall, secretary, W. Bind and W. Diebold, directors.

John Harris, alias Considine, who was fined \$200 and costs for an attempt to rob A. D. Ernie & Co.'s store was released from prison Friday afternoon, his fine having been paid. He was immediately rearrested on a warrant charging him with the robbery of E. L. Wilsdorf's store on Feb. 6. He was arraigned on Saturday. Although identified by both Mr. Wilsdorf and his clerk the Judge did not consider the evidence sufficient to hold him.

Providence.

C. Duckworth has returned from a visit to New York.

W. L. Tobey, corner Elm and Butler Sts., is out of business.

N. B. Barton, of Ostby & Barton, visited New York last week.

The Howard & Son Co. closed down Saturday last for one week.

E. S. Luther, of E. S. Luther & Co., was in New York the past week.

J. A. McCloy has been appointed a District Deputy of the United Workman.

Nelson Davis, with J. W. Grant & Co., has just returned from a successful western trip.

Arthur Stone has moved into his summer residence at Shawomet Beach for the season.

Frank Miner has started in business at 14 Page St., in the shop formerly occupied by Cole & Taylor.

S. A. Smith, of the Gorham Mfg. Co., has been elected to the executive committee of the Advance Club.

A. H. Richmond is once more on the road, after his recent illness, in the interests of B. E. Daggett & Co.

C. S. Smith, A. E. Austin and E. N. Cook, have been elected to membership in the Young Republican Club.

H. S. Dorchester has been elected as a member of the school committee from the Sixth Ward on the Republican ticket.

Ralph Hamilton, Jr., was one of the aids to the floor manager at the Spink reception, in Infantry Hall last Tuesday evening.

W. J. Smith, 16 Page St., has decided to make Chicago his future residence, and will remove his factory to that city in a short time.

C. W. Grube has been elected foreman of Narragansett Engine Co., of Riverside, and treasurer of the Riverside Social Club, of the same place.

The following jewelers have been appointed aid-de-camps to the department commander of the Grand Army: J. A. Vaughn, G. B. Willis and E. F. Seery.

J. H. Fanning has been elected vestryman, a member of the music committee and a delegate to the Diocesan Convention, by St. James Episcopal Church.

Albert Eddy, of Albert Eddy & Co., who has been confined for several weeks with pneumonia, is now able to be at his office a short time each pleasant day.

Among the jurors drawn for the April term of the Supreme Court are the following jewelers, 1st class, A. E. Austin and Phillip Linton, 2d class, S. L. Lederer.

A number of gentlemen of Edgewood, recently met at the residence of D. F. Adams, and organized the Edgewood Casino Association, with D. F. Adams as vice president.

C. G. Bloomer was one of the committee of three appointed by the Rhode Island Yacht Club to draw up resolutions upon the death of Commodore J. Lawless, of that club.

J. T. Hunt, formerly with John T. Cuddy & Co., has hired seats of John Moore & Co., 135 Ely St., for the purpose of getting out a line of samples preparatory to starting in business.

A. W. Stanley, G. A. Forsythe and G. H. Fuller were among the guests at the recent complimentary banquet of Tower Light Infantry, at Capt. G. W. Easterbrook's, at Pawtucket.

The large brick building known as the Sackett & Davis building, corner Friendship and Richmonds Sts., will have no power

during the last week in this month and first week in May, on account of the putting in new boilers, the present one having been condemned. This will necessitate the closing down of Foster & Bailey, Martin, Copeland & Co., and Thomas Quayle & Co.

C. R. Smith, of the C. R. Smith Plating Co., is contemplating a trip to Europe in the near future in the interests of his concern. He will probably be accompanied by other members of that corporation.

Henry Read, manufacturer of silver jewelry, 40 Potter St., whose failure was recently given in this column, is now offering his creditors 25 cents on the dollar. It is understood that this offer is being quite generally accepted.

The R. N. Hershfield Jewelry Co., Kansas City, Mo., have been sued by the Kent & Stanley Co. for a bill of about \$400. Mr. Hershfield claims that the bill has already been settled, and the matter now stands in abeyance.

Among the recent foreign importations into this city, the total value of which is \$18,481, were ten packages of candelabras from Liverpool; three packages of imitation precious stones from Bremen and one package from Havre.

The firm of J. B. & S. M. Knowles having been dissolved by the decease of J. B. Knowles, the business will be carried on by the J. B. & S. M. Knowles Co., at 95 Pine

St., as heretofore. S. M. Knowles is president and W. C. Burwell, treasurer of the company.

Omaha.

U. J. Welsh, who had charge of the material department of Sol Bergman & Co., is no longer in their employ.

Max J. Baehr and Mr. Michaels, have recently left the employ of Max Meyer & Bro., with whom they have been connected for some time.

About the middle of May, A. M. Holzheimer & Co., expect to move from their present quarters into the handsome building which is going up on the corner of Douglas and 16th streets.

C. S. Raymond leaves for the East this week to purchase fixtures for his new store. Workmen are busy raising on the now vacant spot of his old store, a fine structure which will before long be ready for occupancy.

J. R. Frenzer is just getting out a very handsome set of spoons made from rare and ancient coins. In a different line was a bon-bon spoon with a handle of round wire, tipped with a fleur de lis head, at the base of which was a tiny, sparkling diamond.

Walter Sams, lately of the Sams Jewelry Co., has opened a store at 107 S. 16th St. He makes a specialty of watch work. The Sams Jewelry Co., are located at the same number. They removed from the Barker Block, corner of 15th and Farnam Sts.



The most desirable line of 16-size movements on the market.

Boston.

C. E. Mudgett, of Fairfax, Vt., was in town last week on a buying trip.

Herbert Richards has returned from a pleasure trip to Savannah, Ga.

E. A. Whitney took a holiday run over Fast Day to his old home in Ashburnham, this State.

One of the Easter designs shown this year which had a large local sale was a small silver scarf-pin in the shape of a calla lily.

Salesmen from New York here last week were, George Osborne, of William Smith & Co., Mr. Block, of W. & S. Blackinton, and Fred Clarkson of Snow & Westcott.

L. W. Sweet, of the Cheshire Watch Co., was in town during the past week, and accepted an invitation from D. C. Percival for a fishing trip to Sandwich, Mass.

C. D. Place, 23 School St., will move on April 15th to the quarters just vacated by A. H. Potter & Co., in the store of J. N. Lindsay & Co. Extensive alterations are now being made in the store front, and handsome display windows will be put in.

New Bedford.

A. R. Brightman, formerly with C. W. Haskins, has accepted a position with P. Gottesleben & Son, Denver Col.

Among the recent arrivals were Albert Walker, Providence, Fred Clarkson, of Snow & Westcott, and R. T. Supple, of New York;

C. W. Findlay, of A. Paul & Co., Boston, Mass.

On Saturday, Antone and Joseph Percida were arrested for stealing a watch valued at \$24 from D. J. Sullivan, 136 Union St. They were later fined \$50 each.

J. A. Dexter and J. T. Tobey, who occupy stores directly opposite one another on Purchase St., are suffering from a raise in rents. It seems that certain parties are seeking a location on Purchase St. for a liquor saloon and they approached the owner of the building in which Mr. Dexter's store is located and made such flattering offers him to that he immediately raised the rent from \$400 to \$600. Mr. Decker refused to pay the advance and gave notice that he would vacate about April 1st.

Mr. Tobey's landlord who is a lessee, was tempted by the same parties, and notified the jeweler to move. Just as he was about doing so, however, the owners of the property came down upon him and refused to allow the location to be used for a saloon. Mr. Tobey will therefore remain, but his rent is doubled in view of the recently added plate glass windows.

G. F. Kunz, of Tiffany & Co., sailed last Saturday on a trip to Asia and Africa, in search of minerals. He will be absent about six months and expects to return with a valuable collection.

The Attleboros.

Aubrey Cox has accepted a position as salesman for the Mason Jewelry Co.

The new firm of Bell & Cobb, are putting in machinery and will soon be ready for business.

The shop formerly occupied by D. F. Briggs, is being repaired and fitted up and will be used by Stanley Brothers.

E. E. Barrows and J. H. Totten have been elected delegates to attend the Episcopal convention at Boston, on April 28 and 29.

Paul Bertin, designer for Wade, Davis & Co., has severed his connection with that firm and taken a position with S. E. Fisher & Co.

J. F. Stanley, Walter Trescott and E. C. Stanley started Thursday for Plainfield, Conn., where they will spend a couple of weeks trout-fishing.

An adjustment in the loss by the recent fire in the small building occupied by John Hugo, was made Wednesday. It is understood that the full amount of the policy was paid.

The business at the jewelry shops the past week has been very dull and the stranger to this town would have thought that everyone was idle, so many unemployed men and girls were seen on the streets. At a few of the shops about two days work was done, but the majority have been idle all week.

PHILADELPHIA**SOUVENIR  SPOONS.**

A FINE ASSORTMENT

OF THE

MOST ARTISTIC AND SALABLE DESIGNS.**DAVID F. CONOVER & CO.,**

SEND FOR SELECTION.

PHILADELPHIA, PA

SOLID SILVER COFFEE SETS.



AFTER DINNER

COFFEE POTS.

ODD AND UNIQUE DESIGNS.



TURKISH, MOORISH

AND OLD ENGLISH

DECORATIONS, WITH SUGAR DISH,
TONGS AND TRAY TO MATCH.



GORMAN MFG. CO.,

SILVERSMITHS,

Broadway and 19th St.,

NEW YORK.

ALFRED H. SMITH & CO.,

DIAMONDS,

182 BROADWAY,

COR. JOHN STREET,

NEW YORK.

33 HOLBORN VIADUCT, LONDON, E. C.

THE JEWELERS' CIRCULAR AND HOROLOGICAL REVIEW.

PUBLISHED EVERY WEDNESDAY BY

THE JEWELERS' CIRCULAR PUB'G CO.,

AT NO. 189 BROADWAY, NEW YORK CITY.

A JOURNAL DEVOTED TO THE INTERESTS OF WATCHMAKERS, JEWELERS, SILVERSMITHS, ELECTRO-PLATE MANUFACTURERS AND ALL WHO ARE ENGAGED IN KINDRED BRANCHES OF INDUSTRY.

Terms of Subscription, Postage Prepaid.

	PER ANNUM
United States and Canada, - - -	\$2.00
To all Foreign Countries, - - -	4.00
Single Copies, - - - - -	.10

ADVERTISEMENT.

Business letters, drafts, checks and post-office orders should be addressed to THE JEWELERS' CIRCULAR PUBLISHING COMPANY, No. 189 Broadway, New York city.

Manuscript from any quarter containing news or discussion of any technical subject within the field covered by THE CIRCULAR will be welcomed. Matter received that proves unsuitable or unavailable will be returned if accompanied by the necessary postage stamps.

Our editorial columns will contain our own opinions only, and we shall present in other columns only what we consider of interest or value to our readers. Applications to print advertising matter as news will not be considered.

Advertising rates in THE CIRCULAR are lower, considering the number of tradesmen reached by its large circulation, than in any other jewelry journal.

Notices of changes in standing advertisements must be received one week in advance, new matter can be received up to Saturday.

Member of the American Trade Press Association.

CLASSIFIED INDEX TO ADVERTISERS, PAGE 28.

VOL. XXII. APRIL 8, 1891. No. 10.

Spread the True Fashions. OUR exchanges show that numerous jewelers are carrying out our petition to them to have the fashions in jewelry contained in THE CIRCULAR reprinted in their local journals. The advantages of these republications as a check against the broad assertions of misinformed reporters and writers have been made plain to the trade through these columns. It is to every jeweler's interest that the public have an authentic idea of what is being worn in jewelry, and this THE CIRCULAR can furnish.

The Pulse of the Optician. NO industry needs organized action against commercial abuses more than do the jewelry and kindred trades; and no branch of the industry perhaps, needs it so much as the optical trade. What with the self-styled professors and eye-specialists, the itinerant dealers in spectacles and eye-glasses, and the army of untaught and unskilled practitioners swarming the country villages, the pub-

lic, who have too often been hoodwinked or misled, do not regard the optician's craft in the light that its scientific basis should warrant. This misapprehension is recognized by all legitimate opticians and during the past three months, many of them have expressed themselves forcibly on the matter of organization. In fact a number of the more energetic have founded the American Association of Opticians, the object of which is to place the members in a position to increase their technical knowledge, discuss their mutual interests and in the end alleviate themselves from some of the abuses that assail their profession. The organization which commenced with a limited membership is constantly growing and is receiving encouragement from some of the largest optical houses in the country. The bi-weekly meetings are proving of much benefit to the members. At present, owing to the limited membership, the benefit is intellectual rather than commercial. To weed out the abuses that menace the profession, the membership of the Association must reach into the hundreds or thousands, if possible. Every optician should have his name added to the membership of the Association. As an experiment, the scope of the organization seems satisfactory; if any errors are being committed, the larger the membership, the more suggestions for reform are possible. Let the organization be one for hard work, one for mutual improvement, both intellectual and commercial. With an extended membership and this platform, the standard of the profession must be raised. The social side of such an organization must not be forgotten, but this is a minor consideration in comparison with the other two.

World's Fair Exhibits. ALREADY jewelers and opticians have begun to think of making displays at the World's Fair to be held next year in Chicago, and none too soon, for the intervening time will rapidly slip away and the exposition be upon us almost before we are aware of it. It would be well for the jewelry and horological trades of this country to be well represented. None of the old countries can compare with this younger one in the manufacture of clocks and watches. Then all, from the massive and costly tower clock to the low priced and accurate Waterbury watch, should have a distinct and prominent place somewhere under the great roofs where the productions of the entire world will be gathered. In solid silverware, and in plated ware also, the United States can compare creditably with any other country. These goods, too, then, should have a place. Let the scions of ancient house, who boast of many pounds, or even hundred-weights of plate, descended through many generations to their present owners, see what we can do here and learn what every man of even moderate means in this country can place upon his side-board at a comparatively small expense. But the excellence of our workmanship is not confined to these two branches

alone; in beauty of jewel settings, in ingenious devices, in patentable improvements we are not behind other countries, and all this should be brought out in this exposition. So let no one lag. A good showing means an increase in both domestic and export trade and any money invested in the manufacture and exhibition of a good article will certainly give a large profit in return.

The Week in Brief.

R. Bertchy, Memphis, Tenn., accepted a bogus check—A noted crook, as a watchmaker, was arrested in Galveston, Tex.—Burglars robbed the safe of A. Walter & Son, Jersey City, N. J., of \$3,000 worth of goods—Custom authorities at Victoria, B. C., seized a jewelry store—The Elgin Clock Co. were incorporated at Elgin, Ill.—Burglars robbed the stores of Ellis Bros., Bedford, Ind., Peifer & Reed, Oaktown, Ind., and Bartlett Bros., Los Angeles, Cal.—The Illinois watch factory narrowly escaped a fire—G. W. Smith, a Kentucky jeweler, is in trouble—Some ghastly finds at Montreal, P. Q., were thought to be of the missing jeweler, Swenson—A decision was rendered against the Dubois Watch Club at St. Louis, Mo.—A. F. Springer, Hartford, Conn., assigned—New facts developed in the failure of the McBride & Marcellus Co., Cleveland, O.—An interesting decision was rendered at Boston, Mass., regarding the plating of coins—A. B. Bray, of the Gorham Mfg. Co., New York, and A. L. Spear, Baltimore, Md., died—The stores of C. Ball, Chico, Cal., and Warner & Jefferey, Fairhaven, Wash., were robbed—The Waterbury Clock Co. will erect an additional building—The window of the store of H. J. Dreyfus, Montreal, P. Q., was smashed—John Roach, San Francisco, Cal., died—The J. B. & S. M. Knowles Co. were incorporated at Providence, R.I.—The New York Jewelers' Association were incorporated—The suits against the judgment creditors of Stern & Stern, New York, were decided against the plaintiffs—Motion was made to set aside the transfer made by E. R. Kant, Cleveland, O.

Short in His Accounts.

CHICAGO, Ill., April 4.—Several days ago H. Muhr's Sons, Philadelphia, Pa., advocated the resignation of their Chicago agent, Joseph Sandman, who in two years' service leaves a shortage behind him of \$5,000. While this has not yet been paid, it is said that Mr. Sandman's financial affairs will be straightened, and no criminal prosecution resorted to. The first intimation of any possible misdeed was when Mr. Sandman confided to a few personal friends shortly after his connection with H. Muhr's Sons, that he had lost sight of \$3,000 worth of diamonds, which he concluded had been stolen either from his office or his pocket. The knowledge of his shortage came from a man to whom Mr. Sandman had confided that he was \$5,000 short.

G. Armeny has entered a judgment for \$120.67 against Emil Rinderman.

Julius Heilbronn, of Heilbronn & Blank is expected home next week on *La Normandie*.

F. M. Jones was in Chicago last week in the interest of the Jewelers' Security Alliance.

Sanford & Cook have been admitted into the membership of the New York Jewelers' Association.

Edmund Heinecke, of 29 E. Houston St., and 152 E. 125th St., has given a bill of sale to S. F. Myers & Co. for \$350.

On May 1st A. Newberger, who for over twenty years has been established at 531 Sixth Ave., will move to 1245 Broadway.

M. F. Harris, for four years connected with Charles Jacques, and H. M. Davis have been admitted into the firm which is now Charles Jacques & Co.

On complaint of Julius White, 363 7th Ave., Thomas Benjamin, a young man living at 152 W. 32d St., was held for trial last Friday on the charge of stealing a silver watch.

E. V. Clergue, New York, agent of the E. Howard Watch and Clock Co., starts this week for New Orleans and will from there proceed to San Francisco and other points on the Pacific Coast.

Yesterday afternoon auctioneer W. B. Norman began a sale of jewelry, watches, miniature clocks and silverware at 240 5th Ave. The goods are part of the stock of George A. Glaenger & Co.

Henry Lorient, clockmaker, 130 Fulton St., returned from Europe last week and on visiting his establishment was gratified to find his second pension papers awaiting him. Mr. Lorient served through the late war.

Next Monday, Lawyer G. C. Comstock as attorney for Waterman & Lehmann, will make a motion in the Court of Common Pleas to remove E. C. Heizman as assignee in the failure of his father, Charles Heizman, 459 3d Ave., and for the appointment of a receiver.

Rudolph Brettner, 64 Nassau St., last Saturday caused the arrest of a young woman named Fannie Ginsberg, on a charge of stealing a pair of diamond earrings, valued at \$120. The woman, who claimed the trinkets were given to her, was held in default of \$1,000 for trial.

Adolph Ruduziner, 332 Grand St., last Saturday charged Joseph Sundberg with stealing a \$100 check from him. The arrest was the result of a money-lending transaction, and Justice Meade, of the Essex Market Police Court, before whom the case was tried, discharged Sundberg.

The New York Jewelers' Association last Saturday filed articles of incorporation with the Secretary of State. The names of the trustees are as follows: H. E. Ide, Ludwig Nissen, W. L. Sexton, F. H. Webster, N. H. White, B. H. Knapp, W. R. Alling, F. H.

Larter, H. H. Butts, J. G. Bacon, G. W. Shiebler and G. C. White.

Charles Bailey, one of the men constituting the Chicago Watch & Jewelry Co., who are charged with using the mails for unlawful purposes in conducting an alleged watch lottery, was tried before Commissioner Shields last Wednesday. Decision was reserved. The other defendants were remanded.

Some time ago, the New Haven Clock Co., brought suit in the New York Courts against Robert Hubbard, Kingston, N. Y., for \$95, the value of goods sold and delivered. Last Monday the defendant's counsel made a motion before Judge Patterson, in Supreme Court Chambers, to change the place of trial from New York County to Ulster County. His Honor took the papers, and reserved his decision.

E. A. Thrall arrived home from his Euro-

pean trip last Thursday and brought with him several antique pieces of jewelry gathered at various ancient cities. T. B. Bensel, who dresses the windows of the stores, outshone himself in his endeavor to celebrate his employer's return. In the centre of an oval formed by the words "Welcome Home" in white cotton dotted with violets, rested a black pad with "E. A. Thrall" consisting of diamonds and emeralds.

Some months ago Richards & Rose, of Dubuque, Ia., failed. The business was conducted by Mrs. Richards and Mrs. Rose, and a short time ago the husband of the former died and left an insurance policy for \$10,000 in the Equitable Insurance Co., in favor of his wife. Last Saturday Lawyers Hays & Greenbaum, acting for J. T. Scott and several other creditors of the firm, attached the insurance money on claims aggregating \$1,033.65.

JEWELERS ATTENTION!

DO YOU KNOW that we are making the only line of cuff buttons which are sold exclusively to the RETAIL JEWELRY TRADE?

DO YOU KNOW that the action or fastening of this button is the simplest, most durable and most salable of any in the market?

DO YOU KNOW that we are manufacturing a full line of these buttons in roll plate, gold front and solid gold?

DO YOU KNOW that this line of buttons was endorsed and recommended by the OHIO RETAIL JEWELERS' ASSOCIATION?

DO YOU WANT a line of cuff buttons which is not found in any Dry Goods, Gents' Furnishing or Millinery Store in the country—thereby preventing such ruinous competition?

Then send to us for a selection of our "**ANTI-SWEAR**" Buttons

J. T. SCOTT & CO.,

SOLE MANUFACTURERS,

4 MAIDEN LANE, - NEW YORK.

CHARLES H. PECKHAM,

Diamonds and Diamond Jewelry,

63 Nassau Street,

NEW YORK.

BUY THE "BARON" SPECTACLE.



The best Periscopic Spectacle in the World for Opticians to sell for \$1.00. Sole manufacturers, LEVY, DREYFUS & CO., 11 Maiden Lane, New York.

Goods Sent on Memorandum.

The partnership between Julius Wodiska and Louis Stirn, under the name of Wodiska & Co., has been disbanded.

Ludwig Lehmann, the manufacturer of jewelry boxes, at 120 Fulton St., whose factory was damaged by fire last week has resumed business.

D. A. Warren, assignee for Morris Herrmann, is advertising for all creditors having claims against Mr. Herrmann to present them to him at the office of W. S. Allerton, 35 Wall St., before June 5.

Among the departures for Europe last week was: G. F. Kunz, New York, on the *Umbria*. E. A. Thrall, New York, arrived on the *Teutonic*. L. Kahn, of L. & M. Kahn & Co., New York, will sail to-day on the *Lahn*.

J. H. Kimball, whose factory at 14 Maiden Lane was burnt out two weeks ago, as related in THE CIRCULAR at the time, resumed work last Monday, having adjusted the affair with the insurance companies, and had the workshop refitted.

A meeting of the creditors of C. T. Seaverns & Co., of Boston, was held in the office of Franklin Bien last Tuesday. There were no matters of importance transacted other than taking such steps as were necessary for the protection of the creditors.

H. M. Condit, of the N. Y. Jewelers' Board of Trade, left for Chicago, Ill., last Saturday, to attend to several matters in the interest of his organization. Before his return he will stop at Cleveland, O., in connection with the Sumner Bros., failure, and at Syracuse, N. Y., to see the representatives of F. D. Enney.

J. H. French, the jewelers' auctioneer, has just closed a very successful sale for M. Panon, 931 Broadway, dealer in fine porcelains, cloisonnés, bronzes and bric-a-brac. On April 7th Mr. French will begin a sale for Baldwin & Co., at the corner of 27th St. and Broadway, dealers in fine leather goods, pocket cutlery, etc.

C. G. Alford & Co., filed articles of organization with County Clerk Samuel Smith, at Newark, N. J., on Monday. The capital stock of the company is \$300,000, with \$200,000 paid in. The factory will be in East Orange, N. J. C. G. Alford, of East Orange, F. G. Thornbury, of New York City, J. L. Clark, of Franklin, N. J., and H. B. Thornbury, also of New York City, are the incorporators.

The Week's Arrivals.

The following dealers from out of town were registered in New York during the current week: C. D. Simpson, Scranton, Pa., H. Normandie; Wm. M. Harding, Boston, Mass., St. Stephens H.; J. Mandelbaum, Hartford, Conn., Grand Union H.; S. B. Lawrence, Boston, Mass., Grand Union H.; F. Buckley, Middletown, N. Y., Morton H.; C. E. Marcellus, Cleveland, O., Astor H.; W. Johnson, Clinton, N. C., Metropolitan H.; Mr. Winder, Troy, N. Y.; J. C. Rapier, New Haven, Ky., Astor H.; W. S. Bigelow.

Boston, Mass., Hoffman H.; H. A. Harrington, Boston, Mass., Astor H.; Mr. Hansell, Hartford, Conn.

Philadelphia.

Louis Sickles, of M. Sickles & Sons, has just returned from a successful business trip.

The Grand Jury has found a true bill of indictment against Lizzie Hutt, charged with the larceny of fancy cutlery valued at \$22.70 from Herman Herder's store, 606 Arch St.

Work has been commenced on the five story addition to the Keystone Watch Case factory. The new building will correspond in appearance with the old one, the brick walls being relieved by marble trimmings. The improvement is to cost \$11,000 and the work is to be completed by May 1.

Eighteen diamond rings, a number of watches and a lot of general jewelry which were smuggled into this port on the Lord Clive by David Squires, some time ago, and which the government officials seized, will be sold by United States Marshal Leeds, at his office on the 18th, at 11 o'clock.

L. P. White, agent for the Dueber and Hampden Companies, has moved from 631 to 706 Chestnut St. The old quarters were found to be inadequate to accommodate the increasing business. He now occupies a room 25 by 90 feet in size, which is filled with clocks and ornaments of a variety of makes and designs, the stock of samples having been greatly increased.

J. W. Reddle, New York, was here during the week, and as it was his first trip for the firm, of which he recently became a member, he took away a number of complimentary orders. Samuel Howland, of Peterson & Royce, New York, was another of our visitors. Among other visitors were Frank Wood, of Carter. Sloan & Co., Louis De Goll, of the Roy Watch Case Co., and Frank Sherry, of Joseph Fahys & Co., New York.

Kansas City.

Mrs. Alexander Nathan, daughter of R. N. Hershfield, died of pneumonia last Sunday afternoon at the home of her parents in this city.

Herman Streicher, 1017 Main St., has applied to the city council for permission to erect an electrical clock before his store. The Joliet Electric Clock Co. will make the time-piece.

The wall of the new store of M. B. Wright & Co., now being remodeled at 1034 Main St., settled several feet a few days ago, delaying the work considerably. The date for occupying the new building has not been fixed.

Frank Bruce was arrested here last Saturday for the burglary of a jewelry store in Omaha some months ago. He was arrested there, attempted to kill a policeman and then jumped his bond. He is known as a clever burglar. While confined here he attempted to saw from his cell. He was taken to Omaha Saturday morning.

DORFLINGER'S AMERICAN CUT GLASS.

The Finest Crystal, Plain and Cut, made in the World.



EVERYTHING that is used in Glass, for the Table.

Sells as well as Silver-ware.

EVERY FIRST-CLASS JEWELER

C. DORFLINGER & SONS,



BEAUTIFUL, Artistic and Useful Pieces for Gifts.

Rivals the Diamond for Purity and Lustre.

SHOULD KEEP IT.

36 Murray Street, New York.

American Morocco Case Co.

FINE EBONY AND ROSEWOOD TRAYS FOR RINGS, WATCHES, ETC.

ONLY MAKERS OF

WHITE METAL CASES FOR RINGS, BROOCHES, ETC.

9 Bond St., N. Y.

HARD WOOD TRUNKS FOR SPOON WORK, ETC.

CLASSIFIED INDEX TO ADVERTISEMENTS.

All Advertisements are entitled to one insertion under proper heading. Extra insertions, \$6.00 per Annum. Extra Headings \$12.00 per Annum.

PAGE.		PAGE.		PAGE.
	Assayers & Refiners.		Horological Schools.	
	Goldsmith Bros., Chicago, Ill..... 47		Elgin Horological School, Elgin, Ill..... 44	
	Howard, S. P., 8 John st., N. Y..... 48		Jaegman, R., St. Louis, Mo..... 29	
	Lelong, L., & Bro., Newark, N. J..... 48		Waltham School of Horology, Waltham, Mass. 40	
	Platt, Chas. S., 31 Gold st., N. Y..... 48		Hotels.	
	Robertson & Leber, 13 Franklin st., Newark, N. J..... 48		Russell House, Chicago, Ill..... 47	
	Auctioneers.		Imported Clocks, Bronzes, Etc.	
	Comrie, A. J., 16 West 125th st., N. Y..... 36		Glaenzler, L. J., & Co., 80 Chambers st., N. Y. 33	
	French, J. H., Box 2775, N. Y..... 43		Jewelry Repairers.	
	Badges, Medals, etc.		Wiederhold, A., 20 Maiden Lane, N. Y..... 42	
	Stockwell, E. R., 1, John st., N. Y..... 14		Jewelry and Silverware Cases.	
	Black Onyx Jewelry.		American Morocco Case Co., 9 Bond st., N. Y. 27	
	Woglom, Gilbert T., 32 John st., N. Y..... 40		Jackson, S. C., 180 Broadway, N. Y..... 18	
	Books, Stationery, etc.		Wiggers & Froelick, 60 Nassau st., N. Y..... 46	
	Dickie, W. B., 67 William st., N. Y..... 14		Jobbers, Watches, Diamonds, etc.	
	Cut Glass.		Aikin, Lambert & Co., 23 Maiden Lane, N. Y. 14	
	Clark, T. B. & Co., 53 Park Place, N. Y..... 9		Beguelin, Tell A., 71 Nassau st., N. Y..... 40	
	Dorflinger, C. & Sons, 36 Murray st., N. Y..... 27		Bowman & Musser, Lancaster, Pa..... 21	
	Mt. Washington Glass Co., New Bedford, Mass. 47		Conover, D. S. & Co., Philadelphia, Pa..... 24c	
	Phoenix Glass Co., 729 Broadway, N. Y..... 14		Cross & Beguelin, 21 Maiden Lane, N. Y..... 11	
	Clock Manufacturers.		Friedlander, R. & L., 65 Nassau st., N. Y..... 40	
	Grady, T. H., & Co., 263 Fulton st., Brooklyn. 18		Koch & Dreyfus, 22 John st., N. Y..... 45	
	Diamond & Precious Stone Importers.		Myers, S. F. & Co., 48 Maiden Lane, N. Y..... 48	
	Breidenbach, R. A., 31 Maiden Lane, N. Y..... 18		Scott, J. T. & Co., 4 Maiden Lane, N. Y..... 26	
	Fera, Henry, 5 Maiden Lane, N. Y..... 44		Yates, John B., 147 Nassau st., N. Y..... 38	
	Gunzburger Bros., 35 Maiden Lane, N. Y..... 48		Lamps.	
	Hedges Wm. S. & Co., 170 Broadway, N. Y..... 39		Eakins, G. & Son, Philadelphia, Pa..... 29	
	Kahn, L. & M. & Co., 10 Maiden Lane, N. Y. 48		Musical Boxes.	
	Kipling, E. E., 2 John st., N. Y..... 48		Jacot & Son, 298 Broadway, New York..... 40	
	Kipling, R. A., 31 Union Square, N. Y..... 39		Optical Goods.	
	Lorsch, Albert & Co., 37 Maiden Lane, N. Y. 48		Geneva Optical Co., 23 Washington st., Chicago, Ill..... 36, 39, 40	
	Oppenheimer Bros., & Veith, 35 Maiden Lane, N. Y..... 35		Levy, Dreyfus & Co., 11 Maiden Lane, N. Y. 26	
	Randei, Baremore & Billings, 29 Maiden Lane, N. Y..... 13		U. S. Optical Co., 17 Union Square, N. Y. 36	
	Smith, Alfred H. & Co., 182 Broadway, N. Y. 24		Zineman, M. & Bro., Philadelphia, Pa..... 18, 47	
	Taylor & Bro., 860 Broadway, N. Y..... 14		Order Work.	
	Wheeler, Hayden W. & Co., 2 Maiden Lane, N. Y..... 35		Maxheimer & Beresford, 3 Maiden Lane, N. Y. 39	
	Diamond Cutters.		Pens, Pencil Cases, Etc.	
	Groenman, A. J. & Co., 80 Nassau st., N. Y. 13		Aikin, Lambert & Co., 23 Maiden Lane, N. Y. 14	
	Diamond Jewelry.		Smith, H. M. Co., 83 Nassau st., N. Y..... 31	
	Bynner, T. B., 177 Broadway, N. Y..... 47		Ring Makers.	
	Buschmeyer & Seng, Louisville, Ky..... 44		Bowden, J. B. & Co., 192 Broadway, N. Y. 10	
	Falkenau, Oppenheimer & Co., 40 Maiden Lane, N. Y..... 48		Bryant, M. B. & Co., 10 Maiden Lane, N. Y. 10	
	Nissen, Ludwig, & Co., 18 John st., N. Y..... 42		Haskell, H. C., 192 Broadway, N. Y..... 15	
	Peckham, Chas. H., 63 Nassau st., N. Y. 26		Hildreth Mfg. Co., 51 Maiden Lane, N. Y. 42	
	Pinover, A. & Co., 25 Ann st., N. Y. 0		Ostby & Barton, 80 Clifford st., Providence, R. I..... 38	
	Sexton Bros. & Ashburn, 41 Maiden Lane, N. Y..... 39		Odenheimer & Zimmern, 46 Maiden Lane, N. Y. 48	
	Stern Bros., 42 Maiden Lane, N. Y..... 39		Rolled Plate Chains.	
	Engravers and Designers.		Barrows, H. F. & Co., 1½ A, Maiden Lane, N. Y..... 18	
	Bartholomew & Peckham, 18 Spruce st., N. Y. 38		Kent & Stanley, 7 Eddy st., Providence, R. I. 3	
	Beecher & Clark, Louisville, Ky..... 29		Rolled Plate Jewelry.	
	Ryder & Dearb, 146 Westminster st., Provi- dence, R. I..... 38		Crossin & Tucker, 409 Pine st., Providence, R. I..... 46	
	Eye Glass Holders & Chains.		Foster & Bailey, 60 Richmond st., Providence. R. I..... 33	
	Merritt, S. F., Springfield, Mass..... 46		Ludwig, H. & Co., Providence, R. I. 31	
	Gold and Silver Platers.		Plainville Stock Co., Plainville, Mass. 40	
	Newman, Louis, Jr., 36 John st., N. Y..... 46		Seamless Wire.	
	Gold Jewelry.		Burdon Seamless Filled Wire Co., Providence, R. I..... 40	
	Bipart & Co., Newark, N. J..... 37		Settings & Galleries.	
	Carter, Sloan & Co., 15 Maiden Lane, N. Y. 44		Blancard & Co., 36 John st., N. Y..... 40	
	Cottle, S. Co., 860 Broadway, N. Y..... 40		Silk Guards.	
	Day & Clark, 10 Maiden Lane, N. Y. 9		Rosentall, Wm., 79 Nassau st., N. Y..... 33	
	Krementsz & Co., 182 Broadway N. Y..... 33		Silver Plated Ware.	
	Larter, Elcox & Co., 41 Maiden Lane, N. Y. 13		Pairpoint Mfg. Co., New Bedford, Mass. 5	
	Moore & Horton, 11 Maiden Lane, N. Y. 42		Rogers, Wm., Mfg. Co., Hartford, Conn. 36	
	Riley, J. A., & S. Can Co., 860 Broadway, N. Y. 15		Rogers & Hamilton Co. The, Waterbury, Conn. 48	
	Snow & Westcott, 4 Maiden Lane, N. Y. 21		Rogers & Bro., 16 Cortlandt st., N. Y. 44	
	Street, Geo. O. & Sons, 15 John st., N. Y. 44		Stem-Winding Attachments.	
	Gold Chains.		Abbott, Henry, 4 Maiden Lane, N. Y. 35	
	Rickert & Stuehle, Newark, N. J..... 14		Sterling Silver Novelties.	
			Alvin Mfg. Co., 860 Broadway N. Y. 29	
			La Pierre, F. H., 18 East 14th st., N. Y. 13	
			Lewis Bros., 41 Maiden Lane, N. Y. 29	
			Sterling Silverware.	
			Gorham Mfg. Co., 19 st. & Broadway, N. Y. 24	
			Towle Mfg. Co., Newburyport, Mass. 10d	
			Wallace, R. & Sons, Mfg. Co., 3 Park Place, N. Y. 6	
			Wood & Hughes, 16 John st., N. Y. 44	
			Souvenir Spoons.	
			Conover, D. F. & Co., Philadelphia, Pa. 24	
			Dole, H. L., Haverhill, Mass. 22	
			Durgin, W. B., Concord, N. H. 11	
			Gorham Mfg. Co., Union Square, N. Y. 7	
			Gooding Bros., Plymouth, Mass. 9	
			Homer, Geo. E. Boston, Mass. 18	
			Johnston, J. H., & Co., 17 Union Square, N. Y. 41	
			Lyon, W. H., Newburgh, N. Y. 23	
			Moore & Leding, Washington, D. C. 19	
			Norton, A. D., Gloversville, N. Y. 18	
			Newhall, W. F., Lynn, Mass. 11	
			Spear, H. T., & Son, Boston, Mass. 21	
			Sterling Silver Souvenir Co., Boston, Mass. 17	
			Whiting Mfg. Co., Union Square & 17th St., N. Y. 4	
			Thimbles.	
			Ketcham & McDougall, 198 Broadway, N. Y. 16	
			Tool Manufacturers and Dealers.	
			American Watch Tool Co., Waltham, Mass. 12	
			Bullock, O. W. & Co., Springfield, Mass. 40	
			Nordman Bros., San Francisco, Cal. 47	
			Nicholson File Co., Providence, R. I. 29	
			Watch Companies.	
			Columbus Watch Co., Columbus, O. 34	
			Illinois Watch Co., Springfield, Ill. 24b	
			Non-Magnetic Watch Co., 177 Broadway, N. Y. 14	
			Trenton Watch Co., Trenton, N. J. 42	
			Watch & Clock Dials.	
			Waltham Dial Co., Waltham, Mass. 14	
			Watch & Clock Oils	
			Ginnel, Henry & Co., 31 Maiden Lane, N. Y. 46	
			Nye, William F., New Bedford, Mass. 36	
			Watch Keys.	
			Clark, A. N., Plainville, Conn. 39	
			Kendrick & Davis, Lebanon, N. H. 42	
			Watch Case Manufacturers.	
			Crecent Watch Case Co., 5 Bond st., N. Y. 20	
			Dueber Watch Case Mfg. Co., Canton, O. 16	
			Essex Watch Case Co., Newark, N. J. 46	
			Muhr's Sons, H., 629 Chestnut st., Philadelphia, Pa. 48	
			Roy Watch Case Co., 17 Maiden Lane, N. Y. 48	
			Watch Case Repairers.	
			Feinier, G. F., 9 Bond st., N. Y. 45	
			Felix, N. J., 71 Nassau st., N. Y. 9	
			Watch Importers.	
			Didisheim, Hipp, 83 Nassau st., N. Y. 13	
			Hydes' Sons, John E., 22 Maiden Lane, N. Y. 44	
			Wittnauer, A., 30 Maiden Lane, N. Y. 43	
			Watch Materials, &c.	
			Cross & Beguelin, 21 Maiden Lane, N. Y. 11	
			Friedlander, R. & L., 65 Nassau st., N. Y. 40	
			Keller, L. H. & Co., 64 Nassau st., N. Y. 15	
			Watch Repairers.	
			Juzek, Thos. & Co., Elgin, Ill. 39	
			Simmonds, J. C., 18 John st., N. Y. 46	
			Watch Springs.	
			Hammel, Riglander & Co., 35 Maiden Lane, N. Y. 29	

Special Notices.

Rates 75c. per insertion for notices, not exceeding 3 lines; additional words 2 cents each. If answers are to be forwarded, postage stamps must be enclosed. Two insertions, 10 per cent. off; three insertions, 15 per cent. off; four insertions, 25 per cent. off. Payable strictly in advance.

Situations Wanted.

THE JEWELERS' CIRCULAR has a guaranteed circulation of over 10,000 copies weekly. It is, therefore, the best medium for reaching the trade. To demonstrate this to advertisers, notices in this column will be inserted free of charge during the month of April.

A FIRST-CLASS watchmaker wishes to make arrangement with a good house in New York or Boston, to work four to six hours a day. Address Expert, care of THE JEWELERS' CIRCULAR.

A LIVE young man of ability and experience desires position with responsible house to represent them on the road; jewelry or watches preferred; familiar with southern trade; A 1 references. Address, Salesman, care of JEWELERS' CIRCULAR.

A NICKEL PLATER desires a situation; thoroughly understands the business; can give best of reference if required. Address, Plater B, this office.

A PERMANENT situation wanted by a young married watchmaker and jeweler, with twelve years' experience at the bench; New England States preferred. Address, Honest, care of THE JEWELERS' CIRCULAR.

SITUATION wanted as clerk in retail, or traveler for wholesale jewelry house; nine years' experience in retail jewelry business; can give best references; New York, Philadelphia or Boston preferred. Address A. B. C., care of THE JEWELERS' CIRCULAR.

SITUATION wanted by a young man as credit clerk; understands position thoroughly, as well as all office work, bookkeeping, etc. Good reasons for wishing to make a change. Address, H., P. O. Box 3306, N. Y. City.

SITUATION WANTED with first-class watchmaker, as assistant, where I can be instructed in staffing, etc. Address, W. J. Greenawalt, Reading, Pa.

WANTED.—A situation for a good watchmaker that I can recommend. Address, W. F. A Woodcock, Winona, Minn.

WANTED.—By a single man of about 30, with nineteen years' experience in the trade, a position as first-class watchmaker and repairer. Is familiar with the use of the lathe. Address, John Scherer, care THE JEWELERS' CIRCULAR.

YOUNG MAN, twenty years of age, would like a situation with a jewelry or optical house; has had experience in both lines of business; satisfactory references. Address Johnson, care of THE JEWELERS' CIRCULAR.

Help Wanted

WANTED.—An experienced salesman in the silver plated ware trade (Hollow Ware); he is to make three or four trips during year, and to look up near-by trade; must be thoroughly acquainted with the jewelry and department store trade; good opening for the right man. Address A. S. P., care of THE JEWELERS' CIRCULAR.

WANTED.—Optician and engraver, optician and watchmaker, and engraver who can assist in selling and displaying goods in a large Southwestern city; as engraver, work must be good; only competent men need apply, stating age, salary and references; steady positions are assured the right men. Address, ompent, care of THE JEWELERS' CIRCULAR.

WATCHMAKER WANTED.—Young man preferred with \$1,000 or more to add to an already established jewelry business; loan and pawn business in a city of 25,000 inhabitants; no such business in the city; fair trade and run of work; no fooling; strictly legitimate party. Address, G. F., 74½ Remsen St., Cohoes, N. Y.

To Let.

TO LET.—One office on first floor, one on second floor, and one third floor, of Knapp Building 41 and 43 Maiden Lane, N. Y.

For Sale.

A FINE ship chronometer for sale cheap. Address: A. C. Taylor, Cedar Rapids, Iowa.

FOR SALE.—On account dissolution of partnership, three iron safes; one fine "Herring Patent Champion"; also fixtures, shop tools, etc. Apply to Moore & Horton, 11 Maiden Lane, New York.

FOR SALE. Rare good business opportunity for any watchmaker with \$1,800 cash; good paying jewelry business, in a rapidly-growing town in Western New York; rent low; good trade and plenty of repairing. Present owner not able to look after it. Address, U. S. C., care of THE JEWELERS' CIRCULAR.

FOR SALE.—One of the best jewelry stores in New England city of 20,000; stock \$4,000. A big chance for man with cash. Address, C. D. N., care of THE JEWELERS' CIRCULAR.

\$2,500 SECURES an opportunity of a lifetime, for a jewelry business in the great and growing State of Washington. Address, R., care of THE JEWELERS' CIRCULAR.

Business Opportunities.

\$2,000 IN CASH and two thousand in notes, will buy old-established and paying jewelry business near New York. Address, Wm. McAdie, with Rogers & Bro., 16 Cortlandt St., N. Y.

Miscellaneous.

TO MANUFACTURERS of Clock Movements.—Wanted, a good eight-day movement, to fit onyx and marble cases; send particulars and price for quantities to Case Manufacturer, care of THE JEWELERS' CIRCULAR.

W. F. A. WOODCOCK'S SCHOOL FOR WATCHMAKERS, Winona, Minn., offers unrivaled facilities for acquiring a thorough practical knowledge of every branch of the business. Terms very reasonable.

WORK FOR THE TRADE.—All kinds of watch and jewelry repairing. Skillful workmen, prompt attention and satisfaction guaranteed. Address, A. W. Johanson, 176 & 178 Market st., Chicago, Ill.

BEECHER & CLARK,



Engravers,

Designs and Estimates Furnished on Application.

352 JEFFERSON STREET,

Guthrie Block, LOUISVILLE, KY.

ALVIN MFG. CO.,

SILVERSMITHS.

860 Broadway, New York.

206 Kearney St., San Francisco.

Factory, NEWARK, N. J.

NICHOLSON FILE COMPANY,
Offices at Providence, R. I.

FILES—Extra  Fine—RASPS

Works at Providence, R. I. —FOR— Works at Pawtucket, R. I.
JEWELERS, WATCHMAKERS, TOOLMAKERS, Etc.

WATCHMAKING SCHOOL.

Have your Young Men become No. 1 Artisans by sending them to

R. Jaegerman's Watchmaking School.

For particulars, write to

R. JAEGERMAN, Manager,

No. 622 Locust St., ST. LOUIS, MO.

MAINSPRINGS.



For Sale by all Jobbers.

NEW GOODS—STERLING SILVER.

Spring Novelties.

Lewis Brothers,

41 Maiden Lane, New York.



THE PRINCESS LAMP.

The handsomest decorative Lamp ever produced. Made in largest variety, and richest designs by

GEORGE EAKINS & SON,

616 Chestnut St., Phila., Pa.

Made expressly for fine Jewelry Trade.

SEND FOR DESCRIPTIVE PAMPHLET AND PRICES.

Judge Beach's Decision in the Stern & Stern Failure.

Judge Beach, of the New York Supreme Court, decided that the judgment creditors of the late firm of Stern & Stern had prior claims over the attaching creditors for the \$15,000 which are held by the sheriff.

The suits which the Judge decided are of the failure of Stern & Stern, in November, 1889. The attachment creditors, Columbus Watch Co., W. & S. Blackinton, D. H. Wickham & Co., H. F. Barrows & Co., and Engelfried, Braun & Weidmann, sued to have the judgments entered in favor the following firm, set aside: Hodenpyl & Sons, Fidelity Watch Case Co., Ludeke & Co., L. & M. Kahn & Co., Albert Lorsch & Co., Samuel Eichberg, Keller & Untermeyer, Oppenheimer Bros. & Veith, Jeannette David and Yetta Sondheim.

Stern & Stern were formerly in business at 13 Maiden Lane, New York. On Nov. 29, 1889, judgments were entered against the firm in favor of the creditors above mentioned. Three of the judgments were for money loaned, and the remaining for merchandise sold and delivered. The stock of the firm which was found in the store was sold at Sheriff's auction, and suit was brought by the above attaching creditors, alleging that the judgments were the result of a scheme to defraud the creditors. They asked for an injunction restraining the Sheriff from paying any of the money realized from the sale. A preliminary injunction was granted by Justice Patterson, to hold until the present suits were decided.

T. G. Frothingham and several other Providence creditors also brought similar suits against the judgment creditors, but their actions differed from the other plaintiffs', inasmuch as they were neither attaching creditors nor lienors on any assets which have been levied upon by the defendants. They are simply general creditors, but Judge Beach's decision holds in their case the same as in the rest.

Hays & Greenbaum are the legal representatives for the defendants in these suits and Franklin Bien for the plaintiffs. Mr. Bien when seen by a CIRCULAR reporter said: that while the case has been decided against him mainly on a question of law he has the same confidence in his position as he had before the decision and will bring on the appeals as speedily as possible and no time will be lost." Judge Beach has granted thirty days to make a case on appeal.

Chicago.

Frank Burnett, who has sold out his business at Camp Point, this State, will locate in this city.

C. J. Dodgshun assumed control of the Western branch of the Waterbury Clock Co., on April 1.

Sebastian Andersen, of Juergens & Andersen, has returned from a six weeks' sojourn at Hot Springs, Ark.

The next regular meeting of the Chicago Jewelers' Association will be held on the afternoon of April 8. By reason of the munic-

ipal elections on the 7th, this meeting is advanced one day.

R. B. Steele, representing Larter, Elcox & Co., 41 Maiden Lane, New York, is calling on the trade in this city and is doing a good business in the patent spring-back studs, which his firm make.

The total liabilities of Ehrlich Bros. amount to \$24,306.50. The firm's offer of forty cents on the dollar is being accepted. Of the total indebtedness the following items are included, being due: Salaries, \$271.33; bills payable, \$1,741.04, (Crossin & Tucker, Providence, R. I., \$1,192.42; Albert Eddy & Co., Providence, R. I., \$298.62; G. Rheinauer, New York, \$250.00) and checks returned (no particulars given), \$116.51.

To Set Aside E. R. Kant's Transfer.

CLEVELAND, O., April 5.—Two or three days previous to the assignment of E. R. Kant, his father died, leaving a will in which his wife is made heir for life. After her death the elder Mr. Kant's property is to go to the children, three daughters and a son, E. R. Kant. After his failure Mr. Kant gave a quit claim deed to his sisters for his interest in the real estate, for \$400.

To-day the firm of Fink, Bodenheimer & Co., New York, sued Kant to recover money due on several small notes. In their petition the plaintiffs claim that the transfer of Mr. Kant's interest in the property to his sisters was fraudulent, and that it was done for the purpose of defrauding his creditors. They ask that the transfer be set aside.

A GREAT CONVENIENCE FOR

⌘ Clock Dealers and Repairers. ⌘

We have now a complete stock of Wheels, Pinions, Hands, Dials and all loose pieces for French and English movements. Also single movements with or without dials.

Our stock of imported clocks comprises Chiming and Hall Clocks, Sèvres and Faience, Vernis Martin, Gilt Bronze, Crystal with Mercurial Pendulum, Carriage Clocks in endless variety of styles and combinations, Marble and Onyx Clocks of the best selling designs, Coaching and Desk Watches, Regulators, etc.

NEW GOODS ARRIVING EVERY WEEK.

Apply for our Catalogue, or inspect our stock to compare our prices.

CHARLES JACQUES & CO.,

2 MAIDEN LANE, NEW YORK.

Cincinnati.

Louis Rauch is out on the road.

A number of Cincinnati jewelers are experimenting with aluminum.

S. Steinau, of H. Ludwig & Co., Providence, R. I., is here on a visit to his home.

Joseph Hellebush is laid up at Owensboro, Ky., and Charles Goepfert has gone to his relief.

John Schweikert is out on the road again, while Eugene Schweikert has got in. Mr. Thompson will go out this week.

Albert Bros. have put in a second safe, next to the largest size made. Louis Albert, weather permitting, will make his opening trip next week.

Herman Keck has the honor of sitting in an office chair made of the wood that formerly did service in a big arm chair in the Court of Louis XIV.

Oskamp, Nolting & Co. are putting on the market a Cincinnati souvenir spoon in which the celebrated Tyler-Davidson Fountain is etched in the bowl, while the handle is elaborated in fancy design with the name of Cincinnati.

D. J. Mendenhall, the Indiana traveler of Oskamp, Nolting & Co., has received the honorable distinction of State Commissioner for Indiana to the World's Fair. The appointment was made by the Governor. Mr. Mendenhall has been prominently before the public as a successful politician, serving in the Legislature several terms.

The subject of early closing has again come up. St. Louis has established a precedent by beginning on April 1st. Cincinnati is enterprising enough, but there is a lack of harmony among her jewelers that has been a serious drawback to mutual benefit. It was thought that the Jobbers' Association would do much toward abolishing the ill-feeling that exists.

If the meetings were more frequent much could be accomplished from a social standpoint, and the evils of rivalry, if not entirely eradicated, could be in a great measure abated. Last year a compact was entered into by the jewelers to close at five in the evenings, and at 1 P. M. on Saturdays. The greater part held to their agreement, but it is claimed that some did business behind closed doors, and some did not close at the specified time at all.

The suit brought by J. A. McDonald against Herman Lange, 181 Vine St., for \$708.46 due by a promissory note is in dispute over a Kansas City land transaction. Mr. Lange claims that the signature on the note was obtained fraudulently, and feels confident that he will win the case. Mr. Lange's credit is considered very high by the trade, and he is not known to have been sued in twenty years.

A. Steinau & Co. repudiate the claim of L. D. Moody, an insurance agent, who has acted as a sort of a diamond broker among

his fraternity, in the statement that he was sold an emerald doublet for a genuine stone. Moody bought the ring for \$75. It was a cluster, the emerald doublet being surrounded by diamonds, which Mr. Steinau claims to have cost \$65. Moody left town and soon wrote back for the weight of the stones. S. Steinau answered the letter. Some days after Moody came in the store and demanded his money back, saying he had been swindled. He had been to Fox Bros. & Co., who told him the stone was an imitation. Mr. Steinau refused to refund, and Moody hunted up a lawyer who sent a note to Steinau to pay the money or stand a suit. At first Mr. Steinau stubbornly refused to do so, but upon the advise of friends he paid the money back, and also \$20 fee to the lawyer. He says he did so to keep out of unpleasant notoriety.

Indianapolis.

A. H. Heath, Veedersburgh, this State, gave the wholesale dealers a call last week.

J. M. Washburne, Celina, O., has purchased a stock of goods from Nichols, Pie & Co., wholesalers in this city, and has opened a branch store at Spencerville, O.

Sheriff Thomas F. Phillips arrived here last Sunday from Dubuque, Ia., to receive Charles Jones and Robert, alias Bud Grayson, for robbing Barton's jewelry store in that city, a month or so since, of two watches, valued at \$250.

J. E. Meyer, employed as a clerk by the Pittsburgh & Western Railroad Company at Pittsburgh, by representing himself as a son of Stoughton J. Fletcher, the banker, last week secured diamonds, watches, clothing, etc., here aggregating several hundred dollars in value. He was arrested as he was about to take a train for St. Louis.

Julius Walk, of Bingham & Walk, has purchased the sole right from W. B. Burford, who owns the copyright purchased of the State Commission in charge of the monument, to use the design of the Soldiers' and Sailors' monument, for silverware decoration. The monument is now in process of erection, and will be 265 feet high, surmounted by a crowning piece by Brewster, which is one of the finest work of modern sculpture.

Odd Notes.

J. C. Dueber, of the Dueber Watch Case Mfg. Co., is about to locate permanently with his family in Canton, O.

A co-partnership has been formed by C. C. Brown, D. A. Hixson and G. McC. Hixson to carry on the jewelry business at the old stand of Hixson & Syke, Lockport, N. Y.

The thieves who have been breaking jewelers' windows in Brooklyn, N. Y., for the past month, without detection by the police were again successful early Sunday morning. The plate glass window of the store of Louis Alexander, optician, 192 Fulton St., was smashed and twenty pairs of gold spectacles, seven gold eye glass chains, three pairs of marine glasses and three dozen pairs of gold eyeglasses, valued in all at \$262 were stolen. As in all the other robberies there is no clue to the thieves.

Sturgeon & Warren, the new diamond house at Detroit, Mich., opened their salesrooms last Monday, with a fine line of diamonds and other precious stones and novelties in jewelry. The salesrooms, in point of elegance, surpass perhaps anything in the city. The ceilings are copied after the famous blue room in the White House at Washington, and the walls are decorated à la Louis XIV. There is a private diamond parlor, and adjoining a "dark room," where the purchasers may examine the effect by electric light. This is an innovation in salesrooms only found elsewhere in but few establishments. The members of the new house are well and favorably known, Mr. Sturgeon having been connected with F. G. Smith, Sons & Co. for thirteen years, and Mr. Warren with Wright, Kay & Co. for several years.

H. M. SMITH & CO.,
MANUFACTURERS OF
Gold Pens and Pencil Cases,

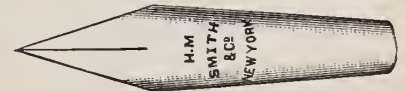

JOBBERS IN AMERICAN WATCHES.
PLATED CHAINS.
Agents for Paul E. Wirt's Fountain Pen.
83 Nassau Street, New York City.

H. LUDWIG & CO.
FACTURERS OF
NOVELTIES IN JEWELRY
LARGEST MFGOR. ESTABL. IN THE U.S.
POPULAR PRICE JEWELRY IN U.S.

NEW YORK OFFICE,
PRESSCOTT BUILDING,
ROOM 40 SAMPLES ONLY

WORKS, BLACKSTONE & GAY STS.
TAKE PRAIRE AVE CAR
Providence, R.I.

TRADE GOSSIP

The advertisement of T. H. Grady & Co.'s electric alarm clock and call bell, published in another column, should be read by the jewelry and clock trade. It is new, useful and novel, and has a large field of adaptability among business men as well as for home use.

The "Bryant" initial ring has advantages that place it in the very front of rings of its class. It is easily interchangeable, simple in construction, and perfectly secure when the initial is fastened in place. The manufacturers state with a pardonable pride that they have never had a single call to replace a lost initial, and that, so far as they can ascertain, no initial has ever been lost from a "Byrant" initial ring.

M. Zineman & Bro., "The Busy Opticians," 130 S. Ninth St., Philadelphia, Pa., are doing a very extensive business in artificial eyes, which they recently added to their list of specialties. They have just taken the largest order ever placed for this class of goods in this country. Their facilities for supplying the trade are second to none, as they are the sole American agents for Muelers' eyes, made at Thuringen, Bavaria.

Charles Jacques & Co., importers of fine clocks, 2 Maiden Lane, New York, whose advertisement appears in another portion of this issue, are extending their trade in every direction. M. F. Harris, one of the new members of the firm, has just returned from Europe, where he has been superintending the construction of many new designs for his house. He is about to visit all the large cities of the country.

One of the prettiest decorative objects of recent production is the Princess Lamp, manufactured by George Eakins & Son, 616 Chesnut St., Philadelphia, Pa. It is small and dainty and can be had to conform with any decoration, the fonts being made in various colors. The lamp will fit into any candlestick or candlebra and its price is very reasonable. Write to Eakins & Son if you are as interested in lamps as most jewelers are.

Nothing adds to the attractiveness of a jewelry store more than handsome cases. A poor stock will sometimes appear other than it is when surrounded by fancy woodwork and beautiful trays. These are truths, and no one can bear them out better than S. C. Jackson, 180 Broadway, New York, who for years has manufactured fine jewelry and silverware cases and show case trays for jewelers all over the country. To those about to renovate their stores he will send samples on application.

Where to send a watch case to be repaired in a manner that will prove satisfactory to the customer, is a question that often occurs

to the trade. For the information of those interested it may be stated that G. F. Feinier, 9 Bond St., New York, has a large factory, with extensive facilities for repairing and manufacturing watch cases of every description. He employs the latest improved appliances and has a force of from fifteen to twenty-five artisans, who are all experts in their various branches. Jewelers should bear this in mind when about to place a watch repairing job.

The Dueber Watch Case Mfg. Co. are producing some beautiful cases in vermicelli and other ornamental styles. Mr. Dueber, whose inventive genius is too well known to need any commendation, has in contemplation a number of new designs which will be shown to the trade in a short time. The Dueber Company are now transacting all their business from the general office at Canton, O., and the change has proven of great benefit to the trade, as all orders are now filled with promptness and correspondence attended to without delay. The company report that the factories are busier than ever before at this season of the year.

The Spencer Optical Mfg. Co., 15 Maiden Lane, New York, have recently received large importations of fine telescopes, field and spy glasses. The firm is now showing field glasses with the adjustable centers, which have proven such a success when applied to opera glasses. Some idea of the Spencer Optical Co.'s business can be gathered from the fact that they are now sending out daily 6,000 pairs of spectacles and eye glasses, which make an annual total of 1,800,000 pairs. The Victory opera glass holder, which the firm are sending to all parts of the world, has been in great demand since its being made of aluminum, with an exterior of mother of pearl, and possessing the improved grip, first revealed to the public its superiority.

No industry has made such rapid progress during the past few years as that of watch case making, and it does not require a very heavy strain on the memories of the old-time jewelers to remember the time when cases were entirely hand made, and the stamping implements of to-day were but bright visions of the future. In this issue of THE CIRCULAR there is illustrated the new factory of the Crescent Watch Case Co. in Newark, N. J., which when finished will be one of the finest of its kind in the world. It has a frontage of 218 feet, and contains three floors, each of which in a few weeks will be a forest of whirling helting and revolving wheels, illustrating in a forcible manner the advancement of case manufacturing during the last decade. The total floor area of the new factory will be 60,000 square feet. There will be water reservoirs capable of holding 50,000 gallons each, and an engine of 200 horse power. The company have purchased land in the vicinity of the factory, on which dwelling-houses for the operatives will be built. The employes will be allowed to purchase the houses, and pay for them on easy terms, so that, after a few years, most

of them will own their homes. The present officers of the company are W. H. Fitzgerald, President; A. M. Crommelin, Treasurer; A. Beucke, Superintendent. It was only last April that the concern purchased the entire silver watch case plant of the American Waltham Watch Co. The Crescent Watch Case Co. were started in Brooklyn, N. Y., in 1885, with a factory confined to two small lofts; they have gained their present pinnacle of success, through unceasing industry and a perfect appreciation of the requirements of the retail trade.

One of the solid industries of Springfield, Ill., is the watch company which take their name from the State of Illinois. The writer on his way from St. Louis to Chicago stopped off last Friday to see the third largest watch factory, in point of output, in this country. The factory is situated in the northern part of the city and as approached by a stranger for the first time impresses him in two ways: 1st., by the simple but imposing appearance of the buildings in which the watch company find their home; 2d., by the charming rural scene that holds the eye captive by taking in fifteen acres of prairie grass plat, in the midst of which stands the Illinois Watch Company's works. The manufacture of watches by this company dates back nearly twenty years. Of its earlier history it will suffice to say that it had vicissitudes like all young ventures. These were all survived. About thirteen years ago the present management took charge of the Illinois Watch Co., and from that time dates their success. At first it was slight, but perceptible. Year by year it forged ahead until now we find them with seven hundred people on its pay roll, and putting on the market three hundred and eighty finished movements each day. The ponderous engine turns with a capacity of running this up to six hundred. In going through the Illinois works the writer noticed very little difference between them and the other large factories he had visited. There was the same intricate machinery, the same manipulation and detail that holds the non-mechanic spell-bound, no matter how often he goes through. One thing that impressed the writer on this occasion, especially in the finishing and adjusting rooms as well as in other portions of the works where inspection was going on, was the extra care and precaution that was exercised. This company are turning out superior movements in 18, 16, 14, 8, 6 and 4 sizes, in all the different grades. The management are no believers in high-sounding self-adulation, but rather in quiet, easy methods that are just as effective, and that makes the retail jeweler, and the man that luckily carries one of the watches herald the true merits of the watch. The writer took his reluctant departure, after two hours of profitable inspection, feeling that not only have the management of the Illinois Watch Co. just cause for congratulation on their splendid showing, but also the Commonwealth from which they take their name every reason for feeling just pride.

A. & J. Plaut, Cincinnati, O., have circulated among the trade circulars announcing that they have a lot of Dueber cases that they will sell very low.

The gold filled cases of the Essex Watch Case Co., 6 Maiden Lane, New York, are meeting with general satisfaction, and the factory at Newark, N. J., is kept continually busy.

The F. F. Ide Watch Tool and Mfg. Co., Peoria, Ill., have their new plant now in full operation. Watch work is one of the specialties of the company, who have a force of skilled operators for the purpose.

The increasing business of the Julius King Optical Co. has rendered necessary the leasing of that part of the store at 4 Maiden Lane, New York, now occupied by Henry Abbott. The addition will be fitted up as a private office for Leo Wormser.

Hayden W. Wheeler & Co., 2 Maiden Lane, New York, have their pocket price-list of American movements and cases ready for distribution. It has been carefully prepared in a condensed form so that it can be carried in the vest pocket. Copies of this list can be obtained by sending business card.

Albert Bros., Cincinnati, O., have issued very neat circulars to the trade. One important fact they mention, and that is, they have an entirely new stock to offer the trade. Louis Albert's intimate association with the trade has made him a close observer, and the goods he has bought have been selected with great care.

A. G. Schwab & Bro., Cincinnati, O., report a moving trade. From the travelers' cases at this house during the week one would infer that a host of Eastern men were here. They come in in numbers and stay only long enough to get a hint of the state of trade and go out on the next train. Those on the home stretch say that Chicago is no better.

Oskamp, Nolting & Co., Cincinnati, O., say that they are selling more fruit novelties than anything else in the jewelry line. By the way, every jeweler wants to see that new supplementary catalogue that this firm is getting out. There is to be offered a prize for a correct guess on something. Be sure and get a copy and send in your guess.

A profitable source of income for the retail jeweler is derived from the sale of bronze ornaments and statuettes. The Muller Bronze Co., Underhill and St. Marks Aves., Brooklyn, N. Y., are extensive manufacturers of this line of goods, and take great pride in the various designs shown by them.

As May 1st approaches, and hundreds of jewelers all over the country are preparing to move into new quarters, it should be remembered that B. & W. B. Smith, 220 W. 29th St., New York, have fitted entirely some of the principal jewelry stores throughout the country, including such representative establishments as the Gorham Mfg. Co., Tiffany & Co., Simpson, Hall, Miller & Co., and a host of others.

KREMENTZ & Co.,

182 & 184 Broadway, NEW YORK,

MANUFACTURERS OF

GOLD JEWELRY,

14-K. BEAD NECKLACES,

— AND —

KREMENTZ ONE-PIECE COLLAR BUTTONS.

Our line, composed of



*Chain Mountings, Chains, Neck Chains,
Crosses, Bead Necks, Bracelets, Bangles,
Earrings, Glove Buttoners, Garters,
Locketts and Charms, "Mount Hope" Buttons,
Initial Scarf Pins, Bar Pins, Cuff Pins, Jersey Pins,*

is of high grade rolled plate, and as a guarantee that they will wear well we stamp them **F. & B.**

Our sleeve button is the "Mount Hope" and is the best in the world.

W. ROSENTALL, Manufacturer of **Silk Vest Chains.**
79 NASSAU ST., N. Y.

with **GOLD & SILVER PLATED & OXIDIZED SLIDES.**

Send for Selection Package.

LEON J. GLAENZER & CO.,

80 CHAMBERS STREET

35 Boulevard de Strasburg,
PARIS.

NEW YORK.

OUR SPECIALTIES:

Clocks, Porcelains, Faience, Bronzes

We have now on exhibition and are constantly receiving large shipments of the latest novelties in **Onyx and Marble Clocks**, with Gilt and Enamelled Trimmings, **Regulators, Traveling Clocks, Porcelain and Gilt Mounted Clock Sets, Vases, Candelabras, etc.**, which we are offering at Lowest Prices.

Our stock also comprises a large assortment of **Porcelains, Faience, Bronzes, Gilt and Silver Photo Frames, Jewel Boxes, Bonbonnières, Mirrors** etc., suitable for the jewelry trade.

SPECIAL INDUCEMENTS ON IMPORT ORDERS.

New Calendar Clock.

A GERMAN watchmaker, H. Sievert, favorably known to many of the older readers of the CIRCULAR, through the trans-

perfect regularity, and is very cheap of construction. The accompanying illustrations show the acting parts of the new date work, as located upon the front plate of a spring striking regulator, fig. 1 showing the motion work, while fig. 2 specially represents on an enlarged scale, the lever carrying the month snail.

The rotation of the date wheel *e*, placed with its pipe easily revoluble upon the hour pipe, is in this invention effected in a manner entirely new, and different, to wit, from the barrel of the striking work. Between the two plates lies in bearing the arbor *a*, upon which is a small wheel dephing into the barrel wheel of the striking work, with a proper number of teeth so that—and consequently also the arbor *a*—it makes one revolution in every twenty-four hours. Upon the pivot of the arbor *a*, projecting beyond the plate *P* is a round disc *b* with segment-shaped notch *c* and a pin *d*, which gears into the tothing of the date wheel *e*.

The rotation of the disc *b*, therefore; is no regularly progressive one, but is interrupted periodically, occurring only when the clock strikes; in the meantime, however, the disc *b* remains inactive. Now, this is placed in such a manner upon the arbor *a*, that just

during the striking of twelve, at midnight, a suitable rotation of the disc *b* takes place, by which the pin *d* advances the date wheel *e* by one tooth. The unlocking of the latter, therefore, takes place always punctually at midnight. The pawl *f* serves for the purpose of retaining the date wheel *e* in its temporary position. A lifting of the pawl *f* can occur only when the notch *c* permits it, which is the case only at 12 o'clock, midnight; during the other time, the circumference of the disc *b* presses so closely to the pawl *f*, that the latter cannot be raised out of the tothing of the date wheel.

The date wheel *e* is furnished with teeth for only about one-half of its circumference, having at least thirty-three teeth; it is on its back furnished with a weight *r*, which gives it a preponderance to the left side, so that it constantly endeavors to turn in the direction of the arrow. In fig. 1 the date wheel is in the position it assumes on the last day of the month, on which day the pin *g* in its groove strikes upon the month snail *k*; in this position the weight *r* is situated near the centre line of the wheel, although always still a little to the left, and when the pawl *f* is now lifted out of the tothing of the date wheel *e*, the later turns to the left, until the weight *r* butts against the minute-wheel bridge *Z*, whereby the date hand upon the pipe of the wheel is brought back to 1.

Under the cannon pinion *n*, fig. 1, is located the plate, a short pin *m*, around which revolves the long double lever *l*¹, shown in

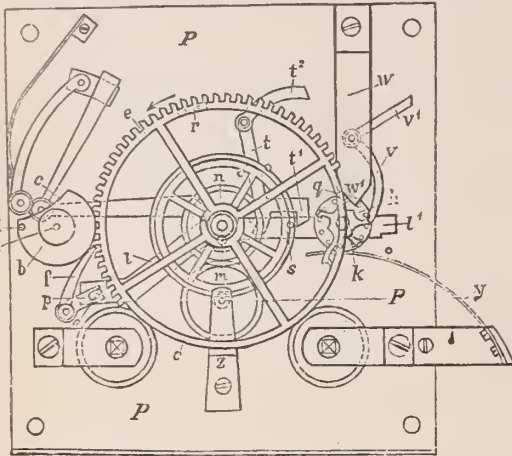

FIG. 1.

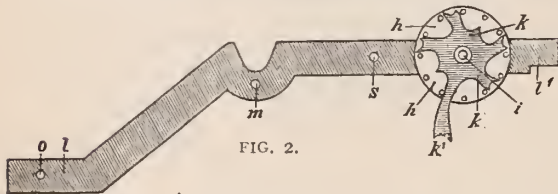

FIG. 2.

lated articles on watchmaking, published in its columns has constructed a clock with automatic regulating of date at the end of every month, which it is claimed works with

COLUMBUS WATCH CO.,



No. 97. Open Face.

Discontinues Movements

Nos. 27 AND 97.



No. 27. Hunting.

THESE are full Jeweled with extra large Center Jewel. Finely adjusted and just the thing for railway service. There are only a few of these movements on hand, and as they will be sold at a price that will move them QUICKLY, ask your jobber for them in time.

COLUMBUS WATCH CO.,

COLUMBUS, OHIO.

detail in fig 2. It has at its left end a pin *a*, while its right end bears the month wheel *a*, which is furnished with 12 pins, in the form of a lantern pinion; the month snail *k* is fastened immovably upon it. The parts *k k*, therefore, are together revolvable around the pin *i* fastened in the lever arm *l*. The double lever *l*¹ represents a kind of pivoted detent, which is kept in its position of repose by the spring *y*, fig. 1, applying to the month wheel *h*.

Between the plate *P* and the bridge *w*, revolvable by pivots, is the two-armed click *v*, which by the weight of the projecting arm *v*¹ always lays itself with its point between the pins of the month wheel *h*. The latter is retained in its position by the bridge-end *w*, ending in a point *w*¹. Firmly connected with the pawl *f* is a fork *p*, into which seizes the already mentioned pin *o* at the lever-arm *l*, so that, therefore, the month snail *k* and the pawl *f* are by the lever *l*¹ set into reciprocating action.

In the arrangement under debate, the date hand describes from the first day to the last of the month almost a semi-circle upon the dial, say, about from IX to III and the date figures are to be marked upon the dial correspondingly. A glance upon the month snail *k*, fig. 2, will tell the watchmaker at once that the notches in the snail serve for the months with 31 days, while the raised places are for those with 30 days, and the very high snail *k*¹ is for the 28 days of February. The several steps of the snail stand always in such a position that the pin *q*, fig. 2, in the date wheel, strike each upon the center of a step (which is slightly hollowed out, corresponding to the pin for the security), which takes place on the last day of every month.

When, now, in the next succeeding night, at the stroke of 12, the date wheel *e* is by the disc *b* set into rotation, then the pin *q*, striking upon the month snail, presses the arm *l*¹, of the double lever *l*¹, downward, whereby the click *v* interposes itself between the next two pins of the month wheel. At the same time, however, also the other arm *l*, of the double lever rises and lifts, by means of the pin *o*, the pawl *f* out of the tothing of the date wheel, which is now jerked back to the left, in the direction of the arrow, by the weight *r*, and thereby returns to its initial position.

Since the date wheel *e* necessarily requires a certain time for returning, provision has been made so that the pawl *f* remains lifted sufficiently long. For this purpose, a pin is screwed in the plate *P*, above the double lever *l*¹, upon which the easily revolving two-armed catch *t* is fastened. It has a preponderance upon the right side through the arm *l*², so that the projection *t*¹, always applies itself from the right against the pin *q*, in the lever arm *l*¹, so long as this remains in its position of repose. But when the arm *l*¹ is by the pin *q*, forced downward, the projection *t*¹ lays itself before the pin *s*, and retains the lever *l*¹ in this position, in which the pawl *f* is unlocked. The date wheel, therefore, has sufficient time to freely return into its initial position.

OPPENHEIMER BROS. & VEITH, Diamonds, Watches and Jewelry,

2 Tulp Straat,

AMSTERDAM.

35 Maiden Lane,

NEW YORK.

We beg to inform the trade that we are still in a position to fill orders for

✂ DUEBER HAMPDEN WATCHES ✂

Of all grades, from stock purchased previous to the closing of the factories at Canton.

HAYDEN W. WHEELER & CO.,

2 MAIDEN LANE, NEW YORK,

Have an unusually large and varied stock of

FANCY STONE RINGS,

CONSISTING OF

MOONSTONE, GARNET, TOPAZ, AMETHYST, PERIDOT,
PEARL, DOUBLET, SARDONYX,

And the various combinations of these Stones.

DIAMONDS, ✦ WATCHES, ✦ JEWELRY.

WANTED, AN ADVERTISEMENT.

I will pay Fifty Dollars in cash to the Retail Jeweler who shall prepare the best worded and most effectively displayed advertisement of *Abbott's Patent Stem-Winding Attachment*, suitable for use in Magazines and Newspapers that reach the general public.

The advertisement to occupy a space of not more than two inches high by five inches wide.

The contest will close May 1st, 1891, and the prize will be awarded within ten days from that date.

I WILL PAY
FIFTY
DOLLARS
IN CASH

The following gentlemen will act as judges:

Mr. L. J. MULFORD,
Of The Jewelers' Circular.

Mr. ALBERT ULMANN,
Of The Jewelers' Weekly.

Mr. JOHN L. SHEPHERD,
Of The Keystone.

Circulars and descriptive matter supplied on application.

HENRY ABBOTT,

After May 1st, 14 Maiden Lane.

4 Maiden Lane, N.Y.

ARE YOU DISSOLVING PARTNERSHIP
 ARE YOU HAVING DULL TRADE
 ARE YOU ABOUT TO RETIRE
 ARE YOU OVERSTOCKED
 ARE YOU REMOVING

IF YOU ARE, COMMUNICATE WITH

A. J. COMRIE,
 AUCTIONEER,

Specialty of Jewelers' Sales. 16 West 125th St., New York.



Geneva Optical Co.,
 MANUFACTURERS OF
 Spectacles, Eye
 Glasses, Lenses
 and Cases.
 23 WASHINGTON ST.,
 CHICAGO.

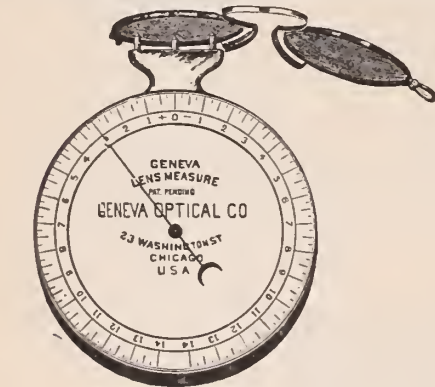

The Highest Grade
 — OF —
Electro Silver
Plated Ware

Is Stamped with the

ROGERS TRADE-MARKS.
 MANUFACTURED BY
The Wm. Rogers Manufacturing Co.,
 P. O. DRAWER 30,
 HARTFORD, - CONN.

UNITED · STATES · OPTICAL · CO
 15 Grand River Ave., Detroit, Mich.
 MANUFACTURERS AND JOBBERS OF
SPECTACLES and EYE GLASSES.

Special Attention given to Prescription Work, and Repairing by Skilled Workmen.

Our facilities for the manufacture of SPECTACLE and EYE GLASS CASES are such that we can quote lowest prices.

43 WILL FURNISH SAMPLES ON APPLICATION.

After about fifteen minutes the same unlocking pin in the quarter cason *z*, which had unlocked the stroke of twelve, arrived at the lower inward curved end of the rack hook *t*, and lifts this out so far that the projection *t*¹ liberates the pin *s*, after which the double lever *l*¹ is brought back by the spring *y* into its position of rest. During the time that the arm *l* rises, the point *w*¹ of the bridge *w* applies itself between the next two pins of the month wheel *h*, and conducts it one-third of a turn farther, so that then the next step of the month snail is placed in.

The date work under review can be altered into a complete calendar, by placing the month snail at a free place, and making it with a pipe prolonged in front. For indicating the week days it requires only a 7-toothed star to be brought into depth with the pin *d* of the disc *b*, which then advances one tooth every day, and which carries the hand for the week days. If a bi-sextile year is also to be introduced, it is only necessary to quadruple the month wheel and the snail. The month wheel must then have 48 pins, in place of 12, and the snail 20 raised pins, instead of 5. The fourth February snail is in this case made shorter by one tooth space of the date wheel.

On this principle, it is possible to alter the calendar work for various purposes.

Practical Electroplating.

THE following solution for gilding to be used with common battery, is sufficient for 4 gallon jar.

- Chloride of gold..... 4 oz.
- Cyanide of Potassium... 12 oz.
- Concentrated Ammonia..

Dissolve the chloride in *pure* boiling water, then by the use of a very small quantity of concentrated ammonia, precipitate the gold from the solution. Let the matter stand until settled; pour off the water; repeat operation two or three times, taking care not to wash out the gold. Now dissolve cyanide in hot water; this must be done in a vessel which is to hold the solution; pour in the gold and boil.

NICKEL SOLUTION.

To one gallon of water add from one to two pounds of nickel salts or crystals; boil and stir until cold.

SILVER SOLUTION.

- Chloride of Silver..... 10 oz.
- Carbonate of Soda..... 12 ozs.
- Cyanide of Potassium, enough to take up silver; make same as for gold plating.

BRASS SOLUTION.

- Sulphate of Copper.. 3 lbs. 6 oz.
- Sulphate of Zinc... 3 " 6 "
- Carbonate of Soda.. 10 "
- Carbonate of Soda.. 5 "
- Bisulphate of Soda.. 5 "
- Cyanide of Potassium 6 "

Dissolve three pounds, six ounces each of the sulphate of copper and zinc in hot water; dissolve ten pounds of carbonate of soda in

hot water, and add to the first. Let the mixture settle, then pour off water, and repeat two or three times; now dissolve five pounds each of carbonate and bisulphate of soda, and add; then dissolve six pounds of cyanide of potassium in hot water; add the other substances, and let the mixture set for two or three days before use.

COPPER SOLUTION.

- Sulphate of copper . . 10 lbs.
- Carbonate of soda . . 17 "
- Carbonate of soda . . 5 " 2 oz.
- Bisulphate of soda . . 7 " 6 oz.
- Cyanide of potassium 5 "

Dissolve first ten pounds of sulphate of copper, and seventeen pounds carbonate of soda; add together, wash, and repeat as in brass solution; now dissolve five pounds two ounces carbonate of soda, and seven

pounds six ounces bisulphite of soda; add; dissolve five pounds of cyanide of potassium and add. Let the mixture stand two or three days, then use.

The above solutions may all be used with the aid of a dynamo or common Bunsen or Smee cells. The solutions may be placed in jars or tanks, over which two brass rods are stretched, connecting with the poles of the battery. An anode corresponding to the solution in the jar must be attached by means of a copper wire to the rod connected with the positive pole, while the catode or article to be plated should be attached to the negative pole.

BRONZE.

This result is obtained by plating the article in copper or brass, and dipping it into a hot solution of sulphuret of potassium.

OXIDIZED SILVER.

Plate the article in silver, and dip it into a solution of either of the following: bichromate of potash, bisulphite of soda, persulphite of soda or chromic acid.

BRASS DIPS.

Equal parts of sulphuric and nitric acid to which a small quantity of muriatic acid is added, must be prepared. Cleanse as if to plate, that is, dip into hot potash, then into cold water before placing in the acid, where it must remain but for an instant, then at once into and shaken about in cold water, thoroughly washing off acid; then into hot water and saw-dust.

To secure the perfect cleanliness necessary to the article to be plated, there must be placed near at hand, solutions of boiling hot carbonate of potash, plenty of perfectly clean

BIPPART & CO.,

Newark, N. J.



INTERIOR VIEWS OF FACTORY.

Manufacturers of

FINE JEWELRY.

THE **RYDER & DEARIE** DESIGNERS & ENGRAVERS

Fine Commercial and Copper-Plate Printers.

A Specialty of *Jewelers' Printing, Cuts and Electrotypes.*

Headquarters for JEWELERS' CARDS.

BEST WORK,
PROMPT DELIVERY,
LOW PRICES.

No Order Too Large! None Too Small!

146 Westminster Street,

PROVIDENCE, - RHODE ISLAND.



JOHN B. YATES,

No. 147 NASSAU STREET, NEW YORK.

WATCHES

SPECIALTIES: UNITED STATES WATCHES.



I have a limited number of Discontinued American Waltham Gilt Hunting, price formerly \$12.65, same grade as the "Taylor" (Elgin) Movement, for \$10.50 Net.



ZIP!



Revolve these Rings in your mind, and you cannot help thinking of **OSTBY & BARTON**, the well known ring makers. 80 Clifford Street, Providence, Rhode Island.

hot and cold water and a solution of cyanide of potassium.

OPERATION.

First place the article which is attached to a copper wire, for a moment in the hot potash to remove all vegetable substance, then quickly plunge it into cold water, which should be running, then into cyanide; once more into cold water. The article is now chemically clean, and ready to be placed in the plating solution. Judgment must now govern the plater, when to remove the article and plunge quickly into clear cold water, and then immediately into the clean hot water, and last into the boxwood sawdust, where it must be shaken until dry.

If the article should now be dim from an excess of gold, a small wire scratch brush should be placed in the lathe, and the article gently brushed, all the time being kept moist by frequent dipping in a solution of soap and water. Silver may be brushed in the same way, but it is generally burnished. Nickel, copper and brass are buffed.

Prism Measure and Lens Centerer.

The illustration below depicts a new device for the use of opticians and oculists for the purpose of centering lenses, and also for measuring the degree of a prism or prisms, combined with spherical or cylindrical surfaces. The range of the work and the practicability of the instrument may readily be seen from an examination of the illustration.

For centering lenses, the instrument consists of a bed plate upon which is fixed a degree circle; hinged to the bed plate is an upper plate thrown up by a spring under it, An upright plate, with a degree circle at the top, stands at right angles to this upper plate. The index finger is made of steel, and pivoted to swing over any portion of the dial plate, at a point indicated by the white spot. In operation, the lens is placed upon

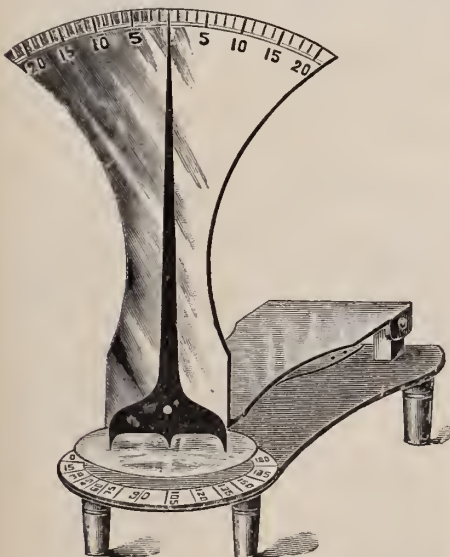

the lower points; these cannot be shown in the engraving, as they are covered by the lens. The upper plate is pressed down until the points of index touch the lens, and if of the

DIAMONDS.

Wm. S. Hedges & Co.,
Importers of Diamonds,

And Manufacturers of DIAMOND JEWELRY,
 No. 170 BROADWAY,
 S. E. Cor. Maiden Lane, } New York.
 27 Holborn Viaduct, London.



“ S ”

A “NOVELTY” in Marquis Rings.

ASK YOUR JOBBER FOR

STERN BROTHERS’ DIAMOND MOUNTINGS,

42 MAIDEN LANE, N. Y.

MAXHEIMER & BERESFORD,

MANUFACTURERS OF

FINE DIAMOND JEWELRY,

No. 3 Maiden Lane, New York.

ORDER WORK A SPECIALTY.

WILL REMOVE APRIL 15, TO
 189 BROADWAY.

R. A. Kipling

Importer of Precious Stones

31, Union Square
 New-York

19, Rue Drouot
 Paris

TO THE TRADE ONLY.

Balance Staffs, - 60 Cents.
 Inserting Pivots, 40 Cents.
 ALL OTHER WORK IN PROPORTION.
 SEND FOR PRICE LIST.
THOMAS JUZEK & CO.,
 ELGIN, ILL.

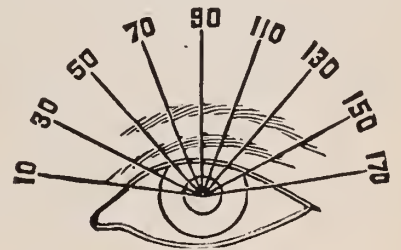

SEND TO

GENEVA OPTICAL CO.

23 Washington St., Chicago.
 FOR PRESCRIPTIONS, REPAIR AND ORDER WORK
 PROMPTLY AT LOWEST PRICES.

SEXTON BROS. & WASHBURN,

41 MAIDEN LANE, NEW YORK,

MANUFACTURERS OF

FINE JEWELRY,

INCLUDING A FULL LINE OF MOUNTINGS.

PROMPT AND CAREFUL ATTENTION GIVEN TO SPECIAL ORDER WORK.

A. N. CLARK, PLAINVILLE, } MANUFACTURER of the Celebrated
 CONN. }

LOOP WATCH KEY.

The best for the price in the World. Size
 of Square stamped on each Key.

Also Key Rings, Watch Case Springs,
 Jewelry Tools, Tweezers, Etc.

SEND FOR PRICE LIST. * SOLD BY ALL JOBBERS IN THE LINE AT MANUFACTURER'S PRICES.

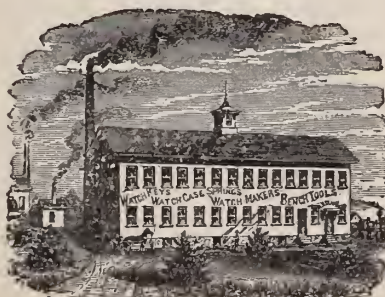

BURDON'S · SEAMLESS.

THE · ORIGINAL
And only Genuine



AND
Perfect Seamless Filled Wires
IN THE WORLD.
Sold to all Manufactur-
ers alike.

Burdon Seamless Wire.
TRADE-MARK.

The success of the BURDON SEAMLESS FILLED WIRE, like that of all important inventions, has been followed by deceptive and imperfect imitations. For the protection of

ALL JOBBERS AND RETAILERS,

we authorize manufacturers who so desire, to affix upon the tag, card or label accompanying the articles made from this wire, this registered trade-mark owned by this Company.

The bird-on-wire is a guarantee that the goods are made from the original Burdon Seamless Filled Wire, the reputation of which has been firmly established among the best dealers for more than two years. The perfection and qualities of the Burdon Seamless Wires are always guaranteed. All Dealers (jobbers and retailers alike) should, therefore, demand goods made from the original Burdon Wire, and avoid imitations which are offered as "just as good."

BURDON SEAMLESS FILLED WIRE CO.,
109 to 119 and 127 Summer Street,
PROVIDENCE, R. I.

TELL A. BEGUELIN,

IMPORTER OF
WATCHES,

Watch Materials, Tools and Glasses,
No. 71 NASSAU STREET,
(UP STAIRS.) NEW YORK.
Cor. John Street,
Sole Importer of Material for the
"Bijou," "Victor," "Boston," "Bristol,"
"Adelphia," "Jockey Club," "Wallingford,"
"Cæsar," "Lady Racine" and "New Haven"
Watches

Selling Agent for materials for **LONGINES**
and **AGASSIZ** Watches.
AMERICAN WATCHES,
ALSO STEM WIND WHEELS
Importer of Full Line of Swiss Watches,
AND FRENCH CLOCK GLASSES.

S. COTTLE & CO.,
MAKERS OF
FINE JEWELRY AND SILVER
NOVELTIES,
No. 86o Broadway, NEW YORK.

ARTIFICIAL EYES!

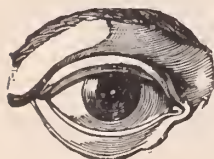

STOCK ORDERS of
Selection Packages.
Largest Assortment.

GENEVA OPTICAL CO.,
23 Washington St., Chicago.

R. & L. FRIEDLANDER,

Wholesale Jewelers,

AND

JOBBER IN AMERICAN WATCHES,

Tools, Materials and Optical Goods,

65 & 67 NASSAU STREET, N. Y.

Factory, 50 BOND STREET.

Send Business Card and we will mail you our Watch and Jewelry Catalogue, No. 12, and our Tool, Material and Optical Catalogue, No. 14.

READ THIS LETTER:

HENRY ERBSMEHL,

Watchmaker & Jeweler,

Watches, Clocks, Jewelry and Silverware.

MILFORD, DEL., March 4th, 1891.

MESSRS. R. & L. FRIEDLANDER, New York City.

GENTLEMEN: It gives me pleasure to recommend to the trade your Monarch Main Springs, for American Watches. They are, without exception, the best Main Springs that I have ever used. I have tried all makes within the last 25 years, but have found none equal to the Monarch Springs. They are uniform in force and temper; out of 6 dozen springs, I have lost but two.

I remain, yours truly,

HENRY ERBSMEHL.

Try our Monarch American Main Springs, **\$12.00 PER GROSS.**
\$1.00 PER DOZEN
POSITIVELY NO GOODS SOLD AT RETAIL.

Established 1872.

PLAINVILLE STOCK CO.

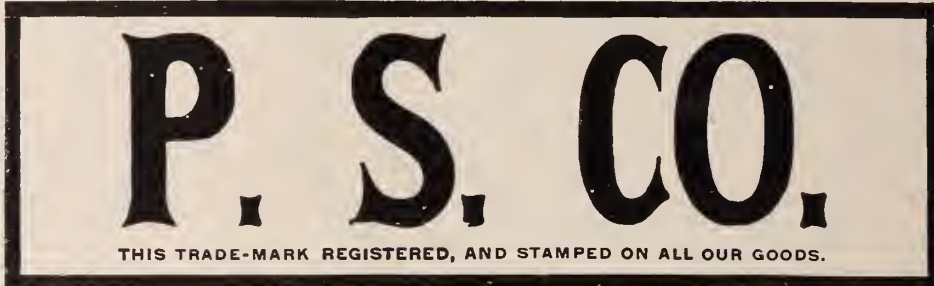

BROOCHES, SCARF PINS, DROPS, SETS.
FACTORY AT PLAINVILLE, MASS. SAMPLES AT 176 BROADWAY, NEW YORK

DIAMOND SETTINGS. GALLERIES. HOLLOW BALLS, ETC.

BLANCARD & CO.,

36 & 38 JOHN STREET,

SEND FOR OUR NEW YORK. CATALOGUE.

MUSICAL JACOT & SON,
298 Broadway,
New York
Send for Catalogue.
BOXES.
Musical Boxes Repaired.

GILBERT T. WOGLOM,
MAKER OF
BLACK Pearl Ornamented
and Plain
JEWELRY. **ONYX**
GOLD MOUNTED.
32 & 34 John St. New York City.

THE WALTHAM SCHOOL OF HOROLOGY,
D. D. PALMER, Teacher and Proprietor.
Best Advantages in the Country for Horological Instruction.

All branches under the personal supervision of D. D. PALMER, for a number of years in charge of the Adjusting Department of the Waltham Watch Co. POSITIONS GUARANTEED TO APT PUPILS. For terms and other particulars, address

D. D. PALMER,
WALTHAM, MASS.
Specialty of Difficult Repair Jobs.



same thickness as these points, the index finger will point to "o" on the scale, and the point in the lower center of the index finger will be exactly over the center of the lens.

For measuring a prism, the index finger will be governed by the difference of the thickness of the lens at the lower points of the index finger and the degree of the prism will be indicated on the scale by the finger.

The operations are quick and exact, and the value of the instrument at the present time, when so much attention is being given to the correct placing of the center of the lens, or adding a prism to correct ocular defects, is especially great. The device is manufactured by the Geneva Optical Co., Chicago, Ill.

The Austrian Museum.

WHEREAS South Kensington is disfigured by the "collecting" mania, and makes one feel as if one were visiting a gigantic bric-a-brac shop, the Austrian Museum shows, in every department, the influence of definite educational purpose in accordance with which all examples have been selected. The Museum has been completed by the addition of a library and print room, by various necessary dependencies, such as photographic studios and workshops, in which casting and other methods of reproduction are carried on by an industrial school, by a course for the training of teachers of drawing, and by a technical school of chemistry, in which experiments regarding the pottery, glass and enamel industries are pursued.

The authorities make a point of keeping close watch of all the leading manufacturers, many of whom have actually contributed to the expenses of the foundation of the museum, and they pay as serious attention to business questions in connection with the material interests of industry as they do the æsthetic side of their task. When the writer inspected the system pursued in the schools attached to the museum, he found that the Austrians had rejected all connection with the Academy, not that the authorities had failed to recognize the fact that the fine arts and the industrial arts take their origin in the same principle and obey the same laws, but they believed certain advantages were to be obtained, both as regards practice and the higher forms of instruction by their separation. Instead, therefore, of trying to give anything like a complete and general artistic education, the directors of the Austrian Museum have decided on a scheme of special schools. Of these schools there are three. The first includes all the subsidiary arts of building; that is to say, all that regards the interior arrangement of rooms, all articles of furniture or of decoration, whether in wood, metal, stone or pottery, to which the principles of construction have to be applied. The second school is devoted to every craft which demands a knowledge of the sculptor's art, such, for example, as certain branches of cabinet making, stucco decoration and goldsmith's work.

The "GENERAL SHERMAN" Souvenir Spoon



We have spared no expense in producing this interesting "National Spoon." We find that our customers appreciate skill in modeling as well as artistic workmanship, and that they purchase this spoon, tho' apparently high priced, just as quickly at \$5.00 each as the "Peter Stuyvesant" Coffee Spoon at \$4.00, or the "Rip Van Winkle" Tea Spoon (illustrated in the March 25th number of THE CIRCULAR), at \$3.00.

Dealers to whom we give a discount of 20 per cent. on the "General Sherman," "Peter Stuyvesant" and "Rip Van Winkle" spoons, will find an immediate demand and realize a fair profit. Orders promptly filled.

We allow a discount of 15 per cent. on our "Knickerbocker" and all other Souvenir Spoons.

The "Peter Stuyvesant" Coffee Spoon, \$4.00.



THE "KNICKERBOCKER" ORANGE SPOON, \$2.50.



Send for Price List and Illustrations of all our Souvenir Spoons.

J. H. JOHNSTON & CO.,
17 UNION SQUARE, NEW YORK.

Ludwig Assen
Alex. Wiederhold
18 JOHN ST. NEW YORK.

MOORE & HORTON,
MANUFACTURERS OF
SOLID GOLD JEWELRY,
No. 11 Maiden Lane, New York.
Fine Imitation Diamond Goods a Specialty.
Selection Packages sent on Application.

The New Trenton



18 SIZE, SEVEN JEWELS, NICKEL.
HUNTING AND OPEN FACE S. W.

Quick train, straight line lever escapement, safety centre pinion, enamel dial, beautifully damaskeened and exceedingly attractive in appearance.

**THE BEST LOW PRICED WATCH
EVER PRODUCED.**

For Sale by the Jobbing Trade.

TRENTON WATCH CO.

TRENTON, N. J.

ALEX. WIEDERHOLD,
20 MAIDEN LANE, N. Y.,
REPAIRING JEWELER.

Jobbing sent to me by mail or express will be repaired and returned promptly. Prices Moderate and First-class Workmanship Guaranteed.

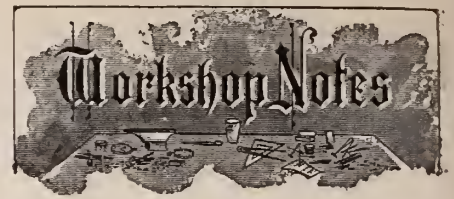

Nice Soft Gold Solder.—A nice soft solder for 8 and 14-karat gold consists of $\frac{1}{2}$ parts fine solder, $\frac{1}{2}$ part fine copper, $1\frac{3}{4}$ parts 14 karat gold, and $\frac{1}{4}$ part zinc. The first three metals are well melted and mixed together, and when in a fluid state, add the zinc; leave the whole for a few moments in fusion, so as to melt, but not volatilize the zinc, then cast.

Soft Gold Solder.—Melt equal parts of 14-karat gold and silver solders, and hammer the matter into a thin sheet upon the anvil. This solder will satisfy all the demands of the watch repairer or jeweler. Use silver solder for a low grade, say 6 or 8-karat gold grade. Such a solder consists of 2 parts fine silver and 1 part brass, with the addition of a few grains of tin.

Fusible Bronze.—A very fusible bronze is obtained by the addition of tin; but by adding too much of it the bronze becomes dry and especially in using it for large articles, where an unfavorable straining or tension takes place; it cracks quickly. To avoid this, the bronze should be composed of 82.-45 parts copper, 10.30 parts zinc, 4.10 parts of tin, and 3.15 parts of lead.

Shape of Pivots.—Pivots should be cylindrical, well tempered, with a shoulder or bearing at right angles, but rounded at the end; the same may be said of the pivot holes. The material entering into their composition must not be easily oxidized by the action of the oil, and it is advantageous to have them somewhat olive-shaped inside, with ends lemon-shaped and extending beyond the oil sinks. They should bring the oil to the pivots, and for this the sharp-angled pivot is the best.

To Clean Dull Gold.—Dull gold may be cleaned by immersion in a bath of 80 grams calcium hypochlorite, 80 grams sodium bicarbonate, and 20 grams table salt, all of which ingredients are dissolved in 3 quarts distilled water. The fluid must be kept for use in well-corked bottles. Articles to be cleaned are placed in a basin and covered with the liquor, and taken out after awhile, washed and rinsed in alcohol, and dried in sawdust. The articles then look like new.

To Harden Gold Springs.—A high degree of elasticity may be imparted to gold detent, thermometer, suspension balance and other springs; rolling hardens but makes them brittle. They can be made pliable and elastic, not by hardening, as in the case of steel, but by annealing, care being taken not to exceed a certain degree of heat. The spring may be coiled on a block and placed in a tube, with a smooth steel lid; the tube is then heated in the flame of a spirit lamp, and as soon as the steel is of a blue temper the whole is removed and allowed to cool.

"ABOUT A HOOP OF GOLD, A PALTRY RING THAT SHE
DID GIVE ME."—SHAKESPEARE.

HILDRETH MANUFACTURING COMPANY,

53 MAIDEN LANE, NEW YORK.

PLAIN SOLID GOLD RINGS AT LOWER PRICES THAN YOU
ARE PAYING. SEND FOR SAMPLES. QUALITY GUARANTEED.

KENDRICK & DAVIS,

LEBANON, N. H.

MANUFACTURERS OF THE

Standard Dust Proof Watch Key.



*After this date all Keys of this Style will have number
stamped on each Key.*

FOR SALE BY THE TRADE.



PATENTS FOR INVENTIONS.

A design for jewelry pins, consisting of a piece of metal in the shape of a spoon or fork two inches long, precisely similar to common spoons or forks six inches long, lacks the novelty necessary to support a patent.

INJURIES TO PASSENGERS.

A passenger on a train, after being carried beyond his station while asleep, was awakened, and at his request the train was stopped that he might get off and walk back. While so walking, he narrowly escaped being run into by a freight train on a trestle. He was afterwards sick from the effect of the excitement. He had no redress against the company, though the conductor misled him as to the exact place where the train was when he got off.

DAMAGE TO GOODS IN TRANSIT.

In an action by a shipper against a railway company for clay pots damaged in transit, there is a proper case for the consideration of the jury, when it is shown that the pots were sound, and carefully packed in the car, but that they were shifted about, and badly damaged when received, though similar pots, packed in like manner, had uniformly arrived unbroken. Though there is no proof of collision or derailment, the question of negligence is one of fact for the jury.

PENALTIES FOR OVERCHARGE BY RAILROAD COMPANIES.

Under a statute of Texas, denouncing a penalty of \$500 against a railroad company, exacting higher rates of freight than the maximum rate fixed by law, a company which receives freight, and delivers it to a connecting carrier, is not liable to the penalty because of an overcharge by the latter company. A railroad company is not liable to the penalty prescribed for detaining freight after payment or tender of the charges as shown by the bill of lading, when the freight is detained by a connecting line to which it has been delivered, together with the bill of lading.

SUITS FOR INFRINGEMENTS.

A defendant in a patent suit, who was the manufacturer of certain articles claimed to be an infringement of plaintiff's patent, sought to obtain an order enjoining the prosecution of their suits begun in other districts against its customers as well as the commencement of new suits, and the sending of letters and circulars to others engaged in the trade, threatening prosecution for selling articles made by the defendant. The prosecution of suits in other districts should not be enjoined because such suits were begun before this suit, and because comity demanded that application should be made to this court in which such suits were pending.

A. WITTNAUER,
30 Maiden Lane, New York,
MAKER OF
COMPLICATED * WATCHES.

TIMING WATCHES
OF ALL STYLES.



SPLIT SECONDS
AND
Minute Repeaters.

VARIOUS GRADES, ALL ACCURATELY MADE.

Also Sole Agent for the Celebrated **LONGINES & AGASSIZ** Watches.

ESTABLISHED 1873.



If for any reason you should desire the services of an **AUCTIONEER**, and will write me as to the amount of stock you have on hand and its general character, the size of your store and the number of inhabitants of your town or city, I could, from my extended experience, give you an idea of the amount of business you could expect under the circumstances, and, no doubt, be able to refer you to some one for whom I have sold under conditions similar to your own.

As a general reference, you could hardly find a wholesale jeweler who is not familiar with some of the numerous successful sales I have made.

I have made many successful **AUCTION SALES**, and have yet to record a failure to fully satisfy the owners. Can give you hundreds of references to that effect.

If the business should be urgent and I am myself engaged, I have two competent assistants instructed in my methods whom I could send on short notice.

Any correspondence with me will be strictly confidential in every case.
P. O. Box 2775.

NEW YORK CITY.



Issue of March 31, 1891.

DESIGN No. **20,644**. HANDLE FOR SPOONS, FORKS, ETC. WILLIAM B. DURGIN, Concord, N. H.—Application filed Feb. 16, 1891. Serial No. 381,704. Term of patent, 7 years.

DESIGN No. **20,645**. BADGE. CHARLES F. IRONS, Providence, R. I.—Application filed Feb. 2, 1891. Serial No. 379,920. Term of patent, 14 years.

DESIGNS Nos. **20,649** and **20,650**. SPOON, ETC. ROBERT LEDING, Washington, D. C.—Applications filed March 5, 1891. Serial Nos. 383,915 and 383,916. Term of patents, 7 years.

DESIGN No. **20,653**. SPOON OR FORK HANDLE. HAVERLEY BROOKS SWART, Worcester, Mass.—Application filed Feb. 9, 1891. Serial No. 380,829. Term of patent, 3½ years.

DESIGN No. **20,655**. SPOON. EDWARD C. BAUMGRAS, Washington, D. C., assignor to Jacob Brothers, same place.—Application filed March 9, 1891. Serial No. 384,352. Term of patent, 3½ years.

DESIGNS Nos. **20,657** and **20,658**. SPOON, ETC. EDWARD HARRIS, Washington, D. C.—Applications filed March 4, 1891. Serial Nos. 303,913 and 303,914. Terms of patents, 3½ years.

449,103. BRACELET. CARL BACHEM, Pforzheim, Baden, Germany.—Filed Oct. 10, 1890. Serial No. 367,747. (No model.)

449,182. PROCESS OF MANUFACTURING SEAMLESS HOLLOW WIRE. CHARLES R. SMITH, Providence, R. I., assignor to the C. R. Smith Plating Co., of Kentucky.—Filed July 24, 1890. Renewed Feb. 18, 1891. Serial No. 381,973. (No specimens.)

449,183. PROCESS OF MANUFACTURING SEAMLESS GOLD-PLATED WIRE. CHARLES R. SMITH, Providence, R. I., assignor to the C. R. Smith Plating Co., of Kentucky.—Filed July 24, 1890. Renewed Feb. 18, 1891. Serial No. 381,974. (No specimens.)

449,192. APPARATUS FOR RECORDING MEASUREMENTS OF TIME, SPACE, OR QUANTITY. HENRY ABBOTT, Newark, N. J.—Filed Nov. 21, 1888. Renewed Sept. 2, 1890. Serial No. 363,749. (No model.)

In a machine for measuring intervals, a rotatable dial, provided upon its face with a series of progressive characters, and an independently-moving pointer.

449,255. WATCH BOW FASTENER. EMIL KLAHN, Jersey City, N. J., assignor to the Keystone Watch Case Co., Philadelphia, Pa.—Filed Jan. 2, 1891. Serial No. 376,536. (No model.)

449,310. WATCHMAKER'S PLIERS. EDWIN

E. COBLE, Elizabethtown, Pa.—Filed June 10, 1890. Serial No. 354,972. (No model.)

The combination of a bifurcated jaw and a jaw having a pin, lug, or teat formed on the inner face thereof, opposite the slot, dividing the ends of the bifurcated jaw.

449,370. TRAVELERS' WATCH CASE. EDWARD A. LAUTEN, Mount Vernon, N. Y., assignor to Albert Wittnauer, New York.—Filed Nov. 4, 1890. Serial No. 370,262. (No model.)

The combination, with a case formed of two hinged sections, of a watch-holding pocket, hinged at one side to one side of one section, and a cushion or stop for the crown, secured to the top of the interior of that section to which the watch-holding pocket is hinged.

449,428. METHOD OF MAKING SEAMLESS PLATED WIRE. IRA F. PECK, Providence, R. I.—Filed Nov. 20, 1890. Serial No. 372,082. (No model.)

449,531. OPERA GLASS HOLDER. JOSEPH V. GEROW, Brooklyn, N. Y.—Filed Oct. 9, 1890. Serial No. 367,573. (No model.)

449,605. EYEGLASSES. WALTER C. WESTAWAY, Decorah, Ia., assignor of one-half to Harry C. Goddard and George I. Leonard, both of the same place.—Filed Aug. 25, 1890. Serial No. 362,940. (No model.)

A pair of eyeglasses, having a spring-actuated bow pivotally connected to one of the glasses, and a connection extending to the outer end of the latter glass, by means of which the bow may be turned on its pivotal point.

★ ROGERS & BRO. A-1.



OLDEST BRAND AND HIGHEST GRADE OF
ELECTRO SILVER PLATE.

ROGERS & BROTHER, Manufacturers,

16 Cortlandt Street, New York.

Waterbury, Conn.

□ HOLLOW WARE.

Price Lists upon Application accompanied by Business Card.

HENRY FERA,
IMPORTER OF DIAMONDS,
AND DIAMOND BORTZ,
Diamond Cutting and Polishing Establishment,
10 Maiden Lane, NEW YORK.

WOOD & HUGHES,
Sterling Silverware Manufacturers.
New York Agents for the Derby Silver Co.'s
FINE QUADRUPLED PLATED WARE.
No. 16 JOHN STREET, - NEW YORK.
206 Kearney St., San Francisco, Cal.
HASKELL & MUEGGE, Agents.

Jules Jürgensen
OF COPENHAGEN.
The reputation these watches have maintained for Fifty Years has never been equalled, being made on strictly scientific principles, and no expense spared to give the Best results in mechanism and timekeeping qualities.

SOLE AGENTS,
John E. Hyde's Sons,
No. 22 MAIDEN LANE.

ESTABLISHED 1837.
GEO. O. STREET & SONS,
MAKERS OF
Fine Rings, Locketts, Seals, Sleeve
Buttons and Links,
15 John Street, - NEW YORK.

ELGIN HOROLOGICAL SCHOOL
ELGIN, ILL.

SEND FOR CIRCULAR.
Repairing for the trade. Repair price list free.

ESTABLISHED 1855.
BUSCHEMEYER & SENG,
Diamond Setters and Manufacturing Jewelers,
DIAMOND MOUNTINGS,
Estimates Solicited on Special Order Work,
342 WEST MARKET STREET,
LOUISVILLE, KY.

ESTABLISHED 1841.

CARTER, SLOAN & CO.

MANUFACTURERS OF

FINE JEWELRY,

15 MAIDEN LANE,

NEW YORK.

A. CARTER, JR.
A. E. SLOAN.
C. E. HASTINGS.
GEO. R. HOWE,
WM. T. CARTEP.



Factory, NEWARK, N. J.



The Poise of the Balance.

PHILADELPHIA, Pa., March 7 1891.

To the Editor of the *Jewelers' Circular* :

In one of your recent issues, speaking of the length of balance pivots, you state that the balance must be put sufficiently in poise, and that it must be remembered, however, that the balance is sometimes put out of poise intentionally. Will you please state: first, Under what circumstances is the balance put out of poise? Second, Can it be ascertained when the balance is put out of poise intentionally? I know some workmen who boast of having every balance poised they have in hand, whether anything has been done to the watch or not in the way of repairs, as a new staff, or pivot, etc. For example, they will take a new watch, either fine, medium, or low quality, and if it is a little out of poise they will alter or file screws until they are satisfied. Is this good practice?

NOVICE.

ANSWER.—To answer the last question of "Novice" first. No, sir it is not; yet it is a rare case that a watchmaker will with, say, an ordinary cylinder watch enter into much elaborate work, as the remuneration does not stand in proportion to the trouble occasioned. It sometimes happens that after a great waste of time and labor, the watch cannot be closely regulated, and the last resource is to destroy the poise. English watchmakers, also are charged with occasionally resorting to this shift, the timing of a fusee watch being more difficult than that of timing one with a going barrel. "Novice" will find an essay by Cl. Saunier, on "Timing in position" in our last issue, to which he is referred.

Praise Where Praise is Due.

GLOVERSVILLE, N. Y., March 28, 1891.

To the Editor of *The Jewelers' Circular* :

Through the efforts of the Jewelers' Security Alliance, we have convicted James Donovan, one of the men who robbed my safe last June. I wish to say that I am well pleased with the work the Jewelers' Security Alliance has done for me and advise all jewelers to join it. I write you this as I have a number of letters from jewelers wishing to know how I was pleased with the Alliance.

Respectfully yours,

A. D. NORTON.

A Good Price for One Number.

BILLINGS, Mo., March 21st, 1891.

To the Editor of *The Jewelers' Circular*.

I would like to get the February number of *JEWELERS' CIRCULAR* for 1887. Am willing to pay a good price for same.

WILLIAM WATKINSON.

The demand for the antique is by no means on the wane; in witness whereof are any number of copies in silverware for the table. A style that seems to hold the popular favor in tea sets is the low fluted Queen Anne shape, in bright finished silver with ebony handles.

N. KOCH.

L. DREYFUS.

J. KOCH.

I. PFORZHEIMER.

KOCH & DREYFUS,

22 John Street, New York.

IMPORTERS OF DIAMONDS,

JOBBERS OF

AMERICAN WATCHES,

Diamond Novelties and Jewelry

We have now a complete line of Goods and Specialties on hand and on the road in charge of following representatives :

JONAS KOCH, GEO. MALLET, L. GOLDSMITH,
HENRY HEYMAN, A. ROSENTHAL.

WATCH * CASE * REPAIRING

WITH MY



IMPROVED MACHINERY and INCREASED FACILITIES,



I am enabled to do your work

BETTER,

QUICKER AND

CHEAPER.

IT IS TO

YOUR ADVANTAGE

TO GIVE ME A TRIAL.

G. F. FEINIER,

Manufacturer of Watch Cases; also Repairing of Every Description.

No. 9 Bond Street, New York.

Key-Wind Cases Altered to Stem-Wind, and made same as New. English Cases Altered to take American Movements.

REFERENCE: ROBBINS & APPLETON, NEW YORK.

The Other Side of Life.

OPTICIAN—I must fit you with strong glasses.

PROHIBITIONIST—Then I must go elsewhere. I will have nothing strong.

QUEER FACT.

"It's a rather inconsistent state of affairs," suddenly exclaimed Knowles.

"What is?" naturally inquired Bowles.

"That a watch which always has a balance, must also have tick."

PREJUDICED AGAINST POVERTY.

"Yes," said the Chairman of the World's Fair Committee, "we must have the real Venus of Milo."

"You know the real Venus is broke," ventured the commissioner.

"Broke? That settles it. We want no one who shows such lack of business knowledge as to get broke. Venus should have gone into the hog business."

A DIFFERENCE OF IDEAS.

FASSETT—I met Horace Fledgely, to-day, and he seems prostrated by your refusal of him.

ALICE—We never could agree in the world. When he proposed to me, I asked him his idea on engagement rings, and what do you think he said? A nice oxidized silver friendship ring was his ideal. We parted.



C. H. DREYFUS

INNOCENT CANDOR.

THE LADY.—Mary, you may clean the diamond in this ring; it looks very dull and dirty.

THE MAID.—Shure, Mum, I'm just afther cleanin' it; Oi think it nades a new coatin' on the back of it.

—Smith, Gray & Co.'s Monthly.

One swallow does not make a spring. Neither does a watchmaker nowadays. He usually buys it.

DUSTE HAD A GOOD MEMORY.
 PONSONBY—I'm becoming quite tired of old Duste. He's treating me very shabbily.
 POPINJAY—What's up now?
 PONSONBY—I wanted to go to the races last Monday, so I told him my grand-uncle was dead. What do you think he said?
 POPINJAY—Can't guess.
 PONSONBY—He said my grand-uncle usually dies on Fridays, and declined to let me off.

NO FAULTS.

MERCHANT—You want a position as office boy, you say. I suppose you have no particular faults?

BOY—Naw. I ony smoke in der office, spit over der floor, read der newspapers, put me feet on der desk, chew terbaccer, and curse.

MERCHANT—Oh, those are nothing. Don't mention them. How much do you want a week?

TO BOOM GOLD COLLAR BUTTONS.

CHOLLY CHOLMONDELEY—That coat doesn't seem to fit you, deah boy, about the neck.

HAROLD HARRINGTON—It does. It is called a good collah button encouragah, doncherknow.

CHOLLY CHOLMONDELEY—Queer. And wherefore, deah boy?

HAROLD HARRINGTON—The collah button shows at the back, doncherknow; and a gold button looks bettah than a blooming bone one, doncherknow.

**EZRA KELLEY'S
 Famous Watch, Clock and Chronometer Oils,**

RECEIVED AT THE
 EXHIBITION UNIVERSELLE, PARIS, 1889,

The only Award of Merit given to Manufacturers of American Oils

It is to the interest of every Watchmaker to use in his work the *Best Oil* obtainable, regardless of cost. Mr. Kelley's claim to be the foremost manufacturer of Oils, giving the best results, is not based upon his own assertion, but is founded upon the fact that wherever his Oils have been exhibited in competition with other makes, subject to an examination of experts, they have received the highest *Award of Merit*.

For sale by all the Leading Jobbing Houses.

HENRY GINNEL & CO.,

GRIMSHAW & BAXTER, EUROPEAN AGENTS,
 35 GOSWELL ROAD, LONDON, ENGLAND.

GENERAL AGENTS,
 31 Maiden Lane, NEW YORK

LOUIS NEWMAN, JR.

GOLD AND SILVER

Plater, Fire Gilder and Colorer.

Gilding by a New Process. Watch Cases, Jewelry and Novelties, Work stands acids, and in finish equal to Gold.
 36 & 38 JOHN STREET, NEW YORK.

**WIGGERS & FROELICK,
 60 NASSAU ST., NEW YORK,**

Sample Cases and Trays

For Watches, Jewelry, Optical Goods, Etc.

WE STRIVE TO MAKE THE BEST

**TO THE TRADE.
 FINE WATCH REPAIRING**

BY
**JOHN C. SIMMONDS,
 18 JOHN STREET, NEW YORK.**

New pieces, such as Chronometer Locking Springs, Balance Staffs, &c., made in the best styles. Watches sprung and adjusted to temperature and positions.

THE LATEST PARISIAN NOVELTY.



MANUFACTURED BY
**CROSSIN & TUCKER,
 400 Pine Street, Providence, R. I.**

GENTLEMEN:—I think the trade this Spring will be better than last, and, although I can turn out double the work I did then, you had better be on hand with your orders, for I expect that my sales will be very large—equal to last Fall, if not double. You see the field is constantly widening and the demand is increasing, and why? Did you ever stop to think that there are 65,000,000 people in the United States, and the per cent. of this number that use glasses is one-fifth, or 20 %, making 13,000,000 people wearing eye-glasses, and if you count the myriads in Europe and South America, why it is simply immense, and it needs cultivation. Why! Gentlemen, we ought to be able to double our business every year for the next ten years.

Yours respectfully,
 Springfield, Mass. S. F. MERRITT.

Essex Watch Case

COMPANY,

T. B. HAGSTOZ, President.

TRADE MARK



6 Maiden Lane, N. Y.

OFFICE,

NEWARK, N. J.

FACTORY,

GOLD FILLED CASES.

HAVE YOU TAKEN YOUR INVENTORY?

HAVE YOU REMEMBERED? —Old gold or silver? If so, —That we pay 4 cents per kt. for gold and highest market price for old silver.

HAVE YOU REMEMBERED? —On hand a collection of old plated jewelry filings, sweeps, etc., or a lot of old jobs, which have been on hand for years, with no likelihood of being called for.

HAVE YOU REMEMBERED? —A lot of old style and unsalable jewelry on hand? If so, it would be good policy to dispose of same, convert the proceeds into an article that you would probably turn over several times, besides give your stock a nice, clean appearance.

OUR PLAN —Immediately on receipt of shipment, we will remit by cash or draft (as desired). If our offer should not prove satisfactory, we will return consignment in exactly same condition as received and pay all charges. By this arrangement you are absolutely safe, as it is no sale unless our offer should prove satisfactory, and you run no more chances than if you were disposing of same right over your counter. —Send for our little book giving pointers on testing and buying gold and silver. Mailed free on application.

GOLDSMITH BROS.

Gold and Silver Refiners and Assayers,
63 & 65 WASHINGTON ST., CHICAGO, ILL.

Columbus, Ga., Jan. 10, 1891.
Dear Sirs: Yours of the 7th inst. to hand, containing check for \$29.88. All satisfactory. Accept thanks.
Yours truly,
C. M. KINSEL.

Denison, Tex., Jan. 6, 1891.
Goldsmith Bros., Chicago, Ill.
Gents: Your draft of Jan. 3, '91, came to hand this day. Amount very satisfactory, (\$112.93).
Very Respectfully,
B. W. MERRILL.

Los Angeles, Cal., Jan. 6, 1891.
Messrs. Goldsmith Bros., Chicago, Ill.
Gentlemen: Your favor duly to hand, containing check for \$176.64, which is satisfactory to us.
Yours,
J. F. GRANAS & CO.

Little Falls, N. Y., Jan. 12, 1891.
Dear Sirs: Your favor of Jan. 9 received, which is satisfactory. Respectfully,
ANDERSON & HOUGHTON.

Keokuk, Iowa, Jan. 3, 1891.
Gentlemen: Accept thanks for check for \$153.58 in settlement for old silver.
Yours Resp'y,
T. R. J. AYRES & SONS.

Decatur, Ill., Jan. 19, 1891.
The check for \$65.45 is all satisfactory.
O. E. CURTIS & BRO.

4 Center Ave., Pittsburgh, Pa.
Gentlemen: \$54.32 received for old gold. Thanks. Am satisfied beyond expectation.
Respectfully,
H SCHEINEMAN

Milwaukee, Wis., Jan. 23, 1891.
Gents: Your favor of yesterday, inclosing check for \$205.80, to hand, which is very satisfactory.
Yours truly,
C. PREUSSER JEWELRY CO.

St. Cloud, Minn., Jan. 2, 1891.
Gents: Your check of \$12.01 is very satisfactory, more than we expected to get. Many thanks.
Respectfully,
GEO. R. CLARK & CO.

Moberly, Mo. January 2, 1891.
Goldsmith Bros.
Gents: Your express order for old gold received. Same satisfactory. I get a great deal of old gold and silver, and have sold same in New York and Philadelphia, but have never received what I thought full value until I commenced sending to you. This is my ninth shipment to you.
Respectfully,
A. F. SELEN.

DIAMANTA
Spectacles and Eye Glasses are the best
M. ZINEMAN & BRO.,
130 South Ninth St., Philadelphia.

DIAMANTA

A Wonderful TOOL FOR THE BENCH.
Instantaneous in Its Work.



Dividing the inch into one thousand parts. A most practical tool for watchmakers for gauging from a hair-spring to a main-spring. Non-comparable for a height and depth gauge. Instantaneous for hair-spring work.

For sale by all Jobbers.
NORDMAN BROTHERS,
120 Sutter St., SAN FRANCISCO, CAL.
Sole Agents for the United States.

T. B. BYNNER,
Dealer in
Diamonds, Opals, Pearls,
AND EVERY VARIETY OF PRECIOUS STONES,
in varied and novel combinations.
177 BROADWAY, NEW YORK.

RUSSELL HOUSE,
DETROIT, MICH.
Always a Favorite of the Jewelers, for the following (three) reasons:
1st—Excellence of its cuisine. 2d—Its central location to the trade they visit. 3d—Ample security its spacious vaults offer for samples and valuables.
CHITTENDEN & McCREARY, Prop'rs



The Latest "PURITAN" Design.

RICH CUT GLASSWARE.



Headquarters in America for
ART GLASSWARES,
RICH CUT AND DECORATED.
Lamps, Vases and complete lines of everything for table use or household decoration.

MT. WASHINGTON GLASS CO.
NEW BEDFORD, MASS.
NEW YORK OFFICE, 46 MURRAY STREET.

CATALOGUES FOR ♦ ♦ ♦ ♦
INTENDING PURCHASERS.

FALKENAU, OPPENHEIMER & CO.,



40 MAIDEN LANE, NEW YORK.

P. O. BOX 3314.

CHAS. S. PLATT,

1837. Successor to George W. Platt, 1881.

GOLD AND SILVER

Refiner, Assayer and Sweep Smelter.

Office and Refinery,

29 & 31 GOLD ST., near John St., NEW YORK.

Platers' and Electro-Platers' Silver-Platinum and Aluminum.

Workshops to let, with power. Fine Light—special for Jewelers. All improvements. Apply as above.



S. P. HOWARD,

Gold and Silver Assayer,

Refiner and Sweep Smelter,

8 & 10 JOHN STREET, NEW YORK.

Smelting and Refining Works,

28, 30 & 32 Cumberland St., Brooklyn, N. Y.

Specialties: Sweepings, Gold, Silver and Platinum.

IF YOUR JOBBER DOES NOT CARRY A FULL LINE OF "ROGERS & HAMILTON" PLATED WARE HIS STOCK IS INCOMPLETE WRITE THE FACTORY. WATERBURY, CONN.

ROBERTSON & LEBER, GOLD, SILVER AND

PLATINUM

REFINING.

PLATINUM SCRAPS MELTED.

13 & 15 FRANKLIN STREET, NEWARK, N. J.

JEWELERS' SWEEPINGS A SPECIALTY.

S. F. MYERS & CO., Wholesale Jewelers.

EVERYTHING THAT PERTAINS TO THE JEWELRY TRADE. 22 DEPARTMENTS.



WE REQUIRE AND OCCUPY THE LARGEST SALESROOMS IN OUR LINE. 4 STORES. GROUND FLOOR.

48 & 50 Maiden Lane and 33 & 35 Liberty Street, New York. CONSULT OUR MAMMOTH CATALOGUES.

L. LELONG & BRO.,

GOLD AND SILVER

Refiners, Assayers and Sweep Smelters,

SWEST CORNER HALSEY AND MARSHALL STREETS, NEWARK, N. J.

SWEEPINGS A SPECIALTY.

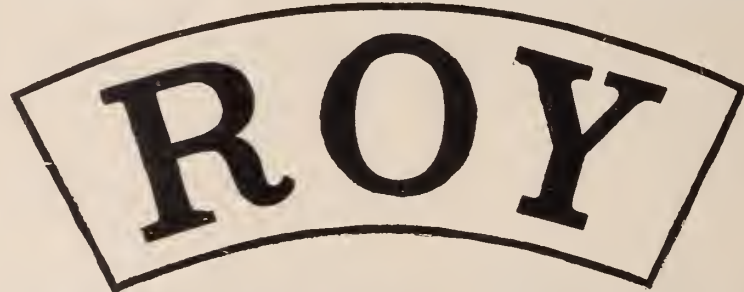

ALL OTHER GOLD FILLED CASES COMPARE WITH THE CELEBRATED CROWN LION, EXPANSOR HAND ENGRAVED CASES MADE BY H. MURR'S SONS

Gold AND Diamond Jewelry

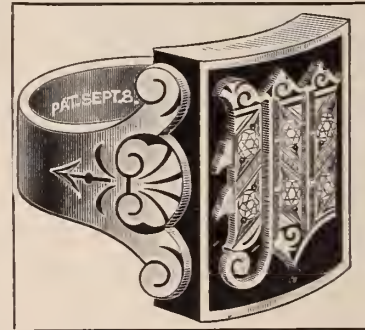
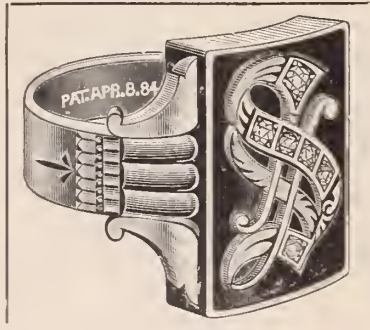

Gents' Seal, Ladies' Fancy, Children's Rings.

ALBERT LORSCH & CO., 37 Maiden Lane, New York. P. O. BOX 2139.

167 Broad St. (P. O. Box 941), Providence, R. I.

IMPORTERS OF

DIAMONDS, PRECIOUS AND IMITATION STONES.

Sole owners and Importers of

Unequaled in

The Sumatra Gem. REG'D.

Brilliance.

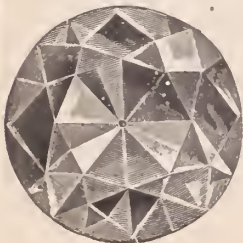

The nearest approach to the Genuine Diamond. For sale by all leading Manufacturers and Jobbers. * All Jewelry set with these Stones is sold on cards stamped "The Sumatra Gem. Reg'd."

REMOVED.

GUNZBURGER BROTHERS, Importers of Diamonds FROM 25 TO 35 MAIDEN LANE.

CIRCULATION
 FEBRUARY 40 150
 MARCH - 40,155

SOUVENIR SPOON SERIES
 NO. 4.

LARGEST CIRCULATION
 OF ALL THE
 JEWELRY JOURNALS.



Entered at the Post Office in New York as second-class matter.

VOL. XXII.

NEW YORK, WEDNESDAY, APRIL 15, 1891.

No. 11.

SOUVENIR SPOONS.

PART IV.

WHEN on the morning of Feb. 14 it was telegraphed throughout the country that General W. T. Sherman, the last of the immortal trio—Grant, Sheridan and himself—who brought the war for the

blemish. Abounding in vitality and intellectual resources, taking the heartiest interest in the events of the day and in social enjoyments, a splendid specimen of stalwart manhood and of the true American soldier

will ever be associated in American patriotic traditions for many centuries to come.

It would therefore have been surprising that if during the existence of the souvenir spoon fad, a spoon to commemorate this

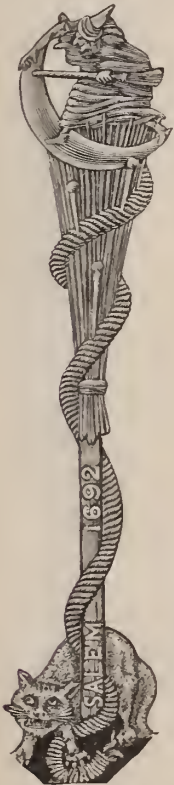

NEW WITCH.



A GROUP OF AMERICANS—LINCOLN, SHERMAN AND GRANT.



SARA BERNHARDT.

Union to its close, had expired, sorrow was expressed on all sides, for the deceased was universally honored and beloved. His life had been one, full of grand achievements and patriotic deeds, while unmarred by a single

and citizen he looked, he was the typical American, whose presence in public or in society incited the pride and enthusiasm of all true Americans. His fame was secure and his place in history will be distinct. He

historic figure had not been produced.

The National spoon which J. H. Johnston & Co., New York, have designed, contains a full relief bust of the general, at the top of the handle. The die is cast from the

photograph which Sherman especially liked, made by Sarony, the greatest photographer in America. The likeness is perfect, the modeling being particularly fine and artistic. The bust rests apparently upon a bed of

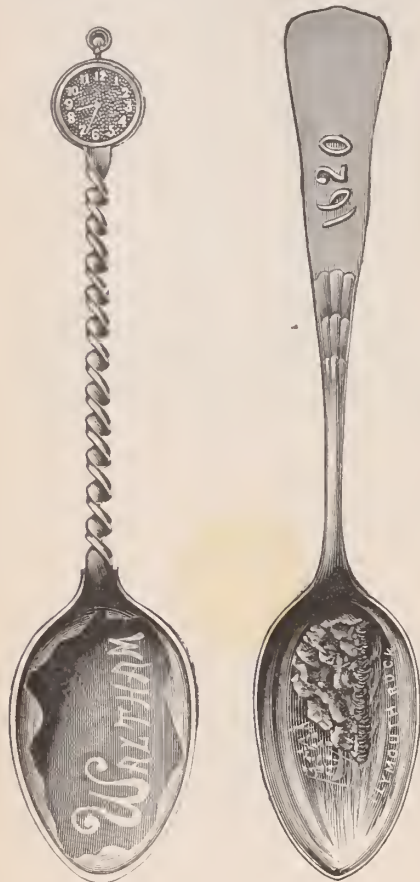

WALTHAM. PLYMOUTH ROCK.

laurel. A national flag appears wrapped around the shank of the handle, above which the hilt of a sword is seen. The flag twines to the bowl, sprigs of laurel showing between the folds. The character of the modeling is very massive, though the spoon retains its utility. The front of the handle and the back of the head are oxidized, the remainder being bright finished. The spoon is made in tea size.

THE SIR WM. JOHNSON.

In the history of the town of Johnstown, N. Y., no name stands higher than that of Sir William Johnson. He won his baronetcy through his successful campaigns against the French and their savage allies in 1755, during the French and Indian war. In the spring of 1763, he built the stately mansion that still stands in Johnstown, and is the chief historic landmark of that town and the surrounding regions. "It was from this spot", has said Ex-Governor Seymour, "that the agents went forth to treat with the Indians of the West and keep the chain of friendship bright. Here came the scout from the forests and lakes of the North, to tell of any dangerous movements of the enemy. Here were written the reports to the Crown, which were to shape the policy of nations." The hall is a wooden building sixty feet in length by forty feet in depth, and two stories high, at both ends of the building, a few yards apart from it, stood a square stone struc-

ture loop-holed, to serve as a fortress to defend the Hall. These fortresses still are seen. In the spoon commemorating Sir William Johnson and his mansion, the bust, house etc. have been reproduced from illustrations in Lossing's Field Book of the Revolution. As seen in the illustration in the preceding instalment of this series, a bust of the baronet forms the head of the handle; beneath this in bas-relief, are the old hall and the fortresses, while at the handle adjoining the bowl is a lady's glove the string of which forms in script letters the portion of the word, *rsville*, which combined represent Gloversville and the chief industry of that town. Gloversville is situated in the town of Johnstown, about three miles north of the old hall. Ninety per cent. of the gloves made in the United States and large quantities of so-marked imported gloves are the product of the factories in this small town. The outline of the handle of the spoon will be seen to be very original and effective. The workmanship employed in producing the likeness and the details of the structures, etc., is excellent. Altogether this is one of the most artistic and historically significant spoons on the market. It is made in sterling silver only in tea, coffee, and orange shapes. A. D. Norton, Gloversville, N. Y., who designed the spoon, has it on sale.

HOMER'S PLYMOUTH ROCK.

It has already been narrated how the handful of courageous and God-fearing pilgrims landed in 1620, from the Mayflower, at a point on the Massachusetts coast, since known as Plymouth, a name given the spot by the voyagers in memory of the hospitalities they had received at the English town of the same name. A souvenir spoon commemorating this event has already been described. The demand for such a souvenir has been so heavy, owing undoubtedly to the large proportion of the population of the country, who carry Mayflower blood in their veins, as it were, that G. E. Homer, Boston, Mass., has produced a very neat little spoon known as the Plymouth Rock or Landing of the Pilgrims. As seen in the illustration, the hollow of the bowl depicts the landing, five or six men drawing the lighter or life-boat, by means of poles toward the Rock which the event has made famous. The details of the rock are accurately reproduced, while the figures though very minute, partake to as large degree as possible of realism. Under the scene in small letters are the words, Plymouth Rock. On the broad part of the handle is the date, 1620, in old-time figures. The rock, etc., and the date are alone oxidized, which suggests age and produces realistic effect. The spoon is of the same size as the illustration, and is made in sterling silver only. It is a neat and delicate article, its simple ornamentation front and back, suggesting the simplicity of the lives of the people it commemorates.

THE INDEPENDENCE BELL.

First and foremost among the ancient buildings of historic interest which Phila-

delphians preserve with jealous care is Independence Hall, occupying the square upon Chesnut St. between 5th and 6th Sts. It was here that the second Colonial Congress met here that the Declaration of Independence was adopted, and here that the United States Congress assembled, until the seat of the General Government was moved to Washington in 1800. The hall where the Declaration was signed, contains, among other objects of interest, the bell which pealed out freedom to all. Tradition gives a dramatic effect to the announcement of the adoption of the Declaration. It was known to be under consideration, but the closed doors of Congress excluded the populace. They awaited in throngs an appointed signal. In the steeple of the State House was this bell which had been imported from London by the Provincial Assembly of Pennsylvania. It bore the pretentious text from Scripture: "Proclaim liberty throughout all the land with all the inhabitants thereof." A joyous peal from that bell gave notice that the bill had been passed. "It was", says Washington Irving, "the knell of British domination."

It seems that the first idea in designing a souvenir spoon for Philadelphia would embrace this historic bell. And so it has been. The spoon produced by the Gorham Mfg. Co. to represent the Quaker City, shows in the bowl the bell cracked as it now appears, with the motto displayed. The shank of the

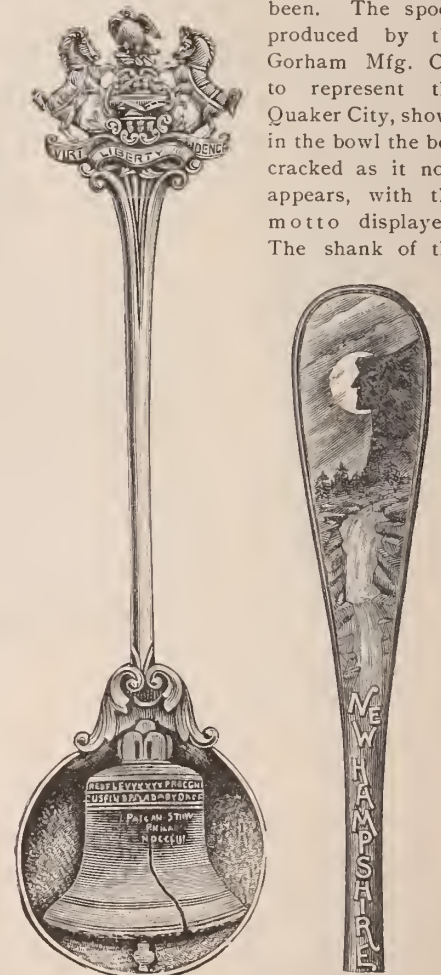

INDEPENDENCE BELL. THE NEW HAMPSHIRE.

handle is of architectural design, terminating in leaves at the bowl and topped with a representation of the coat of arms of Pennsylvania in full relief. The same massiveness, richness and accuracy of workman-

TRADE

SEAMLESS

MARK.

GOLD · FILLED · CHAINS.

ON ACCOUNT OF

THE great popularity of the chains made exclusively by us for the past three years, the air has been FILLED and the paper of the various Jewelers' Journals COVERED with the word "SEAMLESS" which has been and is our trade mark.

We never had such a boom in our business as we have had since our friends commenced to advertise our goods.

We have only a word to add, and that is we make and sell the

ORIGINAL AND GENUINE

SEAMLESS GOLD FILLED CHAINS.

In addition to the word SEAMLESS and for the protection of our customers we place upon each Chain a tag bearing the following trade-mark:



Which is affixed by authority of its owners, as a guarantee that the Chains are made from the Burdon Seamless Filled Wire.

BOSTON OFFICE,

6 WINTER STREET,

In charge of

I. W. STELLE.

NEW YORK OFFICE,

17 Maiden Lane.

PACIFIC COAST AGENCY,

WM. E. PETTES & CO.,

PHELAN BUILDING,

SAN FRANCISCO, CAL.

Address all communications to

KENT & STANLEY,

PROVIDENCE, R. I.

SOLID SILVER

EXCLUSIVELY.



WHITING MFG. Co.

Silversmiths,

UNION SQUARE and 16th STREET,

NEW YORK.

We make solid silver only, and of but one grade—that of Sterling, $\frac{925}{1,000}$ fine; therefore purchasers secure an entire freedom from false impressions, and the question "Is it silver or is it plated?" is never raised concerning a gift bearing the above trade-mark. We have produced the largest variety of special *Souvenir Spoons* for the trade, made by any silversmith.

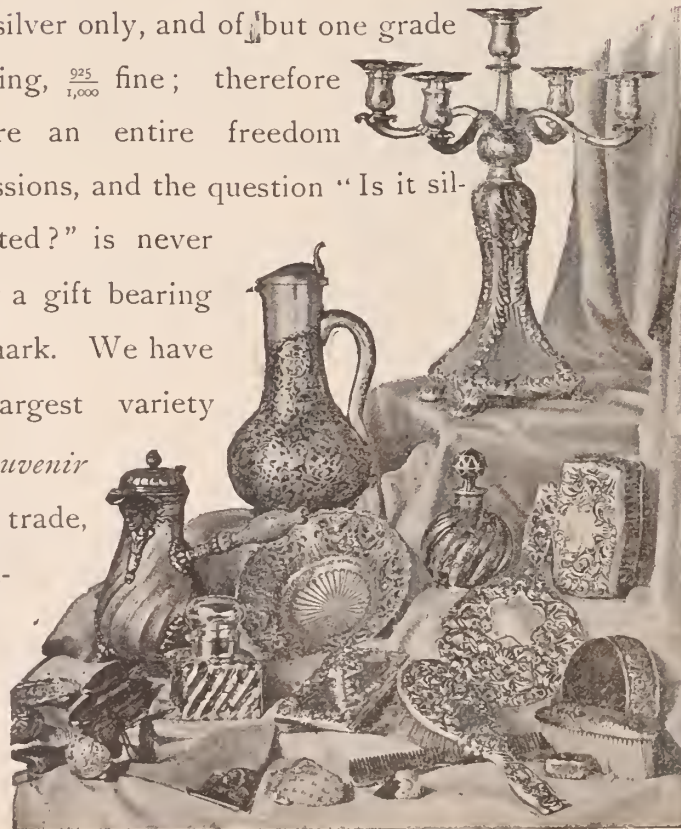

ship characterizes this spoon as in the others of the Gorham Co. already described.

THE WALTHAM.

In Massachusetts there is perhaps no lovelier or more attractive town than Waltham, on the Charles River, a few miles west of Boston. On every hand signs of thrift and prosperity are seen. Though this is so, there would be little to warrant commemoration by a souvenir spoon, if the town was not the seat of one of the largest and most representative industries of the United States, namely the American Waltham Watch factory. This vast industry has so often been described, that to give any details here seems tautological, so to speak. Yet as no one can approach the subject without being tempted to metaphorically pass through the numerous departments of the establishment, the writer, though he

may be charged with redundancy, feels he must give some details. The factory is a vast series of buildings, presenting a frontage of nearly 800 feet, and with wings, towers,



PETER STUYVESANT.

RIP VAN WINKLE.
(HALF SIZE.)

courts and offices. In front of it is an umbrageous park, while the gleaming river is at the back. At the present time the various departments give employment to close onto 3,000 persons; when it is told that the entire population is approximately 20,000, it will be seen that the growth of the town has been dependent chiefly upon that of the watch factory, the steady development of which, during the past thirty years, has been an unremitting source of welfare to the entire population. The output of watches is about 1,900 per day. The factory can claim, perhaps, as many visitors as any industry in the country. It is, therefore, not surprising that, under the above circumstances, some enterprising firm of jewelers should produce a souvenir spoon. This, H. T. Spear & Son, Boston, Mass., have done, their little coffee spoon, illustrated herewith, being as neat and tasteful an article of its kind as has been

THE PAIRPOINT MFG. COMPANY, NEW BEDFORD, MASS.

Fine Gold and Silver Plated Ware.



No. 1249. CAKE BASKET.



No. 2954. FLASK.

CATALOGUES AND PHOTOS TO THE TRADE ON APPLICATION.

NEW YORK.

CHICAGO.

SAN FRANCISCO.

PHILADELPHIA

SOUVENIR SPOONS.

A FINE ASSORTMENT

OF THE

MOST ARTISTIC AND SALABLE DESIGNS.



DAVID F. CONOVER & CO.,

SEND FOR SELECTION.

PHILADELPHIA, PA

produced. Within the bowl is seen the word Waltham, etched in fancifully shaped letters on an oxidized ground. The handle is a delicate twist of bright silver, at the end of which is a miniature of a Waltham watch, the workmanship of the details being excellent. The face of the watch is oxidized. The two oxidized portions enhance greatly the general effect.

JOHNSTON'S NEW RIP VAN WINKLE.

The romantic figure of Rip Van Winkle seems to be never-ending in its attractiveness. Besides the handsome spoons already described, manufactured by J. H. Johnston & Co., New York, and W. B. Durgin, Concord, N. H., the former firm have produced a second Rip Van Winkle spoon, which surpasses the first. The outline of the shank of the massive handle is delicate, though the top is a sort of capital of architectural design upon which stands a miniature of the long sleeper accurately modeled. The clothes of the white bearded old man are in tatters, and with one hand pressing his forehead in a gesture of amazement at his condition and surroundings, and the other grasping his old time-eaten musket, he seems to be crawling along, he knows not whither. Along the shank, the word, New York, in perpendicular artistically shaped letters is seen. The spoon though just placed on the market is meeting with a very heavy sale. It is oxidized and made in coffee and tea sizes.

LOW'S NEW WITCH.

Believing that in the fad of collecting souvenir spoons, the especial demand is for that which is most unique and artistic, Daniel Low, Salem, Mass., the originator of the Witch spoon that has obtained so wide a popularity has produced another Witch spoon, of a very elaborate design, perhaps more elaborate than any spoon on the market. Depicted on the handle are all the features connected with the witchcraft delusion. The handle is composed of the broom of the witch, entwined with the rope in which are stuck the three witch pins. At the lower end of the handle adjoining the bowl, is seen the witch's constant companion, the black cat, very uncanny in pose and gesture. At the head of the spoon is the famous witch herself astride the new moon. She is of the same design as the witch in the first Witch spoon already described and illustrated. One long, lean and lanky arm enfolds one portion of the crescent while the hand of the other arm grasps a broom. She has evidently just finished her trip to the lunar sphere, which tradition says she always took when about to perform some dire, dark and uncanny operation. The reverse of the spoon carries out the idea of the front. The front of the handle contains the name of the town and date of the delusion, Salem, 1692. The workmanship of the details is very fine, and though there are numerous features in the design, and the article is made of heavy weight, the shape of the spoon is such that

it can be conveniently used, the orange spoon with its deep bowl and sharp point, being especially practical. This new Witch is made in tea coffee and orange sizes.

THE CLEOPATRA

About three years ago Mrs. James Brown Potter, a prominent society puppet and lady of fashion, who had performed various romantic roles in an amateur way, to the entire satisfaction of her set and herself, was suddenly inspired with a mission to "elevate the stage," and thereupon entered the lists as a professional actress. After walking through several parts especially written for her, and the stage remaining still unelevated, it was with the impression that it would be a *coup d'etat* or a *coup de guerre* to place upon the stage a grand spectacular production of Shakespeare's Antony and Cleopatra, she herself enacting the role of Egypt's queen. Some time after Sarah Bernhardt, the famous French actress, produced a version of the same play by Sardou, and created a furore in Paris and other cities of the European continent. The success attending this enterprise led minor actresses, as Fanny Davenport, Margaret Mather, Lily Langtry, Marie Prescott and lesser lights to produce their own, individual Cleopatra, having no particular connection with any other Cleopatra; so that when Mme. Bernhardt came to America some months ago, every woman who pretended to taste thought it incumbent upon her to wear something

The R. Wallace & Sons Mfg. Co.,



No. 230 CUP. IN STERLING SILVER, TWO-THIRDS SIZE.

MANUFACTURERS OF

Sterling Silver, Plated Ware & Fine Cutlery

FACTORIES, WALLINGFORD, CONN.

{ New York Store: 3 Park Place.
{ Chicago Store: 104 State Street.

SOUVENIR SPOONS.



In answer to the fashion for such mementos, we have produced a large variety of unique and peculiar spoons, suggesting cities and events. The accompanying cuts represent the various paths through emblematic cities are sold generally. Besides the patterns illustrated here, we have designs applicable to almost every large city in the

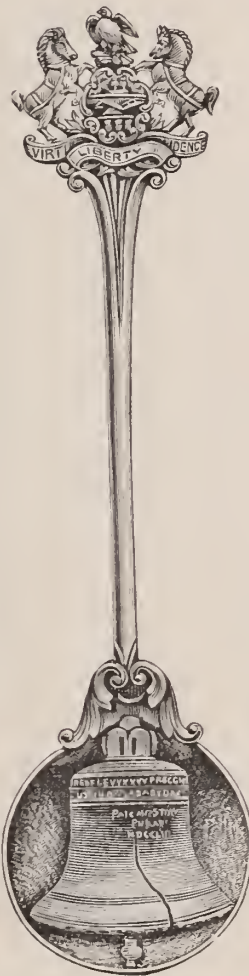

have produced a unique and peculiar spoon, suggesting cities and events. The accompanying cuts represent a few of the patterns, which are applicable to certain cities and events. Besides the patterns illustrated here, we have designs applicable to almost every large city in the



GORHAM MFG. CO.

Silversmiths,

Broadway and 19th St., New York

suggestive of the oriental queen. The manufacture of jewelry especially, was affected, numerous designs being produced that contained some suggestion of Cleopatra. The Cleopatra spoon, designed and manufactured by the Alvin Mfg. Co., 860 Broadway, New York, is therefore in line with this fashion, and will undoubtedly have a large sale. At the top of the handle is a miniature head of the famous French actress, adorned as she appears in the play. The likeness is perfect, and in the fine electro deposit style of work for which the Alvin Co. have become celebrated; the head is very realistic, the details of hair and the like being minutely reproduced. The shank of the handle represents a column in Egyptian style, topped by a capital of conventional Egyptian leaves. About the shank twine two asps, which seem to be the accepted suggestion of the fiery queen.



NEAL DOW.

GEORGE WASHINGTON.

The Cleopatra is made in tea, coffee and orange sizes.

THE NEW HAMPSHIRE.

The grand and beautiful scenery of the White Mountains in New Hampshire, and their wonderful cascades, precipices, ravines, lakes and forests, annually attract many thousands of visitors from all parts of the United States and Europe, and have gained for this elevated region the name of "The Switzerland of America." Among the dis-

tinguished peaks is Profile Mountain, which resembles the profile of an old man grinning. The features are sharp and well-defined, and the face seems to project from the side of the mountain. In the spoon which W. B. Durgin, Concord, N. H., has produced as a souvenir of New Hampshire, this peak is seen in the handle, with the beautiful surrounding landscape, consisting of cascades, shrubbery, firs, etc. The new moon and clouds are seen behind the mountain, the face seeming to look into the hollow of the moon. Below the landscape, on the remainder of the shank, are the words New Hampshire, in raised perpendicular letters. The die is a very fine one, the reproduction of the view being perfect. The front of the handle is oxidized, the remainder of the spoon being plain. The spoon is made in tea, coffee, orange and sugar sizes.

Of the Peter Stuyvesant, Neal Dow, George Washington, Grant and Lincoln, illustrated here, descriptions were given in previous instalments of this series.

(To be continued.)

A Decision Against Payne, Steck & Co.

After being three days in Court, the suit of W. S. Hedges & Co., 170 Broadway, New York, against the defunct firm of Payne, Steck & Co., who failed three years ago, resulted in a victory for the plaintiff.

When the defendants confessed several judgments in Dec., 1888, the New York trade received a shock that had not been equaled in years. The liabilities of the firm exceeded \$100,000, and when, two days after the sheriff had been in charge of their office, the safe was opened and found to be empty, the indignation among Maiden Lane importers was beyond measure. Among the many creditors of the firm were W. S. Hedges & Co., and the suit just decided was to recover \$1,246, the value of diamonds obtained by W. H. Payne a few days before the failure. The hearing of the evidence was begun on Wednesday, and the case was not closed until Friday afternoon.

From the testimony it appears that on Dec. 13, 1888, W. H. Payne obtained from the plaintiffs, on memorandum, a pair of earrings worth \$845 and ten days later secured another pair valued at \$500. On the 28th he confessed several judgments to his wife and other relatives, and neither the money nor the diamonds ever reached Hedges & Co. A demand was made for the return of the goods by a representative of the firm, and after the failure Payne made an appointment in New York, with W. N. Post, a salesman of Hedges & Co., to settle the matter, but he never appeared. When the few assets of the bankrupt firm were sold by the sheriff, the diamonds were not among them, and it was charged that Payne had fraudulently disposed of them before confessing judgments.

Among the witnesses called was janitor Whitely, of the building 177 Broadway, where the office of Payne, Steck & Co. was located, who testified that, on Dec. 26, 1888, which

was observed as a holiday owing to Christmas falling on Sunday, he saw W. H. Payne in the office, with the safe open and a quantity of jewelry on the counter before him. He remained in the place from 10 o'clock to 3 o'clock, and when he left he carried a small valise with him. The defendant's lawyer endeavored to show that three other men were with Payne in the office during the day, and that they were only examining the books, but none of these men were produced as witnesses. Leopold Stern, of Stern Bros. & Co., J. F. Saunders, and W. H. Vogel, of Alfred H. Smith & Co., all testified to dealings they had had with W. H. Payne, and also as to the trade use of memorandum forms.

During the trial W. H. Payne sat in court near his lawyers, and continually held whispering consultations with them. The defence depended on Payne as their principal witness, and when on the stand he answered all questions in a ready and apparently straightforward manner. His testimony, however, was in several instances in direct variance to that of the plaintiff witnesses. When the jury were asked for their verdict, the foreman answered "for the plaintiff unanimous on the first ballot," and a judgment was given accordingly. Under this judgment the defendant can be arrested and held in jail for payment.

Anderson & Howland were the attorneys for the plaintiffs and J. Lyng for the defendant.

The Jewelers' League.

At the regular meeting of the Executive Committee of the Jewelers' League, held on Friday evening, April 3d, there were present President Hayes, Vice-President Greason and Messrs. Jenks, Jeannot, Sexton and Howe.

Eleven requests for change of beneficiary were granted; two applications were rejected; one application was referred for investigation and the following applicants were accepted as members: V. L. Burgesser, Newark, N. J., recommended by J. M. Bennett and J. R. Greason; C. W. Eberhardt, Cleveland, O., by P. L. Miles; H. Leon, Chicago, Ill., by E. H. Goodrich; A. W. Reineman, McKeesport, Pa., by J. O. Slemmons; F. S. Taggart, Toronto, Can., by J. Duplain; A. West, Manitou Springs, Col., by F. G. Thearle, Jr., and C. H. Knights, and R. H. Wimans, Chicago, Ill., by Lloyd Milnor.

The next meeting of the Executive Committee will be held on Friday, May 1st.

Peter Burshe, New Haven, Conn., is to close his business in a week or two, and sail for Europe about May 1st on the steamer *Spree*. He was for thirteen years head watchmaker and repairer at G. H. Ford's, and for about an equal period has been in business for himself. He will spend about a year in Europe, traveling in France, Germany, Switzerland and Austria, returning to New Haven afterward.

“THE PLYMOUTH ROCK SPOON.”



PATENT APPLIED FOR.

No collection of Souvenir Spoons complete without one from Old Pilgrim Plymouth.

THE SPOON has on the handle in raised figure, an exact fac-simile of the world-famous Rock on which our fore-fathers landed in 1620.

MADE IN

Orange, Sugar, Tea and Coffee Sizes,
IN STERLING SILVER ONLY.

SOLD ONLY BY

GOODING BROS.,

PLYMOUTH, MASS

Write for Prices.

JAMES P. SNOW.

ESTABLISHED 1834.

CHAS. E. WESTCOTT

SNOW & WESTCOTT,

SUCCESSORS TO G. & S. OWEN & CO.
MAKERS OF

FINE JEWELRY,

Lace Pins, Ear Rings, Scarf Pins, Sleeve Buttons, Sash Pins, Collar Buttons, Bracelets, Studs.

All Goods sold by us are exclusively of our own manufacture and are warranted 14 K. Fine, and stamped as such when possible.

No. 3 MAIDEN LANE, NEW YORK.

ESTABLISHED 1865.
N. J. FELIX,
MANUFACTURER OF
GOLD AND SILVER WATCH CASES,
ROOMS 6, 7 AND 8,
71 Nassau Street, N. Y. City.
REPAIRING CASES (no matter how badly damaged) A SPECIALTY.

BEECHER & CLARK,



Designs and Estimates Furnished on Application.

352 JEFFERSON STREET,

Guthrie Block, LOUISVILLE, KY.

ALVIN MFG. CO.,

SILVERSMITHS,

860 Broadway, New York.

206 Kearney St., San Francisco.

Factory, NEWARK, N. J.

DAY & CLARK,

MAKERS OF

FINE JEWELRY,

BEAD NECKS AND BEAD BRACELETS

CURB AND LINK BRACELETS
STRICTLY 14 KT.

10 MAIDEN LANE. N. Y.

WILLIAM B. DURGIN,

Designer and Maker of Wares in STERLING SILVER,

CONCORD, NEW HAMPSHIRE,

Cautions Manufacturers against infringement of Orange Spoon Bowl, as shown in accompanying cut, as it is fully protected by Letters-Patent.



MANUFACTURER OF FINEST LINE OF ORANGE SPOONS ON THE MARKET.

BY SPECIAL ARRANGEMENT, CERTAIN PROPRIETORS OF SOUVENIR SPOONS ARE PERMITTED TO USE THIS BOWL.

MAKER OF PAUL REVERE, NEW HAMPSHIRE AND PRISCILLA SOUVENIR SPOONS

THE BOWDEN Seamless Plain Ring,

IS MADE ONLY BY
J. B. BOWDEN & CO.,

Makers of FINGER RINGS of
every Description,

COR. BROADWAY & JOHN STREET,
NEW YORK.

TOWLE MFG. CO.,

MANUFACTURERS OF



Sterling Silverware



NEWBURYPORT, MASS.: 214 MERRIMACK ST.

CHICAGO:

149 & 151 STATE ST.

SAN FRANCISCO:

220 SUTTER ST.

BIRTHDAY * RINGS!

IN order to meet the increasing demand for BIRTHDAY RINGS, we have originated and Patented an attractive novelty in the shape of an elegant tray, containing of assorted patterns, 48 Rings, four for each month, with appropriate stones and the sentiments thereof, printed upon the tray in gilt letters.

As the whole four dozen cost but a very moderate amount while we make no charge for the tray, which is of velvet and satin, as handsome as can be made, and the Rings it contains are of our latest and most desirable styles, we think that every Retailer will find it for both his interest and convenience to order this tray from us

M. B. BRYANT & CO.,

* * RING MAKERS, * *

10 MAIDEN LANE,

NEW YORK.

THE "BRYANT" INITIAL RING, easily interchangeable, still keeps the lead as the best made—SIMPLE, STRONG and HANDSOME—in trays of 6 or 12, with separate initials.

Imports and Exports for February, 1891.

WASHINGTON, D. C., April 8.—The summary statement of imports and exports of the United States for the month ending February 28, 1891, and for the eight months ending the same day, compared with the corresponding periods of last year, issued to-day, shows the following figures relative to the jewelry trade: imports, diamonds and other precious stones, rough and uncut, including glaziers' and engravers' diamonds not set, and jewels to be used in the manufacture of watches, month of February, \$55,633 against \$8,226, in 1890, a gain of \$47,407, and a loss from January of \$7,180; for the eight months, \$511,906 against \$96,278, a gain of \$415,628; clocks and parts of, \$9,260 against \$16,368, a loss of \$7,108 and a gain of \$4,988 over January; for eight months, \$254,789 against \$345,260, a loss of \$90,471; watches and parts of, etc., \$196,228 against \$112,810, a gain of \$83,418, and a gain over January of \$70,738; for the eight months, \$1,432,452 against \$1,114,834, a gain of \$317,618; jewelry and manufactures of gold and silver, \$123,457 against \$142,171, a loss of \$19,714, and a loss from January of \$17,046; for the eight months \$1,061,683 against \$939,390, a gain of \$122,293; precious and imitation stones, not set, \$747,125 against \$897,132, a loss of \$150,005 and a gain over January of \$78,706; for the eight months, \$8,142,127 against \$7,994,144, a gain of \$147,983; bronze manufactures \$49,444 against \$74,236, a loss of \$24,792, and a gain over January of \$5,145; for the eight months, \$539,985 against \$615,333.

Exports of domestic merchandise, clocks, etc., \$100,806 against \$91,673, a gain of \$9,133, and a gain over January of \$9,131; for the eight months, \$861,498 against \$880,603, a loss of \$19,105; watches, etc., \$12,288 against \$17,080, a loss of \$4,792, and a loss from January of \$5,697; for the eight months, \$181,343 against \$254,095, a loss of \$72,752; jewelry, etc., \$56,420 against \$79,647, a loss of \$23,227, and a loss from January of \$11,586; for the eight months, \$575,183 against \$424,150, a gain of \$121,033; plated ware, \$34,480 against \$32,715, a gain of \$1,765, and a gain over January of \$4,376; for the eight months, \$281,279 against \$313,156, a loss of \$31,877.

Exports of foreign merchandise, clocks, etc., for the eight months, \$11 against \$147; watches, etc., \$20 against \$58, nothing in January; for the eight months, \$5,295 against \$1,018, a gain of \$4,277; jewelry, \$298 against nothing, and a loss of \$6,822 from January; for the eight months, \$11,815 against \$4,078, a gain of \$7,737; precious stones, etc., \$6,000, against \$12,128, a loss of \$6,128, and a loss of \$11,152 from January; for the eight months, \$27,978 against \$63,971, a loss of \$35,993.

The table of imports during eight months, ending February 28, 1891, as compared with the average of the same periods of the five preceding years, shows the following: clocks and watches, etc., increase \$377,173; jewelry, etc., increase \$1,725,412. In exports, clocks increase \$97,049.

A New Watch Club System.

NEWARK, N. J., April 8.—The Chicago Watch and Jewelry Co., an account of whose alleged illegal proceedings in this city was published in a recent issue of THE CIRCULAR, have adopted a new system in their business. Instead of having a drawing as heretofore to determine the winner of a watch in each club, a ballot is now furnished to each member, with a request to write one number from 1 to 38 inclusive upon it. The member is then given his number and in nine cases out of ten will vote for himself.

A few votes for one member will of course win the watch. This has been found out by a number of young men, who have formed a "combination." Nine employes of the Cahoon Barnett Co., entered the club a few days ago; when the votes were counted a CIRCULAR reporter was told that one Joseph Morris had been elected a winner. Morris is one of the nine. It is probable that another of the "combination" will receive a watch next week, as the nine men will hold together until each has a watch.

When manager A. Ford was spoken to about this case by THE CIRCULAR reporter he seemed displeased that so much was known, but confidently said that he would prevent it in the future, which is, however, impossible. When asked what was done when but thirty-two or thirty-three members were obtained for one club, Mr. Ford said that the company then made up the deficiency by putting in blank ballots. He was then asked whether the company could afford to do this very often, as each blank means \$1 less of profits on each club; Mr. Ford had no answer to this. He also said that his concern intend to do business in Newark until "They are ridden out of town".

Dan Beatty, successor to Henry Ross, Montreal, P. Q., recently resurrected a small sample case which is two or three centuries old, judging by the specimens of workmanship. The samples consisted of watch hands. Mr. Beatty will use them in repairing clocks.

The Galveston Watchmaker Under Police Surveillance.

GALVESTON, Tex., April 8.—The cracksmen, J. B. Curry, alias Saunders, who was arrested a few days ago while working as a watchmaker, is still in town under police surveillance. He is undecided what to do or where to go. He is without money, and while a good watchmaker and willing to work honestly at his trade, he says he could not expect any reputable man to give him employment after the publication of the El Dorado affair.

Despite Curry's cautiousness the following facts have been gleaned of his career: In the past four years he was arrested in Los Angeles, Cal., during the boom there, for a trick of \$2,200, and after a detention of twenty days, was set at liberty. He was arrested in Kansas City, Mo., Sept. 25, 1890, with \$5,000 worth of diamonds, which he sent another man after to the express office, and when taken before Chief of Police Speers said his name was J. P. King. Speers turned him over to Pat O'Keefe, chief detective of the Chicago and St. Paul Railway Co., for an express thievery done in Austin, Minn., where a lot of good money was taken. The express officials not being able to identify Curry he was held one day in Austin and then taken to St. Paul, where there was a sheriff from Iowa, Illinois and Wisconsin, each with requisitions for him for some crime committed in their respective States, but, being unable to identify him, Curry was turned loose. He has been in the clutches of Pinkerton's men, who failed in making a case against him. He was also arrested in other parts of the country, but will not disclose where, and is also wanted in other parts.

He first came to Galveston last April under the name of W. B. Miles and worked in Migel's pawnshop at his trade, where he was employed when recently arrested, and while here was approached to do a job, but declined and soon after left and went to Kerns, Tex. After remaining there a short time he went to Minnesota.



"THE CENTENNIAL"

LEADS THEM ALL.

Acknowledged by all dealers to be the best Chronograph in the Market. Made also as a Plain Timer.

Ask your jobber for them, or order of the Manufacturers,

CROSS & BEGUELIN,

21 Maiden Lane, N. Y.,

IMPORTERS OF

DIAMONDS, WATCH MATERIAL, OPERA GLASSES, Etc., Etc.

Jobbers of all grades of American Watches, Gold and Rolled Plate Jewelry.

SEND FOR PRICE LIST.

MATHEY BROS., MATHEZ & CO.

16 MAIDEN LANE, N.Y., AND BRASSUS, SWITZERLAND,

MANUFACTURERS AND IMPORTERS OF

Plain and Non-Magnetic Movements.

Complicated Watches a Specialty.

**CHRONOGRAPHS,
MINUTE REPEATERS,
AND
SPLIT SECONDS,**

IN ALL GRADES AND SIZES.

SOLE AGENTS FOR

H. L. Matile, C. H. Meylan and J. J. Badollet. Watches Demagnetized.



REPEATERS



CHRONOGRAPHS.

"THE SIR WM. JOHNSON SPOON."



One of the most Artistic and Historic Souvenir Spoons now on the market.

THE spoon has on handle the bust of Sir Wm. Johnson, and in bas-relief, the old Sir Wm. Johnson Hall and Forts; still further down a Ladies Glove and the word *rsville*, representing Gloversville, and the chief industry of the town.

MADE IN Tea, Coffee, Orange Spoons, in Sterling Silver only.

Send for price list.

For sale by

A. D. NORTON,
GLOVERSVILLE,
NEW YORK.

JEANNOT & SHIEBLER

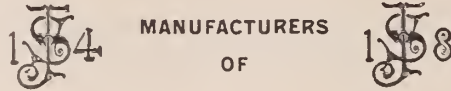

MANUFACTURERS OF

Fine Gold Watch Cases.

No. 20 MAIDEN LANE,
New York.

Constantly on hand, 14k. and 18k. Cases to fit any Movements in the Market.

GEO. W. SHIEBLER,
SILVERSMITH.



Artistic Novelties.

HOLLOW AND FLAT WARE.

Sterling Silver

No. 8 Liberty Place,
NEW YORK.

N. KOCH.

L. DREYFUS.

J. KOCH.

I. PFORZHEIMER.

KOCH & DREYFUS,

22 John Street, New York.

IMPORTERS OF DIAMONDS,

JOBBERS OF

AMERICAN WATCHES,
Diamond Novelties and Jewelry

We have now a complete line of Goods and Specialties on hand and on the road in charge of following representatives:

JONAS KOCH, GEO. MALLET, L. GOLDSMITH,
HENRY HEYMAN, A. ROSENTHAL.

ESTABLISHED 1837.
GEO. O. STREET & SONS,
MAKERS OF

Fine Rings, Locketts, Seals, Sleeve Buttons and Links,

15 John Street, - NEW YORK.

WOOD & HUGHES,
Sterling Silverware Manufacturers.

New York Agents for the Derby Silver Co.'s
FINE QUADRUPLED PLATED WARE.
No. 16 JOHN STREET, - NEW YORK.
206 Kearney St., San Francisco, Cal.
HASKELL & MUEGGE, Agents.

OSTBY & BARTON,

SOLID GOLD BAND, STONE
- - AND FANCY RINGS - -



* - - ALSO A LARGE LINE OF EMBLEM RINGS. - - *



EASTER AND ITS CROP OF NOVELTIES—THE METALIZING OF FRAGILE SUBSTANCES.

PARIS, France, April 4.—During the *Semaine Sainte*, Parisian ladies lock away their jewels. One would believe that they give up, forever, all idea of enhancing their personal attractions with the help of gold and precious stones. Happily it is not so. As soon as society is allowed to exchange fasting for festivities, diamonds, pearls, rubies, emeralds, sapphires, etc., escape from their satin or velvet prisons.

Easter presents have not for many years offered much variety. Paper weights this year exhibited a hen surrounded with her chicks earnestly engaged in pecking; ladies' *necessaires* and jewel-cases were in the shape of an egg in frosted gold or silver, etc. Our aristocratic places seldom keep these articles.

In some shops I have noticed bonbon boxes, round, oval or square-shaped, of plain or engraved crystal, covered with chased gold ornaments which exhibit here and there vari-colored stones.

An original fashion among gentlemen consists in wearing, on the left end of a tie, a fly made of precious stones, either diamonds, rubies, emeralds or sapphires, in accordance with the color of the tie.

Cigar-holders in amber are decorated in many different ways, some being wrapped with a pierced oxidized silver foliage, some encased in a gold trellis encrusted with brilliants, while several exhibit a snake entwining the amber, or two frosted silver mice playing with each other.

In a jewelry display I noticed at the Palais Royal, a gold lizard, with parallel lines in green enamel, darting across a diamond crescent. The tail of the familiar reptile was curled in a kind of ziz-zag style, which was quite realistic.

An earring consisting of a bird (made of stones harmoniously arranged in point of color) hanging from a pearl which he holds in his beak, is at once pretty and original.

At a well-known place, I have remarked a handsome necklace showing a row of round black pearls between two rows of diamonds. The pendant consisted of two pear-shaped black pearls, of a large size, hanging from cords of different lengths made of brilliants.

Various attempts have for some time been made to metalize fragile substances. I have seen some pretty sets of jewelry, apparently in enameled metal partly gilt or silvered, which are claimed to be made of a kind of porcelain, coated by an electric process, with plumbago and platina, and subsequently plated with gold or silver. These jewels are partly enameled.

ESTABLISHED 50 YEARS.

RANDEL, BAREMORE & BILLINGS,

IMPORTERS OF

DIAMONDS,

AND OTHER PRECIOUS STONES.

FINE PEARLS A SPECIALTY.

MANUFACTURERS OF

DIAMOND JEWELRY,

IN THE LATEST DESIGNS.

Diamonds Recut in Modern Styles or Repaired on Premises.

58 Nassau Street,
29 Maiden Lane,
NEW YORK.

1 Tulp Straat,
AMSTERDAM

1 St. Andrews St.,
Holborn Circus,
LONDON, E. C.

LARTER, ELCOX & CO.

MANUFACTURERS OF

THE SPRING BACK STUD.



Send for Selection Package of Studs.

SNAKE RINGS.

GENTLEMEN'S

WHITE · ONYX · JEWELRY.

LADIES' RINGS.

Gentlemen's Rings.

FACTORY, NEWARK, N. J. + + OFFICE, 41 & 43 MAIDEN LANE, N. Y.

CHARLES H. PECKHAM,

DIAMONDS AND DIAMOND JEWELRY,

63 NASSAU STREET,

Goods Sent on Memorandum.

NEW YORK.

FACTORY,
ST. IMIER, SUISSE.

HIPP DIDISHEIM,

83 NASSAU STREET,
NEW YORK.

IMPORTER OF WATCHES,

SPECIALTIES:

The "Nassau," the best imported movement in the market, fitting all American cases.
The "Mignon," the best Chatelaine Watch for the money.
The "Gem," a high grade Chatelaine Watch with second hand, gold crown jewels in extra settings, etc.

If your jobber don't keep these goods, send to us and we will send you the address of one who does.

REMOVAL.**R. A. BREIDENBACH,**

IMPORTER OF

DIAMONDS

PRECIOUS AND IMITATION STONES,

IS NOW LOCATED AT

51 & 53 MAIDEN LANE.

Largest line of Stones of every description.

NEW GOODS—STERLING SILVER.**Spring Novelties.****Lewis Brothers,**

41 Maiden Lane, New York.

NICHOLSON FILE COMPANY,
Offices at Providence, R. I.**FILES—Extra { TRADE MARK. } Fine—RASPS**Works at Providence, R. I. } —FOR— JEWELERS, } Works at Pawtucket, R. I.
WATCHMAKERS, TOOLMAKERS, Etc.**WATCHMAKING SCHOOL.**

Have your Young Men become No. 1 Artisans by sending them to

R. Jaegerman's Watchmaking School.

For particulars, write to

R. JAEGERMAN, Manager,

No. 622 Locust St., ST. LOUIS, MO.

Arrested for Receiving Stolen Goods.

CINCINNATI, O., April 8. —P. Mincowsky, proprietor of a jewelry store on 6th and Vine Sts., was arrested on Friday for receiving stolen goods. The warrant was sworn out by Sebastian Buerkle, a butcher residing in Batavia, this State. Buerkle says that on March 17 he employed Julius Beyer to work about the shop. Several days afterward Beyer disappeared, and with him a valuable gold watch. Last Monday Beyer returned to Batavia and was arrested for grand larceny. He waived examination and was bound over.

In the mean time Buerkle heard that his watch had been sold in this city. On Friday he came here and found the watch in Mr. Mincowsky's possession, but the latter refused to give it up unless he received the amount he had paid Beyer for it. Buerkle then swore out a writ of replevin for the time-piece before Squire Gass, but the constable was unable to find it. As Mincowsky positively refused to give up the watch, Buerkle had him arrested for receiving stolen goods. He was given a preliminary hearing by Squire Gass, and released on \$300 bond for his appearance the following Thursday.

The Pins Did Not Suit Him.

About 12 o'clock on Tuesday of last week, a tall, powerfully built man, entered the store of G. W. Welsh's Son, at 235 Greenwich St., New York, and asked salesman Gustave Pelloth to show him some diamond pins. A tray was placed before him, and was left on

the counter while the salesman turned to get another lot. The man said he saw no pin to suit him, and was about to leave, when Pelloth discovered that three pins were missing from the tray, and had the man arrested.

At the police station the prisoner gave his name as T. H. Moss, and said he lived at Orange, N. J. While on the way to police headquarters to be photographed, Moss made an unexpected attack on the two policemen who escorted him, but was subdued by a few blows of the club. The next day on being arraigned in the Tombs he pleaded that he was drunk, and did not know what he was doing in the jewelry store. An officer stated that several other complaints had been received against him, and he was held for trial without bail.

Chester's Burglars Sentenced.

CHESTER, Pa., April 8.—Henry, alias "Bull" Lowry, the Philadelphia crook, convicted at the March Quarter Sessions Court of breaking into Hubert Muller's store in this city on Christmas Eve last, and making off with a large quantity of watches, was sentenced at Media, yesterday, to \$100 fine and costs and three years in the Eastern Penitentiary.

George Harris, the fair-haired protege in Lowry's school of thieves, and who is but nineteen years of age, was sent to the Reformatory school at Huntingdon. Sentence of the men had been postponed, in order that the Court might learn their criminal records.

A GREAT CONVENIENCE FOR

 **Clock Dealers and Repairers.** 

We have now a complete stock of Wheels, Pinions, Hands, Dials and all loose pieces for French and English movements. Also single movements with or without dials.

Our stock of imported clocks comprises Chiming and Hall Clocks, Sèvres and Faience, Vernis Martin, Gilt Bronze, Crystal with Mercurial Pendulum, Carriage Clocks in endless variety of styles and combinations, Marble and Onyx Clocks of the best selling designs, Coaching and Desk Watches, Regulators, etc.

NEW GOODS ARRIVING EVERY WEEK.

Apply for our Catalogue, or inspect our stock to compare our prices.

CHARLES JACQUES & CO.,**2 MAIDEN LANE, NEW YORK.**

News Gleanings.

H. Hiffman, Staunton, Ill., died recently.
 Jacob Streamer, Pontiac, Ill., died recently.
 C. C. Williams, Middleport, Ohio, has assigned.
 F. B. Johnson, Mariette, Wis., is out of business.
 P. Sugar, Baird, Tex., has gone out of business.
 W. A. Webster, Sidell, Ill., has gone out of business.
 G. E. Veeder & Co., Paullina, Ia., are out of business.
 J. M. Steller is no longer located at Three Oaks, Mich.
 J. A. Platte is out of business at Ashburnham, Mass.
 H. J. Bentley, Waukon, Ia., has sold out to Palmer & Rush.
 Jacobs & Pincus have succeeded A. Pincus at Butte City, Mon.
 J. P. Hoff has moved from Grover Hill, O., to Scott, same State.
 F. A. Schleuder has succeeded Schleuder & Retsloff, Decorah, Ia.
 F. S. Ladd has started in business at Thompsonville, Conn.
 M. S. Pershall has moved from Urbana, O., to Lima, same State.
 A. B. Cherry, Jr., has moved from Miller, Neb., to Silverton, Ore.
 Philip Paultrowitch will shortly open a store at Marionville, Pa.
 James Leslie has moved from Iowa Falls, Ia., to Daws, same State.
 O. J. Cole, Elmore, Minn., died recently and his business is closed.
 J. M. Heaton, Clearfield, Pa., on May 1 will move to a new location.
 The Wellsville Jewelry Co. have succeeded W. D. Wade at Wellsville, O.
 J. W. Squires, Marine City, Mich., has sold out his jewelry business.
 I. H. Roberts has moved from Maryland, N. Y., to Oneonta, same State.
 Louis Bilfils has moved from Grant's Pass, Ore., to Rosebury, same State.
 W. B. Moore & Co., Yorkville, S. C., have sold out to T. W. Clawson & Son.
 Henry Beisenheimer has moved from Livermore, Cal., to Mayfield, same State.
 E. B. Woodward, Wapheton, N. Dak., has been succeeded by E. B. Woodward & Co.
 C. E. Ritchie, Grand Rapids, Mich., recently moved from 606 to 152 S. Division St.
 A. E. Waterbury, formerly in business in Polo, Ill., is now located in Traverse City, Mich.
 D. Herman & Bro., Elmira, N. Y., have just put in position an elegant new show case.
 W. H. Cooper, recently of Louisville, Ky., has started in business at Leitchfield, same State.

USE THE 
AMERICAN MAINSPRINGS
 FOR ALL KINDS OF AMERICAN WATCHES.
 [FACSIMILE OF WRAPPER.]

1 DOZ. MAINSPRINGS
18 S. E. O. S. 
 Extra Quality.
 TRADE  MARK.

THE BEST IN THE MARKET.

L. H. KELLER & CO.,
 Dealers in Fine Watch Materials and Tools.
 AGENTS FOR THE PATEK, PHILIPPE & CO. WATCHES.
 64 NASSAU STREET, NEW YORK.



John A. Riley & Sloan Co.

860 Broadway, New York.

MAKERS OF

HAIR PINS, HAT PINS,
 TIARAS, BROOCHES,
 SCARF PINS, NECKLACES, ETC.
 Rosaries & Crucifixes, Chatelaines.

Our line includes both 14k. Gold and Sterling Silver.



407



348



408



405



409



397-91



404



244

EXAMPLES OF CLASS PINS (PLATE 26, COPYRIGHT- 1891), DESIGNED AND MADE BY HENRY C. HASKELL, 11 JOHN ST., NEW YORK. PLATES SENT TO DEALERS UPON REQUEST.

"THE BEST." THE Dueber Watch Case.

GENERAL OFFICE,

THE DUEBER WATCH CASE MFG. CO.

CANTON, OHIO, March 1, 1891.

TO THE TRADE:

This Company has been reorganized and all heretofore existing difficulties adjusted. We are now ready for business and respectfully solicit your trade, as all obstacles which heretofore retarded our progress have been successfully removed.

As we desire to increase our Jobbers' list, we solicit correspondence from responsible houses in cities where we now have no Jobbing representatives.

In order to better serve all our customers with promptness and dispatch, we shall discontinue our New York, Boston and Chicago Offices and ship all goods from our Canton (Ohio) Office.

Our Offices in the above cities are for rent and fixtures for sale.

Address all communications to

THE DUEBER WATCH CASE MFG. CO.,
CANTON, OHIO.

J. C. Worst, Meadville, Pa., is moving from the Phoenix Block to the Dreutlein Block.

J. A. James, formerly a jeweler at Woodstown, N. J., has recommenced business at that place.

Charles Castle has moved from Titusville, Pa., to Buffalo, N. Y., where he will open a jewelry store.

W. H. Barrett, Lynn, Mass., is advertising his lease and fixtures for sale. He will auction off his stock.

J. J. Carroll, the musical instrument dealer, of 711 Fulton St., Brooklyn, N. Y., has given a bill of sale to A. Pfister for \$297.

C. F. Billau, Cedar Rapids, Ia., last week closed a successful auction sale of one week. Nearly two hundred watches were sold.

At Helena, Ark., a young man who has several aliases, among them Sinclair, was arrested last week for attempting a forgery on W. L. Kelly.

A. C. Gradolph, Petersburg, Mich., is out of the jewelry business. H. C. McLacklin, of the same town, has been succeeded by G. McLacklin & Co.

August Becker, Jr., Baltimore, Md., was last week united in marriage to Miss Erna Von der Wettern. A largely-attended reception was held after the ceremony.

Jeweler W. W. Francis, Ardmore, Pa., has offered a silver ornamented base ball bat to the winners of the college championship among the classes of Haverford College.

C. W. Freeman's new store, Penn Ave. and Spruce St., Scranton, Pa., was last week opened for business. It is a very attractive bazar, suggesting oriental magnificence.

E. C. Wilson who passed a bogus check for \$100 on R. Bertchy, Memphis, Tenn., some days ago, was arrested last week at Helena, Ark., and brought back to the former city.

The Artistic Jewellery Co., 1105 16th St., Denver, Col., had a souvenir opening on Saturday of last week. The local journals spoke of the opening as the society event of the week.

A. K. Hawkes, manufacturer of eye-glasses, Atlanta, Ga., has moved his office and sales-room to 12 Whitehall St., while at 19 Decatur St. a factory has been started for the production of all kinds of compound and plain lenses.

An electric clock enterprise has been proposed at Waltham, Mass. D. D. Palmer, proprietor of the Waltham School of Horology will be superintendent of the scientific department, while the clocks will be made at factory of John Stark.

Governor Campbell, of Ohio, last week authorized the extradition of G. B. Williams, who is wanted to answer the charge of burglary of the store of J. F. Schmitt, Homestead, Pa., when \$4,000 worth of watches, gold rings, etc., was taken. He had three accomplices. Williams has been under arrest at Jefferson, O.

A. J. GROENMAN & CO.,
DIAMOND CUTTERS,
80 NASSAU ST., N. Y.
WE MAKE A SPECIALTY OF SELLING FINE, SMALL MELEES.

T. B. BYNNER,
Dealer in
Diamonds, Opals, Pearls,
AND EVERY VARIETY OF PRECIOUS STONES,
in varied and novel combinations.
177 BROADWAY, NEW YORK.

ELGIN HOROLOGICAL SCHOOL
ELGIN, ILL.

SEND FOR CIRCULAR.

Repairing for the trade.

Repair price list free.

BOOK * MARKS
IN
STERLING SILVER,

FRANK H. LA PIERRE,
No. 18 East 14th St., New York.

H. M. SMITH & CO.,
MANUFACTURERS OF
Gold Pens and Pencil Cases,

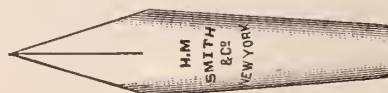

JOBBERS IN AMERICAN WATCHES.
PLATED CHAINS.

Agents for Paul E. Wirt's Fountain Pen.

83 Nassau Street, New York City.

G. F. Johnson, Aurora, Ill., has gone out of business.

Levi Jacobfsky has opened a store at Port Byron, N. Y.

John Hogan has started in business at Hopkinton, Mass.

A. N. Hilfman, Iowa City, Ia., has taken up his new quarters.

A. E. Kauffman will shortly open a store at Boiling Springs, Pa.

Fire at Fennville, Mich., burnt out the store of jeweler Huesen.

John Reitschey has opened a store at 245 1/2 W. King St., Lancaster, Pa.

H. J. Locke, Belfast, Me., has introduced Observatory time in his store.

William Butters has moved from Presque Isle, Me., to Corinna, same State.

The business of Miller Bros., 1st and Market Sts., Louisville, Ky., is closed.

A new firm, Nudd & Tyler, will soon open business at Amesbury, Mass.

C. R. Griffin has started in the jewelry business at North Bellingham, Mass.

G. A. Drew, Lewiston, Me., has moved to a new location at 2 Music Hall Block.

H. G. Reed, surviving member of the firm of Reed & Barton, Taunton, Mass., is seriously ill.

R. J. Cushing, Bangor, Me., will shortly sell out one-half interest in his business to F. H. Owen.

The bans of marriage of H. C. Graffe, Fort Wayne, Ind., and Mrs. Celia Beck have been published.

E. Longmate has given up business at Clarence Center, N. Y., and moved to Lockport, same State.

E. W. Folsom, Great Falls, N. H., has moved to a new location during the remodeling of his old store.

The location of the new clock factory in Elgin, Ill., will be on a strip of land known as the Wilcox-Larkin.

The Lancaster Nickel Works, Wilkesbarre, Pa., have shut down, owing to the poor quality of the ore.

W. Voeltcher, 55 Myrtle Ave., Brooklyn, N. Y., has given a bill of sale to his father Edward Voeltcher for \$4,000.

W. F. Foster, Holyoke, Mass., received last week an addition to his family, in the shape of a boy, his first child.

It is reported that Charles Wood, Flandreau, S. Dak., was last week swindled of \$1,000 by the green goods game.

The wife of D. C. McKee, Corning, N. Y., died suddenly last week. Mr. and Mrs. McKee had been married scarcely two weeks.

F. D. Barton, whose stock was somewhat damaged in the Converse House fire at Palmer, Mass., has settled his insurance for \$50.

C. H. Broadbent, Utica, N. Y., besides being one of the principal jewelers of the city, does an extensive business in Union bicycles.

Joseph Barborka, Iowa City, Ia., visited Wilmington, N. C., last week, to put in the big clock in the tower of the government building.

Holdridge & Peterson, Norwich, N. Y., have located in new quarters at 205 N. Broad St. They will hereafter devote special attention to optical work.

The jewelry stock of the late August Koenig, Ft. Wayne, Ind., has been purchased by Herman Berghoff, who will sell the goods as soon as possible.

H. Jorgensen, Mayville, N. Dak., has purchased the stock and good will of Lars Shaker, West Superior, Wis., and will conduct a general jewelry business.

Yale & Dillon, Gloversville, N. Y., have engaged the services of C. E. Hale, of Auburn, N. Y., a practical watchmaker and jeweler of fifteen years' experience.

W. W. Shuman, Huron, S. Dak., and Thos. Morris, Crookston, Minn., are in West Superior, Wis., looking for a suitable location for a jewelry store. Both are old jewelers.

Jos. Geist, Duluth, Minn., recently returned from New York, has started on a flying trip to the East. Mrs. Geist, whose health is poor, will be absent about a month.

The elegant office clock and all the silverware for the handsome Palmer House, Herkimer, N. Y., which was opened April 6th, was furnished by jeweler M. C. Prince, of that town.

W. G. Lippitt, Norwich, N. Y., has vacated his old stand opposite the Eagle Hotel, and is now situated at 230 N. Broad St. Mr. Lippitt has had the commodious store remodeled, and has put in a new stock.

C. L. Higginbotham, 22 years old, son of C. T. Higginbotham, formerly superintendent of the Hampden Watch Co., when the works were located in Springfield, Mass., died at Thompsonville, Conn., last Wednesday, of consumption. He leaves a widow.

W. A. Pfister, Sheboygan, Wis., has returned from Chicago, Ill., where he went to purchase the fixtures which will be placed in his store as soon as it is remodeled. His stock has been removed from the store, while the improvements are being effected.

Covell & Matson, Brockton, Mass., have moved to a new location under the Hotel Belmont, where a liquidation auction sale will be held. This sale is for the purpose of meeting the obligations of the firm, though they do not intend going out of business.

Anderson & Houghton, Little Falls, N. Y., have adopted a clever method of calling attention to their birthday rings. They publish in the newspapers a stanza for each month, with the appropriate stone, and at the end announce their stock of the goods.

During Sunday night, April 1, probably after the watchman went off duty at 4 o'clock, burglars entered the store of A. F. Skinner, DeLand, Fla., through a window in the rear; they broke out a light, then removed the fastenings, and carried away goods, mostly flat or silver ware, to the amount of about

\$200. The officers have been trying to get some clue, but nothing has developed yet that would warrant an arrest. The burglars are believed to have been negroes, strangers.

Superintendent Cain, of the Aurora watch factory, returned last week from a week's trip in the East, in the interest of the factory. Superintendent Cain says that the factory will put on an additional traveling salesman this week.

The Electric Signal Clock Co., Harrisburg, Pa., with a capital of \$50,000 were granted a charter last week. There are 1,000 shares, of which the principal are held by Dr. H. W. Fishel, J. L. McCaskey, and R. W. Fair. The directors are H. W. Fishel, R. W. Fair, H. C. Brenneman, J. W. Holtzinger, Dr. J. W. Ellenberger, Dr. Walter Pearce and John L. McCaskey.

Tried to Victimize Indianapolis Jewelers.

INDIANAPOLIS, Ind., April 8.—The local jewelers were much excited on Saturday by the capture of a young man named J. E. Meyers, who had secured a gold watch worth \$200 and a diamond stud worth \$100 from S. D. Crane's store, and who had attempted to victimize others. Meyers entered Mr. Crane's store accompanied by another young man, and their actions in the light of the after event, leads Mr. Crane to think they intended to make a grab and run. They were exceedingly hard to please, inspected only rich goods and left.

Meyers probably saw Mr. Crane had mistaken him for an expected customer, which was the fact. He resembled a young man whose mother had already purchased one fine gold watch of him for a son, and had promised to send another son to look at another watch. The consciousness of this, Mr. Crane thinks, probably led to the abandonment of the grab game.

Meyers said he was undecided which he wanted most, the watch or diamond stud, and if he could be allowed to take them to his mother—his buggy was at the door—he would return with them in half an hour. Mr. Crane consented, but the half hour being long passed, he became suspicious and sought police assistance. He found Meyers was already wanted for personating the fictitious son of a prominent banker, and obtaining two diamond rings, valued at \$80 each, from E. Emanuel, and goods from other stores, on a forged check.

Meyers was shortly after arrested on the street with a scalper's ticket to St. Louis in his pocket. The watch and diamond were found in his overcoat sleeve. In his pocket were found pawn tickets issued by brokers in Albany and Buffalo, N. Y.

He waived examination, and his case went to the grand jury. W. T. Marcy, L. F. Kiefer & Son, and Bingham & Walk were the other intended victims, and were requested to set goods aside for Meyers, who said he would call for them later in the day.

The prisoner is doubtlessly the person who it is alleged endeavored to swindle Albany, N. Y., jewelers on April 1st.

The Smith-Clews Suit Terminated After Twelve Years.

By a decision of the New York Court of Appeals a litigation that has lasted for ten years over a pair of earrings was terminated last Wednesday. The case will go down in legal history as being the hardest ever fought in the American jewelry trade.

The plaintiffs were: Alfred Smith & Co., of 152 Broadway, New York, and the defendant, Henry Clews, the banker. The case went to trial in the Trial Term of the Supreme Court three times, was reviewed by the General Term of that Court three times and likewise by the Court of Appeals three times. Thus the case has been heard in Court nine times.

In 1879 Mr. Clews bought a pair of diamond earrings from Elijah Miers, paying \$1,100 for them. Miers had been entrusted by A. H. Smith & Co., with the diamonds to sell to Mr. Clews, but never returned the money for them, and even after being placed in prison failed to do so. The firm demanded the diamonds from Mr. Clews, and when he refused to surrender them, began suit for their recovery. The case was tried in the Supreme Court but was dismissed, by the Judge, without the case being allowed to go to the jury. The General Term affirmed this decision and in the Court of Appeals the case was sent back for a new trial.

On the second trial a verdict was rendered for Mr. Clews. Again the case was taken to the General Term which sustained the ver-

dict. An appeal was taken to the Court of Appeals and a new trial asked, on the ground that important evidence had been omitted in the previous trials. The Court of Appeals again sent the case back for its third trial. A. H. Smith & Co. introduced testimony to show that it was the custom of importers to accompany with a memorandum, diamonds sent out to customers. The other side claimed that it was not.

Mr. Clews now appealed. He took the case to the General Term in 1889, but the decision there was against him, the opinion of the judge being at the time published in THE CIRCULAR. Then he sought the Court of Appeals and it now finally settles the case in favor of the plaintiffs. The judgment against Mr. Clews is for \$3,016, which includes the value of the diamonds, the interest on this value and cost of the legal proceedings.

Providence Creditors.

PROVIDENCE, R. I., April 10.—As the season advances the results of poor collections and stringency of money manifests themselves in the failures in all parts of the country, and already the amounts involved foot up in the aggregate to a surprising total.

By the recent failure of Sol. Bergman & Co., of Omaha, Neb., members of the Manufacturing Jewelers' Board of Trade of this city are creditors for between \$10,000 and

\$12,000, while the total indebtedness in this vicinity is from \$18,000 to \$20,000.

The compromise offer of forty cents on the dollar which has been made by Erlich Bros., Chicago, Ill., is not meeting with any flattering degree of favor in this vicinity. The total liabilities of the firm are \$24,306.50. In this city the creditors are: Albert Eddy & Co., Crossin & Tucker, Capron & Co., Clarke, Black & Co., D. R. Childs & Co., D. F. Adams, Foster & Bailey, Howard & Son Co., H. C. Lindol, Harvey & Otis, J. W. Grant & Co., J. P. Cory, Kirby, Mowry & Co., Martin, Copeland & Co., Ostby & Barton, Potter & Buffinton, Reynolds Jewelry Co., Smith Brothers, Seery Mfg. Co., S. & B. Lederer, Union Eyelet Co., W. A. Beatty & Co., W. R. Richards.

McBride and Marcellus at War.

CLEVELAND, O., April 10.—The McBride & Marcellus Co.'s affairs are to be still further aired in the probate court next week. It appears that after several attempts to obtain the keys to a number of paste-board boxes in one of the safes, the appraisers who looked over the stock broke them open. C. E. Marcellus, the junior member of the firm, was absent at the time and was supposed to have the keys in his possession.

H. W. McBride, the senior partner in the concern, has spent much of his time for the last seven months in Akron. His occasional appearances here were usually the signal for a movement in the store, and he discovered

H. A. WADSWORTH & CO.

MANUFACTURERS OF

GOLD · FILLED · WATCH · CASES,

NEWPORT, KY.

by dint of questioning the other clerks that an electric bell had been arranged to summon Mr. Marcellus from the packing room on his arrival. A given signal announced Mr. McBride, another being used for all other purposes. Mr. McBride was not informed of this arrangement until after the assignment. A corner of the front room, in which the signal bell was located, was curtained off from view from the doorway, so that the signal would not be noticed by a newcomer.

The partners have engaged separate attorneys and are fighting each other as hard as they fight external creditors. These accusations are denied by the persons interested, and each will be ventilated at the numerous examinations to be had. Mr. Marcellus is now in the East negotiating with the manufacturers who are creditors of the concern. Mr. McBride is in town, and is said to be preparing to move against his partner.

New Light on the Sumner Bros.' Failure.

CLEVELAND, O., April 10.—The creditors of Sumner Bros. are making matters very interesting for the members of that firm, their agents, assignee and others connected with the case. Charles Zucker, who is attorney for Trustee R. E. Burdick, has been in Wisconsin investigating several branch stores operated by Sumner Bros., and has met with some interesting adventures.

In the report which Mr. Zucker filed Wednesday, he says that the trip began March 31st, and that he first went to the city of Chippewa Falls, Wis. There he found that one H. H. Rowe, who is named on the books of Sumner Bros. as their agent in operating a jewelry store at that place, was in fact the absolute owner of the store, which contained a stock valued at \$10,000. Mr. Rowe owed the estate of Sumner Bros. about \$2,000 in open account, which he said was not yet due. Mr. Rowe was upon the eve of selling his stock at auction when the attorney arrived, and M. A. Sumner was at the same time in Chippewa Falls, for the purpose of assisting Rowe in conducting the auction.

The outcome of the attorney's visit was that he obtained a chattel mortgage for \$2,695 in full of the account, and took possession of the entire stock, placing an agent in charge at \$10 a week, with the understanding that the auction would take place without expense to the creditors of Sumner Bros., and the mortgage was to be the first claim paid out of the proceeds of the sale.

The total amount realized by the attorney was \$3,900.

The alleged action of M. A. Sumner in attempting the disposal of goods in a distant city gave point to suspicions heretofore entertained by the creditors that the assignment had not been made in good faith, and they at once began operations to investigate more thoroughly into the facts. R. E. Burdick, trustee of Sumner Bros., by Peter Zucker, his attorney, filed a motion, Wednesday, in the Probate Court for the examination of sundry parties, touching the firm's assets.

We offer about 75 dozen Ball's Eye Glass Hooks, in Gold, Rolled Plate, Oxydized Silver, Nickel Plated and Lacquered, at 33 1/3 per cent. below regular prices, to close them out. The goods are bright and clean. Doubtless they will be taken quickly at the large special discount, and if you want to see samples, you had best order promptly.

Bowman & Musser,

Importers and Jobbers,

Watches, Chains, Spectacles, Tools and Materials,
Lancaster, Pa.

The "CLEOPATRA"

PATENT APPLIED FOR.

A NOVELTY IN SOUVENIR SPOONS,

In keeping with the latest fad.

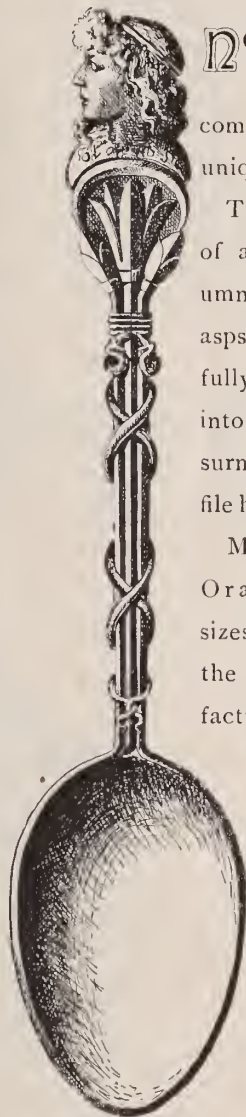

NO stock of Souvenir Spoons complete without this unique design.

The handle consists of an Egyptian column encircled by two asps, the top gracefully branching out into the lotus flower, surmounted by a profile head of Cleopatra.

Made in Tea, Orange and Sugar sizes. In addition to the above, we manufacture a large variety

of Souvenir Spoons, applicable to various localities, photos and prices of which will be furnished on application.

ALVIN MFG. CO.

860 Broadway,

NEW YORK.

Factory, 24 Boudinot St., Newark, N. J.

ROGER WILLIAMS

Souvenir Spoon.

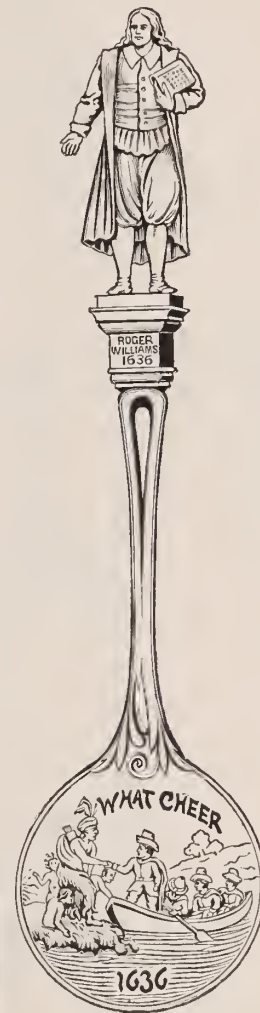

"In sixteen hundred thirty-six, Roger Williams got into a fix, By saucing the Governor of Massachusetts, And skedaddled away to Rhode Island."

MADE IN

TEA, ORANGE

SOUVENIR

AND

COFFEE STYLES

SEND FOR
Circulars and Prices

HENRY C. WHITTIER,

174 Westminster Street,

PROVIDENCE, R. I.



ROGERS & BRO. A-1.

OLDEST BRAND AND HIGHEST GRADE OF

ELECTRO SILVER PLATE.



For Hollow Ware.

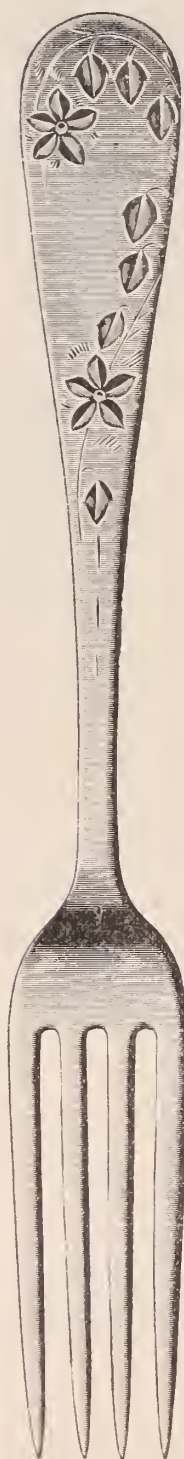

THE
"BELLE"
PATTERN.

SATIN FINISH
HAND
ENGRAVED.

MANUFACTURED BY

ROGERS & BROTHER,

WATERBURY, CONN.

No. 16 CORTLANDT ST., N. Y.

Mr. Burdick alleges that C. E. Sumner, M. A. Sumner, F. L. Sumner, Edward Sumner, Mrs. B. C. Sumner and C. S. Moross, are holding, concealing, or have carried away assets, and that E. J. Weil, their attorney, and T. H. Graham, the original assignee, know something about it. The motion was granted.

The examination of T. H. Graham took place yesterday. He said that Sumner Bros. obtained a large loan from E. J. Weil upon a thirty-day note, giving diamonds valued at \$7,500 as security. After the note became due Mr. Graham borrowed the money to take up the note and placed them in the hands of Charles Gale, a student in the office of Estep, Dickey, Carr & Goff, who holds them as security. No mention was made of the gems in the inventory as they had not at the time of the assignment been turned in as assets. The examination of several other witnesses was set for a later day.

CLEVELAND, O., April 12.—The probate court yesterday morning confirmed the sale by Trustee R. E. Burdick of Sumner Bros.' stock to Sipe & Sigler through Attorney F. E. Dellenbaugh for \$32,500.50. The purchase was a cash transaction.

Platinum is found, says the Edmonton, N. W. T., *Bulletin*, in the Saskatchewan River, in connection with gold.

Astronomers Want to Supply Standard Time.

WASHINGTON, D. C., April 10.—The leading astronomers of the United States are uniting their forces to have the control of the U. S. Naval Observatory in this city, otherwise known as the U. S. National Observatory, transferred from the Navy Department to a Board consisting of men of scientific and astronomical training and ability, who shall thereafter constitute an astronomical department of the government machinery.

The cause of this movement is the step recently taken by the United States Naval Observatory which inflicts a very baneful effect upon the various astronomical observatories of the country. This is the practice established of supplying the Western Union Telegraph Co., gratuitously with time signals for commercial use.

The sums received from railroads in payment for the time and other signals furnished by this circuit, formed the main support of the observatories, and now the system adopted by the United States Naval Observatory of supplying time signals to the Western Union Telegraph Co., which, with their extensive electric system can do the work much cheaper, though, it is claimed, with less accuracy, will drive the university observations from the field. The universi-

ties say that with the Western Union system adopted, the only means they have of advancing the cause of science will be withdrawn, and their costly plants will be rendered useless. The memorial to the next Congress, which it is intended to present, will have the signatures of the most prominent astronomers of this country.

Farmers Hoodwinked by a Peddler.

MILWAUKEE, Wis., April 8.—Farmers in Outagamie county, this State, are in a foment over the sharp practices of a party who canvassed their district with an abundance of cheap jewelry and watches. Cases sold for solid gold are proving to be the worst of imitation gold, and rings that were gold under the influence of the glib scamp, are now tingling, not tinkling, brass.

There is another interesting feature of the affair. Jeweler Max Mayer, Appleton, this State, is daily beset by farmers who were told that when their watches got out of order Mr. Mayer was under contract to repair them free of charge.

Thomas Davis Honored.

PROVIDENCE, R. I., April 11.—Yesterday afternoon Hon. Thomas Davis, formerly of the old manufacturing jewelry firm of Sackett &

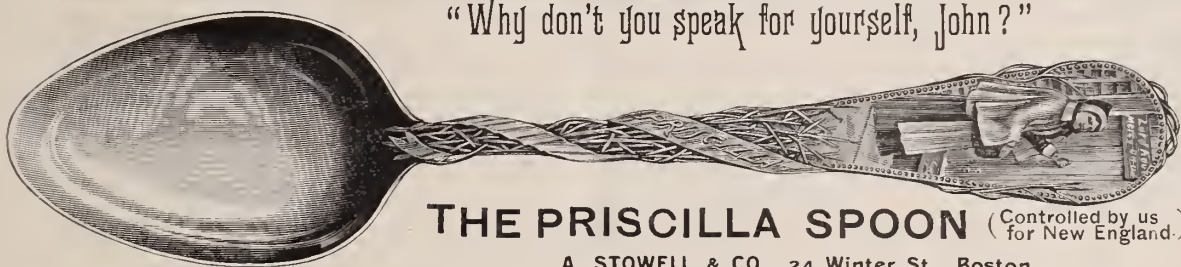

“Why don't you speak for yourself, John?”

THE PRISCILLA SPOON (Controlled by us for New England.)

A. STOWELL & CO., 24 Winter St., Boston.

“WITCH SPOON” discounts to the Trade. Retail prices as follows: Coffee Spoons, \$1.25, Tea Spoons, \$2.00, Orange Spoons, \$2.25. 25 cents added charge for Gilded Bowls. We believe this spoon conveys the purest sentiment for Engagement Souvenir or Leap Year Purposes. It is difficult to imagine a Souvenir Spoon better adapted to the general demand than the “Priscilla.”

As an engagement or sentimental remembrance, embodying as it does, Puritan simplicity and maiden sweetness, it has no equal, and we predict a large demand for it as a LEAP YEAR SPOON, for how delicately would a “laggard in love” be stimulated by the gift of a fair counterfeit of her who so naively said, “Why don't you speak for yourself, John?”

CONTROLLED FOR NEW ENGLAND BY

A. STOWELL & CO., BOSTON.

THE LYNN “DUNGEON ROCK” SOUVENIR SPOON.

(REGISTERED TRADE MARK.)

Dungeon Rock is widely known as the supposed resort of Captain Kidd and his band of Pirates.



Owing to the great demand for a Lynn ‘Souvenir Spoon, we have designed, the above, taking for our subject, the well known legend relating to the cave of Captain Kidd, known as “Dungeon Rock,” and situated near the sea-coast in Lynn. The spoon is odd and unique not only in design but in shape. It is meeting with ready sale, and we are confident will be a profitable addition to any line. We are already receiving orders from retail dealers in all parts of the country. Will mail price list and circulars on application.

254-256 UNION ST. **H. M. HILL & CO.,** LYNN, MASS.



ANOTHER "WITCH" SPOON.

REGISTERED TRADE-MARK.

BELIEVING there is always a demand for that which is most unique and artistic, we have originated another "Witch" Spoon of a more elaborate design than any souvenir spoon yet produced.

On the handle are all the features connected with the witchcraft delusion, the place and date, the cat, the broom, the rope, the witch pins, the new moon, and surmounting all, the witch. The reverse side carries out the idea of the front, yet the shape of the spoon is such that it can be conveniently used, the orange spoon, with its deep bowl and sharp point, being especially practical.

Of sterling silver, of heavy weight, and of the finest workmanship, it can hardly fail to be the the most attractive piece in any collection or on any table.

PRICE LIST.

Coffee Spoon,	-	-	-	-	\$1.75
"	Gilt,	-	-	-	2.00
Tea Spoon,	-	-	-	-	3.00
"	Gilt,	-	-	-	3.50
Orange Spoon,	-	-	-	-	3.25
"	Gilt,	-	-	-	3.50

Discount to the Trade:

25% less 3% 10 Days.

The "WITCH" Pin.

REGISTERED TRADE-MARK.

◀ The most unique novelty in the Souvenir line. ▶

To the Trade:

\$7.50 a dozen, Retail for \$1.00.

In ordering the above spoons be particular to write for second pattern.

DANIEL LOW,

ORANGE SPOON. 231 Essex St., SALEM, MASS.

S. C. JACKSON, 180 BROADWAY, NEW YORK, MANUFACTURER OF

Fine Cases for Jewelry, Silverware, Etc.,

ALSO SHOW CASE TRAYS AND FANCY HARD WOOD WORK. Samples sent on application. Estimates furnished.



Davis, received one of the most honorable testimonials of regard that is ever bestowed on a citizen of the United States. He was visited by a committee appointed from the older colored citizens of the State, and presented with a set of resolutions memorializing his labors on behalf of the colored race at the time he was in Congress, 1823 to 1855, and in the warmer slavery agitation of the years just prior to the War. The resolutions were adopted at a meeting of the colored people in Sumner Hall, Wednesday evening.

Eastern Manufacturers Enjoy Themselves.

PROVIDENCE, R. I., April 9.—For several years past it has been the custom of the New England Jewelers' Manufacturing Association to arrange for a mid-winter meeting, which is particularly intended for the enjoyment of female members and friends of their families. These annual ladies' receptions are among the pleasantest social events of the season and are looked forward to for months. The reception in Spink's assembly rooms last night, proved to be a remarkably brilliant and successful occasion in point of numbers, picturesqueness of costumes and decorations and social selectness, and completely outshone any previous reunion of the Association, in which are included representative houses in this city and Attleboro, Mass. The management of the entire affair was in the hands of J. M. Buffinton, of Potter & Buffinton, F. T. Pearce, of Frank T. Pearce & Co., and H. G. Smith, of Smith & Greene.

Owing to the prevalence of the grippe, there was a comparatively small representation from the Attleboros, but a goodly number of Providence members served to swell the attendance.

At nine o'clock the grand march was commenced, led by President Edwin Lowe and daughter, followed by F. T. Pearce and wife, J. M. Buffinton and wife and a brilliant retinue numbering between fifty and sixty couples. The costumes of the ladies were

THE NEAL DOW PORTLAND SPOON.



A fine likeness of the veteran "FATHER OF THE MAINE LAW," in heavy Sterling Silver.

We also have the FOREST CITY, WHITE HEAD, OLD ORCHARD and MT. DESERT spoons.

The Dow spoon at \$3.50, and Forest City at \$3.25, are ready for delivery; the others will soon be ready. The usual trade discount.

CARTER BROS.,

521 CONGRESS ST.,

PORTLAND, ME.

generally elaborate and tasteful, embracing many pretty and artistic combinations of color and material, which combined with the grace and beauty of the wearers, and the sparkle of jewels and fragrance of flowers, enhanced the charm and attractiveness of the picture.

Excellent music was furnished by Baker Brothers' Orchestra, augmented for the occasion. During the intermission Caterer Tillinghast provided a tempting supper, and the festivities came to a delightful termination at one o'clock. F. T. Pearce officiated as floor manager, with J. M. Buffinton, A. A. Bushee, W. S. Hough, Jr., C. H. French, W. O. Clark and G. H. Holmes as aids.

That Watch Club in the Northwest.

DULUTH, Minn., April 9.—Considerable comment has been caused among local jewelers by the outcome of the suit against the Imperial Watch Co., mentioned in a recent dispatch in THE CIRCULAR. It appears that through some oversight, or perhaps neglect on the part of the county Attorney Tear, who conducted the prosecution, the charges brought against the company did not conform to the evidence produced, and the case was dismissed. It is safe to say, that the end of the matter is not yet arrived, for it intended that new proceedings shall be instituted just as soon as practicable.

It is reported that Agent Wells, representing the Imperial company, has suddenly left town. When his office was visited, it was found to be closed and an employé of the building said that Wells had been absent about a week. A local agent named Cressey is, however, conducting the work of collecting from the clubs.

Robbed in Bright Daylight.

ST. PAUL, Minn., April 8.—On Monday as daring a robbery as has been recorded in the criminal annals of this city took place between 10 and 11 o'clock in the forenoon. T.

Gaskill's store, at 102 E. 4th St., was entered by a burglar, who succeeded in carrying off about \$100 worth of silverware. In the rear of the building is an apartment occupied as a real estate office by A. Rene, and it was through this room that the burglar made his entrance.

He had smashed a small window and crawled in through it. Gaskill's stock of jewelry was stored away in two safes, which were not tampered with by the robber. He took the silverware from the showcases. The robbery was not discovered until the afternoon. Several men who were in an adjoining restaurant heard the crash of the window, but it never entered their minds that a robbery was being committed. As yet the police have no clue of the burglar.

Dedicating a New Jewelry Factory.

TAUNTON, Mass., April 9.—The dedication of the new jewelry manufactory building, at Chartley, near here, owned principally by W. A. Sturdy, of Attleboro, this State, took place last evening. There were over two hundred couples present, Nye's orchestra of Taunton, furnished music, and refreshments were served by a prominent Boston caterer.

The building is 125x35 feet, and is two stories high. This building was some months ago blown down during a storm, when only partly constructed, and the work had to be done over again.

The Policeman Was Not in Sight.

CHICAGO, Ill., April 9.—The store of H. W. Duncanson, 759 W. Madison St., was broken into and robbed at 4.30 o'clock Monday morning. It has always been the custom of the jeweler to expose a number of gold watches in the window and frequently they are allowed to remain there over night with dozens of rings, charms and chains. This was the case on the night of the robbery, when the thieves, armed with a railroad coupling pin, battered in the French plate glass.

The noise of the battered glass as it fell to the sidewalk and on the inside of the store could be heard for half a block, but not a policeman was in sight. In fact, the policeman, if there was one on that beat, is not aware of the robbery yet. Pedestrians passing by the jewelry house would stop, look in the store at the valuable goods, remark that it was a shame that there was nobody to guard the goods and pass on. Many costly articles were in easy reach of any one who felt disposed to pick them up, and it was not until 7:30 o'clock that the proprietor and his property were protected.

The loss in jewelry will reach \$200 and the damage to the glass is about \$100.

Who Owns This Jewelry.

EAST GREENWICH, R. I., April 10.—A few days ago a young couple, giving the name of Mr. and Mrs. "Walt" Fletcher, came to this town and engaged board, the young man obtaining employment in the coal yards. Where they came from no one could find out, and the strange character of their baggage, an old gunny sack, created the greatest curiosity. However, before any light could be thrown upon the mystery of the youthful strangers, officers from Glasgow, Conn., arrived and arrested them—the little lady for running away from home and the young man for abduction.

In packing up, the officers became curious of the bag and an investigation revealed that it contained a large lot of valuable jewelry. Fletcher, for a long time had been suspected with one Charley Wells, a farmer's boy, of having robbed a Glasgow jewelry store early last February, but up to this time, although Wells has been taken within a few days on suspicion, the officers had never been able to trace anything to their door. The financial extent of the operation was something like \$2,500, and no part of the goods had been recovered up to Fletcher's arrest.

The commercial directories give no names of jewelers in Glasgow, Conn.

London: 27 Holborn Viaduct, E. C.

New York: 24 Maiden Lane.

E. AUG. NERESHEIMER & CO.,

DIAMOND * CUTTERS

AND IMPORTERS,

Removed to No. 24 Maiden Lane.

PREMIUM LIST.

TO THE RETAIL TRADE:

We want 10,000 new subscribers added to our subscription list, and in order to get them we make some remarkable inducements for a LIMITED TIME ONLY.

SEND US TWO DOLLARS,

the regular subscription price of THE CIRCULAR, and we will send you any of the combinations described below, and

THE JEWELERS' CIRCULAR FOR ONE YEAR.

The articles in any of these combinations if purchased separately would cost from \$2.00 to \$3.00. They have been carefully arranged by an expert watchmaker as being such as are called for in every day's experience. They are first-class goods, will be carefully selected, and sent promptly.

In ordering, be particular to do so by the letter as arranged.

COMBINATION A.

Two dozen American Cock and Foot Jewels, assorted as follows:

1/4 doz.	Waltham,	18s.	O. M.,	Cock.
1/4 "	"	18s.	"	Foot.
1/4 "	"	18s.	N. M.,	Cock.
1/4 "	"	18s.	"	Foot.
1/4 "	Elgin,	18s.	"	Cock.
1/4 "	"	18s.	"	Foot.
1/4 "	Illinois,	18s.	"	C.&F.
1/4 "	Hampden,	18s.	"	C.&F.

COMBINATION B.

Two dozen American Cock and Foot Jewels.

1/3 doz.	assorted	Waltham,	18s.	C. & F.
1/3 "	"	Elgin,	18s.	"
1/6 "	"	Illinois,	18s.	"
1/6 "	"	Hampden,	18s.	"
1/6 "	"	Rockford,	18s.	"
1/6 "	"	Columbus,	18s.	"
1/6 "	"	Peoria,	18s.	"
1/6 "	"	Seth Thomas,	18s.	"
1/6 "	"	Trenton,	18s.	"
1/6 "	"	Lancaster,	18s.	"

COMBINATION C.

Two dozen American Endstones, assorted.

Same as Combination A.

COMBINATION D.

Two dozen American Endstones, assorted.

Same as Combination B.

COMBINATION E.

Two dozen American Balance Staffs assorted as follows:

1/3 doz.	Waltham,	18s.	assorted	styles.
1/3 "	Elgin,	18s.	"	grades.
1/3 "	Illinois,	18s.	"	"
1/3 "	Rockford,	18s.	"	"
1/3 "	Hampden,	18s.	"	"
1/6 "	Columbus,	18s.	"	"
1/6 "	Seth Thomas,	18s.	"	"

COMBINATION F.

Eight dozen American Roller Jewels assorted as follows:

1 doz.	Waltham,	18s.
1 "	"	8s.
1 "	Elgin,	18s.
1 "	"	6 & 8s.
1 "	Rockford,	18s.
1 "	Illinois,	18s.
1 "	"	4s.
1 "	Hampden,	18s.

COMBINATION G.

Two dozen American Winding and Interwinding Wheels, assorted as follows:

1/3 doz.	Waltham,	18s.
1/6 "	"	8s.
1/3 "	Elgin,	18s.
1/6 "	"	6 & 8s.
1/3 "	Rockford,	18s.
1/3 "	Hampden,	18s.
1/3 "	Illinois,	18s.

COMBINATION H.

Two dozen assorted Yoke, Clutch and Click springs for Swiss Watches, the most desirable patterns and only those for which there is a constant demand.

COMBINATION K.

Six dozen assorted American Collected Hair Springs assorted as follows:

1 doz.	Waltham,	18s.
1 "	"	8s.
1 "	"	1s.
1 "	Elgin,	18s.
1 "	"	16s.
1 "	"	6 & 8s.

COMBINATION I.

Four dozen assorted Yoke, Clutch and Click springs for American Watches. Only such will be sent for which you will find steady demand.

COMBINATION M.

Two dozen *Harstroms* Pat. Casesprings, assorted sizes (considered to be the best and most easily fitted spring in the market.)

COMBINATION L.

One gross American Hands assorted as follows.

1 doz	18s.	Spade,	K. W.
1 "	18s.	"	S. W.
1 "	8s.	"	S. W.
1 "	8s.	Morning	Glory, S. W.
1 "	1s.	Spade,	S. W.
1 "	18s.	Moon,	K. W.
1 "	18s.	"	S. W.
1 "	18s.	Morning	Glory, K. W.
1 "	18s.	"	S. W.
1 "	18s.	Seconds.	
1 "	8s.	"	
1 "	1s.	"	

COMBINATION O.

Jewelry Findings assorted as follows:

1 doz.	Plated	Clipped	Catches.
1 "	"	"	Joints.
1 "	"	Roll	Plated Ear Wires.
3 "	"	Burnished	Pintongs.
1/3 "	"	R. P. Lever	Button Backs.
1/2 "	"	"	Spiral Stud "
1/3 "	"	"	Scarfpin "
1 "	"	"	Jump Rings assorted sizes.
1 "	"	"	Bracelet and Necklace Snap Catches.

COMBINATION P.

Two dozen fine American Mainsprings, assorted sizes, for Waltham and Elgin Watches.

COMBINATION N.

Five dozen assorted Clark's (4 screw) steel lift and catch case springs suitable for Swiss and American cases.

Philadelphia.

S. I. Pressville, 1316 Columbia Ave., has sold out to J. B. Buzby.

D. F. Conover and Simon Muhr were guests at last Saturday's banquet of the Five O'clock Club.

Two well known manufacturers paid this city a visit during the week, making social calls upon customers; John Day, of Day & Clark and W. R. Alling, of Alling & Co., New York.

W. W. Russell, representing A. D. Coe, the Chicago, Ill., optician, was in this city last week buying a large line of manufacturing tools, with special reference to lens work.

John P. Lansons has been placed under \$500 bail by magistrate McCarthy, on the charge of embezzlement of three watches, the property of the Federal Watch Co., by whom he was employed as a salesman.

W. S. Hamrick, 726 Chestnut St., gave William Alexander a diamond ring and stud to show to his father for the purpose of effecting a sale. Instead of doing this Alexander sold the articles, and the jeweler had him arrested. Magistrate Clement held him in \$600 bail for court.

L. A. Scherr & Co., on Saturday entered a judgment, with execution, for \$500 against F. X. Ganter, retail jeweler, 3802 Market St. The place has always been a good stand, but lately the business has been neglected. It is thought that Mr. Ganter's only other creditor is G. S. Lovell & Co., 1021 Market St.

Eighteen diamond rings, one diamond stud, three gold watches and a lot of other jewelry will be sold by Marshal Leeds on the 15th of this month. The jewelry is the property of Edward Squires, and has been confiscated because Squires failed to pay duty on it when he brought it into this country. Squires served nine months for his smuggling.

The limited partnership of James E. Caldwell & Co. expired by limitation on March 31. Mr. Caldwell died some three months ago. The firm has been reorganized under the old name, with J. Albert Caldwell, J. H. Brazier, H. B. Houston, Frederic Shaw and James Riley as general partners, and Sorach C. Caldwell, J. Albert Caldwell and R. A. Lewis, the executor of the estate, as special partners. This partnership commenced on April 1, and will terminate on March 31, 1892.

Local jewelry circles are discussing the trouble in which Joseph Sandman, H. Muhr & Son's Chicago representative, finds himself. The members of the firm are very reticent upon the subject. Young Sandman was formerly in the service of the firm in this city, and was so well thought of that two years ago he was appointed manager of the Chicago branch. The shortage in his accounts is placed at between \$3,000 and \$5,000, but Simon Muhr declines to give any figures. Sandman came back to Philadelphia with head bookkeeper Price a few days ago, made a full confession and asked to be forgiven. The firm have decided not to prosecute him, and it is understood that full

restitution will be made. There are many stories afloat concerning Sandman's operations in Chicago, his reckless handling of stock, his forced accounts and the inevitable woman in the case. No two of these appear to agree, and Simon Muhr refuses absolutely to say what rumors are true and what are false. The one thing reasonably certain is that the matter is not likely to be ventilated in court.

Cincinnati.

Louis Albert started out on Wednesday on a short tour.

Mr. McDonald, the popular traveler of the Courvoisier-Wilcox Mfg. Co. was doing some business in the city last week.

A. Herman has been out prospecting, and found things brightening up a bit. He said a few days of sunshine would work wonders.

Jos. Goesling, of Jos. Noterman & Co., is an old Woodward boy, and is taking quite an interest in the Woodward Club, of which he is a charter member.

A. H. Beer, Versailles, Ind., is in the city buying. G. H. Smith, of Lancaster O., and T. R. Furness of Waynesville, O., are also calling on the trade here.

Jos. Noterman & Co. have taken an office and salesroom on the second floor of the building they occupy, and are having it remodeled to suit their convenience.

E. V. Clerque, the New York manager of the E. Howard Watch and Clock Co., was the guest of A. Herman a few days this week. He is en route to the Pacific coast.

O. E. Bell is able to be out again. His work has been mainly this week to get his stock in shape, to open up for business. He does not know when he will take a trip. His health is a serious drawback to many plans that he had laid.

The noted burglar C. S. Ward, who was shot, at Youngstown, O., last week by the police while trying to effect an entrance into a store, will be recognized by the reader as a notorious jewelry thief. His injuries have been pronounced fatal.

Jacob Dorst, of Jonas, Dorst & Co., is a victim of a malarial attack to which he is subject about twice a year. It has proven very stubborn to manage this spring. Hugo Jonas and John Jepson, of that house, have their sample cases ready, and will start out just as soon as there is an indication of clear weather.

Gustave Fox & Co. contemplate a radical change in their office and salesroom. They intend to take out all the cases from their parlor and make it a fine reception room with all modern adjuncts. They will carry very few mounted stones. The stock will be chiefly of loose stones. The stock taken out on the road will also be loose. Mr. Kaufman's experience is that if the diamonds he carried had been unmounted his sales would have been larger. This house have a big trade in Elk goods this Spring; they have just completed some very elaborate pieces.

C. Hellebush has secured R. E. Hawkins, formerly of the Bowler & Burdick Jewelry Co., Cleveland O., to represent them on the road in the West. Mr. Hawkins has had six years' experience, as far as the Coast and up in Vancouver where he has had fine success. He will probably not go farther on this trip than Salt Lake City, Utah.

Newark.

O. G. Gonzales has moved into the Oak Hall Building at the corner of Market and Halsey Sts.

J. A. Lebkuecher, of Krementz & Co., was last week selected to serve on the Grand Jury, for the April term of Court.

W. E. Fowler, a watchmaker of Waltham, Mass., last week pleaded guilty to stealing a satchel in the Ferry St. station of the Central Railroad, in the Quarter Sessions Court.

The articles of incorporation of the new Riley-Klotz Mfg. Co., were recorded in the office of the County Clerk last week. The capital is \$200,000 of which \$100,000 has been paid in. The incorporators are J. M. Riley, Samuel Klotz, W. M. Clark and Thomas Nichols.

Two cheap jewelry peddlers were arrested on last Monday, at Harrison, for creating disturbance. There they gave their names as Jesse Smith and Michael Griffin, of this city. On Tuesday morning, Justice Mulligan, of this city, sentenced Smith to sixty days in the county jail, and allowed Griffin to go.

A. B. Morris, 355 Mulberry St., has given a chattel mortgage to W. C. Headley for \$3,828. Mr. Morris claims that he possesses sufficient assets to meet his obligations if given time, and with the view of placing his position before his creditors he has called a meeting of these for April 16, at 2 P. M., at the office of L. Kalish, 828 Broad St.

Pacific Coast Notes.

A. Muirhead, Auburn, Cal., will shortly open a new store at Selma, same State.

The souvenir spoon craze has reached Pomona, Cal., and W. S. Bailey reports an increasing trade in the Pomona pattern of coffee and tea spoons in sterling silver.

Mr. Golden, Carson City, Nev., recently secured an experienced watchmaker and jeweler who has been employed for several years by Geo. C. Shreve & Co., San Francisco, Cal.

The efforts to locate the Otay watch factory at San Jose, Cal., have not been relinquished and P. H. Wheeler, superintendent of the company says the enterprise is now practically assured. Among the subscribers to the enterprise is Henry Ahlers, San Jose, a well-known jeweler who has subscribed \$10,000. As soon as all the stock is subscribed the plant and machinery will be moved from Otay to San Jose. At this writing \$40,000 stock out of the \$50,000 has been subscribed for.

FOR SALE.

On account dissolution of partnership, *three iron safes.*
One fine large "Herring Patent Champion"

Balance of Stock. Also Fixtures, Shop Tools, &c., &c.
Must be sold before May 1st. Cheap.

Apply to

MOORE & HORTON,
11 Maiden Lane.

IT IS A FACT

that I keep the best
assortment of BOSS
and KEYSTONE
CASES in the East.

If you do not have what you can sell, send to me, and I will
send you a selection package. I also have on hand a large assort-
ment of **CHAINS AND CHARMS.**

All mail or express orders promptly filled.

E. A. WHITNEY, 403 Washington Street, Boston, Mass.

THE WENDELL ORANGE SPOON.

(OUR OWN DESIGN.)

The Prettiest and Best Selling Souvenir Orange Spoon on
the Market.

The name of your city etched in bowl.
Handles engraved all different.

Prices Very Reasonable.

Souvenir Tea and Coffee Spoons with name of your city,
or buildings, scene, statue, etc., etched in bowl to order.

All orders filled within one week.

We will etch the name of your city, with year, in bowls
of spoons of any make at \$4.50 per dozen net.

Send for new catalogue.

WENDELL MFG. COMPANY,

The only Silversmiths in the West.

63 to 69 Washington Street,

CHICAGO, ILL.



John P. Fellows Dead.

John P. Fellows, one of the oldest jewelers in the New York trade, died on Monday evening at his residence, 166 W. 126th St., at the age of 76 years.

Mr. Fellows had been connected with the trade since his youth. He was born in Troy in 1815, and went to New York when a boy. He became connected with the firm of Fellows, Wadsworth & Co., subsequently Fellows & Co., where he learned his business and passing through various grades was at the time of his death the head of the firm.

Deceased was the originator of the Harlem Club. He leaves a wife and two daughters. The funeral service will be held this evening.

Boston.

E. G. Tucker, of Worcester, Mass., was in this city on a buying trip last week.

George Garland formerly with M. Myers, has entered the employ of E. A. Cowan & Co.

Henry Cowan, accompanied by his family, is on a business trip through New York State.

Irving Smith, of Morrill Bros. & Co., will start to-morrow on a European trip on the *Columbia*.

President Fitch, of the American Watch Co., has been in Montreal, P. Q., during the week.

Charles Adler, of New York, formerly of Louis Strasburger & Co., has been visiting old friends in the trade here.

R. H. Cole, who was president of the American Optical Co. for forty years, has been here from Southbridge, Mass., during the week.

O. E. Burdick, 329 West Broadway, returned last week from a trip to Cuba and the Southern States. On his return he received the congratulations of his friends to the number of sixty.

A wedding reception will be given by D. C. Percival this evening, at his Newbury St. residence in this city, in honor of the marriage of his daughter, Miss Lillian H. Percival, and Herman Parker.

E. S. Beach, formerly with the J. M. Chandler Co., of Cleveland, O., has connected himself with E. A. Cowan & Co, of this city, as traveling salesman for the Western States and Pacific Coast.

C. D. Rood, of the Aurora Watch Co., has been in this city during the past week. Supt. Cain, of the same factory, was also East on business said to be connected with the concern's proposed removal to some New England city.

Salesmen in town last week were, P. J. Babcock, of Bates & Bacon, J. W. Morrow, of the Columbus Watch Co., and Mr. Untermeyer, of Keller & Untermeyer, New York; Mr. Cowell, of Cowell & Hall Mfg. Co., Wrentham, Mass.; T. B. Wilcox, of the Pairpoint Mfg. Co., New Bedford, Mass.; Walter Gardner, of D. Wilcox & Co., Providence, R. I.; J. W. Reddell, of J. W. Reddell & Co., Newark, N. J., on his first trip to this city for the new concern.

Gilbert T. Woglom Assigns.

Gilbert T. Woglom, the well-known black onyx jewelry manufacturer, 34 John St., New York, assigned last Wednesday to Isaac Cole, 52 Nassau St. His liabilities are said to be about \$10,000, with \$5,000 worth of assets. He gave a preference on a promissory note to the Chatham National Bank for \$2,175. The cause of the failure is said to be the extreme dullness in the onyx business caused by that class of jewelry being no longer in demand, except for mourning wear.

Mr. Woglom is at present confined to his home, 4 Ashburton Place, Yonkers, N. Y., with an attack of typhoid fever resulting from the grippe, and Assignee Cole has received a communication from Dr. Strong, who is attending the patient, stating that the latter will not be able to leave his residence before next week. G. T. Woglom has been in the jewelry business for about twenty-five years, being at one time connected with G. & S. Owen. About twenty years ago he started in business with Levi Miller under the name of Woglom & Miller. Three years ago Mr. Miller died and the business was continued by Mr. Woglom.

When seen by a CIRCULAR reporter, Assignee Cole said that he anticipated no legal complications in connection with the assignment.

The Large Chicago Fire Burns out a Jewelry House.

CHICAGO, Ill. April 12.—In the large fire that swept away valuable property on West Madison St., this afternoon, the store of A. Kaempfer, 150 W. Madison St., was gutted. Mr. Kaempfer carried stock amounting in value to \$3,500 mostly in three large safes, and one vault.

At the present time it is impossible to give the condition of the stock, which lays in the cellar covered with debris. The insurance is \$4,500.

The Failure of Sol. Bergman & Co.

OMAHA, Neb., April 11.—Sol. Bergman & Co., 1516 Farnam St., failed on Monday. The First National Bank of that city closed the business on a chattel mortgage on the stock and fixtures for \$1,960. Hammel, Riglander & Co., New York, also hold a mortgage for \$1,646. The insolvents had deeded to creditors real estate to the value of \$1,500, and mortgaged real estate to the value of \$1,147.

T. J. Smith, New York, has filed an attachment against the stock for a considerable sum, which he alleges is due him. The stock is at present in the hands of the attorney of the First National Bank. The attorney has taken security for Hammel, Riglander & Co.

Mr. Bergman was for some time in the employ of Max Meyer & Bro., and commenced business on his own account in 1888. The cause of the failure is attributed to slow collections. It is said that Mr. Bergman some days ago showed his bank a statement

which demonstrated that he would have ample funds to pay all his indebtedness if an extension of time was given to him. The bank refused to do this.

The total liabilities are not known; they will probably, however, be in the neighborhood of \$15,000 or \$20,000, the principal creditors being Attleboro, Providence, and New York houses.

The Jewelers' Security Alliance.

The regular monthly meeting of the Executive Committee was held at the Alliance office on the 10th. There were present, D. C. Dodd, Jr., President, Henry Hayes and David Untermeyer, Vice-Presidents, J. B. Bowden, Chairman, C. G. Lewis, Treasurer, and Messrs. White, Karsch and Stuart.

The following were admitted to membership: C. C. Carroll, Wallingford, Conn.; Harold Dyrenforth, 67 Washington St., D. Kahn, 119 Madison St., E. Kirchberg, 240 W. Madison St., Metzberg & Co., 177 Madison St., Richards & Rutishauser, 78 State St., and S. Strelitz & Son, 98 Madison St., Chicago, Ill., Eugene Deimel, 151 Jefferson Ave., Kennedy & Koester, 201 Jefferson Ave. Jacob Keller, 236 Randolph St.; Frank S. Ring, 68 Woodward Ave., and Albert Schaub, 105 Gratiot Ave., Detroit, Mich.; M. Eliassof & Bro., Albany, N. Y.; C. P. Eells, 411 Adams St.; John Geo. Kapp, 415 Summit St.; Roulet & Armstrong, 341 Summit St., and Wm. Walcott, 407 Summit St., Toledo O.; Falk & Hecht, Broad St., Texarkana, Tex.; G. S. Penn & Son, Weatherford, Tex.; W. M. Ragland & Son, Waco, Tex.; J. P. Whitney, Tyler, Tex.; J. C. Woodlief, Waxahachie, Tex.; Kirtland & Gilmore, Utica, N. Y.; Gothard Lowenstein, 62 Broadway, and J. & P. Mayer, 734 Broadway, Brooklyn, N. Y.; Noyes & Huber, Paris, Tex.; Sipe & Sigler, 402 Superior St., Cleveland, O., and Z. V. Zimmerman, Little Rock, Ark.

Interesting Suit in New Jersey.

NEWARK, N. J., April 9.—An appeal from the First District Court in a suit of Jean Tack, 215 Market St., against John Norton, involving the possession of a watch, was heard in the Common Pleas Court on Wednesday morning. The case hinges on the question, whether Norton, who is a pawnbroker, was a purchaser under a law passed in 1889.

The law relates to constitutional sales, which embraces sales under the instalment plan, according to which the watch was sold by Tack to a man named Friedman, and calls for the recording of such sales in the Recorder's Office. In case of failure to do this, the seller cannot recover from a subsequent purchaser. Friedman pawned the watch at Norton's, who contends that under the law he is a "purchaser."

This is the first case of its kind in this State. Judge Kirkpatrick reserved his decision.

Henry Clews on Monday satisfied the judgment in favor of A. H. Smith & Co. for \$3,016.

THE UNITED STATES WATCH CO., WALTHAM, MASS.

Carry in stock a full line of their celebrated 6 size Ladies' watch, in nickel and gilt, 7, 11, 15 and 16 jewels, from plain to fully adjusted.



Also a complete line of 18-size Hunting and 16-size Open Face all grades, in nickel and gilt. The reputation of the United States Watches is too thoroughly established to require statement here—they excel in finish and time-keeping qualities those of any other make. Our factory at Waltham, Mass., is the model in automatic machinery and tool equipment. When you want a timepiece call for the United States Watch. On sale by all non-association jobbers, to whom retailers should apply for a complete line of these watches as they give less trouble and more satisfaction than any other. Address all communications to the UNITED STATES WATCH CO., Waltham, Mass.

"Rip Van Winkle" Tea Spoon.

... This Cut is less than 1-2 Size. ...



We have spared no expense in modelling this wonderful little statuette in Solid Silver of America's Celebrated Character in Romance. It is very heavy; very artistic.

We have the largest collection of Souvenirs in the City.

"Gen'l. Sherman" and "Miles Standish" just out. "Knickerbocker" and "Aneke Jans" and 30 others. \$1.25 to \$5.00. Send for Illustrated Price List.

Discount to the Trade.

J. H. JOHNSTON & CO.,
17 UNION SQUARE,
ESTABLISHED 1844. NEW YORK.

SOLID ✦ SILVER ✦ COFFEE ✦ SETS.

AFTER DINNER
COFFEE POTS

Odd and Unique Designs.



TURKISH, ✦ MOORISH,
AND
OLD ✦ ENGLISH
DECORATIONS,

With Sugar Dish,
Tongs and Tray to Match.

GORHAM MFG. CO.,

SILVERSMITHS,

Broadway and 19th St.,

NEW YORK.

ALFRED H. SMITH & CO.,

DIAMONDS,

182 BROADWAY,

COR. JOHN STREET,

NEW YORK.

33 HOLBORN VIADUCT, LONDON, E. C.

THE JEWELERS' CIRCULAR AND HOROLOGICAL REVIEW.

PUBLISHED EVERY WEDNESDAY BY

THE JEWELERS' CIRCULAR PUB'G CO.,
AT NO. 189 BROADWAY, NEW YORK CITY.

A JOURNAL DEVOTED TO THE INTERESTS OF
WATCHMAKERS, JEWELERS, SILVERSMITHS,
ELECTRO-PLATE MANUFACTURERS AND ALL
WHO ARE ENGAGED IN KINDRED BRANCHES
OF INDUSTRY.

Terms of Subscription, Postage Prepaid.

	PER ANNUM
United States and Canada, - - -	\$2.00
To all Foreign Countries, - - -	4.00
Single Copies, - - - - -	.10

ADVERTISEMENT.

Business letters, drafts, checks and post-office orders should be addressed to THE JEWELERS' CIRCULAR PUBLISHING COMPANY, No. 189 Broadway, New York city.

Manuscript from any quarter containing news or discussion of any technical subject within the field covered by THE CIRCULAR will be welcomed. Matter received that proves unsuitable or unavailable will be returned if accompanied by the necessary postage stamps.

Our editorial columns will contain our own opinions only, and we shall present in other columns only what we consider of interest or value to our readers. Applications to print advertising matter as news will not be considered.

Advertising rates in THE CIRCULAR are lower, considering the number of tradesmen reached by its large circulation, than in any other jewelry journal.

Notices of changes in standing advertisements must be received one week in advance, new matter can be received up to Saturday.

Member of the American Trade Press Association.

CLASSIFIED INDEX TO ADVERTISERS, PAGE 28.

VOL. XXII. APRIL 15, 1891. NO. 11.

Evolution of Style.

STYLES in jewelry are derived rather than created. The handiwork of the modiste exerts a decided influence upon the number and kind of personal ornaments worn, and this handiwork in dress, is, in a large measure, always in accord with the furnishings of drawing-rooms. At the present time, for example, what are known as Louis XIV. and Louis XV. styles are embodied in all three classes of decoration. These styles, of course, are greatly modified since the days of the Mesdames de Maintenon and de Pompadour, but they embody the same extravagance of gilt and glitter, with vivid dashes of color intermixed. In dress, the result is daring mixtures of hues in gowns and bonnets with lavish displays of jeweled laces and trimmings, gold and silver cords, gem-sprinkled draperies and the like. These fashions in turn, decide the proper amount and styles of jewelry to be worn, and we find that more gold and gem jewelry is being worn than has been for many years past. With the retirement of quiet colors and styles, certain articles of jewelry of modest

character have made way for more pretentious jewels. The principle upon which these changes rest is harmony—harmony in color, proportion, and form. Jewelers, therefore, who cater to a fine trade, should study the ever-changing peculiarities of styles in dress.

The Patent System Centennial.

THE patent system of the United States is now a century old. Of course the origin of all the details of the present system cannot be traced back a hundred years. Changes of greater or less importance have at different times been made in the patent laws and the system of administration thereunder. However, the system primarily was initiated a century ago. A celebration of the centenary of the Act of Congress of April 10, 1890, which provided that patents might be granted for the invention of any useful art, etc., "to promote the progress of useful arts," was in progress at Washington during Wednesday, Thursday and Friday of last week. The chief feature of the celebration has been a congress of inventors presided over by men of distinction and addressed by eminent speakers, who set forth the influence exerted by invention on the various branches of commerce and industry and on the professions. It needs only a statement of the results in figures to form an answer to any question regarding the utility of the system. Yet it is known that hostility to the patent system is constantly cropping up in and out of Congress. To the unbiassed observer, there is no doubt that the patent system does stimulate the progress of invention. The conclusions of common sense, and the accomplished facts seen all about us are evidence in this direction. Inventors are influenced by the magic of ownership and the desire for gain, as are other mortals; they have no motive to interest themselves in new inventions, outside the hope of gain; they do not exercise the gray matter of their brains for other people's benefit more than the generality of men. Still they are producers, and their work remains when they are gone. In the past one hundred years, one of the oldest sciences, horology, and one of the oldest arts, gold and silver smithing, have known advance where perfection seemed to have been reached. Invention combined with enterprise has, even within the memory of the generation, revolutionized horology in America. For sterling worth, the American watch is famous throughout the world. Improved machinery and processes are turning out finer silver pieces than our ancestors could have imagined. Therefore all should hail the hope of gain which the patent laws afford them a chance of securing. If the security and stimulus were taken away, it cannot be doubted that the inventive spirit would decline and humanity suffer. The American patent system is an institution which has stimulated the material progress of the country, and one which justly excites pride.

The Week in Brief.

A decision was rendered in favor of Wm. S. Hedges & Co., New York, against Payne, Steck & Co.—The statement of Imports and Exports for Feb., 1891, was issued—A new watch club system was organized in Newark, N. J.—The Galveston, Tex., watchmaker-cracksmen still under police surveillance—P. Mincowsky, Cincinnati, O., was arrested for receiving stolen goods.—G. W. Welsh's Son, New York, encountered a thief—The burglars who robbed H. Muller, Chester, Pa., were sentenced—Sol. Bergman & Co., Omaha, Neb., and G. T. Woglom, New York, failed.—The suit of Jean Tack, was brought up at Newark, N. J.—H. G. Reed, of Reed & Barton, Taunton, Mass., is reported dying.—Crooks endeavored to victimize Indianapolis, Ind., firms—The Smith-Clews suit, which has been in the New York courts for twelve years, was terminated—C. E. Marcellus and H. W. McBride, Cleveland, O., are still fighting each other in the courts—Some interesting developments in the failure of Sumner Bros., Cleveland, O., appeared. The Probate Court confirmed the sale to Sipe & Sigler—Astronomers want to control the standard time of the country—Farmers were hoodwinked by a peddler in Wisconsin.—Hon. Thomas Davis, Providence, R. I., was honored—The N. E. Manufacturing Jewelers' Association held their mid-winter meeting—T. Gaskill's store, St. Paul, Minn., was robbed in bright daylight—A new jewelry factory was dedicated at Charley, Mass.—H. W. Duncanson, Chicago, Ill., was robbed—A mysterious affair occurred at Cummings & Sons, San Francisco, Cal.—A. Kaempfer, Chicago, Ill., was burnt out—The Security Alliance held their monthly meeting—J. E. Caldwell & Co., Philadelphia, Pa., was dissolved and reorganized—The Riley-Klotz Mfg. Co., were incorporated at Newark, N. J.—John P. Fellows, of Fellows & Co., New York, died.

The Proposed Factory at Warren, R. I.

PROVIDENCE, R. I., April 10.—Several weeks ago an item appeared in THE CIRCULAR to the effect that a well-known manufacturing jeweler of this city was contemplating building a large factory at Warren, this State, and moving there.

The scheme was started by two well-known manufacturers (brothers) of this city with the idea of organizing a stock company with a capital of \$500,000 to erect a building and manufacture jewelry at Warren. Mr. Goff proprietor of the Warren Hotel agreed to contribute to the fund in land centrally located near the depot and a Mr. Martin, a contractor and builder was to erect the building and receive his payment in shares in the new company. At a recent meeting of the Mechanics' Machine Co., of Warren, the matter was discussed and the members were favorably inclined, provided the originators could obtain \$300,000 of stock outside of Warren.

New York Notes.

C. W. Schumann has obtained a judgment for \$72.06 against H. B. Brant.

P. Helman, 213 East Broadway, has given a chattel mortgage for \$120 to M. Bloom.

L. S. Friedberger & Co. has obtained a judgment against John Haas for \$30.00.

The Metropolitan Watch Co. has obtained a judgment for \$59.79 against G. W. Anness.

A judgment for \$255.10 in favor of Camerden & Forster, has been entered against C. R. Scott.

G. H. Blendeman, formerly of the New York Jewelers' Board of Trade, is now connected with the New York Jewelers' Association.

Charles Pickslay formerly with T. B. Starr, has rented a store in the new building on the northwest corner of Broadway and 20th St., where he intends opening a jewelry store.

The stock and fixtures of the New York York Brass Co. lamp manufacturers, at 37 West 14th St., were sold by the Sheriff last Thursday on executions aggregating \$56,000.

The suit of the Jewelers' Mercantile Agency against Bedell & Co., the printers, arising over disposition of the type of that organization's rating book, has been settled and taken from the calendar.

Among the new members of the New York Jewelers' Board of Trade are, Benj. Allen & Co., Chicago, Ill., E. S. Johnson & Co., 26 Maiden Lane, New York, and the Silver Plate Cutlery Co., Birmingham, Conn.

Julius Zeller, the assignee of Henry Rowlands, of Albany and Brooklyn, whose failure some years ago resulted in considerable litigation in the New York courts, died last Wednesday, at Albany, after a brief illness, of typhoid pneumonia.

Judge Newberger, of the City Court, last Friday directed a verdict for the plaintiff for \$703 in the suit of S. E. Zimmern, 8 Maiden Lane, against Edmund Heinecke, 29 E. Houston St. The judgment was the balance of an amount due for goods sold.

Albert Kahn, with Weis & Oppenheimer, is receiving the congratulations of his friends on his approaching marriage to Miss Carrie Baer, which occurs to-morrow at 735 Lexington Ave. The couple will probably spend their honeymoon in Europe.

Schedules in the assignment of A. de Riestal and G. de Riestal, importers of glassware and dealers in watches, whose failure has been previously reported in THE CIRCULAR, show liabilities of \$176,735.09; nominal assets \$222,924.15, and actual assets \$80,000.

J. B. Bowden, last Tuesday, gave a dinner to the past presidents and present officers of the Lincoln Club of Brooklyn. This was in accordance with a custom observed of late years by presidents just before their retirement from office and on this occasion, Mr. Bowden distinguished himself as a host.

W. H. Kemp, who at one time conducted a successful plated rolling mills, died suddenly of heart disease at his residence, 74 Perry

St., last Wednesday. Mr. Kemp was born in England, where his father was a gold beater and the son was brought up in the same trade. When about twenty-five years of age, he came to this country and settled in New York, where he established the first gold beating manufactory here.

The Jewelers' Building and Loan Association will, on May 5th, hold their annual meeting and election of officers. The following have been nominated by a committee appointed for that purpose: For trustee, C. W. Bridgeman, of Hayden W. Wheeler & Co.; for a directorship of four years, E. S. Johnson, L. W. Sweet, E. P. Ellsworth, A. L. Brown; for a directorship of three years, W. A. Smith, Julius Goldsmith, P. R. Ketcham, W. F. Lewis, Jr.; for a directorship of two years, Samuel Tickell.

Judge Ingraham, of the Supreme Court, in Chambers last Friday appointed a referee in the action brought by the Metropolitan Watch Co. against S. E. Fairchild. Mr. Fairchild, who is a lawyer and at one time was the legal representative of the company, is being sued for the return of certain leases and agreements which were placed in his hands for the purpose of obtaining judgment. He claims that the concern owes him

\$345 for services rendered, and is entitled under the law to retain the papers until he is paid.

The new time ball of the Western Union Telegraph Co.'s building will not be in position until about July. The ball will not be at the top of the building as heretofore. An ornamental iron arm projecting four or five feet has been attached to the corner of the building at Broadway and Dey St., above the ninth floor. On this will be the flagstaff, the top of which will serve as a place for the time ball. The ball will, as the noon hour approaches rise above the line of the building, and on the second it will drop to the level of the roof. The ball will be better seen from the street, but will not be visible as far away as it was before.

Edward Wetmore, attorney for C. W. Harman, last Monday made application to Judge Shipman of the United States Circuit Court to dismiss the suit of his client against David Untermeyer, Samuel Aufhauser and another. The motion was granted with the promise that the defendant's papers be filed with the court to remain a public record in all other proceedings ever brought against the defendants. The suit arises over a movement holding ring attached to a watch case centre

JEWELERS ATTENTION!

DO YOU KNOW that we are making the only line of cuff buttons which are sold exclusively to the RETAIL JEWELRY TRADE?

DO YOU KNOW that the action or fastening of this button is the simplest, most durable and most salable of any in the market?

DO YOU KNOW that we are manufacturing a full line of these buttons in roll plate, gold front and solid gold?

DO YOU KNOW that this line of buttons was endorsed and recommended by the OHIO RETAIL JEWELERS' ASSOCIATION?

DO YOU WANT a line of cuff buttons which is not found in any Dry Goods, Gents' Furnishing or Millinery Store in the country—thereby preventing such ruinous competition?

Then send to us for a selection of our "ANTI-SWEAR" Buttons

J. T. SCOTT & CO.,

SOLE MANUFACTURERS,

4 MAIDEN LANE, - NEW YORK.

by means of a screw connection which was patented some years ago by the plaintiff. Subsequently the latter sued the defendants for infringing the patent and the case has been pending since.

Secretary H. M. Condit, of the New York Jewelers' Board of Trade, returned last Monday from his trip to the West.

About a year ago J. P. Hendries was sentenced to seven years' imprisonment for stealing several hundred dollars worth of watches from William Doughty, then in business at 6 Maiden Lane. Hendries obtained the goods to sell on the instalment plan, but pawned them in various places. After Hendries' conviction Mr. Doughty began suits against the pawnbrokers to recover the timepieces, but while they were pending he failed. The suits were continued in the interests of the creditors, and last week were terminated before Referee R. M. Henry, by the pawnbrokers consenting to surrender the property. This settlement will result in the creditors of Mr. Doughty realizing more than they anticipated on their claims.

The Jewelers' Dining Club, an organization for the enjoyment of social intercourse among jewelers during the noon hours, was organized two weeks ago and has proven a great success, the membership already numbering fifty with a waiting list containing ten more names. The club meets at Dufort & Raymond's restaurant every day, where it has private rooms with special waiters and tableware and a special *table d'hote*. The present officers are E. J. Scofield, president; A. K. Sloan, secretary and treasurer and John Senior, Henry Abbott and F. R. Simmons, house committee.

He Was Not the Right Dromio.

A curious suit was decided in the New York City Court last week, after occupying two days in trial. R. & L. Friedlander, 65 Nassau St., New York, sued M. G. Ernest, 56 Canal St., to recover two gold watches, or \$199, their value, and costs amounting to \$140.

From the evidence it appeared that some time in March, 1888, Gustave Ernest, a brother of the defendant, called at R. & L. Friedlander's office and asked for two watches on memorandum for his brother. As he had often been sent for goods before, the firm did not hesitate in handing him the watches. It subsequently transpired that he pawned them and fled to Brazil.

At the trial of the case last Thursday the defendant's lawyer endeavored to show that the plaintiffs were not familiar with Gustave Ernest by producing a man who in appearance was his counterpart and giving him that name. Attorney E. L. Kalish, the plaintiff's attorney, however, frustrated the shrewd scheme by revealing the man's identity when he was on the witness stand, and the jury after being out but a short time returned a verdict for the plaintiffs. Among the witnesses called for R. & L. Friedlander were B. H. Knapp of Smith & Knapp and Jacob Moss.

The Attleboros.

J. A. Coddling was thrown out of a buggy last week and slightly injured.

Edward Gowen returned home Friday after a visit to Florida.

The chasers in Horton, Angell & Co.'s factory are so busy that night work is necessary.

C. E. Woodworth, formerly salesman for Wheaton, Richards & Co., was in town this week.

G. H. French, of Riley, French & Heffron, is building four large houses. W. H. Riley of the same firm is building two houses.

Charles Horstmeyer, with the Bay State Silver Co., and Miss Georgie Hillman were married at Providence, R. I., Thursday.

C. E. Polsey, W. B. Ballou and T. G. Sandland delivered addresses at the Knights of Honor annual banquet. Wednesday evening.

The residence of Henry Daggett, with F. M. Whiting & Co., was destroyed Tuesday by fire supposed to have been incendiary.

Commander W. H. Wade, of Wade, Davis & Co., and H. C. Cheever were delegates to the Bristol county G. A. R. convention Wednesday.

In a letter to a friend W. H. Smith, of Smith & Crosby states that he is recovering his health rapidly at Hot Springs, Ark., and expects to return home soon.

S. H. Bugbee, of Bugbee & Niles, delivered the oration to the P. M. Whiting Post 192 at the celebration of the G. A. R. 25th anniversary. Mr. Bugbee is compiling a history of the post.

Tappan, Berry & Co., have dissolved partnership, E. J. Berry retiring. The other partners merged with E. A. Leach and the firm will hereafter be known as the D. F. Briggs Co.

J. F. FRADLEY & CO.,

Manufacturers of a General Line of

REPOUSSÉ SILVERWARE, MATCH BOXES in Solid Gold and Stiffened Gold,

GOLD HEADED CANES, &c.

Office and Salesroom, 23 JOHN STREET, NEW YORK.

DORFLINGER'S AMERICAN CUT GLASS.

The Finest Crystal, Plain and Cut, made in the World.



EVERYTHING that is
used in Glass, for
the Table.

Sells as well as Silver-
ware.

EVERY FIRST-CLASS JEWELER

C. DORFLINGER & SONS,



BEAUTIFUL, Artistic
and Useful Pieces
for Gifts.

Rivals the Diamond for
Purity and Lustre.

SHOULD KEEP IT.

36 Murray Street, New York.

American Morocco Case Co.

FINE EBONY AND ROSEWOOD TRAYS FOR RINGS, WATCHES, ETC.

WHITE METAL CASES FOR RINGS, BROOCHES, ETC.

ONLY MAKERS OF

9 Bond St., N. Y.

HARD WOOD TRUNKS FOR SPOON WORK, ETC.

CLASSIFIED INDEX TO ADVERTISEMENTS.

All Advertisements are entitled to one insertion under proper heading. Extra insertions, \$6.00 per Annum. Extra Headings \$12.00 per Annum.

	PAGE.		PAGE.		PAGE.
Assayers & Refiners.		Hotels.		Stem-Winding Attachments.	
Goldsmith Bros., Chicago, Ill.	47	Russell House, Chicago, Ill.	42	Abbott, Henry, 4 Maiden Lane, N. Y.	35
Howard, S. P., 8 John st., N. Y.	48	Hotel Wellington, Chicago, Ill.	51	Sterling Silver Novelties.	
Robertson & Leber, 13 Franklin st., Newark, N. J.	48	Imported Clocks, Bronzes, Etc.		Alvin Mfg. Co., 860 Broadway, N. Y.	9
Auctioneers.		Glaenger, L. J., & Co., 80 Chambers st., N. Y.	33	La Pierre, F. H., 18 East 14th st., N. Y.	16
Comrie, A. J., 16 West 125th st., N. Y.	36	Jacques, Chas., & Co., 2 Maiden Lane, N. Y.	14	Lewis Bros., 41 Maiden Lane, N. Y.	14
French, J. H., Box 2775, N. Y.	45	Jewelry Repairers.		Sterling Silverware.	
Badges, Medals, etc.		Wiederhold, A., 20 Maiden Lane, N. Y.	44	Fradley, J. F. & Co., 23 John st., N. Y.	27
Stockwell, E. R., 1 John st., N. Y.	42	Jewelers' Scales.		Gorham Mfg. Co., 19 st. & Broadway, N. Y.	24d
Black Onyx Jewelry.		Troemner, Henry, 710 Market st., Philadelphia, Pa.	41	Shiebler, Geo. W., 6 Liberty st., N. Y.	12
Woglom, Gilbert T., 32 John st., N. Y.	40	Jewelry and Silverware Cases.		Towle Mfg. Co., Newburyport, Mass.	10
Books, Stationery, etc.		American Morocco Case Co., 9 Bond st., N. Y.	27	Wallace, R. & Sons, Mfg. Co., 3 Park Place, N. Y.	6
Pamphilon, H. W., 30 Bond St., N. Y.	45	Jackson, S. C., 180 Broadway, N. Y.	22	Wood & Hughes, 16 John st., N. Y.	14
Clock Manufacturers.		Wiggers & Froelick, 60 Nassau st., N. Y.	43	Souvenir Spoons.	
Waterbury Clock Co., 10 Cortlandt st., N. Y.	45	Jobbers, Watches, Diamonds, etc.		Alvin Mfg. Co., 860 Broadway, N. Y.	10
Chronometers.		Aikin, Lambert & Co., 23 Maiden Lane, N. Y.	42	Carter Bros., Portland, Me.	22
Heinrich, H. H., 14 John st., N. Y.	38	Beguelin, Tell A., 71 Nassau st., N. Y.	40	Conover, D. F. & Co., Philadelphia, Pa.	5
Cut Glass.		Bowman & Musser, Lancaster, Pa.	19	Durgin, W. B., Concord, N. H.	9
Dorfinger, C. & Sons, 36 Murray st., N. Y.	27	Conover, D. S. & Co., Philadelphia, Pa.	5	Freeman & Taylor, Boston, Mass.	31
Diamond & Precious Stone Importers.		Cross & Beguelin, 21 Maiden Lane, N. Y.	11	Galt, M. W., Bro. & Co., Washington, D. C.	29
Breidenbach, R. A., 51 Maiden Lane, N. Y.	14	Friedlander, R. & L., 65 Nassau st., N. Y.	40	Gorham Mfg. Co., Union Square, N. Y.	7
Gunzburger Bros., 35 Maiden Lane, N. Y.	38	Koch & Dreyfus, 22 John st., N. Y.	12	Gooding Bros., Plymouth, Mass.	9
Hedges Wm. S. & Co., 170 Broadway, N. Y.	49	Myers, S. F. & Co., 48 Maiden Lane, N. Y.	48	Hill, H. M., & Co., Lynn, Mass.	21
Kahn, L. & M. & Co., 10 Maiden Lane, N. Y.	48	Scott, J. T. & Co., 4 Maiden Lane, N. Y.	26	Johnston, J. H., & Co., 17 Union Square, N. Y.	24c
Kipling, E. E., 2 John st., N. Y.	48	Whitney, E. A., Boston, Mass.	24b	Low, Daniel, Salem, Mass.	22
Kipling, R. A., 31 Union Square, N. Y.	39	Lamps.		Norton, A. D., Gloversville, N. Y.	12
Neresheimer, E. Aug., & Co., 24 Maiden Lane, N. Y.	23	Eakins, G. & Son, Philadelphia, Pa.	44	Stowell, A. S., & Co., Boston, Mass.	21
Oppenheimer Bros., & Veith, 35 Maiden Lane, N. Y.	35	Musical Boxes.		Wendell Mfg. Co., Chicago, Ill.	24b
Randei, Baremore & Billings, 20 Maiden Lane, N. Y.	13	Jacot & Son, 298 Broadway, New York.	40	Whiting Mfg. Co., Union Square & 17th St., N. Y.	4
Smith, Alfred H. & Co., 182 Broadway, N. Y.	24d	Optical Goods.		Whittier, H. C., Providence, R. I.	19
Taylor & Bro., 860 Broadway, N. Y.	42	Geneva Optical Co., 23 Washington st., Chicago, Ill.	36, 39, 40	Tool Manufacturers and Dealers.	
Wheeler, Hayden W. & Co., 2 Maiden Lane, N. Y.	35	Levy, Dreyfus & Co., 11 Maiden Lane, N. Y.	31	American Watch Tool Co., Waltham, Mass.	34
Diamond Cutters.		Spencer Optical Co., 15 Maiden Lane, N. Y.	47	Bullock, O. W. & Co., Springfield, Mass.	40
Groenman, A. J. & Co., 80 Nassau st., N. Y.	16	U. S. Optical Co., 17 Union Square, N. Y.	36	Nordman Bros., San Francisco, Cal.	45
Diamond Jewelry.		Order Work.		Nicholson File Co., Providence, R. I.	14
Bynner, T. B., 177 Broadway, N. Y.	16	Maxheimer & Beresford, 3 Maiden Lane, N. Y.	39	Swartchild & Co., Chicago, Ill.	38
Falkenau, Oppenheimer & Co., 40 Maiden Lane, N. Y.	48	Pens, Pencil Cases, Etc.		Typewriters.	
Nissen, Ludwig, & Co., 18 John st., N. Y.	44	Aikin, Lambert & Co., 23 Maiden Lane, N. Y.	42	Wyckoff, Seamens & Benedict, 313 Broadway, N. Y.	38
Peckham, Chas. H., 63 Nassau st., N. Y.	13	Smith, H. M. Co., 83 Nassau st., N. Y.	16	Watch Companies.	
Sexton Bros. & Ashburn, 41 Maiden Lane, N. Y.	39	Ring Makers.		Illinois Watch Co., Springfield, Ill.	30
Stern Bros., 42 Maiden Lane, N. Y.	39	Bowden, J. B. & Co., 192 Broadway, N. Y.	10	Non-Magnetic Watch Co., 177 Broadway, N. Y.	42
Engravers and Designers.		Bryant, M. B. & Co., 10 Maiden Lane, N. Y.	10	Trenton Watch Co., Trenton, N. J.	44
Bartholomew & Peckham, 18 Spruce st., N. Y.	42	Hildreth Mfg. Co., 51 Maiden Lane, N. Y.	46	United States Watch Co., Waltham, Mass.	24c
Beecher & Clark, Louisville, Ky.	9	Ostby & Barton, 80 Clifford st., Providence, R. I.	12	Watch & Clock Dials.	
Ryder & Dearb, 146 Westminster st., Provi- dence, R. I.	41	Rolled Plate Chains.		Waltham Dial Co., Waltham, Mass.	42
Eye Glass Holders & Chains.		Barrows, H. F. & Co., 1½ A, Maiden Lane, N. Y.	42	Watch & Clock Oils.	
Merritt, S. F., Springfield, Mass.	43	Kent & Stanley, 7 Eddy st., Providence, R. I.	3	Ginnel, Henry & Co., 31 Maiden Lane, N. Y.	43
Gold and Silver Platers.		Rolled Plate Jewelry.		Nye, William F., New Bedford, Mass.	36
Newman, Louis, Jr., 36 John st., N. Y.	43	Crossin & Tucker, 409 Pine st., Providence, R. I.	43	Watch Keys.	
Gold Jewelry.		Flomerfelt, J. A. & Co., 177 Broadway, N. Y.	48	Clark, A. N., Plainville, Conn.	39
Bippart & Co., Newark, N. J.	37	Foster & Bailey, 60 Richmond st., Providence, R. I.	33	Kendrick & Davis, Lebanon, N. H.	44
Carter, Sloan & Co., 15 Maiden Lane, N. Y.	45	Ludwig, H. & Co., Providence, R. I.	42	Watch Case Manufacturers.	
Cottle, S. Co., 860 Broadway, N. Y.	40	Plainville Stock Co., Plainville, Mass.	40	Dueber Watch Case Mfg. Co., Canton, O.	16
Day & Clark, 10 Maiden Lane, N. Y.	9	Seamless Wire.		Essex Watch Case Co., Newark, N. J.	43
Krementsz & Co., 182 Broadway, N. Y.	33	Burdon Seamless Filled Wire Co., Providence, R. I.	40	Jeannot & Shiebler, 20 Maiden Lane, N. Y.	12
Larter, Elcox & Co., 41 Maiden Lane, N. Y.	13	Settings & Galleries.		Muhr's Sons, H., 629 Chestnut st., Philadelphia, Pa.	48
Moore & Horton, 11 Maiden Lane, N. Y.	24b, 44	Blancard & Co., 36 John st., N. Y.	40	Roy Watch Case Co., 17 Maiden Lane, N. Y.	48
Riley, J. A., & Scan Co., 860 Broadway, N. Y.	45	Show Cases and Fixtures.		Wadsworth, H. A. & Co., Newport, Ky.	18
Snow & Westcott, 3 Maiden Lane, N. Y.	9	Smith, B. & W. B., 220 W. 29th st., N. Y.	48	Watch Case Repairers.	
Street, Geo. O. & Sons, 15 John st., N. Y.	12	Silk Guards.		Feinier, G. F., 9 Bond st., N. Y.	38
Gold Chains.		Rosentall, Wm., 79 Nassau st., N. Y.	33	Felix, N. J., 71 Nassau st., N. Y.	9
Rickert & Stiehle, Newark, N. J.	42	Silver Plated Ware.		Watch Importers.	
Horological Schools.		Pairpoint Mfg. Co., New Bedford, Mass.	5	Abry, Chas. L., 41 Maiden Lane, N. Y.	38
Chicago School of Horology, Chicago, Ill.	3	Rogers, Wm., Mfg. Co., Hartford, Conn.	36	Didisheim, Hipp, 83 Nassau st., N. Y.	14
Elgin Horological School, Elgin, Ill.	16	Rogers & Hamilton Co. The, Waterbury, Conn.	48	Hydes' Sons, John E., 22 Maiden Lane, N. Y.	38
Jaeger, R., St. Louis, Mo.	14	Rogers & Bro., 16 Cortlandt st., N. Y.	20	Mathey Bros., Mathez & Co., 14 Maiden Lane, N. Y.	11
Waltham School of Horology, Waltham, Mass.	40			Wittnauer, A., 30 Maiden Lane, N. Y.	46

Special Notices.

Rates 75c. per insertion for notices, not exceeding 3 lines; additional words 2 cents each. If answers are to be forwarded, postage stamps must be enclosed. Two insertions, 10 per cent. off; three insertions, 15 per cent. off; four insertions, 25 per cent. off. Payable strictly in advance.

Situations Wanted.

THE JEWELERS' CIRCULAR has a guaranteed circulation of over 10,000 copies weekly. It is, therefore, the best medium for reaching the trade. To demonstrate this to advertisers, notices in this column will be inserted free of charge during the month of April.

NICKEL PLATER desires a situation; thoroughly understands the business; can give best of reference if required. Address, Plater B, this office.

DIAMOND LINE WANTED.—Mounted or loose; on salary and commission, by an experienced and reliable salesman. Address, Watson, P. O. Box 3278, New York.

POSITION WANTED.—By a young man in jewelry store as salesman; can also work at the bench; six years' experience; good reference. Address, A. H. T., 54 Berkley St., Taunton, Mass.

SITUATION wanted as clerk in retail, or traveler for wholesale jewelry house; nine years' experience in retail jewelry business; can give best references; New York, Philadelphia or Boston preferred. Address A. B. C., care of THE JEWELERS' CIRCULAR.

SITUATION wanted by a young man as credit clerk; understands position thoroughly; as well as all office work, bookkeeping, etc. Good reasons for wishing to make a change. Address, H., P. O. Box 3306, N. Y. City.

SITUATION WANTED.—By first-class rapid watchmaker, jobber and plain engraver; young man of pleasant address; good set of tools: A 1 reference. Address, G. W. C., 1125 Grand Ave., Pueblo, Col.

WANTED.—By a single man of about 30, with nineteen years' experience in the trade, a position as first-class watchmaker and repairer. Is familiar with the use of the lathe. Address, John Scherer, care THE JEWELERS' CIRCULAR.

YOUNG MAN, twenty years of age, would like a situation with a jewelry or optical house; has had experience in both lines of business; satisfactory references. Address Johnson, care of THE JEWELERS' CIRCULAR.

WANTED.—A situation for a good watchmaker that I can recommend. Address, W. F. A Woodcock, Winona, Minn.

Help Wanted

WANTED.—An experienced salesman in the silver plated ware trade (Hollow Ware); he is to make three or four trips during year, and to look up near-by trade; must be thoroughly acquainted with the jewelry and department store trade; good opening for the right man. Address A. S. P., care of the THE JEWELERS' CIRCULAR.

WANTED.—Optician and engraver, optician and watchmaker, and engraver who can assist in selling and displaying goods in a large Southwestern city; as engraver, work must be good; only competent men need apply, stating age, salary and references; steady positions are assured the right men. Address, Competent, care of THE JEWELERS' CIRCULAR.

WATCHMAKER WANTED.—Young man preferred with \$1,000 or more to add to an already established jewelry business; loan and pawn business in a city of 25,000 inhabitants; no such business in the city; fair trade and run of work; no fooling; strictly legitimate party. Address, G. F., 74½ Rensen St., Cohoes, N. Y.

For Sale.

A FINE ship chronometer for sale cheap. Address: A. C. Taylor, Cedar Rapids, Iowa.

FOR SALE.—On account dissolution of partnership, three iron safes; one fine "Herring Patent Champion"; also fixtures, shop tools, etc. Apply to Moore & Horton, 11 Maiden Lane, New York.

\$2,000 IN CASH and two thousand in notes, will buy old-established and paying jewelry business near New York. Address, Wm. McAdie, with Rogers & Bro., 16 Cortlandt St., N. Y.

Miscellaneous.

OPTICIANS.—We offer, very cheap, a brand new surface-grinding lathe, with complete set of moulds + 0.25 Ds to 18 Ds; correspondence solicited. Address, A. Jay. Cross & Co., 18 W. 23d St., New York.

TO MANUFACTURERS of Clock Movements.—Wanted, a good eight-day movement, to fit onyx and marble cases; send particulars and price for quantities to Case Manufacturer, care of THE JEWELERS' CIRCULAR.

WANTED.—On Maiden Lane or vicinity, a window and bench room for a watchmaker. Address, H. L., care of THE JEWELERS' CIRCULAR.

W. F. A. WOODCOCK'S SCHOOL FOR WATCH makers, Winona, Minn., offers unrivaled facilities for acquiring a thorough practical knowledge of every branch of the business. Terms very reasonable.

WORK FOR THE TRADE.—All kinds of watch and jewelry repairing. Skillful workmen, prompt attention and satisfaction guaranteed. Address, A. W. Johanson, 176 & 178 Market st., Chicago, Ill.

St. Louis.

Detectives Viehle and Ziegler arrested Thos. McCarthy last week and found on his person a pair of diamond earrings. The gems are set in the form of a star in rope-coil Roman gold, and are thought to have been stolen.

Joe Varner, alias Samuels, alias Diamond Sam, was brought back here on last Tuesday, from Chicago Ill., having been surrendered by his bondsman, J. J. Johnson. Varner was tried and convicted in the Criminal Court for a diamond robbery, amounting to about \$300.

G. H. Reynolds left this city on the 10th, for his home in Rutland, Vt., where he will superintend the shipment to this city of the machinery used in his onyx plant at that point. He expects to have the machinery on board the cars in a few days, and says the St. Louis plant will be ready to begin operations within sixty days.

Durkee & Zens, 1012 Olive St., recently gave a bill of sale on their entire stock to the Standard Jewelry Co. The Standard Company held the largest claim against them, and say that the stock will just about settle their debt. Durkee & Zens are said to have liabilities of about \$5,500, including the claim of the Standard Co., and as they have no assets outside of their stock, which has been turned over to the Standard Co., the prospects for unsecured creditors are very poor.

One of the best systems for keeping account of daily sales, etc., is the plan of the "Complete Business Register," published by H. W. Pamphilon, 30 Bond St., New York. It will pay enterprising jewelers to send for free sample page of this account book, and learn its advantages. The first of any month is a good time to commence using it.

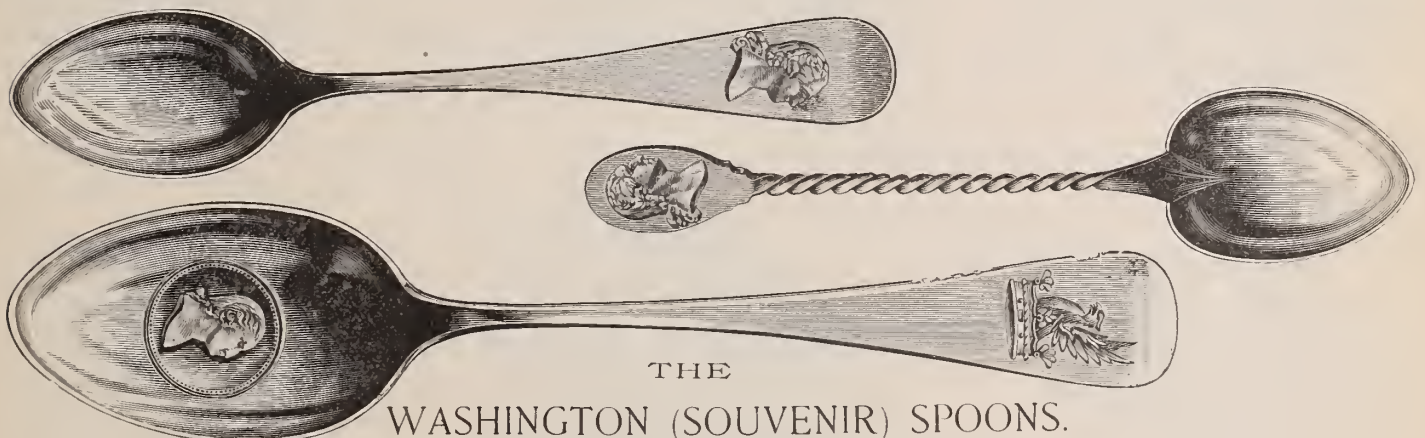

THE WASHINGTON (SOUVENIR) SPOONS.

REGISTERED TRADE MARK.

- 1st.—Full size Tea. Perfect likeness of the Father of his Country, in gilt bowl, with the Washington Crest on handle.
- 2d.—After Dinner Coffee, twist. Head on handle, plain or all gilt.
- 3d.—After Dinner Coffee, with head on handle.

As well as a varied assortment of other patterns.

DISCOUNT TO THE TRADE.

SEND FOR PRICE LIST.

M. W. GALT BRO. & CO., Jewelers,

1107 Penna. Ave., WASHINGTON, D. C

Providence.

L. W. Pierce, of L. W. Pierce & Co., has discharged a mortgage for \$3,900.

A. A. Remington is about to erect a two story and a half tenement house.

B. Graffam has purchased real estate of the Cranston Savings Bank for \$731.

M. Rosengarten, of Albany, N. Y., visited manufacturers in this vicinity the past week.

Jeremiah Briggs, of the J. Briggs & Sons Co., has returned from a winter's sojourn in the South.

J. C. Harrington & Son are closing out their business at 129 Eddy St., and expect to go out by May 1.

Richard Robinson, western traveler for Hancock, Becker & Co., was reported ill at Huntington, Ind., last week.

W. H. Crins, of the Gorham Mfg. Co., has been elected to membership in the Rhode Island Historical Society.

C. E. Child, of Warren, has been drawn as a juror to serve at the May term of the Court of Common Pleas of Bristol County.

Henry Tilden, of Tilden, Thurber & Co. sailed for Europe last week on the *Lahn*. This is his thirty-ninth trip across the ocean.

D. C. & H. S. Fink are contemplating extensive improvements by which they will greatly enlarge their store at 200 Westminister St.

The total value of the foreign importations

into this city last week was \$11,178, among which was one package of imitation stones from Havre.

Col. T. A. Barton has been appointed assistant inspector general to inspect the headquarters of the Connecticut division of the Sons of Veterans.

C. R. Smith was in Washington, D. C., the past week, in the interests of some of the recent inventions of the C. R. Smith Plating Co. on seamless wire.

Edwin Lowe received 5,667 votes as representative from the eighth ward of this city at the by-election on Friday, thereby obtaining a majority of 254.

The petition of B. W. Smith *et al.* to the General Assembly for an act to incorporate the Canonchet Jewelry Co., has been continued to the May session.

M. W. Morton, secretary of the Manufacturing Jewelry Board of Trade, was in Cleveland and Chicago last week on business connected with the Board.

Real estate belonging to Willard and J. E. Haskell, is advertised at mortgagee's sale, at 10 o'clock, April 21, 1891, under foreclosure of mortgage, dated April 4, 1873.

A. B. Morrison, doing business at Portland, Me., has creditors in this vicinity to the amount of \$800 or \$1,000. His total liabilities are about \$7,000, and his assets \$2,500.

C. E. Marcellus, of the McBride & Mar-

cellus Co., Cleveland, was in town the past week endeavoring to secure the sanction of the Providence creditors to the appointment of O. J. Campbell as trustee.

A. S. Southwick and W. K. Logee, doing business as A. S. Southwick & Co., have given a chattel mortgage to C. Hunt, of Connecticut, on the contents of their shop, on the fourth floor of 21 Eddy St., for \$3,500.

The request of Mrs. M. F. S. Smith, widow of A. J. Smith, for the appointment of an administrator of the estate of her late husband and for the appointment of a guardian for the minor children, will be acted upon in the Municipal Court at 9 A. M., April 21st.

Every jeweler knew Capt. Jesse Mott, and the news of his death was received with sorrow. Capt. Mott had been pilot and captain on the sound steamers since 1867, and the jewelers always felt a sense of safety on their New York trips when he was at the helm. He died April 8, at his home, Barnstable, Mass., aged 65 years.

The Hope Silver Mfg. Co. are a new firm to engage in the manufacture of jewelry at 195 Eddy St. in the shop formerly occupied by A. B. Day & Co. The firm is composed of W. F. Whiting, formerly foreman for Howard & Son Co. Emil Crecilus, for several years with the same firm, and Jerome Fitzgerald, son of Michael Fitzgerald, for whom he has been a traveling salesman for several seasons.



The most desirable line of 16-size movements on the market.

Chicago.

J. B. Beach, representing the Wilcox Silver Plate Co., was in town for several days on business.

The Richards Mfg. Co., Attleboro, Mass., are now regularly represented by J. H. Strong, who is well known to the trade of Chicago.

C. S. Raymond, Omaha, Neb., was in town during the past week examining fixtures for the new retail store, which he will open next fall.

Almost everyone in the trade has been in the toils of the grippe. Those that have not are speculating on the possibility of how soon they will be.

H. W. Henshaw, treasurer of the Geneva Optical Co., has just returned after a six weeks' absence at Lake Helen and Jacksonville, Fla., much improved in health.

F. W. Crempien, who will hereafter be direct representative for H. Muhr's Sons, of Philadelphia, Pa., is a young man of ability and is well liked by the trade.

L. I. Lake, of the American Watch Co., went to Cincinnati a week ago to assist Oskamp, Nolting & Co. on a supplementary catalogue on which they are to work.

H. F. Hahn is in St. Louis. Mr. Hahn is a firm believer in keeping in touch with his customers, and at least once a year he visits his customers at their own establishments.

C. K. Giles, of Giles, Bro. & Co., has just returned from a three weeks' outing at Biloxi, Miss. The fortnight's angling in the Gulf of Mexico has made him sunburnt and healthy.

H. M. Condit, Secretary of the N. Y. Jewelers' Board of Trade, was in this city during the week. Under the able guidance of M. N. Burchard, he visited the State St. trade on Thursday.

The friends of T. W. Duncan, general manager of the Elgin Watch Case Co., will be shocked to learn of his close call from the grippe. There was an improvement in his case during the past week.

The announcement of the failure of Sol. Bergman & Co., Omaha, Neb., which was received last Wednesday, did not seem to cause much surprise in this city. The local firms interested have not yet been made known.

The advent of pleasant sunny weather during the past few days, has done much to lift the gloom not only from the countenance, but from business as well. Commercially and financially there has been great improvement in this respect during the past week.

Col. J. J. Hoyt, treasurer and general manager of the Kenosha Watch Case Co., Kenoska, Wis., was in town last Wednesday. His company are about to put a handsome line of filled cases on the market. The event is celebrated by a beautiful new glass sign in an imitation oxidized silver frame. The "announcements" of the Kenoska Company will undoubtedly be in great demand

O. W. Wallis was in New Orleans at the time of the lynching of the "Italian Eleven." He and a friend were accompanied by a kodak. The result is that Mr. Wallis brings back some pictures of that memorable occasion that he feels very proud of.

H. S. Peck, who has been connected with the Waterbury Clock Co. for thirty years, and who lately resigned the charge of that concern's business in this city, has accepted a position with the Meriden Britannia Co., and will have charge of their hotel department in this city. At the meeting of the Chicago Jewelers' Association, Wednesday, Mr. Peck, who is a member, was the recipient of some very flattering resolutions to commemorate his long service with the Waterbury Co.

The Week's Arrivals.

The following out of town dealers were registered in New York during the current week: A. La France, Elmira, N. Y., Astor H.; A. Reid, Norwich, Conn., Murray Hill H.; A. Levy, Hamilton, Ont., Astor H.; T. Young, Wilson, N. C., St. Nicholas H.; A. Oppenheimer, Phila. Pa., Belvidere H.; J. L. Golden, Ogdensburg, N. Y., Sinclair H.; W. N. Whitney, Albany, N. Y., 338 Broadway.; S. and C. Gillespie, Sable Forks, N. Y., Sturtevant H.; J. J. Penn, Argyle, Pa., Metropolitan H.; J. B. Johnson, Baltimore, Md., Astor H.; L. M. Jones, Richmond, Ind., Bartholdi H.; M. H. Elbe, Niagara Falls, N. Y.; H. Horstmeyer, Schenectady, N. Y., 47 Leonard St.; C. E. Sumner, Cleveland, O., Oriental H.; T. Knight, Phila., Pa., St. Stephens H.; J. Brown, Boston, Mass., Occidental H.; U. P. Morse, Boston, Mass., Grand Union H.; F. M. Brown, New Haven Conn., 394 Broadway.; S. S. Vorrentur, Canandaigua, N. Y., Grand Central H., Mr. Parker, Bridgeport, Conn., Astor H.; Mr. Chance, Canton, O., Astor H.; M. Strifel, Ottawa, Ill., Belvedere H.; M. Scott, Floyd Ct. H., Va., Everett H.; B. F. Hall, Boston, Mass., Astor H.; D. Wilson, Neapolitan, O., Earles H.; G. Millhiser, Richmond, Va., Hoffman H.; A. M. Church, Troy, N.

Y., Metropolitan H.; G. E. Kirtland, Utica, N. Y., Continental H.; S. C. Lawrence, Boston, Mass., Windsor H.; S. C. Betes, Middleton, Pa., Continental H.; C. J. Winters, Jermyn, Pa., Earles H.; C. F. Dullard, Utica, N. Y., Continental H.; Mr. Yale, Gloversville, N. Y.; J. N. Mandelbaum, Hartford, Conn., Grand Union H.; and E. C. Atkinson, Philadelphia, Pa., Sinclair H.

BUY THE "BARON" SPECTACLE.



The best Periscopic Spectacle in the World for Opticians to sell for \$1.00. Sole Manufacturers, LEVY, DREYFUS & CO., 11 Maiden Lane, New York.

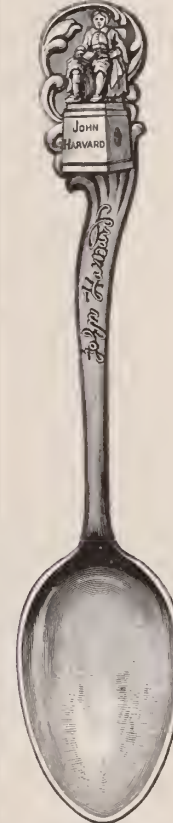

"John Harvard"

(Founder of Harvard University.)

SOUVENIR SPOON.

Harvard Men Everywhere.

The beauty of the design, the correct representation of the Statue of John Harvard, now standing in the College Campus, the Fac-simile of his Autograph and the superiority of the workmanship, make this the most popular Souvenir Spoon on the market.

In Sterling Silver Only.

Tea Spoon, Plain Bowls,	\$2.00 ea.
" " Gold "	2.50 "
Orange " Plain "	2.25 "
" " Gold "	2.50 "
Coffee " Plain "	1.25 "
" " Gold "	1.50 "

DISCOUNT TO THE TRADE.

FREEMAN & TAYLOR

Patent applied for. 495 Washington Street, BOSTON. Coffee Spoon (exact size.)

ALBERT S. GAGE.

H. A. WHEELER.

CHARLES C. HILTON.



The Wellington

OPENED SEPT., 1890,

As the Best Located, Furnished, Lighted, Ventilated and Equipped EUROPEAN HOTEL in the Country.

Provided with large Fire and Burglar-Proof Vault for Valuables. Steam and Electric Lighted throughout. Rates from \$1.50 to \$3.00 per day for rooms. Suites with baths from \$3.50 upwards. CUISINE UNEQUALLED.

GAGE HOTEL COMPANY, Proprietors,
Wabash Ave. and Jackson St., CHICAGO, ILL.

Connecticut.

A. B. Kingsbury, Norwich, is doing a large sale in souvenir spoons.

President Hiram Camp, of the New Haven Clock Co., quietly celebrated his 80th birthday last Tuesday.

Last evening C. D. Davis, of Parker & Davis, Bridgeport, was united in marriage to Miss Susan Hawley.

Gen. G. H. Ford, New Haven, has begun the alterations of the building in which his store is located. His special sale is well patronized.

Gold-bearing quartz has been discovered at Birmingham in the quarry now being operated by the Housatonic Water Co., for the repairing of the dam.

Three lively auction sales are in progress in New Haven, in the stores of C. G. Earle, Mrs. A. D. White and the Derby Silver Co. These stores close May 1st.

Hon. Samuel Simpson, Wallingford, who has been suffering with a severe attack of the grippe, is slowly gaining health, and hopes of his recovery are now becoming much brighter, despite his advanced years.

On April 8th G. E. Buckingham and E. F. Leonard, assistants in the store of W. V. Blair, Meriden, opened a jewelry business for themselves at 48 E. Main St., that town, under the name of Buckingham & Leonard.

Milwaukee.

James Gilowsky, is sojourning at Mt. Clemens, Mich.

H. Jacobson, Hurley, Wis., was in the city last week buying goods.

Julius Kahn, 200 Grand Ave., was married at Iron Mountain, Mich., to Miss Anna Levy, of the latter place, on Sunday.

J. C. Ludwig, who was defeated for Judge of the County Superior Court, Tuesday, was formerly connected with a Mr. Cogswell in the jewelry business in this city.

Bunde & Upmeyer have converted their old clock ante-room into an elaborately furnished art-room, its dimensions being increased somewhat by encroaching a little on the manufacturing department, a portion of the latter being now located in the basement.

The O. L. Rosenkrans & Thatcher Co. will move to their new store, 129 Wisconsin St., next week. In the meantime a portion of the old stock is being disposed of at auction at the old location. The new store is located a block and a half farther east than the old one, and will be in many ways an improvement, although it is not so centrally located.

Indianapolis.

A. P. Craft and Emil Koehler have formed a partnership, and advertise themselves as diamond setters, engravers and jewelers.

Frank Johns, formerly in the employ of W. T. Marcy, but now with J. C. Herkner,

Grand Rapids, Mich., was married here, last week, to Miss Rosa Aldrich.

G. G. Dyer, of W. T. Marcy, is designing a unique set of souvenir spoons, on the order of a customer. They are to relate to Indiana subjects, and be entirely original.

Julius Walk, of Bingham & Walk, left Friday for Providence, R. I., to have a die made for his Soldiers' Monument spoon, the right to manufacture which he controls.

Rochester.

R. M. Hodgson is the only jeweler on the Board of Education, which was organized last week.

Ground has been broken for a new factory for the Gundlach Optical Co., on Pinnacle Ave. The building will be two stories and basement, and 32x100 feet in dimensions.

Charles Robie, of this city, has bought the store of W. J. Kerr, Jr., at Olean, this State, and is enlarging the stock. Mr. Kerr may establish another store at Bradford, Pa., but has not yet determined his future movements.

San Francisco.

The local journals are highly complimenting Johnson & Paulsen, East Oakland, upon the beauty of their store.

J. C. Fitzpatrick, a watchmaker and jeweler in Oakland, has been arrested on a charge of embezzling two watches left with him for repair.

William Robbins, a watchmaker and jeweler, formerly of Eureka, this State, has engaged in business for himself in this city. His new quarters are in the Phelan Building.

Trade continues to improve. The trade in souvenir spoons has become so lively that everyone is kept busy, and as a consequence the demand for these goods has increased the sales in other lines.

A mysterious affair took place the other night at the store of Cummings & Sons, 327 Kearney St. After the clerks had closed the store, a woman was seen to rush through the doors and out on to the sidewalk, closely pursued by three young men, who caught her before she had gone five steps from the store. Two of the young men pinioned her arms while the third wrenched from her hand something which to many of the spectators resembled a revolver, while to others it looked like an article of jewelry. The three men then dragged the woman back into the store and after closing the doors locked them. The lights were extinguished, and sometime later all the parties took a carriage at the back door and disappeared. The police have failed to solve the mystery.

The masonic jewels recently discovered in the woods near Ellijay, Ga., and which created considerable excitement at that place, are now learned to have been stolen from the old Masonic lodge in that town, during the Rebellion.



The Jewelers' School of Engraving, at 63 to 69 Washington St., Chicago, Ill., is in a most flourishing state these days. There are twenty students under the care and supervision of Prof. Kendler, who has now had charge of this useful branch of instruction to the trade for three years, and whose ability is apparent from the proficiency of his pupils. The graduates are in much demand all over the country, and command an excellent salary.

The Geneva Optical Co., 23 Washington St., Chicago, Ill., during the past week received orders for their lens measure from England, Germany, France and Austria.

This little instrument is proving itself to be of inestimable worth to opticians all over the world.

Among the first-class hotels in Chicago, Ill., probably none are entitled to that claim in a greater degree than the Wellington, centrally located on Wabash ave. Its appointments throughout excite the astonishment of its guests. No wonder that the great traveling public, who are looking for comfort, turn their eyes towards its hospitable doors. The jewelers, both principals and representatives, will find that the proprietors of this superb hostelry will extend to them the right hand of fellowship and make their sojourn, while in Chicago, very comfortable at the Wellington. That veteran boniface, Charles Hilton, presides as manager, which is a sure guarantee of every liberality being extended the trade.

One of the best selling spectacles is the Baron, manufactured by Levy, Dreyfus & Co., 11 Maiden Lane, New York. It sells for \$1.00 and possesses a well-tempered frame and large clear lenses. The Baron is made uniform in size and quality.

The Wendell Mfg. Co., 218 Washington St., Chicago, Ill., established in 1890, with all new and improved machinery, are now employing sixty hands. The company make a specialty of etching names of city, buildings, scenes, statues, objects of interest, etc., in bowls, of their Windsor engraved tea, coffee and orange spoon. The etching is done with acids, leaves the objects raised in relief, and has a very beautiful effect. The company employ several artists, and are very prompt in getting out special work; no order remains in the factory over one week. This company caters for the medium class of trade, and makes special efforts to meet their requirements.

Mr. Nolting, of Oskamp, Nolting & Co., Cincinnati, O., says that his firm propose to inaugurate a new proceeding with the trade; they will give to the best guesser (the plan will be evolved in their new catalogue that will come out shortly,) a fine imported marble clock with one of their handsomest bronze figures.

G. C. Shreve & Co., San Francisco, Cal., have placed upon the market a new line of watches, two sizes for gentlemen and three sizes for ladies.

Drake & Smith, manufacturers of jewelers' mailing boxes, Bristol, N. Y., are employing twenty-three people and have orders enough to keep them running on full time for three months.

A. G. Schwab, Cincinnati, O., says there has been an unusual demand for heart-shaped jewelry this season. Some of the pendants he has in stock are beautiful enough to capture any feminine heart, from the tiny necklace charm to the large ones worn on the victorias.

Homan & Co., Cincinnati, O., are still producing new and handsome designs in silver plated goods. Fruit dishes and stands in various patterns invite a favorable comparison to sterling ware. The individual butters, gold lined, are among the artistic pieces that will be much sought after for presents.

O. W. Bullock & Co., Springfield, Mass., report that they had a fine trade during March. This firm are getting out several new patent tools to keep abreast of the demand for labor-saving devices from watch repairers and others. They find that their efforts in making good tools are well appreciated by the consumers, especially by those who have heretofore had to use cheap foreign imitations.

Gustave Fox & Co., Cincinnati, O., are showing a novelty in gem ring cases that has brightened up their trade considerably. The case is of morocco, satin lined, with velvet grooves, each containing a ring for each calendar month. The name of the stone and month are printed on a celluloid card next to the ring. The mountings may be of twisted wire or enameled band. Lee Kaufman has just returned from a trip, and said if it had not been for this novelty, his trade would have been slim.

Duhme & Co., Cincinnati, O., when they began to make some of the aluminum spoons, thought the fad would be short lived, but they are constantly besieged for them. They do not care to make large quantities, as that would interfere with their regular factory work, and they would rather sell their solid silver in which there is more profit. A singular order was received last week for a set of aluminum spoons in a handsome plush case for a wedding present. There is no telling where this fancy will end.

Patek, Philippe & Co., of Geneva, Switzerland, the makers of the celebrated watch bearing their name, have been very successful since their recent "re-organization" in taking the first prize at the Competition of Fine Watches at the Geneva Astronomical Observatory. Several other prizes and honorable mentions were awarded to them by the judges for special and general merits of the watches manufactured by them. We are glad to witness the energy displayed by this old established firm in keeping their position in the front rank of fine watch manufacturers.

KREMENTZ & Co.,

182 & 184 Broadway, NEW YORK,

MANUFACTURERS OF

GOLD JEWELRY,

14-K. BEAD NECKLACES,

— AND —

KREMENTZ ONE-PIECE COLLAR BUTTONS.

Our line, composed of



*Chain Mountings, Chains, Neck Chains,
Crosses, Bead Necks, Bracelets, Bangles,
Earrings, Glove Buttoners, Garters,
Locketts and Charms, "Mount Hope" Buttons,
Initial Scarf Pins, Bar Pins, Cuff Pins, Jersey Pins,*

is of high grade rolled plate, and as a guarantee that they will wear well we stamp them **F. & B.**

Our sleeve button is the "Mount Hope" and is the best in the world.



W. ROSENTALL,
79 NASSAU ST., N. Y.

Manufacturer of

Silk Vest Chains.

with



GOLD & SILVER

PLATED & OXIDIZED SLIDES.

LEON J. GLAENZER & CO.,

80 CHAMBERS STREET

35 Boulevard de Strasburg.
PARIS.

NEW YORK.

OUR SPECIALTIES:

Clocks, Porcelains, Faiences, Bronzes

We have now on exhibition and are constantly receiving large shipments of the latest novelties in **Onyx and Marble Clocks**, with Gilt and Enamelled Trimmings, **Regulators, Traveling Clocks, Porcelain and Gilt Mounted Clock Sets, Vases, Candelabras, etc.**, which we are offering at Lowest Prices.

Our stock also comprises a large assortment of **Porcelains, Faiences, Bronzes, Gilt and Silver Photo Frames, Jewel Boxes, Bonbonnieres, Mirrors** etc., suitable for the jewelry trade.

SPECIAL INDUCEMENTS ON IMPORT ORDERS.

Recent Patents

Issue of April 7, 1891.

DESIGN NO. **20,664**. HANDLE FOR SPOONS, ETC. GEORGE GOODING and BENJAMIN W. GOODING, Plymouth, Mass.—Application filed January 17, 1891. Serial No. 378,162. Term of patent 14 years.

DESIGN NO. **20,665**. SPOON. ERWIN C. BAUMGRAS, Washington, D. C.—Application filed March 14, 1891. Serial No. 385,133. Term of patent 3½ years.

DESIGN NO. **20,666**. SPOON. ALICE J. DEMPSEY, Washington, D. C.—Application filed March 14, 1891. Serial No. 385,134. Term of patent 7 years.

DESIGN NO. **20,667**. SUGAR-BOWL, ETC. GILBERT L. CROWELL, JR., Arlington, N. J., assignor to Dominick & Haff, New York, N. Y.—Application filed March 16, 1891. Serial No. 385,330. Term of patent 7 years.

DESIGN NO. **20,668**. SPOON, ETC. JOHN H. JOHNSTON, New York, N. Y.—Application filed March 16, 1891. Serial No. 385,286. Term of patent 7 years.

TRADE MARK NO. **19,283**. VEST-CHAINS. D. C. PERCIVAL & Co., Boston, Mass.—Application filed January 14, 1891. Used since December 29, 1890.

"The word 'BOSTON' preceded by a star."

TRADE MARK NO. **19,284**. IMITATION DIAMONDS. D. C. PERCIVAL & Co., Boston, Mass.—Application filed January 14, 1891. Used since January, 1889.

"The word 'PAOLA.'"

449,885. WATCH-BOW FASTENER. CHARLES F. MORRILL, Boston, Mass.—Filed May 21, 1890. Serial No. 352,582. (No model.)

The combination, with the watch-case pendant having the sockets for the reception of the bow ends and longitudinal pin-openings extending in from the top and intersecting the sockets, the bow having the

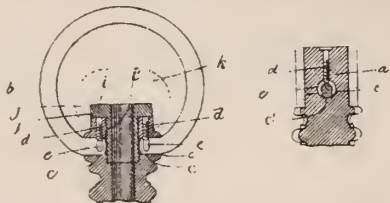

grooved ends within the sockets and the pins in the longitudinal opening entering the grooves, of the cap overlying the pins and having the screw-thread stem screwing into the pendant, this cap being adapted to be covered by the crown.

449,915. STOP-WATCH. LOUIS E. PIQUET, Brassus, Switzerland.—Filed Oct. 8, 1890. Serial No. 367,419. (No model.) Patented in Switzerland Dec. 31, 1888, No. 235.

In a stop-watch mechanism, the combination, with the independent seconds-hand and arbor, of a gear-wheel upon the arbor adapted to receive a lateral

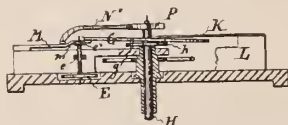

movement at one side of its periphery, a spring to restore the wheel to its normal position and bring it into gear with the continuously-rotating pinion of the time-train, a heart-cam upon the arbor of the independent seconds-hand, a spring-arm capable of separating the gear-wheel from the continuously-rotating pinion, and a lever acted upon by the cam or star wheel of the

stop-watch and having two arms acting in opposite directions, one to restore the independent seconds-hand to its normal position by acting upon the heart-cam, and the other to move the spring-arm away from the gear-wheel and allow the same to engage the teeth of the pinion.

449,890. APPARATUS FOR ELECTROPLATING SMALL ARTICLES. FREDERICK W. ZINGSEM, N. Y.—Filed Oct. 17, 1890. Serial No. 368,482. (No Model.)

An apparatus for electroplating small articles, composed of a solution-tank, a shaft supported in conductive bearings of the tank, a rotary reticulated drum of non-conductive material attached to the shaft, a con-

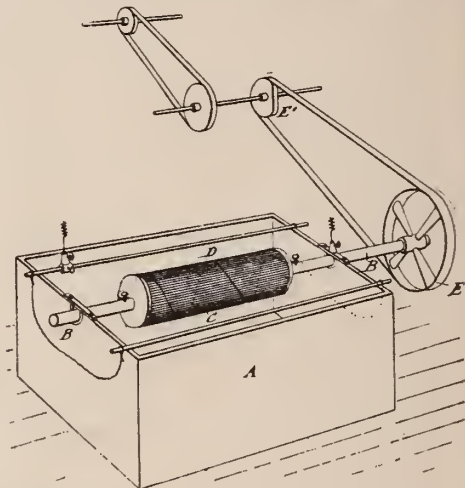

ducting-wire extending spirally through the drum, and mechanism for imparting intermittent rotary motion to the drum, so that the plating action is accomplished mainly during the periods of rest of the drum.



RAH! RAH!! RAH!!!
THE RECORD BROKEN.

More Lathes sold in March than in any previous month.

- 1 No. 1 WHITCOMB.
- 30 No. 1½ WHITCOMB.
- 51 No. 1½ WEBSTER-WHITCOMB.
- 1 No. 2 WHITCOMB.

83 IN ALL.

AMERICAN WATCH TOOL CO.,

Stony Batter Works, WALTHAM, MASS.



A Lady's Ramble Among the Jewelers.

Silver anchors are used to secure leather belts.

Chatelaines with many appendages remain with us.

Russia leather belts with silver monograms are in vogue.

Square lockets with chased borders and diamond centres are popular.

Old fashioned brass candle snuffers and snuffer trays are reproduced in silver.

Some of the French gilt clocks have the dial set in a frame work of Rhine stones.

A pretty brooch represents a cluster of grapes with pearls, the leaves and tendrils being of gold.

Admirers of the old style satin finish will be pleased with silver trays in satin finish with embossed borders.

Diamond brooches, in which the gems merely outline a heart, afford a change from the solid heart brooches.

Silver asparagus servers, richly chased and pierced, are seasonable, as are individual asparagus tongs in designs to match the servers.

A necklace much admired is formed of three strands of gold chain, which are caught in festoons and held in place with little rosettes of pearls.

Ladies like the cluster earrings; these are small, and the usual arrangement is a fine colored gem in the centre, with tiny but fine diamonds encircling it.

There are some exceedingly pretty brooches in grape jewelry, such as a cluster of dark purple grapes laid against a broad green leaf. These come in both gold and silver.

Gold glove buttoners that fold inside a case, after the fashion of a pocket knife, are carried by ladies inside of card cases or purses and by men in the waistcoat pocket.

Lovers of bizarre effects are pleased with clocks, the dials of which are set in the body of a bronze lion which thrusts out an abnormally red tongue and wags its tail at the beat of every second.

The bouquet holder in silver or electroplate for carriages, is of English origin. It is constructed to fasten in a small socket that is screwed to one of the front panels of the carriage. The slant of the holder is such as to throw the flowers forward, thereby protecting them from being crushed on the way to the church wedding, or theatre or other entertainment.

ELSIE BEE.

OPPENHEIMER BROS. & VEITH,
 Watches, Diamonds and Jewelry,
 2 Tulp Straat, 35 Maiden Lane,
 AMSTERDAM. NEW YORK.

SPECIALTY:

Recognizing the demand for

HAMPDEN MOVEMENTS and DUEBER CASES,

We have made a Specialty of these lines of goods and carry a large stock of same.

HAYDEN W. WHEELER & CO.,

2 MAIDEN LANE, NEW YORK,

Have an unusually large and varied stock of

FANCY STONE RINGS,

CONSISTING OF

MOONSTONE, GARNET, TOPAZ, AMETHYST, PERIDOT,
 PEARL, DOUBLET, SARDONYX,

And the various combinations of these Stones.

DIAMONDS, WATCHES, JEWELRY.

WANTED, AN ADVERTISEMENT.

I will pay Fifty Dollars in cash to the Retail Jeweler who shall prepare the best worded and most effectively displayed advertisement of *Abbott's Patent Stem-Winding Attachment*, suitable for use in Magazines and Newspapers that reach the general public.

The advertisement to occupy a space of not more than two inches high by five inches wide.

The contest will close May 1st, 1891, and the prize will be awarded within ten days from that date.

**I WILL PAY
 FIFTY
 DOLLARS
 IN CASH**

The following gentlemen will act as judges:

Mr. L. J. MULFORD,
Of The Jewelers' Circular.

Mr. ALBERT ULMANN,
Of The Jewelers' Weekly.

Mr. JOHN L. SHEPHERD,
Of The Keystone.

Circulars and descriptive matter supplied on application.

HENRY ABBOTT,

After May 1st, 14 Maiden Lane.

4 Maiden Lane, N. Y.

ARE YOU DISSOLVING PARTNERSHIP
 ARE YOU HAVING DULL TRADE
 ARE YOU ABOUT TO RETIRE
 ARE YOU OVERSTOCKED
 ARE YOU REMOVING

IF YOU ARE, COMMUNICATE WITH

A. J. COMRIE,
 AUCTIONEER,

Specialty of Jewelers' Sales.

16 West 125th St., New York.

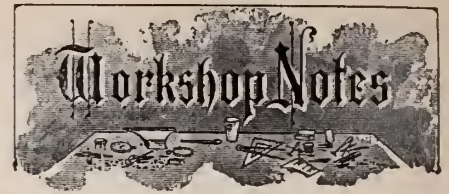

To Remove Lead-solder.—Place the piece of jewelry in muriatic acid, and leave it till the lead is eaten away. It is always best to heat the piece gently and brush off the lead, while melted, before subjecting the piece to the action of the acid.

Gilding on Marble.—To gild on marble, mix white lead to a proper consistency with fat oil, and then with turps; paint the portion to be gilded with the mixture, afterwards sizing with japanner's gold size, and when it is dry applying the gold leaf, the best material being employed.

Knife Suspension.—If a very exact rate is expected from a knife suspension of the pendulum, it stands to reason that neither in the polished edge nor in the pan the least rust must be visible, and the only way to prevent it is by slightly oiling the parts. This is especially true of steeple clocks, since they are very much exposed to the action of the atmosphere.

Ink for Etching on Glass.—An ink, or writing fluid, that can be used for etching directly on glass, may be made from the following ingredients, which are kept separate until the ink is required for use: A solution of ammonium fluoride, some sulphate of baryta, and sulphuric acid. When required, a portion of the sulphate of baryta is moistened with the fluoride solution, a few drops of the sulphuric acid are stirred into the mixture, and the thin fluid paste is at once applied to the glass with a pen, with which the desired characters are written. The etching will be found to be sufficiently legible after the ink has remained on the glass for an hour. This preparation will corrode steel pens, but otherwise is free from objections.

Removing Broken Screws From Watch Plates, etc.—A correspondent of THE CIRCULAR, complains that he has had a bad case of broken screw in a watch plate, and wants to know how to get it out. With a screw-head file cut a slit in the top of the broken screw, deep enough for a screw-driver to have a firm hold. Then pressing the screw-driver firmly in the slit, turn it to the left, and in most cases the screw will give way. After turning it once or twice, it is advisable to file off the top of the screw nearly level with the watch plate, and recut the slit. If this method does not answer, place the plate with the top of the broken screw over one of the holes in the riveting stake, corresponding to the size of the screw, and with a joint pusher placed on the bottom of the screw, give a sharp blow with a hammer or mallet, which generally breaks the head and partly drives it through the plate, after which it can be pulled out with a pair of pliers. Retap the hole and fit in a new screw.



Geneva Optical Co.,
 MANUFACTURERS OF
 Spectacles, Eye
 Glasses, Lenses
 and Cases.
 23 WASHINGTON ST.,
 CHICAGO.

The Highest Grade
 — OF —
 Electro Silver
 Plated Ware

Is Stamped with the
 **ROGERS TRADE-MARKS.**
 MANUFACTURED BY
The Wm. Rogers Manufacturing Co.,
 P. O. DRAWER 30,
 HARTFORD, - CONN.



UNITED STATES OPTICAL CO.

15 Grand River Ave., Detroit, Mich

Manufacturers and Jobbers of

Spectacles and Eye Glasses.

Special Attention given to Prescription Work, and Repairing by Skilled Workmen.

Our facilities for the manufacture of **SPECTACLES** and **EYE GLASS CASES** are such that we can quote lowest prices.

WILL FURNISH SAMPLES ON APPLICATION



To Make a Barrel Arbor.

WHEN the ratchet has been cut in, work is commenced by turning the large shoulder for the bridge, then making the ratchet thinner and reducing the upper pivot for the winding square to its proper size; the large pivot for the barrel is then turned, the thread for the core tapped on, or, if it belongs to the old system with a pin, the core is fitted on and its hole drilled through. While the barrel arbor is still safe, turn on the upper pivot, grind all the pivots in a depthing tool arranged for the purpose and fit them in thus so that they enter their holes with tight friction. Then mark out how long the square for the snale stop is to be, turn a small brass shell upon the pivot, making it of equal length, so as to protect it during the filing, and file on the square.

File on the winding square, by protecting the ratchet with a small piece of thin sheet steel (a piece of steel of a pendulum suspension is good for this purpose) which, being of the size of the ratchet, is laid under with a hole in the center. Grind both squares flat in the lathe between the centres and then drill the hole for the snale stop; when fitting the pivots into the holes, carefully remove all the sharp burr, as it would wear the holes.

Then turn grooves on both sides of the arbor at the places where it is to be shortened, but not too deep, so that the pieces can break off of themselves. This is done in case of its drawing out of shape in tempering, to have a more convenient way of straightening and also to make the winding square as hard as possible.

In order to temper the barrel arbor, it may

be placed in an iron box with charcoal and bone-black, throwing the whole, when at glow-heat, into water; it may also be laid free upon a slightly hollowed out coal, and covered with one, taking care not to let the pointed flame operate direct upon it; it is then annealed blue, and should it have become warped, make round by filing at the ends. The front side as well as the other shoulders, can be ground and polished in the afore-described depthing tool, or else with a flat piece of sheet iron, with a hole in the centre a little larger than the square, and which is used as a face polisher. The sharp edge of the teeth chamfered a trifle, and polished with a slightly hollowed-out funnel shape piece of sheet iron.

I think it is better than ever in the weekly form.

R. V. Hurd.

BIPPART & CO.,

Newark, N. J.



INTERIOR VIEWS OF
FACTORY.

Manufacturers of
FINE JEWELRY.

A Remington Standard Typewriter

Will Economize Time, Reduce Labor, Preserve Health, Save Money, Prevent Errors.

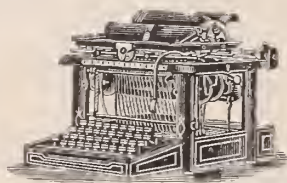

SEND FOR ILLUSTRATED CATALOGUE.

Wyckoff, Seamans & Benedict,
327 Broadway, New York.

G. F. FEINIER,
MANUFACTURER OF
WATCH CASES,
Repairing of Every Description,
NO. 9 BOND STREET, NEW YORK.
Key-Wind Cases Altered to Stem-Wind, and made same as New. English Cases Altered to take American Movements.

Jules Jürgensen
OF COPENHAGEN.

The reputation these watches have maintained for **Fifty Years** has never been equaled, being made on strictly scientific principles, and no expense spared to give the **Best** results in mechanism and timekeeping qualities.

SOLE AGENTS,

John C. Hyde's Sons,
NO. 22 MAIDEN LANE.

H. H. HEINRICH,
12, 14 & 16 John St., New York.
Manufacturer of
MARINE CHRONOMETERS.

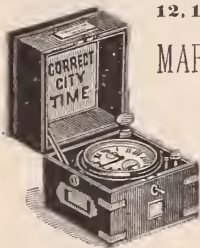

Silver Medal, Paris Exhibition, 1889.
A large stock of new and second-hand Marine Chronometers on hand. All my second-hand Chronometers are thoroughly overhauled, refinished and re-adjusted. Rented out at \$5.00 per month, payable in advance. No rent charged if bought within a certain time. Terms to suit customers. Marine Chronometers repaired and adjusted for the trade.

SWARTCHILD & CO.,



Our Complete Catalogue, illustrated, will be sent to any one forwarding us their address, free of charge.

We give special attention to mail orders. They are filled promptly the same day that they are received.

76 and 78 State Street, Chicago.

Chicago College of Horology,

SUCCESSORS TO

THE CHICAGO HOROLOGICAL INSTITUTE,

IS ACKNOWLEDGED by those who have investigated the subject to be a

FIRST-CLASS INSTITUTION,

Where those who desire to learn the art of **WATCH MAKING** and **ENGRAVING** can obtain the

BEST PRACTICAL INSTRUCTION.

New features are continually being added. It is the aim of those conducting the management of the College to make it the

BEST INSTITUTION of the kind **IN THE COUNTRY.**

C. R. HART, General Superintendent,

CHICAGO COLLEGE OF HOROLOGY,

CHICAGO, ILL.

WRITE FOR PROSPECTUS.

VACHERON & CONSTANTIN,
GENEVA, SWITZERLAND.



FINEST QUALITY OF WATCH MOVEMENTS, FITTING ALL SIZES OF AMERICAN CASES.



CHAS. LEO ABRY,

Agent for the United States and Canada.

41 and 43 Maiden Lane, - - - NEW YORK.

A Complete History of Watch and Clock Making in America.*

BY CHAS. S. CROSSMAN.

Number Fifty-four.

Continued from page 49, April 1.

SETH THOMAS CLOCK CO., AND SETH THOMAS SONS' CLOCK CO.

ALTHOUGH existing as an organized company since 1853, the above concerns date their origin back to 1811. At that time Seth Thomas and Silas Hoadley, two journeymen, were employed by Eli Terry, manufacturer of wooden hanging clocks; they subsequently bought out their employer's business, and located in the southeast part of Plymouth, Mass., now known as Hancock Station, on the N. Y. & N. E. R. R. They continued the business in the same location



SETH THOMAS.

for two years, when they concluded to separate, Mr. Hoadley giving Mr. Thomas \$4,000 for his share in the business. With this sum Mr. Thomas went to Plymouth Hollow, now Thomaston, Conn., and purchased the clock factory of Heman Clark, who had been making high brass clocks in a small way. The building was located on the Northfield branch of the Naugatuck River, where the Seth Thomas Co.'s case factory now stands. Mr. Thomas also built a small factory in addition to the one purchased, and began manufacturing wooden clocks on his own account, and he bought from Mr. Terry the right to make his patent shelf clock, which the latter had just invented. This clock was destined soon to supersede all others. He paid \$1,000 for the right, which at that time was considered a large sum. The clock immediately became very popular, and Mr. Thomas increased his facilities for manufacturing to the extent of six thousand clocks per year. They sold at \$15 each, and the manufacturer realized a snug fortune from their sale. It held almost undisputed sway until the invention of Chauncey Jerome's "Bronze looking glass clock," in 1825.

Mr. Thomas soon turned his attention to this clock, beginning to manufacture it in a

*Copyright 1885, by C. S. Crossman.

DIAMONDS.

Wm. S. Hedges & Co.,
Importers of Diamonds,

And Manufacturers of DIAMOND JEWELRY,
No. 170 BROADWAY,
S. E. Cor. Maiden Lane, } New York.
27 Holborn Viaduct, London.

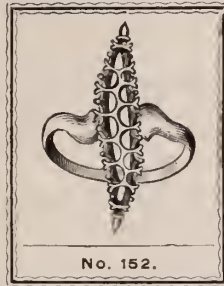

“S”

A “NOVELTY” in Marquis Rings.

ASK YOUR JOBBER FOR

STERN BROTHERS' DIAMOND MOUNTINGS,

42 MAIDEN LANE, N. Y.

MAXHEIMER & BERESFORD,

MANUFACTURERS OF

FINE DIAMOND JEWELRY,

No. 3 Maiden Lane, New York.

ORDER WORK A SPECIALTY.

WILL REMOVE APRIL 15, TO
189 BROADWAY.

R. A. Kipling

Importer of Precious Stones

31, Union Square
New-York

19, Rue Drouot
Paris

TO THE TRADE ONLY.

Balance Staffs, - 60 Cents.
Inserting Pivots, 40 Cents.

ALL OTHER WORK IN PROPORTION.

SEND FOR PRICE LIST.

THOMAS JUZEK & CO.,
ELGIN, ILL.

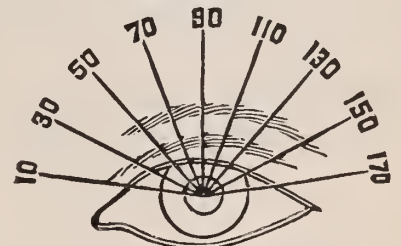

SEND TO

GENEVA OPTICAL CO.

23 Washington St., Chicago.

FOR PRESCRIPTIONS, REPAIR AND ORDER WORK
PROMPTLY AT LOWEST PRICES.

SEXTON BROS. & WASHBURN,

41 MAIDEN LANE, NEW YORK,

MANUFACTURERS OF

FINE JEWELRY,

INCLUDING A FULL LINE OF MOUNTINGS.



PROMPT AND CAREFUL ATTENTION GIVEN TO SPECIAL ORDER WORK.

A. N. CLARK, PLAINVILLE, } MANUFACTURER of the Celebrated
CONN. }

LOOP WATCH KEY.

The best for the price in the World. Size
of Square stamped on each Key.

Also Key Rings, Watch Case Springs,
Jewelry Tools, Tweezers, Etc.



SEND FOR PRICE
LIST.

SOLD BY ALL JOBBERS IN THE LINE
AT MANUFACTURER'S PRICES.

BURDON'S SEAMLESS.

THE ORIGINAL
And only Genuine



AND
Perfect Seamless Filled Wires
IN THE WORLD.
Sold to all Manufacturers
alike.

Burdon Seamless Wire.

TRADE-MARK.

The success of the BURDON SEAMLESS FILLED WIRE, like that of all important inventions, has been followed by deceptive and imperfect imitations. For the protection of

ALL JOBBERS AND RETAILERS,

we authorize manufacturers who so desire, to affix upon the tag, card or label accompanying the articles made from this wire, this registered trade-mark owned by this Company.

The bird-on-wire is a guarantee that the goods are made from the original Burdon Seamless Filled Wire, the reputation of which has been firmly established among the best dealers for more than two years. The perfection and qualities of the Burdon Seamless Wires are always guaranteed. All Dealers (jobbers and retailers alike) should, therefore, demand goods made from the original Burdon Wire, and avoid imitations which are offered as "just as good."

BURDON SEAMLESS FILLED WIRE CO.,
109 to 119 and 127 Summer Street,
PROVIDENCE, R. I.

TELL A. BEGUELIN,
IMPORTER OF
WATCHES,

Watch Materials, Tools and Glasses,
No. 71 NASSAU STREET,
(UP STAIRS.) NEW YORK.

Cor. John Street,
Sole Importer of Material for the
"Bijou," "Victor," "Boston," "Bristol,"
"Adelphia," "Jockey Club," "Wallingford,"
"Cæsar," "Lady Racine" and "New Haven"
Watches

Selling Agent for materials for LONGINES
and AGASSIZ Watches.
AMERICAN WATCHES,
ALSO STEM WIND WHEELS
Importer of Full Line of Swiss Watches,
AND FRENCH CLOCK GLASSES.

S. COTTLE & CO.,
MAKERS OF
FINE JEWELRY AND SILVER
NOVELTIES,
No. 86o Broadway, NEW YORK.

ARTIFICIAL EYES!

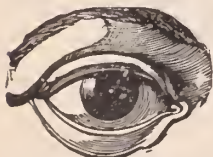

STOCK ORDERS of
Selection Packages.

Largest Assortment.

GENEVA OPTICAL CO.,
23 Washington St., Chicago.

R. & L. FRIEDLANDER,

Wholesale Jewelers,

AND

JOBBERS IN AMERICAN WATCHES,

Tools, Materials and Optical Goods,

65 & 67 NASSAU STREET, N. Y.

Factory, 50 BOND STREET.

Send Business Card and we will mail you our Watch and Jewelry Catalogue,
No. 12, and our Tool, Material and Optical Catalogue, No. 14.

READ THIS LETTER:

HENRY ERBSMEHL,

Watchmaker & Jeweler,

Watches, Clocks, Jewelry and Silverware.

MILFORD, DEL., March 4th, 1891.

MESSRS. R. & L. FRIEDLANDER, New York City.

GENTLEMEN: It gives me pleasure to recommend to the trade your Monarch Main Springs, for American Watches. They are, without exception, the best Main Springs that I have ever used. I have tried all makes within the last 25 years, but have found none equal to the Monarch Springs. They are uniform in force and temper; out of 6 dozen springs, I have lost but two.

I remain, yours truly,

HENRY ERBSMEHL.

Try our Monarch American Main Springs, \$12.00 PER GROSS.
\$1.00 PER DOZEN
POSITIVELY NO GOODS SOLD AT RETAIL.

Established 1872.

PLAINVILLE STOCK CO.



BROOCHES, SCARF PINS, DROPS, SETS.

FACTORY AT PLAINVILLE, MASS.

SAMPLES AT 176 BROADWAY, NEW YORK

DIAMOND SETTINGS.

GALLERIES.

HOLLOW BALLS, ETC.

BLANCARD & CO.,

36 & 38 JOHN STREET,

SEND FOR OUR

NEW YORK.

CATALOGUE.

MUSICAL JACOT & SON,
298 Broadway,
New York

Send for Catalogue.

BOXES.

Musical Boxes Repaired.

GILBERT T. WOGLOM,

BLACK JEWELRY. ONYX
MAKER OF Pearl Ornamented and Plain
GOLD MOUNTED.

32 & 34 John St. New York City.

THE WALTHAM SCHOOL OF HOROLOGY,

D. D. PALMER, Teacher and Proprietor.

Best Advantages in the Country for Horological Instruction.

All branches under the personal supervision of D. D. PALMER, for a number of years in charge of the Adjusting Department of the Waltham Watch Co. POSITIONS GUARANTEED TO APT PUPILS. For terms and other particulars, address

D. D. PALMER,
WALTHAM, MASS.

Specialty of Difficult Repair Jobs.



small way, but eventually almost entirely. They cost one dollar less to make and sold for two dollars more than the Terry shelf clock, which in its improved form was called the Pillar scroll-top case.

In the meantime Mr. Thomas had been in a lengthy litigation with Eli Terry. It seems that in 1816, when Mr. Terry invented the improved shelf clock which was the Pillar scroll-top case just alluded to, he claimed the exclusive right to manufacture it, while Mr. Thomas, who had bought the right to manufacture the original shelf clock, also claimed the privilege of manufacturing it in its improved form. The litigation commenced by Mr. Terry lasted for twelve or fifteen years, but finally the suits were tried in Hartford and New Haven in 1824, a four horse wagon placarded "Injunction," and filled with witnesses, mostly employes of Mr. Thomas, being sent over from Plymouth Hollow for the trial. The suits dragged on and the case was finally withdrawn from the courts without a final settlement.

In 1825 Mr. Thomas built an addition to the factory which nearly doubled its size; this forms part of the first case shop of the present Seth Thomas Clock Co. The year 1830 finds him making the Pillar scroll clocks and looking-glass clocks at the rate of six thousand per annum and employing about fifty hands, with the business in a very prosperous condition. In 1831 he built a large cotton factory for manufacturing heavy sheetings; it was four and a half stories high and was run in connection with the clock business until the time of the Rebellion, when it was closed and was never opened again as a cotton factory. On March 31, 1853, he organized the Seth Thomas Clock Co., under the joint stock laws of Connecticut, with a capital of \$75,000, with himself as president and his brother Edward Thomas as secretary and treasurer.

In 1855 the company started a brass manufacturing business as a separate corporate company under the title of the Thomas Mfg. Co. The brass mill was totally destroyed by fire during the same year, but was rebuilt in 1857. A Waterbury company bought a controlling interest in it in 1860 and the business was increased to its present large dimensions. The infirmities of age were fast coming upon Mr. Thomas, and on Jan. 20, 1859, he died. At this point a few lines of biography may not be amiss. Seth Thomas was born in Wolcot, Conn., Aug. 19, 1785. He had but meagre educational advantages, being obliged to content himself with those offered by a free day school. He served an apprenticeship as a carpenter before entering the clock business and spent considerable time at work on Long Wharf, New Haven. At the age of twenty-one he possessed but few tools and little money, but he determined to establish himself in business. He chose a location on Mad River in Wolcot, but there were no roads, and transportation facilities were so bad that he subsequently abandoned the location. He then went to Plymouth and was there em-

(To be continued.)

THE UNIVERSAL MAINSPRING,

FOR AMERICAN WATCHES.

UNIFORM
IN
COLOR.



EXACT
IN
SIZE.

See that each spring bears the name of "Universal." All others are imitations.

The Acme of Perfection in a Mainspring and the BEST QUALITY or the BEST manufacturer in Europe.

DON'T use two dozen cheap springs for six watches while we GUARANTEE that you can rely on ELEVEN "UNIVERSALS" in every DOZEN.

Save Time, Money and Reputation
By Doing GOOD WORK with GOOD MATERIAL.

Price: \$1.50 per Dozen; \$15.00 per gross.

Packed in anti-rust tin boxes ESPECIALLY MADE FOR THIS SPRING.

For Sale by all Jobbers. Imported by

HAMMEL, RIGLANDER & Co.,

35 MAIDEN LANE, NEW YORK.

If you cannot obtain the UNIVERSAL from your Jobber, notify the Importers and they will supply you with a list of Jobbers who do keep it.

HENRY TROEMNER,
No. 710 Market Street, PHILADELPHIA.

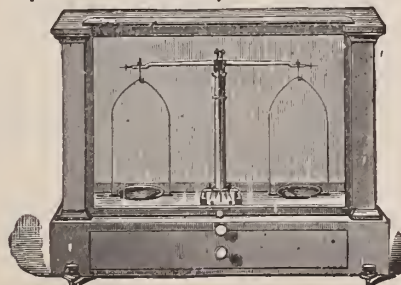

Manufacturer of FINE GOLD SCALES and DIAMOND SCALES
Bullion Balances and Weights, in use at all the U. S. Mints and Assay Offices. Priced Catalogue on application.

THE **RYDER & DEARIE**
DESIGNERS & ENGRAVERS

Fine Commercial and Copper-Plate Printers.

A Specialty of

Jewelers' Printing, Cuts and Electrotypes.

Headquarters for JEWELERS' CARDS.

BEST WORK,

PROMPT DELIVERY,

LOW PRICES.

No Order Too Large! None Too Small!

146 Westminster Street,

PROVIDENCE.

RHODE ISLAND.

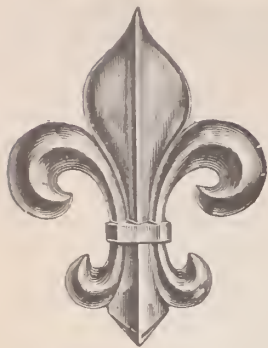

Fleur de Lis "VICTORIAS."

WE ARE SHOWING THE

Most Popular Line

IN THE MARKET.

H. F. BARROWS & Co.,

1 1/2 A Maiden Lane, N. Y.



NEW YORK OFFICE.

PRESCOTT BUILDING,
ROOM 40. SAMPLES ONLY.

WORKS, BLACKSTONE & GAY STS.
TAKE PRAIRIE AVE CAR

Providence, R.I.

WATCH DIALS.

Any kind watch dial duplicated within ten days. Factories supplied with dials for their entire product or with special designs for their high grade movements. Special rates for large quantities. Emblems, photographs, landscapes and ornamental work of every description on plain, enamel or under glaze.

WALTHAM DIAL CO.,
WALTHAM, MASS.

A. RICKERT. C.A. STIEHLE.

RICKERT & STIEHLE,
MANUFACTURERS OF

GOLD CHAINS,

SWIVELS AND SPRING RINGS.

Chain Repairing a Specialty.
13 & 15 Franklin Street, NEWARK, N. J.

WE DESIRE to call your attention to our large and varied assortment of

Complicated, High Grade Gentlemen's and Ladies'



In Gold Cases, both Plain and Enameled, in Choice Designs.

THE LARGEST STOCK EVER SHOWN IN THIS COUNTRY.

NON-MAGNETIC WATCH CO.

OF AMERICA.

CHAS. McCULLOH, RECEIVER

177 Broadway, NEW YORK.

AIKIN, LAMBERT & Co.,

23 Maiden Lane,

NEW YORK,

Manufacturers and Exporters of

Fine Gold Pens, Pencils,

TOOTHPICKS, HOLDERS,

And Novelties in Silver, Pearl, &c.



THE BEST FOUNTAIN PENS.

New Assortments in SHOW CASES and FANCY TRAYS for JEWELERS. Price Lists and Catalogues for intending Purchasers.



Also American and Swiss Watches.

DIAMONDS, Loose and Mounted,

Gold and Silver Thimbles,

CHAINS and JEWELRY in New and Staple Patterns.

ESTABLISHED 1837.

TAYLOR & BROTHER,

OLD HOUSE READ, TAYLOR & CO.

IMPORTERS OF

DIAMONDS and PRECIOUS STONES,

CLOCKS AND BRONZES,

860 Broadway, cor. 17th Street, N. Y.

Branch Office for Clocks and Bronzes,

1 1/2 MAIDEN LANE N. Y.

E. R. STOCKWELL,

19 John Street, New York.

All descriptions of

BADGES, * MEDALS, * PINS,

For Colleges, Schools and

all Societies,

IN SILVER AND GOLD.

Jobbing and Repairing for the Trade.



RUSSELL HOUSE, DETROIT, MICH.

Always a Favorite of the Jewelers, for the following (three) reasons:

1st—Excellence of its cuisine. 2d—Its central location to the trade they visit. 3d—Ample security its spacious vaults offer for samples and valuables.

CHITTENDEN & McCREARY, Prop'rs



Easy Lessons for Opticians.

BY C. A. BUCKLIN, A. M., M. D.

THERE are two methods of detecting and locating weak muscles which have sufficient strength to maintain the binocular visual act, but owing to the fatigue resulting from their overwork, occasion most annoying weak vision. The first method was recommended years ago by Von Graefe, and was known as his "Test for muscular balance." It was practiced in the following manner: To test the vertical balance of muscles, a prism of 10° was placed before one eye, base exactly in. A candle, under these circumstances, at twenty feet will appear as two candles. If vertical balance is present, the candles will appear at the same height; if it is not present, the lights will appear to be at unequal heights. The prism base, up or down, which is necessary to bring the lights to the same level represents in prism degrees the amount of the vertical defect. This method has been revived and run into the ground about once every ten years. Numerous appliances have been invented for detecting muscular weaknesses, all of

which are dependent on this principle, and a number of new terms have been presented to the literature which are entirely dependent on this form of examination. All optical stores have special frames for insuring that the prisms are placed before the eyes in exactly the required position. Maddox prism is also an outgrowth of this method of examining for weak muscles.

The test for the balance of the horizontal muscles is made as follows: a prism of 8° is placed before one eye exactly up or down. This will produce double vision; if the two candles seen at twenty feet are directly over each other the balance between the horizontal muscles is said to be normal; if they are not over each other, the prism base in or out which is necessary to bring them in a vertical line will measure in prism degrees the amount of the defect.

This entire method starts with the supposition that muscular balance between the ocular muscles is the physiological condition even when the eyes are deprived of all incentive to "fix," by being forced to see double by a prism so placed that it cannot be overcome. Weak muscles and diplopia are existing defects, and intelligent efforts to relieve the weak muscles are frequently rewarded by gratifying results, but the method we have been describing does not give reliable and uniform results.

After ten years of experimenting, I am convinced that muscular balance does not necessarily exist between the ocular muscles

of many persons having normal muscles when forced diplopia is produced by a prism. In some people this test works very well, but it will not prove reliable in the hands of unbiassed experimenters.

However, when muscular balance in all directions is found to exist by this test, it indicates healthy muscles, but the opposite does not always follow, when the muscular balance does not appear to exist. The only claim I can make for any test depending on this principle is, that it may be used as confirming symptoms or other experiments which indicate the existence of weak ocular muscles.

A second method which gives fairly reliable results is to determine how many degrees of prism each set of muscles will overcome before the individual will submit to the annoyance of double vision. Thus the vertical muscles are very weak, as their chief function is to direct both eyes at the same time; therefore the more nearly they are balanced, the more perfect is the muscular condition. The balance is so close in most individuals that a prism of 2° base up or down will produce double vision. When it is found that any one vertical muscle is sufficiently ponderant over its fellow vertical muscles, and that a prism of four or more degrees can be overcome without producing double vision, it is extremely probable that a sufficiently extensive vertical muscular defect exists to produce annoying muscular asthenopia.

**EZRA KELLEY'S
Famous Watch, Clock and Chronometer Oils,**

RECEIVED AT THE
EXHIBITION UNIVERSELLE, PARIS, 1889,

The only Award of Merit given to Manufacturers of American Oils

It is to the interest of every Watchmaker to use in his work the *Best Oil* obtainable, regardless of cost Mr. Kelley's claim to be the foremost manufacturer of Oils, giving the best results, is not based upon his own assertion, but is founded upon the fact that wherever his Oils have been exhibited in competition with other makes, subject to an examination of experts, they have received the highest *Award of Merit*.
For sale by all the Leading Jobbing Houses.

HENRY GINNEL & CO.,

GRIMSHAW & BAXTER, EUROPEAN AGENTS,
35 GOSWELL ROAD, LONDON, ENGLAND

GENERAL AGENTS,
31 Maiden Lane, NEW YORK

LOUIS NEWMAN, JR.

GOLD AND SILVER

Plater, Fire Gilder and Colorer.

Gilding by a New Process. Watch Cases, Jewelry and Novelties, Work stands acids, and in finish equal to Gold.
36 & 38 JOHN STREET, NEW YORK.

**WIGGERS & FROELICK,
60 NASSAU ST., NEW YORK,**

Sample Cases and Trays

For Watches, Jewelry, Optical Goods, Etc.

WE STRIVE TO MAKE THE BEST

**TO THE TRADE.
FINE WATCH REPAIRING**

BY
JOHN C. SIMMONDS,

18 JOHN STREET, NEW YORK.
New pieces, such as Chronometer Locking Springs, Balance Staffs, &c., made in the best styles. Watches sprung and adjusted to temperature and positions.

THE LATEST PARISIAN NOVELTY.



MANUFACTURED BY
CROSSIN & TUCKER,
100 Pine Street, Providence, R. I.

GENTLEMEN: I thank you for past favors, and further, those hair-pin chains are going all right. We are having a good demand for them. I knew they could not help going, they are so dressy. While I am constantly trying to introduce novelties, the old ones are so good it is hard to get the people to change. Well, I would just as soon sell the old ones, and if you want any Eye-Glass Holders and Chains, shall be pleased to hear from you.

Respectfully,

S. F. MERRITT,

Springfield, Mass

Essex Watch Case

COMPANY,

T. B. HAGSTOZ, President.

TRADE MARK



6 Maiden Lane, N. Y.

OFFICE.

FACTORY,
NEWARK, N. J.

GOLD FILLED CASES.

Ludwig Nissen
Edward J. ...
Mar. 6 Chase

18 JOHN ST. NEW YORK.

MOORE & HORTON,
MANUFACTURERS OF
SOLID GOLD JEWELRY,
No. 11 Maiden Lane, New York.
Fine Imitation Diamond Goods a Specialty.
Selection Packages sent on Application.

The New Trenton



18 SIZE, SEVEN JEWELS, NICKEL.
HUNTING AND OPEN FACE S. W.

Quick train, straight line lever escapement, safety centre pinion, enamel dial, beautifully damaskeened and exceedingly attractive in appearance.

THE BEST LOW PRICED WATCH EVER PRODUCED.

For Sale by the Jobbing Trade.

TRENTON WATCH CO.

TRENTON, N. J.

ALEX. WIEDERHOLD,
20 MAIDEN LANE, N. Y.,
REPAIRING JEWELER.

Jobbing sent to me by mail or express will be repaired and returned promptly. Prices Moderate and First-class Workmanship Guaranteed.

The average individual will be able to overcome eight degrees of prism base in with his external muscles at twenty feet. In some individuals the power of the external muscles may be measured by two degrees of prism, and still the person experiences only very slight asthenopic symptoms during distant vision, and no asthenopic symptoms at the working distance.

The ability of the internal muscles in the average individual is measured by his overcoming from twelve to forty degrees of prism base out. The figures vary considerably, as the individual acquires the trick of exerting his muscles in the proper way to overcome prisms. Persons who at the start cannot overcome more than ten degrees of prism with their internal recti muscles, after a few trials are able to overcome from fourteen to twenty degrees of prism.

Both methods described may be used as tests at twenty feet or at the working distance. In the near test the visual object used is a straight line with a ball on it. The line and ball may both be black or they may both be white on a black ground. Some authors think the white line and ball are better, as they are less liable to evoke undue efforts of accommodation. I do not think that the test for weak muscles at the near point is of any great value in deciding the question of the prisms required, providing the second prism test described was made. If a muscle is weak it will show its weakness quite as clearly when forced to its capacity on a distant test as it will on a near test.

Conclusions as to the existence of weak muscles, and what is best to do for them are not always satisfactory. A conclusion should be based upon all the possible factors in the case.

The complaints of the patient should be carefully analyzed, and compared with the results of the tests. These two factors should be carefully compared with the actual advantages gained by the use of the prisms as demonstrated by their experimental use. If these factors are all intelligently considered, there is but little danger of making a mistake in prescribing prisms. If the individual attempts to follow exclusively one given line of tests in ordering prisms, he will make many annoying mistakes, for prisms are at best very uncertain optical appliances.

We have now described the various methods of locating weak muscles. In our next, we will complete the treatment of weak and paretic muscles.

Chance to Sell Back Numbers.

WALTHAM, Mass., March 30, 1891.
To the Editor of The Jewelers' Circular:
We find that we that we have complete files of THE JEWELERS' CIRCULAR from 1874 down to the present time, except those of March and Dec., 1878, of 1881, July and August, and of 1885, May. In 1883 we have only Feb., March, April, Oct., Nov. and Dec. We do not particularly care about completing the set of 1873, but would like the other numbers if they can be easily obtained.

AMERICAN WATCH TOOL CO.

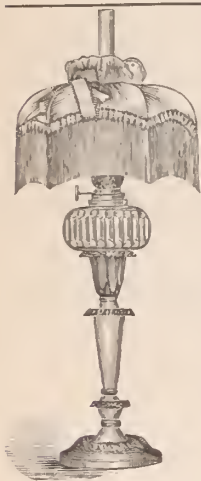

THE PRINCESS LAMP.

The handsomest decorative Lamp ever produced. Made in largest variety, and richest designs by

GEORGE EAKINS & SON,
616 Chestnut St., Phila., Pa.

Made expressly for fine Jewelry Trade.

SEND FOR DESCRIPTIVE PAMPHLET AND PRICES.

KENDRICK & DAVIS,

LEBANON, N. H.

MANUFACTURERS OF THE

Standard Dust Proof Watch Key.



After this date all Keys of this Style will have number stamped on each Key.

FOR SALE BY THE TRADE.

ESTABLISHED 1873.



If for any reason you should desire the services of an AUCTIONEER, and will write me as to the amount of stock you have on hand and its general character, the size of your store and the number of inhabitants of your town or city, I could, from my extended experience, give you an idea of the amount of business you could expect under the circumstances, and, no doubt, be able to refer you to some one for whom I have sold under conditions similar to your own.

As a general reference, you could hardly find a wholesale jeweler who is not familiar with some of the numerous successful sales I have made.

I have made many successful AUCTION SALES, and have yet to record a failure to fully satisfy the owners. Can give you hundreds of references to that effect.

If the business should be urgent and I am myself engaged, I have two competent assistants instructed in my methods whom I could send on short notice.

Any correspondence with me will be strictly confidential in every case.
P. O. Box 2775.

NEW YORK CITY.

**YOUR TOTAL SALES
AND EXPENDITURE**

By the Day, Week and Month, shown at a glance by the "Complete Business Register," the best arranged book for keeping a record of the condition of one's business. Send for free sample sheet, prices, etc. Address,

H. W. PAMPHILON,
30 Bond Street, New York.



**A Wonderful
TOOL
FOR THE BENCH.**

Instantaneous in Its Work.

Dividing the inch into one thousand parts. A most practical tool for watchmakers for gauging from a hair-spring to a main-spring. Non-comparable for a height and depth gauge. Instantaneous for hair-spring work.

For sale by all
Jobbers.

NORDMAN BROTHERS,
120 Sutter St., SAN FRANCISCO, CAL.
Sole Agents for the United States.

ESTABLISHED 1841.

CARTER, SLOAN & CO.

MANUFACTURERS OF

FINE JEWELRY,

15 MAIDEN LANE,

NEW YORK.

A. CARTER, JR.
A. K. SLOAN,
C. E. HASTINGS,
GEO. R. HOWE,
WM. T. CARTER.



Factory, NEWARK, N. J.

**WATERBURY CLOCK CO.,
CLOCK MANUFACTURERS.**

SALESROOMS:

10 Cortlandt St., New York,

GEO. M. VAN DEVENTER AGENT.

SALESROOMS:

114 & 116 Wabash Avenue,
CHICAGO,

CHARLES J. DODGSHUN, Agent.

SALESROOMS:

528 & 530 Market Street,
SAN FRANCISCO.

A. I. HALL & SON, AGENTS.

FACTORIES:

Waterbury, Conn.

123 Stockwell Street, Glasgow,

T. R. DENNISON, AGENT.

The Other Side of Life.

THE SHORTSIGHTED PROFESSOR.



"I will see again how much I weigh! Zounds—"



What a large slot this machine has!"



"One hundred and twenty pounds! You should grow more, mister!" — *Fliegende Blätter.*

FASHIONS IN PRECIOUS STONES.

Emeralds are being worn by Irishmen. Rubies are worn by those who prefer red

to white wines; also by pugilists.

Young girls love turquoises; Baltimoreans prefer turtoises.

Diamonds find favor with baseballists, besides hotel clerks.

Undertakers love the beryl.

Topaz are played out, while toppers are tired.

At this time of the year, young people generally are inclined to a gate.

Everyone named Alexander is not wearing Alexandrites.

Moonstones are worn by lunatics.

A JOCLAR SILVERSMITH.

FATHER (a silversmith)—So you have become a pitcher in a baseball nine!

SON—Yes.

FATHER—Don't you think you could urn a living more ladlelikely, I mean gentlemanly than as a pitcher in a base bowl team?

FASHION IN HEARTS.

Fledgeley—Will you be mine? I love you with all my heart.

Alice—Of what is the heart made?

Fledgeley—Of shriveled muscular tissue at present.

Alice—I don't care for it. Hearts made of diamonds are more fashionable.

DURING THE SOUVENIR SPOON CRAZE.

Mrs. BILLSDOO—Very sad about Mrs. Verisoft, this morning. She died while drinking tea.

Mrs. BULLION—How painful! What was the design of the spoon?

A CASE FOR THE OPTICIANS.

JUDGE—You say you were struck by the rays of the moon last night?

DEFENDANT—Yeshshir.

JUDGE—But there was no moon.

DEFENDANT—Yesh, waz; izh waz two of 'em; shaw 'em.

HILDRETH MANUFACTURING COMPANY,

53 MAIDEN LANE, NEW YORK.

MANUFACTURERS OF PLAIN SOLID GOLD RINGS.

SEND FOR PRICE LIST.

A. WITTNAUER,

30 Maiden Lane, New York,

MAKER OF

COMPLICATED * WATCHES.

TIMING WATCHES

OF ALL STYLES.

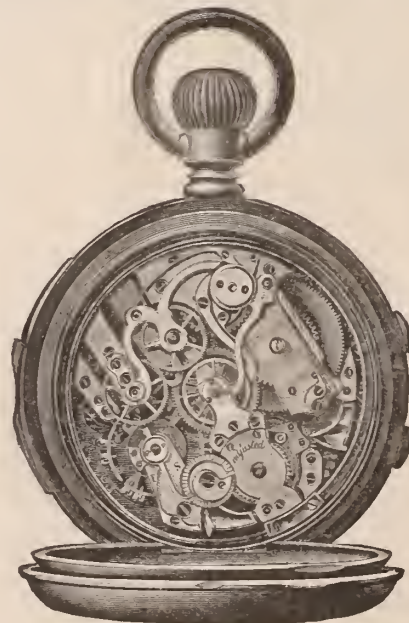

SPLIT SECONDS

AND

Minute Repeaters.

VARIOUS GRADES, ALL ACCURATELY MADE.

Also Sole Agent for the Celebrated LONGINES & AGASSIZ Watches.

HAVE YOU TAKEN YOUR INVENTORY?

HAVE YOU REMEMBER —Old gold or silver? If so, —That we pay 4 cents per kt. for gold and highest market price for old silver.

HAVE YOU —On hand a collection of old plated jewelry filings, sweeps, etc., or a lot of old jobs, which have been on hand for years, with no likelihood of being called for.

HAVE YOU —A lot of old style and unsalable jewelry on hand? If so, it would be good policy to dispose of same, convert the proceeds into an article that you would probably turn over several times, besides give your stock a nice, clean appearance.

OUR PLAN —Immediately on receipt of shipment, we will remit by cash or draft (as desired). If our offer should not prove satisfactory, we will return consignment in exactly same condition as received and pay all charges. By this arrangement you are absolutely safe, as it is no sale unless our offer should prove satisfactory, and you run no more chances than if you were disposing of same right over your counter. —Send for our little book giving pointers on testing and buying gold and silver. Mailed free on application.

GOLDSMITH BROS.

Gold and Silver Refiners and Assayers,
63 & 65 WASHINGTON ST., CHICAGO, ILL.

Columbus, Ga., Jan. 10, 1891.
Dear Sirs: Yours of the 7th inst. to hand, containing check for \$29.88. All satisfactory. Accept thanks.
Yours truly,
C. M. KINSEL.

Denison, Tex., Jan. 6, 1891.
Goldsmith Bros., Chicago, Ill.
Gents: Your draft of Jan. 3, '91, came to hand this day. Amount very satisfactory. (\$112.93).
Very Respectfully,
B. W. MERRILL.

Los Angeles, Cal., Jan. 6, 1891.
Messrs. Goldsmith Bros., Chicago, Ill.
Gentlemen: Your favor duly to hand, containing check for \$176.64, which is satisfactory to us.
Yours,
J. F. GRANAS & CO.

Little Falls, N. Y., Jan. 12, 1891.
Dear Sirs: Your favor of Jan. 9 received, which is satisfactory. Respectfully,
ANDERSON & HOUGHTON.

Keokuk, Iowa, Jan. 3, 1891.
Gentlemen: Accept thanks for check for \$153.58 in settlement for old silver.
Yours Resp'y,
T. R. J. AYRES & SONS.

Decatur, Ill., Jan. 19, 1891.
The check for \$65.45 is all satisfactory.
O. E. CURTIS & BRO.

4 Center Ave., Pittsburgh, Pa.
Gentlemen: \$54.32 received for old gold. Thanks. Am satisfied beyond expectation.
Respectfully,
H SCHEINEMAN

Milwaukee, Wis., Jan. 23, 1891.
Gents: Your favor of yesterday, inclosing check for \$205.80, to hand, which is very satisfactory.
Yours truly,
C. PREUSSER JEWELRY CO.

St. Cloud, Minn., Jan. 2, 1891.
Gents: Your check of \$12.01 is very satisfactory, more than we expected to get. Many thanks.
Respectfully,
GEO. R. CLARK & CO.

Moberly, Mo. January 2, 1891.
Goldsmith Bros.
Gents: Your express order for old gold received. Same satisfactory. I get a great deal of old gold and silver, and have sold same in New York and Philadelphia, but have never received what I thought full value until I commenced sending to you. This is my ninth shipment to you.
Respectfully,
A. F. SEELEN.

WE ARE HEADQUARTERS



For **ANYTHING** and **EVERYTHING** in the **OPTICAL LINE**, and with our large factories, equipped with the most improved machinery, and 500 skilled workmen, we are producing goods which competitors cannot reach either in **PRICE** or **QUALITY**. See our samples and learn our prices before buying your stock. 400 styles of Spectacles and Eye Glasses, from the cheapest to the best. So we are sure to suit you.

HEADQUARTERS FOR OPERA GLASSES.

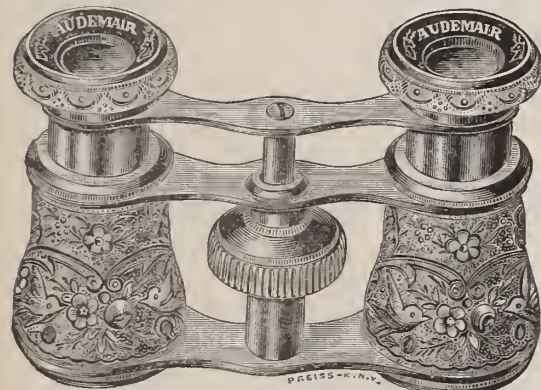

"Audemair" Opera, Field and Marine Glasses are increasing in popularity; the carefully finished achromatic lenses, good workmanship and beauty, have won for them a reputation and created a demand which exceeds our most sanguine expectations. We now carry a larger stock and more varieties than any house in the country. Customers are already sending in their orders and having their names engraved on eye-piece.

HEADQUARTERS FOR OPERA GLASS HOLDERS.

The Spencer Opera Glass Holder has proved a great success. The positiveness and simplicity of the clamping device is appreciated wherever shown. The trade are sending in their holders of other makes and having them exchanged for ours. Great variety of designs and new ones in preparation.



SEND FOR CATALOGUE AND PRICES OF ANYTHING YOU NEED IN THE OPTICAL LINE.

The **Spencer Optical Mfg. Co.**, Manufacturing Opticians,
15 MAIDEN LANE, NEW YORK.

READ VISUAL DEFECTS AND THEIR CORRECTION, BY DR. STOUT.

FALKENAU, OPPENHEIMER & CO.,



40 MAIDEN LANE, NEW YORK.

P. O. BOX 3314.

B. & W. B. SMITH,

220 West 29th Street, New York City.

Cases with Moulding,
1-16th Inch Diameter.

Cases of Plate Glass and
no Moulding at all.

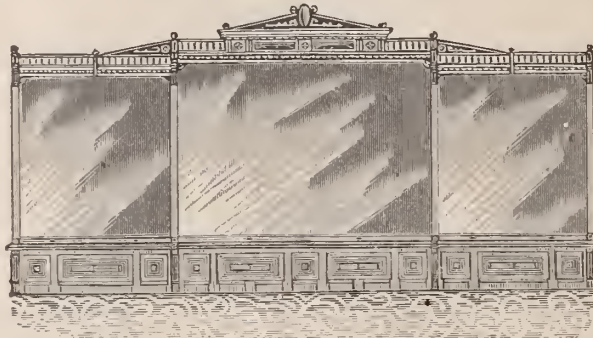

WALL CASES—PERPENDICULAR SLIDING DUST-TIGHT SASH. Shelved Complete.

Call and see our wonderful
Novelties.

They can be seen no-
where else.

Show-room open for inspection,
8 A. M. to 5 P. M.,
every day.

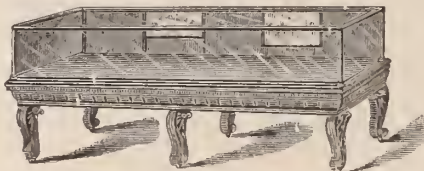

COUNTER CASE, WITH OUR PATENT DUST-TIGHT PERPENDICULAR SLIDING DOORS.

Correspondence solicited. Call and
see us, even if you do
not wish to buy.

Catalogue Illustrations Issued.



We make to Order only.

E. E. KIPLING
IMPORTER OF
PRECIOUS STONES
182 & 184 BROADWAY,
NEW YORK.

P. HOWARD,
Gold and Silver Assayer,
Refiner and Sweep Smelter,
8 & 10 JOHN STREET, NEW YORK.
Smelting and Refining Works,
28, 30 & 32 Cumberland St., Brooklyn, N. Y.
Specialties: Sweepings, Gold, Silver and Platinum.

CROWN HAMILTON
FLAT WARE
THE **ROGERS & HAMILTON CO.**
WATERBURY, CONN.

NEW! NATTY!! NOX-ALL!!!



Made in Gold, Silver, Gold Fronts and Rolled Plate. Easily
adjusted. "Send for Approval Packages."

J. A. FLOMERFELT & CO.,
MANUFACTURING JEWELERS,
177 & 179 Broadway, - New York.
Branch Offices: 78 Monroe Street Chicago.
435 Palace Hotel San Francisco.

ROY



PLATINUM SCRAPS MELTED. **ROBERTSON & LEBER,**
BOUGHT AND SOLD. Gold, Silver and Platinum Refiners,
13 & 15 FRANKLIN ST., NEWARK, N. J.

S. F. MYERS & CO., Wholesale Jewelers

EVERYTHING
THAT
PERTAINS
TO THE
JEWELRY TRADE.
22
DEPARTMENTS.



WE REQUIRE
AND OCCUPY THE
LARGEST
SALESROOMS
IN OUR LINE.
4 STORES.
GROUND FLOOR.

48 & 50 Maiden Lane and 33 & 35 Liberty Street, New York.
CONSULT OUR MAMMOTH CATALOGUES.

REMOVED.

GUNZBURGER BROTHERS, Importers of Diamonds
FROM 25 TO 35 MAIDEN LANE.

L. & M. KAHN & CO., IMPORTERS OF DIAMONDS, 10 MAIDEN LANE, N. Y.

COMPARE ALL OTHER GOLD FILLED CASES WITH THE CELEBRATED CROWN LION EXCESSOR H. MUHR'S SONS HAND ENGRAVED CASES

CIRCULATION
 FEBRUARY 40 150
 MARCH - 40,155

INDEX TO ADVERTISEMENTS,
 PAGE 28.

LARGEST CIRCULATION
 OF ALL THE
 JEWELRY JOURNALS.

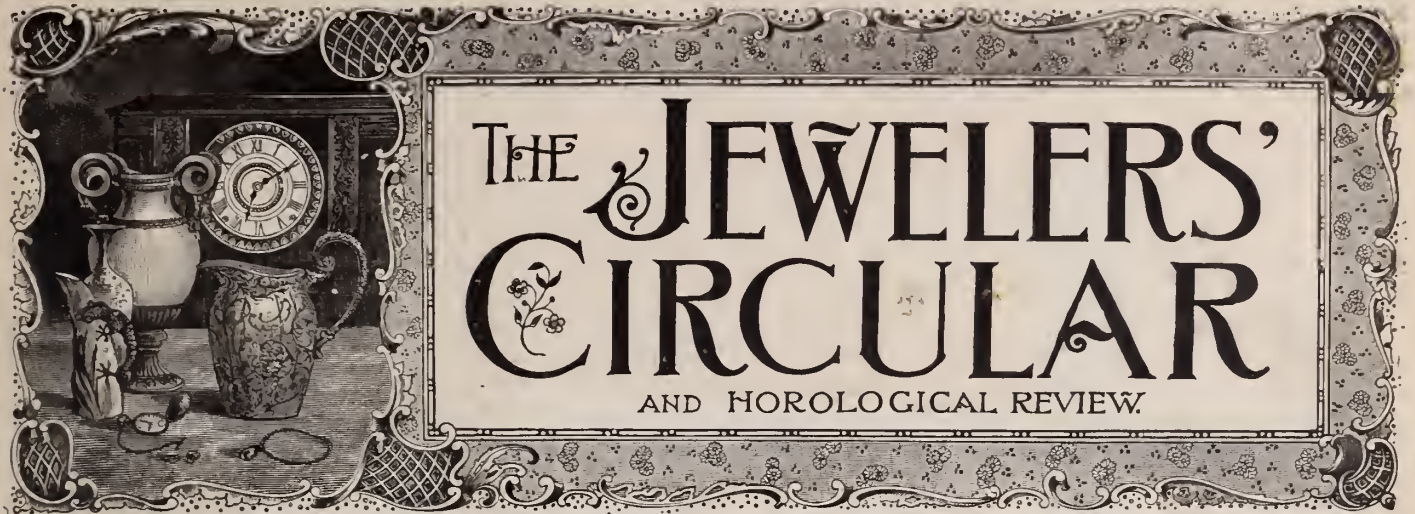

Entered at the Post Office in New York as second-class matter.

VOL. XXII.

NEW YORK, WEDNESDAY, APRIL 22, 1891.

No 12.

SOUVENIR SPOONS.

PART V.

THE writer commenced this series with the intention of endeavoring to follow out, as far as possible, a system which he had conceived. The spoons of the four or rather five classes, historical, legendary, honorary, municipal and national, were to be grouped together, and discussed individually. But as the weeks have passed, the fashion has spread so thoroughly, and manufacturers all over the country have produced so many spoons to satisfy the craze, that it is useless to attempt continuing any order of description. Hereafter the spoons will be described, as the data is gathered.

ercises an absorbing power over the faculties, its furling black flag with skull and cross bones, its pointed hats, its scowling, heavily bearded faces, its long, curved, gleam-

A representation of the Dungeon Rock, widely-known as the supposed resort of Captain Kidd and his band of pirates, embodied in a design for a souvenir spoon, does not

only lend attractiveness to the spoon, but legendary significance and interest. The wild yet pleasant place is situated in the western part of Lynn, Mass., about two miles from the city proper. It is one of the noted points of interest in the vicinity, owing to the fact that a cave once existed there, and being closed by an earthquake in 1658 formed a dungeon. The legend obtains that pirates were there entombed with all their treasures. About forty years ago one Hiram Marble, under the direction of spirit

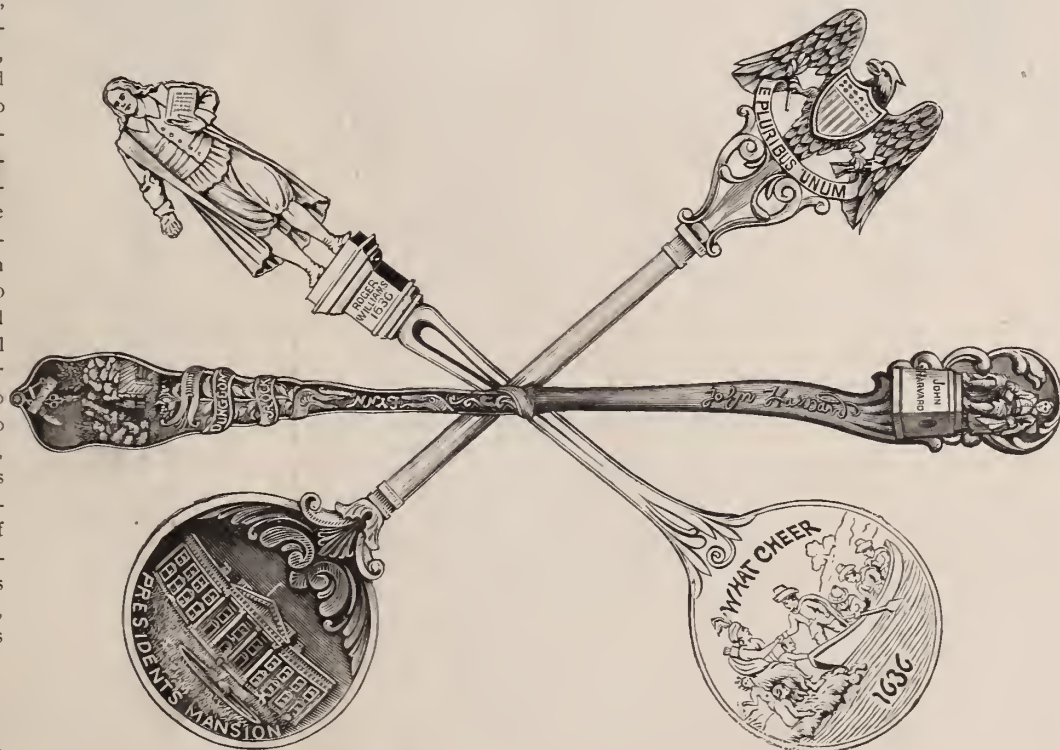

ROGER WILLIAMS, DUNGEON ROCK, PRESIDENT'S MANSION AND JOHN HARVARD.

THE
 DUNGEON ROCK.
 Dearer to the heart of every youthful male

reader than any personage that ever lived in literature is that king, that monarch, that emperor of pirates, Captain Kidd. To the youthful mind there is a "fascination frantic" about stories of piracy; its ensingia ex-

ing knives, each retaining an individual hold on the imagination. Thus the commemoration of any piratical story or tale must prove successful, for the interests of our youth are remembered and revered in our manhood.

mediums, began to search for the treasure. For more than a quarter of a century father and son toiled early and late until their death. The entrance to the excavation made by the Marbles is barred by a grating and

is guarded by a woman, sister of the younger Marble. The entire gallery is about one hundred and fifty feet long. Visitors are shown a pair of shears, a sheath and a knife, as relics of the pirates. In the spoon which



THE ALVIN WASHINGTON. THE FLORIDA.

H. M. Hill & Co., Lynn, Mass., have produced commemorating this spot shows this cave with a figure at the entrance, with the surrounding shrubbery and adjoining hut, at the head of the handle. Above the cave appear the three relics grouped. On a ribbon that twines horizontally about the handle, below the cave are stamped the words, Dungeon Rock; the word Lynn in handsome fancy letters is stamped below; flowers and leaves are a relief under the ribbon. The outline of the spoon is very original and graceful, and altogether the more the spoon is examined the more admiration it excites. The workmanship is very excellent, the many details being accurately brought out, producing a perfect ensemble. The spoon is made for coffee, tea, orange, sugar, desert and miscellaneous purposes.

THE ROGER WILLIAMS.

Perhaps nothing could be more closely allied with the history of Rhode Island, or appropriate as a gift or souvenir of the State

than a representation of its founder, Roger Williams, and his landing. It was in January, 1636, the sternest month of a New England winter, when Roger Williams left his family in Salem, Mass., where he had denounced religious intolerance, in order to escape the warrant that would have conducted him to the ship then waiting to bear him to England. He went forth an exiled man, to trust his life and fortune to the rough chances of the wilderness that then skirted the colonies of Plymouth and Massachusetts Bay. The fugitive made a settlement in Providence on lands purchased of the Indians, and so called by Williams to commemorate "God's merciful providence to him in his distress." At the top of the handle of the spoon produced to represent Rhode Island, and Providence particularly a miniature full length statue of the pioneer is seen. The details of this figure are copied from the statue in Roger Williams Park, Providence. Upon the bowl is portrayed the famous picture "What Cheer?" representing the landing of Williams upon the rock which bears his name, and is situated in Providence, on the Seedonk River. Williams is seen at the bow of the boat containing three other pilgrims, grasping the hand of an Indian. Below the view is the date 1836, and above the words "What Cheer?" The shank of the handle is of very graceful outline, and is topped by a pedestal bearing, "Roger Williams, 1636," upon which stands the miniature statue. The entire spoon is oxidized, with the exception of the back of the bowl. The general character of the workmanship of the spoon is artistic, massive and rich. The figure is excellent in detail and natural in pose, and the representation of the landing is very realistic. This spoon which is controlled by H. C. Whittier, 174 Westminster St., Providence, R. I., is made in tea, orange, coffee and souvenir sizes.

THE JOHN HARVARD.

The oldest and the most amply endowed institution of learning in the United States is Harvard College, situated at Cambridge, Mass. In 1636, the General Court at Boston agreed to give £400 towards the founding of a public school or college; but the project lay in abeyance until 1638, when by the will of the Rev. John Harvard about £700 were received and the first class was formed. The institution was named Harvard College in honor of the benefactor. Though it may be unnecessary to attempt to give any figures it may be broadly stated that Harvard graduates are represented in every town of the country, in every walk of life and every vocation. Thus an article produced commemorating the place where they spent many pleasant hours, for college life is not all digging, cramming, lectures and proctors, will receive numerous buyers. In the spoon that Freeman & Taylor, 495 Washington St., Boston, Mass., have gotten out, the head of the handle contains a representation of the statue of John Harvard, now standing in the college campus. The pedestal on which the figure sits is also seen, bearing the name, John Harvard. On the shank of the handle is a facsimile in raised letters of the old

reverend's autograph. The remainder of the spoon is plain but for the extremely graceful curves and floral designs of the outlines and borders. These latter details are so beautiful that in themselves they produce an artistic and characteristic spoon. The workmanship of the memorial details is perfect, and altogether the spoon is one of the handsomest on the market. It is made in tea, coffee and orange sizes.

THE ALVIN WASHINGTON.

This national spoon presents a bust of the Father of his Country at the top of the handle. The likeness is reproduced from the Houdin mask of Washington, taken at the time of his death, and now preserved in the National Museum at the Capital. This mask is said to give the most perfect likeness of Washington extant. The bust is in half relief, and shows the coat and cravat. Along the shank of the handle is the word Washington in raised, odd shaped letters, slanting backward. The die work of the spoon is especially fine, the details of the bust being accurately represented. The front of the handle is oxidized, enhancing the general effect, the remainder of the spoon, bowl and back, which is free of design, being bright



THE CHICAGO.

THE KANSAS.

finished. The Alvin Mfg. Co., New York, are the manufacturers of this new Washington, which is made in tea and orange sizes.

THE ALLIGATOR.

A long, slimy alligator, basking in the sun or gazing into space, is not an uncommon sight along the shores of the upper part of the St. John's River, in Florida. The word Florida, in fact, is associated in the minds of most untraveled persons, with oranges, winter hotels, consumptives and alligators, principally alligators. Thus, the embodiment of this amphibious reptile in a design for a spoon to represent the Peninsular State

ORIGINAL AND GENUINE
SEAMLESS
FILLED · GOLD · CHAINS.

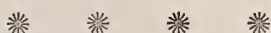

ON account of the many inquiries from our customers asking where they can see our samples in New York, we have decided to open a regular sample office at

17 MAIDEN LANE,

where a competent person will be in charge all the time, with a complete line of our popular goods.

The location is central and very convenient, and we cordially invite out-of-town dealers to make our office their headquarters when in New York.

BOSTON OFFICE,

6 WINTER STREET,
I. W. STELLE.

NEW YORK OFFICE,

17 MAIDEN LANE,
L. M. MICHELS.

San Francisco Office,

PHELAN BUILDING,
WM. E. PETTES & CO.

KENT & STANLEY COMPANY,
PROVIDENCE, RHODE ISLAND.

Address all communications to Providence office.

SOLID SILVER

EXCLUSIVELY.



WHITING MFG. CO.

Silversmiths,

UNION SQUARE and 16th STREET,

NEW YORK.

We make solid silver only, and of but one grade—that of Sterling, $\frac{925}{1,000}$ fine; therefore purchasers secure an entire freedom from false impressions, and the question "Is it silver or is it plated?" is never raised concerning a gift bearing the above trade-mark. We have produced the largest variety of special *Souvenir Spoons* for the trade, made by any silversmith.

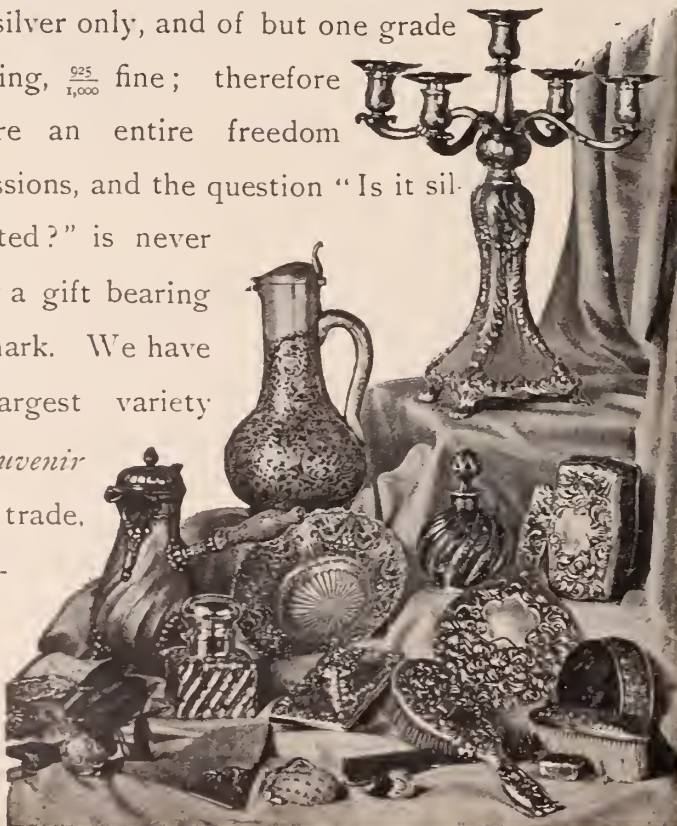

is appropriate and natural. Lengthwise along the handle of this spoon is seen a representation of an alligator in slight relief, surrounded by tropical vegetation, which continues down the shank to the bowl. Some of the spoons, which are made in tea, coffee and orange sizes, have the name, Florida, etched in the bowl. This adds character and distinct locality to the article. The front handle of the spoon is oxidized, the remainder being bright finished. The die work is excellent, the many details of the reptile being accurately reproduced. The Alvin Mfg. Co., New York, are the manufacturers.

THE HUB.

It is a mooted question, the *raison d'être* of the name Hub, given to Boston, Mass.; many believe that the name owes its origin through the general circular shape of the city; others, and they are far in the majority, agree in thinking that the name was originated and handed down to the present generation, by some generation of Bostonians, who in their simple modesty considered their city the hub of the wheel of culture, refinement and learning of America. This opinion of its origin is based upon the light in which the present generation of Bostonians hold their city in comparison with the remainder of the United States. The comic paragraphers, artists and cartoonists of the country have augmented their incomes considerably by spreading the modest opinions of themselves that those fortunate enough to live in Boston entertain, and the firesides of the spokes or tire of the wheel have often been made happy. It is a philosophical fact that the hub of a wheel does not turn so fast as the spokes or tire, as it has to turn a shorter distance in the same time. This accounts for the fact that no strong drinks of any kind are to be obtained in Boston on the Sabbath day, unless one knows where to get them. In the pretty little coffee spoon which the Alvin Mfg. Co., New York, have produced to represent Boston, the hub and spokes of a wheel, which seems to be made of wood, so fine is the work, are seen at the head of the handle. Down the remainder of the shank are in raised letters the words, From the Hub. The outline of the spoon is graceful and original. The front handle is oxidized, lending good effect, the remainder of the spoon being bright finished.

THE PRESIDENT'S MANSION.

A White House spoon has already been fully described in this series, and some facts concerning the building which the spoon commemorates have been stated. It is therefore unnecessary to repeat them in connection with the new President's Mansion spoon, which has been produced by the Gorham Mfg. Co., and which Harris & Shafer, Washington, D. C., control. The shank of the handle of this article is of attractive architectural design, terminating at the top with a representation of the national coat of arms, the eagle and ribbon bearing the motto, *E Pluribus Unum*. The lower end of the shank terminates in conventional leaves. The bowl of the spoon presents a reproduction of the White House with its surrounding

THE PAIRPOINT MFG. COMPANY, NEW BEDFORD, MASS.

Fine Gold and Silver Plated Ware.

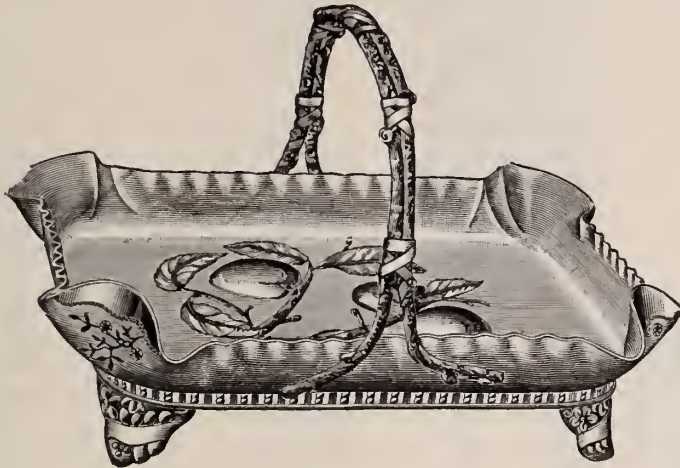

No. 1249. CAKE BASKET.



No. 2954. FLASK.

CATALOGUES AND PHOTOS TO THE TRADE ON APPLICATION.

NEW YORK.

CHICAGO.

SAN FRANCISCO.

PHILADELPHIA

SOUVENIR * SPOONS.

A FINE ASSORTMENT

OF THE

MOST ARTISTIC AND SALABLE DESIGNS.



DAVID F. CONOVER & CO.,

SEND FOR SELECTION.

PHILADELPHIA, PA

shrubbery, etc. Below the view are the words, President's Mansion. The spoon possesses the same richness, massiveness, artistic beauty and originality of design that characterize the other productions of the Gorham Company, already described. The entire spoon with the exception of the back of the bowl, which is bright finished, is oxidized.

THE KANSAS.

Perhaps, as a State, Kansas possesses no feature of interest so salient as its wheat production, and as this vegetation possesses many decorative advantages, so much so that at one time it looked as though the wheat would be chosen as the national emblem for decoration, it is natural that it has been embodied in the design of a souvenir spoon to represent that State. Seen in slight relief at the head of the handle is a sheaf of wheat tied, standing as it appears in the broad field. Held by the binding rope is a sickle. Beneath these emblemata, running down the handle, are stalks of wheat variously arranged. The workmanship of the design is excellent, the decorative advantages of the plant being fully realized. The word Kansas in fancifully shaped letters in relief is stamped on the lower part of the handle. The spoon is oxidized and bright finished, as in the case of the Washington spoon, before described. It is made for tea and orange. The spoon is applicable to any of the wheat-growing States of the broad West, and its manufacturers, Alvin Mfg. Co., will etch the name of any State in the bowl, leaving off the word Kansas in the handle.

THE CHRISTOPHER COLUMBUS.

A man may forget his algebra, his latin roots, his civil government, his irregular



THE HUB.



THE COLUMBUS.

verbs, parsing and analysis, but he always retains one fact acquired during his school days, that America was discovered by Christopher Columbus in 1492. The Crown

of Portugal was constant in its efforts through the 15th century to find a passage round the southern point of Africa, into the Indian Ocean, but before Vasco de Gama had availed himself in 1497 of the discovery of Diaz, of the Cape of Good Hope, Spain entered on her glorious career and sent Columbus across the western waters. He made four voyages in all, the first two being confined to the islands between North and South America. In his third voyage, in 1498, he discovered the mainland, at the mouth of the Orinoco River, and in his last he examined the coast of Darien. He died in Spain at the age of seventy. His body was deposited in a convent at Valladolid, Spain, but was afterward removed to Seville; twenty three years after it was taken across the Atlantic to San Domingo, and finally, two hundred and sixty years later, was carried with great ceremony to the cathedral at Havana, its present place. There is a general impression obtaining throughout the country that there will be held at Chicago, Ill., at some future date, an international exposition in commemoration of the fourth centennial of the discovery of America. The date for opening the Fair was originally fixed for October, 1892, but the majority of the people seem to feel satisfied if it is opened any time before 1895.

A spoon produced by C. M. McFarland & Co., Worcester, Mass., in commemoration of the navigator, presents a medallion of Columbus in the head of the handle. The likeness, if we are to take old prints as a criterion, is very good. Below the face, on a

The R. Wallace & Sons Mfg. Co.,



No. 230 CUP. IN STERLING SILVER, TWO-THIRDS SIZE.

MANUFACTURERS OF

Sterling Silver, Plated Ware & Fine Cutlery

FACTORIES, WALLINGFORD, CONN.

{ New York Store: 3 Park Place.
Chicago Store: 104 State Street.

ribbon furling down the handle, are the words, Discoverer of our Country. Between the folds of the ribbon is seen a ship sailing toward an island, evidently San Salvador. The date, 1492, also is given. The spoon is made in coffee, tea, orange and miscellaneous sizes.

THE CHICAGO.

In October, 1871, a fire, one of the most destructive in modern times, swept away three and a quarter square miles of Chicago's most valuable storehouses and residences. The direct loss was estimated at nearly \$200,000,000 and the loss of business at \$90,000,000 more. Notwithstanding the sudden calamity, the most extensive and disastrous that ever befell an American community, perhaps with the exception of the Johnstown flood, the new Chicago that sprung from the ashes of the old is in every respect a grander city. In designing a spoon for that city, the first idea to cross the mind would be this fire. To give a representation of houses burning

would scarcely be sufficiently significant; rather have the Phoenix, the emblem of hope and prosperity after fire, rise above the ruins. This conception has been employed by the Alvin Mfg. Co., New York, who have produced a very attractive spoon. The fabulous bird forms the head of the handle and rests upon the representation of ruins. Down the remainder of the shank is the word Chicago in slanting letters. The workmanship is very artistic, the spoon being rich and characteristic in appearance. It is oxidized and bright finished, and made in the same sizes as the other Alvin spoons described.

Discovery of a Garnet Mine.

SARATOGA SPRINGS, N. Y., April 15.—Some time since the Hon. George West purchased a tract of land near North Creek, Warren county, for the purpose of securing pulp wood. Recently a very valuable garnet mine has been discovered upon this land. Work has been begun and Mr. West receives \$10 royalty on each ton of the mineral removed.

No Bid for the Lancaster Watch Plant.

LANCASTER, Pa., April 16.—The plant of the Lancaster Watch Co. in this city, comprising all the tools, machinery and complete equipment, was offered at public sale here this afternoon by D. R. Patterson, the assignee. James Freeman & Co., of Philadelphia, were the auctioneers. Though the sale had been extensively advertised, very few people were present. Several of those present desired to purchase parts of the machinery, but owing to the fact that the mortgage of \$50,000 covered the machinery as well as the buildings, it had to be offered in its entirety. Mr. Patterson said that the cost of the plant had been variously estimated from \$200,000 to \$500,000, and that it could not be put up for the first named figure. The auctioneer made persistent efforts to get a bid, but without avail, and the sale was finally adjourned.

The store of Mrs. K. J. Smith, Altoona, Pa., has been closed by the sheriff.

THE * CHRISTOPHER * COLUMBUS * SPOON.

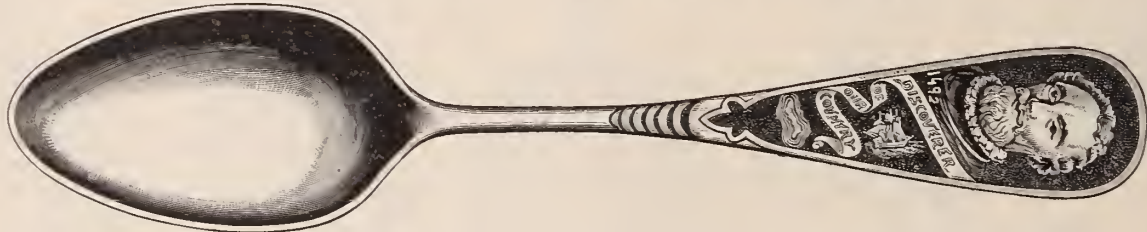

A Souvenir ante-dating anything in American History, only needs to be shown, to sell.

Made in all sizes and kinds, in sterling silver only. Prices: Teas, \$2.00. A. D. Coffees, \$1.25, Orange, \$2.25. Extra for gold bowls. A liberal discount to the trade. For circular and prices address,

CHAS. M. McFARLAND & CO.,
415 MAIN STREET, **WORCESTER, MASS.**

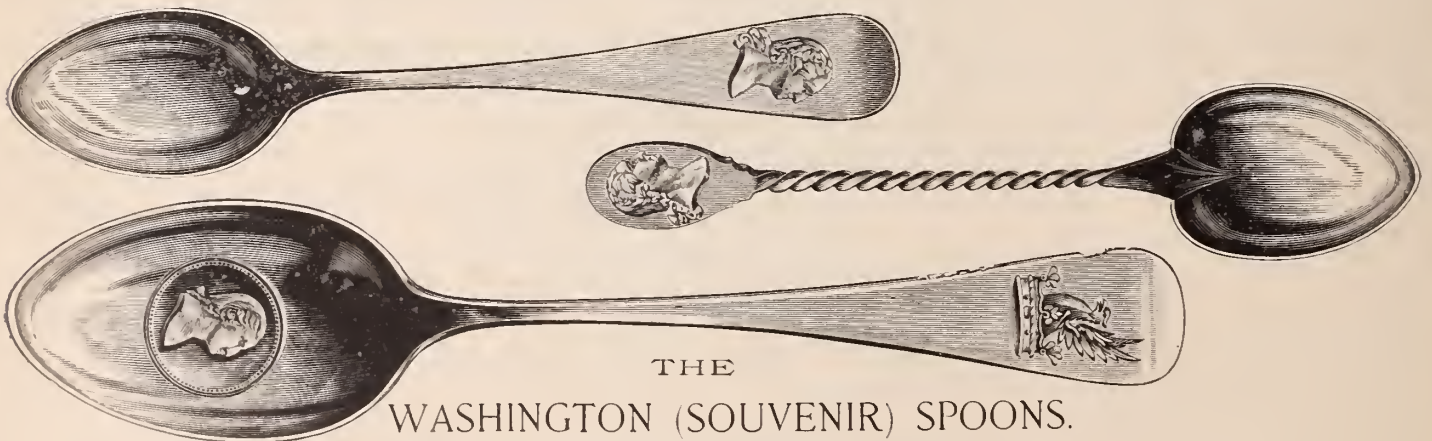

THE WASHINGTON (SOUVENIR) SPOONS.

REGISTERED TRADE MARK.

1st.—Full size Tea. Perfect likeness of the Father of his Country, in gilt bowl, with the Washington Crest on handle.

2d.—After Dinner Coffee, twist. Head on handle, plain or all gilt.

3d.—After Dinner Coffee, with head on handle.

As well as a varied assortment of other patterns.

DISCOUNT TO THE TRADE.

SEND FOR PRICE LIST.

M. W. GALT, BRO. & CO., Jewelers,

1107 Penna. Ave., WASHINGTON, D. C.

SOMETHING • NEW.

ALUMINUM THIMBLES.

Light, Durable and will not tarnish.

In appearance similar to Silver, and at half the cost.

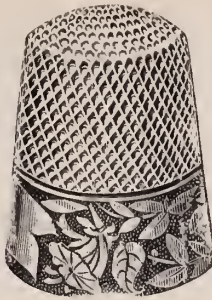

If you want something *NEW*, *HANDSOME* and *CHEAP*, send, enclosing business card, for samples and prices.

KETCHAM & McDOUGALL,

198 Broadway, New York.



MUELLER'S ARTIFICIAL EYES

ARE THE BEST IN THE

M. ZINEMAN & BRO.,

130 So. Ninth Street, Philadelphia, Pa.,

Sole American Agents. Quantities Sent For Selection'



JAMES P. SNOW.

ESTABLISHED 1834.

CHAS. E. WESTCOTT

SNOW & WESTCOTT,

SUCCESSORS TO G. & S. OWEN & CO.

MAKERS OF

FINE JEWELRY,

Lace Pins, Ear Rings, Scarf Pins, Sleeve Buttons, Sash Pins, Collar Buttons, Bracelets, Studs.

All Goods sold by us are exclusively of our own manufacture and are warranted 14 K. Fine, and stamped as such when possible.

No. 3 MAIDEN LANE, NEW YORK.

ESTABLISHED 1865.
N. J. FELIX,
MANUFACTURER OF
GOLD AND SILVER WATCH CASES,
ROOMS 6, 7 AND 8,
71 Nassau Street, N. Y. City.
REPAIRING CASES (no matter how badly damaged) A SPECIALTY.

BEECHER & CLARK,



Designs and Estimates Furnished on Application.

352 JEFFERSON STREET,

Guthrie Block, LOUISVILLE, KY.

ALVIN MFG. CO.,

* SILVERSMITHS. *

860 Broadway, New York.

206 Kearney St., San Francisco.

Factory, NEWARK, N. J.

DAY & CLARK,

MAKERS OF

FINE • JEWELRY,

BEAD NECKS AND BEAD BRACELETS

CURB AND LINK BRACELETS

STRICTLY 14 KT.

10 MAIDEN LANE N. Y.

WILLIAM B. DURGIN,

Designer and Maker of Wares in STERLING SILVER.

CONCORD, NEW HAMPSHIRE,

Cautions Manufacturers against infringement of Orange Spoon Bowl, as shown in accompanying cut, as it is fully protected by Letters-Patent.



MANUFACTURER OF FINEST LINE OF ORANGE SPOONS ON THE MARKET.

BY SPECIAL ARRANGEMENT, CERTAIN PROPRIETORS OF SOUVENIR SPOONS ARE PERMITTED TO USE THIS BOWL.

MAKER OF PAUL REVERE, NEW HAMPSHIRE AND PRISCILLA SOUVENIR SPOONS

THE BOWDEN Seamless Plain Ring,

IS MADE ONLY BY

J. B. BOWDEN & CO.,

Makers of FINGER RINGS of
every Description,

COR. BROADWAY & JOHN STREET,
NEW YORK.

TOWLE MFG. CO.,

MANUFACTURERS OF



Sterling Silverware



NEWBURYPORT, MASS.: 214 MERRIMACK ST.

CHICAGO.

149 & 151 STATE ST.

SAN FRANCISCO:

220 SUTTER ST.

BIRTHDAY * RINGS!

In order to meet the increasing demand for BIRTHDAY RINGS, we have originated and Patented an attractive novelty in the shape of an elegant tray, containing of assorted patterns, 48 Rings, four for each month, with appropriate stones and the sentiments thereof, printed upon the tray in gilt letters.

As the whole four dozen cost but a very moderate amount while we make no charge for the tray, which is of velvet and satin, as handsome as can be made, and the Rings it contains are of our latest and most desirable styles, we think that every Retailer will find it for both his interest and convenience to order this tray from us

M. B. BRYANT & CO.,

* * RING MAKERS, * *

10 MAIDEN LANE,

NEW YORK.

THE "BRYANT" INITIAL RING, easily interchangeable, still keeps the lead as the best made - SIMPLE, STRONG and HANDSOME—in trays of 6 or 12, with separate initials.

The Chicago W. & J. Co. Leave Newark.

NEWARK, N. J., April 16.—A. S. Ford, Newark manager of the Chicago Watch and Jewelry Co., a story of whose lottery-like proceedings has appeared in THE CIRCULAR at different times, has locked his office doors and fled from this city. E. B. Vliet, a carpenter, had sued the company for \$27 in the District Courts, for work done, and judgment was rendered in his favor; the concern refused to pay, and bolted.

Money for rent is also due Froelich & Koehler, and it is supposed that numerous bills are standing against the fugitives. The office was broken into late Monday afternoon and the contents, consisting only of the carpets and chairs, sold to satisfy the landlord's claim. Ninety customers of the watch lottery were transferred to an investment company doing business in Clinton St., this city.

Did They Peddle Stolen Jewelry?

TOLEDO, O., April 16.—What looks to be a suspicious case against J. Hendricks and Charles Anderson is now in the police court. It seems that information had been given Detective Duffy about 7 o'clock Thursday night that two men owning a quantity of jewelry were peddling it in different resorts in the vicinity of Market Place. The detective effected their arrest, and they were conveyed to the station. On being searched, about three dozen rings, some of them quite valuable, cuff buttons and other jewelry were found in their possession; a revolver was also found on the person of Anderson.

It is alleged that they have concealed a satchel full of other articles of jewelry, and although diligent search has been made for it in the apartments they have been occupying, no traces of it could be discovered. It is thought by the police that they have located the place where the jewelry came from. Word has been received from Elyria, this State, that a store had been burglarized there of a lot of jewelry such as that found on these men. The matter is being investigated.

One of the Washington Burglars Sentenced.

WASHINGTON, D. C., April 15.—"Yank" McLaughlin and "Rory" Simms apprehended in Philadelphia, Pa., and brought to this city, for the burglary of the store of Frank Hoffa, 409 Seventh St., last October, were up for trial on Saturday, during the February term of the Criminal Court. McLaughlin, better known as Andrew Muller, was found guilty of housebreaking. A motion for a new trial was filed, but overruled by Judge Hagner, and McLaughlin was sentenced to the Albany penitentiary for five years and six months. His counsel noted an appeal to the Court in General Term.

The prisoners had been indicted jointly, but a severance was granted and McLaughlin was tried first.



ROGERS & BRO. A-1.

OLDEST BRAND AND HIGHEST GRADE OF

ELECTRO SILVER PLATE.



For Hollow Ware.

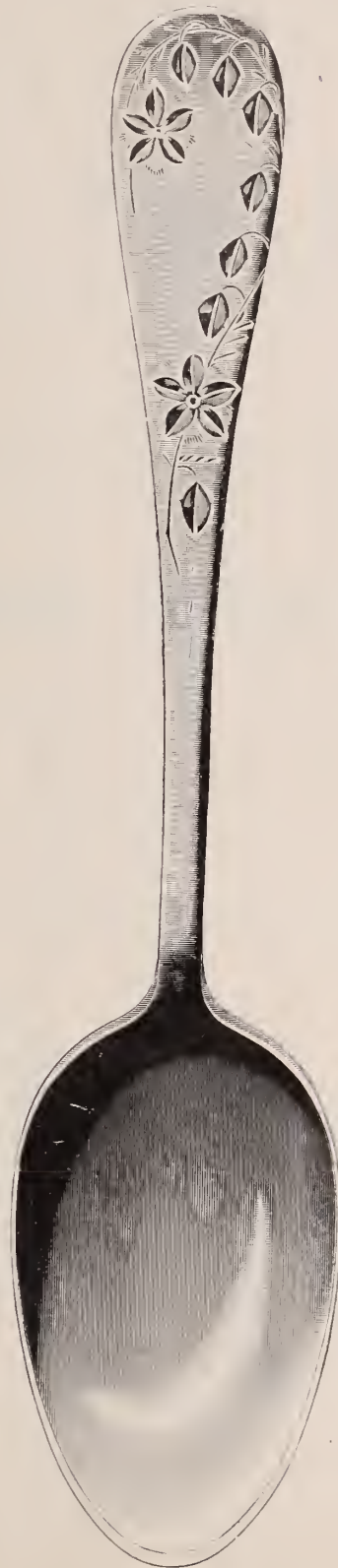
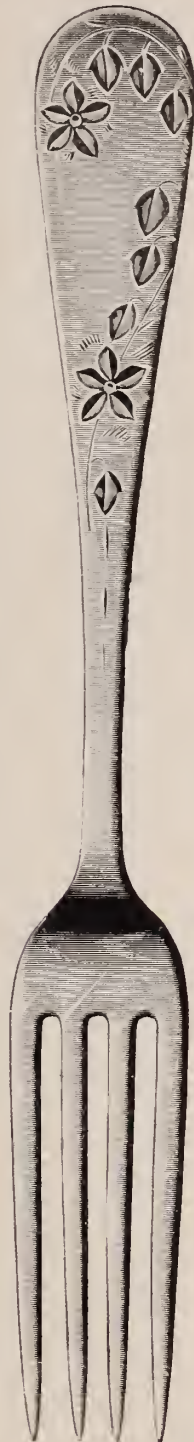

THE
"BELLE"
PATTERN.

SATIN FINISH
HAND
ENGRAVED.

MANUFACTURED BY

ROGERS & BROTHER,

WATERBURY, CONN.

No. 16 CORTLANDT ST., N. Y.

FOR SALE.

On account dissolution of partnership, *three iron safes.*
One fine large "Herring Patent Champion."

Balance of Stock. Also Fixtures, Shop Tools, &c., &c.
Must be sold before May 1st. Cheap.

Apply to

MOORE & HORTON,
11 Maiden Lane.

IT IS A FACT

that I keep the best
assortment of BOSS
and KEYSTONE
CASES in the East.

If you do not have what you can sell, send to me, and I will
send you a selection package. I also have on hand a large assort-
ment of **CHAINS AND CHARMS.**

All mail or express orders promptly filled.

E. A. WHITNEY, 403 Washington Street, Boston, Mass.

THE WENDELL ORANGE SPOON.

(OUR OWN DESIGN.)

The Prettiest and Best Selling Souvenir Orange Spoon on
the Market.

The name of your city etched in bowl.
Handles engraved all different.

Prices Very Reasonable.

Souvenir Tea and Coffee Spoons with name of your city,
or buildings, scene, statue, etc., etched in bowl to order.

All orders filled within one week.

We will etch the name of your city, with year, in bowls
of spoons of any make at \$4.50 per dozen net.

Send for new catalogue.

WENDELL MFG. COMPANY,

The only Silversmiths in the West.

63 to 69 Washington Street,

CHICAGO, ILL.



Raabe Bros.' Safe Entirely Emptied.

SAN DIEGO, Cal., April 15.—The store of Raabe Bros., 824 5th St., was burglarized about 2 o'clock last Wednesday morning, and jewelry stolen to the value of \$6,000. When Mr. Raabe reached his store the first thing to arouse his suspicions was his inability to open the front door. Securing a screw-driver he forced the door open, but at first saw nothing out of the way. The safe was locked and everything looked the same as when left the night before. Mr. Raabe unlocked the safe, but when the outer doors swung open he noticed for the first time that a small hole had been drilled with a half-inch bit through the door near the combination. Opening the inner doors he found everything had been taken; even the drawers and wood work had been torn out. In the back room he found the boxes and drawers empty, scattered about the floor. Everything of value was taken.

A closer examination being made, it was found that the burglars had entered through the skylight into the back room, lowering themselves by ropes. After effecting an entrance they opened the back doors so as to be ready to make a rapid exit if necessary. They then placed a button on the front door so as to prevent surprise from that quarter. After opening the safe they transferred everything to the back room and there made selections of such jewelry as they wished. They were evidently professionals at the work, for they selected only the best. After securing everything of value about the store, they relocked the safe and left by way of the back door, which opens onto a vacant lot on 4th St.

As soon as it was ascertained that the robbery had been committed, Chief Coyne was notified, and telegrams were sent to all parts of the country where the burglars would be likely to go.

It seems as though the thieves got in somewhat of a hurry toward the last, as a number of their tools, hammers, wrenches and jimmies were found about the building. A piece of oil cloth was found which it has been proven was bought from a local store, and a bit was also found which was purchased in this city. It is not known for what purpose the oil cloth was used. The ropes with which they lowered themselves were also found hanging from the skylight.

The loss to Raabe Brothers will amount to \$5,000. Besides the stock a considerable amount of personal jewelry was also in the safe, valued at \$1,000, which was also stolen. The burglary is attributed to the absence of lights caused by the reform methods of the Common Council of the city.

There is no clue to the identity of the thieves.

Burbeck and Gaffney, charged with burglarizing Hofman & Co.'s jewelry store Springfield, O., pleaded guilty last week. Gaffney was sentenced to one year in the penitentiary and Burbeck was sent to the reform farm.



SOME REIGNING NOVELTIES—THE BLUE STAR DIAMOND—IMITATION JEWELRY.

PARIS, France, April 11.—As Easter happened this year to fall on the very last days of March, a special turn was given to our jewelers' fancy. We see in the shops no end of April's fishes (*poissons d'Avril*). Some of ordinary size, in enameled silver, open so as to disclose pretty earrings, reproducing in vari-colored stones, the tiniest among our water inhabitants.

Pretty watch resters are coming out, the most conspicuous consisting of chased yellow gold, in pierced work applied on a deep crimson velvet piece. Some admit small turquoises or rubies symmetrically arranged in the curling ornaments.

The most fashionable pocket-mirrors are of an oval shape, adorned with sprays of flowers made of gathered stones on a frosted gold back-ground. Some exhibit chased ornaments of a Renaissance style, showing on blue enamel. Several in dull-finished gold, square, oval or round in shape, are simply decorated with a fleur-de-lis, a crest, or a fly at the top.

I noticed in a choice display an elegant silver coffee-pot in Persian style, the body of which was of a flattened oval shape, exhibiting on each face a spray of flowers *sui generis*, apparently chased on a granulated field, but really decorated by the engine turning process. The relief parts, slightly oxidized with delicate shades, are of a fine effect on the very dark ground.

A fine diamond called the Blue-Star, weighing over forty carats after cutting, has just been brought to Paris from Amsterdam. It is of a deep blue color and is perfectly limpid and absolutely without flaw. It is reported that a prominent Parisian jeweler, unwilling to let that peerless jewel go into foreign hands, is ready to purchase it at almost any price.

There is on the Boulevard des Capucines, an imitation jewelry store, which contains most remarkable specimens in the delusive line. Several hair-combs in open work are designed by real artists; brooches exhibiting floral ornaments, loosely wrapping a chimera or a fancy bird, have quite a grand appearance; diadems and necklaces of a fine style made of imitation stones, well cut, have an aristocratic air. Even after looking at the glorious displays of the Rue de la Paix, one looks upon these valueless gems with pleasure.

Some of our silversmiths are making pretty wine stoozers, as delicately decorated in repoussé as the most elegant cane tops. One of the best patterns exhibits a laughing mask of Bacchus surrounded with vine leaves and grapes.

ESTABLISHED 50 YEARS.

RANDEL, BAREMORE & BILLINGS,

IMPORTERS OF

DIAMONDS,

AND OTHER PRECIOUS STONES.

FINE PEARLS A SPECIALTY.

MANUFACTURERS OF

DIAMOND JEWELRY,

IN THE LATEST DESIGNS.

Diamonds Recut in Modern Styles or Repaired on Premises.

58 Nassau Street,
29 Maiden Lane,
NEW YORK.

1 Tulp Straat,
AMSTERDAM

1 St. Andrews St.,
Holborn Circus.
LONDON, E. C.

CHARLES H. PECKHAM,

DIAMONDS AND DIAMOND JEWELRY,

63 NASSAU STREET,

Goods Sent on Memorandum.

NEW YORK.

The Boston Bunker Hill Spoon

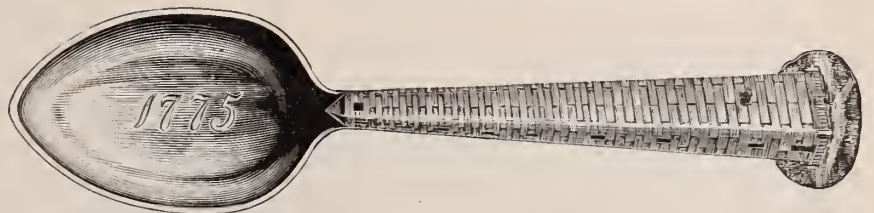

MADE ONLY, AND FOR SALE, BY

GEO. E. HOMER,

112 TREMONT ST.,

BOSTON, MASS.

FACTORY,
ST. IMIER, SUISSE.

HIPP DIDISHEIM,

83 NASSAU STREET,
NEW YORK.

IMPORTER OF WATCHES,

SPECIALTIES:

The "Nassau," the best imported movement in the market, fitting all American cases.
The "Mignon," the best Chatelaine Watch for the money.
The "Gem," a high grade Chatelaine Watch with second hand, gold crown jewels in extra settings, etc.

If your jobber don't keep these goods, send to us and we will send you the address of one who does.

OSTBY & BARTON,

SOLID GOLD BAND, STONE
-- AND FANCY RINGS --



* -- ALSO A LARGE LINE OF EMBLEM RINGS. -- *

WE DESIRE to call your attention to our large and varied assortment of

Complicated, High Grade Gentlemen's and Ladies'



In Gold Cases, both Plain and Enameled, in Choice Designs.

THE LARGEST STOCK EVER SHOWN IN THIS COUNTRY.

NON-MAGNETIC WATCH CO.

OF AMERICA.

CHAS. MCCULLOH, RECEIVER

177 Broadway. - - NEW YORK.

WATCH DIALS.

Any kind watch dial duplicated within ten days. Factories supplied with dials for their entire product or with special designs for their high grade movements. Special rates for large quantities. Emblems, photographs, landscapes and ornamental work of every description on plain, enamel or under glaze.

WALTHAM DIAL CO.,
WALTHAM, MASS.

A. RICKERT. C.A. STIEHLE.
RICKERT & STIEHLE,
MANUFACTURERS OF
GOLD CHAINS,
SWIVELS AND SPRING RINGS.

Chain Repairing a Specialty.
13 & 15 Franklin Street, NEWARK, N. J.



NEW YORK OFFICE

PRESCOTT BULDIN,
ROOM 40. SAMPLES ONLY.

WORKS, BLACKSTONE & GAY STS.
TAKE PRAIRE AVE CAR

Providence, R.I.

AIKIN, LAMBERT & Co.,

23 Maiden Lane,
NEW YORK,

Manufacturers and Exporters of

Fine Gold Pens, Pencils,

TOOTHPICKS, HOLDERS,
And Novelties in Silver, Pearl, &c.



THE BEST FOUNTAIN PENS.

New Assortments in SHOW CASES and FANCY TRAYS for JEWELERS. Price Lists and Catalogues for intending Purchasers.



Also American and Swiss Watches.

DIAMONDS, Loose and Mounted,

Gold and Silver Thimbles,
CHAINS and JEWELRY in New and Staple Patterns.

ESTABLISHED 1837.

TAYLOR & BROTHER,

OLD HOUSE READ, TAYLOR & CO.

IMPORTERS OF

DIAMONDS and PRECIOUS STONES,

CLOCKS AND BRONZES,

860 Broadway, cor. 17th Street, N. Y.

Branch Office for Clocks and Bronzes,

1 1/2 MAIDEN LANE N. Y.

E. R. STOCKWELL,

19 John Street, New York.

All descriptions of

BADGES, * MEDALS, * PINS,

For Colleges, Schools and
all Societies,

IN SILVER AND GOLD.

Jobbing and Repairing for the Trade.



RUSSELL HOUSE, DETROIT, MICH.

Always a Favorite of the Jewelers, for the following (three) reasons:

1st—Excellence of its cuisine. 2d—Its central location to the trade they visit. 3d—Ample security its spacious vaults offer for samples and valuables.

CHITTENDEN & McCREARY, Trf'rs

News Gleanings.

E. L. Hirst, Decorah, Ia., is out of business.

C. E. Bolen, New Bloomfield, Pa., has sold out.

G. H. Kimbro, Gatewood, Mo., is out of business.

J. L. Crabb, Kinsley, Kan., has gone out of business.

The Elgin National Watch Co. pay a tax of \$12,596.04.

L. V. B. Soper, Sunbury, Pa., has gone out of business.

C. Stunz, Jr., has succeeded Round Bros., Fairview, Kan.

G. W. Shipman, Fredonia, Kan., has gone out of business.

G. C. Deats, Rockaway, N. J., has sold out to C. I. Freeman.

A. Ott & Bro., Glasco, Kan., have sold out to S. C. Stahley.

Charles Weingarden has bought out G. B. Viets, West Salem, Wis.

Charles Frederick has succeeded Miller & Frederick, Palouse, Wash.

Nudd & Tyler, Amesbury, Mass., opened their new store on Monday.

V. M. Ackerman has succeeded Ackerman & Van Riper, Nyack, N. Y.

G. H. Doyle has moved from Haverhill, Mass., to Lynn, same State.

G. L. Watson, Elkton, S. Dak., is reported to have died recently.

F. Vogt has moved from Williamstown, Pa., to Mt. Carmel, same State.

Isaac Batchelder has gone out of the jewelry business at Danville, Vt.

M. Hendlman, Towanda, Pa., has made several improvements in his store.

Charles Wathen has succeeded Wathen & Burt, 1723 Arapahoe St., Denver, Col.

Maden, Koch & Maden, Salt Lake City, Utah, have closed their establishment.

Nathaniel Snyder, Center View, Pa., will shortly open a store at Lykens, same State.

J. V. Rettenbury, Dushore, Pa., has remodelled his store making it more spacious.

A. D. Morris, Minto, N. Dak., has succeeded Thomas Morris at Crookston, Minn.

F. A. Brown, formerly of Harvy & Brown, has bought out the business of H. H. Caswell, Newport, Vt.

Moritz Bernstein, 665 Lorain St., Cleveland, O., last week sold out his stock to Henrietta Miller, for \$3,465.

Last Wednesday L. R. Grieb, Butler, Pa., opened his new store with an entire new stock just purchased in New York.

Julius Weber, 11th and Spruce Sts., Reading, Pa., will soon engage in the manufacture of gold, silver and metal badges.

T. D. Gard, Worcester, Mass., last week was awarded contracts to supply class pins to the Polytechnic Institute of that city and also the prize medals to be given the winners of the N. E. Intercollegiate Athletic Association.

USE THE  **AMERICAN MAINSPRINGS**

FOR ALL KINDS OF AMERICAN WATCHES.
[FACSIMILE OF WRAPPER.]

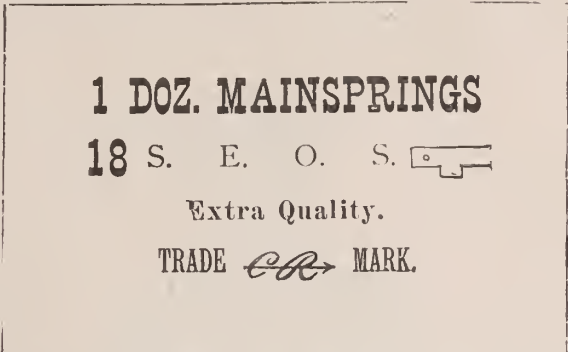

THE BEST IN THE MARKET.

L. H. KELLER & CO.,

Dealers in Fine Watch Materials and Tools.

AGENTS FOR THE PATEK, PHILIPPE & CO. WATCHES.

64 NASSAU STREET, NEW YORK.



John A. Riley & Sloan Co.

860 Broadway, New York.

MAKERS OF

HAIR PINS, HAT PINS,

TIARAS, BROOCHES,

SCARF PINS, NECKLACES, ETC.

Rosaries & Crucifixes, Chatelaines.

Our line includes both 14k. Gold and Sterling Silver.

ONE OF THE OLDEST RESTAURANTS
DOWN TOWN.



POPULAR PRICES.

NEW * DUEBER

PATENT BASSINE

SOLID GOLD WATCH CASE.

MADE IN 14 KARAT RED GOLD ONLY.



OPEN FACE AND HUNTING, 18-SIZE.

DESIGN No. 2,000,000.

The world-wide reputation of the famous DUEBER BASSINE SOLID GOLD WATCH CASE will be still further enhanced by the new and latest design as shown above.

It is a matter of record in the trade, that DUEBER WATCH CASES, by their superior finish and general excellence of workmanship, have for years been selected from the show cases of Watch Dealers, by buyers, *in preference to all others*; and in the manufacture of this DUEBER PATENT BASSINE SOLID GOLD CASE, all previous efforts in Watch Case making have been excelled, and the result is the handsomest, most artistic and perfectly constructed Watch Case ever made.

A hundred years from the time of purchase, after constant wear, its excellence will be fully as apparent as when bought.

Any one having the money to purchase one of these superb cases, will seek in vain for its equal in beauty, durability and intrinsic value.

This Case was specially designed for *Watch Case No. 2,000,000*, manufactured by THE DUEBER WATCH CASE MFG. CO. No first-class store is complete without it, as it will be selected by discriminating purchasers among hundreds of others.

This Case sold at net weight of Gold, making added. No charge for springs. Made in O. F. and Htg., 18-size—45 to 55 dwt.

THE DUEBER WATCH CASE MFG. CO., CANTON, OHIO.

A. J. GROENMAN & CO.,
DIAMOND CUTTERS,
80 NASSAU ST., N. Y.
WE MAKE A SPECIALTY OF SEL-
LING FINE, SMALL MELEES.

T. B. BYNNER,
Dealer in
Diamonds, Opals, Pearls,
AND EVERY VARIETY OF PRECIOUS STONES,
in varied and novel combinations.
177 BROADWAY, NEW YORK.

ELGIN HOROLOGICAL SCHOOL
ELGIN, ILL.

SEND FOR CIRCULAR.

Repairing for the trade.

Repair price list free.

BOOK * MARKS IN STERLING SILVER,

FRANK H. LA PIERRE,
No. 18 East 14th St., New York.

H. M. SMITH & CO.,
MANUFACTURERS OF
Gold Pens and Pencil Cases,

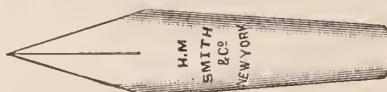

JOBBERS IN AMERICAN WATCHES.
PLATED CHAINS.

Agents for Paul E. Wirt's Fountain Pen.
83 Nassau Street, New York City.

W. J. Lasher has moved from Luberg, N. Y.

E. W. Reed, Fort Collins, Col., is advertising his store for sale.

F. H. Coombs has moved from Mahanoy Plane, Pa., to Roanoke, Va.

John Roedel has moved from Cleveland, O., to 403 Jefferson St., Buffalo, N. Y.

C. D. Williams, recently of Palmyra, N. Y., is now located at 296 Canal St., New York.

B. Lawrence has formed a company at Fort Worth, Tex., under the name of the Fort Worth Optical Co., for the sale of his eye-glasses and spectacles.

Allen Owen, Almo, Ind., committed suicide last Wednesday, by swallowing a quarter of a pound of morphine. He was a cripple and it is said he brooded over the McKinley law.

A certificate of incorporation of the Hoffmann & Maurer Mfg. Co., of Brooklyn, N. Y., was filed last week. The company are to manufacture and sell scientific instruments and appliances. Their capital stock is \$10,000.

A. E. Cutting, who was arrested at St. Albans, Vt., recently, for burglarizing French & Quimby's store at White River Junction, same State, was held last week for trial in the sum of \$1,000. All the stolen jewelry has been recovered.

The store of W. L. Reynolds, Elizabethton, Tenn., was broken into recently and property amounting to about \$400 was stolen. Thirty-one watches, a lot of finger rings and \$32 were taken. The entrance into the store was effected by boring off the lock.

W. T. Crosby was some days ago arrested in Louisville, Ky., for running a lottery in the shape of a watch club. The watches were alleged to be worth but a fraction of what he claimed. A warrant charging him with obtaining money by false pretences was recently sworn out by one of the victims.

William Kepner, Pottstown, Pa., is the owner of an eight-day clock made by the famous clock-maker and astronomer, David Rittenhouse. It is supposed to be nearly 140 years old, and since Mr. Kepner has owned it, about three years, it has not gained or lost a minute. It is a high corner clock with brass face.

When Fitzsimmons, the murderer of Detective Gilkerson, was in Canada a short time ago, he presented a number of watches to his friends. County Detective Beltzho, of Pittsburg, Pa., received a letter last week from the customs officials at Canada, stating that they had secured many of the watches. The timepieces will be sent to that city.

A thief entered the store of E. P. Vandenburg, Haverstraw, N. Y., last Tuesday, and carried off \$500 worth of silver watches. Mr. Vandenburg appeared on the scene just as the burglar was making a hasty exit, but not one of the three shots fired at the retreating robber touched him. The night watchman across the street also fired twice at the man, but he was not hurt, and made his escape.

T. P. Whiting, Woodhull, N. Y., has moved to Jasper, same State.

L. F. Follet, Appleton, Wis., has moved to Marshfield, same State.

Miller & Doty, Rochester, N. Y., have been succeeded by R. H. Miller.

John Kirschuck has opened the store formerly occupied by J. S. Chapman, Media, Pa.

F. B. McKinley, Washington, Pa., has had a self-winding electric clock placed in his store.

Herbert Hagg, Carey, O., committed suicide last week by taking poison. He had been on a prolonged spree.

The jewelry stock of the late August Koenig, Ft. Wayne, Ind., is being disposed of as rapidly as possible, by private sales, for less than cost.

John Best, Paterson, N. J., is selling out at cost, and is going to Europe to purchase silk and plush-making machinery for a new establishment in Paterson.

The store of Steward Laufer, Brodheads-ville, Pa., was entered by thieves on Friday night. A general stock of musical instruments and jewelry to the amount of over \$300 was taken.

A mysterious fire broke out in a cupboard on the second floor of F. G. Smith, Sons & Co.'s store, Detroit, Mich., last week, but was quickly extinguished, with slight damage. There is no clue to the origin.

C. E. Wilson, who uttered a bogus check on R. R. Bertschy, Memphis, Tenn., recently, and who was captured last week, at Helena, Ark., as reported in THE CIRCULAR, has been returned to Memphis, and landed in the station-house.

C. L. Ford, to whom C. L. Erickson, Omaha, Neb., assigned last January, and who has since run the establishment in his own name, closed up a week ago. Mr. Ford is negotiating with several parties for the sale of the remainder of the stock to secure the balance of the amount due him on the mortgage under which he foreclosed. Mr. Ford is the cashier of the Union National Bank.

Demise of Luciano Fabbricotti.

Luciano Fabbricotti, president of the L. A. Cuppia Mfg. Co., New York, died last Sunday at the Hotel Normandie.

Mr. Fabbricotti was born thirty-one years ago and was instrumental in forming the corporation, the head of which he was at the time of his death. When L. A. Cuppia failed some months ago, the deceased took charge of the plant and incorporated the present company with a capital of \$20,000. Offices were taken in the new Lincoln Building, Union Sq., and the concern began the manufacture of hollow ware and silver ware on an extensive scale. C. A. Cuppia, who is a brother-in-law of the deceased, is the general manager.

Last Monday both the offices and factory were closed, owing to Mr. Fabbricotti's death.

A Conflagration Affects the Trade.

One of the most destructive fires that has visited New York in recent years occurred early last Friday morning involving a loss to members of the jewelry trade of over \$175,000. The firms whose factories were burned out are Wood & Hughes, the Prentiss Time and Calendar Co., and D. F. Foley & Co. The structure destroyed was the six-story Ross building on Abingdon Sq.

The fire was discovered shortly after 12.30 o'clock, and was not under control before six hours later. It did at least \$500,000 worth of damage, and necessitated the summoning of more than thirty-five engines and twelve trucks. The Ross building, which faced on Hudson St. and ran through to Greenwich St., is now a mass of ruins, not even the walls standing. The fire was discovered by a watchman, who left the building shortly after midnight. While standing on the pavement he saw a volume of smoke break out in the restaurant under the factory of the Prentiss Time and Calendar Co. He ran to the nearest alarm box, but before the firemen arrived the entire Greenwich St. corner was ablaze. By the time the streams of water were directed on the fire the flames had spread through the second story to the front of the building. Then second and third alarms were sent out, but in less time than it takes to tell the story, the fire had swept through every floor and was pouring out of the roof, making the building a veritable furnace. At one o'clock the walls fell in with a crash that was heard a mile away.

Mr. Wood, of Wood & Hughes, was reading a newspaper about nine o'clock the same morning, when he saw in heavy type the announcement of the fire in the Ross Building. Like a philosopher, he laid down the paper and finished his breakfast. His firm lost over \$100,000. Their factory was on the sixth floor of the burnt-out structure and occupied a space of 135 x 144 feet. Everything was destroyed, including machinery, stock and dies that were the result of fifty years of business. The firm never feared fire, and their stock in course of manufacture was placed in a boiler-iron safe and protected by electricity. This is now a melted mass of silver, somewhere in the debris, and the firm expects to realize salvage on it. It was only three years ago that the firm spent considerable money in refitting their factory with improved work benches. Notwithstanding this loss, the firm want the fact impressed upon the trade that they are able to fill all orders on time, as they have a large stock on hand.

On the second floor of the building was the Prentiss Co.'s factory. Their loss is considerable but fortunately the concern have a large stock of their patent clocks in their New York office, so that orders received during the next few weeks can be filled on time. They expect to start manufacturing new tools at once. The company's first heavy shipment of clocks to England had been packed in the factory the day previous to the fire and was to have been shipped the following day. They are now nothing but masses

of twisted brass work scattered in various parts of the ruins.

D. F. Foley & Co.'s factory was also among the others. Mr. Foley loses considerable, and like the other firms is partially insured. The day after the fire a New York pen manufacturer kindly tendered him the use of his workshop until he secured other quarters.

The insurance companies demanded a very high rate for risks in the Ross Building, and Wood & Hughes intended to move when their lease expired.

Wood & Hughes were insured in forty-seven companies for a total amount of \$90,250. The Prentiss Time and Calendar Co. were insured for a total of \$28,500 in twenty-seven companies.

Window Smashing in St. Louis.

ST. LOUIS, Mo., April 15.—Particulars of a bold piece of sneak thievery, the details of which the authorities have endeavored to suppress, came to light yesterday. It appears that about 10.15 o'clock, Saturday night, J. B. Roos and a clerk were in the rear of the former's establishment, 1931 S. Broadway, when they heard a crash in the front of the establishment. Rushing to the door they were just in time to see a shadowy figure disappear around an adjacent corner.

An investigation developed that some bold thief had hurled a heavy rock through the plate glass window, shattering it into fragments. He had then grabbed up two ladies' gold watches which were on exhibition, and made away with them. One of the stolen timepieces was valued at \$125 and the other at \$400. Other articles of jewelry in the window were damaged to the amount of \$125 by the rock and flying pieces of glass. The authorities have no clue to the identity of the miscreant.

J. Steinmetz Jewelry Co. Assign.

HELENA, Mont., April 15.—To-day the J. Steinmetz Jewelry Co., 20 S. Main St., made an assignment to W. G. Bailey. The failure was caused by a disagreement among the partners. The firm about a year ago succeeded W. G. Bailey. The liabilities are placed at \$18,000, more than equalled by the assets.

Burglary in Providence.

PROVIDENCE, R. I., April 15.—To-day, for the first time in nearly ten years the citizens of this city became aware that the plant of a manufacturing jeweler had been burglarized, and as the *modus operandi* of the thief became known, it caused grave apprehensions on the part of other manufacturers, for fear that they might be victimized in a similar manner.

Friday forenoon last, A. S. Southwick & Co., 21 Eddy St., were startled to find a case of ladies' stone rings, valued at \$500, had been stolen from the safe. The firm occupy quarters on the third floor of the building, and close beside the door of the office is a small window. The door is always locked, with the key on the inside. Investigation

showed that the thief, standing in the entry, had reached through the window and turned the key, and thus, having unlocked the door, had gone to the safe and abstracted the case of rings. The theft must have taken place between 8 and 9 o'clock. It was a bold affair, as the firm's workshop was occupied at the time.

PROVIDENCE, R. I., April 17.—Detective Parker late last night arrested a notorious thief named Joseph Burke at his boarding house 143 South Main St., as being the guilty party. A search of his room brought to light the sample case valued at \$25, with eight trays of rings. About three-quarters of the property were thus recovered. Burke refused to tell where he disposed of the remainder of the rings. He claims that some one else stole them and turned them over to him.

Business Changes in Providence.

PROVIDENCE, R. I., April 20.—As is usual, several changes have occurred in manufacturing jewelry partnerships, this spring, although they are transpiring at a later date than in former years. The past week has been an exceptional one, there being five dissolutions in this city as follows:

The copartnership heretofore existing between W. H. Durfee, J. M. Dean and E. M. Sawin, under the name of Walter H. Durfee, manufacturers of English hall and cathedral clocks, at 12 Pond St., was dissolved April 15, by mutual consent, J. M. Dean and E. M. Sawin withdrawing. Mr. Durfee will continue the business at the same location.

W. H. and J. C. Blundell have retired from the firm of A. S. Southwick & Co., 21 Eddy St. Their interest has been taken by W. K. Logee, and the business will be continued under the old name.

W. R. Lane & Co., 35 Potter St., have dissolved, and the plant is advertised by H. G. Possner, the money partner, as being for sale. Mr. Possner states that the firm is out of business, but Mr. Lane denies and says he shall continue. In the mean time Mr. Possner is settling the affairs of the firm.

F. A. Stevens & Co. have gone out of existence, having dissolved April 14th by the withdrawal of F. A. Stevens. The business will be continued by E. L. Spencer & Co., who will settle up the business of the dissolved firm. The new concern consists of E. L. Spencer, for several years bookkeeper for G. H. Holmes & Co., and Horace Remington, the well-known refiner, who also constituted the company in the old firm.

The copartnership heretofore existing between C. Y. Clase, T. R. Vennebeck and C. F. Vennebeck, under the name of Vennebeck & Clase, has been dissolved by the death of Mr. Clase. The surviving partners, having purchased the interest of the deceased, will continue the business, under the same name and at the old place, 107 Friendship St.

By the recent renumbering of Point St., the following jewelers' addresses are changed:

Tuttle & Stark, 42 to 113; Etlinger & Safford, 42 to 113; C. E. McKenna & Co., 35 to 104; the building occupied by F. T. Pearce & Co., Arnold, Steere, Flint, Blood & Co., E. H. Dunham & Co., L. Towne & Co., and Dickerson Bros., 29 to 94.

Watch Clubs are Lotteries in St. Paul.

ST. PAUL, Minn., April 15.—The formation of clubs consisting of a certain number of persons who pay in a specified assessment once a week and then decide by chance who shall have the entire amount, to be expended in the purchase of some article, has become quite popular, and the plan has been variously applied to the sale of articles of jewelry, clothing and furniture. The claim that the scheme was simply a lottery, and therefore contrary to law, was put to a test in the municipal court on Thursday. John Moren a tailor, was under arrest for this alleged violation of the lottery law.

The State took the ground that the weekly drawings by chance constituted a lottery, and the jury agreed to this, as a verdict of guilty was returned after three hours' deliberation. A stay of twenty days was granted and the defence will appeal to the supreme court.

Robbed While His Back Was Turned.

FORT WAYNE, Ind., April 15.—Yesterday jewelry to the value of \$1,000 was stolen from the store of Horace Mariotte, 20 E. Columbia St. The theft was committed during the noon hour. It was a bold robbery, accomplished by professional hands. At the time mentioned two well-dressed young men entered Mr. Mariotte's store and asked to inspect some diamonds. The proprietor displayed several trays of set and unset gems. While his back was turned to procure some other goods, the two men gathered up some of the finest specimens and fled.

The officers have been working on the case quietly, but there is not much of a clue to lead to the apprehension of the thieves. Postal cards have been addressed to various places, and a big reward is offered for the capture of the thieves or the return of the jewelry.

Not a Member of the Security Alliance.

NORWALK, Conn., April 18.—Burglars made a raid on Le Grand Jackson's store, 58 Wall St., last night, and, breaking open the safe, robbed it of goods, said to be amounting in value to \$15,000, and escaped. The plans of the burglars were well prepared and cleverly carried out. Yesterday they were seen about town a greater part of the afternoon, and just about dusk entered Mr. Jackson's store and asked to see some diamonds. A tray of valuable jewels was shown them, but they made no purchases. Last night they fired a small barn on the outskirts of the town, and while the police, Fire Department, and others were drawn from the principal streets to the scene of the

fire, they hastened to the rear of Mr. Jackson's store, cut open a small door, and entered. The safe, which was standing behind a thin board partition in a back room, was soon cut open with cold chisels, and its valuable contents removed.

A Mrs. Richardson, a milliner in the Boston Dry Goods Store, who boards at the Norwalk Hotel, saw the whole proceedings from her chamber window, but was so paralyzed with fright that she was unable to utter a syllable until daylight, and then gave the alarm.

This is said to be the third heavy loss that Mr. Jackson has suffered during his ten years of business life in this city. He is almost prostrated by his heavy loss. He carried no insurance and is the only jeweler in town who has not a burglar-proof safe, and who does not belong to the Jewelers' Security Alliance. Detectives have already been put on the case, but there are only slight hopes that any of the stolen valuables will be recovered.

Death of George O. Herrmann.

NEWPORT, R. I., April 17.—George O. Herrmann, one of the oldest and best-known watchmakers and jewelers in this city, died recently of pneumonia, with which he had been ill for less than a week. He was about fifty years of age and was considered one of the best workmen in Newport.

Deceased started in business at 219 Thames St. in 1878, and remained there up to the time of his death. Previous to going in business for himself he was for many years in the employ of H. A. Heath & Co., 165 Thames St., working his way up from an apprentice to being at the time of leaving them their head and confidential clerk. Mr. Herrmann was President of the Leiderkrantz Society and prominent among the German citizens.

Can't Work Cincinnati Jobbers.

CINCINNATI, O., April 18.—W. J. Smith, representing himself to be the manager of the Globe Watch Co., of Philadelphia, Pa., has created quite a flurry in jewelry circles by his quiet approach to the jobbers for association goods under regular rates. He knows all about how they can safely sell him the goods at ten per cent. off, but the Cincinnati jobbers failed to be bitten. When Mr. Smith called on them he met with a chilly reception.

Mr. Smith was found by a CIRCULAR representative at room 83, Johnson Building, where he has desk room. A small tin sign on the outside reads, The Globe Watch Co. By the side of his desk is a traveling case, such as travelers generally use. He is about twenty-four years of age, but talks like a veteran. He disclaims any connection with the Association, and holds that his business is bona fide. On his desk were a few printed cards, some letter-head paper and a small pile of Association watch movements and cases, which he smilingly assured the correspondent that he just bought of a

Cincinnati jobber and he could get all he wanted, and that the jobbers who were so afraid of him would yet be glad to sell to him. He said he experienced the same drawback at Philadelphia, but he overcame their fear and can get goods anywhere. When asked why he particularly wanted Association goods, when club members would not care what kind of a watch they got so that it was a good one, he replied that there was a demand for the combination goods; some would have no other. He says he has organized clubs at Pittsburg, Chicago, St. Louis, and other large cities, and he proposes to establish one here. He expects to have an agent by next week, when he will leave for new fields.

The Sale of Sumner Bros. Consummated.

CLEVELAND, O., April 18.—On Monday morning the motion to set aside the confirmation of the sale and the sale itself of Sumner Bros.' stock to J. F. Sipe, of Sipe & Sigler, was overruled.

On Wednesday afternoon Charles Gale was examined in the Probate Court. He admitted that he held \$5,700 worth of diamonds, securing a \$4,500 loan, and that he had been directed in the event of Sumner Bros. failing to make payment to sell the goods.

Otto Young Retires from The World's Fair Directory.

CHICAGO, Ill., April 16.—The two most important topics of interest have been the big million dollar fire, whereby a West Madison St. retailer had his store and \$30,000 stock reduced to ashes, and the resignation of Otto Young, on Tuesday last, from the directory of the World's Fair, where he had held the chairmanship of the Ways and Means Committee, and his starting for Europe, Wednesday evening. Mr. Young although only 46 years old, virtually a young man, has been a very hard working one. Whatever he takes hold of, whether it be the personal management of a big jobbing jewelry business, the handling of, next to Wanamaker's, of Philadelphia, the largest retail notion and dry goods business in the country, or the financial reins of the World's Fair, he does so with that characteristic "Chicago-get-there", that has been applied to all of his business undertakings, and has been the rapid means, even at this early in life, of his climbing the ladder to affluence, till he is now estimated at being five times a

millionaire. In living this rapid business life, he has taxed his robust constitution beyond its endurance, and now nature demands relaxation. The many sensational stories that have gained currency in relation to his low state of health, are unfounded. The hard work and many preplexing financial problems that have bothered him over the World's Fair, coupled with his immense personal interests, have brought on insomnia, and he goes to Europe for rest. After stopping in England a few days, Coblenz, Germany, will be the next objective point. The rest of the trip is undecided upon, but he expects to be back in about two months. Julius Schnering, of Otto Young & Co., will have charge of all Mr. Young's personal affairs during his absence.

Executions Entered Against Hollinshed Bros.

PHILADELPHIA, Pa., April 19.—In Common Pleas, No. 1, yesterday, Isaac Toone, of Camden, N. J., entered a judgment note against Charles Hollinshed, trading as Hollinshed Bros., manufacturing jewelers, 806 Chestnut St., for \$3,105, dated April 17, 1891, payable in one day. Elizabeth Hollinshed also entered a note against the same party for \$2,800, dated April 17, payable in one day; Hannah A. Hollinshed, one against the same for \$3,000 dated April 17, payable in one day, and another for \$7,000, dated April 17, at one day.

A representative of THE CIRCULAR called at Charles Hollinshed's residence, 416 N. 4th St., Camden, last night, but that gentleman could not be seen, his physician having ordered him to be kept in quiet.

L. E. Brown, public accountant, will audit the firm's books.

Secretary H. M. Condit, of the New York Jewelers' Board of Trade, left New York for Philadelphia, on Monday, to investigate this matter. He represents \$3,000 worth of claims.

Another Cleveland Jeweler Embarrassed.

CLEVELAND, O., April 20.—On Saturday the sheriff took possession of the store of Charles Davis, 560 Pearl St., on claims of the First National Bank for \$2,700. To-day Mr. Davis gave a chattel mortgage, and is in charge of the store, acting as the bank's agent.

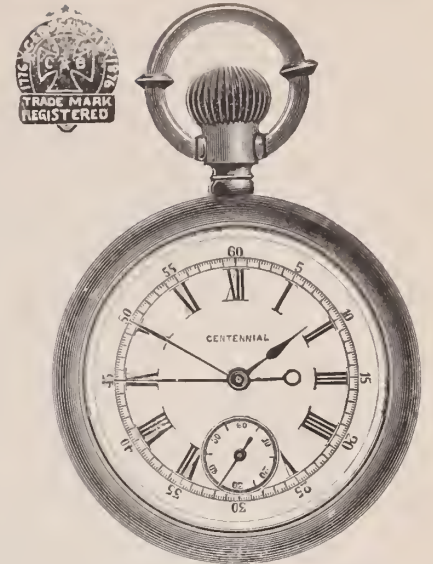

"THE CENTENNIAL"

LEADS THEM ALL.

Acknowledged by all dealers to be the best Chronograph in the Market. Made also as a Plain Timer.

Ask your jobber for them, or order of the Manufacturers,

CROSS & BEGUELIN,

21 Maiden Lane, N. Y.,

IMPORTERS OF

DIAMONDS, WATCH MATERIAL, OPERA GLASSES, Etc., Etc.

Jobbers of all grades of American Watches, Gold and Rolled Plate Jewelry.

SEND FOR PRICE LIST.

NEW GOODS—STERLING SILVER.

Spring Novelties.

Lewis Brothers,

41 Maiden Lane,

New York.

✻
✻
✻
✻

NICHOLSON FILE COMPANY,

OFFICES AT WORKS AT

PROVIDENCE, R. I. PROVIDENCE AND PAWTUCKET, R. I.

NICHOLSON FILE CO

✻
✻
✻
✻

FILES AND RASPS

For Jewelers, Watch Makers, Tool Makers and Everybody Else.

Canada and the Provinces.

C. Babbitt has opened a store at Oak Lake, Man.

W. J. Barr, of the Goldsmiths' Company, Toronto, Ont., was in Montreal, P. Q., last week.

H. W. Patterson, of Smith & Patterson, Boston, Mass., was in Montreal, P. Q., for a few days last week.

Isaac Mitchell, wholesaler, Kingston, Ont., left for New York by way of Watertown on the 7th inst.

Jacob Levy, of Levy Bros., Hamilton, Ont., spent a good part of last week in Montreal, P. Q., on business.

J. R. Ormond's store, Winnipeg, Man., was burglarized last Friday night by professionals, and a number of watches taken.

John Wenger, Victoria, B. C., is at present in Switzerland recuperating his health. He has greatly improved since his departure.

A. R. Harmon, Montreal, P. Q., the Canadian agent for Robbins & Appleton, New York, has gone to Toronto, Ont., on a business trip.

G. H. Taylor, Charlottetown, P. E. I., has moved into one end of R. K. Brace's store, where he will carry on his jewelry business for the time being.

R. Helmsley's new store, at Montreal, P. Q., will be a showy and substantial place. Eight large sized mirrors will brighten the show-windows. He moves on May 1.

The new building of the Montreal Rolled Plate Co. will shortly be occupied by half a dozen manufacturing jewelers of that city. The building is of brick and five stories high.

K. Bezonson, Moncton, N. B., has leased the rear of the store adjoining his present premises, and has had the room elaborately fitted up, being in keeping with his sales-room.

W. A. Walker, 1711 Notre Dame St., Montreal, P. Q., who is moving to a magnificent store on St. James St., is arranging to spend \$5,000 in fitting up the new establishment.

A. Cameron, Mitchell, Ont., was in the eastern markets last week making selections for his establishment. He intends to remodel his shop in a few weeks and restock it completely.

La Compagnie de Montres Courvoisier are applying for incorporation with a capital stock of \$40,000, headquarters at Montreal, P. Q., to manufacture gold and silver watches and jewelry.

THE WALTHAM SCHOOL OF HOROLOGY,

D. D. PALMER, Teacher and Proprietor.

Best Advantages in the Country for Horological Instruction.

All branches under the personal supervision of D. D. PALMER, for a number of years in charge of the Adjusting Department of the Waltham Watch Co. POSITIONS GUARANTEED TO APT PUPILS. For terms and other particulars, address

D. D. PALMER,
WALTHAM, MASS.
Specialty of Difficult Repair Jobs.

Tenders are being called for the entire stock of the late Robert Wallace, Halifax, N. S. Sarah E. Wallace and Thomas Brown are the administrators of the estate. Tenders must be in on or before May 6th.

Last week fire destroyed the building occupied by W. R. Gould, Chatham, Ont. Mr. Gould's loss is considerable, and he had been insured to within a few days of the fire, but had allowed the policy to lapse, pending a contemplated change.

The new workshop of Henry Birks & Co., Montreal, P. Q., is now in working order. It will accommodate some twenty-five workmen, but sixteen will be the usual number employed, exclusive of watchmakers. The rooms are light and airy.

The other night a second attempt was made to burglarize the store of Samuel Morin, Stittsville, Ont. An attempt was made to blow up the safe but proved ineffectual. Over \$150 was in the safe at the time, together with a large collection of valuable watches and jewelry.

The store of A. J. Fitzgerald, Norwood, Ont., was broken into the other night by burglars, and goods, consisting of watches, jewelry and knives, to the value of \$135, were carried off. Entrance was effected by removing a small pane of glass in a window at the rear of the store.

A man named Carey, who conducted a small jewelry business at St. Thomas, Ont., was, a few years ago, detected counterfeiting and was sentenced to eight year's imprisonment. Petitions asking for his release are now being circulated around Aylmer, his old home, and will be presented to the Minister of Justice.

Thieves last week broke into the establishment of Philip Brown, 590 Main St., Winnipeg, Man., and robbed the safe of over \$1,000 worth of jewelry. Investigation showed that a back window had been left open, and also that the safe had not been closed. The matter is now in the hands of the police and

ARTIFICIAL EYES!



STOCK ORDERS of
Selection Packages.

Largest Assortment.

GENEVA OPTICAL CO.,
23 Washington St., Chicago.



Mr. Brown is offering \$100 reward for the recovery of the stolen jewelry.

A special general meeting of the Toronto Board of Trade was held last week to discuss the question of closer fiscal relations between Great Britain and her colonies. There was a large attendance, and among the jewelry manufacturers were P. W. Ellis, W. Stark, R. B. Ellis and M. C. Ellis, of Toronto. M. C. Ellis declared, amidst applause, that the benefits to be derived from trading with Great Britain were much greater than could be obtained by dealing with the United States.

The "CLEOPATRA"

PATENT APPLIED FOR.

A NOVELTY IN SOUVENIR SPOONS,

In keeping with the latest fad.

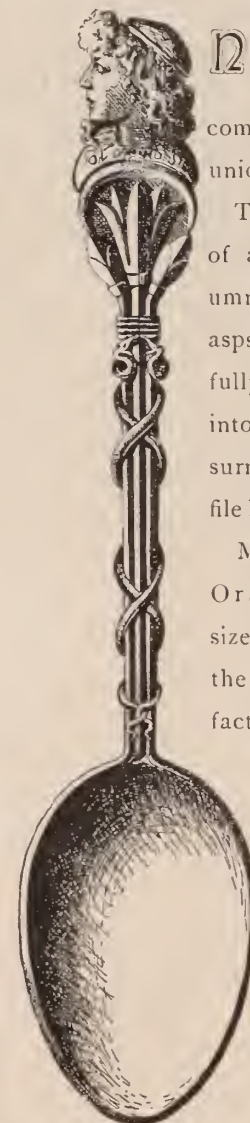

NO stock of Souvenir Spoons complete without this unique design.

The handle consists of an Egyptian column encircled by two asp's, the top gracefully branching out into the lotus flower, surmounted by a profile head of Cleopatra.

Made in Tea, Orange and Sugar sizes. In addition to the above, we manufacture a large variety of Souvenir Spoons, applicable to various localities, photos and prices of which will be furnished on application.

ALVIN MFG. CO.

860 Broadway,

NEW YORK.

Factory, 24 Boudinot St., Newark, N. J.

Providence.

H. S. Tanner has discharged a mortgage of \$800.

J. W. Cameron has discharged a mortgage for \$1,800, and given a new one for the same amount.

J. F. Allen, of Allen Jonassohn, sailed for Europe on Saturday last. He will return about June 1st.

Miss Fannie L. Holden, daughter of E. W. Holden, was united in marriage to W. R. Berry, last Wednesday evening.

Kent & Stanley have sold to the Kent & Stanley Co. one half of the valuable estate on Fountain, Eddy and Worcester Sts.

M. M. Johnson, who has been confined to his house for several months on account of

loss of sight, is now so much improved that he is able to be out.

The following jewelers are interested in the recently organized Edgewood Casino: D. F. Adams, R. E. Budlong, J. A. McCloy, H. A. Capron and S. K. Merrill.

The total value of foreign importations into this city, the past week, was \$32,000, among which was one package of imitation stones from Havre, one package precious and one package imitation stones from Bremen.

A special meeting of Lodge No. 3, Pearl Button Makers' Association of America, was held in this city Monday evening, at the residence of James O'Hearn, and considerable business of a private nature transacted.

G. B. Champlin, of S. B. Champlin & Son,

has just returned from a vacation spent in the vicinity of East Greenwich, where he was the guest of G. E. Blanchard, the well-known retail jeweler of that place. Two mornings' sport, shooting on Quonochontaug pond, produced a record seldom surpassed in this vicinity.

Among the signers of the recently organized Providence Athletic Association are the following well-known jewelers: B. E. Daggett, H. S. Dorchester, J. M. Buffinton, W. M. Otis, D. F. Adams, W. H. Thurber, H. W. Harvey, G. H. Holmes, J. A. Cross, R. H. Whittier, R. S. Hamilton, Jr., Albert Eddy and W. G. Hopkins.

Some months ago D. Spinoza, Boston, Mass., obtained a quantity of diamonds from J. A. Foster & Co., 52 Dorrance St., but

BIPPART & CO.,

Newark, N. J.



INTERIOR VIEWS OF
FACTORY.

Manufacturers of

FINE JEWELRY.

failed to make a satisfactory settlement. Learning last week that Mr. Spinoza was in town, Mr. Foster swore out a writ which was served by Deputy Sheriff McHenry. Mr. Spinoza telegraphed to his brother in Boston, who came forward and paid the bill.

F. B. Reynolds, of the Reynolds Jewelry Company, is enjoying a two weeks' visit to Canada.

Alfred Barton and his son, Nathan Barton, of Ostby & Barton, were in Warren last Thursday on business.

J. J. Bogle, of Bogle Bros., White River Junction, Vt., made his annual stock-purchasing trip to this city the past week.

A. A. Greene, of Smith & Greene, was in Cleveland, O., last week on matters pertaining to the settlement of the suit of Sipe & Sigler, of that city.

Hiram Howard introduced a bill in the House of Representatives last week to incorporate the McKinney-Smith Jewelry Co., which was referred to the committee on corporations.

C. R. Smith, of the C. R. Smith Plating Co., will be a passenger on *La Bourgogne* for Europe on April 25. He will be accompanied by several of the stockholders, who go to the Continent on business connected with the corporation.

Through the publication of a misstatement concerning the affairs of John Klipper, New Orleans, La., that jobber has had considerable trouble with the houses from whom he buys. THE CIRCULAR would like to impress upon the trade that the item published was the simplest error on the part of the correspondent who mixed the names of John Tabor, of Dallas, Tex., and John Klipper. Far from being at all embarrassed, Mr. Klipper enjoys a good credit standing with all the commercial agencies, and is capable of paying more than dollar for dollar.

San Francisco.

C. W. Richardson, recently of Woodland, this State, has located at 1330 Market St., this city.

G. A. Penniman, of Penniman & Co., has been in San Jose endeavoring to raise the necessary capital to resuscitate the Otay watch plant.

The new firm known as J. B. Trickey & Co., successors to Louis Braverman, the members of which are well and favorably known on this coast, have opened at the old stand, 119 Montgomery St., with a new and elegant stock.

A. S. Spence of the Chicago Clock Co., 1710 Market St., was arrested recently and pleaded guilty in Judge Rix's court to the charge of conducting a lottery in the shape of a watch club and paid a fine of forty dollars. He agreed to abandon the lottery feature of his watch scheme, and now over two hundred unlucky members of his club are interested in knowing how they are going to come out.

The suit of A. W. Stott against G. M. Pe-

rine to recover \$1,000, is on trial before Judge Wallace. Plaintiff avers that on Aug. 27, 1889, he sold defendant a pair of diamond earrings for \$3,000. Defendant paid \$500 cash and \$1,500 in instalment, leaving \$1,000 due. In his answer Perine avers that he was deceived in the value of the jewels, and that they are not worth more than \$1,400.

N. J. Hyman, a well-known jeweler, states that the silver chased walking sticks are now coming out to take the place of the oxidized head. The only difference is that there is more work on the former. The very newest thing in sticks is a bunch of grapes, satin finished or in chased silver. The gold-headed stick is now very highly chased. Another craze in sticks is the twisted grapevine. The silver patch stick, in olive, acacia and orange, is also popular. The orange sticks have odd animals carved on them, and are highly polished and carved. A great many tourists buy California sticks.

Newark.

A. F. Frech, now with Hoffman & Robinson, will start in business for himself, in this city, next month.

George Daly, John Kinney, Richard Hanley and Felix McGovern, arrested on the night of March 6 for attempted burglary of the store of Kolomon Bertl, as described at the time in THE CIRCULAR, were placed on trial in the quarter Sessions Court on Thursday morning. Numerous witnesses were called, and the four prisoners were convicted in a very short time. They will be sentenced next week.

In the Court of Quarter Sessions on Friday morning, the trial of G. C. Kerr, until recently bookkeeper of the Riley-Klotz Mfg. Co. was brought up, but on motion of his counsel the case was postponed. The counsel's plea for postponement was that there was a case pending in the Circuit Court, in which the same transactions are involved. Kerr is accused in three indictments of embezzling funds of the company to the amount of \$1,618.14.

Lancaster.

Arthur Bemis, formerly a watchmaker of this city, committed suicide last week at Canton.

Geo. Nauman, of this city, has issued executions for \$1,159.53 against the company, on judgments secured by Abram Bitner, but transferred to H. S. Gara.

After the sale of the Lancaster watch factory had been adjourned, Mr. Patterson, the assignee, sold to Bowman & Musser, of this city, \$5,000 worth of finished material.

Osborn & Co., who have been extensive manufacturers of metal umbrella heads, have decided to give up this line to a great extent, and go into the manufacture of silver hollow-ware. They employ at present, one hundred and fifty hands and have already turned out several patterns. H. E. Osborn, the senior member of the firm, is well known throughout the trade.

Chicago.

H. J. Fogh, 71 E. Chicago Ave., is advertising his business for sale.

R. Thompson, of H. Glorieux & Co., Newark, N. J., was in town last week.

J. S. Gratz, the Madison St., jobber, is on the road through Michigan and Wisconsin.

C. D. Peacock returned last Monday after a three weeks' absence at the Hot Springs, Ark.

William Hirsch, of A. Hirsch & Co. will sail for Europe from N. Y. on *La Bretagne* on May 2d. He will be gone about two months.

It is said that President Avery and J. M. Cutter, of the Elgin National Watch Co., will shortly make a trip together to California in the interests of their company.

G. W. Reynolds, carrying a line of mounted diamond goods for Dutee Wilcox & Co., Providence, R. I., was seen upon State St. during the past week looking very peaked after a protracted illness in Cincinnati.

The Chicago Case Mfg. Co., of this city were incorporated last Tuesday, to manufacture optical goods and cases for the same. The capital stock is \$1,000; incorporators, M. I. Beck, C. T. Frason and L. P. Wilcox.

S. C. Payson, Chicago, of the Courvoisier-Wilcox Mfg. Co., is the treasurer of Masconah Kennel Club. His official position compels him to handle all the funds that were taken in at the recent Bench Show in this city.

C. F. Happel & Co., the old firm of Chicago jobbers, will take possession of their new quarters at 88 State St. this week. This firm has been in existence thirty years, and in the location they are vacating since the big fire of 1871.

Marcus Morton, Secretary of Manufacturing Jewelers' Board of Trade of Providence, was in town last week. His visit was in relation to the Ehrlich Bros.' assignment. He had previously paid Cleveland a short visit in the interest of his Board.

R. A. Kettle, Chicago agent of the American Waltham Watch Co., enjoyed a very pleasant few days' trip with Marvin Hughitt, Jr., Gen'l Traffic Manager of the Chicago & North-Western Ry. The trip was made in Mr. Hughitt's private car, and the party had a most delightful time.

A. Kaempfer, 150 W. Madison St. who was burned out on the 12th inst. has secured quarters at 336 on the same street which he will take possession of about May 1. At this writing he has been unable to get at his safes, which are in the bottom of the basement covered with the ruins.

The following are some of the buyers in town during the week: Henry Plumb, Des Moines, Ia., H. L. Rosencrans, Milwaukee, Wis., Aug. Bruder, Fort Wayne, Ind., W. L. Winslow, Ironwood, Mich., H. L. Dow, Libertyville, Ill., J. L. Nichols, Trenton, Wis., and A. W. Field, Illiopolis, Ill.

Expressions of discontent are heard among the trade through the amount and frequency

of some of the recent assessments of beneficial associations that cater to the jewelry fraternity. Although no names are mentioned the trade will readily understand what organizations are meant. No doubt the present condition of business with the prevailing scarcity of money makes an assessment feel a hardship.

W. H. Gleason, of C. H. Knights & Co., has gone to the city of Mexico in the interests of the firm, who have already what a trade in the Mexican capital. Mr. Gleason has gone down to see about increasing it. It is only since January 1 last that he has taken any active interest in the business of his firm. C. H. Knights leaves for Europe about May 15, to be absent about two months visiting the diamond and other markets.

Another Case of Blue Diamond Swindling.

CHICAGO, Ill., April 16.—Quite a diamond swindling scheme was aired in the Circuit Court last week. The original transaction dates back two years. T. W. Phillips, who formerly had had charge of the diamond department of the old firm of N. Matson & Co., but who at that time was engaged in the real estate and loan business, was approached by a casual acquaintance made while in Matson & Co.'s, and solicited to make a loan on some diamonds.

The next day the party called with the alleged gems, and after an inspection, half of the amount of the purported worth of the stones was advanced. In a few days another chap called with a letter of introduction from No. 1 with another lot of gems, on which half of their value was paid over. In a few days a third party called, and he got what he wanted. Then another owner of gems called, and Mr. Phillips, taking his check book and the stubs, showed that he was the possessor of about \$10,000 worth of alleged gems, on which he had advanced about \$5,000.

Mr. Phillips thought that that was sufficient stock for the time being, but told the waiting applicant to call again in a day or two. He procured the diamonds, on which he had already loaned money, and making a careful inspection, thought he detected one that looked "too blue." A few dips of alcohol applied and Mr. Phillips had thrust upon him the fact that he had been loaning money on painted gems, and that he had been swindled systematically by a small army of crooks.

In a day or two as arranged, the last member of the gang called for his ultimatum. He was taken into a private room, the diamonds were dropped into alcohol, and their true character made known. The sharper demanded them back, but Mr. Phillips declined to give up the yellow goods. The man who first negotiated got scared and returned the money, taking back his stuff. The others refused, and the one who had been detected, and whose goods had been held, had Mr. Phillips arrested for robbery.

He was discharged at the hearing, and then the rogues brought suit in the Circuit Court

for replevin and trover. This case, although as stated initiated two years ago, was only reached last week. It was tried before Judge McConnel, and lasted a day and a half before it was sent to the jury to "assess the amount of damages should the Court decide the question of law in favor of the prosecution"; otherwise, the defendant would be entitled to a new trial. The sequel to this novel set-to between the crooks and Mr. Phillips, who is well and favorably known to the trade, is anxiously awaited.

The Missing Montreal Jeweler Found at Last.

MONTREAL, P. Q., April 20.—The body of the missing jeweler Swenson, who mysteriously disappeared early in February, was found yesterday morning under the snow on a suburban road. He had money and rings on his person. Appearances show he was not murdered, nor robbed, but must have wandered away in a state of dementia, and fallen into a snow drift.



Lancaster Hardening Compound, Price 25 Cents.

For tempering Drills, Cutters or any small steel tools requiring a good, hard and tough cutting edge. Directions for use come with each box.

One Expert says:—In nine years' practice at the bench, over half the time of the last four years was spent exclusively on drilling staffs and pivoting. I have, during this time, tried over one dozen preparations and compounds for tempering my drills. For more than a year I have used only the "Lancaster," as I consider it **The Best.**

For sale by jobbers in Tools and Materials. If your jobber does not have it, send 25 cents to us and we will forward, postage paid.

Bowman & Musser,

Importers and Jobbers,

Watches, Chains, Spectacles, Tools and Materials,
Lancaster, Pa.

C. F. HAPPEL & Co.,

* WHOLESALE *

JEWELERS

86 & 88 State Street,
CHICAGO, ILL.

ALBERT S. GAGE.

H. A. WHEELER.

CHARLES C. HILTON.



The Wellington

OPENED SEPT., 1890,

As the Best Located, Furnished, Lighted,
Ventilated and Equipped EUROPEAN
HOTEL in the Country.

Provided with large Fire and Burglar-Proof Vault for Valuables. Steam and Electric Lighted throughout. Rates from \$1.50 to \$3.00 per day for rooms. Suites with baths from \$3.50 upwards. CUISINE UNEQUALLED.

GAGE HOTEL COMPANY, Proprietors,
Wabash Ave. and Jackson St., CHICAGO, ILL.

SOLID ✦ SILVER ✦ COFFEE ✦ SETS.

AFTER DINNER
COFFEE POTS

Odd and Unique Designs.



TURKISH, ✦ MOORISH,
 AND
 OLD ✦ ENGLISH
 DECORATIONS,

With Sugar Dish,
 Tongs and Tray to Match.

GORHAM MFG. CO.,

SILVERSMITHS,

Broadway and 19th St.,

NEW YORK.

ALFRED H. SMITH & CO.,

DIAMONDS,

182 BROADWAY,

COR. JOHN STREET,

NEW YORK.

33 HOLBORN VIADUCT, LONDON, E. C.

New Lights on the McBride & Marcellus Failure.

CLEVELAND, O., April 20.—James Gibbons has resigned as assignee of the McBride & Marcellus Co., and L. M. Sigler, of Sipe & Sigler, has been appointed as trustee for the creditors.

At 10 o'clock Friday morning, D. H. McBride, C. E. Marcellus, Edna L. Medway and Tillie Fitzpatrick appeared in the Probate Court to submit to an examination touching assets alleged by Trustee Sigler, of the McBride & Marcellus Company, to have been by them concealed.

A. A. Stearns represented the creditors, but rather arrayed himself with attorney Beacon for Mr. Marcellus.

Attorney Stearns said he was in no way Marcellus' attorney, but represented eastern creditors who believed in Marcellus honesty. Marcellus had just returned from the East, having secured enough creditors there to vote in O. J. Campbell, the former receiver, as trustee instead of Mr. Sigler at the meeting of creditors to be held April 25. This creditors' meeting was to have been held April 16, but was deferred by the McBride faction on a technicality for fear they would be outvoted and the present proceeding started on the spur of the moment to influence creditors against Marcellus and to produce a theatrical effect.

Mr. Marcellus was the first to take the stand, the other witnesses leaving the room. He stated that he was secretary of the company and had charge of the Cleveland office for about seven months before the failure. His salary he gave as \$75 a month and in close examination admitted that it had been considerably overdrawn, receiving from the company over \$200 each month, and that the finances had been run very loosely.

A pair of earrings, valued at \$175, taken from the stock and presented by Mr. Marcellus to his wife, a valuable stud and ring, and a watch, which he himself wore, furnished the basis of more questioning, the result of which was that he was compelled to give up the jewelry. In the afternoon the questions were directed to bringing out the facts with regard to the Picket claim, and the indebtedness to L. W. Penfield and R. C. Penfield, and the status of certain of the old partnership of McBride & Marcellus, which afterward became a part of the McBride & Marcellus Co. Mr. Goff, attorney for McBride and Penfield, endeavored to show that the funds of the corporation had been used to pay the debts of the partnership.

Miss Medway was put on the stand and was examined as to the methods of book-keeping employed in the business; from what she said, it was gathered that a trial balance was unknown in the store and that accounts were canceled by drawing blue pencil marks through them.

The Marcellus party declare that McBride has boasted that he will ruin Marcellus and that the whole affair is to influence creditors to vote for the retention of Mr. Sigler as trustee, who will protect the Penfield judgment as a preference.

The examination was continued in the Probate Court yesterday morning. Mr. McBride first took the stand. He said that he has been in the jewelry business for seven years. When the firm of McBride & Marcellus was formed, Marcellus put in \$1,000, and McBride \$1,600. When the firm dissolved, they were in debt practically. Their assets were then merged in the corporation, the McBride & Marcellus Co., with a capital stock of \$50,000, with \$10,000 in stock and \$5,100 in cash paid in. Later McBride borrowed \$5,000 and took up more stock.

Miss Tillie Fitzpatrick, clerk in the store was examined as to McBride's dishonesty.

Miss Medway stated that she acted as book-keeper when she had time, and when she had not, the books were neglected. She was supposed to look after the cash also, but it was never kept straight, because five people had access to the cash drawer. The cash realized from the auction sale, three days before the failure, was charged to Marcellus on McBride's cash slip, but not on the books. Whatever was drawn from the cash drawer, was charged on cash tickets, not on the books.

In conclusion a cross examination was conducted in which Miss Medway figured that in addition to the \$700 charge business between Jan. 1 and Feb. 21, the office had done a cash business for \$2,350, exclusive of what McBride had remitted from Akron, namely \$1,900. Miss Medway also said that McBride had overdrawn his account far more than Marcellus often to the extent of \$200 a month.

The case will be brought up again Wednesday morning.

Philadelphia.

Schmidtman & Beck, 618 Chestnut St., dissolved last Friday.

R. Sutherland has bought out the business of William Fisher, 3258 Ridge Avenue.

T. E. J. Engle, Hazelton, this State, was in town last week making extensive purchases.

J. H. A. Davisson will continue his interest in the reorganized firm of J. E. Caldwell & Co. E. J. Chase has been admitted to an interest in the business.

Jules Levy, of the watch case house of Bernard Levy, spent several days in New York last week, disposing of some of his novelties in watch cases.

It is stated that a company of Philadelphia capitalists are negotiating to purchase the Keystone Standard Watch Co. plant at Lancaster, and start the works on a new basis.

In the Supreme Court of Erie Co., New York, Theophilus Zurbrugg has brought suit against Arthur Lawrence of Buffalo, N. Y., for watch cases sold and delivered, to the value of \$617.

Among the city's visitors during the week were W. H. Macdonough, of the Courvoisier-Wilcox Mfg. Co., and T. B. Parker, of Martin, Copeland & Co., New York, and Mr. Clark, of the Derby Silver Co., Birmingham, Conn.

Louis Sickles, of M. Sickles & Son, who is in the western part of Pennsylvania, has written to the firm, announcing a decided change for the better in business. The entire section has been very dull since last fall.

J. J. Bailey, senior member of Bailey, Banks & Biddle, will sail for Europe the later part of this month. G. W. Banks, of the same firm, is now in Europe.

William Alexander pleaded guilty in court the other day to the charge of larceny of a diamond ring valued at \$140, and a diamond stud valued at \$60, the property of W. S. Hamrick, 726 Chestnut St., and was sentenced to eighteen months in the Eastern penitentiary.

Gideon Du Bois, 1522 Sellers St., Frankford, who died last week at the ripe old age of 82 years, though not a jeweler himself was the father of two jewelers, Gideon Du Bois, Jr., whose place of business is 1528 Sellers St., and B. F. Du Bois, of this city. W. H. Thompson, Jr., retail jeweler at 35½ 8th St., is a nephew of the deceased.

A charter was issued in Harrisburg, Pa., on the 17th to the Empire Watch and Jewelry Co., of this city, with a capital of \$20,000. E. W. Howard, Justice Mitchell and F. C. Sullivan are named as Directors. The incorporation of the concern makes possible the continuance of a retail business now conducted by Mr. Sullivan, who has had some serious losses through the pifferings of agents with whom he trusted his goods. The place of business, 1028 Arch St., will probably be stocked with a new line of goods.

Queen & Co. were, on Saturday last, swindled out of a \$60 Kodak camera. A well-dressed man called at the store, and requested that a salesman accompany him to the Continental Hotel with two of the instruments, as he wished to consult some ladies. He took the salesman into the ladies' parlor and then went out, presumably to call the ladies. He returned, saying the ladies were indisposed, and asked if he could take one of the instruments up and show it to them. This he was permitted to do, and the man took the cheaper one and left the room. In a short time he returned and said he would like to show them the other. He took it and did not come back, and now the detectives are looking for him.

The lot of jewelry which David Squires attempted to smuggle into this port, and which was seized by the Custom officials, was sold by United States Deputy Marshall Marple on the 15th, and brought \$1,298. While there were a number of jewelers in attendance, only two made purchases, Harry White, of Wilmington, Del., and W. Galloway, of this city. Mr. White's purchases were two diamond rings, for which he paid \$92; and 10 filled rings for which a nominal price was paid. Mr. Galloway's only purchases were a gold neck chain and five pairs of alleged gold plain earrings, for which he paid the magnificent sum of \$1.00. It was not surprising that jewelers fought

shy of the stuff, when it is considered that the list of articles which were sold for \$1,298 consisted of the following: 19 diamond rings, 1 diamond bracelet, 1 diamond scarf pin, 1 diamond stud, 1 emerald ring (which brought \$50), 6 gold watches, 1 scarf pin, 7 plated chains, 1 gold neck chain, 3 garnet crosses, 2 gold watch pendants, 10 filled rings, 8 crown rings, 5 pairs gold (?) earrings, 3 pairs plated ear-rings, 5 breast pins, 4 seal and 3 turquoise rings, 7 watch charms, 1 pair Rhine stone earrings, 1 gold locket. The highest price paid was \$149, for the diamond bracelet, and the lowest was 50 cents, for 5 breast pins.

J. R. White, of the J. R. White Jewelry Co., 158 N. 5th St., was held under \$600 bail by Magistrate Clement, on the 18th, to answer a charge of assault and battery preferred by Mrs. Murtha Stanton, of Whightsville, a suburb of Camden, N. J. Mrs. Stanton alleges that before Christmas she bought a ring, guaranteed to be of 14 karat gold, from Mr. White, but it made her finger sore and she took it back. On Wednesday last at request of White, she said, she took the guarantee, to get her money, but he offered to make another ring, and finally gave her \$5. Before she could take the ring from her finger, the woman alleges, Mr. White choked her, struck her twice on the breast, and threw her against the counter, claiming that she intended to steal.

Cincinnati.

Mr. Solar, of E. & J. Schweikert, came home last week sick.

F. A. Averbeck, of the H. Keck Mfg. Co. has returned from the road.

E. A. Cross, of the Columbus Watch Co., Columbus, O., was in town last week.

J. C. Dueber was in town last week to meet some bidders on his Newport factories.

The Cincinnati Aluminum Co. are introducing silicon bronze wire for railway signal service.

J. H. Cole, of Waite, Thresher & Co., Providence, R. I., was a traveler in town Friday.

Clemens Hellebush had the honor, last week, of filling the order of Mayor Mosby, for a complete outfit of silver of about thirty pieces.

Homan & Co. received a \$1,100 order last week, from a Maiden Lane firm. This looks as if they were walking right into the county seat of their competitors.

Some of the prominent houses are considering the early closing subject. The warm rays of the sun have melted the most obdurate heart, and by May we may fall into line.

Jos. Wahl, formerly with W. Nagel, of Paducah, Ky., was in the city buying stock and fixtures for his new store at Paducah. G. Gallup, Catlettsburg, Ky., was also in town.

Jacob Dorst, of Jonas, Dorst & Co., went, last week, to Fort Wayne, Ind., to call on his old friends. Messrs. Jonas and Jepson

will start out this week. They are anxious to show the trade the beauties they have in their new samples.

L. F. E. Hummel is one of the most enterprising jewelers in the Arcade. He has shown his progress by erecting a fine Howard street clock six feet in height, suspended above his doors. It is in ebony and gold, and cost several hundred dollars.

The Executive Committee, of the Ohio Watchmakers' and Jewelers' Association, consisting of Ed. Lohmeyer, L. F. E. Hummel and H. H. Mithoefer, will hold a meeting this week, for the purpose of drafting new resolutions whereby the membership may be enlarged and otherwise benefited.

Duhme & Co. are noted for novel window displays. Last week the curious public were treated to a trip through their factory by means of a window scene. In the background silver bars, sheets and various dies were shown. In one corner there was a pile of trimmings and sweepings. In front, the spoons etc., were shown in various stages of manufacture, from the rough cut to the last bright finish. The crowds around the window at times were so great as to make it difficult to pass.

Boston.

H. A. Carr, of D. C. Percival & Co., is recovering from a severe illness.

W. P. Hitchcock started Saturday on an extended Western trip for Henry Cowan.

The Jewelers' Club is preparing for a banquet in May. The exact date is not yet decided upon.

Among the buyers in town last week, were B. E. Cook, Northampton, Mass., and P. E. Poulin, Quebec, P. Q.

Salesmen in town during the past week were: J. F. Friedman, of the Fidelity Watch Case Co., L. W. Sweet, of the Cheshire Watch Co., and F. S. Sherry, of Jos. Fahys & Co., New York.

A. D. Cairns & Co. will move about May 1st to more convenient quarters in the building at the corner of Franklin and Washington Sts., on the same floor with the new office of the Bay State Watch Case Co.

John L. Nudd, formerly with D. C. Percival & Co., of this city, and since January in the employ of E. H. Saxton & Co., Washington, D. C., has associated himself with a nephew of the late D. M. Tyler, of Ipswich, under the firm name of Nudd & Tyler, at Amesbury, this State.

The Bay State Watch Case Co., whose office is now up three flights in the same building with their workrooms, have secured a handsome and convenient office room up one flight in the building at the corner of Washington and Franklin Sts., which they will occupy about May 1. The company will then be nearer the heart of the jobbing district and much more accessible.

A large amount of jewelry and other articles, supposed to have been stolen, are at

police headquarters in Pemberton Sq., which Chief Inspector Eldridge would like identified. The property was discovered by headquarters' inspectors, last week, at the South End, with a lot of other property which had been stolen and which has been identified.

A number of jewelry men were present at the wedding of the daughter of D. C. Percival last Wednesday evening, among them being Dean Southworth, C. F. Morrill, H. W. Patterson, F. H. Pope, W. E. Cocker, F. M. Swan, H. B. Williams, H. H. Hilton, T. S. Davis, Boston, L. W. Sweet and F. S. Sherry, of New York, T. F. Fessenden and E. W. Martin, Providence, R. I., Hugo Beil, Lawrence, Mass., F. H. Coffin, Peterboro, Mass., A. M. Mossman, Hudson, Mass.

In the window of the jewelry store of C. W. Beals, 11 Milk St., is an ancient time-piece of the Greek temple pattern, with mahogany base bronze trimmings and pillars of alabaster, the whole surmounted by a French eagle, gilded. It stands about two feet high, the clock proper being about the size of an ordinary nickel alarm of the present day. This clock, valued at \$100, was once the property of Louis Philippe, and was used by him in the Salem St. Academy in this city, where he kept a French school during his involuntary exile from his native land. It was given by the King to his housekeeper, previous to his being called to the throne of France, and the present owner, a Boston physician, purchased it from her nearly half a century ago. It is a one-day clock and was made in France, but bears neither name of maker nor date of manufacture. It keeps accurate time.

Syracuse.

Geo. E. Wilkins is in New York for a brief visit.

Jos. Seymour Sons & Co. have just received a complete line of celebrated Norwegian silver, having both the plain and transparent enameling. This firm have been appointed sole agents in the United States for this ware. Charles Seymour, of the firm, started yesterday for an extended trip through the West, to introduce this ware.

E. B. McClelland has prepared a room in the upper part of his block for the display of cut glass. Against the walls on either side are tables, covered with spotless linen. The walls have an ingenious arrangement of mirrors in white frames, which reflect the choice cut glass, and electricity, as a means of lighting, assists in the dazzling effect. The upper walls are in terra cotta effects, making a charming contrast and serving to emphasize the brilliancy of the glass.

The firm of H. W. Graber, Brenham, Tex., composed of Pauline Graber and R. E. Graber, was last week dissolved by mutual consent, Pauline Graber retiring. R. E. Graber assumes all the liabilities.

THE JEWELERS' CIRCULAR AND HOROLOGICAL REVIEW.

PUBLISHED EVERY WEDNESDAY BY

THE JEWELERS' CIRCULAR PUB'G CO.,
AT NO. 189 BROADWAY, NEW YORK CITY.

A JOURNAL DEVOTED TO THE INTERESTS OF
WATCHMAKERS, JEWELERS, SILVERSMITHS,
ELECTRO-PLATE MANUFACTURERS AND ALL
WHO ARE ENGAGED IN KINDRED BRANCHES
OF INDUSTRY.

Terms of Subscription, Postage Prepaid.

	PER ANNUM
United States and Canada, - - -	\$2.00
To all Foreign Countries, - - -	4.00
Single Copies, - - - - -	.10

ADVERTISEMENT.

Business letters, drafts, checks and post-office orders should be addressed to THE JEWELERS' CIRCULAR PUBLISHING COMPANY, No. 189 Broadway, New York city.

Manuscript from any quarter containing news or discussion of any technical subject within the field covered by THE CIRCULAR will be welcomed. Matter received that proves unsuitable or unavailable will be returned if accompanied by the necessary postage stamps.

Our editorial columns will contain our own opinions only, and we shall present in other columns only what we consider of interest or value to our readers. Applications to print advertising matter as news will not be considered.

Advertising rates in THE CIRCULAR are lower, considering the number of tradesmen reached by its large circulation, than in any other jewelry journal.

Notices of changes in standing advertisements must be received one week in advance, new matter can be received up to Saturday.

Member of the American Trade Press Association.

VOL. XXII. APRIL 22, 1891. No. 12.

Diamond Cutting in America.

It is gleaned from a Census Bulletin of precious stones and diamond cutting, issued last week by the Department of the Interior, that there are in New York sixteen firms, and in Massachusetts three firms engaged in cutting and recutting diamonds. The business has also been carried on at times in Pennsylvania and Illinois, but has been discontinued. In 1889 seven of the New York firms worked full time, but the others were unemployed respectively 14, 50, 61, 120, 125, and 240 days, owing to the inability of obtaining rough material at a price at which it could be cut with profit. The Bulletin further says, that the firms that were fully employed were generally the larger ones, whose business consisted chiefly in repairing chipped or imperfectly cut stones, or in recutting stones previously cut abroad, which owing to the demand in this country for superior workmanship, could be recut at a profit; or in recutting very valuable diamonds, with the certainty that the work could be done under their own supervision, thus guarding against any possible loss by exchange for inferior stones. The industry in 1889 gave employment to 236 persons, who received \$148,114

in wages. Though these figures and facts do not astonish us by their ponderance, yet while human nature remains the same and unprincipled dealers thrive, no better tariff laws than the existing ones can be promulgated to increase the diamond-cutting industry in America.

Valuation and the Law.

LESS than two months ago the Courts at Louisville, Ky., decided that a certain woman, charged with obtaining money by false pretences by passing off painted blue diamonds for genuine white ones, was technically innocent of the charge, and though known to be a sharper, she was dismissed. The court held that the case was one of valuation only, the merchant who bought the stones being presumed to know his business. Had she passed off another kind of thing as a diamond, she would have been guilty. A similar case is now on the tapis at Chicago, Ill., though by a freak of chance, the tables are turned, the party who was swindled being the defendant. The operations of the plaintiffs stamp them as sharpers. The defendant is an honorable man, favorably known in the jewelry trade. Swindled of several thousands of dollars by purchasing false stones, with no ability to obtain redress from the Courts, the jeweler retains a number of stones, the purchase of which he was contemplating, and appears in court as a defendant, sued by his swindlers. It is giving a premium on chicanery and fraud to hand down decisions such as that at Louisville, and it seems that the States should enact some statute meeting the harassed jeweler, in such cases, half way.

No Coins In Jewelry.

TRULY the life of a jeweler should not be a happy one. While serving a customer in broad daylight he is approached by men who pilfer his cases at the point of a revolver; while sleeping the sleep of the just, his stock is carried off; while behind his counter, his show window is smashed and his stock robbed; he is approached unceasingly by pennyweighters, diamond lickers and swallows, red eyed old men, and swindlers of established and original processes; he is sandbagged, has red pepper thrown into his eyes, is shot at, pounded, and otherwise assaulted. His legitimate business is interfered with by the operations of peddlers, fakirs, watch lotteries, gift enterprises, inconsiderate notion and fancy goods houses, itinerants and cheap Johns generally. And now the National Legislature steps in and cuts off a source of profit that is not to be thought lightly of. Under a law which was passed just before Congress adjourned, the manufacture of an article embodying a coin is rendered illegal, and the person who offers it for sale is liable to a fine of \$100. This new statute is one of the most stringent of its kind ever enacted. Its main purpose, it is said, is to cure a fatal defect in the old

law, it having been impossible hitherto to punish the makers of the dies and molds used by manufacturers of toys and novelties which are facsimiles of paper notes and gold and silver coins. Now anyone who makes a die or mold in imitation of the coin of the United States, and anyone who uses imitations of United States or foreign coins for any purpose, may be convicted and punished. The embodiment of coins or imitations has produced numerous successful novelties in jewelry and trinkets. As the foundation of success of a jewelry manufacturer depends largely upon his ability to produce popular novelties, and the success of the retailer upon the novelty of the goods he offers his customers, the trade will look with disfavor upon this new law which limits their field of thought and profit. Still the statutes of Congress are the law of the land, and must be abided by. And when we consider that while the jewelry trade is somewhat adversely affected by the new law, the likelihood of the general public being hoodwinked by nefarious operators is reduced, we must admit the law to be a good one, when we accept it in its broadest sense.

The Week in Brief.

There was no bid for the Lancaster Watch plant.—A garnet mine was discovered at North Creek, N. Y.—The agent of the Chicago W. & J. Co., Newark, N. J., fled from that city.—The burglars of Frank Hoffa's store, Washington, D. C., were sentenced.—Raabe Bros., San Diego, Cal., were burglarized.—Allen Owen, Almo, Ind., and Albert Bemis, Lancaster, Pa., committed suicide.—A romance in business life was consummated in New York.—David Mayer, Hartford, Conn., brought suit against C. G. Moore, Holyoke, Mass., for \$2,500.—Herbert Hagg, Carey, O., committed suicide.—Luciano Fabbriotti, New York, and George O. Hermann, Newport, R. I., died.—Conflagration burnt out several factories in the New York trade.—The window of J. B. Roos, St. Louis, Mo., was smashed.—J. Steinmetz Jewelry Co., Helena, Mon., made a temporary assignment.—The first burglary of a Providence, R. I., jewelry factory in ten years took place.—Many Providence R. I., jewelry firms dissolved.—It was decided at St. Paul, Minn., that watch clubs are lotteries.—Horace Mariotte, Fort Wayne, Ind., was robbed.—L. Jackson, Norwalk, Conn., was robbed of \$15,000 worth of stock.—The body of the missing jeweler Swenson, of Montreal, P. Q., was found.—Another case of blue diamond swindling came up at Chicago, Ill.—The sale of the stock of Sumner Bros., Cleveland, O., was consummated.—Otto Young, Chicago, Ill., resigned from the World's Fair directory.—Executions were entered against Hollinshed Bros., Philadelphia, Pa.—The Sheriff took possession of Charles Davis' store, Cleveland, O.—J. L. Friedman's store, Paducah, Ky., was burglarized.—Louis Friedlander, New York, was married.

New York Notes.

Henry Zimmern has had his store refitted and decorated.

W. W. Fairchild intends moving from 41 Maiden Lane to 176 Broadway.

Jos. Fahys & Co. have entered a judgment against John Reiger for \$72.55.

A judgment for \$152.40 has been obtained against W. Boettcher by the Ansonia Clock Co.

Morris Weil, will, on May 1, move from Room 21 to 31 in the Knapp Building, 41 Maiden Lane.

The Gustave Walter Optical Co. will shortly move from 14 Maiden to the store at 53 Maiden Lane.

H. H. Jacobson, of Jacobson Bros., will sail for Europe shortly to make diamond purchases for his house.

Horwitz & Hershfield have moved from 417¹/₂ Grand St. to Nassau St., where they share the first floor with the United States Watch Case Co.

Many old European war medals were among the articles sold at the auction sale of the Doughty collection, conducted by Bangs & Co., at 739 Broadway, last Thursday.

S. E. Zimmern has entered a judgment against Edmund Heinecke, 29 E. Houston St., for \$25, in the suit decided against the latter in the City Court last week, the trial of which has been published in these columns.

H. A. Lambert, of Aikin, Lambert & Co., returned last week from an extended trip through Florida. Mr. Lambert owns several orange groves at Leesburg, Fla., and after transacting some business at that place he visited many other cities of the South.

Edward Wall, alias Whalen, alias Wheeier, who last year was released from prison after serving a term of imprisonment for robbing jewelry stores of this city, was arrested last Thursday, and held for extradition. He is "wanted" at Lynn, Mass., for burglary.

Henry Zulick, said to be employed in a jewelry workshop in this city, was arrested last Friday in Brooklyn while engaged in posting placards calling for an indignation meeting to denounce the "Pittsburg blood verdict." He was held for examination.

B. S. Wise, 39 Union Sq., was married last Tuesday evening at Sherry's, on Fifth Ave., to Miss Leonora Hein. Over one hundred and fifty guests partook of the wedding dinner, and joined in the dance that followed. Among those present were C. T. Cook, of Tiffany & Co., Mrs. L. Lannenbaum and Sig. Hirschberg.

The electro plating workshop of Martin Brunor, in the rear of 23 John St., was badly damaged by fire last Tuesday evening. The blaze occurred shortly after six o'clock, and many jewelers who were on their way home on hearing of a fire in the jewelry district hastened back to their offices in alarm. The fire, however, was extinguished after five minutes work by the firemen.

The death of John P. Fellows, which was

published in the last issue of THE CIRCULAR several days in advance of any other paper, has occasioned a change in Fellows & Co. The firm will now be continued under the style, Hills & Whitbeck. G. K. Whitbeck had been an associate with Mr. Fellows for many years, and P. K. Hills, Jr., was formerly connected with the Gorham Mfg. Co.

This afternoon W. F. Knowlton, a salesman for the Morgan Silver Plate Co., Winsted, Conn., will be arraigned for trial in the Adams St. Police Court, Brooklyn, on the charge of grand larceny preferred by J. T. Morgan. It is claimed that on Sept. 26, 1890, he collected \$63 for his employers from Frederick Begeman, 494 Broadway, Brooklyn, but never turned the money over or reported the collection.

Michael Sheba, 119 Washington St., is looking for a missing wife and missing money. Recently one of his peddlers, named Basha, sold out his stock at Troy, and sent the money down to Mr. Sheba by a fellow countryman who kindly volunteered to perform that office. The friend, however, also took Sheba's wife, and Mr. Sheba has not seen his money, Basha or his wife since.

F. S. Baker, New York representative of the United States Watch Co., has cautioned R. J. Magee, 53 Nassau St., against using the name of his concern in his business. Mr. Magee advertised in several newspapers under the name of the "United States Watch Co." Last Thursday President Eaton, of the United States Company, came to New York, and placed the matter in the hands of an attorney.

There was an exhibition at the store of the Whiting Mfg. Co., last week, what is said to be the most complete silver service ever manufactured in America. The articles were made for a wedding present to an American heiress, presented by her titled husband, and some time this week they will be shipped to the couple's home in Germany. The silverware is contained in seven brass-mounted oak cases, and comprises over 700 pieces, including every article needed for twenty guests. Its value is said to be over \$20,000. The pattern is severely plain, the design being after the Louis XIV. period. Each piece, from the smallest coffee spoon to the tall candelabra, contains the couple's initials and their coat of arms. During the week the magnificent service was viewed by hundreds of persons.

JEWELERS ATTENTION!

DO YOU KNOW that we are making the only line of cuff buttons which are sold exclusively to the RETAIL JEWELRY TRADE?

DO YOU KNOW that the action or fastening of this button is the simplest, most durable and most salable of any in the market?

DO YOU KNOW that we are manufacturing a full line of these buttons in roll plate, gold front and solid gold?

DO YOU KNOW that this line of buttons was endorsed and recommended by the OHIO RETAIL JEWELERS' ASSOCIATION?

DO YOU WANT a line of cuff buttons which is not found in any Dry Goods, Gents' Furnishing or Millinery Store in the country—thereby preventing such ruinous competition?

Then send to us for a selection of our "**ANTI-SWEAR**" Buttons

J. T. SCOTT & CO.,

SOLE MANUFACTURERS,

4 MAIDEN LANE, - NEW YORK.

The attaching creditors of Stern & Stern last week made a motion before Judge Beach to allow their suits against the judgment creditors to go to the General Term without filing a bond.

J. S. Leviness, Saturday, sold at private contract 30 Maiden Lane, occupying only three-fifths of a full city lot, at \$100,000. This is considered the highest price ever paid for Maiden Lane property.

A. Pinover & Co., manufacturing jewelers, will remove from Ann St. to 42 and 44 E. Houston St., on May 1st. Their facilities will be largely increased, and more ample accommodations for doing business will be had at their new location.

Last week the F. Kroeber Clock Co., replevined about \$250 worth of clocks from the store of Viemeister Bros., Greenpoint, L. I. The City Constable, however, claimed that the property was in his hands by virtue of a writ of execution, and the matter was aired in Justice Engle's Court last Monday. Judgment was reserved.

Among the departures last week for Europe were Mr. Maynard, of A. Stowell & Co., Boston, Mass., on the *Lahn*; Leopold Stern, of Stern Bros. & Co., and David Untermeyer, of Keller & Untermeyer, New York, and J. B. Mayer, Buffalo, N. Y., on the *Havel*; L. J. Glaenger, New York, on *La Normandie*, H. E. Oppenheimer, of H. E. Oppenheimer & Co., New York, will sail on the *Trave* today. Among the arrivals were Justus Heilbronn, of Heilbronn & Blank, New York, on *La Normandie*.

The trade is cautioned against a man described as being about 45 years of age, five feet eleven inches in height, slim build, small moustache and very nervous in manner. He has applied to several Maiden Lane firms for goods, claiming that he represented J. A. Spencer, of Norwalk, Conn. In one instance he purchased some jewelry which was sent to the Norwalk firm. On receipt of the package they saw through the attempted swindle and telegraphed to the Maiden Lane firm that he was a fraud, and had no connection with their business.

The Week's Arrivals.

The following out-of-town dealers were registered in New York during the current week: R. H. Parker, Boston, Mass., Murray Hill H.; J. A. Wood, Boston, Mass., Devonshire H.; E. M. Bacon, Boston, Mass., Westminster H.; E. R. Rand, Boston, Mass., Gd. Union H.; W. D. Walker,

Chicago, Ill., Windsor H.; G. A. Weber, Chicago, Ill., Astor H.; J. W. Webb, Dallas, Tex., Astor H.; F. G. Pratt, Boston, Mass., Astor H.

Hymen Visits Louis Friedlander.

Louis Friedlander, of R. & L. Friedlander, 65 Nassau St., New York, was married last Monday to Miss Ida Cohn. On April 10, in honor of the event, he was tendered a farewell dinner by his bachelor friends at the Freundshaft Club house which was beautifully decorated for the occasion. Speeches were made by Messrs. Friedman, Strauss, Elkers, Livingston, Popper and Reinheimer.

The principal event of the evening was the address of Mr. Friedlander. He said that he

looked upon the evening as the happiest of his life. He confessed that his newly acquired happiness was tempered with feelings of regret that he must leave the merry bachelor circle but that there was the consolation in any event, that it did not deprive him of the membership of the club. He quoted the old proverb, "Every wedding makes another, sooner or later," and wondered who would be the next Benedict among those present.

The wedding was private, only relatives and a few intimate friends being present. After the ceremony the couple left for the South, and will remain away about two weeks. Mr. Friedlander is an active member of several social athletic and commercial clubs, and takes a great interest in charitable and religious institutions.

DORFLINGER'S AMERICAN CUT GLASS.

The Finest Crystal, Plain and Cut, made in the World.



EVERYTHING that is used in Glass, for the Table.

BEAUTIFUL, Artistic and Useful Pieces for Gifts.

Sells as well as Silver-ware.

Rivals the Diamond for Purity and Lustre.

EVERY FIRST-CLASS JEWELER C. DORFLINGER & SONS,

SHOULD KEEP IT. 36 Murray Street, New York.



KEY-WINDING WATCHES MADE STEM-WINDERS.

Over forty thousand American Watches (men's sizes) have been altered to stem-winders by means of ABBOTT'S PATENT STEM-WINDING ATTACHMENTS.

HENRY ABBOTT, MANUFACTURER, 4 MAIDEN LANE, NEW YORK. Remove May 1st to No. 14 Maiden Lane.

"BUNYANKA"

The best seamless wire, gold soldered chain in the market. Only slight advance over plated prices. Warranted for ten years.

E. H. SAXTON & CO., 58 Winter Street, Boston, Mass.

SEND FOR SAMPLE DOZEN.

SEE PAGE 38.

BUY MYERS' MAINSPRINGS,

\$15.00 Per Gross.

M. MYERS, 7 Bromfield St., Boston, Mass.

CLASSIFIED INDEX TO ADVERTISEMENTS.

All Advertisements are entitled to one insertion under proper heading. Extra insertions, \$6.00 per Annum. Extra Headings \$12.00 per Annum.

Assayers & Refiners.
Howard, S. P., 8 John st., N. Y. 48
Lelong, L., & Bro. 48
Platt, C. S., 29 Gold st., N. Y. 48
Robertson & Leber, 13 Franklin st., Newark, N. J. 42

Auctioneers.
Comrie, A. J., 16 West 125th st., N. Y. 36
French, J. H., Box 2775, N. Y. 47

Badges, Medals, etc.
Stockwell, E. R., 13 John st., N. Y. 14
Braxmar, C. G., 47 Cortlandt st., N. Y. 41

Black Onyx Jewelry.
Woglom, Gilbert T., 32 John st., N. Y. 40

Books, Stationery, etc.
Pamphilon, H. W., 30 Bond St., N. Y. 47
Dickie, W. B. 67

Clock Manufacturers.
Parker & Whipple Co., Meriden, Conn. 47

Cut Glass.
Dorflinger, C. & Sons, 36 Murray st., N. Y. 27
Phoenix Glass Co., 720 Broadway, N. Y. 53
Mt. Washington Glass Co. 38

Diamond & Precious Stone Importers.
Fera, Henry, 48
Gunzburger Bros., 15 Maiden Lane, N. Y. 35
Hedges Win. S. & Co., 170 Broadway, N. Y. 30
Kahn, L. & M. S. Co., 10 Maiden Lane, N. Y. 48
Kipling, E. E., 2 John st., N. Y. 48
Kipling, R. A., 31 Union Square, N. Y. 37
Lorsch, A. & Co., 37 Maiden Lane, N. Y. 48
Oppenheimer Bros., & Veith, 35 Maiden Lane, N. Y. 35
Rande, Baremore & Billings, 29 Maiden Lane, N. Y. 13
Smith, Alfred H. & Co., 182 Broadway, N. Y. 24
Taylor & Bro., 860 Broadway, N. Y. 14
Wheeler, Hayden W. & Co., 2 Maiden Lane, N. Y. 35

Diamond Cutters.
Groenman, A. J. & Co., 80 Nassau st., N. Y. 16

Diamond Jewelry.
Bynner, T. B., 177 Broadway, N. Y. 16
Falkenau, Oppenheimer & Co., 49 Maiden Lane, N. Y. 48
Nissen, Ludwig, & Co., 18 John st., N. Y. 44
Peckham, Chas. H., 63 Nassau st., N. Y. 13
Sexton Bros. & Ashburn, 41 Maiden Lane, N. Y. 39
Stern Bros., 42 Maiden Lane, N. Y. 30

Engravers and Designers.
Bartholomev & Peckham, 18 Spruce st., N. Y. 14
Beecher & Clark, Louisville, Ky. 30
Goldstein, J. A., Washington, D. C. 37
Park, Wm., 27 John st., N. Y. 3
Ryder & Dear, 146 Westminster st., Providence, R. I. 45, 37

Eye Glass Holders & Chains.
Merritt, S. F., Springfield, Mass. 40

Gold and Silver Platers.
Newman, Louis, Jr., 37 John st., N. Y. 40
Jeandheur Bros., Newark, N. J. 41

Gold Jewelry.
Bippart & Co., Newark, N. J. 21
Carter, Sloan & Co., 15 Maiden Lane, N. Y. 39
Cottle, S. Co., 860 Broadway, N. Y. 40
Day & Clark, 10 Maiden Lane, N. Y. 9
Kremetz & Co., 182 Broadway N. Y. 33
Larter, Elcox & Co., 41 Maiden Lane, N. Y. 13
Moore & Horton, 11 Maiden Lane, N. Y. 14, 12
Riley, J. A., & Sons Co., 860 Broadway, N. Y. 15
New & Westcott, 1 Maiden Lane, N. Y. 3
Street, Geo. O. & Sons, 15 John st., N. Y. 37

Gold Chains.
Rickert & Stiehle, Newark, N. J. 14

Horological Schools.
Elgin Horological School, Elgin, Ill. 16
Jaegman, R., St. Louis, Mo. 36
Waltham School of Horology, Waltham, Mass. 20

Hotels.
Russell House, Detroit, Mich. 14
Hotel Wellington, Chicago, Ill. 23

Imported Clocks, Bronzes, Etc.
Jacques, Chas., & Co., 2 Maiden Lane, N. Y. 43

Jewelry Repairers.
Wiederhold, A., 20 Maiden Lane, N. Y. 44

Jewelry and Silverware Cases.
Jackson, S. C., 180 Broadway, N. Y. 41
Wiggers & Froelick, 60 Nassau st., N. Y. 46

Jobbers, Watches, Diamonds, etc.
Aikin, Lambert & Co., 23 Maiden Lane, N. Y. 14
Beguelin, Tell A., 71 Nassau st., N. Y. 40
Bowman & Musser, Lancaster, Pa. 23
Cross & Beguelin, 21 Maiden Lane, N. Y. 19
Friedlander, R. & L., 65 Nassau st., N. Y. 40
Happel, C. F. & Co., Chicago, Ill. 23
Koch & Dreyfus, 22 John st., N. Y. 38
Myers, M., Boston, Mass. 27, 38
Myers, S. F. & Co., 48 Maiden Lane, N. Y. 48
Saxton, E. H. & Co., Boston, Mass. 27
Scott, J. T. & Co., 4 Maiden Lane, N. Y. 26
Whitney, E. A., Boston, Mass. 12
Wilson, E. F. & Co., Boston, Mass. 42

Lamps.
Eakins, G. & Son, Philadelphia, Pa. 44

Musical Boxes.
Jacot & Son, 298 Broadway, New York 40

Optical Goods.
Geneva Optical Co., 23 Washington st., Chicago, Ill. 20, 36, 39
Levy, Dreyfus & Co., 11 Maiden Lane, N. Y. 41
U. S. Optical Co., Detroit, Mich. 36
Zineman, M. & Bro., Phila. 9, 15

Order Work.
Maxheimer & Beresford, 3 Maiden Lane, N. Y. 39

Pens, Pencil Cases, Etc.
Aikin, Lambert & Co., 23 Maiden Lane, N. Y. 14
Smith, H. M. Co., 83 Nassau st., N. Y. 16

Ring Makers.
Bowden, J. B. & Co., 192 Broadway, N. Y. 10
Bryant, M. B. & Co., 10 Maiden Lane, N. Y. 10
Hildreth Mfg. Co., 51 Maiden Lane, N. Y. 45
Odenheimer & Zimmern, 36 Maiden Lane, N. Y. 48
Ostby & Barton, 80 Clifton st., Providence, R. I. 14

Rolled Plate Chains.
Barrows, H. F. & Co., 1 1/2 A, Maiden Lane, N. Y. 41
Kent & Stanley Co., 7 Eddy st., Providence, R. I. 3

Rolled Plate Jewelry.
Crossin & Tucker, 399 Pine st., Providence, R. I. 40
Foster & Bailey, 60 Richmond st., Providence, R. I. 33
Ludwig, H. & Co., Providence, R. I. 14
Mauson Jewelry M'fg Co., Chicago, Ill. 42
Plainville Stock Co., Plainville, Mass. 40

Seamless Wire.
Burdon Seamless Filled Wire Co., Providence, R. I. 40

Settings & Galleries.
Blancard & Co., 46 John st., N. Y. 40

Silk Guards.
Rosenthal, Wm., 79 Nassau st., N. Y. 33

Silver Plated Ware.
Pairpoint Mfg. Co., New Bedford, Mass. 5

Rogers, Wm., Mfg. Co., Hartford, Conn. 36
Rogers & Hamilton Co. The, Waterbury, Conn. 48
Rogers & Bro., 16 Cortlandt st., N. Y. 11

Stem-Winding Attachments.
Abbott, Henry, 4 Maiden Lane, N. Y. 27

Sterling Silver Novelties.
Alvin Mfg. Co., 860 Broadway N. Y. 9
La Pierre, F. H., 18 East 14th st., N. Y. 16
Lewis Bros., 41 Maiden Lane, N. Y. 19

Sterling Silverware.
Durgin, W. B. 9
Gorham Mfg. Co., 19 st. & Broadway, N. Y. 24
Towle Mfg. Co., Newburyport, Mass. 70
Wallace, R. & Sons, Mfg. Co., 3 Park Place, N. Y. 6
Wood & Hughes, 16 John st., N. Y. 37

Souvenir Spoons.
Alvin Mfg. Co., 860 Broadway, N. Y. 20
Conover, D. F. & Co., Philadelphia, Pa. 5
Cowell & Hubbard Co., Cleveland, O. 32
Durgin, W. B., Concord, N. H. 7
Galt, M. W., Bro. & Co., Washington, D. C. 8
McFarland C. & Co., Worcester, Mass. 8
Newhall, W. F., Lynn, Mass. 42
Simons, Bro. & Co., Philadelphia, Pa. 32
Stowell, A. & Co., Boston, Mass. 39
Wendell Mfg. Co., Chicago, Ill. 12
Whiting Mfg. Co., Union Square & 17th St., N. Y. 4

Tool Manufacturers and Dealers.
American Watch Tool Co., Waltham, Mass. 34
Bullock, O. W. & Co., Springfield, Mass. 20
Nordman Bros., San Francisco Cal. 47
Nicholson File Co., Providence, R. I. 14

Thimbles.
Ketcham & McDougall, 198 Broadway, N. Y. 0

Watch Companies.
Illinois Watch Co., Springfield, Ill. 37
Non-Magnetic Watch Co., 177 Broadway, N. Y. 14
Trenton Watch Co., Trenton, N. J. 44
United States Watch Co., Waltham, Mass. 43

Watch & Clock Dials.
Waltham Dial Co., Waltham, Mass. 14

Watch & Clock Oils
Ginnel, Henry & Co., 31 Maiden Lane, N. Y. 46
Nye, William F., New Bedford, Mass. 41

Watch Keys.
Clark, A. N., Plainville, Conn. 39
Kendrick & Davis, Lebanon, N. H. 44

Watch Case Manufacturers.
Crescent Watch Case Co., 5 Bond st., N. Y. 40
Dueber Watch Case Mfg. Co., Canton, O. 16
Essex Watch Case Co., Newark, N. J. 46
Muhr's Sons, H., 629 Chestnut st., Philadelphia, Pa. 31, 48
Roy Watch Case Co., 17 Maiden Lane, N. Y. 48

Watch Case Repairers.
Feimer, G. F., 9 Bond st., N. Y. 35
Felix, N. J., 71 Nassau st., N. Y. 9

Watch Importers.
Abry, Chas. L., 41 Maiden Lane, N. Y. 38
Didisheim, Hipp, 83 Nassau st., N. Y. 13
Hydes' Sons, John E., 22 Maiden Lane, N. Y. 42
Wittnauer, A., 30 Maiden Lane, N. Y. 45

Watch Materials, &c.
Cross & Beguelin, 21 Maiden Lane, N. Y. 19
Friedlander, R. & L., 65 Nassau st., N. Y. 40
Harstrom, C. G., Peekskill, N. Y. 41
Keller, L. H. & Co., 64 Nassau st., N. Y. 15

Watch Repairers.
Juzek, Thos. & Co., Elgin, Ill. 39
Simmonds, J. C., 18 John st., N. Y. 46

Watch Springs.
Hammel, Riglander & Co., 35 Maiden Lane, N. Y. 38

Special Notices.

Rates 75c. per insertion for notices, not exceeding 3 lines; additional words 2 cents each. If answers are to be forwarded, postage stamps must be enclosed. Two insertions, 10 per cent. off; three insertions, 15 per cent. off; four insertions, 25 per cent. off. Payable strictly in advance.

Situations Wanted.

THE JEWELERS' CIRCULAR has a guaranteed circulation of over 10,000 copies weekly. It is, therefore, the best medium for reaching the trade. To demonstrate this to advertisers, notices in this column will be inserted free of charge during the month of April.

A NICKEL PLATER desires a situation; thoroughly understands the business; can give best of reference if required. Address, Plater B, this office.

DIAMOND LINE WANTED.—Mounted or loose; on salary and commission; by an experienced and reliable salesman. Address, Watson, P. O. Box 3278, New York.

POSITION WANTED.—By a young man in jewelry store as salesman; can also work at the bench; six years' experience; good reference. Address, A. H. T., 54 Berkley St., Taunton, Mass.

SITUATION wanted as clerk in retail, or traveler for wholesale jewelry house; nine years' experience in retail jewelry business; can give best references; New York, Philadelphia or Boston preferred. Address A. B. C., care of THE JEWELERS' CIRCULAR.

SITUATION wanted by a young man as credit clerk; understands position thoroughly, as well as all office work, bookkeeping, etc. Good reasons for wishing to make a change. Address, H., P. O. Box 3306, N. Y. City.

SITUATION WANTED.—By first-class rapid watchmaker, jobber and plain engraver; young man of pleasant address; good set of tools: A 1 reference. Address, G. W. C., 1125 Grand Ave., Pueblo, Col.

YOUNG MAN, twenty years of age, would like a situation with a jewelry or optical house; has had experience in both lines of business; satisfactory references. Address Johnson, care of THE JEWELERS' CIRCULAR.

ENGLISHMAN, able, energetic, seeks position with manufacturer; conversant with every detail; connoisseur of work, diamonds, gems; good salesman and correspondent. Address, Botfield, 1118 Girard Street, Philadelphia.

Help Wanted

WANTED.—Optician and engraver, optician and watchmaker, and engraver who can assist in selling and displaying goods in a large Southwestern city; as engraver, work must be good; only competent men need apply, stating age, salary and references; steady positions are assured the right men. Address, Competent, care of THE JEWELERS' CIRCULAR.

For Sale.

A FINE ship chronometer for sale cheap. Address: A. C. Taylor, Cedar Rapids, Iowa.

FOR SALE.—On account dissolution of partnership, three iron safes; one fine "Herring Patent Champion"; also fixtures, shop tools, etc. Apply to Moore & Horton, 11 Maiden Lane, New York.

ABOUT \$8,000—half cash easy payments on balance, will buy, Wholesale and Retail Jewelry Store, established fifteen years. Best location in City of 350,000. Retiring from business. A bonanza. For particulars, Address, B., Care JEWELERS' CIRCULAR.

FOR SALE—Rare good business opportunity for any watchmaker with \$1,800 cash; good-paying jewelry business, in a rapidly-growing town in Western New York; rent low; good trade and plenty of repairing. Present owner not able to look after it. Address U. S. C., care of THE JEWELERS' CIRCULAR.

Miscellaneous.

OPTICIANS. We offer, very cheap, a brand new surface-grinding lathe, with complete set of moulds + 0.25 Ds to 13 Ds; correspondence solicited. Address, A. Jay, Cross & Co., 18 W. 23d St., New York.

TO MANUFACTURERS of Clock Movements.—Wanted, a good eight-day movement, to fit onyx and marble cases; send particulars and price for quantities to Case Manufacturer, care of THE JEWELERS' CIRCULAR.

WANTED.—On Maiden Lane or vicinity, a window and bench room for a watchmaker. Address, H. L., care of THE JEWELERS' CIRCULAR.

W. F. A. WOODCOCK'S SCHOOL FOR WATCHMAKERS, Winona, Minn., offers unrivaled facilities for acquiring a thorough practical knowledge of every branch of the business. Terms very reasonable.

WORK FOR THE TRADE.—All kinds of watch and jewelry repairing. Skillful workmen, prompt attention and satisfaction guaranteed. Address, A. W. Johanson, 176 & 178 Market st., Chicago, Ill.

FOR JEWELRY OR CLOCK BUSINESS.

VALUABLE BUILDING TO LEASE.

The building now occupied by Parke, Davis & Co., 60 Maiden Lane, running through to Liberty St., can be had on favorable terms from May 1. It is four stories, with a good cellar, 23 feet front by about 100 deep. This is a most desirable location, being very prominent, central and convenient. Apply to JOHN CLAY, on the premises.

ARE YOU ALIVE?

You are not if you don't read.

Are you interested in Notions, Fancy Goods or General Dry Goods? If so, send for copy of "Dry Goods Economist," New York City.

Are you in Boots and Shoes? If so, send for sample copy of "Boot and Shoe Recorder," Boston, Mass.

Are you in Drapery Stuffs, Curtains, Upholstery or Fine Furniture? If so, send for sample copy of "The Upholsterer," Philadelphia.

Are you interested in Gents' Furnishings? If so, send for sample copy of "The Haberdasher," New York City.

Are you interested in Clothing? If so, send for sample copy of "The Clothing Gazette," New York City.

Are you interested in Jewelry? If so, send for sample copy of "The Jewelers' Circular," New York City.

Are you interested in Stationery and its adjuncts? If so, send for sample copy of "Paper and Press," Philadelphia.

Are you interested in Furniture? If so, send for sample copy of "The Michigan Artisan," Grand Rapids, Mich.

Are you interested in export trade? If so, send for sample copy of "The American Exporter," New York City.

All these papers are members of THE AMERICAN TRADE PRESS ASSOCIATION.

Stole \$15,000 in Diamonds.

CINCINNATI, O., April 20.—A brief special from Paducah, Ky., received to-night, gives meagre details of a diamond robbery there. J. L. Friedman, a leading jeweler, was robbed Saturday night of diamonds said to be valued at \$15,000 and a small amount of money. The burglars are believed to be local talent. They secured an entrance through a rear window and made their way directly to where the jewels were left on a dresser.

The Howard Co. Erect a Large Clock.

PHILADELPHIA, Pa., April 15.—The Philadelphia & Reading R. R. Co. have just had erected at Broadway and Chestnut St., in front of their ticket office, a massive pillar clock with four dials. The former time-piece not proving satisfactory in appearance, the E. Howard Clock and Watch Co. contracted to replace it with a specially designed and constructed clock, which is a great improvement over its predecessor. The clock surmounts a massive bronze column, the extreme height of all being twenty-one feet from the curb.

Each of the four faces are three feet in diameter and are of ground glass, on which are painted black numerals to designate the hours. At night a number of electric incandescent lights illuminate the dials from within, these being lighted and extinguished automatically at any hour at which it may be desired, the adjustment being made to conform to the varying length of the days.

The maximum variation is guaranteed not to exceed ten seconds per month.

Romance in Business Life.

A story which reads like a romance culminated last Thursday morning in one of the parlors of the Astor House, New York. Nearly forty years ago, Samuel Daskam, now a selectman of North Norwalk, Conn., was a manufacturing jeweler in Troy, N. Y. Among his employes was an Irish boy named Peter Sheridan, who was a great favorite of Mr. Daskam. Some years later, when the latter was in the jobbing trade on Maiden Lane, he started young Sheridan in business at the corner of Sixth Ave. and 12th St., by putting in \$2,500 of jewelry in the store. The business flourished for several years, Mr. Daskam replenishing the stock of diamonds and watches from time to time as it became diminished.

One day, after Mr. Daskam had returned from a trip to Boston, Mass., he discovered that Sheridan had closed the store and decamped, taking with him the majority of the stock. Subsequently Mr. Daskam recovered about \$500 worth by a suit of replevin.

On April 6 of this year, nearly twenty-seven years after these proceedings, Mr. Daskam, while seated in his office at South Norwalk, was approached by a prosperous looking man and asked if he remembered Peter Sheridan. On his replying in the affirmative the stranger went on to say that he was his half brother Joseph Sheridan, and he had come on from California and had learned for the first time of Peter's ingratitude and the circumstances connected with his business venture. He said that he understood Mr. Daskam had met with business reverses, concluding by asking if he would take \$2,000 in settlement of the claim. Mr. Daskam unhesitatingly replied that he would.

According to an arrangement Mr. Daskam met the stranger at the Astor House last Thursday, and on signing a paper releasing his claim, was paid \$2,000. Joseph Sheridan returned to California the next day.

Connecticut.

H. G. Chatfield, Waterbury, is now located at Curtis's Art store, 107 Bank St., that city.

Buckingham & Leonard, the new Meriden firm, are awakening quite a stir, by the handsome appearance of their store.

Miss Myra D. Holmes, bookkeeper at the Waterbury Watch Co., Waterbury, and J. B. Ebbs, a prosperous druggist, were married Wednesday.

H. B. Hoyt, Norwalk, receives well merited praise for the handsome new badges for the East Norwalk fire police, which he has just supplied.

W. F. Paddock, Bridgeport, is making a special sale of diamonds and diamond jewelry. He is also increasing his stock of watches, silverware and optical goods.

The suit of David Mayer, Hartford, against G. R. Moore, Holyoke, Mass., for \$2,500 on a promissory note, will be called in a few days, before the Supreme Court, in Springfield, Mass.

W. C. Howard, treasurer of the Middletown Plate Co., Middletown, was united in marriage, Wednesday, in the beautiful old town of Farmington, Conn., to Miss Grace A. Perry. The wedding gifts were elegant. A number of influential people of Hartford and Middletown were present, including representatives of the Middletown Plate Co.

E. Ingraham, of the E. Ingraham Co., Bristol, has purchased 150 acres of pineapple land opposite, Melbourne, Fla.

A. W. Pierce, superintendent of the Winsted Optical Co.'s factory, Winsted, will soon erect a handsome new residence.

The Chatfield Jewelry Co., Waterbury, composed of A. I. and G. S. Chatfield is advertising a full stock of aluminum watches.

Columbus.

T. A. Simons has succeeded Simons Bros.

J. G. Schwarzkopf, a salesman traveling for an Eastern jewelry firm, and stopping at

W. G. Nonnemacher, for the past twenty years connected with Harrington & Co., has embarked in business for himself at 249 S. 4th St.

Shortly after 3 o'clock on Wednesday morning, the store of J. & I. Kleeman, 177 S. High St., was broken into and robbed of goods valued at \$150. The plate glass window was smashed by the thieves.

Joseph Barry and Ed. Wilson were taken to the city prison Saturday night, and the entry "suspicion" was placed after their names. The men were found selling jewelry on the streets. It is believed that these are the two men who committed a burglary at the corner of Grant Ave. and Oak St. Thursday night.

the Neil House, had a valuable diamond ring stolen from him on Saturday, but it was soon recovered by a detective. The jewel is valued at \$125.

The Attleboros.

C. W. Fisher returned from California, Saturday.

William Packard has left the employ of F. M. Whiting & Co.

G. E. Curtiss, lately clerk at the Post Office, will on the first of May enter the employ of Riley, French & Heffron as salesman.

B. A. Sibley, bookkeeper for W. & S. Blackinton, left Saturday for a two weeks, trip to Philadelphia, Washington and Baltimore.

The employes of O. M. Draper & Co. worked five days of eight hours each last week. This is the best week since February.

O. M. Draper and wife, and T. I. Smith and wife returned Wednesday from Florida.

Leo Hilboun, of Sandland, Capron & Co., left Friday on a trip through New York State.

T. McGowan, lately employed with Coding Brothers, died last Saturday of consumption. Among the floral tributes at the funeral was a large cross and anchor from the employers and employes.

ESTABLISHED 1841.

CARTER, SLOAN & CO.

MANUFACTURERS OF

FINE JEWELRY,**15 MAIDEN LANE,****NEW YORK.**

A. CARTER, JR.
A. K. SLOAN.
C. E. HASTINGS.
GEO. R. HOWE.
WM. T. CARTER.

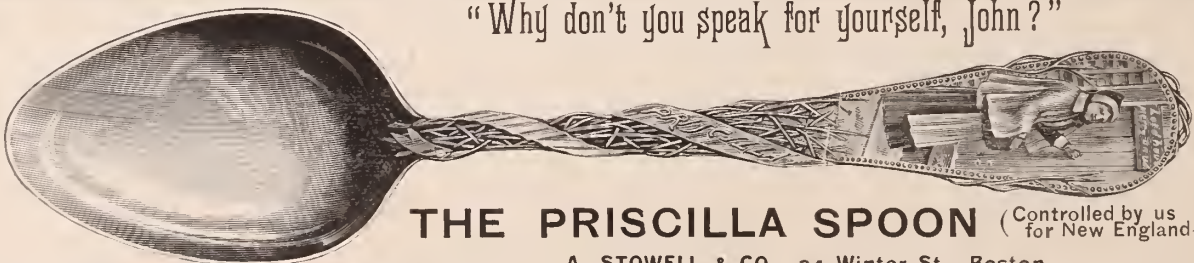

Factory, NEWARK, N. J.

"Why don't you speak for yourself, John?"**THE PRISCILLA SPOON** (Controlled by us for New England.)

A. STOWELL & CO., 24 Winter St., Boston.

"WITCH SPOON" discounts to the Trade. Retail prices as follows: Coffee Spoons, \$1.25, Tea Spoons, \$2.00, Orange Spoons, \$2.25. 25 cents added charge for Gilded Bowls. We believe this spoon conveys the purest sentiment for Engagement Souvenir or Leap Year Purposes. It is difficult to imagine a Souvenir Spoon better adapted to the general demand than the "Priscilla."

As an engagement or sentimental remembrance, embodying as it does, Puritan simplicity and maiden sweetness, it has no equal, and we predict a large demand for it as a LEAP YEAR SPOON, for how delicately would a "laggard in love" be stimulated by the gift of a fair counterfeit of her who so naively said, "Why don't you speak for yourself, John?"

CONTROLLED FOR NEW ENGLAND BY

A. STOWELL & CO., BOSTON.

The Latest, Simplest and Best.

Patent Screw Bezel Case.

CROWN B, No. 2

AND

LION GOLD FILLED.

VICTORY ROLLED PLATE.



two lugs extending beyond the periphery of the band and fitting into two slots prepared for their reception in the centre of the case.

These lugs have a thread cut on their outer edge which meets and corresponds with a thread on the case centre, and when thus combined, the thread on the lugs and that on the centre form a continuous thread, so that when the bezel is screwed on the centre it engages the dustband along with the centre, and thus practically makes the bezel, the band and the centre one piece. In this way all shaking of the band is prevented and it is thus held securely in its place.

The disengaging of the band is accomplished by unscrewing the bezel and simply raising the band by means of one of the lugs attached thereto.

The points of excellence which we claim for our case, are :

(1.) Simplicity and Novelty of Construction. There is nothing complicated about it. The band can be engaged or disengaged with ease by any one.

It is entirely new, being unlike anything put on the market in the way of a Screw Bezel Case.

(2.) Compactness and beauty of shape.

There is nothing clumsy or cumbrous about our Case, and with respect to the second point of excellence, it is without a rival.

In presenting to the trade our New Patent Screw Bezel Case, we desire to call attention to the following characteristic feature in its construction, viz :

THE DUST OR MOVEMENT BAND,

which is independent of the case, and is made with

- A. Lugs on movement ring engaging centre.
- B. Notches in centre to receive movement ring lugs.
- C. Screw in Bezel engaging centre and movement ring.

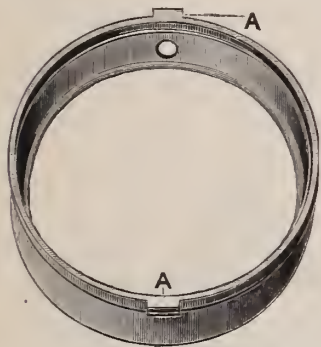

PATENTED NOVEMBER, 1890.

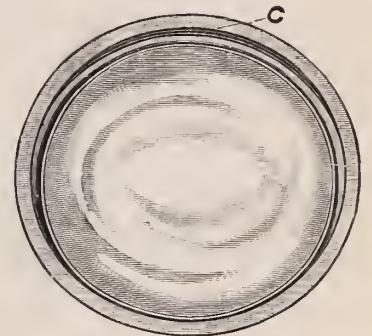

◎◎
**A NEW
Departure.**



◎◎
LION GRADE,
10-KARAT.
ALSO MADE IN
CROWN B, No. 2,
14-KARAT.



H. MUHR'S SONS,

New York : 20 JOHN STREET.

Philadelphia : 629 & 631 CHESTNUT STREET.

Chicago : 141 STATE STREET.

TRADE GOSSIP

C. H. Peckham, 63 Nassau St., New York, takes pleasure in sending diamonds and diamond jewelry on memorandum to reputable houses. Mr. Peckham left last week on a short trip through Connecticut.

A combination of patriotism and an opportunity to get a good bargain, is announced in a half page advertisement in this issue of the Manson Jewelry Mfg. Co., 175 Dearborn St., Chicago, Ill. The retailers of the country will no doubt crowd one another in their earnest endeavor to occupy "front seats" for these offers.

Charles Jacques & Co., 2 Maiden Lane New York, are showing some handsome designs in Mexican onyx clocks. Among them are many original patterns that have never before been placed on the market. Several of the designs are copies of Moorish architecture, and with their artistic side-pieces form very pretty sets.

Many of the customers of the Kent & Stanley Co., Providence, R. I., when in New

York buying their stocks, prefer to place orders for seamless chains with that company. To meet this demand, Kent & Stanley established a sample office, 17 Maiden Lane, New York, which has proven of much convenience to the out-of-town trade.

The sporting season will open in a few weeks, and jewelers will enjoy the usual spring demand for horse timers. Cross & Beguelin, 21 Maiden Lane, New York, are selling a timer that has met with much success. The "Centennial" is a stem winder, starter and setter, all these qualities being confined to the crown of the watch. It has a nickel case and sells at a low price.

The Chicago College of Horology, in its new location, corner of Madison and Robey Sts., Chicago, Ill., is now in a position to offer students great facilities for becoming proficient watch-makers. A material reduction has been made in tuition fees, made possible through lessened expenses. Separate courses in engraving with competent instructors, also frequent lectures by experienced professors on optics make this institution about as near a high grade place of learning as can be found in the country.

The views of Bipart & Co.'s factory, Newark, N. J., which have been published in THE CIRCULAR for the past few weeks, have been a revelation to the trade. The plates,

which are reproductions from photographs, show nearly eighty men at work in long, airy rooms filled with improved machinery and surrounded by all the requisites needed for a first class jewelry manufactory. Bipart & Co. have received many complimentary notices from jewelers who have been over the workshops and immediately recognized the pictures.

In another column will be found an illustration of an alarm clock that has recently been introduced by the Parker & Whipple Co., Meriden, Conn., and thus far has proven a great success. The alarm movement of the clock is a new construction, and it is claimed is superior to any other, owing to its improved escapement. There is no escape wheel nor any pallets to wear away rapidly as in most alarms. The new clock has cut-steel pinions and a celluloid dial and it is handsome in general appearance. As shown in the illustration, the movement rests above two bells which ring with a clearness and freedom from rattle, that is exactly like an electrical alarm. The alarm runs for three full minutes, but can be arrested at any time by moving a small corrugated pin at the back. Jewelers desiring a salable clock should immediately address the Parker & Whipple Co. for price lists, etc.

"LIBERTY" SOUVENIR SPOON.

THIS unique design represents the old Liberty bell in Independence Hall, Philadelphia, which was rung at the signing of the Declaration of Independence, July 4th, 1776.

IT IS ADAPTED FOR SALE ANYWHERE.

Made in Orange, Tea and Coffee Sizes.

This design is controlled and for sale only by

SIMONS BRO. & CO., 618 Chestnut St., Phila., Pa.

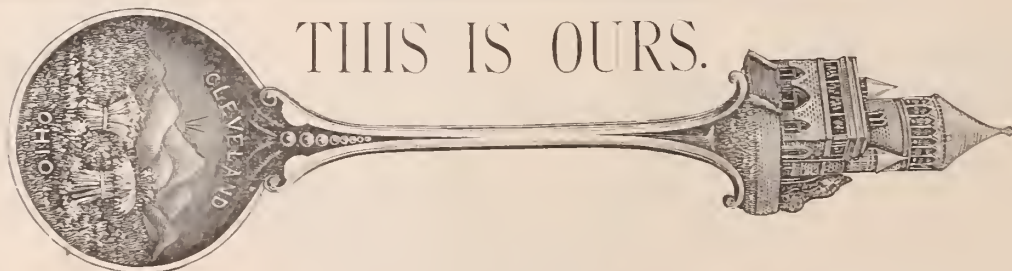
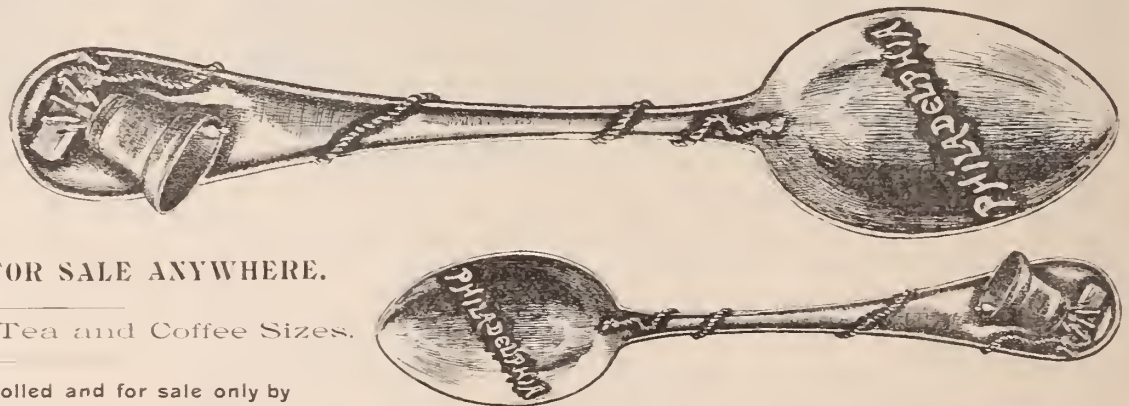

THIS IS OURS.

THE GARFIELD MEMORIAL SPOON.

For particulars, address THE COWELL & HUBBARD CO.,

177 & 179 Superior St., Cleveland, Ohio.

R. A. Breidenbach in his new office at 51 Maiden Lane, New York, has better facilities than heretofore for displaying his large stock of diamonds, precious and imitation stones.

Duhme & Co., Cincinnati O., say that they cannot keep in stock their new corrugated watch case. The demand for them is on the increase. Mr. Laboiteux is working on a subject for an historical souvenir spoon that will be representative of Cincinnati.

Now that the season of white vests is approaching jewelers should remember that W. Rosentall, 79 Nassau St., New York, manufactures a full line of silk chains with gold or silver plated and oxidized slides. The illustration in another column shows one of the many designs produced by Mr. Rosentall.

Gustave Fox & Co., Cincinnati, O., are on the outlook for the parties who are infringing on their patented B. P. O. E. design. On the receipt of an order the other day for a duplicate of a pin that was sent as a copy, they immediately recognized their own design, but made by an Eastern house. The patentees intend to protect their rights.

E. H. Saxton & Co., 58 Winter St., Boston, Mass., and 918 F. St., N. W., Washington, D. C., are calling the attention of the trade to their seamless wire, gold solder vest chains, guaranteed for ten years' wear, and which they sell at only a slight advance over the prices of rolled plated chains. The new chain is named the "Bunyanka" and promises to prove a success.

One of the most convenient diamond weight tables gotten out in recent years is that introduced by H. E. Oppenheimer & Co., 47 Maiden Lane, New York. It consists of a celluloid strip on which is printed the table, with a leather bound slide of the same material. The advantage of the new table is that with the help of the slide one is able to trace the figures across with rapidity and precision.

W. B. Durgin, Concord, N. H., the patentee of the orange spoon, is producing some excellent die work in souvenir spoons. He is now manufacturing the Paul Revere, New Hampshire, Priscilla, and numerous other souvenir spoons, and in consequence of the demand caused by the popularity of these patterns, he has found it necessary to extend his facilities by taking additional shop room.

The Alvin Mfg. Co., 860 Broadway, New York, who have acquired a high reputation for their artistic silver electro-deposit ware have just commenced to make flat ware on quite an extensive scale. Besides the numerous souvenir spoons they have produced, their line contains fancy spoons of odd antique designs, adapted to be souvenir spoons for small towns containing no salient feature. The manufacturers will etch the name of any town in the bowls of these spoons, which are made in tea and orange sizes. Besides spoons, the Alvin Company produce butter dishes, bonbon dishes, trays, etc.

KREMENTZ & Co.,
182 & 184 Broadway, NEW YORK,
MANUFACTURERS OF
GOLD JEWELRY,
14-K. BEAD NECKLACES,
— AND —
KREMENTZ ONE-PIECE COLLAR BUTTONS.

Our line, composed of
*Chain Mountings, Chains, Neck Chains,
Crosses, Bead Necks, Bracelets, Bangles,
Earrings, Glove Buttoners, Garters,
Locketts and Charms, "Mount Hope" Buttons,
Initial Scarf Pins, Bar Pins, Cuff Pins, Jersey Pins,*
is of high grade rolled plate, and as a guarantee that they will wear well we stamp them **F. & B.**

Our sleeve button is the "Mount Hope" and is the best in the world.
FOSTER & BAILEY,
Providence, R. I.

W. ROSENTALL, Manufacturer of **Silk Vest Chains.**
79 NASSAU ST., N. Y.

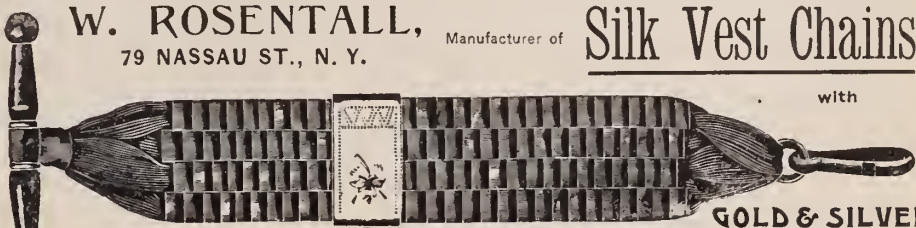

with
GOLD & SILVER

PLATED & OXIDIZED SLIDES.

Send for Selection Package.

SEE THE NEW CUTTINGS
FOR 1891,
CRESCENT
+ + END + +
OLYMPIC



*The best American Cut Glass is that
manufactured by*

THE PHENIX GLASS COMPANY,
OF PITTSBURGH, PA.
Unequaled in its BRILLIANCY, DEEP CUTTING and DESIGN.
729 Broadway, Cor. Waverly Place, N. Y.
43 SIXTH AVENUE, PITTSBURGH, PA

FASHIONS in JEWELRY

A Lady's Ramble Among the Jewelers.

Locketts and crosses are revivals that have evidently come to stay.

Moonstone jewelry is out in new patterns for the summer season.

Some coffee pots in bright finish are decorated with chased bands.

New individual butter plates have gilt centres and nicely chased borders.

Plain, colored and Etruscan gold birds continue to please the feminine fancy.

There are silver coffee pots with side handles for those who like this style.

For those who admire massive jewelry, we commend the large curb-chain bracelets in gold.

Heart-shaped jewel boxes of opaque white glass, with silver rims and satin linings are quite new.

Neck chains from which hang flower pendants, are worn by children, misses and young ladies.

A beautiful salad bowl in bright finished

silver has a chased open-worked border, and is gold lined.

In parasols, straight handles in ivory and shell are to the fore with their gold or silver ornamentation.

Artistic vinaigrettes are richly mounted with chased and ornamented gold, and set with precious stones.

With the present fashion for semi-precious stones of pleasing colors, American stones have come to the fore.

A crystal closet jug with silver handle is hexagonal in shape. Another has an oval instead of a round bowl.

For men's fob chains there are seal and intaglio locketts, also gold and platinum ones set with precious stones.

The new parasol handles show three styles of decoration; the silver deposits, the silver applied and the silver inlaid.

It is no exaggeration to say that well dressed women are now literally wearing rings on all fingers, thumbs, of course, excepted.

Seal rings furnish a great number of styles in varieties of onyx and stones, also entirely of gold, in plain or wrought settings.

Numbered with new pendants for the watch chain are little gold bags, the draw-strings of which are simulated by tiny gold cords.

Old fashioned diamond buckles are again worn on satin shoes, for full dress occasions by ladies who are so fortunate as to possess them.

Very choice are the crystal liquor sets ornamented by the silver deposit process, and exhibited on a silver tray with open work border.

The present style of leather purse is square, or nearly so, of sufficient size to hold one's visiting cards, and trimmed either with gold or silver.

The present season has brought out some of the handsomest and at the same time most curiously shaped water pitchers ever made in silver and glass.

There are opalescent table roses in flower design that stand two or three feet high; others again are in low forms and represent a cluster of open flowers and leaves.

The handsomest earrings seen in some time are hoops of small size formed of two rows of gems, the inner one being of sapphires, while diamonds a size larger form the outer row.

The wheel of fashion revolves and brings round again bygone ideas, in witness whereof are little silver plates for the table on which to set one's glass. Two generations ago tiny china plates did a similar service for tea cups.

Birthday rings set with a stone appropriate to the month in which the anniversary day falls, are by no means confined to children and young ladies. These rings are set in four styles, and therefore afford rings for the middle-aged as well as the youthful.

ELSIE BEE.



RAH! RAH!! RAH!!!

THE RECORD BROKEN.

More Lathes sold in March than in any previous month.

- 1 No. 1 WHITCOMB.
- 30 No. 1½ WHITCOMB.
- 51 No. 1½ WEBSTER-WHITCOMB.
- 1 No. 2 WHITCOMB.

83 IN ALL.

AMERICAN WATCH TOOL CO.,

Stony Batter Works, WALTHAM, MASS.



WEST BURKE, Vt., March 10, 1891.

Dr. C. A. Bucklin:

It has been my fortune to meet with some strange cases, but here is one which, in some respects, eclipse all former experience:

Man, age 51. Bobbin counter in factory.

R. V. = $\frac{9}{20}$ with - 100 C. ax. 100° V. = $\frac{17}{30}$

L. V. = $\frac{10}{30}$ with - 50 = \times 100 C. ax. 175° V. = $\frac{17}{30}$

R. & L. V. = $\frac{10}{70}$ with above combination V = $\frac{17}{30}$

It will be seen that without glasses, the V. in L. surpassed that of R. and L. combined, while with glasses on, both eyes were better than either one alone.

What surprised me most was the fact that so slight an error of refraction should cause so great a disturbance of vision.

Another proof of the genuineness of the case was the fact that a variation of less than 5° in inclination of axis of eyes, should produce very noticeable difference in the vision.

With usual addition for presbyopia, acute and comfortable reading vision was obtained, which had not been the case for many years.

Very truly yours,

H. J. WOODDELL.

If, in your opinion, the above would be of interest to readers of JEWELERS' CIRCULAR, I should be glad to have you use it.

ANSWER: Without glasses in such a case, the visions of left eye should be better than the right. *All the phenomena described* are likely to occur where the astigmatism is not directly vertical or horizontal, and they are much more likely to occur where the astigmatism in the eyes differ in nature and degree. With *equal acuteness of vision* and a proper correction, the confusion of vision which existed before when both eyes were used disappears, and there is every reason why the patient should behave exactly as has been described in the above letter.

GIRARD, O., March 26, 1891.

Dr. C. A. Bucklin:

I have had a few customers for glasses (Presbyopia) who work in the Furnace and Rolling Mills, work altogether in very intense bright light. To read in day time a + 2.50 gives satisfactory vision but at night their eyes trouble them considerably and it requires a + 3.25 to give the same vision as the + 2.50 gives in daytime. At night when corrected with a stronger glass they read well for a time and then their eyes hurt them. Do you think a glass (of the same number that corrects at day) lightly tinted blue would help the vision at night?

E. H. LOTZE.

ANSWER: The tinted glass could only be of use while the individual was exposed to the intense light; otherwise it would be detrimental. The difficulty is evidently due to retinal anæsthesia, resulting from the long exposure to intense light. I am curious to know if those who have left the furnace work have found any greater difference between night and day glasses than other elderly people require. Slight obscurity of the cornea may result from this continued exposure, which would account for these symptoms. Oblique illumination will quickly settle this question.

OPPENHEIMER BROS. & VEITH, Watches, Diamonds and Jewelry,

2 Tulp Straat,

35 Maiden Lane,

AMSTERDAM.

NEW YORK.

SPECIALTY:

Recognizing the demand for

HAMPDEN MOVEMENTS and DUEBER CASES,

We have made a Specialty of these lines of goods and carry a large stock of same.

HAYDEN W. WHEELER & CO.,

2 MAIDEN LANE, NEW YORK,

Have an unusually large and varied stock of

FANCY STONE RINGS,

CONSISTING OF

MOONSTONE, GARNET, TOPAZ, AMETHYST, PERIDOT,
PEARL, DOUBLET, SARDONYX,

And the various combinations of these Stones.

DIAMONDS, ✦ WATCHES, ✦ JEWELRY.

WATCH * CASE * REPAIRING

WITH MY



IMPROVED MACHINERY and INCREASED FACILITIES,



I am enabled to do your work

BETTER,

QUICKER AND

CHEAPER.

IT IS TO

YOUR ADVANTAGE

TO GIVE ME A TRIAL.

G. F. FEINIER,

Manufacturer of Watch Cases; also Repairing of Every Description.

No. 9 Bond Street, New York.

Key-Wind Cases Altered to Stem-Wind, and made same as New. English Cases Altered to take American Movements.

REFERENCE: ROBBINS & APPLETON, NEW YORK.

ARE YOU DISSOLVING PARTNERSHIP
ARE YOU HAVING DULL TRADE
ARE YOU ABOUT TO RETIRE
ARE YOU OVERSTOCKED
ARE YOU REMOVING

IF YOU ARE, COMMUNICATE WITH

A. J. COMRIE,
AUCTIONEER,

Specialty of Jewelers' Sales.

16 West 125th St., New York.

WATCHMAKING SCHOOL.

Have your Young Men become No. 1 Artisans by sending them to

R. Jaegerman's Watchmaking School.

For particulars, write to

R. JAEGERMAN, Manager,

No. 622 Locust St., ST. LOUIS, MO.

ESTABLISHED 1865

RUSCHMEYER & SENG

MANUFACTURERS OF DIAMOND MOUNTINGS
 LADIES' MEDALS & FIRST-CLASS REPAIR WORK
 A SPECIALTY
 ALL MAIL ORDERS RECEIVE PROMPT ATTENTION

OFFICE & FACTORY 309 N. 3RD ST. LOUIS, MO.

342 WEST NINTH ST. ST. LOUIS, MO.



Geneva Optical Co.,
 MANUFACTURERS OF
**Spectacles, Eye
 Glasses, Lenses
 and Cases.**

23 WASHINGTON ST.,
 CHICAGO.

The Highest Grade
 — OF —
**Electro Silver
 Plated Ware**

Is Stamped with the

 **ROGERS TRADE-MARKS.**

MANUFACTURED BY

The Wm. Rogers Manufacturing Co.,
 P. O. DRAWER 30,
 HARTFORD, - CONN.

UNITED STATES OPTICAL CO.

15 Grand River Ave., Detroit, Mich

Manufacturers and Jobbers of

Spectacles and Eye Glasses.

Special Attention given to Prescription Work, and
 Repairing by Skilled Workmen.

Our facilities for the manufacture of **SPECTACLES**
 and **EYE GLASS CASES** are such that
 we can quote lowest prices.

 WILL FURNISH SAMPLES ON APPLICATION.



DANVERS, MASS., March 25, 1891.

Dr. C. A. Bucklin:

A young man friend of mine, who works on bright leather shoe-making, is troubled some with his eyes. He can see plainly at a short distance, say within two or three feet; then take it from 200 or 300 feet, small things look indistinct to him; off to a distance he can see all right.

What kind of a glass would you advise my trying on him? I tried No. 48 cx, but no better results.

J. W. BABBITT.

Answer: No answer can be given from the facts stated and those stated would not prove true when investigated. If the man is young and moderately myopic he would not complain at the reading distance. He probably has astigmatism.

To Restore the Color of a Nickel Movement.

A CORRESPONDENT in the *Journal Suisse d'Horlogerie* recommends the following method for restoring the pristine beauty of a nickel movement: Take fifty parts rectified spirits of wine, one part sulphuric acid, and one part nitric acid. Dip the pieces for about ten or fifteen seconds into this bath, then rinse them in cold water, and throw into rectified spirits of wine. Dry them with a piece of fine linen or in sawdust. Nickel and the majority of other metals which are liable to tarnish, may be restored to their original color by dipping them in the following bath: Dissolve in half a glass of water, six or seven grains of cyanide of potassium; plunge the pieces into this solution and withdraw them immediately. As the cyanide mixes well with the water, it is sufficient to rinse them at once in the latter to destroy any traces of the cyanide. After this, dip the pieces in spirits of wine, and dry in box-wood dust in order to keep them from rusting.

The balance spring even may be subjected to this operation without any danger. If the pieces to be restored are greasy, they must be cleaned in benzine before being dipped in the cyanide, because it will not touch grease. Cyanide of potassium being a violent poison, great care must be exercised, and the operation should be performed in a well ventilated place. The same bath, preserved in a bottle, may be used for a long time.

To Remove Balance-Spring From Staff.

—The best method of removing the balance-spring and collet from the balance staff without injury, is to take them off with a pair of long-nosed diagonal cutting pliers, having the jaws run out pretty well from the handle, and at their ends no thicker than a pen-knife blade. The jaws are placed under the collet, which is lifted off by bringing them together, aided by a slight wriggle of the handles. But the ordinary cutting pliers with thick jaws are entirely unfit for this purpose. It would be better to pry the collet off with a thin knife-blade, used alternately on different sides, so as to raise it equally and keep it level, to avoid springing it apart and making it loose.

A Complete History of Watch and Clock Making in America.*

BY CHAS. S. CROSSMAN.
Number Fifty-five.

Continued from page 41, April 15.

SETH THOMAS CLOCK CO., AND SETH THOMAS SONS' CLOCK CO.

AARON THOMAS, son of Seth Thomas, succeeded to the presidency of the company after his father's death. The original capital was increased in 1863 to \$150,000. The company finding themselves in need of more room, concluded to sell the machinery in the cotton mill and use the premises as a pendulum movement shop. The building was accordingly re-fitted and has since been used for that purpose. Previous to this, both the cases and movements had been made in what now forms part of the present case-shop.

Seth E. Thomas was the successor of Edward Thomas as secretary and treasurer until 1873, when Seth Thomas, Jr., (eldest son of Seth Thomas) who had been engaged in the mercantile business in Plymouth Hoirow for thirty years, was made secretary, Seth E. Thomas retaining the office of treasurer. Both of these gentlemen have held their respective offices from that time to the present, with Aaron Thomas as President.

The first calendar clock made by the company was in 1860, at which time they manu-

*Copyright 1885, by C. S. Crossman.

factured under the Horton patent. They subsequently used the Mix Patent, but at the present time use their own.

The tower clock business was begun in 1872, the company taking hold of the "Hotchkiss Tower Clock," in which Seth E. Thomas had become interested in New York City. They built the clock for Independence Hall, Philadelphia, in 1876, which was purchased by Henry Seybert and presented by him to the city. It weighs thirteen thousand pounds or one thousand pounds for each of the original States. This clock was in care of William E. Harper for some years, and has a rate of about two seconds per month. At the time of the completion of the clock the company had a grand jollification, which was participated in by many of the employes.

During the Paris Exposition in 1878, Aaron Thomas and Seth E. Thomas, and Noah A. Norton, who had charge of the tower clock manufacture went to Paris to represent the interests of the company, William T. Woodruff who had been elected Vice-President, taking charge of the business while they were absent. The company also made extensive exhibits at the Vienna and Centennial Expositions. On Dec. 31st, 1878, a fire occurred at the works; it originated in a shed and store house on East Main and Elm Sts., which had formerly been used as a cotton storage warehouse, when Seth Thomas had been in that business, the entire building being destroyed. It is supposed that the fire was caused by spontaneous combustion.

ETCHING

of views of public buildings, monuments, names of cities and persons in relief on

SOUVENIR SPOONS

and other articles by an improved process. Good Work. Variety of Designs. Charges lower than factory prices.

**J. A. GOLDSTEIN,
ENGRAVER,**

Central Building, WASHINGTON, D. C.

References: GALT & CO., JACOBS BROS., HARRIS & SHAFER, MOORE & LEDING.

FINE LETTERING ON MEDALS, &c., AT SPECIAL LOW PRICES.

ESTABLISHED 1837.

GEO. O. STREET & SONS,
MAKERS OF

Fine Rings, Locketts, Seals, Sleeve Buttons and Links,

15 John Street, - NEW YORK.

**WOOD & HUGHES,
Sterling Silverware Manufacturers.**

New York Agents for the Derby Silver Co.'s FINE QUADRUPLED PLATED WARE.

No. 16 JOHN STREET, - NEW YORK.
206 Kearney St., San Francisco, Cal.
HASKELL & MUEGGE, Agents.



The most desirable line of 16-size movements on the market.

Magic Repair Clamp,

FOR ALL KINDS OF JEWELRY JOBBING.

PRICE, \$1.25.

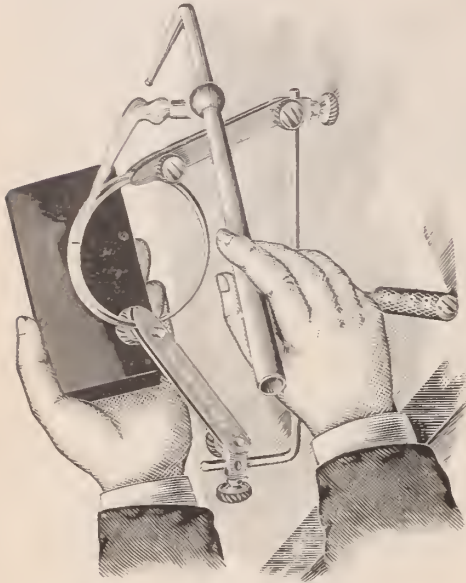

M. MYERS,

7 BROMFIELD ST., BOSTON, MASS.

MAINSPRINGS.



For Sale by all Jobbers.

BOOKS FOR JEWELERS.

W. B. DICKIE,

67 William Street, New York,

PUBLISHER OF

Improved Watch Stock Book

— AND —

Improved Watch Repair Book.

SEND FOR DESCRIPTIVE CIRCULAR.

N. KOCH.

L. DREYFUS.

J. KOCH.

I. PFORZHEIMER.

KOCH & DREYFUS,

22 John Street, New York.

IMPORTERS OF DIAMONDS,

JOBBERS OF

AMERICAN WATCHES,

Diamond Novelties and Jewelry

We have now a complete line of Goods and Specialties on hand and on the road in charge of following representatives :

JONAS KOCH, GEO. MALLET, L. GOLDSMITH,
HENRY HEYMAN, A. ROSENTHAL.

ESTABLISHED 1856.

WILLIAM PARK, Stone Seal Engraver,

Arms, Crests in the highest style of Art. Also Gold Rings, Silver Seals, Brass and Steel Seals engraved SUPERIOR to Stone Seal engraving. Dies cut for Envelope Stamping in best Style.
26 JOHN STREET, N. Y.

HENRY FERA, IMPORTER OF DIAMONDS,

AND DIAMOND BORTZ,
Diamond Cutting and Polishing Establishment,
10 Maiden Lane, NEW YORK.



The Latest "PURITAN" Design.

RICH CUT GLASSWARE.



Headquarters in America for
ART GLASSWARES,
RICH CUT AND DECORATED.
Lamps, Vases and complete lines of everything for
table use or household decoration.

OUR LATEST CREATION—"CROWN MILANO."

Mt. Washington Glass Co.

NEW BEDFORD, MASS.

CATALOGUES FOR

NEW YORK OFFICE, 46 MURRAY STREET.

INTENDING PURCHASERS.

In 1879 a three-story brick building was put up to replace the one destroyed. This is now used for printing dials, and assembling the parts.

The "Nutmeg," a small nickel clock which became so famous, was first put on the market in October, 1876. The case was designed for the purpose of utilizing the scrap cut from the centre of cases of large size. It was the first nickel clock of that size ever placed before the public and was an immense success. The company commenced making walnut cases for mantel clocks in 1878.

The marine shop is located in the western part of the village about one-third of a mile from the case factory. The first building was the one used by the Seth Thomas Sons & Co., to which three additions have since been made, the last one being 150x35 feet and four stories high. The company made a few Yale time locks, but soon gave up this branch of manufacture.

A few years since they started as a regular branch of their business the manufacture of astronomical clocks. In this particular department they are in constant consultation with Prof. Leonard Waldo, late Manager of the Horological Bureau at Yale Observatory. They use both Graham and Gravity escapements, somewhat modified in form. Some of their regulators have very fine rates.

The company are represented in their New York store by Seth E. Thomas, the treasurer, assisted by C. H. Brahe, as business manager; these gentlemen also act as selling agents for the company's productions of watches as well as clocks. Previous to having their own store their productions were sold by the American Clock Company. The company's foreign business has also grown to be extensive in England and many other countries.

The annual production of this company now reaches about six hundred thousand clocks of every description. The force numbers eight hundred. The steady growth of this business from its small beginning to its present size is another illustration of what perseverance and business tact, coupled with a high standard of workmanship, can do to make the production of good, reliable clocks a successful business venture.

To Silver Glass.—Dissolve 3 grains of ammoniacal nitrate of silver in one ounce distilled water, which solution must be rendered somewhat clouded by sufficient nitrate of silver, and then filtered. Immediately before use, mix one ounce of this solution with 2½ grains of Rochelle salt. The glass to be silvered having been cleaned to its utmost, is set into a suitable vessel, the bottom of which is provided with a few wax cones, thus raising the glass about one inch above the bottom, and the fluid is poured over it. The vessel is placed on the northern side of the house, or in a place with deadened light, and the silver precipitate will be sufficiently thick in two hours. It is taken out, washed, and dried; if the glass with the silver pellicle is to be used as reflector or speculum, the coating must be protected by varnish.

DIAMONDS.

Wm. S. Hedges & Co.,

Importers of Diamonds,

And Manufacturers of DIAMOND JEWELRY.
No. 170 BROADWAY,
S. E. Cor. Maiden Lane, } New York.
27 Holborn Viaduct, London.

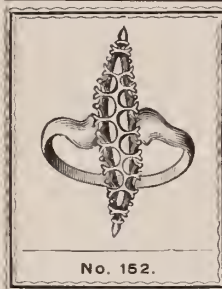

“ S ”

A “NOVELTY” in Marquis Rings.

ASK YOUR JOBBER FOR

STERN BROTHERS' DIAMOND MOUNTINGS,

42 MAIDEN LANE, N. Y.

MAXHEIMER & BERESFORD,

MANUFACTURERS OF

FINE DIAMOND JEWELRY,

No. 3 Maiden Lane, New York.

ORDER WORK A SPECIALTY.

TO THE TRADE ONLY.

Balance Staffs, - 60 Cents.
Inserting Pivots, 40 Cents.
ALL OTHER WORK IN PROPORTION.
SEND FOR PRICE LIST.
THOMAS JUZEK & CO.,
ELGIN, ILL.

REMOVED TO

189 BROADWAY.

R. A. Kipling

Importer of Precious Stones

31, Union Square
New-York

19, Rue Drouot
Paris

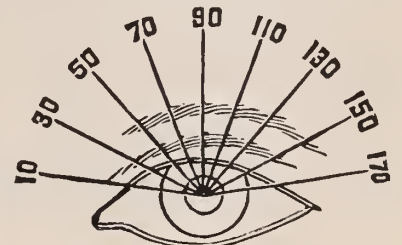

SEND TO

GENEVA OPTICAL CO.

23 Washington St., Chicago.

FOR PRESCRIPTIONS, REPAIR AND ORDER WORK
PROMPTLY AT LOWEST PRICES.

SEXTON BROS. & WASHBURN,

41 MAIDEN LANE, NEW YORK,

MANUFACTURERS OF

FINE JEWELRY,

INCLUDING A FULL LINE OF MOUNTINGS.



PROMPT AND CAREFUL ATTENTION GIVEN TO SPECIAL ORDER WORK.

A. N. CLARK, PLAINVILLE, } MANUFACTURER of the Celebrated
CONN. }

LOOP WATCH KEY.

The best for the price in the World. Size of Square stamped on each Key.

Also Key Rings, Watch Case Springs, Jewelry Tools, Tweezers, Etc.

SEND FOR PRICE LIST. * SOLD BY ALL JOBBERS IN THE LINE AT MANUFACTURER'S PRICES.



BURDON'S SEAMLESS.

THE ORIGINAL
And only Genuine



AND
Perfect Seamless Filled Wires
IN THE WORLD.
Sold to all Manufacturers
alike.

Burdon Seamless Wire.

TRADE-MARK.

The success of the BURDON SEAMLESS FILLED WIRE, like that of all important inventions, has been followed by deceptive and imperfect imitations. For the protection of

ALL JOBBERS AND RETAILERS,

we authorize manufacturers who so desire, to affix upon the tag, card or label accompanying the articles made from this wire, this registered trade-mark owned by this Company.

The bird-on-wire is a guarantee that the goods are made from the original Burdon Seamless Filled Wire, the reputation of which has been firmly established among the best dealers for more than two years. The perfection and qualities of the Burdon Seamless Wires are always guaranteed. All Dealers (jobbers and retailers alike) should, therefore, demand goods made from the original Burdon Wire, and avoid imitations which are offered as "just as good."

BURDON SEAMLESS FILLED WIRE CO.,
109 to 119 and 127 Summer Street,
PROVIDENCE, R. I.

TELL A. BEGUELIN,

IMPORTER OF
WATCHES,

Watch Materials, Tools and Glasses,
No. 71 NASSAU STREET,
(UP STAIRS.) NEW YORK.
Cor. John Street,

Sole Importer of Material for the
"Bijou," "Victor," "Boston," "Bristol,"
"Adelphia," "Jockey Club," "Wallingford,"
"Casar," "Lady Racine" and "New Haven"
Watches

Selling Agent for materials for LONGINES
and AGASSIZ Watches.

AMERICAN WATCHES,
ALSO STEM WIND WHEELS
Importer of Full Line of Swiss Watches,
AND FRENCH CLOCK GLASSES.

S. COTTLE & CO.,
MAKERS OF
FINE JEWELRY AND SILVER
NOVELTIES,
No. 86o Broadway, NEW YORK.

R. & L. FRIEDLANDER,

Wholesale Jewelers,

AND

JOBBER'S IN AMERICAN WATCHES,

Tools, Materials and Optical Goods,

65 & 67 NASSAU STREET, N. Y.

Factory, 50 BOND STREET.

Send Business Card and we will mail you our Watch and Jewelry Catalogue, No. 12, and our Tool, Material and Optical Catalogue, No. 14.

READ THIS LETTER:

HENRY ERBSMEHL,

Watchmaker & Jeweler,

Watches, Clocks, Jewelry and Silverware.

MILFORD, DEL., March 4th, 1891.

MESSRS. R. & L. FRIEDLANDER, New York City.

GENTLEMEN: It gives me pleasure to recommend to the trade your Monarch Main Springs, for American Watches. They are, without exception, the best Main Springs that I have ever used. I have tried all makes within the last 25 years, but have found none equal to the Monarch Springs. They are uniform in force and temper; out of 6 dozen springs, I have lost but two.

I remain, yours truly,

HENRY ERBSMEHL.

Try our Monarch American Main Springs, \$12.00 PER GROSS,
\$1.00 PER DOZEN
POSITIVELY NO GOODS SOLD AT RETAIL.

Established 1872.

PLAINVILLE STOCK CO.

P. S. CO.

THIS TRADE-MARK REGISTERED, AND STAMPED ON ALL OUR GOODS.

BROOCHES, SCARF PINS, DROPS, SETS.

FACTORY AT PLAINVILLE, MASS.

SAMPLES AT 176 BROADWAY, NEW YORK

DIAMOND SETTINGS.

GALLERIES.

HOLLOW BALLS, ETC.

BLANCARD & CO.,

36 & 38 JOHN STREET,

SEND FOR OUR

NEW YORK.

CATALOGUE.

MUSICAL JACOT & SON,
298 Broadway,
New York

Send for Catalogue.

Musical Boxes Repaired.

BOXES

GILBERT T. WOGLOM,

BLACK ONYX

MAKER OF
Pearl Ornamented
and Plain
JEWELRY.
GOLD MOUNTED.

32 & 34 John St. New York City.

Designers see page 8
of the new Crescent catalogue.

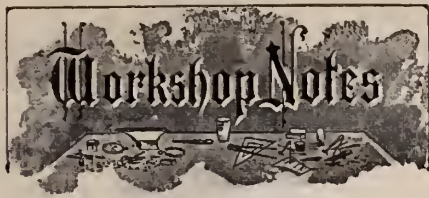

Scarce Brass Alloys.—Bristol brass (Prince metal), six parts copper, two zinc; Japanese brass (Sinchu), ten parts copper five zinc; white brass, one part copper, eight zinc, one iron—very suitable for statue casts in place of bronze.

Rust.—Nuts are oftentimes so tightly rusted upon screws that other means than unscrewing must be made use of to loosen them; kerosene or naphtha, even turpentine, will, in a short time, penetrate between the nut and stern. Next, heat them in the fire, which will quickly loosen them.

Bronzing Medals.—According to the *Revue Ind.*, medals are bronzed in the Paris mint by boiling them in a copper kettle, not tinned, in a solution of 500 grains of pulverized verdigris, and 475 grains of pulverized sal-ammoniac, 160 grains of strong vinegar and 2 liters of water. The medals are kept apart by wood or glass rods.

To Polish Steel—If the steel is of moderately good temper, use a zinc polisher with diamantine; a tin-polisher is better for soft steel. The diamantine should be mixed on glass, using a heater also of glass, with very little watch oil. Diamantine mixed with oil becomes gummy, and quite unfit in a day or two, it also turns black, if brought into contact with metal, when mixing.

Cleaning-rags.—These cleaning-rags, which are excellent for polishing metallic surfaces, are prepared in the following manner: Dip flannel rags into a solution of 20 parts dextrine and 30 parts oxalic acid in 20 parts logwood decoction; wring them gently and sift over them a mixture of finely pulverized tripoli and pumice stone. The moist rags are piled one upon the other, placing a layer of the powder between each two. They are then pressed, taken apart and dried.

To Bleach Yellow Ivory.—Ivory that has become yellow may be easily bleached in the following manner: The article is placed under a glass bell, together with a small quantity of chloride of lime and hydrochloric acid, whereby chlorine is developed, and exposed to sunlight. Be very careful not to breathe the vapors, as they are very poisonous. The bleaching power of the chlorine destroys the yellow pigment upon the surface, and the article will be restored to its original lustre.

Soldering Fluid.—Dissolve sheet zinc in hydrochloric acid until the acid will take up no more zinc. Turn off the clear liquid, and dilute it with alcohol instead of water. When diluted with water it must retain acid enough to rust, but with alcohol the dilution can go on till the acid is no longer perceptible to the tongue.

To Manufacturing Jewelers.

To more fully introduce our improved method of Roman coloring, we will do a piece of work, **FREE OF CHARGE**, for any manufacturing jeweler. This improved process produces a result superior to acid colored work, and has given full satisfaction to the many of our customers now having their work done by us.

Respectfully,

JEANDHEUR BROS.,

BRANCH OF
F. JEANDHEUR, JR.,
4-6 LIBERTY PLACE, N. Y.

93 Green St., Newark, N. J.



Fleur de Lis "VICTORIAS."

WE ARE SHOWING THE

Most Popular Line

IN THE MARKET.

H. F. BARROWS & Co.,

1½A Maiden Lane, N. Y.

S. C. JACKSON, 180 BROADWAY, NEW YORK,
MANUFACTURER OF

Fine Cases for Jewelry, Silverware, Etc.,

ALSO SHOW CASE TRAYS AND FANCY HARD WOOD WORK.

Samples sent on application. Estimates furnished.

BUY THE "BARON" SPECTACLE.



The best Periscope Spectacle in the World for Opticians to sell for \$1.00. Sole manufacturers, LEVY, DREYFUS & CO., 11 Maiden Lane, New York.



Patented Jan. 17 h, 1888.

C. G. HARSTROM,
PEEKSKILL, N. Y.

Will send sample of this all steel adjustable Case Spring, a 14-size, Swiss or American, for ten cents. Stamps.

SEND FOR CATALOGUE B.

LARGEST MANUFACTURER OF BADGES AND MEDALS.

SEND FOR CATALOGUE.

C. G. BRAXTON, JEWELER, 47 CORTLANDT ST. NEW YORK.

BADGES

The following speak for themselves:

MR. NYE, WINONA, MINN., Nov. 15, 1890.
DEAR SIR: It affords me great pleasure to send you this voluntary recommendation of your justly celebrated watch oil. It is being used and appreciated by the graduates of W. F. A. Woodcock's Watchmakers' School, from the Atlantic to the Pacific, and I recommend it in the highest terms to all good watchmakers.
I am, yours respectfully,
W. F. A. WOODCOCK.

COLUMBUS, NEB., Feb. 15, 1891.
WM. F. NYE, New Bedford, Mass.
DEAR SIR: Your kind favor to hand.
Thanks for prompt reply. Referring to the test of your Watch Oil by D. L. Brown. I have tried all kinds of oil for watches, and am free to state that I could not be induced to use any other than your brand, as it's the only oil one can rely on in cold climates. I often have watches carried by my customers three years without cleaning or re-oiling.
Yours truly,
A. J. ARNOLD

WILLIAM F. NYE,
MANUFACTURER OF
The finest Watch and Clock Oil made,
NEW BEDFORD, MASS.

THE "MOLL PITCHER" SPOON.

(REGISTERED TRADE MARK.)

Moll Pitcher, of whom the poet Whittier wrote, was a noted Fortune Teller of Lynn, many years ago.



MOLL PITCHER.



We are receiving orders from the Trade all over the country, and our sales are constantly increasing. Dealers who order once, soon order *more*.

PRICES.

Coffee Spoons, - - - - -	\$1.25	Orange Spoons, - - - - -	\$2.25
(gold bowl), - - - - -	1.50	(gold bowl), - - - - -	2.50
Tea Spoons, - - - - -	2.00	Trade discount—15 per cent. 30 days, 3 per	
(gold bowl), - - - - -	2.25	cent. extra, 10 days.	

Send for a sample line (one spoon each style). We are *confident* they will meet with ready sale.

W. F. NEWHALL, Jeweler,

52 MARKET STREET,

LYNN, MASS.

Jules Jürgensen

OF COPENHAGEN.

The reputation these watches have maintained for Fifty Years has never been equalled, being made on strictly scientific principles, and no expense spared to give the Best results in mechanism and timekeeping qualities.

SOLE AGENTS.

John C. Hyde's Sons,
No. 22 MAIDEN LANE.

BOSTON HEADQUARTERS FOR ILLINOIS, HAMPDEN

And all other American made Movements. Also full line Jewelry and Diamonds, etc.

E. F. WILSON & CO, 409 WASHINGTON ST., BOSTON, MASS.

YOU ARE COMING TO THE WORLD'S FAIR,

And we want to pay your fare both ways, and all we ask is that you buy direct from us one dollar for every mile that you live from Chicago, and you have about two years in which to send us your orders.

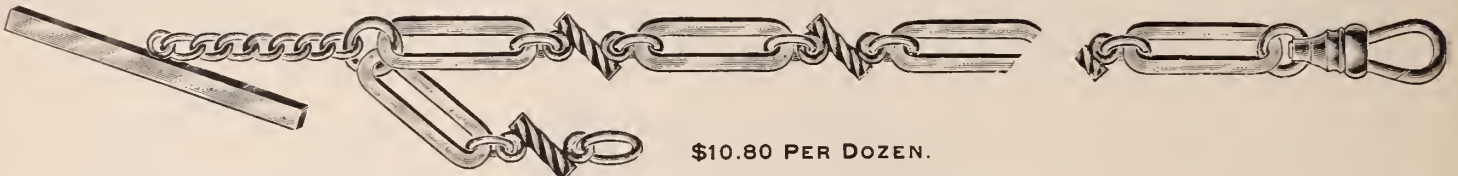

\$10.80 PER DOZEN.

We are having a great demand for our \$10.80 per dozen chains, which we are selling direct to the retail trade. This chain is warranted for five years, and we agree to replace every one that does not prove exactly as represented. Every swivel is stamped with our name and tag as shown in cut. No jeweler who has used our goods will do without them. In addition to these five (5) year chains we make a large line of 10-year filled and seamless, also novelties in ladies' jewelry.

We are also making 10 Karat fancy engraved BAND RINGS as shown in the cut, below, which have proven a great favorite with the trade.



We are selling these Rings in dozen lots, assorted sizes, at 65 cents per dwt. net, the average being less than \$1.00 each. In buying them by weight you are paying no fancy dozen price, but are getting what you pay for. We will have our CATALOGUE ready for the trade soon. In the meantime we will send a selection package of our goods to any responsible dealer in any part of the United States.

MANSON JEWELRY MANUFACTURING CO.,

Manufacturers of FINE ROLLED PLATE CHAINS, CHARMS, LOCKETS, JEWELRY, NOVELTIES, Etc.

175 DEARBORN ST., CHICAGO, ILL.

FACTORY: ATTLEBORO, MASS.

27 N. B.—All business with the retail trade transacted through the Chicago office.

Town Talk.

H. S. Greenwood, a commercial traveler, recently brought suit in a New York District Court against his employers for money claimed to be due him. The case was decided against the plaintiff on the ground that some of the items in a statement of expenses on which he based his suit were improper. These items were aired in court and some of them were decidedly ludicrous, such as for shampoos, rubbers, hair cut, shaves, umbrella, theatre tickets and for pressing of clothing. When all these had been stricken out he was in his employers' debt.

While a CIRCULAR reporter was talking to a Maiden Lane optician recently, there came in the store a son of the Emerald Isle, apparently as green as his native plant. Gazing around in a timid manner he said he wanted a pair of spectacles to enable him to read. After the clerk had spent over an hour in showing different glasses and making the usual tests, he became somewhat weary, and in an earnest voice asked:

"Can you read, Sir?"

"Shure," came the astonishing reply, "if I could rade, d' yer think it's meself would be afther buying a pair of specs."

"Hall-marking is a voluntary institution

in Belgium, Denmark, Germany and Italy," said a manufacturing jeweler, recently. "In Austria," he continued, "Hungary, France, Sweden and Norway; it is voluntary for exports. In Spain imports and exports are free. In Russia half the hall-marking fees are returned when the goods are intended for exportation. The only countries in which hall-marking is obligatory, alike for home use and exportation, are England, Holland, Portugal, Russia and Switzerland."

Very few Maiden Lane jewelers are aware that it was owing to the strenuous effort of H. B. Sherrill, of Sinnock & Sherrill, that they enjoy the convenience of having a letter box outside the Palmly Building. About a year ago the box was on Broadway, at the corner of Maiden Lane, and Mr. Sherrill recognizing the necessity of having it situated further down the street, petitioned the Postmaster to that effect. His communication resulted in the removal of the box to its present location.

G. C. White, of Rogers & Bro., New York, who was a member of the Appraisal Committee of the old Board of Directors of the Brooklyn Union Ferry Co., which valued their assets at about \$1,400,000, is not a member of the present Board, which values the same assets at \$3,200,000. Mr. White, by the way, is a prominent citizen of the City of Churches, and is interested in several enterprises of that town.

THE UNITED STATES WATCH CO., WALTHAM, MASS.

Carry in stock a full line of their celebrated 6 size Ladies' watch, in nickel and gilt, 7, 11, 15 and 16 jewels, from plain to fully adjusted.

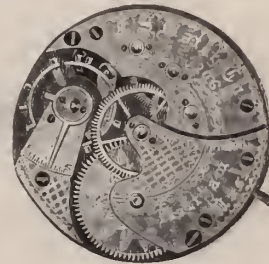

Also a complete line of 18-size Hunting and 16-size Open Face all grades, in nickel and gilt. The reputation of the United States Watches is too thoroughly established to require statement here—they excel in finish and time-keeping qualities those of any other make. Our factory at Waltham, Mass., is the model in automatic machinery and tool equipment. When you want a timepiece call for the United States Watch. On sale by all non-association jobbers, to whom retailers should apply for a complete line of these watches as they give less trouble and more satisfaction than any other. Address all communications to the UNITED STATES WATCH CO., Waltham, Mass.

N. Y. Office, 53 Maiden Lane, F. S. Baker, Agt.

A GREAT CONVENIENCE FOR

✻ Clock Dealers and Repairers. ✻

We have now a complete stock of Wheels, Pinions, Hands, Dials and all loose pieces for French and English movements. Also single movements with or without dials.

Our stock of imported clocks comprises Chiming and Hall Clocks, Sèvres and Faience, Vernis Martin, Gilt Bronze, Crystal with Mercurial Pendulum, Carriage Clocks in endless variety of styles and combinations, Marble and Onyx Clocks of the best selling designs, Coaching and Desk Watches, Regulators, etc.

NEW GOODS ARRIVING EVERY WEEK.

Apply for our Catalogue, or inspect our stock to compare our prices.

CHARLES JACQUES & CO.,

2 MAIDEN LANE, NEW YORK.

Ludwig Assen
D. W. Moore
Alex. B. Chard

18 JOHN ST. NEW YORK

MOORE & HORTON,
MANUFACTURERS OF
SOLID GOLD JEWELRY,
No. 11 Maiden Lane, New York.
Fine Imitation Diamond Goods a Specialty.
Selection Packages sent on Application.

The New Trenton



18 SIZE, SEVEN JEWELS, NICKEL.
HUNTING AND OPEN FACE S. W.

Quick train, straight line lever escapement, safety centre pinion, enamel dial, beautifully damaskeened and exceedingly attractive in appearance.

THE BEST LOW PRICED WATCH EVER PRODUCED.

For Sale by the Jobbing Trade.

TRENTON WATCH CO.

TRENTON, N. J.

ALEX. WIEDERHOLD,
20 MAIDEN LANE, N. Y.,
REPAIRING JEWELER.

Jobbing sent to me by mail or express will be repaired and returned promptly. Prices Moderate and First-class Workmanship Guaranteed.

Recent Patents

Issue of April 14, 1891.

DESIGN PATENT 20,672. HANDLE FOR SPOONS, ETC. ALBERT N. WOOD and FREDERICK M. WOOD, Boston, Mass.—Application filed March 7, 1891. Serial No. 384,161. Term of patent 3½ years.

DESIGN PATENTS 20,673 and 20,674. HANDLE FOR SPOONS, ETC. WILLIAM B. DURGIN, Concord, N. H.—Applications filed March 20, 1891. Serial Nos. 385,821 and 385,822. Term of patents 7 years.

DESIGN PATENT 20,675. HANDLE FOR SPOONS, ETC. REUBEN HARRIS, Washington, D. C.—Application filed March 14, 1891. Serial No. 385,135. Term of patent 7 years.

450,177. RIMLESS SPECTACLES OR EYE-GLASSES. JACOB G. MISSIMER, Philadelphia, Pa., assignor to James W. Queen & Co., same place.—Filed Sept. 5, 1890. Serial No. 364,208. (No model.)

These spectacles consist of the lenses ground upon opposite faces and forming depressions, the outer straps having portions embracing the sides and rims of the lenses and cemented thereto, and the nose-piece formed with integral portions, embracing the sides and rims of the lenses, and cemented to both the sides and rims.

450,263. WATCH-MAKERS' STAKING-TOOL. GEORGE SYLVIA, Waltham, Mass.—Filed Oct. 3, 1890. Serial No. 366,939. (No model.)

Claim.—In a staking-tool, the base-block and the movable locking-bolt, combined with a revoluble perforated plate, mounted on the base-block and provided with holes, to receive the locking-bolt.

450,273. BUTTON. FRANK E. WILLIAMS, New York, N. Y., assignor of one-half to Horton, Angell & Co., Attleboro, Mass.—Filed July 23, 1890. Serial No. 359,593. (No model.)

A button or stud consisting of a head with a curved arm or post, and a bent arm mounted to slide on the

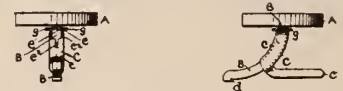

curved arm or post, and having a flange above its lower open end, this flange being adapted to operate the bent arm.

450,293. TIME-LOCK. PHINEAS F. KING, Cincinnati, Ohio—assignor to the Mosler Bank Safe Company, same place.—Filed Oct. 29, 1890. Serial No. 369,725. (No model.)

450,390. ELECTRIC TIME-CALL. RICHARD VARLEY, JR., Englewood, N. J.—Filed Nov. 18, 1890. Serial No. 371,810. (No model.)

450,409. OPERA-GLASSES. JAMES GREEN, Burwood, near Sydney, New South Wales.—Filed May 13, 1890. Serial No. 351,702. (No model.)

The combination, with an opera-glass or similar telescope, of a pair of reflectors supported upon a carrier arranged in front of the object-glasses of the telescope, and a shutter or blank in front of the reflectors, the reflectors and shutter being removably connected with the telescope.

450,412. JEWELERS' STOCK. GEORGE E. A. KNIGHT, Providence, R. I.—Filed Sept. 22, 1890. Serial No. 365,782. (No model.)

Jewelers' stock consisting of a sheet formed of a number of strips of precious metal varying in color, both surfaces of which are striped, folded, and condensed to form a bar, rod or wire of precious metal.

450,427. MEANS FOR RECOVERING LOST OR STOLEN WATCHES. JOHN W. SCHELL, Philadelphia, Pa.—Filed Sept. 6, 1889. Serial No. 323,137. (No model.)



THE PRINCESS LAMP.

The handsomest decorative Lamp ever produced. Made in largest variety, and richest designs by

GEORGE EAKINS & SON,

616 Chestnut St., Phila., Pa.

Made expressly for fine Jewelry Trade.

SEND FOR DESCRIPTIVE PAMPHLET AND PRICES.

KENDRICK & DAVIS,

LEBANON, N. H.

MANUFACTURERS OF THE

Standard Dust Proof Watch Key.



After this date all Keys of this Style will have number stamped on each Key.

FOR SALE BY THE TRADE.

A means for recovering lost or stolen watches, consisting of a general register provided with a series of columns with printed headings designating watch registered numbers, case and works numbers, location, and description of owner, and indices for the register

No.	Name	Residence	Pat. No.	Serial No.	Location	Description	Owner
1							
2							
3							
4							
5							
6							
7							
8							
9							
10							
11							
12							
13							
14							
15							
16							
17							
18							
19							
20							
21							
22							
23							
24							
25							
26							
27							
28							
29							
30							

No.	Name	Residence	Pat. No.	Serial No.	Location	Description	Owner
1							
2							
3							
4							
5							
6							
7							
8							
9							
10							
11							
12							
13							
14							
15							
16							
17							
18							
19							
20							
21							
22							
23							
24							
25							
26							
27							
28							
29							
30							

embodying a series of columns with printed headings designating watch registered numbers and case and works numbers.

450,474. JEWELERS' CLAMP. ERASTUS N. PARKER, Springfield, Mass. Filed Dec. 15, 1890. Serial No. 374,662. (No model.)

The tool for jewelers' use comprising in combination, a base consisting of a round rod, a plurality of clamping-arms mounted upon the rod and adjustable

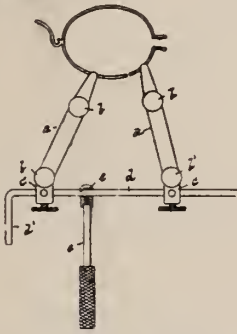

both longitudinally thereof and about the same as a centre, each of the clamping-arms being composed of two strips or bars and having means, as a thumb-screw, for drawing the outer ends thereof together and a suitable handle or support for the base.

450,520. WATCH-MAKER'S PUNCH. URIAH D. MINER, Starke, Fla. Filed Dec. 13, 1890. Serial No. 374,603. (No model.)

In a watch-maker's punch, the combination of the lower jaw formed with the openings 12 and 13, the

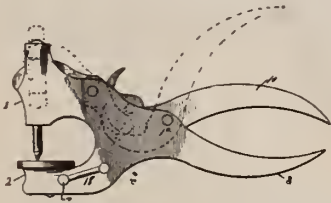

slotted upper jaw and the punch having the slotted upper end and the pivoted levers for operating the same, the apertured disk 15, mounted on the pivot-stem 14, and the clamp 17, having the adjusting-handle 18.

450,528. CLOCK-CASE. HENRY S. PRENTISS, New York, N. Y. Filed Aug. 3, 1889. Serial No. 319,651. (No model.)

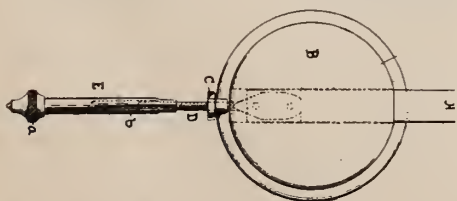

450524. CAMPAIGN BADGE. HENRY PHILLIPS, New York, N. Y. Filed Dec. 13, 1890. Serial No. 374,606. (No specimens.)

The combination, in a campaign badge, of a hollow body having its front formed with lower openings,

pictures arranged on the back of the body opposite these openings, a slide having humorous pictures upon it adapted to register with the openings when the slide is pulled down, a rubber and a tassel connected to the slide.

450,566. WATCH-CASE SPRING. JAMES H. FLEMING, Newark, N. J. Filed Dec. 30, 1890. Serial No. 376,199. (No model.)

The one-piece backing or support for a watch-case fly or lock spring, consisting of a curved piece of metal adapted to be inserted in the watch-case center, and at one end doubled on itself, and at the convex side of the backing having an opening or separation, whereby the doubled portions may move from one another when the backing is flexed.

450,579. WATCH-PENDANT. FRANK G. FAXON, Mount Morris, N. Y., assignor to the Keystone Watch Case Company, Philadelphia, Pa. Filed Oct. 27, 1890. Serial No. 369,475. (No model.)

450,529. SUPPLEMENTAL PENDULUM-BOB. HENRY S. PRENTISS, Elizabeth, N. J. Filed Nov. 10, 1890. Serial No. 370,882. (No model.)

FRANKLIN, Ind., April 13, 1891.—I admire THE CIRCULAR in its new form.

CHAS. A. BECK.

IAMANTA
Spectacles and Eye Glasses are the best
M. ZINEMAN & BRO.,
130 South Ninth St., Philadelphia.

IAMANTA

THE RYDER & DEARTH CO.
DESIGNERS & ENGRAVERS
Fine Commercial and Copper-Plate Printers.
A Specialty of
Jewelers' Printing, Cuts and Electrotypes.
Headquarters for JEWELERS' CARDS.
BEST WORK. PROMPT DELIVERY. LOW PRICES.
No Order Too Large! None Too Small!
146 Westminster Street,
PROVIDENCE. - RHODE ISLAND.

HILDRETH MANUFACTURING COMPANY,

53 MAIDEN LANE, NEW YORK.

MANUFACTURERS OF PLAIN SOLID GOLD RINGS.

SEND FOR PRICE LIST.

A. WITTNAUER,
30 Maiden Lane, New York,
MAKER OF
COMPLICATED * WATCHES.

TIMING WATCHES

OF ALL STYLES.



SPLIT SECONDS

AND

Minute Repeaters.

VARIOUS GRADES, ALL ACCURATELY MADE.

Also Sole Agent for the Celebrated LONGINES & AGASSIZ Watches.

The Other Side of Life.

HE WONDERED.

Mr. Ponsonby—Here's an article in which it is said that 2,350,000 watches are turned out by the fifteen factories of the country each year. I wonder where they all go to?

Mrs. Ponsonby—Up the spout. Now go down and bring up the wood.

REAL GLORIOUS.

Miss Russellina Emerson (of Boston)—Oh, dear, mater and I have had such a delightful day!

Miss Olivina Wendell—Do say!

Miss R. Emerson—Yes, we went to our opticians' and they allowed us to look over their entire stock of glasses.

WITH OR WITHOUT DECORATIONS.

Mrs. MAGNUS SCOTT—Now that Lent is over, Magie, I wish you would give me that diamond necklace you promised me.

Mr. MAGNUS SCOTT—Will you have it with or without?

Mrs. MAGNUS SCOTT—With or without what?

Mr. MAGNUS SCOTT—A bill of sale on my business.

ON THE PONS ASINORUM.

HAROLD HARRINGTON—Weawing spectacles, Cholly? wherefore, deah boy?

CHOLLY CHOLMONDELEY—The Pwince has soah eyes.



STRATEGIC.

OPTICIAN (to his clerk who is sending out new price-lists)—Write the addresses of our customers very small, so that the people will have to use glasses to read them.—*Fliegende Blätter.*

THE CLEVER WOMAN.

She had so very much to say
 She really hadn't time to think
 She'd talk throughout the livelong day—
 She had so very much to say.
 She never thought, yet, in a way,
 She'd be almost upon the brink;
 She had so very much to say,
 She really hadn't time to think.

—*New York Evening Sun.*

CORRECTLY USED.

"Ah," said Larry O'Shea, as he gazed in the jeweler's window, "that watch is a pretty good timekeeper, I take it." And he took it.—*Harvard Lampoon.*

A PROOF OF INSANITY.

MAGISTRATE (to prisoner)—You are found guilty of meeting the plaintiff in a lonely street, knocking him down, and robbing him of everything, except a valuable gold watch, which he had with him. What have you to say?

PRISONER—Had he a gold watch with him at the time?

MAGISTRATE—Certainly.

PRISONER—Then I put in a plea of insanity.—*Life.*

"I bought two watches to-day."

"Isn't one enough?"

"No. I want plenty of time; I'm calling on Alice to-night."

AND HE KNEW WHAT SHE MEANT.

JESSIE—Johnnie, why don't you go upstairs; it is past your bed time.

JOHNNIE—I'm waiting for Mr. Younglove's face to stop the clock; you know what you said!—*New York Evening Sun.*

**EZRA KELLEY'S
 Famous Watch, Clock and Chronometer Oils,**

RECEIVED AT THE
 EXHIBITION UNIVERSELLE, PARIS, 1889.

The only Award of Merit given to Manufacturers of American Oils

It is to the interest of every Watchmaker to use in his work the *Best Oil* obtainable, regardless of cost. Mr. Kelley's claim to be the foremost manufacturer of Oils, giving the best results, is not based upon his own assertion, but is founded upon the fact that wherever his Oils have been exhibited in competition with other makes, subject to an examination of experts, they have received the highest *Award of Merit*.
 For sale by all the Leading Jobbing Houses.

HENRY GINNEL & CO.,

GRIMSHAW & BAXTER, EUROPEAN AGENTS,
 35 GOSWELL ROAD, LONDON, ENGLAND.

GENERAL AGENTS,
 31 Maiden Lane, NEW YORK

LOUIS NEWMAN, JR.

GOLD AND SILVER

Plater, Fire Gilder and Colorer.

Gilding by a New Process. Watch Cases, Jewelry and Novelties, Work stands acids, and in finish equal to Gold.
 36 & 38 JOHN STREET, NEW YORK.

WIGGERS & FROELICK,
 60 NASSAU ST., NEW YORK,
 Sample Cases and Trays
 For Watches, Jewelry, Optical Goods, Etc.

WE STRIVE TO MAKE THE BEST

**TO THE TRADE.
 FINE WATCH REPAIRING**

BY
JOHN C. SIMMONDS,

18 JOHN STREET, NEW YORK.
 New pieces, such as Chronometer Locking Springs, Balance Staffs, &c., made in the best styles. Watches sprung and adjusted to temperature and positions.

THE LATEST PARISIAN NOVELTY.



MANUFACTURED BY
CROSSIN & TUCKER,
 409 Pine Street, Providence, R. I.

GENTLEMEN: I thank you for past favors, and further, those hair-pin chains are going all right. We are having a good demand for them. I knew they could not help going, they are so dressy. While I am constantly trying to introduce novelties, the old ones are so good it is hard to get the people to change. Well, I would just as soon sell the old ones, and if you want any Eye-Glass Holders and Chains, shall be pleased to hear from you.

Respectfully,

S. F. MERRITT,
 Springfield, Mass.

Essex Watch Case

COMPANY,

T. B. HAGSTOZ, President.

TRADE MARK

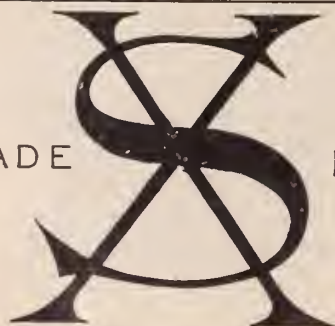

6 Maiden Lane, N. Y.

OFFICE,

NEWARK, N. J.
 FACTORY,

GOLD FILLED CASES.

ESTABLISHED 1873.



If for any reason you should desire the services of an AUCTIONEER, and will write me as to the amount of stock you have on hand and its general character, the size of your store and the number of inhabitants of your town or city, I could, from my extended experience, give you an idea of the amount of business you could expect under the circumstances, and, no doubt, be able to refer you to some one for whom I have sold under conditions similar to your own.

As a general reference, you could hardly find a wholesale jeweler who is not familiar with some of the numerous successful sales I have made.

I have made many successful AUCTION SALES, and have yet to record a failure to fully satisfy the owners. Can give you hundreds of references to that effect.

If the business should be urgent and I am myself engaged, I have two competent assistants instructed in my methods whom I could send on short notice.

Any correspondence with me will be strictly confidential in every case.
P. O. Box 2775.

NEW YORK CITY.

YOUR TOTAL SALES AND EXPENDITURE

By the Day, Week and Month, shown at a glance by the "Complete Business Register," the best arranged book for keeping a record of the condition of one's business. Send for free sample sheet, prices, etc. Address,

H. W. PAMPHILON,
30 Bond Street, New York



A Wonderful TOOL FOR THE BENCH.

Instantaneous in Its Work.

Dividing the inch into one thousand parts. A most practical tool for watchmakers for gauging from a hair-spring to a main-spring. Non-comparable for a height and depth gauge. Instantaneous for hair-spring work.

For sale by all Jobbers.

NORDMAN BROTHERS,
120 Sutter St., SAN FRANCISCO, CAL.
Sole Agents for the United States.

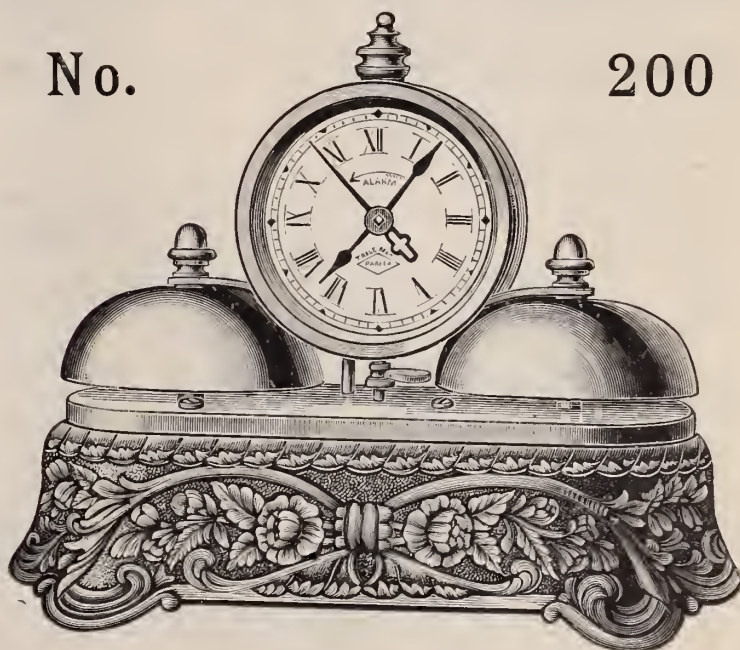
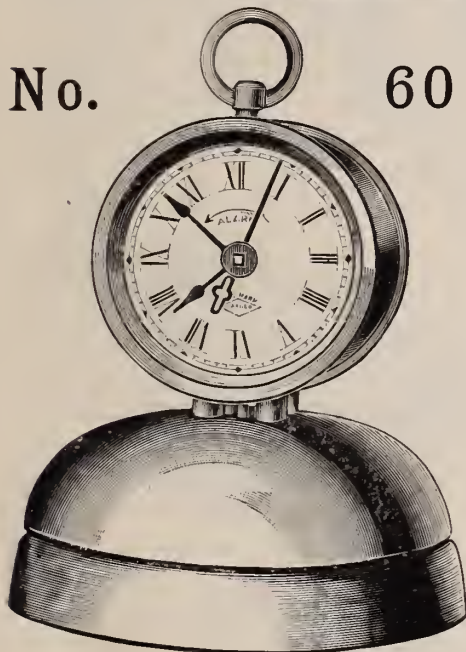

NEW * CONSTRUCTION.

THE ALARM MOVEMENT in these clocks is a New Construction and is superior to any other on account of Improved Escapement.

There is no escape wheel, nor are there any pallets to wear rapidly away, as in all prior alarms.

The sound is Electrical, and it is produced without the expense, care and nuisance of maintaining a Battery.

Sold by all Wholesalers.

THE PARKER & WHIPPLE CO., MERIDEN, CONN.

FALKENAU, OPPENHEIMER & CO.,



40 MAIDEN LANE, NEW YORK.

P. O. BOX 3314.

CHAS. S. PLATT,

1837. Successor to George W. Platt, 1881.

GOLD AND SILVER

Refiner, Assayer and Sweep Smelter.

Office and Refinery,

29 & 31 GOLD ST., near John St., NEW YORK.

Platers' and Electro-Platers' Silver-Platinum and Aluminum.

Workshops to let, with power. Fine Light—specially for Jewelers. All Improvements. Apply as above.

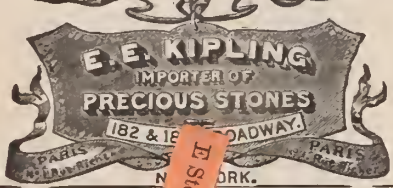

S. P. M. WARD,

Gold and Silver Assayer,

Refiner and Sweep Smelter,

8 & 10 JOHNS STREET, NEW YORK.

Smelting and Refining Works,

28, 30 & 32 CHANDLER ST., Brooklyn, N. Y.

Specialties: Jewels, Gold, Silver and Platinum.

"MONARCH"
THE ROGERS & HAMILTON CO.
WATERBURY, CONN.

ROBERTSON & LEBER,
GOLD, SILVER AND
PLATINUM

REFINING.

PLATINUM SCRAPS MELTED.

13 & 15 FRANKLIN STREET, NEWARK, N. J.

JEWELERS' SWEEPINGS A SPECIALTY.

S. F. MYERS & CO., Wholesale Jewelers

EVERYTHING
THAT
PERTAINS
TO THE
JEWELRY TRADE.

22
DEPARTMENTS.



WE REQUIRE
AND OCCUPY THE
LARGEST
SALESROOMS
IN OUR LINE.
4 STORES.
GROUND FLOOR.

48 & 50 Maiden Lane and 33 & 35 Liberty Street, New York.
CONSULT OUR MAMMOTH CATALOGUES.

L. LELONG & BRO.,

GOLD AND SILVER

Refiners, Assayers and Sweep Smelters,

SWEST CORNER HALSEY AND MARSHALL STREETS,

NEWARK, N. J.

SWEEPINGS A SPECIALTY.

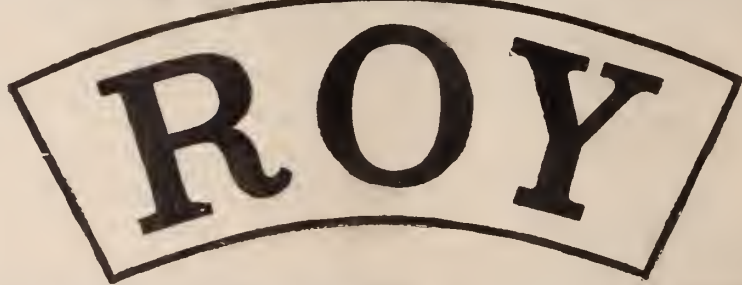

COMPARE ALL OTHER GOLD FILLED CASES WITH THE CELEBRATED CROWN LION EXPANSION H. MURR'S SONS

L. & M. KAHN & CO., Importers of DIAMONDS, 10 Maiden Lane, N. Y.

Gold AND Diamond Jewelry



ODENHEIMER & ZIMMERN
INTERCHANGEABLE INITIAL RINGS
LOCKETS & SLEEVE BUTTONS.
46 MAIDEN LANE, NEW YORK



Gents' Seal,
Ladies' Fancy,
Children's Rings.

ALBERT LORSCH & CO., 37 Maiden Lane, New York. P. O. BOX 2139.

167 Broad St. (P. O. Box 941), Providence, R. I.

IMPORTERS OF

DIAMONDS, PRECIOUS AND IMITATION STONES.

Sole owners and Importers of

Unequaled in

The Sumatra Gem.
REG'D.

Brilliancy.

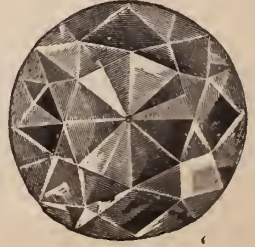
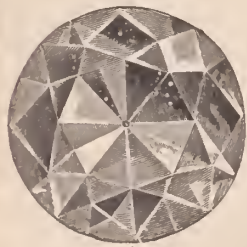

The nearest approach to the Genuine Diamond. For sale by all leading Manufacturers and Jobbers. * All Jewelry set with these Stones is sold on cards stamped "The Sumatra Gem. Reg'd."

Gunzburger Bros., Importers of Diamonds, 35 Maiden Lane, N. Y.

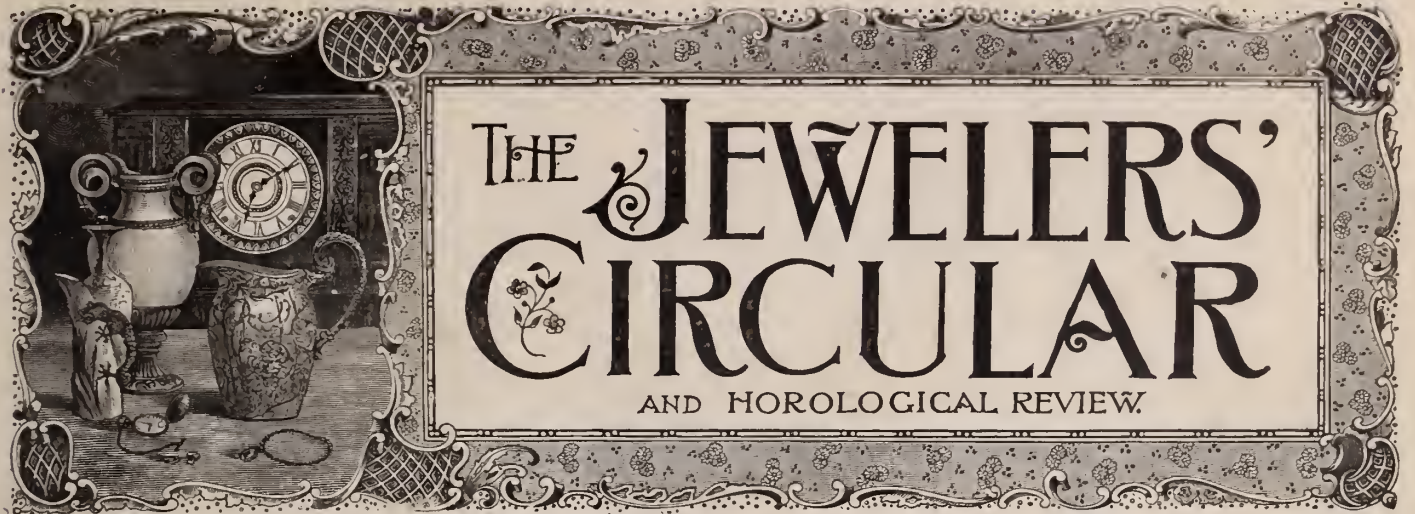

Entered at the Post Office in New York as second-class matter.

VOL. XXII.

NEW YORK, WEDNESDAY, APRIL 29, 1891.

No. 13.

SOUVENIR SPOONS.

PART VI.

IN 1888, when General W. T. Sherman had reached his sixty-eighth birthday, he sat for what he said would be his last photograph, in the studio of Sarony, the celebrated artist. This photograph, which the deceased hero loved more than all the others he had had taken in his lifetime, was reproduced by the hundreds, and the copies were distributed among his many friends, principally G. A. R. veterans. The photograph, which is said to be the best likeness extant of the general, is a three-quarters length one, and shows him in full costume in a sitting attitude.

The Sherman spoon produced by J. H. Johnston & Co., New York, and described in the last instalment of this series, being considered high priced, and a demand being manifested for a Sherman spoon of low or

medium cost, another national spoon commemorating the famous soldier has been produced, which in design equals the first

effect, it being reproduced from the photograph of the soldier, which is before described. Though only in half relief, the

cutting away of the silver between the bust and the wreath gives it the effect of a full relief. Below the bust is seen, in relief, a sword and a palm branch symbolizing death, arranged diagonally over each other. The remainder of the shank is of an attractive twisted, spiral design. The bowl is very attractive, containing etchings of the date of the birth and death of the general, 1820 and 1891, with a facsimile of his autograph between, the

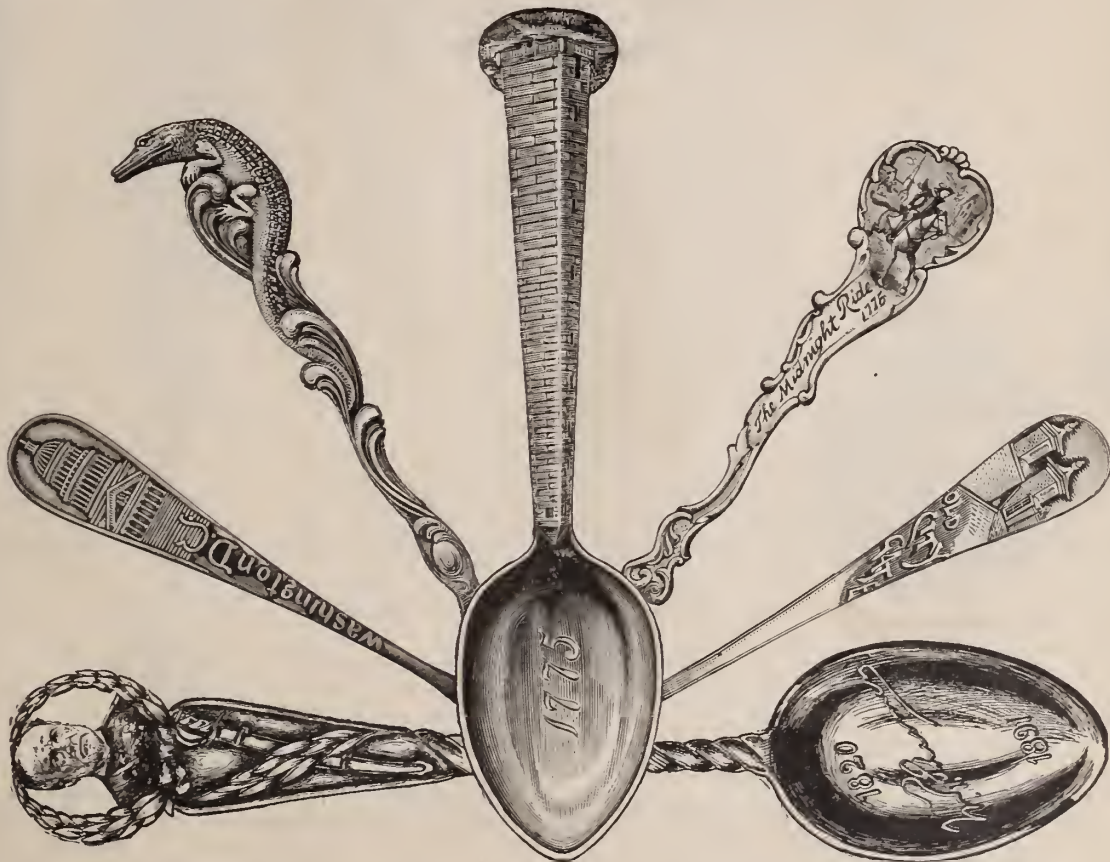

THE SHERMAN, CAPITOL, ALLIGATOR, BUNKER HILL, MIDNIGHT RIDE AND OLD CITY GATE.

being arranged diagonally and parallel. The design of the spoon thus conveys a brief life of the loved soldier. The back is plain. Altogether the spoon, which is made in tea, coffee and orange sizes, shows much

in beauty and workmanship, though it is not so massive and rich in character. At the top of the handle of this new spoon is a miniature of General Sherman surrounded by a wreath of laurels. The likeness is per-

originality of thought, individual character, appropriateness and consistency.

THE GARFIELD MEMORIAL.

Even the youth of the country remember how the world rang with the news of the shooting of James A. Garfield, on July 2, 1881, at the hands of the assassin Guiteau. The President, who had been in office less than four months, lingered until Sept. 19, when he died. Never was there a sorrow so universal as that which followed. To the grief-stricken people of America came words of sympathy from every part of the civilized world. The mournful cortege proceeded to Cleveland, O., to the Lake View Cemetery,

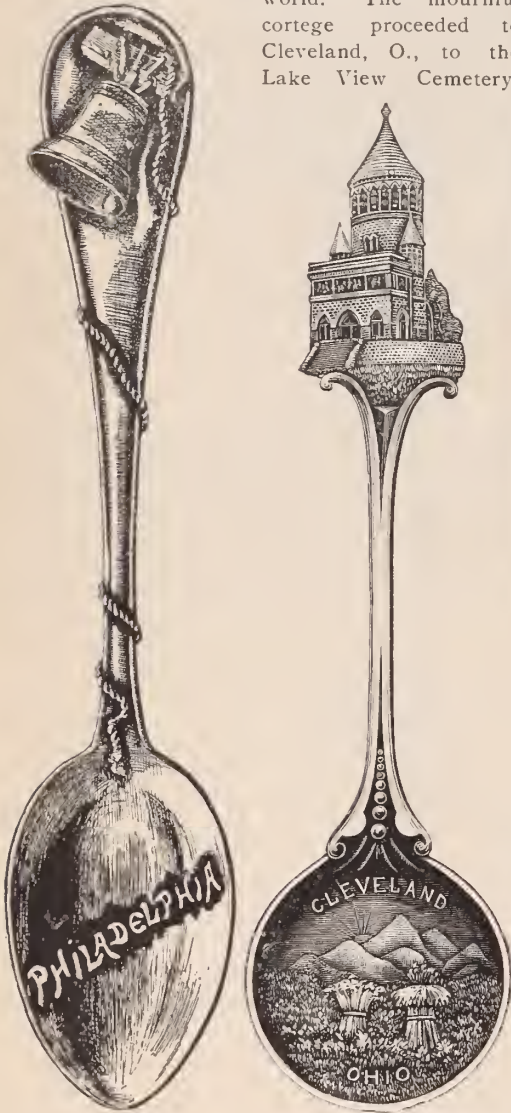

LIBERTY.

GARFIELD MEMORIAL.

where the casket was deposited in a vault prepared for it. This cemetery is to-day a spot of national interest. It is five miles from the city, and commands extensive views. It is here that Garfield expressed his desire to be buried. Here on a knoll his tomb was eventually constructed and a monument reared to him as a mark of the nation's appreciation of his character, and sorrow at his untimely death. The Cowell & Hubbard Co., Cleveland, O., have produced a spoon commemorating this monument and the city of Cleveland, which in richness and elegance of design equals perhaps any spoon produced distinctly as a

souvenir. A miniature of the memorial rests at the top of the handle upon a column of architectural design, forming the shank of the handle. Both ends of the shank are of conventional floral design. In the bowl is depicted the coat of arms of the State of Ohio, the field of wheat with two sheaves in the foreground, and the hills and the rising sun in the background. Above the hills are in raised letters the word Cleveland, and below the sheaves the word Ohio. The workmanship of the spoon is massive in character, the die work of the relief portions being excellent.

THE BUNKER HILL.

It was two months after the first blood of the Revolution was shed at Lexington, that on June 16 Col. Prescott was sent with a detachment of one thousand men to fortify Bunker's Hill. When the British on the following morning discovered the redoubt the Americans had constructed during the night, they commenced a cannonade upon it. This failing, three thousand men, under Howe, were sent to dislodge the Americans. Two charges failed. Gen. Clinton arriving, the third charge was more successful; the Americans, their ammunition exhausted were forced to retreat. About one thousand British and five hundred Americans were killed or wounded. This is an outline of the first real engagement of the Revolution. Upon the site of this battle now in Charlestown now stands the monument, which is considered a feature of Boston. A very attractive spoon has been produced to represent this historical event and memorial by G. E. Homer, 112 Tremont St., Boston, Mass. The handle of the spoon is composed entirely of a miniature of the monument, the head or top of the handle depicting a portion of the surrounding ground. Within the bowl is etched the date, 1775. The workmanship of the details of this spoon is perfect, the representation conveying a graphic idea of famous monument. The oxidizing enhances the general effect.

SCHALL'S CHARTER OAK.

From its first settlement Connecticut has enjoyed the right of self government secured to them in 1662 by Gov. John Winthrop, from King Charles II. The story of how Sir Edmund Andros demanded the surrender of the Charter in 1687, as already told in these columns, is well known to all readers. The oak in which the charter was hidden, ever after to be known as the Charter Oak, has become emblematic of free government. The incident is the most cherished in the history of Connecticut, and it is not strange that more than one dealer should produce a Charter Oak souvenir spoon. The spoon produced by Ernst Schall, Hartford, Conn., is in every respect handsomely and characteristically designed.

Mr. Schall's good taste in art matters is well known.

An odd or graceful object is the first demand, and beyond that the more it means the more it is desired. This Charter Oak spoon is of perfect shape, altogether symmetrical. It is of oxidized silver, enhancing the antique ef-

fect. The whole design is in relief. Inside the bowl is a representation of the old tree, taken from the famous Wyllys' painting, with the words Charter Oak beneath it. Then upon the handle are the dates 1687 and 1689 (the period of the charter), and lower down, 1856, the date of the tree's fall. The Hartford coat of arms, the hart at the ford, is stamped upon the upper part of the handle, and oak leaf and acorn are trained gracefully all about the handle. The whole object is so artistic and suitable that it cannot fail to have a wide circulation as a Hartford memento. The spoon is made in coffee, tea, and orange sizes.

THE LIBERTY.

Hush the people's swelling murmur,
List the boy's strong joyous cry!
"Ring!" he shouts aloud; "RING! Grandpa!
Ring! O RING for LIBERTY!"
And straightway, at the signal,
The old bellman lifts his hand,
And sends the good news, making
Iron music through the land.

The old bellman had posted his little boy at the door of the hall of the State House, to await the instruction of the door-keeper when to ring. At the word, the little patriot scion rushed out, and flinging up his hands shouted the above cry. The old bell is now silent and its iron tongue is hushed, but the spirit it awakened still lives. Tradition tells



LEXINGTON MINUTE MAN.

CALIFORNIA.

us that the old man died immediately after he had performed his task. Whatever may be the numerous traditions connected with the old bell, it now is the principal feature of historic interest in the Quaker City, the stream of brewers being unceasing in the day hours. In the characteristic spoon which Simons, Bro. & Co., 618 Chestnut St., Philadelphia, have produced the bell is seen in high relief at the head of the handle. It is represented as attached to a beam. The

ORIGINAL AND GENUINE
SEAMLESS
FILLED · GOLD · CHAINS.

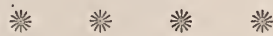

ON account of the many inquiries from our customers asking where they can see our samples in New York, we have decided to open a regular sample office at

17 MAIDEN LANE,

where a competent person will be in charge all the time, with a complete line of our popular goods.

The location is central and very convenient, and we cordially invite out-of-town dealers to make our office their headquarters when in New York.

BOSTON OFFICE,
 6 WINTER STREET,
 I. W. STELLE.

NEW YORK OFFICE,
 17 MAIDEN LANE,
 L. M. MICHELS.

San Francisco Office,
 PHELAN BUILDING,
 WM. E. PETTES & CO.

KENT & STANLEY COMPANY,

PROVIDENCE, RHODE ISLAND.

Address all communications to Providence office.

SOLID SILVER

EXCLUSIVELY.



WHITING MFG. CO.

Silversmiths,

UNION SQUARE and 16th STREET,

NEW YORK.

We make solid silver only, and of but one grade—that of Sterling, $\frac{925}{1,000}$ fine; therefore purchasers secure an entire freedom from false impressions, and the question "Is it silver or is it plated?" is never raised concerning a gift bearing the above trade-mark. We have produced the largest variety of special *Souvenir Spoons* for the trade, made by any silversmith.

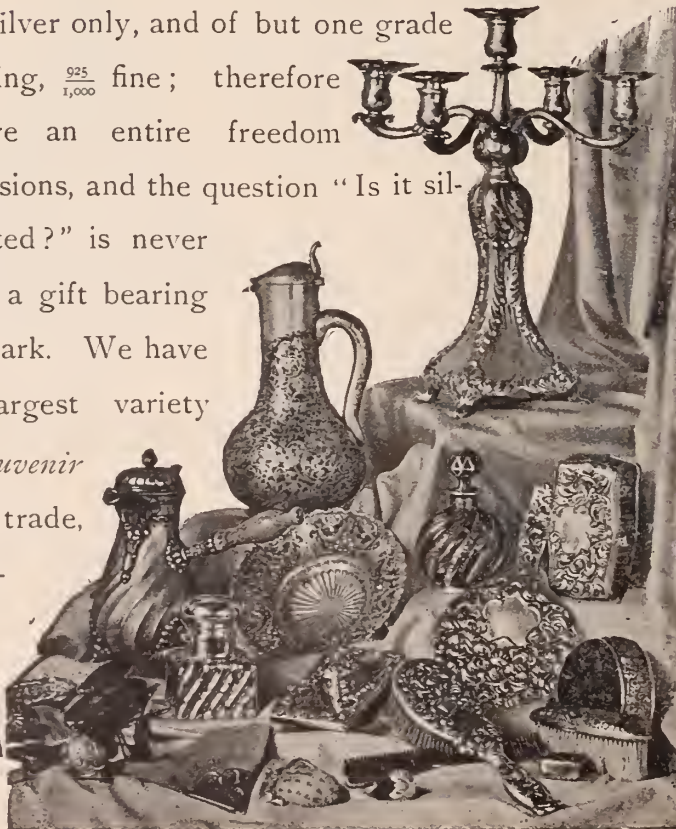

bell rope appears as twining about the shank of the handle, its end running into the bowl. The spoon is very graceful in outline, and the design and execution is extremely artistic. Though the bowl contains the word Philadelphia, the spoon is adapted for sale everywhere as the subject is thoroughly historic and national. It is made in coffee, tea and orange sizes.

THE LEXINGTON MINUTE MAN.

At Lexington, Mass., on April 19, 1775, was shed the first blood of the American Revolution. On the previous night the British, 800 or 900 in number, under Major Pitcairn crossed the Charles River from Boston and landed in Cambridge, taking up their march for Concord. At an early hour the next morning they reached Lexington, and



HOT SPRINGS.

CHARTER OAK.

found assembled on the village green some sixty or seventy "minute-men" to dispute their further advance. The soldiers fired, and the fire was returned by the patriots. Eight of the Americans were killed. The Lexington "minute-man" of 1775 is the pride of America. The device of an armed minute-man was adopted for the town seal of Lexington, and has always been used since. Daniel Low, Salem, Mass., the proprietor of the Witch spoon, has produced a spoon commemorating the event. In the head of the handle is depicted in relief the armed minute-man ready to sacrifice his life in testimony to the rights of mankind; he stands in the field—the village green—with musket uplifted and face set and composed. Along the remainder of the shank is the word, Lexington, in handsome perpendicular letters. The date, 1775, is also stamped at the head of the handle. This handsome historic spoon is made in tea, coffee and orange sizes.

THE PAIRPOINT MFG. COMPANY, NEW BEDFORD, MASS.

Fine Gold and Silver Plated Ware.

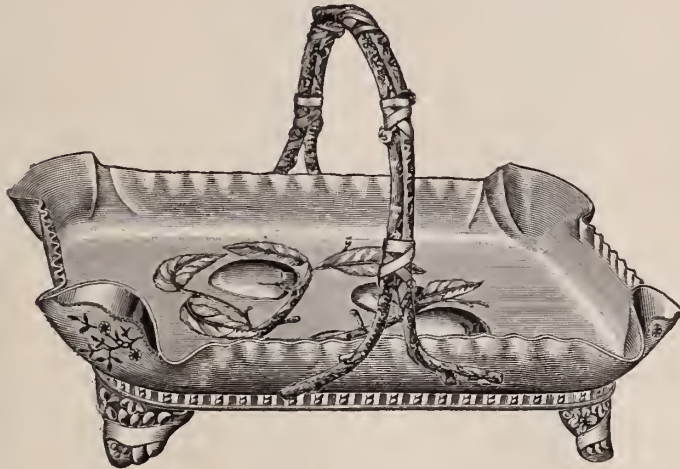

No. 1249. CAKE BASKET.



No. 2954. FLASK.

CATALOGUES AND PHOTOS TO THE TRADE ON APPLICATION.

NEW YORK.

CHICAGO.

SAN FRANCISCO.

PHILADELPHIA

SOUVENIR * SPOONS.

A FINE ASSORTMENT

OF THE

MOST ARTISTIC AND SALABLE DESIGNS.



DAVID F. CONOVER & CO.,

SEND FOR SELECTION.

PHILADELPHIA, PA.

THE CALIFORNIA.

The '49er is an institution of the country; it is safe to wager that any man, sunburnt, with iron-grey hair, sharp features, bright eyes, careless in habit and wearing a broad brimmed hat is a '49er. If he isn't he is apt to say he is, if one suggests the idea to him. It was in the fall of 1847 that Capt. J. A. Sutter began erecting a saw mill at a place called Colorna, on the American river, about fifty miles east of Sacramento. James W. Marshall was at work with his men cutting and widening the tail race when on Jan. 18, 1848, he observed particles of a yellow, glittering substance. In February, specimens of these finds were taken to San Francisco and pronounced to be gold. The truth being soon confirmed, the rush to the gold fields commenced. People in all sections of California and Oregon forsook their occupations and set out for the mines. The news spread, increasing as it went, until the reports grew fabulous. F. M. Whiting & Co., North Attleboro, Mass., have produced an attractive spoon representing this event in history. The handle depicts in relief work the conventional miner shoveling ore into a sieve. The details of the figure are realistically reproduced. The word Eureka (I have found it), applying appropriately to the gold discovery in California, is also stamped on the handle, as are the figures 49. The design is a happy one, as it represents the first impression of California one has in his mind. The California is made in tea, coffee and orange sizes.

THE WENDELL SPOONS.

Hot Springs, Ark., and San Bernardino, Cal., though several hundreds of miles apart, are the Meccas of numerous persons afflicted with rheumatism, sciatica, quinsy and other pleasant complaints. With the early morning everyone rises and makes his or her appearance at the Springs, where they partake of water with a wonderful energy and perseverance. It is said, people get to be fond of this water at last. Whether it is this muddy water or the beautiful climate, combined with the consciousness of freedom from all cares, except his or her own selfish ones, the patient usually returns homeward a healthier being. The period of convalescence is blissful and awakes all the dormant sentiment in the soul; thus, visitors to these places before returning home recuperated, are apt to collect some remembrance of the place in which they regained their lost health. The souvenir spoons, representing these places, produced by the Wendell Mfg. Co., 63 Washington St., Chicago, Ill., are therefore enjoying a good sale. The handles of these spoons are of attractive engraved floral designs, the names of the towns being handsomely etched in the bowl. The spoons are made in tea, coffee and orange sizes. The manufacturers will similarly etch the name of any town or city and year in the bowls of spoons of any make.

THE OLD CITY GATE.

The first European settlement in Florida was made on the St. Johns River in 1564, by

a colony of French Huguenots; but the Spaniards, claiming the whole country, commissioned Melendez to destroy it. After laying the foundations of St. Augustine, in 1565, Melendez proceeded against the Huguenots and massacred them. With the exception of Santa Fé, N. M., which was settled in 1542, St. Augustine is the oldest city in the United States. Some years after the settlement, the Spaniards constructed a fortified wall of coquina about the city, which stands at the present day. The Old City Gate in this wall is one of the features of interest of the United States as well of the town itself. The numerous visitors to the city do not fail to view it, as it is one of the most unique and sentimental sights they have met in their journeyings. The spoon, as seen in the illustration representing this gate, is a very characteristic one. In the top of the handle are seen the parapets where the soldiers of old lay covered from their enemy's shots. The workmanship of the details brings out all the realistic effects. Below the gate are the words Old City Gate, in antique letters. Greenleaf & Crosby, Jacksonville, and St. Augustine, Fla., control this handsome spoon, which is made in tea, coffee and orange sizes. The design is also applied to button hooks, bonbon spoons, and other articles. This house also control the Alligator spoon, illustrated herewith.

THE ALLIGATOR.

A very fine representation of this interesting pet animal is seen on the handle of this

The R. Wallace & Sons Mfg. Co.,



No. 230 CUP. IN STERLING SILVER, TWO-THIRDS SIZE.

MANUFACTURERS OF

Sterling Silver, Plated Ware & Fine Cutlery

FACTORIES, WALLINGFORD, CONN.

{ New York Store: 3 Park Place.
Chicago Store: 104 State Street.

spoon, seemingly in the act of climbing over the top. The details are unusually realistic in the reproduction. The handle itself is extremely handsome, the massive conventionally-shaped leaves in full relief, harmonizing thoroughly with the character of the reptile. The reptile is also in full relief, and is an excellent example of die work.

THE MIDNIGHT RIDE.

Thus says Bancroft of Paul Revere's ride: Warren had already at 10 o'clock detached William Dawes through Roxbury to Lexington, and at the same time desired Paul Revere to set off by way of Charlestown. Revere stopped only to engage a friend to raise the concerted signals, and five minutes before the sentinels received the order to prevent it, two friends rowed him past the Somerset man-of-war, across Charles River. * * * A little below Charlestown Neck, Revere was intercepted by two British officers on horseback; but being himself well mounted he turned suddenly, and leading one of them into a clay pond, escaped from the other by the road to Medford. As he passed on, he waked the captain of the minute-men of that town, and continued to rouse almost every house on the way to Lexington. As pretty spoon as one can conceive, has been produced by Freeman & Taylor, 495 Washington St., Boston, Mass., to commemorate this story, known to even the youngest school child

throughout the land. The outline is in the elegant rococo style. At the head of the handle is seen Paul Revere at full speed, rousing the people. Below, running down a portion of the shank, are the words, The Midnight Ride, 1775, in neat, semi-script letters. The Midnight Ride is made in tea, coffee and orange sizes.

THE CAPITOL.

The opportunity for attractive ideas in souvenir spoons, afforded by the national capital seems to be illimitable. We have already described several spoons representing Washington, and the output seems to still proceed. In this issue is illustrated one, manufactured by F. M. Whittrg & Co., North Attleboro, Mass., which depicts the front entrance of the capitol. The design looks very neat and symmetrical in the head of the handle. The steps, facades and dome are all disclosed. Along the shank of the handle in vertical letters of handsome architectural design, are the words, Washington, D. C. The spoon is made in tea, coffee and orange sizes.

(To be continued.)

The detective force at Tacoma, Wash., recently recovered a large amount of stolen jewelry, and succeeded in breaking up a big gang of burglars. The property recovered consisted of gold rings, bracelets, watches, pins, brooches and necklaces.

The Noise of Thunder Drowned the Smash.

CHICAGO, Ill., April 22.—The store of F. G. Thearle, Jr., & Co., 301 63d St., Englewood, a southern section of Chicago, was robbed early last evening of rings, diamonds, and watch cases valued at \$1,500. At about 7 o'clock that night there was a terrific thunder-storm, the rain came down in sheets, and vivid flashes of lightning cast their lurid glare over the streets, at frequent intervals. While the storm was at its height and the roar of the thunder was loudest, the bold thief smashed one of the plate-glass windows, and snatching a tray of valuables, made a dash for safer quarters.

The clerks in the store at first thought the glass had been broken by the lightning, and little dreamed that it was the work of a bold robber, but the latter was finally seen with the stolen property in his hand, running down the street as fast as he could. He was a sagacious thief, and from frequent business with the police he had learned how to avoid the officers. There is a police station opposite the store, and towards it he ran as offering the best chance of escape; he was followed by several men, but no bluecoats, there being, of course, no officer in the vicinity. He darted down the side of a building, through an arcade and thence made his escape. Detectives have been detailed on the case.

ESTABLISHED 1841.

CARTER, SLOAN & CO.

MANUFACTURERS OF

FINE JEWELRY,

15 MAIDEN LANE,

NEW YORK.

A. CARTER, JR.
A. K. SLOAN.
C. E. HASTINGS.
GEO. R. HOWE.
WM. T. CARTER.



Factory, NEWARK, N. J.

"Why don't you speak for yourself, John?"

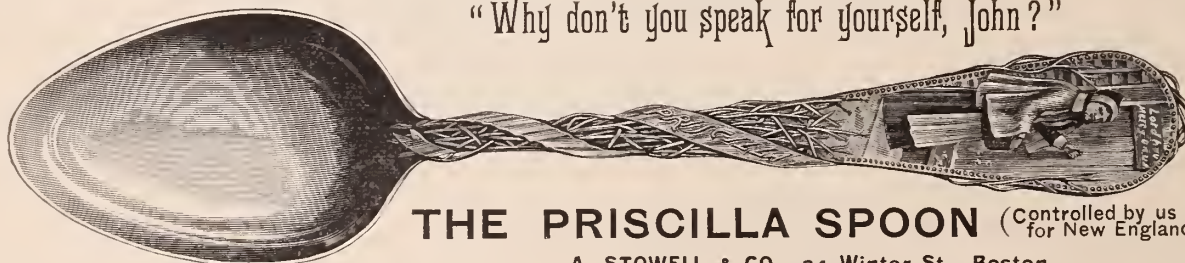

THE PRISCILLA SPOON (Controlled by us for New England.)

A. STOWELL & CO., 24 Winter St., Boston.

"WITCH SPOON" discounts to the Trade. Retail prices as follows: Coffee Spoons, \$1.25, Tea Spoons, \$2.00, Orange Spoons, \$2.25. 25 cents added charge for Gilded Bowls. We believe this spoon conveys the purest sentiment for Engagement Souvenir or Leap Year Purposes. It is difficult to imagine a Souvenir Spoon better adapted to the general demand than the "Priscilla."

As an engagement or sentimental remembrance, embodying as it does Puritan simplicity and maiden sweetness, it has no equal, and we predict a large demand for it as a LEAP YEAR SPOON, for how delicately would a "laggard in love" be stimulated by the gift of a fair counterfeit of her who so naively said, "Why don't you speak for yourself, John?"

CONTROLLED FOR NEW ENGLAND BY

A. STOWELL & CO., BOSTON.

JEANNOT & SHIEBLER

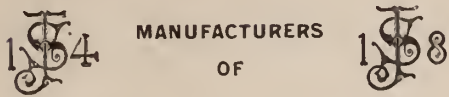

Fine Gold Watch Cases.

No. 20 MAIDEN LANE,
New York.

Constantly on hand, 14k. and 18k. Cases to fit any Movements in the Market.

**GEO. W. SHIEBLER,
SILVERSMITH.**



Artistic Novelties.

HOLLOW AND FLAT WARE.

Sterling Silver

No. 8 Liberty Place,
NEW YORK.

A Large American Emerald.

PROVIDENCE, R. I., April 24.—What is called the largest emerald in the world, save one, has been on exhibition for the past few days in the window of Tilden, Thurber & Co. The largest is owned by the Duke of Devonshire and is a South American gem. The one exhibited in this city, was taken from a mine in Alexander county, N. C. and weighs about 8 ounces.

Edison, the wizard, a few years ago, thought that platinum existed in North Carolina, so he sent W. E. Hidden, an accomplished mineralogist, to search for it. It was a vain search, so far as platinum was concerned, but gem-bearing ground was discovered, and out of it Mr. Hidden took green crystals that looked like emeralds. They differed from the emerald in being hard when mined, lighter and more lucid, and also more brilliant. The new gem was named hiddenite, because of its discoverer.

The huge crystal which is now on exhibition in this city, was found in this mine, Mr. Thurber says upon the authority of Mr. Hidden that it is an emerald, for other gems are found in the Hidden mine besides hiddenite. It is not so deep or dark as South American emeralds.

Swift Justice in Virginia.

CULPEPER, Va., April 24.—On Friday night last, between 11 and 12 o'clock, the store of H. C. Burrows was entered by a thief who broke the glass of the transom over the front door. The thief hearing some one on the outside, escaped through the transom over the back door. A few things of small value were carried off by the burglar.

On Saturday morning William Poole, colored, who was just released from the penitentiary last summer, after serving a three years' sentence, was arrested on suspicion. His case was sent to the grand jury, who heard it on Monday last, found him guilty, and sentenced him to three years in the State penitentiary. Judge Jeffries added five years on account of his having been in prison before. To-day he was sent to the Penitentiary at Richmond.

Large Haul of Jewelry in a Raid.

ST. LOUIS, Mo., April 23.—Detectives Flynn and Badger, about noon, yesterday, in a raid on the second-hand store of Harris Asher, 717 Morgan St., recovered jewelry valued at about \$1,000, all of which is supposed to have been stolen. Never before in the history of the city has a larger amount of jewelry been captured in a raid. As a result, Asher, the proprietor, and Harris Miller, a second-hand dealer, 805 Morgan St., were arrested on a charge of receiving stolen property, but were released on bond.

The arrest of the two came about through an examination of the stock and the conflicting stories of how it was obtained. Asher was first taken in custody, after claiming that it belonged to him. After he had been notified that Chief Desmond wanted to see him, he called out to a passing friend to go to the

J. F. FRADLEY & CO.,

Manufacturers of a General Line of

REPOUSSÉ SILVERWARE, MATCH BOXES in Solid Gold and Stiffened Gold,
GOLD HEADED CANES, &c.

Office and Salesroom, 23 JOHN STREET, NEW YORK.

THE Special Notice columns of THE JEWELERS' CIRCULAR bring better results for a small outlay of money than any medium in the jewelry trade.

TRY THEM.

Magic Repair Clamp,

FOR ALL KINDS OF JEWELRY JOBBING.

PRICE, \$1.25.

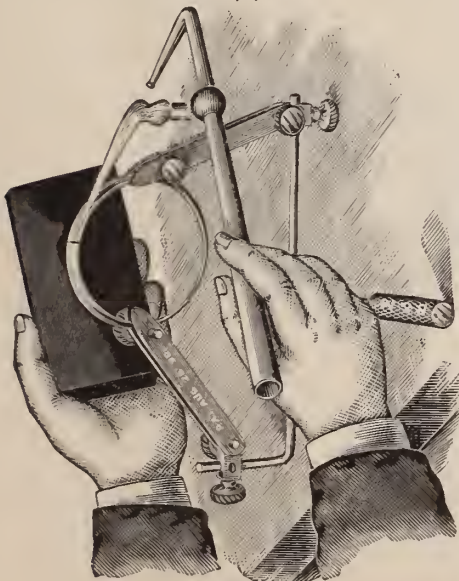

M. MYERS,

7 BROMFIELD ST., BOSTON, MASS

The Midnight Ride, 1775,

∴ SOUVENIR SPOON. ∴

(For cut see first page.)

"Listen my children and you shall hear,
Of the Midnight Ride of Paul Revere."
Longfellow.

For beauty of design and excellence of workmanship, this spoon is equal if not superior to any now on the market. It is admitted by all who have seen it to be the

ONLY BOSTON SPOON

that possesses any real merit.

PRICES.

Tea Spoons, plain Bowl	- - - -	\$2.50 each
gold	- - - -	3.00 "
Orange " plain "	- - - -	2.75 "
gold	- - - -	3.00 "
Coffee " plain "	- - - -	1.50 "
gold	- - - -	1.75 "
Discount to the Trade.		

We are also proprietors of the

"JOHN HARVARD" SPOON.

Selling from one end of the country to the other.

FREEMAN TAYLOR,
495 Washington St.,

BOSTON, MASS.

(Cut of this Spoon shown on first page.)

CUT OF THIS SPOON IS SHOWN ON FIRST PAGE.

store of Miller and tell him of the arrest. That action aroused the suspicion of the detectives, and they proceeded to Miller's place of business. When asked what connection he had with the jewelry, he said that it belonged to him, and that he had borrowed \$500 from Asher on it, and given it as security. That convinced the detectives that he knew more about it, and he was also taken in custody.

The thefts undoubtedly extend over the last ten years. The property can be secured on identification.

A Jewelers' Security Alliance for the Dominion.

MONTREAL, P. Q., April 24.—J. A. Grose, of the Canadian Secret Service, has organized a Dominion Jewelers' Security Alliance on the lines of the Jewelers' Security Alliance in the United States. The object of the Alliance is to render the best possible detective service to those whose safes may be burglarized and the restitution of property when possible.

The membership fee is \$10 and the annual dues \$50. Any person or firm engaged in the jewelry or kindred trades is eligible to membership. Mr. Grose guarantees to take charge of all cases of robbery committed on a member of the Alliance and to pay all costs in connection with the detection and prosecution of criminals. The or-

ganizer has issued circulars and has already secured a membership of about twenty including some of the best known jewelers in the city.

Will no Longer Search for Swenson.

MONTREAL, P. Q., April 23.—The body of Montreal's missing jeweler, Carl Swenson, as mentioned exclusively in THE CIRCULAR last week, was found, after a disappearance of ten weeks in the snow on a suburban road. The body was only slightly discolored, except the face, which was quite black. On the body were found, besides his \$200 diamonds, a loaded revolver, bunch of keys, safe key and twenty cents in silver.

The verdict of the coroner's jury was, "that the deceased met his death from exposure to the cold, pulmonary congestion and by the visitation of God." The funeral took place yesterday and was attended by a number of the craft. Swenson leaves \$10,000. The \$100 reward has been paid to the finder, a farmer.

A Club Agent in the Toils.

NEW ORLEANS, La., April 22.—S. F. Powers, agent of the Southern States Watch Co., Common and Camp Sts., was arrested on Sunday and locked up, charged with obtaining money by false pretenses. The complainant is Patrolman Nox, who was a subscriber to the club. He had paid in \$40, then claimed the watch; he was given for

an answer that the watch company had not received any watches from Chicago, where the executive office is located.

As this reply did not prove satisfactory, Nox swore out an affidavit against the representative of the company, S. F. Powers. The accused was arraigned before Recorder Bringier, and placed under \$150 appearance bond.

C. F. Pierce Buys an Old Established Business.

SPRINGFIELD, Mass., April 24.—The long-established jewelry manufacturing establishment of N. Howard & Son, 29 Hillman St., has been sold to C. F. Pierce, formerly of J. R. Greason & Co., New York. Howard & Son have been engaged in business here for about thirteen years, and have met with fair success.

The new proprietor was formerly employed in this city, at the chain manufactory of Arthur, Rumrill & Co., and is therefore acquainted in Western Massachusetts. It is his intention to push his business as much as possible, and will open a branch office in New York.

R. H. Robinson, of Doering & Robinson, Anniston, Ala., who has been a sufferer for several years from a pulmonary complaint, has been pronounced cured by the Koch lymph treatment.

H. A. WADSWORTH & CO.

MANUFACTURERS OF

GOLD · FILLED · WATCH · CASES,

NEWPORT, KY.

The Creditors of J. Steinmetz Jewelry Co.

HELENA, Mont., April 27.—The assignment of the J. Steinmetz Jewelry Co., of this city, which was announced in the last issue of THE CIRCULAR was caused, it is said, by the loss of \$8,000 which John Steinmetz recently suffered owing to the closing of the Atlantic Garden at Butte, this State. Assignee Bailey is of the opinion that the liabilities will be fully covered by the assets.

The list of creditors contains the following: Groeschel & Rosman, New York, \$269.50; Unger Bros., New York, \$149.50; Enos Richardson & Co., New York, \$70.75; Meriden Silver Plate Co., Meriden, Conn., \$325.43; Myrick, Roller & Holbrook, Philadelphia, Pa., \$326.10; L. H. Keller & Co., New York, \$49.76; M. Myers, Boston, Mass., \$65.80; C. G. Alford & Co., New York, \$33.50; Whiting Mfg. Co., New York, \$18.93; Kremetz & Co., Newark, N. J., \$645.25; F. Kroeber Clock Co., New York, \$601.19; Wilcox Silver Plate Co., Meriden, Conn., \$925.05; D. F. Foley & Co., New York, \$6.64; Benj. Allen & Co., Chicago, Ill., \$199.44; Theo. Gribi, Chicago, Ill., \$20.50; Carter, Sloan & Co., New York, \$183.06; G. F. Wadsworth, Newport, Ky., \$11.70; S. H. Clausin & Co., Minneapolis, Minn., \$182.84; Ernest Adler, New York, \$38; C. L. Abry, New York, \$715.05; California Optical Co., \$778.58; Aurora Silver Plate Co., Aurora, Ill., \$24; Gorham Mfg. Co., New York, \$30; L. J. Glaenzer & Co., New York, \$381.13; J. F. Fradley & Co., New York, \$246.69; L. W. Fairchild & Co., New York, \$657.76; D. C. Dodd, Newark, N. J., \$50; Block & Bergfels, New York, \$662.85; J. Bernstein & Co., New York, \$607.25; Meriden Bronze Co., Meriden, Conn., \$64; Frank Haviland, New York, \$470; H. W. Wheeler & Co., New York, \$148.73; Oppenheimer Bros. & Veith, New York, \$270.10; Weis & Oppenheimer, New York, \$332.62; Spencer Optical Mfg. Co., New York, \$303.44; Sussfeld, Lorsch & Co., New York, \$200.62; Simons, Bro. & Co.,

Philadelphia, Pa., \$141.05; Hirschberg Optical Co., Kansas City, Mo., \$366.94; J. B. Mayer & Co., Buffalo, N. Y., \$1,050; Gunzberger Bros., New York, \$739.09; M. B. Bryant & Co., New York, \$27.50; Falkenau, Oppenheimer & Co., New York, \$240.55.

PROVIDENCE, R. I., April 25.—Among the forty-eight creditors named in the assignment of the John Steinmetz Jewelry Co., Helena, Mont., are the Kent & Stanley Co., \$221.43, and the Sterling Co., \$788.57. It is estimated that the loss in this city will not exceed \$2,500 or \$3,000.

Working Jewelers Want to Combine.

The workshops in the New York jewelry manufacturing district have of late been flooded with circulars of the Jewelry Makers' Union No. 1 of New York in which it is stated that, "while the workmen of all countries are united and struggle for better wages and shorter hours, the jewelers stand outside of the ranks of organized labor." Two meetings were recently held at Pacific Hall, 209 E. Broadway, one on the evening of April 19 and the other last Tuesday, at which the jewelers were addressed in English and German and urged to get together and fight against the present alleged low wages. Among the speakers were Abe Cohen and Mrs. Greic. The union was organized some

time ago but fell somewhat into oblivion, and at the first meeting it was resolved to take back all former members of the union without charging the initiation fee.

Several manufacturers with whom a CIRCULAR reporter conversed on the subject, were of the opinion that working jewelers could never perfect a successful union to regulate wages. The trade is so divided into different classes that it would be impossible to fix a standard scale of wages. The majority of the manufacturers seen thought that the union would never prove a power in the trade. Some, however, advocated the organizing of the employers as an offset. One said: "It's anything but pleasant to contemplate the coming of a stranger into your workshop who has more to say about your affairs than you have yourself. It is not now that we have to fear the union, but during the fall of the year when we want every man we have working. Manufacturers should organize now to meet any demand made a year hence."

Hollinshed Bros. to be Sold Out.

PHILADELPHIA, Pa., April 26.—The business of Charles Hollinshed, trading as Hollinshed Bros., wholesale jewelers, 806 Chestnut St., will, on May 1, be sold out by the sheriff to satisfy the creditors. Yesterday Charles Bell, who is charged with being the

NEW SHAPE. NEW CUT.

WATER BOTTLE.

Can be seen at the
CUT-GLASS SHOWROOM OF
T. B. CLARK & Co.,
53 PARK PLACE, NEW YORK.

THE WORLD'S FAIR CITY SPOON.

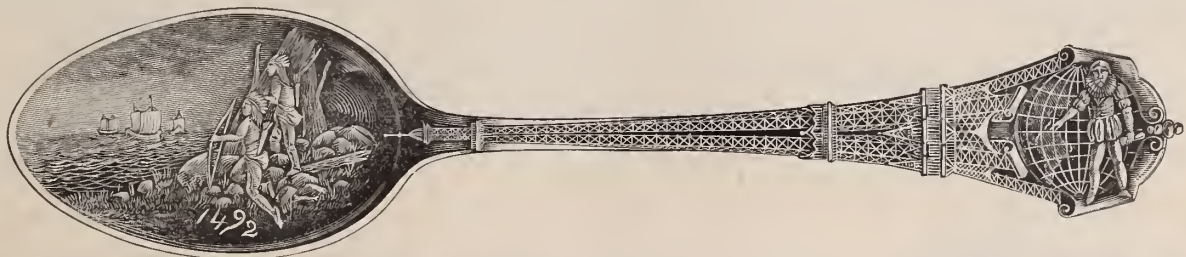

Indians watching the approach of the Columbus fleet | The Proctor Steel Tower to be erected on the World's Fair Site, Chicago, 1892. | Bas-Relief figure of Columbus; the Western Hemisphere as a background.

An entire novelty in Souvenir Spoons. Interesting to every patriotic American, to every Antiquarian, to every Curio-collector, to every boy and girl in the United States, and therefore sure to command a ready sale throughout the country.
MADE ONLY IN TEA SIZE. X X X LIBERAL TERMS TO THE TRADE.

Send for Sample to *Pelly, Curtis & Co.* Proprietors,
JEWELERS, **No. 95 WASHINGTON STREET, CHICAGO.**

cause of the firm's embarrassment, occupied the prisoner's dock at the City Hall Police Court, upon the charge of larceny. Last week, when Mr. Hollinshed failed he attributed the difficulty to systematic thefts carried on by an employee, and Bell was arrested on Friday night at the instance of Detective Donaghy.

In the possession of the accused were found pawntickets for three watches and a diamond stud, which were recovered by the detective. Bell had been employed by the firm as a salesman for about three years, and during that time quite a number of articles disappeared. Suspicion fell on the prisoner two weeks ago, and he was discharged. It is believed by Mr. Hollinshed that the firm lost considerable property through Bell's pilferings, and it is said other jewelers were treated the same way by the man, but the cases were settled by Bell's brother. The prisoner was held by Magistrate Clement under \$1,000 bail for a further hearing on the 29th.

Peculiar Workings of the Canadian Customs.

MONTREAL, P. Q., April 23.—During January of this year the Keystone Watch Case Co., Philadelphia, Pa., decided to drop the

manufacture of the Cyclone watch case. This case is aluminum, and was originally worth \$5 less 15 per. cent. The company decided to drop the price and find a purchaser for the 3,000 cases which were still in their factory.

Smith & Patterson, of Boston and this city, were offered the deal, and they finally came to the conclusion that they could handle the cases through their Candian agent, A. A. Abbott. The gentleman was consulted and he took one of the cases and called on Appraiser Ambrose.

Mr. Abbott talked the matter over with Mr. Ambrose and the latter made many inquiries.

In the first place he was told that the open face case was bought for \$2.52 and the hunting case for \$2.65. Mr. Ambrose worked very hard, and at last found that the cases could actually be bought in the States for the prices named by Mr. Abbott. He said he would admit the whole consignment of 1,819 cases at the invoiced prices if they were shipped into Canada at one time, thus forcing a payment of about \$1,900 in one lump.

Mr. Abbott wrote this proposition to the firm. Naturally they complained at an attempt to force them, but finally the deal was closed, the goods shipped, the \$1,900 duty paid, and the watch cases lay safe, for the

time being, in the warehouse of Smith & Patterson, in this city. This was in February and during the remainder of the month, and that of March a part of the cases were disposed of.

The other day, a special Customs agent, named Belton of Toronto, Ont., seized the cases and placed them in the Customs House. He next sent word that the goods would be delivered if a deposit of \$7,291 were made. The law, it is claimed, does not bear the special agent out.

The Montreal *Herald* has taken up the case and scathingly denounces the ways of the customs officials. The paper demands an explanation, which has not yet been given. Meantime it is printing from one to two columns of interviews per diem against the whole system. The *Herald* claims that having the laws understood will be the first step towards having them modified.

W. F. Nye, who made an exhibit of his watch and clock-oils at the Paris Exposition, has just received a handsome bronze medal from the Board of Managers, for the best exhibit from all parts of the world. Mr. Nye now has eight bronze medals and five diplomas of award as a result of his competition in as many exhibitions.

MATHEY BROS., MATHEZ & CO.

16 MAIDEN LANE, N. Y., AND BRASSUS, SWITZERLAND,

MANUFACTURERS AND IMPORTERS OF

Plain and Non-Magnetic Movements.

Complicated Watches a Specialty.



REPEATERS

**CHRONOGRAPHS,
MINUTE REPEATERS,
AND
SPLIT SECONDS,**

IN ALL GRADES AND SIZES.

SOLE AGENTS FOR

H. L. Matile, C. H. Meylan and J. J. Badollet. Watches Demagnetized.



CHRONOGRAPHS.

**THE "FORT PITT" SOUVENIR SPOON
OF PITTSBURGH.**

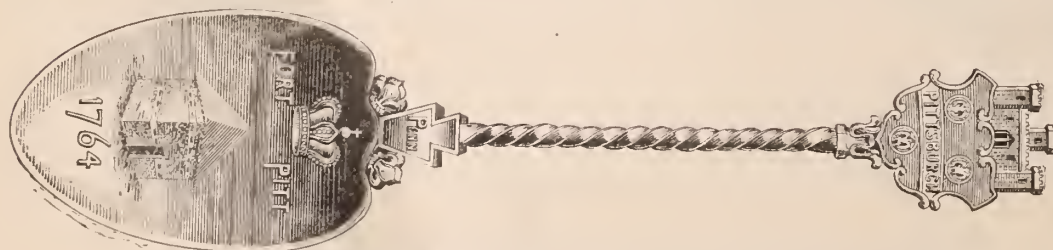

E. P. ROBERTS & SONS,

Fifth Ave. and Market St., Pittsburgh, Pa.

PATENTED 1891.

DISCOUNT TO THE TRADE.

It's many historical features dating from the Indian, French and English possession of Pittsburgh, during the time of Washington, Braddock and Boquet, will make it a Souvenir of national interest.

Made in Sterling Silver—heavy weight—odd shape bowl—Price, \$3.00.

Fancy Dials.

A significant feature of the present Watch business is the increasing demand for Fancy Dials. Anticipating this tendency, we placed our orders very early in the season with both foreign and domestic manufacturers, and are now showing a most interesting and complete variety. We have these Dials at present on 18, 16 and 14-size Waltham Movements, 18, 6 and 0-sizes Elgins, 18-size Howards, 18 and 6-size "Nassau" Movements, the entire "Lady Racine" Chate-laine line, the "Gem" Chatelaines and even on cheap 18 lign Silver Cylinders. The prices vary from 50 cents to \$4.75 extra, according to quality of material and character of work. The Dials include Enameled Porcelain, Transparent Porce-lain, Fancy Underglazed, decorated in Bird, Flower and Landscape designs, etc., etc. The artistic elegance of the work throughout indicates the permanency of the fashion, and enterprising jewelers will endeavor to be first in the field in showing a line of these exquisite fancies.

Bowman & Musser,

Importers and Jobbers,

Watches, Chains, Spectacles, Tools and Materials,
Lancaster, Pa.



MUELLER'S ARTIFICIAL EYES
ARE THE BEST IN THE

M. ZINEMAN & BRO.,

130 So. Ninth Street, Philadelphia, Pa.,

Sole American Agents.

Quantities Sent For Selection'



JAMES P. SNOW.

ESTABLISHED 1834.

CHAS. E. WESTCOTT

SNOW & WESTCOTT,

SUCCESSORS TO G. & S. OWEN & CO.
MAKERS OF

FINE JEWELRY,

Lace Pins, Ear Rings, Scarf Pins, Sleeve Buttons, Sash Pins, Collar Buttons, Bracelets, Studs.

All Goods sold by us are exclusively of our own manufacture and are warranted 14 K. Fine, and stamped as such when possible.

No. 3 MAIDEN LANE, NEW YORK.

THE "HENDRIC HUDSON" SOUVENIR SPOON OF TROY, N. Y.

In Honor of the Discoverer of the Hudson River.

Whether Hendric Hudson discovered the river that bears his name is a question, but one thing is certain that it was named after him. He is reported to have sailed up the Hudson in his Dutch Galiot, the "Half Moon," to Troy, in 1609, and hence his old Dutch Vessel and a half-moon have become emblematic of Troy, he really being the first white man who visited this vicinity, and as a crest for a local spoon it is very appropriate.

When supplemented with a medallion upon the handle in which Hans (or Yacup) are shown lazily sitting upon a keg of schnapps, the illustrated spoon becomes historic in appearance. Made in Tea, Coffee and Orange sizes. Send for Circular and Price List.



JAMES W. CUSACK, Jeweler, No. 3 Times Building, Troy, N. Y.

N. KOCH.

L. DREYFUS.

J. KOCH.

I. PFORZHEIMER.

IMPORTERS OF

Diamonds

KOCH & DREYFUS,

22 John Street, New York.

JOBBERS OF

Watches & Jewelry.

ESTABLISHED 1865.

N. J. FELIX,

MANUFACTURER OF

GOLD AND SILVER WATCH CASES,

ROOMS 6, 7 AND 8,

71 Nassau Street, N. Y. City.

REPAIRING CASES (no matter how badly damaged) A SPECIALTY.

BEECHER & CLARK,



Engravers,

Designs and Estimates Fur-nished on Application.

352 JEFFERSON STREET,

Guthrie Block,

LOUISVILLE, KY.

ALVIN MFG. CO.,

* SILVERSMITHS, *

860 Broadway, New York.

206 Kearney St., San Francisco.

Factory, NEWARK, N. J.

DAY & CLARK,

MAKERS OF

FINE JEWELRY,

BEAD NECKS AND BEAD BRACELETS

CURB AND LINK BRACELETS

STRICTLY 14 KT.

10 MAIDEN LANE. N. Y.

THE BOWDEN Seamless Plain Ring,

IS MADE ONLY BY
J. B. BOWDEN & CO.,

Makers of FINGER RINGS of
every Description,
COR. BROADWAY & JOHN STREET,
NEW YORK.

ESTABLISHED 1873.

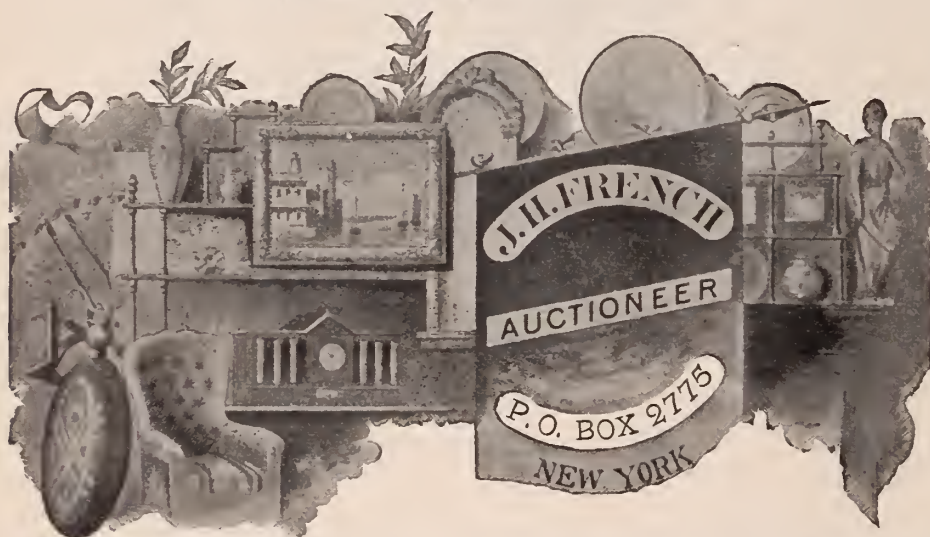

If for any reason you should desire the services of an AUCTIONEER, and will write me as to the amount of stock you have on hand and its general character, the size of your store and the number of inhabitants of your town or city, I could, from my extended experience, give you an idea of the amount of business you could expect under the circumstances, and, no doubt, be able to refer you to some one for whom I have sold under conditions similar to your own.

As a general reference, you could hardly find a wholesale jeweler who is not familiar with some of the numerous successful sales I have made.

I have made many successful AUCTION SALES, and have yet to record a failure to fully satisfy the owners. Can give you hundreds of references to that effect.

If the business should be urgent and I am myself engaged, I have two competent assistants instructed in my methods whom I could send on short notice.

Any correspondence with me will be strictly confidential in every case.
P. O. Box 2775.

NEW YORK CITY.

SEXTON BROS. & WASHBURN,

41 MAIDEN LANE, NEW YORK,

MANUFACTURERS OF

FINE JEWELRY,

INCLUDING A FULL LINE OF MOUNTINGS.

PROMPT AND CAREFUL ATTENTION GIVEN TO SPECIAL ORDER WORK.

Arrested for the Homestead Burglary.

PHILADELPHIA, Pa., April 22.—One of the persons charged with participation in the burglary of the jewelry store of J. F. Schmitt, Homestead, this State, in January last, was arrested Monday night at Frankford. His name is Daniel S. Dever. The burglary is the one which led to the killing, by Jack Fitzsimmons, of Detective Gilkinson, of Pittsburgh, who was working upon the case, and the shooting of Detective Murphy, who was assisting him.

The police, several days ago, were directed to look out for Dever, the 21-year-old son of Patrick F. Dever, of Edmund St., Frankford, who was wanted on a charge of burglary. In the early part of last week, Dever, who had been absent since December last, returned home, but kept out of sight.

Dever declares his entire innocence of complicity in the robbery. He admits, however, that for several weeks prior to the robbery he boarded at a saloon kept by a man named Shaw, immediately opposite Schmitt's store, but says that, by a singular coincidence, he left Homestead on the very night of the robbery and went to Pittsburgh. He was charged in December last by Jeweler H. M. Betz, of Frankford, by whom he was at one time employed, with swindling him out of a quantity of jewelry, but the affair was fixed up.

At the hearing before Magistrate Pole, Dever appeared very cool and evinced little concern when he was committed to await the action of the Allegheny County officials.

Commendable Pawnbroking Ordinance.

MEMPHIS, Tenn., April 22.—On Monday the new amendment to the ordinance governing the pawnbroking business in this city, which was recently enacted, went into effect. The new law bears directly upon the local jewelry trade, which has been considerably affected by petty robberies for some time past. The amendment requires that an itemized statement of all articles received in pawn by them shall be given to the chief of police every morning. Its object is to enable the police to more readily trace stolen property. It reads as follow:

Every person engaged in the pawnbroker's business shall prepare and deliver to the chief of police every day, before the hour of 9 o'clock, A. M., a legible and correct copy from such registry of the description of all property, bonds, notes, or other securities received on deposit or purchase during the preceding day, with the name of each party making a deposit or pledge, together with the hour at which the article was received, together with the description of the person by whom left in pledge or from whom the same was purchased. No bond, note, security or personal property of any kind received on deposit, purchased or pledged by any such pawnbroker shall be sold or permitted to be redeemed or removed from the place of business of such pawnbroker for the space of twenty-four hours after the copy and statement provided for in the last section has been delivered.

American Precious Stones of 1889.

WASHINGTON, D. C., April 22.—The Census Office of the Department of the Interior have just issued a Bulletin of precious stones and diamond cutting, prepared by G. F. Kunz, special agent, under the supervision of Dr. D. T. Day. This important field has never been covered by any preceding census.

From the Bulletin the following tables are taken:

PRODUCTION OF PRECIOUS STONES, ORNAMENTAL MINERALS, ETC., IN 1889.

NAMES OF GEMS OR PRECIOUS STONES.	Value of stones before cutting.	Value of stones after cutting into gems for ornamental purposes.	Value of stones sold as specimens and curiosities, occasionally polished to beautify or show the structure.	Total value.
Total.....	\$107,645	\$81,162		\$188,807
Sapphire.....	\$2,600	6,725		6,725
Emerald.....		300	150	450
Aquamarine...	225	597	150	747
Phenacite.....			200	200
Topaz.....	100	200	200	400
Turquoise....	10,000	23,175	500	23,675
Tourmaline...	1,030	2,250		2,250
Garnet.....	510	1,633	675	2,308
Quartz.....	510	2,750	11,250	14,000
Amethyst.....	15	98		98
Rose quartz...	200	400	200	600
Smoky quartz.	700	4,007	225	4,232
Gold quartz...	6,000	9,000		9,000
Rutilated quartz	2	30		30
Dumortierite in quartz			250	250
Quartz coated with chalcodony.....	1,000	2,000	2,000	4,000
Chrysoptase..	50	200		200
Agatized and jasperized wood.....	42,725	53,000	175	53,175
Banded and moss jasper.....		80	550	630
Amazon stone.....			500	500
Pyrite.....	100	500	1,500	2,000
Chlorastrolite.	200	300	200	500
Thomsonite...	100	200	200	400
Fluorite.....			500	500
Fossil coral...	100	200	500	700
Azurite and malachite..			2,037	2,037
Monazite (a)...	1,000		1,000	1,000

DIAMOND-CUTTING INDUSTRY.

STATES.	Number of works.	Weight of material before cutting. (Carats.)	Weight after cutting into watch jewels, and for mechanical uses. (Carats.)	Value after cutting into gems.	LABOR AND WAGES.					Total wages.	Value of machinery used in cutting.	
					Number of men employed.	Average wages per day.	Average number of days employed.	Number of boys employed.	Average wages per day.			Average number of days employed.
Total.....	19	54,344	25,005	\$1,006,716	167	\$3.55+	233	69	\$0.66+	216	\$148,114	\$77,050
Massachusetts.	3	4,100	1,580	41,000	11	4.10	300	4	1.17	300	14,934	3,000
New York.....	16	50,244	23,425	995,716	156	3.49	229	65	0.62	211	133,180	74,050

The Jewelers' Security Alliance.

At the meeting of the Executive Committee of the Alliance, held last Tuesday, the following applicants were admitted to membership: J. S. Gratz, 175 E. Madison St., Chicago, Ill., L. A. West, Manitou Springs, Col., Adolph Enggass, 78 Woodward Ave., Detroit, Mich., Roulet & Baker, 305 Summit St., Toledo, O., Chas. Kalbow, 207 Broadway Brooklyn E. D. N. Y., A. F. Siedle. 11

Frankstown Ave., Pittsburgh, Pa., August Roggenkamp, 1462 Third Ave., New York, and Wm. Keck, 4 Western Ave., Muskegon, Mich.

Death of Philip L. Moen.

WORCESTER, Mass., April 23.—Philip L. Moen, president of the Washburn & Moen Mfg. Co., the biggest wire manufacturing concern in this country, and manufacturers of clock springs, died at his home in this city this afternoon, aged sixty-seven years. He was born in Wilna, N. Y., and in 1846, married a daughter of Ichabod Washburn, of this city, who four years later took him into partnership in the manufacture of wire.

The present corporation was formed in 1863, and since the death of Deacon Washburn, twenty-one years ago, Mr. Moen has been president. He was a sterling Republican, and was one of the Blaine electors in 1884. He was noted for his benevolence, and gave liberally to various charitable and educational institutions in this vicinity. He was one of the trustees of the Worcester Polytechnic Institute and president of the Washburn Memorial Hospital.

A Clever Swindler Trapped and Jailed.

WASHINGTON, D. C., April 22.—The diamond swindler who worked a successful game in Baltimore, Md., last week, was captured yesterday in this city. He gave his name as Walter Gray. His method was to insert in a paper an advertisement to the effect that a gentleman would like to borrow some money on diamonds as security. This advertisement was answered by a Mr. Morrison and a Mr. Bergman. From the former he obtained \$800 and the latter \$650.

Mr. Morrison was taken by the swindler to the store of Justis & Armiger, 31 E. Baltimore St., and a pair of stones shown him, which, Gray said, were worth \$600.

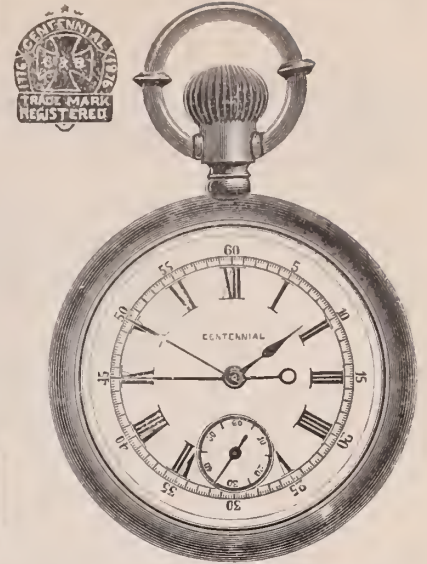

"THE CENTENNIAL"

LEADS THEM ALL.

Acknowledged by all dealers to be the best Chronograph in the Market. Made also as a Plain Timer.

Ask your jobber for them, or order of the Manufacturers,

CROSS & BEGUELIN,

21 Maiden Lane, N. Y.,

IMPORTERS OF
**DIAMONDS, WATCH MATERIALS,
OPERA GLASSES, Etc., Etc.**

Jobbers of all grades of American Watches,
Gold and Rolled Plate Jewelry.

SEND FOR PRICE LIST.

NEW GOODS—STERLING SILVER.

Spring Novelties.

Lewis Brothers,

41 Maiden Lane, New York.

ESTABLISHED 1837.
GEO. O. STREET & SONS,
MAKERS OF

Fine Rings, Lockets, Seals, Sleeve Buttons and Links,
15 John Street, - NEW YORK.

WOOD & HUGHES,
Sterling Silverware Manufacturers.
New York Agents for the Derby Silver Co.'s
FINE QUADRUPLED PLATED WARE.
No. 16 JOHN STREET, - NEW YORK.
206 Kearney St., San Francisco, Cal.
HASKELL & MUEGGE, Agents.



No collection of Spoons will be complete without our
 BEAUTIFUL HISTORIC SILVER SOUVENIR SPOON
THE "BEVERWYCK"
 (Early name of the City of Albany.)

THE ornamentation on the handle of this exquisitely wrought spoon, includes an accurate representation of the famous Capitol at Albany, N. Y. A MAGNIFICENT STRUCTURE, the PRIDE AND GLORY of the "EMPIRE STATE," which has been over twenty years in building, and has cost nearly *twenty millions of dollars*. The above Spoons are made of Sterling Silver, are of good weight and can only be purchased of us. We will send them prepaid to any address on receipt of price, with privilege to return if not perfectly satisfactory. For five cents additional, we will insure safe arrival of package.



Orange Spoon { Plain Bowl, \$2.50
 Gold Bowl, 2.75

Tea Spoon { Plain Bowl, \$2.25
 Gold Bowl, 2.50

Coffee Spoon { Plain Bowl, \$1.25
 Gold Bowl, 2.50

USUAL DISCOUNT TO THE TRADE.

W. H. WILLIAMS & SON, Jewelers and Silversmiths,

Sole Manufacturers, 12 North Pearl St., Albany, N. Y.

HISTORICAL "CHARTER OAK" SOUVENIR.

THE HANDSOMEST OF THE SOUVENIR SPOONS.

EMBLEMATIC OF FREE GOVERNMENT.



ERNST SCHALL, Jeweler and Silversmith,

HARTFORD, CONN.

IT IS A FACT

that I keep the best assortment of BOSS and KEYSTONE CASES in the East.

If you do not have what you can sell, send to me, and I will send you a selection package. I also have on hand a large assortment of CHAINS AND CHARMS.

All mail or express orders promptly filled.

E. A. WHITNEY, 403 Washington Street, Boston, Mass.

TOWLE MFG. CO.,

MANUFACTURERS OF

Sterling Silverware

NEWBURYPORT, MASS.: 214 MERRIMACK ST.



CHICAGO:

149 & 151 STATE ST.

SAN FRANCISCO:

220 SUTTER ST.

THE LATEST PARISIAN NOVELTY.

GRAPE JEWELRY

MANUFACTURED BY
CROSSIN & TUCKER,
 400 Pine Street, Providence, R. I.

GENTLEMEN: This is my No. 6 holder. This holder has been on the market for the last 25 years, and sells just as well as ever.

The No. 7 is the same with a spring inside. These are standard goods, just as staple as cotton cloth.

The No. 5 is a cheaper hook and not quite so good, but it is a good seller. We sell more of these than any other.

The No. 25 is the most popular hook I have ever made, and covers the greatest variety of all. They are made in 9, 10 and 14-K. gold, plain, engraved, enameled and Etruscan.

Rolled Plate, plain and engraved, Coin Silver, bright polished, Oxidized and Old Silver. I put chain on all of these to match the holders.

The No. 25 in steel is the best cheap holder that has ever been put on the market, and the sales are increasing every season. I finish them in five ways—black, blue, bronze, nickel and silver-plate oxidized.

S. F. MERRITT,

Springfield, Mass



THE BLUE STAR DIAMOND SOLD—PURSES OF NET WORK SEEN EVERYWHERE—FASHIONS IN LIQUOR SERVICES.

PARIS, France, April 18.—The Blue Star diamond, which I mentioned in my last letter, has been purchased by Mess. Vever, the Rue de la Paix jewelers, who intend to send it, next Sunday, together with a great variety of jewelry, to the French Exposition, at Moscow. This rare stone has been exhibited, during the last few days, in a neat glass-case which occupies one side of a small room, at the back of the well-known little store. The daylight coming from the ceiling does not bring out to the best advantage the beauty of the curious gem. When I remarked this to one of the Vever brothers, he took the stone to the store, and placing it in a good light asked me to look at it full in the center; then I could see not only the purity of the stone, but also its decided blue color, hardly noticeable when examined sidewise. The Blue Star is valued at 500,000 francs. It is of an elegant shape, almost square with rounded angles, and weighs about 42 carats. The star is accompanied by four satellites of the same color, fashioned out of its cuttings, and which are worth together 250,000 francs. In the same glass case, I noticed a lovely pearl necklace, consisting of large white pearls alternating with black ones; a splendid diamond tiara, the design of which shows curling ornaments beautifully modeled; a stately fleur-de-lis made of diamonds and rubies, large sprays of roses, almond-tree flowers, anemones, etc.

Purses of fancy net-work with a varied texture, are seen everywhere. Some consist of gold, silver and platina tastefully interwoven, forming slanting bands, check-work, water-silk, etc. Several introduce, here and there, tiny gems of different colors, apparently sprinkling the work. The top, with a round neck, like that of a scent bottle, exhibits on the cover either a watch, or an engraved gem, a circular *motif* made of brilliants and turquoises or rubies. A few show a large moon-stone or a cats-eye.

Liquor services consisting of two decanters and twelve or more glasses are in white, blue or yellow glass, wrapped up in pierced gold or silver, with an addition of very small vari-colored stones. The handles exhibit either snakes or vine leaves, and stalks in the same metal also jeweled. The top part of the decanter generally has a curved cover over the mouth. This graceful part moves on hinges, and is connected with the neck wrapper. These articles are seldom cheap, being more difficult to execute satisfactorily than it would seem to a person who does not understand their workmanship.

ESTABLISHED 50 YEARS.
 RANDEL, BAREMORE & BILLINGS,
 IMPORTERS OF
DIAMONDS,
 AND OTHER PRECIOUS STONES.
 FINE PEARLS A SPECIALTY.

MANUFACTURERS OF
DIAMOND JEWELRY,
 IN THE LATEST DESIGNS.

Diamonds Recut in Modern Styles or Repaired on Premises.

58 Nassau Street,
 29 Maiden Lane,
 NEW YORK.

1 Tulp Straat,
 AMSTERDAM

1 St. Andrews St.,
 Holborn Circus,
 LONDON, E. C.

CHARLES H. PECKHAM,
DIAMONDS AND DIAMOND JEWELRY,

63 NASSAU STREET,
 Goods Sent on Memorandum. NEW YORK.



John A. Riley & Sloan Co.

860 Broadway, New York.

MAKERS OF

HAIR PINS, HAT PINS,

TIARAS, BROOCHES,

SCARF PINS, NECKLACES, ETC.

Rosaries & Crucifixes, Chatelaines.

Our line includes both 14k. Gold and Sterling Silver.

ARE YOU THINKING OF
GETTING UP A SOUVENIR SPOON?

I make a specialty of designing these spoons, and can give suggestions of my own or execute your ideas. **Souvenir Etching and Engraving.**

W. J. BRECKNELL, Designer and Engraver,
 SPRINGFIELD, MASS

OSTBY & BARTON,

SOLID GOLD BAND, STONE

-- AND FANCY RINGS --



—ALSO A LARGE LINE OF EMBLEM RINGS.—

WE DESIRE to call your attention to our large and varied assortment of

Complicated, High Grade Gentlemen's and Ladies'



In Gold Cases, both Plain and Enameled, in Choice Designs.

THE LARGEST STOCK EVER SHOWN IN THIS COUNTRY.

NON-MAGNETIC WATCH CO.

OF AMERICA.

CHAS. MCCULLOH, RECEIVER

177 Broadway. - - NEW YORK.

WATCH DIALS.

Any kind watch dial duplicated within ten days. Factories supplied with dials for their entire product or with special designs for their high grade movements. Special rates for large quantities. Emblems, photographs, landscapes and ornamental work of every description on plain, enamel or under glaze.

WALTHAM DIAL CO.,
WALTHAM, MASS.

A. RICKERT. C.A. STIEHLE.
RICKERT & STIEHLE,
MANUFACTURERS OF
GOLD CHAINS,
SWIVELS AND SPRING RINGS.
Chain Repairing a Specialty.
13 & 15 Franklin Street, NEWARK, N. J.



NEW YORK OFFICE.

PRESCOTT BUILDING,
ROOM 40 SAMPLES ONLY.

WORKS, BLACKSTONE & GAY STS.
TAKE PRAIRIE AVE CAR

Providence, R.I.

AIKIN, LAMBERT & Co.,

23 Maiden Lane,

NEW YORK,

Manufacturers and Exporters of

Fine Gold Pens, Pencils,

TOOTHPICKS, HOLDERS,

And Novelties in Silver, Pearl, &c.



THE BEST FOUNTAIN PENS.

New Assortments in SHOW CASES and FANCY TRAYS for JEWELERS. Price Lists and Catalogues for intending Purchasers.



Also American and Swiss Watches.

DIAMONDS, Loose and Mounted,

Gold and Silver Thimbles,

CHAINS and JEWELRY in New and Staple Patterns.

ESTABLISHED 1837.

TAYLOR & BROTHER,

OLD HOUSE READ, TAYLOR & CO.

IMPORTERS OF

DIAMONDS and PRECIOUS STONES,

CLOCKS and BRONZES,

860 Broadway, cor. 17th Street, N. Y.

Branch Office for Clocks and Bronzes,

1 1/2 MAIDEN LANE N. Y.

E. R. STOCKWELL,

19 John Street, New York.

All descriptions of

BADGES, * MEDALS, * PINS,

For Colleges, Schools and all Societies,

IN SILVER AND GOLD.

Jobbing and Repairing for the Trade.



✦ RUSSELL HOUSE, ✦
DETROIT, MICH.

Always a Favorite of the Jewelers, for the following (three) reasons:

1st—Excellence of its cuisine. 2d—Its central location to the trade they visit. 3d—Ample security its spacious vaults offer for samples and valuables.

CHITTENDEN & McCREARY, Prop'rs.

News Gleanings.

I. W. Cotton, Waldo, Fla., died recently.
 B. C. Ga-Nun, Carmel, N. Y., has assigned.
 C. Wade has moved from Newburgh, Ind.
 W. S. Hoke, Red Key, Ind., is out of business.
 B. Comings, Huntington, W. Va., has sold out.
 G. C. Hasslinger, Sikeston, Mo., is out of business.
 Isaac Davis, Linwood, Neb., has gone out of business.
 E. Judson has bought out F. W. Hancock, Lansing, Ia.
 J. W. Green, Fairfax, Vt., has sold out to Geo. Fullington.
 A. L. Fexer has succeeded Fexer & Barr, Cheboygan, Mich.
 H. H. Snively has succeeded S. Snively & Co., Elwood, Ind.
 C. B. Guth, Brookville, Pa., has moved into larger quarters.
 J. E. Tucker, Jr., Miles City, Mon., has sold out to R. A. Man.
 C. N. Reynolds, Dundas, N. Y., has sold out to E. Morley & Bro.
 Kelsey & Loomis, have succeeded J. O. Loomis, Union City, Pa.
 Dunn & Ellis have succeeded R. W. Dunn & Son, Jonesborough, Ark.
 Hart & Miller, Kirksville, Mo., have been succeeded by William Hart.
 Johnson Ater, Water Valley, Miss., has started a new jewelry store.
 Frank Stetson has bought out B. J. Alexander & Co., Weeping Water, Neb.
 A. P. Lansen has moved from Rush City, Minn., to Sacred Heart, same State.
 A. C. Ribnack has moved from Bloomer, Wis., to Kilbourn City, same State.
 A. Zimmerer, Nebraska City, Neb., has been succeeded by Fass & Weithoner.
 Baker & Worrell are the successors of Baker & McConahey, Washington, Pa.
 Schreider & Livengood have succeeded A. D. Schneider, Sewell Depot, W. Va.
 G. H. King, Monroe, Wis., died recently. Albert Miller is continuing the business.
 H. V. Johnson, Statesboro, Ga., recently lost \$400 by fire; there was no insurance.
 At Plattsburgh, Mo., R. C. Harvey and Powell Bros., have gone out of business.
 G. S. Greenleaf, Minneapolis, Minn., recently moved from 239 to 329 Nicollet Ave.
 Jacob Zimmerman has purchased Clinton Lytle's Silver Plating Works, Mifflinsburg, Pa.
 The Colorado Gold and Silver Mfg. Co., 1801 Blake St., Denver, Col., have gone out of business.
 At Temple, Tex., M. W. Branch is out of business and R. T. Crawford has been succeeded by Crawford & Cannon.
 Recently jewelers at Kalamazoo, Mich., were victimized by a swindler named Wm. J. Thorne, of jewelry worth \$400.

USE THE 
AMERICAN MAINSPRINGS
 FOR ALL KINDS OF AMERICAN WATCHES.
 [FACSIMILE OF WRAPPER.]

1 DOZ. MAINSPRINGS
18 S. E. O. S. 
 Extra Quality.
 TRADE  MARK.

THE BEST IN THE MARKET.

L. H. KELLER & CO.,
 Dealers in Fine Watch Materials and Tools.
 AGENTS FOR THE PATEK, PHILIPPE & CO. WATCHES.
 64 NASSAU STREET, NEW YORK.

DESIGNING **SOUVENIR SPOONS.**
 FOR

Suggestions given and Designs Executed.

CHARLES SELKIRK,
 31 N. Pearl Street, Albany, N. Y.



Fleur de Lis "VICTORIAS."

WE ARE SHOWING THE

Most Popular Line
 IN THE MARKET.

H. F. BARROWS & Co.,

1 1/2 Maiden Lane, N. Y.



No. 152.

"S"

A "NOVELTY" in Marquis Rings.

ASK YOUR JOBBER FOR

STERN BROTHERS' DIAMOND MOUNTINGS,

42 MAIDEN LANE, N. Y.

FACTORY,
 ST. IMIER, SUISSE.

HIPP DIDISHEIM,

83 NASSAU STREET,
 NEW YORK.

IMPORTER OF WATCHES,

SPECIALTIES:

The "Nassau," the best imported movement in the market, fitting all American cases.
 The "Mignon," the best Chatelaine Watch for the money.
 The "Gem," a high grade Chatelaine Watch with second hand, gold crown jewels in extra settings, etc.

If your jobber don't keep these goods, send to us and we will send you the address of one who does.

NEW * DUEBER

PATENT BASSINE

SOLID GOLD WATCH CASE.

MADE IN 14 KARAT RED GOLD ONLY.

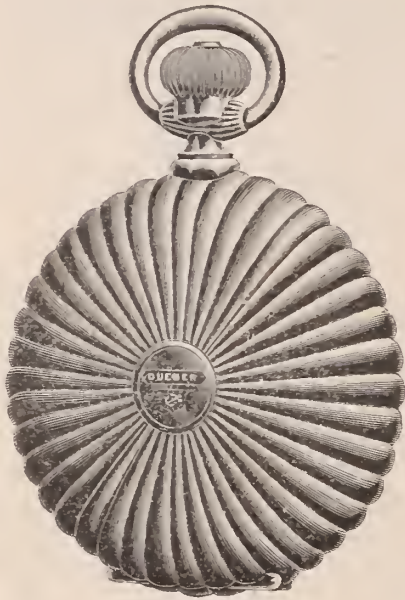

OPEN FACE AND HUNTING, 18-SIZE.

DESIGN No. 2,000,000.

The world-wide reputation of the famous DUEBER BASSINE SOLID GOLD WATCH CASE will be still further enhanced by the new and latest design as shown above.

It is a matter of record in the trade, that DUEBER WATCH CASES, by their superior finish and general excellence of workmanship, have for years been selected from the show cases of Watch Dealers, by buyers, *in preference to all others*; and in the manufacture of this DUEBER PATENT BASSINE SOLID GOLD CASE, all previous efforts in Watch Case making have been excelled, and the result is the handsomest, most artistic and perfectly constructed Watch Case ever made.

A hundred years from the time of purchase, after constant wear, its excellence will be fully as apparent as when bought.

Any one having the money to purchase one of these superb cases, will seek in vain for its equal in beauty, durability and intrinsic value.

This Case was specially designed for *Watch Case No. 2,000,000*, manufactured by THE DUEBER WATCH CASE MFG. CO. No first-class store is complete without it, as it will be selected by discriminating purchasers among hundreds of others.

This Case sold at net weight of Gold, making added. No charge for springs. Made in O. F. and Htg., 18-size—45 to 55 dwt.

THE DUEBER WATCH CASE MFG. CO., CANTON, OHIO.

A. J. GROENMAN & CO.,
DIAMOND CUTTERS,
 80 NASSAU ST., N. Y.
 WE MAKE A SPECIALTY OF SEL-
 LING FINE, SMALL MELEES.

T. B. BYNNER,
 Dealer in
Diamonds, Opals, Pearls,
 AND EVERY VARIETY OF PRECIOUS STONES,
 in varied and novel combinations.
 177 BROADWAY, NEW YORK.

ELGIN HOROLOGICAL SCHOOL
 ELGIN, ILL.

SEND FOR CIRCULAR.

Repairing for the trade.

Repair price list free.

BOOK * MARKS
 IN
STERLING SILVER,
 FRANK H. LA PIERRE.
 No. 18 East 14th St., New York.

H. M. SMITH & CO.,
 MANUFACTURERS OF
Gold Pens and Pencil Cases,

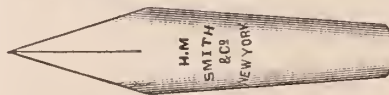

JOBBERS IN AMERICAN WATCHES.
 PLATED CHAINS.

Agents for Paul E. Wirt's Fountain Pen.

83 Nassau Street, New York City.

The American Watch Tool works, Waltham, Mass., were obliged to close last Monday on account of an accident to the boiler.

C. N. Jenks, who has been for some time with A. L. Benedict, jeweler, Lock Haven, Pa., has left for Booneville, N. Y., where he assumes the duties of deputy postmaster.

F. G. Wilson, Ithaca, N. Y., who recently assigned to J. H. Jennings, has been succeeded in business by Uri Clark, one of the common creditors with a claim of \$4,000 against him.

V. J. Fleichman, Waterloo, Ind., has invented a "gravity" clock, the hands of which are of wood, and may be taken off at any time without stopping the clock, and when replaced will adjust themselves automatically to show the true time.

H. J. Locke, jeweler, Belford, Me., recently purchased a clock which he believes is 135 years old. It was made by Riley Whiting, of Winchester, Conn. It is a noticeable fact that the wooden wheels which had grooved into each other for an unknown period, are apparently as good as ever.

A. W. Thoma, Ottumwa, Mich., has taken into partnership, his brother, W. E. Thoma, formerly of Thoma Bros., Kalamazoo, Mich., but latterly in business for himself at Jackson, Mich. The new partnership is known as Thoma Bros. W. E. Thoma has been in ill health since last December, and is now recuperating at Three Rivers, Mich.

It is reported that recently while Isaac Slocum was digging a well on the farm of George Beard, two miles east of Nevada, O., he struck his pick on a rough-looking stone about the size of an egg, which attracted his attention by its sparkling lustre. He has since had it examined by experts, who pronounce it to be a diamond. He refuses to sell the stone at any price. Mr. Beard has begun legal proceedings for possession of the stone, as it was found on his place.

L. A. Piaget & Co., Paterson, N. J., recently repaired a clock which not long since came to this country from Rochdale, England, and which is probably one of the oldest clocks to be found in the country. It is of the grandfather type, with solid mahogany case, beautifully inlaid. The face is of steel, finely engraved, the corners of which are overlaid with brass filigree work. The clock strikes every quarter hour on two bells, and at the hours of eight, twelve, four and six, plays a tune on a chime of bells. The monthly calendar and the moon's phases are also shown. The tunes played when striking the dinner hour are old "Winchester" and "Farnent," both popular tunes of the Scotch psalter nearly 250 years ago. The weights are held in place by steel chains, and every particle of the machinery has been made by hand. Experts in antiquities who have examined this time-piece pronounce it to be over 200 years old, with a probability of greater age. A record of its having been cleaned in 1723 is scratched with a pin on a portion of its mechanism.

O. E. Ashbrook, Winchester, Ky., is selling out.

J. H. Dunn, Cuthbert, Ga., has given a chattel mortgage for \$1,000.

August Hettel, 402 Morgan St., St. Louis, Mo., has gone out of business.

S. L. Wise, Greensburg, Pa., will soon occupy a new store on N. Main St.

Thomas Ruffin, Blue Mould, Tex., has given a chattel mortgage for \$350.

A chattel mortgage for \$1,135 has been given by F. M. Huston, Ponca, Neb.

A judgment for \$600 has been issued against C. F. Reitling, Carlisle, Pa.

A chattel mortgage for \$7,500 has been given by J. S. Taylor, Smithfield, N. C.

A judgment for \$312 has been entered against G. G. Castle, Buffalo, N. Y.

Mr. Baker, Corsicana, Tex., was last week robbed of \$150 worth of silver watches and chains.

Andrew Jackson, Duluth, Minn., is still disposing of his stock at auction, with the intention of retiring from business.

O. B. Carr, Kokomo, Ind., while examining a tightly-coiled spring, accidentally unloosened it, and was blinded in one eye.

S. S. Hayden, who was recently admitted into partnership in the C. S. Saxton Co., Springfield, Mass., has purchased a handsome dwelling.

Faulkner, Kellam & Moore, Atlanta, Ga., have established a department for grinding and repairing mathematical instruments, microscopes, spy-glasses and telescopes.

An eight-year-old daughter of S. E. Sanborn, Minneapolis, Minn., had a leg broken Sunday evening. The Sanborn family carriage was run into by a carelessly-driven horse.

Goldman & Wiggenhorn, 287 Reed St., Milwaukee, Wis., have dissolved. Mr. Goldman will start a jewelry store at 281 Reed St., and Mr. Wiggenhorn will remain at the old number.

James Boneyson, a desperate colored burglar, was arrested last Thursday morning while walking down High St., close to J. & I. Kleeman's store, Columbus, O., which he burglarized some days ago.

Dan Turpin, alias Eddie Turpin, was arrested, last week, at New Orleans, La, charged with being a dangerous and suspicious character. Turpin is an old offender, his scheme being the selling of bogus jewelry.

A few days ago a slight blaze called the fire department to the works of the Columbus Watch Co., Columbus, O. The fire originated from an overheated chimney stack. The roof took fire and was not extinguished until it was entirely burned.

Fred Rubin, So. Pittsburgh, Tenn., died recently a most horrible death from the effects of swallowing nitric acid. He had been in the habit of going on a big spree every few weeks for several years, and had been on one of these for several days previous. He leaves a wife and three sons. He was a German and was sixty-three years old.

Last week a stranger entered the store of Albert Kamp, Sing Sing, N. Y., and bought a diamond ring valued at \$26, giving a check for \$30 on the First National Bank of Yonkers, N. Y., signed by W. B. Miller. The check was subsequently learned to be worthless. The swindler is about 35 years of age, is about 5 feet 6 inches tall, and has sandy hair and moustache.

William Scott, alias Ashby Stuart, a negro, went into the jewelry store of William Campbell, Richmond, Va., last Monday, and asked to see a watch. A watch and chain were shown him, and Scott put them on. In an instant he darted for the door and ran down the street at a rapid gait. He was captured and locked up in the station house. On Tuesday morning the mayor gave him sixty days in jail.

Miss Ruth Greenleaf, elder daughter of Damon Greenleaf, of Greenleaf & Crosby, Jacksonville, Fla., was married on April 23 to J. H. Douglass, of that city. The ceremony took place in St. John's Church. The benediction was pronounced by Rt. Rev. E. G. Weed, bishop of the diocese of Florida. The church was filled with the fashionable people of Jacksonville, and a brilliant reception was afterward held at the home of the bride's parents. Dr. and Mrs. Douglass left the following morning for a bridal tour through the North, and will later in the season sail for Europe to remain a year.

The show window of William Mauch's store, 1436 S. Broadway, St. Louis, Mo., was broken into late last Tuesday night by some unknown persons, and a lot of gold ear-rings and eye-glasses valued at \$75 were stolen. Several hours later John Hogan was arrested. When searched seven pairs of ear-rings were found on him, together with a lot of eye-glasses. After being closely questioned he confessed the theft, but refused to say who his partner was. About

The "CLEOPATRA"

PATENT APPLIED FOR.

A NOVELTY IN SOUVENIR SPOONS,

In keeping with the latest fad.

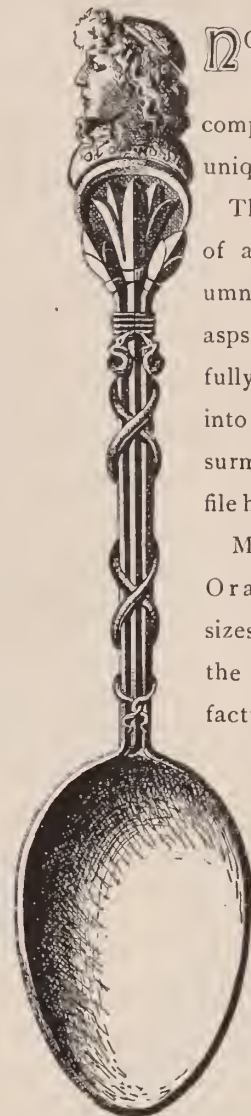

NO stock of Souvenir Spoons complete without this unique design.

The handle consists of an Egyptian column encircled by two asp, the top gracefully branching out into the lotus flower, surmounted by a profile head of Cleopatra.

Made in Tea, Orange and Sugar sizes. In addition to the above, we manufacture a large variety of Souvenir Spoons, applicable to various localities, photos and prices of which will be furnished on application.

ALVIN MFG. CO.

860 Broadway,
NEW YORK.

Factory, 24 Boudinot St., Newark, N. J.

BOOKS FOR JEWELERS.

W. B. DICKIE,

67 William Street, New York,

PUBLISHER OF

Improved Watch Stock Book

—AND—

Improved Watch Repair Book.

SEND FOR DESCRIPTIVE CIRCULAR.

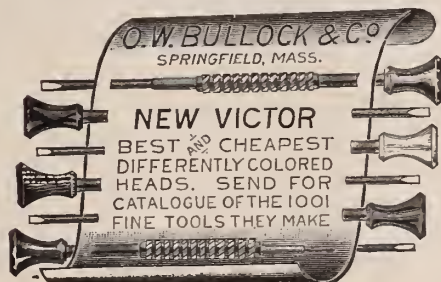

HENRY TROEMNER,
No. 710 Market Street, PHILADELPHIA.

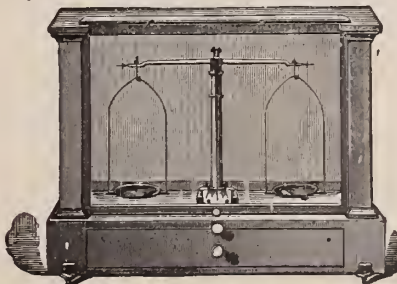

Manufacturer of FINE GOLD SCALES and DIAMOND SCALES
Bullion Balances and Weights, in use at all the U. S. Mints and Assay Offices. Priced Catalogue on application.

noon the following day John Clark was arrested, on suspicion of being the second party, and when searched a pair of ear-rings were found in the lining of his hat.

E. B. McClelland, Syracuse, N. Y., is in New York on business.

F. L. Davies & Bro., Nashville, Tenn., have been having an auction.

G. C. Wilkins, Syracuse, N. Y., has returned from a trip to the Metropolis.

Mr. Carr, of the Stief Jewelry Co., Nashville, Tenn., has returned from a trip East.

The stock of goods of F. S. Neff, Nashua, N. H., were attached for \$3,205 by Boston parties last week.

Jos. Seymour Sons & Co., Syracuse, N. Y. have a magnificent display in one window of the Norwegian silver for which they have been appointed agents.

Shortly before 11 o'clock of last Tuesday night an officer found the door unlocked of J. A. Daller's store, Jackson, Mich. The safe was also open. Mr. Daller was notified but on his arrival found that nothing had been disturbed.

F. C. Cole, who, while employed by R. J. F. Roehm & Son, Detroit, Mich., about March 1, stole a quantity of jewelry, was convicted in the Recorder's Court last Tuesday, and sentenced to five years in the house of correction.

The Hustings Court at Petersburg, Va., last Thursday was engaged in the trial of the case against C. E. Hall, charged with attempting to break into the store of J. W. Young. The jury returned a verdict of "not guilty," and the accused was discharged.

The embarrassment of J. A. Kuschke, 88 Public Sq., Wilkesbarre, Pa., whose store was closed last week by the sheriff, on executions for \$2,289.50, issued by C. A. Kuschke, is said to be only temporary, and it is to be hoped that he will soon be able to reopen.

The home of C. A. Dolley, a jeweler of Port Allegany, N. Y., was entered by burglars a few nights ago. About \$200 in money was stolen together with the keys to his store. The thieves removed \$700 worth of jewelry therefrom and decamped, leaving no trace of their identity.

Has Been Stopped Victimizing Jewelers Temporarily.

One of the most successful thieves who have victimized wholesale jewelers of New York for some years past, was arrested last week, through the efforts of a jeweler whom he had attempted to victimize. The man visited jewelers in Maiden Lane and John St., and represented himself variously as being connected with Spencer & Co., of Norwalk, Conn., and J. C. Demmert, Trenton, N. J. He entered the office of Hodenpyl & Sons, and claimed that he was the nephew of the first-named jeweler. He selected several pieces of jewelry expecting to receive them with the bill, as is the usual procedure. The firm, however, were suspicious of the fellow, and stated that they would send the jewelry by express to Spencer & Co.

He tried the same trick upon Keller & Untermeyer, J. B. Bowden & Co., Peterson & Royce and Carter, Sloan & Co. The police were notified of his presence in the trade, but detectives who were detailed to arrest him, failed to do so. In the last issue of THE CIRCULAR, a very good description of the fellow was published, and the trade was on the alert.

Last Wednesday evening A. J. G. Hodenpyl met the man on William St. and approaching him asked him why he had not called again at the office as he had promised. Assuming an indignant look, the thief said his name was Mr. Phillips, and that he had just come from Newark, N. J. Mr. Hodenpyl begged his pardon and left him. He, however, kept the fellow in sight and when he met a policeman told the latter to arrest "Mr. Phillips." When the latter saw the officer coming he dodged into the John St. entrance of the building 192 Broadway which has two entrances. No doubt thinking that Mr. Hodenpyl and the officer would both rush to the other entrance, he waited a moment and then came out of the door he had entered only to walk into the arms of the policeman who had sent Mr. Hodenpyl to the other doorway and waited himself.

When taken to the Old Slip Station he gave the name of James Martin, and his home as Cleveland, O. On Thursday evening the police requested all the jewelers whom Mar-

tin had visited to identify him at the station. Martin was placed in a line with six other men and besides being immediately identified by representatives of the firm already mentioned he was picked out by Mr. Knapp, of Smith & Knapp, as the man who had obtained goods from his firm a month ago. A clerk of Sidney T. White also recognized him as a man who had obtained about \$400 worth of goods from the firm. Other victims who were represented were W. M. Fisher, Tiffany & Co., Aikin, Lambert & Co., and O. R. Worm.

On Friday morning, Martin was taken to the Tombs Police Court and remanded for trial.

THE UNITED STATES WATCH CO., WALTHAM, MASS.

Carry in stock a full line of their celebrated 6 size Ladies' watch, in nickel and gilt, 7, 11, 15 and 16 jewels, from plain to fully adjusted.



Also a complete line of 18-size Hunting and 16-size Open Face all grades, in nickel and gilt. The reputation of the United States Watches is too thoroughly established to require statement here—they excel in finish and time-keeping qualities those of any other make. Our factory at Waltham, Mass., is the model in automatic machinery and tool equipment. When you want a timepiece call for the United States Watch. On sale by all non-association jobbers, to whom retailers should apply for a complete line of these watches as they give less trouble and more satisfaction than any other. Address all communications to THE UNITED STATES WATCH CO., Waltham, Mass.

N. Y. Office, 53 Maiden Lane, F. S. Baker, Agt

THE MILES MORGAN HISTORIC SPOON.



and armed with muskets started for Beverly. On the arrival of the party at Beverly the marriage was duly celebrated: the bridegroom and his friends then loaded the old pack horse with the bride's "household stuff," shouldered their muskets and escorted the bride, who walked with them the whole distance, one hundred and twenty miles, from Beverly to Springfield. Considering the fact that at that period there were no roads across the country, and that the route would take them through forests and swamps, and across rivers without bridges, it will be readily understood that this wedding tour must have occupied a good deal of time, and have been attended with serious difficulties and dangers. But the men and women of that day were brave and hardy, and accustomed to endure hardship and to face dangers. Miles Morgan was one who was ready to brave danger. When Springfield was attacked by Indians, Oct., 1675, he was first and foremost in defending their homes. In Morgan's house a number of people had taken refuge, a desperate attempt was made upon the dwelling of the dreaded veteran and his sons by the Indians, but all advances were met with such cool intrepidity and deadly aim from every window and loop hole by these practiced marksmen, the astounded savages were forced to retire, leaving members of their foremost warriors dead upon the field, whose bodies they dared not attempt to recover from under the sure aim of the fatal blunderbuss.

The figure upon the spoon represents Miles Morgan starting out for his daily toil in the field, with hoe in hand and blunderbuss upon his shoulder to protect himself from the red man. It is quite fitting that his descendants should perpetuate his memory by erecting a statue upon one of the public parks of Springfield as they have done, and that a correct representation of the statue should be stamped upon silver that is as sterling in quality as was the man whom it represents.

L. S. STOWE & CO., Springfield, Mass.

Who was Miles Morgan that his statue should be stamped upon Silver? He was of Welsh origin, born in 1615. He sailed from Bristol, England, with his two older brothers, and arrived in Boston in April, 1636, and settled in Springfield about 1643, being one of its early settlers. Soon after coming to Springfield, he married Prudence Gilbert of Beverly, Mass. Tradition tells us he took with him two friends and an Indian, with an old horse to convey the household stuff of the bride.

The Alliance Takes the Case in Hand.

NORWALK, Conn., April 27.—The Jewelers' Security Alliance decided to take in hand the burglary of Legrand Jackson's store, and have their detectives work on the case. Mr. Jackson, though not a member of the Alliance, is well thought of by the leading wholesale jewelry houses, and it is through their efforts that the matter has been taken in hand. The fact that the Alliance are after the burglars is a source of much comfort to Mr. Jackson, as he knows their efforts in tracing stolen jewelry have always been crowned with success. Chief DeForest of this city has received letters from Boston, Mass., containing photographs and descriptions of the crooks who are working in this locality, and one of them is recognized by several Norwalk people, although they cannot exactly tell the time or place they have seen him.

A Female Jeweler Who Can Shoot.

WICHITA, Kan., April 23.—About 1 o'clock this morning, Mrs. A. Sommers, a widow, was awakened by a noise in her young son's room. Quietly peeping in she espied two burglars, rope in hand, leaning over the boy and threatening to hang him if he didn't tell them where his mother kept her valuables. Mrs. Sommers retreated and awoke Agnes Sommers, who keeps a jewelry store at 400 E. Douglas Ave., and the latter, arming herself

with a .45-caliber Colt revolver, boldly marched in on the burglars, telling them to clear out or she would shoot. The men stood their ground until a ball went whizzing past their heads and struck the wall behind, when they sprang through a back door, followed by a parting shot that, from the screams of pain that escaped one of the men, must have hit its mark. The house is in the outskirts of the city and the burglars easily escaped.

The McBride-Marcellus Embroglio—L. M. Sigler Elected Trustee.

CLEVELAND, O., April 27.—D. H. McBride having returned from New York and the East, the hearing in the examination to discover assets belonging to the McBride & Marcellus Co. was resumed in the Probate Court Friday morning, McBride being the first called to the stand.

McBride's first admission of any account was that he himself had erased the credit on the book of a \$5,000 note commonly known as the Durbin note, and had credited it to Penfield, and it had afterward been included in the judgment note given to Penfield. He alleged, however, that Penfield and Seiberling had indorsed the note and the corporation had had the benefit of the money.

McBride was asked by Attorney Dellenbaugh if he had not taken certain goods of value out of the Akron store before the receiver took possession. He replied that on the Monday morning he had received

telephonic information and instructions to turn over a quantity of goods to Mr. Penfield's attorney, Mr. Cobbs, of Akron. On receiving this word in Akron at dead of night, McBride got out of bed, opened the store on S. Howard St., at 4 o'clock in the morning and packed \$7,800 worth of watches and diamonds in a grip to turn over to Penfield at 10 per cent. discount.

McBride further stated that several days before the failure it had been agreed with Marcellus' knowledge, that if necessary Penfield and the corporation attorneys should be protected with stock. He explained the transactions by which the company gave Mr. Penfield a note for \$15,000 payable in one year.

The struggle over the election of a trustee for the company began in the Probate Court on Saturday morning. The fight was narrowed down to O. J. Campbell and L. M. Sigler, the present trustee, who was appointed temporarily by the Probate Court to succeed James Gibbons when the last named resigned.

The attorneys who held claims congregated in the record room of the Probate Court, and effected an organization by electing W. C. McFarland as President, and C. C. Young as Secretary. McBride and Marcellus were both present.

When the meeting finally adjourned, Mr. Sigler was virtually elected. Prior to the election he set aside \$7,020 of the preferences

COLUMBUS WATCH CO.,



No. 97. Open Face.

Discontinues

Movements

Nos. 27 AND 97.



No. 27. Hunting.

THESE are full Jeweled with extra large Center Jewel. Finely adjusted and just the thing for railway service. There are only a few of these movements on hand, and as they will be sold at a price that will move them QUICKLY, ask your jobber for them in time.

COLUMBUS WATCH CO.,

COLUMBUS, OHIO.

Canada and the Provinces.

A. R. Harmon, Montreal, P. Q., is on a few days' trip to Boston and New York.

Davidson Bros., Vancouver and Victoria, B. C., have opened a branch at New Westminster, B. C.

J. M. Warner, formerly with the firm of Schwob Bros., Montreal, P. Q., is now connected with the Montreal Optical Co.

Auction sales are being carried on at Richard Helmsley's store, Montreal, P. Q., prior to moving.

J. L. Eaves, Montreal, P. Q., on the 23d left that city for New York and Providence to select another supply of goods for his firm.

C. H. A. Grant, of the Montreal Watch Case Co., and Schwob Bros., Montreal P. Q., has just returned from a three weeks' tour through Ontario.

William Eaves, Montreal, P. Q., has been confined to his bed for some time through sickness. He caught a severe cold while on his last trip to New York.

M. L. Green, London, Ont., has formed a partnership with Mrs. G. W. Pitt, of that place. Mrs. Pitt is the wife of a jeweler doing business at 191 Dundas St.

The Winnipeg Jewelry Co. (formerly W. F. Dole), Winnipeg, Man., have been admitted into the Canadian Association of Jobbers in American Watches.

J. L. Eaves, of Montreal, who, as stated in

this paper recently, has dropped the retail and entered the wholesale jewelry business, has just secured a valuable associate in his labors in the person of J. G. Monk. The latter has been for many years the manager for Louis Davis & Co., with whom he acquired an extended and varied experience in the jewelry business.

D. W. Rowland, one of the pioneer Baptist ministers of Canada, died in St. Thomas, Ont., last week, at the advanced age of 83 years. Fifty years ago he came to New York, then to Delhi, Ont., and forty-five years ago to St. Thomas, engaging in the jewelry business. In 1855 he entered the ministry of the Baptist Church, and has been a most active worker ever since.

Billy Lawlor, a Hamilton, Ont., man who eight years ago, was sentenced to ten years in the Kingston Penitentiary for being implicated in the Simcoe jewelry robbery, will be pardoned. About \$14,000 worth of jewelry was stolen, but through the evidence given by Lawlor, the greater part of it was recovered. Lawlor recently went insane and was sent to Rockwood Asylum. He will be released when his friends decide where he is to be taken.

The detectives at Toronto, Ont., believe they have under arrest the most successful thief that has visited that city in many years. His name is John Nearriem, alias John Miller, alias Kruptz, and he is wanted in Rochester and Buffalo N. Y., and other cities in the States. He was arrested in

company with a woman who was also taken in custody. The pair claim to be husband and wife, and the man says he is a New York jeweler.

Ed. Collins, Wm. Mackay and Samuel Watson, who were arrested in Montreal, P. Q., last week on the charge of robbing a jewelry store at Cobourg, Ont., pleaded not guilty. Their trial was put off until Thursday, so as to give the jeweler, who was robbed to the amount of \$600, a chance to arrive and identify, if possible, the jewelry that was found upon them at the time of their arrest. The first two prisoners were subsequently taken to stand their trial at Cobourg, the other being released.

Maine's Gift to Her Namesake.

AUGUSTA, Me., April 24.—The Maine Legislature recently voted to buy a set of silver plate for \$1,000, to be presented to the cruiser *Maine*, as a token of appreciation of the honor of having one of the big cruisers of the new Navy named after the Sunrise State.

Colonel C. H. Osgood, of Lewiston, this State, has just received designs for the proposed plate, which he submitted to the Governor and Council at their meeting today. The designs show a tureen and side dishes to be made of coin silver. The escutcheon of Maine is emblazoned on the body of the dishes, the covers and sides being amply significant of Maine's pine cones.

SOUVENIR SPOONS

IN ∴ COFFEE, ∴ ORANGE ∴ AND ∴ TEAS.

The accompanying Cuts represent a few of the many patterns we are making for the Trade in Sterling Silver only.

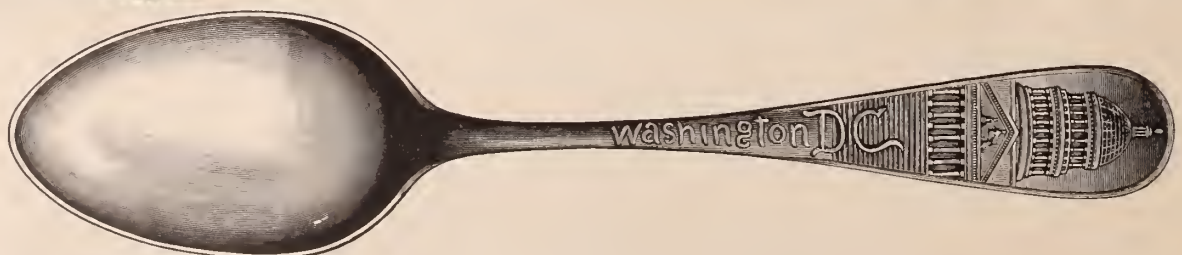

New York Office,

25 East 17th Street.

Frank M. Whiting & Co.,

Address all Communications to North Attleboro, Mass.

NORTH ATTLEBORO, MASS.

Providence.

W. F. Maine, Iowa City, Ia., was in town last week.

E. L. Dunn has moved from 67 Friendship St. to 178 Eddy St.

H. S. Tanner has discharged a chattel mortgage of \$3,000.

F. A. Miner will move, about May 1st, from 14 Page St. to 67 Friendship St.

G. M. Luther has started in business at 25 Calendar St., as the City Pearl Works.

F. V. Kennon has returned from a Western trip with J. T. Mauran's line of samples.

Arthur & Co., 33 Eddy St., have issued a very fine catalogue of their latest samples.

B. E. Daggett and family have gone to their cottage at Shawomet Beach for the summer.

The stock, tools and fixtures of the late Charles Downs were sold at public auction on the 27th.

John Austin and family have moved into their summer residence at Pawtuxet Neck for the season.

Charles Fletcher has been elected 5th Sergeant, and Isaac Giddings, 1st Corporal, of Co. D., First Light Infantry.

B. A. Ballou has been elected a member of the Select Committee of the Society of Mechanics and Manufacturers.

M. V. Brady started West for Hearn & Braitsch recently but was taken sick in Detroit, Mich., and obliged to return.

J. A. Foster, of J. A. Foster & Co., will start on his annual European trip May 12, and will be absent about three months.

R. G. Schutz has returned from an extended and successful Southern and Western trip for Hamilton & Hamilton, Jr.

H. A. Kirby, of Kirby, Mowry & Co., has arrived in Europe where he will remain for several weeks in the interest of his firm.

W. T. Luther, foreman for W. E. White & Co., has the sympathy of a host of friends, in the death of his wife on the 16th inst.

Holden & Knox are to enlarge their facilities at 14 Page St. by occupying the entire second floor, a portion of which they now occupy.

Daniel Burke, 66 years, who had been in the employ of Thornton Bros., for several years dropped dead on an Elmwood horse car last Tuesday from heart failure.

The firm of Taylor & Cole, 14 Page St., has been dissolved by the withdrawal of J. C. Taylor. Mr. Cole will continue the business at 67 Friendship St., taking the shop vacated by E. L. Dunn.

S. H. Bailey, of Foster & Bailey, has been elected a delegate to the International Convention of the Young Men's Christian Association to be held May 9, at Kansas City, Mo.

W. K. Logee, who has purchased an interest in the firm of A. S. Southwick & Co., will represent the house on the road and at-

tend to the office duties while Mr. Southwick attends to the management of the shop.

Hagan, Fuller & Co. are arranging to move from 363 Eddy St. to the shop formerly occupied by J. C. Harrington & Son, 129 Eddy St. They expect to move soon after May 1st, on which date the latter firm will close out their business.

Mrs. Mary F. S. Smith has been appointed administratrix on the estate of her late husband, A. J. Smith, formerly of Mackinney, Smith & Co.; bond, \$20,000. Mrs. Smith was also appointed guardian of three minor children; bond, \$4,000 in each case.

H. S. Tanner has been elected captain of Co. A., First Light Infantry Regiment of this city. After the election the members of the command adjourned to Capt. Tanner's pleasant residence on Adelaide Ave., and were royally entertained at supper.

Owing to trouble, as stated in THE CIRCULAR several weeks ago, the firm of Towne & Ingraham has dissolved, E. B. Ingraham having withdrawn and started in business at 127 Sumner St., while L. Towne continues at 94 Point St., under the style of L. Towne & Co.

As the item published last week in this department regarding the transfer of property by Kent & Stanley to the Kent & Stanley Co. may be misleading, it may be well to say that all the property of the former concern has been transferred to the latter corporation. add Cleveland

Sol. Bergman & Co., Omaha, Neb., is being sued for \$241.

OLD CITY GATE SOUVENIR SPOON.

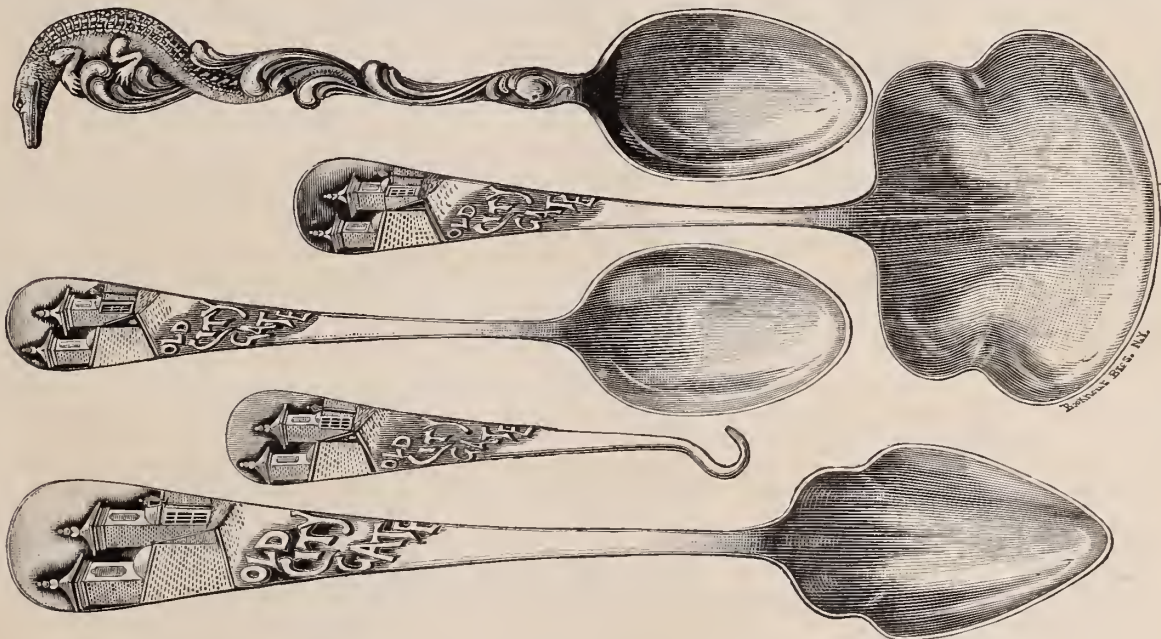

This gate was in the wall that formerly surrounded the City of St. Augustine, and is the principal historic feature of the City and was built in the 16th Century.

NO COLLECTION OF SOUVENIR SPOONS COMPLETE WITHOUT IT.
 FOR SALE ONLY BY
GREENLEAF & CROSBY, Jacksonville & St. Augustine, Florida.

Chicago.

L. C. Krueger has sold out his business at 312 E. North Ave., to L. A. Antoine.

Mr. Platt, of Foster & Bailey, Providence, R. I., is in town in the interest of his firm.

The Manson Jewelry Mfg. Co., recently filed a certificate of increase of capital stock from \$5,000 to \$50,000.

Mr. Alister, of B. F. Norris, Alister & Co., who has been in California since March, is expected in Chicago early in May.

G. W. Fairchild, F. A. Frey, F. A. Jeanne, and E. L. Brown, travelers from New York, were at the Wellington Hotel last week.

A. L. Smith, president of the Geneva Optical Co., was last week called to Belding, Mich., to attend the funeral of his brother.

F. H. Jacobson, special watch case Manufacturer, will move May 1 from 328 Dearborn St. to 96 State St., in the Lapp & Flershem Building.

C. J. Olin, Piqua, O., secretary of the United States Jewelers' Guide, was in town last week and arranged for the May meeting of the Guild at the Saratoga Hotel.

C. D. Peacock, the well-known retail jeweler, who has been to Hot Springs, Ark., during the last three weeks for the benefit of his health, has returned much improved.

The engagement of Russell Spaulding, son of H. A. Spaulding, of Spaulding & Co., and Miss Ella Drury, of St. Louis, has been announced. The marriage will take place early in the fall.

The five young men arrested some weeks ago charged with robbing the firms of J. H. Purdy & Co., and Lapp & Flershem have been released and the cases against them stricken from the docket.

The Secretary of State last week issued a license of incorporation to the Garden City Watch Co., of Chicago, to deal in watches and jewelry; capital stock, \$10,000; incorporators, G. T. Fox, W. A. Fulton, and F. A. Moore.

C. H. Knights, of the firm of C. H. Knights & Co., has been confined to his home for some days owing to blood poisoning caused by the dyes used in silk stockings. He is improving, however, and expects to be out in a few days.

A. W. Engel, 115 Dearborn St., proprietor and manufacturer of Engel's patent ring gauge, has just resumed business after several weeks absence. Mr. Engel had a severe tussle with typhoid fever but conquered his assailant, and although still weak and peaked in appearance he is able to receive the congratulations of his friends.

Charles Barclay, the jeweler of Lead City, in the Black Hills, S. Dak. and his family passed through this city last week en route to the Lake Superior country for the benefit of the health of Mrs. Barclay's mother. The change of air and scene was unavailing, however, and the patient died soon after arrival in that section.

Auctioneer P. J. Burroughs has been in town taking a few days' rest. He stopped at

the Clifton House. His latest triumph in his line was at Sheboygan, Wis., where he made a very successful sale. He leaves now for Brookfield, Mo., and from there he goes to Atchison, Kan. In the fall Mr. Burroughs has an engagement in New York City. He is a very busy man.

Among the buyers in town last week were Mr. Sommer, of Sommer & Pierik, Springfield, Ill.; G. W. Tallman, Lanark, Ill.; Henry Plumb, Des Moines, Ia.; W. T. Brewer, Bedford, Ind.; C. H. Conner, Aurora, Ill.; C. Christianson, Stoughton, Wis.; E. T. Mudge, Homer, Ill.; Frank Foote, Lake Mills, Wis.; M. N. Berg, Cloquet, Minn.; G. S. Goldstone, Davenport, Ia.; J. Q. A. Sheldon, Manhattan, Kan.; E. J. Cain, Lodi, Wis.

Trade is reported quiet by most dealers, though some say they have nothing to complain of. In addition to the customary dullness of the season, the backward spring and the generally disagreeable weather have combined to cause a slackness in business; but a continuation of the recent sunshine will cause a boom in the trade and dealers are confident of an improved state of things in the near future. Incoming traveling men report a fairly good business.

The question of early closing is again being agitated. Its advocates desire the business day during the summer to begin at 8.30 and end at 5.30, instead of 8 and 6, as at present. They argue that practically no business is done the first and last half hours of the day, and as the employees during the busy season frequently have to work until late at night, it is no more than right, when business is slack, that the help should be given a shorter day. The movement has many friends, but it has opponents as well, and the latter being composed of employers, are likely to have weight in the settlement of the question. A similar agitation was begun a year ago, but nothing came of it.

Moving day in Chicago as in New York is at hand, and those who will seek new quarters on May 1 are making preparations to migrate. The dating of many leases, both business and residence, from the first of May causes an annual tearing up in which apparently the whole city takes part. Renting agents for a number of years have sought to have more of their leases expire Sept. 1, and thus divide the removals between the spring and fall. Their labors in a measure have been successful, but May 1 will doubtless continue to be known as moving day for many years to come. Taken on a whole there will be numerous business removals, but among jewelry firms there will be few changes. C. F. Happel & Co., who have been at 126 Dearborn St. for many years, will soon be in their new rooms at 88 State St., where they will be better prepared to handle their rapidly-increasing business. Spaulding & Co., are very busy with the work of preparing for their new store on State St., which they expect to occupy June 15. They have elegant quarters at present, but after removal they will be better situated than ever.

Boston.

A. Selman, of the American Watch Co.'s New York office, was in town last week.

O. A. Drinkwater, of Morrill Bros. & Co., has returned from his southern outing.

Treasurer E. C. Hammer, of the United States Watch Co., Waltham, has been quite ill.

C. F. Morrill, of the Bay State Watch Case Co., is receiving congratulations on the birth of a daughter.

Buyers in town recently were W. L. Kelley, New Bedford, and G. H. Whittemore, Milford, this State.

Dean Southworth, of D. C. Percival & Co., and a number of the salesmen have been home sick during the past week.

The display windows and remodeled front of C. D. Place's new location on Washington St. are among the most attractive in the city.

W. F. Nye, New Bedford, this State, stopped over in this city last week, previous to his departure for the Pacific coast on a pleasure trip.

Benjamin Shreve and Mr. Low, of Shreve, Crump & Low, were ill with the prevailing influenza, and absent from business for several days last week.

A. Stowell & Co. display upwards of fifty different patterns of souvenir spoons in their show window. They are the admiration of hundreds of devotees of the fad daily.

Shreve, Crump & Low's new building at the corner of West and Tremont Sts. is nearly completed, and the company hope to take possession by the middle of May.

Kattelle Bros. last week suffered a slight loss from the fire in the upper stories of the building occupied by them, 95 Court St., the principal damage being occasioned by water.

L. J. Eaves, Montreal, P. Q. son of the late Edmund Eaves, and successor to his business, has been here during the week, and made a flying visit to the American Watch Co.'s factory at Waltham.

Two of the handsomest sleeve buttons in the city are in the possession of C. W. Beals. Four superior diamonds of the blue Brazilian type, perfectly matched, and all cut to the same size, have been mounted in each handsome button of gold open work.

Traveling men in town last week were: Col. Stevens, of the Brooklyn Watch Case Co., Louis De Goll, of the Roy Watch Case Co.; and G. B. Osborne, New York; J. L. Sweet, of R. F. Simmons & Co., Attleboro Falls, Mass.; Mr. Thresher, of Waite, Thresher & Co., Providence, R. I.; and T. G. Frothingham, North Attleboro, Mass.

New Orleans.

The jewelry business of Judah Hart, which has heretofore occupied the two stores, 48 St. Charles St. and 198 Common St., has been concentrated in the latter location.

A notable feature of the window display in A. M. Hill's store this week is a superbly

carved meerschaum pipe, which won the first prize at the Paris Exposition in 1889. The pipe was purchased in France by a wealthy Central American, who is its present possessor.

A. B. Griswold & Co. are offering for sale all of the fixtures in their store, 119 Canal St. The fixtures will be replaced by an entirely new outfit of elegant design.

Another store has been added to A. M. Hill's establishment, 115 Canal St. Material improvements in the establishment will be made during the summer.

Connecticut.

E. F. Gordon, New Hartford, has moved to North Carolina.

J. J. Miskell recently moved from Waterbury to Suffield.

F. A. Shepard, formerly of Waterbury, is now located at Torrington.

R. N. Johnquest & Co., Ansonia, have provided class rings for the class of '91, Ansonia High School.

J. G. Griswold, Meriden, is making an elegant display of clocks just added to his stock of goods.

Very fine specimens of art embroidery are exhibited in the windows of E. J. Pierpont's store, Naugatuck.

J. H. Caruss, optician, who has been at Hustace & Anderson's, New London, the past week, opens this week in Norwich.

Chris. Strobel, of Lake, Strobel & Co., Waterbury, was last week appointed administrator on the estate of the late C. H. Adams.

A new structure for office purposes for the Aluminum Brass & Bronze Co., Bridgeport, is now in course of erection near the site of their works on Housatonic Ave.

H. B. Hoyt, South Norwalk, injured his arm and hand recently by cutting them on the glass of his show window, which he fell through while engaged in fixing his awning.

J. T. Bates has opened a salesroom at 823 Chapel St., New Haven, for the sale of watches on the one dollar a week instalment plan. He has agents in his employ who canvass the city.

Work will be begun in a day or two for the erection of the new W. L. Gilbert school, in Winsted, which will cost \$100,000. The late Mr. Gilbert, the noted clock manufacturer, left \$700,000 to found and maintain this school.

Esoofally Hipotoola, a dealer in clocks in Calcutta, India, was the guest of the E. Ingraham Clock Co., Bristol, on Wednesday, and was shown through the extensive works. His rich Oriental costume of white silk attracted much attention, although out of doors a long English ulster was worn over it.

G. L. Streeter, New Haven, is preparing to move to Fredericksburg, Va., to engage in the jewelry business there, having embraced a good opportunity to buy out a well established business there, the proprietor of which, J. M. Chappell, sells out, having fallen heir

to property and desiring to retire from active business. Mr. Streeter closes his business in New Haven May 1. He has been in the jewelry business in New Haven for twenty-five years. His watch and jewelry repairer, F. O. Foster, who has been with him for fifteen years, goes with Mr. Streeter to his new store.

Utica.

A. Jay Cross, optician, New York, was at C. H. Schiller's last week.

C. H. Schiller has been elected a member of the Fort Schuyler Rifle Association.

A. J. McCall, optician, has sold his establishment at 242 Genesee St. to M. E. Kenney.

Clarence Broadbent, who has been studying in the American Horological Institute, Philadelphia, Pa., has returned to this city.

W. S. Taylor & Son, 70 Genesee St., have in their window a head and bust of a North American Indian, life size, and remarkably natural in every particular. It attracts a good deal of attention from passers-by.

J. T. SCOTT & CO.,
Wholesale Dealers in all kinds of
AMERICAN MOVEMENTS, GOLD AND FILLED CASES,
JEWELRY, CHAINS, ETC.,
4 MAIDEN LANE, - - NEW YORK.

**BIRTHDAY
BRACELETS**

Maker of Gold Jewelry.

Bracelets of every Description,
A SPECIALTY.



adjustable to any Arm.
appropriate Stone for Each Month.
arranged in Handsome Plush Cases.
Dozen in Each Case.
Selection Sent on Approval.

ALLING REEVES,
25 Maiden Lane,
NEW YORK.

☀ THE * "LONGFELLOW" * SOUVENIR. ☀

* * * FINEST LIKENESS OF THE POET IN SOUVENIR FORM. * * *

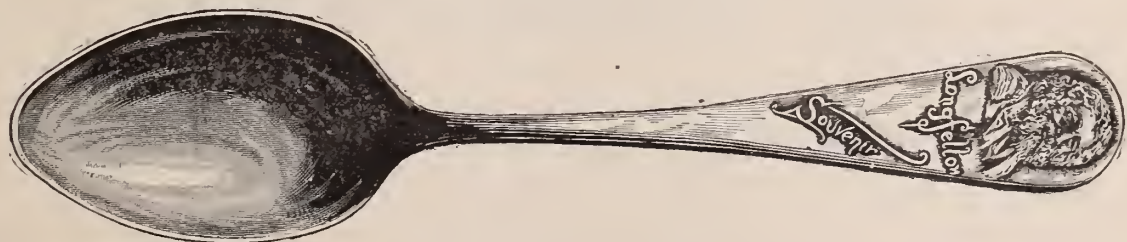

LIBERAL DISCOUNT.

SEND FOR PRICES.

Made in Tea, Coffee, and two designs of Orange.



BAY STATE SILVER CO.,

NORTH ATTLEBORO, MASS.

SOLID SILVER.

WE are now displaying a choice selection of Solid Silverware in the most advanced styles, embracing many choice designs and perfectly finished pieces of recognized merit. These goods are worthy of an inspection.

BRANCH OFFICES:

9 Maiden Lane.
137 & 139 State St., Chicago.
120 Sutter St., San Francisco, Cal.
36 Ave. de l'Opera, Paris, France.

WORKS, PROVIDENCE, R. I.

All communications should be
addressed to Broadway & 19th St.

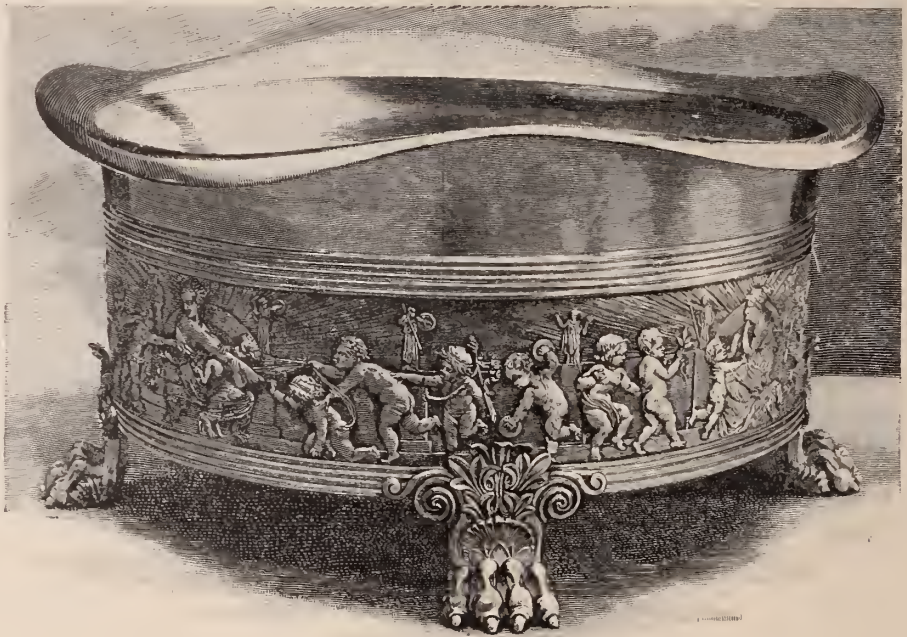

GORHAM MFG. CO., Silversmiths,
BROADWAY & 19TH STREET, N. Y.

ALFRED H. SMITH & CO.,

DIAMONDS,

182 BROADWAY,

COR. JOHN STREET,

NEW YORK.

33 HOLBORN VIADUCT, LONDON, E. C.

THE JEWELERS' CIRCULAR AND HOROLOGICAL REVIEW.

PUBLISHED EVERY WEDNESDAY BY

THE JEWELERS' CIRCULAR PUB'G CO.,
AT NO. 189 BROADWAY, NEW YORK CITY.

A JOURNAL DEVOTED TO THE INTERESTS OF
WATCHMAKERS, JEWELERS, SILVERSMITHS,
ELECTRO-PLATE MANUFACTURERS AND ALL
WHO ARE ENGAGED IN KINDRED BRANCHES
OF INDUSTRY.

Terms of Subscription, Postage Prepaid.

	PER ANNUM
United States and Canada, - - -	\$2.00
To all Foreign Countries, - - -	4.00
Single Copies, - - - - -	.10

ADVERTISEMENT.

Business letters, drafts, checks and post-office orders should be addressed to THE JEWELERS' CIRCULAR PUBLISHING COMPANY, No. 189 Broadway, New York city.

Manuscript from any quarter containing news or discussion of any technical subject within the field covered by THE CIRCULAR will be welcomed. Matter received that proves unsuitable or unavailable will be returned if accompanied by the necessary postage stamps.

Our editorial columns will contain our own opinions only, and we shall present in other columns only what we consider of interest or value to our readers. Applications to print advertising matter as news will not be considered.

Advertising rates in THE CIRCULAR are lower, considering the number of tradesmen reached by its large circulation, than in any other jewelry journal.

Notices of changes in standing advertisements must be received one week in advance, new matter can be received up to Saturday.

Member of the American Trade Press Association.

VOL. XXII. APRIL 29, 1891. NO. 13.

The best Organization in the Trade. NOW, more than any other, is the time of the year when jewelers fear the cracksman. With the advent of spring, the portals of the penitentiaries have been opened, and many of their choicest inmates have passed through them into the world once more to prey upon it. The issues of THE CIRCULAR for the past month have been remarkably rich in accounts of burglaries, the operations of which have been significant. There has been no desperate exploding of safes, a grapple and then a rush for life. The thieves have simply first used guile, then ripped the safe coolly and with calculation, and abstracted from it such goods as their judgment told them it was wisest to steal. In all these cases, the safes have been scarcely more than tin boxes, susceptible to the chisels and jimmys of the thieves. It seems that the jeweler who awakes of a morning to find himself a comparatively poor man, through the operations of burglars, is at least worthy the sympathy of his fellow man. If his safe is a burglar-proof one, and if he is a member of the Jewelers' Security Alliance, he truly is. If through negligence on his part or through the fear of the expense incurred he

has not placed in his establishment these two safeguards he may certainly be designated as a man of loose business methods. The first essential of prevention of loss by burglary is that the safe should be burglar-proof; the second, that the jeweler should be a member of the Jewelers' Security Alliance. In another portion of this issue may be read an article on the former subject, which, being a simple one, the article is practically exhaustive. Regarding the Jewelers' Security Alliance, words of commendation seem superfluous. Fully a thousand members recognize it as the best institution in the country, by far the best investment they can make of the expense incurred. Should ten dollars initiation fee with five dollars a year dues be considered an expense at all, when the protection afforded by the fact of mere membership to the Alliance is borne in mind? With this small obligation from each member the Alliance is placed in a position to perform for him far more effectual service, at times of need, than his local authorities. It is the boast of the cracksman that he has robbed his victim "clean," thus disabling him from pushing the pursuit for his apprehension. Such is the case if the victim relies for relief entirely upon the local authorities; if he is a member of the Jewelers' Security Alliance, he has called to his aid the services of the best trained force of detectives in the country—the Pinkington Detective Agency. The cracksman is cognizant of this, and the mere display in a jewelry store of the little certificate of membership to the Alliance, will cause him to give the establishment a wide berth. The jeweler appreciating these statements should need no force to compel him to have his name placed upon the rolls of the Jewelers' Security Alliance. Our Canadian neighbors have recognized the necessity of a protective organization, and as reported elsewhere in this issue, have just founded an institution of the same name and character as the one in the United States.

The News of the Trade.

WHEN THE CIRCULAR was changed from the monthly to the weekly form, its publishers promised the trade that they would perfect facilities for gathering all the news relative to the jewelry, watch and kindred industries of the country. This promise has been fulfilled, and each issue of THE CIRCULAR now contains far more and fresher news than any other jewelry journal. By actual calculation it contains each week 20 per cent. more news items than are contained in any other journal. The publication exclusively in THE CIRCULAR at their occurrence of such salient events, as the death of John P. Fellows, the failures of Sol. Bergman & Co., and the J. Steinmetz Jewelry Co., the finding of the body of Carl Swenson, the sentence of the burglars who robbed Frank Hoffa, the burglary of Raabe Bros., the death of George O. Herrmann, and the retirement of Otto Young from the World's

Fair directory, must cause the trade to feel that that journal is their real representative.

The Week in Brief.

The swindler who victimized many New York jewelers by representing himself to be John Spencer, of Norwalk, Conn., was arrested—D. S. Dever was arrested at Philadelphia, Pa., for the robbery of the store of J. F. Schmitt, Homestead, Pa.—A commendable ordinance against pawnbrokers went into effect at Memphis, Tenn.—Diamond was reported to have been found near Nevada O.—The Jewelers' Security Alliance held their monthly meeting—Philip L. Moen, president of the Washburn & Moen Mfg. Co., Worcester, Mass., died—A clever diamond swindler was captured at Washington, D. C.—A census bulletin of American precious stones and diamond cutting was issued—The store of F. G. Thearle, Jr. & Co., Chicago, Ill., was robbed during a thunder storm—The Maine Legislature voted to buy a \$1,000 silver set for the cruise *Maine*.—A clever swindler was arrested at Toronto, Ont.—D. W. Rowland, St. Thomas, Ont. a one time jeweler, died—An attempt at robbery was made on the store of A. S. Ferris, So. Norwalk, Conn.—A large American emerald was displayed in Providence, R. I.—At Culpeper, Va., a colored man was sentenced for breaking into the store of H. C. Burrows—A large haul of stolen jewelry was made at St. Louis, Mo.—The Canadian Jewelers' Security Alliance was organized in the Dominion—How Carl Swenson's body was found—Another watch club company got into trouble at New Orleans, La.—C. F. Pierce bought out an old business at Springfield, Mass.—The creditors of the J. Steinmetz Jewelry Co., Helena, Mon., were made known—Working jewelers in New York are endeavoring to combine—It was decided at Philadelphia, Pa., to dispose of the business of Hollinshed Bros. at sheriff's sale—The suit of Smith & Green, Providence, R. I., against Sipe & Sigler, Cleveland, O., came up in the latter city—J. A. Kuschke, Wilkesbarre, Pa., became embarrassed—An interesting decision regarding the duty on Bohemian glass was rendered at New York—A slight fire occurred at the Columbus watch factory—Albert Kamp, Sing Sing, N. Y., was swindled out of a diamond ring—The show window of William Mauch, St. Louis Mo., was smashed—The suit of A. W. Stott vs. G. M. Perine, at San Francisco, Cal., was decided in favor of the defendant—Lucy Gaidner, a society belle of East Orange, N. J., was sentenced for shop lifting—It was decided at Lancaster, Pa., to sell out the plant of the Lancaster Watch Co. at sheriff's sale—A permanent injunction was rendered against the Paillard non-Magnetic Watch Co.—L. M. Sigler was appointed trustee of the McBride & Marcellus Co., Cleveland, O.—The Jewelers' Security Alliance decided to take in hand the burglary of the store of Legrand Jackson, Norwalk, Conn.—Agnes Sommers, a jeweler of Wichita, Kan., shot a burglar.

New York Notes.

D. M. Stern has entered a judgment for 156.96 against Simon Stern.

L. Herzog has obtained a judgment for \$908.49 against G. A. Viemeister and G. C. Viemeister.

G. Reese, formerly with Mrs. Theresa Lynch, is about to open a jewelry store on Broadway between 31st and 32d Sts.

Fred Sulzberger, of Silberman & Sulzberger, has been confined to his house during the past week, suffering from an attack of the grip and bronchitis.

Judge Patterson, of the Supreme Court has denied the motion of R. C. Hubbard for a change of venue in the suit brought against him by the New Haven Clock Co.

The refinery of Wollstein & Sulzberger, in the rear of 19 John St., was damaged to the extent of \$1,000 by fire last Tuesday evening. The loss is fully covered by insurance.

Among the visitors to the National Convention of Theosophists, which Mrs. Annie Besant addressed in Boston, Mass., last Sunday was E. Aug. Neresheimer of E. Aug. Neresheimer & Co., 21 Maiden Lane.

Attorney Robertson acting for G. Tarrants, of Tarrants & Gismond, recently attached \$200 held by E. G. Buckingham, which was due to Oliver Bros., who failed several years ago. Mr. Tarrants was a creditor of the latter firm.

Last Tuesday, F. Lavendeyer, a druggist of Broadway and 4th St., was held in \$5,000 in the Jefferson Market Police Court, on complaint of B. Levy, 64 John St. The latter claims he gave the defendant over \$1,000 worth of jewelry on memorandum but never received the money or the goods back.

Last Friday Judge O'Brien, of the Supreme

Court Chambers, granted permission to the Sheriff to sell the property of the New York Smelting and Refining Co., which was levied upon by him prior to the appointment of the receiver. The sale is to satisfy executions which were issued on judgment, in favor of Joshua Hendricks and others.

The spade which was used by the Department Commander of the Grand Army of the Republic in the ceremonies of breaking ground for the Grant tomb last Monday was a superb specimen of American handiwork, bearing an inscription containing the chief events of Gen. Grant's life. It was made by the Gorham Mfg. Co., and donated by them to the Grant Monument Association.

J. C. Proudman, 307 Eighth Ave., is the possessor of a cat with a record. Two weeks ago the cat swallowed a piece of thread dropped on the floor by Mrs. Proudman, at the end of which was a needle. For three days the feline refused to eat, but seemed all right on the fourth day. Last Tuesday Mr. Proudman's little daughter extracted the needle from the cat's side. Mr. Proudman's store has been visited by many persons curious to see the animal.

There is exhibited in the window of a Fulton St. art store a papier maché copy of a silver vase made by Benvenuto Cellini. The original vase was unearthed by an American traveler several years ago in Italy. It stands about ten inches high, and looks like a huge drinking goblet, such as were used in Britain during the sixteenth century. Although its symmetry has been entirely destroyed by its long rest in the earth, a face surrounded by a wreath can be distinguished on the upper portion of the ornament.

Auctioneer J. T. Stearns last Saturday sold in the Post Office building, the jewelry that

was seized from a passenger on *La Bretagne* some months ago. None of the goods were warranted and in consequence brought very low prices. The first lot was sixteen heavy wedding rings. They sold for \$3.50 each. Sixty-six other rings of various kinds were next sold for \$36. Twenty-four pairs of spectacles brought \$28, and twenty-three pairs of earrings \$9.50. Sixteen chains were sold for \$7.25.

L. Straus & Sons last October imported two lots of Bohemian glass on which Collector Erhardt levied a duty of 60 per cent. under the McKinley act. The importers claimed that only 35 per cent. should have been levied under the Tariff act of 1883, the old act specifications regarding Bohemian glass having not been repealed, as they were inconsistent with the new act. Judge Lacombe, of the United States Circuit Court, last Tuesday held that the section referring to the glass in the old law was repealed and that Collector Erhardt's classification was correct.

A decision of great importance to traveling men was rendered by Judges Van Brunt, Daniels and O'Brien, in the General Term of the Supreme Court, last Friday. The case decided was that of a cutlery drummer, whose samples were lost in a railroad wreck and whose employers sued the railroad company for the goods. The substance of the decision was that if merchandise, belonging to another person, be placed in the trunk, and among the personal effects of a passenger on a railroad, although such company accepts the trunk for transportation as baggage in the usual manner, if their servants or agents have no knowledge of the absence of such merchandise, no liability will arise on the part of the carrier to the owner of the merchandise in case of its loss or destruction.

In view of the success of our little book of verses upon

BIRTHDAY GEMS,

Which has been generally adopted by the trade, we have now in print and shall shortly issue a miniature pamphlet, entitled

APOSTLE STONES,

Copies of which will be sent upon application, free of cost.

IMPORTER OF
PRECIOUS STONES.
Elevator Entrance, 2 John Street.

E. E. KIPLING, 182 Broadway, New York.

J. Macher will, on May 1, move from 38 to 44½ Maiden Lane.

G. Roellger, formerly of 8th Ave., has moved to Mansfield, Mass.

T. Lindenberg, 10 E. 14th St., has given a bill of sale to A. Tisch, for \$1,298.

The judgments which Gallinger & Co. confessed to B. Strauss, S. Trier & Son, and A. Ehrlich & Bro., were last week set aside by the Supreme Court.

Harris Levy, 174½ Bowery, had Isidor Katz, 332 Broome St., arrested last Sunday and held for trial on the charge of obtaining \$380 worth of jewelry from him under false pretense.

Rosenthal & Co., dealers in jewelry and curiosities, corner of the Bowery and Grand St., whose stock was injured by fire last week, are selling out the damaged articles at auction.

An attachment was last week issued against the Chicago Watch and Jewelry Co., formerly located in the Pulitzer Building, for \$500, in favor of Esselstyler, Ketcham & Stafford. This is the firm that is being prosecuted for conducting a watch lottery business.

A CIRCULAR reporter learned last Monday at District Attorney Nichol's office that Ferdinand W. Cahn, the thieving clerk of H. E. Oppenheimer & Co. was brought up for sentence before Judge Fitzgerald two weeks ago, and that sentence was suspended and the prisoner released.

Among the departures for Europe during the past week were: A. M. Kohn, of T. A. Kohn & Co., H. E. Oppenheimer, of H. E. Oppenheimer & Co. and S. Frankel, J. Frankel's Sons, New York, on the *Trave*; C. R. Smith, Providence, R. I., on *La Bourgogne*; Morris Green, New York, on the *Saalé*. Max Hartung, Chicago, Ill., arrived on the *Augusta Victoria*. Henry Zimmern, New York, will sail May 6 on the *Teutonic*, and H. H. Jackson, of Jackson Bros., New York, May 2, on the *Alaska*.

Judge O'Brien, of the Supreme Court, last Saturday signed the final order and judgment for costs in the suit of Charles McCulloh, of the Non-Magnetic Watch Co. of America, against the Paillard Non-Magnetic Watch Co. This order permanently enjoins the defendants from using the words "Charles A. Paillard" or "Paillard" on any watch movement manufactured by them. The defendants' office in the Corbin Building has been closed for several weeks, all their business being transacted from Peoria, Ill.

Secretary Condit, of the N. Y. Jewelers' Board of Trade, last week issued a circular to the members of the organization in which he indignantly denied the statement sent to the creditors of McBride & Marcellus Co. by Snow, Church & Co., that he was personally interested in the election of L. M. Sigler as trustee. After denying that he had any interests in the matter, beyond his professional position, he stated that the ground for his advising the election of Mr. Sigler was that a practical jeweler would undoubtedly realize more from the estate than one who had never had any experience in the trade.

C. G. Alford, of C. G. Alford & Co., had a narrow escape from instant death last Tuesday. He was taking his morning horseback exercise near his home in Orange, N. J., when the animal he was riding became frightened and threw him violently to the ground. He fell on his head and shoulder and was rendered unconscious. When he was carried to his residence it was feared he had suffered internal injuries, but subsequently, examination happily proved this was not so. Last Monday he was able for the first time to sit up and his physicians stated that he will undoubtedly be able to leave the house in about ten days.

The Week's Arrivals.

The following dealers from out of town were registered in New York during the past week: C. E. Davis, Boston, Mass., Occidental H.; J. W. Arand, Providence, R. I., Occidental H.; A. S. Vogt, Altoona, Pa., Astor H.; H. J. Dutton, Boston, Mass., Sturtevant H.; T. J. Quimby, Boston, Mass., St. Denis H.; F. Spencer, Boston, Mass., Barret H.; T. M. Day Jr., Pensacola, Fla., Gilsey H.; T. B. Williamson, Quebec, P. Q., Ashland H.; S. Lewis, Providence, R. I., Astor H.; W. A. Fletcher, Beaumont, Tex., Astor H.; W. E. Lapsley, Baltimore, Md., Oriental H.; A. P. Page, Boston, Mass., St. Stephens H.; W. D. Jennings, Fall River, Mass., Metropolitan H.; E. Hipotoola, Calcutta and Bombay, E. India, Metropolitan H.; F. D. Kenochan, Middletown, N. Y.; E. H. Wells, New Haven, Conn., Continental H.; J. N. Stimpson, Philadelphia, Pa., Coleman H.; O. H. Briggs, Providence, R. I., Normandie H.; H. W. Haydens, Waterbury, Conn., Normandie H.; W. L. Watrons, Waverly, N. Y., Gd. Central H.; C. S. Raymond, Omaha, Neb.; H. B. Greene, Boston, Mass., Murray Hill H.; G. M. Stevens, Boston, Mass., Imperial H.; R. P. Lee, Chicago, Ill., Astor H.; S. C. Tappin, Troy, N. Y.; P. R. Bradley, Boston, Mass., Astor H.; C. E. Buhre, Topeka, Kan.; H. Greenman, Richfield Springs, N. Y.

DORFLINGER'S AMERICAN CUT GLASS.

The Finest Crystal, Plain and Cut, made in the World.



EVERYTHING that is used in Glass, for the Table.

Sells as well as Silver-ware.

EVERY FIRST-CLASS JEWELER

C. DORFLINGER & SONS,



BEAUTIFUL, Artistic and Useful Pieces for Gifts.

Rivals the Diamond for Purity and Lustre.

SHOULD KEEP IT.

36 Murray Street, New York.

SEE PAGE 9.

BUY MYERS' MAINSPRINGS,

\$15.00 Per Gross.

M. MYERS, 7 Bromfield St., Boston, Mass.

CLASSIFIED INDEX TO ADVERTISEMENTS.

All Advertisements are entitled to one insertion under proper heading. Extra insertions, \$6.00 per Annum. Extra Headings \$12.00 per Annum.

Table with multiple columns listing categories (e.g., Assayers & Refiners, Auctioneers, Badges, Medals, etc., Books, Stationery, etc., Chronometers, Clock Manufacturers, Cut Glass, Diamonds & Precious Stone Importers, Diamond Cutters, Diamond Jewelry, Engravers and Designers, Eye Glass Holders & Chains, Gold and Silver Platers, Gold Jewelry, Gold Chains, Horological Schools, Hotels, Imported Clocks, Bronzes, Etc., Jewelry Repairers, Jewelry and Silverware Cases, Jobbers, Watches, Diamonds, etc., Lamps, Musical Boxes, Optical Goods, Order Work, Pens, Pencil Cases, Etc., Ring Makers, Rolled Plate Chains, Rolled Plate Jewelry, Safes and Locks, Scales, Seamless Wire, Settings & Galleries, Show Cases, Silk Guards, Silver Plated Ware, Sterling Silver Novelties, Sterling Silverware, Souvenir Spoons, Tool Manufacturers and Dealers, Typewriters, Watch Companies, Watch & Clock Dials, Watch & Clock Oils, Watch Keys, Watch Case Manufacturers, Watch Case Repairers, Watch Importers, Watch Materials, &c., Watch Repairers, Watch Springs) and corresponding page numbers.

Special Notices.

Rates 75c. per insertion for notices, not exceeding 3 lines; additional words 2 cents each. If answers are to be forwarded, postage stamps must be enclosed. Two insertions, 10 per cent. off; three insertions, 15 per cent. off; four insertions, 25 per cent. off. Payable strictly in advance.

Situations Wanted.

THE JEWELERS' CIRCULAR has a guaranteed circulation of over 10,000 copies weekly. It is, therefore, the best medium for reaching the trade. To demonstrate this to advertisers, notices in this column will be inserted free of charge during the month of April.

A NICKEL PLATER desires a situation; thoroughly understands the business; can give best of reference if required. Address, Plater B, this office.

DIAMOND LINE WANTED.—Mounted or loose; on salary and commission, by an experienced and reliable salesman. Address, Watson, P. O. Box 3278, New York.

SITUATION wanted as salesman by young man possessing highest credentials. Seven years' experience; salary moderate. Address, Box 375, JEWELERS' CIRCULAR.

SITUATION wanted as clerk in retail, or traveler for wholesale jewelry house; nine years' experience in retail jewelry business; can give best references; New York, Philadelphia or Boston preferred. Address A. B. C., care of THE JEWELERS' CIRCULAR.

SITUATION wanted by a young man as credit clerk; understands position thoroughly, as well as all office work, bookkeeping, etc. Good reasons for wishing to make a change. Address, H., P. O. Box 3306, N. Y. City.

SITUATION WANTED.—By first-class rapid watchmaker, jobber and plain engraver; young man of pleasant address; good set of tools; A reference. Address, G. W. C., 1125 Grand Ave., Pueblo, Col.

YOUNG MAN, twenty years of age, would like a situation with a jewelry or optical house; has had experience in both lines of business; satisfactory references. Address Johnson, care of THE JEWELERS' CIRCULAR.

SITUATION WANTED by a young man who is at present in business, and has been for the past nine years, but, owing to ill health, is obliged to get outside to travel for a line of watches, jewelry, silverware; have experience in optical goods; acquainted with the N. E. States mostly. P. S.—Do not expect the earth. Address F. T. C., Box 514, Westfield, Mass.

WANTED [a situation by a first-class watchmaker. Can also do jewelry jobbing and act as salesman. Have a full set of tools. Can refer to former employers as to ability, etc. Address, J. P. Ernst, 33 Hazel Ave., Wilkes-Barre, Pa.

Help Wanted

WANTED.—Optician and engraver, optician and watchmaker, and engraver who can assist in selling and displaying goods in a large Southwestern city; as engraver, work must be good; only competent men need apply, stating age, salary and references; steady positions are assured the right men. Address, Competent, care of THE JEWELERS' CIRCULAR.

For Sale.

A FINE ship chronometer for sale cheap. Address: A. C. Taylor, Cedar Rapids, Iowa.

FOR SALE.—On account dissolution of partnership, three iron safes; one fine "Herring Patent Champion"; also fixtures, shop tools, etc. Apply to Moore & Horton, 11 Maiden Lane, New York.

ABOUT \$3,000—half cash easy payments on balance, will buy, Wholesale and Retail Jewelry Store, established fifteen years. Best location in City of 350,000. Retiring from business. A bonanza. For particulars, Address, B., Care JEWELERS' CIRCULAR.

FOR SALE.—A Frodsham marine chronometer, in perfect order; good as new; \$60.00. Renner Brothers, 129 Waverly Place, N. Y.

OWING to poor health, I wish to sell my business, situated in a prosperous California town, population 2,000, 3 hours from San Francisco by rail, to become overland line. Rich fruit, farming and dairy country. Perfect climate. Business established 23 years, good run of work. Capital required, \$2,500. Address Sixty-Eight, care of THE JEWELERS' CIRCULAR.

FOR SALE—Rare good business opportunity for any watchmaker with \$1,300 cash; good-paying jewelry business, in a rapidly-growing town in Western New York; rent low; good trade and plenty of repairing. Present owner not able to look after it. Address U. S. C., care of THE JEWELERS' CIRCULAR.

FOR SALE—in the New South, stock of jewelry, silverware and fixtures; all new in the past year; opportunity seldom offered; death the reason for selling. Address E. F. Winegar & Co., Johnson City, Tenn.

"UNCLE SAM."

(Patent applied for.)

A Souvenir Spoon that needs no explanation for its existence.



The first and only **Distinctly American Souvenir Spoon.**

This unique and characteristic design appeals to foreign visitors not less than to patriotic Americans, and from its strong simplicity, broad application and distinct American character, will doubtless prove the most successful souvenir spoon on the market.

"Etched with name of city desired in bowl."

Alvin Mfg. Co.,

860 BROADWAY,

Union Square,

NEW YORK.

Miscellaneous.

OPTICIANS.—We offer, very cheap, a brand new surface-grinding lathe, with complete set of moulds + 0.25 Ds to 18 Ds; correspondence solicited. Address, A. Jay. Cross & Co., 18 W. 23d St., New York.

TO MANUFACTURERS of Clock Movements.—Wanted, a good eight-day movement, to fit onyx and marble cases; send particulars and price for quantities to Case Manufacturer, care of THE JEWELERS' CIRCULAR.

WANTED.—On Maiden Lane or vicinity, a window and bench room for a watchmaker. Address, H. L., care of THE JEWELERS' CIRCULAR.

W. F. A. WOODCOCK'S SCHOOL FOR WATCHMAKERS, Winona, Minn., offers unrivaled facilities for acquiring a thorough practical knowledge of every branch of the business. Terms very reasonable.

WORK FOR THE TRADE.—All kinds of watch and jewelry repairing. Skillful workmen, prompt attention and satisfaction guaranteed. Address, A. W. Johanson, 176 & 178 Market st., Chicago, Ill.

To Let.

BROADWAY, 194, Room 12, light office, \$25 per month, including gas, heat and cleaning.

The Attleboros.

C. W. Fisher and wife returned Saturday from California.

Sumner Blackinton, of W. & S. Blackinton, was in town this week.

John Stanley arrived home Friday from a Southern business trip.

Edward Miller left Monday for Virginia, hoping to regain lost health.

S. W. Gould is able to attend to his duties after a three weeks' serious illness.

E. O. Pollard, with T. Totten & Co., and Ella G. Hinton were married Friday.

J. H. Gould was delegate to the convention of the Republican League at Cincinnati, O.

Bates & Bacon have been pushed on their orders and have found it necessary to run nights.

Patrick Crosby died Saturday and was buried Monday. Many floral tributes were received from fellow jewelers.

Otis Crossman, employed by G. A. Dean for the past 22 years, has resigned his position for a situation with W. A. Sturdy & Co., Charley, this State.

A new jewelry firm will soon be ready for business. The partners will be E. T. Bright and E. D. Gilmore, and the firm will be known as E. D. Gilmore & Co.

W. H. Herring, with Stanley Bros., celebrated the twentieth anniversary of his marriage Friday, and was on that evening surprised with over fifty beautiful presents.

It was reported Thursday morning that a daring attempt was made the night previous to enter the store of A. S. Ferris, South Norwalk, Conn. A porter says he looked across the street about 1.05 o'clock and saw three men standing near the door of the store. He went outside and the men started and ran up North Main St. When Mr. Ferris arrived at the store, he says he had considerable difficulty in unlocking the door, and upon investigation he found that a skeleton key had been inserted in the lock and that an attempt had been made to force the windows open.

Cincinnati.

A. G. Schwab arrived last week from a few days on the road.

Homer & Co. started for early closing on Saturday, at 1 P.M.

Frank Herschide has a souvenir spoon in process of construction.

Louis Albert is en route home. He is satisfied with his initial trip.

S. Lindenberg, of Bene, Lindenberg & Co., left Sunday night for a four weeks' trip.

Clemens Hellebush, Jr., wife and sister-in-law sail for Europe the first week in June.

D. Schroder arrived home last week from a short, but very satisfactory trip. He left again Sunday night.

Chas. Ankeny, manager of the wholesale department of Duhme & Co., has been in Chicago, Ill., on a business trip.

A. & J. Plaut have had new cabinets put in between their cases, which are used for the larger pieces of art work.

J. C. Dueber, who sustained a number of cuts by being hurled from a cable car last Monday, is able to be out again.

J. F. Meyer, Harrison, O., was in town this week replenishing his stock. It is said Mr. Meyer will soon be a benedict.

John Hanley, the Cincinnati diamond thief and general robber, has been found guilty and convicted of stealing jewelry in San Francisco, Cal.

A call has been issued for the Ohio Watchmakers' and Jewelers' Association to convene at Canton, on June 9. Some very important matters will be acted upon.

Adam Vogt, Louisville, Ky., passed through this city on his way to New York. This is a little early, but Mr. Vogt is taking advantage of the lull in trade.

Among the delegates to the great Republican League held here this week, were J. W. Pyle, Bowling Green, Ky.; W. H. Reid and wife, Parkersburg, W. Va.; and H. O. Witte, Jackson, O.

A. Herman is a leading spirit in the Cincinnati Wholesale Jewelers' Association, and their next meeting is looked to for a boom in the proposed Jewelers' Board of Trade. He was away at the last meeting and no action was taken.

M. C. Ellis, formerly with B. F. Norris, Alistar & Co., Chicago, Ill., has been engaged by Oskamp, Nolting & Co., this city, to represent them on the road. George Lewis, late of the L. Bauman Jewelry Co., St. Louis, Mo., is also a new addition to this house.

John Holland has some very curious looking things in his window this week which prove upon investigation to be the elements that compose his celebrated fountain pen. Long pieces of rubber tubing in various sizes show the holders before they are turned or engraved. A pile of shavings show what is done in the turning process. Various

lengths of the tubing in preparation show the construction of the pens. It is quite a study, and attracts quite as much attention as Duhme & Co.'s silver factory scene.

One of the best representative Ohio souvenir spoons is that of A. & J. Plaut, which they have now in the factory. Charles Goetheim is the designer. He has embodied all the symbols of the State and city. Without a sketch of the celebrated Davidson fountain, no souvenir would be considered typical. This feature is embossed in the bowl. The stem represents a branch of a buckeye tree, the bark cut in relief; it is attached to the bowl by two miniature buckeyes; on the top of the stem is the city seal, also in relief, on which the statue of Cincinnatus, the Roman Consul, stands with his plow at his feet, and the message in his hand that calls him from the field to the Senate. These spoons which will be on the market in a few weeks, are made in tea, coffee and orange sizes.

Cleveland.

The legal action of Smith & Greene, Providence, R. I., against Sipe & Sigler, of this city, for \$6,362.90 and interest from Nov. 5, 1889, was put on trial Friday morning in the Court of Common Pleas. The action is on an account for a quantity of chains bought by Sipe & Sigler from Smith & Greene, and for which payment was refused. Sipe & Sigler in answer claim that the



The most desirable line of 16-size movements on the market.

goods are not as warranted, and in cross-petition ask \$16,000 damages for putting out to the retail jewelry trade the line of chains which is alleged to have been injuriously poor and often to have been returned by the purchasers.

L. E. Hoffman has opened a fine new wholesale and retail store at 97 Euclid Ave. He held his opening last Tuesday.

A large plate glass window in P. L. Miles' store was broken by a drunken expressman driving his horse against it about 11 o'clock Saturday night.

On Wednesday, at 3 P. M. the auction sale of the Sumner Bros. stock, now owned by Sipe & Sigler, was commenced. H. C. Briggs is the auctioneer. The sale will take place daily at 3 and 7.30 P. M. until all is sold.

The Bowler & Burdick Co. sued J. F. Hoffman & Co., of Collinwood, this State, last week in the Court of Common Pleas for \$544.80 on an account. Hugh Gorman, as agent of the Queen's Insurance Co. of Liverpool, was garnishee, and an attachment was levied on the defendants' safe in Collinwood. In the affidavit for attachment the Bowler & Burdick Co. swore that the defendants were about to move and dispose of their property and convert it into money to defraud creditors and place it beyond their reach.

Philadelphia.

Jacob Ickler has sold out his jewelry store at 230 North Eighth St., to Happig & Co.

Simon Muhr has been elected treasurer of the Hachnasath Orechein (Sheltering Immigrants), Society.

J. T. Sandman, the diamond dealer of 227 South Eighth St., is resting at Atlantic City. S. T. Loftis is recovering from the grippe at the same resort.

D. S. Dever, who was arrested for the Homestead burglary as reported in another portion of this issue, was on Thursday taken to Pittsburgh.

Partridge & Richardson, this city, were recently assessed duties at 45 per cent. *ad valorem* on some buckles dutiable as jewelry. The importers protested, and the claim for duty as jewelry was last week sustained at New York.

The National Retail Jewelers' Association contemplate sending a representative to Canton, O., to attend the annual session of the Ohio Watchmakers' and Jewelers' Association, and President A. S. Goodman will probably be the man.

Dr. F. O. Stout, with the Spencer Optical Mfg. Co., New York, early in May will begin a series of monthly lectures on Optics before the National Retail Jewelers' Association. These lectures are to be illustrated by means of a stereopticon and diagrams.

The following jewelers, located in Chestnut St., between 7th and 8th Sts., have petitioned against the bill pending in Council to widen Chestnut St., at that point: Wm. Morris & Co., Henry Euler, A. R. Harper & Bro., L. A. Scherr & Co., Louis Atkinson, Charles De Young, E. J. Herty, J. C. Kelley, J. McKelvey and L. P. White.

Alderman John Wing, well-known to the jewelry trade as manager of the watch and clock-oil business of his father-in-law, Ezra Kelley, is at present acting Mayor of New Bedford, Mass., in the absence of S. Ashley in the West.

DIAMONDS.

Wm. S. Hedges & Co.,
Importers of Diamonds,

And Manufacturers of DIAMOND JEWELRY,
 No. 170 BROADWAY,
 S. E. Cor. Maiden Lane, } New York.

27 Holborn Viaduct, London.

BOSTON HEADQUARTERS FOR ILLINOIS, HAMPDEN

And all other American made Movements. Also a full line of Jewelry, Diamonds, etc.

E. F. WILSON & CO., 409 WASHINGTON ST., BOSTON, MASS.

VALUABLE INSTRUCTION BOOKS

FOR SALE BY

THE JEWELERS' CIRCULAR PUBLISHING CO., 189 Broadway, N. Y.

- Goldsmiths' Handbook**, containing full instructions for the Alloying and Working of Gold. By GEO. E. GEE. Price, post-paid, \$1 25
- Silversmiths' Handbook**, containing full instructions for the Alloying and Working of Silver. By GEO. E. GEE. Price, post-paid, 1 20
- Practical Instruction in the Art of Letter Engraving.** By G. F. WHELPLEY. Price, post-paid, 2 00
- Kemlo's Watch Repairer's Handbook.** Illustrated. For beginners and advanced workmen. By F. KEMLO. Price, post-paid, 1 25
- Watch and Clock Making** (with 69 diagrams). By DAVID GLASGOW, President of the British Horological Institute. Price, post-paid, 2 00
- Treatise on Watch Work, Past and Present.** By the Rev. H. D. NELTHROP, M. A., F. S. A. Numerous Illustrations. Crown, 8vo, cloth. Price, post-paid, 2 50
- Treatise on Modern Horology in Theory and Practice.** By M. CLAUDIUS SAUNIER. Translated by JULIEN TRIPPLIN, Besancon Watch Manufacturer, and EDWARD RIGG, M. A., Assayer in the Royal Mint, London. Price, 15 00
This valuable work comprises 832 large octavo pages, with 78 Wood Cuts and 21 colored double-page, copper-plate Engravings, is printed on excellent paper and bound in half calf, with a handsome and appropriate ornament in gold on front cover.
- Watch and Clockmaker's Handbook, Dictionary and Guide.** 1889 Edition. Revised. By F. J. BRITTEN. Price, post-paid, 2 00
- Watchmaker's Handbook.** Latest edition, revised and enlarged. Same Author and Translator, and intended as a Companion to the Treatise. Illustrated by 14 double-page Copper-plate Engravings and numerous Wood Cuts; cloth cover. Price, post-paid, 3 50
- Handbook for Opticians.** By W. BOHNE. Illustrated. Price, 2 50
- Detection and Correction of Visual Imperfections. (With Test Type.)** By Dr. C. A. BUCKLIN, A. M., M. D. Price, post-paid, 1 00
- The Watch Jobber's Handy Book.** A Practical Manual on Cleaning, Repairing and Adjusting Watches; with Information on the Tools, Materials, Appliances and Processes employed in Watchwork. By PAUL N. HASLUCK. 100 Illustrations, 0 85
- The Clock Jobber's Handy Book.** A Practical Manual on Cleaning, Repairing and Adjusting Clocks; with Information on the Tools, Materials, Appliances and Processes used in Clockwork. By PAUL N. HASLUCK. 100 Illustrations, 0 85

- Prize Essay on the Balance Spring and Its Technical Adjustments** (Baroness Burdette Coult's Prize). By M. IMMISCH. Cuts, crown, 8vo, cloth, 1 00
- A Handbook of Precious Stones.** By M. D. ROTHSCHILD. Cloth. Illustrated, 1 00
- Electrolysis; a Practical Treatise on Nickeling, Coppering, Gilding, Silvering and Refining of Metals and Treatment of Ores by Means of Electricity.** By H. FOXTAINE. With 34 Illustrations, 3 50
- Electro-Plating.** A Practical Handbook on the deposition of Copper, Silver, Nickel, Gold, Aluminum, Brass, Platinum, etc.; with descriptions of the Chemicals, Materials, Batteries and Dynamo Machines used in the Art. By J. W. URQUHART, 2 00
- Electro-Deposition; a Practical Treatise on the Electrolysis of Gold, Silver, Copper, Nickel and other Metals and Alloys, with Descriptions of Voltaic Batteries, Magnets and Dynamo-Electric Machines; Thermopiles, and of the Material and Processes used in every Department of the Art and Several Chapters on Electro-Metallurgy.** By A. WATT. 3 50
- The Metallic Alloys.** A Practical Guide for the Manufacture of all kinds of Alloys, Amalgams and Solders used by Metal Workers, together with their Chemical and Physical Properties and their Application in the Arts and the Industries; with an Appendix on the Coloring of Alloys. From the German of A. Krupp and Andreas Wildberger. Illustrated by 15 Engravings. 2 50
- A Treatise on the Transit Instrument as Applied to the Determination of Time.** By LATIMER CLARK, M. I. C. E. 2 00
- Manual of the Transit Instrument,** as used for obtaining Correct Time. By LATIMER CLARK, M. I. C. E. 40
- Turning Lathes.** A Manual for Technical Schools and Apprentices. A Guide to Turning, Screw Cutting, Metal Spinning, etc. 194 Illustrations. Edited by JAMES LUKIN, B. A. 1 00
- Workshop Receipts** for the use of Manufacturers, Mechanics and Scientific Amateurs. By ERNEST SPON. 2 00
- Gems and Precious Stones of North America.** By GEO. F. KUNZ. A popular description of their occurrence, value, history, archaeology, and of the collections in which they exist; also a chapter on Pearls. Illustrated with 8 colored plates and numerous minor engravings. 10 00

ALL PRICES PAYABLE IN ADVANCE.

Pacific Coast Notes.

W. D. Nunamaker, Redding, Cal., is in insolvency.

Mears & Lowe, Hollister, Cal., have sold out to J. F. Lowe.

Andrew Riley has opened a new retail store at Fresno, Cal.

A. P. Tartar, of Illinois, has purchased the store of J. A. Morse, Los Gatos, Cal.

George Ducommon, from Chippewa Falls, Wis., is opening a large establishment at Portville, Cal.

C. A. Conger, Santa Cruz, Cal., recently of Springer & Conger, will soon engage in business for himself. He will open his new store early in May.

J. B. Trickey & Co., who recently came here from Lincoln, Neb., and succeeded to the business of L. Braverman & Co., San Francisco, Cal., have engaged Hugh Mauldin, jeweler and diamond expert.

Louis Balbach, watchmaker, who has been with C. F. Smith, San Francisco, Cal., for the past year, is preparing for a trip to Philadelphia, where he will attend the American Horological Institute to perfect his knowledge of his chosen vocation.

George Done, one of the most notorious burglars on the Coast, has been held for trial at Seattle, Wash., for stealing \$5,000 worth of diamonds and jewelry, the property of a Mrs. J. S. Atwood. The thief tried to sell a lot of gold rings to a back street jeweler in that city.

In the Superior Court, at San Francisco, Cal., Judge Wallace, last week, rendered judgment for the defendant in the case of A. W. Stott vs. G. M. Perine. The latter bought a pair of earrings on the instalment plan from Mr. Stott, for \$3,000. After paying \$2,000, he asked the jeweler for the return of the money, as he had agreed to do, if the goods did not meet the approval of Perine's father, who is an expert, on his return from Europe. Mr. Stott would not give back the money, but brought suit for the other \$1,000. Perine entered a counter-claim for the return of his \$2,000, which has been granted by the Court.

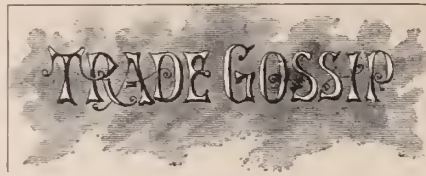

Goldsmith Bros., the refiners and assayers, 63 Washington St., Chicago, Ill., have just gotten out a vest pocket edition, giving full instructions in regard to testing and buying old gold and silver. It is mailed free upon application.

All the salesmen of Joseph Noterman & Co., Cincinnati, O., are out, and have begun to send in orders. Wm. Pfluger has the Southern territory, and will be gone several weeks. Jos. Noterman, Jr., has Ohio, and will run in in a week or so to restock.

D. Jacobs & Co., Cincinnati, O. are one of the live jewelry firms of that city who believe in personally touching the trade, and each member of the firm has his field that he systematically works, making two or three trips each season, as the occasion may require. This year the firm increased their stock and enlarged their force so that the results show a balance on the right side over the same time last year. Ferd. Jacobs has just returned and reports a very satisfactory trip.

S. F. Merritt, Springfield, Mass., would like to call the attention of the trade to the claim that he was the first to make rolled plate wire on a solid rod and to the fact that he has made all his eyeglass holders and chains of this wire, which is seamless and solid. All his chains are soldered with gold solder. He has swaged all pins and pin points for the last six years and now is making hair pins of this same patent seamless wire with hardened prongs, which will be of superior quality. A description of these specialties will be found on another page.

Heretofore electricity has been looked upon as a luxury that only those in luck could afford to indulge in. The Darche Electric Co., manufacturers of electric alarm clocks, 37 Clark St., Chicago, Ill., have revolutionized this theory and demonstrated that

they have an electric clock within reach of the poor man. Their invention has "caught on" and they are just now filling orders placed last February. Marked improvements have recently been made in the case of the clock which materially enhances its appearance without any advance in the cost.

Peoria, Ill., is not to be entirely lost to the country as a watch tool and material center pending the solution of the problem of the future of the watch factory located there. F. F. Ide, who was superintendent of the Peoria Watch factory so long as it was in operation, and upon whose shoulders rests a head that is full of inventive genius in horological matters, has started the F. F. Ide Mfg. Co. for the manufacture of watch tools. Around the country are numerous inventors who have the conception of new devices, but can neither materialize them themselves nor get them made from their ideas. Mr. Ide will attend to these persons' wants and bring to their service the aid of the skilled mechanic. This new factory occupies big floor spaces, opens on the street and is located centrally. It is fitted with mechanical devices of all kinds for making intricate tools and instruments. Mr. Ide has called to his assistance a good-sized force of skilled watch tool mechanics, among whom are G. B. Underwood, formerly of the Aurora watch factory, and latterly foreman of the finishing-room of the Peoria Watch factory; J. F. Wright, whose long service in the punch and die departments of the Elgin and Illinois factories makes him a veteran, and W. H. Wells, formerly foreman of the machine shop of the Illinois factory. Mr. Ide has already many tools upon the market that watch makers would be unable to do without, such as his poisoning tool, universal main spring winder and a number of others, all of which will be kept up to their popular standard of usefulness. Just now the whole force are at work on a new instrument for the Geneva Optical Co., which will be put upon the market shortly. Mr. Ide's seventeen years' experience fully fit him for taking contracts for patent and intricate pieces of machinery.

THE * CHRISTOPHER * COLUMBUS * SPOON.

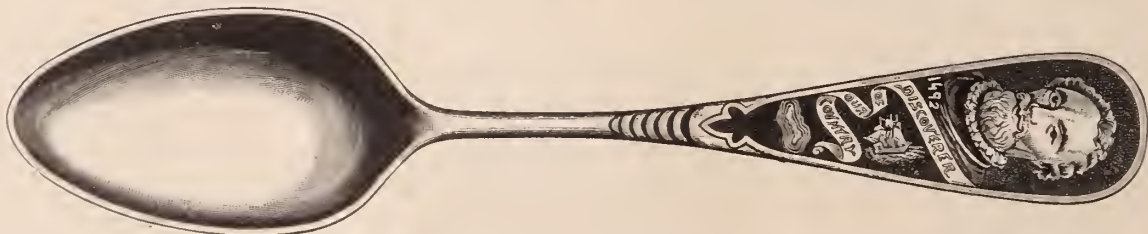

A Souvenir ante-dating anything in American History, only needs to be shown, to sell.

Made in all sizes and kinds, in sterling silver only. Prices: Teas, \$2.25, A. D. Coffees, \$1.50, Orange, \$2.75. Extra for gold bowls. A discount of 25 per cent. to the trade. For circular and prices address,

CHAS. M. MCFARLAND & CO.,
415 MAIN STREET, **WORCESTER, MASS.**

Henry Cowan, 409 Washington St., Boston, Mass., has secured the New England agency for Emrie's watch guaranty record book.

H. E. Oppenheimer, of H. E. Oppenheimer & Co., New York, sailed last week for the diamond markets of Europe. He expects to return in a short time with one of the finest assortment of stones obtainable.

A new catalogue supplement of the F. Kroeber Clock Co., 360 Broadway, New York, shows some very handsome designs in enameled iron, French marble, onyx and fancy clocks. This firm's line of cuckoo clocks comprises all styles and prices.

E. A. Whitney, 403 Washington St., Boston, Mass., keeps a stock of Boss and Keystone cases that is complete in every detail. He also has a large and varied assortment of chains and charms, samples of which he will send to any reputable jeweler.

D. D. Palmer, Waltham, Mass., has produced drilling diamond dies for drawing wire which have succeeded in drilling to $\frac{1}{1000}$ of a centimetre in width, a gain of about $\frac{1}{1000}$ inch $\frac{1}{1000}$ of inch being about the smallest hole ever drilled before in a diamond. This discovery will have many practical applications in the arts.

When it comes to a hard strain, the ordinary pleyer is, as a rule, unable to withstand the test. The Barnard Patent Pleyer just introduced by F. W. Gesswein, 39 John St., New York City, does not contain this evil and promises to meet with a big demand among manufacturing jewelers. It is made of cast steel, but has a patent bracing that makes it one of the strongest pleyers on the market. The handles are hollow curved, and when in use the strain is applied direct to the centre of the nippers instead of at the joint.

The following is a copy of a postal card received from a celebrated oculist by the Geneva Optical Co.:

PARIS, 4 Rue Volney, 25 M., '91.

Geneva Optical Co., 23 Washington St., Chicago.

DEAR SIRS.—I received a few months ago a "Geneva Lens Measure" with no other remarks than the address of your house. Thus, I do not know whom to thank for this most precious gift. I have indeed, made use of the instrument, since that time, and find it very practical and at once an exquisite workmanship. I do not fail to recommend it to the colleagues and pupils, since the instrument really deserves it.

Yours very truly,

DR. E. LANDOLT.

We learn from the Ryder & Dearth Co., 146 Westminster St., Providence, R. I., that the number of cuts and electrotypes used by jewelers, judged by their orders, are far ahead, this year of any previous one. Though running to the full capacity of their large establishment, the company find that their facilities are put to the test, to fill, as promptly as they would desire, the orders coming to them from all sections of the country. This state of things we take to be a healthy indication of the appreciation of their work among the jewelers. They make a specialty of getting out a catalogue complete, from the making of the wood-cuts to delivery of the books.

KREMENTZ & Co.,
182 & 184 Broadway, NEW YORK,

MANUFACTURERS OF

GOLD JEWELRY,

14-K. BEAD NECKLACES,

— AND —

KREMENTZ ONE-PIECE COLLAR BUTTONS.



Our line, composed of

Chain Mountings, Chains, Neck Chains,
Crosses, Bead Necks, Bracelets, Bangles,
Earrings, Glove Buttoners, Garters,
Locketts and Charms, "Mount Hope" Buttons,

Initial Scarf Pins, Bar Pins, Cuff Pins, Jersey Pins,

is of high grade rolled plate, and as a guarantee that they will wear well we stamp them F. & B.

Our sleeve button is the "Mount Hope" and is the best in the world.

FOSTER & BAILEY,

Providence, R. I.



W. ROSENTALL,

79 NASSAU ST., N. Y.

Manufacturer of

Silk Vest Chains,

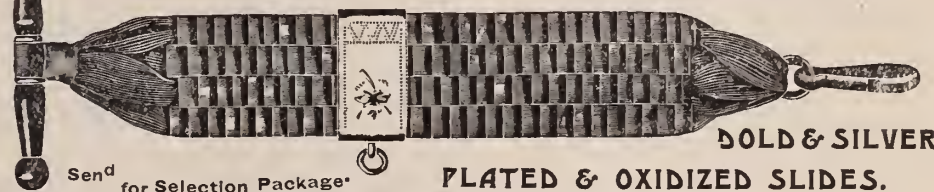

GOLD & SILVER

PLATED & OXIDIZED SLIDES.

Send for Selection Package

BUY THE "BARON" SPECTACLE.



The best Periscope Spectacle in the World for Opticians to sell for \$1.00. Sole manufacturers, LEVY, DREYFUS & CO., 11 Maiden Lane, New York.



Patented Jan. 17th, 1888.

C. G. HARSTROM,

PEEKSKILL, N. Y.

Will send sample of this all steel adjustable Case Spring, any size, Swiss or American, for ten cents. Stamps.

The following speak for themselves:

MR. NYE. WINONA, MINN., Nov. 15, 1890.
DEAR SIR: It affords me great pleasure to send you this voluntary recommendation of your justly celebrated watch oil. It is being used and appreciated by the graduates of W. F. A. Woodcock's Watchmakers' School, from the Atlantic to the Pacific, and I recommend it in the highest terms to all good watchmakers.
I am, yours respectfully,
W. F. A. WOODCOCK.

COLUMBUS, NEB., Feb. 15, 1891
WM. F. NYE, New Bedford, Mass.

DEAR SIR: Your kind favor to hand.
Thanks for prompt reply. Referring to the test of your Watch Oil by D. L. Brown, I have tried all kinds of oil for watches, and am free to state that I could not be induced to use any other than your brand, as it's the only oil one can rely on in cold climates. I often have watches carried by my customers three years without cleaning or re-oiling.

Yours truly,
A. J. ARNOLD

WILLIAM F. NYE,

MANUFACTURER OF

The finest Watch and Clock Oil made,

NEW BEDFORD, MASS.

BRAXMAR JEWELER. MANUFACTURING. 47 CORTLAND ST. NEW YORK.

BADGES

SEND FOR CATALOGUE B.

LARGEST MANUFACTURER OF BADGES AND MEDALS IN AMERICA. SEND FOR SAMPLE.

BURDON'S SEAMLESS.

THE ORIGINAL
And only Genuine



AND
Perfect Seamless Filled Wires
IN THE WORLD.
Sold to all Manufacturers
alike.

Burdon Seamless Wire.

TRADE-MARK.

The success of the BURDON SEAMLESS FILLED WIRE, like that of all important inventions, has been followed by deceptive and imperfect imitations. For the protection of

ALL JOBBERS AND RETAILERS,

we authorize manufacturers who so desire, to affix upon the tag, card or label accompanying the articles made from this wire, this registered trade-mark owned by this Company.

The bird-on-wire is a guarantee that the goods are made from the original Burdon Seamless Filled Wire, the reputation of which has been firmly established among the best dealers for more than two years. The perfection and qualities of the Burdon Seamless Wires are always guaranteed. All Dealers (jobbers and retailers alike) should, therefore, demand goods made from the original Burdon Wire, and avoid imitations which are offered as "just as good."

BURDON SEAMLESS FILLED WIRE CO.,

109 to 119 and 127 Summer Street,

PROVIDENCE, R. I.

TELL A. BEGUELIN,
IMPORTER OF
WATCHES.

Watch Materials, Tools and Glasses,

No. 71 NASSAU STREET,

(UP STAIRS.)

NEW YORK.

Sole Importer of Material for the

"Bijou," "Victor," "Boston," "Bristol," "Adelphia," "Jockey Club," "Wallingford," "Caesar," "Lady Racine" and "New Haven" Bena Watches.

Selling Agent for materials for **LONGINES** and **AGASSIZ** Watches.

AMERICAN WATCHES,

ALSO STEM WIND WHEELS

Importer of Full Line of Swiss Watches, AND FRENCH CLOCK GLASSES.

S. COTTLE & CO.,

MAKERS OF

FINE JEWELRY AND SILVER NOVELTIES,

No. 86o Broadway, NEW YORK.

R. & L. FRIEDLANDER,

Wholesale Jewelers,

AND

JOBBER'S IN AMERICAN WATCHES,

Tools, Materials and Optical Goods,

65 & 67 NASSAU STREET, N. Y.

Factory, 50 BOND STREET.

Send Business Card and we will mail you our Watch and Jewelry Catalogue, No. 12, and our Tool, Material and Optical Catalogue, No. 14.

READ THIS LETTER:

HENRY ERBSMEHL,

Watchmaker & Jeweler,

Watches, Clocks, Jewelry and Silverware.

MILFORD, DEL., March 4th, 1891.

MESSRS. R. & L. FRIEDLANDER, New York City.

GENTLEMEN: It gives me pleasure to recommend to the trade your Monarch Main Springs, for American Watches. They are, without exception, the best Main Springs that I have ever used. I have tried all makes within the last 25 years, but have found none equal to the Monarch Springs. They are uniform in force and temper; out of 6 dozen springs, I have lost but two.

I remain, yours truly,

HENRY ERBSMEHL.

Try our Monarch American Main Springs, \$12.00 PER GROSS, \$1.00 PER DOZEN
POSITIVELY NO GOODS SOLD AT RETAIL.

Established 1872.

PLAINVILLE STOCK CO.

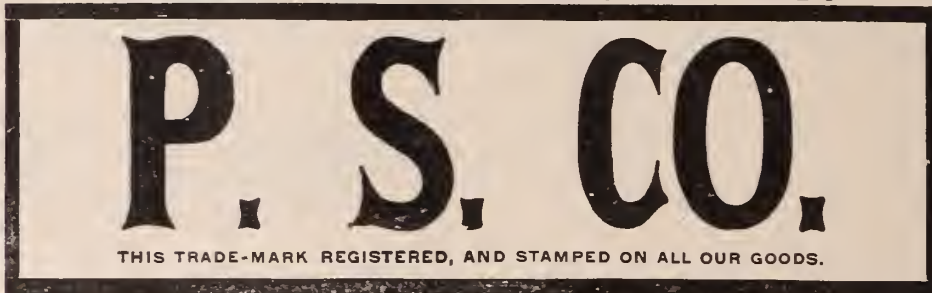

BROOCHES, SCARF PINS, DROPS, SETS.

FACTORY AT PLAINVILLE MASS

SAMPLES AT 176 BROADWAY, NEW YORK

DIAMOND SETTINGS.

GALLERIES.

HOLLOW BALLS, ETC.

BLANCARD & CO.,

36 & 38 JOHN STREET,

SEND FOR OUR

NEW YORK.

CATALOGUE.

S. C. JACKSON, 180 BROADWAY, NEW YORK,
MANUFACTURER OF

Fine Cases for Jewelry, Silverware, Etc.,

ALSO SHOW CASE TRAYS AND FANCY HARD WOOD WORK.

Samples sent on application. Estimates furnished.

Designers see page 8
of the new Crescent catalogue.

Brief History of Gold and Silversmithing.

(Continued from page 38, April 1.)

PART VII.
PROCESSES.

HANDLES, spouts, and all decorated appendages which have to be soldered to a coffee-pot or any other vessel, are made either by stamping, electro-typing or casting. In the last instance a model of cast iron or brass is obtained from modeled wax or plaster, according to the usual process, and carefully chased with a thorough artistic finish. With this, moulds of fine sand are made, into which melted silver is poured. When the metal has cooled, the cast pieces are taken up, and after being shorn by filing the superfluous parts, they are sent to the chasers.

Electro-typing, and also the engraving of stampers deserve to be dealt with, at full length, in separate articles; besides, if these processes may be considered as being of frequent use in our line, they do not, properly speaking, belong to gold and silversmithing, since they appeal in no way to the special talents which workers of precious metals should possess.

The views reproduced here give a sufficient idea of the general appearance of the chief departments in a silversmith's workshop in Europe.

Modern soldering, scratching, polishing, frosting and gilding processes are well known. It is, therefore, unnecessary to describe them here.

Relief decoration on metal, called in French *ciselure*, is done by three different processes: 1st, the work on pieces whose design is roughly obtained by casting; 2d, the chasing which consists in cutting the metal,

borrowed from the mould. He must correct the deviated outlines, make the plain parts which are usually rough and granulous, smooth and even. It may appear, at first sight, that an average chaser, provided with proper tools, ought to be able to do such work well and with ease. Yet this seldom is the case. If the chasing of reproductions is entrusted

vessel, which is narrow at the top in repoussé, chasers first make a sketch of the design on the outside of the piece, then emboss the work with the *ressing* or marking tool, and finally bring out all the details with ciselets. A careful artist often begins by making a model, which he copies so as to avoid the risks in feeling his way about. Some obtain from



GENERAL VIEW OF THE FACTORY.

to the artist whose mind created and whose hand executed the model, the result is bound to be satisfactory; but when another has to do it, the style and character of the artistic piece may often be misinterpreted, and the design somewhat disfigured. An indifferent chaser can spoil a good model, as a poor translator can weaken and, perhaps, thoroughly alter a beautiful poem.

The second process, the cutting or the glypting of the design out of the metal, is chiefly employed in steel, and in a special line, in gold and silver. It is a branch of sculpture. The design is first roughly sketched by cutting and removing a part of the metal with the help of gouges, chisels, scorpers and gravers variously edged, all of which must be of tempered steel. The chaser drives these sharp tools about the piece with a hammer. When the gross work is done and the relief design sufficiently brought out, all the details being rough-drawn, the artist uses fine tools, called by the French *ciselets*, *rifloirs*, *matoirs*, *molettes*, etc., and gradually gives the required finish to the different parts of the piece. He proceeds carefully, with a light hand, well knowing that a slight mistake may spoil the whole work. He considers how for instance he can correct a relief line or curve imperfectly drawn or replace a loss of metal due to over-cutting or filing, since he dares not use solder.

this model a mould in plaster, and reproduce on the back or inside of the vessels all the hollows of that mould, which if done mathematically (with the help of compasses for depths) is bound to give to the outside of the piece the exact appearance of the model. The last part of the work, the chasing, is executed on the vessel, which is filled up with cement, in using rather blunt tools, so as to avoid piercing the metal.

The Repairs of the Barrel.

THE click spring must not be too strong; beside the screw, its foot must also have a footpin, so that it can neither rise up, nor come out of depth, nor yet pass downward and drag upon the barrel; the point must enter securely down to the bottom of the ratchet teeth, and be of a good and sufficient shape to prevent the return of the clickwork. The screws of the dust-cap must be rounded off below. "The screws of the clickspring are the only ones of the whole watch which I do not temper," says Herman Groesch in his Manual for Watchmakers, "because very disagreeable consequences would ensue if one of these screws were to break off in the barrel bridge; all the other screws, especially those for the stop-work and other parts, must be tempered, the heads and slits cleaned, and the points polished."

It is necessary occasionally to make the barrel holes smaller and to bush them. The barrel must run flat and true and the holes fit well; if the latter are too large even by a trifle, and the metal only barely thick enough, they may in exceptional cases be made



FINISHING DEPARTMENT.

or glypting out of it, ornaments and figures; and 3d, the repoussé, or embossed work executed with punches of various shapes.

In the first instance, the chaser must bring out all the details of the model which the metal piece he has to manipulate imperfectly

Of the repoussé process I must only say a few words, as I have already described it. To decorate a vase, a coffee-pot or any other

ARE YOU DISSOLVING PARTNERSHIP
 ARE YOU HAVING DULL TRADE
 ARE YOU ABOUT TO RETIRE
 ARE YOU OVERSTOCKED
 ARE YOU REMOVING



IF YOU ARE, COMMUNICATE WITH

A. J. COMRIE,
 AUCTIONEER,

Specialty of Jewelers' Sales. 16 West 125th St., New York.

WATCHMAKING SCHOOL.

Have your Young Men become No. 1 Artisans by sending them to

R. Jaegerman's Watchmaking School.

For particulars, write to

R. JAEGERMAN, Manager,

No. 622 Locust St., ST. LOUIS, MO.

MUSICAL JACOT & SON,
 298 Broadway,
 New York

Send for Catalogue.

BOXES.

Musical Boxes Repaired.



Geneva Optical Co.,
 MANUFACTURERS OF
 Spectacles, Eye
 Glasses, Lenses
 and Cases.
 23 WASHINGTON ST.,
 CHICAGO.

The Highest Grade
 — OF —
Electro Silver

Plated Ware

Is Stamped with the



ROGERS TRADE-MARKS.

MANUFACTURED BY

The Wm. Rogers Manufacturing Co.,

P. O. DRAWER 30,

HARTFORD, - CONN.

smaller with a centre punch and then be smoothed within with a round broach or a polished turning arbor.

If the barrel holes are too large and untrue, they are bushed with drilled bouchons, suitably turned in turning arbor. In bushing, especially in riveting, great care is necessary, because by too strong a hammering the part may easily draw out of shape—become untrue. Sometimes it is necessary to bush the holes full and then centre again which can be done in the lathe.

THE UPRIGHTING OF THE BARREL.

If the holes are not too large, and the barrel does not run true, try first what can be done by moving the cover in the groove to different places; if in this manner a place is found where the barrel runs true, make a mark on the cover and side, or you may also drill in a pin passing partly through the cover into the bezel of the barrel.

If nothing can be done by shifting the cover, find a place which runs closest, mark it, and give a few light taps with the hammer upon the edge of the cover, by laying it upon a small anvil and an underlay of silk paper; hit it at the place of the cover at which the tooth rim runs farthest from the card held against it. Do not hammer too much at once; it is occasionally necessary to take off a little with a file from the opposite side of the cover; when doing this, of course, the repairer must keep in view the contour of the edge. It is self-evident that a barrel with the cover opposite to the tooth rim is meant here; one with the cover on the same side with the teeth, requires the opposite treatment.

A barrel, which otherwise runs true and even, stands obliquely sometimes, when it is screwed fast to the bridge; this may be due to too great shake of the ratchet or too large a hole in the bridge, or else to a bad recess in the bridge; this may be remedied occasionally by screwing the bridge upon the plate, centering from below, and making the recess parallel to the plate, but at the same time making the recess for the cap deeper. If it is a one-bar spring-arbor with mounted ratchet, either one hole or both holes of the outer arbor pivot would have to be bushed.

THE STOPWORK.

The end of the screw of the star must not project; it is to be rounded off well and polished. If the screws are so short that, as frequently happens, they can no longer be shortened in the lantern of the screw-polishing machine, this may be done by using a strip of very thin brass, about twenty-five millimeters long, and from three to four millimeters broad, furnished with suitable small holes for this purpose, in which the screws may be inserted, and which are then laid upon cork or the filing wood.

The screwhead of the star must not scrape on the dial; the stopwork must work with entire security, especially at the end of the winding, when the full tooth turns up. It is very advisable to round off both parts, star and snail-stop, a trifle on the lower side with

UNITED STATES OPTICAL CO.

15 Grand River Ave., Detroit, Mich.

Manufacturers and Jobbers of

Spectacles and Eye Glasses.

Special Attention given to Prescription Work, and Repairing by Skilled Workmen.

Our facilities for the manufacture of SPECTACLES and EYE GLASS CASES are such that we can quote lowest prices.

WILL FURNISH SAMPLES ON APPLICATION.



The Latest, Simplest and Best.

Patent Screw Bezel Case.

CROWN B, No. 2

AND

LION GOLD FILLED.

VICTORY ROLLED PLATE.

In presenting to the trade our New Patent Screw Bezel Case, we desire to call attention to the following characteristic feature in its construction, viz :

THE DUST OR MOVEMENT BAND,

which is independent of the case, and is made with



two lugs extending beyond the periphery of the band and fitting into two slots prepared for their reception in the centre of the case.

These lugs have a thread cut on their outer edge which meets and corresponds with a thread on the case centre, and when thus combined, the thread on the lugs and that on the centre form a continuous thread, so that when the bezel is screwed on the centre it engages the dustband along with the centre, and thus practically makes the bezel, the band and the centre one piece. In this way all shaking of the band is prevented and it is thus held securely in its place.

The disengaging of the band is accomplished by unscrewing the bezel and simply raising the band by means of one of the lugs attached thereto.

The points of excellence which we claim for our case, are :

(1.) Simplicity and Novelty of Construction. There is nothing complicated about it. The band can be engaged or disengaged with ease by any one.

It is entirely new, being unlike anything put on the market in the way of a Screw Bezel Case.

(2.) Compactness and beauty of shape.

There is nothing clumsy or cumbrous about our Case, and with respect to the second point of excellence, it is without a rival.

- A. Lugs on movement ring engaging centre.
- B. Notches in centre to receive movement ring lugs.
- C. Screw in Bezel engaging centre and movement ring.

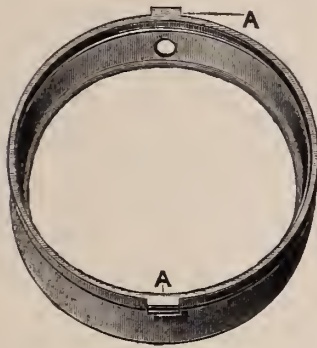

PATENTED NOVEMBER, 1890.

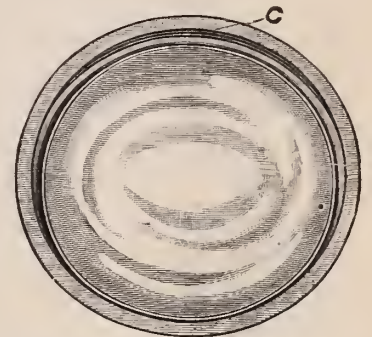

A NEW Departure.

This case is perfect, either as hunting or open face, simple in its construction, durable and perfect in every respect. "A good seller."

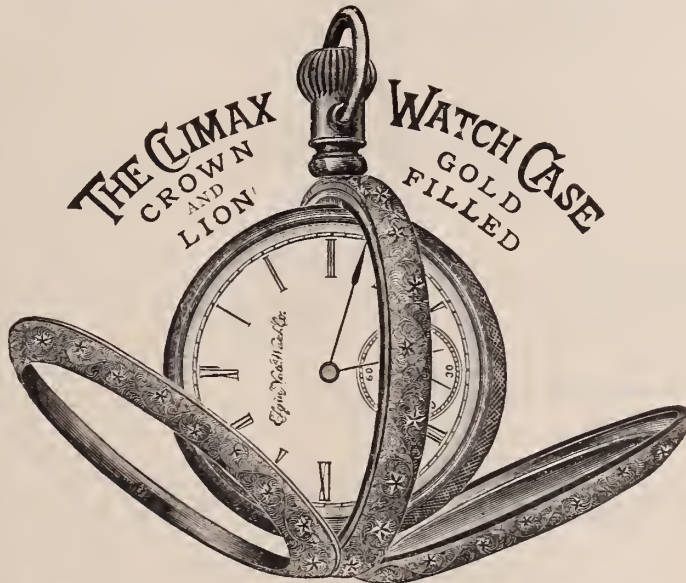

LION GRADE,

10-KARAT.

ALSO MADE IN

CROWN B, No. 2,

14-KARAT.



H. MUHR'S SONS,

New York : 20 JOHN STREET.

Philadelphia : 629 & 631 CHESTNUT STREET.

Chicago : 141 STATE STREET.

Ludwig Assen.
Danvers, Mass.
Mar. 21, 1891.

18 JOHN ST. NEW YORK.

MOORE & HORTON,
MANUFACTURERS OF
SOLID GOLD JEWELRY,
No. 11 Maiden Lane, New York.
Fine Imitation Diamond Goods a Specialty.
Selection Packages sent on Application.

The New Trenton



18 SIZE, SEVEN JEWELS, NICKEL.
HUNTING AND OPEN FACE S. W.

Quick train, straight line lever escapement, safety centre pinion, enamel dial, beautifully damaskeened and exceedingly attractive in appearance.

**THE BEST LOW PRICED WATCH
EVER PRODUCED.**

For Sale by the Jobbing Trade.

TRENTON WATCH CO.

TRENTON, N. J.

ALEX. WIEDERHOLD,
20 MAIDEN LANE, N. Y.,
REPAIRING JEWELER.

Jobbing sent to me by mail or express will be repaired and returned promptly. Prices Moderate and First-class Workmanship Guaranteed.

a slip of oil-stone or a piece of wood covered with emery paper in a turning arbor. The snail-stop must, under no condition, touch its recess.

In order to satisfy one's self of the security of the stopwork, fasten the arbor by its winding square in the clamps, which you press with the last three fingers against the thumb hole of the left hand, while thumb and forefinger catch around the tooth rim of the barrel and rotate it from left to right. During this performance try with a pegwood, held in the right hand, to move the star in a direction opposed to the rotations, so that its points offer themselves to the snail-stop under the most unfavorable circumstances. If under these circumstances the stopwork works all right, it will also perform securely in the future.

TO FIT BOUCHONS.

It was said above that it was sometimes necessary to bush a hole. For this purpose a bouchon is selected as small as the pivot will admit, for the smaller the bouchon is, the neater will be the job. Open the hole of the plate or cock, so that the bouchon which should be previously lightly drawfiled at the end, will stand, with a slight pressure, upright in the opened hole of the plate or cock. Then with a knife cut it across at the part where it is to be broken off, so that it may break very readily when required to do so. Press it in the plate on the side the pivot works, break off, and then drive it home with a small centre punch. In every repair of this nature, notice should be taken of the amount of end shake of the pinion, and allowance made by leaving the bouchon so that any excess may be corrected. To finish off the shoulder end, a small chamfering tool should be used with a hole smaller than the pivot one to receive a fine brass wire serving as a centre to prevent the tool changing its position while being used; or the wire may be put through the bouchon hole, and then the hole of the tool may be left open. This method is a far more expeditious way than using the mandrel.

To Color Soft Solder.—The following is a method for coloring soft solder so that when it is used for uniting brass, the colors may be about the same. First prepare a saturated solution of sulphate of copper—bluestone—in water, and apply some of this with a stick to the solder. On touching it then with an iron or steel wire it becomes coppered, and by repeating the experiment, the deposit of copper may be made thicker and darker. To give the solder a yellow color, mix one pint of a saturated solution of sulphate of zinc with two of sulphate of copper, apply this to the coppered spot and rub it with a zinc rod. The color can be still further improved by applying gold powder and polishing. On gold jewelry or colored gold the solder is first coppered as above, then a thin coat of mucilage or isinglass solution is laid on and bronze powder dusted over it, making a surface which can be polished smooth and brilliant after the gum is dry.



THE PRINCESS LAMP.

The handsomest decorative Lamp ever produced. Made in largest variety, and richest designs by

GEORGE EAKINS & SON,
616 Chestnut St., Phila., Pa.

Made expressly for fine Jewelry Trade.

SEND FOR DESCRIPTIVE PAMPHLET AND PRICES.

KENDRICK & DAVIS,

LEBANON, N. H.

MANUFACTURERS OF THE

Standard Dust Proof Watch Key.



After this date all Keys of this Style will have number stamped on each Key.

FOR SALE BY THE TRADE.



To Clean Files.—Files may be readily cleaned of grease by holding them for a moment in a steam jet from a blow-off cock.

Fire-proof Cement.—A very tenacious and fire-proof cement for metals is said to be prepared by mixing powdered asbestos with water-glass, to be had in any drug store; it is said to be steam-tight and resist any temperature.

Lubricant on Oil-stone.—A correspondent to an exchange says that he has used petroleum on his oil-stone for the last few years, and that it serves all purposes. The stone is always clean and in working order, and those he threw aside formerly, as being too hard, serve admirably when wetted with petroleum. He uses a mixture of two-thirds petroleum and one-third oil, mixed, on his milling machine, and believes no other lubricant exceeds it in usefulness.

Colorless Varnish.—A colorless varnish, suitable for optical instruments, prints, oil paintings, and hard white wood, may be made by dissolving two and half ounces of shellac in a pint of rectified spirits of wine. To this, about five ounces of well burnt animal charcoal, which has recently been heated, must be added, and the whole boiled for a few minutes. If on filtering a small portion of the mixture through blotting paper it is not found to be perfectly colorless, more charcoal must be added until the desired result is obtained. When this has been achieved, the mixture is to be strained through a piece of silk and filtered through a blotting paper.

Brass Finishing by Acids.—Many articles of brass cannot readily be finished by the file or abrading substances, owing to the intricacies of their surfaces. Especially is this true of brass castings of an ornamental character. But a most elegant finish can be obtained by means of acids, which may be protected, if desired, by means of lacquer or varnish; the acid finish, however, is generally preferred without the addition of a varnish. If the work to be finished is greasy, it should be cleaned by heating and dipping in acidulated water—vinegar and water, or washing soda in water—and then in clear water. The finishing bath may be either nitric acid, two parts; water, one part; or one part sal-ammoniac, one part sulphuric acid, one part nitric acid, one part water; all by measure, and the sal-ammoniac to be dissolved in water until a saturated solution is obtained. The articles should not be allowed to remain in the acid more than ten seconds, then taken out, plunged into clear, cold water, then into soapy water, and dried in hot sawdust.

OPPENHEIMER BROS. & VEITH, Watches, Diamonds and Jewelry,

2 Tulp Straat,

AMSTERDAM.

35 Maiden Lane,

NEW YORK.

SPECIALTY:

Recognizing the demand for

HAMPDEN MOVEMENTS and DUEBER CASES,

We have made a Specialty of these lines of goods and carry a large stock of same.

HAYDEN W. WHEELER & CO.,

2 MAIDEN LANE, NEW YORK,

Have an unusually large and varied stock of

FANCY STONE RINGS,

CONSISTING OF

MOONSTONE, GARNET, TOPAZ, AMETHYST, PERIDOT,
PEARL, DOUBLET, SARDONYX,

And the various combinations of these Stones.

DIAMONDS, ♦ WATCHES, ♦ JEWELRY.

EZRA KELLEY'S

Famous Watch, Clock and Chronometer Oils,

RECEIVED AT THE

EXHIBITION UNIVERSELLE, PARIS, 1889,

The only Award of Merit given to Manufacturers of American Oils

It is to the interest of every Watchmaker to use in his work the *Best Oil* obtainable, regardless of cost Mr. Kelley's claim to be the foremost manufacturer of Oils, giving the best results, is not based upon his own assertion, but is founded upon the fact that wherever his Oils have been exhibited in competition with other makes, subject to an examination of experts, they have received the highest *Award of Merit*.
For sale by all the Leading Jobbing Houses.

HENRY GINNEL & CO.,

GRIMSHAW & BAXTER, EUROPEAN AGENTS,
35 GOSWELL ROAD, LONDON, ENGLAND.

GENERAL AGENTS,
31 Maiden Lane, NEW YORK

LOUIS NEWMAN, JR.

GOLD AND SILVER

Plater, Fire Gilder and Colorer.

Gilding by a New Process. Watch Cases, Jewelry and Novelties, Work stands acids, and in finish equal to Gold.
36 & 38 JOHN STREET, NEW YORK.

WIGGERS & FROELICK,
60 NASSAU ST., NEW YORK,
Sample Cases and Trays

For Watches, Jewelry, Optical Goods, Etc.

WE STRIVE TO MAKE THE BEST

Essex Watch Case

COMPANY,

T. B. HAGSTOZ, President.

TRADE



MARK

6 Maiden Lane, N. Y.

OFFICE,

NEWARK, N. J.

FACTORY,

GOLD FILLED CASES.

THE "MOLL PITCHER" SPOON.

(REGISTERED TRADE MARK.)

Moll Pitcher, of whom the poet Whittier wrote, was a noted Fortune Teller of Lynn, many years ago.



MOLL PITCHER.



We are receiving orders from the Trade all over the country and our sales are constantly increasing. Dealers who order once, soon order more.

PRICES.

Coffee Spoons, - - - - - \$1.25	Orange Spoons, - - - - - \$2.25
" (gold bowl), - - - - - 1.50	" (gold bowl), - - - - - 2.50
Tea Spoons, - - - - - 2.00	Trade discount:—15 per cent. 30 days, 3 per
" (gold bowl), - - - - - 2.25	cent. extra, 10 days.

Send for a sample line (one spoon each style). We are confident they will meet with ready sale.

W. F. NEWHALL, Jeweler,

52 MARKET STREET,

LYNN, MASS.

Jules Jürgensen

OF COPENHAGEN.

The reputation these watches have maintained for Fifty Years has never been equalled, being made on strictly scientific principles, and no expense spared to give the Best results in mechanism and timekeeping qualities.

SOLE AGENTS.

John C. Hyde's Sons,
No. 22 MAIDEN LANE.

ESTABLISHED 1856.

WILLIAM PARK,
Stone Seal Engraver,

Arms, Crests in the highest style of Art. Also Gold Rings, Silver Seals, Brass and Steel Seals engraved SUPERIOR to Stone Seal engraving. Dies cut for Envelope Stamping in best Style.
26 JOHN STREET, N. Y.

HENRY FERA,
IMPORTER OF DIAMONDS,

AND DIAMOND BORTZ,
Diamond Cutting and Polishing Establishment,
10 Maiden Lane, NEW YORK.

No.

60



No.

200

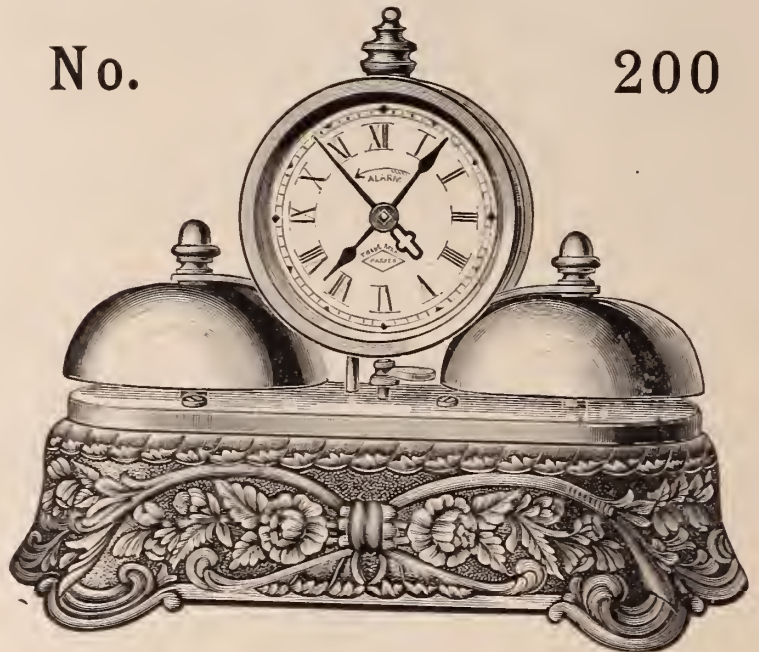

NEW * CONSTRUCTION.

THE ALARM MOVEMENT in these clocks is a New Construction and is superior to any other on account of Improved Escapement.

There is no escape wheel, nor are there any pallets to wear rapidly away, as in all prior alarms.

The sound is Electrical, and it is produced without the expense, care and nuisance of maintaining a Battery.

Sold by all Wholesalers.

THE PARKER & WHIPPLE CO., MERIDEN, CONN.

Chrome Steel in Jewelers' Safes.

PERHAPS no matter is more worthy of careful consideration by the jewelry trade in the furnishing of their business quarters, than the selection of the necessary safes for the storage of their precious wares. Aside from the convenience in the interior arrangement of compartments, etc., the question of material used in the construction of the safe is of the greatest importance, for to be of any practical value, a jewelers' safe must above every other consideration be thoroughly burglar and fire-proof. It is not enough to have the safe equipped with the most improved burglar alarm system, to trust to the faithfulness of the night watchman, or to rely upon reimbursement by insurance companies. The alarm may not alarm, the watchman may not watch, and insurance is a meagre compensation, when the labor and trouble incurred by a loss of valuable stock is considered.

The jewelers should look to it that the safe itself is impregnable. Then, when the day

is done and the safe doors close on the major part of his stock, he may be assured that it will be there the next morning when the blinds are taken down. Of the materials used in the building of safes, vaults, etc., none so effectually resist the efforts of the ingenious burglar as Chrome steel. This material cannot, when properly hardened, be cut, sawed, broke or drilled, as it is much harder than the material of which any chisel, saw, hammer or drill is manufactured.

Carbon or ordinary steel is a combination of iron and carbon while Chrome steel is a combination of iron and chromium, the proper properties of which are accurately weighed, great care being taken to have them exactly correct to every grade. Uniting



perfectly in alloy, these metals become integral in unity, producing a uniform steel

which is much superior to carbon steel. Chrome steel is used exclusively for burglar-proof work by many of the larger safe manufacturers, it being furnished them in the celebrated 5-ply combination plates, Chrome steel and iron, shown in the illustration. These plates are rolled from ingots and consist of alternate layers of Chrome steel and iron. Any tool after penetrating the layer of iron is immediately dulled and its further progress stopped when the layer of steel is encountered.

Like everything else of value, this popular steel has encountered imitations, and the trade mark of the real material should be examined. This trade mark consists of a double triangle enclosing the letter C; above the triangle is the word Chrome, and below the word, Adamantine; on one side of the triangle is the letter C, and on the other the letter S.

The Chrome Steel Works, Brooklyn, N. Y., are the sole manufacturers of genuine Chrome steel.

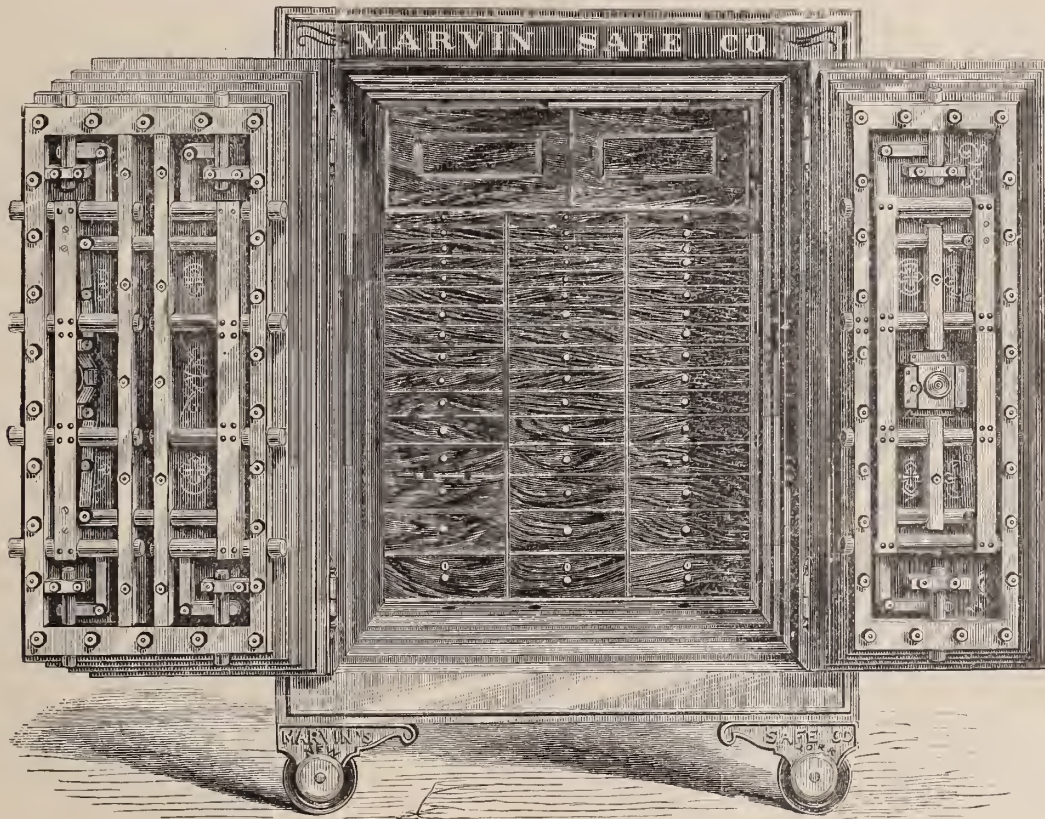

The above cut represents, very imperfectly, a modern fire and burglar-proof safe for the use of jewelers, designed and built by the Marvin Safe Co. The safe is lined throughout its entire interior, sides, top, bottom and back, with consecutive layers of the celebrated five ply combination plates of chrome steel and iron, as shown in the illustration. The doors are also built up with consecutive layers of the same metal, and are fitted with heavy steel bolt frames, massive round bolt work, and highest grade combination locks with side-shaft spindles. The doors are also fitted with tongues and grooves, planed out of the solid metal. The grooves are filled with a plastic substance, so that when the doors are closed and forced into position by the compressing levers attached to outside, the door joints are made air and watertight, and absolutely proof against the introduction of explosives. This mode of construction really combines two distinct safes—a fire-proof and a burglar-proof—in one safe, with but one set of doors. The fire-proof filling used by the Marvin Safe Co. is patented and is guaranteed to be absolutely free from dampness, rust, or loss of essential qualities through evaporation. The Marvin Safe Co. have been in active business for the past fifty-four years and their safes enjoy a world-wide reputation. The works and general offices of the Company are located at 88 to 92 South Fifth Avenue, New York City, with salesrooms at 265 Broadway, New York, and at 723 Chestnut Street, Philadelphia.

A Remington Standard Typewriter

Will Economize Time, Reduce Labor, Preserve Health, Save Money, Prevent Errors.



SEND FOR ILLUSTRATED CATALOGUE.

Wyckoff, Seamans & Benedict,
327 Broadway, New York.

G. F. FEINIER,
MANUFACTURER OF
WATCH CASES,
Repairing of Every Description,
NO. 9 BOND STREET, NEW YORK.
Key-Wind Cases Altered to Stem-Wind, and made same as New. English Cases Altered to take American Movements.

ARTIFICIAL EYES!

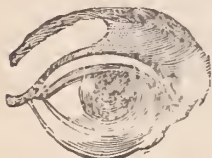

STOCK ORDERS of Selection Packages.

Largest Assortment.

GENEVA OPTICAL CO.,
22 Washington St. Chicago

H. H. HEINRICH,
12, 11 & 16 John St., New York.
Manufacturer of



MARINE CHRONOMETERS.
Silver Medal, Paris Exhibition, 1889.
A large stock of new and second-hand Marine Chronometers on hand. All my second-hand Chronometers are thoroughly overhauled, refinished and re-adjusted. Rented out at \$5.00 per month, payable in advance. No rent charged if bought within a certain time. Terms to suit customers. Marine Chronometers repaired and adjusted for the trade.

SWARTCHILD & CO.,



Our Complete Catalogue, illustrated, will be sent to any one forwarding us their address, free of charge.

We give special attention to mail orders. They are filled promptly the same day that they are received.

76 and 78 State Street, Chicago.

Chicago College of Horology,

SUCCESSORS TO

THE CHICAGO HOROLOGICAL INSTITUTE,

IS ACKNOWLEDGED by those who have investigated the subject to be a

FIRST-CLASS INSTITUTION,

Where those who desire to learn the art of WATCH MAKING and ENGRAVING can obtain the

BEST PRACTICAL INSTRUCTION.

New features are continually being added. It is the aim of those conducting the management of the College to make it the

BEST INSTITUTION of the kind IN THE COUNTRY.

C. R. HART, General Superintendent,

CHICAGO COLLEGE OF HOROLOGY,

CHICAGO, ILL.

WRITE FOR PROSPECTUS.

VACHERON & CONSTANTIN,

GENEVA, SWITZERLAND.

FINEST QUALITY OF WATCH MOVEMENTS, FITTING ALL SIZES OF AMERICAN CASES.



CHAS. LEO ABRY,

Agent for the United States and Canada.

41 and 43 Maiden Lane, NEW YORK.

Newark.

Frederick Felger, senior member of the firm of F. & F. Felger, will sail for Europe, to-day, on the steamer *Werra*. Mr. Felger will visit his native land, Germany, and spend the summer in travel.

Harry Fowler, an employee of William Riker, who was arrested on Wednesday last on the charge of having stolen gold from his employer's establishment was discharged on Thursday night, as Mr. Riker refused to make any charge against him.

Business in many of the large factories is dull, although extensive preparations are making in the way of designing new goods for fall trade. Several novelties have been brought out during the past week, among which is a neat watch charm in solid gold, combining a star and crescent, encircled by a wreath in enamel and colored stones.

Lucy Gardner, of East Orange, who is charged by Stern Bros., the dry goods house, New York, with larceny of jewelry and other articles, was on trial at the County Court rooms several days last week. This case has attracted considerable attention on account of the prominence of the defendant in Orange society, and the peculiar methods alleged to have been employed by her in obtaining the goods. The value of the articles stolen is placed at \$21, but already several hundred dollars have been expended in prosecution and defense of the case. The

jury brought in a verdict of guilty on Saturday last after being out less than two hours. Sentence will be pronounced on May 4th.

An executor's sale of securities belonging to the late Isaac A. Alling was held at the office of the Newark Fire Insurance Co. on Friday last. Some of the securities sold, the prices given were as follows: One registered bond of Delaware and Hudson Canal Co., 7 per cents., 107½; five coupon bonds of the Central Railroad of New Jersey, 5 per cents., 111; five coupon bonds of the Essex Passenger Railway Co., 6 per cents., 111½; two coupon bonds of the Baltimore and Ohio, 5 per cents., 104; five coupon bonds of the West Shore Railroad, 4 per cents., 101½; four Newark City Ice Co. coupon bonds, 6 per cents., 95; three coupon of the Pennsylvania Railroad Co., 4½ per cents., 103.

Jean Tack, 215 Market St., has recently invented and will soon put on the market, a new cash register of considerable merit. It is a fancy desk with a money drawer in it, and exposed on the top of the desk is a slab of glass, which has an aperture exposing a portion of a web of paper which passes from one roll to another. A sale is recorded on the exposed part of the paper, and when a button is pressed, the drawer springs open while at the same time the written record slips along under the glass slab, so that it cannot be erased or altered, but is still exposed to view through the glass. Mr. Tack has samples on

exhibition at his store, which attract much attention.

The two new jewelry concerns incorporated under the laws of New Jersey as reported in THE CIRCULAR, and which are to be conducted on the plan recently inaugurated by W. B. Chaffin & Co., and Thurber, Whyland & Co., of New York, have succeeded in placing all their stock and will soon commence operations. The stock of the C. G. Alford & Co., is divided into preferred and common, the first being entitled to cumulative and preferential dividends of 7 per cent, payable out of earnings. C. G. Alford & Co., of New York, wholesale jewelers, have taken all of the general or common stock of the above corporation, and have agreed to act as managers and officers of the company for ten years. The preference in allotment of the other stock has been given to the employes and customers of the old firm. The plan is generally approved and will no doubt work successfully.

Every jeweler who is interested in burglar-proof safes should read the advertisement of the Marvin Safe Co., page 43 of this issue. The Marvin safe is made of chrome steel, the only recognized drill proof metal known, and at the present time, when jewelry stores are continually being entered by burglars, it is interesting, as it becomes the duty of every jeweler to himself to see that his stock is secure from depredation when he leaves his store at night.

NATIONAL SOUVENIR SPOONS.

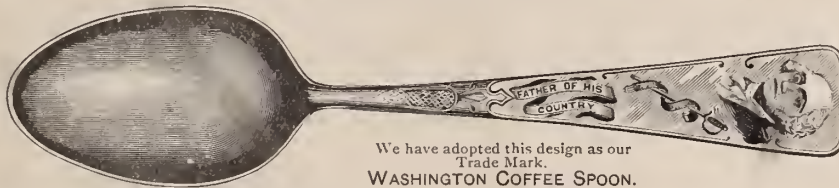

We have adopted this design as our Trade Mark.
WASHINGTON COFFEE SPOON.

WHY SHOULD YOU BUY THESE SPOONS?

First. Because they represent the three most noted men this country ever produced.

Second. Because the designs are patriotic in their nature, and everybody will want them for keepsakes.



We have adopted this design as our Trade Mark.
LINCOLN TEA SPOON.

Third. Because the craze for collecting Souvenir Spoons is contagious, and every lady in the land must have the disease. Our National spoons are the remedy.

Fourth. Because all foreigners visiting our country will buy these souvenirs of our noted men for their collection of keepsakes.



We have adopted this design as our Trade Mark.
GRANT ORANGE SPOON.

Fifth. Because when your customers buy, they will buy the trio instead of buying only one, as they do of other designs.

P. O. Drawer, No. 5224.

Very truly yours,

Sterling Silver Souvenir Co.,

SEND FOR ILLUSTRATED CIRCULAR AND PRICE LIST.

BOSTON, MASS.

Lancaster.

Among the traveling men in town last week were Mr. Hall, of the Wilcox Silver Plate Co., and Mr. Levy, of Adolphe Schwob, New York, and J. F. Smith, of Barbour Bros., Hartford, Conn.

The property of the Lancaster Watch Co., which the assignee, D. R. Patterson, tried to sell a week ago but got no bidders, was condemned by a sheriff's jury Friday afternoon. Sheriff Sides will sell the property some time between now and August.

W. W. Appel on Saturday opened his new jewelry store, at 170 N. Queen St. The store is equipped with a large stock, and is handsomely fitted up. The store is provided with the most attractive sign in town in the shape of a zinc revolving watch, eight feet in height.

Ernest Zahm has just completed a most elaborate piece of work, in the shape of a jewel of the Knights of Maccabees, a Canadian order. The top bar is made of four different colored golds—red, yellow, green and white—with the name N. S. Boynton, in raised green rustic letters. Pendant is the centre bar representing a double arrow, with platina tips, and resting on it is a shield, surrounded with a green gold wreath, and a raised monogram, K O. T. M., in three colored golds. Pendant from the bar is the main body of the mark, representing the earth surrounded by a green gold wreath and a twist wire of platina and gold.

Raised upon the globe is a tent, a hand, a book and the sun, in proper colors and enamel, and swinging in the centre of the tent is a diamond of about one karat. Above the tent are six stars in diamonds. The base on which the globe rests is in shield form, made in four colored golds and enamel.

Pittsburgh.

H. J. Ladson, 457 Fifth Ave., died recently.

J. O. Slemmons has moved from 77 5th Ave. to 49 6th St.

William Hunt, Uniontown, this State, spent a few days in the city last week.

With the removal of M. G. Cohen from 533 Smithfield St., his big pavement clock has disappeared also.

The plate glass window of the store of M. J. Smith, 311 Smithfield Ave., was last Monday broken and goods valued at \$50 were robbed.

Mrs. E. P. Roberts & Sons announce a formal opening of their new art annex during the first week in May. The apartment is a most dainty one, in blue and gold.

Peter Gillen was sent to the workhouse last week for thirty days by Mayor Wyman. He was standing in front of Heinmans' jewelry store on Ohio St., with a big club in his hand. He turned suddenly and smashed the plate glass window.

TO THE TRADE. FINE WATCH REPAIRING

BY
JOHN C. SIMMONDS,
18 JOHN STREET, NEW YORK.
New pieces, such as Chronometer Locking Springs, Balance
tuffs, &c., made in the best styles. Watches sprung and
adjusted to temperature and longitude.

NICHOLSON FILE COMPANY,
Offices at Providence, R. I.

FILES—Extra TRADE
X F
MARK. **Fine—RASPS**

Works at Providence, R. I. } —FOR— } Works at
Pawtucket, R. I. } **JEWELERS,** }

WATCHMAKERS TOOLMAKERS, Etc.

A. PINOVER & Co.,

IMPORTERS OF

DIAMONDS



AND

Manufacturing Jewelers,
25-29 ANN STREET,
Cor. Nassau Street, **NEW YORK.**

Novelties in Diamond Mountings.

NOTICE TO THE TRADE.

By numerous Letters Patent of the United States, the undersigned control all practical methods of making Screw Cases. This notice is rendered necessary for the protection of the trade and the public at this time, by reason of the recent bringing out of a filled case, which is a flagrant infringement on our patents. Suit will be promptly instituted against the manufacturers of the infringing cases, and the trade is warned that all dealers who may be found to have such cases in their possession, or to have sold the same, will be held to a strict account.

ROBBINS & APPLETON,

JOSEPH FAHYS & Co.,

KEYSTONE WATCH CASE COMPANY.

FASHIONS IN JEWELRY

A Lady's Ramble Among the Jewelers.

Some of the newest claret jugs are reproductions of old Flemish bottles.

The fleur-de-lis is a graceful and favorite design in brooches and in chatelaines.

Ball-shaped watches suspended from a chatelaine chain are liked by many.

Among the costly ornaments, rank diamond chatelaines and pendant watches.

The tendency at present is to display as much jewelry as possible on all occasions.

Pierced work is fashionable now in silver table ware, especially in bowls and odd dishes.

The birthday ring for April has the diamond for its gem, which is the emblem of innocence.

Umbrellas and parasols designed to carry with mourning costumes, have ebonized or onyx handles,

A unique bracelet is the one of woven chain showing strands of silver, different golds and platinum.

Coalport china cups and saucers find many admirers, especially when these rest in a framework of silver.

No two watches are alike, and an odd one seen had a chocolate-colored dial with the hands and numerals in blue.

A bride's jewel-case is not complete, when it does not include a diamond bracelet, earrings, finger ring and brooch.

The newest flower vases, both in silver and glass, take the form of a champagne glass, a thistle or a water lily.

An entirely new style in ice cream dishes is one of a long, narrow, flat shape, with gilt centre and richly-chased border.

It is the correct thing now, to add a souvenir spoon to the conventional christening present of pap-bowl and mug.

Stocking suspenders of gay-colored silk elastic ribbon, with silver trimmings, rival in popularity the silver-clasped garters.

The new chatelaine watch chains are made in two styles, with pins and hooks. Some women prefer one and some the other.

It is told that Mrs. Henry M. Stanley, during her visit here, has been the recipient of an interesting collection of souvenir spoons.

To meet the demand for many gems in the way of finger rings, is a ring bearing two diamond clusters. These are placed on the over-lapping ends of the shank, and present the effect of two cluster rings when on the finger.

ELSIE BEE.

BIRTHDAY RINGS!

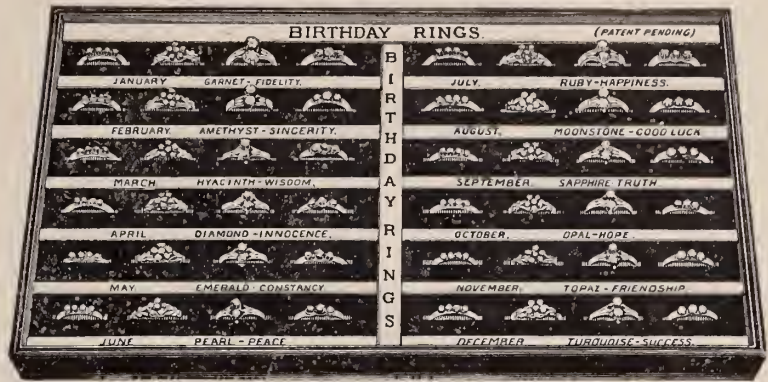

In order to meet the increasing demand for BIRTHDAY RINGS, we have originated and Patented an attractive novelty in the shape of elegant trays, containing of assorted patterns, 12, 24 or 48 Rings, one, two or four for each month, with appropriate stones and the sentiments thereof, printed upon the trays in gilt letters.

As the whole cost is but a very moderate amount, while we make no charge for the trays, which are of velvet and satin, as handsome as can be made, and the Rings they contain are of our latest and most desirable styles, we think that every Retailer will find it for both his interest and convenience to order one of these trays from us.

M. B. BRYANT & CO.,

* * RING MAKERS, * *

10 MAIDEN LANE,

NEW YORK.

THE "BRYANT" INITIAL RING, easily interchangeable, still keeps the lead as the best made - SIMPLE, STRONG and HANDSOME - in trays of 6 or 12, with separate initials.

F. F. IDE MANUFACTURING CO., PEORIA, ILLINOIS,

Manufacturers of

WATCH TOOLS.

Contracts Taken for Manufacturing PATENT ARTICLES in QUANTITIES.

WATCH WORK FOR THE TRADE A SPECIALTY.

IDE'S UNIVERSAL MAIN-SPRING WINDER. PRICE, \$1.75.



KEY-WINDING WATCHES MADE STEM-WINDERS.

Over forty thousand American Watches (men's sizes) have been altered to stem-winders by means of ABBOTT'S PATENT STEM-WINDING ATTACHMENTS.

HENRY ABBOTT, MANUFACTURER, 4 MAIDEN LANE, NEW YORK.

Remove May 1st to No. 14 Maiden Lane.

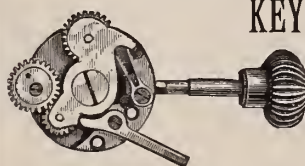

"BUNYANKA"

The best seamless wire, gold soldered chain in the market. Only slight advance over plated prices. Warranted for ten years.

E. H. SAXTON & CO.,

SEND FOR SAMPLE DOZEN.

58 Winter Street, Boston, Mass.



ROGERS & BRO. A-1.



OLDEST BRAND AND HIGHEST GRADE OF ELECTRO SILVER PLATE.

ROGERS & BROTHER, Manufacturers,

16 Cortlandt Street, New York.

Waterbury, Conn.

HOLLOW WRAE.

Price Lists upon Application accompanied by Business Card.

WATERBURY CLOCK CO., CLOCK MANUFACTURERS.

SALESROOMS:

10 Cortlandt St., New York,

GEO. M. VAN DEVENTER AGENT.

SALESROOMS:

114 & 116 Wabash Avenue,
CHICAGO,

CHARLES J. DODGSHUN, Agent.

SALESROOMS:

528 & 530 Market Street,
SAN FRANCISCO.

A. I. HALL & SON, AGENTS.

FACTORIES:

Waterbury, Conn.

123 Stockwell Street, Glasgow,

T. R. DENNISON, AGENT.

"LIBERTY" SOUVENIR SPOON.

THIS unique design represents the old Liberty bell in Independence Hall, Philadelphia, which was rung at the signing of the Declaration of Independence, July 4th, 1776.

IT IS ADAPTED FOR SALE ANYWHERE.

Made in Orange, Tea and Coffee Sizes.

This design is controlled and for sale only by

SIMONS BRO. & CO., 618 Chestnut St., Phila., Pa.

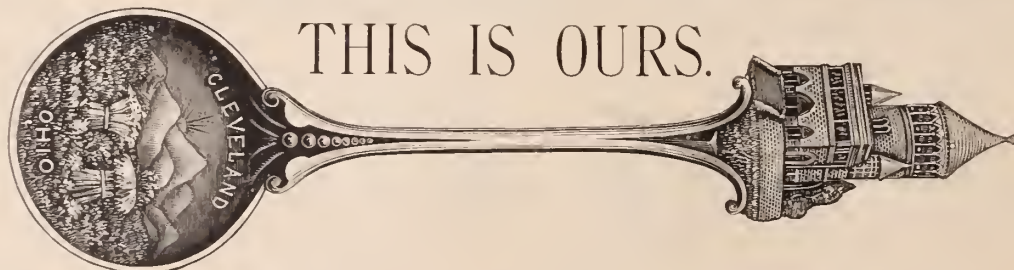
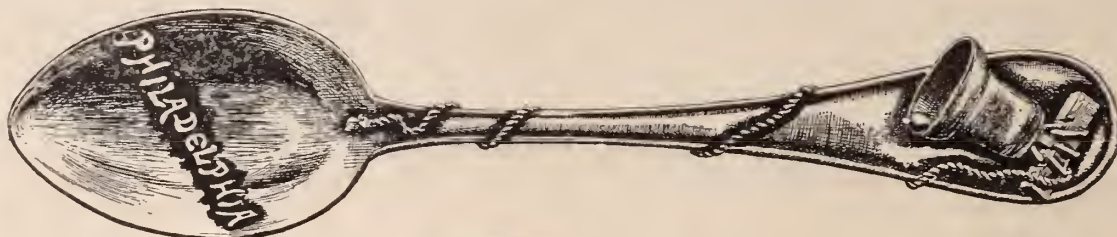

THIS IS OURS.

THE GARFIELD MEMORIAL SPOON.

For particulars, address THE COWELL & HUBBARD CO.,

177 & 179 Superior St., Cleveland, Ohio.

Recent Patents

Issue of April 21, 1891.

DESIGN PATENT **20,682**. SPOON. ROLLA W. HESS, St. Louis, Mo.—Application filed March 14, 1891. Serial No. 385,131. Term of patent 7 years.

DESIGN PATENT **20,683**. SPOON. ROLLA W. HESS. St. Louis, Mo.—Application filed March 14, 1891. Serial No. 385,132. Term of patent 3½ years.

DESIGN PATENTS **20,685** and **20,686**. SPOON. WILLIAM B. DURGIN, Concord, N. H.—Applications filed March 30, 1891. Serial Nos. 387,028 and 387,029. Terms of patents 7 years.

DESIGN PATENT **20,687**. SPOON, ETC. EMMA V. HALLETT, Hartford, Conn.—Application filed March 18, 1891. Serial No. 385,551. Term of patent 3½ years.

450,617. WORKMAN'S TIME-RECORDER. JOHN C. ENGLISH, New York, N. Y., assignor of one-half to Robert L. Burnett, Plainfield, N. J.—Filed Nov. 1, 1890. Serial No. 370,043. (No model.)

450,956. BURGLAR-PROOF SAFE. PETER WILHELM, Portland, Ore.—Filed Aug. 28, 1890. Serial No. 363,355. (No model.)

As an improvement in safes, the combination, with the frame, of a dry non-combustible lubricous filling therein, a net-work of loose rods embedded in the filling at right angles to the face of the frame and having their outer ends tapered.

450,618. METHOD OF PREPARING GEM-SETTINGS. ARTHUR HOGG, Buffalo, N. Y.—Filed Oct. 15, 1890. Serial No. 368,163. (No model.)

This method of preparing gem-settings, consists in first punching a blank with the required fingers, then

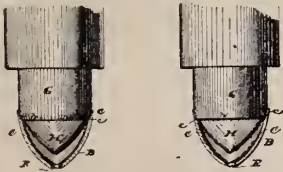

drawing this blank into a cup shape, then inserting a stem into this cup, and finally milling the fingers on their inner side with a milling-tool, to form the shoulder for the gem.

450,638. WATCH-CASE SPRING. JAMES E. SEARING, Mount Vernon, N. Y.—Filed Dec. 10, 1890. Serial No. 374,226. (No model.)

The combination of the curved body portion having the seat *e*, shoulder *e'*, and recesses or depression *e''*



with the elastic or springy portion provided with the squared shoulder *d'* and the turned-down ear *d''*, and with the screw *f*.

450,842. WATCH-PROTECTOR. ALBERT EP- PLE, Providence, R. I.—Filed Feb. 14, 1891. Serial No. 381,500. (No model.)

This improved protector consists of a rod having a spirally-bent wire hook at one end, and rotatably



mounted in a case having an end with a slot, through which the spiral hook is capable of being extended

from the case or withdrawn into the case by the rotation of the rod.

450,966. ELECTRO-MAGNETIC APPARATUS FOR OPERATING STOP-WATCHES. FRANK A. MATTHEWS, Providence, R. I.—Filed Feb. 7, 1891. Serial No. 380,644. (No model.)

The combination of the electro-magnets and armatures and means of operating the same by electricity,

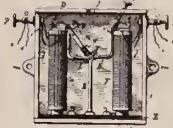

the lever K, the rock-shaft L, standards HH', the stop-watch having the rod *b*, the case having a top plate, and the pusher S, extending through the top plate and abutting against the rod.

450,637. WATCH-CASE. JAMES E. SEARING, Mount Vernon, N. Y.—Filed Dec. 4, 1890. Serial No. 373,583. (No model.)

The combination of a main shell constituting the back

lid and centre portion, the blind centre hinged thereto, the case-springs formed of flat sheet metal, and the

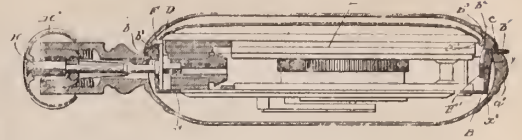

screws passed radially through the blind center for securing the case-springs.

THE **RYDER & DEARTH** DESIGNERS & ENGRAVERS

Fine Commercial and Copper-Plate Printers.

A Specialty of

Jewelers' Printing, Cuts and Electrotypes.

Headquarters for JEWELERS' CARDS.

BEST WORK.

PROMPT DELIVERY.

LOW PRICES.

No Order Too Large! None Too Small!

146 Westminster Street,

PROVIDENCE.

RHODE ISLAND.

HILDRETH MANUFACTURING COMPANY,

53 MAIDEN LANE, NEW YORK.

MANUFACTURERS OF PLAIN SOLID GOLD RINGS.

SEND FOR PRICE LIST.

C. F. HAPPEL & Co.,

* WHOLESALE *

JEWELERS

86 & 88 State Street,
CHICAGO, ILL.

ALBERT S. GAGE.

H. A. WHEELER.

CHARLES C. HILTON.



The *Wellington*

OPENED SEPT., 1890,

As the Best Located, Furnished, Lighted,

Ventilated and Equipped EUROPEAN

HOTEL in the Country.

Provided with large Fire and Burglar-Proof Vault for Valuables. Steam and Electric Lighted throughout. Rates from \$1.50 to \$3.00 per day for rooms. Suites with baths from \$3.50 upwards. CUISINE UNEQUALLED.

GAGE HOTEL COMPANY, Proprietors,
Wabash Ave. and Jackson St.,
CHICAGO, ILL.

The Other Side of Life.

HIS BILL OF EXPENSES.

PRINCIPAL—What is this item in your expenses for one microscope?

SALESMAN—That was to see my hopes of selling Blank, Dash & Co., at Kokomo.

PRINCIPAL—And this coffin?

SALESMAN—For the hopes when they were dead.

THE UNKNOWN THIRTIETH BIRTHDAY.

CHOLLY CHOLMONDELEY—There is Alice Scott, Gwendolin Fassett, Minnie Ponsoy, all wear birthday rings; but Katherine Withers can't abide them.

HAROLD HARRINGTON—I suppose she told everyone, some time ago, she had reached her twenty-ninth birthday.

AMBIGUOUS.

MISS PASSEE—I hardly know how it is, but I must follow the fads. Now, everyone is wearing birthday rings and—

SILLYBOY—And are you wearing them too?

MISS PASSEE—Yes, I have bought one for each year.

SILLYBOY—You could almost open a jewelry store, couldn't you?

WOULD HAVE IT AFTER A WHILE.

STRANGER (In the police court)—Have you got the time?

GILIGAN—Not yit, but Oi guess Oi'll git six months.

Spectacles and opera glasses are in no way related, except in the theatrical line.

"An eye for an eye" quoted the patient who was having a glass eye substituted for a blind one.

BOWLES—I must introduce you to Pearl Jingleby; you'll find her charming.

KNOWLES—I know her mother. I don't like mother of Pearl.

HE WAS OUT OF ORDER.

TEACHER—Keep your hand down, John Billings; when I am ready, I will call upon you.

(Ten minutes later.)

Now John Billings, I will hear what you have to say.

JOHN BILLINGS—I only wanted ter tell yer that I seed a tramp in der hallway hook yer gold headed umbrella.



CHARLES and ANGELINA are to meet at the door of Spar, the Jeweler, at seven, precisely.

Angelina: { "Was there } Man
Charles: { ever a } Woman
who knew the worth of time?

Next morning.—CHARLES and ANGELINA return a few letters.

Life's Calendar for April.

RECRUITING PHYSICIAN—What reason can you give for not enlisting?

PEASANT—My eyesight is bad.

RECRUITING PHYSICIAN—How do you know it is bad?

PEASANT—Do you see that nail up there, Doctor?

RECRUITING PHYSICIAN—Yes.

PEASANT—Well, I don't.

Journal Pour Rire.

WE ARE HEADQUARTERS



For ANYTHING and EVERYTHING in the OPTICAL LINE, and with our large factories, equipped with the most improved machinery, and 500 skilled workmen, we are producing goods which competitors cannot reach either in PRICE or QUALITY. See our samples and learn our prices before buying your stock. 400 styles of Spectacles and Eye Glasses, from the cheapest to the best. So we are sure to suit you.

HEADQUARTERS FOR OPERA GLASSES.

"Audemair" Opera, Field and Marine Glasses are increasing in popularity; the carefully finished achromatic lenses, good workmanship and beauty, have won for them a reputation and created a demand which exceeds our most sanguine expectations. We now carry a larger stock and more varieties than any house in the country. Customers are already sending in their orders and having their names engraved on eye-piece.

HEADQUARTERS FOR OPERA GLASS HOLDERS.

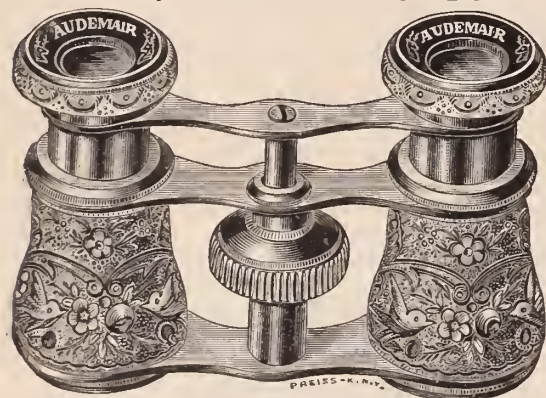

The Spencer Opera Glass Holder has proved a great success. The positiveness and simplicity of the clamping device is appreciated wherever shown. The trade are sending in their holders of other makes and having them exchanged for ours. Great variety of designs and new ones in preparation.

SEND FOR CATALOGUE AND PRICES OF ANYTHING YOU NEED IN THE OPTICAL LINE.

The Spencer Optical Mfg. Co., Manufacturing Opticians,
15 MAIDEN LANE, NEW YORK.

READ VISUAL DEFECTS AND THEIR CORRECTION, BY DR. STOUT.



BIPPART & CO.,

NEWARK, N. J.

MANUFACTURERS OF

FINE JEWELRY,

BROOCH PINS, SCARF PINS, EARRINGS, LINK BRACELETS,
WIRE BRACELETS, HAT PINS and RINGS,



Enameled, Roman or Polished Gold, 14-K.



14-K. • ENAMELED • WORK • A • SPECIALTY.



RAH! RAH!! RAH!!!
THE RECORD BROKEN.

More Lathes sold in March than in any previous month.

- 1 No. 1 WHITCOMB.
- 30 No. 1½ WHITCOMB.
- 51 No. 1½ WEBSTER-WHITCOMB.
- 1 No. 2 WHITCOMB.

83 IN ALL.

AMERICAN WATCH TOOL CO.,

Stony Batter Works. WALTHAM, MASS.

A. WITTNAUER,

30 Maiden Lane, New York,

MAKER OF

COMPLICATED * WATCHES.

TIMING WATCHES

OF ALL STYLES.



SPLIT SECONDS

AND

Minute Repeaters.

VARIOUS GRADES, ALL ACCURATELY MADE.

Also Sole Agent for the Celebrated LONGINES & AGASSIZ Watches.

Etching on Glass and Metals.

GLASS is etched by means of hydrofluoric acid gas or liquid hydrofluoric acid, that is, a solution of the gas in water. The former in contact with glass produces a rough surface, as that of ground glass, while the latter ordinarily leaves the surface clear. The gas is prepared by mixing together finely powdered fluor spar, calcium fluoride 3 parts and strong sulphuric acid 2 parts, in a leaden dish and applying a very gentle heat.

The plates to be etched may be placed over the dish. The operation should be conducted under a hood or in the open air, to avoid inhaling the pernicious fumes. The plates are prepared by coating them while warm with wax or paraffine, through which the design is with a suitable graver cut to the surface of the glass. In preparing the liquid acid, the mixture of the spar and oil of vitriol is placed in a leaden or platinum retort which is heated, and the gas given off is conducted into a leaden bottle partly filled with water, which absorbs it. In contact with the flesh the acid produces stubborn sores. Metals are usually etched with dilute nitric acid, or nitric and sulphuric acid, or sulphate of copper and salt, or hydrochloric acid and chlorate of potash.

A silversmith of the noble Faubourg Paris, recently discovered at Versailles (in an old curiosity shop, no doubt) a stamper with the arms of Louis XVI., which he believes belonged to the *maison royale*.

A GREAT CONVENIENCE FOR



Clock Dealers and Repairers.



We have now a complete stock of Wheels, Pinions, Hands, Dials and all loose pieces for French and English movements. Also single movements with or without dials.

Our stock of imported clocks comprises Chiming and Hall Clocks, Sèvres and Faience, Vernis Martin, Gilt Bronze, Crystal with Mercurial Pendulum, Carriage Clocks in endless variety of styles and combinations, Marble and Onyx Clocks of the best selling designs, Coaching and Desk Watches, Regulators, etc.

NEW GOODS ARRIVING EVERY WEEK.

Apply for our Catalogue, or inspect our stock to compare our prices.

CHARLES JACQUES & CO.,

2 MAIDEN LANE, NEW YORK.

THE UNIVERSAL MAINSPRING,

FOR AMERICAN WATCHES.

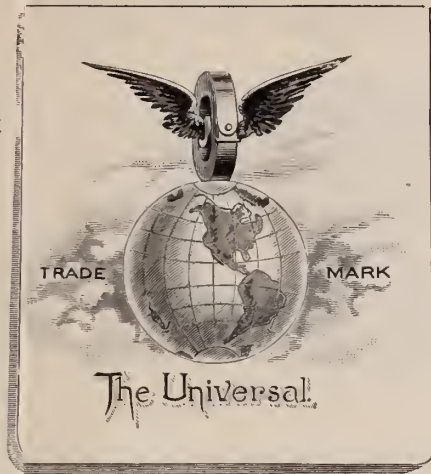

UNIFORM
IN
COLOR.

EXACT
IN
SIZE.

See that each spring bears the name of "Universal." All others are imitations.

The Acme of Perfection in a Mainspring and the BEST QUALITY
of the BEST manufacturer in Europe.

DON'T use two dozen cheap springs for six
watches while we GUARANTEE that you
can rely on ELEVEN "UNIVERSALS"
in every DOZEN.

Save Time, Money and Reputation

By Doing GOOD WORK with GOOD MATERIAL.

Price: \$1.50 per Dozen; \$15.00 per gross.

Packed in anti-rust tin boxes ESPECIALLY MADE FOR THIS SPRING.

For Sale by all Jobbers. Imported by

HAMMEL, RIGLANDER & Co.,

35 MAIDEN LANE, NEW YORK.

If you cannot obtain the UNIVERSAL from your Jobber, notify the
Importers and they will supply you with a list of Jobbers who do keep it.

A. N. CLARK, PLAINVILLE, } MANUFACTURER of the Celebrated
CONN. }

LOOP WATCH KEY.



The best for the price in the World. Size
of Square stamped on each Key.

Also Key Rings, Watch Case Springs,
Jewelry Tools, Tweezers, Etc.

SEND FOR PRICE LIST. * SOLD BY ALL JOBBERS IN THE LINE
AT MANUFACTURER'S PRICES.

YOUR TOTAL SALES AND EXPENDITURE

By the Day, Week and Month, shown at a
glance by the "Complete Business Register,"
the best arranged book for keeping a record of
the condition of one's business. Send for free
sample sheet, prices, etc. Address,

H. W. PAMPHILON,

30 Bond Street, New York

TO THE TRADE ONLY.

Balance Staffs, - 60 Cents.

Inserting Pivots, 40 Cents.

ALL OTHER WORK IN PROPORTION.

SEND FOR PRICE LIST.

THOMAS JUZEK & CO.,

ELGIN, ILL.

MAXHEIMER & BERESFORD,

MANUFACTURERS OF

FINE DIAMOND JEWELRY,

No. 3 Maiden Lane, New York.

ORDER WORK A SPECIALTY.

REMOVED TO

189 BROADWAY.

R. A. Kipling

Importer of Precious Stones

31, Union Square
New-York

19, Rue Drouot
Paris

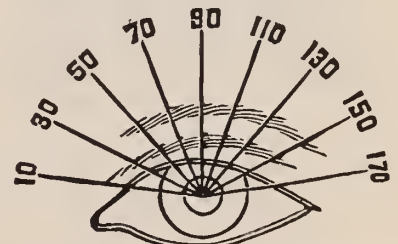

SEND TO

GENEVA OPTICAL CO.

23 Washington St., Chicago.

FOR PRESCRIPTIONS, REPAIR AND ORDER WORK
PROMPTLY AT LOWEST PRICES.

INSTRUCTION

IN

HOROLOGY, Etc.

Best Facilities in the Land.

WALTHAM SCHOOL OF HOROLOGY

D. D. PALMER, Proprietor,

Correspondence Solicited.

WALTHAM, MASS.

ROY



B. & W. B. SMITH,

220 West 29th Street, New York City.

L. & M. KAHN & CO., Importers of DIAMONDS, 10 Maiden Lane, N. Y.

COMPARISON - ALL OTHER GOLD FILLED CASES WITH THE CELEBRATED CROWN LION EXHIBITOR H. MURRIS SONS HAND ENGRAVED CASES

Cases with Moulding,
1-16th Inch Diameter.

Cases of Plate Glass and
no Moulding at all.

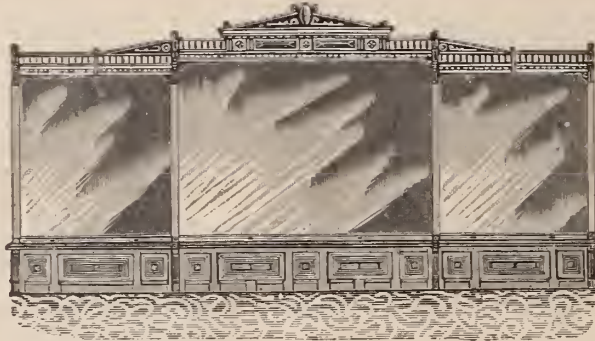

WALL CASES—PERPENDICULAR SLIDING DUST-TIGHT SASH. Shelved Complete.

Call and see our wonderful
novelties.
They can be seen nowhere else.

Show-room open for inspection,
8 A. M. to 5 P. M.,
every day.



COUNTER CASE, WITH OUR PATENT DUST-TIGHT PERPENDICULAR SLIDING DOORS.

Correspondence solicited. Call and
see us, even if you do
not wish to buy.

Catalogue Illustrations Issued. * We make to Order only.



S. P. HOWARD,
Gold and Silver Assayer,
Refiner and Sweep Smelter,
8 & 10 JOHN STREET, NEW YORK.
Smelting and Refining Works,
28, 30 & 32 Cumberland St., Brooklyn, N. Y.
Specialties: Sweepings, Gold, Silver and Platinum.

DIAMONDS.

Wm. S. Hedges & Co.,
Importers of Diamonds

And Manufacturers of DIAMOND JEWELRY.
No. 170 BROADWAY,
S. E. Cor. Maiden Lane, } New York.
27 Holborn Viaduct, London.



IMPORTERS OF DIAMONDS,
PEABODY & CO.
182 BROADWAY, NEW YORK.

PLATINUM

SCRAPS MELTED.
BOUGHT AND SOLD.

ROBERTSON & LEBER,
Gold, Silver and Platinum Refiners,
13 & 15 FRANKLIN ST., NEWARK, N. J.

S. F. MYERS & CO., Wholesale Jewelers

EVERYTHING
THAT
PERTAINS
TO THE
JEWELRY TRADE.
22
DEPARTMENTS.



WE REQUIRE
AND OCCUPY THE
LARGEST
SALESROOMS
IN OUR LINE.
4 STORES.
GROUND FLOOR.

48 & 50 Maiden Lane and 33 & 35 Liberty Street, New York.
CONSULT OUR MAMMOTH CATALOGUES.

Gunzburger Bros., Importers of Diamonds, 35 Maiden Lane, N. Y.

